

YAMAHA

PARTS CATALOGUE

FZR1000T (2LL)

OCEANIA

72LL-700E2

CONTENTS

ENGINE

Cylinder Head	B2
Cylinder	B3
Crankshaft · Piston	B4
Valve	B5 ~ B6
Camshaft · Chain	B7
Water Pump	B8
Radiator · Hose	B9
Oil Pump	B11 ~ B12
Oil Cleaner	B13
Intake	B14 ~ B15
Caburetor	C2 ~ C3
Exhaust	C4
Crankcase	C5
Crankcase Cover 1	C7
Starter	C8
Clutch	C9
Transmission	C10 ~ C11
Shift Cam · Fork	C12
Shift Shaft	C13

CHASSIS

Frame	C14 ~ C15
Fender	D2 ~ D3
Side Cover	D4
Rear Arm	D6 ~ D7
Rear Suspension	D8

Steering	D9
Front Fork	D10 ~ D11
Fuel Tank	D12 ~ D13
Seat	D14
Front Wheel	D15
Front Brake Caliper	E2
Rear Wheel	E3 ~ E4
Rear Brake Caliper	E5
Steering Handle · Cable	E6
Front Master Cylinder	E7
Front Master Cylinder 2	E8
Stand · Footrest	E9 ~ E10
Rear Master Cylinder	E11
Cowling 1	E12 ~ E13
Cowling 2	E14 ~ E15
Generator	F2
Pick Up Coil · Govenor	F3
Starting Motor	F4
Flasher Light	F5
Meter	F6 ~ F7
Headlight	F8
Taillight	F9
Handle Switch · Lever	F10
Electrical 1	F11 ~ F12
Electrical 2	F13

TABLE OF COMPARISON

Table of Comparison	F14 ~ G3
---------------------------	----------

INDEX

NUMERICAL INDEX	M1 ~ M5
-----------------------	---------

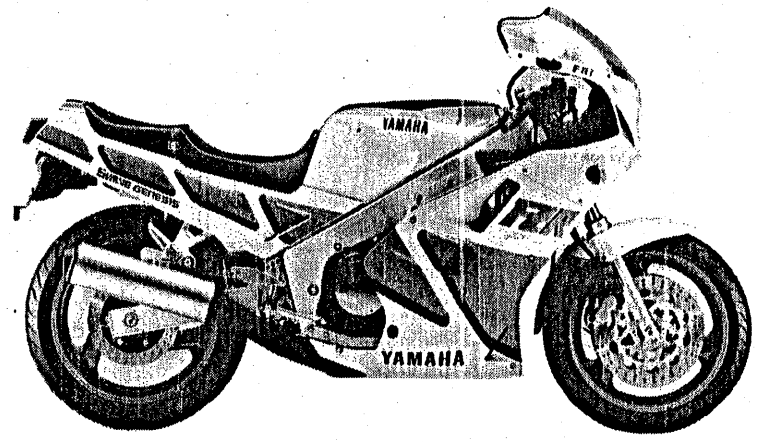

A3

FOREWORD

This Parts Catalogue is related to the parts in use for the Yamaha FZR1000T (2LL)

When you are ordering replacement parts for the FZR1000T (2LL), refer to this Parts Catalogue and quote both part numbers and part names correctly.

1. Modifications or additions which have been made after issue of the Parts Catalogue will be announced in the Yamaha Parts News.

It is advisable that according to the Yamaha Parts News you make necessary corrections to the Parts Catalogue on hand to keep it up-to-date.

2. Abbreviations

The following abbreviations are used in this Parts Catalogue.

- U.R. Use size (thickness) and/or number as required.
- U.N. Use as many as you need.
- A.P. Alternate Parts
- L.M. Local Made
- F# Frame No. (Applicable machine No.)

3. The parts marked with (*) in the parts number column of this Catalogue are not supplied with by Yamaha, those have to be found locally.

4. Parts, which are to be supplied in the form of assemblies, are listed with an indentation of one letter's space, and a dot (.) is put against the name of each part.

EXAMPLE CARBURETOR ASS'Y
 . JET, pilot
 . NOZZLE, main

5. Indication of No. of constituent parts for assembly

The numeral appearing to the right of each constituent part under the description indicates the quantity of such parts for each individual assembly unit.

EXAMPLE

Part No.	Description	Q'ty	Remarks
2F5-83310-60	FRONT FLASHER LIGHT ASS'Y	2	
115-83311-80	. BULB (6V-18W)	1	
1M1-83309-60	. REFLECTOR	1	

6. Initial Serial No. and Color Code

(A) Frame Serial No.	2LL-000101 and following
(B) Engine Serial No.	2LL-000101 and following

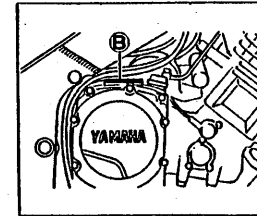
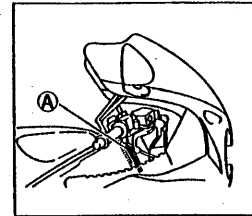

Color Code	Color Name	Abbreviate
GE/LN	SILKY WHITE/FINE RED	SW/FRD
GE/VA	SILKY WHITE/DYNASTY BLUE	SW/DYB
* JW	URUSHI BLACK	URB

7. Applicable colors of graphics are represented in the "Remarks" column by the letter(s) appropriately picked out of the full word(s) showing such colors.

EXAMPLE

Part No.	Description	Q'ty	Remarks
2N4-24110-00-X5	FUEL TANK COMP.	1	MAXIM RED
3J1-24240-10	. GRAPHIC, fuel tank set	1	for MXR

8. This Parts Catalogue contains modified specs as opposed to the preceding one. The modified items are asterisked (*) before their respective Ref. Nos. For the convenience of reference, Table of Comparison between old and new is provided at the end of this catalogue.

FIG. 1 CYLINDER HEAD

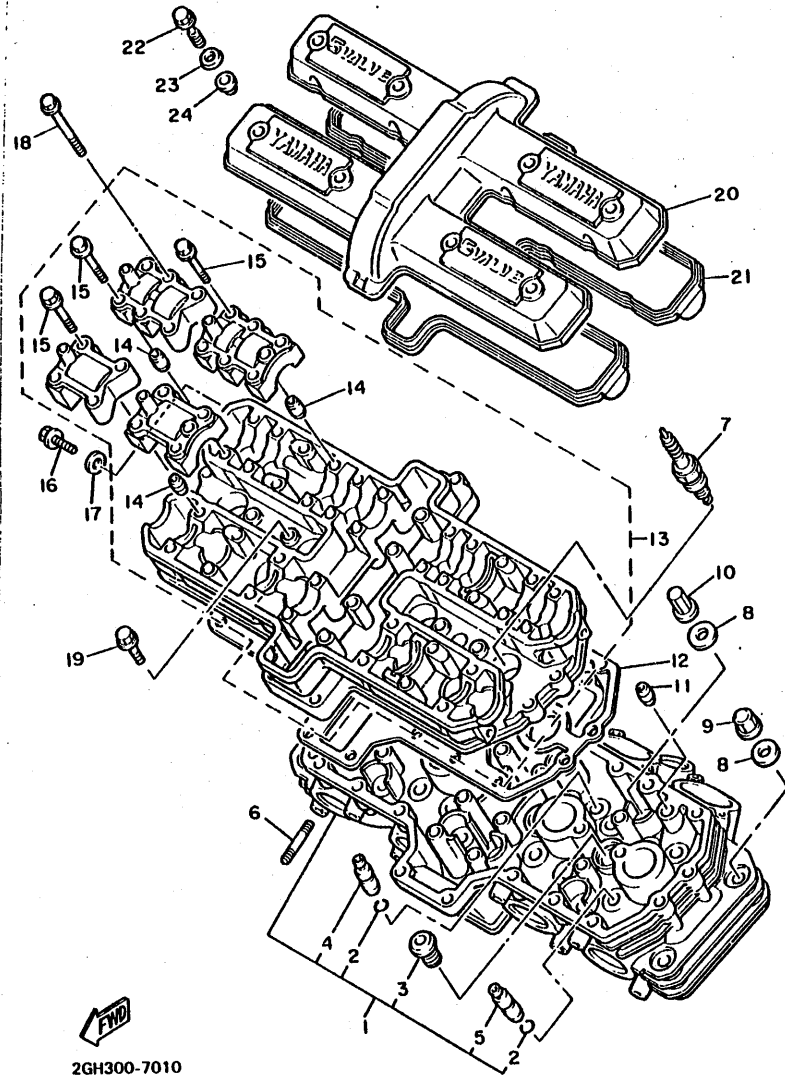

REF. NO.	PART NO.	DESCRIPTION	Q'TY	REMARKS
1	2GH-11101-00	CYLINDER HEAD ASSY	1	
2	93440-09141	.CIRCLIP	20	
3	90340-18101	.PLUG, straight screw	4	
4	1AA-11133-10	.GUIDE, intake valve	12	
5	1AA-11134-10	.GUIDE, exhaust valve	8	
6	90116-08504	BOLT, stud	8	
7	94701-00203	PLUG, sPark (NGK DR8ES-L)	4	UR
	94701-00222	PLUG, sPark (ND X24ESR-U)	4	UR
8	90201-096J9	WASHER, Plate	12	
9	90179-09489	NUT	4	
10	90179-09490	NUT	8	
11	99530-10014	PIN, dowel	2	
12	2GH-11182-00	GASKET, cylinder head 2	1	
13	2GH-1115A-00	CAM CASE ASSY	1	
14	99510-08016	.PIN, dowel	16	
15	90105-06153	.BOLT, washer based	16	
16	95026-06012	BOLT, flange	1	
17	90430-06014	GASKET	1	
18	90105-06362	BOLT, washer based	24	
19	95026-06025	BOLT, flange	11	
20	1TV-11191-00	COVER, cylinder head 1	1	
21	1AA-11193-00	GASKET, head cover 1	1	
22	90109-06746	BOLT	8	
23	90209-11262	WASHER	8	
24	2GH-1111G-00	RUBBER, mount 1	8	

YMA
2GH300-7010

FIG. 2 CYLINDER

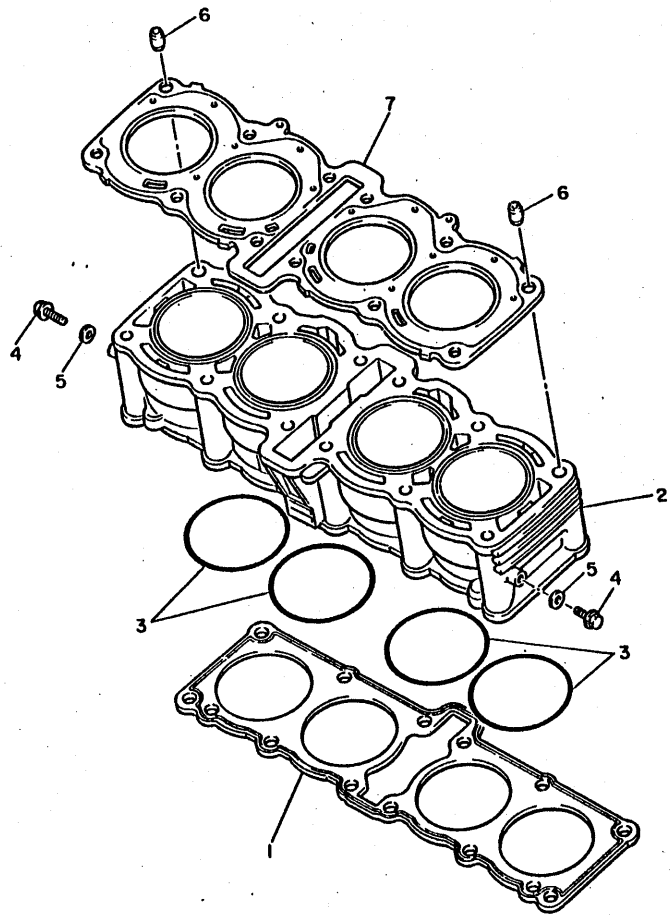

REF. NO.	PART NO.	DESCRIPTION	Q'TY	REMARKS
1	2GH-11351-00	GASKET, cylinder	1	
2	2GH-11310-00	CYLINDER	1	
3	93210-77363	O-RING	4	
4	95026-06012	BOLT, flange	2	
5	90430-06014	GASKET	2	
6	91810-08016	PIN, dowel	2	
7	2GH-11181-00	GASKET, cylinder head 1	1	

2GH300-7020

B3

FIG. 4 VALVE

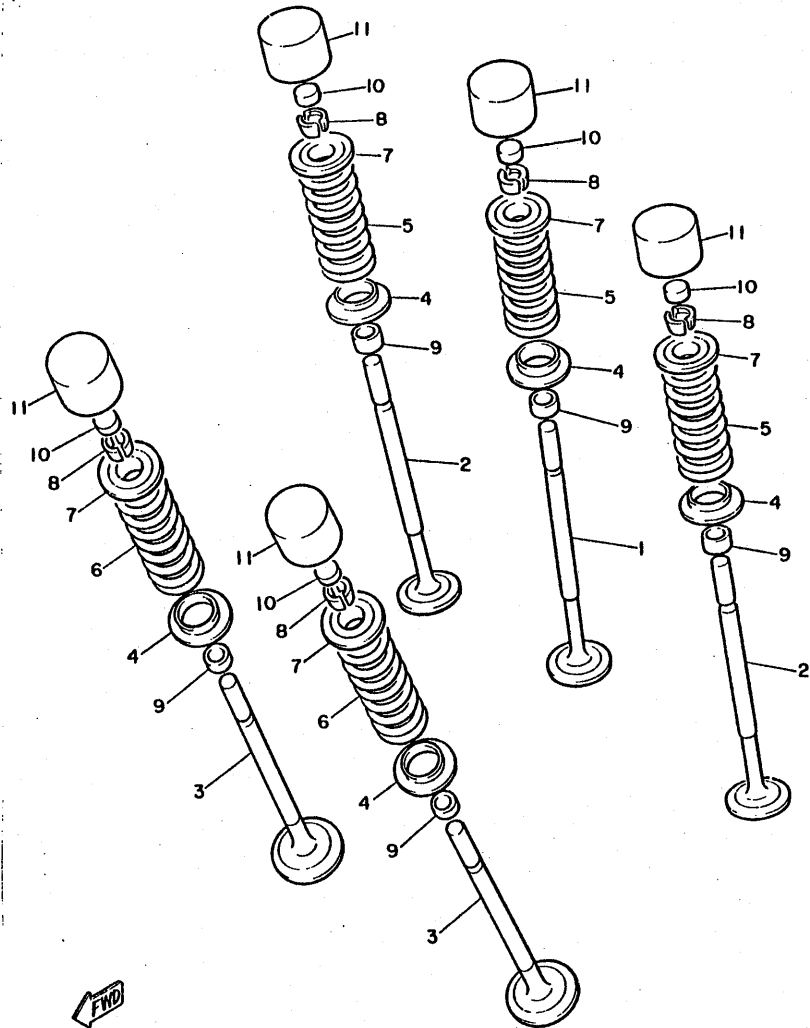

1FN310-5040

REF. NO.	PART NO.	DESCRIPTION	Q'TY	REMARKS
1	2GH-12111-00	VALVE, intake	4	
2	2GH-12112-00	VALVE, intake 2	8	
3	2GH-12121-00	VALVE, exhaust	8	
4	2GH-12116-00	SEAT, valve sPrin8	20	
5	1AA-12113-00	SPRING, valve inner	12	
6	1AA-12114-00	SPRING, valve outer	8	
7	1AA-12117-00	RETAINER, valve sPrin8	20	
8	1AA-12118-00	COTTER, valve	40	
9	33M-12119-00	SEAL, valve stem	20	
10	1AA-12168-00	PAD, adjusting (1.20)	20	UR
	1AA-12168-20	PAD, adjusting (1.25)	20	UR
	1AA-12168-40	PAD, adjusting (1.30)	20	UR
	1AA-12168-60	PAD, adjusting (1.35)	20	UR
	1AA-12168-80	PAD, adjusting (1.40)	20	UR
	1AA-12168-A0	PAD, adjusting (1.45)	20	UR
	1AA-12168-F0	PAD, adjusting (1.50)	20	UR
	1AA-12168-H0	PAD, adjusting (1.55)	20	UR
	1AA-12168-K0	PAD, adjusting (1.60)	20	UR
	1AA-12168-M0	PAD, adjusting (1.65)	20	UR
	1AA-12168-R0	PAD, adjusting (1.70)	20	UR
	1AA-12168-U0	PAD, adjusting (1.75)	20	UR
	1AA-12168-W0	PAD, adjusting (1.80)	20	UR
	1AA-12168-Y0	PAD, adjusting (1.85)	20	UR
	1AA-12169-10	PAD, adjusting (1.90)	20	UR
	1AA-12169-30	PAD, adjusting (1.95)	20	UR
	1AA-12169-50	PAD, adjusting (2.00)	20	UR
	1AA-12169-70	PAD, adjusting (2.05)	20	UR
	1AA-12169-90	PAD, adjusting (2.10)	20	UR

B5

FIG. 4 VALVE

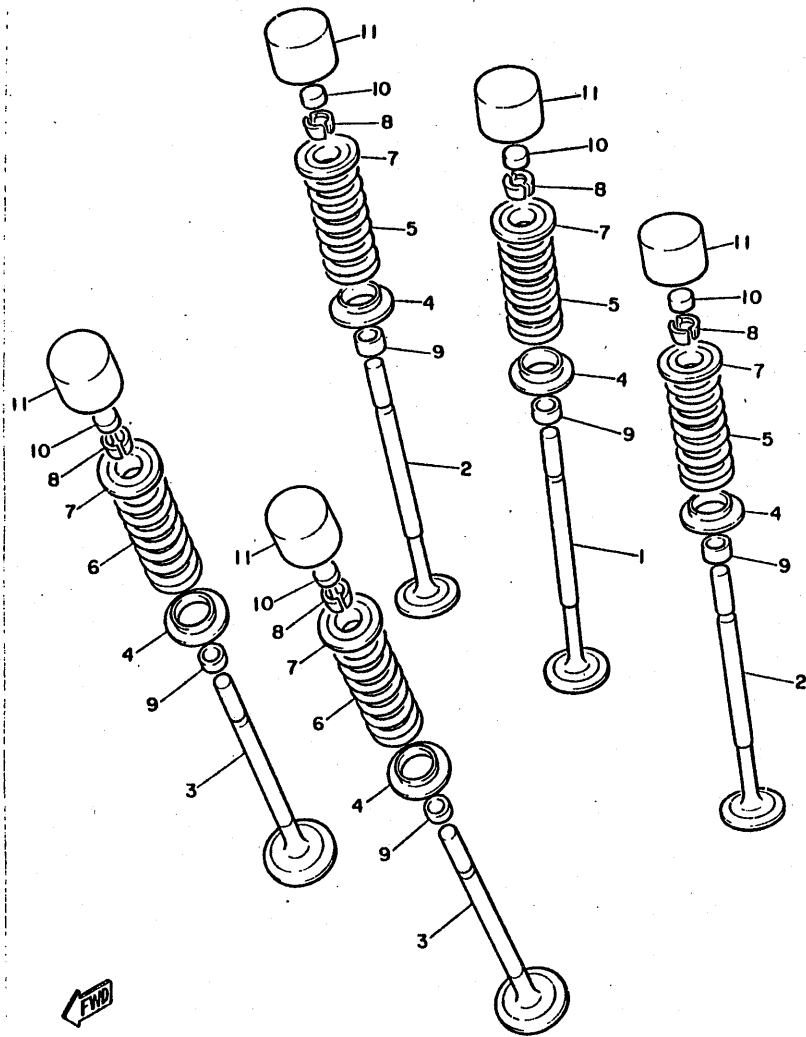

REF. NO.	PART NO.	DESCRIPTION	Q'TY	REMARKS
10	1AA-12169-E0	PAD, adjusting (2.15)	20	UR
	1AA-12169-G0	PAD, adjusting (2.20)	20	UR
	1AA-12169-J0	PAD, adjusting (2.25)	20	UR
	1AA-12169-L0	PAD, adjusting (2.30)	20	UR
	1AA-12169-N0	PAD, adjusting (2.35)	20	UR
	1AA-12169-T0	PAD, adjusting (2.40)	20	UR
11	2NK-12153-01	LIFTER, valve	20	UR black
	1AA-12153-09	LIFTER, valve(O/S)	20	UR Green



1FN310-5040

B6

FIG. 5 CAMSHAFT. CHAIN

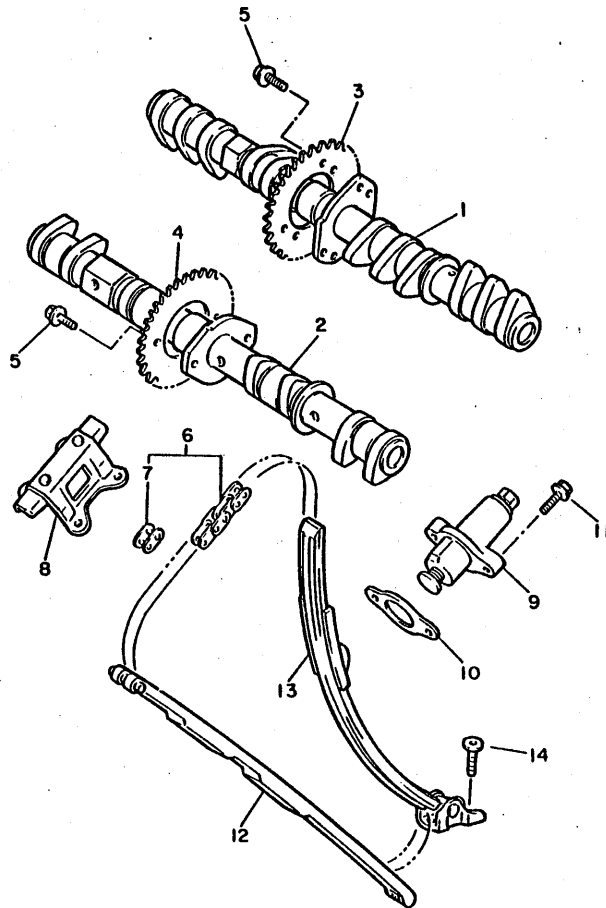

REF. NO.	PART NO.	DESCRIPTION	Q'TY	REMARKS
1	2GH-12171-00	CAMSHAFT 1	1	
2	1AE-12181-00	CAMSHAFT 2	1	
3	4G0-12176-01	SPROCKET, cam chain	1	
4	2GH-12176-00	SPROCKET, cam chain	1	
5	90105-07342	BOLT, washer based	4	
6	94581-01110	CHAIN (DID219FS-110L)	1	
7	94681-01021	.JOINT, chain	1	
8	2GH-12241-00	GUIDE, stopper 2	1	
9	1WG-12210-00	TENSIONER ASSY, cam chain	1	
10	30X-12213-00	GASKET, tensioner case	1	
11	95026-06025	BOLT, flange	2	
12	1AE-12251-00	DAMPER, chain 1	1	
13	2GH-12252-00	DAMPER, chain 2	1	
14	90109-065A8	BOLT	2	



2GH300-7050

B7

FIG. 6 WATER PUMP

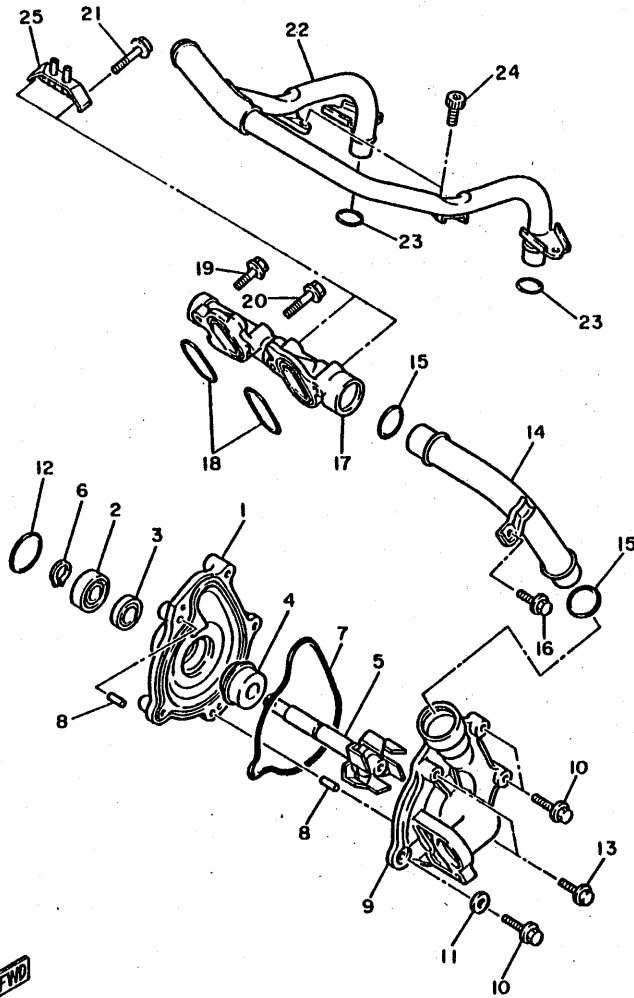

REF. NO.	PART NO.	DESCRIPTION	Q'TY	REMARKS
1	1UF-12421-01	HOUSING, water Pump	1	
2	93306-00106	BEARING	1	
3	93101-12060	OIL SEAL	1	
4	11H-12438-00	SEAL, mechanical	1	
5	1UF-12450-00	IMPELLER SHAFT ASSY	1	
6	99009-12400	CIRCLIP	1	
7	1AE-12439-00	O-RING	1	
8	93604-10011	PIN, dowel	2	
9	1AE-12422-01	COVER, housing	1	
10	95026-06025	BOLT, flange	3	
11	90430-06014	GASKET	1	
12	93210-33133	O-RING	1	
13	95026-06050	BOLT, flange	2	
14	1AE-12481-00	PIPE 1	1	
15	93210-23692	O-RING	2	
16	95026-06012	BOLT, flange	1	
17	1AE-12469-01	JOINT 1	1	
18	93210-30694	O-RING	2	
19	95026-06020	BOLT, flange	1	
20	95026-06030	BOLT, flange	1	
21	95026-06040	BOLT, flange	2	
22	2GH-12482-00	PIPE 2	1	
23	93210-18417	O-RING	2	
24	91316-06012	BOLT	2	
25	2GH-14413-00	STAY	1	



2GH300-7080

B8

FIG. 7 RADIATOR. HOSE

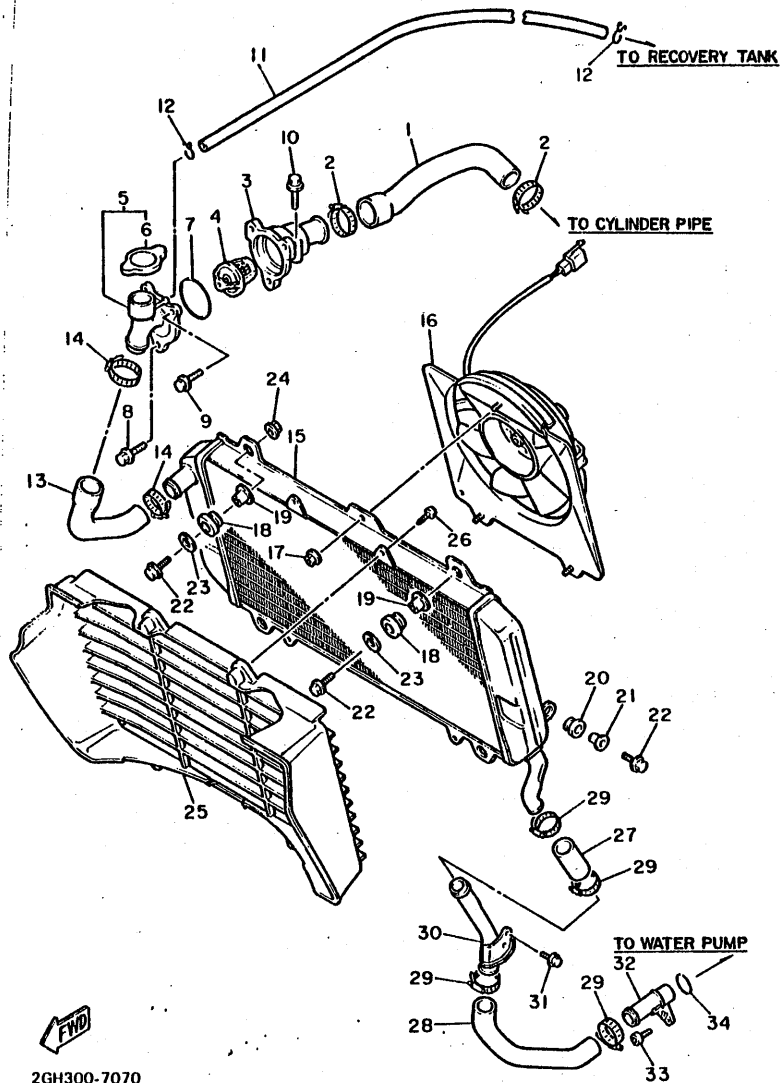

2GH300-7070

REF. NO.	PART NO.	DESCRIPTION	Q'TY	REMARKS
1	2GH-12576-00	HOSE 1	1	
2	90460-38241	CLAMP, hose	2	
* 3	IAE-12417-02	HOUSING, thermostat	1	
4	IAE-12410-00	THERMOSTAT ASSY	1	
5	IAE-12590-00	CONDUCTION ASSY	1	
6	IAE-12462-00	.CAP, radiator	1	
7	93210-49046	O-RING	1	
8	95023-06020	BOLT, flange	1	
9	95026-06020	BOLT, flange	2	
*10	95826-06030	BOLT, flange	1	
11	90445-096E8	HOSE	1	
12	90467-08003	CLIP	2	
13	2GH-12577-00	HOSE 2	1	
14	90460-38241	CLAMP, hose	2	
15	2GH-12461-00	RADIATOR ASSY	1	
16	2GH-12405-00	BLOWER ASSY	1	
17	95706-06500	NUT, flange	3	
18	90480-18276	GROMMET	2	
19	90387-07037	COLLAR	2	
20	90480-10297	GROMMET	2	
21	90387-06033	COLLAR	2	
22	95826-06020	BOLT, flange	4	
23	90201-062K2	WASHER, Plate	2	
24	95706-06500	NUT, flange	1	
25	2GH-12467-00	COVER, radiator	1	
26	97706-60114	SCREW, tapping	4	
27	2GH-12579-00	HOSE 4	1	
28	2GH-12578-00	HOSE 3	1	

B9

FIG. 7 RADIATOR. HOSE

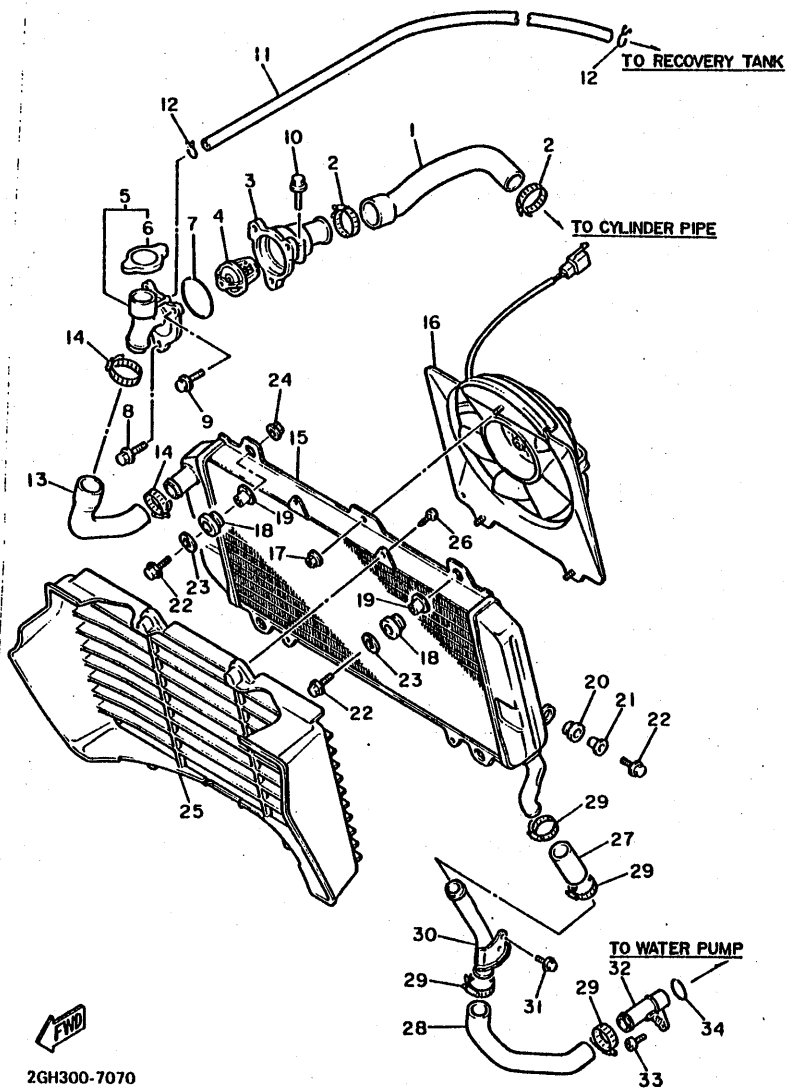

REF. NO.	PART NO.	DESCRIPTION	Q'TY	REMARKS
29	90460-38241	CLAMP, hose	4	
*30	2GH-12483-01	PIPE 3	1	
31	95021-06016	BOLT, flange	2	
32	2GH-12484-00	PIPE 4	1	
33	90110-06142	BOLT, hexagon socket head	1	
34	93210-23692	O-RING	1	



2GH300-7070

FIG. 8 OIL PUMP

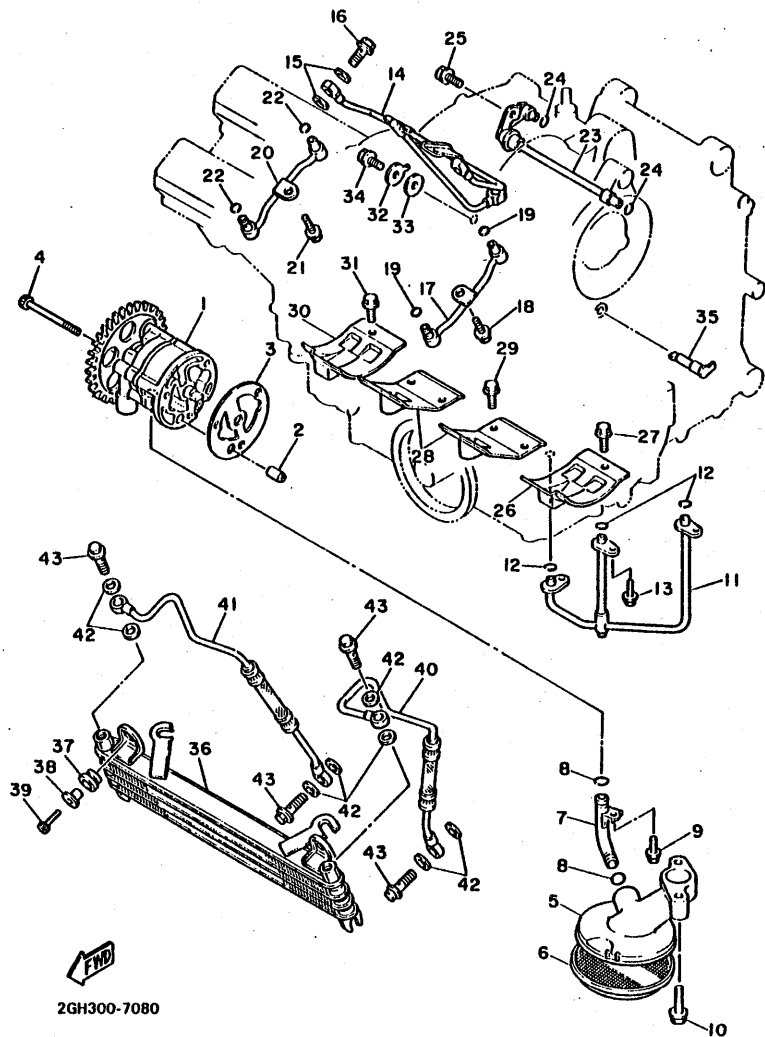

2GH300-7080

REF. NO.	PART NO.	DESCRIPTION	Q'TY	REMARKS
1	2GH-13300-00	OIL PUMP ASSY	1	
2	91810-18013	PIN, dowel	1	
3	2GH-13329-00	GASKET, Pump cover	1	
4	91316-06080	BOLT.	1	
5	2GH-13412-00	HOUSING, strainer	1	
6	2GH-13411-00	STRAINER, oil	1	
7	2GH-13431-00	PIPE, oil drain 1	1	
8	93210-11765	O-RING.	2	
9	95026-06010	BOLT, flange	1	
10	95026-06030	BOLT, flange	2	
11	1AE-13161-00	PIPE, delivery 1	1	
12	93210-06714	O-RING	3	
13	95026-06012	BOLT, flange	2	
14	1AE-13171-01	PIPE, delivery 2	1	
15	90430-10188	GASKET	6	
16	90401-10096	BOLT, union	3	
17	2GH-13181-00	PIPE, delivery 3	1	
18	95026-06012	BOLT, flange	1	
19	93210-06632	O-RING	2	
20	2GH-13191-00	PIPE, delivery 4	1	
21	95026-06012	BOLT, flange	1	
22	93210-06632	O-RING	2	
23	2GH-1316E-00	PIPE, delivery 5	1	
24	93210-07135	O-RING	2	
25	95026-06012	BOLT, flange	1	
26	2GH-15123-00	PLATE, baffle 1	1	
27	95026-06012	BOLT, flange	2	
28	1AE-15124-00	PLATE, baffle 2	2	

B11

FIG. 8 OIL PUMP

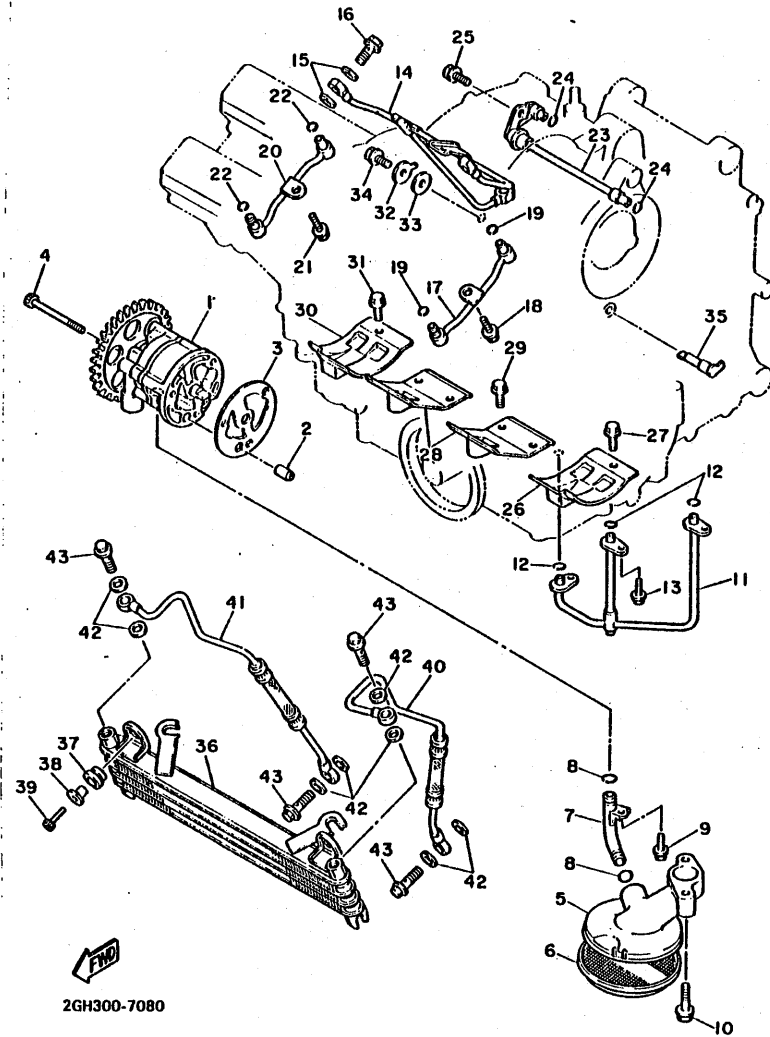

2GH300-7080

REF. NO.	PART NO.	DESCRIPTION	Q'TY	REMARKS
29	95026-06012	BOLT, flange	6	
30	2GH-15133-00	PLATE, baffle 3	1	
31	95026-06012	BOLT, flange	2	
32	90201-060K2	WASHER, Plate	1	
33	90430-06195	GASKET	1	
34	95821-06016	BOLT, flange	1	
35	1AE-13454-00	NOZZLE	1	
36	2GH-13470-00	OIL COOLER ASSY	1	
37	90480-12475	GROMMET	2	
38	90387-067K8	COLLAR	2	
39	91316-06020	BOLT	2	
40	2GH-13464-00	HOSE, oil 1	1	
41	2GH-13465-00	HOSE, oil 2	1	
42	90430-12202	GASKET	8	
43	90401-12122	BOLT, union	4	

FIG. 9 OIL CLEANER

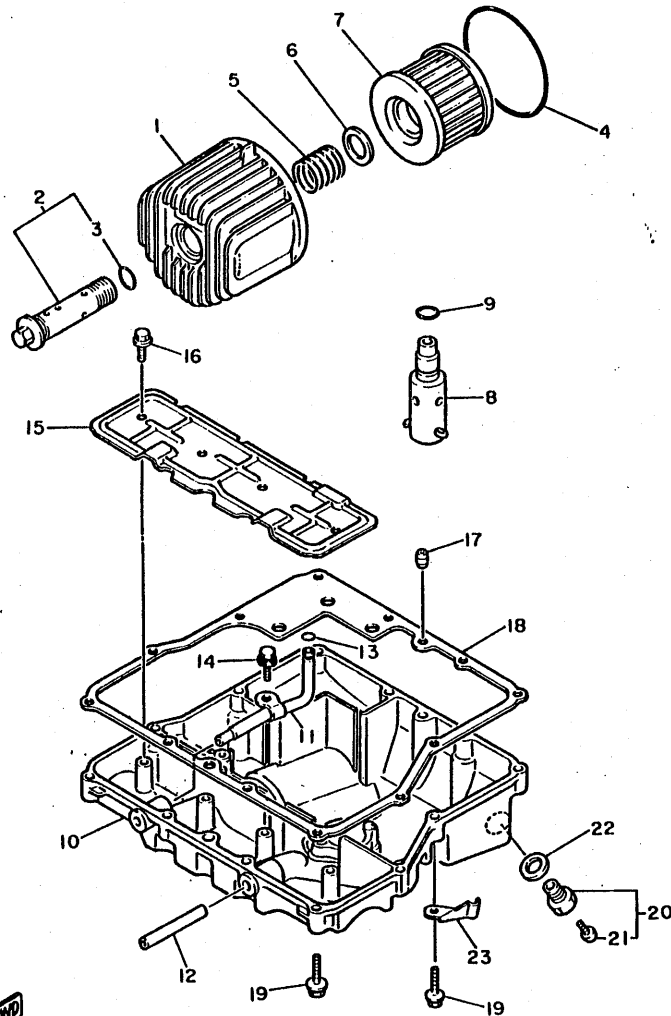

REF. NO.	PART NO.	DESCRIPTION	Q'TY	REMARKS
1	1AE-13447-00	COVER, oil element	1	
2	36Y-13340-00	BY-PASS VALVE ASSY	1	
3	93210-16629	O-RING	1	
4	93210-87723	O-RING	1	
5	90501-20422	SPRING, compression	1	
6	90201-21608	WASHER, Plate	1	
7	36Y-13441-00	ELEMENT, oil cleaner	1	
8	36Y-13490-00	RELIEF VALVE ASSY	1	
9	93210-15566	O-RING	1	
10	2GH-13417-00	COVER, strainer	1	
11	2GH-13416-00	PIPE, oil 1	1	
12	2GH-13418-00	PIPE, oil 2	1	
13	93210-08764	O-RING	1	
14	90119-06056	BOLT, with washer	1	
15	2GH-13337-00	PLATE, baffle lower	1	
16	95026-06010	BOLT, flange	4	
17	99510-08016	PIN, dowel	2	
18	1AE-13414-00	GASKET, strainer cover	1	
19	95026-06030	BOLT, flange	12	
20	11H-13455-00	PLUG	1	
21	98901-06008	SCREW, bind	1	
22	214-11198-01	GASKET	1	
23	90465-08076	CLAMP	1	



2GH300-7090

FIG. 10 INTAKE

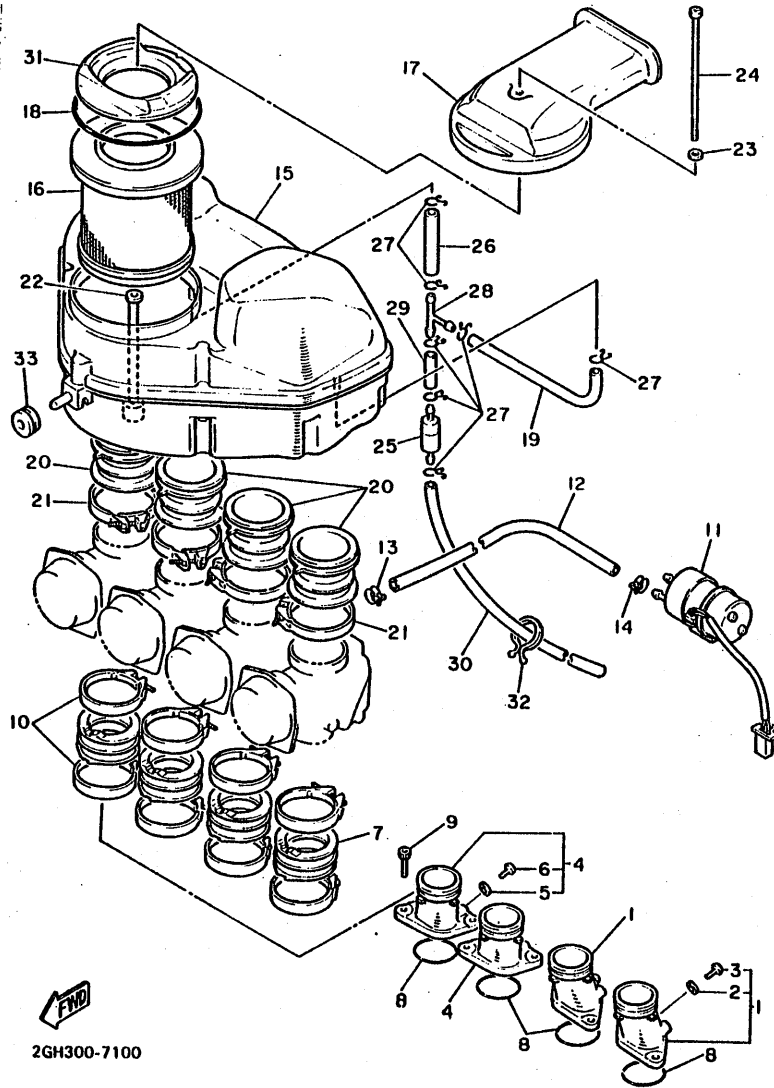

REF. NO.	PART NO.	DESCRIPTION	Q'TY	REMARKS
1	2GH-13586-00	JOINT, carburetor 1	2	#1, 2
2	90430-06014	.GASKET	1	
3	92501-06012	.SCREW, Pan head	1	
4	2GH-13596-00	JOINT, carburetor 2	2	#3, 4
5	90430-06014	.GASKET	1	
6	92501-06012	.SCREW, Pan head	1	
7	2GH-13597-00	JOINT, carburetor 3	4	
8	93210-40659	O-RING	4	
9	91316-06020	BOLT	8	
10	1AE-13575-00	BAND	8	
11	2GH-13907-00	FUEL PUMP COMP.	1	
12	90445-112F1	HOSE	1	
13	90460-12256	CLAMP, hose	1	
14	90460-11149	CLAMP, hose	1	
15	2GH-14401-00	AIR CLEANER CASE ASSY	1	
16	1AE-14451-00	ELEMENT, air cleaner	1	
17	2GH-14422-00	CAP, cleaner case 2	1	
18	1AE-14452-00	SEAL	1	
19	90445-11288	HOSE	1	
20	2GH-14453-01	JOINT, air cleaner 1	4	
21	90450-58016	HOSE CLAMP ASSY	4	
22	1AE-14443-00	COLLAR	1	
23	92990-06600	WASHER, Plate	1	
24	92511-06160	SCREW, Pan head	1	
25	4X7-2149Y-00	FILTER ASSY	1	
26	90445-112E9	HOSE	1	
27	90467-10008	CLIP	7	
28	90413-07007	WAY 3	1	



2GH300-7100

B14

FIG. 10 INTAKE

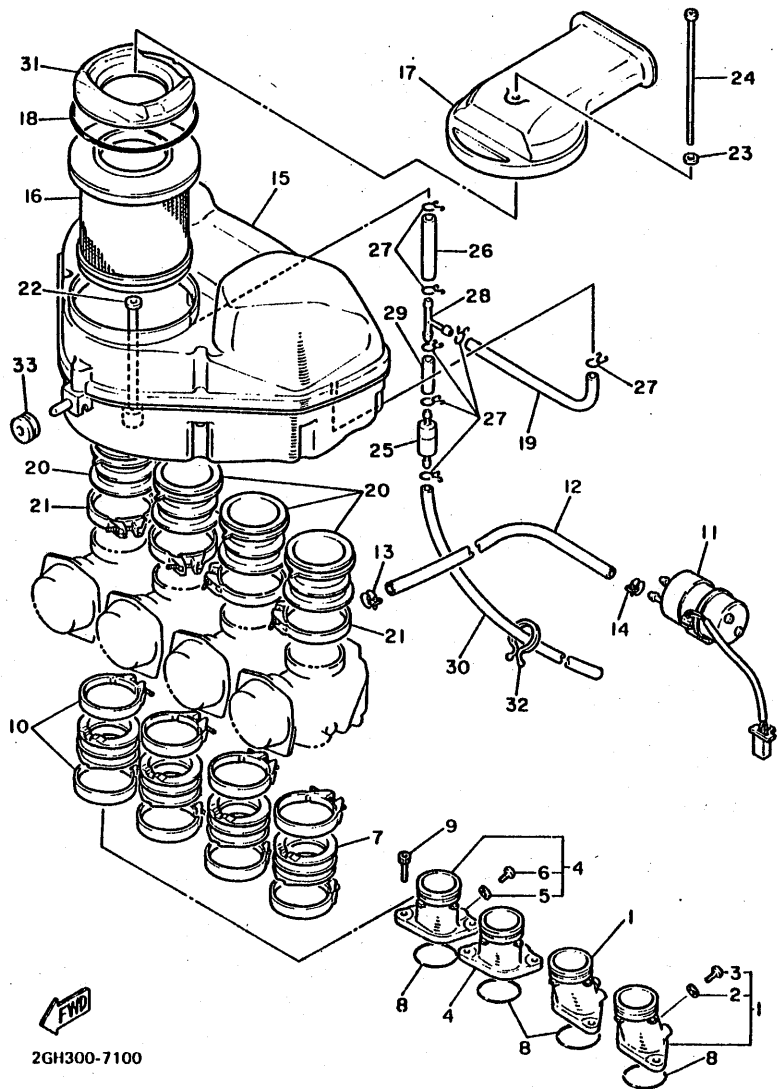

2GH300-7100

REF. NO.	PART NO.	DESCRIPTION	Q'TY	REMARKS
29	90445-11262	HOSE	1	
*30	90445-113F8	HOSE	1	
31	2GH-14432-00	SILENSER, inner	1	
32	90464-23041	CLAMP	1	
33	90480-18171	GROMMET	1	

B15

FIG. 11 CARBURETOR

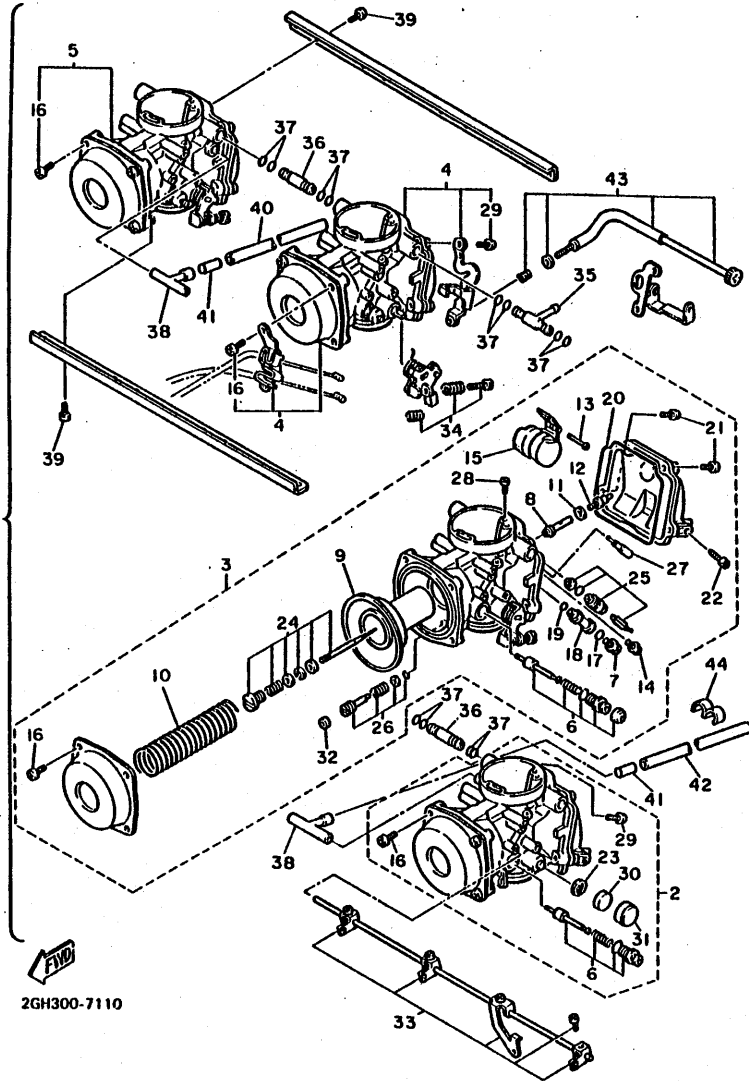

REF. NO.	PART NO.	DESCRIPTION	Q'TY	REMARKS
1	2GH-14900-00	CARBURETOR ASSY	1	
2	2GH-14901-00	•CARBURETOR ASSY 1	1	
3	2GH-14902-00	•CARBURETOR ASSY 2	1	
4	2GH-14903-00	•CARBURETOR ASSY 3	1	
5	2GH-14904-00	•CARBURETOR ASSY 4	1	
6	1AE-1410A-00	••STARTER SET	1	UR #1, 3
	1FN-1410A-00	••STARTER SET	1	UR #2, 4
7	620-1423A-72	••JET, main (#107.5)	1	UR #2, 3
	620-14231-22	••JET, main (#110)	1	UR #1, 4
8	1AE-14141-90	••NOZZLE, main	1	
9	2LH-14940-00	••DIAPHRAGM ASSY	1	
10	2LH-14933-00	••SPRING, diaPhraGm	1	
11	137-14153-00	••WASHER, main Jet	1	
12	1AE-14565-00	••SCREW	1	
13	353-14186-00	••PIN, float	1	
14	1FN-14565-00	••SCREW	1	
15	1WG-14985-00	••FLOAT	1	
16	98501-05010	••SCREW, Pan head	4	
17	1AE-14227-00	••WASHER	1	
18	2LH-14261-00	••HOLDER	1	
19	1AE-14237-00	••GASKET	1	
20	1FN-14147-00	••O-RING	1	
21	98503-04014	••SCREW, Pan head	4	UR #2, 4
	98503-04014	••SCREW, Pan head	2	UR #1, 3
22	12R-14191-00	••PLUG, drain	1	
23	812-14137-00	••CLIP	1	#1, 4
24	2LE-1490J-00	••NEEDLE SET	1	
25	1FN-14107-15	••NEEDLE VALVE SET	1	

FIG. 11 CARBURETOR

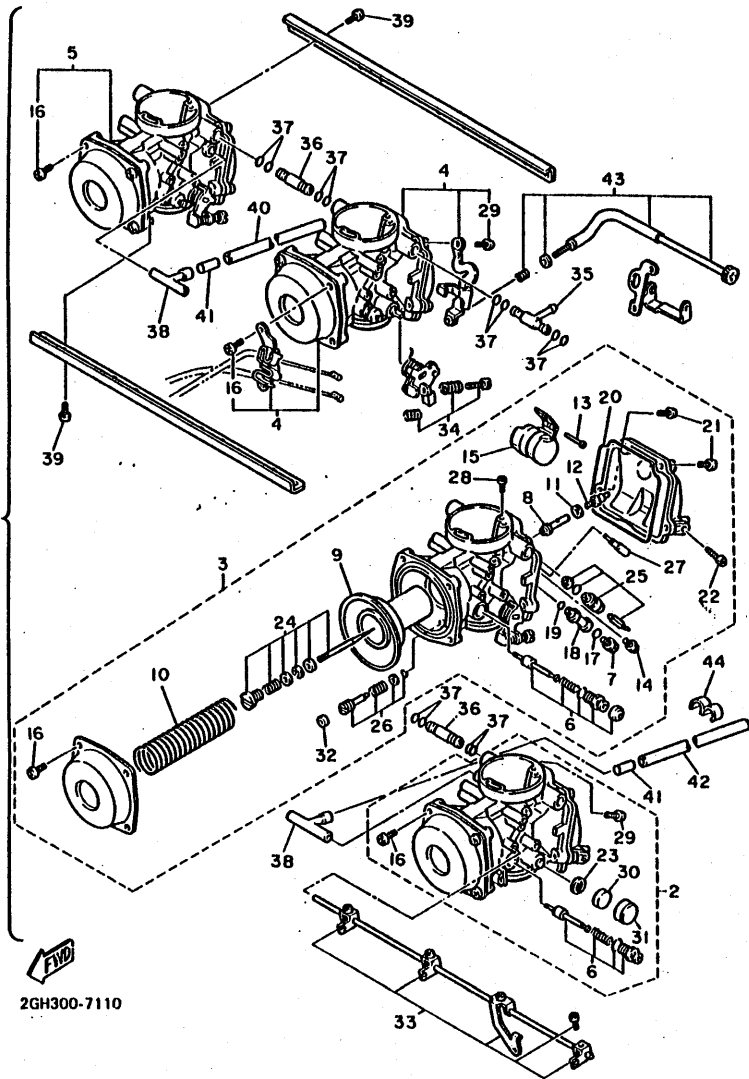

2GH300-7110

REF. NO.	PART NO.	DESCRIPTION	Q'TY	REMARKS
26	12R-14105-00	..PILOT SCREW SET	1	
27	3HI-14142-20	..JET, Pilot (# 20)	1	
28	830-14231-23	..JET, main (#115)	1	
29	98511-04016	..SCREW, Pan head	2	#1, 3
30	36X-14169-00	..CAP	1	#1, 4
31	1AE-14169-00	..CAP	1	#1, 4
32	1HX-14991-00	..PLUG, screw	1	
33	2LH-1490L-00	..STARTER LEVER SET, 1	1	
34	1FN-1490K-01	..STOP SCREW SET	3	
35	1HX-14251-00	..NIPPLE	1	
36	16H-14251-00	..NIPPLE	2	
37	36Y-14147-00	..O-RING	12	
38	1AE-14197-00	..PIPE	2	
39	98501-05010	..SCREW, Pan head	16	
40	2LH-14197-00	..PIPE	1	
41	1FN-14918-00	..RING	2	
42	2GH-14197-00	..PIPE	1	
43	2LE-14103-00	..THROTTLE SCREW SET	1	
44	90464-10075	CLAMP	1	

FIG. 12 EXHAUST

REF. NO.	PART NO.	DESCRIPTION	Q'TY	REMARKS
1	2LL-14710-00	MUFFLER ASSY 1	1	
2	90101-06576	.BOLT	4	
3	92906-06600	.WASHER, Plate	4	
4	90179-06500	NUT	8	
5	5Y1-14613-00	GASKET, exhaust Pipe .	4	
6	2GH-14791-00	STAY, muffler	1	
7	46X-14737-00	.DAMPER, muffler	1	
8	90110-08096	BOLT, hexagon socket head	2	
9	90201-081H4	WASHER, Plate	1	
10	90109-083A8	BOLT	1	

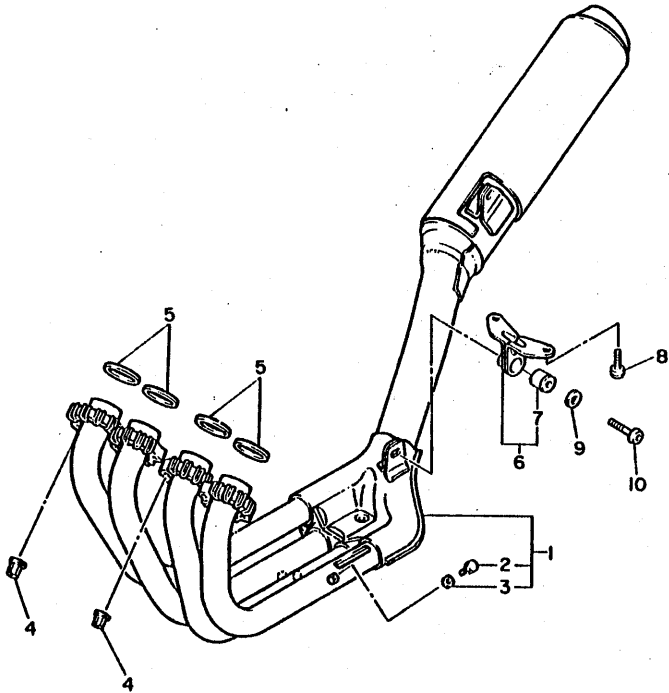

2GH300-7120

C4

FIG. 13 CRANKCASE

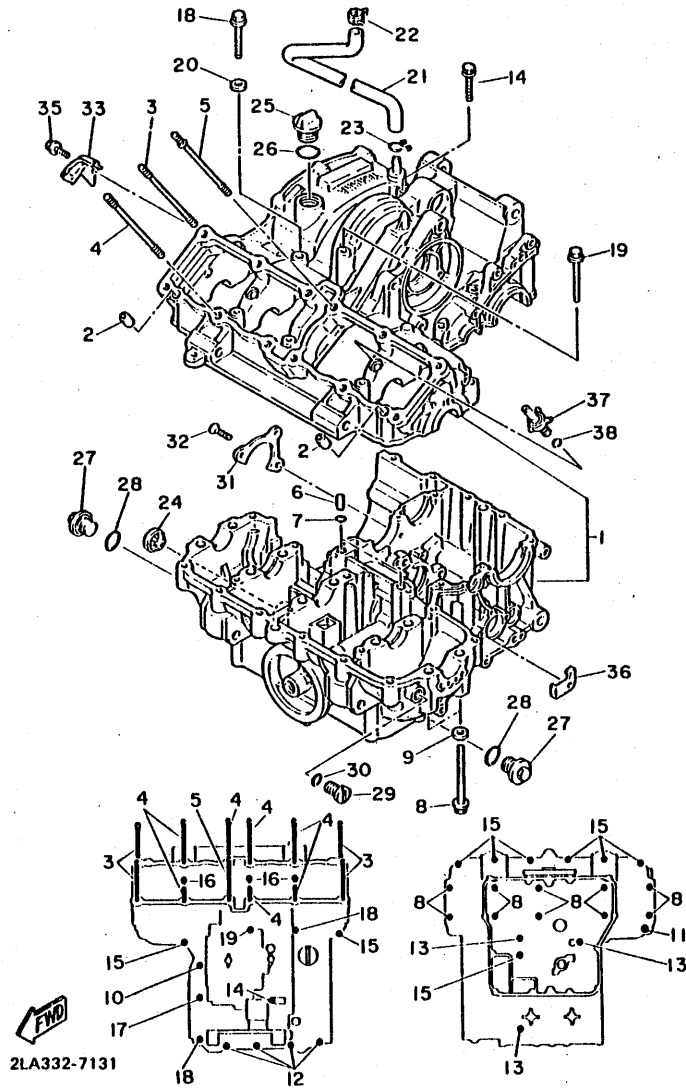

2LA332-7131

REF. NO.	PART NO.	DESCRIPTION	Q'TY	REMARKS
1	2GH-15100-01	CRANKCASE ASSY	1	
2	99530-10014	PIN, dowel	2	
3	90116-09458	BOLT, stud	4	
4	90116-09500	BOLT, stud	7	
5	90116-09501	BOLT, stud	1	
6	90387-05383	COLLAR	2	
7	93210-07135	O-RING	2	
8	90105-09373	BOLT, washer based	10	
9	90201-096J9	WASHER, Plate	4	
10	95816-06035	BOLT, flange	1	
11	95816-08045	BOLT, flange	1	
12	95816-06060	BOLT, flange	4	
13	95816-06080	BOLT, flange	3	
14	95816-06140	BOLT, flange	1	
15	95816-08045	BOLT, flange	9	
16	95816-08055	BOLT, flange	3	
17	95816-08065	BOLT, flange	1	
18	95816-08090	BOLT, flange	2	
19	95816-08135	BOLT, flange	1	
20	90201-08087	WASHER, Plate	1	
21	1AE-11166-00	PIPE, breather 1	1	
22	90467-15054	CLIP	1	
23	90467-14056	CLIP	1	
24	4H7-15361-00	GAUGE, level	1	
25	2H9-15363-00	PLUG, oil	1	
26	93210-27194	O-RING	1	
27	4K0-15189-00	PLUG	2	
28	93210-20573	O-RING	2	

FIG. 13 CRANKCASE

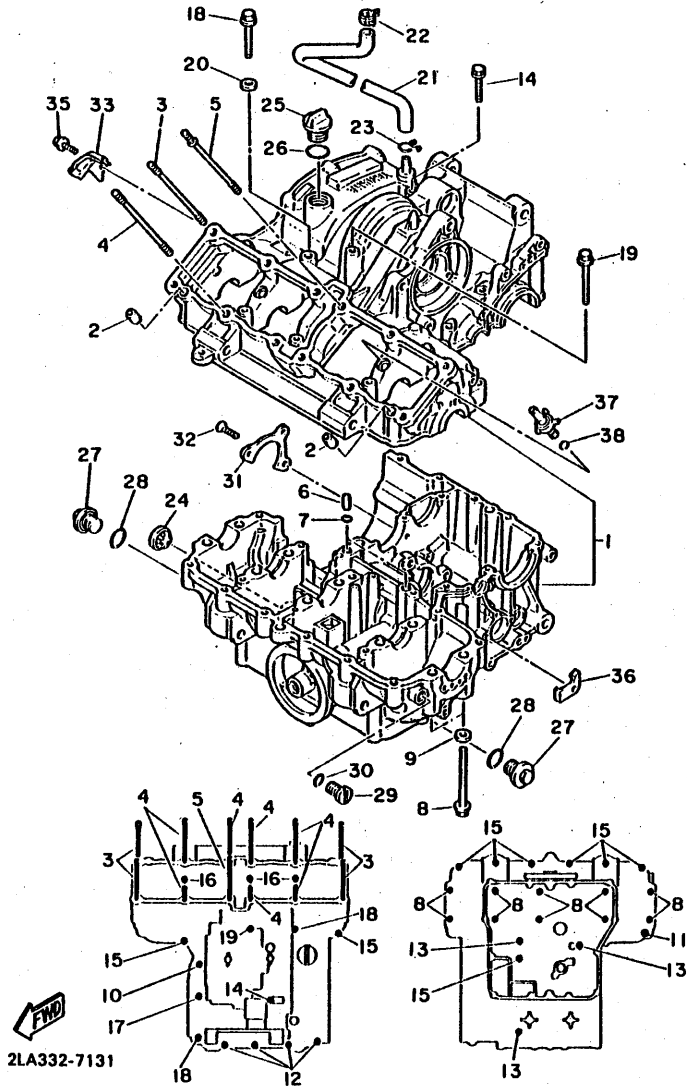

REF. NO.	PART NO.	DESCRIPTION	Q'TY	REMARKS
29	90340-14079	PLUG, straight screw	1	
30	93210-14369	O-RING	1	
31	1AE-15383-00	PLATE, bearing cover	1	
32	90151-06014	SCREW, countersunk	3	
33	90465-08281	CLAMP	1	
35	95026-06012	BOLT, flange	1	
36	90462-08158	CLAMP	1	
*37	2GH-15105-01	NOZZLE ASSY	2	
38	93210-06632	O-RING	2	

FIG. 14 CRANKCASE COVER 1

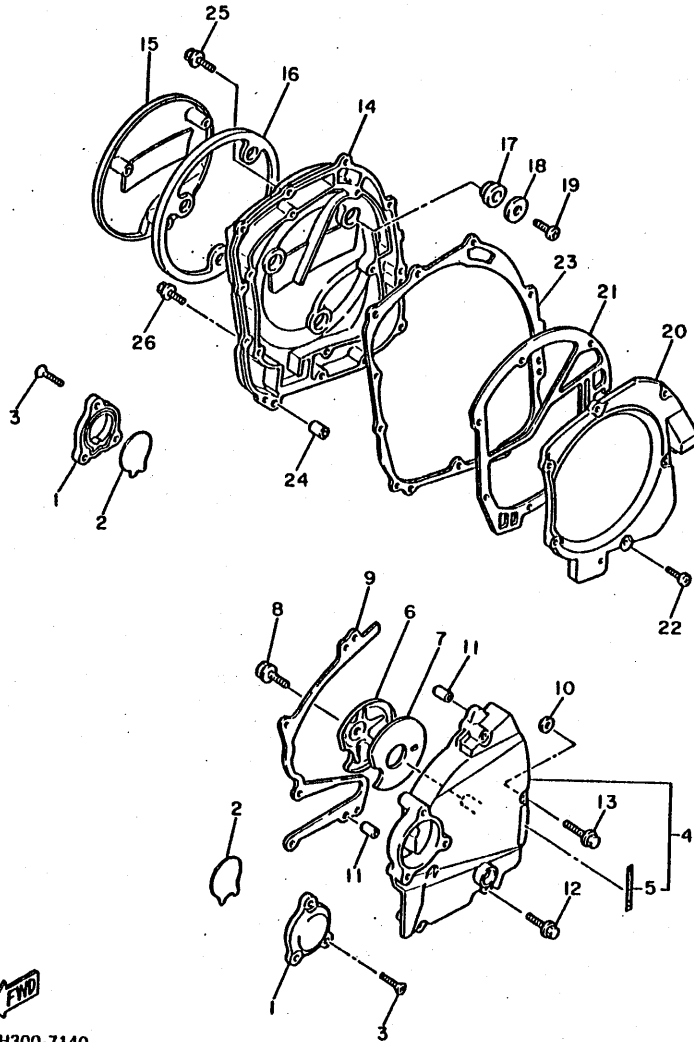

REF. NO.	PART NO.	DESCRIPTION	Q'TY	REMARKS
1	1TV-15416-00	COVER, oil Pump	2	
2	1AE-15456-00	GASKET, oil Pump cover 1	2	
3	90152-06014	SCREW, countersunk	6	
4	2GH-15410-00	CRANKCASE COVER ASSY 1	1	
5	2GH-15435-00	EMBLEM	1	
6	1AE-15427-01	COVER, cap 2	1	
7	1AE-15316-00	DAMPER, engine mount 1	1	
8	95811-06012	BOLT, flange	1	
9	1AE-15451-00	GASKET, crankcase cover 1	1	
10	36Y-15467-00	GASKET	1	
11	91810-18013	PIN, dowel	2	
12	95026-06040	BOLT, flange	3	
13	95026-06050	BOLT, flange	2	
14	2GH-15421-00	COVER, crankcase 2	1	
15	1TV-15417-00	COVER, cap	1	
16	1AE-15449-00	RING, rubber	1	
17	4H7-15486-00	GROMMET	3	
18	90209-06096	WASHER	3	
19	92501-06010	SCREW, Pan head	3	
20	2GH-15346-00	BREATHER 1	1	
21	2GH-15463-00	GASKET, carburetor cover 2	1	
22	92501-06020	SCREW, Pan head	6	
23	2GH-15461-00	GASKET, crankcase cover 2	1	
24	91810-18013	PIN, dowel	2	
25	95026-06030	BOLT, flange	2	
26	95026-06020	BOLT, flange	9	

2GH300-7140

FIG. 15 STARTER

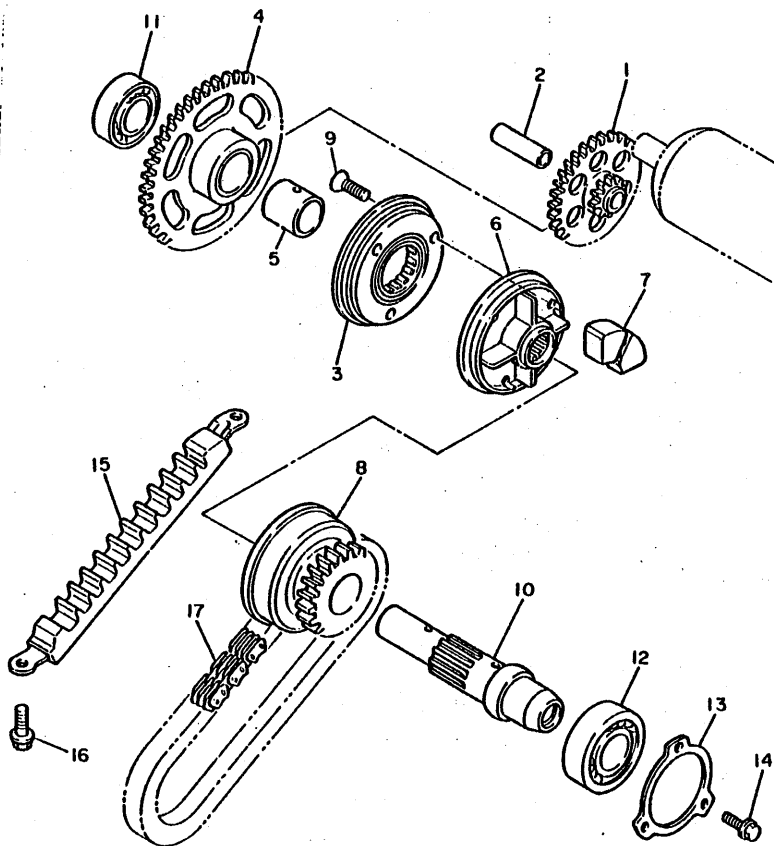

REF. NO.	PART NO.	DESCRIPTION	Q'TY	REMARKS
1	2GH-15512-00	GEAR, idler 1	1	
2	1AE-15521-00	SHAFT 1	1	
3	2GH-15590-00	STARTER CHAIN GUIDE ASSY	1	
4	2GH-15517-00	GEAR, idler 2	1	
5	90387-202A7	COLLAR	1	
6	2GH-15524-00	WHEEL, starter	1	
7	4H7-16155-01	ABSORBER 1	4	
8	2GH-15519-00	SPROCKET, starter 2	1	
9	90151-08022	SCREW, countersunk	3	
*10	1AE-15522-01	SHAFT 2	1	
11	93306-00421	BEARING	1	
12	93306-20541	BEARING (B6205)	1	
13	1AE-15381-00	PLATE, bearing cover	1	
14	95026-06016	BOLT, flange	3	
15	1AE-11474-00	GUIDE, upper	1	
16	95816-06014	BOLT, flange	2	
17	36Y-11456-00	CHAIN, Primary	1	



2GH300-7150

FIG. 16 CLUTCH

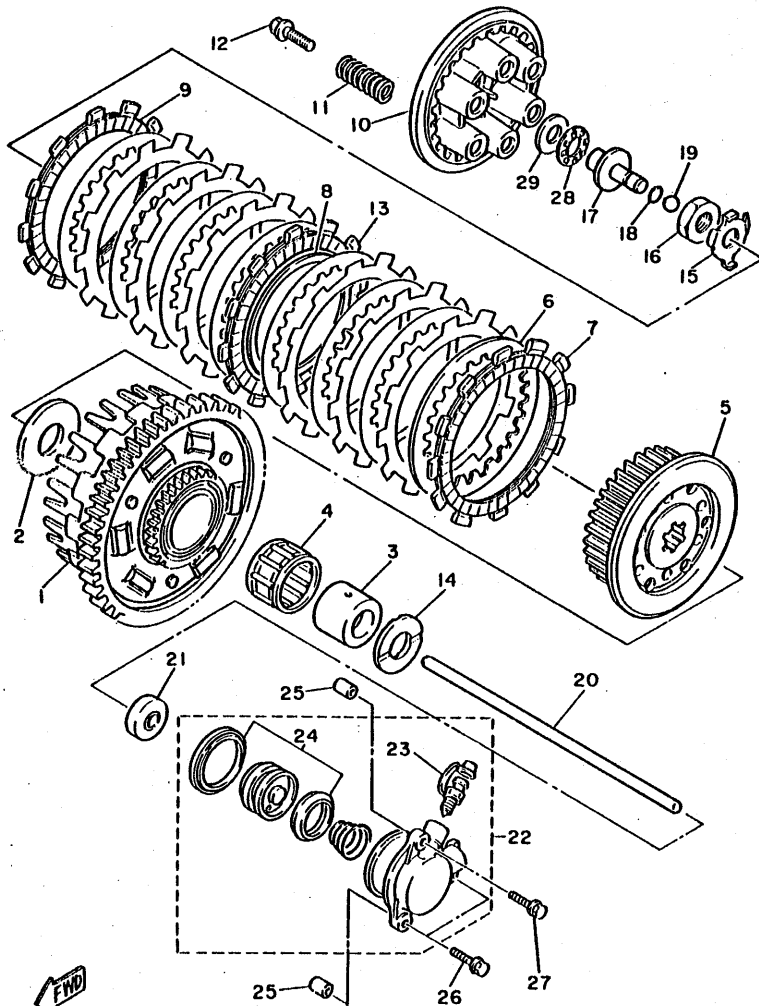

2GH300-7160

REF. NO.	PART NO.	DESCRIPTION	Q'TY	REMARKS
1	2GH-16150-00	PRIMARY DRIVEN GEAR COMP.	1	
2	1AE-16154-00	PLATE, thrust 1	1	
3	90560-25270	SPACER	1	
4	93310-340N8	BEARING, cylindrical	1	
5	2GH-16371-00	BOSS, clutch	1	
6	31A-16325-00	PLATE, clutch 2	8	
7	4H7-16321-00	PLATE, friction	7	
8	5Y1-16383-00	SPRING, clutch boss	1	
9	31A-16321-00	PLATE, friction	1	
10	5BL-16351-00	PLATE, Pressure 1	1	
11	90501-225A9	SPRING, compression	6	
12	90159-06123	SCREW, with washer	6	
13	5Y1-16331-01	PLATE, friction 2	1	
14	1AE-16164-00	PLATE, thrust 2	1	
15	90215-20231	WASHER, lock	1	
16	90170-20327	NUT	1	
17	1LJ-16356-00	ROD, Push 1	1	
18	93210-06632	O-RING	1	
19	93511-32027	BALL	1	
20	1AE-16357-00	ROD, Push 2	1	
21	371-15389-00	SEAL, Push rod	1	
22	1TV-16381-00	PUSH LEVER COMP.	1	
23	36Y-W0048-00	.BREED SCREW KIT	1	
24	26H-W0098-00	.PUSH LEVER SEAL KIT	1	
25	91810-18013	PIN, dowel	2	
26	95026-06030	BOLT, flange	2	
27	95026-06090	BOLT, flange	1	
28	93340-21505	BEARING	1	
29	90201-150H2	WASHER, Plate	1	

C9

FIG. 17 TRANSMISSION

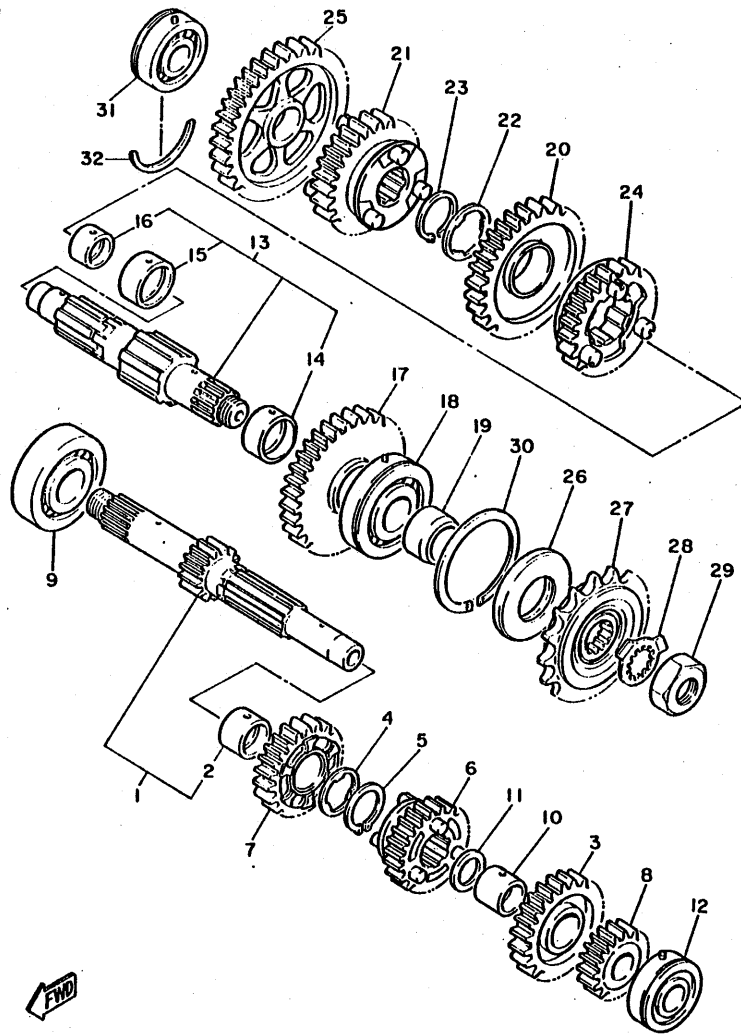

REF. NO.	PART NO.	DESCRIPTION	Q'TY	REMARKS
1	2GH-W1741-00	MAIN AXLE ASSY	1	
2	90387-253M6	.COLLAR	1	
3	2GH-17151-00	GEAR, 5th Pinion (27T)	1	
4	90209-22191	WASHER	1	
5	93440-25084	CIRCLIP	1	
6	2GH-17131-00	GEAR, 3rd Pinion (21T)	1	
7	2GH-17141-00	GEAR, 4th Pinion (23T)	1	
8	2GH-17121-00	GEAR, 2nd Pinion (18T)	1	
9	93306-30525	BEARING (B6305)	1	
10	90387-203M7	COLLAR	1	
11	90201-200K3	WASHER, Plate	1	
12	93306-20455	BEARING	1	
13	2GH-W1742-00	DRIVE AXLE ASSY	1	
14	90387-271T7	.COLLAR	1	
15	90387-281T8	.COLLAR	1	
16	90387-211T9	.COLLAR	1	
17	2GH-17221-00	GEAR, 2nd wheel (32T)	1	
18	93306-30546	BEARING (B6305A5 SPECIAL)	1	
19	90387-253M9	COLLAR	1	
20	2GH-17231-00	GEAR, 3rd wheel (29T)	1	
21	2GH-17241-00	GEAR, 4th wheel (27T)	1	
22	90209-25196	WASHER	1	
23	93440-28062	CIRCLIP	1	
24	2GH-17251-00	GEAR, 5th wheel (28T)	1	
25	2GH-17211-00	GEAR, 1st wheel (36T)	1	
26	93102-35109	OIL SEAL	1	
27	2GH-17460-00	SPROCKET, drive 16l(2GH1746160)	1	
28	90215-21022	WASHER, lock	1	



2GH300-7170

C10

FIG. 17 TRANSMISSION

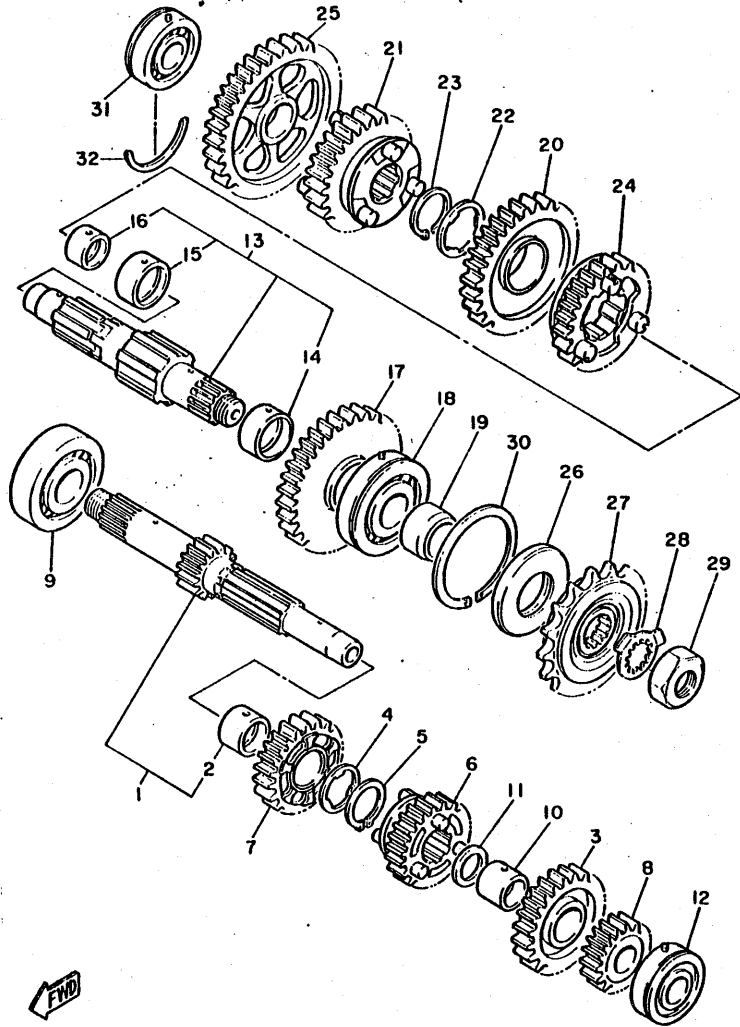

REF. NO.	PART NO.	DESCRIPTION	Q'TY	REMARKS
29	90179-18020	NUT	1	
30	278-17424-01	CIRCLIP 1	1	
31	93306-20455	BEARING	1	
32	93440-45144	CIRCLIP	1	

FWD

2GH300-7170

C11

FIG. 18 SHIFT CAM. FORK

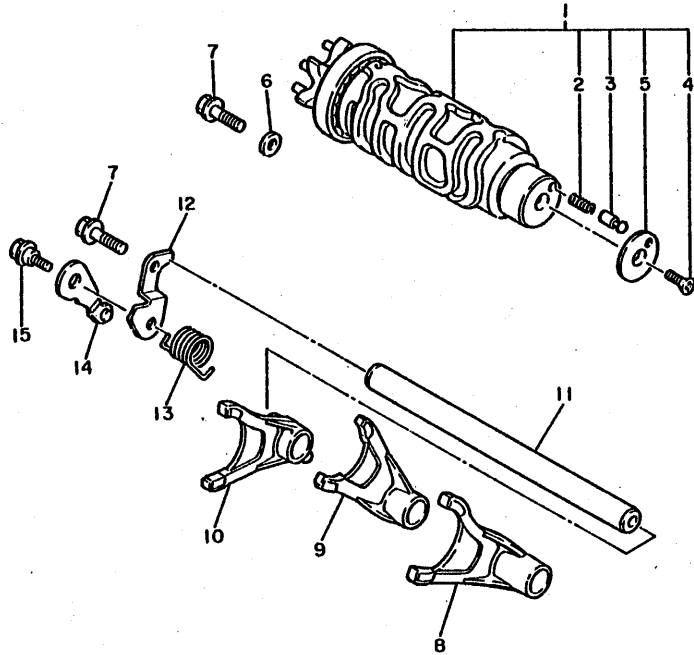

REF. NO.	PART NO.	DESCRIPTION	Q'TY	REMARKS
1	2GH-18540-00	SHIFT CAM ASSY	1	
2	90501-06022	•SPRING, comPression	1	
3	278-18542-00	•POINT, neutral	1	
4	98701-05012	•SCREW, flat head	1	
5	278-18566-00	•PLATE, side 2	1	
6	90201-06643	WASHER, Plate	1	
7	95822-06016	BOLT, flange	2	
8	2GH-18511-00	FORK, shift 1	1	
9	2GH-18512-00	FORK, shift 2	1	
10	2GH-18513-00	FORK, shift 3	1	
11	12R-18531-00	BAR, shift fork Guide 1	1	
12	1AE-18536-00	STOPPER, shift bar	1	
13	90508-26681	SPRING, torsion	1	
14	36Y-18140-00	STOPPER LEVER ASSY	1	
15	90109-065A9	BOLT	1	



1FN310-5180

FIG. 19 SHIFT SHAFT

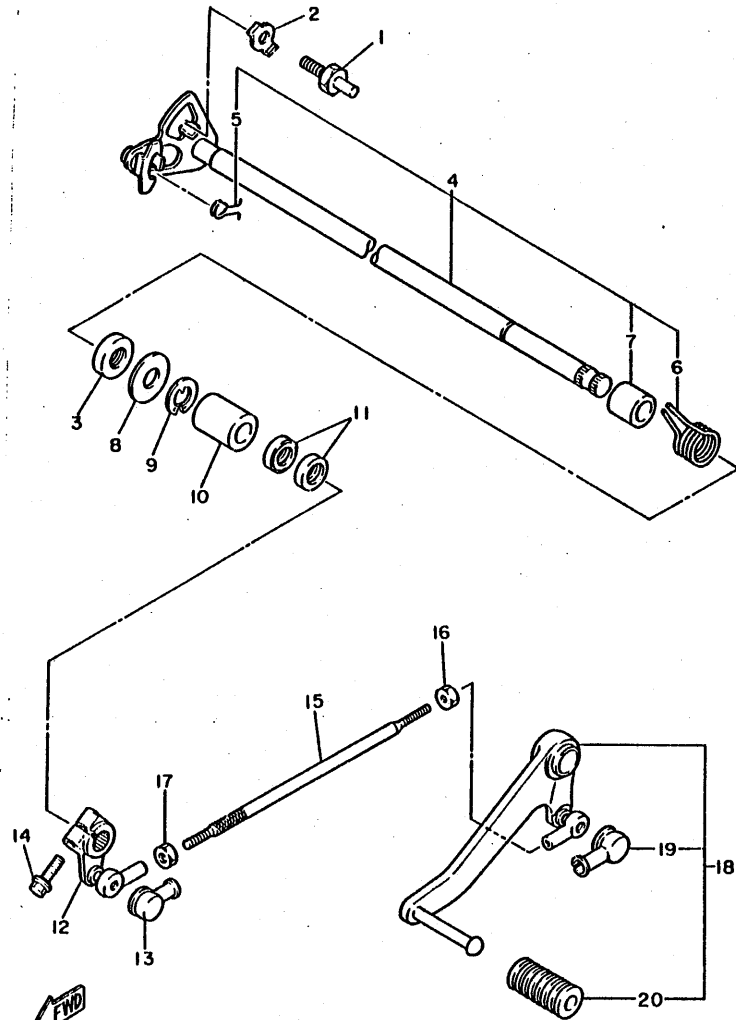

2GH300-7190

C13

REF. NO.	PART NO.	DESCRIPTION	Q'TY	REMARKS
1	4G0-18127-00	STOPPER, screw	1	
2	90215-08115	WASHER, lock	1	
3	93102-12106	OIL SEAL	1	
4	1AE-18101-00	SHIFT SHAFT ASSY	1	
5	90508-10514	.SPRING, torsion	1	
6	90508-32682	.SPRING, torsion	1	
7	90387-114K8	.COLLAR	1	
8	90201-12575	WASHER, Plate	1	
9	99001-10600	CIRCLIP	1	
10	90560-12191	SPACER	1	
11	93109-12053	OIL SEAL	2	
12	2GH-18112-00	ARM, shift	1	
13	2H9-18154-00	COVER, dust	1	
14	91026-06020	BOLT, flange	1	
15	46X-18115-00	ROD, shift	1	
16	90170-06228	NUT	1	
17	95303-06700	NUT	1	
18	2GH-18110-00	SHIFT PEDAL ASSY	1	
19	2H9-18154-00	.COVER, dust	1	
20	132-18113-01	.COVER, shift Pedal	1	

FIG. 20 FRAME

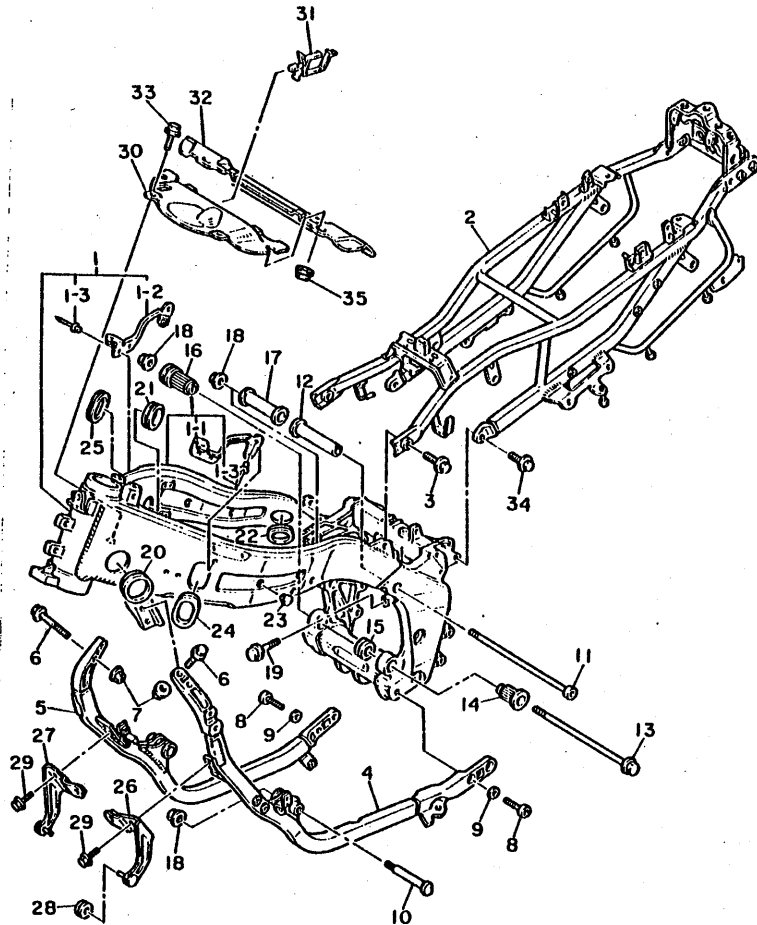

FWD
2LL700-7201

REF. NO.	PART NO.	DESCRIPTION	Q'TY	REMARKS
* 1	2GH-21110-03	FRAME COMP.	1	
*1-1	2GH-2833J-00	.BRACKET 12	1	
*1-2	2GH-2833K-00	.BRACKET 13	1	
*1-3	90267-40087	.RIVET, blind	6	
2	2GH-21190-00-35	REAR FRAME COMP.	1	silver
* 3	90105-10459	BOLT, washer based	2	
4	2LM-21140-00-35	DOWN TUBE COMP.	1	silver
5	2GH-21150-00-35	DOWN TUBE COMP.2	1	silver
6	90105-10496	BOLT, washer based	4	
7	95601-10200	NUT, self-locking	4	
8	90110-08150	BOLT, hexagon socket head	4	
9	90201-086J0	WASHER, Plate	4	
10	90109-103E4	BOLT	2	
11	90110-10154	BOLT, hexagon socket head	1	
12	90387-113T1	COLLAR	1	
13	90105-10476	BOLT, washer based	1	
14	1UF-2139X-00	DAMPER	1	
15	1UF-2139U-00	DAMPER 2	1	
16	2GH-15316-00	DAMPER, engine mount 1	1	
17	1WG-21459-00	SPACER	1	
18	90179-10247	NUT	4	
19	90105-08475	BOLT, washer based	1	
20	90480-35394	GROMMET	2	
21	2GH-2117M-00	COVER 2	2	
22	2GH-2117T-00	COVER 5	2	
23	90338-15202	PLUG	4	
24	2GH-2117N-00	COVER 3	1	
25	2GH-2117R-00	COVER 4	1	
26	2GH-2136A-00	BRACKET, cooler 1	1	
27	2GH-2136E-00	BRACKET, cooler 2	1	
28	90480-13383	GROMMET	2	

FIG. 21 FENDER

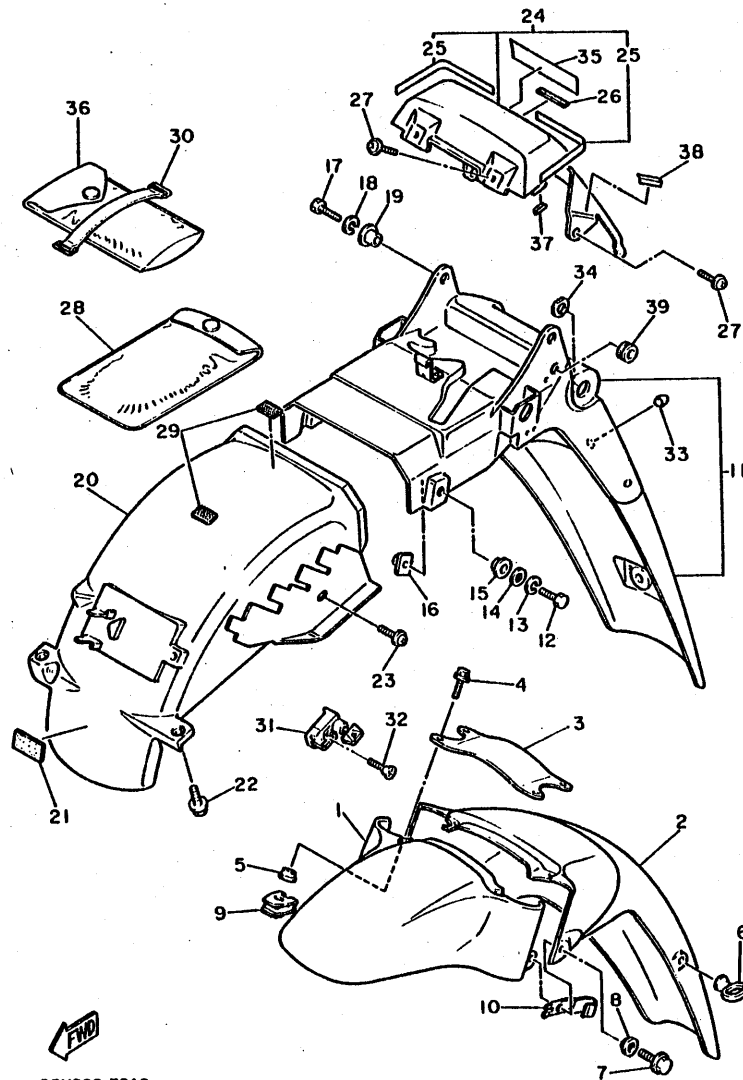

2GH300-7210

REF. NO.	PART NO.	DESCRIPTION	Q'TY	REMARKS
* 1	2GH-21511-00-GE	FENDER, front	1	UR silky white
	2GH-21511-00-JW	FENDER, front	1	UR urushi black
* 2	2GH-21556-00-GE	FENDER, front 2	1	UR silky white
	2GH-21556-00-JW	FENDER, front 2	1	UR urushi black
3	47X-2313A-00	BRACE, fork	1	
4	90105-06478	BOLT, washer based	4	
5	90387-065T2	COLLAR	4	
6	1A8-21518-00	HOLDER, cable	1	
7	90105-06477	BOLT, washer based	2	
8	90387-064J1	COLLAR	2	
9	90183-08043	NUT, spring	4	
10	2GH-25875-00	HOLDER, brake hose 1	2	
11	2GH-W2161-00	REAR FENDER COMP.	1	
12	97001-06020	BOLT	2	
13	92990-06100	WASHER, spring	2	
14	92901-06600	WASHER, plate	2	
15	90387-061M0	COLLAR	2	
16	31A-14477-00	PLATE	2	
17	97313-06016	BOLT	2	
18	92990-06100	WASHER, spring	2	
19	90387-064L2	COLLAR	2	
20	2GH-21629-00	GUARD, mud	1	
21	29N-21747-00	DAMPER	1	
22	90119-06052	BOLT, with washer	2	
23	90159-06056	SCREW, with washer	1	
* 24	2GH-W2165-00-0X	COVER, rear fender	1	UR silky white / atlantic blue
	2GH-21651-00-VA	COVER, rear fender	1	UR dynasty blue
	2GH-21651-00-JW	COVER, rear fender	1	UR urushi black
25	2GH-21660-00	GRAPHIC	1	for sw/abl
26	2KT-21649-00	DAMPER	1	
27	90159-06042	SCREW, with washer	4	

FIG. 21 FENDER

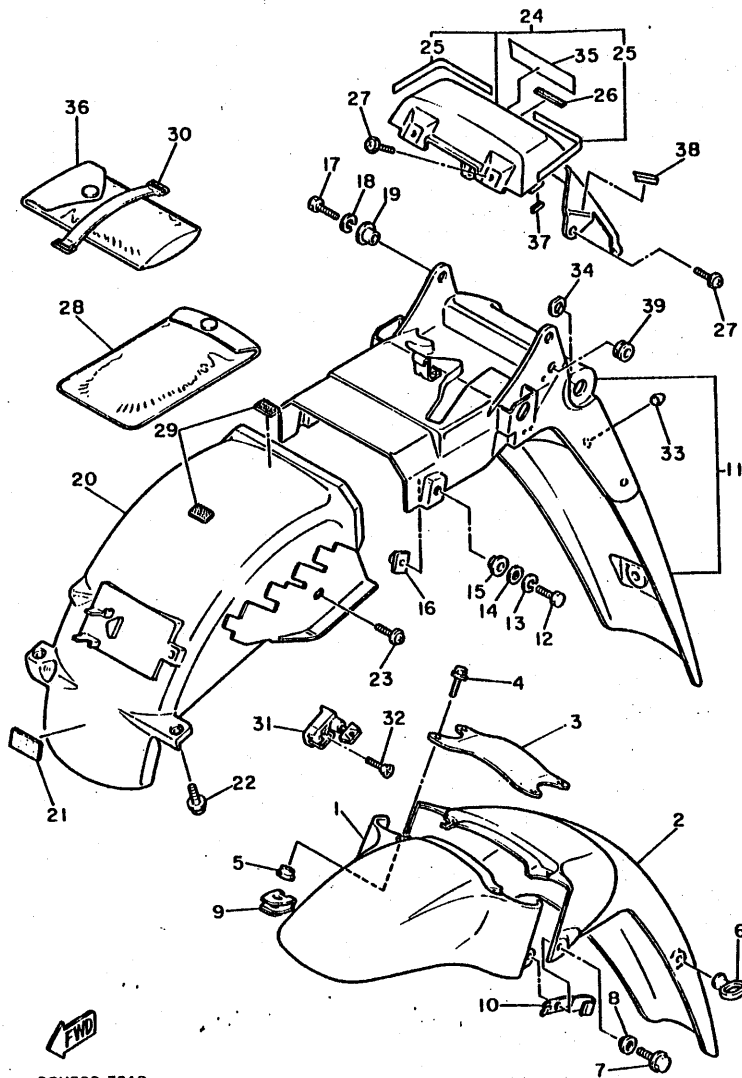

2GH300-7210

REF. NO.	PART NO.	DESCRIPTION	Q'TY	REMARKS
28	4K5-28186-00	POUCH	1	
29	4K5-2814E-10	HOOK	2	
30	122-82131-00	BAND, battery	1	
31	26H-21308-00	HELMET HANGER ASSY	1	
32	90149-06150	SCREW	1	
33	4G0-21639-00	DAMPER 2	1	
34	90214-12033	WASHER, claw	2	
*35	99234-00020	EMBLEM, yamaha	1	UR for sw/abl
	99231-00020	EMBLEM, yamaha	1	UR for dyb
	99236-00020	EMBLEM, yamaha	1	UR for urb
36	2GH-28100-10	TOOL KIT	1	
37	2GH-21732-00	SEAL 1	2	
38	2GH-21735-00	SEAL 2	2	
39	90480-10258	GROMMET	2	

D3

FIG. 22 SIDE COVER

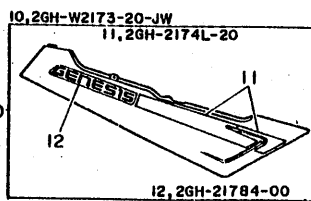
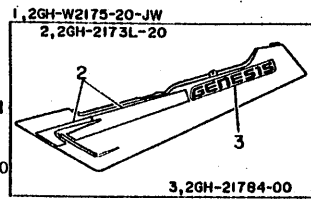
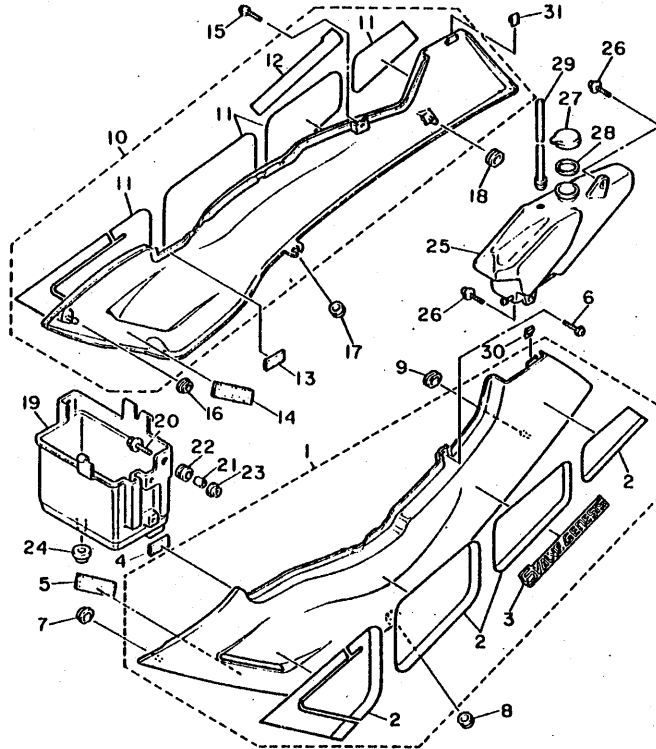
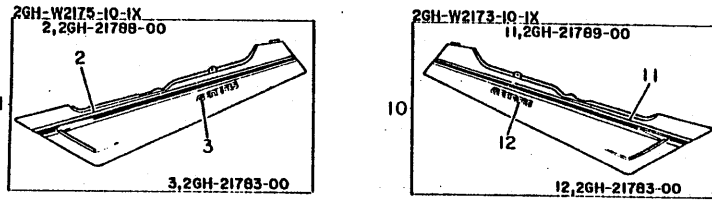

REF. NO.	PART NO.	DESCRIPTION	Q'TY	REMARKS
*1	2GH-W2175-00-GE	SIDE COVER 1	1	UR silky white
	2GH-W2175-20-JW	SIDE COVER 1	1	UR urushi black
	2GH-W2175-10-1X	SIDE COVER 1	1	UR silky white- /dynasty blue UR for sw
*2	2GH-2173L-00	.GRAPHIC SET 1	1	UR for sw
	2GH-21788-00	.GRAPHIC	1	UR for sw / dyb
	2GH-2173L-20	.GRAPHIC SET 2	1	UR for urb
*3	2GH-21781-00	.EMBLEM 1	1	UR for sw
	2GH-21783-00	.EMBLEM 3	1	UR for sw / dyb
	2GH-21784-00	.EMBLEM 4	1	UR for urb
4	5G3-21747-00	DAMPER	1	
5	1KH-21717-00	DAMPER, side cover	1	
6	90159-06033	SCREW, with washer	1	
7	90480-14074	GROMMET	1	
8	90480-12320	GROMMET	1	
9	90480-22084	GROMMET	1	
*10	2GH-W2173-00-GE	SIDE COVER COMP 2	1	UR silky white
	2GH-W2173-20-JW	SIDE COVER COMP 2	1	UR urushi black
	2GH-W2173-10-1X	SIDE COVER COMP 2	1	UR silky white- /dynasty blue UR for sw
*11	2GH-2174L-00	.GRAPHIC SET 2	1	UR for sw
	2GH-21789-00	.GRAPHIC	1	UR for sw / dyb
	2GH-2174L-20	.GRAPHIC SET 2	1	UR for urb
*12	2GH-21781-00	.EMBLEM 1	1	UR for sw
	2GH-21783-00	.EMBLEM 3	1	UR for sw / dyb
	2GH-21784-00	.EMBLEM 4	1	UR for urb
13	5G3-21747-00	DAMPER	1	
14	1KH-21717-00	DAMPER, side cover	1	
15	90159-06033	SCREW, with washer	1	
16	90480-14074	GROMMET	1	
17	90480-12320	GROMMET	1	
18	90480-22084	GROMMET	1	
19	2GH-21245-00	BOX	1	
20	90119-06097	BOLT, with washer	2	
21	90387-060A7	COLLAR	2	
22	90480-16233	GROMMET	2	

D4

2LA332-7220

FIG. 22 SIDE COVER

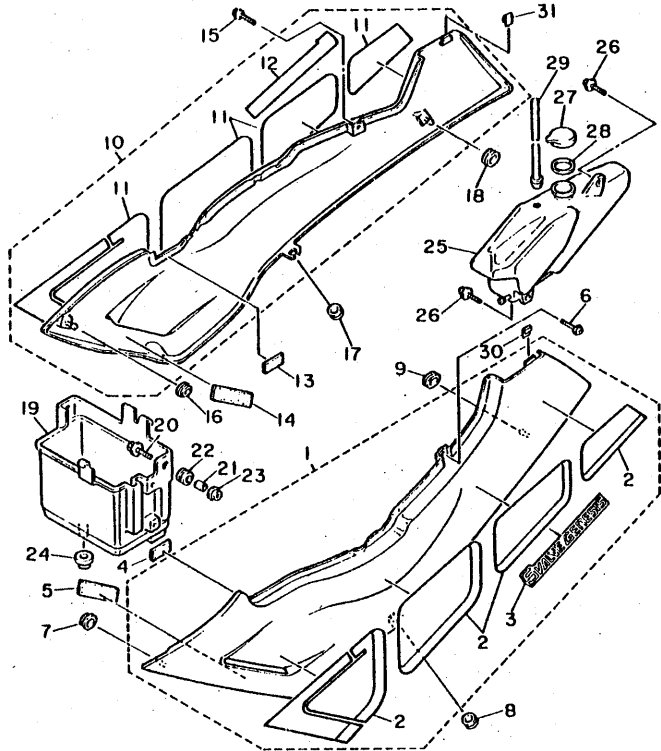
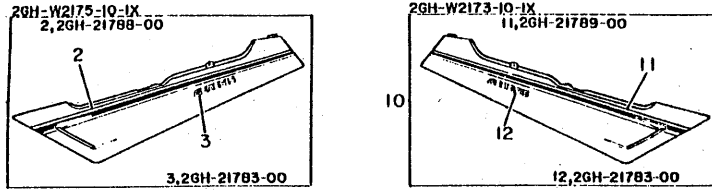

REF. NO.	PART NO.	DESCRIPTION	Q'TY	REMARKS
23	95701-06500	NUT, flange	2	
24	90480-23192	GROMMET	1	
25	2GH-21871-00	TANK, recovery	1	
26	90159-06056	SCREW, with washer	2	
27	4L0-21875-00	CAP	1	
28	1AA-21874-00	GASKET	1	
29	1KF-21816-00	PIPE 1	1	
30	2GH-21732-00	SEAL 1	1	
31	2GH-21732-00	SEAL 1	1	

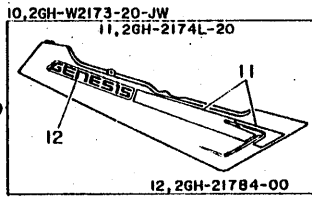
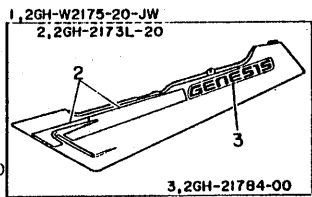

2LA332-7220

D5

FIG. 23 REAR ARM

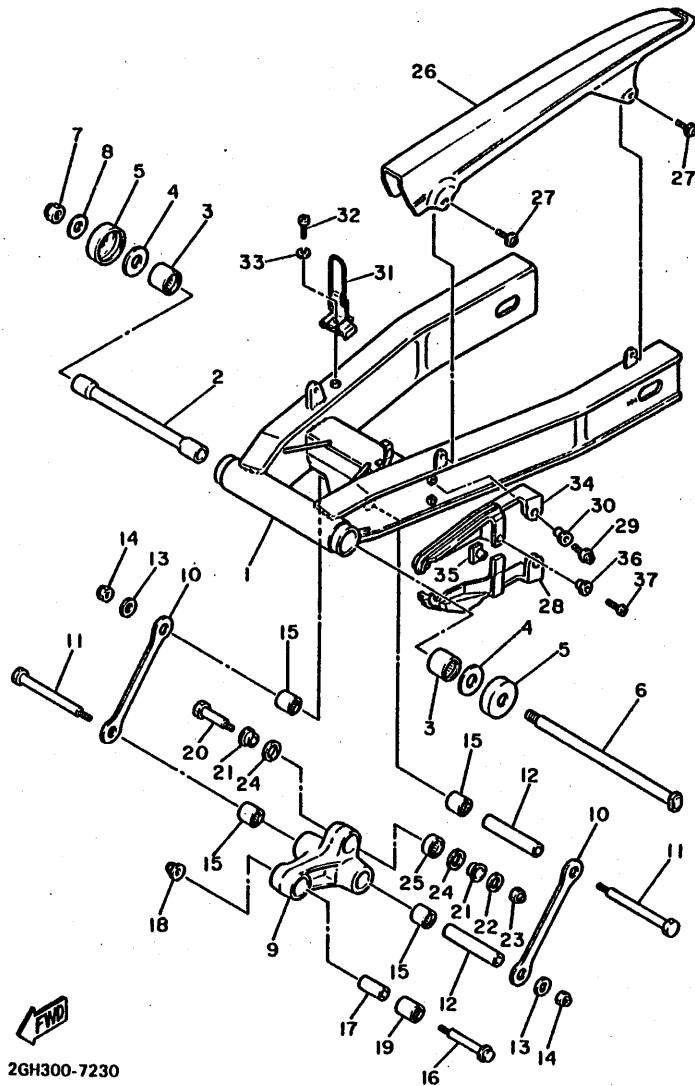

2GH300-7230

REF. NO.	PART NO.	DESCRIPTION	Q'TY	REMARKS
1	2GH-22110-00	REAR ARM COMP.	1	
2	36Y-22184-00	BUSH	1	
3	93317-42550	BEARING, cylindrical	2	
4	36Y-22127-00	SHIM	2	
5	36Y-22128-00	COVER, thrust 1	2	
6	2GH-22141-00	SHAFT, Pivot	1	
7	90185-14070	NUT, self-locking	1	
8	90201-14222	WASHER, Plate	1	
9	2KT-2217A-00	ARM, relay	1	
10	1WG-2217M-00	ARM 1	2	
11	90101-12673	BOLT	2	
12	90387-126T1	COLLAR	2	
13	90201-126A7	WASHER, Plate	2	
14	95611-12100	NUT, u	2	
15	93317-41761	BEARING, cylindrical	4	
16	90105-10454	BOLT, washer based	01	
17	90387-100T8	COLLAR	1	
18	95601-10200	NUT, self-locking	1	
19	93317-42060	BEARING, cylindrical	1	
20	90101-10659	BOLT	1	
21	90387-124L0	COLLAR	2	
22	90201-10437	WASHER, Plate	1	
23	95611-10100	NUT, u	1	
24	93101-16131	OIL SEAL	2	
25	93399-99919	BEARING	1	
26	2GH-22311-00	CASE, chain	1	
27	90159-06084	SCREW, with washer	2	
28	2GH-22151-20	SEAL, Guard	1	

D6

FIG. 23 REAR ARM

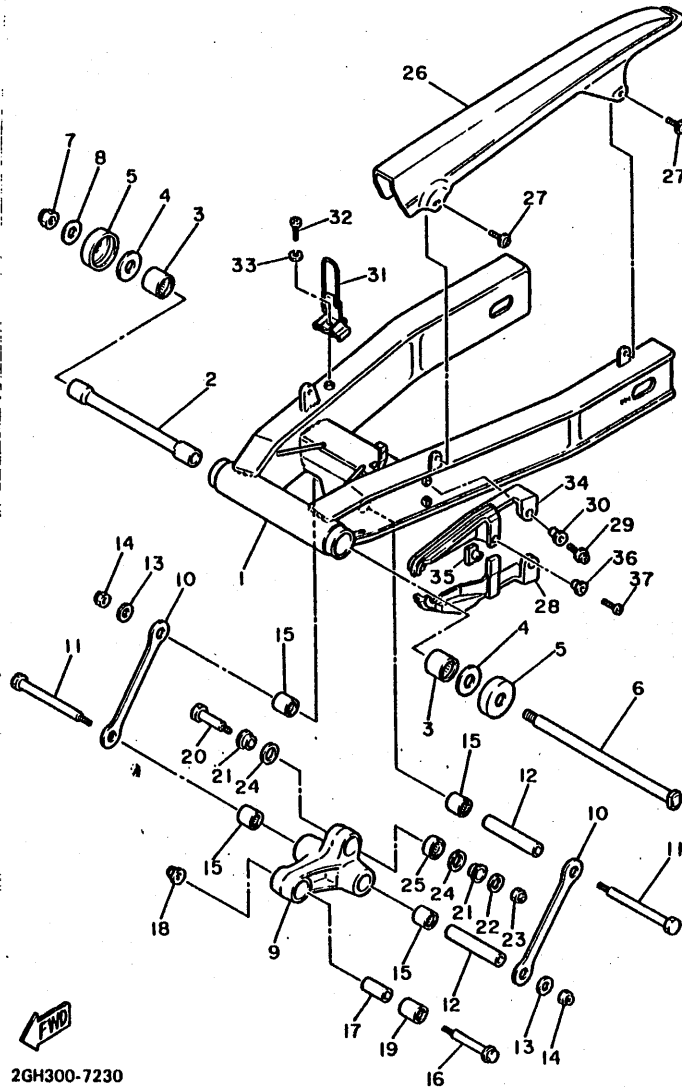

REF. NO.	PART NO.	DESCRIPTION	Q'TY	REMARKS
*29	90159-06108	SCREW, with washer	2	
30	90387-06704	COLLAR	2	
31	2GH-25875-50	HOLDER, brake hose 1	1	
32	92501-06020	SCREW, Pan head	1	
33	92990-06100	WASHER, sPrin8	1	
34	2GH-22152-20	SEAL, Guard	1	
35	31A-14477-00	PLATE	1	
36	90560-06244	SPACER	1	
37	92506-06012	SCREW, Pan head	2	



2GH300-7230

D7

FIG. 24 REAR SUSPENSION

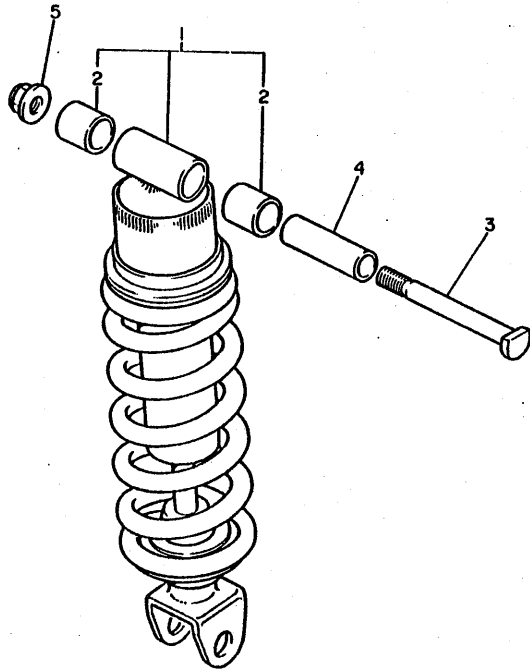

REF. NO.	PART NO.	DESCRIPTION	Q'TY	REMARKS
1	2GH-22210-00	SHOCK ABSORBER ASSY, rear	1	
2	90384-18157	BUSH, bimetal formed	2	
3	90109-103E7	BOLT	1	
4	90387-102T0	COLLAR	1	
5	95601-10200	NUT, self-locking	1	



2GH300-7240

D8

FIG. 25 STEERING

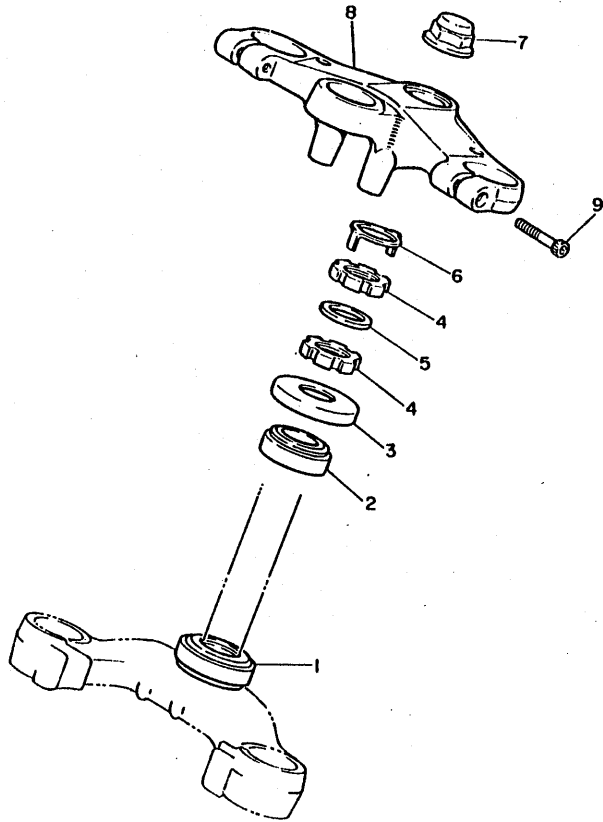

REF. NO.	PART NO.	DESCRIPTION	Q'TY	REMARKS
1	93332-00008	BEARING	1	
2	93332-00023	BEARING	1	
3	2GH-23415-00	COVER, ball race 1	1	
4	90179-25033	NUT	2	
5	90202-26142	WASHER, Plate	1	
6	26H-23418-01	WASHER, sPecial	1	
7	90176-22050	NUT, crown	1	
8	2GH-23435-00	CROWN, handle	1	
9	91316-08030	BOLT	2	



2GH300-7250

D9

FIG. 26 FRONT FORK

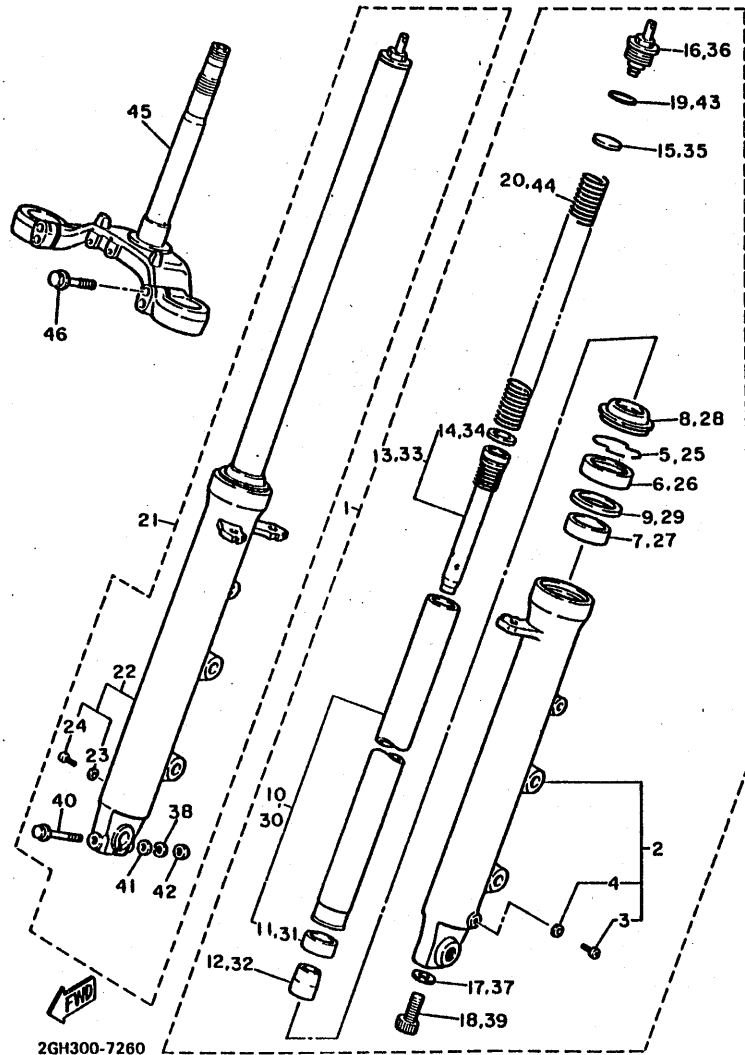

REF. NO.	PART NO.	DESCRIPTION	Q'TY	REMARKS
1	2GH-23102-00	FRONT FORK ASSY (L.H)	1	
2	2GH-23126-00-38	•TUBE, outer 1	1	clear buffing
3	4H7-23119-00	••PLUG, drain	1	
4	122-23129-00	••GASKET, drain Plug	1	
5	26H-23156-00	•CLIP, oil seal	1	
6	36Y-23145-00	•OIL SEAL	1	
7	36Y-23125-10	•METAL, slide 1	1	
8	36Y-23144-00	•SEAL, dust	1	
9	36Y-23146-10	•WASHER, oil seal	1	
10	2GH-23110-00	•INNER TUBE COMP.1	1	
11	36Y-23171-00	••PISTON, front fork	1	
12	2GH-23173-00	•SPINDLE, taPer	1	
13	2GH-23170-00	•CYLINDER COMP., front fork	1	
14	36Y-23157-00	••RING, Piston	1	
15	2GH-23149-00	•WASHER, sPring upper	1	
16	2GH-23111-00	•BOLT, caP	1	
17	4V4-23158-L0	•GASKET	1	
18	4V4-23181-L0	•BOLT, hexagon socket head	1	
19	36Y-23147-00	•O-RING	1	
20	2GH-23141-00	•SPRING, front fork	1	
21	2GH-23103-00	FRONT FORK ASSY (R.H)	1	
22	2GH-23136-00-38	•TUBE, outer 2	1	clear buffing
23	122-23129-00	••GASKET, drain Plug	1	
24	4H7-23119-00	••PLUG, drain	1	
25	26H-23156-00	•CLIP, oil seal	1	
26	36Y-23145-00	•OIL SEAL	1	
27	36Y-23125-10	•METAL, slide 1	1	
28	36Y-23144-00	•SEAL, dust	1	

FIG. 26 FRONT FORK

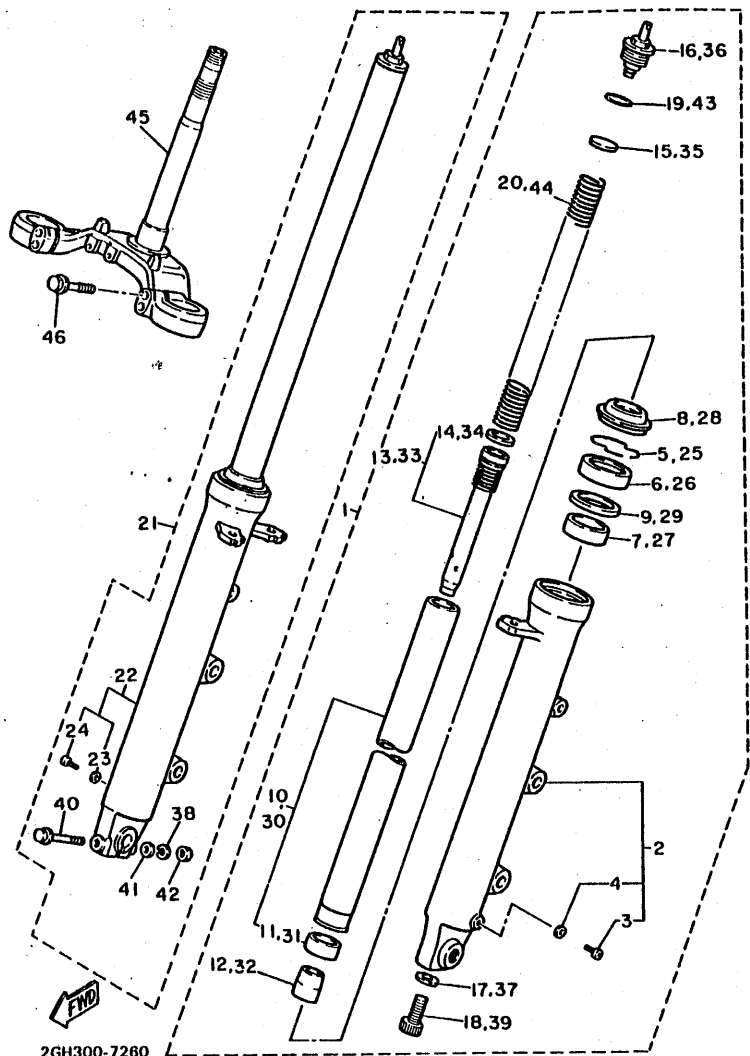

REF. NO.	PART NO.	DESCRIPTION	Q'TY	REMARKS
29	36Y-23146-10	.WASHER, oil seal	1	
30	2GH-23110-00	.INNER TUBE COMP.	1	
31	36Y-23171-00	..PISTON, front fork	1	
32	2GH-23173-00	.SPINDLE, taPer	1	
33	2GH-23170-00	.CYLINDER COMP., front fork	1	
34	36Y-23157-00	..RING, Piston	1	
35	2GH-23149-00	.WASHER, sPrinG upper	1	
36	2GH-23111-00	.BOLT, caP	1	
37	4V4-23158-L0	.GASKET	1	
38	92990-08100	.WASHER, sPrinG	1	
39	4V4-23181-L0	.BOLT, hexaGon socket head	1	
40	1UJ-23128-00	.BOLT, axle holder	1	
41	90201-08544	.WASHER, Plate	1	
42	95311-08600	.NUT	1	
43	36Y-23147-00	.O-RING	1	
44	2GH-23141-00	.SPRING, front fork	1	
45	2GH-23340-00	UNDER BRACKET COMP.	1	
46	1AE-23128-00	BOLT, axle holder	4	

FIG. 27 FUEL TANK

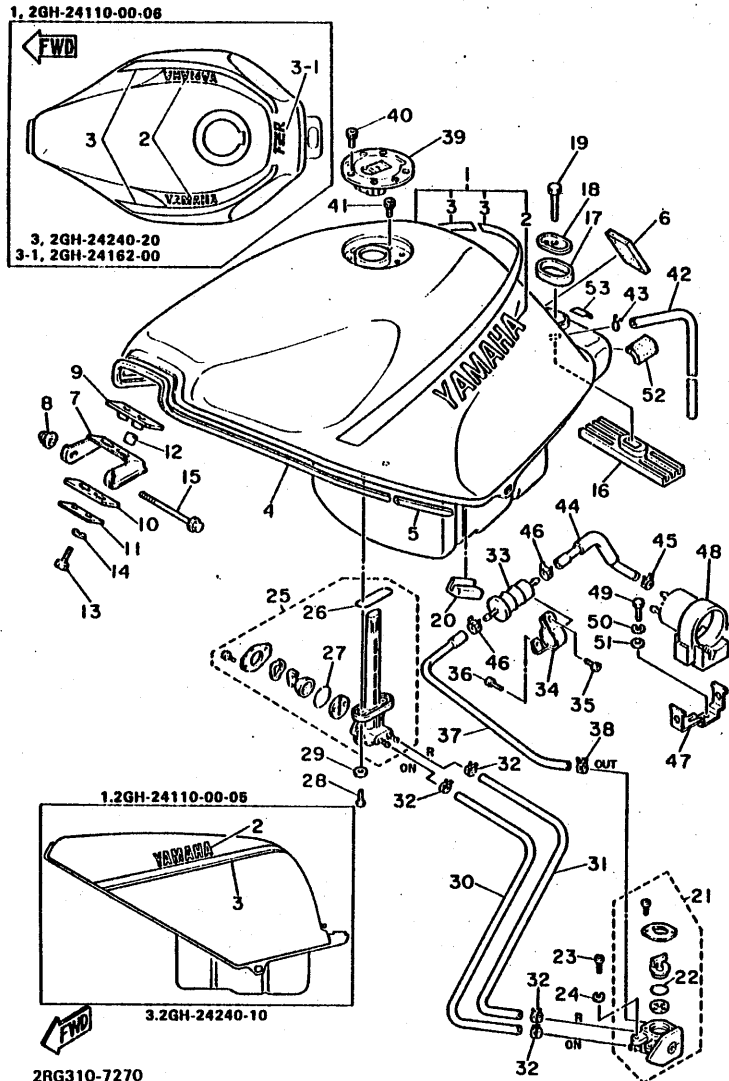

2RG310-7270

REF. NO.	PART NO.	DESCRIPTION	Q'TY	REMARKS
*1	2GH-24110-00-06	FUEL TANK COMP.	1	UR urushi black
	2GH-24110-00-04	FUEL TANK COMP.	1	UR atlantic blue/silky white
	2GH-24110-00-05	FUEL TANK COMP.	1	UR silky white-dynasty blue
*2	99224-00035	.EMBLEM, yamaha	2	UR for abl/sw/dyb
	99226-00030	.EMBLEM, yamaha	2	UR for urb
*3	2GH-24240-00	.GRAPHIC SET	1	UR for abl/sw
	2GH-24240-20	.GRAPHIC SET	1	UR for urb
	2GH-24240-10	.GRAPHIC SET	1	UR for sw/dyb
*3-1	2GH-24162-00	.EMBLEM 2	1	UR for urb
4	2GH-2834G-00	MOLE 5	1	
5	2GH-2834H-00	MOLE 6	2	
6	51L-28371-00	DAMPER	1	
7	2GH-24191-00	BRACKET, fuel tank 1	1	
8	95301-06800	NUT, crown	1	
9	2GH-24181-00	DAMPER, locating 1	1	
10	2GH-24183-00	DAMPER, locating 3	1	
11	2GH-24186-00	WASHER, special	1	
12	90387-06553	COLLAR	2	
13	97001-06025	BOLT	2	
14	92990-06100	WASHER, spring	2	
15	95811-06075	BOLT, flange	1	
16	2GH-24184-00	DAMPER, locating 4	1	
17	3Y6-24183-00	DAMPER, locating 3	1	
18	2GH-24187-00	WASHER, special	1	
19	97313-08030	BOLT	1	
20	2GH-24182-00	DAMPER, locating 2	2	
21	2GH-24500-00	FUEL COCK ASSY 1	1	
22	1JK-24534-00	.SEAL, cock	1	
23	92506-06012	SCREW, pan head	2	
24	92906-06100	WASHER, spring	2	
25	2GH-24510-00	FUEL COCK ASSY 2	1	
26	2W6-24512-00	.O-RING	1	

D12

FIG. 27 FUEL TANK

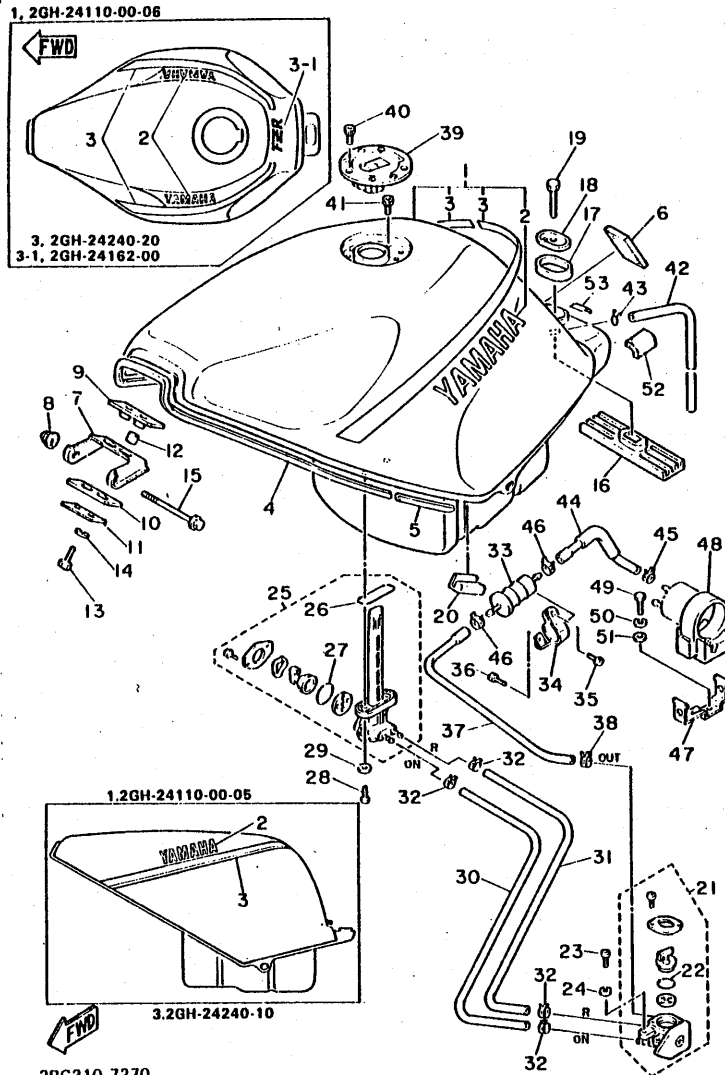

REF. NO.	PART NO.	DESCRIPTION	Q'TY	REMARKS
27	3H3-24534-00	O-RING	1	
28	90149-06011	SCREW	2	
29	90202-06010	WASHER, Plate	2	
30	90445-11698	HOSE	1	
31	90445-111F8	HOSE	1	
32	90467-10091	CLIP	4	
33	1FK-24560-00	FILTER ASSY	1	
34	2GH-24366-00	CLAMP, fuel Pipe 1	1	
35	98902-05012	SCREW, bind	1	
36	98903-06012	SCREW, bind	1	
37	2GH-24312-00	PIPE 2	1	
38	90467-10091	CLIP	1	
39	1JK-24602-11	CAP ASSY	1	
40	90110-05112	BOLT, hexagon socket head	3	
41	91311-05010	BOLT	1	
42	90445-10366	HOSE	1	
43	90467-09006	CLIP	1	
44	2GH-24313-00	PIPE 3	1	
45	90467-10091	CLIP	1	
46	90467-11044	CLIP	2	
47	2GH-24136-00	CLAMP 2	1	
48	2GH-24398-00	BAND 1	1	
49	97002-06016	BOLT	1	
50	92990-06100	WASHER, sPring	1	
51	92990-06600	WASHER, Plate	1	
*52	2GH-24185-00	DAMPER	2	
53	2GH-21732-00	SEAL 1	1	

D13

FIG. 29 FRONT WHEEL

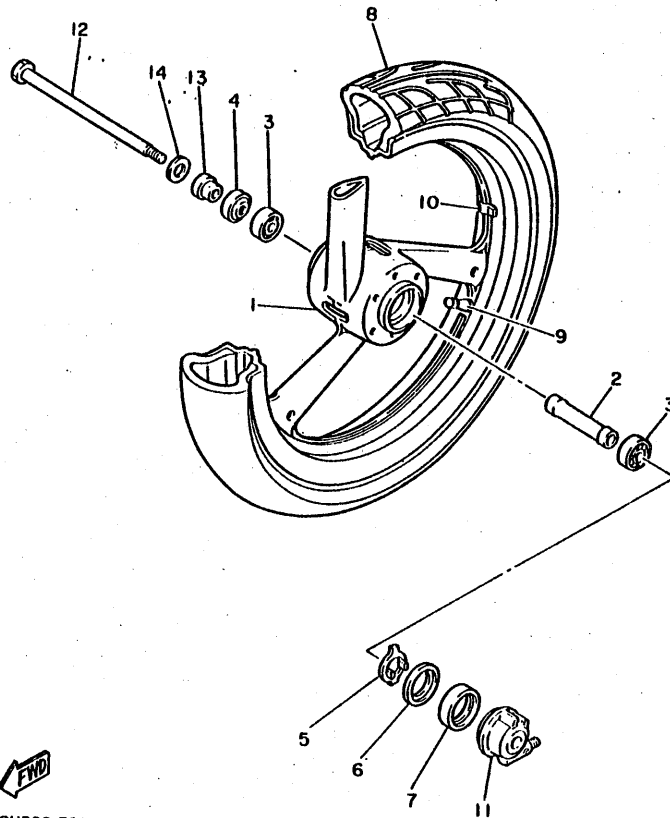

REF. NO.	PART NO.	DESCRIPTION	Q'TY	REMARKS
* 1	2GH-25168-00-UA	CAST WHEEL, front	1	UR castwheel white
	2GH-25168-00-WG	CAST WHEEL, front	1	UR hi tech silver
2	90560-15255	SPACER	1	
3	93306-30203	BEARING (B63022)	2	
4	93102-22014	OIL SEAL	1	
5	341-25149-00	CLUTCH, meter	1	
6	341-25846-00	RETAINER, clutch	1	
7	93105-45017	OIL SEAL	1	
8	*	TIRE (120/70 ZR17)	1	LM Pirelli
9	93900-00030	VALVE, rim	1	
10	29L-25398-00	BALANCER, wheel (10G)	1	UN
	29L-25398-10	BALANCER, wheel (20G)	1	UN
	29L-25398-20	BALANCER, wheel (30G)	1	UN
11	2GH-25190-00	GEAR UNIT ASSY	1	
12	47X-25181-00	AXLE, wheel	1	
13	90387-15550	COLLAR	1	
14	90201-15238	WASHER, Plate	1	



2GH300-7290

D15

FIG. 30 FRONT BRAKE CALIPER

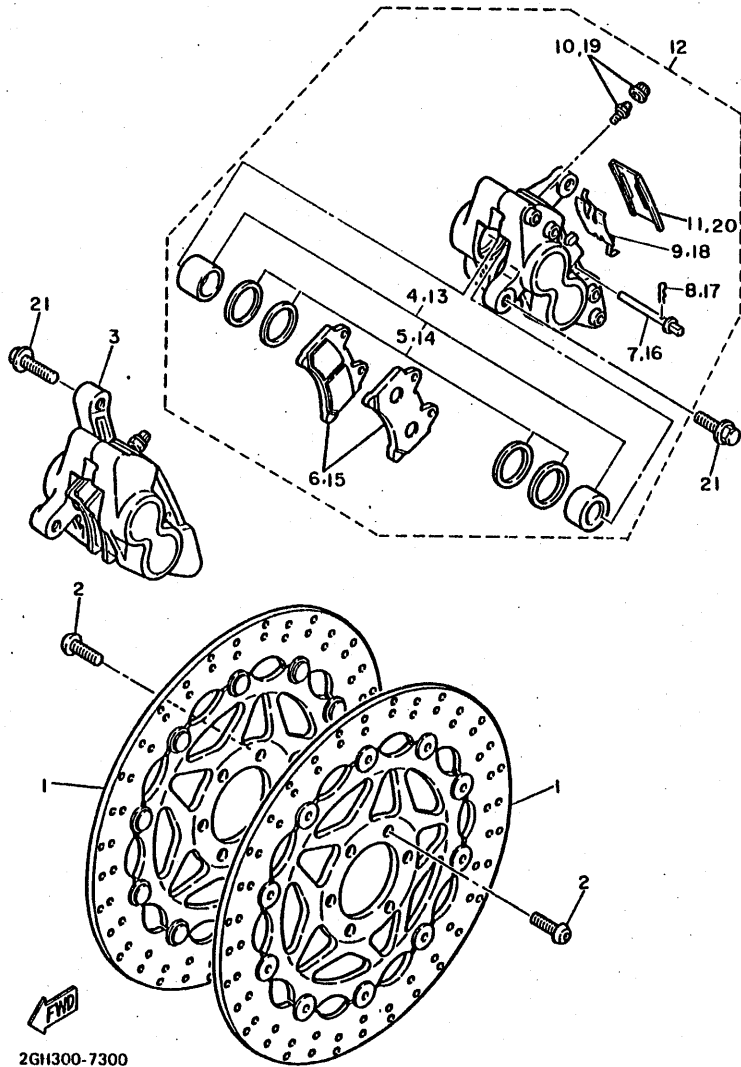

REF. NO.	PART NO.	DESCRIPTION	Q'TY	REMARKS
1	2GH-25830-00	DISK BRAKE ASSY	2	
2	90109-08718	BOLT	12	
3	2GH-25810-00	CALIPER ASSY (RIGHT)	1	
4	1NL-W0057-00	•PISTON ASSY, caliper	2	
5	1NL-W0047-00	••CALIPER SEAL KIT	1	
6	2GH-W0045-00	•BRAKE PAD KIT, front	1	
7	1KT-25924-00	•PIN, Pad	2	
8	1KT-25925-00	•CLIP	2	
9	2GH-25919-00	•SUPPORT, Pad	1	
10	26H-W0048-00	•BREED SCREW KIT	1	
11	1KT-25836-00	•COVER, dust	1	
12	2GH-25810-10	CALIPER ASSY (LEFT)	1	
13	1NL-W0057-00	•PISTON ASSY, caliper	2	
14	1NL-W0047-00	••CALIPER SEAL KIT	1	
15	2GH-W0045-00	•BRAKE PAD KIT, front	1	
16	1KT-25924-00	•PIN, Pad	2	
17	1KT-25925-00	•CLIP	2	
18	2GH-25919-00	•SUPPORT, Pad	1	
19	26H-W0048-00	•BREED SCREW KIT	1	
20	1KT-25836-00	•COVER, dust	1	
21	90105-10308	BOLT, washer based	4	

2GH300-7300

FIG. 31 REAR WHEEL

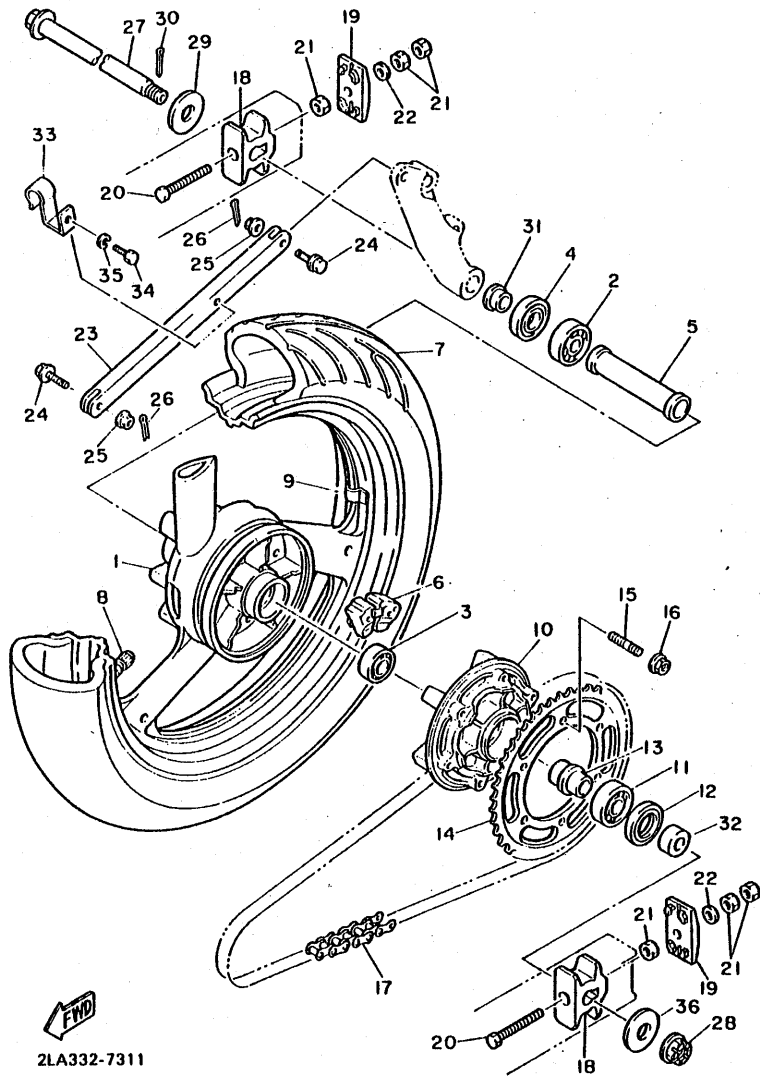

2LA332-7311

REF. NO.	PART NO.	DESCRIPTION	Q'TY	REMARKS
* 1	2GH-25338-00-UA	CAST WHEEL, rear	1	UR castwheel white
	2GH-25338-00-WG	CAST WHEEL, rear	1	UR hi tech silver
2	93306-30309	BEARING (B6303ZZ)	1	
3	93306-30306	BEARING (B6303)	1	
4	93102-25044	OIL SEAL	1	
5	90560-17260	SPACER	1	
6	2GH-25364-00	DAMPER	5	
7	*	TIRE (160/60 ZR18)	1	LM Pirelli
8	93900-00030	VALVE, rim	1	
9	29L-25398-00	BALANCER, wheel (10G)	1	UN
	29L-25398-10	BALANCER, wheel (20G)	1	UN
	29L-25398-20	BALANCER, wheel (30G)	1	UN
10	36Y-25366-01	CLUTCH, hub	1	
11	93306-30507	BEARING (B6305Z)	1	
12	93102-35065	OIL SEAL	1	
13	90387-171T5	COLLAR	1	
14	2GH-25446-20-33	SPROCKET, driven (46T)	1	yamaha black
15	90116-10485	BOLT, stud	6	
16	95601-10200	NUT, self-locking	6	
17	94580-99110	CHAIN(DID532ZL 110LE)	1	daido
18	2GH-25388-00	PULLER, chain 1	2	
19	2GH-25389-00	PULLER, chain 2	2	
20	90101-08647	BOLT	2	
21	95303-08600	NUT	6	
22	92901-08600	WASHER, plate	2	
23	1WG-25371-00	BAR, tension	1	
24	90105-08321	BOLT, washer based	2	
25	95701-08500	NUT, flange	2	
26	91401-20015	PIN, cotter	2	

FIG. 31 REAR WHEEL

REF. NO.	PART NO.	DESCRIPTION	Q'TY	REMARKS
27	2GH-25381-00	AXLE, wheel	1	
28	90171-16024	NUT, castle	1	
*29	90201-177K7	WASHER, Plate	1	
30	91401-30030	PIN, cotter	1	
31	90387-170J6	COLLAR	1	
32	90387-171T6	COLLAR	1	
33	2GH-25876-00	HOLDER, brake hose 2	1	
34	97301-06010	BOLT	1	
35	92990-06100	WASHER, sPrin8	1	
*36	90201-165L8	WASHER, Plate	1	

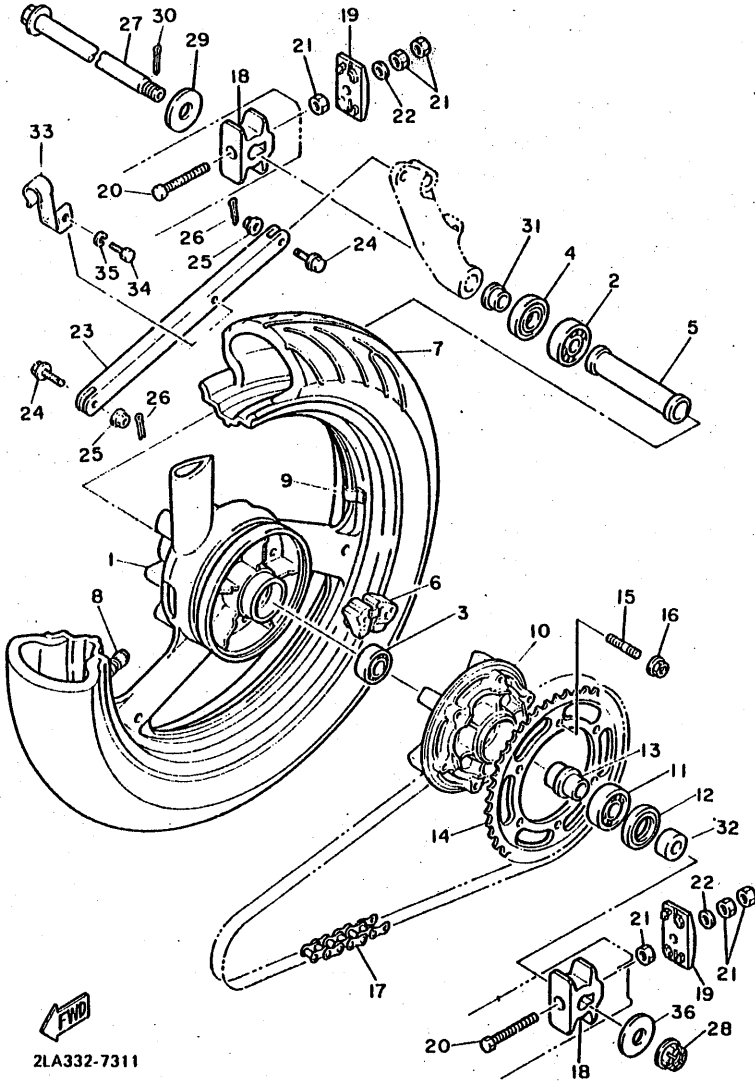

2LA332-7311

FIG. 32 REAR BRAKE CALIPER

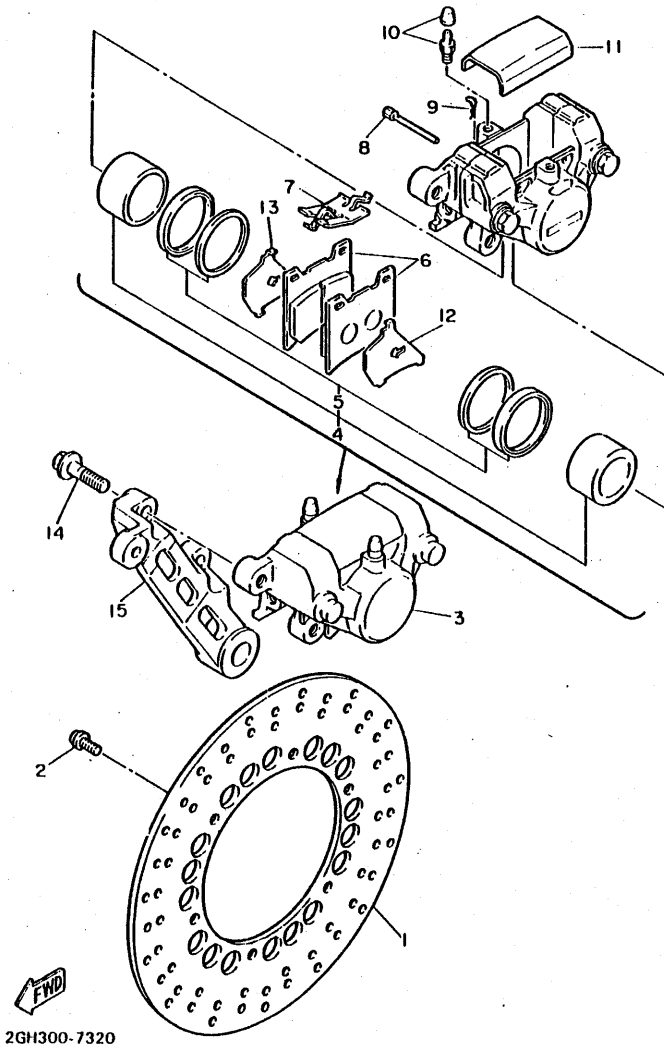

REF. NO.	PART NO.	DESCRIPTION	Q'TY	REMARKS
1	2KT-25831-00	DISC, brake (RIGHT)	1	
2	90109-08718	BOLT	6	
3	2KT-25810-50	CALIPER ASSY	1	
4	31A-W0057-00	.PISTON ASSY, caliPer	1	
5	31A-W0047-00	..CALIPER SEAL KIT	1	
6	47X-W0045-00	.BRAKE PAD KIT, front	1	
7	29L-25919-00	.SUPPORT, Pad	1	
8	26H-25924-00	.PIN, Pad	2	
9	26H-25925-00	.CLIP	2	
10	26H-W0048-00	.BREED SCREW KIT	2	
11	51J-25836-00	.COVER, dust	1	
12	1FK-25827-00	.SHIM, caliPer	1	
13	1FK-25828-00	.SHIM, caliPer	1	
14	90105-10308	BOLT, washer based	2	
15	1AE-25819-50	BRACKET, caliPer	1	

FIG. 33 STEERING HANDLE. CABLE

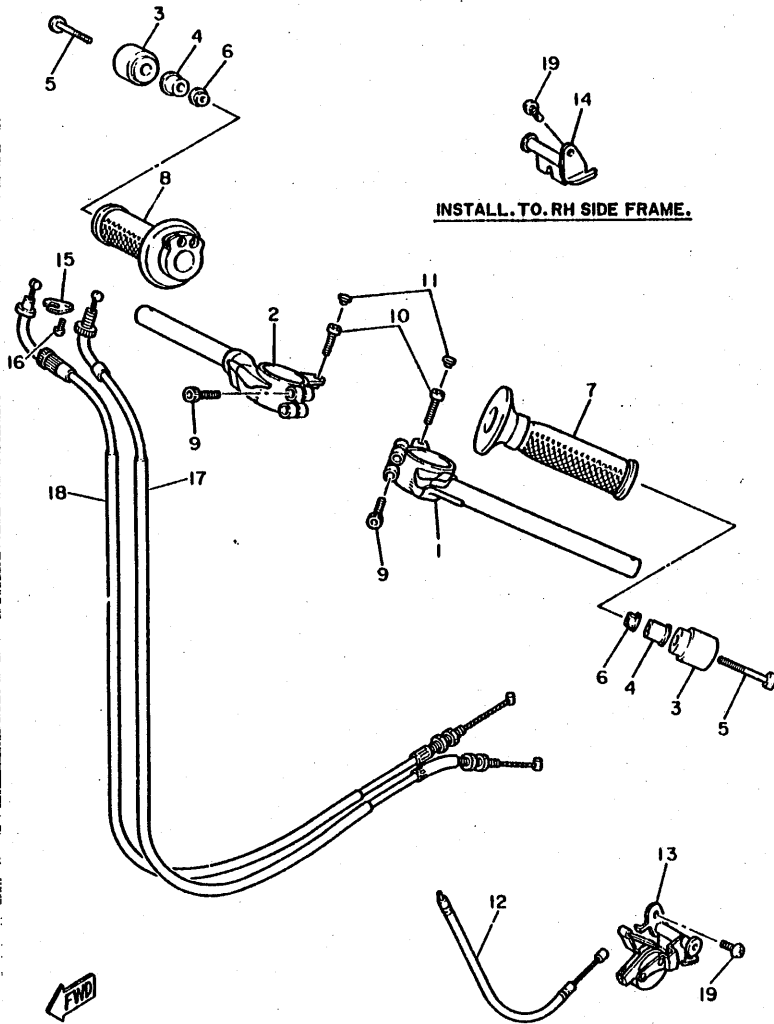

REF. NO.	PART NO.	DESCRIPTION	Q'TY	REMARKS
1	2GH-26121-00	HANDLEBAR (LEFT)	1	
2	2GH-26122-00	HANDLEBAR (RIGHT)	1	
3	2GH-26246-10	END, grip	2	
4	2GH-2622F-00	DAMPER, locatin& 1	2	
5	91316-06070	BOLT	2	
6	95701-06500	NUT, flange	2	
7	47X-26241-00	GRIP (L.H)	1	
8	47X-26240-00	GRIP ASSY	1	
9	91316-08030	BOLT	4	
10	90110-06157	BOLT, hexagon socket head	2	
11	10L-23469-00	CAP, bolt	2	
12	2GH-26331-00	CABLE, starter 1	1	
13	2GH-83940-00	STARTER ASSY	1	
14	2GH-2832U-00	STAY, side 1	1	
15	5H0-26393-00	HOLDER	1	
16	98506-05008	SCREW, Pan head	1	
*17	2GH-26312-01	CABLE, throttle 2	1	
*18	2GH-26311-01	CABLE, throttle 1	1	
19	92016-06020	SCREW	2	



2GH300-7330

FIG. 34 FRONT MASTER CYLINDER

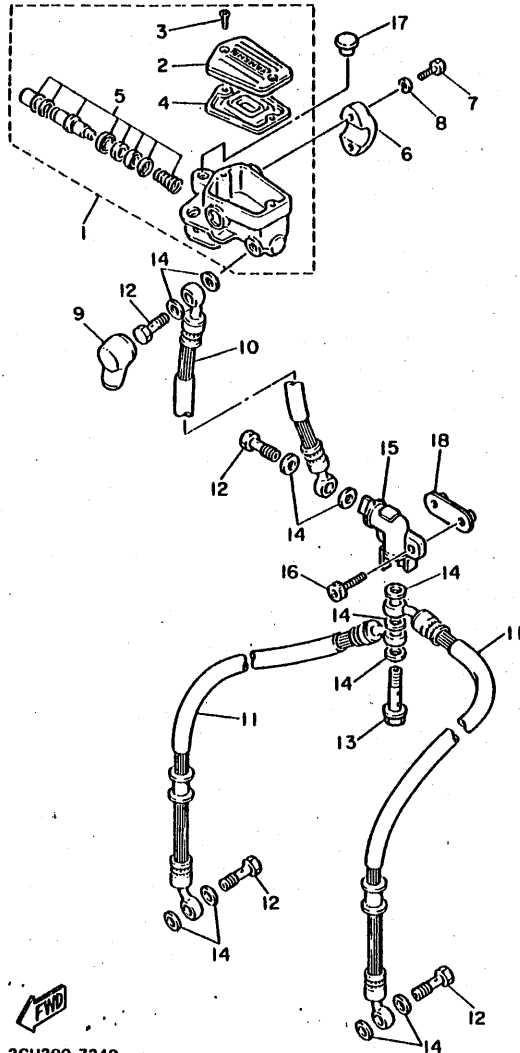

2GH300-7340

E7

REF. NO.	PART NO.	DESCRIPTION	Q'TY	REMARKS
* 1	36Y-25850-01	MASTER CYLINDER ASSY	1	
* 2	36Y-25852-01	.CAP, reservoir	1	
3	98706-04012	.SCREW, flat head	2	
4	36Y-25854-00	.DIAPHRAGM, reservoir	1	
5	36Y-W0041-00	.CYLINDER KIT, master	1	
6	36Y-25867-00	BRACKET, master cylinder	1	
7	91316-06025	BOLT	2	
8	92906-06100	WASHER, spring	2	
9	4L0-25862-00	BOOT, master cylinder	1	
10	2GH-25872-00	HOSE, brake 1	1	
11	2GH-25873-00	HOSE, brake 2	2	
12	90401-10096	BOLT, union	4	
13	90401-10095	BOLT, union	1	
14	90201-10118	WASHER, Plate	11	
15	11U-25885-00	JOINT	1	
16	91316-06030	BOLT	2	
17	90338-09012	PLUG	1	
18	2GH-2612E-00	BRACKET	1	

FIG. 35 FRONT MASTER CYLINDER 2

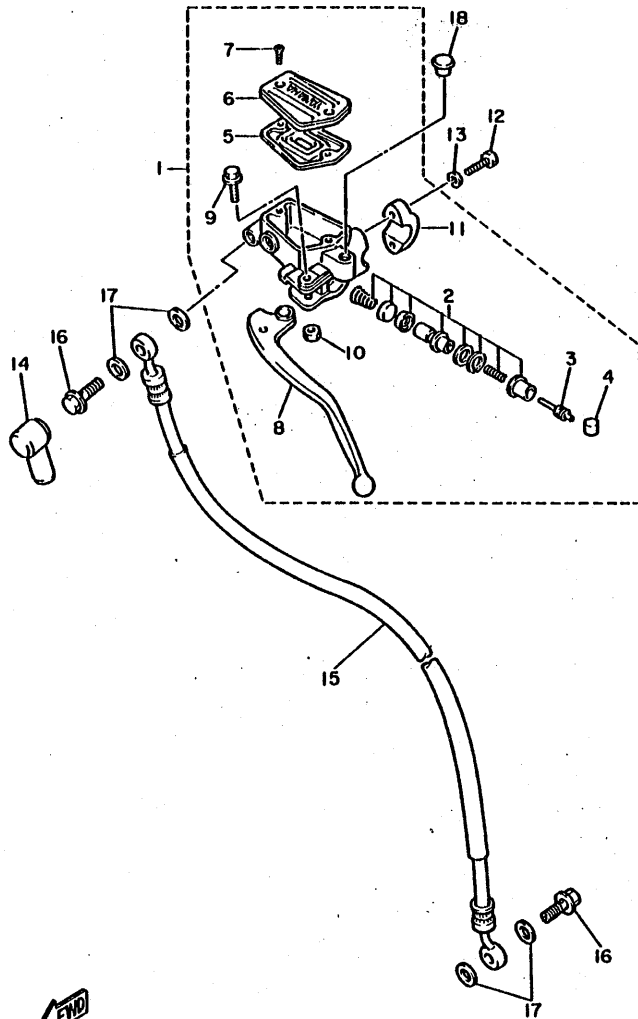

REF. NO.	PART NO.	DESCRIPTION	Q'TY	REMARKS
* 1	3BV-26450-00	MASTER CYLINDER ASSY (CLUTCH)	1	
2	26H-W0099-00	.CYLINDER KIT, master (CLUTCH)	1	
3	26H-26464-00	.ROD, Push	1	
4	26H-26455-00	.BUSH	1	
5	1AE-26454-00	.DIAPHRAGM, reservoir.	1	
* 6	1FK-26452-01	.CAP, reservoir	1	
7	98706-04012	.SCREW, flat head	2	
8	1AE-83912-00	.LEVER 1	1	
9	90109-067A0	.BOLT	1	
10	95606-06100	.NUT, u	1	
11	1AE-26467-00	.HOLDER	1	
12	91316-06025	BOLT	2	
13	92906-06100	WASHER, spring	2	
14	4L0-25862-00	BOOT, master cylinder	1	
15	2GH-26470-00	HOSE, clutch	1	
16	90401-10096	BOLT, union	2	
17	90201-10118	WASHER, Plate	4	
18	90338-09012	PLUG	1	



2GH300-7350

E8

FIG. 36 STAND. FOOTREST

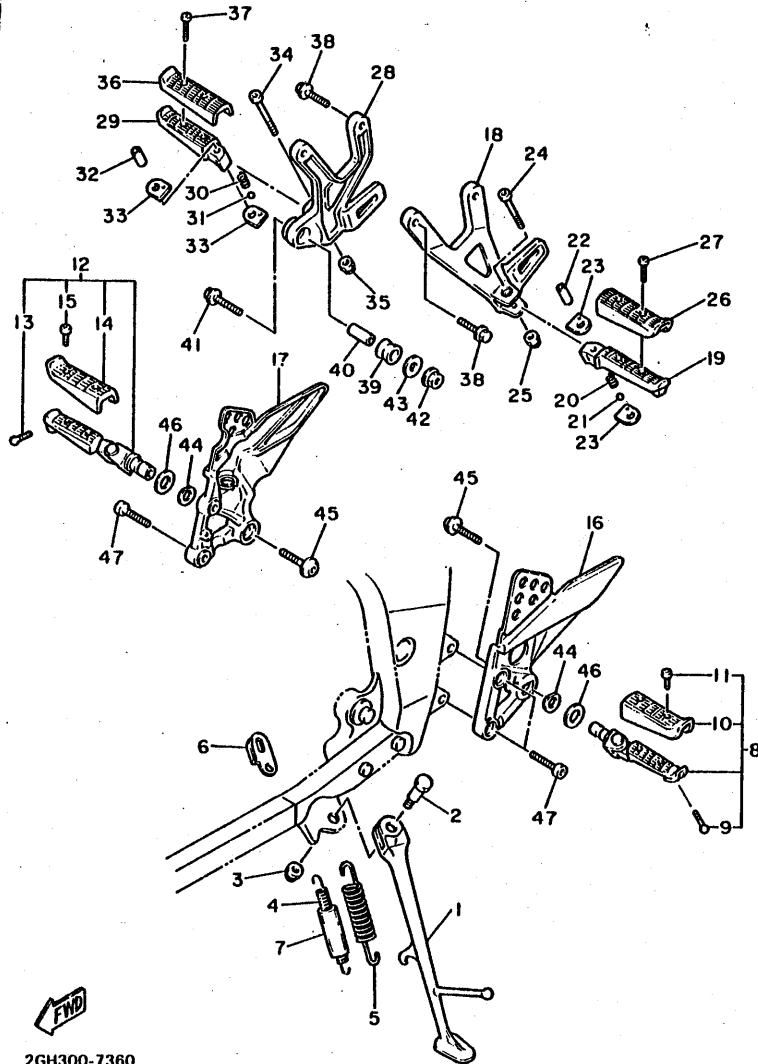

2GH300-7360

REF. NO.	PART NO.	DESCRIPTION	Q'TY	REMARKS
1	2GH-27311-00	STAND, side	1	
2	90109-104E6	BOLT	1	
3	90185-10037	NUT, self-locking	1	
4	90506-18224	SPRING, tension	1	
5	90506-26225	SPRING, tension	1	
6	2KT-27315-00	LINK, side stand	1	
7	1TX-27351-00	GUIDE, side stand	1	
8	2GH-27410-00	FRONT FOOTREST ASSY (LEFT)	1	
9	90109-083E2	.BOLT	1	
10	2GH-27413-00	.COVER, footrest	1	
11	90157-05079	.SCREW, Pan head	2	
12	2GH-27420-00	FRONT FOOTREST ASSY (RIGHT)	1	
13	90109-083E2	.BOLT	1	
14	2GH-27413-00	.COVER, footrest	1	
15	90157-05079	.SCREW, Pan head	2	
16	2GH-27442-00	BRACKET 2	1	
17	2GH-27443-00	BRACKET 3	1	
18	2GH-2741L-00	BRACKET 4	1	
19	2GH-27431-00	FOOTREST, rear 1	1	
20	90501-12743	SPRING, compression	1	
21	93501-04011	BALL	1	
22	90387-061G0	COLLAR	1	
23	1HX-27437-00	WASHER, special	2	
24	91311-06045	BOLT	1	
25	95601-06100	NUT, u	1	
26	2GH-27413-00	COVER, footrest	1	
27	90157-05079	SCREW, Pan head	2	
28	2GH-2742L-00	BRACKET 5	1	

FIG. 36 STAND, FOOTREST

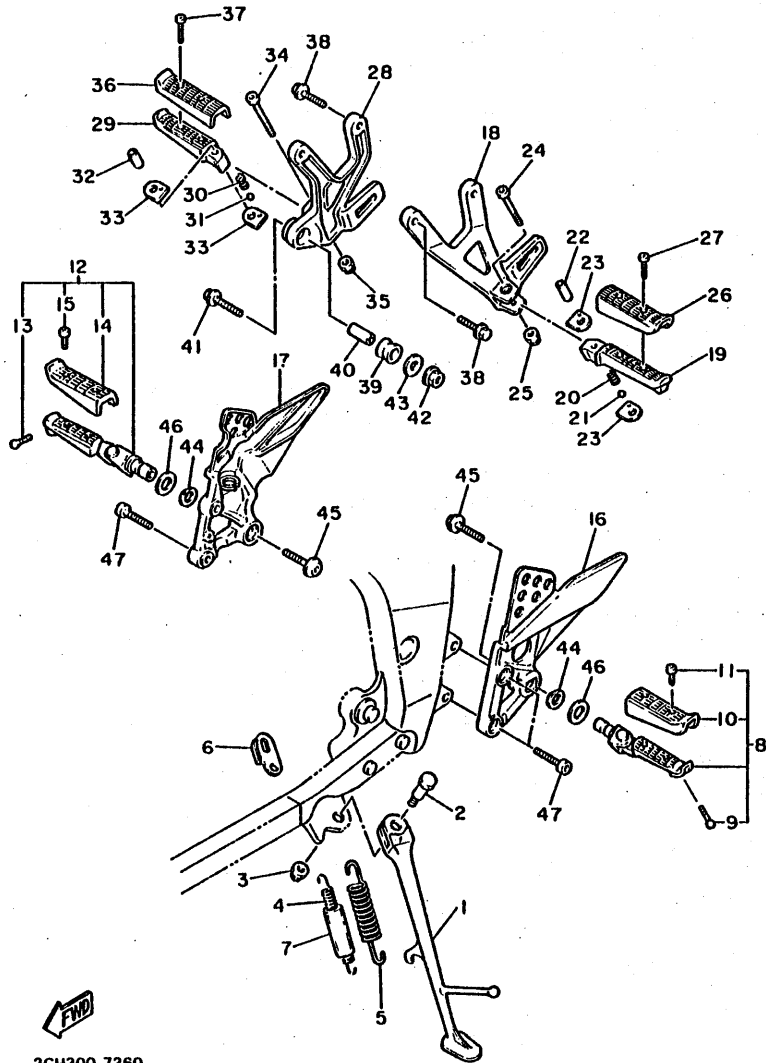

REF. NO.	PART NO.	DESCRIPTION	Q'TY	REMARKS
29	2GH-27441-00	FOOTREST, rear 2	1	
30	90501-12743	SPRING, compression	1	
31	93501-04011	BALL	1	
32	90387-06160	COLLAR	1	
33	1HX-27437-00	WASHER, special	2	
34	91311-06045	BOLT	1	
35	95601-06100	NUT, u	1	
36	2GH-27413-00	COVER, footrest	1	
37	90157-05079	SCREW, Pan head	2	
38	95021-08025	BOLT, flange	4	
39	2H7-27414-00	DAMPER, footrest	1	
40	90387-10636	COLLAR	1	
41	90105-10316	BOLT, washer based	1	
42	95701-10500	NUT, flange	1	
43	90201-10669	WASHER, plate	1	
44	90214-10047	WASHER, claw	2	
45	90109-103A9	BOLT	2	
46	90206-17084	WASHER, wave	2	
47	90110-08066	BOLT, hexagon socket head	4	

2GH300-7360

FIG. 37 REAR MASTER CYLINDER

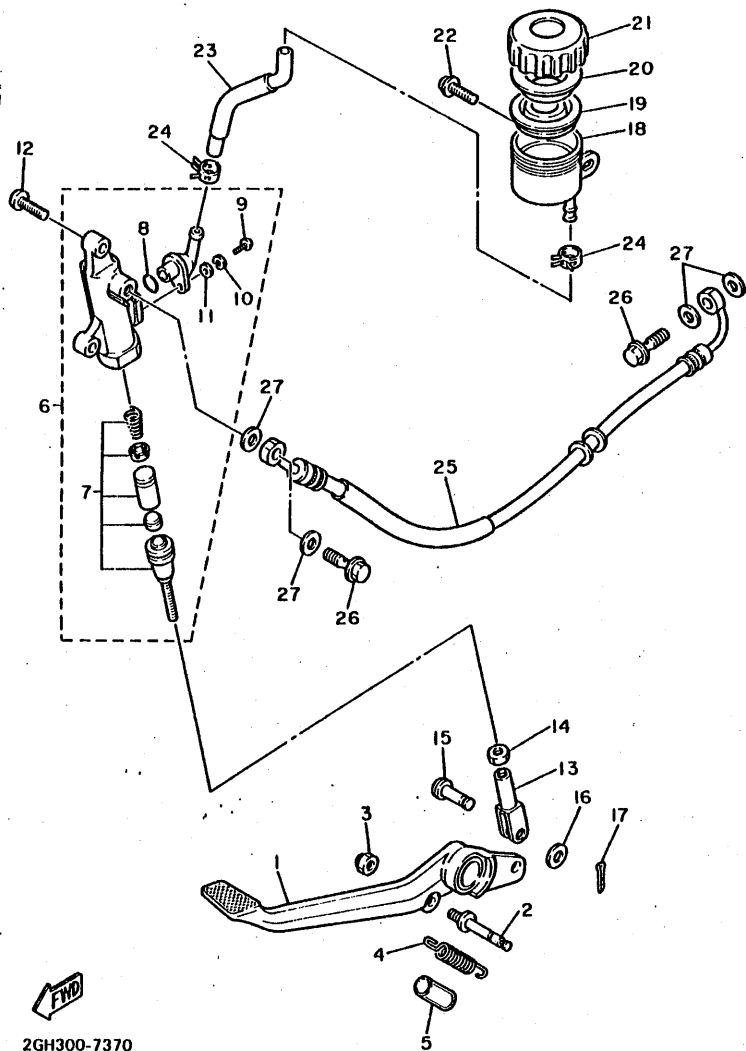

2GH300-7370

REF. NO.	PART NO.	DESCRIPTION	Q'TY	REMARKS
1	2GH-27211-00	PEDAL, brake	1	
2	1KT-27813-00	PIN, Pedal crank	1	
3	95601-08100	NUT, u	1	
4	90508-20737	SPRING, torsion	1	
5	90446-17267	HOSE	1	
6	2GH-25850-50	MASTER CYLINDER ASSY	1	
7	2GH-W0042-50	•CYLINDER KIT, master	1	
8	93210-15620	•O-RING	1	
9	98506-04012	•SCREW, Pan head	1	
10	92906-04100	•WASHER, sPrin&	1	
11	92906-04600	•WASHER, Plate	1	
12	92016-08030	SCREW	2	
13	31A-27222-00	JOINT	1	
14	95303-08700	NUT	1	
15	90240-08013	PIN, clevis	1	
16	90201-08083	WASHER, Plate	1	
17	91401-20015	PIN, cotter	1	
18	31A-25894-01	TANK, reservoir	1	
19	360-25854-00	DIAPHRAGM, reservoir	1	
*20	2GU-25855-00	BUSH, diaPhra&m	1	
*21	2GU-25852-50	CAP, reservoir	1	
22	90159-06085	SCREW, with washer	1	
23	2GH-25895-00	HOSE, reservoir	1	
24	90467-14057	CLIP	2	
25	2GH-25872-50	HOSE, brake 1	1	
26	90401-10096	BOLT, union	2	
27	90201-10118	WASHER, Plate	4	

FIG. 38 COWLING 1

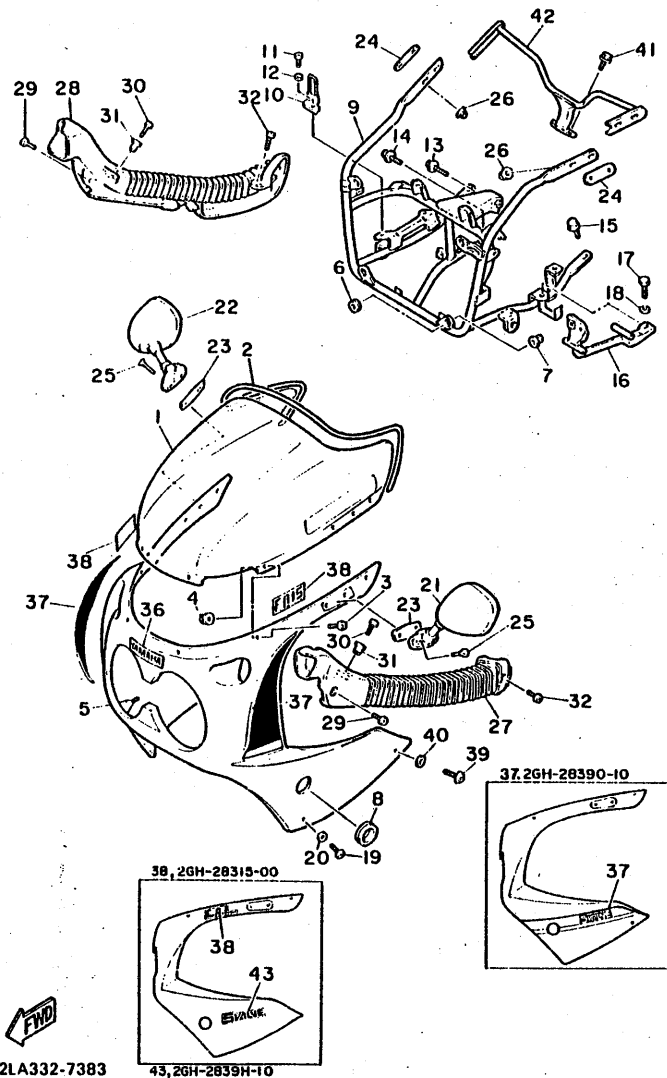

2LA332-7383

43, 2GH-2839H-10

REF. NO.	PART NO.	DESCRIPTION	Q'TY	REMARKS
1	2LJ-28381-00	WINDSHIELD	1	
2	36Y-28348-00	MOLE 4	1	
3	90150-05020	SCREW, round head	6	
4	95706-05500	NUT, flange	6	
*5	2GH-2835G-00-GE	BODY, front upper 1	1	UR silky white
	2GH-2835G-00-JW	BODY, front upper 1	1	UR urushi black
6	90480-14229	GROMMET	4	
7	90179-06500	NUT	4	
8	90480-35394	GROMMET	2	
9	2GH-28356-00	STAY 1	1	
10	2GH-2834V-00	PROTECTOR 1	1	
11	92506-06012	SCREW, pan head	1	
12	92906-06600	WASHER, plate	1	
13	95026-08040	BOLT, flange	1	
14	95026-08025	BOLT, flange	1	
15	95826-06012	BOLT, flange	2	
16	2GH-21238-00	BRACKET	1	
17	97006-06012	BOLT	2	
18	92906-06100	WASHER, spring	2	
19	90110-05079	BOLT, hexagon socket head	2	
20	90202-05180	WASHER, plate	2	
*21	2LL-26280-00	BACK MIRROR ASSY (LEFT)	1	UR for oceania
	2LL-26280-10	BACK MIRROR ASSY (LEFT)	1	UR for oceania (for urb)
	2GH-26280-00	BACK MIRROR ASSY (LEFT)	1	UR for s-africa
	2GH-26280-10	BACK MIRROR ASSY (LEFT)	1	UR for s-africa (for urb)
*22	2LL-26290-00	BACK MIRROR ASSY (RIGHT)	1	UR for oceania
	2LL-26290-10	BACK MIRROR ASSY (RIGHT)	1	UR for oceania (for urb)
	2GH-26290-10	BACK MIRROR ASSY (RIGHT)	1	UR for s-africa (for urb)
	2GH-26290-00	BACK MIRROR ASSY (RIGHT)	1	UR for s-africa
23	1AE-26298-00	PLATE, mirror fitting 1	2	

FIG. 38 COWLING 1

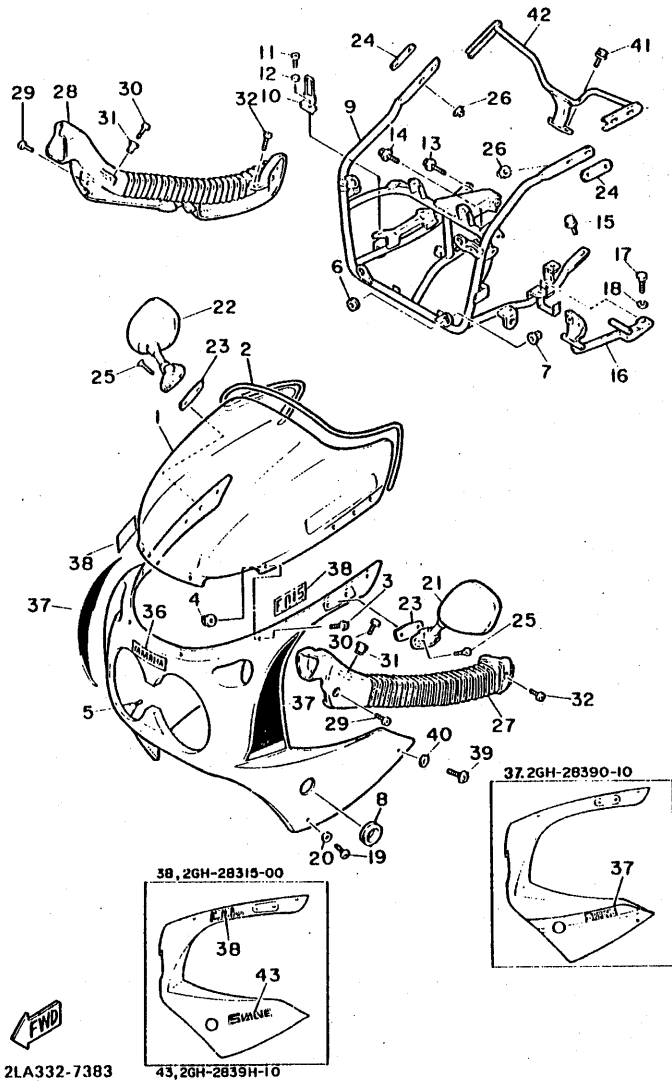

REF. NO.	PART NO.	DESCRIPTION	Q'TY	REMARKS
24	1AE-26299-00	PLATE, mirror fitting 2	2	
25	92706-06030	SCREW, flat head	4	
26	90176-06055	NUT, crown	4	
27	2GH-2838N-00	DUCT 1	1	
28	2GH-2838R-00	DUCT 2	1	
29	90154-06046	SCREW, binding	2	
30	90149-06184	SCREW	2	
*31	90387-060A7	COLLAR	2	
32	90154-06043	SCREW, binding	4	
*36	99234-00020	EMBLEM, yamaha	1	UR for sw/frd, sw/dyb
	99236-00025	EMBLEM, yamaha	1	UR for urb
37	2GH-28390-00	GRAPHIC SET, cowling	1	UR for sw/frd
	2GH-28390-10	GRAPHIC SET, cowling	1	UR for sw/dyb
*38	2KR-28368-00	EMBLEM	2	UR for sw/frd, sw/dyb
	2GH-28315-00	EMBLEM	2	UR for urb
39	90149-06243	SCREW	2	
40	90202-07015	WASHER, plate	2	
41	95026-06012	BOLT, flange	2	
42	2GH-2831W-00	STAY, mirror 1	1	
*43	2GH-2839H-10	EMBLEM 1	2	for urb

FIG. 38-1 COWLING 2

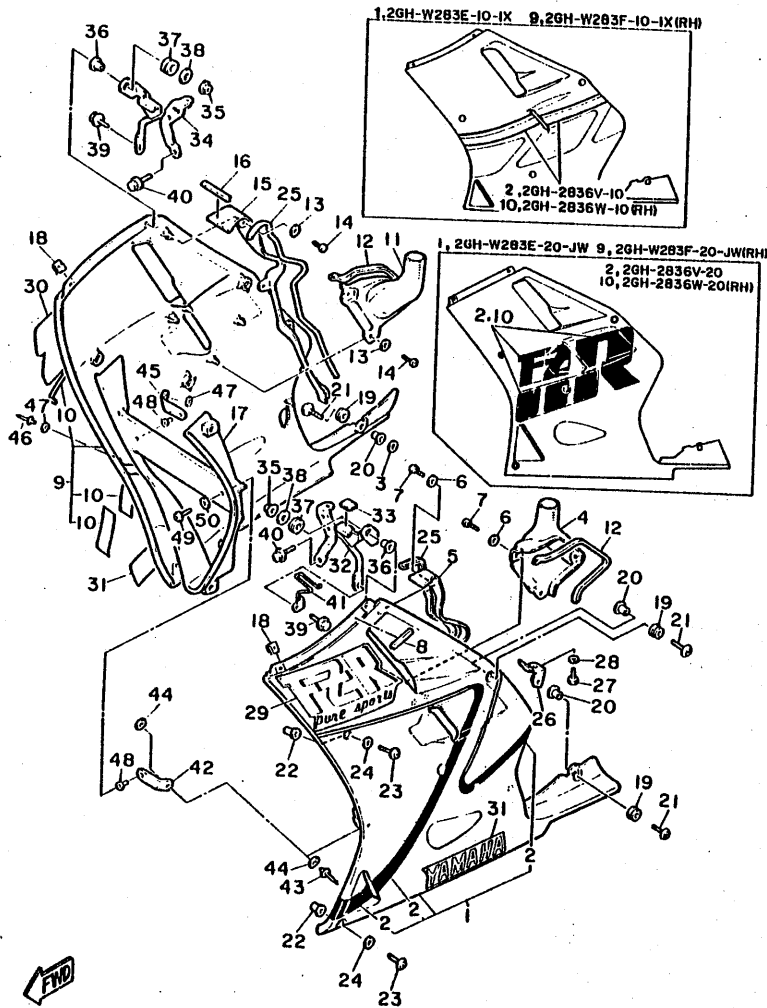

REF. NO.	PART NO.	DESCRIPTION	Q'TY	REMARKS
*1	2GH-W283E-20-JW	BODY, front lower 1	1	UR urushi black
	2GH-W283E-00-0X	BODY, front lower 1	1	UR silky white / fine red
	2GH-W283E-10-1X	BODY, front lower 1	1	UR silky white / dynasty blue
*2	2GH-2836V-00	.GRAPHIC SET 3, cowling	1	UR for sw / lrd
	2GH-2836V-10	.GRAPHIC SET3, cowling	1	UR for sw / dyb
	2GH-2836V-20	.GRAPHIC SET3, cowling	1	UR for urb
3	90201-062J7	WASHER, plate	1	
4	2GH-2838T-00	DUCT 3	1	
5	2GH-28396-00	PLATE 1	1	
6	92906-05200	WASHER, plain	6	
7	97706-50614	SCREW, tapping	6	
8	1JK-21652-00	PROTECTOR	1	
*9	2GH-W283F-20-JW	BODY, front lower 2	1	UR urushi black
	2GH-W283F-00-0X	BODY, front lower 2	1	UR silky white / fine red
	2GH-W283F-10-1X	BODY, front lower 2	1	UR silky white / dynasty blue
*10	2GH-2836W-00	.GRAPHIC SET 4, cowling	1	UR for sw / lrd
	2GH-2836W-10	.GRAPHIC SET 4, cowling	1	UR for sw / dyb
	2GH-2836W-20	.GRAPHIC SET 4, cowling	1	UR for urb
11	2GH-2838U-00	DUCT 4	1	
12	2GH-28347-00	MOLE 3	2	
13	92906-05200	WASHER, plain	6	
14	97706-50614	SCREW, tapping	6	
15	2GH-28397-00	PLATE 2	1	
16	2GH-28345-00	MOLE 1	1	
*17	2GH-2836K-00-GE	PANEL, inner 1	1	UR silky white
	2GH-2836K-00-JW	PANEL, inner 1	1	UR urushi black
18	90183-05024	NUT, spring	2	
19	90480-13398	GROMMET	6	
20	90387-067N5	COLLAR	6	
21	90110-06083	BOLT, hexagon socket head	6	



2LA332-7384

E14

FIG. 38-1 COWLING 2

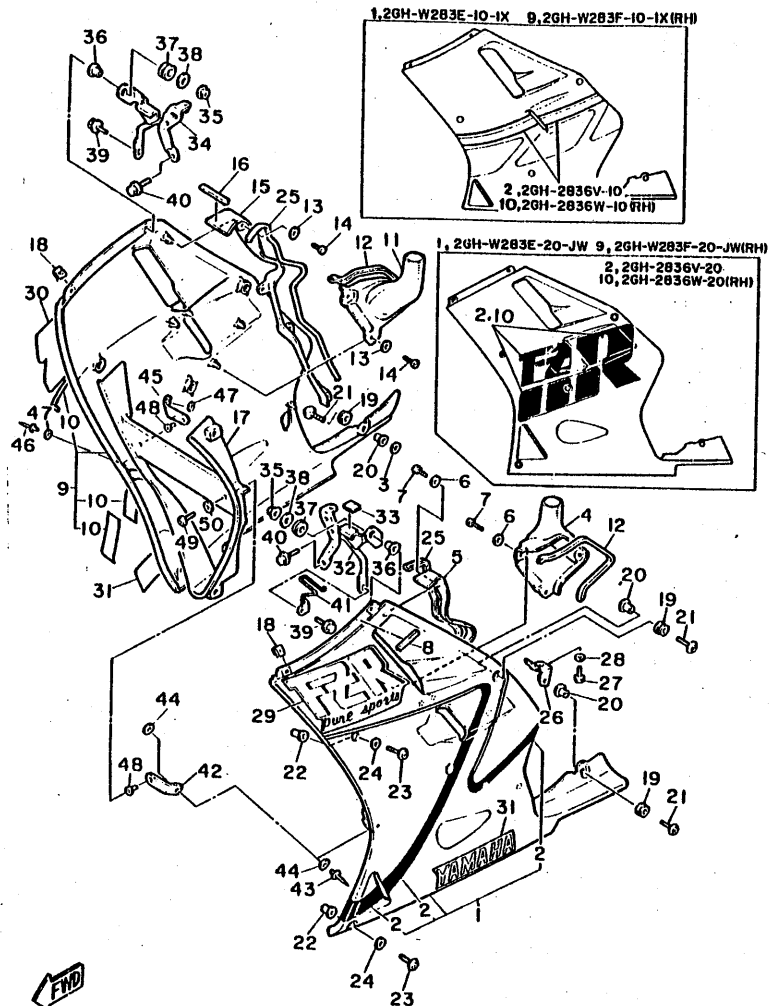

2LA332-7384

REF. NO.	PART NO.	DESCRIPTION	Q'TY	REMARKS
22	90179-05271	NUT	4	
23	90149-05244	SCREW	4	
24	90202-05180	WASHER, plate	4	
25	2GH-28346-00	MOLE 2	2	
26	2GH-2836F-00	BRACKET 3	1	
27	97301-06010	BOLT	1	
28	92990-06100	WASHER, spring	1	
29	2GH-28328-00	EMBLEM	1	UR for sw/lrd
	2GH-28328-10	EMBLEM	1	UR for sw/dyb
30	2GH-28368-00	EMBLEM	1	UR for sw/lrd
	2GH-28368-10	EMBLEM	1	UR for sw/dyb
*31	99234-00070	EMBLEM, yamaha	2	UR for sw/lrd, sw/dyb
	99232-00070	EMBLEM, yamaha	2	UR for urb
*32	2GH-28321-01	STAY, leg shield (LEFT)	1	
33	2H7-21628-00	DAMPER, mud guard	1	
34	2GH-28322-00	STAY, leg shield (RIGHT)	1	
35	95706-06500	NUT, flange	2	
36	90387-071E0	COLLAR	2	
37	90480-14323	GROMMET	2	
38	90201-06059	WASHER, plate	2	
39	95806-06016	BOLT, flange	2	
40	95026-06012	BOLT, flange	2	
41	2GH-21362-00	HOLDER, high tension cord	1	
42	2GH-2833F-00	BRACKET 9	1	
*43	90267-40029	RIVET, blind	1	
*44	90201-047A2	WASHER, plate	2	
45	2GH-2833G-00	BRACKET 10	1	
46	90267-40029	RIVET, blind	1	
47	90201-047A2	WASHER, plate	2	
48	90179-05523	NUT	2	
49	90149-05224	SCREW	2	
50	90202-05180	WASHER, plate	2	

E15

FIG. 39 GENERATOR

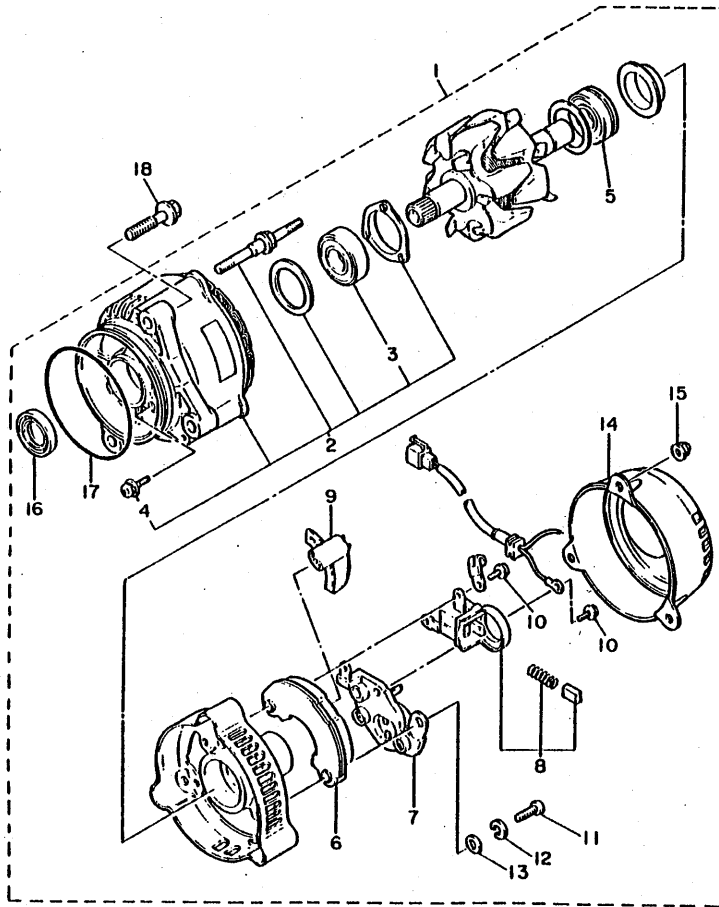

REF. NO.	PART NO.	DESCRIPTION	Q'TY	REMARKS
* 1	2GH-81600-51	A.C. GENERATOR ASSY	1	
2	2KT-81634-50	•STATOR ASSY	1	
3	36Y-81643-30	••BEARING	1	
4	2KT-81645-50	••SCREW	3	
5	36Y-81643-50	•BEARING	1	
6	36Y-81970-50	•RECTIFIER ASSY	1	
7	36Y-81910-50	•VOLTAGE REGULATOR ASSY	1	
8	2KT-81619-50	•BRUSH HOLDER ASSY	1	
9	36Y-81972-50	•COVER, rectifier	1	
10	36Y-81645-30	•SCREW	2	
11	98501-05018	•SCREW, Pan head	3	
12	92901-05100	•WASHER, sPrin8	3	
13	92901-05600	•WASHER, Plate	3	
14	2GH-81604-50	•COVER ASSY	1	
15	2KT-81675-50	•NUT	3	
16	36Y-81638-50	•OIL SEAL	1	
17	2KT-81642-50	•O-RING	1	
18	95816-08030	BOLT, flange	3	

FWD
2GH300-7390

FIG. 40 PICK UP COIL. GOVERNOR

REF. NO.	PART NO.	DESCRIPTION	Q'TY	REMARKS
* 1	2GH-81670-11	PICK-UP ASSY	1	
2	93210-19216	O-RING	1	
3	95026-06012	BOLT, flange	1	

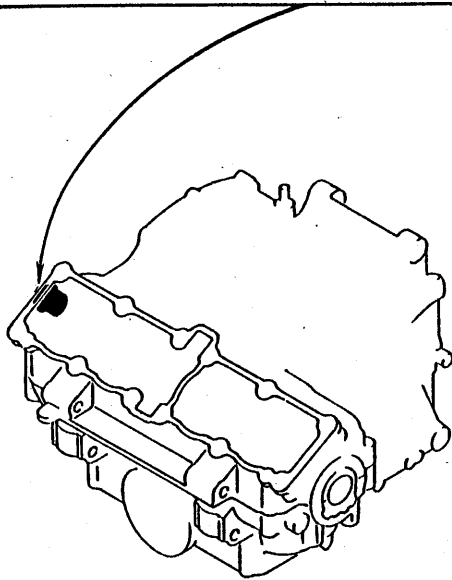
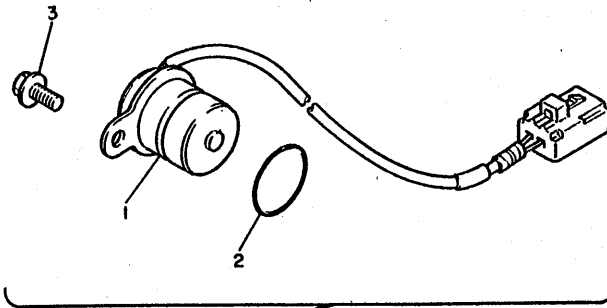

2GH300-7400

F3

FIG. 41 STARTING MOTOR

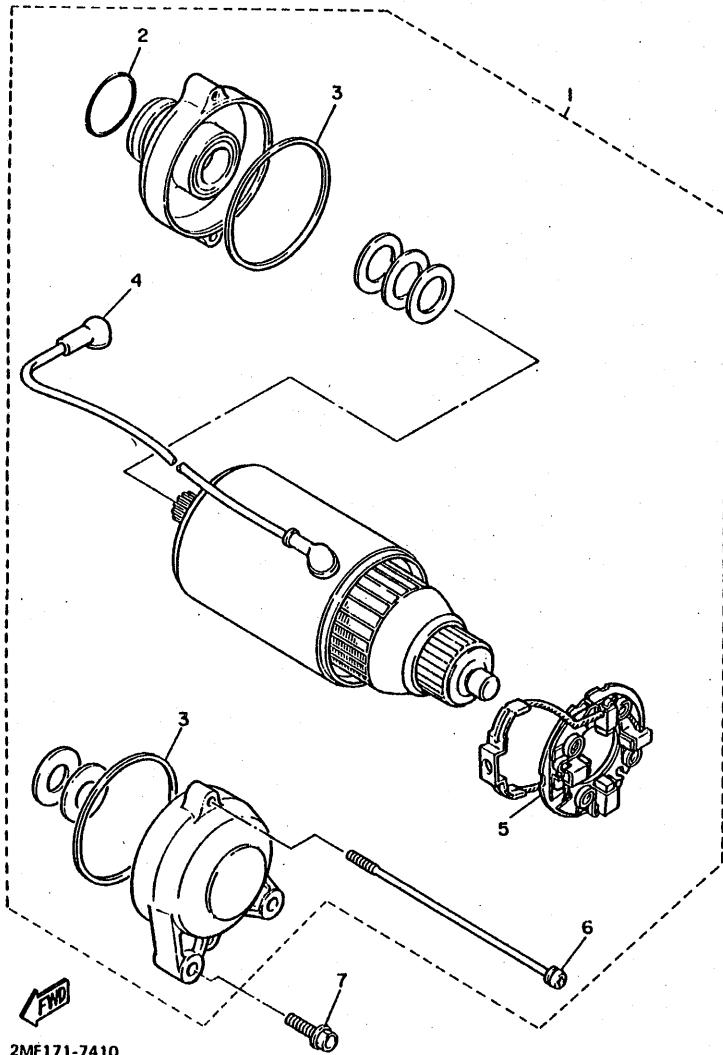

2MF171-7410

REF. NO.	PART NO.	DESCRIPTION	Q'TY	REMARKS
1	2KT-81800-60	STARTING MOTOR ASSY	1	
2	26H-81847-00	•O-RING	1	
3	4G0-81844-00	•GASKET	2	
4	1AE-81815-00	•WIRE, starter	1	
5	1AE-81840-00	•BRUSH HOLDER ASSY	1	
6	1AE-81826-00	•BOLT	2	
7	95816-06025	BOLT, flange	2	

FIG. 42. FLASHER LIGHT

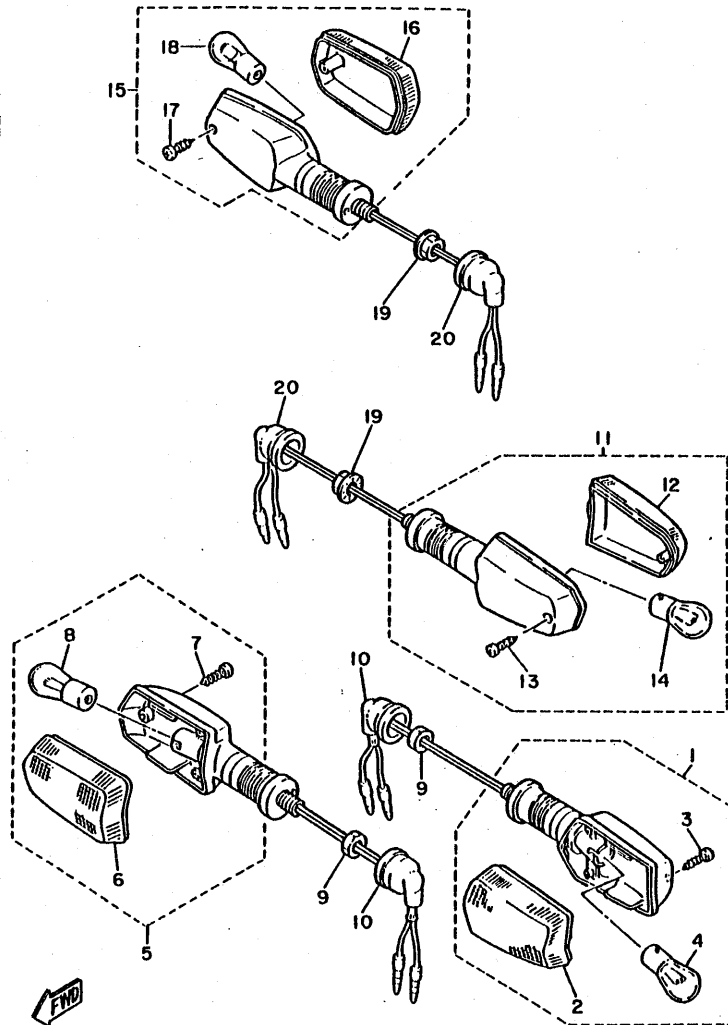

REF. NO.	PART NO.	DESCRIPTION	Q'TY	REMARKS
1	1TV-83310-00	FRONT FLASHER LIGHT ASSY 1	1	
2	51L-83332-01	•LENS, flasher	1	
3	97706-40620	•SCREW, tapping	1	
4	306-83311-40	•BULB, flasher (12V-21W)	1	
5	1TV-83320-00	FRONT FLASHER LIGHT ASSY 2	1	
6	51L-83342-01	•LENS, flasher 2	1	
7	97706-40620	•SCREW, tapping	1	
8	306-83311-40	•BULB, flasher (12V-21W)	1	
9	95306-12600	NUT	2	
10	18G-83365-00	CAP	2	
11	51J-83330-00	REAR FLASHER LIGHT ASSY 1	1	
12	1VU-83332-00	•LENS, flasher	1	
13	97706-40620	•SCREW, tapping	1	
14	306-83311-40	•BULB, flasher (12V-21W)	1	
15	51J-83340-00	REAR FLASHER LIGHT ASSY 2	1	
16	1VU-83342-00	•LENS, flasher 2	1	
17	97706-40620	•SCREW, tapping	1	
18	306-83311-40	•BULB, flasher (12V-21W)	1	
19	95706-12500	NUT, flange	2	
20	18G-83365-00	CAP	2	



2GH300-7420

F5

FIG. 43 METER

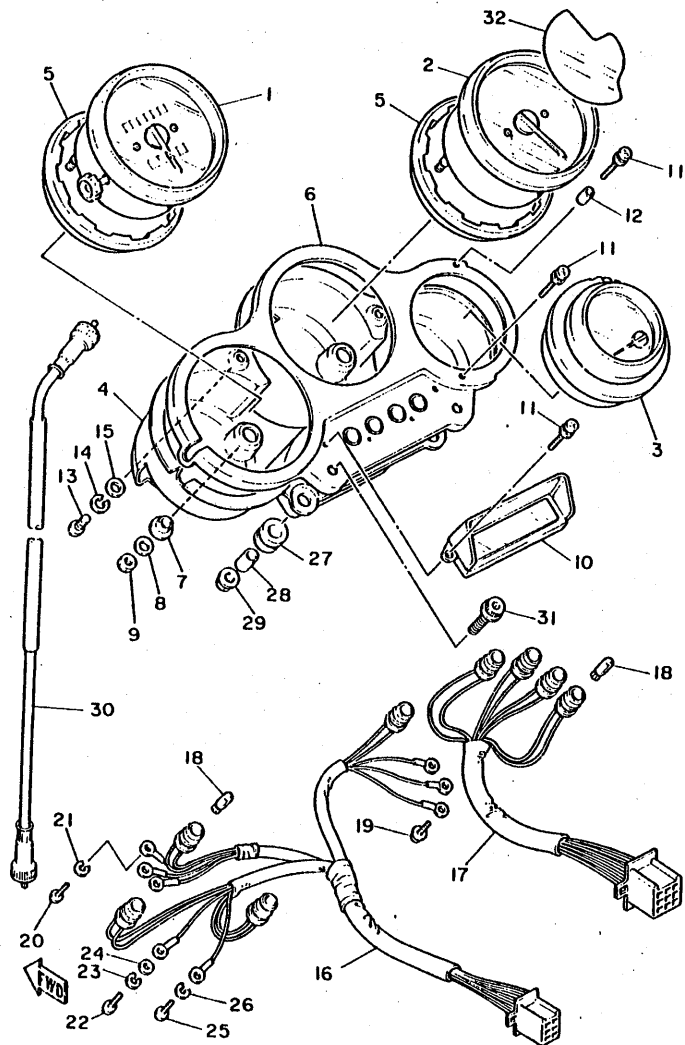

2LA332-7431

REF. NO.	PART NO.	DESCRIPTION	Q'TY	REMARKS
* 1	2GH-83570-F1	SPEEDOMETER ASSY	1	
2	2GH-83540-00	TACHOMETER ASSY	1	
3	2GH-83590-00	WATER TEMPERATURE ASSY	1	
4	2GH-83579-00	COVER, meter 2	1	
5	1AE-83513-00	DAMPER	2	
6	2GH-83611-00	PANEL, meter	1	
7	584-83523-00	DAMPER	4	
8	90201-052E2	WASHER, Plate	4	
9	95306-05600	NUT	4	
10	2GH-83612-00	COVER, meter Panel	1	
11	2GH-83546-00	BOLT	4	
12	1AR-83522-00	COLLAR	1	
13	98506-04008	SCREW, Pan head	3	
14	92906-04100	WASHER, sPrinG	3	
15	92906-04600	WASHER, Plate	3	
*16	2GH-83509-01	SOCKET CORD ASSY	1	
17	1AR-83520-00	SOCKET CORD ASSY	1	
*18	4G1-84744-00	BULB (12V 3.4W)	8	
19	90159-03102	SCREW, with washer	3	
20	98501-03010	SCREW, Pan head	3	
21	92990-03100	WASHER, sPrinG	3	
22	98580-04010	SCREW, Pan head	2	
23	92902-04100	WASHER, sPrinG	2	
24	92901-04600	WASHER, Plate	2	
25	98501-03012	SCREW, Pan head	1	
26	92990-03100	WASHER, sPrinG	1	
27	90480-14182	GRDMMET	2	
28	90387-066H4	COLLAR	2	

FIG. 43 METER

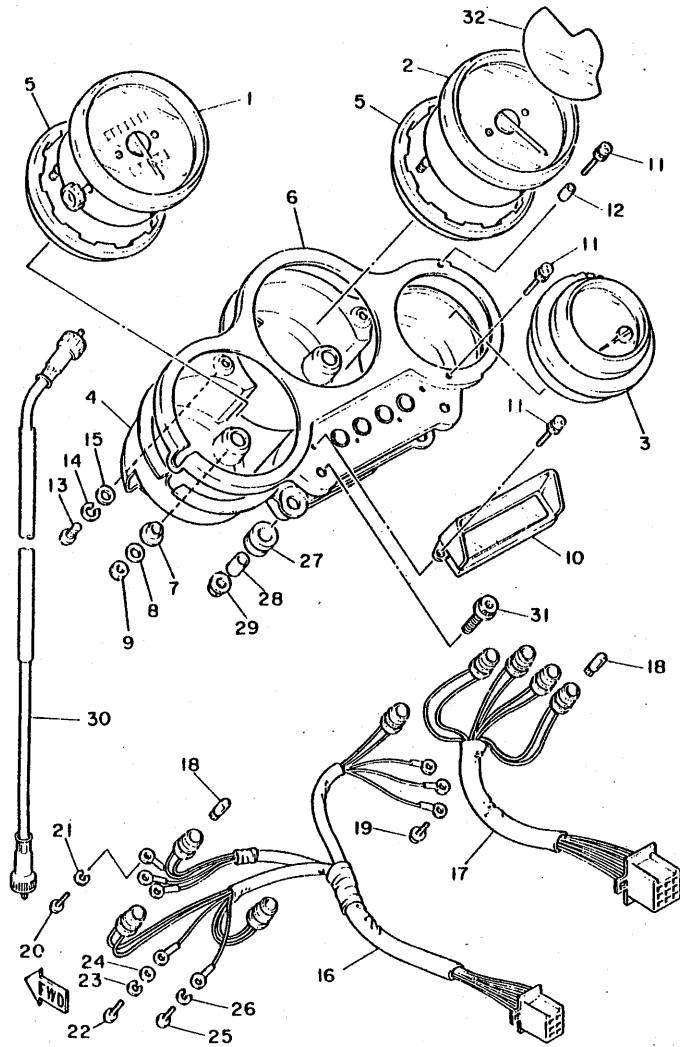

2LA332-7431

REF. NO.	PART NO.	DESCRIPTION	Q'TY	REMARKS
29	95306-06600	NUT	2	
30	2GH-83550-00	SPEEDMETER CABLE ASSY	1	
31	90109-064E7	BOLT	2	
*32	2GH-84142-00	SEAT, emblem	1	

F7

FIG. 44 HEADLIGHT

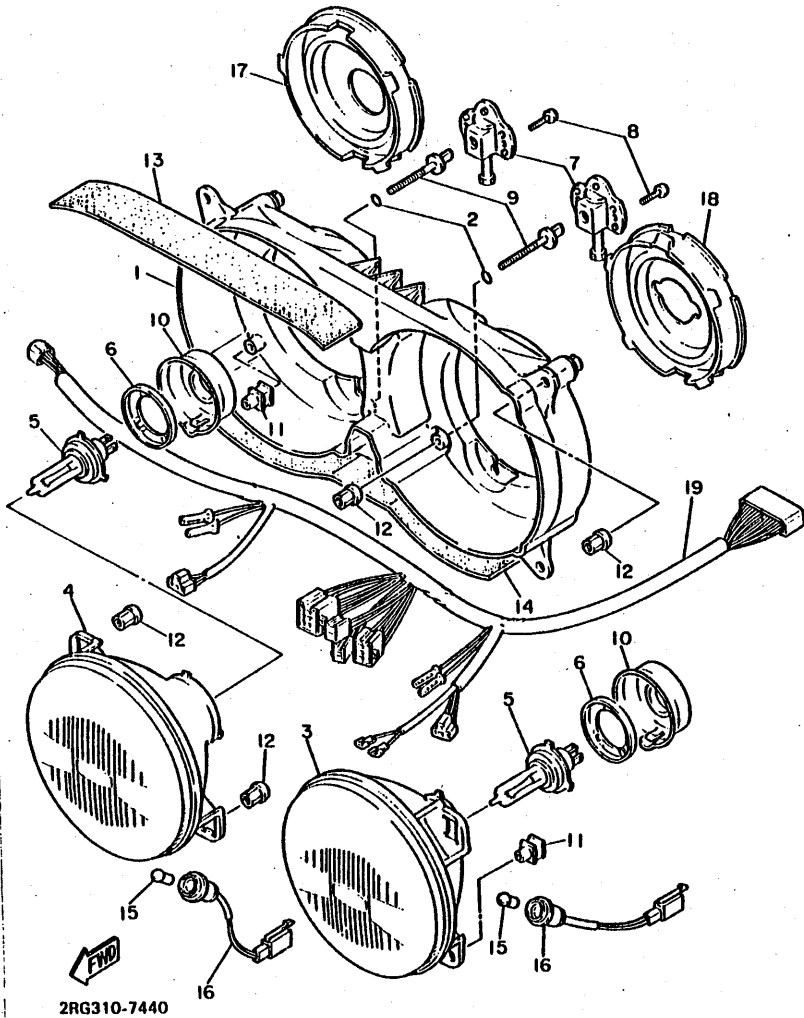

REF. NO.	PART NO.	DESCRIPTION	Q'TY	REMARKS
1	2LJ-84330-A0	BODY ASSY	1	
2	93210-06632	O-RING	2	
3	2RG-84320-E0	LENS ASSY (L)	1	
4	2RG-8432A-E0	LENS ASSY (R)	1	
5	*	BULB (12V-35/35W)	2	LM halogen
6	2F9-84375-00	FITTING PLATE, bulb	2	
7	46X-8430M-00	GEAR UNIT ASSY	2	
8	97706-40616	SCREW, tapping	4	
9	2AX-84331-00	SCREW, rim adjusting	2	
10	2F9-84397-01	COVER, socket	2	
11	51L-8431U-00	HOLDER	2	
*12	51L-84334-00	NUT, adjusting	4	
13	2GH-84396-00	COVER	1	
14	2GH-84396-10	COVER	1	
15	123-83516-21	BULB (12V-3.4W)	2	
16	2LA-84312-00	SOCKET	2	
17	2LA-84397-00	COVER, socket	1	
18	2LA-84397-10	COVER, socket	1	
19	2RG-84359-00	CORD, headlight	1	

FIG. 45 TAILLIGHT

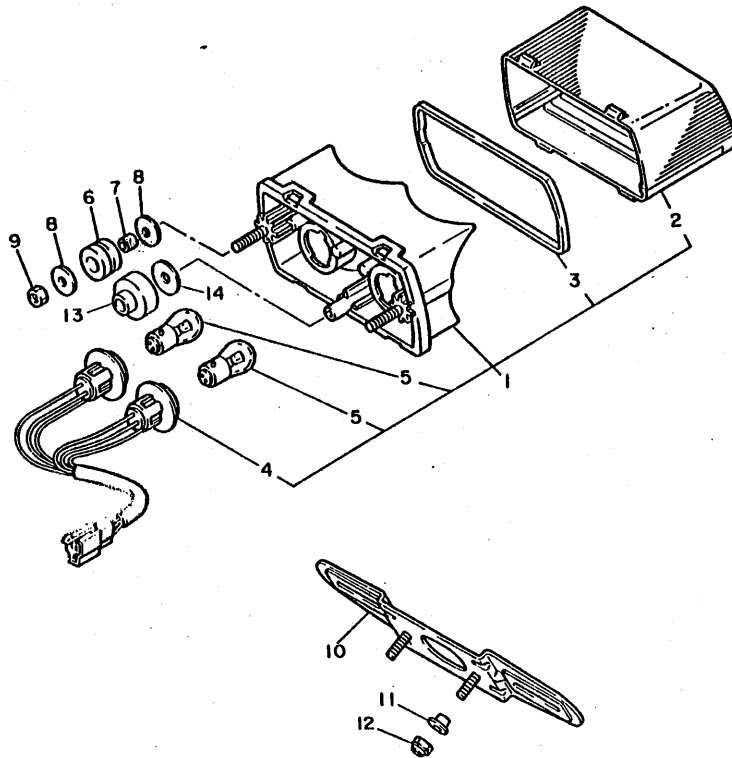

REF. NO.	PART NO.	DESCRIPTION	Q'TY	REMARKS
1	47X-84710-E0	TAILLIGHT UNIT ASSY	1	
2	47X-84721-00	•LENS, taillight	1	
3	47X-84723-00	•GASKET, tail lens	1	
4	47X-84735-00	•CORD ASSY	1	
5	31L-84714-00	•BULB, taillight (12V-21/5W)	2	
6	90480-18276	GROMMET	2	
*7	90387-060A7	COLLAR	2	
8	90201-063J2	WASHER, Plate	4	
9	95302-06600	NUT	2	
*10	1KH-84751-00-90	BRACKET, licence	1	uni chrome(black)
11	90387-061M0	COLLAR	2	
12	95606-06100	NUT, u	2	
13	90480-15259	GROMMET	1	
14	92906-10200	WASHER	1	



2GH300-7450

FIG. 46 HANDLE SWITCH, LEVER

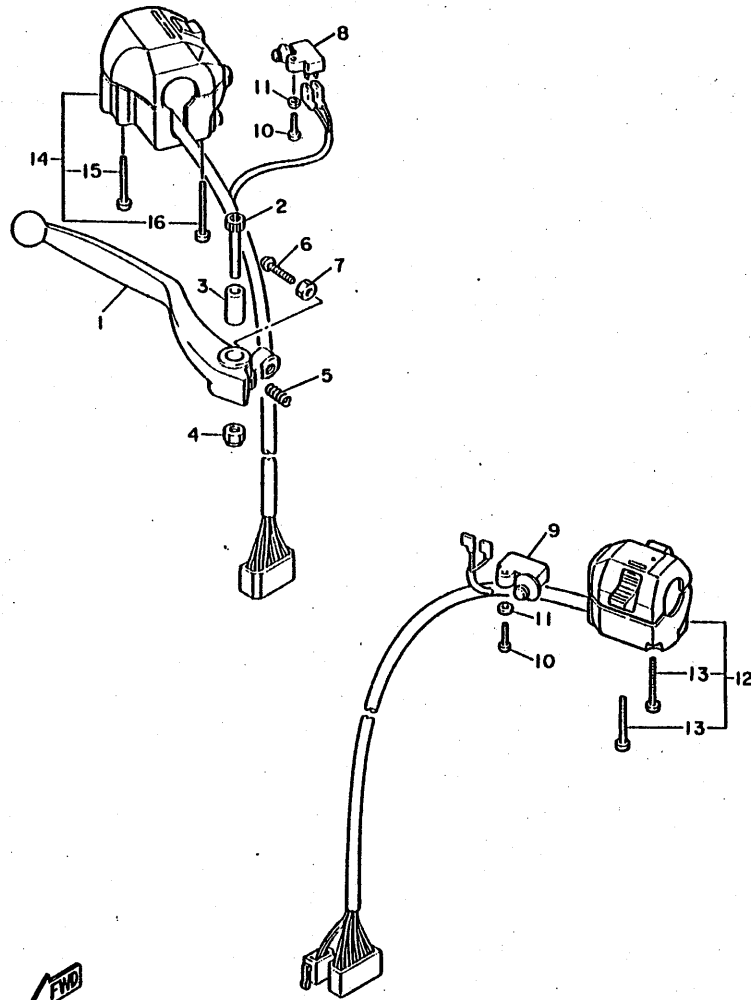

REF. NO.	PART NO.	DESCRIPTION	Q'TY	REMARKS
1	36Y-83922-00	LEVER 2	1	
2	90110-06074	BOLT, hexagon socket head	1	
3	36Y-83913-00	COLLAR, lever 1	1	
4	95606-06100	NUT, u	1	
5	90501-10312	SPRING, compression	1	
6	90149-06153	SCREW	1	
7	90170-06010	NUT	1	
*8	36Y-83980-01	FRONT STOP SWITCH ASSY	1	
9	36Y-82917-00	SWITCH	1	
10	98506-04018	SCREW, Pan head	2	
11	92906-04600	WASHER, Plate	2	
12	2EN-83972-00	SWITCH, handle 4	1	
13	98501-05035	•SCREW, Pan head	2	
14	2GH-83963-00	SWITCH, handle 3 (RIGHT)	1	
15	98506-05040	•SCREW, Pan head	1	
16	98506-05045	•SCREW, Pan head	1	



2GH300-7460

F10

FIG. 47 ELECTRICAL 1

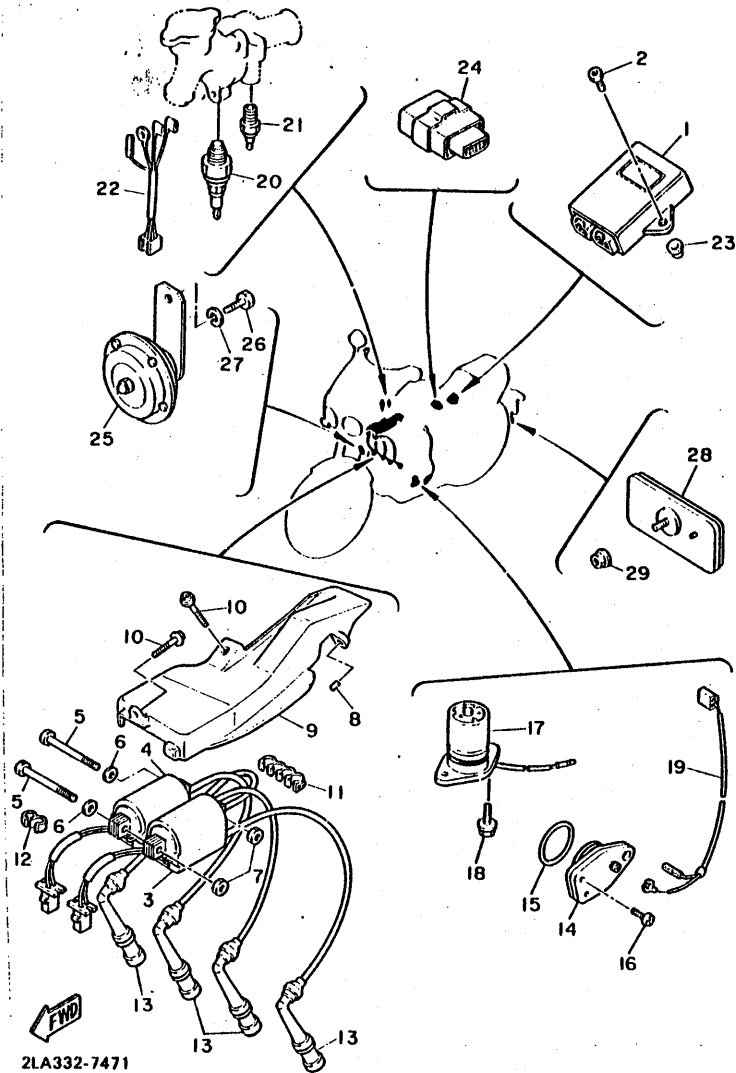

2LA332-7471

REF. NO.	PART NO.	DESCRIPTION	Q'TY	REMARKS
1	2GH-82305-10	IGNITOR UNIT ASSY	1	
2	90110-06158	BOLT, hexagon socket head	1	
3	2GH-82310-10	IGNITION COIL ASSY	1	
4	2GH-82320-10	IGNITION COIL ASSY	1	
5	97006-06065	BOLT	2	
6	92906-06600	WASHER, Plate	2	
7	95306-06600	NUT	2	
* 8	90445-106F5	HOSE	1	
9	2GH-28219-00	COVER 1	1	
10	90159-06042	SCREW, with washer	2	
11	2GH-21335-00	CLAMP, wire harness 1	1	
12	90464-10075	CLAMP	1	
13	2KT-82370-00	PLUG CAP ASSY	4	
14	1AE-82540-00	NEUTRAL SWITCH ASSY	1	
15	93210-29196	O-RING	1	
16	92502-06016	SCREW, Pan head	2	
17	4H7-85720-01	OIL LEVEL GAUGE ASSY	1	
18	95026-06016	BOLT, flange	2	
19	1AE-82509-00	WIRE, sub lead	1	
* 20	2EL-82560-00	THERMO SWITCH ASSY	1	
21	11H-83591-00	THERMO UNIT	1	
22	2GH-82509-00	WIRE, sub lead	1	
23	31A-14477-00	PLATE	1	
24	41R-83350-71	FLASHER RELAY ASSY	1	
25	4V8-83371-20	HORN	1	
26	97326-08012	BOLT	1	
27	92906-08100	WASHER, sPring	1	
28	3G1-85130-01	REAR REFLECTOR ASSY	1	

FIG. 47 ELECTRICAL 1

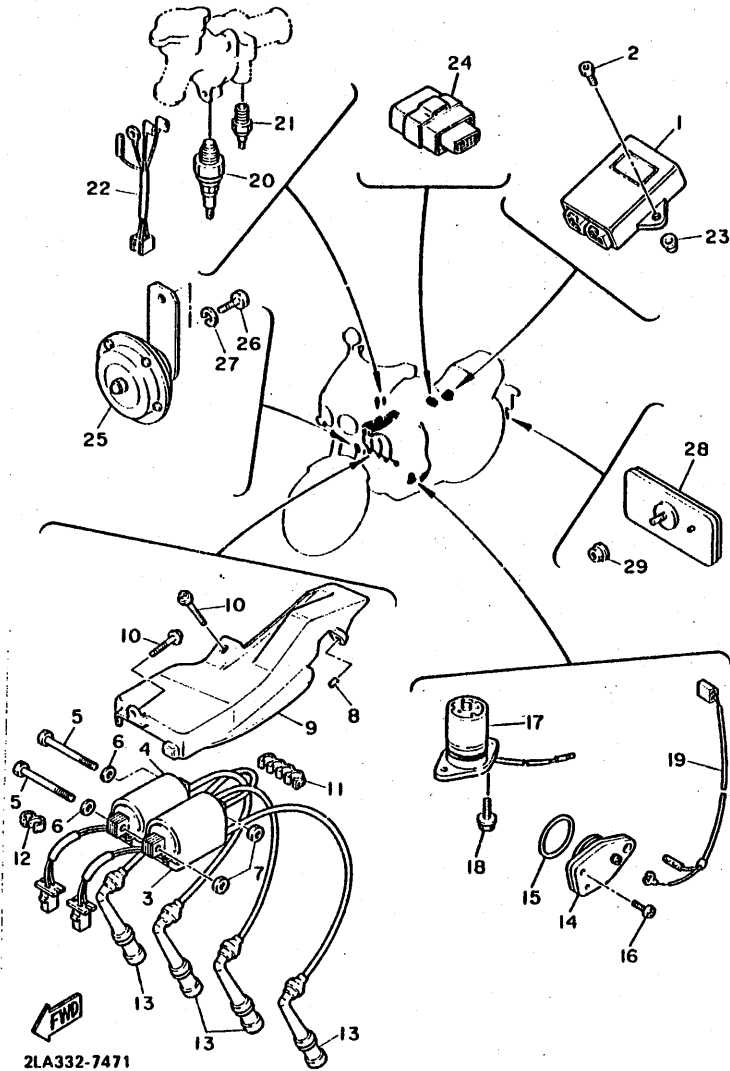

REF. NO.	PART NO.	DESCRIPTION	Q'TY	REMARKS
29	95701-05500	NUT, flange	1	

F12

FIG. 48 ELECTRICAL 2

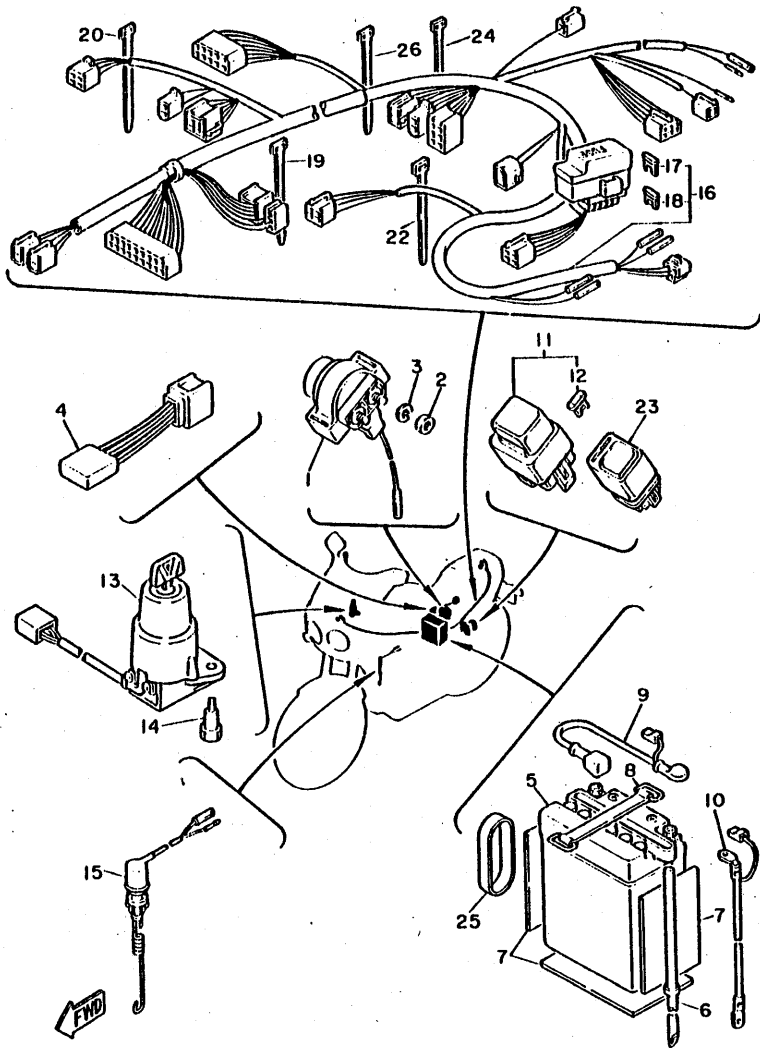

REF. NO.	PART NO.	DESCRIPTION	Q'TY	REMARKS
1	42X-81940-00	STARTER SWITCH ASSY	1	
2	95302-06700	NUT	2	
3	92990-06100	WASHER, sPrinE	2	
4	4H7-81960-M0	DIODE	1	
5	447-82110-78	BATTERY ASSY (FB14L-A2)	1	yamaha
6	90445-083A4	HOSE	1	
7	5G3-82121-00	PAD, battery	3	
8	2T4-82131-00	BAND, battery	1	
9	2GH-82115-00	WIRE, Plus lead	1	
10	2GH-82116-00	WIRE, minus lead	1	
11	1AE-82150-00	FUSE HOLDER ASSY	1	
12	1AE-82151-00	.FUSE (12V 30A)	2	
13	49F-82501-80	MAIN SWITCH STEERING LOCK	1	
*14	90149-06228	SCREW	2	
15	2GH-82530-00	STOP SWITCH ASSY	1	
16	2LL-82590-00	WIRE HARNESS ASSY	1	
17	2GH-82151-00	.FUSE (20A)	2	
18	42X-82151-00	.FUSE (10A)	4	
*19	437-83936-00	BAND, switch cord	2	
20	437-83936-10	BAND, switch cord	1	
22	25G-83936-00	BAND, switch cord	1	
23	25G-81950-00	RELAY ASSY	1	
*24	90464-13073	CLAMP	2	
*25	165-82124-00	BAND, battery	1	
*26	5Y9-12491-00	CLAMP 1	2	

MODIFICATION PARTS LIST

* : Interchangeable
 : Interchangeable with a set

Mark	Fig./ Ref. No.	Grid No.	Part No. for OLD	NEW	OLD	Part No. for NEW	Description	Q'ty	Modification	Remarks
				↑	→					
*	3-5	B4	2GH-11633-00	*		2GH-11633-02	PIN, piston	4	○	
*	3-7	B4	2GH-11650-00	*		2GH-11650-01	CONNECTING ROD ASSY	4	○	
*	7-3	B9	1AE-12417-01	○	*	1AE-12417-02	HOUSING, thermostat	1	○	
*	47-20	F11	47X-82560-00	○	*	2EL-82560-00	THERMO SWITCH ASSY	1	○	
*	7-10	B9	95026-06030	*		95826-06030	BOLT, flange	1	○	
*	7-30	B10	2GH-12483-00	*		2GH-12483-01	PIPE 3	1	○	
*	10-30	B15	90445-11153	*	*	90445-113F8	HOSE	1	○	
*	13-34	C6	90465-08280				CLAMP	-	-	
*	13-37	C6	2GH-15105-00	*		2GH-15105-01	NOZZLE ASSY	2	○	
*	15-10	C8	1AE-15522-00	*		1AE-15522-01	SHAFT 2	1	○	
*	20-1	C14	2GH-21110-00	*		2GH-21110-01	FRAME COMP.	1	○	
*	20-1-1	C14				2GH-2833J-00	● BRACKET 12	1	+	
*	20-1-2	C14				2GH-2833K-00	● BRACKET 13	1	+	
*	20-1-3	C14				90267-40087	● RIVET, blind	6	+	
*	20-1	C14	2GH-21110-01	○		2GH-21110-02	FRAME COMP.	1	○	
*	20-3	C14	90105-10459	○			BOLT, washer based	4→2	Δ	
*	20-34	C15		○		90105-10499	BOLT, washer based	2	+	
*	20-1	C14	2GH-21110-02	○		2GH-21110-03	FRAME CAMP.	1	○	
*	20-33	C15	90119-06061	○			BOLT, with washer	4→2	Δ	
*	20-35	C15		○		95702-06600	NUT	2	+	
*	21-1	D2				2GH-21511-00-JW	FENDER, front	1	+	urushi black
*	21-2	D2				2GH-21556-00-JW	FENDER, front 2	1	+	urushi black
*	21-24	D2				2GH-21651-00-JW	COVER, rear fender	1	+	urushi black
*	21-35	D3	2GH-28338-00	*	*	99234-00020	EMBLEM, yamaha	1	+	UR for sw/abl
			29L-28338-20	*	*	99231-00020	EMBLEM, yamaha	1	○	UR for dyb
						99236-00020	EMBLEM, yamaha	1	○	UR for urb
*	22-1	D4				2GH-W2175-20-JW	SIDE COVER 1	1	+	urushi black

..... First modification (1st edition → 1st revised edition)
 *..... Second modification (1st revised → 2nd revised edition)
 *..... Third modification (2nd revised → 3rd revised edition)

Modification Mark:

○..... Parts modified +..... Part added
 -..... Part deleted
 Δ..... Change of parts quantity

MODIFICATION PARTS LIST

* : Interchangeable
 : Interchangeable with a set

Mark	Fig./ Ref. No.	Grid No.	Part No. for OLD	NEW → OLD		Part No. for NEW	Description	Q'ty	Modification	Remarks
				NEW	OLD					
*	22-2	D4	_____			2GH-2173L-20	● GRAPHIC SET 1	1	+	for urb
*	22-3	D4	_____			2GH-21784-00	● EMBLEM 4	1	+	for urb
*	22-10	D4	_____			2GH-W2173-20-JW	SIDE COVER COMP 2	1	+	urushi black
*	22-11	D4	_____			2GH-2174L-20	● GRAPHIC SET 2	1	+	for urb
*	22-12	D4	_____			2GH-21784-00	● EMBLEM 4	1	+	for urb
*	23-29	D7	90159-06110	*		90159-06108	SCREW, with washer	2	○	
*	27-1	D12	2GH-24110-00-01	*	*	2GH-24110-00-04	FUEL TANK COMP.	1	○	UR atlantic blue/silky white
			2GH-24110-00-02	*	*	2GH-24110-00-05	FUEL TANK COMP.	1	○	UR silky white/dynasty blue
			_____			2GH-24110-00-06	FUEL TANK COMP.	1	+	UR urushi black
*	27-2	D12	2GH-24161-00	*	*	99224-00035	● EMBLEM, yamaha	2	○	UR for abl/sw, sw/dyb
			_____			99226-00030	● EMBLEM, yamaha	2	+	UR for urb
*	27-3	D12	_____			2GH-24240-20	● GRAPHIC SET	1	+	for urb
*	27-3-1	D12	_____			2GH-24162-00	● EMBLEM 2	1	+	for urb
*	27-52	D13	2LJ-14425-00	*		2GH-24185-00	DAMPER	2	○	
*	29-1	D15	_____			2GH-25168-00-WG	CAST WHEEL, front	1	+	hi tech silver
*	31-1	E3	_____			2GH-25338-00-WG	CAST WHEEL, rear	1	+	hi tech silver
*	31-29	E4	90201-177K7		○	_____	WASHER, plate	2→1	△	
*	31-36	E4	_____		○	90201-165L8	WASHER, plate	1	+	
*	34-1	E7	36Y-25850-00	*		36Y-25850-01	WASTER CYLINDER ASSY	1	○	
*	34-2	E7	36Y-25852-00	*		36Y-25852-01	● CAP, reservoir	1	○	
*	35-1	E8	1ML-26450-01	*		3BV-26450-00	MASTER CYLINDER ASSY (CLUTCH)	1	○	
*	35-6	E8	1FK-26452-00	*		1FK-26452-01	● CAP, reservoir	1	○	
*	37-20	E11	360-25855-01	*		2GU-25855-00	BUSH, diaphragm	1	○	
*	37-21	E11	1A1-25852-00	*		2GU-25852-50	CAP, reservoir	1	○	
*	38-5	E12	_____			2GH-2835G-00-JW	BODY, front upper 1	1	+	urushi black
*	38-21	E12	_____			2LL-26280-10	BACK MIRROR ASSY (LEFT)	1	+	UR for oceania (for urb)
			_____			2GH-26280-10	BACK MIRROR ASSY (LEFT)	1	+	UR for s-africa (for urb)

*..... First modification (1st edition → 1st revised edition)
 **..... Second modification (1st revised → 2nd revised edition)
 ***..... Third modification (2nd revised → 3rd revised edition)

Modification Mark:

○..... Parts modified +..... Part added
 -..... Part deleted
 △..... Change of parts quantity

F15

MODIFICATION PARTS LIST

* : Interchangeable
 ○ : Interchangeable with a set

Mark	Fig./ Ref. No.	Grid No.	Part No. for OLD			Part No. for NEW	Description	Q'ty	Modification	Remarks
				NEW → OLD	OLD → NEW					
*	38-22	E13	_____			2LL-26290-10	BACK MIRROR ASSY (RIGHT)	1	+	UR for oceania (for urb)
*	38-31	E13	90387-064M9	*	*	2GH-26290-10	BACK MIRROR ASSY (RIGHT)	1	+	UR for s-africa (for urb)
*	38-33	E13	2GH-2833J-00			90387-060A7	COLLAR	2	○	
*	38-34	E13	2GH-2833K-00			_____	BRACKET 12	-	-	
*	38-35	E13	90267-40087			_____	BRACKET 13	-	-	
*	38-36	E13	2GH-28338-00	*	*	99234-00020	RIVET, blind	-	-	
			_____			99236-00020	EMBLEM, yamaha	1	○	UR for sw/trd, sw/dyb
*	38-38	E13	_____			2GH-28315-00	EMBLEM, yamaha	1	+	UR for urb
*	38-43	E13	_____			2GH-2839H-10	EMBLEM	2	+	for urb
*	38-1-1	E14	_____			2GH-W283E-20-JW	EMBLEM 1	2	+	for urb
*	38-1-2	E14	_____			2GH-2836V-20	BODY, front lower 1	1	+	urushi black
*	38-1-9	E14	_____			2GH-W283F-20-JW	• GRAPHIC SET 3, cowling	1	+	for urb
*	38-1-10	E14	_____			2GH-W2836W-20	BODY, front lower 2	1	+	urushi black
*	38-1-17	E14	_____			2GH-2836K-00-JW	• GRAPHIC SET 4, cowling	1	+	for urb
*	38-1-31	E15	2GH-28315-10	*	*	99234-00070	PANEL, inner 1	1	+	urushi black
			_____			99232-00070	EMBLEM, yamaha	2	○	UR for sw/trd, sw/dyb
*	38-1-43	E15	90267-40029			_____	EMBLEM, yamaha	2	+	UR for urb
*	38-1-44	E15	90201-047A2			_____	RIVET, blind	2→1	Δ	
*	39-1	F2	2GH-81600-50	*		2GH-81600-51	WASHER, plate	4→2	Δ	
*	40-1	F3	2GH-81670-10	*		2GH-81670-11	A.C.GENERATOR ASSY	1	○	
*	43-32	F7	_____			2GH-84142-00	PICK-UP ASSY	1	○	
*	44-12	F8	51L-84332-00	*		51L-84334-00	SEAT, emblem	1	+	
*	45-7	F9	90387-064M9	*	*	90387-060A7	NUT, adjusting	4	○	
*	45-10	F9	1KH-84751-00-98	*	*	1KH-84751-00-90	COLLAR	2	○	
*	46-8	F10	36Y-83980-00	*		36Y-83980-01	BRACKET, licence	1	○	uni chrome (black)
*	48-14	F13	90109-06614	*		90149-06228	FRONT STOP SWITCH ASSY	1	○	
			_____			_____	SCREW	2	○	

*..... First modification (1st edition → 1st revised edition)
 **..... Second modification (1st revised → 2nd revised edition)
 ***..... Third modification (2nd revised → 3rd revised edition)

Modification Mark:
 ○..... Parts modified +..... Part added
 -..... Part deleted
 Δ..... Change of parts quantity

NUMERICAL INDEX

NUMERICAL INDEX

PART NO.	GRID NO.	PART NO.	GRID NO.	PART NO.	GRID NO.	PART NO.	GRID NO.	PART NO.	GRID NO.	PART NO.	GRID NO.
2GH-21190-00-35	C-14	2GH-22210-00	D- 8	2GH-24181-00	D-12	2GH-25810-00	E- 2	1AE-26299-00	E-13	2GH-28338-00	D- 3
2GH-21238-00	E-12	2GH-22311-00	D- 6	2GH-24182-00	D-12	2GH-25810-10	E- 2	2GH-26311-01	E- 6		E-14
2GH-21245-00	D- 4	2GH-23102-00	D-10	2GH-24183-00	D-12	2KT-25810-50	E- 5	2GH-26312-01	E- 6	29L-28338-20	D- 3
2GH-21308-00	D- 3	2GH-23103-00	D-10	3V6-24183-00	D-12	1AE-25819-50	E- 5	2GH-26331-00	E- 6	2GH-2834G-00	D-12
2GH-21335-00	F-11	2GH-23110-00	D-10	2GH-24184-00	D-12	1FK-25827-00	E- 5	5H0-26393-00	E- 6	2GH-2834H-00	D-12
2GH-2136A-00	C-14		D-11	2GH-24186-00	D-12	1FK-25828-00	E- 5	341-26397-01	F-13	2GH-2834V-00	E-12
2GH-2136E-00	C-14	2GH-23111-00	D-10	2GH-24187-00	D-12	2GH-25830-00	E- 2	1ML-26450-01	E- 8	2GH-28345-00	E-13
2GH-2136Z-00	E-15		D-11	2GH-24191-00	D-12	2KT-25831-00	E- 5	1FK-26452-00	E- 8	2GH-28346-00	E-14
1UF-2139U-00	C-14	4H7-23119-00	D-10	2GH-24240-00	D-12	1KT-25836-00	E- 2	1AE-26454-00	E- 8	2GH-28347-00	E-13
1UF-2139X-00	C-14	36Y-23125-10	D-10	2GH-24240-10	D-12	51J-25836-00	E- 5	26H-26455-00	E- 8	36Y-28348-00	E-12
1WG-21459-00	C-14	2GH-23126-00-38	D-10	2GH-24312-00	D-13	341-25846-00	D-15	26H-26464-00	E- 8	2GH-2835G-00-GE	E-12
4X7-2149Y-00	B-14	1AE-23128-00	D-11	2GH-24313-00	D-13	2GH-25850-50	E-11	1AE-26467-00	E- 8	2GH-28356-00	E-12
2GH-21511-00-GE	D- 2	1UJ-23128-00	D-11	2GH-24366-00	D-13	36Y-25850-00	E- 7	2GH-26470-00	E- 8	2GH-2836F-00	E- 1
1A8-21518-00	D- 2	122-23129-00	D-10	2GH-24398-00	D-13	1A1-25852-00	E-11	2GH-27211-00	E-11	2GH-2836K-00-GE	E- 1
2GH-21556-00-GE	D- 2	47X-2313A-00	D- 2	2GH-24500-00	D-12	36Y-25852-00	E- 7	31A-27222-00	E-11	2GH-2836V-00	E-12
2H7-21628-00	E-14	2GH-23136-00-38	D-10	2GH-24510-00	D-12	36Y-25854-00	E- 7	2GH-27311-00	E- 9	2GH-2836V-10	E-12
2GH-21629-00	D- 2	2GH-23141-00	D-10	2HG-24512-00	D-12	360-25854-00	E-11	2KT-27315-00	E- 9	2GH-2836W-00	E-13
4G0-21639-00	D- 3		D-11	1JK-24534-00	D-12	360-25855-01	E-11	1TX-27351-00	E- 9	2GH-2836W-10	E-13
2KT-21649-00	D- 2	36Y-23144-00	D-10	3H3-24534-00	D-13	4L0-25862-00	E- 7	2GH-2741L-00	E- 9	2GH-28368-00	E-14
2GH-21651-00-VA	D- 2	36Y-23145-00	D-10	1FK-24560-00	D-13		E- 8	2GH-27410-00	E- 9	2GH-28368-10	E-14
1JK-21652-00	E-12	36Y-23146-10	D-10	1JK-24602-11	D-13		E- 7	2GH-27413-00	E- 9	2KR-28368-00	E-14
2GH-21660-00	D- 2		D-11	51X-24705-00	D-14	36Y-25867-00	E- 7		E-10	51L-28371-00	D-12
1KH-21717-00	D- 4	36Y-23147-00	D-10	1KT-24718-00	D-14	2GH-25872-00	E- 7		E-10	2GH-28378-00	E-14
2GH-2173L-00	D- 4		D-11	1KT-24728-00	D-14	2GH-25872-50	E-11	2H7-27414-00	E-10	2GH-2838N-00	E-14
2GH-21732-00	D- 3	2GH-23149-00	D-10	2GH-24730-00	D-14	2GH-25873-00	E- 7	2GH-2742L-00	E- 9	2GH-2838R-00	E-14
	D- 5		D-11	2GH-24731-00	D-14	2GH-25875-00	D- 2	2GH-27420-00	E- 9	2GH-2838T-00	E-12
	D-13	26H-23156-00	D-10	2GH-24741-00	D-14	2GH-25875-50	D- 7	2GH-27431-00	E- 9	2GH-2838U-00	E-13
2GH-21735-00	D- 3	36Y-23157-00	D-10	2GH-24776-00	D-14	2GH-25876-00	E- 4	1HX-27437-00	E- 9	2LJ-28381-00	E-12
2GH-2174L-00	D- 4		D-11	1JK-2478F-00	D-14	11U-25885-00	E- 7		E-10	2GH-28390-00	E-14
		4V4-23158-L0	D-10	47X-24796-00	D-14	31A-25894-01	E-11	2GH-27441-00	E-10	2GH-28390-10	E-14
	D- 2		D-11	341-25149-00	D-15	2GH-25895-00	E-11	2GH-27442-00	E- 9	2GH-28396-00	E-12
29N-21747-00	D- 2	2GH-23170-00	D-10	2GH-25168-00-UA	D-15	2GH-25919-00	E- 2	2GH-27443-00	E- 9	2GH-28397-00	E-13
5G3-21747-00	D- 4		D-11	47X-25181-00	D-15	29L-25919-00	E- 5	1KT-27813-00	E-11	2GH-81600-50	F- 2
2GH-21781-00	D- 4	36Y-23171-00	D-10	2GH-25190-00	D-15	1KT-25924-00	E- 2	2GH-28100-10	D- 3	2GH-81604-50	F- 2
2GH-21783-00	D- 4		D-11	2GH-25338-00-UA	E- 3	26H-25924-00	E- 5		E- 5	2KT-81619-50	F- 2
2GH-21788-00	D- 4	2GH-23173-00	D-10	2GH-25364-00	E- 3	1KT-25925-00	E- 2	4K5-2814E-10	D- 3	2KT-81634-50	F- 2
2GH-21789-00	D- 4		D-11	36Y-25366-01	E- 3	26H-25925-00	E- 5	4K5-28186-00	D- 3	36Y-81638-50	F- 2
1KF-21816-00	D- 5	4V4-23181-L0	D-10	1WG-25371-00	E- 3	2GH-2612E-00	E- 7	2GH-28219-00	F-11	2KT-81642-50	F- 2
2GH-21871-00	D- 5		D-11	2GH-25381-00	E- 4	2GH-26121-00	E- 6	2GH-2831W-00	E-15	36Y-81643-30	F- 2
1AA-21874-00	D- 5	2GH-23340-00	D-11	2GH-25388-00	E- 3	2GH-26122-00	E- 6	2GH-28315-10	E-14	36Y-81643-50	F- 2
4L0-21875-00	D- 5	2GH-23415-00	D- 9	2GH-25389-00	E- 3	2GH-2622F-00	E- 6	2GH-2832U-00	E- 6	2KT-81645-50	F- 1
2GH-22110-00	D- 6	26H-23418-01	D- 9	29L-25398-00	D-15	47X-26240-00	E- 6	2GH-28321-01	E-14	36Y-81645-30	F- 1
36Y-22127-00	D- 6	2GH-23435-00	D- 9		E- 3	47X-26241-00	E- 6	2GH-28322-00	E-14	2GH-81670-10	F- 3
2GH-22128-00	D- 6	10L-23469-00	E- 6	29L-25398-10	D-15	2GH-26246-10	E- 6	2GH-28328-00	E-14	2KT-81675-50	F- 2
2GH-22141-00	D- 6	2GH-24110-00-01	D-12	29L-25398-20	D-15	2GH-26280-00	E-13	2GH-28328-10	E-14	2KT-81800-60	F- 4
2GH-22151-20	D- 6	2GH-24110-00-02	D-12		E- 3	2LL-26280-00	E-13	2GH-2833F-00	E-15	1AE-81815-00	F- 4
2GH-22152-20	D- 7	2GH-24136-00	D-13	2GH-25446-20-33	E- 3	2GH-26290-00	E-13	2GH-2833G-00	E-15	1AE-81826-00	F- 4
2KT-2217A-00	D- 6	2GH-24161-00	D-12		E- 3	2LL-26290-00	E-13	2GH-2833J-00	E-14	1AE-81840-00	F- 4
1WG-2217M-00	D- 6				E- 3	1AE-26298-00	E-13	2GH-2833K-00	E-14	4G0-81844-00	F- 4
36Y-22184-00	D- 6										

NUMERICAL INDEX

PART NO.	GRID NO.	PART NO.	GRID NO.	PART NO.	GRID NO.
26H-81847-00	F- 4	26H-83540-00	F- 6	90105-06478	D- 2
36Y-81910-50	F- 2	26H-83546-00	F- 6	90105-07342	B- 7
42X-81940-00	F-13	26H-83550-00	F- 7	90105-08321	E- 3
25G-81950-00	F-13	26H-83570-F1	F- 6	90105-08475	C-14
36Y-81970-50	F- 2	26H-83579-00	F- 6	90105-09373	C- 5
36Y-81972-50	F- 2	26H-83590-00	F- 6	90105-10308	E- 2
4H7-81980-M0	F-13	11H-83591-00	F-11		E- 5
447-82110-78	F-13	26H-83611-00	F- 6	90105-10316	E-10
26H-82115-00	F-13	26H-83612-00	F- 6	90105-10454	D- 6
26H-82116-00	F-13	1AE-83912-00	E- 8	90105-10459	C-14
5G3-82121-00	F-13	36Y-83913-00	F-10	90105-10476	E-14
122-82131-00	D- 3	36Y-83922-00	F-10	90105-10496	E-14
2T4-82131-00	F-13	25G-83936-00	F-13	90109-064E7	E- 9
1AE-82150-00	F-13	437-83936-00	F-13	90109-065A8	F- 6
1AE-82151-00	F-13	437-83936-10	F-13	90109-065A9	D- 4
26H-82151-00	F-13	26H-83940-00	E- 6	90109-06614	D- 2
42X-82151-00	F-13	26H-83963-00	F-10	90109-067A0	F-11
26H-82305-10	F-11	2EN-83972-00	F-10	90109-06746	D- 2
26H-82310-10	F-11	36Y-83980-00	F-10	90109-083A8	C- 4
26H-82320-10	F-11	46X-8430M-00	F- 8	90109-083E2	E- 9
2KT-82370-00	F-11	51L-8431U-00	F- 8	90109-08718	E- 2
49F-82501-80	F-13	2LA-84312-00	F- 8		E- 5
1AE-82509-00	F-11	2RG-8432A-E0	F- 8	90109-103A9	E-10
26H-82509-00	F-11	2RG-84320-E0	F- 8	90109-103E4	C-14
26H-82530-00	F-13	2LJ-84330-A0	F- 8	90109-103E7	D- 8
1AE-82540-00	F-11	2AX-84331-00	F- 8	90109-104E6	E- 9
47X-82560-00	F-11	51L-84332-00	F- 8	90110-05079	E-13
2LL-82590-00	F-13	2RG-84359-00	F- 8	90110-05112	D-13
36Y-82917-00	F-10	2F9-84375-00	F- 8	90110-06074	F-10
1TV-83310-00	F- 5	2GH-84396-00	F- 8	90110-06083	E-13
306-83311-40	F- 5	2GH-84396-10	F- 8	90110-06142	B-10
		2F9-84397-01	F- 8	90110-06157	E- 6
1TV-83320-00	F- 5	2LA-84397-00	F- 8	90110-06158	F-11
51J-83330-00	F- 5	2LA-84397-10	F- 8	90110-08066	E-10
1VU-83332-00	F- 5	47X-84710-E0	F- 9	90110-08096	C- 4
51L-83332-01	F- 5	31L-84714-00	F- 9	90110-08150	C-14
51J-83340-00	F- 5	47X-84721-00	F- 9	90110-10154	C-14
1VU-83342-00	F- 5	47X-84723-00	F- 9	90116-08504	B- 2
51L-83342-01	F- 5	47X-84735-00	F- 9	90116-09458	C- 5
41R-83350-71	F-11	4G1-84744-00	F- 6	90116-09500	C- 5
18G-83365-00	F- 5	1KH-84751-00-98	F- 9	90116-09501	C- 5
4V8-83371-20	F-11	3G1-85130-01	F-11	90116-10485	E- 3
26H-83509-01	F- 6	4H7-85720-01	F-11	90119-06052	D- 2
1AE-83513-00	F- 6	90101-06576	C- 4	90119-06056	B-13
123-83516-21	F- 8	90101-08647	E- 3	90119-06061	C-15
1AR-83520-00	F- 6	90101-10659	D- 6	90119-06097	D- 4
1AR-83522-00	F- 6	90101-12673	D- 6	90149-05224	E-15
584-83523-00	F- 6	90105-06153	B- 2	90149-05244	E-13
		90105-06362	B- 2		
		90105-06477	D- 2		

NUMERICAL INDEX

PART NO.	GRID NO.	PART NO.	GRID NO.	PART NO.	GRID NO.
90149-06011	D-13	90201-062K2	B- 9	90387-060A7	D- 4
90149-06150	D- 3	90201-063J2	F- 9	90387-06033	B- 9
90149-06153	F-10	90201-06643	C-12	90387-061G0	E- 9
90149-06184	E-14	90201-08083	E-11		E-10
90149-06243	E-14	90201-08087	C- 5	90387-061M0	D- 2
90150-05020	E-12	90201-081H4	C- 4		F- 9
90151-06014	C- 6	90201-08544	D-11	90387-064J1	D- 2
90151-08022	C- 8	90201-086J0	C-14	90387-064L2	D- 2
90152-06014	C- 7	90201-096J9	B- 2	90387-064M9	E-14
90154-06043	E-14		C- 5		F- 9
90154-06046	E-14	90201-10118	E- 7	90387-065T2	D- 2
90157-05079	E- 9		E- 8	90387-06553	D-12
	E-10		E-11	90387-066H4	F- 6
90159-03102	F- 6	90201-10437	D- 6	90387-067K8	B-12
90159-06033	D- 4	90201-10669	E-10	90387-067N5	E-13
90159-06042	D- 2	90201-12575	C-13	90387-06704	D- 7
	F-11	90201-126A7	D- 6	90387-07037	B- 9
90159-06056	D- 2	90201-14222	D- 6	90387-071E0	E-15
	D- 5	90201-150H2	C- 9	90387-100T8	D- 6
	D- 6	90201-15238	D-15	90387-102T0	D- 8
90159-06084	E-11	90201-177K7	E- 4	90387-10636	E-10
90159-06110	D- 7	90201-200K3	C-10	90387-113T1	C-14
90159-06123	C- 9	90201-21608	B-13	90387-114K8	C-13
90170-06010	F-10	90202-05180	E-13	90387-124L0	D- 6
90170-06228	C-13		E-15	90387-126T1	D- 6
90170-20327	C- 9	90202-06010	D-13	90387-15550	D-15
90171-16024	E- 4	90202-07015	E-14	90387-170J6	E- 4
90176-06055	E-13	90202-26142	D- 9	90387-171T5	E- 3
90176-22050	D- 9	90206-17084	E-10	90387-171T6	E- 4
90179-05271	E-13	90209-06096	C- 7	90387-202A7	C- 8
90179-05523	E-15	90209-11262	B- 2	90387-203M7	C-10
90179-06500	C- 4	90209-22191	C-10	90387-211T9	C-10
	E-12	90209-25196	C-10	90387-253M6	C-10
90179-08327	B- 4	90214-10047	E-10	90387-253M9	C-10
90179-09489	B- 2	90214-12033	D- 3	90387-271T7	C-10
90179-09490	B- 2	90215-08115	C-13	90387-281T8	C-10
90179-10247	C-14	90215-20231	C- 9	90401-10095	E- 7
90179-18020	C-11	90215-21022	C-10	90401-10096	B-11
90179-25033	D- 9	90240-08013	E-11		E- 7
90183-05024	E-13	90267-40029	E-15		E- 8
90183-08043	D- 2	90267-40087	E-14		E-11
90185-10037	E- 9	90338-09012	E- 7	90401-12122	B-12
90185-14070	D- 6		E- 8	90413-07007	B-14
90201-047A2	E-15	90338-15202	C-14	90430-06014	B- 2
90201-052E2	F- 6	90340-14079	C- 6		B- 3
90201-060K2	B-12	90340-18101	B- 2		B- 8
90201-06059	E-15	90384-18157	D- 8		B-14
90201-062J7	E-12	90387-05383	C- 5	90430-06195	B-12

NUMERICAL INDEX

NUMERICAL INDEX

PART NO.	GRID NO.	PART NO.	GRID NO.	PART NO.	GRID NO.	PART NO.	GRID NO.	PART NO.	GRID NO.	PART NO.	GRID NO.
90430-10188	B-11	90480-18276	B-9	92501-06020	D-7	93210-06632	B-11	93440-45144	C-11	95301-06800	D-12
90430-12202	B-12		F-9	92502-06016	F-11		C-6	93450-19052	B-4	95302-06600	F-9
90445-083A4	F-13	90480-22084	D-4	92506-06012	D-7		C-9	93501-04011	E-9	95302-06700	F-13
90445-096E8	B-9	90480-23192	D-5		D-12		F-8		E-10	95303-06700	C-13
90445-10366	D-13	90480-35394	C-14		E-12	93210-06714	B-11	93511-32027	C-9	95303-08600	E-3
90445-111F8	D-13		E-12	92511-06160	B-14	93210-07135	B-11	93604-10011	B-8	95303-08700	E-11
90445-11153	B-15	90501-06022	C-12	92706-06030	E-13		C-5	93900-00030	D-15	95306-05600	F-6
90445-112E9	B-14	90501-10312	F-10	92901-04600	F-6	93210-08764	B-13		E-3	95306-06600	F-7
90445-112F1	B-14	90501-12743	E-9	92901-05100	F-2	93210-11765	B-11	94580-99110	E-3		F-11
90445-11262	B-15		E-10	92901-05600	F-2	93210-14369	C-6	94581-01110	B-7	95306-12600	F-5
90445-11288	B-14	90501-20422	B-13	92901-06600	D-2	93210-15566	B-13	94681-01021	B-7	95311-08600	D-11
90445-11698	D-13	90501-225A9	C-9	92901-08600	E-3	93210-15620	E-11	94701-00203	B-2	95601-06100	E-9
90446-17267	E-11	90506-18224	E-9	92902-04100	F-6	93210-16629	B-13	94701-00222	B-2		E-11
90450-58016	B-14	90506-26225	E-9	92906-04100	E-11	93210-18417	B-8	95021-06016	B-10	95601-08100	E-11
90460-11149	B-14	90508-10514	C-13		F-6	93210-19216	F-3	95021-08025	E-10	95601-10200	C-14
90460-12256	B-14	90508-20737	E-11	92906-04600	E-11	93210-20573	C-5	95023-06020	B-9		D-6
90460-38241	B-9	90508-26681	C-12		F-6	93210-23692	B-8	95026-06010	B-11		D-8
		90508-32682	C-13		F-10		B-10		B-13		E-3
90462-06158	C-6	90560-06244	D-7	92906-05200	E-12	93210-27194	C-5	95026-06012	B-2	95606-06100	E-8
90464-10075	C-3	90560-12191	C-13		E-13	93210-29196	F-11		B-3		F-9
	F-11	90560-15255	D-15	92906-06100	D-12	93210-30694	B-8		B-8		F-10
90464-16025	C-15	90560-17260	E-3		E-7	93210-33133	B-8		B-11	95611-10100	D-6
90464-23041	B-15	90560-25270	C-9		E-8	93210-40659	B-14		B-12	95611-12100	D-6
90465-08076	B-13	91026-06020	C-13		E-12	93210-49046	B-9		C-6	95701-05500	D-14
90465-08280	C-6	91311-05010	D-13	92906-06600	C-4	93210-77363	B-3		C-15		F-12
90465-08281	C-6	91311-06045	E-9		E-12	93210-87723	B-13		E-15	95701-06500	
90467-08003	B-9		E-10		F-11	93306-00106	B-8		F-3		D-5
90467-09006	D-13	91316-06012	B-8	92906-08100	F-11	93306-00421	C-8	95026-06016	C-8		D-14
90467-10008	B-14	91316-06020	B-12	92906-10200	F-9	93306-20455	C-10		F-11		E-6
90467-10091	D-13		B-14	92990-03100	F-6		C-11	95026-06020	B-8	95701-08500	E-3
90467-11044	D-13	91316-06025	E-7	92990-06100	D-2	93306-20541	C-8		B-9	95701-10500	E-10
90467-14056	C-5		E-8		D-7	93306-30203	D-15		C-7	95706-05500	E-12
90467-14057	E-11	91316-06030	E-7		D-12	93306-30306	E-3	95026-06025	B-2	95706-06500	B-9
90467-15054	C-5	91316-06070	E-6		D-13	93306-30309	E-3		B-7		E-14
90445-106F5	F-11	91316-06080	B-11		E-4	93306-30507	E-3		B-8	95706-12500	F-5
90480-10258	D-3	91316-08030	D-9		E-14	93306-30525	C-10	95026-06030	B-8	95806-06016	E-15
90480-10297	B-9		E-6		F-13	93306-30546	C-10		B-9	95811-06012	C-7
90480-12320	D-4	91401-20015	E-3	92990-06600	B-14	93310-340N8	C-9		B-11	95811-06075	D-12
90480-12475	B-12		E-11		D-13	93317-41761	D-6		B-13	95816-06014	C-7
90480-13383	C-14	91401-30030	E-4	92990-08100	D-11	93317-42060	D-6		C-7	95816-06025	F-11
90480-13398	E-13	91810-08016	B-3	93101-12060	B-8	93317-42550	D-6		C-9	95816-06035	C-5
90480-14074	D-4	91810-18013	B-11	93101-16131	D-6	93332-00008	D-9	95026-06040	B-8	95816-06060	C-5
90480-14182	F-6		C-7	93102-12106	C-13	93332-00023	D-9		C-7	95816-06080	C-5
90480-14229	E-12		C-9	93102-22014	D-15	93340-21505	D-9	95026-06050	B-8	95816-06140	C-5
90480-14323	E-15	92016-06020	E-6	93102-25044	E-3	93399-99919	D-6		C-7	95816-08030	F-2
90480-15259	F-9	92016-08030	E-11	93102-35065	E-3	93440-09141	B-2	95026-06090	C-9	95816-08045	C-5
90480-16233	D-4	92501-06010	C-7	93102-35109	C-10	93440-25084	C-10	95026-08025	E-12	95816-08055	C-5
90480-18171	B-15	92501-06012	B-14	93105-45017	D-15	93440-28062	C-10	95026-08040	E-12	95816-08065	C-5
		92501-06020	C-7	93109-12053	C-13						

NUMERICAL INDEX

PART NO.	GRID NO.	PART NO.	GRID NO.	PART NO.	GRID NO.
95816-08090	C- 5				
95816-08135	C- 5				
95821-06016	B-12				
95822-06016	C-12				
95826-06012	E-12				
95826-06020	B- 9				
97001-06020	D- 2				
97001-06025	D-12				
97002-06016	D-13				
97006-06012	E-12				
97006-06065	F-11				
97301-06010	E- 4				
	E-14				
37313-06016	D- 2				
97313-08030	D-12				
97326-08012	F-11				
97706-40616	F- 8				
97706-40620	F- 5				
97706-50614	E-12				
	E-13				
97706-60114	B- 9				
98501-03010	F- 6				
98501-03012	F- 6				
98501-05010	C- 2				
	C- 3				
98501-05018	F- 2				
98501-05035	F-10				
98503-04014	C- 2				
98506-04008	F- 6				
98506-04012	E-11				
98506-04018	F-10				
98506-05008	E- 6				
98506-05040	F-10				
98506-05045	F-10				
98511-04016	C- 3				
98580-04010	F- 6				
98701-05012	C-12				
98706-04012	E- 7				
	E- 8				
98901-06008	B-13				
98902-05012	D-13				
98903-06012	D-13				
99001-10600	C-13				
99009-12400	B- 8				
99510-08016	B- 2				
	B-13				
99530-10014	B- 2				
	C- 5				

