

YAMAHA



**PARTS
CATALOGUE**

FZR1000'94 (3GME/3LE6/3LG6)
EUROPE (3LH6/3GMF/4PM1)

FZR1000F (3LJ6)
OCEANIA

YAMAHA
GENUINE
Parts & Accessories

143GM-300E1

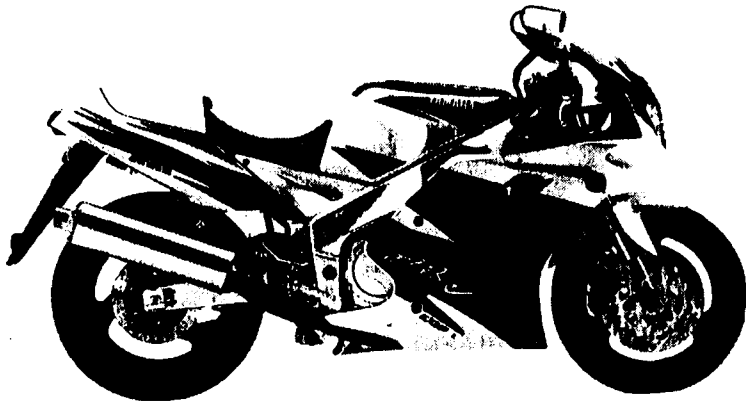

BLUISH WHITE COCKTAIL 1 (0390)

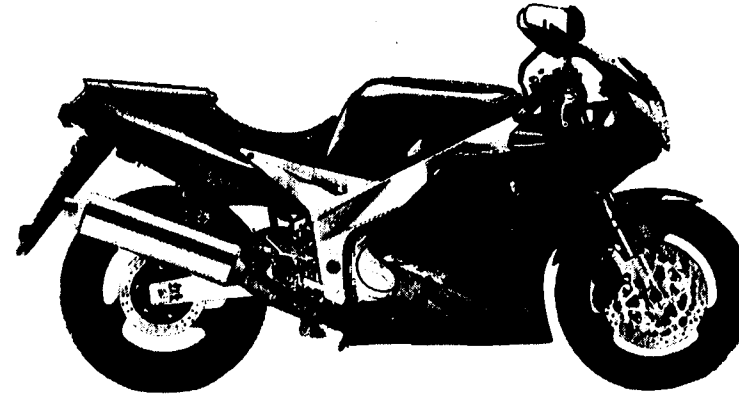

BLACK 2 (004B)

A3

FOREWORD

This Parts Catalogue is related to the parts for the model(s) in the below frame. When you are ordering replacement parts, please refer to this Parts Catalogue and quote both part numbers and part names correctly.

FZR1000'94 (3GME/3LE6/3LG6/3LH6/3GMF/4PM1) FZR1000F (3LJ6)

1. Modifications or additions which have been made after issue of the Parts Catalogue will be announced in the Yamaha Parts News. It is advisable that you make necessary corrections to the Parts Catalogue according to the Yamaha Parts News.

2. Abbreviations

The following abbreviations are used in this Parts Catalogue.

- "UR" Use specified parts number.
- "UN" Use as many as needed.
- "AP" Alternate Parts
- "LM" Local Made (Parts need to be ordered locally)
- "F#" Frame No. (Applicable machine No.)

3. Parts, which are to be supplied in an assembly, are listed with a dot (.) in front of the part name as shown below.

EXAMPLE

CARBURETOR ASSY
 . JET, PILOT
 . NOZZLE, MAIN

4. Number of component for assembly
 The numeral appearing to the right of each component part indicates the quantity of parts for each assembly unit.

EXAMPLE

PART NO.	DESCRIPTION	Q'TY	REMARKS
2F5-83310-60	FRONT FLASHER LIGHT ASSY	2	
115-83311-60	. BULB (6V-18W)	1	

5. Applicable colors of graphics are represented in the "REMARKS" as shown below.

PART NO.	DESCRIPTION	Q'TY	REMARKS
2N4-24110-00-XS	FUEL TANK COMP.	1	MAXIM RED
3J1-24240-10	. GRAPHIC, FUEL TANK	1	for MXR

6. Applicable Serial No. and Color Code

3GME	① Frame Serial No.	3GM-49101	~
	② Engine Serial No.	3GM-49101	~
3LE6	① Frame Serial No.	3LE-038101	~
	② Engine Serial No.	3LE-038101	~
3LG6	① Frame Serial No.	3LG-019101	~
	② Engine Serial No.	3LG-019101	~
3LH6	① Frame Serial No.	3LH-019101	~
	② Engine Serial No.	3LH-019101	~
3GMF	① Frame Serial No.	3GM-055101	~
	② Engine Serial No.	3GM-055101	~
3LJ6	① Frame Serial No.	3LJ-007101	~
	② Engine Serial No.	3LJ-007101	~
4PM1	① Frame Serial No.	3GM-057101	~
	② Engine Serial No.	4PM-057101	~

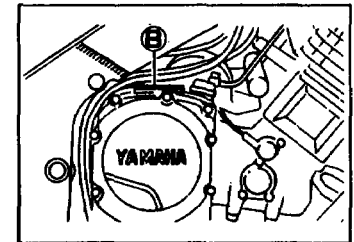
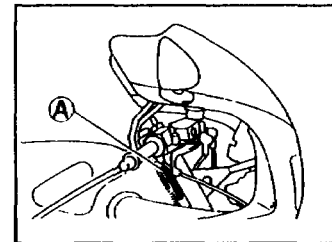

Color Code	Color Name	Abbreviation
0390	BLUISH WHITE COCKTAILE 1	BWC 1
004B	BLACK 2	BL 2

7. Note that the illustrations are for reference in finding parts numbers, not to be used for assembling. When assembling, please use the applicable service manual.
8. The asterisk (*) before a reference number indicates modification items after the first edition.

A4

GENERAL SPEC.

CONTENTS

GENERAL SPEC. ENGINE

Cylinder Head	B2
Cylinder	B3
Crankshaft · Piston	B4
Valve	B5 ~ B6
Camshaft · Chain	B7
Water Pump	B8
Radiator · Hose	B9
Oil Pump	B10 ~ B11
Oil Cleaner	B12
Intake	B13 ~ B14
Carburetor	B15 ~ C3
Exhaust	C4
Crankcase	C5 ~ C6
Crankcase Cover 1	C7 ~ C8
Starter	C9
Clutch	C10
Transmission	C11 ~ C12
Shift Cam · Fork	C13
Shift Shaft	C14

CHASSIS

Frame	C15 ~ D2
Fender	D3 ~ D4
Side Cover	D5
Side Cover 2	D6
Rear Arm	D7 ~ D8

Rear Suspension	D9
Steering	D10
Front Fork	D11 ~ D12
Fuel Tank	D13 ~ D14
Seat	D15
Front Wheel	E2
Front Brake Caliper	E3
Rear Wheel	E4 ~ E5
Rear Brake Caliper	E6
Steering Handle · Cable	E7
Front Master Cylinder	E8 ~ E9
Front Master Cylinder 2	E10
Stand · Footrest	E11 ~ E12
Rear Master Cylinder	E13
Cowling 1	E14 ~ E15
Cowling 2	F2
Cowling 3	F3
Generator	F4
Pick Up Coil · Governor	F5
Starting Motor	F6
Flasher Light	F7
Meter	F8
Headlight	F9
Taillight	F10
Electrical 1	F11 ~ F12
Electrical 2	F13 ~ F14

INDIVIDUAL SPEC. FOR FINLAND/SWEDEN

Alternate (Caburetor)	G2 ~ G4
Alternate (Engine)	G5
Alternate (Electrical)	G6

FOR AUSTRIA

Alternate (Caburator)	G8 ~ G10
Alternate (Chassis)	G11

FOR SWITZERLAND

Alternate (Caburetor)	G13 ~ G15
Alternate (Electrical)	H2

FOR ENGLAND

Alternate (Engine)	H4
Alternate (Headlight)	H5

FOR HOLLAND

Alternate (Headlight)	H7
-----------------------------	----

FOR ITALY

Alternate (Headlight)	H9
-----------------------------	----

FOR OCEANIA

Alternate (Headlight)	H11
-----------------------------	-----

INDEX

NUMERICAL INDEX	L1 ~ L5
-----------------------	---------

FIG. 1 CYLINDER HEAD

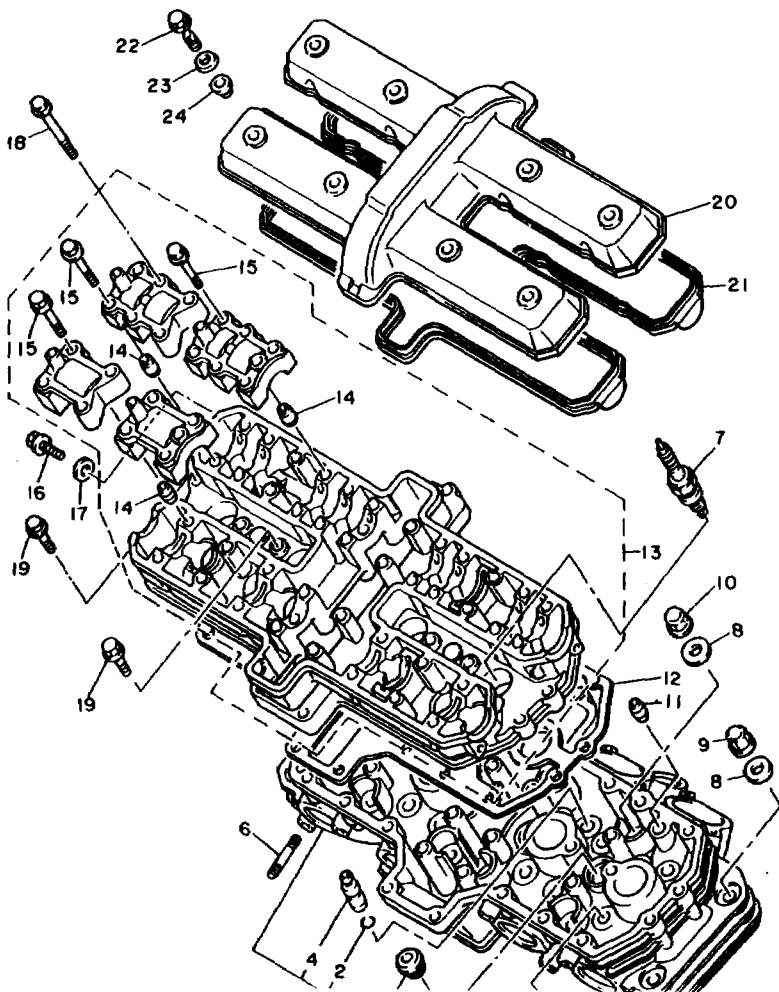

REF. NO.	PART NO.	DESCRIPTION	Q'TY	REMARKS
1	3GM-11102-00	CYLINDER HEAD ASSY	1	
2	93440-10153	.CIRCLIP	20	
3	90340-18101	.PLUG, STRAIGHT SCREW	4	
4	3GM-11133-10	.GUIDE, INTAKE VALVE	12	
5	3GM-11134-10	.GUIDE, EXHAUST VALVE	8	
6	95611-08825	BOLT, STUD	8	
7	94701-00333	PLUG, SPARK (NGK DR8EA)	4	UR
	94701-00222	PLUG, SPARK (ND X24ESR-U)	4	UR
8	90201-103M4	WASHER, PLATE	12	
9	90176-10049	NUT, CROWN	4	
10	90179-10584	NUT	8	
11	99530-10014	PIN, DOWEL	2	
12	3GM-11182-00	GASKET, CYLINDER HEAD 2	1	
13	3GM-1115A-00	CAM CASE ASSY	1	
14	99510-08016	.PIN, DOWEL	16	
15	90105-06153	.BOLT, WASHER BASED	16	
16	95023-06012	BOLT	1	
17	90430-06014	GASKET	1	
18	90105-06541	BOLT, WASHER BASED	24	
19	95023-06025	BOLT	11	
20	3GM-11191-00	COVER, CYLINDER HEAD 1	1	
21	3GM-11193-00	GASKET, HEAD COVER 1	1	
22	90109-084F0	BOLT	8	
23	90209-11262	WASHER	8	
24	2GH-1111G-00	RUBBER, MOUNT 1	8	

FIG. 2 CYLINDER

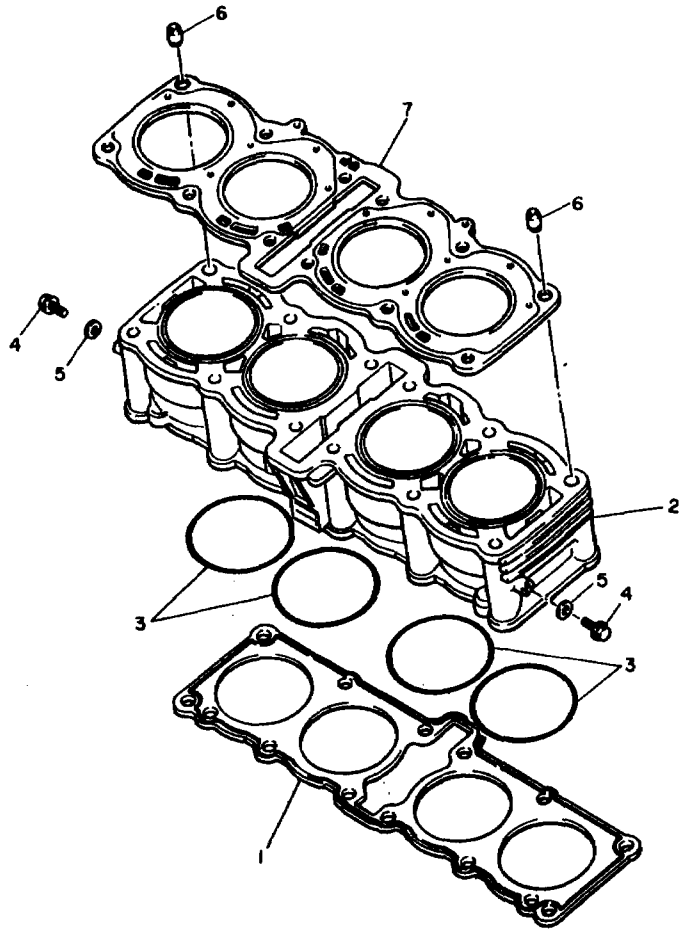

REF. NO.	PART NO.	DESCRIPTION	QTY	REMARKS
1	3GM-11351-00	GASKET, CYLINDER	1	
2	3GM-11310-00	CYLINDER	1	UR
	4PM-11310-00	CYLINDER	1	UR FOR ITALY
3	93210-77363	O-RING	4	
4	95023-08012	BOLT	2	
5	90430-08014	GASKET	2	
6	99510-14016	PIN, DOWEL	2	
7	3GM-11181-00	GASKET, CYLINDER HEAD 1	1	

3LE332-9020

B3

FIG. 3 CRANKSHAFT • PISTON

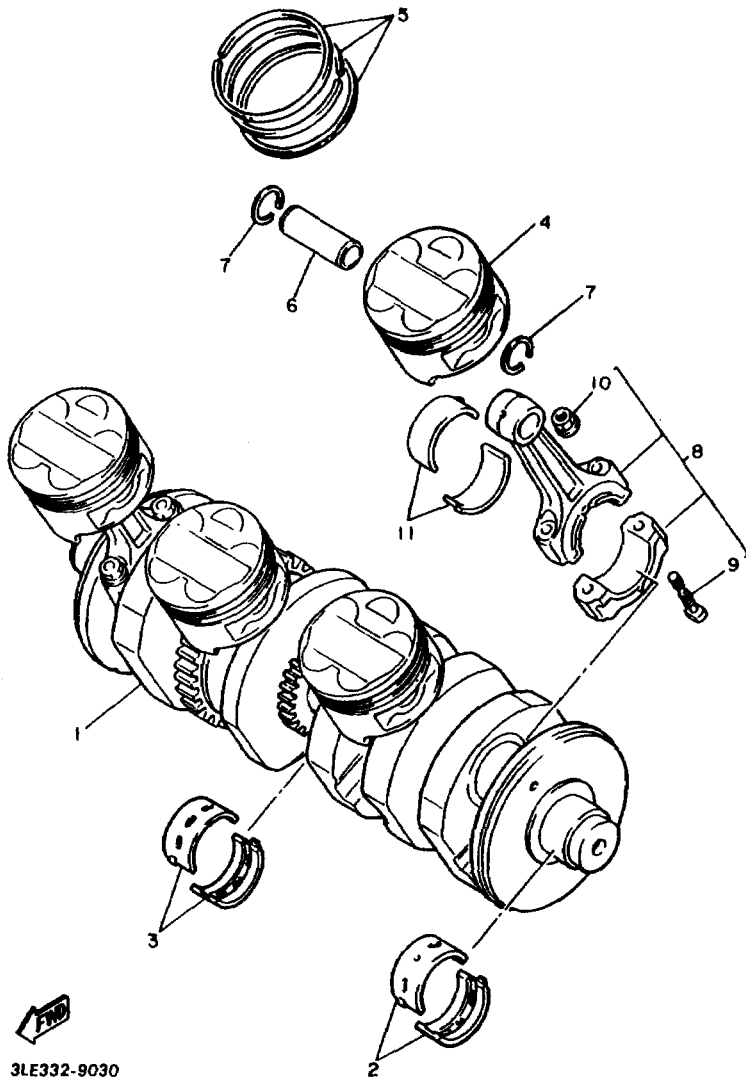

3LE332-9030

REF. NO.	PART NO.	DESCRIPTION	Q'TY	REMARKS
1	3GM-11411-01	CRANKSHAFT	1	
2	2GH-11416-00	PLANE BEARING, CRANKSHAFT 1	8	UR BLUE
	2GH-11416-10	PLANE BEARING, CRANKSHAFT 1	8	UR BLACK
	2GH-11416-20	PLANE BEARING, CRANKSHAFT 1	8	UR BROWN
	2GH-11416-30	PLANE BEARING, CRANKSHAFT 1	8	UR GREEN
	2GH-11416-40	PLANE BEARING, CRANKSHAFT 1	8	UR YELLOW
3	3GM-11416-00	PLANE BEARING, CRANKSHAFT 1	2	UR BLUE
	3GM-11416-10	PLANE BEARING, CRANKSHAFT 1	2	UR BLACK
	3GM-11416-20	PLANE BEARING, CRANKSHAFT 1	2	UR BROWN
	3GM-11416-30	PLANE BEARING, CRANKSHAFT 1	2	UR GREEN
	3GM-11416-40	PLANE BEARING, CRANKSHAFT 1	2	UR YELLOW
4	3GM-11631-00	PISTON (STD)	4	
	3GM-11636-00	PISTON (0.50MM O/S)	4	AP
5	3GM-11610-00	PISTON RING SET (STD)	4	
	3GM-11610-20	PISTON RING SET (0.50MM O/S)	4	AP
6	3GM-11633-00	PIN, PISTON	4	
7	93450-19095	CIRCLIP	8	
8	3GM-11650-01	CONNECTING ROD ASSY	4	
9	12R-11654-00	.BOLT, CONNECTING ROD	2	
10	90179-08327	.NUT	2	
11	3GM-11656-00	PLANE BEARING, CONNECTING ROD	8	UR BLUE
	3GM-11656-10	PLANE BEARING, CONNECTING ROD	8	UR BLACK
	3GM-11656-20	PLANE BEARING, CONNECTING ROD	8	UR BROWN
	3GM-11656-30	PLANE BEARING, CONNECTING ROD	8	UR GREEN

FIG. 4 VALVE

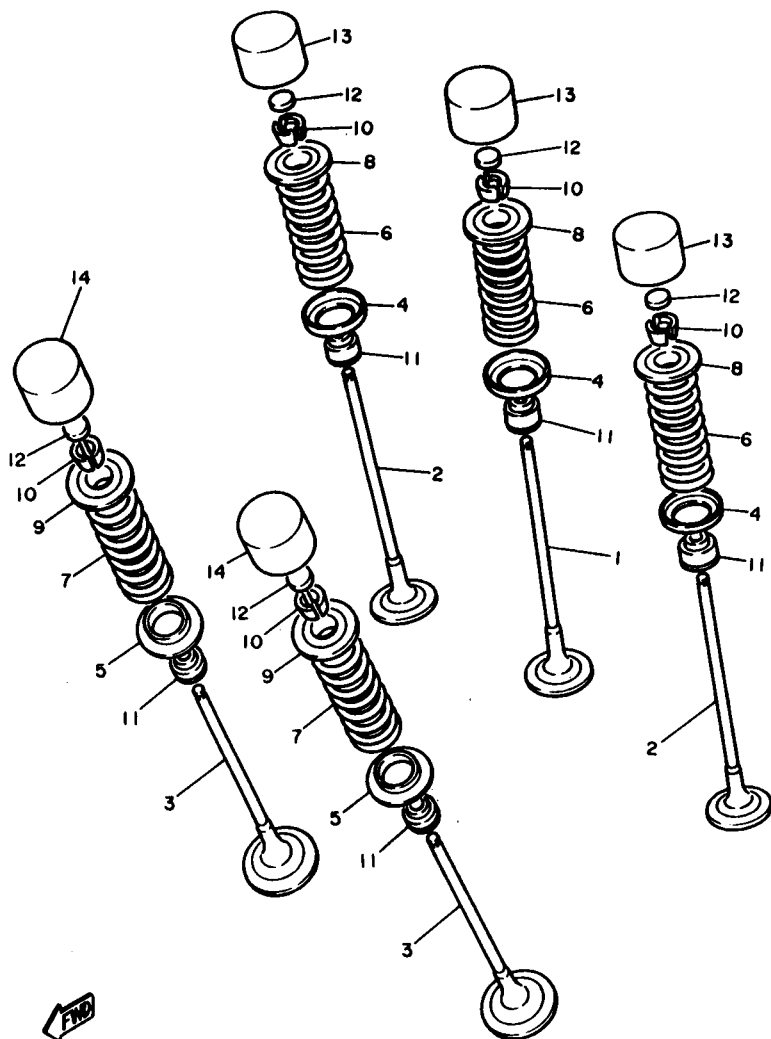

3LE332-9040

REF. NO.	PART NO.	DESCRIPTION	Q'TY	REMARKS
1	3GM-12111-00	VALVE, INTAKE	4	
2	3GM-12112-00	VALVE, INTAKE 2	8	
3	3GM-12121-00	VALVE, EXHAUST	8	
4	3GM-12116-00	SEAT, VALVE SPRING	12	
5	3GM-12126-00	SEAT, VALVE SPRING 2	8	
6	3GM-12113-00	SPRING, VALVE INNER	12	
7	3GM-12114-00	SPRING, VALVE OUTER	8	
8	3GM-12117-00	RETAINER, VALVE SPRING	12	
9	1WG-12117-00	RETAINER, VALVE SPRING	8	
10	1WG-12118-00	COTTER, VALVE	40	
11	1WG-12119-00	SEAL, VALVE STEM	20	
12	1HX-12168-00	PAD, ADJUSTING 2 (1.20)	20	UR
	1HX-12168-20	PAD, ADJUSTING 2 (1.25)	20	UR
	1HX-12168-40	PAD, ADJUSTING 2 (1.30)	20	UR
	1HX-12168-60	PAD, ADJUSTING 2 (1.35)	20	UR
	1HX-12168-80	PAD, ADJUSTING 2 (1.40)	20	UR
	1HX-12168-A0	PAD, ADJUSTING 2 (1.45)	20	UR
	1HX-12168-F0	PAD, ADJUSTING 2 (1.50)	20	UR
	1HX-12168-H1	PAD, ADJUSTING 2 (1.55)	20	UR
	1HX-12168-K1	PAD, ADJUSTING 2 (1.60)	20	UR
	1HX-12168-M1	PAD, ADJUSTING 2 (1.65)	20	UR
	1HX-12168-R1	PAD, ADJUSTING 2 (1.70)	20	UR
	1HX-12168-U1	PAD, ADJUSTING 2 (1.75)	20	UR
	1HX-12168-W1	PAD, ADJUSTING 2 (1.80)	20	UR
	1HX-12168-Y1	PAD, ADJUSTING 2 (1.85)	20	UR
	1HX-12169-11	PAD, ADJUSTING 2 (1.90)	20	UR
	1HX-12169-31	PAD, ADJUSTING 2 (1.95)	20	UR
	1HX-12169-50	PAD, ADJUSTING 2 (2.00)	20	UR

FIG. 4 VALVE

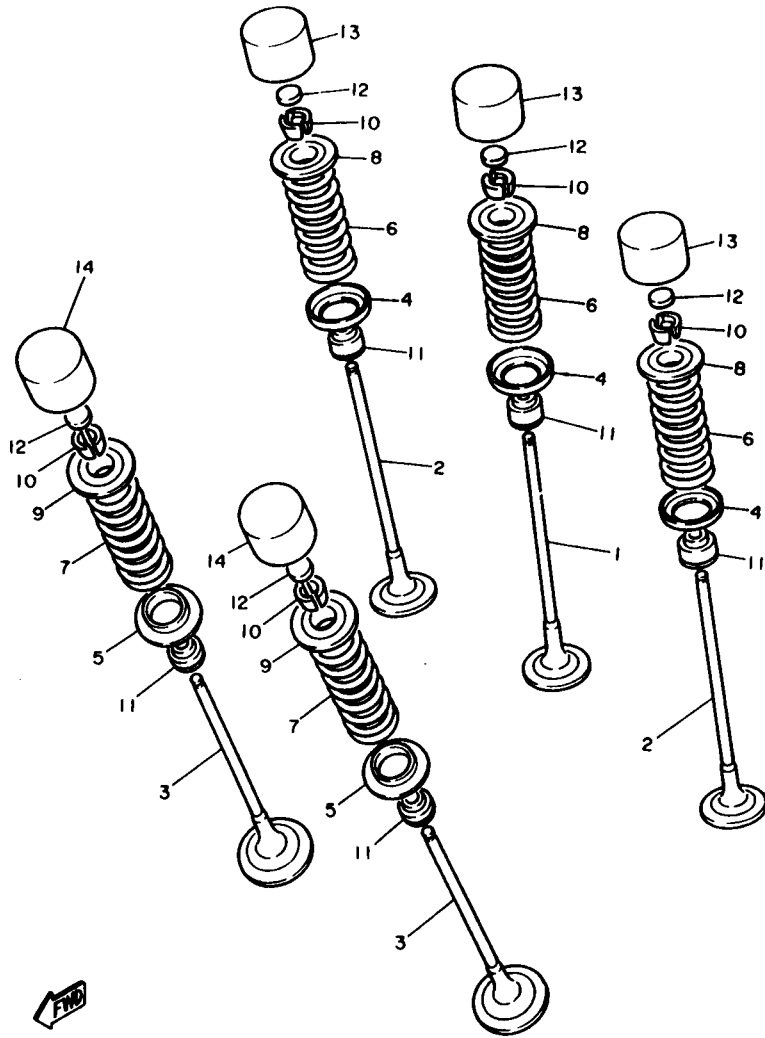

REF. NO.	PART NO.	DESCRIPTION	Q'TY	REMARKS	
12	1HX-12189-70	PAD, ADJUSTING 2 (2.05)	20	UR	
	1HX-12189-90	PAD, ADJUSTING 2 (2.10)	20	UR	
	1HX-12189-E0	PAD, ADJUSTING 2 (2.15)	20	UR	
	1HX-12189-G0	PAD, ADJUSTING 2 (2.20)	20	UR	
	1HX-12189-J0	PAD, ADJUSTING 2 (2.25)	20	UR	
	1HX-12189-L0	PAD, ADJUSTING 2 (2.30)	20	UR	
	1HX-12189-N0	PAD, ADJUSTING 2 (2.35)	20	UR	
	1HX-12189-T0	PAD, ADJUSTING 2 (2.40)	20	UR	
	13	2NK-12153-02	LIFTER, VALVE	12	UR BLACK
		2NK-12153-09	LIFTER, VALVE (O/S)	12	UR WHITE
14	1WG-12153-21	LIFTER, VALVE.	8	UR BLUE	
	1WG-12153-09	LIFTER, VALVE (O/S)	8	UR WHITE	



3LE332-9040

B6

FIG. 5 CAMSHAFT . CHAIN

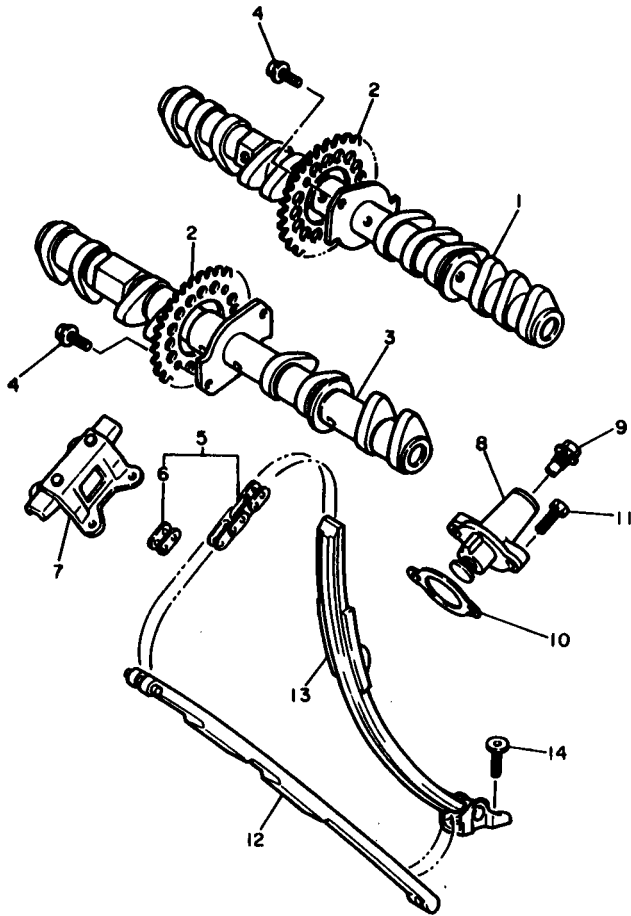

REF. NO.	PART NO.	DESCRIPTION	Q'TY	REMARKS
1	3GM-12171-00	CAMSHAFT 1	1	
2	3GM-12176-00	SPROCKET, CAM CHAIN	2	
3	3GM-12181-00	CAMSHAFT 2	1	
4	90105-07342	BOLT, WASHER BASED	4	
5	94581-01108	CHAIN (DID219FS-108L)	1	
6	94681-01021	JOINT, CHAIN	1	
7	2GH-12241-00	GUIDE, STOPPER 2	1	
8	3GM-12210-00	TENSIONER ASSY, CAM CHAIN	1	
9	90109-112F1	BOLT	1	
10	4BE-12213-00	GASKET, TENSIONER CASE	1	
11	95023-06025	BOLT	2	
12	3GM-12251-00	DAMPER, CHAIN 1	1	
13	3GM-12252-00	DAMPER, CHAIN 2	1	
14	90109-085A8	BOLT	2	



3LE332-9060

B7

FIG. 7 RADIATOR . HOSE

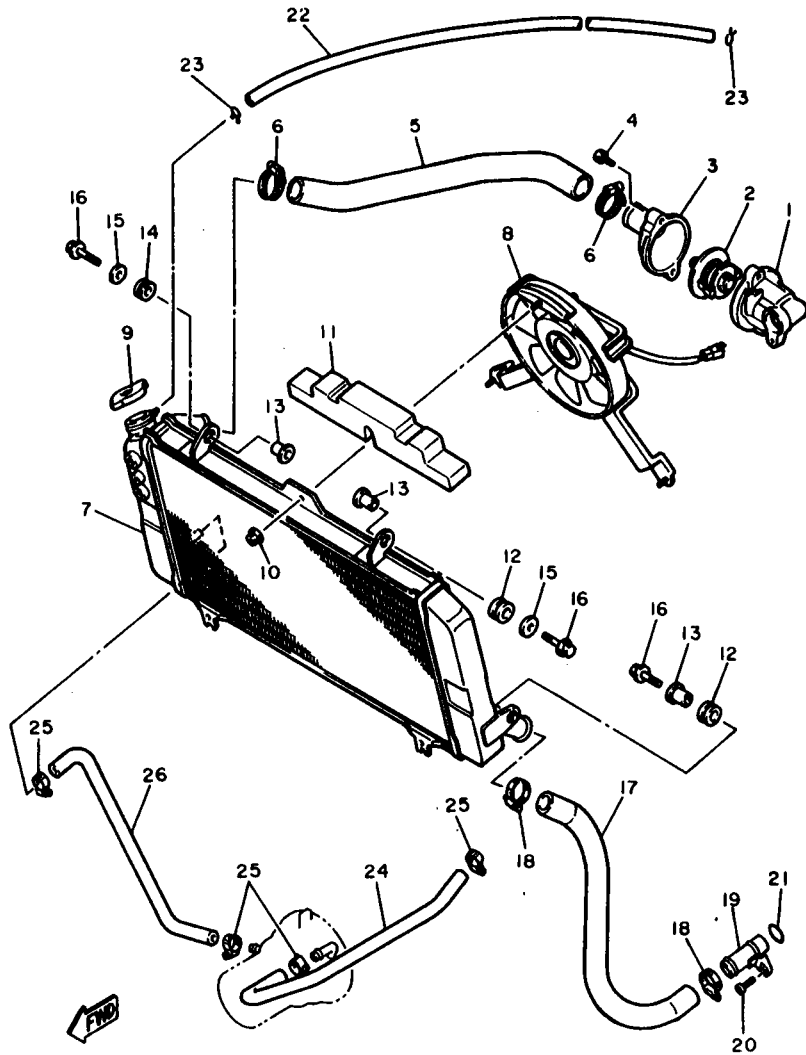

3LE332-1070

REF. NO.	PART NO.	DESCRIPTION	Q'TY	REMARKS
1	3GM-12417-00	HOUSING, THERMOSTAT	1	
2	3GM-12410-00	THERMOSTAT ASSY	1	
3	3GM-12413-00	COVER, THERMOSTAT	1	
4	95023-08025	BOLT	2	
5	3GM-12576-50	HOSE 1	1	
6	90450-38040	HOSE CLAMP ASSY	2	
7	3GM-12461-50	RADIATOR ASSY	1	
8	3GM-12405-50	BLOWER ASSY	1	
9	22W-12462-00	CAP, RADIATOR	1	
10	95706-06500	NUT, FLANGE	3	
11	3GM-12882-50	PROTECTOR, HEAT	1	
12	90480-15363	GROMMET	3	
13	90387-07391	COLLAR	4	
14	90480-10297	GROMMET	1	
15	90201-063J2	WASHER, PLATE	2	
16	95816-08025	BOLT, FLANGE	4	
17	3GM-12579-50	HOSE 4	1	
18	90450-38040	HOSE CLAMP ASSY	2	
19	2GH-12484-00	PIPE 4	1	
20	90110-06142	BOLT, HEXAGON SOCKET HEAD	1	
21	93210-23787	O-RING	1	
22	90445-096E8	HOSE	1	
23	90467-08003	CLIP	2	
24	3GM-12588-50	HOSE 5	1	
25	90450-22052	HOSE CLAMP ASSY	4	
26	3GM-12589-50	HOSE 6	1	

B9

FIG. 6 WATER PUMP

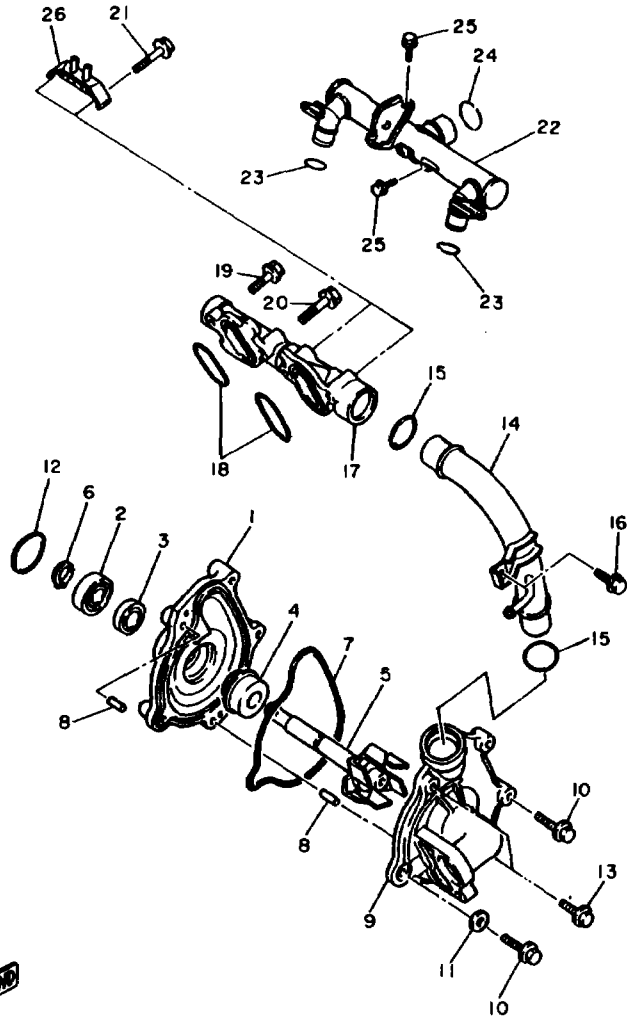

REF. NO.	PART NO.	DESCRIPTION	QTY	REMARKS
1	1UF-12421-09	HOUSING, WATER PUMP	1	
2	93308-00108	BEARING	1	
3	93101-12080	OIL SEAL	1	
4	11H-12438-00	SEAL, MECHANICAL	1	
5	1UF-12460-00	IMPELLER SHAFT ASSY	1	
6	99009-12400	CIRCLIP	1	
7	1AE-12439-00	O-RING	1	
8	93804-10011	PIN, DOWEL	2	
9	3GM-12422-00	COVER, HOUSING	1	
10	95023-08025	BOLT	3	
11	90430-08014	GASKET	1	
12	93210-33133	O-RING	1	
13	95021-08060	BOLT, FLANGE	2	
14	4BH-12481-01	PIPE 1	1	
15	93210-23787	O-RING	2	
16	95023-08012	BOLT	1	
17	3DX-12469-00	JOINT 1	1	
18	93210-30694	O-RING	2	
19	95023-08020	BOLT	1	
20	95023-08030	BOLT	1	
21	95023-08040	BOLT	2	
22	3GM-12482-00	PIPE 2	1	
23	93210-18417	O-RING	2	
24	93210-23787	O-RING	1	
25	95023-08010	BOLT	2	
26	2GH-14413-00	STAY	1	



3LE332-1060

B8

FIG. 8 OIL PUMP

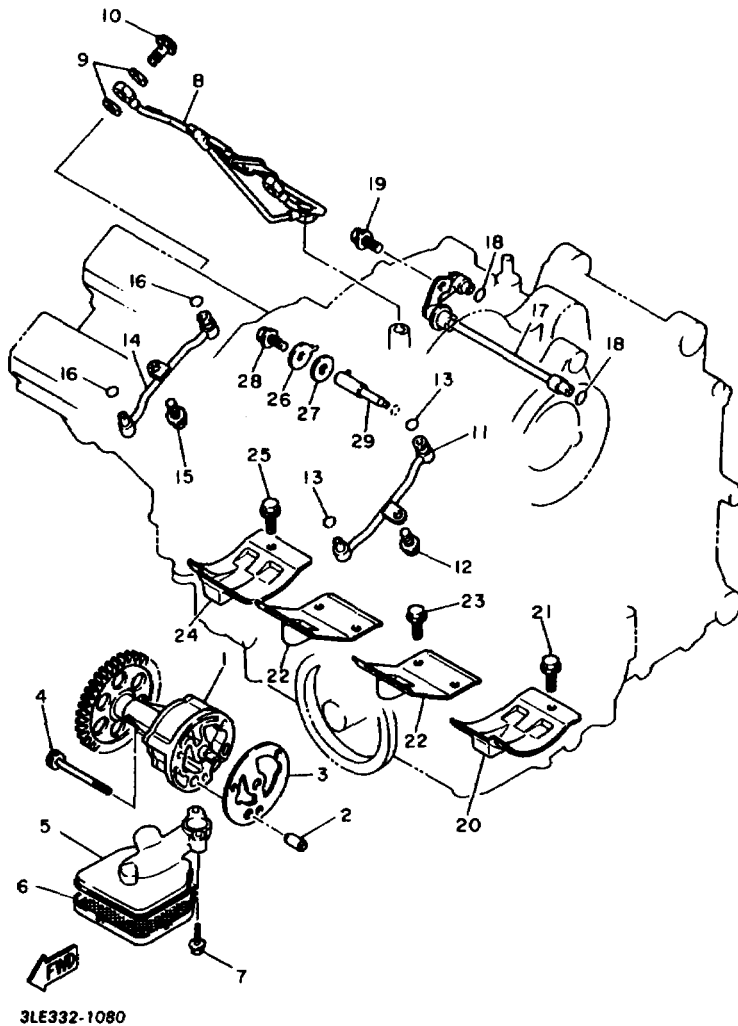

REF. NO.	PART NO.	DESCRIPTION	Q'TY	REMARKS
1	1AE-13300-00	OIL PUMP ASSY	1	
2	99510-08012	PIN, DOWEL	1	
3	2GH-13329-00	GASKET, PUMP COVER	1	
4	91316-06050	BOLT	3	
5	3GM-13412-50	HOUSING, STRAINER	1	
6	3GM-13411-00	STRAINER, OIL	1	
7	95026-06030	BOLT, FLANGE	2	
8	3GM-13171-00	PIPE, DELIVERY 2	1	
9	90430-10171	GASKET	6	
10	90401-10139	BOLT, UNION	3	
11	3GM-13181-00	PIPE, DELIVERY 3	1	
12	95026-08012	BOLT, FLANGE	1	
13	93210-06632	O-RING	2	
14	3GM-13191-00	PIPE, DELIVERY 4	1	
15	95026-06012	BOLT, FLANGE	1	
16	93210-06632	O-RING	2	
17	2GH-1318E-00	PIPE, DELEVERY 5	1	
18	93210-07135	O-RING	2	
19	95026-06012	BOLT, FLANGE	1	
20	2GH-15123-00	PLATE, BUFFLE 1	1	
21	95026-06012	BOLT, FLANGE	2	
22	1AE-15124-00	PLATE, BUFFLE 2	2	
23	95026-06012	BOLT, FLANGE	6	
24	2GH-15133-00	PLATE, BUFFLE 3	1	
25	95026-06012	BOLT, FLANGE	2	
26	90201-061M7	WASHER, PLATE	1	
27	4BH-13475-00	GASKET	1	
28	95811-06016	BOLT, FLANGE	1	

FIG. 8 OIL PUMP

REF. NO.	PART NO.	DESCRIPTION	Q'TY	REMARKS
29	3GM-13454-00	NOZZLE	1	

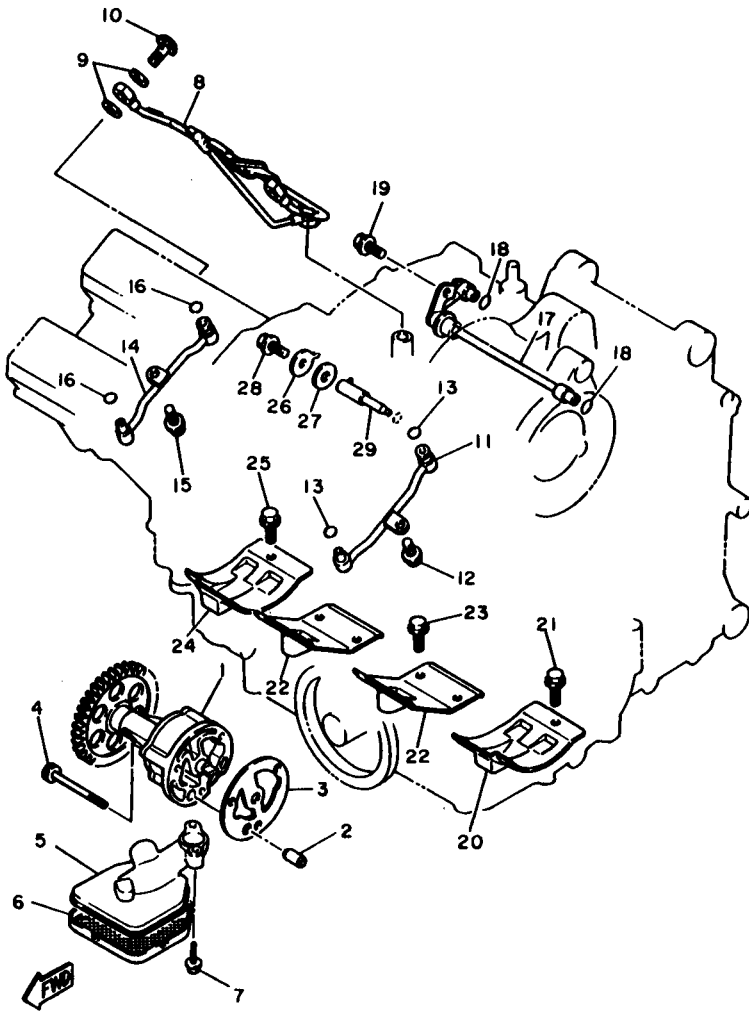

3LE332-1080

B11

FIG. 9 OIL CLEANER

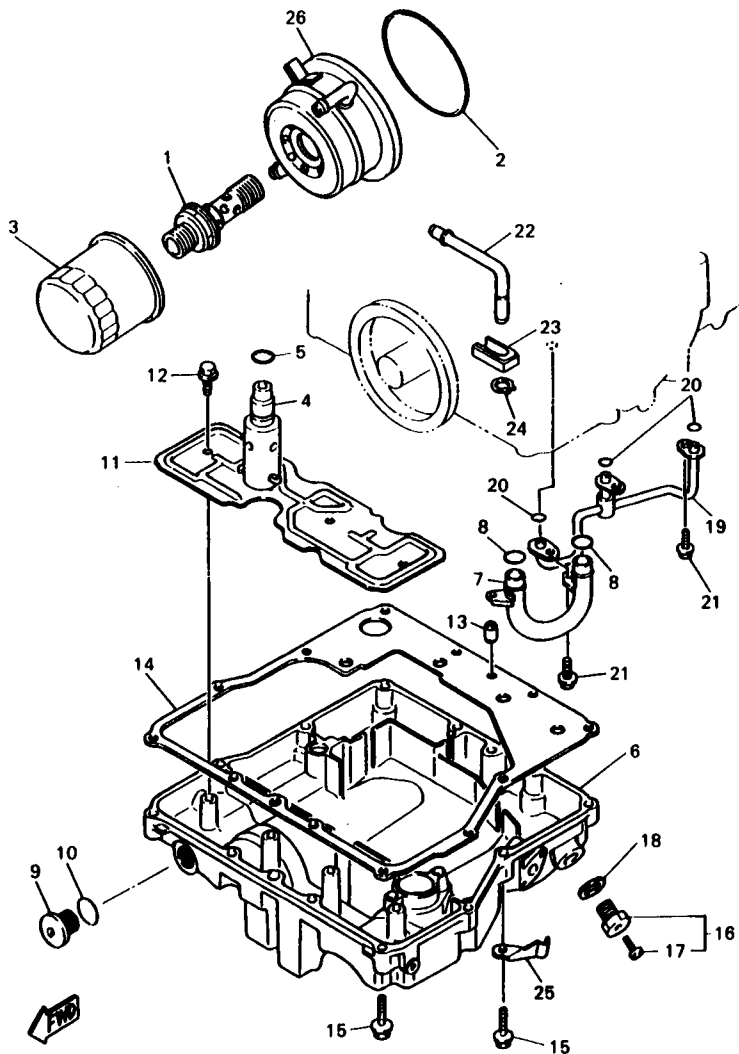

3LE332-4090

REF. NO.	PART NO.	DESCRIPTION	Q'TY	REMARKS
1	90401-20158	BOLT, UNION	1	
2	93210-87723	O-RING	1	
3	3FV-13440-00	ELEMENT ASSY, OIL CLEANER	1	
4	3KS-13490-00	RELIEF VALVE ASSY	1	
5	93210-15586	O-RING	1	
6	3GM-13417-50	COVER, STRAINER	1	
7	3FV-13416-01	PIPE, OIL 1	1	
8	93210-14579	O-RING	2	
9	38Y-15189-00	PLUG	1	
10	93210-16629	O-RING	1	
11	3GM-13337-00	PLATE, BAFFLE LOWER	1	
12	95026-06010	BOLT, FLANGE	4	
13	99510-08016	PIN, DOWEL	2	
14	4BH-13414-00	GASKET, STRAINER COVER	1	
15	95023-06030	BOLT	12	
16	3VD-13455-00	PLUG	1	
17	98901-06008	.SCREW, BIND	1	
18	214-11198-01	GASKET	1	
19	3GM-13161-01	PIPE, DELIVERY 1	1	
20	93210-06714	O-RING	3	
21	95026-06012	BOLT, FLANGE	3	
22	3GM-15373-00	PIPE, BREATHER	1	
23	3GM-13174-00	HOLDER, OIL PIPE	1	
24	99009-10400	CIRCLIP	1	
25	90485-08076	CLAMP	1	
26	3TJ-13470-00	OIL COOLER ASSY	1	

FIG. 10 INTAKE

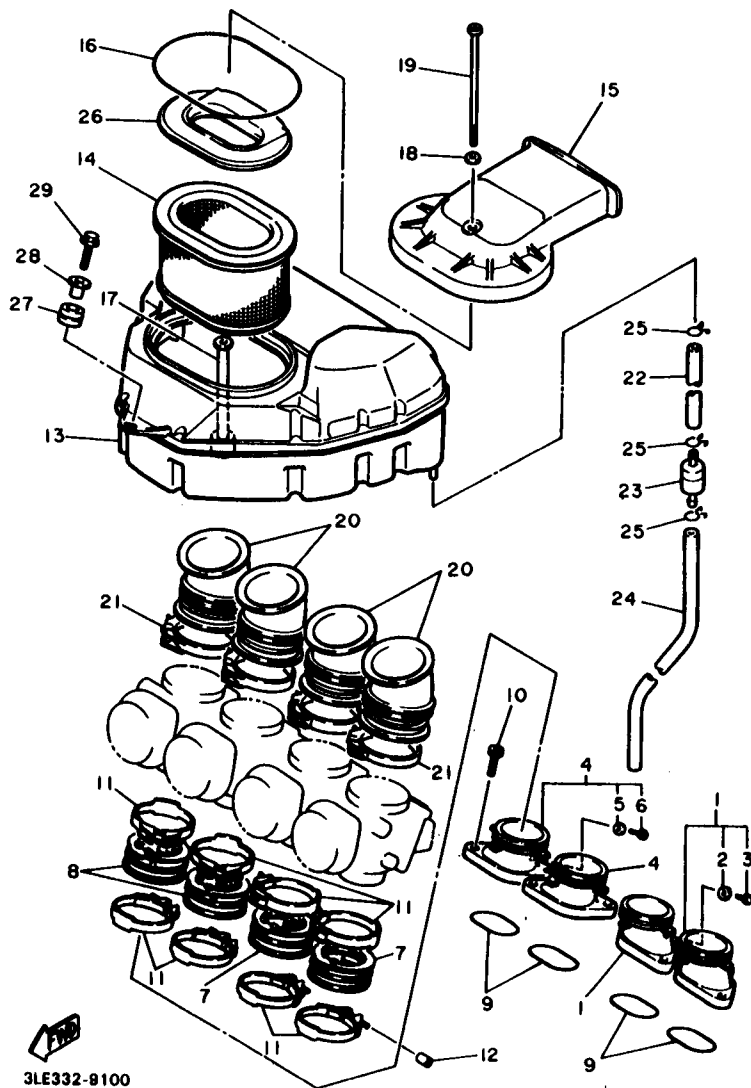

REF. NO.	PART NO.	DESCRIPTION	Q'TY	REMARKS
1	3GM-13586-00	JOINT, CARBURETOR 1	2	
2	90430-06014	.GASKET	1	
3	91312-06012	.BOLT	1	
4	3GM-13596-00	JOINT, CARBURETOR 2	2	
5	90430-06014	.GASKET	1	
6	91312-06012	.BOLT	1	
7	3GM-13597-00	JOINT, CARBURETOR 3	2	
8	3GM-13598-00	JOINT, CARBURETOR 4	2	
9	93210-44545	O-RING	4	
10	91316-08020	BOLT	8	
11	90450-67034	HOSE CLAMP ASSY	8	
12	90445-08740	HOSE	2	
13	3GM-14401-00	AIR CLEANER CASE ASSY	1	
14	3GM-14451-00	ELEMENT, AIR CLEANER	1	
15	3GM-14422-00	CAP, CLEANER CASE 2	1	
16	36F-14452-00	SEAL	1	
17	3GM-14443-00	COLLAR	1	
18	92990-06600	WASHER, PLATE	1	
19	98511-08140	SCREW, PAN HEAD	1	
20	3GM-14453-00	JOINT, AIR CLEANER 1	4	
21	90450-67066	HOSE CLAMP ASSY	4	
22	90445-11288	HOSE	1	
23	4X7-2149Y-00	FILTER ASSY	1	
24	90445-114E2	HOSE	1	
25	90467-10008	CLIP	3	
26	3GM-14432-00	SILENCER, INNER	1	
27	90480-14023	GROMMET	1	
28	90387-080M9	COLLAR	1	

FIG. 10 INTAKE

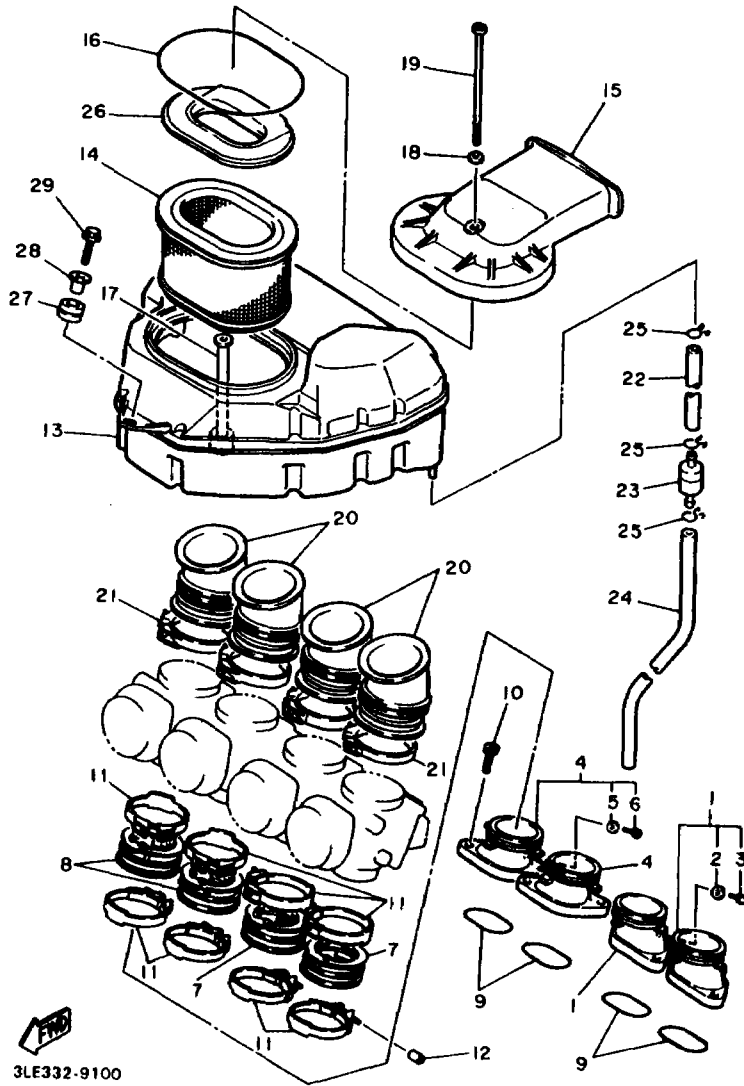

REF. NO.	PART NO.	DESCRIPTION	Q'TY	REMARKS
29	96811-08030	BOLT, FLANGE	1	

3LE332-9100

FIG. 11 CARBURETOR

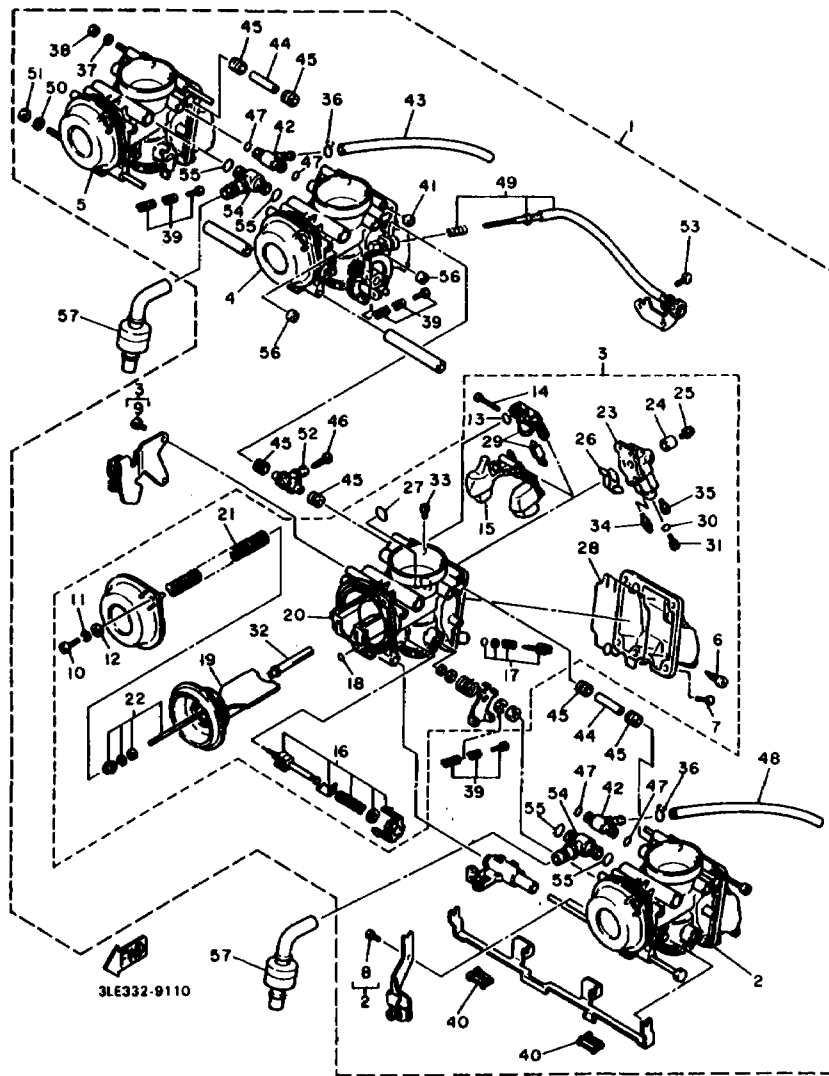

REF. NO.	PART NO.	DESCRIPTION	Q'TY	REMARKS
1	3GM-14900-00	CARBURETOR ASSY	1	
2	3GM-14901-00	..CARBURETOR ASSY 1	1	
3	3GM-14902-00	..CARBURETOR ASSY 2	1	
4	3GM-14903-00	..CARBURETOR ASSY 3	1	
5	3GM-14904-00	..CARBURETOR ASSY 4	1	
6	12R-14191-00	..PLUG, DRAIN	1	
7	98501-06012	..SCREW, PAN HEAD	4	
8	98580-04008	..SCREW, PAN HEAD	1	
9	98580-04008	..SCREW, PAN HEAD	2	
10	98586-06016	..SCREW, PAN HEAD	2	
11	92906-06100	..WASHER, SPRING	2	
12	92906-06600	..WASHER, PLATE	2	
13	3EN-14147-00	..O-RING	1	
14	63L-14186-00	..PIN, FLOAT	1	
15	3GM-14985-00	..FLOAT	1	
16	3EN-1410A-00	..STARTER SET	1	
17	12R-14106-00	..PILOT SCREW SET	1	
18	3FV-14147-00	..O-RING	1	
19	3GM-14940-00	..DIAPHRAGM ASSY	1	
20	3GM-1411E-00	..BLOCK, JET	1	
21	3FV-14933-00	..SPRING, DIAPHRAGM	1	
22	3GM-1490J-00	..NEEDLE SET	1	
23	3GM-1411A-00	..BLOCK JET ASSY	1	
24	3GM-14163-00	..WASHER, MAIN JET	1	
26	1HX-14566-00	..SCREW	1	
26	3LF-14147-00	..O-RING	1	
27	1AE-14147-00	..O-RING	1	
28	3GM-14997-00	..SEAL	1	

FIG. 11 CARBURETOR

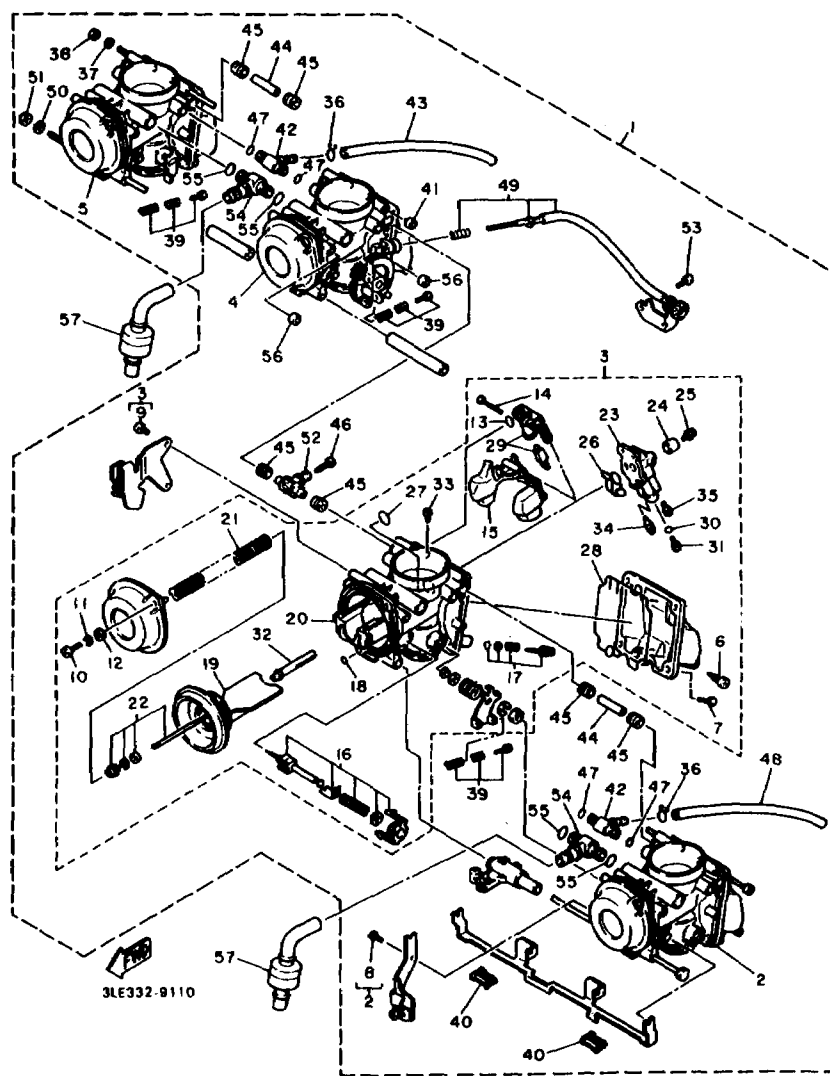

REF. NO.	PART NO.	DESCRIPTION	Q'TY	REMARKS
29	3GM-14107-17	..NEEDLE VALVE SET	1	
30	1AE-14227-00	..O-RING	1	
31	3G2-14231-25	..JET, MAIN (#125)	1	UR
	3G2-1423A-75-A1	..JET, MAIN (#122.5)	1	UR
32	3GM-14141-90	..NOZZLE, MAIN	1	
33	830-14231-23	..JET, MAIN (#115)	1	
34	4G0-14142-40	..JET, PILOT (# 40)	1	
35	3G2-14231-12	..JET, POWER (# 60)	1	
36	8U9-14139-00	.CLIP, PIPE	2	
37	92901-05600	.WASHER, PLATE	1	
38	95380-05600	.NUT	1	
39	3EN-1490K-00	.STOP SCREW SET	3	
40	3EN-14281-00	.HOLDER	2	
41	3GM-14918-00	.RING	1	
42	17A-14251-00	.NIPPLE	2	
43	2GH-14197-00	.PIPE	1	
44	3GM-14988-00	.PIPE, STARTER CONNECTING	2	
45	3EN-14997-00	.SEAL	6	
46	1KT-14994-00	.NET, FILTER	1	
47	822-14147-00	.O-RING	4	
48	3LF-14197-00	.PIPE	1	
49	3GM-14103-00	.THROTTLE SCREW SET	1	
50	92990-08600	.WASHER, PLATE	1	
51	95380-08600	.NUT	1	
52	3EN-14988-00	.PIPE, STARTER CONNECTING	1	
53	98501-05008	.SCREW, PAN HEAD	1	
54	3GM-14251-00	.NIPPLE	2	
55	3LK-14147-00	.O-RING	4	

FIG. 11 CARBURETOR

REF. NO.	PART NO.	DESCRIPTION	Q'TY	REMARKS
56	3GM-14992-00	.ROD	2	
57	3GM-14197-00	PIPE	2	

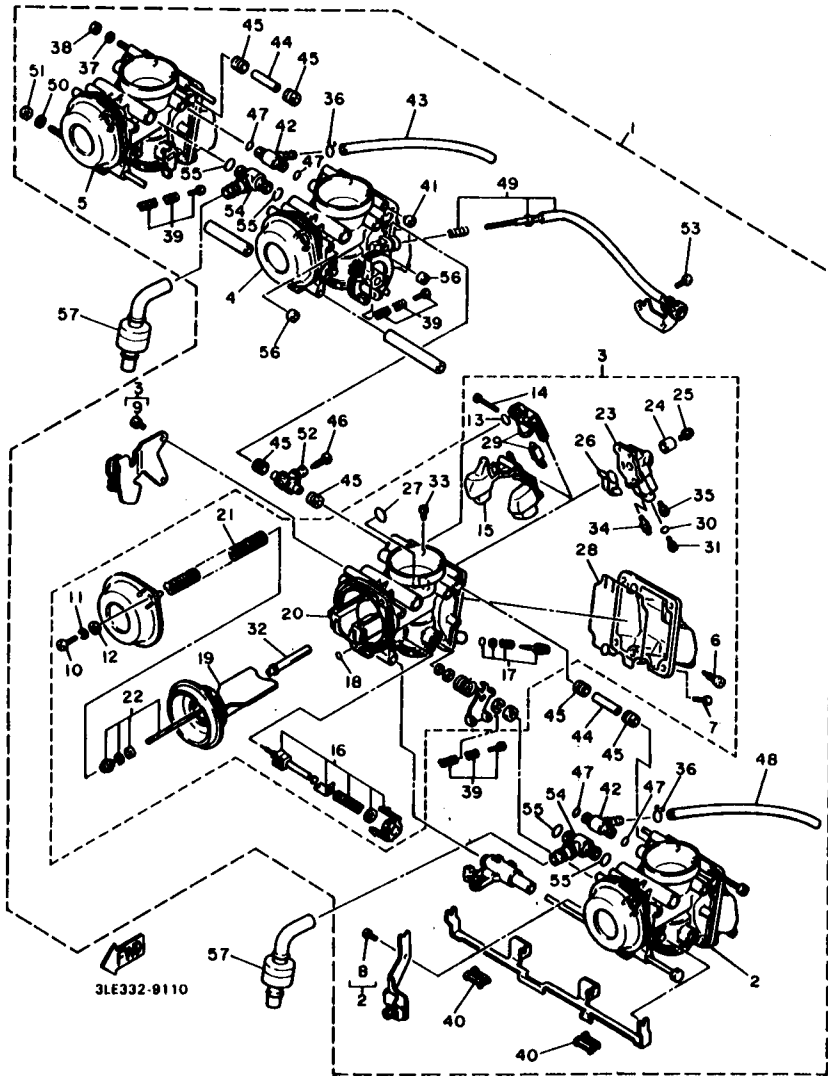
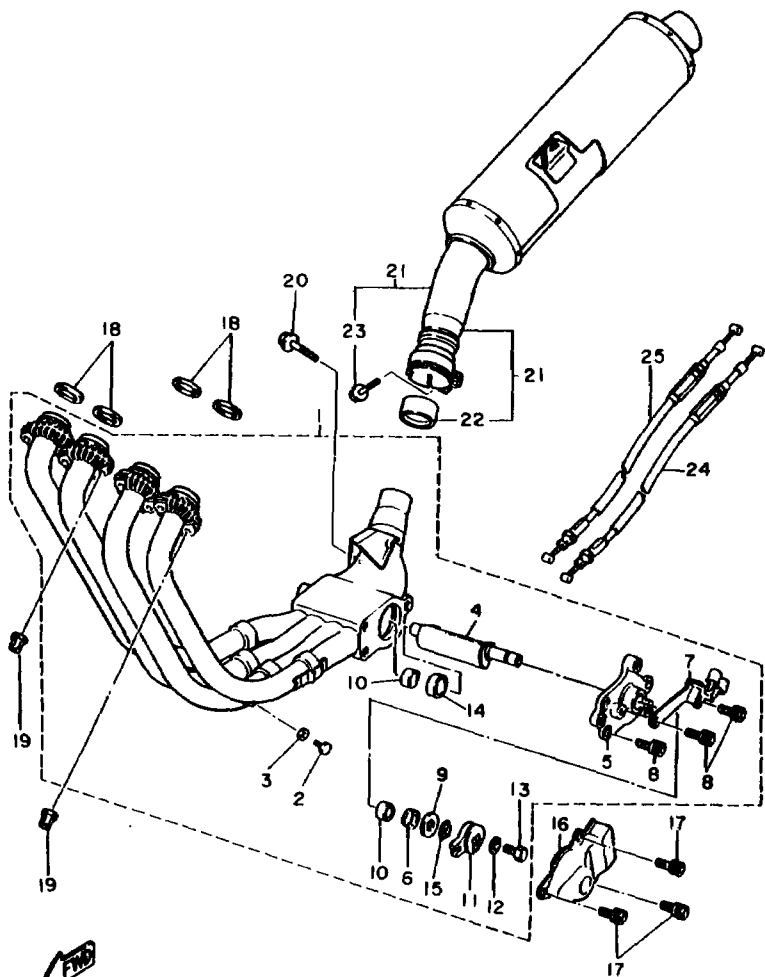

FIG. 12 EXHAUST



3LE332-1120

REF. NO.	PART NO.	DESCRIPTION	Q'TY	REMARKS
1	3GM-14610-00	EXHAUST PIPE ASSY 1	1	
2	90101-06576	.BOLT	4	
3	92906-08800	.WASHER, PLATE	4	
4	3GM-14821-00	.ARM, SHAFT (VALVE)	1	
5	3GM-14811-00	.HOUSING	1	
6	2TK-14845-00	.DUST SEAL ASSY	1	
7	2TK-14867-01	.BRACKET	1	
8	90119-06115	.BOLT, WITH WASHER	3	
9	90201-106M5	.WASHER, PLATE	1	
10	90380-10195	.BUSH, SOLID	2	
11	2TK-14865-01	.PULLEY	1	
12	92990-05200	.WASHER, PLAIN	1	
13	97395-05012	.BOLT	1	
14	90387-106U7	.COLLAR	1	
15	3GM-14683-00	.SPRING, HOOK	1	
16	4HD-14826-00	PROTECTOR, EXHAUST	1	
17	90119-06187	BOLT, WITH WASHER	3	
18	3YF-14813-01	GASKET, EXHAUST PIPE	4	
19	90179-08410	NUT	8	
20	95816-08035	BOLT, FLANGE	1	
21	3GM-14710-51	MUFFLER ASSY 1	1	
22	3HE-14755-00	.GASKET, SILENCER	1	
23	95816-08025	.BOLT, FLANGE	1	
24	3GM-1133E-51	CABLE, PULLEY 1	1	
25	3GM-1133F-51	CABLE, PULLEY 2	1	

FIG. 13 CRANKCASE

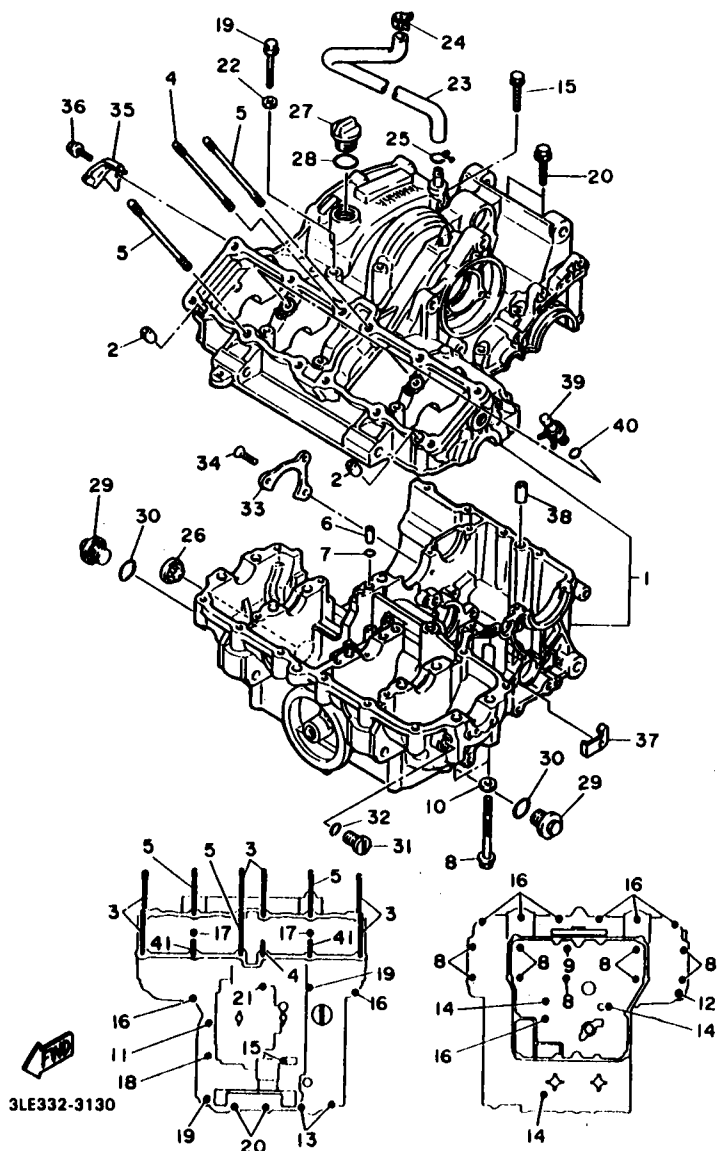

REF. NO.	PART NO.	DESCRIPTION	Q'TY	REMARKS
1	3GM-15100-52	CRANKCASE ASSY	1	
2	99530-10014	PIN, DOWEL	2	
3	90116-10532	BOLT, STUD	6	
4	90116-10531	BOLT, STUD	1	
5	90116-10576	BOLT, STUD	3	
6	90387-05383	COLLAR	1	
7	93210-07135	O-RING	1	
8	90105-09373	BOLT, WASHER BASED	9	
9	90105-09580	BOLT, WASHER BASED	1	
10	90201-096J9	WASHER, PLATE	4	
11	95811-08035	BOLT, FLANGE	1	
12	95811-08045	BOLT, FLANGE	1	
13	95811-08080	BOLT, FLANGE	2	
14	95811-08080	BOLT, FLANGE	3	
15	95811-08140	BOLT, FLANGE	1	
16	95811-08045	BOLT, FLANGE	9	
17	95811-08055	BOLT, FLANGE	2	
18	95811-08065	BOLT, FLANGE	1	
19	95811-08090	BOLT, FLANGE	2	
20	95811-08080	BOLT, FLANGE	2	
21	90105-09555	BOLT, WASHER BASED	1	
22	90201-08087	WASHER, PLATE	1	
23	1AE-11166-00	PIPE, BREATHER 1	1	
24	90467-15054	CLIP	1	
25	90467-14015	CLIP	1	
26	2H7-15381-00	GAUGE, LEVEL	1	
27	3FV-15383-00	PLUG, OIL	1	
28	93210-27778	O-RING	1	

FIG. 13 CRANKCASE

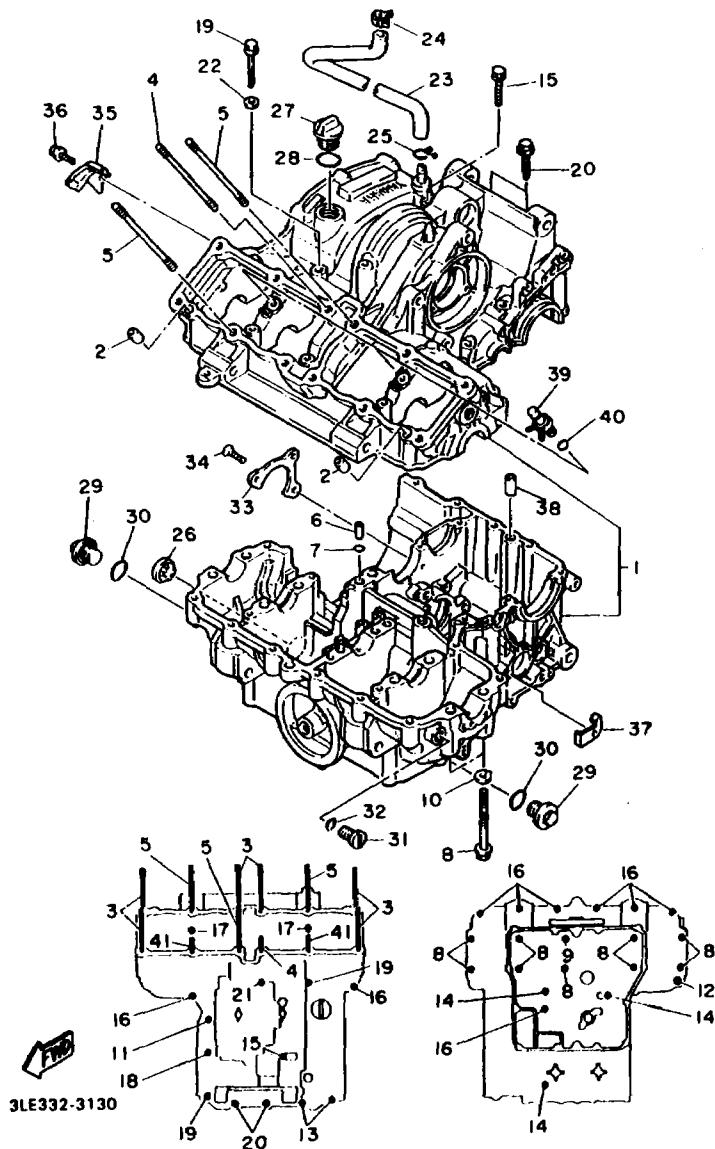

REF. NO.	PART NO.	DESCRIPTION	Q'TY	REMARKS
29	4H7-15189-00	PLUG	2	
30	93210-20573	O-RING	2	
31	90340-14068	PLUG, STRAIGHT SCREW	1	
32	93210-14369	O-RING	1	
33	1AE-15383-00	PLATE, BEARING COVER	1	
34	90151-06014	SCREW, COUNTERSUNK	3	
35	90462-08184	CLAMP	1	
36	95023-08012	BOLT	1	
37	90462-08158	CLAMP	1	
38	99510-12016	PIN, DOWEL	1	
39	2TK-15105-00	NOZZLE ASSY	2	
40	93210-08632	O-RING	2	
41	90116-10589	BOLT, STUD	2	

FIG. 14 CRANKCASE COVER 1

REF. NO.	PART NO.	DESCRIPTION	Q'TY	REMARKS
1	3GM-15416-00	COVER, OIL PUMP	2	
2	1AE-15456-00	GASKET, OIL PUMP COVER 1	2	
3	90152-08014	SCREW, COUNTERSUNK	6	
4	3GM-15410-00	CRANKCASE COVER ASSY 1	1	
5	2GH-15435-00	EMBLEM	1	
6	3GM-15427-00	COVER, CAP 2	1	
7	1AE-15316-00	DAMPER, ENGINE MOUNT 1	1	
8	92011-08010	BOLT, BUTTON HEAD	1	
9	4BH-15461-00	GASKET, CRANKCASE COVER 1	1	
10	4CR-15467-00	GASKET	1	
11	99510-08012	PIN, DOWEL	2	
12	96023-08040	BOLT	3	
13	95021-08050	BOLT, FLANGE	2	
14	3GM-15421-00	COVER, CRANKCASE 2	1	
15	3GM-15362-00	PLUG, OIL LEVEL	1	
16	93210-27778	O-RING	1	
17	3GM-15417-00	COVER, CAP	1	
18	3GM-15449-00	RING, RUBBER	1	
19	4H7-15486-00	GROMMET	3	
20	90209-06096	WASHER	3	
21	98580-08010	SCREW, PAN HEAD	3	
22	3GM-15346-00	BREATHER 1	1	
23	4BH-15463-00	GASKET, CARBURETOR COVER 2	1	
24	98580-08020	SCREW, PAN HEAD	4	
25	90157-08104	SCREW, PAN HEAD	1	
26	90152-08024	SCREW, COUNTERSUNK	1	
27	4BH-15461-00	GASKET, CRANKCASE COVER 2	1	
28	99510-08012	PIN, DOWEL	2	

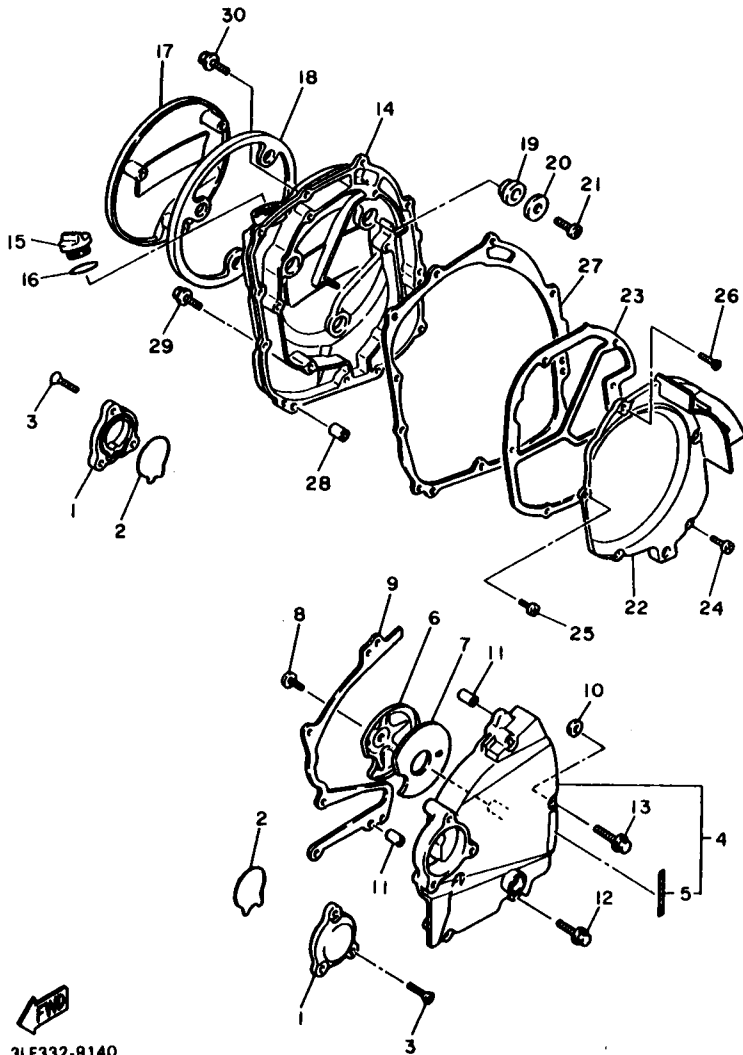
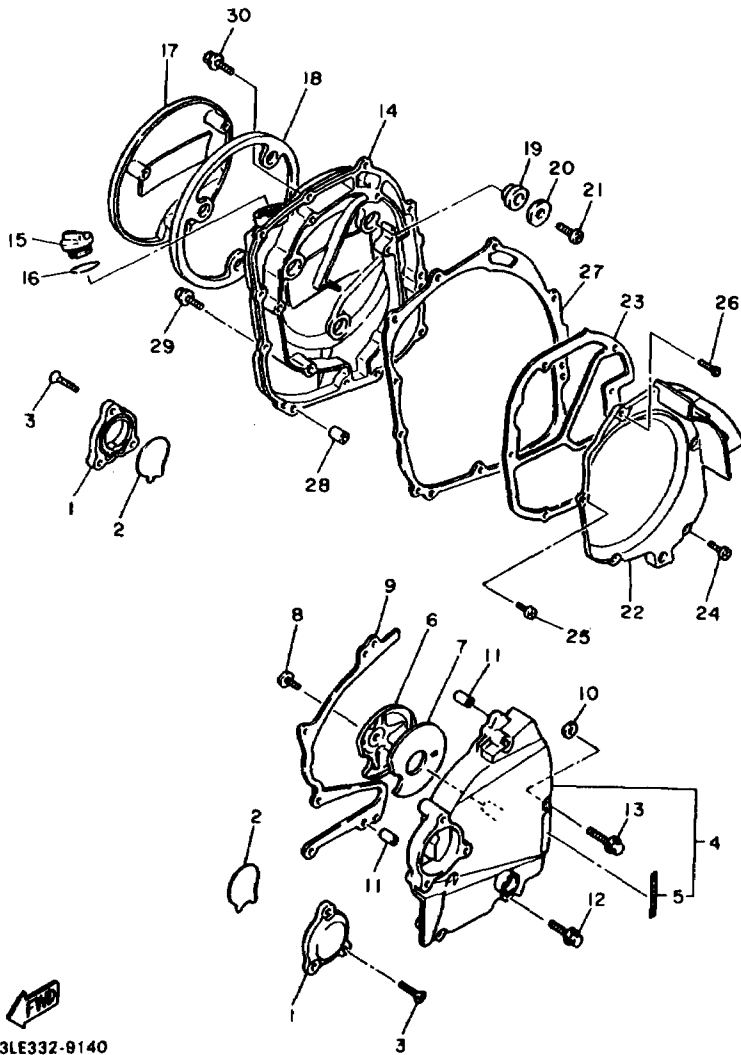

FIG. 14 CRANKCASE COVER 1

REF. NO.	PART NO.	DESCRIPTION	Q'TY	REMARKS
29	95023-08030	BOLT	2	
30	95023-08020	BOLT	9	



3LE332-9140

FIG. 15 STARTER

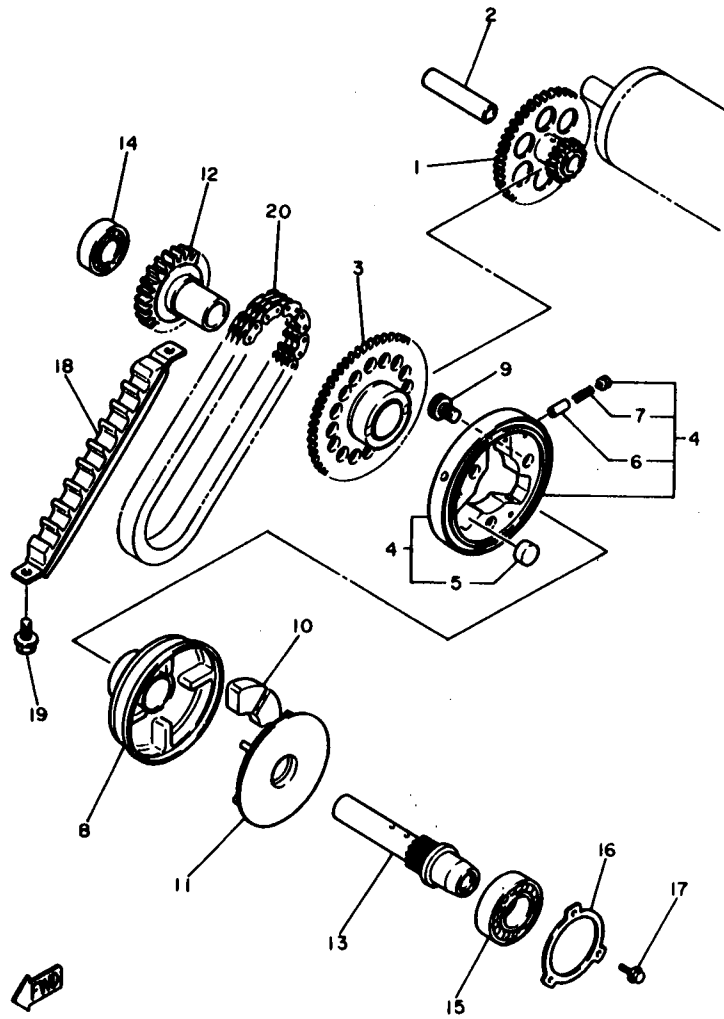

REF. NO.	PART NO.	DESCRIPTION	Q'TY	REMARKS
1	3GM-15512-00	GEAR, IDLER 1	1	
2	51Y-15521-00	SHAFT 1	1	
3	4BH-15517-00	GEAR, IDLER 2	1	
4	3GM-15580-00	STARTER CLUTCH OUTER ASSY	1	
5	93815-12088	.PIN, DOWEL	3	
6	1J7-15583-01	.CAP, STARTER CLUTCH SPRING	3	
7	90501-04823	.SPRING, COMPRESSION	3	
8	3GM-15524-00	WHEEL, STARTER	1	
9	90110-08177	BOLT, HEXAGON SOCKET HEAD	3	
10	4H7-18155-01	ABSORBER 1	4	
11	3GM-15689-00	RETAINER	1	
12	3GM-15519-00	SPROCKET, STARTER 2	1	
13	3GM-15522-00	SHAFT 2	1	
14	93306-20335	BEARING	1	
15	93306-20541	BEARING (B6205)	1	
16	1AE-15381-00	PLATE, BEARING COVER	1	
17	95026-06016	BOLT, FLANGE	3	
18	3GM-11474-00	GUIDE, UPPER	1	
19	95816-06014	BOLT, FLANGE	2	
20	4FM-11456-00	CHAIN, PRIMARY	1	

3KS351-9150

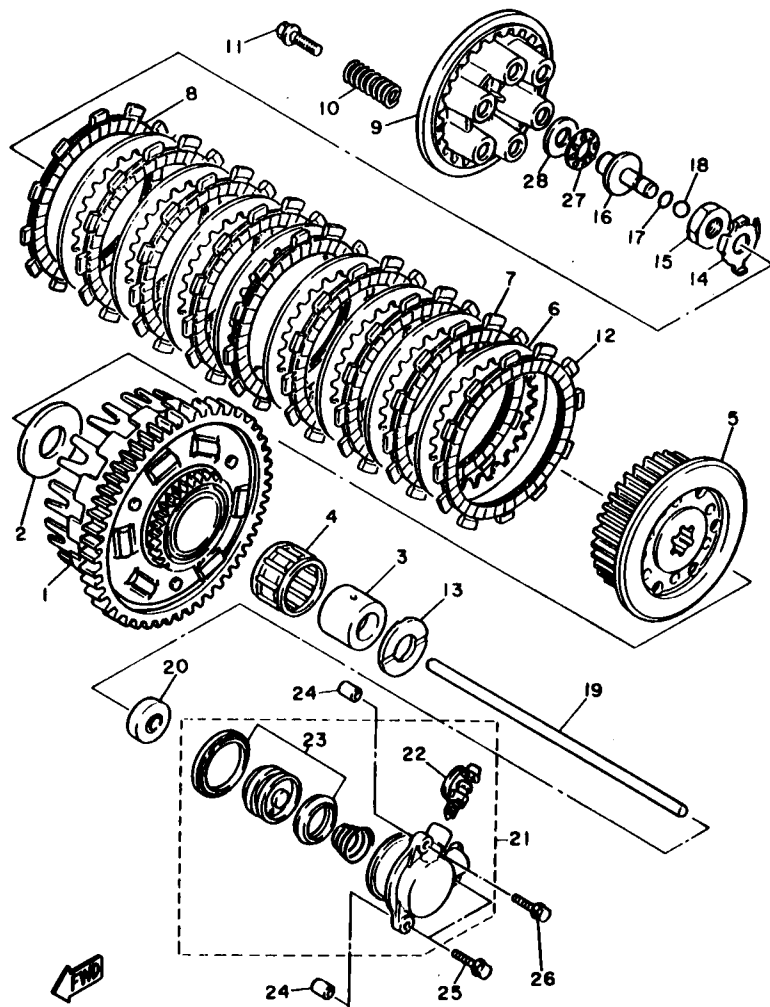

3LE332-3160

FIG. 16 CLUTCH

REF. NO.	PART NO.	DESCRIPTION	Q'TY	REMARKS
1	3GM-16150-01	PRIMARY DRIVEN GEAR COMP.	1	
2	1AE-16154-00	PLATE, THRUST 1	1	
3	90560-25270	SPACER	1	
4	93310-340N8	BEARING, CYLINDRICAL	1	
5	4BH-16371-01	BOSS, CLUTCH	1	
6	31A-16325-00	PLATE, CLUTCH 2	8	
7	4H7-16321-01	PLATE, FRICTION	7	
8	31A-16321-00	PLATE, FRICTION	1	
9	3GM-16351-00	PLATE, PRESSURE 1	1	
10	90501-230E4	SPRING, COMPRESSION	6	
11	90159-06123	SCREW, WITH WASHER	6	
12	3GM-16321-00	PLATE, FRICTION	1	
13	1AE-16164-00	PLATE, THRUST 2	1	
14	90215-20231	WASHER, LOCK	1	
15	90170-20327	NUT	1	
16	3GM-16358-00	ROD, PUSH 1	1	
17	93210-06632	O-RING	1	
18	93511-32027	BALL	1	
19	1AE-16357-00	ROD, PUSH 2	1	
20	93109-08061	OIL SEAL	1	
21	1TV-16381-10	PUSH LEVER COMP.	1	
22	36Y-W0048-00	.BRED SCREW KIT	1	
23	26H-W0098-00	.PUSH LEVER SEAL KIT	1	
24	99510-08012	PIN, DOWEL	2	
25	95026-06030	BOLT, FLANGE	2	
26	95026-06090	BOLT, FLANGE	1	
27	93340-21505	BEARING, THRUST	1	
28	90201-150H2	WASHER, PLATE	1	

FIG. 17 TRANSMISSION

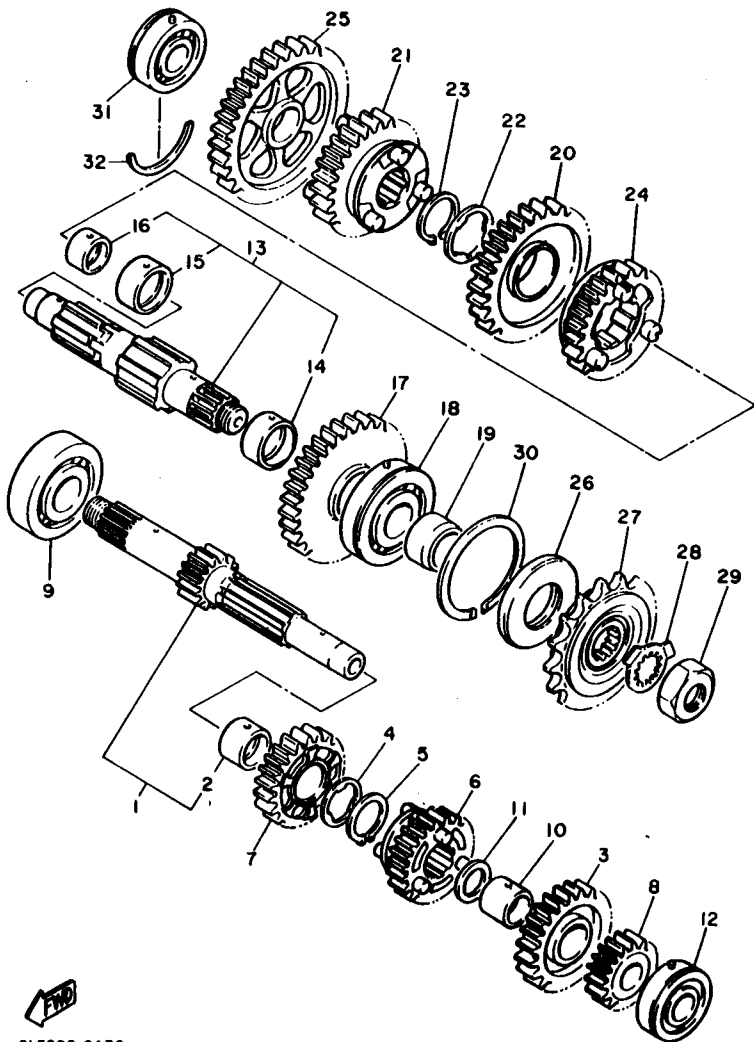

3LE332-9170

REF. NO.	PART NO.	DESCRIPTION	Q'TY	REMARKS
1	3LE-W1741-00	MAIN AXLE ASSY	1	
2	90387-253M6	.COLLAR	1	
3	2GH-17151-00	GEAR, 5TH PINION (27T)	1	
4	90209-22191	WASHER	1	
5	93440-25084	CIRCLIP	1	
6	2GH-17131-00	GEAR, 3RD PINION (21T)	1	
7	2GH-17141-00	GEAR, 4TH PINION (23T)	1	
8	2GH-17121-00	GEAR, 2ND PINION (18T)	1	
9	93306-30525	BEARING (B6305)	1	
10	90387-203M7	COLLAR	1	
11	90201-200K3	WASHER, PLATE	1	
12	93306-20455	BEARING	1	
13	3GM-W1742-00	DRIVE AXLE ASSY	1	
14	90387-271T7	.COLLAR	1	
15	90387-281T8	.COLLAR	1	
16	90387-211T9	.COLLAR	1	
17	3GM-17221-00	GEAR, 2ND WHEEL (32T)	1	
18	93305-30501	BEARING	1	
19	90387-255V9	COLLAR	1	
20	3GM-17231-00	GEAR, 3RD WHEEL (29T)	1	
21	3GM-17241-00	GEAR, 4TH WHEEL (27T)	1	
22	90209-25196	WASHER	1	
23	93440-28062	CIRCLIP	1	
24	3GM-17251-00	GEAR, 5TH WHEEL (28T)	1	
26	2GH-17211-01	GEAR, 1ST WHEEL	1	
28	93102-36423	OIL SEAL	1	
27	2GH-17460-11	SPROCKET,DRIVE 17T(2GH1746170)	1	
28	90215-21022	WASHER, LOCK	1	

FIG. 17 TRANSMISSION

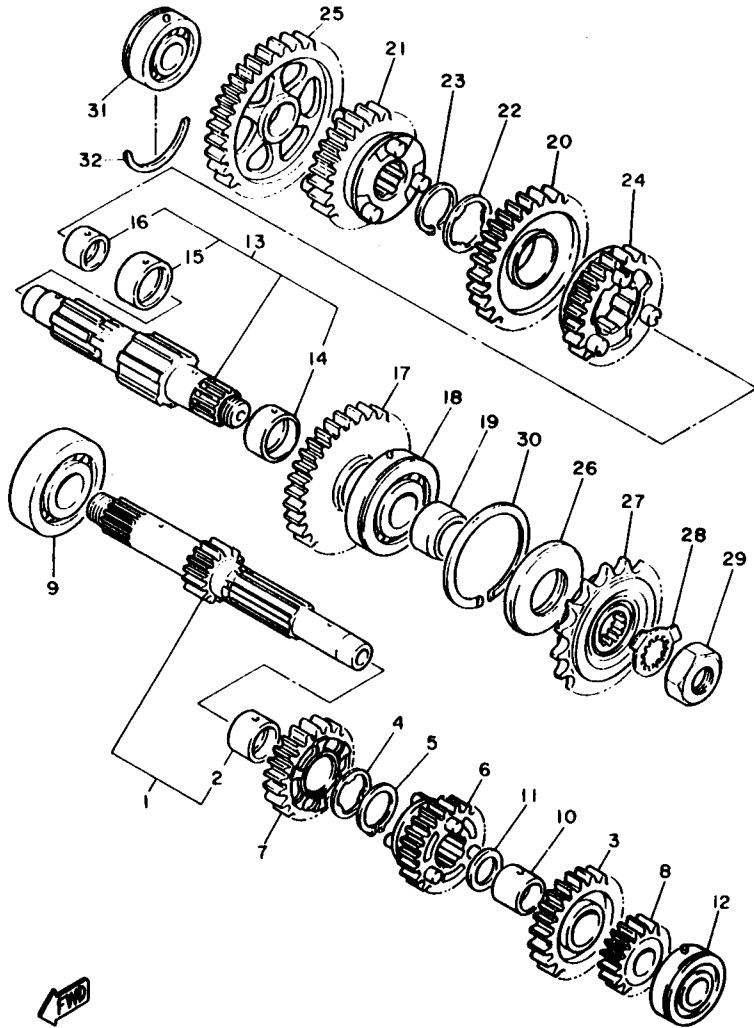

3LE332-9170

REF. NO.	PART NO.	DESCRIPTION	Q'TY	REMARKS
29	90179-18020	NUT	1	
30	278-17424-01	CIRCLIP 1	1	
31	93306-20465	BEARING	1	
32	93440-45144	CIRCLIP	1	

FIG. 18 SHIFT CAM . FORK

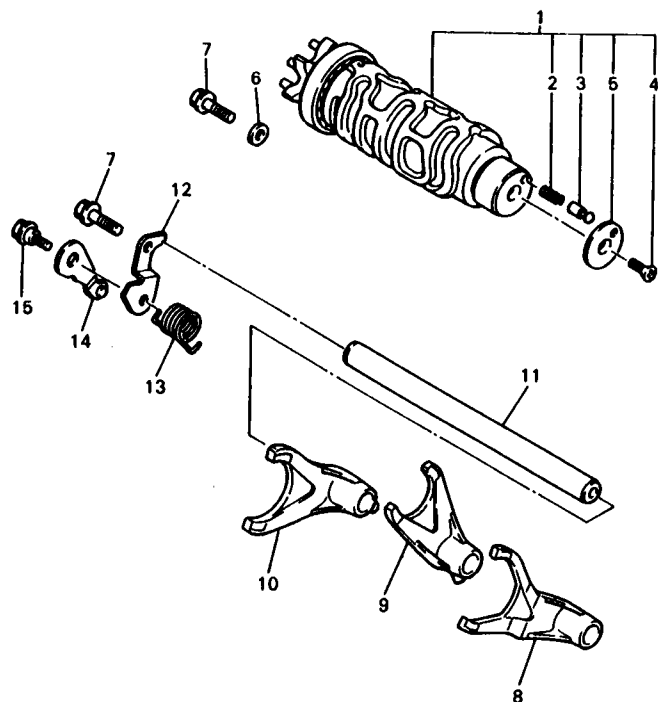

REF. NO.	PART NO.	DESCRIPTION	Q'TY	REMARKS
1	4BH-18540-00	SHIFT CAM ASSY	1	
2	90501-06022	.SPRING, COMPRESSION	1	
3	278-18542-00	.POINT, NEUTRAL	1	
4	98701-05012	.SCREW, FLAT HEAD	1	
5	278-18566-00	.PLATE, SIDE 2	1	
6	90201-06643	WASHER, PLATE	1	
7	95811-06016	BOLT, FLANGE	2	
8	3LE-18511-00	FORK, SHIFT 1	1	
9	3LE-18512-00	FORK, SHIFT 2	1	
10	3LE-18513-00	FORK, SHIFT 3	1	
11	4BH-18531-00	BAR, SHIFT FORK GUIDE 1	1	
12	1AE-18536-00	STOPPER, SHIFT BAR	1	
13	90508-26681	SPRING, TORSION	1	
14	36Y-18140-00	STOPPER LEVER ASSY	1	
15	90109-063F8	BOLT	1	



3LE332-4180

FIG. 19 SHIFT SHAFT

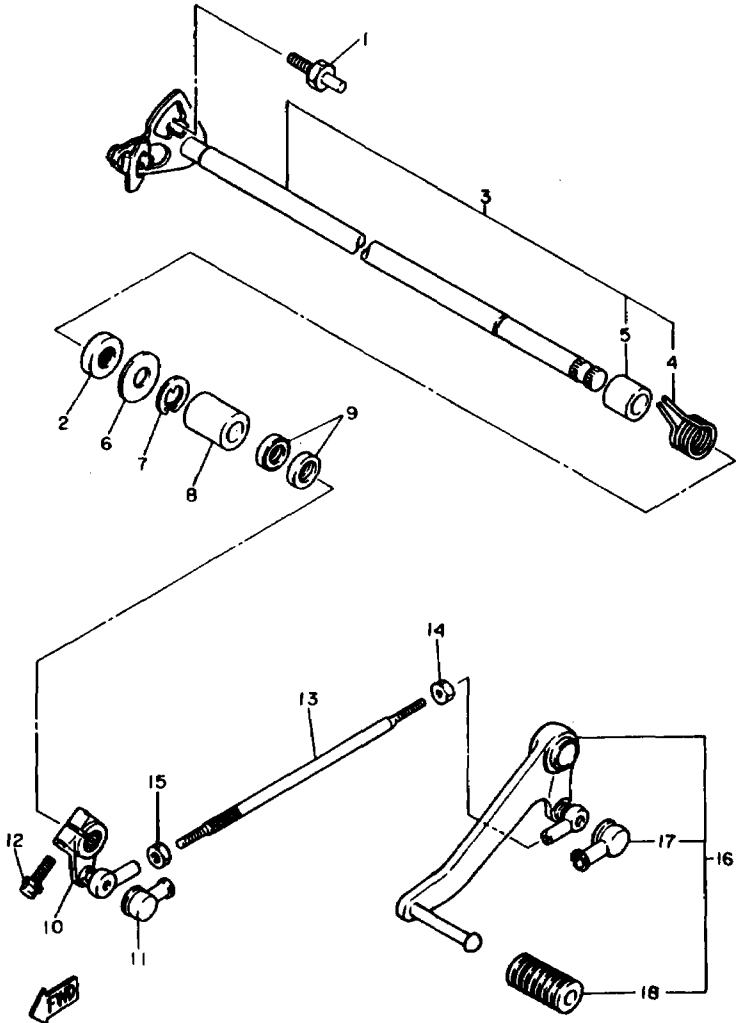

3LF361-0190

REF. NO.	PART NO.	DESCRIPTION	Q'TY	REMARKS
1	4G0-18127-00	STOPPER, SCREW	1	
2	93102-12321	OIL SEAL	1	
3	1AE-18101-01	SHIFT SHAFT ASSY	1	
4	90508-32682	.SPRING, TORSION	1	
5	90387-114K8	.COLLAR	1	
6	90201-12575	WASHER, PLATE	1	
7	99006-10600	CIRCLIP	1	
8	90560-12191	SPACER	1	
9	93109-12053	OIL SEAL (SDO 12/18/4-1)	2	
10	2GH-18112-01	ARM, SHIFT	1	
11	2H9-18154-00	COVER, DUST	1	
12	95826-06020	BOLT, FLANGE	1	
13	48X-18115-00	ROD, SHIFT	1	
14	90170-08228	NUT(COUNTER CLOCKWISE)	1	
15	95380-06700	NUT	1	
16	2GH-18110-00	SHIFT PEDAL ASSY	1	
17	2H9-18154-00	.COVER, DUST	1	
18	132-18113-01	.COVER, SHIFT PEDAL	1	

FIG. 20 FRAME

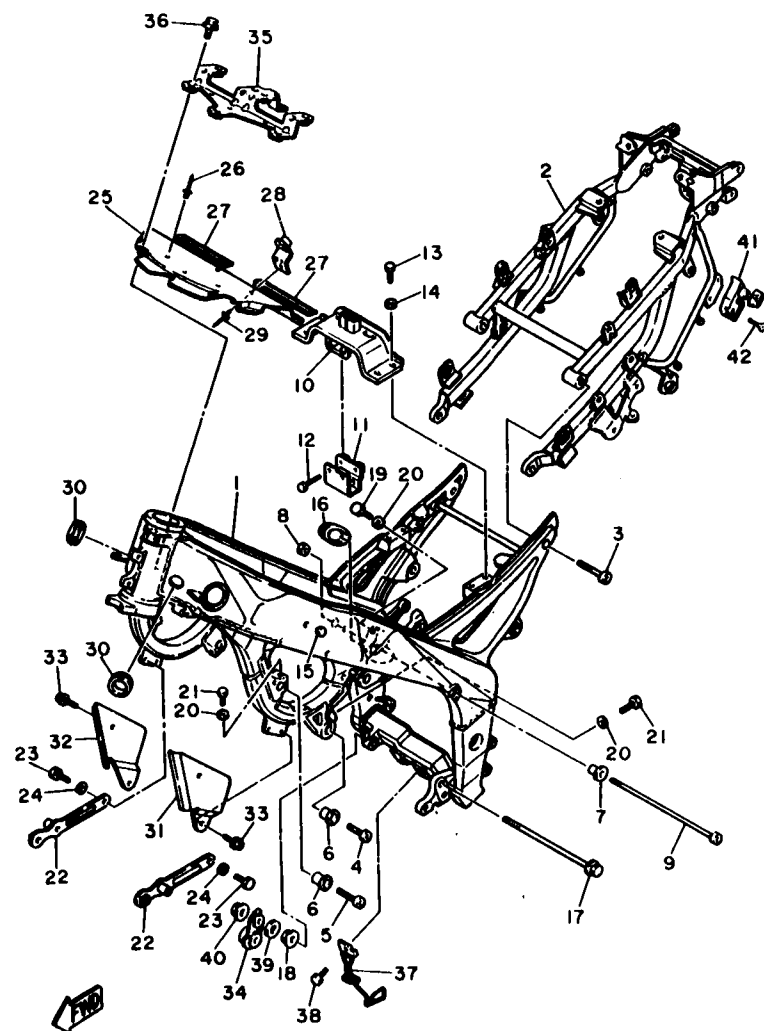

3LE332-2200

REF. NO.	PART NO.	DESCRIPTION	Q'TY	REMARKS
1	3GM-21110-60	FRAME COMP.	1	
2	3GM-21190-50-33	REAR FRAME COMP.	1	YAMAHA BLACK
3	90110-10191	BOLT, HEXAGON SOCKET HEAD	4	
4	91316-10045	BOLT	2	
5	90110-10168	BOLT, HEXAGON SOCKET HEAD	2	
6	90387-115V8	COLLAR	4	
7	90387-105V7	COLLAR	1	
8	90179-10590	NUT	1	
9	90110-10169	BOLT, HEXAGON SOCKET HEAD	1	
10	3GM-21348-51	BRACKT, TANK FITTING	1	
11	3GM-21347-00	BRACKET, TANK FITTING	1	
12	97013-06035	BOLT	2	
13	97013-06012	BOLT	4	
14	92990-06600	WASHER, PLATE	4	
15	90338-15202	PLUG	3	
16	2GH-2117T-00	COVER 5	1	
17	90105-10716	BOLT, WASHER BASED	1	
18	90179-10247	NUT	1	
19	97026-08035	BOLT	2	
20	92890-08200	WASHER, PLAIN	6	
21	97021-08035	BOLT	4	
22	3GM-2142K-50	BRACKET, RADIATOR	2	
23	97013-06012	BOLT	2	
24	92990-06600	WASHER, PLATE	2	
25	3GM-2117M-00	COVER 2	1	
26	90267-40076	RIVET, BLIND	4	
27	2GH-15365-00	GROMMET	2	
28	3GM-2117A-00	STAY	2	

FIG. 20 FRAME

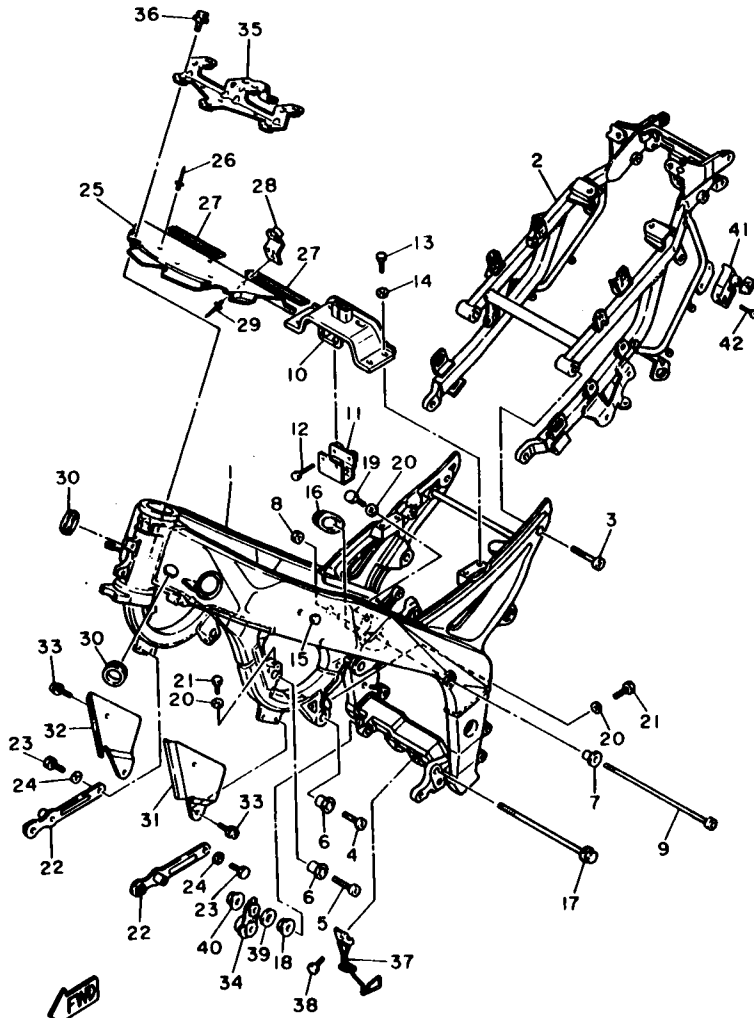

3LE332-2200

REF. NO.	PART NO.	DESCRIPTION	Q'TY	REMARKS
29	90287-40054	RIVET, BLIND	2	
30	90480-36626	GROMMET	2	
31	3GM-2117N-00	COVER 3	1	
32	3GM-2117R-00	COVER 4	1	
33	90159-08058	SCREW, WITH WASHER	4	
34	3GM-21446-03	STAY, MUFFLER 2	1	
35	3GM-21359-00	BRACKET, COIL	1	
36	90119-08114	BOLT, WITH WASHER	3	
37	3GM-21149-00	BRACKET, BATTERY BOX	1	
38	91028-08010	BOLT	1	
39	90201-101J1	WASHER, PLATE	1	
40	95706-10500	NUT, FLANGE	1	
41	26H-21308-00	HELMET HANGER ASSY	1	
42	90149-08150	SCREW	1	

FIG. 21 FENDER

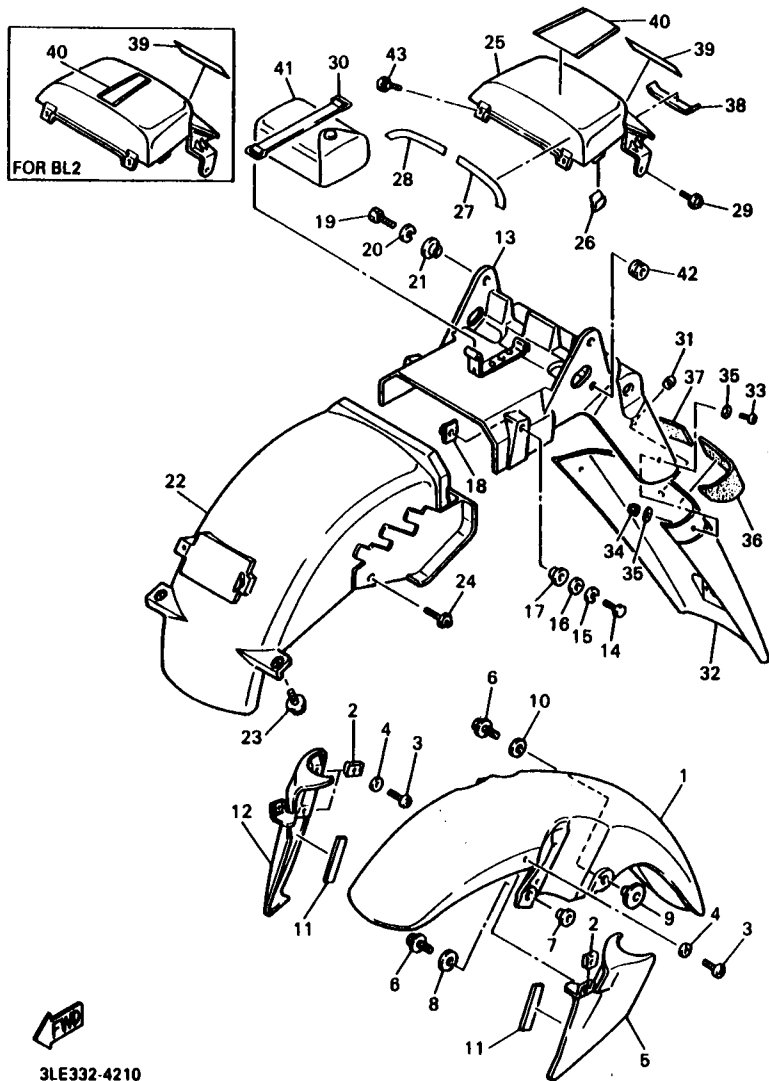

REF. NO.	PART NO.	DESCRIPTION	Q'TY	REMARKS
1	3GM-21511-51-P0	FENDER, FRONT	1	UR BLUISH WHITE COCKTAIL 1 UR BLACK 2
	3GM-21511-51-4B	FENDER, FRONT	1	
2	90183-05061	NUT, SPRING	6	
3	90154-05060	SCREW, BINDING	6	
4	90202-05088	WASHER, PLATE	6	
5	3GM-21551-A0-P0	FENDER, OVER	1	UR BLUISH WHITE COCKTAIL 1 UR BLACK 2
	3GM-21551-A0-4B	FENDER, OVER	1	
6	90119-08063	BOLT, WITH WASHER	4	
7	90387-06648	COLLAR	2	
8	90202-11221	WASHER, PLATE	2	
9	90387-0604T	COLLAR	2	
10	4FM-28372-00	DAMPER	2	
11	1FK-21746-00	DAMPER	2	
12	3GM-21555-A0-P0	FENDER, OVER 2	1	UR BLUISH WHITE COCKTAIL 1 UR BLACK 2
	3GM-21555-A0-4B	FENDER, OVER 2	1	
13	3GM-W2161-01	REAR FENDER COMP.	1	
14	97011-08020	BOLT	2	
15	92995-08100	WASHER, SPRING	2	
16	92901-08600	WASHER, PLATE	2	
17	90387-081M0	COLLAR	2	
18	31A-14477-00	PLATE	2	
19	97095-08016	BOLT	2	
20	92995-08100	WASHER, SPRING	2	
21	90387-06648	COLLAR	2	
22	3GM-21829-50	GUARD, MUD	1	
23	90119-08108	BOLT, WITH WASHER	2	
24	90159-08058	SCREW, WITH WASHER	1	
25	3GM-21851-50-P0	COVER, REAR FENDER	1	UR BLUISH WHITE COCKTAIL 1

3LE332-4210

FIG. 21 FENDER

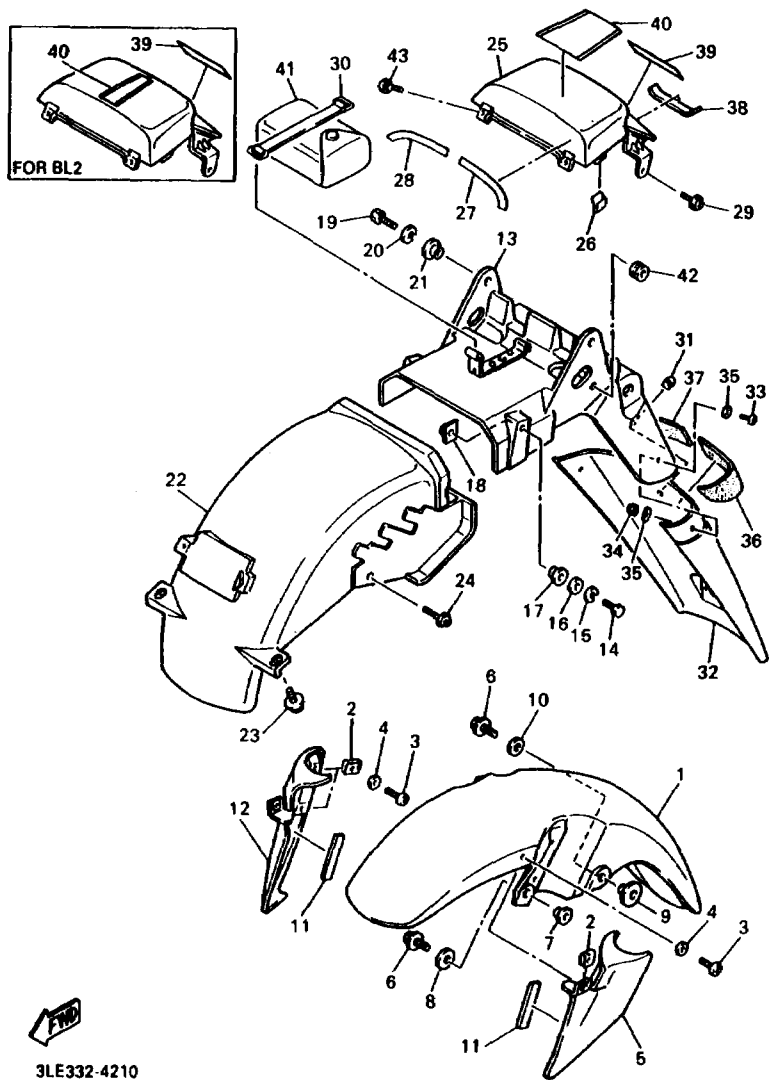

REF. NO.	PART NO.	DESCRIPTION	Q'TY	REMARKS
25	3GM-21861-50-4B	COVER, REAR FENDER	1	UR BLACK 2
26	2GH-21732-00	SEAL 1	2	
27	3GM-21575-00	SEAL 1	1	FOR EUROPE
28	3GM-21576-00	SEAL 2	1	FOR EUROPE
29	90159-06042	SCREW, WITH WASHER	2	
30	26L-82131-00	BAND, BATTERY	1	
31	90338-07043	PLUG	1	
32	3GM-21621-00	FLAP	1	
33	90149-04278	SCREW	4	
34	95606-04100	NUT, U	4	
35	90201-044A2	WASHER, PLATE	8	
36	3GM-21649-00	DAMPER	1	
37	3GM-21649-10	DAMPER	1	
38	1FK-22483-00	DAMPER 1	1	
39	99237-00080	EMBLEM, YAMAHA	1	
40	3LE-21683-00	GRAPHIC, TAILCOVER	1	UR FOR BWC1
	3LE-21683-10	GRAPHIC, TAILCOVER	1	UR FOR BL2
41	3LE-28100-00	TOOL KIT	1	
42	90480-10268	GROMMET	2	
43	90159-06033	SCREW, WITH WASHER	2	

3LE332-4210

FIG. 22 SIDE COVER

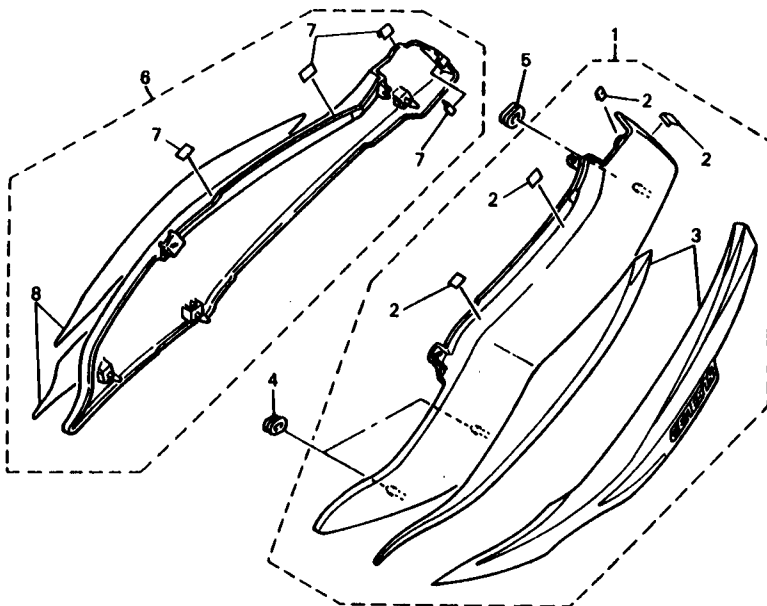
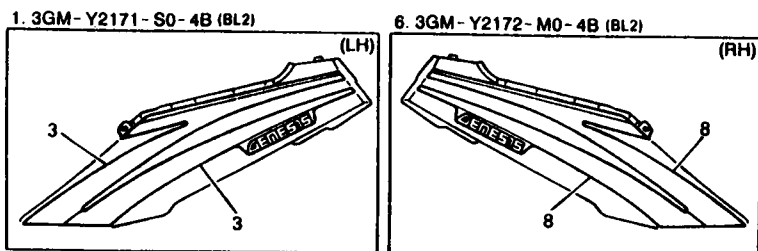

REF. NO.	PART NO.	DESCRIPTION	Q'TY	REMARKS
1	3GM-Y2171-R0-P1	COVER, SIDE 1	1	UR BLUISH WHITE
	3GM-Y2171-S0-4B	COVER, SIDE 1	1	COCKTAIL 1
				UR BLACK 2
2	2GH-21732-00	.SEAL 1	4	
3	3LE-2173L-01	.GRAPHIC SET 1	1	UR FOR BWC1
	3LE-2173L-10	.GRAPHIC SET 1	1	UR FOR BL2
4	90480-01401	GROMMET	2	
5	90480-22084	GROMMET	1	
6	3GM-Y2172-L0-P1	COVER, SIDE 2	1	UR BLUISH WHITE
	3GM-Y2172-M0-4B	COVER, SIDE 2	1	COCKTAIL 1
				UR BLACK 2
7	2GH-21732-00	.SEAL 1	4	
8	3LE-2174L-01	.GRAPHIC SET 2	1	UR FOR BWC1
	3LE-2174L-10	.GRAPHIC SET 2	1	UR FOR BL2



3GME300-4220

FIG. 23 SIDE COVER 2

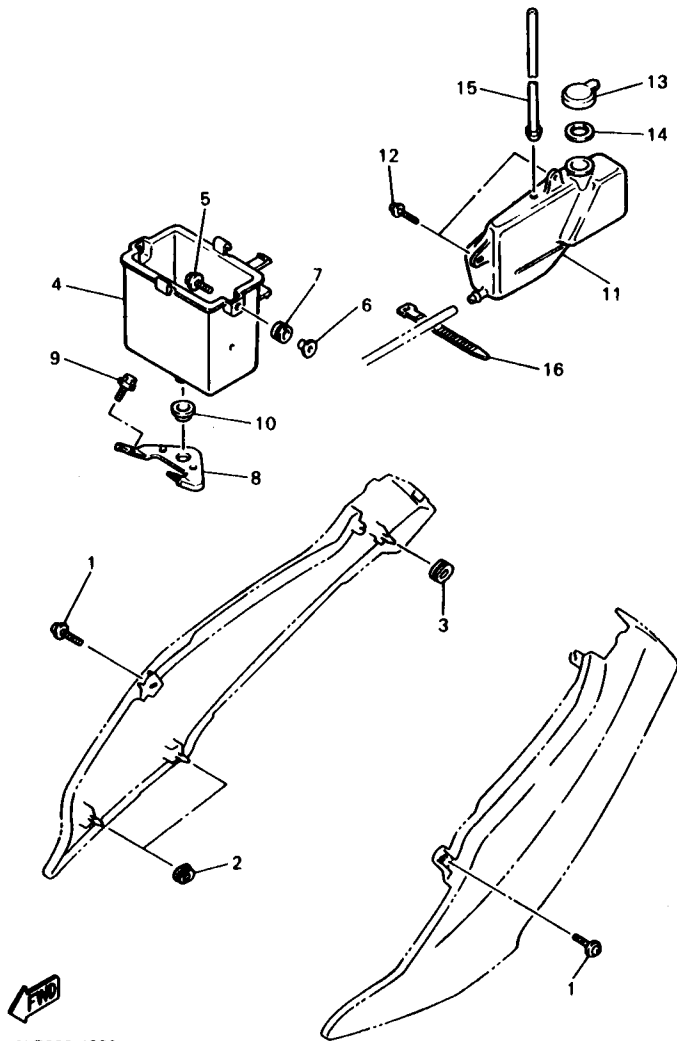

3LE332-4230

REF. NO.	PART NO.	DESCRIPTION	Q'TY	REMARKS
1	90159-06033	SCREW, WITH WASHER	2	
2	90480-01401	GROMMET	2	
3	90480-22084	GROMMET	1	
4	3GM-2177G-50	BOX, BATTERY	1	
5	90119-06063	BOLT, WITH WASHER	2	
6	90387-06024	COLLAR	2	
7	90480-15058	GROMMET	2	
8	3GM-21249-50	BRACKET	1	
9	95811-06012	BOLT, FLANGE	2	
10	90480-22362	GROMMET	1	
11	3GM-21871-50	TANK, RECOVERY	1	
12	90159-06033	SCREW, WITH WASHER	2	
13	4L0-21875-00	CAP	1	
14	1AA-21874-00	GASKET	1	
15	3GM-21816-00	PIPE 1	1	
18	437-83936-11	BAND, SWITCH CORD	1	

D6

FIG. 24 REAR ARM

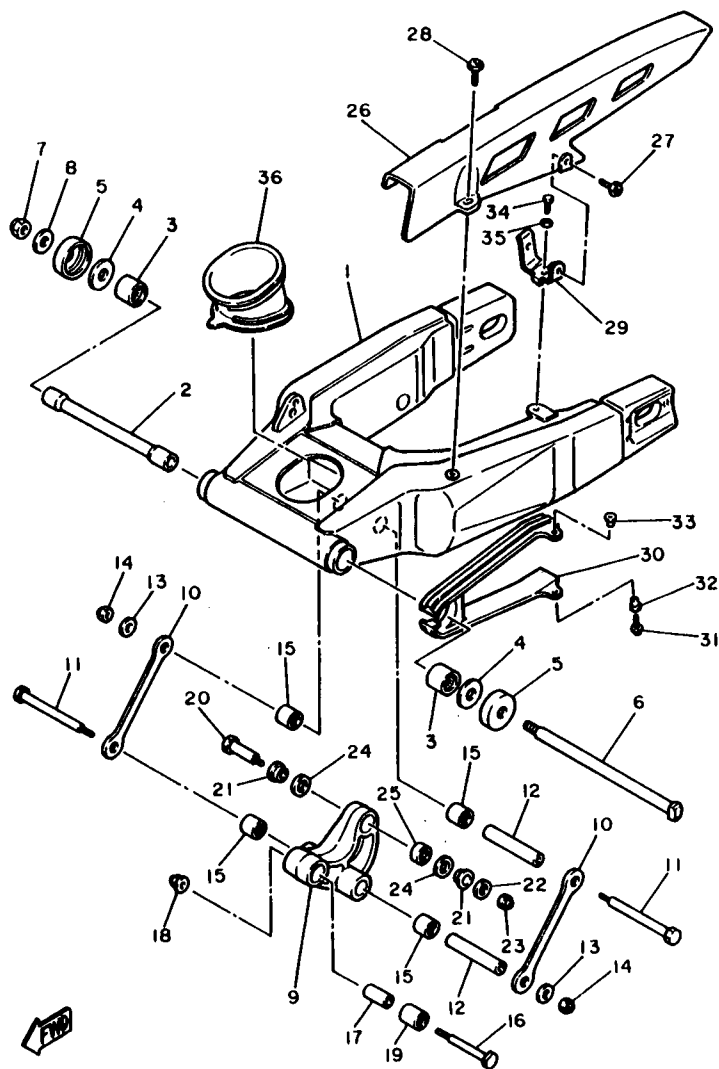

3LE332-2240

REF. NO.	PART NO.	DESCRIPTION	Q'TY	REMARKS
1	3GM-22110-00	REAR ARM COMP.	1	
2	3GM-22184-00	BUSH	1	
3	93317-62866	BEARING, CYLINDRICAL	2	
4	3GM-22127-00	SHIM	2	
5	3GM-22128-00	COVER, THRUST 1	2	
6	3GM-22141-00	SHAFT, PIVOT	1	
7	90186-18104	NUT, SELF-LOCKING	1	
8	90201-18264	WASHER, PLATE	1	
9	3GM-2217A-00	ARM, RELAY	1	
10	3GM-2217M-00	ARM 1	2	
11	90101-12673	BOLT	2	
12	90387-128T1	COLLAR	2	
13	90201-126A7	WASHER, PLATE	2	
14	95611-12100	NUT, U	2	
15	93317-41761	BEARING, CYLINDRICAL	4	
16	90109-101F1	BOLT	1	
17	90387-100T8	COLLAR	1	
18	95601-10200	NUT, SELF-LOCKING	1	
19	93317-42060	BEARING, CYLINDRICAL	1	
20	90101-10669	BOLT	1	
21	90387-124W2	COLLAR	2	
22	90201-10437	WASHER, PLATE	1	
23	95611-10100	NUT, U	1	
24	93101-16131	OIL SEAL	2	
25	93399-99919	BEARING	1	
26	3GM-22311-10	CASE, CHAIN	1	
27	90159-08084	SCREW, WITH WASHER	1	
28	90159-08108	SCREW, WITH WASHER	1	

FIG. 24 REAR ARM

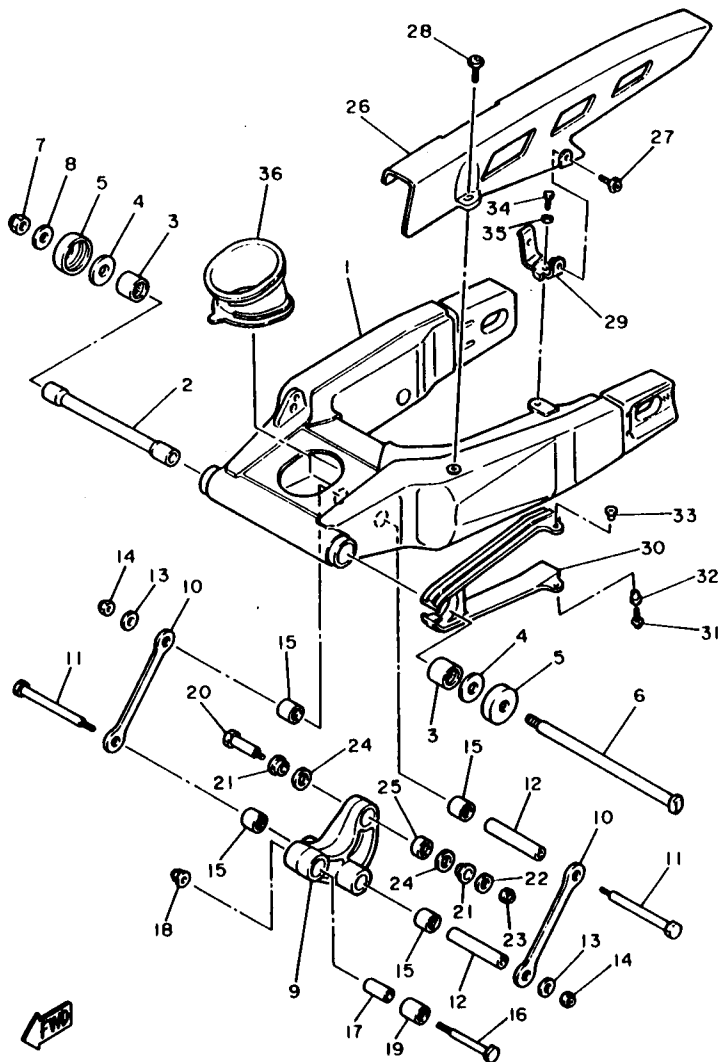

3LE332-2240

REF. NO.	PART NO.	DESCRIPTION	Q'TY	REMARKS
29	3GM-22321-00	STAY, CHAIN CASE 1	1	
30	3GM-22151-00	SEAL, GUARD	1	
31	90159-08108	SCREW, WITH WASHER	1	
32	90387-08704	COLLAR	1	
33	90387-08216	COLLAR	1	
34	97013-08012	BOLT	1	
35	92995-08100	WASHER, SPRING	1	
36	3GM-22129-00	COVER, THRUST 2	1	

FIG. 25 REAR SUSPENSION

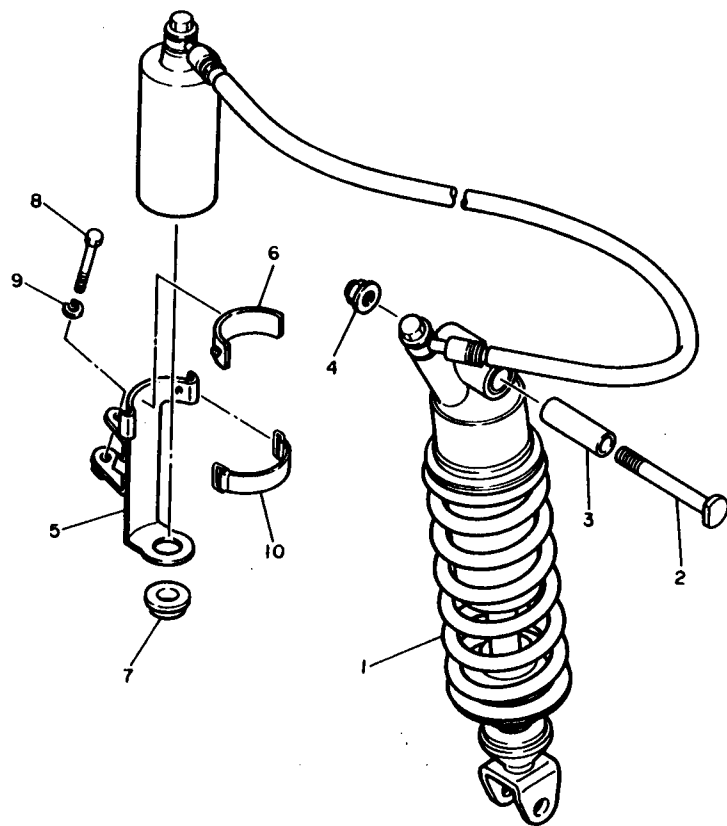

REF. NO.	PART NO.	DESCRIPTION	Q'TY	REMARKS
1	3GM-22210-10	SHOCK ABSORBER ASSY, REAR	1	
2	90109-101F1	BOLT	1	
3	90387-102T0	COLLAR	1	
4	95601-10200	NUT, SELF-LOCKING	1	
5	3GM-22262-00	HOLDER, SUB TANK	1	
6	24X-22261-00	DAMPER, SUB TANK	1	
7	90480-17359	GROMMET	1	
8	97001-08040	BOLT	1	
9	92995-06100	WASHER, SPRING	1	
10	24X-22262-00	HOLDER, SUB TANK	1	



3LE332-9240

D9

FIG. 26 STEERING

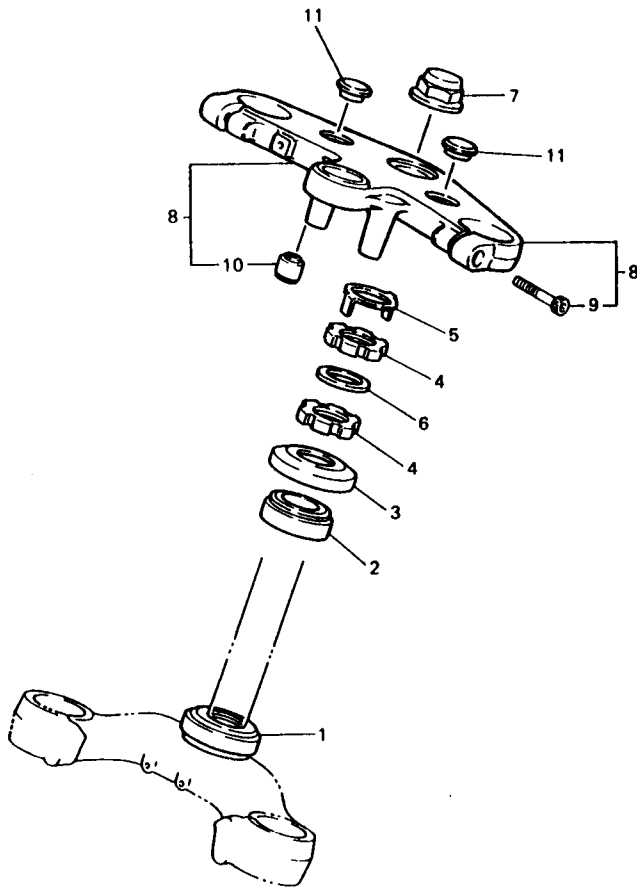

REF. NO.	PART NO.	DESCRIPTION	Q'TY	REMARKS
1	93332-00008	BEARING	1	
2	93332-00001	BEARING	1	
3	3GM-23415-00	COVER, BALL RACE 1	1	
4	90179-25033	NUT	2	
5	26H-23418-01	WASHER, SPECIAL	1	
6	90202-26142	WASHER, PLATE	1	
7	90176-22050	NUT, CROWN	1	
8	3GM-Y2343-30	CROWN, HANDLE	1	
9	91311-08030	.BOLT	2	
10	1UF-27414-00	.DAMPER, FOOTREST	2	
11	3GM-23437-00	COVER, CROWN	2	



3LE332-4280

D10

FIG. 27 FRONT FORK

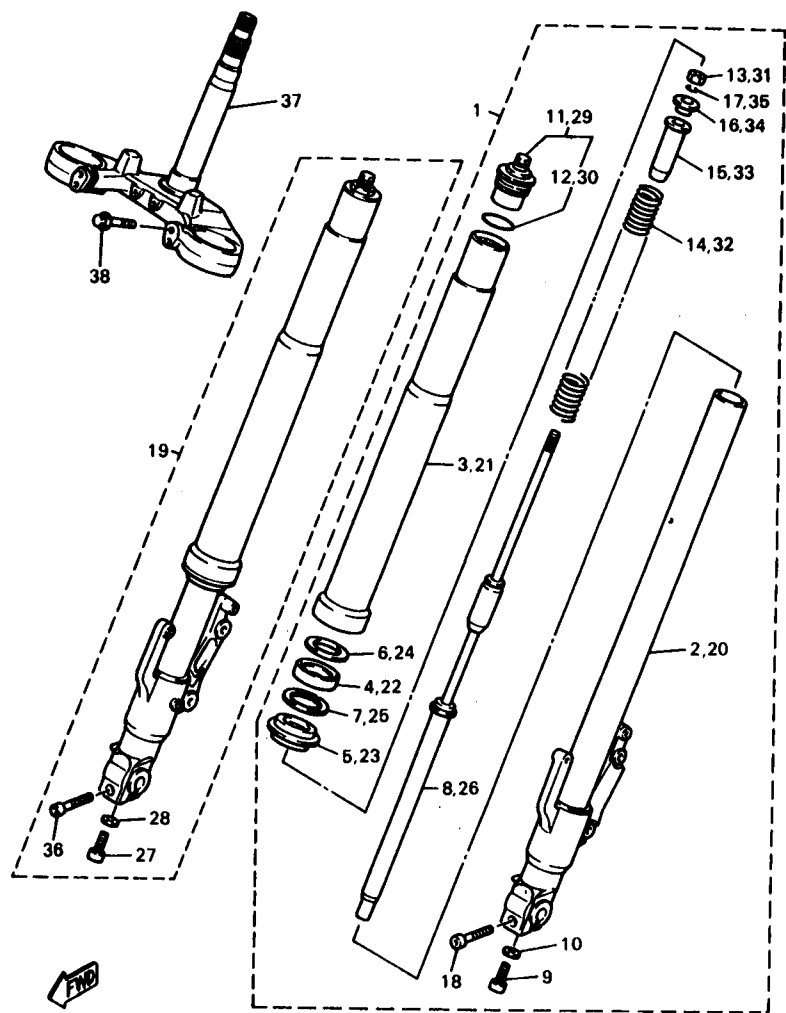

3LE332-4270

REF. NO.	PART NO.	DESCRIPTION	Q'TY	REMARKS
1	3GM-23102-A0	FRONT FORK ASSY (L.H)	1	
2	3GM-23110-A0	.INNER TUBE COMP.1	1	
3	3GM-23106-A0	.OUTER TUBE COMP. (L.H)	1	
4	3GM-23145-A0	.OIL SEAL	1	
5	3VD-23144-00	.SEAL, DUST	1	
6	3VD-23115-00	.GUIDE, COVER UPPER	1	
7	93450-52134	.CIRCLIP	1	
8	3GM-23170-A0	.CYLINDER COMP., FRONT FORK	1	
9	91311-10025	.BOLT	1	
10	90430-10171	.GASKET	1	
11	3GM-23111-A0	.BOLT, CAP	1	
12	93210-16N52	..O-RING	1	
13	95307-10800	.NUT	1	
14	3GM-23141-A0	.SPRING, FRONT FORK	1	
15	3GM-23117-A0	.GUIDE, SPRING	1	
16	3GM-2331K-A0	.SEAT, SPRING	1	
17	3GM-23153-A0	.RING, SNAP	1	
18	91311-08040	.BOLT	1	
19	3GM-23103-A0	FRONT FORK ASSY (R.H)	1	
20	3GM-23120-A0	.INNER TUBE COMP.2	1	
21	3GM-23106-A0	.OUTER TUBE COMP. (L.H)	1	
22	3GM-23145-A0	.OIL SEAL	1	
23	3VD-23144-00	.SEAL, DUST	1	
24	3VD-23115-00	.GUIDE, COVER UPPER	1	
25	93450-52134	.CIRCLIP	1	
26	3GM-23170-A0	.CYLINDER COMP., FRONT FORK	1	
27	91311-10025	.BOLT	1	
28	90430-10171	.GASKET	1	

FIG. 27 FRONT FORK

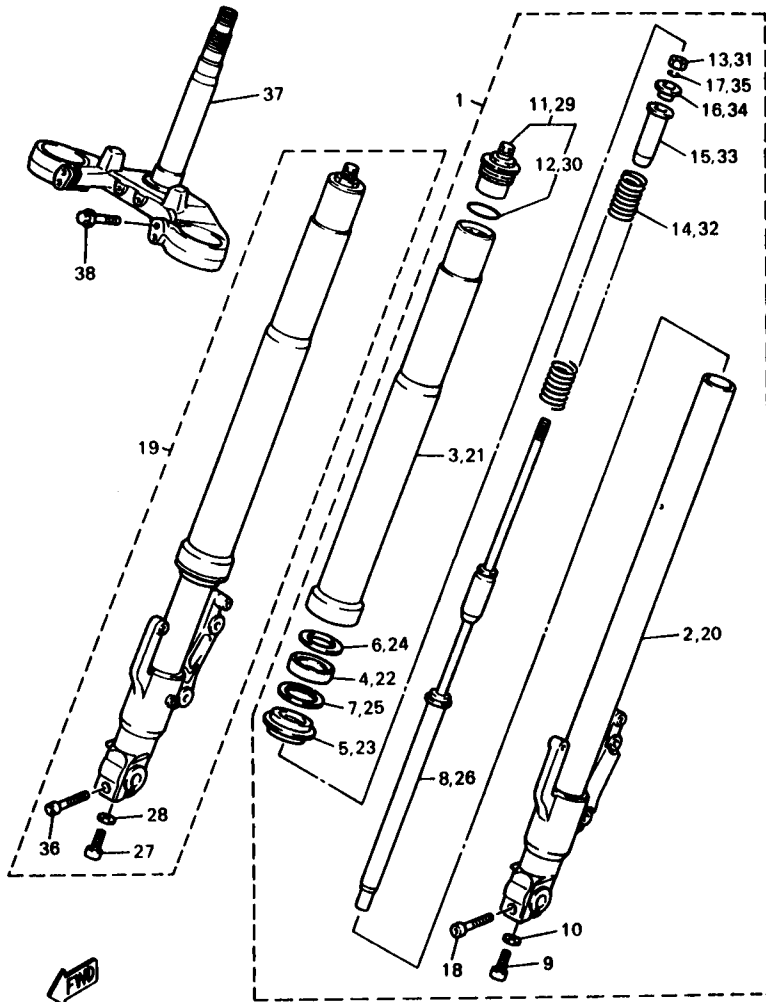

REF. NO.	PART NO.	DESCRIPTION	Q'TY	REMARKS
29	3GM-23111-A0	.BOLT, CAP	1	
30	93210-16N52	..O-RING	1	
31	95307-10800	.NUT	1	
32	3GM-23141-A0	.SPRING, FRONT FORK	1	
33	3GM-23117-A0	.GUIDE, SPRING	1	
34	3GM-2331K-A0	.SEAT, SPRING	1	
35	3GM-23153-A0	.RING, SNAP	1	
36	91311-08040	.BOLT	1	
37	3GM-23340-A0	UNDER BRACKET COMP.	1	
38	95827-08035	BOLT, FLANGE	4	

3LE332-4270

FIG. 28 FUEL TANK

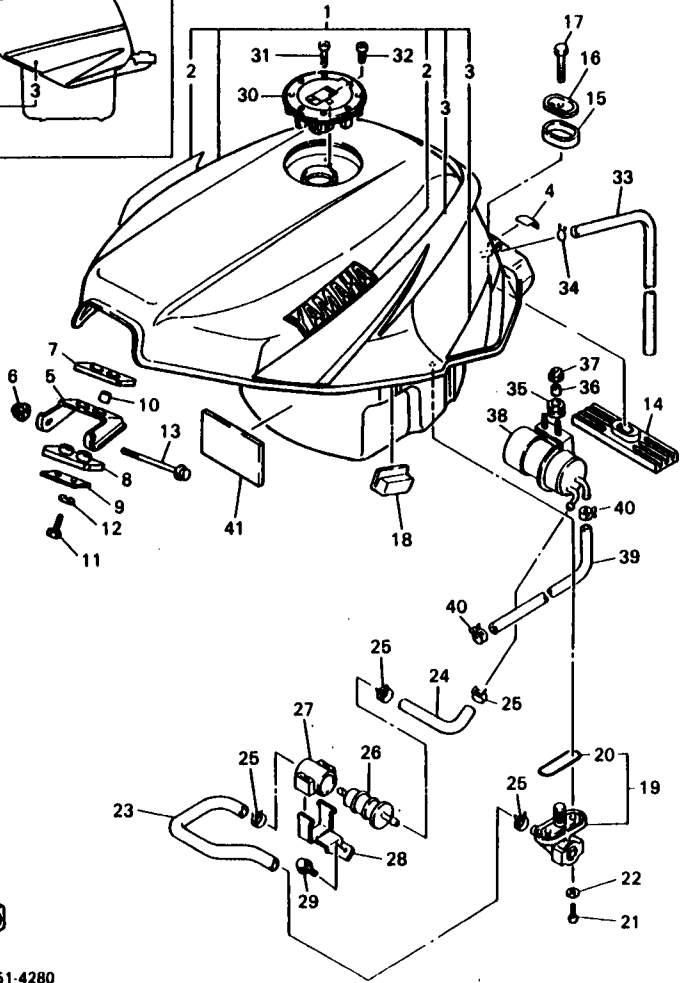
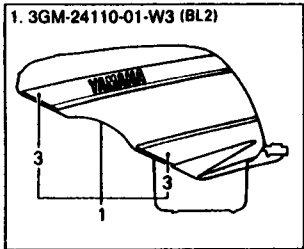

3LF351-4280

REF. NO.	PART NO.	DESCRIPTION	Q'TY	REMARKS
1	3GM-24110-01-W2	FUEL TANK COMP.	1	UR BLUSH WHITE COCKTAIL 1 /DEEP PURPLE METALLIC
	3GM-24110-01-W3	FUEL TANK COMP.	1	UR BLACK 2
2	99226-00140	.EMBLEM, YAMAHA	2	FOR BWC1
3	3LE-24240-01	.GRAPHIC SET	1	UR FOR BWC1
	3LE-24240-10	.GRAPHIC SET	1	UR FOR BL2
4	2GH-21732-00	SEAL 1	1	
5	2GH-24191-00	BRACKET, FUEL TANK 1	1	
6	90176-08072	NUT, CROWN	1	
7	2GH-24181-00	DAMPER, LOCATING 1	1	
8	2GH-24183-00	DAMPER, LOCATING 3	1	
9	2GH-24186-00	WASHER, SPECIAL	1	
10	90387-06299	COLLAR	2	
11	97011-08025	BOLT	2	
12	92995-08100	WASHER, SPRING	2	
13	95814-08075	BOLT, FLANGE	1	
14	2GH-24184-00	DAMPER, LOCATING 4	1	
15	3Y6-24183-00	DAMPER, LOCATING 3	1	
16	2GH-24187-00	WASHER, SPECIAL	1	
17	97011-08030	BOLT	1	
18	3GM-24182-01	DAMPER, LOCATING 2	2	
19	26H-24500-00	FUEL COCK ASSY 1	1	
20	214-24512-00	.GASKET	1	
21	90149-08011	SCREW	2	
22	90202-05187	WASHER, PLATE	2	
23	3GM-24311-01	PIPE, FUEL 1	1	
24	3GM-24312-00	PIPE 2	1	
25	90467-12124	CLIP	4	
26	1FK-24580-00	FILTER ASSY	1	

FIG. 28 FUEL TANK

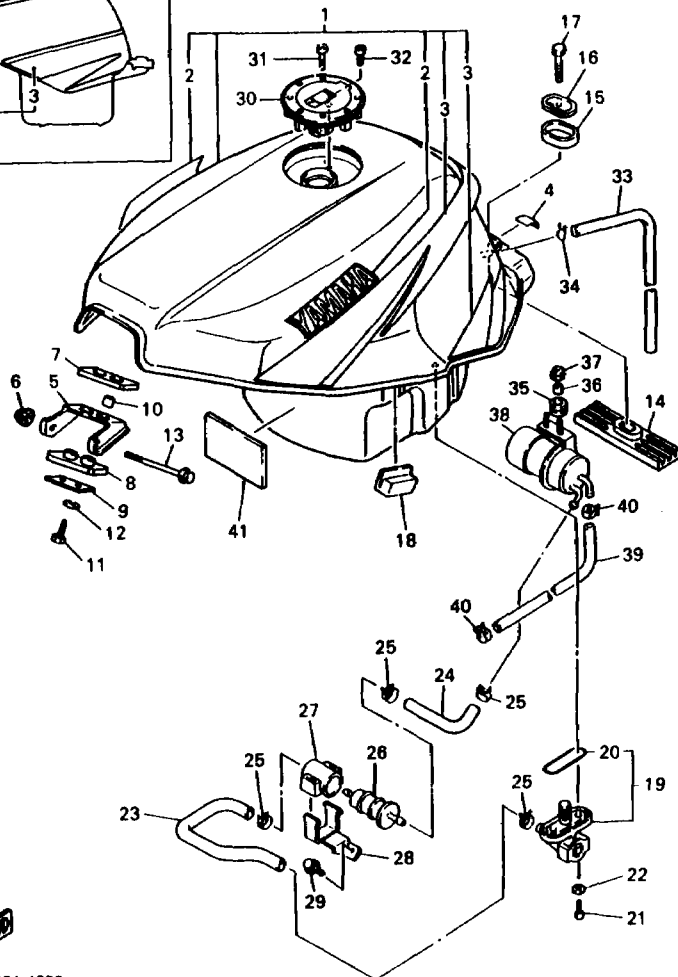
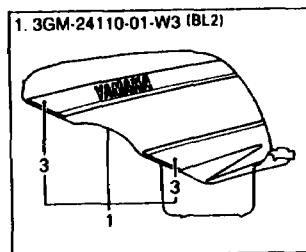

REF. NO.	PART NO.	DESCRIPTION	Q'TY	REMARKS
27	1FK-24566-00	BRACKET, FILTER	1	
28	3GM-24136-00	CLAMP 2	1	
29	95811-06012	BOLT, FLANGE	1	
30	4FM-24602-00	CAP ASSY	1	
31	90110-05112	BOLT, HEXAGON SOCKET HEAD	3	
32	91311-05010	BOLT	1	
33	90445-102G7	HOSE	1	
34	90467-09006	CLIP	1	
35	90480-13163	GROMMET	2	
36	90387-062L2	COLLAR	2	
37	95701-06500	NUT, FLANGE	2	
38	3GM-13907-00	FUEL PUMP COMP.	1	
39	3GM-14294-00	HOSE	1	
40	90467-13123	CLIP	2	
41	3Y6-21747-00	DAMPER	1	

3LF351-4280

FIG. 29 SEAT

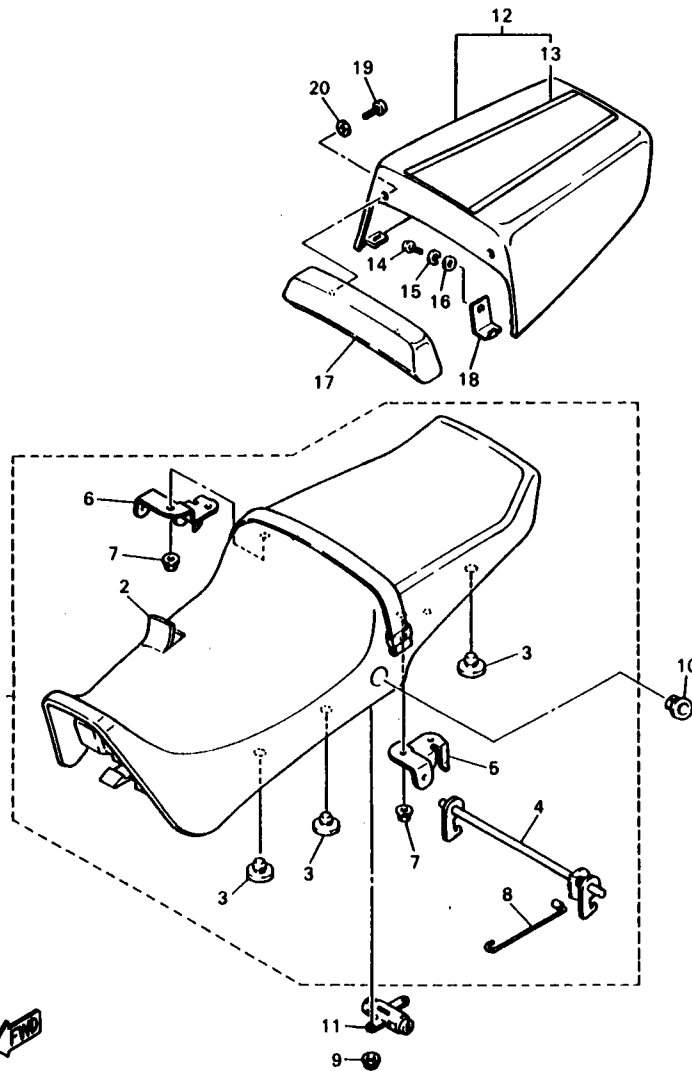

REF. NO.	PART NO.	DESCRIPTION	Q'TY	REMARKS
1	3GM-24730-50	DOUBLE SEAT ASSY	1	
2	3GM-24731-50	.COVER, SEAT	1	
3	2GH-24741-00	.PAD, SEAT	6	
4	3GM-24776-50	.LEVER, SEAT	1	
5	3GM-24718-50	.BRACKET, SEAT	1	
6	3GM-24728-50	.BRACKET, SEAT	1	
7	95701-06500	.NUT, FLANGE	4	
8	1KT-2478F-00	.ROD, CONNECTING	1	
9	95701-06500	NUT, FLANGE	2	
10	3GM-24798-50	COVER	1	
11	4BH-24705-00	SEAT LOCK ASSY	1	
12	3GM-W247A-F0-P0	COVER, SEAT	1	UR BLuish WHITE COCKTAIL 1 FOR EUROPE
	3GM-W247A-G0-4B	COVER, SEAT	1	UR BLACK 2 FOR EUROPE
13	3LE-2478M-00	.GRAPHIC, SEAT	1	UR FOR BWC1 FOR EUROPE
	3LE-2478M-10	.GRAPHIC, SEAT	1	UR FOR BL2 FOR EUROPE
14	98580-08010	SCREW, PAN HEAD	2	FOR EUROPE
15	92995-08100	WASHER, SPRING	2	FOR EUROPE
16	92990-08600	WASHER, PLATE	2	FOR EUROPE
17	3GM-2840F-50	BACK REST ASSY	1	FOR EUROPE
18	3GM-24718-00	BRACKET, SEAT	2	FOR EUROPE
19	98511-08012	SCREW, PAN HEAD	2	FOR EUROPE
20	92990-08200	WASHER, PLAIN	2	FOR EUROPE



3LE332-4280

FIG. 30 FRONT WHEEL

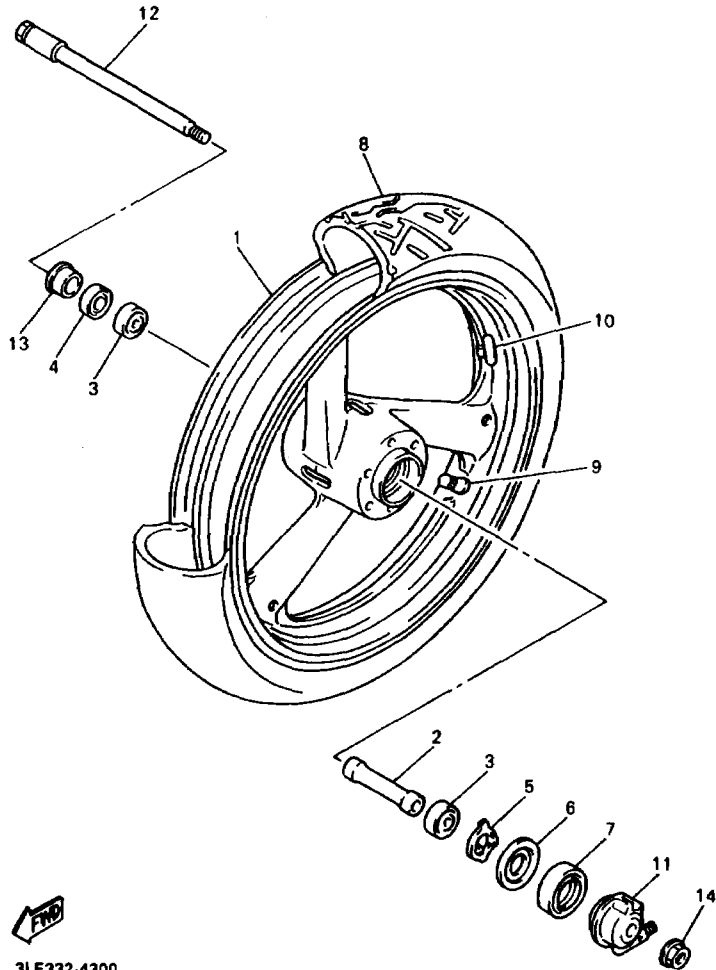

3LE332-4300

REF. NO.	PART NO.	DESCRIPTION	Q'TY	REMARKS
1	4FM-25188-00-P2	CAST WHEEL, FRONT	1	UR DEEP REDDISH PURPLE SOLID 1 FOR BWC1
	4FM-25188-00-7B	CAST WHEEL, FRONT	1	UR BLUISH BLACK 2 FOR BL2
2	90387-2200S	COLLAR	1	
3	93306-00420	BEARING (B8004)	2	
4	93102-28021	OIL SEAL	1	
5	4FM-25149-00	CLUTCH, METER	1	
6	341-25846-00	RETAINER, CLUTCH	1	
7	93105-45017	OIL SEAL	1	
8	*	TIRE (130/60 ZR17 A59)	1	UR LM MICHELIN
	94113-174U1	TIRE (130/60 VR17 V280)	1	UR DUNLOP
	*	TIRE (130/60 VR17 V280)	1	UR LM PIRELLI
9	93900-00030	VALVE, RIM	1	
10	29L-25398-00	BALANCER, WHEEL (10G)	1	UN
	29L-25398-10	BALANCER, WHEEL (20G)	1	UN
	29L-25398-20	BALANCER, WHEEL (30G)	1	UN
11	4FM-25190-00	GEAR UNIT ASSY	1	
12	3GM-25181-A0	AXLE, WHEEL	1	
13	90387-2200T	COLLAR	1	
14	90179-18332	NUT	1	

FIG. 31 FRONT BRAKE CALIPER

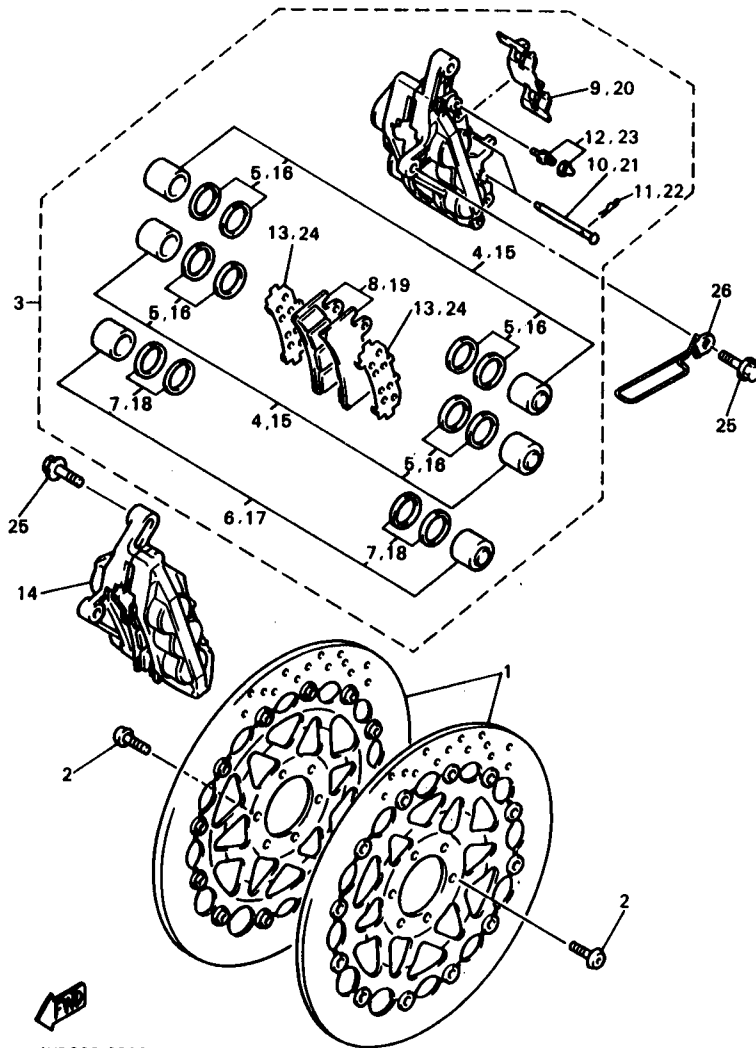

4HD300-3300

REF. NO.	PART NO.	DESCRIPTION	Q'TY	REMARKS
1	4FM-2581T-01	DISC BRAKE ASSY	2	
2	90109-08718	BOLT	12	
3	4FM-2580T-20	CALIPER ASSY (LEFT)	1	
4	4FM-W0057-10	.PISTON ASSY, CALIPER	2	
5	3MA-W0047-10	..CALIPER SEAL KIT	1	
6	4FM-W0057-00	.PISTON ASSY, CALIPER	1	
7	4FM-W0047-00	..CALIPER SEAL KIT	1	
8	4FM-W0045-20	.BRAKE PAD KIT	1	
9	4FM-25919-00	.SUPPORT, PAD	1	
10	4FM-25924-00	.PIN, PAD	2	
11	4FM-25925-00	.CLIP	2	
12	1J3-W0048-00	.BREED SCREW KIT	1	
13	4FM-25827-00	.SHIM, CALIPER	2	
14	4FM-2580U-20	CALIPER ASSY (RIGHT)	1	
15	4FM-W0057-10	.PISTON ASSY, CALIPER	2	
16	3MA-W0047-10	..CALIPER SEAL KIT	1	
17	4FM-W0057-00	.PISTON ASSY, CALIPER	1	
18	4FM-W0047-00	..CALIPER SEAL KIT	1	
19	4FM-W0045-20	.BRAKE PAD KIT	1	
20	4FM-25919-00	.SUPPORT, PAD	1	
21	4FM-25924-00	.PIN, PAD	2	
22	4FM-25925-00	.CLIP	2	
23	1J3-W0048-00	.BREED SCREW KIT	1	
24	4FM-25827-00	.SHIM, CALIPER	2	
25	90105-10838	BOLT, WASHER BASED	4	
26	4FM-21596-00	HOLDER	1	

FIG. 32 REAR WHEEL

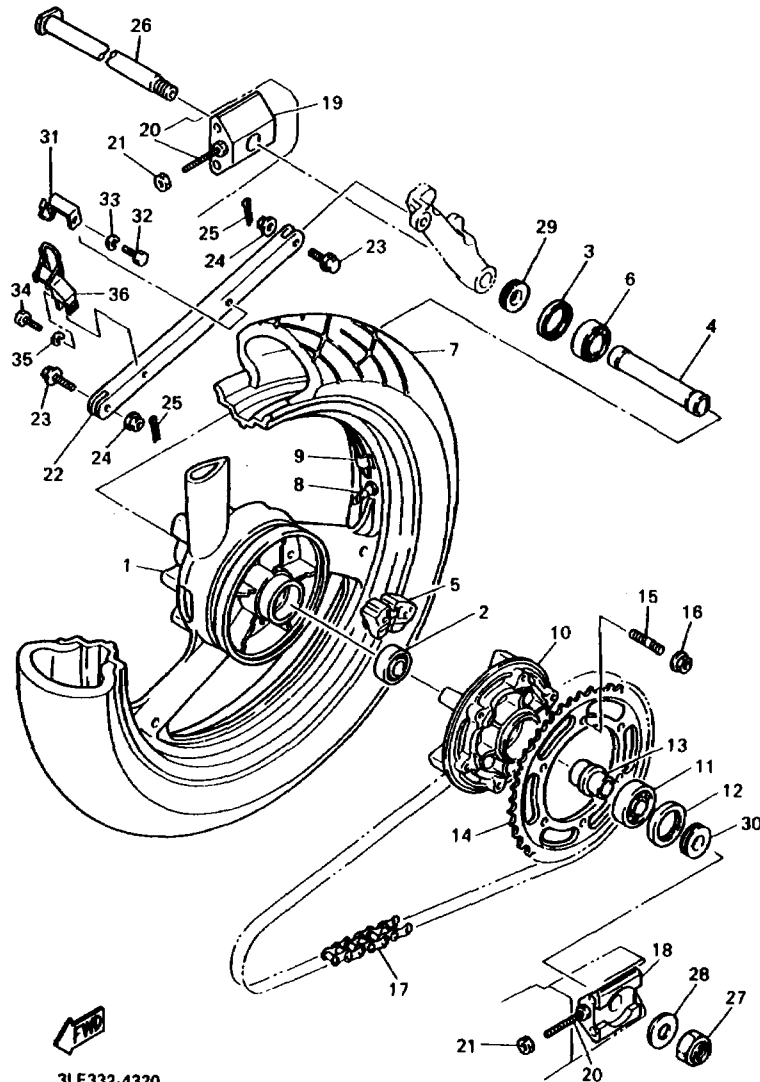

3LE332-4320

REF. NO.	PART NO.	DESCRIPTION	Q'TY	REMARKS
1	3GM-25338-01-P0	CAST WHEEL, REAR	1	UR DEEP REDDISH PURPLE SOLID 1 FOR BWC1
	3GM-25338-01-7B	CAST WHEEL, REAR	1	UR BLUISH BLACK 2 FOR BL2
2	93306-30416	BEARING (B6304RS)	1	
3	93106-30029	OIL SEAL	1	
4	90560-20357	SPACER	1	
5	2GH-25364-00	DAMPER	5	
6	93306-30437	BEARING	1	
7	*	TIRE (170/60 ZR17 M59)	1	UR LM MICHELIN
	94117-173U6	TIRE (170/60 VR17 V280)	1	UR DUNLOP
	*	TIRE (170/60 VR17 V280)	1	UR LM PIRELLI
8	93900-00030	VALVE, RIM	1	
9	29L-25398-00	BALANCER, WHEEL (10G)	1	UN
	29L-25398-10	BALANCER, WHEEL (20G)	1	UN
	29L-25398-20	BALANCER, WHEEL (30G)	1	UN
10	36Y-25366-01	CLUTCH, HUB	1	
11	93306-30562	BEARING	1	
12	93106-35030	OIL SEAL	1	
13	36Y-25377-00	COLLAR, WHEEL	1	
14	2GH-25447-22	SPROCKET, DRIVEN (47T)	1	
15	90116-10485	BOLT, STUD	6	
16	95601-10200	NUT, SELF-LOCKING	6	
17	94581-57110	CHAIN (DID532ZLVKA1-110L)	1	UR DAIDO
	94571-31110	CHAIN (RK532GSV2-110L)	1	UR TAKASAGO
18	3GM-25388-00	PULLER, CHAIN 1	1	
19	3GM-25389-00	PULLER, CHAIN 2	1	
20	90101-08766	BOLT	2	
21	95307-08600	NUT	2	
22	3GM-25371-00	BAR, TENSION	1	

FIG. 32 REAR WHEEL

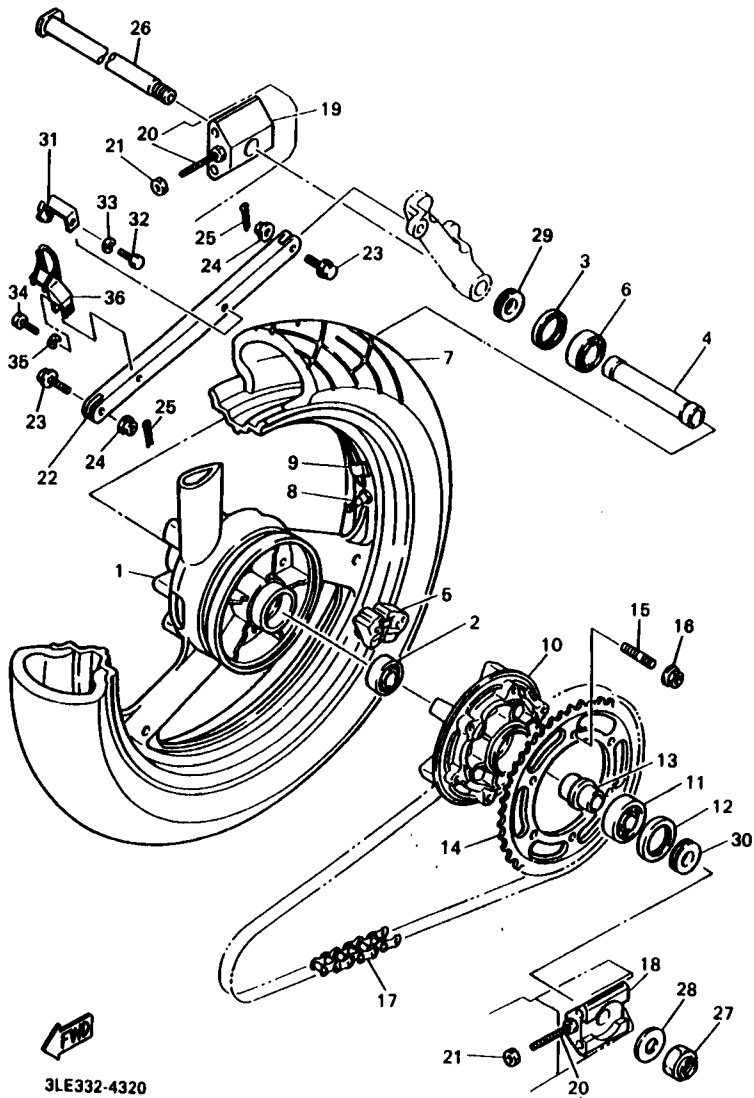

REF. NO.	PART NO.	DESCRIPTION	Q'TY	REMARKS
23	90105-08321	BOLT, WASHER BASED	2	
24	95701-08500	NUT, FLANGE	2	
25	91490-20020	PIN, COTTER	2	
26	3GM-25381-A0	AXLE, WHEEL	1	
27	95601-18200	NUT, SELF-LOCKING	1	
28	90201-18264	WASHER, PLATE	1	
29	90387-202X9	COLLAR	1	
30	90387-203X0	COLLAR	1	
31	3GM-25876-00	HOLDER, BRAKE HOSE 2	1	
32	97011-06010	BOLT	1	
33	92995-06100	WASHER, SPRING	1	
34	97021-06030	BOLT	1	
35	92995-06100	WASHER, SPRING	1	
36	3GM-25876-50	HOLDER, BRAKE HOSE 1	1	

FWD
3LE332-4320

FIG. 33 REAR BRAKE CALIPER

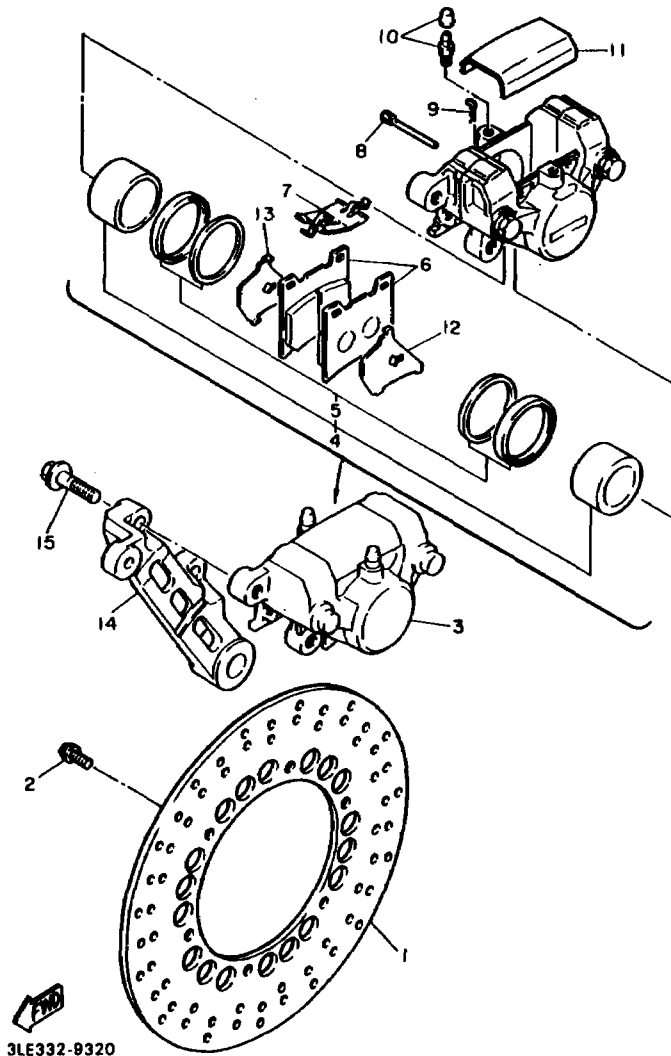

REF. NO.	PART NO.	DESCRIPTION	Q'TY	REMARKS
1	2KT-25831-00	DISC, BRAKE (RIGHT)	1	
2	90109-08718	BOLT	6	
3	3GM-2580W-10	CALIPER ASSY, REAR 2	1	
4	31A-W0057-00	.PISTON ASSY, CALIPER	1	
5	31A-W0047-00	..CALIPER SEAL KIT	1	
6	26H-W0045-11	.BRAKE PAD KIT	1	
7	29L-25919-A0	.SUPPORT, PAD	1	
8	3HE-25924-00	.PIN, PAD	2	
9	3HE-25925-00	.CLIP	2	
10	1J3-W0048-00	.BREED SCREW KIT	2	
11	51J-25836-00	.COVER, DUST	1	
12	1FK-25827-00	.SHIM, CALIPER	1	
13	1FK-25828-00	.SHIM, CALIPER	1	
14	3GM-25819-00	BRACKET, CALIPER	1	
15	90105-10638	BOLT, WASHER BASED	2	

FIG. 34 STEERING HANDLE • CABLE

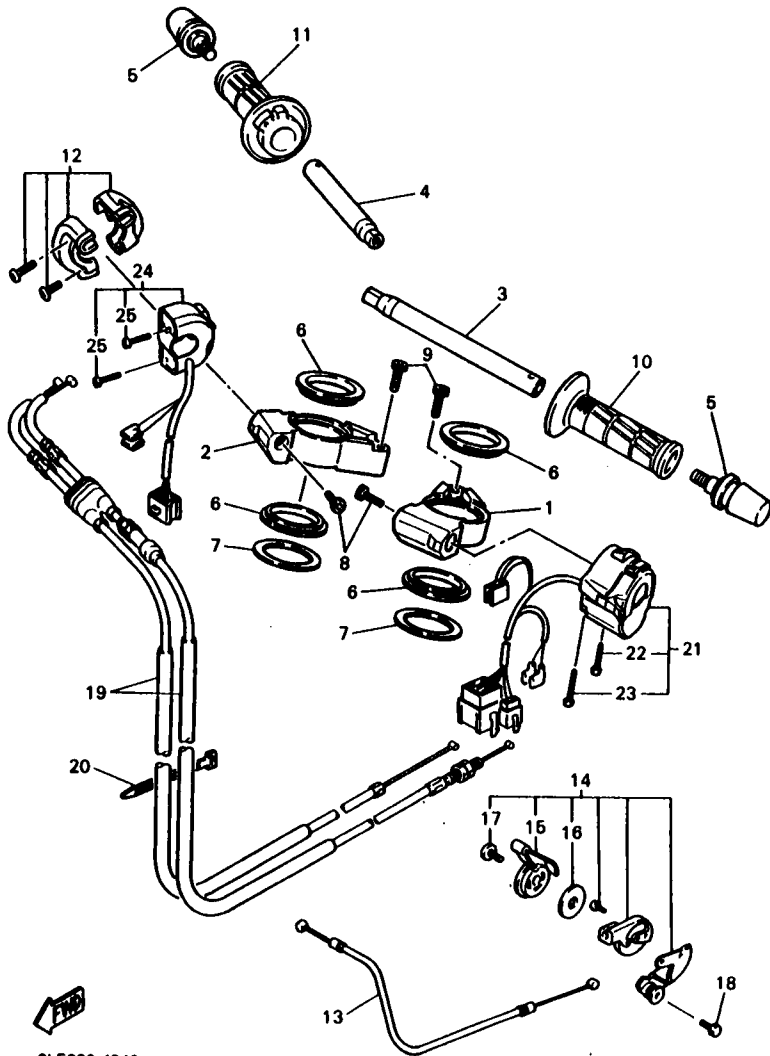

3LE332-4340

REF. NO.	PART NO.	DESCRIPTION	Q'TY	REMARKS
1	3GM-26121-51	HANDLEBAR (LEFT)	1	
2	3GM-26122-51	HANDLEBAR (RIGHT)	1	
3	3GM-26111-A0	HANDLEBAR	1	
4	3GM-26112-A0	BAR, HANDLE	1	
5	36Y-26246-00	END, GRIP	2	
6	3GM-26113-50	DAMPER	4	
7	90201-502P8	WASHER, PLATE	2	
8	91311-08025	BOLT	2	
9	90109-082A1	BOLT	2	
10	4FM-26241-00	GRIP (LEFT)	1	
11	4FM-26240-00	GRIP ASSY	1	
12	3LN-26270-01	CABLE CONNECTOR CAP ASSY	1	
13	3GM-26331-01	CABLE, STARTER 1	1	
14	3GM-83940-00	STARTER ASSY	1	
15	1WG-83941-00	.LEVER, STARTER	1	
16	90209-10131	.WASHER	1	
17	98906-06008	.SCREW, BIND	1	
18	91316-06012	BOLT	1	
19	3GM-26302-00	THROTTLE CABLE ASSY	1	
20	437-83936-11	BAND, SWITCH CORD	1	
21	3GM-83969-01	SWITCH, HANDLE 5	1	UR
	3LJ-83972-00	SWITCH, HANDLE 4	1	UR FOR OCEANIA
22	98506-06030	.SCREW, PAN HEAD	1	
23	98506-06040	.SCREW, PAN HEAD	1	
24	4HM-83975-00	SWITCH, HANDLE 2	1	
25	90167-06057	.SCREW, PAN HEAD	2	

FIG. 35 FRONT MASTER CYLINDER

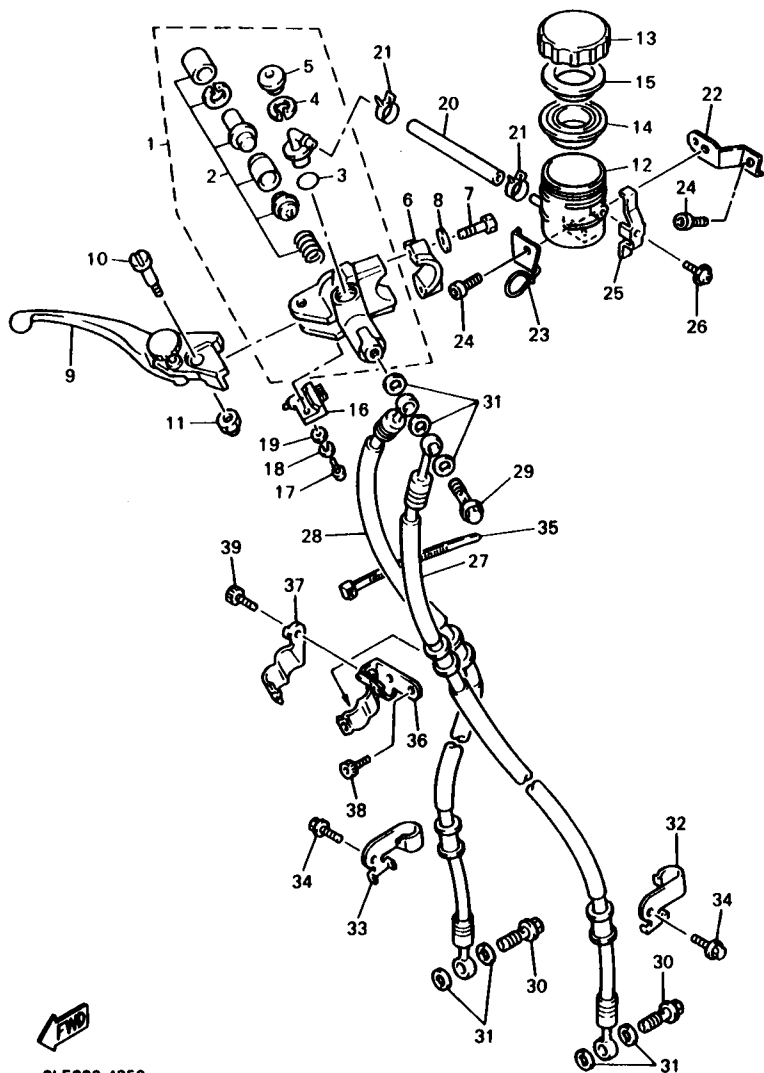

3LE332-4350

REF. NO.	PART NO.	DESCRIPTION	Q'TY	REMARKS
1	3GM-W2587-50	MASTER CYLINDER SUB ASSY	1	
2	3GM-W0041-50	.CYLINDER KIT, MASTER	1	
3	93210-15620	.O-RING	1	
4	2VN-25868-00	.CIRCLIP	1	
5	3FV-2589A-00	.COVER, DUST	1	
6	56A-25867-00	BRACKET, MASTER CYLINDER	1	
7	97016-08025	BOLT	2	
8	92906-08600	WASHER, PLATE	2	
9	3GM-83922-50	LEVER 2	1	
10	3FV-2589F-00	BOLT, LEVER	1	
11	95616-06100	NUT, U	1	
12	3FV-25894-00	TANK, RESERVOIR	1	
13	3GM-25852-50	CAP, RESERVOIR	1	
14	3FV-25854-00	DIAPHRAGM, RESERVOIR	1	
15	2J2-25855-50	BUSH,DIAPHRAGM	1	
16	3FV-83980-00	FRONT STOP SWITCH ASSY	1	
17	98511-04012	SCREW, PAN HEAD	1	
18	92990-04100	WASHER, SPRING	1	
19	92901-04600	WASHER, PLATE	1	
20	3GM-2585F-00	HOSE	1	
21	3PA-24358-00	CLIP, PIPE 1	2	
22	3GM-26292-50	STAY	1	
23	3GM-26131-00	GUIDE, CABLE 1	1	
24	90110-06145	BOLT, HEXAGON SOCKET HEAD	2	
25	3FV-2589G-00	HOLDER	1	
26	3GM-2588H-00	SCREW, WITH WASHER	1	
27	3GM-25872-A0	HOSE, BRAKE 1	1	
28	3GM-25873-A0	HOSE, BRAKE 2	1	

FIG. 35 FRONT MASTER CYLINDER

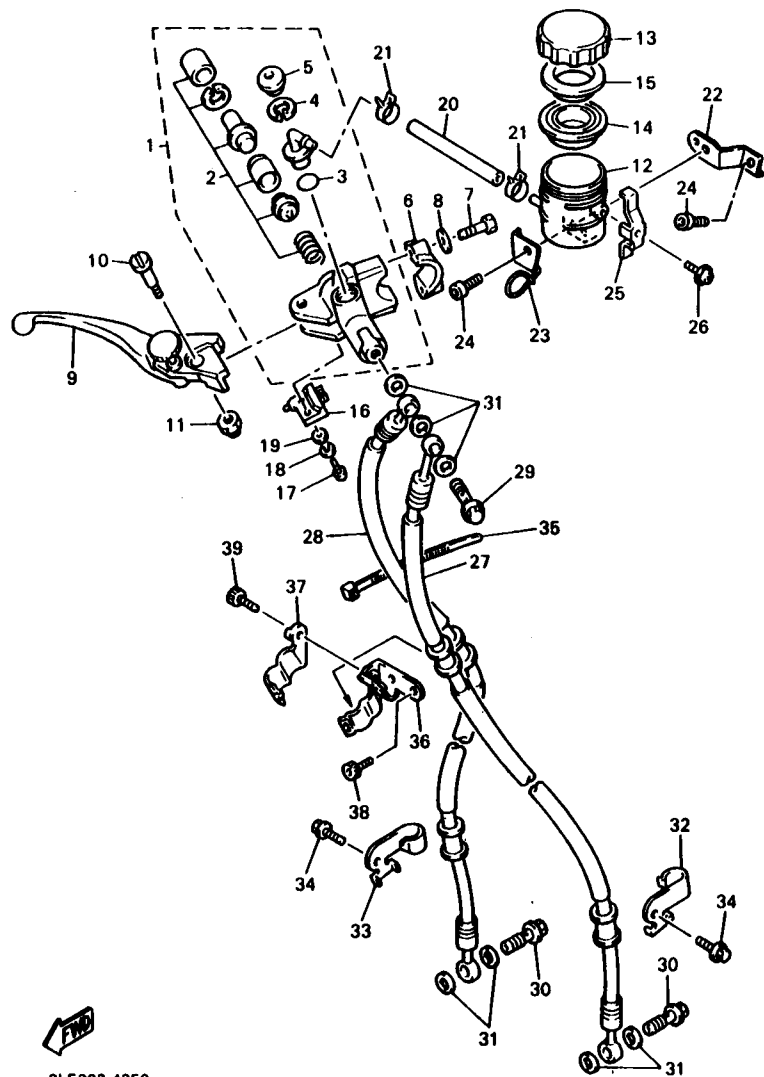

REF. NO.	PART NO.	DESCRIPTION	Q'TY	REMARKS
29	90401-10160	BOLT, UNION	1	
30	90401-10159	BOLT, UNION	2	
31	90201-10118	WASHER, PLATE	7	
32	3MA-25876-11	HOLDER, BRAKE HOSE 2	1	
33	3MA-25876-21	HOLDER, BRAKE HOSE 2	1	
34	95816-06012	BOLT, FLANGE	2	
35	3MA-82591-00	BAND	1	
36	3GM-23377-00	BRACKET, HORN	1	
37	3GM-23378-00	BRACKET	1	
38	91316-06012	BOLT	2	
39	91316-06010	BOLT	1	

3LE332-4350

FIG. 36 FRONT MASTER CYLINDER 2

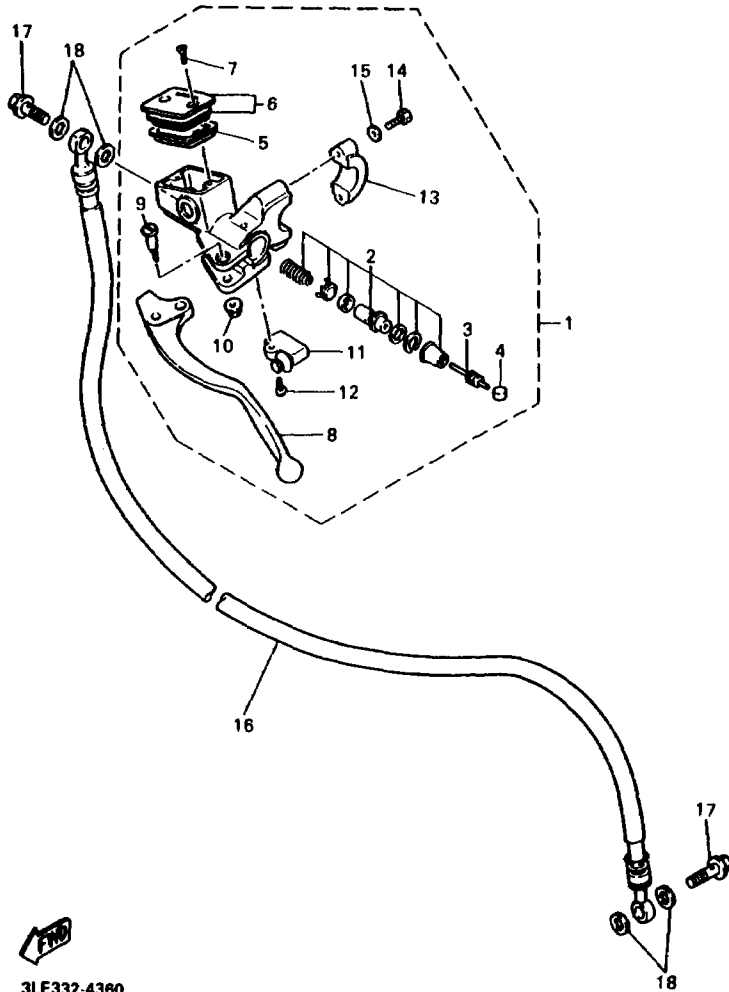

REF. NO.	PART NO.	DESCRIPTION	Q'TY	REMARKS
1	3GM-26450-A0	MASTER CYLINDER ASSY (CLUTCH)	1	
2	3GM-W0099-00	.CYLINDER KIT, MASTER (CLUTCH)	1	
3	3GM-26464-00	.ROD, PUSH	1	
4	3GM-26465-00	.BUSH	1	
5	55U-25854-00	.DIAPHRAGM, RESERVOIR	1	
6	3GM-W2585-20	.RESERVOIR CAP SET	1	
7	98706-04012	.SCREW, FLAT HEAD	2	
8	3GM-83912-10	.LEVER 1	1	
9	90149-06287	.SCREW	1	
10	95706-06500	.NUT, FLANGE	1	
11	3GM-83980-00	.FRONT STOP SWITCH ASSY	1	
12	98706-04016	.SCREW, FLAT HEAD	1	
13	56A-25867-00	.BRACKET, MASTER CYLINDER	1	
14	97016-06025	.BOLT	2	
15	92906-06600	.WASHER, PLATE	2	
16	3GM-26470-A0	HOSE, CLUTCH	1	
17	90401-10159	BOLT, UNION	2	
18	90201-10118	WASHER, PLATE	4	

3LE332-4360

E10

FIG. 37 STAND • FOOTREST

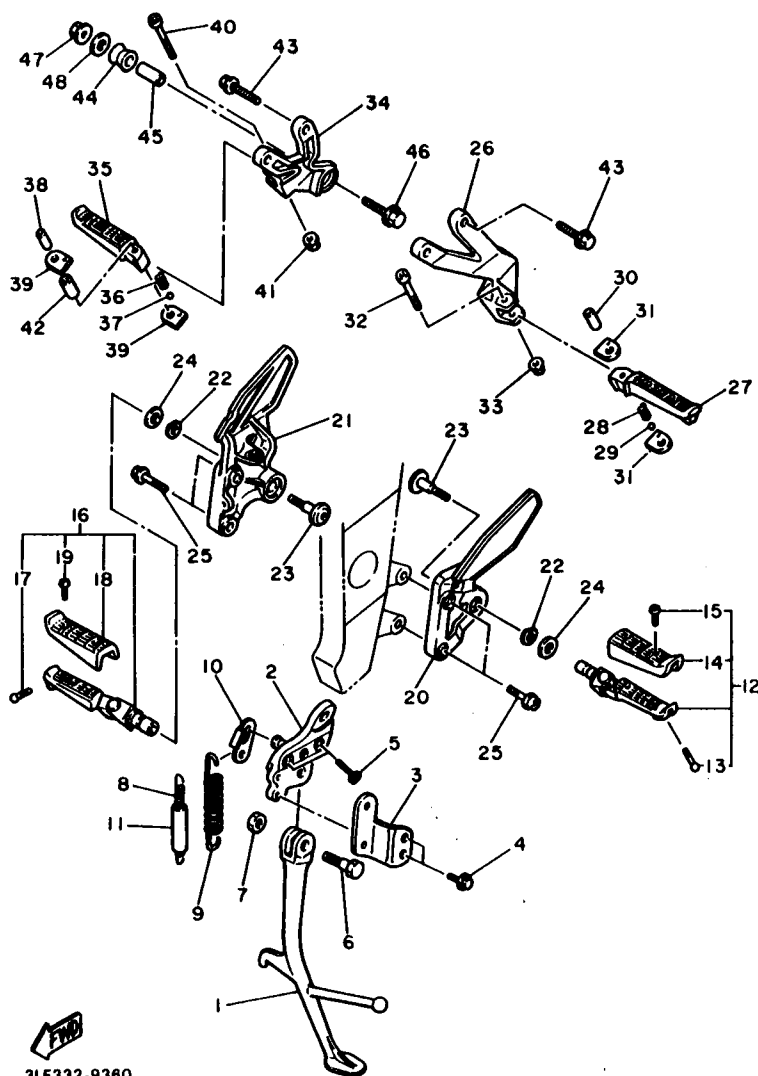

3LE332-9380

REF. NO.	PART NO.	DESCRIPTION	Q'TY	REMARKS
1	3GM-27311-00	STAND, SIDE	1	
2	3GM-27321-00	BRACKET, SIDE STAND	1	
3	3GM-21453-00	BRACKET, SWITCH	1	
4	90105-06664	BOLT, WASHER BASED	2	
5	90110-08155	BOLT, HEXAGON SOCKET HEAD	2	
6	90109-104E6	BOLT	1	
7	90185-10037	NUT, SELF-LOCKING	1	
8	90506-18224	SPRING, TENSION	1	
9	90506-28225	SPRING, TENSION	1	
10	2KT-27316-00	LINK, SIDE STAND	1	
11	1TX-27351-00	GUIDE, SIDE STAND	1	
12	2GH-27410-00	FRONT FOOTREST ASSY (LEFT)	1	
13	90109-083E2	.BOLT	1	
14	2GH-27413-00	.COVER, FOOTREST	1	
15	90157-05079	.SCREW, PAN HEAD	2	
16	2GH-27420-00	FRONT FOOTREST ASSY (RIGHT)	1	
17	90109-083E2	.BOLT	1	
18	2GH-27413-00	.COVER, FOOTREST	1	
19	90157-05079	.SCREW, PAN HEAD	2	
20	3GM-27442-00	BRACKET 2	1	
21	3GM-27443-00	BRACKET 3	1	
22	90214-10056	WASHER, CLAW	2	
23	90109-103A9	BOLT	2	
24	90206-17084	WASHER, WAVE	2	
25	90110-08199	BOLT, HEXAGON SOCKET HEAD	4	
26	3GM-2741L-00	BRACKET 4	1	
27	1HX-27431-00	FOOTREST, REAR 1	1	
28	90501-12743	SPRING, COMPRESSION	1	

FIG. 37 STAND • FOOTREST

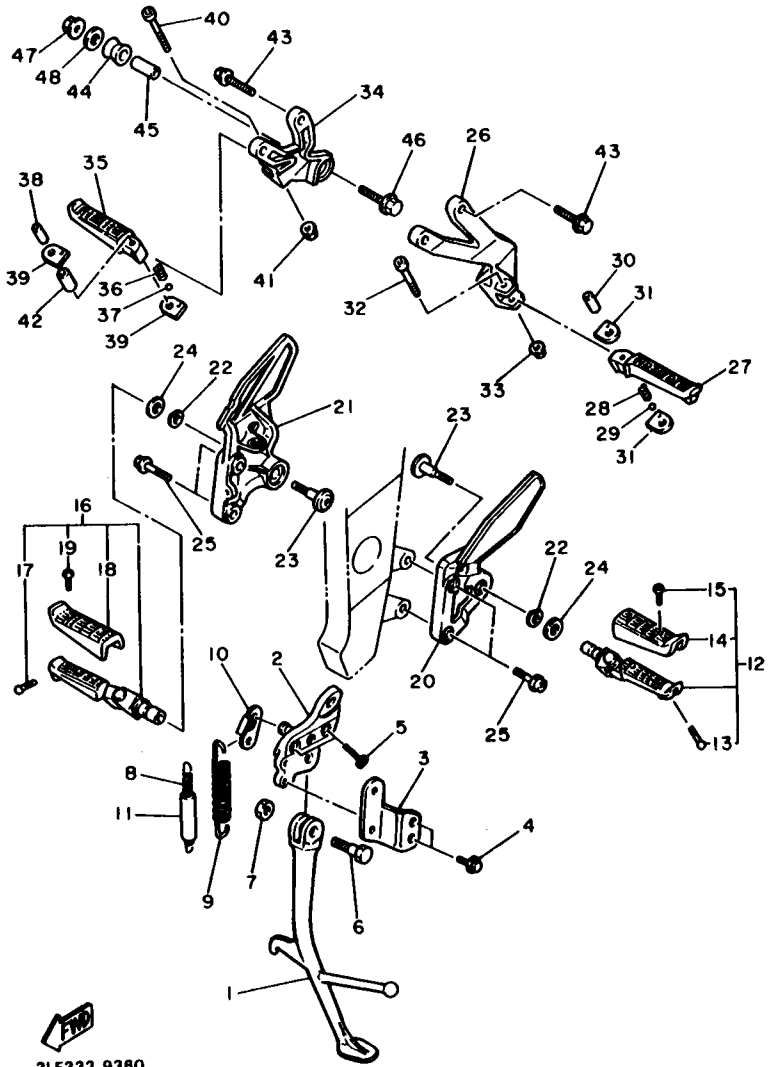

3LE332-9380

REF. NO.	PART NO.	DESCRIPTION	Q'TY	REMARKS
29	93501-04011	BALL	1	
30	90387-064H8	COLLAR	1	
31	1HX-27437-00	WASHER, SPECIAL	2	
32	91311-06045	BOLT	1	
33	95801-06100	NUT, U	1	
34	3GM-2742L-00	BRACKET 5	1	
35	3GM-27441-00	FOOTREST, REAR 2	1	
36	90501-12743	SPRING, COMPRESSION	1	
37	93501-04011	BALL	1	
38	90387-064H8	COLLAR	1	
39	1HX-27437-00	WASHER, SPECIAL	2	
40	91311-06045	BOLT	1	
41	95801-06100	NUT, U	1	
42	90387-083W8	COLLAR	1	
43	95821-08025	BOLT, FLANGE	4	
44	2H7-27414-00	DAMPER, FOOTREST	1	
45	90387-10636	COLLAR	1	
46	90105-10316	BOLT, WASHER BASED	1	
47	95701-10500	NUT, FLANGE	1	
48	90201-10669	WASHER, PLATE	1	

FIG. 38 REAR MASTER CYLINDER

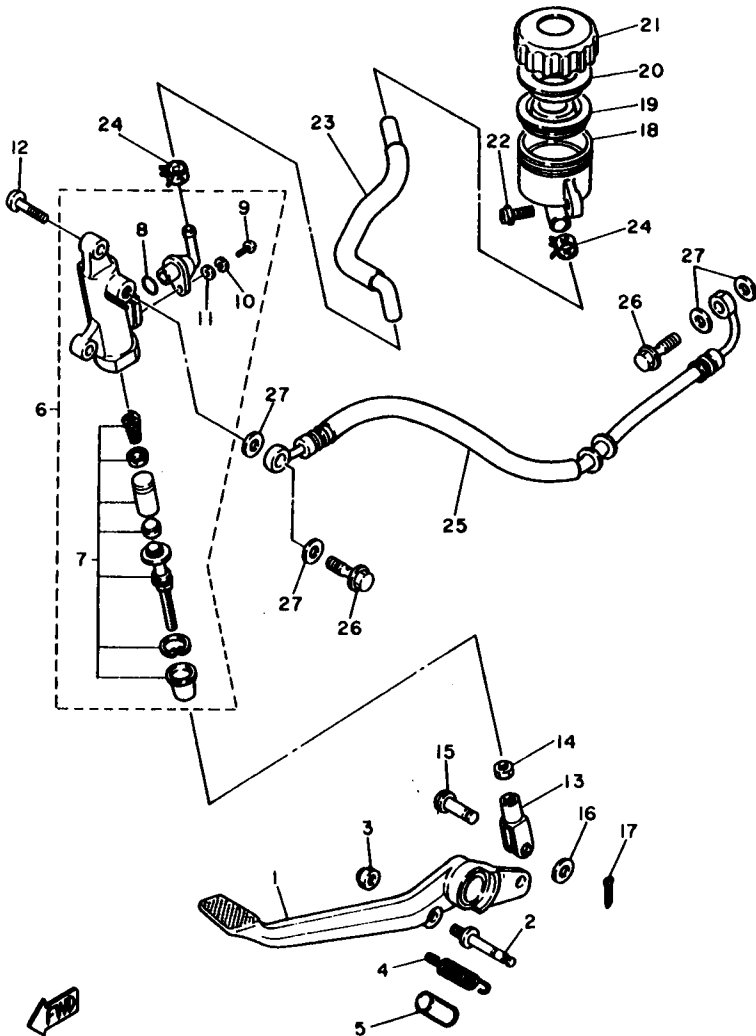

REF. NO.	PART NO.	DESCRIPTION	Q'TY	REMARKS
1	2GH-27211-00	PEDAL, BRAKE	1	
2	2TK-27813-00	PIN, PEDAL CRANK	1	
3	95611-08100	NUT, U	1	
4	90508-20737	SPRING, TORSION	1	
5	90448-17346	HOSE	1	
6	3GM-2583V-00	RR. MASTER CYLINDER ASSY.	1	
7	2KR-W0042-50	.CYLINDER KIT, MASTER	1	
8	93210-15620	.O-RING	1	
9	98511-04012	.SCREW, PAN HEAD	1	
10	92990-04100	.WASHER, SPRING	1	
11	92901-04600	.WASHER, PLATE	1	
12	92011-08030	BOLT, BUTTON HEAD	2	
13	47X-27222-00	JOINT	1	
14	95303-08700	NUT	1	
15	90240-08013	PIN, CLEVIS	1	
16	90201-08083	WASHER, PLATE	1	
17	91490-20020	PIN, COTTER	1	
18	47X-25894-00	TANK, RESERVOIR	1	
19	360-25854-00	DIAPHRAGM, RESERVOIR	1	
20	2GU-25855-00	BUSH, DIAPHRAGM	1	
21	2KF-25852-50	CAP, RESERVOIR	1	
22	90159-08033	SCREW, WITH WASHER	1	
23	3GM-25895-50	HOSE, RESERVOIR	1	
24	90467-14057	CLIP	2	
25	3GM-25874-A0	HOSE, BRAKE	1	
28	90401-10159	BOLT, UNION	2	
27	90201-10118	WASHER, PLATE	4	

3LE332-9370

FIG. 39 COWLING 1

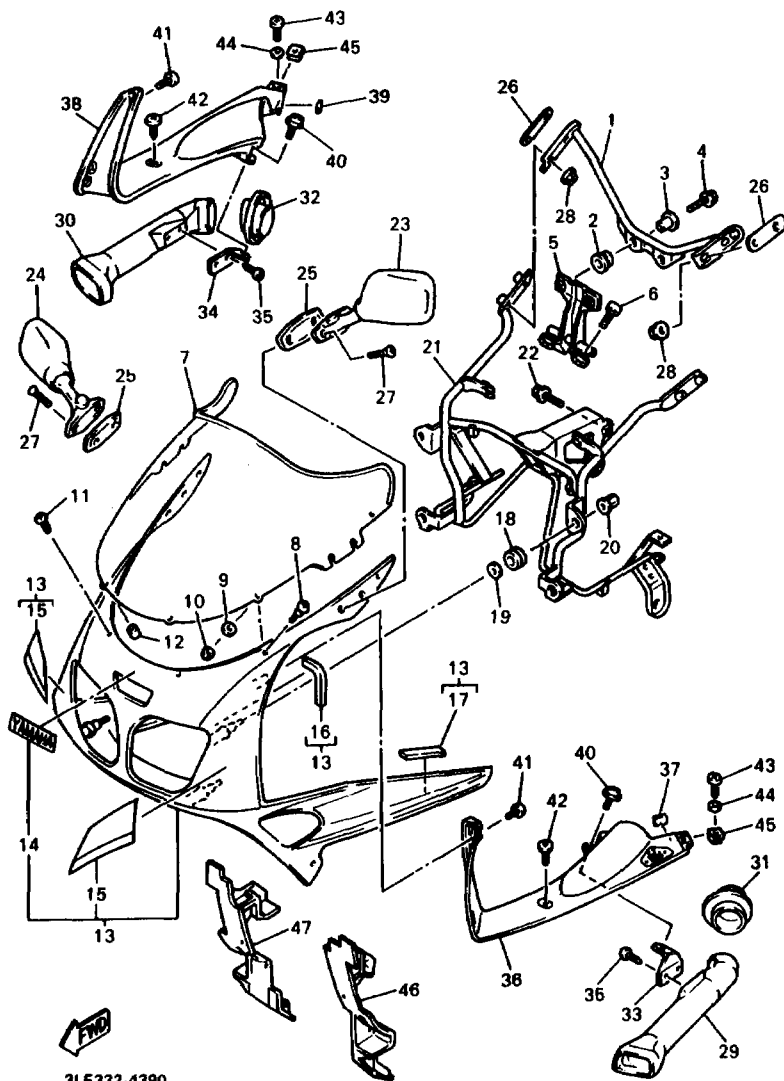

REF. NO.	PART NO.	DESCRIPTION	Q'TY	REMARKS
1	3GM-2831W-A0	STAY, MIRROR 1	1	
2	90480-13398	GROMMET	2	
3	90387-067N6	COLLAR	2	
4	95026-06016	BOLT, FLANGE	2	
5	3GM-2832W-A0	STAY, MIRROR 2	1	
6	91316-06016	BOLT	2	
7	3GM-28381-A0	WINDSHIELD	1	
8	90149-05273	SCREW	4	
9	4FM-28215-00	WASHER, SPECIAL	4	
10	95706-05500	NUT, FLANGE	4	
11	90150-05023	SCREW, ROUND HEAD	2	
12	90179-05523	NUT	2	
13	3GM-Y283G-J0-0X	BODY, FRONT UPPER 1	1	UR BLUSH WHITE COCKTAIL 1 /DEEP PURPLE METALLIC
	3GM-Y283G-K0-4B	BODY, FRONT UPPER 1	1	UR BLACK 2
14	99236-00100	.EMBLEM, YAMAHA	1	UR FOR BWC1
	99237-00100	.EMBLEM, YAMAHA	1	UR FOR BL2
15	3LE-28390-01	.GRAPHIC SET, COWLING	1	UR FOR BWC1
	3LE-28390-11	.GRAPHIC SET, COWLING	1	UR FOR BL2
16	3MA-21649-00	.DAMPER	2	
17	1FK-83526-00	.DAMPER 2	2	
18	90480-14229	GROMMET	4	
19	90201-08759	WASHER, PLATE	4	
20	90179-06499	NUT	4	
21	3GM-28356-A0	STAY 1	1	
22	90105-08652	BOLT, WASHER BASED	2	
23	4FM-26280-00	REAR VIEW MIRROR ASSY(LEFT)	1	UR WHITE
	4FM-26280-10	REAR VIEW MIRROR ASSY(LEFT)	1	UR BLACK
24	4FM-26290-00	REAR VIEW MIRROR ASSY(RIGHT)	1	UR WHITE

FIG. 39 COWLING 1

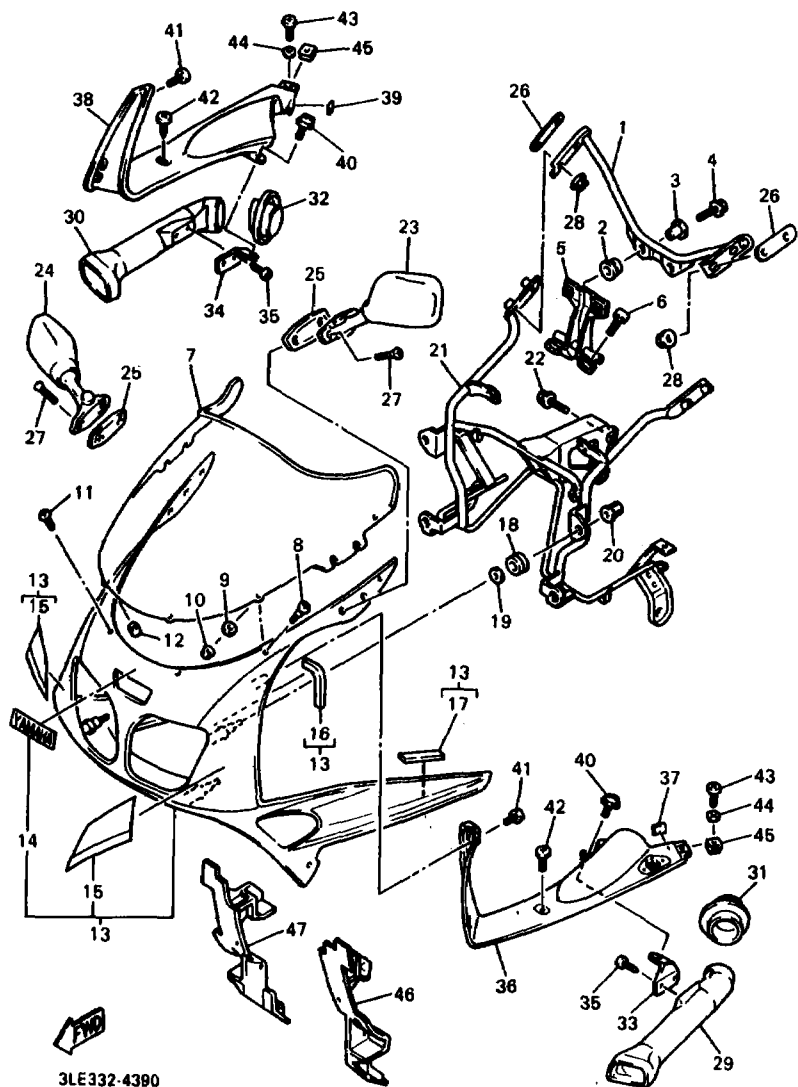

3LE332-4390

REF. NO.	PART NO.	DESCRIPTION	Q'TY	REMARKS
24	4FM-28290-10	REAR VIEW MIRROR ASSY(RIGHT)	1	UR BLACK
25	4FM-28299-00	PLATE, MIRROR FITTING 2	2	
26	3XV-28298-00	PLATE, MIRROR FITTING 1	2	
27	98706-06025	SCREW, FLAT HEAD	4	
28	95706-06500	NUT, FLANGE	4	
29	3GM-2838N-A0	DUCT 1	1	
30	3GM-2838R-A0	DUCT 2	1	
31	3GM-2838T-01	DUCT 3	1	
32	3GM-2838U-01	DUCT 4	1	
33	3GM-2836H-00	BRACKET 5	1	
34	3GM-2836J-00	BRACKET 6	1	
35	97706-40512	SCREW, TAPPING	4	
36	3GM-2836U-A0	PANEL 1	1	
37	34M-2139X-00	DAMPER	1	
38	3GM-2836V-A0	PANEL 2	1	
39	34M-2139X-00	DAMPER	1	
40	90159-06178	SCREW, WITH WASHER	2	
41	90167-05041	SCREW, TAPPING	2	
42	90154-05013	SCREW, BINDING	2	
43	90154-05059	SCREW, BINDING	2	
44	90202-05180	WASHER, PLATE	2	
45	90183-05024	NUT, SPRING	2	
46	3GM-28396-50	PLATE 1	1	
47	3GM-28397-50	PLATE 2	1	

FIG. 40 COWLING 2

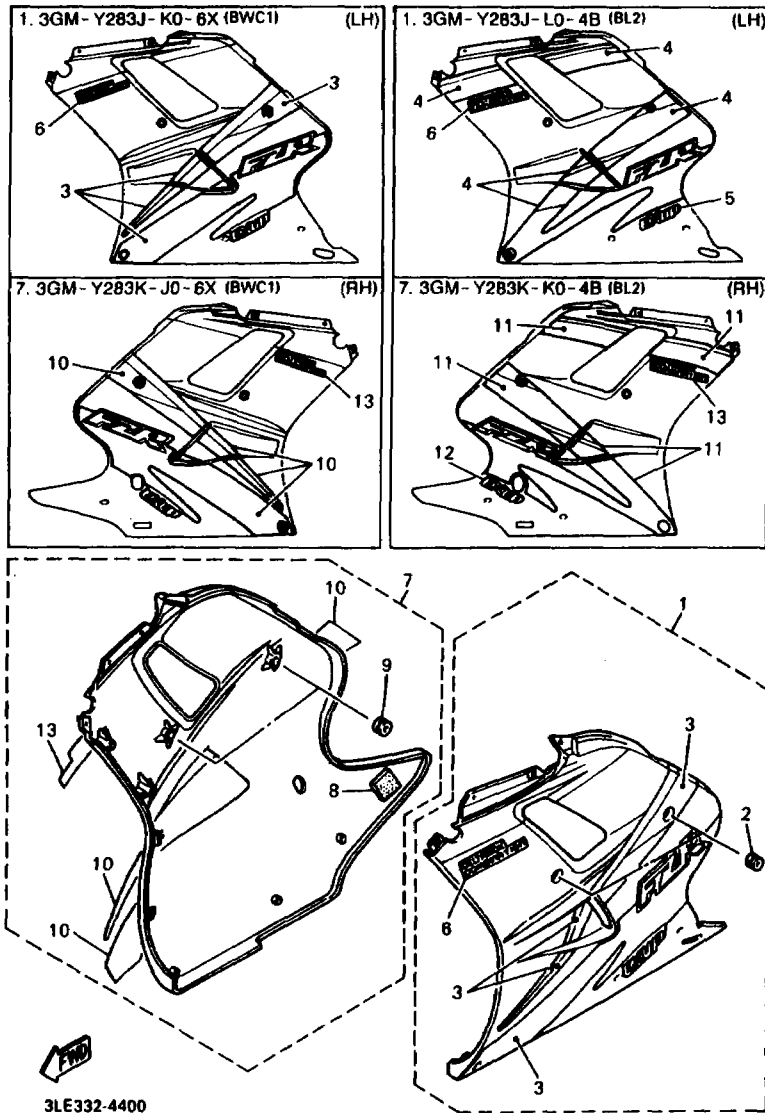

3LE332-4400

REF. NO.	PART NO.	DESCRIPTION	Q'TY	REMARKS
1	3GM-Y283J-K0-6X	BODY, FRONT LOWER 1	1	UR BILUSH WHITE COCKTAIL 1 /DULL GREENISH BLUE METALLIC 1
	3GM-Y283J-L0-4B	BODY, FRONT LOWER 1	1	UR BLACK 2
2	90480-13398	.GROMMET	2	
3	3LE-28301-01	.GRAPHIC SET, LOWER COVER 1	1	UR FOR BWC1
4	3LE-28301-11	.GRAPHIC SET, LOWER COVER 1	1	UR FOR BL2
5	3LE-28338-00	.EMBLEM	1	FOR BL2
6	3LE-28328-00	.EMBLEM	1	UR FOR BWC1
	3LE-28328-10	.EMBLEM	1	UR FOR BL2
7	3GM-Y283K-J0-6X	BODY, FRONT LOWER 2	1	UR BILUSH WHITE COCKTAIL 1/ DULL GREENISH BLUE METALLIC 1
	3GM-Y283K-K0-4B	BODY, FRONT LOWER 2	1	UR BLACK 2
8	30X-2139X-00	.DAMPER	1	
9	90480-13398	.GROMMET	2	
10	3LE-28303-01	.GRAPHIC SET, LOWER COVER 2	1	UR FOR BWC1
11	3LE-28303-11	.GRAPHIC SET, LOWER COVER 2	1	UR FOR BL2
12	3LE-28338-00	.EMBLEM	1	FOR BL2
13	3LE-28328-00	.EMBLEM	1	UR FOR BWC1
	3LE-28328-10	.EMBLEM	1	UR FOR BL2

FIG. 41 COWLING 3

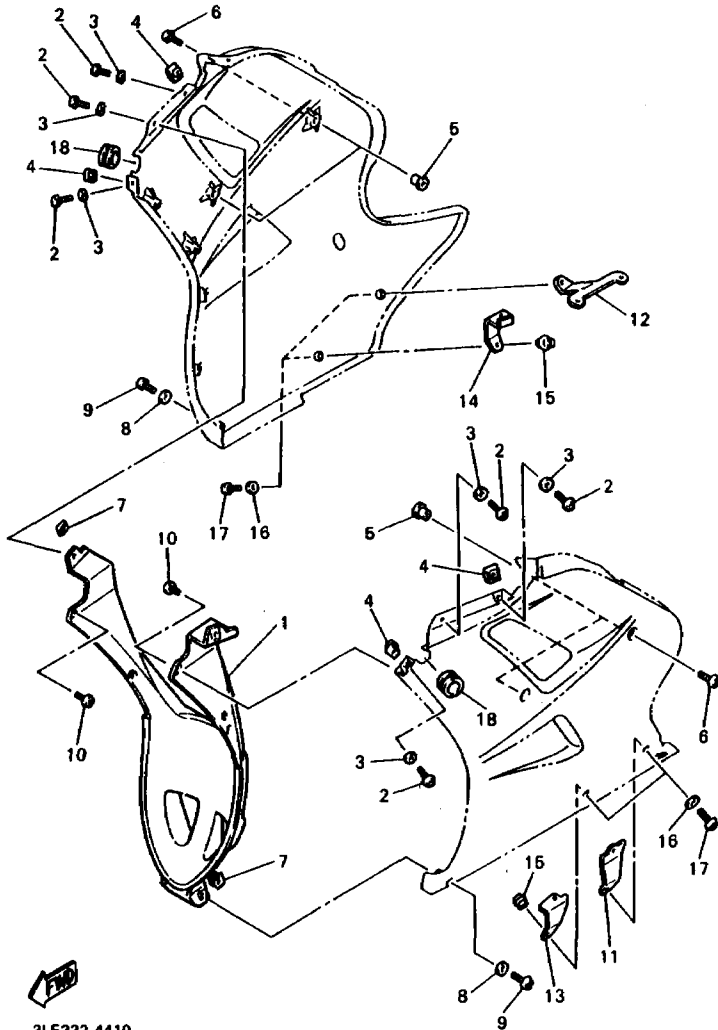

3LE332-4410

REF. NO.	PART NO.	DESCRIPTION	Q'TY	REMARKS
1	3GM-2836K-50-P0	PANEL, INNER 1	1	UR DULL GREENISH BLUE METALLIC UR BLACK 2
	3GM-2836K-50-4B	PANEL, INNER 1	1	
2	90154-05059	SCREW, BINDING	6	
3	90202-05180	WASHER, PLATE	6	
4	90183-05024	NUT, SPRING	4	
5	90387-067N6	COLLAR	4	
6	90154-08061	SCREW, BINDING	4	
7	90183-05024	NUT, SPRING	4	
8	90202-05180	WASHER, PLATE	2	
9	90154-05059	SCREW, BINDING	2	
10	90167-05041	SCREW, TAPPING	4	
11	3GM-2836A-00	BRACKET 1	1	
12	3GM-2836E-50	BRACKET 2	1	
13	3GM-2836F-00	BRACKET 3	1	
14	3GM-2836G-00	BRACKET 4	1	
16	90179-05523	NUT	4	
16	90202-05180	WASHER, PLATE	4	
17	90154-05059	SCREW, BINDING	4	
18	90480-35528	GROMMET	2	

FIG. 42 GENERATOR

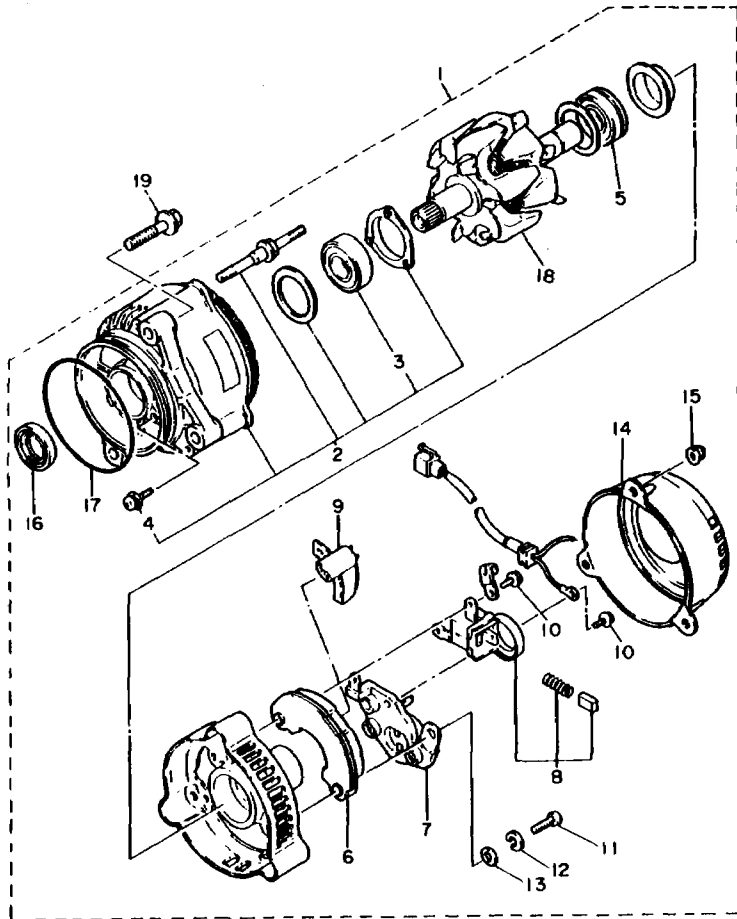

REF. NO.	PART NO.	DESCRIPTION	Q'TY	REMARKS
1	2GH-81600-55	A.C. GENERATOR ASSY	1	
2	3FV-81634-00	.STATOR ASSY	1	
3	36Y-81643-30	..BEARING	1	
4	2KT-81645-50	..SCREW	3	
5	36Y-81643-50	.BEARING	1	
6	4BH-81970-00	.RECTIFIER ASSY	1	
7	36Y-81910-50	.VOLTAGE REGULATOR ASSY	1	
8	3FV-81619-00	.BRUSH HOLDER ASSY	1	
9	36Y-81972-50	.COVER, RECTIFIER	1	
10	3FV-81645-00	.SCREW	2	
11	98580-05018	.SCREW, PAN HEAD	3	
12	92901-05100	.WASHER, SPRING	3	
13	92901-05600	.WASHER, PLATE	3	
14	3FV-81604-00	.COVER ASSY	1	
15	3FV-81675-00	.NUT	3	
16	36Y-81638-50	.OIL SEAL	1	
17	2KT-81642-50	.O-RING	1	
18	2GH-81880-52	.ROTOR ASSY	1	
19	95818-08030	BOLT, FLANGE	3	

3LE332-9400

FIG. 43 PICK UP COIL • GOVERNOR

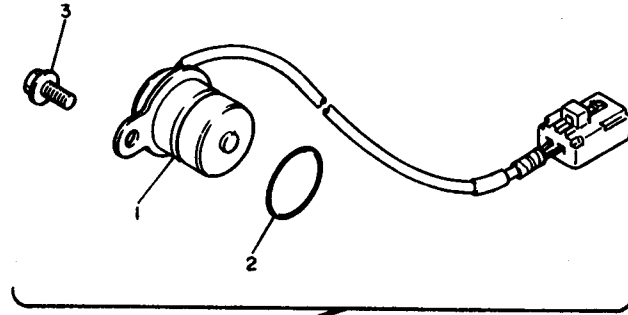

REF. NO.	PART NO.	DESCRIPTION	Q'TY	REMARKS
1	3GM-81670-00	PICK-UP ASSY	1	
2	93210-19216	O-RING	1	
3	95023-06012	BOLT	1	

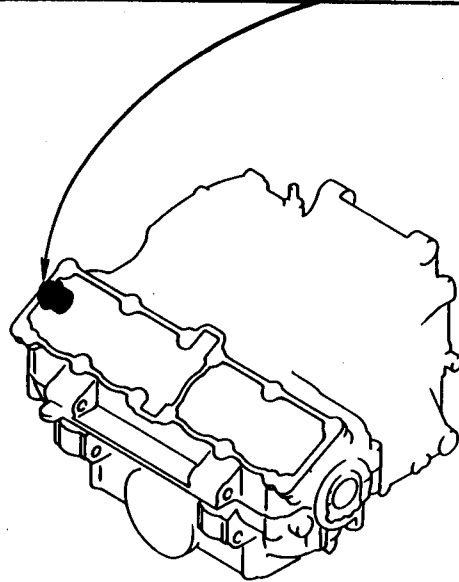

2GH300-7400

FIG. 44 STARTING MOTOR

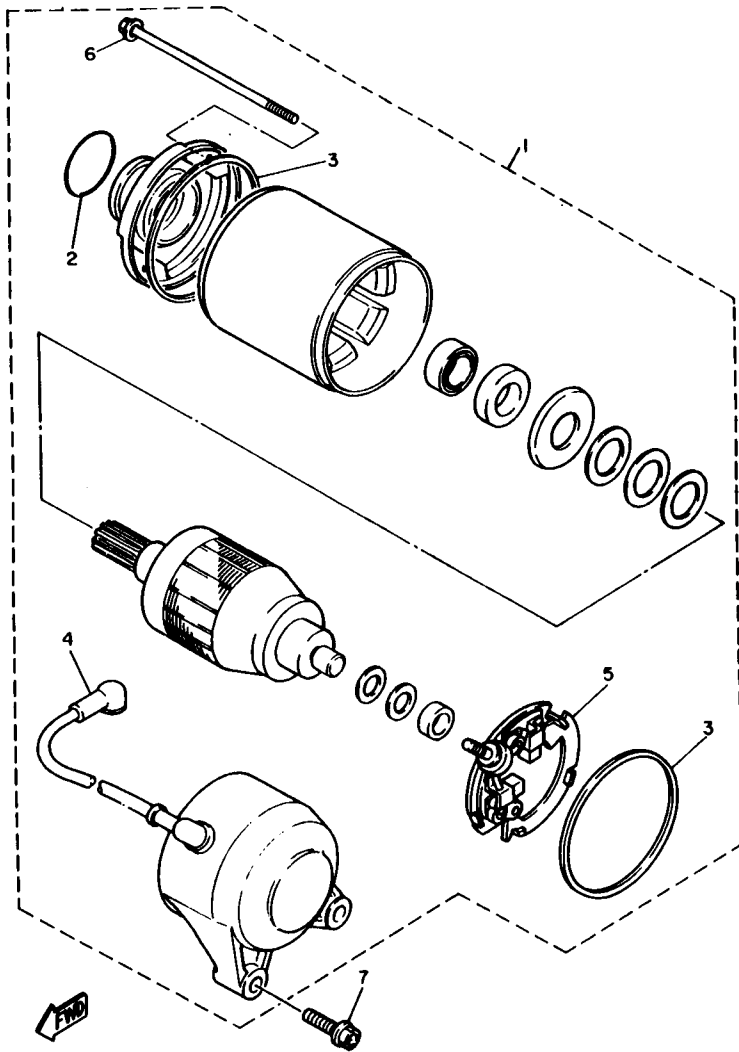

REF. NO.	PART NO.	DESCRIPTION	QTY	REMARKS
1	3GM-81800-50	STARTING MOTOR ASSY	1	
2	26H-81847-00	.O-RING	1	
3	11H-81844-00	.GASKET	2	
4	3GM-81815-50	.CORD, STARTER MOTOR	1	
5	3KS-81840-00	.BRUSH HOLDER ASSY	1	
6	3HE-81826-00	.BOLT	2	
7	95B11-06025	BOLT, FLANGE	2	

3KS351-8420

F6

FIG. 45 FLASHER LIGHT

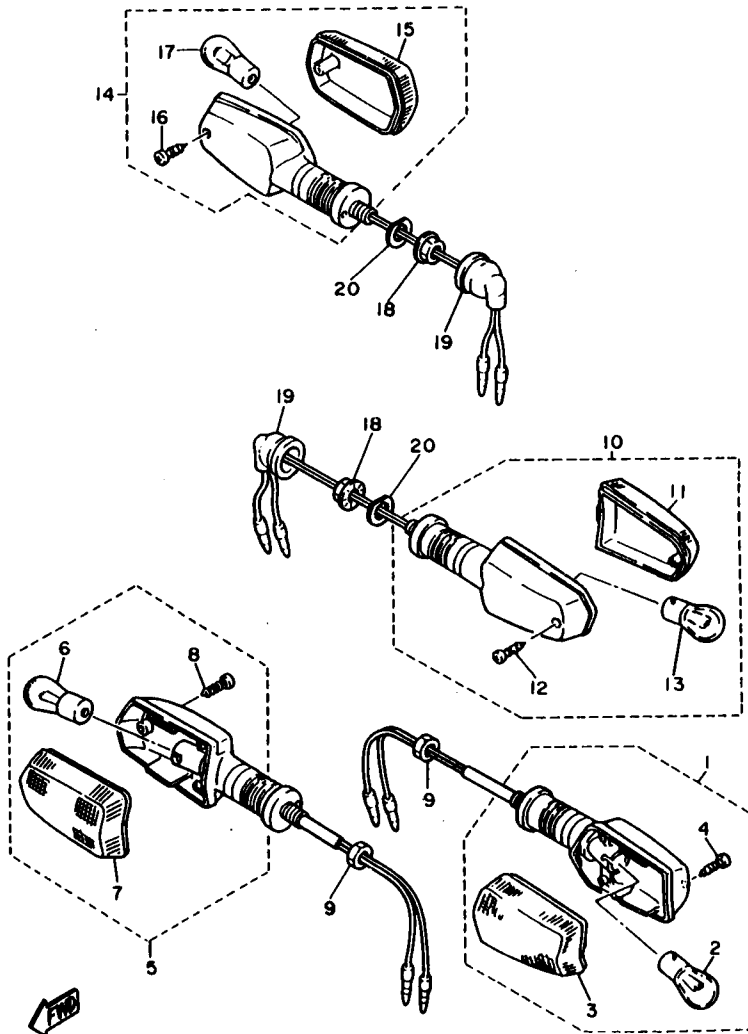

3LE332-1450

REF. NO.	PART NO.	DESCRIPTION	Q'TY	REMARKS
1	3GM-83310-00	FRONT FLASHER LIGHT ASSY 1	1	
2	306-83311-40	.BULB, FLASHER (12V-21W)	1	
3	51L-83332-01	.LENS, FLASHER	1	
4	97706-40620	.SCREW, TAPPING	1	
5	3GM-83320-00	FRONT FLASHER LIGHT ASSY 2	1	
6	306-83311-40	.BULB, FLASHER (12V-21W)	1	
7	51L-83342-01	.LENS, FLASHER 2	1	
8	87706-40620	.SCREW, TAPPING	1	
9	95306-12600	NUT	2	
10	51J-83330-00	REAR FLASHER LIGHT ASSY 1	1	
11	1VU-83332-00	.LENS, FLASHER	1	
12	97706-40620	.SCREW, TAPPING	1	
13	306-83311-40	.BULB, FLASHER (12V-21W)	1	
14	51J-83340-00	FLASHER LIGHT ASSY 2	1	
15	1VU-83342-00	.LENS, FLASHER 2	1	
16	97706-40620	.SCREW, TAPPING	1	
17	306-83311-40	.BULB, FLASHER (12V-21W)	1	
18	95706-12500	NUT, FLANGE	2	
19	18G-83365-00	CAP	2	
20	90214-12033	WASHER, CLAW	2	

FIG. 46 METER

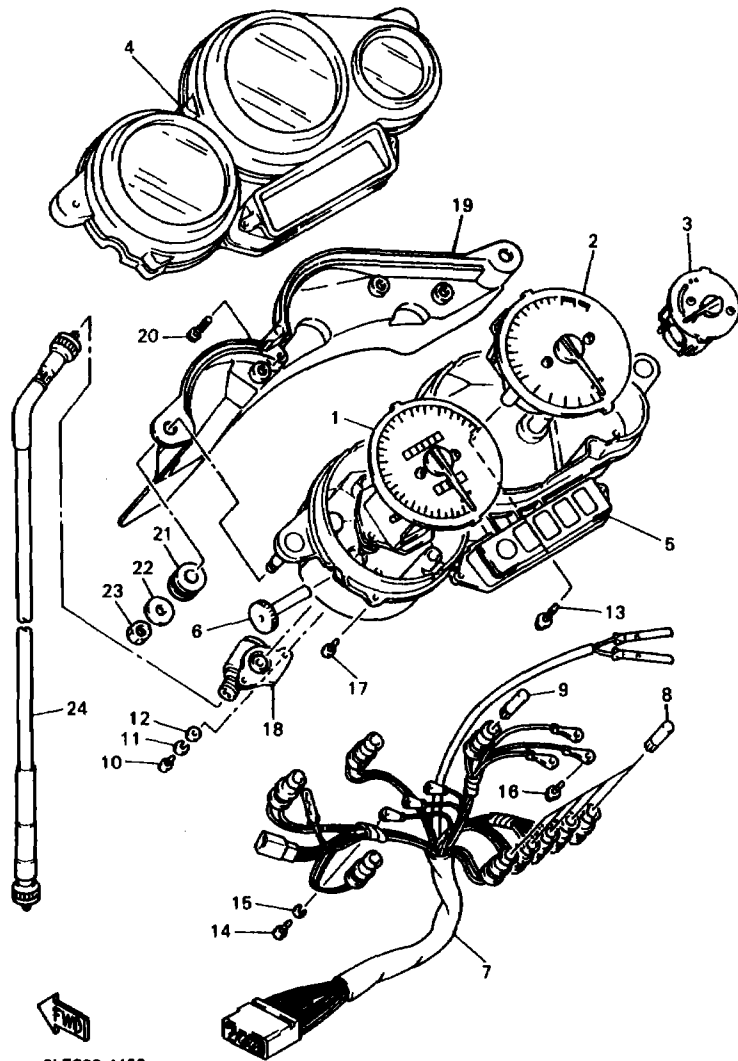

REF. NO.	PART NO.	DESCRIPTION	Q'TY	REMARKS
1	4FM-83670-00	SPEEDOMETER ASSY	1	
2	3GM-83540-20	TACHOMETER ASSY	1	
3	4FM-83590-00	WATER TEMPERATURE ASSY	1	
4	4FM-83559-00	COVER, METER	1	
5	4FM-8353H-40	CASE, UNDER	1	
6	2GH-83578-00	KNOB, TRIP METER	1	
7	3GM-83509-10	SOCKET CORD ASSY	1	
8	4G1-84744-00	BULB (12V-3.4W)	5	
9	2GV-83517-00	BULB, (12V-1.7W, T8.5)	4	
10	98580-04010	SCREW, PAN HEAD	4	
11	92990-04100	WASHER, SPRING	4	
12	92901-04600	WASHER, PLATE	4	
13	97902-04122	SCREW, WITH WASHER	2	
14	98580-03010	SCREW, PAN HEAD	3	
15	92990-03100	WASHER, SPRING	3	
16	90159-03102	SCREW, WITH WASHER	3	
17	90184-04023	SCREW, TAPPING	5	
18	4FM-83520-00	SOCKET CORD ASSY	1	
19	3GM-87278-A0	COVER, METER	1	
20	97706-40012	SCREW, TAPPING	1	
21	90480-14595	GROMMET	2	
22	90201-08059	WASHER, PLATE	2	
23	95318-08800	NUT	2	
24	4FM-83550-00	SPEEDOMETER CABLE ASSY	1	

FIG. 47 HEADLIGHT

REF. NO.	PART NO.	DESCRIPTION	Q'TY	REMARKS
1	4FM-84330-41	BODY ASSY	1	
2	4FM-84320-10	LENS ASSY	1	
3	4FM-8432A-10	LENS ASSY	1	
4	2F9-84314-00	BULB (12V-60/65W)	2	(H4)HALOGEN
5	4JG-84397-00	COVER, SOCKET	2	
6	51L-84334-00	NUT, ADJUSTING	4	
7	90338-24112	PLUG	1	
8	3GM-84301-00	PILOT LIGHT ASSY 1	1	
9	3GM-84321-00	.LENS ASSY	1	
10	3GM-84322-00	.GASKET, LENS	1	
11	2JE-84744-00	.BULB (12V 5W)	1	
12	3GM-84192-00	.SCREW(M4,L=12)	2	
13	3GM-84367-50	DAMPER, HEADLIGHT 2	1	
14	90167-05041	SCREW, TAPPING	2	
15	3GM-8431R-00	STAY, SETTING	1	
16	90480-10517	GROMMET	2	
17	90387-052U6	COLLAR	2	
18	90167-05037	SCREW, TAPPING	2	
19	3GM-84359-50	CORD, HEADLIGHT	1	

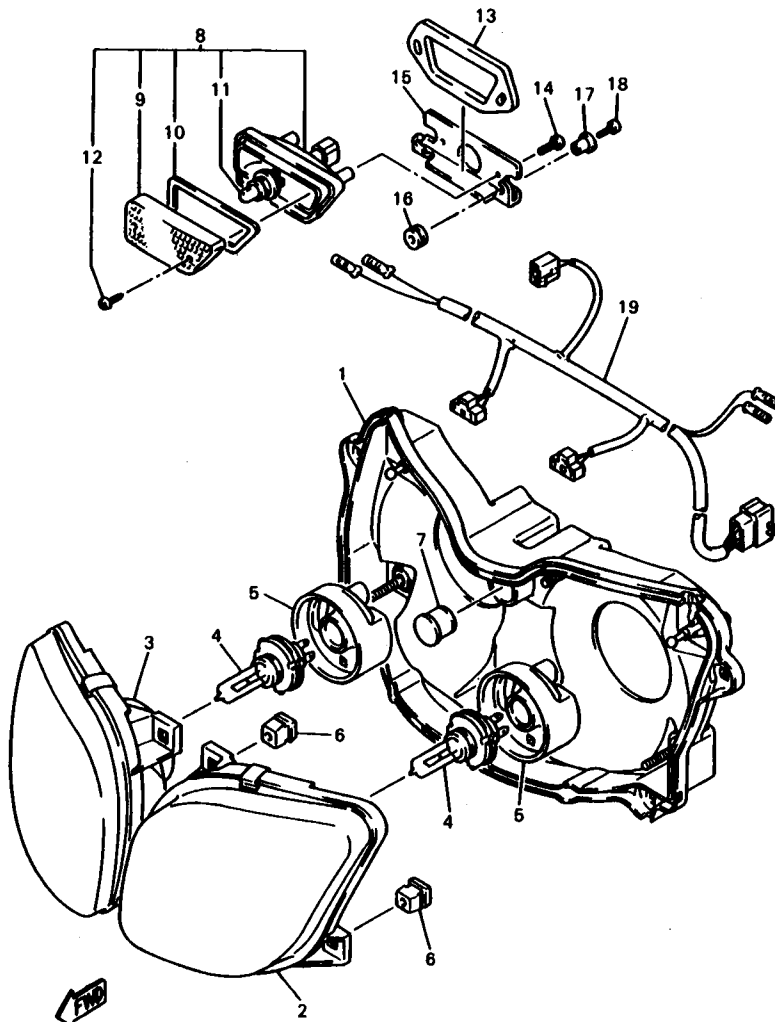

3LE332-4470

FIG. 48 TAILLIGHT

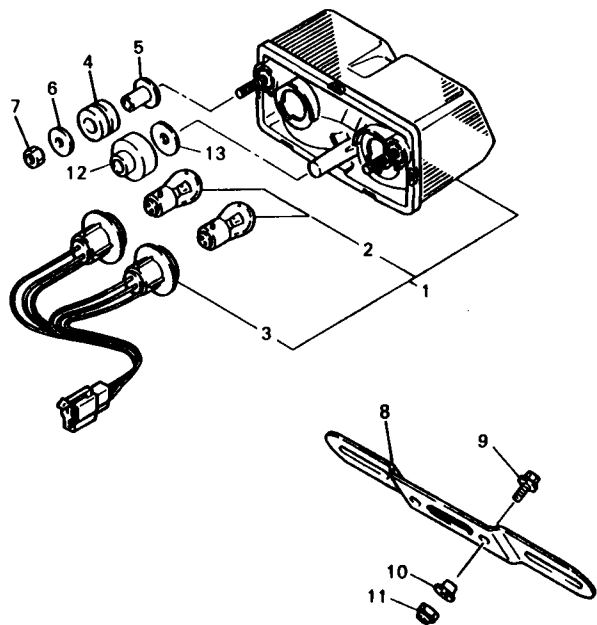

REF. NO.	PART NO.	DESCRIPTION	Q'TY	REMARKS
1	3GM-84710-20	TAILLIGHT UNIT ASSY	1	
2	31L-84714-00	BULB, TAILLIGHT (12V-21/5W)	2	
3	3LK-8473A-00	CORD ASSY	1	
4	90480-18276	GROMMET	2	
5	90387-062W4	COLLAR	2	
6	90201-063J2	WASHER, PLATE	2	
7	95380-06600	NUT	2	
8	3YF-84751-00	BRACKET, LICENSE	1	
9	95026-06016	BOLT, FLANGE	2	
10	90387-061M0	COLLAR	2	
11	95616-06100	NUT, U	2	
12	90480-15259	GROMMET	1	
13	90201-105J4	WASHER, PLATE	1	



3LE332-4480

FIG. 49 ELECTRICAL 1

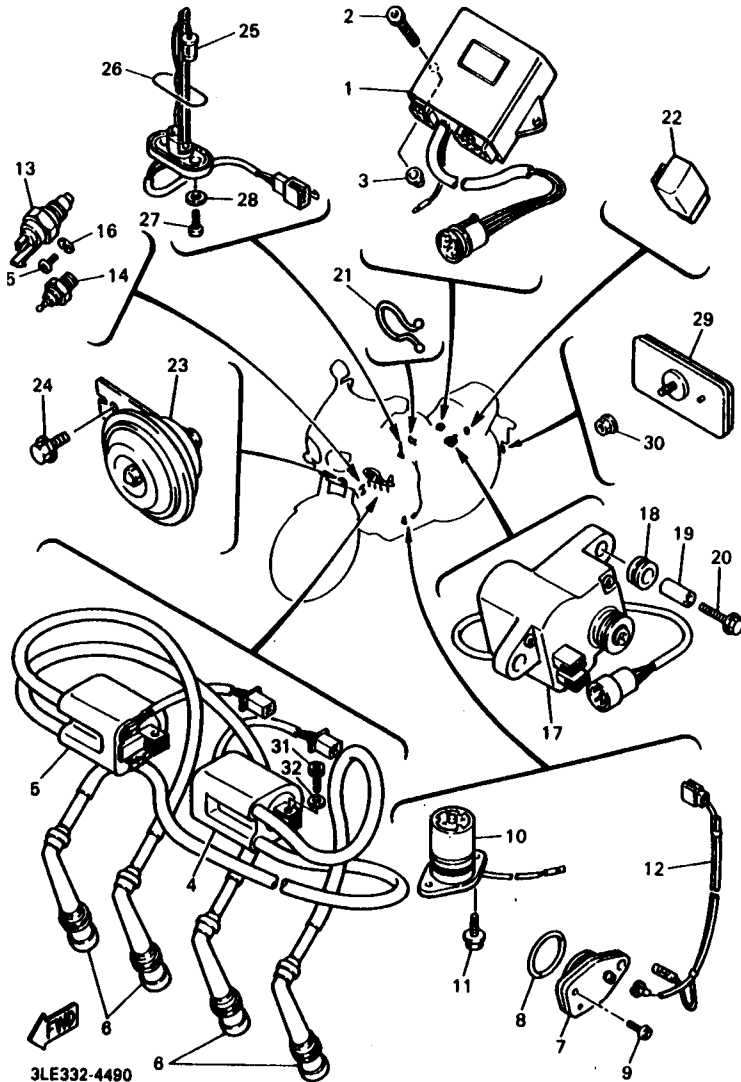

REF. NO.	PART NO.	DESCRIPTION	Q'TY	REMARKS
1	3GM-82305-10	IGNITOR UNIT ASSY	1	
2	90110-06158	BOLT, HEXAGON SOCKET HEAD	1	
3	31A-14477-00	PLATE	1	
4	3GM-82310-00	IGNITION COIL ASSY	1	
5	3GM-82320-00	IGNITION COIL ASSY	1	
6	2KT-82370-00	PLUG CAP ASSY	4	
7	1AE-82640-00	NEUTRAL SWITCH ASSY	1	
8	93210-29196	O-RING	1	
9	98580-08016	SCREW, PAN HEAD	2	
10	3GM-85720-00	OIL LEVEL GAUGE ASSY	1	
11	95026-06016	BOLT, FLANGE	2	
12	4FM-82541-00	WIRE, LEAD	1	
13	2EL-82660-00	THERMO SWITCH ASSY	1	
14	11H-83591-00	THERMO UNIT	1	
15	98501-05008	SCREW, PAN HEAD	1	
16	92901-05100	WASHER, SPRING	1	
17	3GM-85820-00	SERVO MOTOR ASSY	1	
18	90480-14412	GROMMET	2	
19	90387-085V1	COLLAR	2	
20	95811-06035	BOLT, FLANGE	2	
21	90484-30040	CLAMP	1	
22	3GM-83350-00	FLASHER RELAY ASSY	1	
23	3HE-83371-00	HORN	1	
24	95811-06010	BOLT, FLANGE	1	
25	3GM-85752-01	SENDER UNIT ASSY, FUEL METER	1	
26	42X-85753-00	GASKET, SENDER UNIT	1	
27	90149-08011	SCREW	2	
28	90202-05187	WASHER, PLATE	2	

FIG. 49 ELECTRICAL 1

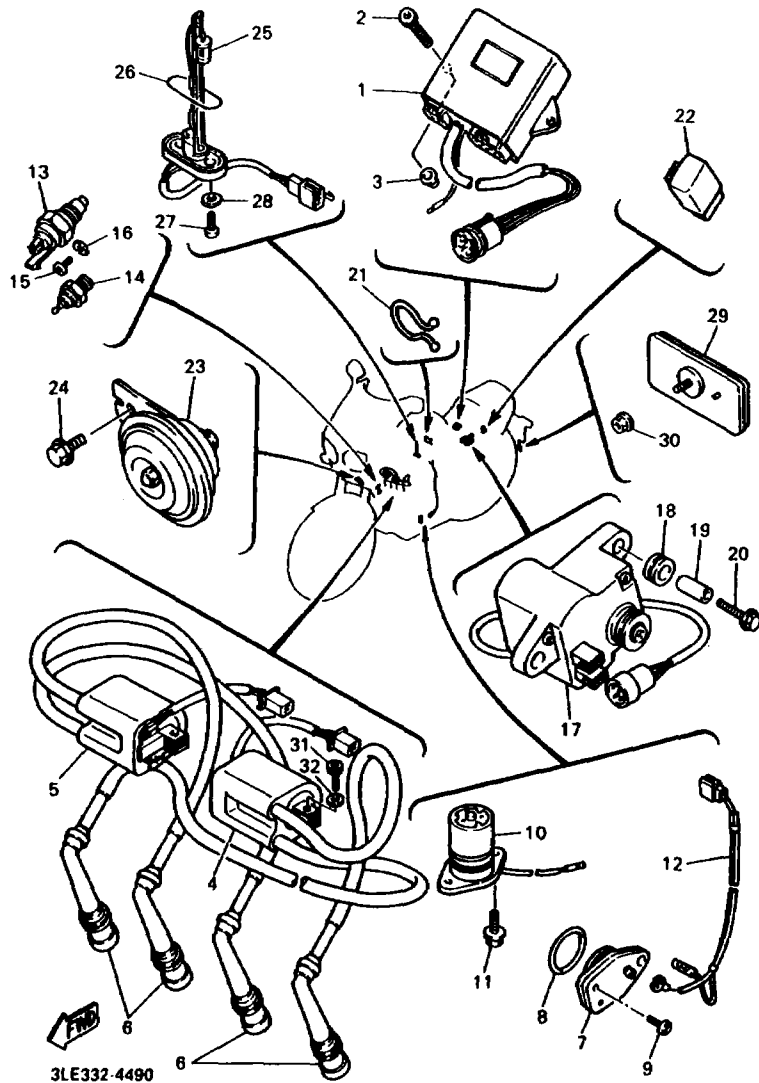

REF. NO.	PART NO.	DESCRIPTION	QTY	REMARKS
29	3G1-85130-01	REAR REFLECTOR ASSY	1	UR
	4CF-85130-00	REAR REFLECTOR ASSY	1	UR FOR OCEANIA
30	95701-05500	NUT, FLANGE	1	
31	97011-08020	BOLT	4	
32	92990-06600	WASHER, PLATE	4	

FIG. 50 ELECTRICAL 2

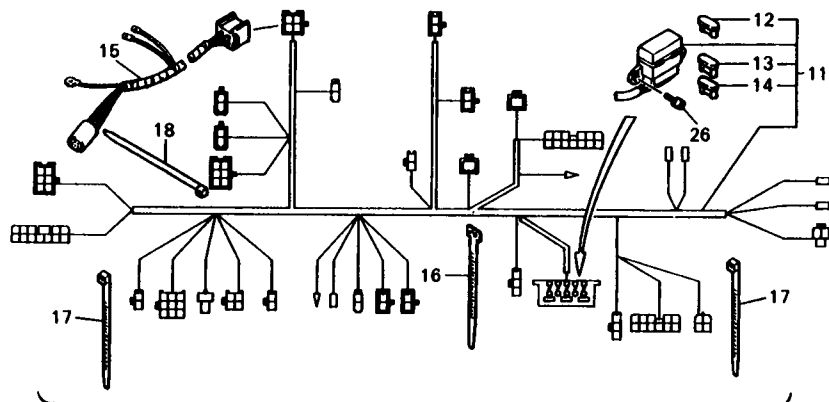

REF. NO.	PART NO.	DESCRIPTION	Q'TY	REMARKS
1	36Y-81940-00	STARTER RELAY ASSY	1	
2	95701-06500	NUT, FLANGE	2	
3	3XW-82100-00	BATTERY ASSY (YTX14-BS)	1	
4	5Y1-82122-00	SEAT, BATTERY	1	
5	2T4-82131-00	BAND, BATTERY	1	
6	3GM-82115-50	WIRE, PLUS LEAD	1	
7	3XW-82116-00	WIRE, MINUS LEAD	1	
8	4JH-82501-00	MAIN SWITCH STEERING LOCK	1	UR
	4NA-82501-00	MAIN SWITCH STEERING LOCK	1	UR FOR OCEANIA
9	90109-080G5	BOLT	2	
10	3GM-82530-11	STOP SWITCH ASSY	1	
11	3GM-82590-30	WIRE HARNESS ASSY	1	UR
	3LK-82590-20	WIRE HARNESS ASSY	1	UR FOR OCEANIA
12	1AE-82151-00	.FUSE (30A-BL)	2	
13	42X-82151-00	.FUSE (10A-BL)	4	
14	2GH-82151-00	.FUSE (20A-BL)	2	
15	3GM-82509-00	WIRE, SUB LEAD	1	
16	90464-13080	CLAMP	2	
17	90464-13073	CLAMP	7	
18	25G-83936-01	BAND, SWITCH CORD	2	
19	3EN-81950-00	RELAY ASSY	1	
20	4BH-8195A-00	RELAY ASSY	1	
21	98780-05018	SCREW, FLAT HEAD	2	
22	95701-05500	NUT, FLANGE	2	
23	3TJ-83984-00	SWITCH	1	
24	2KT-82566-01	SWITCH, SIDE STAND	1	
25	90152-05021	SCREW, COUNTERSUNK	2	
26	90159-06033	SCREW, WITH WASHER	2	

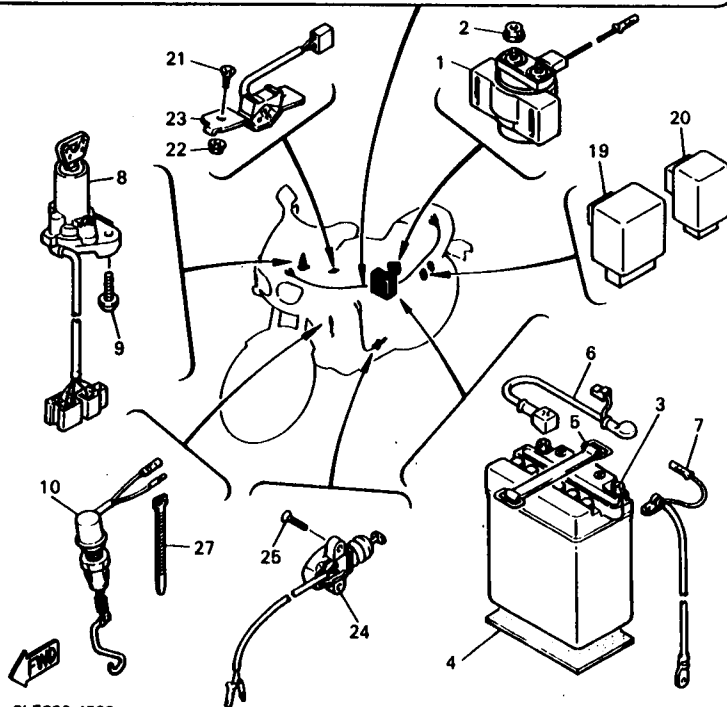

3LE332-4500

FIG. 50 ELECTRICAL 2

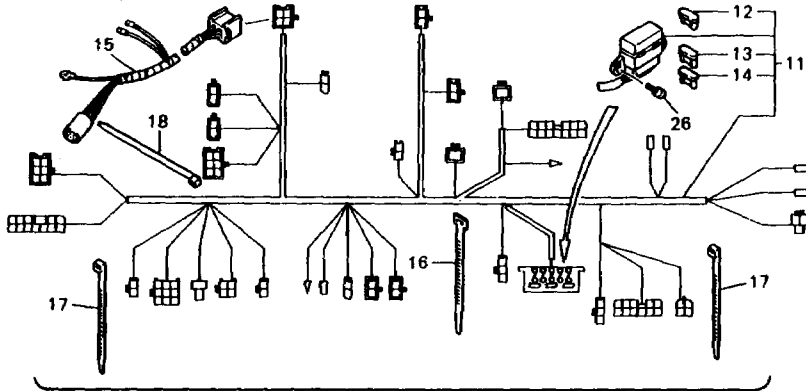

REF. NO.	PART NO.	DESCRIPTION	Q'TY	REMARKS
27	5Y9-12491-00	CLAMP 1	1	

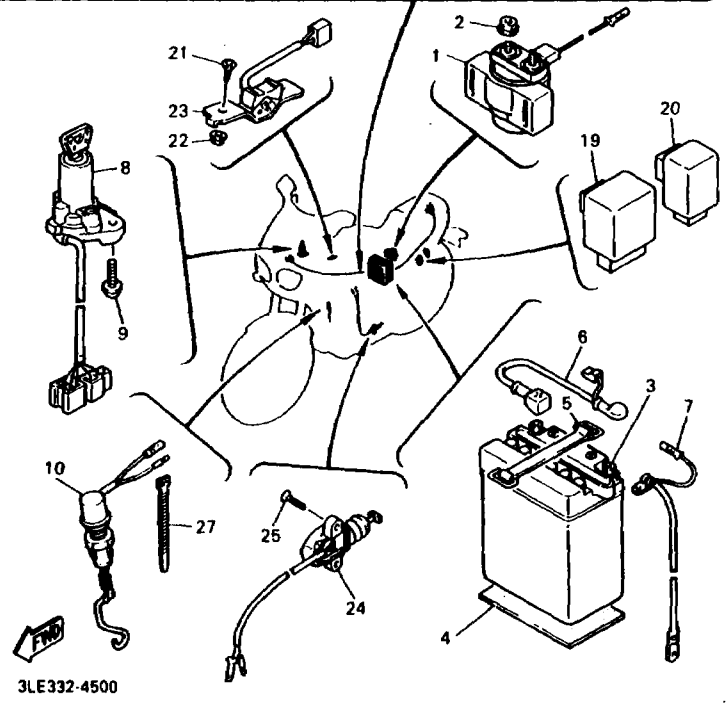

3LE332-4500

INDIVIDUAL SPEC.

FOR FINLAND SWEDEN

The following pages provides a listing of only the parts that meet the specifications peculiar to your market. For those parts not appearing in these pages, refer to the "GENERAL SPEC" section.

FIG. 51 ALTERNATE (CARBURETOR)

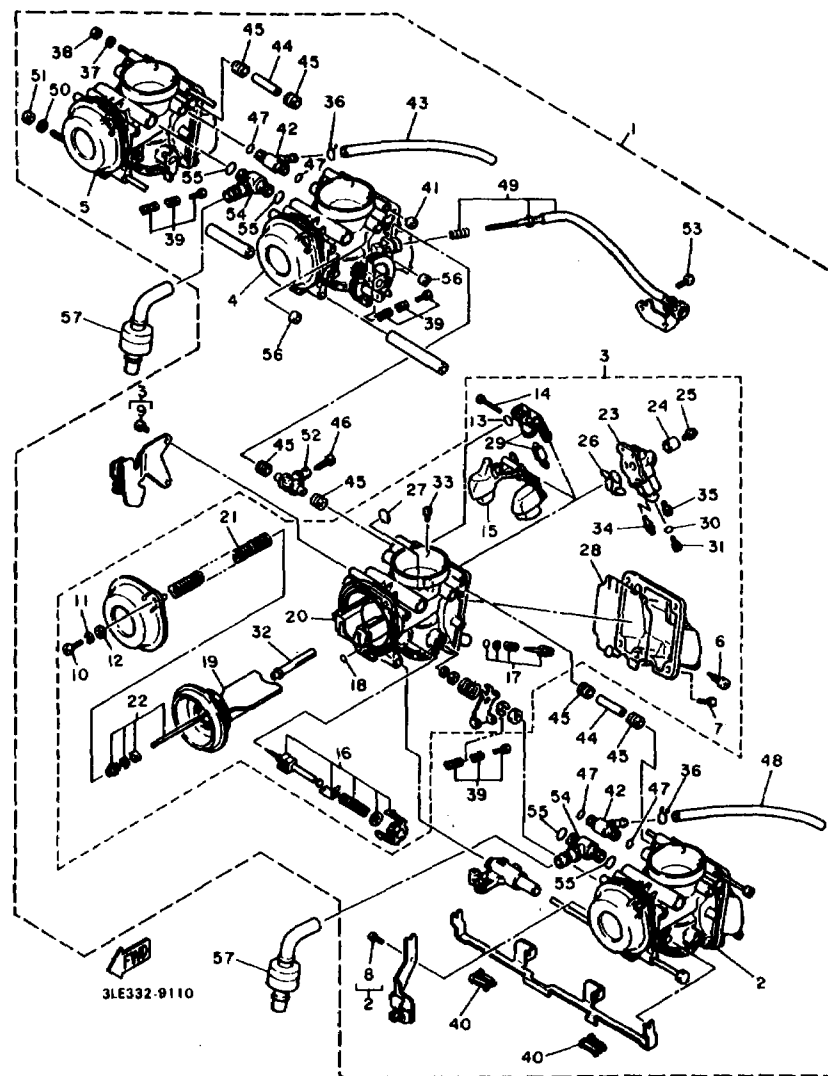

REF. NO.	PART NO.	DESCRIPTION	Q'TY	REMARKS
1	3LF-14900-00	CARBURETOR ASSY	1	
2	3LF-14901-00	..CARBURETOR ASSY 1	1	
3	3LF-14902-00	..CARBURETOR ASSY 2	1	
4	3LF-14903-00	..CARBURETOR ASSY 3	1	
5	3LF-14904-00	..CARBURETOR ASSY 4	1	
6	12R-14191-00	..PLUG, DRAIN	1	
7	98501-05012	..SCREW, PAN HEAD	4	
8	98580-04008	..SCREW, PAN HEAD	1	
9	98580-04008	..SCREW, PAN HEAD	2	
10	98586-05016	..SCREW, PAN HEAD	2	
11	92906-05100	..WASHER, SPRING	2	
12	92906-05600	..WASHER, PLATE	2	
13	3EN-14147-00	..O-RING	1	
14	63L-14186-00	..PIN, FLOAT	1	
15	3GM-14985-00	..FLOAT	1	
16	3EN-1410A-00	..STARTER SET	1	
17	12R-14105-00	..PILOT SCREW SET	1	
18	3FV-14147-00	..O-RING	1	
19	3GM-14940-00	..DIAPHRAGM ASSY	1	
20	3GM-1411E-00	..BLOCK, JET	1	
21	3FV-14933-00	..SPRING, DIAPHRAGM	1	
22	3GM-1490J-00	..NEEDLE SET	1	
23	3GM-1411A-00	..BLOCK JET ASSY	1	
24	3GM-14153-00	..WASHER, MAIN JET	1	
26	1HX-14565-00	..SCREW	1	
28	3LF-14147-00	..O-RING	1	
27	1AE-14147-00	..O-RING	1	
28	3GM-14997-00	..SEAL	1	

FIG. 51 ALTERNATE (CARBURETOR)

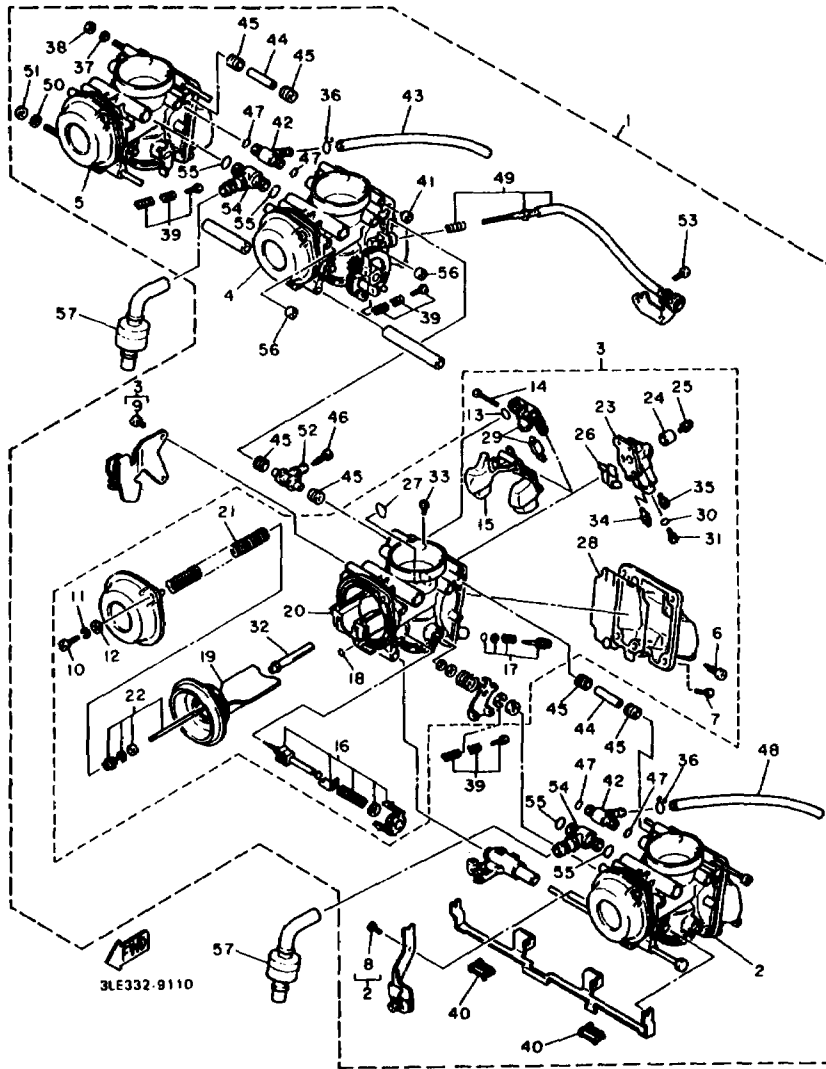

REF. NO.	PART NO.	DESCRIPTION	Q'TY	REMARKS
29	3GM-14107-17	..NEEDLE VALVE SET	1	
30	1AE-14227-00	..O-RING	1	
31	3G2-1423A-76	..JET, MAIN (#127.5)	1	UR
	3G2-14231-25	..JET, MAIN (#125)	1	UR
32	3GM-14141-90	..NOZZLE, MAIN	1	
33	830-14231-23	..JET, MAIN (#115)	1	
34	4G0-14142-40	..JET, PILOT (# 40)	1	
35	3G2-14231-12	..JET, POWER (# 60)	1	
36	8U9-14139-00	..CLIP, PIPE	2	
37	92901-05600	..WASHER, PLATE	1	
38	95380-05600	..NUT	1	
39	3EN-1490K-00	..STOP SCREW SET	3	
40	3EN-14261-00	..HOLDER	2	
41	3GM-14918-00	..RING	1	
42	17A-14251-00	..NIPPLE	2	
43	2GH-14197-00	..PIPE	1	
44	3GM-14988-00	..PIPE, STARTER CONNECTING	2	
45	3EN-14997-00	..SEAL	8	
46	1KT-14994-00	..NET, FILTER	1	
47	822-14147-00	..O-RING	4	
48	3LF-14197-00	..PIPE	1	
49	3GM-14103-00	..THROTTLE SCREW SET	1	
50	92990-06800	..WASHER, PLATE	1	
51	95380-06800	..NUT	1	
52	3EN-14988-00	..PIPE, STARTER CONNECTING	1	
53	98501-05008	..SCREW, PAN HEAD	1	
54	3GM-14251-00	..NIPPLE	2	
55	3LK-14147-00	..O-RING	4	

FIG. 51 ALTERNATE (CARBURETOR)

REF. NO.	PART NO.	DESCRIPTION	Q'TY	REMARKS
56	3GM-14992-00	.ROD	2	
57	3GM-14197-00	PIPE	2	

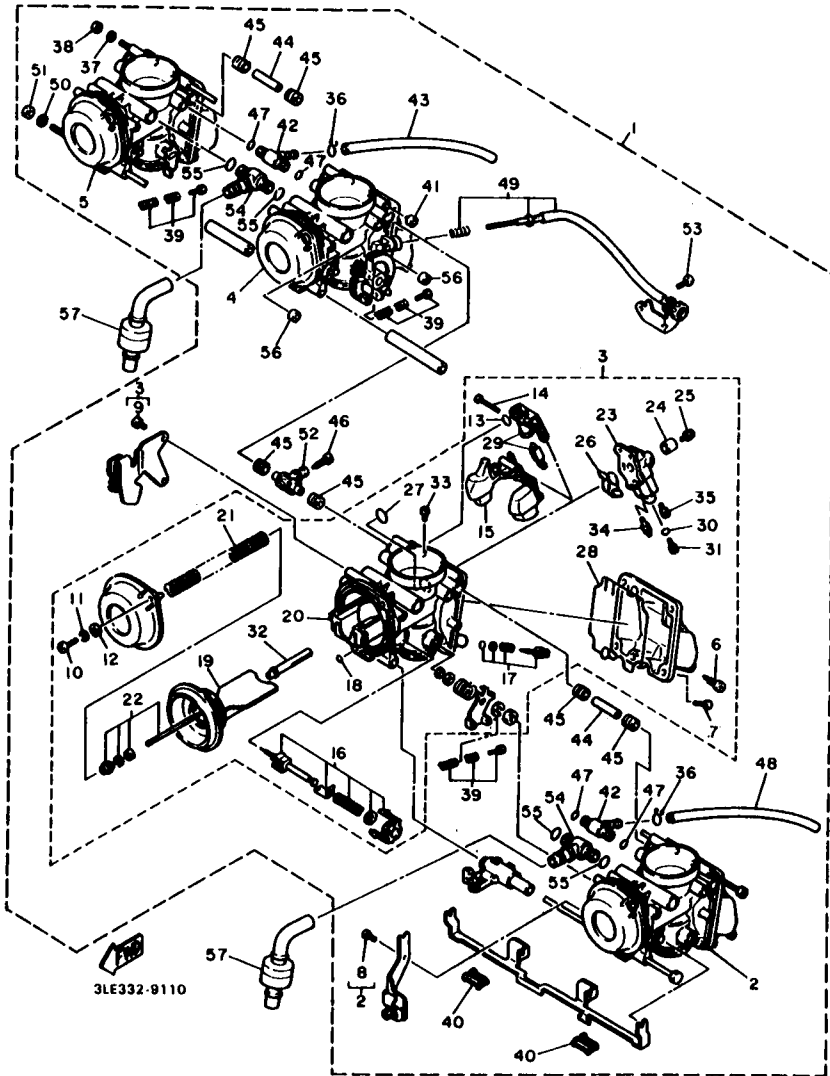
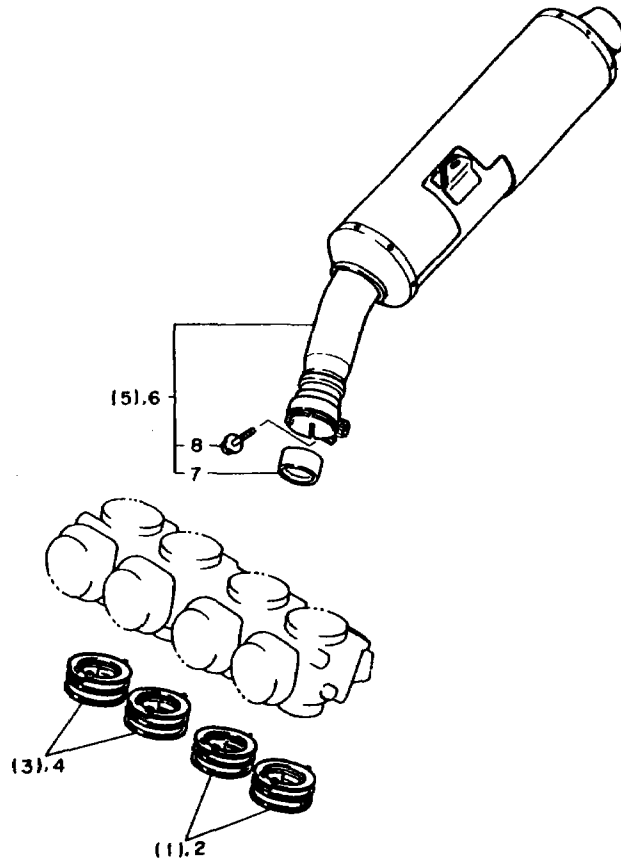

FIG. 52 ALTERNATE (ENGINE)



REF. NO.	PART NO.	DESCRIPTION	Q'TY	REMARKS
1	3GM-13597-00	JOINT, CARBURETOR 3	*	
2	3LF-13597-00	JOINT, CARBURETOR 3	2	
3	3GM-13598-00	JOINT, CARBURETOR 4	*	
4	3LF-13598,00	JOINT, CARBURETOR 4	2	
5	3GM-14710-51	MUFFLER ASSY 1	*	
6	3LE-14710-30	MUFFLER ASSY 1	1	
7	3HE-14755-00	.GASKET, SILENCER	1	
8	95816-08025	.BOLT, FLANGE	1	

* For Convenience of reference:
Disregard the items asterisked (*) in the "QTY" column. These are intended for GENERAL SPEC, and NOT for INDIVIDUAL SPEC.



3GM300-9560

FIG. 53 ALTERNATE (ELECTRICAL)

REF. NO.	PART NO.	DESCRIPTION	Q'TY	REMARKS
1	3GM-82305-10	IGNITOR UNIT ASSY	*	
2	3LF-82305-10	IGNITOR UNIT ASSY	1	

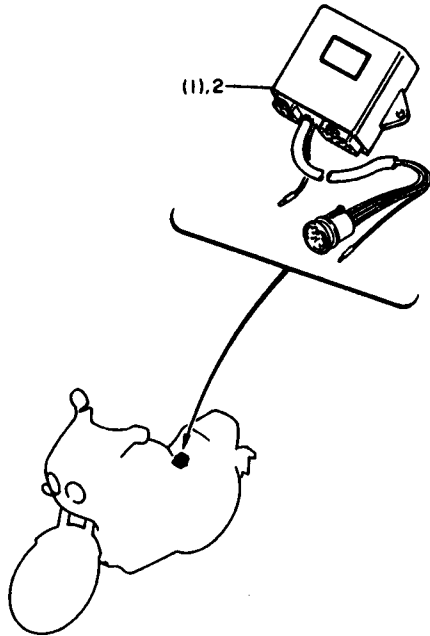

3GM300-1640

* For Convenience of reference:
Disregard the items asterisked (*) in the "QTY" column. These are intended for
GENERAL SPEC, and NOT for INDIVIDUAL SPEC.

FOR AUSTRIA

The following pages provides a listing of only the parts that meet the specifications peculiar to your market. For those parts not appearing in these pages, refer to the "GENERAL SPEC" section.

FIG. 54 ALTERNATE (CARBURETOR)

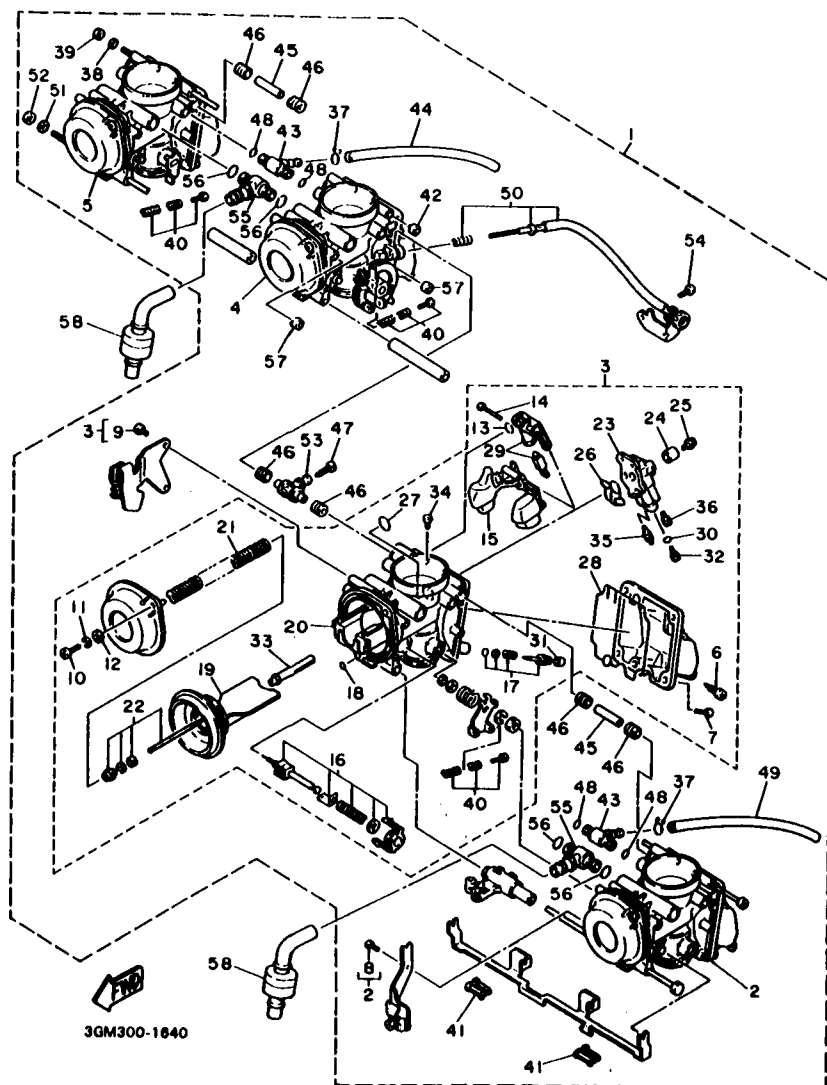

REF. NO.	PART NO.	DESCRIPTION	Q'TY	REMARKS
1	3LH-14900-01	CARBURETOR ASSY	1	
2	3LH-14901-01	..CARBURETOR ASSY 1	1	
3	3LH-14902-01	..CARBURETOR ASSY 2	1	
4	3LH-14903-01	..CARBURETOR ASSY 3	1	
5	3LH-14904-01	..CARBURETOR ASSY 4	1	
6	12R-14191-00	..PLUG, DRAIN	1	
7	98501-05012	..SCREW, PAN HEAD	4	
8	98580-04008	..SCREW, PAN HEAD	1	
9	98580-04008	..SCREW, PAN HEAD	2	
10	98586-05016	..SCREW, PAN HEAD	2	
11	92906-05100	..WASHER, SPRING	2	
12	92906-05800	..WASHER, PLATE	2	
13	3EN-14147-00	..O-RING	1	
14	53L-14186-00	..PIN, FLOAT	1	
15	3GM-14985-00	..FLOAT	1	
16	3EN-1410A-00	..STARTER SET	1	
17	12R-14105-00	..PILOT SCREW SET	1	
18	3FV-14147-00	..O-RING	1	
19	3GM-14940-00	..DIAPHRAGM ASSY	1	
20	3GM-1411E-00	..BLOCK, JET	1	
21	3FV-14933-00	..SPRING, DIAPHRAGM	1	
22	3GM-1490J-00	..NEEDLE SET	1	
23	3GM-1411A-00	..BLOCK JET ASSY	1	
24	3GM-14153-00	..WASHER, MAIN JET	1	
25	1HX-14566-00	..SCREW	1	
26	3LF-14147-00	..O-RING	1	
27	1AE-14147-00	..O-RING	1	
28	3GM-14997-00	..SEAL	1	

FIG. 54 ALTERNATE (CARBURETOR)

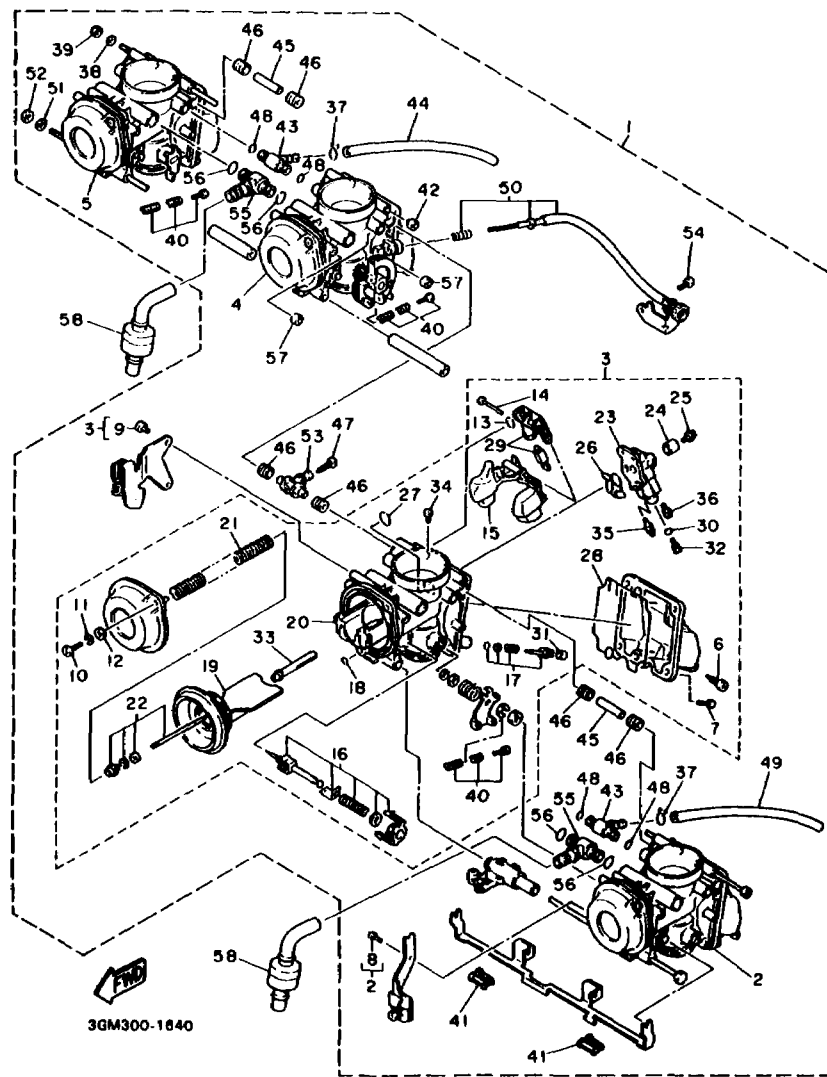

REF. NO.	PART NO.	DESCRIPTION	Q'TY	REMARKS
29	3GM-14107-17	..NEEDLE VALVE SET	1	
30	1AE-14227-00	..O-RING	1	
31	2RJ-14118-00	..CAP	1	
32	3G2-1423A-76	..JET, MAIN (#127.5)	1	UR
	3G2-14231-25	..JET, MAIN (#125)	.1	UR
33	3GM-14141-90	..NOZZLE, MAIN	1	
34	830-14231-25	..JET, MAIN (#125)	1	
35	4G0-14142-37-A0	..JET, PILOT (#37.5)	1	
36	3G2-14231-12	..JET, POWER (# 80)	1	
37	8U9-14139-00	..CLIP, PIPE	2	
38	92901-05600	..WASHER, PLATE	1	
39	95380-05600	..NUT	1	
40	3EN-1490K-00	..STOP SCREW SET	3	
41	3EN-14261-00	..HOLDER	2	
42	3GM-14918-00	..RING	1	
43	17A-14251-00	..NIPPLE	2	
44	2GH-14197-00	..PIPE	1	
45	3GM-14988-00	..PIPE, STARTER CONNECTING	2	
46	3EN-14997-00	..SEAL	6	
47	1KT-14994-00	..NET, FILTER	1	
48	822-14147-00	..O-RING	4	
49	3LF-14197-00	..PIPE	1	
50	3GM-14103-00	..THROTTLE SCREW SET	1	
51	92990-06600	..WASHER, PLATE	1	
52	95380-06600	..NUT	1	
53	3EN-14988-00	..PIPE, STARTER CONNECTING	1	
54	98501-05008	..SCREW, PAN HEAD	1	
55	3GM-14251-00	..NIPPLE	2	

FIG. 55 ALTERNATE (CHASSIS)

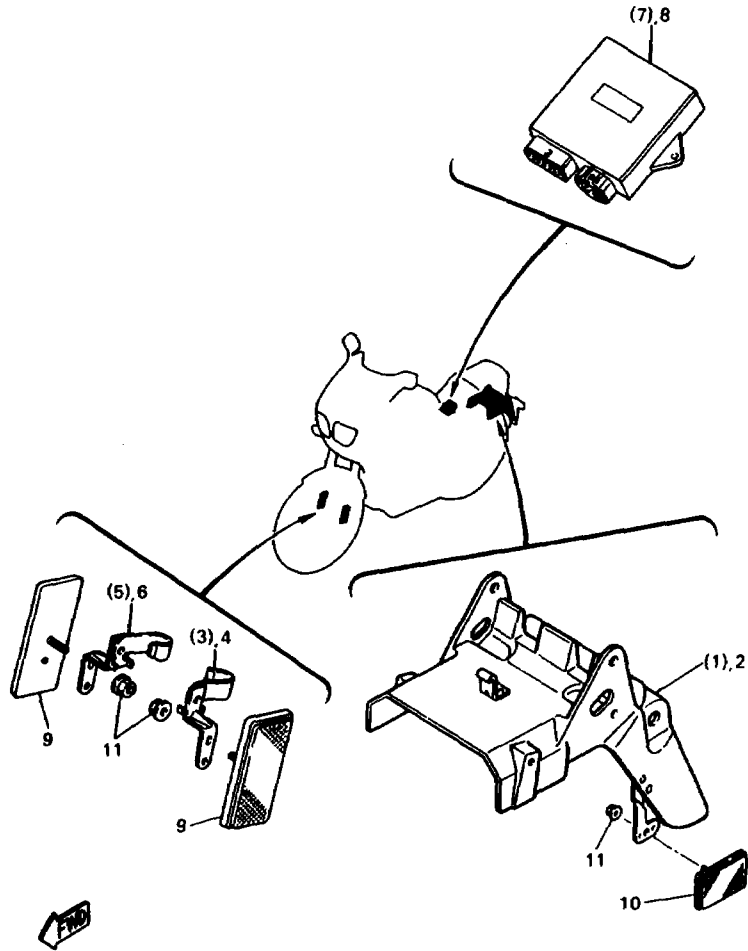

3GME300-4550

REF. NO.	PART NO.	DESCRIPTION	QTY	REMARKS
1	3GM-W2161-01	REAR FENDER COMP.	*	
2	3LE-W2161-01	REAR FENDER COMP.	1	
3	3MA-25876-11	HOLDER, BRAKE HOSE 2	*	
4	3LK-25875-51	HOLDER, BRAKE HOSE 1	1	
5	3MA-25876-21	HOLDER, BRAKE HOSE 2	1	
6	3LK-25876-51	HOLDER, BRAKE HOSE 2	1	
7	3GM-82305-10	IGNITOR UNIT ASSY	*	
8	3LH-82305-10	IGNITOR UNIT ASSY	1	
9	11H-85110-01	REFLECTOR ASSY	2	
10	23V-85110-00	REFLECTOR ASSY	2	
11	95707-05500	NUT, FLANGE	4	

* For Convenience of reference:
Disregard the items asterisked (*) in the "QTY" column. These are intended for GENERAL SPEC, and NOT for INDIVIDUAL SPEC.

FOR SWITZERLAND

The following pages provides a listing of only the parts that meet the specifications peculiar to your market. For those parts not appearing in these pages, refer to the "GENERAL SPEC" section.

FIG. 56 ALTERNATE (CARBURETOR)

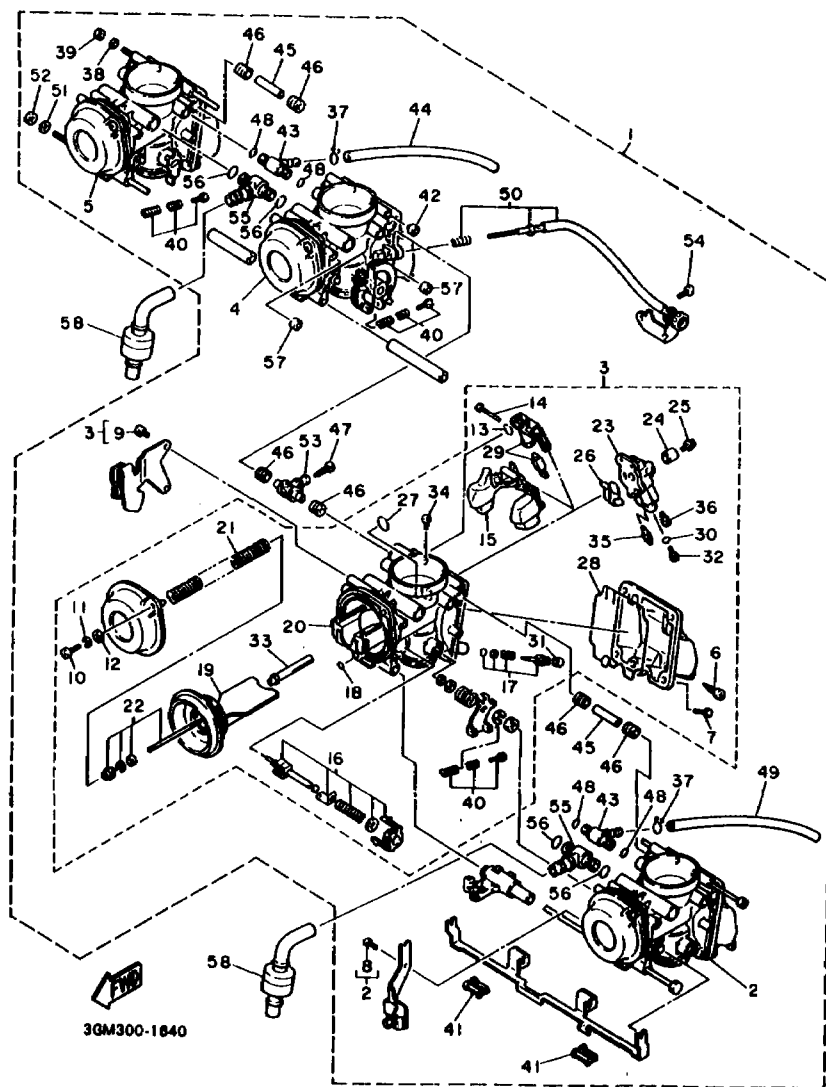

REF. NO.	PART NO.	DESCRIPTION	Q'TY	REMARKS
1	3LH-14900-01	CARBURETOR ASSY	1	
2	3LH-14901-01	..CARBURETOR ASSY 1	1	
3	3LH-14902-01	..CARBURETOR ASSY 2	1	
4	3LH-14903-01	..CARBURETOR ASSY 3	1	
5	3LH-14904-01	..CARBURETOR ASSY 4	1	
6	12R-14191-00	..PLUG, DRAIN	1	
7	98501-06012	..SCREW, PAN HEAD	4	
8	98580-04008	..SCREW, PAN HEAD	1	
9	98580-04008	..SCREW, PAN HEAD	2	
10	98586-06016	..SCREW, PAN HEAD	2	
11	92906-06100	..WASHER, SPRING	2	
12	92906-06600	..WASHER, PLATE	2	
13	3EN-14147-00	..O-RING	1	
14	53L-14186-00	..PIN, FLOAT	1	
15	3GM-14985-00	..FLOAT	1	
16	3EN-1410A-00	..STARTER SET	1	
17	12R-14106-00	..PILOT SCREW SET	1	
18	3FV-14147-00	..O-RING	1	
19	3GM-14940-00	..DIAPHRAGM ASSY	1	
20	3GM-1411E-00	..BLOCK, JET	1	
21	3FV-14933-00	..SPRING, DIAPHRAGM	1	
22	3GM-1490J-00	..NEEDLE SET	1	
23	3GM-1411A-00	..BLOCK JET ASSY	1	
24	3GM-14153-00	..WASHER, MAIN JET	1	
25	1HX-14566-00	..SCREW	1	
26	3LF-14147-00	..O-RING	1	
27	1AE-14147-00	..O-RING	1	
28	3GM-14987-00	..SEAL	1	

FIG. 56 ALTERNATE (CARBURETOR)

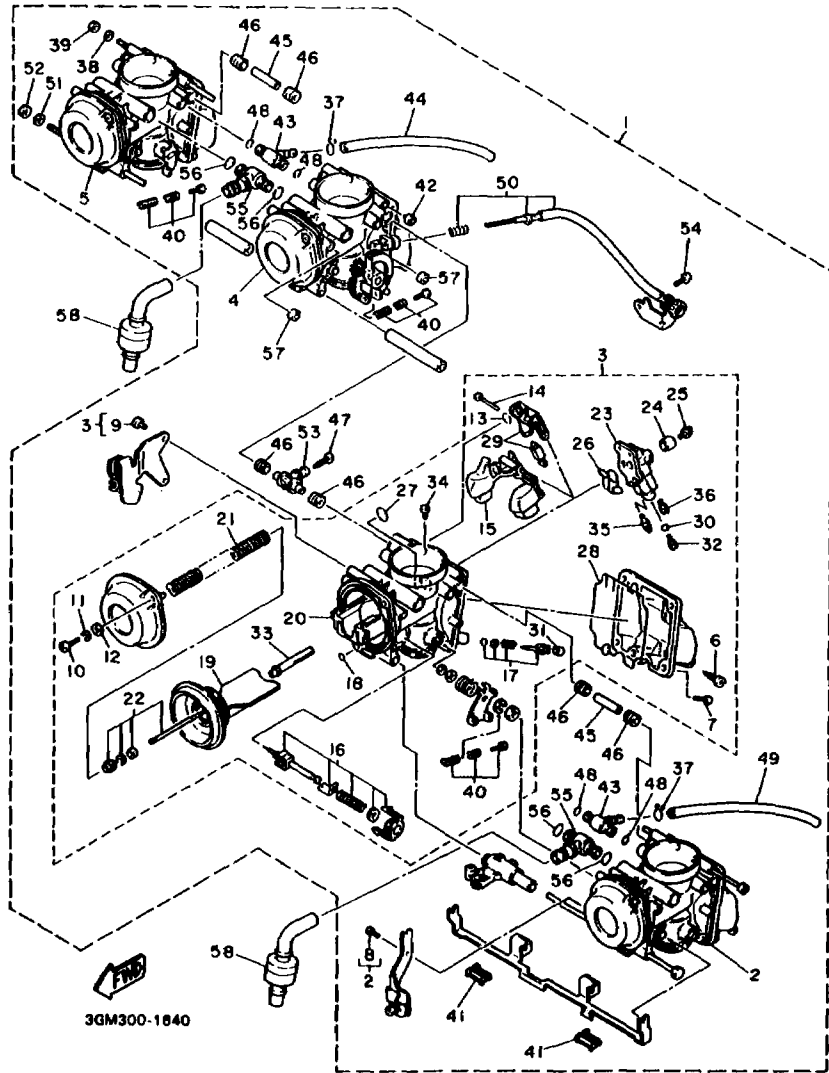

REF. NO.	PART NO.	DESCRIPTION	QTY	REMARKS
29	3GM-14107-17	..NEEDLE VALVE SET	1	
30	1AE-14227-00	..O-RING	1	
31	2RJ-14118-00	..CAP	1	
32	3G2-1423A-76	..JET, MAIN (#127.5)	1	UR
	3G2-14231-25	..JET, MAIN (#125)	1	UR
33	3GM-14141-90	..NOZZLE, MAIN	1	
34	830-14231-25	..JET, MAIN (#125)	1	
35	4G0-14142-37-A0	..JET, PILOT (#37.5)	1	
36	3G2-14231-12	..JET, POWER (# 60)	1	
37	8U9-14139-00	..CLIP, PIPE	2	
38	92901-05600	..WASHER, PLATE	1	
39	95380-05600	..NUT	1	
40	3EN-1490K-00	..STOP SCREW SET	3	
41	3EN-14281-00	..HOLDER	2	
42	3GM-14918-00	..RING	1	
43	17A-14251-00	..NIPPLE	2	
44	2GH-14197-00	..PIPE	1	
45	3GM-14988-00	..PIPE, STARTER CONNECTING	2	
46	3EN-14997-00	..SEAL	6	
47	1KT-14994-00	..NET, FILTER	1	
48	822-14147-00	..O-RING	4	
49	3LF-14197-00	..PIPE	1	
50	3GM-14103-00	..THROTTLE SCREW SET	1	
51	92990-08600	..WASHER, PLATE	1	
52	95380-08600	..NUT	1	
53	3EN-14988-00	..PIPE, STARTER CONNECTING	1	
54	98501-05008	..SCREW, PAN HEAD	1	
55	3GM-14251-00	..NIPPLE	2	

FIG. 56 ALTERNATE (CARBURETOR)

REF. NO.	PART NO.	DESCRIPTION	Q'TY	REMARKS
56	3LK-14147-00	.O-RING	4	
57	3GM-14992-00	.ROD	2	
58	3GM-14197-00	PIPE	2	

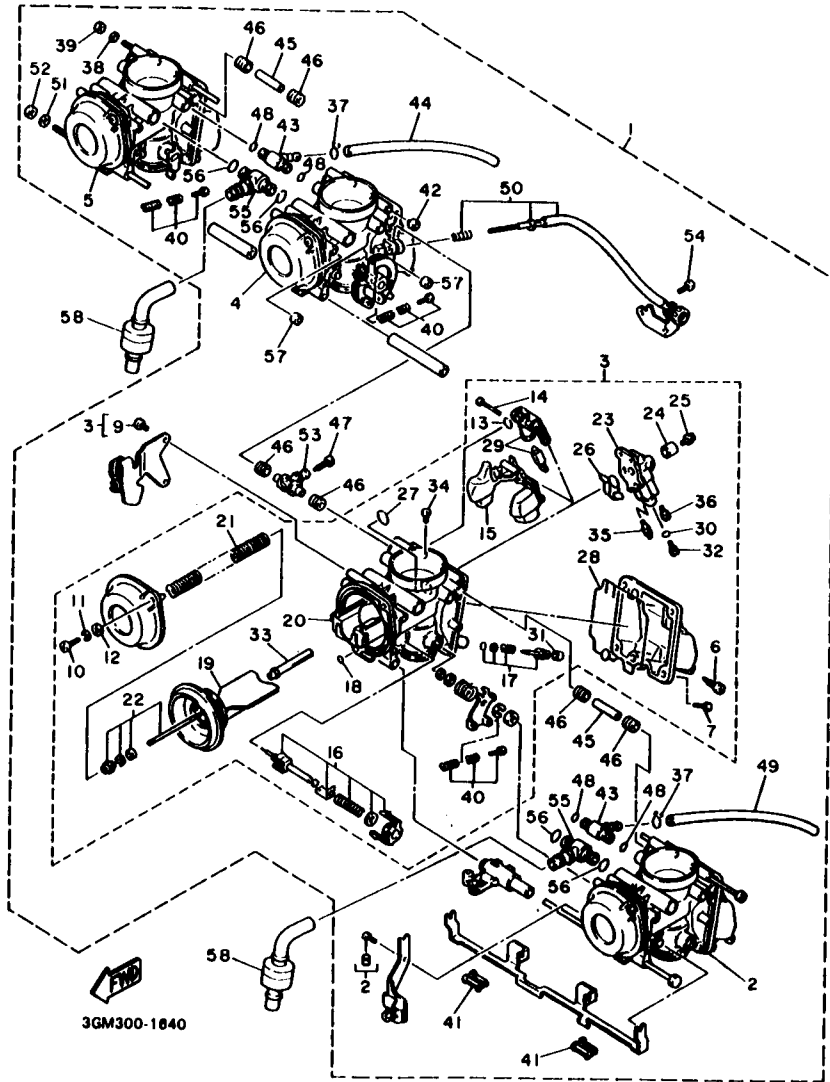
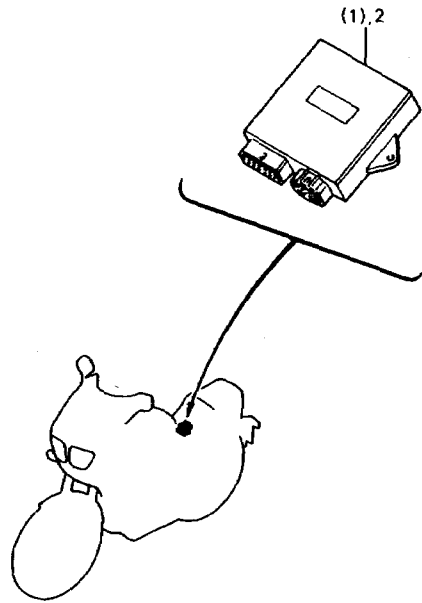

FIG. 57 ALTERNATE (ELECTRICAL)



REF. NO.	PART NO.	DESCRIPTION	QTY	REMARKS
1	3GM-82305-10	IGNITOR UNIT ASSY	*	
2	3LH-82305-10	IGNITOR UNIT ASSY	1	



3GME300-4570

* For Convenience of reference:
Disregard the items asterisked (*) in the "QTY" column. These are intended for GENERAL SPEC, and NOT for INDIVIDUAL SPEC.

H2

FOR ENGLAND

The following pages provides a listing of only the parts that meet the specifications peculiar to your market. For those parts not appearing in these pages, refer to the "GENERAL SPEC" section.

FIG. 58 ALTERNATE (ENGINE)

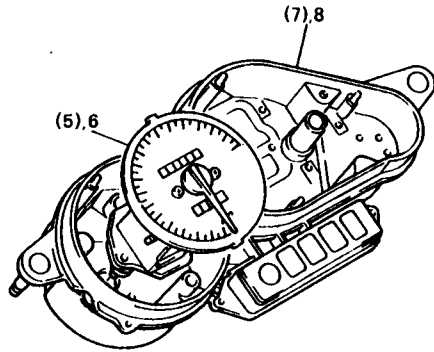

REF. NO.	PART NO.	DESCRIPTION	Q'TY	REMARKS
1	3GM-13597-00	JOINT, CARBURETOR 3	*	
2	3LG-13597-00	JOINT, CARBURETOR 3	2	
3	3GM-13598-00	JOINT, CARBURETOR 4	*	
4	3LG-13598-00	JOINT, CARBURETOR 4	2	
5	4FM-83570-00	SPEEDOMETER ASSY	*	
6	4FM-83570-10	SPEEDOMETER ASSY	1	
7	4FM-8353H-40	CASE, UNDER	*	
8	4FM-8353H-50	CASE, UNDER	1	

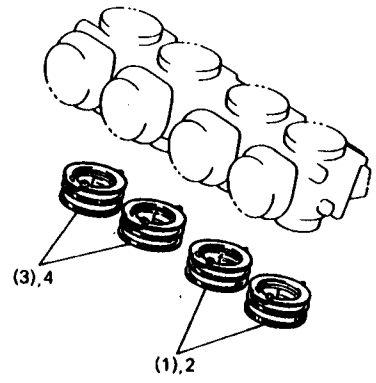

* For Convenience of reference:
Disregard the items asterisked (*) in the "QTY" column. These are intended for GENERAL SPEC, and NOT for INDIVIDUAL SPEC.



3GME300-4580

FIG. 59 ALTERNATE (HEADLIGHT)

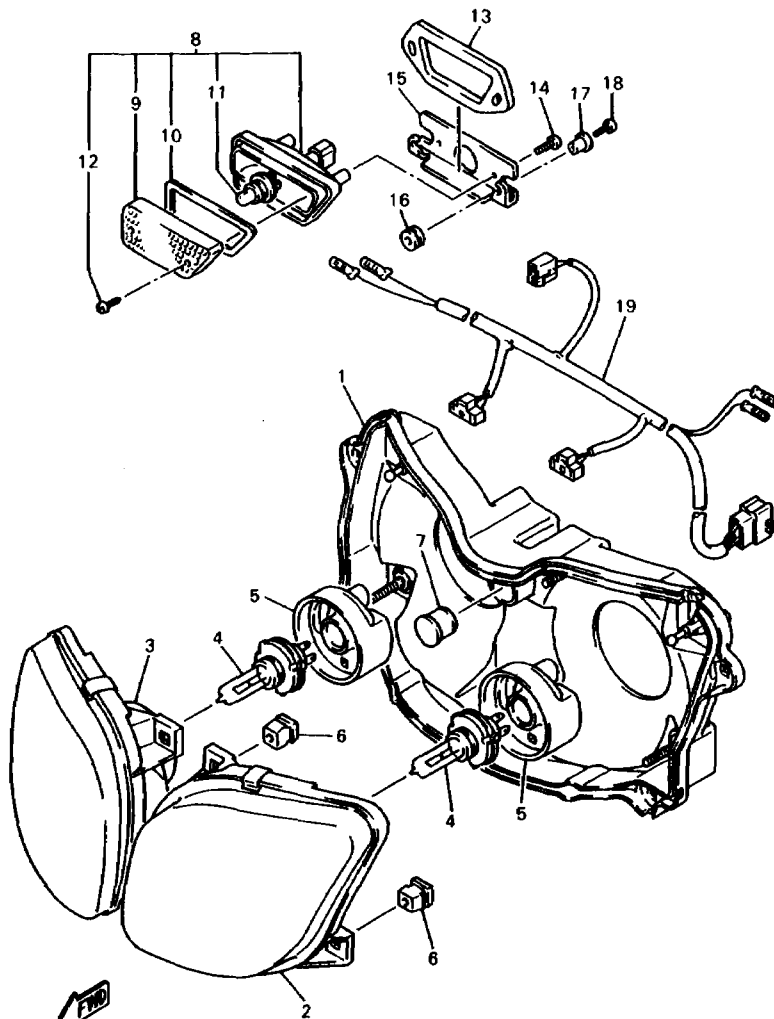

3LE332-4470

REF. NO.	PART NO.	DESCRIPTION	Q'TY	REMARKS
1	4FM-84330-41	BODY ASSY	1	
2	4FM-84320-40	LENS ASSY	1	
3	4FM-8432A-40	LENS ASSY	1	
4	1FM-84314-H0	BULB (12V-35/35W)	2	HALOGEN
5	4JG-84397-00	COVER, SOCKET	2	
6	51L-84334-00	NUT, ADJUSTING	4	
7	90338-24112	PLUG	1	
8	3GM-84301-00	PILOT LIGHT ASSY 1	1	
9	3GM-84321-00	.LENS ASSY	1	
10	3GM-84322-00	.GASKET, LENS	1	
11	2JE-84744-00	.BULB (12V 5W)	1	
12	3GM-84192-00	.SCREW(M4,L=12)	2	
13	3GM-84367-50	DAMPER, HEADLIGHT 2	1	
14	90167-05041	SCREW, TAPPING	2	
15	3GM-8431R-00	STAY, SETTING	1	
16	90480-10517	GROMMET	2	
17	90387-052U6	COLLAR	2	
18	90167-05037	SCREW, TAPPING	2	
19	3GM-84359-40	CORD, HEADLIGHT	1	

H5

FOR HOLLAND

The following pages provides a listing of only the parts that meet the specifications peculiar to your market. For those parts not appearing in these pages, refer to the "GENERAL SPEC" section.

FIG. 60 ALTERNATE (HEADLIGHT)

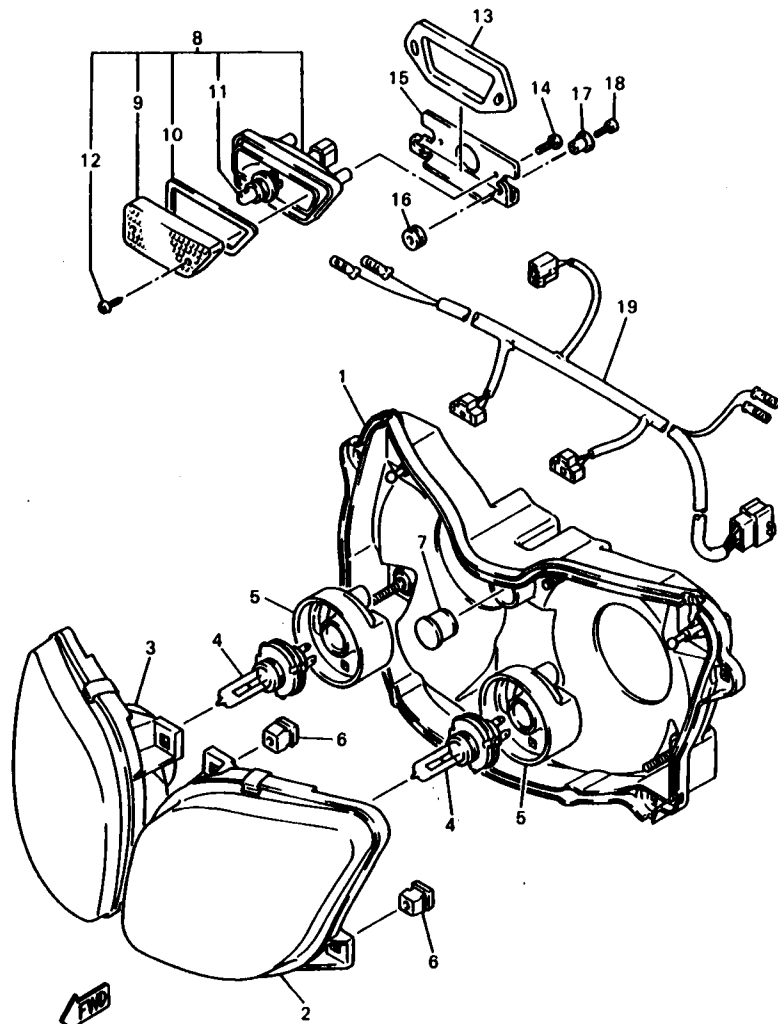

3LE332-4470

REF. NO.	PART NO.	DESCRIPTION	QTY	REMARKS
1	4FM-84330-41	BODY ASSY	1	
2	4FM-84320-10	LENS ASSY	1	
3	4FM-8432A-20	LENS ASSY	1	
4	2F8-84314-00	BULB (12V-60/55W)	2	(H4)HALOGEN
5	4JG-84397-00	COVER, SOCKET	2	
6	51L-84334-00	NUT, ADJUSTING	4	
7	90338-24112	PLUG	1	
8	3GM-84301-00	PILOT LIGHT ASSY 1	1	
9	3GM-84321-00	.LENS ASSY	1	
10	3GM-84322-00	.GASKET, LENS	1	
11	2JE-84744-00	.BULB (12V 5W)	1	
12	3GM-84192-00	.SCREW(M4,L=12)	2	
13	3GM-84367-50	DAMPER, HEADLIGHT 2	1	
14	90167-05041	SCREW, TAPPING	2	
15	3GM-8431R-00	STAY, SETTING	1	
16	90480-10517	GROMMET	2	
17	90387-052U5	COLLAR	2	
18	90167-05037	SCREW, TAPPING	2	
19	3GM-84359-50	CORD, HEADLIGHT	1	

H7

FOR ITALY

The following pages provides a listing of only the parts that meet the specifications peculiar to your market. For those parts not appearing in these pages, refer to the "GENERAL SPEC" section.

FIG. 61 ALTERNATE (HEADLIGHT)

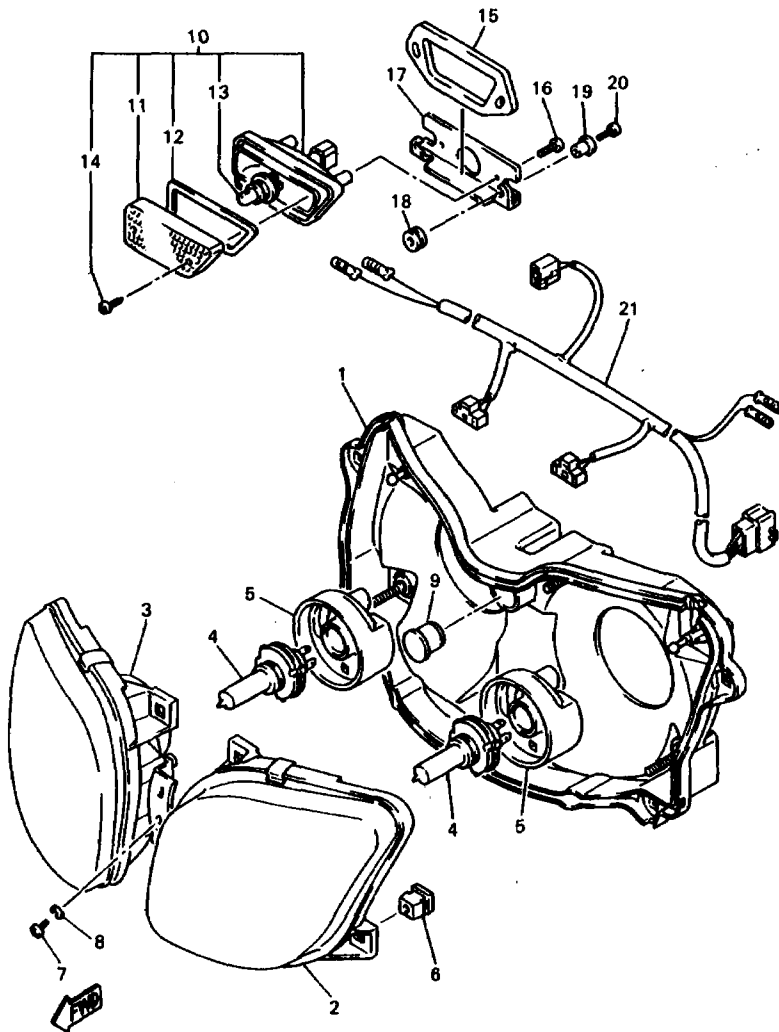

3GME300-4610

REF. NO.	PART NO.	DESCRIPTION	Q'TY	REMARKS
1	4FM-84330-31	BODY ASSY	1	
2	4FM-84320-30	LENS ASSY	1	
3	4FM-8432A-30	LENS ASSY	1	
4	1FM-84314-H0	BULB (12V-35/35W)	2	HALOGEN
5	4JG-84397-00	COVER, SOCKET	2	
6	51L-84334-00	NUT, ADJUSTING	2	
7	98580-04008	SCREW, PAN HEAD	2	
8	92990-04100	WASHER, SPRING	2	
9	90338-24112	PLUG	1	
10	3GM-84301-00	PILOT LIGHT ASSY 1	1	
11	3GM-84321-00	.LENS ASSY	1	
12	3GM-84322-00	.GASKET, LENS	1	
13	2JE-84744-00	.BULB (12V 5W)	1	
14	3GM-84192-00	.SCREW(M4,L=12)	2	
15	3GM-84367-50	DAMPER, HEADLIGHT 2	1	
16	90167-05041	SCREW, TAPPING	2	
17	3GM-8431R-00	STAY, SETTING	1	
18	90480-10517	GROMMET	2	
19	90387-052U5	COLLAR	2	
20	90167-05037	SCREW, TAPPING	2	
21	3GM-84359-40	CORD, HEADLIGHT	1	

H9

FOR OCEANIA

The following pages provides a listing of only the parts that meet the specifications peculiar to your market. For those parts not appearing in these pages, refer to the "GENERAL SPEC" section.

FIG. 62 ALTERNATE (HEADLIGHT)

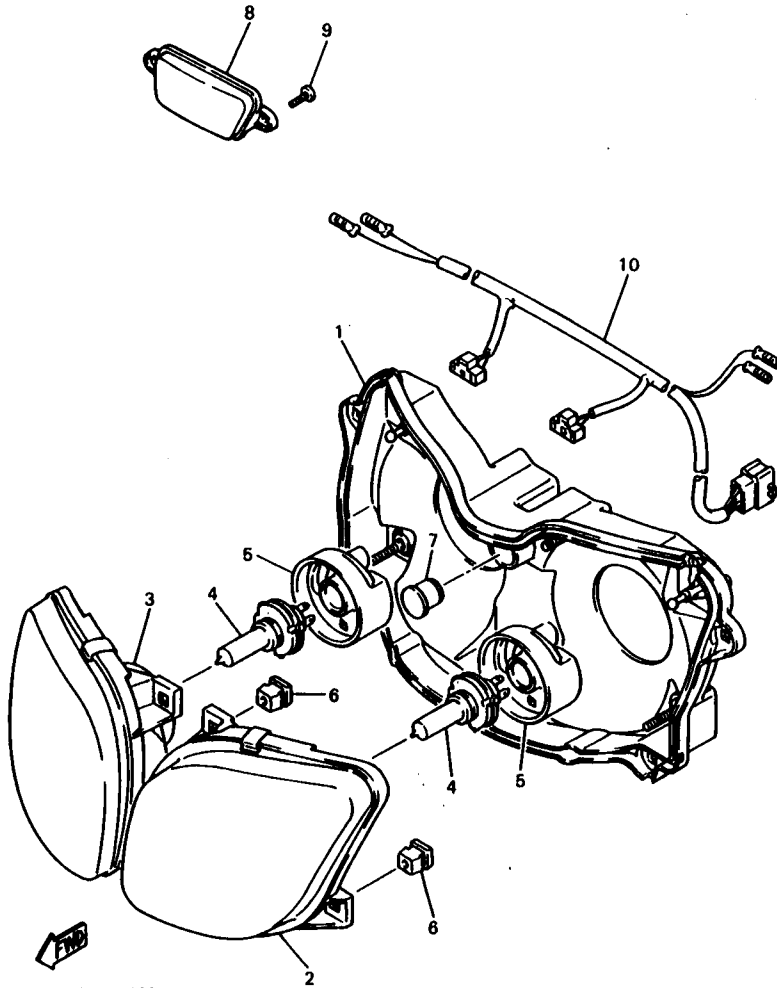

3GME300-4620

REF. NO.	PART NO.	DESCRIPTION	Q'TY	REMARKS
1	4FM-84330-41	BODY ASSY	1	
2	4FM-84320-40	LENS ASSY	1	
3	4FM-8432A-40	LENS ASSY	1	
4	1FM-84314-H0	BULB (12V-35/35W)	2	HALOGEN
5	4JG-84397-00	COVER, SOCKET	2	
6	51L-84334-00	NUT, ADJUSTING	4	
7	90338-24112	PLUG	1	
8	3GM-84378-00-P3	CAP	1	DEEP PURPLE METALLIC
9	90167-05041	SCREW, TAPPING	2	
10	3GM-84359-70	CORD, HEADLIGHT	1	

H11

INDEX

NUMERICAL INDEX

PART NO.	GRID NO.	PART NO.	GRID NO.	PART NO.	GRID NO.
3GM-W0041-50	E - 8	3GM-1133F-51	C - 4	1HX-12168-W1	B - 5
2KR-W0042-50	E - 13	3GM-11361-00	B - 3	1HX-12168-Y1	B - 5
26H-W0045-11	E - 6	3GM-11411-01	B - 4	1HX-12168-00	B - 5
4FM-W0045-20	E - 3	2GH-11416-00	B - 4	1HX-12168-20	B - 5
3MA-W0047-10	E - 3	2GH-11416-10	B - 4	1HX-12168-40	B - 5
31A-W0047-00	E - 6	2GH-11416-20	B - 4	1HX-12168-60	B - 5
4FM-W0047-00	E - 3	2GH-11416-30	B - 4	1HX-12168-80	B - 5
1J3-W0048-00	E - 3	2GH-11416-40	B - 4	1HX-12169-00	B - 6
	E - 6	3GM-11416-00	B - 4	1HX-12169-G0	B - 6
36Y-W0048-00	C - 10	3GM-11416-10	B - 4	1HX-12169-J0	B - 6
31A-W0057-00	E - 6	3GM-11416-20	B - 4	1HX-12169-L0	B - 6
4FM-W0057-00	E - 3	3GM-11416-30	B - 4	1HX-12169-N0	B - 6
4FM-W0057-10	E - 3	3GM-11416-40	B - 4	1HX-12169-T0	B - 6
26H-W0098-00	C - 10	4FM-11456-00	C - 9	1HX-12169-11	B - 5
3GM-W0099-00	E - 10	3GM-11474-00	C - 9	1HX-12169-31	B - 5
3LE-W1741-00	C - 11	3GM-11610-00	B - 4	1HX-12169-50	B - 5
3GM-W1742-00	C - 11	3GM-11610-20	B - 4	1HX-12169-70	B - 6
3GM-W2161-01	D - 3	3GM-11631-00	B - 4	1HX-12169-90	B - 6
3LE-W2161-01	G - 9	3GM-11633-00	B - 4	3GM-12171-00	B - 7
3GM-W247A-F0-P0	D - 15	3GM-11636-00	B - 4	3GM-12176-00	B - 7
3GM-W247A-G0-4B	D - 15	3GM-11650-01	B - 4	3GM-12181-00	B - 7
3GM-W2585-20	E - 10	12R-11654-00	B - 4	3GM-12210-00	B - 7
3GM-W2587-50	E - 8	3GM-11656-00	B - 4	4BE-12213-00	B - 7
3GM-Y2171-R0-P1	D - 5	3GM-11656-10	B - 4	2GH-12241-00	B - 7
3GM-Y2171-S0-4B	D - 5	3GM-11656-20	B - 4	3GM-12251-00	B - 7
3GM-Y2172-L0-P1	D - 5	3GM-11656-30	B - 4	3GM-12252-00	B - 7
3GM-Y2172-M0-4B	D - 5	3GM-12111-00	B - 5	3GM-12405-50	B - 9
3GM-Y2343-30	D - 10	3GM-12112-00	B - 5	3GM-12410-00	B - 9
3GM-Y283G-J0-0X	E - 14	3GM-12113-00	B - 5	3GM-12413-00	B - 9
3GM-Y283G-K0-4B	E - 14	3GM-12114-00	B - 5	3GM-12417-00	B - 9
3GM-Y283J-K0-6X	F - 2	3GM-12116-00	B - 5	1UF-12421-09	B - 8
3GM-Y283J-L0-4B	F - 2	1WG-12117-00	B - 5	3GM-12422-00	B - 8
3GM-Y283K-J0-6X	F - 2	3GM-12117-00	B - 5	11H-12438-00	B - 8
3GM-Y283K-K0-4B	F - 2	1WG-12118-00	B - 5	1AE-12439-00	B - 8
3GM-11102-00	B - 2	1WG-12119-00	B - 5	1UF-12450-00	B - 8
2GH-1111G-00	B - 2	3GM-12121-00	B - 5	3GM-12461-50	B - 9
3GM-11133-10	B - 2	3GM-12126-00	B - 5	22W-12462-00	B - 9
3GM-11134-10	B - 2	1WG-12153-09	B - 6	3DX-12469-00	B - 8
3GM-1115A-00	B - 2	1WG-12153-21	B - 6	4BH-12481-01	B - 8
1AE-11166-00	C - 5	2NK-12153-02	B - 6	3GM-12482-00	B - 8
3GM-11181-00	B - 3	2NK-12153-09	B - 6	2GH-12484-00	B - 9
3GM-11182-00	B - 2	1HX-12168-A0	B - 5	6Y9-12491-00	F - 14
3GM-11191-00	B - 2	1HX-12168-F0	B - 5	3GM-12576-50	B - 9
3GM-11193-00	B - 2	1HX-12168-H1	B - 5	3GM-12579-50	B - 9
214-11198-01	B - 12	1HX-12168-K1	B - 5	3GM-12588-60	B - 9
3GM-11310-00	B - 3	1HX-12168-M1	B - 5	3GM-12589-50	B - 9
4PM-11310-00	B - 3	1HX-12168-R1	B - 5	3GM-12682-50	B - 9
3GM-1133E-51	C - 4	1HX-12168-U1	B - 5	2GH-1316E-00	B - 10

NUMERICAL INDEX

PART NO.	GRID NO.	PART NO.	GRID NO.	PART NO.	GRID NO.
3GM-13161-01	B - 12	3GM-1411E-00	B - 15	53L-14186-00	G - 6
3GM-13171-00	B - 10		F - 15		G - 10
3GM-13174-00	B - 12		G - 6	12R-14191-00	B - 15
3GM-13181-00	B - 10		G - 10		F - 15
3GM-13191-00	B - 10	2RJ-14118-00	G - 7		G - 6
1AE-13300-00	B - 10		G - 11		G - 10
2GH-13329-00	B - 10	8U9-14139-00	C - 2	2GH-14197-00	C - 2
3GM-13337-00	B - 12		G - 2		G - 2
3GM-13411-00	B - 10		G - 7		G - 7
3GM-13412-50	B - 10		G - 11		G - 11
4BH-13414-00	B - 12	3GM-14141-90	C - 2	3GM-14197-00	C - 3
3FV-13416-01	B - 12		G - 2		G - 3
3GM-13417-50	B - 12		G - 7		G - 8
3FV-13440-00	B - 12		G - 11		G - 12
3GM-13454-00	B - 11	4G0-14142-37-A0	G - 7	3LF-14197-00	C - 2
3VD-13455-00	B - 12		G - 11		G - 2
3TJ-13470-00	B - 12	4G0-14142-40	C - 2		G - 7
4BH-13475-00	B - 10		G - 2		G - 11
3KS-13490-00	B - 12	1AE-14147-00	B - 15	1AE-14227-00	C - 2
3GM-13586-00	B - 13		F - 15		G - 2
3GM-13596-00	B - 13		G - 6		G - 7
3GM-13597-00	B - 13		G - 10		G - 11
3LF-13597-00	G - 4	3EN-14147-00	B - 15	3G2-1423A-75-A1	C - 2
3LG-13597-00	G - 14		F - 15	3G2-1423A-76	G - 2
3GM-13598-00	B - 13		G - 6		G - 7
3LF-13598-00	G - 4		G - 10		G - 11
3LG-13598-00	G - 14	3FV-14147-00	B - 15	3G2-14231-12	C - 2
3GM-13907-00	D - 14		F - 15		G - 2
3EN-1410A-00	B - 15		G - 6		G - 7
	F - 15		G - 10		G - 11
	G - 6	3LF-14147-00	B - 15	3G2-14231-25	C - 2
	G - 10		F - 15		G - 2
3GM-14103-00	C - 2		G - 6		G - 7
	G - 2		G - 10		G - 11
	G - 7	3LK-14147-00	C - 2	830-14231-23	C - 2
	G - 11		G - 2		G - 2
	B - 15		G - 8	830-14231-25	G - 7
12R-14105-00	F - 15		G - 12		G - 11
	G - 6	822-14147-00	C - 2	17A-14251-00	C - 2
	G - 10		G - 2		G - 2
3GM-14107-17	C - 2		G - 7		G - 7
	G - 2		G - 11		G - 11
	B - 15	3GM-14153-00	B - 15	3GM-14251-00	C - 2
	F - 15		F - 15		G - 2
	G - 6		G - 6		G - 7
	G - 10		F - 15		G - 2
	G - 10	53L-14186-00	B - 15	3EN-14261-00	C - 2
			F - 15		G - 2

NUMERICAL INDEX

PART NO.	GRID NO.	PART NO.	GRID NO.
3EN-14261-00	G- 7	3LH-14902-01	G- 6
	G-11		G-10
3GM-14294-00	D-14	3GM-14903-00	B-15
3GM-14401-00	B-13	3LF-14903-00	F-15
2GH-14413-00	B- 8	3LH-14903-01	G- 6
3GM-14422-00	B-13		G-10
3GM-14432-00	B-13	3GM-14904-00	B-15
3GM-14443-00	B-13	3LF-14904-00	F-15
3GM-14451-00	B-13	3LH-14904-01	G- 6
36F-14452-00	B-13		G-10
3GM-14453-00	B-13	3GM-14918-00	C- 2
31A-14477-00	D- 3		G- 2
	F-11		G- 7
1HX-14565-00	B-15		G-11
	F-15	3FV-14933-00	B-15
	G- 6		F-15
	G-10		G- 6
3GM-14610-00	C- 4		G-10
3YF-14613-01	C- 4	3GM-14940-00	B-15
3GM-14683-00	C- 4		F-15
3GM-14710-51	C- 4		G- 6
3LE-14710-30	G- 4		G-10
3HE-14755-00	C- 4	3GM-14985-00	B-15
	G- 4		F-15
3GM-14811-00	C- 4		G- 6
3GM-14821-00	C- 4		G-10
4HD-14826-00	C- 4	3EN-14988-00	C- 2
2TK-14845-00	C- 4		G- 2
2TK-14865-01	C- 4		G- 7
2TK-14867-01	C- 4		G-11
3GM-1490J-00	B-15	3GM-14988-00	C- 2
	F-15		G- 2
	G- 6		G- 7
	G-10		G-11
3EN-1490K-00	C- 2	3GM-14992-00	C- 3
	G- 2		G- 3
	G- 7		G- 8
	G-11		G-12
3GM-14900-00	B-15	1KT-14994-00	C- 2
3LF-14900-00	F-15		G- 2
3LH-14900-01	G- 6		G- 7
	G-10		G-11
3GM-14901-00	B-15	3EN-14997-00	C- 2
3LF-14901-00	F-15		G- 2
3LH-14901-01	G- 6		G- 7
	G-10		G-11
3GM-14902-00	B-15	3GM-14997-00	B-15
3LF-14902-00	F-15		F-15

NUMERICAL INDEX

PART NO.	GRID NO.	PART NO.	GRID NO.	PART NO.	GRID NO.	PART NO.	GRID NO.	PART NO.	GRID NO.	PART NO.	GRID NO.
3GM-16351-00	C-10	3GM-16351-00	C-10	3GM-16351-00	C-10	3GM-21446-03	D- 2	3GM-22311-10	D- 7		
3GM-16356-00	C-10	3GM-16356-00	C-10	3GM-16356-00	C-10	3GM-21453-00	E-11	3GM-22321-00	D- 8		
1AE-16357-00	C-10	1AE-16357-00	C-10	1AE-16357-00	C-10	4X7-2149Y-00	B-13	1RK-22483-00	D- 4		
4BH-16371-01	C-10	4BH-16371-01	C-10	4BH-16371-01	C-10	3GM-21511-51-PO	D- 3	3GM-23102-A0	D-11		
1TV-16381-10	C-10	1TV-16381-10	C-10	1TV-16381-10	C-10	3GM-21511-51-4B	D- 3	3GM-23103-A0	D-11		
2GH-17121-00	C-11	2GH-17121-00	C-11	2GH-17121-00	C-11	3GM-21551-A0-PO	D- 3	3GM-23106-A0	D-11		
2GH-17131-00	C-11	2GH-17131-00	C-11	2GH-17131-00	C-11	3GM-21551-A0-4B	D- 3	3GM-23110-A0	D-11		
2GH-17141-00	C-11	2GH-17141-00	C-11	2GH-17141-00	C-11	3GM-21555-A0-PO	D- 3	3GM-23111-A0	D-11		
2GH-17151-00	C-11	2GH-17151-00	C-11	2GH-17151-00	C-11	3GM-21555-A0-4B	D- 3		D-12		
2GH-17211-01	C-11	2GH-17211-01	C-11	2GH-17211-01	C-11	3GM-21575-00	D- 4	3VD-23115-00	D-11		
3GM-17221-00	C-11	3GM-17221-00	C-11	3GM-17221-00	C-11	3GM-21576-00	D- 4	3GM-23117-A0	D-11		
3GM-17231-00	C-11	3GM-17231-00	C-11	3GM-17231-00	C-11	4FM-21596-00	E- 3		D-12		
3GM-17241-00	C-11	3GM-17241-00	C-11	3GM-17241-00	C-11	3GM-21621-00	D- 4	3GM-23120-A0	D-11		
3GM-17251-00	C-11	3GM-17251-00	C-11	3GM-17251-00	C-11	3GM-21629-50	D- 3	3GM-23141-A0	D-11		
278-17424-01	C-12	278-17424-01	C-12	278-17424-01	C-12	3GM-21649-00	D- 4		D-12		
2GH-17460-11	C-11	2GH-17460-11	C-11	2GH-17460-11	C-11	3GM-21649-10	D- 4	3VD-23144-00	D-11		
1AE-18101-01	C-14	1AE-18101-01	C-14	1AE-18101-01	C-14	3MA-21649-00	E-14	3GM-23145-A0	D-11		
2GH-18110-00	C-14	2GH-18110-00	C-14	2GH-18110-00	C-14	3GM-21651-50-PO	D- 3	3GM-23153-A0	D-11		
2GH-18112-01	C-14	2GH-18112-01	C-14	2GH-18112-01	C-14	3GM-21651-50-4B	D- 4		D-12		
132-18113-01	C-14	132-18113-01	C-14	132-18113-01	C-14	3LE-21663-00	D- 4	3GM-23170-A0	D-11		
46X-18115-00	C-14	46X-18115-00	C-14	46X-18115-00	C-14	3LE-21663-10	D- 4	3GM-2331K-A0	D-11		
4G0-18127-00	C-14	4G0-18127-00	C-14	4G0-18127-00	C-14	3LE-2173L-01	D- 5		D-12		
38Y-18140-00	C-13	38Y-18140-00	C-13	38Y-18140-00	C-13	3LE-2173L-10	D- 5	3GM-23340-A0	D-12		
2H9-18154-00	C-14	2H9-18154-00	C-14	2H9-18154-00	C-14	2GH-21732-00	D- 4	3GM-23377-00	E- 9		
3LE-18511-00	C-13	3LE-18511-00	C-13	3LE-18511-00	C-13		D- 5	3GM-23378-00	E- 9		
3LE-18512-00	C-13	3LE-18512-00	C-13	3LE-18512-00	C-13		D-13	3GM-23415-00	D-10		
3LE-18513-00	C-13	3LE-18513-00	C-13	3LE-18513-00	C-13	3LE-2174L-01	D- 5	26H-23418-01	D-10		
4BH-18531-00	C-13	4BH-18531-00	C-13	4BH-18531-00	C-13	3LE-2174L-10	D- 5	3GM-23437-00	D-10		
1AE-18536-00	C-13	1AE-18536-00	C-13	1AE-18536-00	C-13	1FK-21746-00	D- 3	3GM-24110-01-W2	D-13		
4BH-18540-00	C-13	4BH-18540-00	C-13	4BH-18540-00	C-13	3Y6-21747-00	D-14	3GM-24110-01-W3	D-13		
278-18542-00	C-13	278-18542-00	C-13	278-18542-00	C-13	3GM-2177G-50	D- 6	3GM-24136-00	D-14		
278-18566-00	C-13	278-18566-00	C-13	278-18566-00	C-13	3GM-21816-00	D- 6	2GH-24181-00	D-13		
3GM-21110-60	C-15	3GM-21110-60	C-15	3GM-21110-60	C-15	3GM-21871-50	D- 6	3GM-24182-01	D-13		
3GM-21149-00	D- 2	3GM-21149-00	D- 2	3GM-21149-00	D- 2	1AA-21874-00	D- 6	2GH-24183-00	D-13		
3GM-2117A-00	C-15	3GM-2117A-00	C-15	3GM-2117A-00	C-15	4L0-21875-00	D- 6	3Y6-24183-00	D-13		
3GM-2117M-00	C-15	3GM-2117M-00	C-15	3GM-2117M-00	C-15	3GM-22110-00	D- 7	2GH-24184-00	D-13		
3GM-2117N-00	D- 2	3GM-2117N-00	D- 2	3GM-2117N-00	D- 2	3GM-22127-00	D- 7	2GH-24186-00	D-13		
3GM-2117R-00	D- 2	3GM-2117R-00	D- 2	3GM-2117R-00	D- 2	3GM-22128-00	D- 7	2GH-24187-00	D-13		
2GH-2117T-00	C-15	2GH-2117T-00	C-15	2GH-2117T-00	C-15	3GM-22129-00	D- 8	2GH-24191-00	D-13		
3GM-21190-50-33	C-15	3GM-21190-50-33	C-15	3GM-21190-50-33	C-15	3GM-22141-00	D- 7	3LE-24240-01	D-13		
3GM-21249-50	D- 6	3GM-21249-50	D- 6	3GM-21249-50	D- 6	3GM-22151-00	D- 8	3LE-24240-10	D-13		
26H-21308-00	D- 2	26H-21308-00	D- 2	26H-21308-00	D- 2	3GM-2217A-00	D- 7	3GM-24311-01	D-13		
3GM-21347-00	C-15	3GM-21347-00	C-15	3GM-21347-00	C-15	3GM-2217M-00	D- 7	3GM-24312-00	D-13		
3GM-21348-51	C-15	3GM-21348-51	C-15	3GM-21348-51	C-15	3GM-22184-00	D- 7	3PA-24356-00	E- 8		
3GM-21359-00	D- 2	3GM-21359-00	D- 2	3GM-21359-00	D- 2	3GM-22210-10	D- 9	26H-24500-00	D-13		
30X-2139X-00	F- 2	30X-2139X-00	F- 2	30X-2139X-00	F- 2	24X-22261-00	D- 9	214-24512-00	D-13		
34M-2139X-00	E-15	34M-2139X-00	E-15	34M-2139X-00	E-15	24X-22262-00	D- 9	1FK-24560-00	D-13		
3GM-2142K-50	C-15	3GM-2142K-50	C-15	3GM-2142K-50	C-15	3GM-22262-00	D- 9	1FK-24566-00	D-14		

NUMERICAL INDEX

PART NO.	GRID NO.	PART NO.	GRID NO.	PART NO.	GRID NO.
4FM-24602-00	D-14	3GM-25852-50	E-8	4FM-26299-00	E-15
4BH-24705-00	D-15	3FV-25854-00	E-8	3GM-26302-00	E-7
3GM-24718-00	D-15	360-25854-00	E-13	3GM-26331-01	E-7
3GM-24718-50	D-15	55U-25854-00	E-10	3GM-26450-A0	E-10
3GM-24728-50	D-15	2GU-25855-00	E-13	3GM-26455-00	E-10
3GM-24730-60	D-15	2J2-25855-50	E-8	3GM-26464-00	E-10
3GM-24731-50	D-15	2VN-25866-00	E-8	3GM-26470-A0	E-10
2GH-24741-00	D-15	56A-25867-00	E-8	2GH-27211-00	E-13
3GM-24776-50	D-15		E-10	47X-27222-00	E-13
1KT-2478F-00	D-15	3GM-25872-A0	E-8	3GM-27311-00	E-11
3LE-2478M-00	D-15	3GM-25873-A0	E-8	2KT-27315-00	E-11
3LE-2478M-10	D-15	3GM-25874-A0	E-13	3GM-27321-00	E-11
3GM-24796-50	D-15	3GM-25876-50	E-5	1TX-27351-00	E-11
4FM-25149-00	E-2	3LK-25875-51	G-9	3GM-2741L-00	E-11
4FM-25168-00-P2	E-2	3GM-25876-00	E-5	2GH-27410-00	E-11
4FM-25168-00-7B	E-2	3LK-25876-51	G-9	2GH-27413-00	E-11
3GM-25181-A0	E-2	3MA-25876-11	E-9	1UF-27414-00	D-10
4FM-25190-00	E-2	3MA-25876-21	E-9	2H7-27414-00	E-12
3GM-25338-01-PO	E-4		G-9	3GM-2742L-00	E-12
3GM-25338-01-7B	E-4	3FV-2589A-00	E-8	2GH-27420-00	E-11
2GH-25364-00	E-4	3FV-2589F-00	E-8	1HX-27431-00	E-11
36Y-25368-01	E-4	3FV-2589G-00	E-8	1HX-27437-00	E-12
3GM-25371-00	E-4	3GM-2589H-00	E-8	3GM-27441-00	E-12
36Y-25377-00	E-4	3FV-25894-00	E-8	3GM-27442-00	E-11
3GM-25381-A0	E-5	47X-25894-00	E-13	3GM-27443-00	E-11
3GM-25388-00	E-4	3GM-25895-50	E-13	2TK-27813-00	E-13
3GM-25389-00	E-4	29L-25919-A0	E-8	3LE-28100-00	D-4
29L-25398-00	E-2	4FM-25919-00	E-3	4FM-28215-00	E-14
	E-4	3HE-25924-00	E-6	3LE-28301-01	F-2
29L-25398-10	E-2	4FM-25924-00	E-3	3LE-28301-11	F-2
	E-4	3HE-25925-00	E-6	3LE-28303-01	F-2
29L-25398-20	E-2	4FM-25925-00	E-3	3LE-28303-11	F-2
	E-4	3GM-26111-A0	E-7	3GM-2831W-A0	E-14
2GH-25447-22	E-4	3GM-26112-A0	E-7	3GM-2832W-A0	E-14
4FM-2580T-20	E-3	3GM-26113-50	E-7	3LE-28328-00	F-2
4FM-2580U-20	E-3	3GM-26121-51	E-7	3LE-28328-10	F-2
3GM-2580W-10	E-6	3GM-26122-51	E-7	3LE-28338-00	F-2
4FM-2581T-01	E-3	3GM-26131-00	E-8	3GM-2835U-A0	E-15
3GM-25819-00	E-6	4FM-26240-00	E-7	3GM-2835V-A0	E-15
1FK-25827-00	E-6	4FM-26241-00	E-7	3GM-28356-A0	E-14
4FM-25827-00	E-3	36Y-26248-00	E-7	3GM-2836A-00	F-3
1FK-25828-00	E-6	3LN-26270-01	E-7	3GM-2836E-50	F-3
3GM-2583V-00	E-13	4FM-26280-01	E-14	3GM-2836F-00	F-3
2KT-25831-00	E-8	4FM-26280-10	E-14	3GM-2836G-00	F-3
51J-25836-00	E-8	4FM-26290-00	E-14	3GM-2836H-00	E-15
341-26846-00	E-2	4FM-26290-10	E-15	3GM-2836J-00	E-15
3GM-2585F-00	E-8	3GM-26292-50	E-8	3GM-2836K-50-PO	F-3
2KF-25852-50	E-13	3XV-26298-00	E-15	3GM-2836K-50-4B	F-3

NUMERICAL INDEX

PART NO.	GRID NO.	PART NO.	GRID NO.	PART NO.	GRID NO.
4FM-28372-00	D-3	3LH-82305-10	G-13	3TJ-83964-00	F-13
3GM-2838N-A0	E-15	3GM-82310-00	F-11	3GM-83969-01	E-7
3GM-2838R-A0	E-15	3GM-82320-00	F-11	3LJ-83972-00	E-7
3GM-2838T-01	E-15	2KT-82370-00	F-11	4HM-83975-00	E-7
3GM-2838U-01	E-15	4JH-82501-00	F-13	3FV-83980-00	E-8
3GM-28381-A0	E-14	4NA-82501-00	F-13	3GM-83980-00	E-10
3LE-28390-01	E-14	3GM-82509-00	F-13	3GM-84192-00	F-9
3LE-28390-11	E-14	3GM-82530-11	F-13		G-15
3GM-28396-50	E-15	1AE-82540-00	F-11		H-2
3GM-28397-50	E-15	4FM-82541-00	F-11		H-3
3GM-2840F-50	D-15	2EL-82560-00	F-11	3GM-84301-00	F-9
2GH-81600-55	F-4	2KT-82566-01	F-13		G-15
3FV-81604-00	F-4	3GM-82590-30	F-13		H-2
3FV-81619-00	F-4	3LK-82590-20	F-13		H-3
3FV-81634-00	F-4	3MA-82591-00	E-9	3GM-8431R-00	F-9
36Y-81638-50	F-4	3GM-83310-00	F-7		G-15
2KT-81642-50	F-4	306-83311-40	F-7		H-2
36Y-81643-30	F-4	3GM-83320-00	F-7		H-3
36Y-81643-50	F-4	61J-83330-00	F-7	1FM-84314-H0	G-15
2KT-81645-50	F-4	1VU-83332-00	F-7		H-3
3FV-81645-00	F-4	61L-83332-01	F-7		H-4
2GH-81660-52	F-4	61J-83340-00	F-7	2F9-84314-00	F-9
3GM-81670-00	F-5	1VU-83342-00	F-7		H-2
3FV-81675-00	F-4	61L-83342-01	F-7	4FM-8432A-10	F-9
3GM-81800-50	F-6	3GM-83350-00	F-11	4FM-8432A-20	H-2
3GM-81815-50	F-6	18G-83365-00	F-7	4FM-8432A-30	H-3
3HE-81826-00	F-6	3HE-83371-00	F-11	4FM-8432A-40	G-15
3KS-81840-00	F-6	3GM-83509-10	F-8		H-4
11H-81844-00	F-6	2GV-83517-00	F-8	4FM-84320-10	F-9
26H-81847-00	F-6	4FM-83520-00	F-8		H-2
36Y-81910-50	F-4	1FK-83526-00	E-14	4FM-84320-30	H-3
36Y-81940-00	F-13	4FM-8353H-40	F-8	4FM-84320-40	G-15
4BH-8195A-00	F-13	4FM-8353H-50	G-14		H-4
3EN-81950-00	F-13	3GM-83540-20	F-8	3GM-84321-00	F-9
4BH-81970-00	F-4	4FM-83550-00	F-8		G-15
36Y-81972-50	F-4	4FM-83559-00	F-8		H-2
3XW-82100-00	F-13	4FM-83570-00	F-8		H-3
3GM-82115-50	F-13	4FM-83570-10	G-14	3GM-84322-00	F-9
3XW-82116-00	F-13	2GH-83578-00	F-8		G-15
5Y1-82122-00	F-13	4FM-83590-00	F-8		H-2
2T4-82131-00	F-13	11H-83591-00	F-11		H-3
26L-82131-00	D-4	3GM-83912-10	E-10	4FM-84330-31	H-3
1AE-82151-00	F-13	3GM-83922-50	E-8	4FM-84330-41	F-9
2GH-82151-00	F-13	25G-83936-01	F-13		G-15
42X-82151-00	F-13	437-83936-11	D-6		H-2
3GM-82305-10	F-11		E-7		H-4
3GM-83940-00	E-7		E-7		F-9
1WG-83941-00	E-7		E-7		G-15

NUMERICAL INDEX

PART NO.	GRID NO.	PART NO.	GRID NO.	PART NO.	GRID NO.
51L-84334-00	H- 2	90105-09580	C- 5	90152-06014	C- 7
	H- 3	90105-10316	C- 7	90152-06024	C- 7
	H- 4	90105-10638	E- 3	90154-05013	E-15
3GM-84359-40	G-15		E- 6	90154-05059	E-15
	H- 3	90105-10716	C-15		F- 3
3GM-84359-50	F- 9	90109-063F8	C-13	90154-05060	D- 3
	H- 2	90109-064F0	B- 2	90154-06061	F- 3
3GM-84359-70	H- 4	90109-065A8	B- 7	90157-05057	E- 7
3GM-84367-50	F- 9	90109-080G5	F-13	90157-05079	E-11
	G-15	90109-082A1	E- 7	90157-06104	C- 7
	H- 2	90109-083E2	E-11	90159-03102	F- 8
	H- 3	90109-08718	E- 3	90159-06033	D- 4
3GM-84378-00-P3	H- 4		E- 6		D- 6
4JG-84397-00	F- 9	90109-101F1	D- 7		E-13
	G-15		D- 9		F-13
	H- 2	90109-103A9	E-11	90159-06042	D- 4
	H- 3	90109-104E6	E-11	90159-06056	D- 3
	H- 4	90109-112F1	B- 7	90159-06058	D- 2
3GM-84710-20	F-10	90110-05112	D-14	90159-06084	D- 7
31L-84714-00	F-10	90110-06142	B- 9	90159-06108	D- 7
31K-8473A-00	F-10	90110-06145	E- 8		D- 8
2JE-84744-00	F- 9	90110-06158	F-11	90159-06123	C-10
	G-15	90110-08155	E-11	90159-06178	E-15
	H- 2	90110-08177	C- 9	90164-04023	F- 8
	H- 3	90110-08199	E-11	90167-05037	F- 9
4G1-84744-00	F- 8	90110-10168	C-15		G-15
3YF-84751-00	F-10	90110-10169	C-15		H- 2
11H-85110-01	G- 9	90110-10191	C-15		H- 3
23V-85110-00	G- 9	90116-10485	E- 4	90167-05041	E-15
3G1-85130-01	F-12	90116-10531	C- 5		F- 3
4CF-85130-00	F-12	90116-10532	C- 5		F- 9
3GM-85720-00	F-11	90116-10569	C- 6		G-15
3GM-85752-01	F-11	90116-10576	C- 5		H- 2
42X-85753-00	F-11	90119-06063	D- 3		H- 3
3GM-85820-00	F-11		D- 6		H- 4
3GM-87278-A0	F- 8	90119-06108	D- 3	90170-06228	C-14
90101-06576	C- 4	90119-06114	D- 2	90170-20327	C-10
90101-08766	E- 4	90119-08115	C- 4	90176-06072	D-13
90101-10659	D- 7	90119-08187	C- 4	90176-10049	B- 2
90101-12673	D- 7	90149-04278	D- 4	90176-22050	D-10
90105-06153	B- 2	90149-05273	E-14	90179-05523	E-14
90105-06541	B- 2	90149-06011	D-13		F- 3
90105-06584	E-11		F-11	90179-06499	E-14
90105-07342	B- 7	90149-06150	D- 2	90179-08327	B- 4
90105-08321	E- 5	90149-06287	E-10	90179-08410	C- 4
90105-08852	E-14	90150-05023	E-14	90179-10247	C-15
90105-09373	C- 5	90151-06014	C- 6	90179-10584	B- 2
90105-09556	C- 5	90152-05021	F-13	90179-10590	C-15

NUMERICAL INDEX

PART NO.	GRID NO.	PART NO.	GRID NO.	PART NO.	GRID NO.
90214-12033	C-12	90215-20231	E- 2	90215-21022	D-10
90215-20231	E- 2	90215-21022	D-10	90240-08013	E-15
90215-21022	D-10	90240-08013	E-15	90267-40054	F- 3
90240-08013	E-15	90267-40076	D- 3	90267-07043	E-11
90267-40054	F- 3	90267-07043	E-11	90338-15202	D- 7
90267-40076	D- 3	90338-15202	D- 7	90338-24112	D- 4
90267-07043	E-11	90338-24112	D- 4		F- 8
90338-15202	D- 7		B-10		B-10
90338-24112	D- 4		B- 9		H- 3
			F-10		H- 4
90340-14068	C-13	90340-18101	E-13	90380-10195	C- 4
90340-18101	E-13	90380-10195	C- 4	90387-052U5	F- 9
90380-10195	C- 4	90387-052U5	E-14		G-15
90387-052U5	F- 9		C- 5		H- 2
			D- 2		H- 3
			D- 2		H- 2
			E- 9		90430-10171
			E-10		C- 5
90387-05383	E-10	90387-060M9	E-13	90445-08740	B-13
90387-060M9	E-13	90387-06024	B- 2	90445-096E8	B- 9
90387-06024	B- 2	90387-0604T	D- 7	90445-102G7	D-14
90387-0604T	D- 7	90387-061M0	F-10	90445-11288	B-13
90387-061M0	F-10		C- 4	90445-114E2	B-13
			C- 4	90445-114E2	B-13
			E-12	90446-17348	E-13
			C-14	90460-22052	B- 9
			D- 7	90450-38040	B- 9
			C-10	90450-57034	B-13
			D- 7	90450-67066	B-13
			E- 5	90462-08158	C- 6
			C-11	90462-08184	C- 6
			E- 7	90464-13073	F-13
			D- 3	90464-13080	F-13
			E-15	90464-30040	F-11
			F- 3	90465-08076	B-12
			D-13	90467-08003	B- 9
			F-11	90467-09006	D-14
			D- 3	90467-10008	B-13
			D-10	90467-12124	D-13
			E-11	90467-13123	D-14
			C- 7	90467-14015	C- 5
			E- 7	90467-14057	E-13
			B- 2	90467-15054	C- 5
			C-11	90480-01401	D- 5
			C-11	90387-126T1	D- 6
			E-11	90387-202X9	D- 4

NUMERICAL INDEX

PART NO.	GRID NO.	PART NO.	GRID NO.	PART NO.	GRID NO.
90480-10297	B - 9	91318-06020	B -13	92995-06100	D -13
90480-10517	F - 9	91318-06050	B -10		D -15
	G -15	91318-10045	C -15		E - 5
	H - 2	91490-20020	E - 5	93101-12060	B - 8
	H - 3		E -13	93101-18131	D - 7
90480-13163	D -14	92011-06010	C - 7	93102-12321	C -14
90480-13398	E -14	92011-08030	E -13	93102-28021	E - 2
	F - 2	92901-04600	E - 8	93102-35423	C -11
90480-14023	B -13		E -13	93105-45017	E - 2
90480-14229	E -14		F - 8	93106-30029	E - 4
90480-14412	F -11	92901-05100	F - 4	93106-35030	E - 4
90480-14585	F - 8		F -11	93109-08061	C -10
90480-15058	D - 6	92901-05600	C - 2	93109-12053	C -14
90480-15259	F -10		F - 4	93210-06632	B -10
90480-15363	B - 9		G - 2		C - 8
90480-17359	D - 9		G - 7		C -10
90480-18276	F -10		G -11	93210-06714	B -12
90480-22084	D - 5	92901-06600	D - 3	93210-07135	B -10
	D - 6	92906-05100	B -15		C - 5
90480-22362	D - 6		F -15	93210-14369	C - 8
90480-35526	D - 2		G - 6	93210-14579	B -12
	F - 3		G -10	93210-15586	B -12
90501-04623	C - 9	92906-05600	B -15	93210-15620	E - 8
90501-06022	C -13		F -15		E -13
90501-12743	E -11		G - 6	93210-16N52	D -11
	E -12		G -10		D -12
90501-230E4	C -10	92906-06600	C - 4	93210-16629	B -12
90506-18224	E -11		E - 8	93210-18417	B - 8
90506-28225	E -11		E -10	93210-19216	F - 5
90508-20737	E -13	92980-03100	F - 8	93210-20573	C - 8
90508-26681	C -13	92980-04100	E - 8	93210-23787	B - 8
90508-32682	C -14		E -13		B - 9
90560-12191	C -14		F - 8	93210-27778	C - 5
90560-20357	E - 4		H - 3		C - 7
90560-25270	C -10	92980-05200	C - 4	93210-29196	F -11
91026-06010	D - 2	92990-06200	D -15	93210-30694	B - 8
91311-05010	D -14	92990-06600	B -13	93210-33133	B - 8
91311-06045	E -12		C - 2	93210-44545	B -13
91311-08025	E - 7		C -15	93210-77363	B - 3
91311-08030	D -10		D -15	93210-87723	B -12
91311-08040	D -11		F -12	93305-30601	C -11
	D -12		G - 2	93308-00106	B - 8
91311-10025	D -11		G - 7	93308-00420	E - 2
91312-08012	B -13		G -11	93308-20335	C - 9
91316-08010	E - 9	92990-08200	C -15	93308-20455	C -11
91316-06012	E - 7	92995-06100	D - 3		C -12
	E - 9		D - 8	93308-20541	C - 9
91316-08016	E -14		D - 9	93308-30416	E - 4

NUMERICAL INDEX

PART NO.	GRID NO.	PART NO.	GRID NO.	PART NO.	GRID NO.
93306-30437	E - 4	95023-06040	B - 8	95706-05500	E -14
93306-30525	C -11		C - 7	95706-06500	B - 9
93306-30562	E - 4	95026-06010	B -12		E -10
93310-340N8	C -10	95026-06012	B -10		E -15
93317-41781	D - 7		B -12	95706-10500	D - 2
93317-42060	D - 7	95026-06016	C - 9	95706-12500	F - 7
93317-52865	D - 7		E -14	95707-05500	G - 9
93332-00001	D -10		F -10	95811-06010	F -11
93332-00008	D -10		F -11	95811-06012	D - 6
93340-21505	C -10	95026-06030	B -10		D -14
93399-99919	D - 7		C -10	95811-06016	B -10
93440-10153	B - 2	95026-06090	C -10		C -13
93440-25084	C -11	95303-08700	E -13	95811-06025	F - 6
93440-28062	C -11	95306-12600	F - 7	95811-06030	B -14
93440-45144	C -12	95307-08600	E - 4	95811-06035	C - 5
93450-19095	B - 4	95307-10600	D -11		F -11
93450-52134	D -11		D -12	95811-06060	C - 5
93501-04011	E -12	95316-06800	F - 8	95811-06080	C - 5
93511-32027	C -10	95380-05600	C - 2	95811-06140	C - 5
93604-10011	B - 8		G - 2	95811-08045	C - 5
93615-12088	C - 9		G - 7	95811-08055	C - 5
93900-00030	E - 2		G -11	95811-08080	C - 5
	E - 4	95380-06600	C - 2	95811-08085	C - 5
	E - 2		F -10	95811-08090	C - 5
94113-174U1	E - 4		G - 2	95814-06075	D -13
94117-173U6	E - 4		G - 7	95816-06012	E - 9
94571-31110	E - 4		G -11	95816-06014	C - 9
94581-01108	B - 7		C -14	95816-06025	B - 9
94581-57110	E - 4	95380-06700	E -12	95816-08025	C - 4
94681-01021	B - 7	95601-06100	D - 7		G - 4
94701-00222	B - 2	95601-10200	D - 9	95816-08030	F - 4
94701-00333	B - 2		E - 4	95816-08035	C - 4
95021-08050	B - 8		E - 5	95821-08025	E -12
	C - 7	95601-18200	D - 4	95826-06020	C -14
95023-06010	B - 8	95606-04100	E -13	95827-08035	D -12
95023-06012	B - 2	95611-08100	B - 2	97001-06040	D - 9
	B - 3	95611-08625	D - 7	97011-06010	E - 5
	B - 8	95611-10100	D - 7	97011-06020	D - 3
	C - 6	95611-12100	E - 8		F -12
	F - 5	95616-06100	F -10	97011-06025	D -13
95023-06020	B - 8		D -15	97011-08030	D -13
	C - 8	95701-05500	F -12	97013-06012	C -15
	B - 2		F -13		D - 8
	B - 7		D -14	97013-06035	C -15
	B - 8	95701-06500	D -15	97016-06025	E - 8
	B - 9		F -13		E -10
	B - 8		E - 6	97021-06030	E - 5
	B -12	95701-08500	E -12	97021-08035	C -15
	C - 8	95701-10500			

NUMERICAL INDEX

NUMERICAL INDEX

NUMERICAL INDEX		NUMERICAL INDEX		NUMERICAL INDEX		NUMERICAL INDEX	
PART NO.	GRID NO.	PART NO.	GRID NO.	PART NO.	GRID NO.	PART NO.	GRID NO.
97026-08035	C-15	99228-00140	D-13				
97095-08016	D-3	99236-00100	E-14				
97395-05012	C-4	99237-00080	D-4				
97706-40012	F-8	99237-00100	E-14				
97706-40512	E-15	99510-08012	B-10				
97706-40620	F-7		C-7				
97902-04122	F-8		C-10				
98501-05008	C-2	99510-08016	B-2				
	F-11		B-12				
	G-2	99510-12016	C-8				
	G-7	99510-14016	B-3				
	G-11	99530-10014	B-2				
98501-05012	B-15		C-5				
	F-15						
	G-6						
	G-10						
98506-05030	E-7						
98506-05040	E-7						
98511-04012	E-8						
	E-13						
98511-08012	D-15						
98511-08140	B-13						
98580-03010	F-8						
98580-04008	B-15						
	F-15						
	G-6						
	G-10						
	H-3						
98580-04010	F-8						
98580-05018	F-4						
98580-06010	C-7						
	D-15						
98580-08016	F-11						
98580-08020	C-7						
98586-05016	B-15						
	F-15						
	G-6						
	G-10						
98701-05012	C-13						
98706-04012	E-10						
98706-04018	E-10						
98706-08025	E-15						
98780-05018	F-13						
98901-06008	B-12						
98906-06008	E-7						
99006-10800	C-14						
99009-10400	B-12						
99009-12400	B-8						