

PARTS CATALOGUE

YZF-R1 (5PW7) EUROPE,S.AFRICA

YAMAHA
GENUINE
Parts & Accessories

1B5PW-300E1

YZF-R1
PARTS CATALOGUE
E 2002 by Yamaha Motor Co., Ltd.
1st Edition, August 2002
All rights reserved.
Any reprinting or unauthorized use
without the written permission of
Yamaha Motor Co., Ltd.
is expressly prohibited.
Printed in Japan



A4

FOREWORD

This Parts Catalogue is related to the parts for the model(s) in the below frame. When you are ordering replacement parts, please refer to this Parts Catalogue and quote both part numbers and part names correctly.

YZF-R1(5PW7)

1. Modifications or additions which have been made after issue of the Parts Catalogue will be announced in the Yamaha Parts News.
It is advisable that you make necessary corrections to the Parts Catalogue according to the Yamaha Parts News.

2. Abbreviations

The Following abbreviations are used in this Parts Catalogue.

“UR” Use specified parts number.

“UN” Use as many as needed.

“AP” Alternate Parts

“LM” Local Made (Parts need to be ordered locally)

“F#” Frame No. (Applicable machine No.)

3. Parts, which are to be supplied in an assembly, are listed with a dot(.) in front of the part name as shown below.

EXAMPLE

CARBURETOR ASSY

.JET, PILOT

.NOZZLE, MAIN

4. Number of component for assembly

The numeral appearing to the right of each component part indicates the quantity of parts for each assembly unit.

EXAMPLE

PART NO.	DESCRIPTION	Q'TY	REMARKS
2F5-83310-60	FRONT FLASHER LIGHT ASSY	2	
115-83311-60	.BULB (6V-18W)	1	
1M1-83309-60	.REFLECTOR	1	

5. Applicable colors of graphics are represented in the “REMARKS” as shown below.

PART NO.	DESCRIPTION	Q'TY	REMARKS
2N4-24110-00-X5	.FUEL TANK COMP.	2	MXR
3J1-24240-10	.GRAPHIC, FUEL TANK	1	for MXR

6. Applicable Serial No.

Engine Serial No.

Frame Serial No.

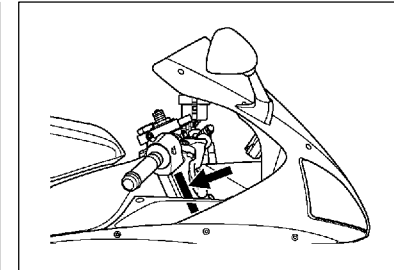
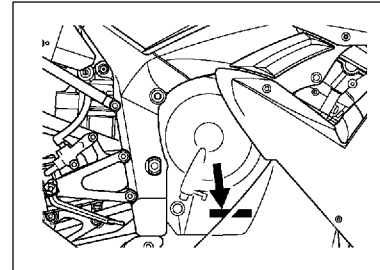

7. Note that the illustrations for reference in finding parts numbers, not to be used for assembling. When assembling, please use the applicable service manual.

8. The asterisk (*) before a reference number indicates modification items after the first edition.

MODEL LABEL

(1) A label called "Model Label" is affixed in the location as indicated in (3) below.
When using this parts catalogue, please be sure to cross-refer the "model code – production code No." in the catalogue to the "model code – production code No." indicated on the Model Label affixed onto the product concerned.

(2) "Model Label" Indication

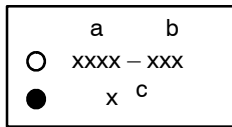

a: Model Type Code
b: Production Code No.
c: Colouring Type

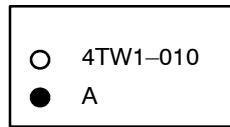

(3) Model Label Affixing Location

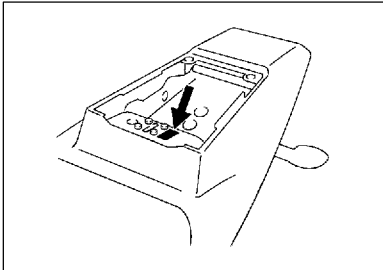

(4) Model Code – Production Code Number of Model Listed in This Parts Catalog

Model Code	Production Code No.	Country (destination)	Model Code	Production Code No.	Country (destination)
5PW7	010	ITALY			
	020	AUSTRIA			
	030	BELGIUM			
	040	SWITZERLAND			
	070	ENGLAND			
	080	GREECE			
	090	HOLLAND			
	100	PORTUGAL			
	110	SWEDEN			
	120	S.AFRICA			

(5) Colouring Information

Model Code	Colouring type code	Colour code	Colour Name	Abbreviation
5PW7	A	0121	VIVID RED COCKTAIL 1	VRC1
	B	0564	DEEP PURPLISH BLUE METALLIC C	DPBMC
	C	0791	SILVER 3	S3

FIG. 1 CYLINDER

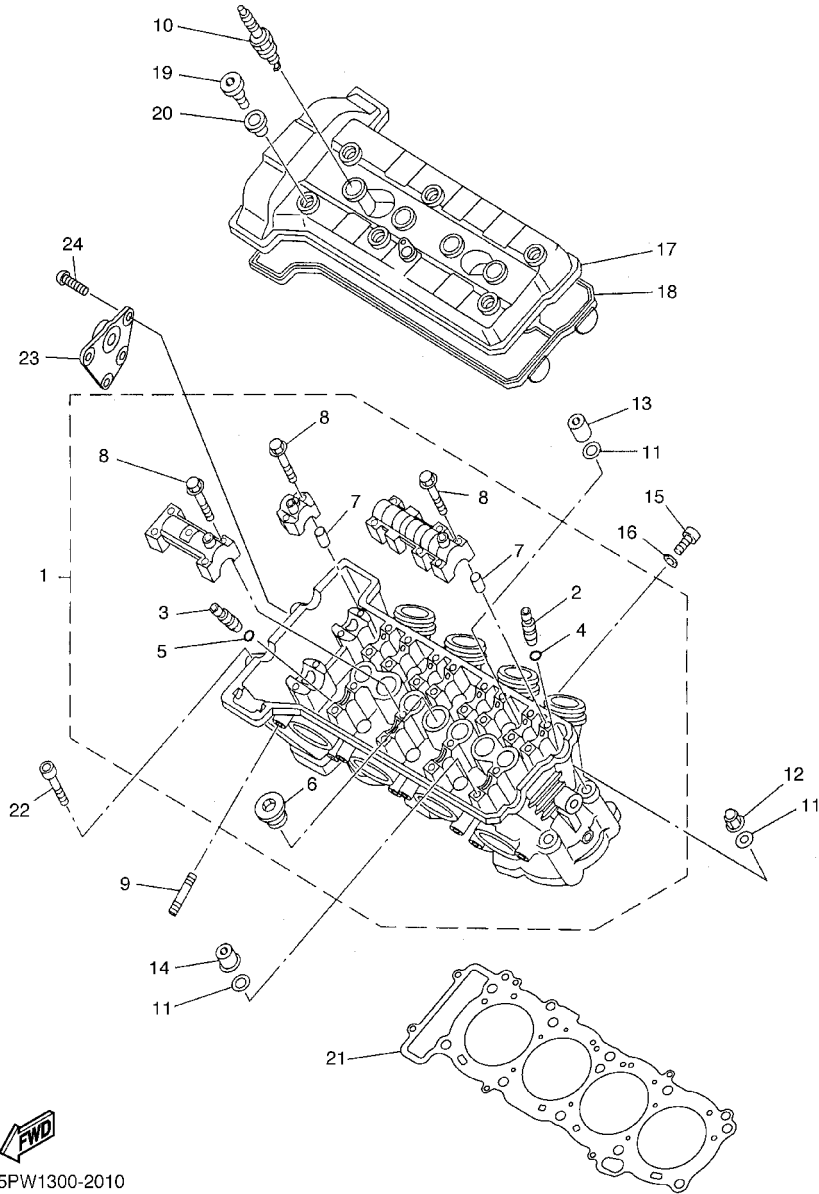

5PW1300-2010

REF. NO.	PART NO.	DESCRIPTION	5PW7				REMARKS
1	5PW-11101-01	CYLINDER HEAD ASSY	1				
2	3TJ-11133-10	.GUIDE, INTAKE VALVE	12				
3	1WG-11133-11	.GUIDE, INTAKE VALVE	8				
4	93440-07149	.CIRCLIP	12				
5	93440-10153	.CIRCLIP	8				
6	90340-27001	.PLUG, STRAIGHT SCREW	1				
7	91808-16023	.PIN, DOWEL	12				
8	90105-06026	.BOLT, FLANGE	28				
9	95617-08625	BOLT, STUD	8				
10	94701-00407	PLUG, SPARK (ND IU27D)	4				UR
	94701-00408	PLUG, SPARK (NGK IR CR9EIA 9)	4				UR
11	90201-10013	WASHER, PLATE	10				
12	90176-10075	NUT, CROWN	2				
13	90179-10006	NUT	3				
14	90179-10414	NUT	5				
15	95024-06012	BOLT, FLANGE	1				
16	90430-06014	GASKET	1				
17	5PW-11191-00	COVER, CYLINDER HEAD 1	1				
18	5PW-11193-00	GASKET, HEAD COVER 1	1				
19	90109-066F0	BOLT	6				
20	4KG-1111G-00	RUBBER, MOUNT 1	6				
21	5PW-11181-00	GASKET, CYLINDER HEAD 1	1				
22	91317-06060	BOLT	2				
23	5PW-11119-00	HANGER, ENGINE	1				
24	90149-06020	SCREW	4				

FIG. 2 CRANKSHAFT. PISTON

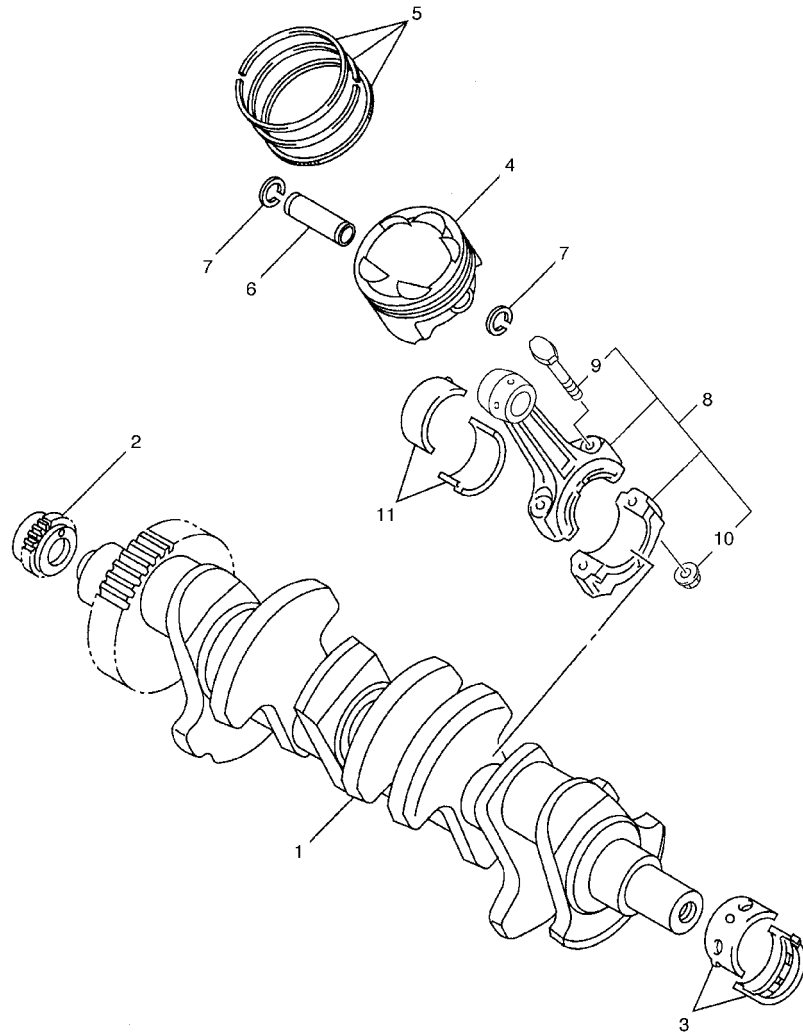

REF. NO.	PART NO.	DESCRIPTION	5PW7				REMARKS
1	4XV-11411-00	CRANKSHAFT	1				
2	4XV-11549-00	SPROCKET, CAM CHAIN	1				
3	3GM-11416-00	PLANE BEARING, CRANKSHAFT 1	10				UR BLUE
	3GM-11416-10	PLANE BEARING, CRANKSHAFT 1	10				UR BLACK
	3GM-11416-20	PLANE BEARING, CRANKSHAFT 1	10				UR BROWN
	3GM-11416-A0	PLANE BEARING, CRANKSHAFT 1	10				UR WHITE
	3GM-11416-B0	PLANE BEARING, CRANKSHAFT 1	10				UR PURPLE
4	4XV-11631-10	PISTON (STD)	4				
5	5LV-11603-00	PISTON RING SET (STD)	4				
6	4XV-11633-00	PIN, PISTON	4				
7	90468-12069	CLIP	8				
8	5PW-11650-00	CONNECTING ROD ASSY	4				
9	5JW-11654-00	.BOLT, CONNECTING ROD	2				
10	90179-08327	.NUT	2				
11	3GM-11656-00	PLANE BEARING, CONNECTING ROD	8				UR BLUE
	3GM-11656-10	PLANE BEARING, CONNECTING ROD	8				UR BLACK
	3GM-11656-A0	PLANE BEARING, CONNECTING ROD	8				UR WHITE
	3GM-11656-B0	PLANE BEARING, CONNECTING ROD	8				UR PURPLE



5PW1300-2020

FIG. 3 VALVE

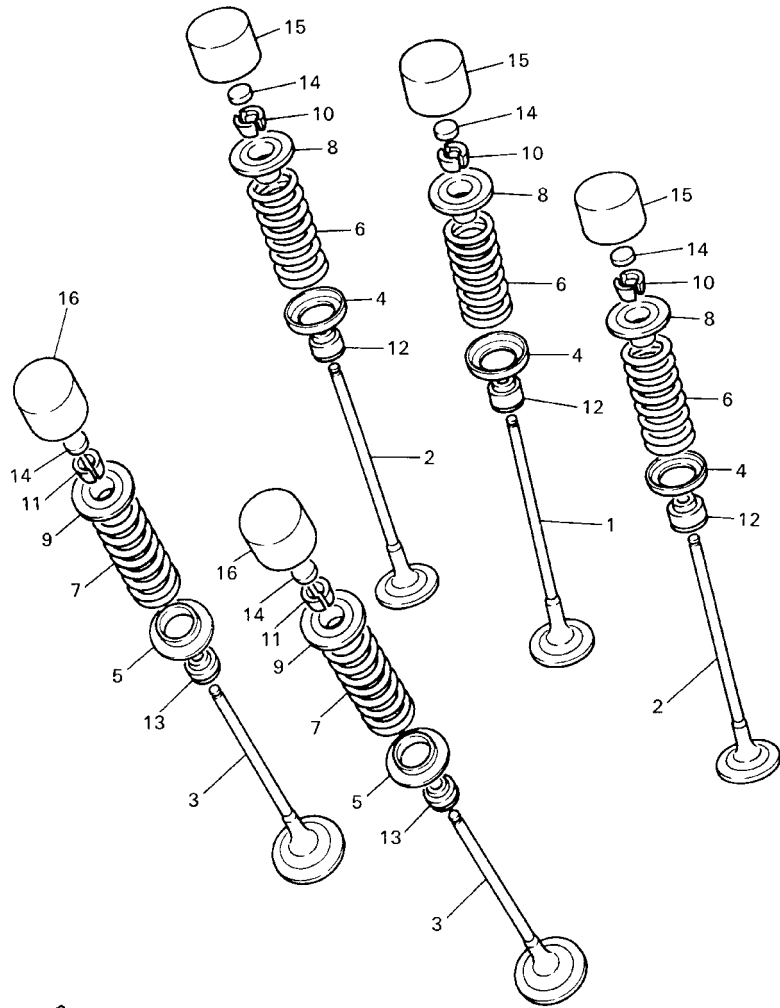

4XV352-8030

REF. NO.	PART NO.	DESCRIPTION	SPW7				REMARKS
1	4XV-12111-00	VALVE, INTAKE	4				
2	4XV-12112-00	VALVE, INTAKE 2	8				
3	5LV-12121-00	VALVE, EXHAUST	8				
4	1HX-12116-01	SEAT, VALVE SPRING	12				
5	3GM-12126-00	SEAT, VALVE SPRING 2	8				
6	4XV-12113-00	SPRING, VALVE INNER	12				
7	4XV-12114-00	SPRING, VALVE OUTER	8				
8	1HX-12117-00	RETAINER, VALVE SPRING	12				
9	1WG-12117-00	RETAINER, VALVE SPRING	8				
10	1HX-12118-00	COTTER, VALVE	24				
11	1WG-12118-00	COTTER, VALVE	16				
12	4TV-12119-00	SEAL, VALVE STEM	12				
13	4SV-12119-00	SEAL, VALVE STEM	8				
14	1HX-12168-00	PAD, ADJUSTING 2 (1.20)	20				UR
	1HX-12168-20	PAD, ADJUSTING 2 (1.25)	20				UR
	1HX-12168-40	PAD, ADJUSTING 2 (1.30)	20				UR
	1HX-12168-60	PAD, ADJUSTING 2 (1.35)	20				UR
	1HX-12168-80	PAD, ADJUSTING 2 (1.40)	20				UR
	1HX-12168-A0	PAD, ADJUSTING 2 (1.45)	20				UR
	1HX-12168-F0	PAD, ADJUSTING 2 (1.50)	20				UR
	1HX-12168-H1	PAD, ADJUSTING 2 (1.55)	20				UR
	1HX-12168-K1	PAD, ADJUSTING 2 (1.60)	20				UR
	1HX-12168-M1	PAD, ADJUSTING 2 (1.65)	20				UR
	1HX-12168-R1	PAD, ADJUSTING 2 (1.70)	20				UR
	1HX-12168-U1	PAD, ADJUSTING 2 (1.75)	20				UR
	1HX-12168-W1	PAD, ADJUSTING 2 (1.80)	20				UR
	1HX-12168-Y1	PAD, ADJUSTING 2 (1.85)	20				UR

B4

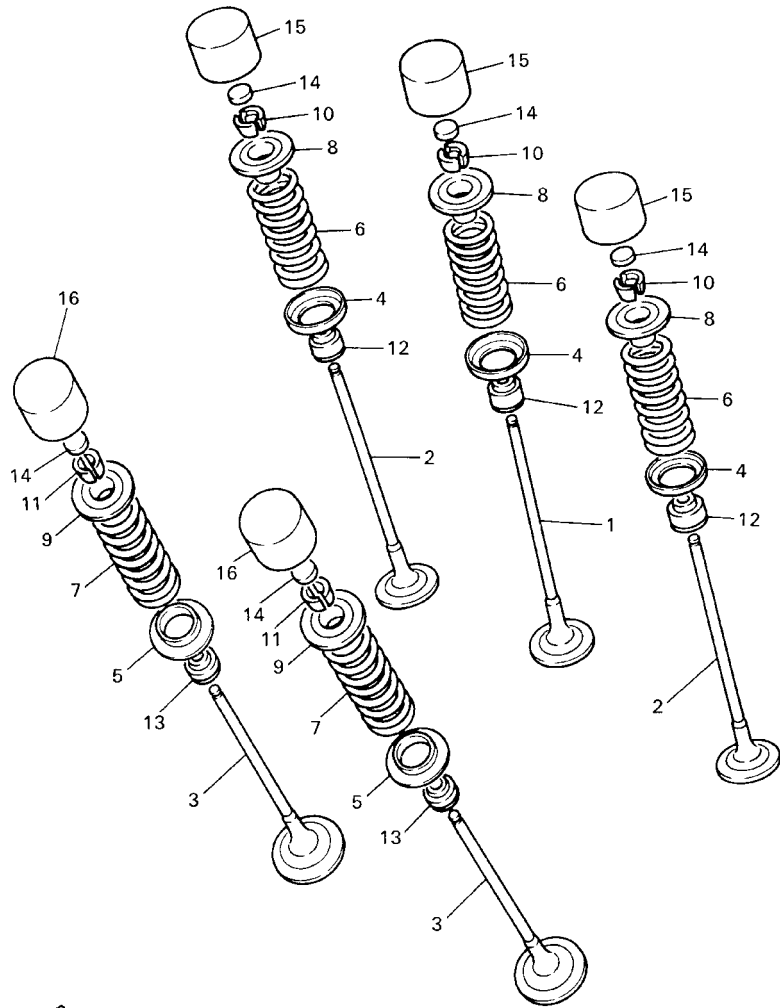

4XV352-8030

FIG. 3 VALVE

REF. NO.	PART NO.	DESCRIPTION	5PW7				REMARKS
14	1HX-12169-11	PAD, ADJUSTING 2 (1.90)	20				UR
	1HX-12169-31	PAD, ADJUSTING 2 (1.95)	20				UR
	1HX-12169-50	PAD, ADJUSTING 2 (2.00)	20				UR
	1HX-12169-70	PAD, ADJUSTING 2 (2.05)	20				UR
	1HX-12169-90	PAD, ADJUSTING 2 (2.10)	20				UR
	1HX-12169-E0	PAD, ADJUSTING 2 (2.15)	20				UR
	1HX-12169-G0	PAD, ADJUSTING 2 (2.20)	20				UR
	1HX-12169-J0	PAD, ADJUSTING 2 (2.25)	20				UR
	1HX-12169-L0	PAD, ADJUSTING 2 (2.30)	20				UR
	1HX-12169-N0	PAD, ADJUSTING 2 (2.35)	20				UR
	1HX-12169-T0	PAD, ADJUSTING 2 (2.40)	20				UR
15	3LN-12153-20	LIFTER, VALVE	12				UR BLUE
	3LN-12153-09	LIFTER, VALVE (O/S)	12				UR GREEN
16	3FV-12153-20	LIFTER, VALVE	8				UR BLUE
	3FV-12153-30	LIFTER, VALVE	8				UR RED
	3FV-12153-09	LIFTER, VALVE (O/S)	8				UR GREEN

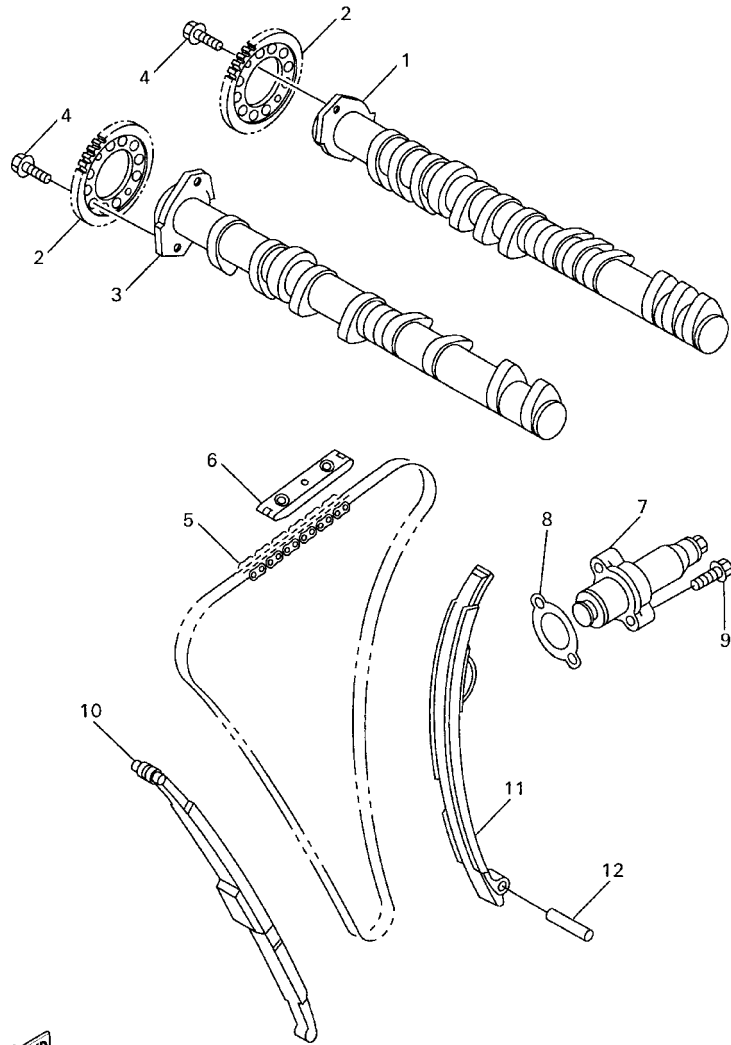

4XV352-8040

FIG. 4 CAMSHAFT. CHAIN

REF. NO.	PART NO.	DESCRIPTION	5PW7				REMARKS
1	5JJ-12171-00	CAMSHAFT 1	1				
2	4XV-12176-00	SPROCKET, CAM CHAIN	2				
3	5PW-12181-00	CAMSHAFT 2	1				
4	90105-07342	BOLT, FLANGE	4				
5	94591-49130	CHAIN	1				
6	5BE-12241-00	GUIDE, STOPPER 2	1				
7	5PW-12210-00	TENSIONER ASSY, CAM CHAIN	1				
8	4FM-12213-00	GASKET, TENSIONER CASE	1				
9	95027-06025	BOLT, FLANGE	2				
10	4XV-12251-00	DAMPER, CHAIN 1	1				
11	5PW-12252-00	DAMPER, CHAIN 2	1				
12	93607-44190	PIN, DOWEL	1				

FIG. 5 WATER PUMP

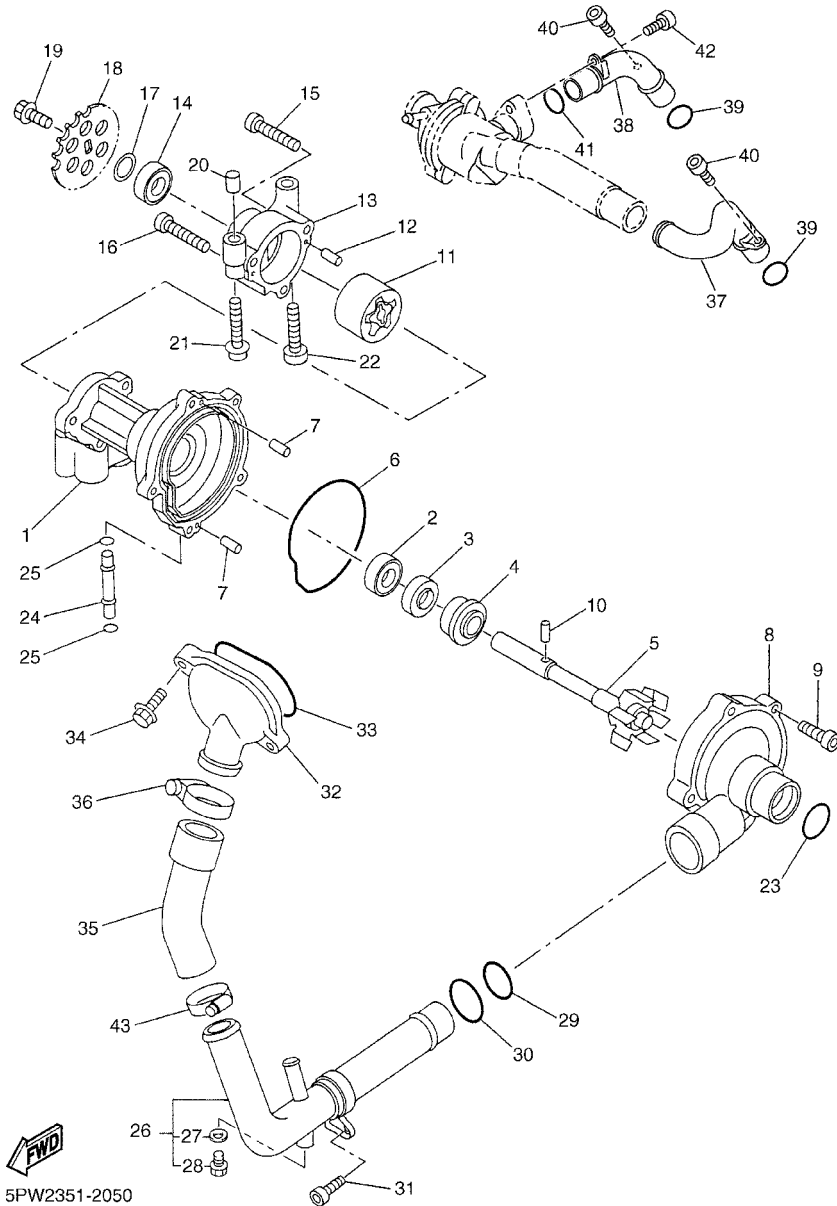

5PW2351-2050

REF. NO.	PART NO.	DESCRIPTION	5PW7				REMARKS
1	4XV-12421-00	HOUSING, WATER PUMP	1				
2	93306-00106	BEARING	1				
3	93102-12372	OIL SEAL	1				
4	11H-12438-10	SEAL, MECHANICAL	1				
5	4XV-12450-00	IMPELLER SHAFT ASSY	1				
6	4XV-12439-00	O-RING	1				
7	93604-10011	PIN, DOWEL	2				
8	4XV-12422-00	COVER, HOUSING	1				
9	91317-06025	BOLT	5				
10	93603-17070	PIN, DOWEL	1				
11	4XV-13310-00	ROTOR ASSY 1	1				
12	93603-12007	PIN, DOWEL	2				
13	4XV-13336-00	HOUSING, ROTOR	1				
14	93306-00106	BEARING	1				
15	91317-06035	BOLT	2				
16	91317-06040	BOLT	1				
17	90201-12541	WASHER, PLATE	1				
18	4XV-13355-00	SPROCKET, DRIVEN	1				
19	90105-06154	BOLT, FLANGE	1				
20	91808-30031	PIN, DOWEL	1				
21	90110-06026	BOLT, HEXAGON SOCKET HEAD	1				
22	90110-06063	BOLT, HEXAGON SOCKET HEAD	1				
23	93210-357A2	O-RING	1				
24	4XV-12485-00	PIPE 5	1				
25	93210-06667	O-RING	2				
26	5PW-12481-00	PIPE 1	1				
27	90430-06014	.GASKET	1				

FIG. 5 WATER PUMP

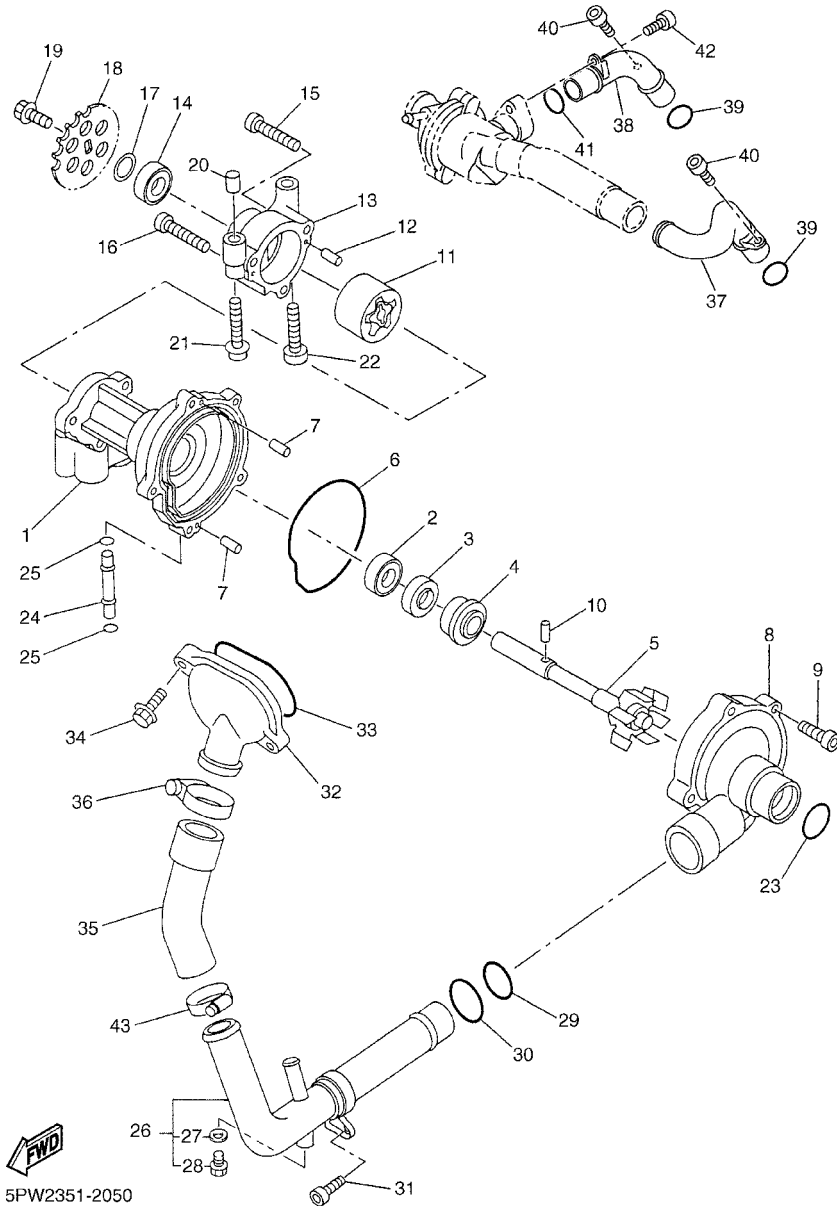

5PW2351-2050

REF. NO.	PART NO.	DESCRIPTION	5PW7				REMARKS
28	90153-06029	.SCREW, HEXAGON	1				
29	93210-235A1	O-RING	1				
30	93210-27370	O-RING	1				
31	90110-06018	BOLT, HEXAGON SOCKET HEAD	1				
32	5JJ-12469-00	JOINT 1	1				
33	93210-47675	O-RING	1				
34	95027-06020	BOLT, FLANGE	2				
35	5JJ-12576-00	HOSE 1	1				
36	90450-38040	HOSE CLAMP ASSY	1				
37	5PW-12482-00	PIPE 2	1				
38	5PW-12483-00	PIPE 3	1				
39	93210-18417	O-RING	2				
40	91317-06016	BOLT	2				
41	93210-18417	O-RING	1				
42	91317-06012	BOLT	1				
43	90450-35001	HOSE CLAMP ASSY	1				

FIG. 6 RADIATOR. HOSE

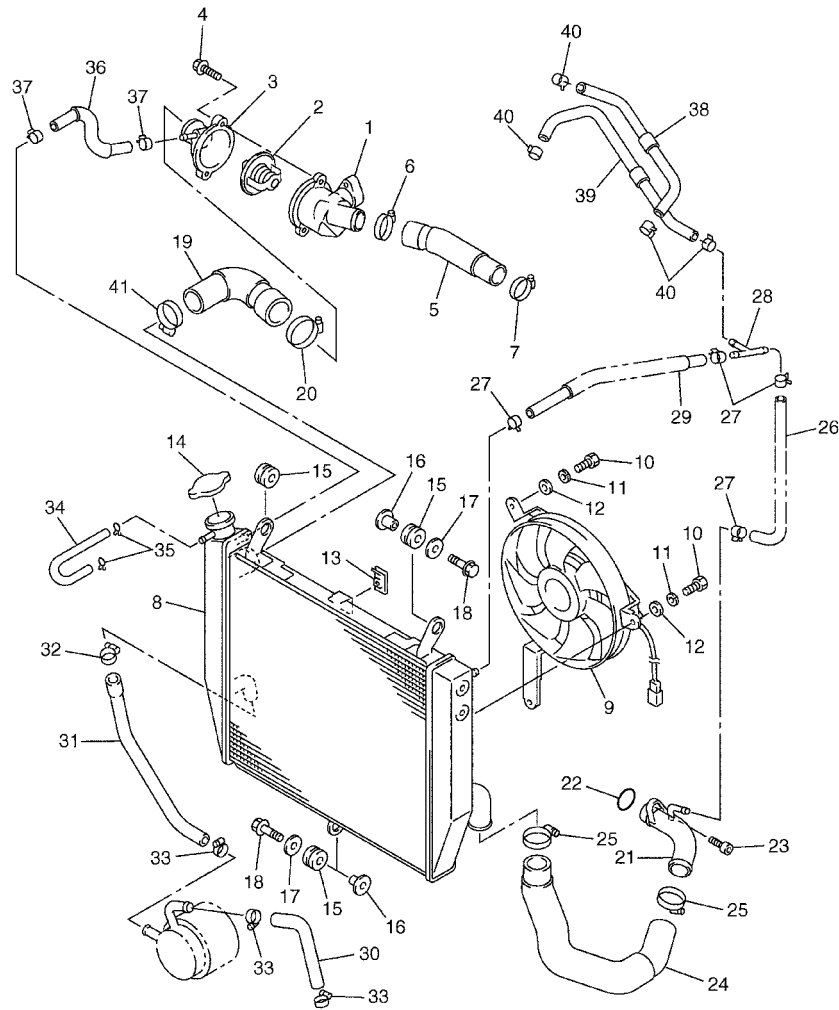

5PW2351-2060

REF. NO.	PART NO.	DESCRIPTION	5PW7				REMARKS
1	5PW-12417-01	HOUSING, THERMOSTAT	1				
2	4FM-12410-00	THERMOSTAT ASSY	1				
3	5PW-12413-00	COVER, THERMOSTAT	1				
4	95027-06025	BOLT, FLANGE	2				
5	5PW-12577-00	HOSE 2	1				
6	90450-32015	HOSE CLAMP ASSY	1				
7	90450-28014	HOSE CLAMP ASSY	1				
8	5PW-12461-00	RADIATOR ASSY	1				
9	5PW-12405-00	BLOWER ASSY	1				
10	97307-06012	BOLT	3				
11	92907-06100	WASHER, SPRING	3				
12	92907-06600	WASHER, PLATE	3				
13	1AA-12535-00	PLATE	2				
14	22W-12462-00	CAP, RADIATOR	1				
15	90480-15363	GROMMET	3				
16	90387-07391	COLLAR	2				
17	90201-06071	WASHER, PLATE	2				
18	95827-06025	BOLT, FLANGE	2				
19	5PW-12579-00	HOSE 4	1				
20	90450-38040	HOSE CLAMP ASSY	1				
21	5PW-12484-00	PIPE 4	1				
22	93210-23787	O-RING	1				
23	90110-06018	BOLT, HEXAGON SOCKET HEAD	1				
24	5PW-12551-00	HOSE 7	1				
25	90450-35001	HOSE CLAMP ASSY	2				
26	5PW-1243A-00	HOSE 1	1				
27	90467-11090	CLIP	4				

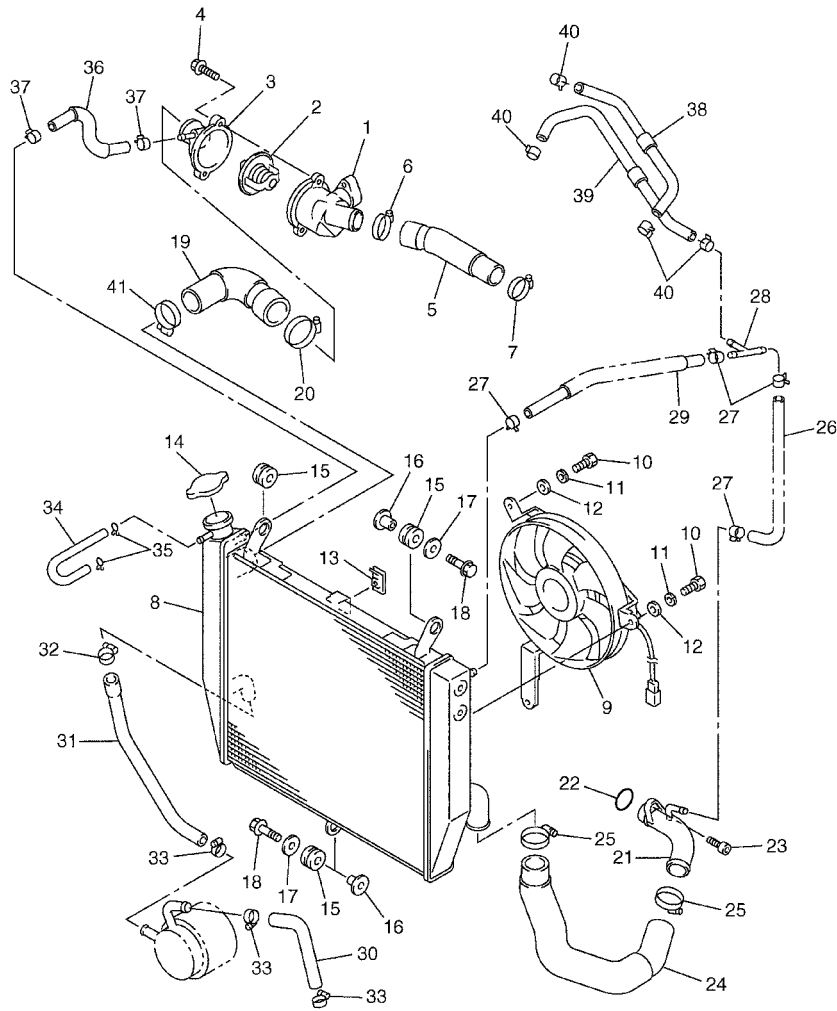



5PW2351-2060

FIG. 6 RADIATOR. HOSE

REF. NO.	PART NO.	DESCRIPTION	5PW7				REMARKS
28	90413-07023	WAY 3	1				
29	5PW-1244G-00	HOSE, 4	1				
30	5PW-12588-00	HOSE 5	1				
31	5PW-12589-00	HOSE 6	1				
32	90450-22017	HOSE CLAMP ASSY	1				
33	90450-19001	HOSE CLAMP ASSY	3				
34	90445-094K7	HOSE (L180)	1				
35	90467-08003	CLIP	2				
36	5PW-12552-00	HOSE 8	1				
37	90467-11090	CLIP	2				
38	5PW-1243E-00	HOSE 2	1				
39	5PW-1243F-00	HOSE,3	1				
40	90467-11090	CLIP	4				
41	90450-35001	HOSE CLAMP ASSY	1				

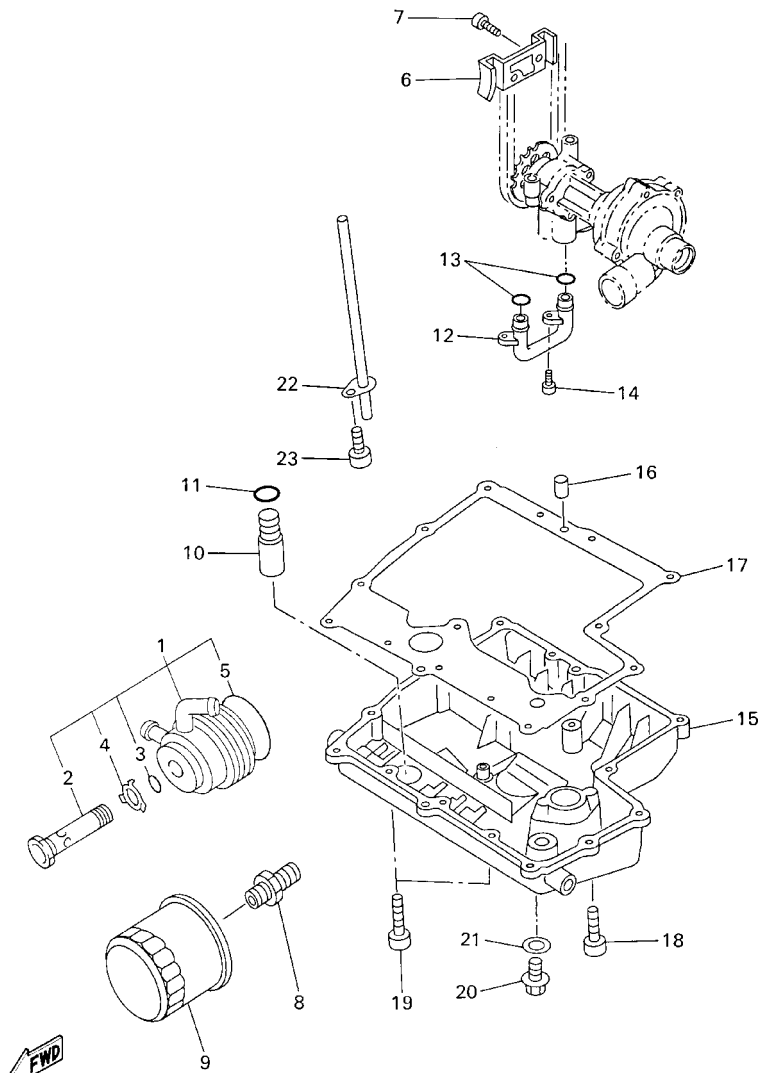
FIG. 8 OIL CLEANER



4XV352-8081

REF. NO.	PART NO.	DESCRIPTION	5PW7				REMARKS
1	5PW-13470-00	OIL COOLER ASSY	1				
2	5PW-12822-00	.BOLT, UNION	1				
3	5PW-13473-00	.O-RING	1				
4	5PW-13318-00	.WASHER	1				
5	5PW-13475-00	.GASKET	1				
6	4XV-13898-00	HOLDER	1				
7	91317-06012	BOLT	2				
8	90401-20145	BOLT, UNION	1				
9	5GH-13440-00	ELEMENT ASSY, OIL CLEANER	1				
10	5PW-13490-00	RELIEF VALVE ASSY	1				
11	93210-15566	O-RING	1				
12	4XV-13416-00	PIPE, OIL 1	1				
13	93210-14003	O-RING	2				
14	91317-06012	BOLT	2				
15	5PW-13417-00	COVER, STRAINER	1				
16	99530-08012	PIN, DOWEL	2				
17	5LV-13414-00	GASKET, STRAINER COVER	1				
18	91317-06025	BOLT	13				
19	90110-06225	BOLT, HEXAGON SOCKET HEAD	2				
20	90340-14132	PLUG, STRAIGHT SCREW	1				
21	214-11198-01	GASKET	1				
22	5PW-13161-00	PIPE, DELIVERY 1	1				
23	90110-06018	BOLT, HEXAGON SOCKET HEAD	1				

FIG. 9 INTAKE

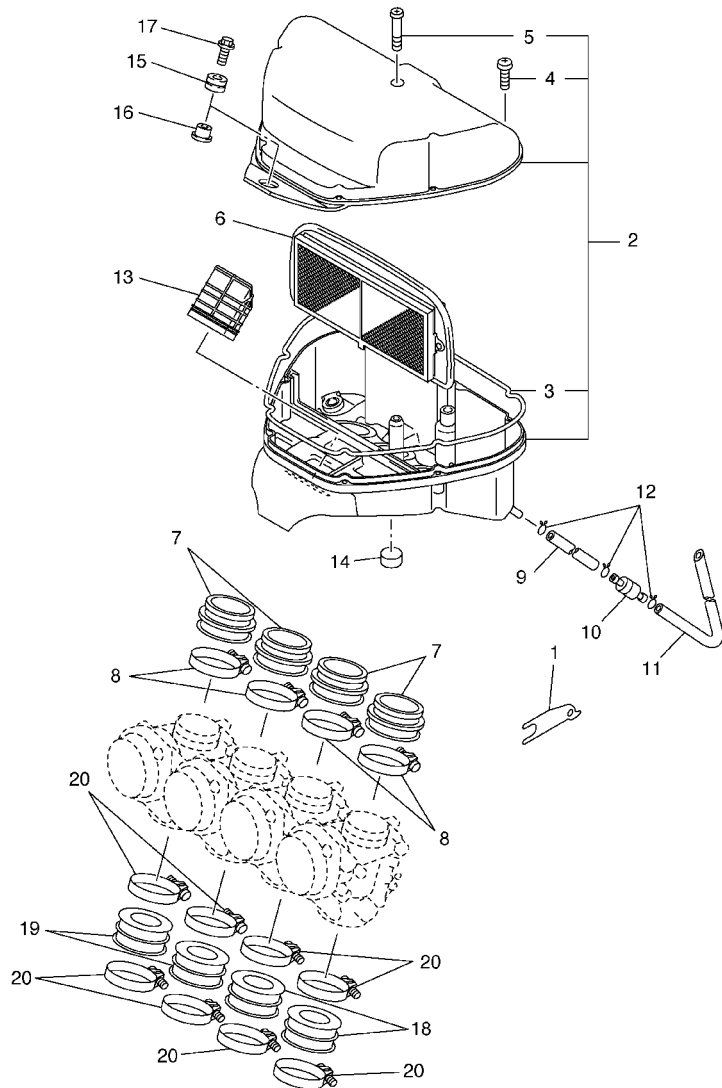

REF. NO.	PART NO.	DESCRIPTION	5PW7				REMARKS
1	5JJ-14414-00	STAY 2	1				
2	5PW-14401-00	AIR CLEANER CASE ASSY	1				
3	4XV-14452-00	.SEAL	1				
4	98507-05025	.SCREW, PAN HEAD	7				
5	98507-05045	.SCREW, PAN HEAD	1				
6	5PW-14451-00	ELEMENT, AIR CLEANER	1				
7	5PW-14453-00	JOINT, AIR CLEANER 1	4				
8	90450-53002	HOSE CLAMP ASSY	4				
9	90445-11M52	HOSE (L150)	1				
10	4X7-2149Y-00	FILTER ASSY	1				
11	90445-11013	HOSE (L410)	1				
12	90467-10041	CLIP	3				
13	5PW-14437-00	DUCT	1				
14	4XV-28371-00	DAMPER	1				
15	90480-12314	GROMMET	1				
16	90387-065J6	COLLAR	1				
17	95817-06020	BOLT, FLANGE	1				
18	5PW-13597-00	JOINT, CARBURETOR 3	2				
19	5PW-13598-00	JOINT, CARBURETOR 4	2				
20	90450-63001	HOSE CLAMP ASSY	8				



5PW1300-2090

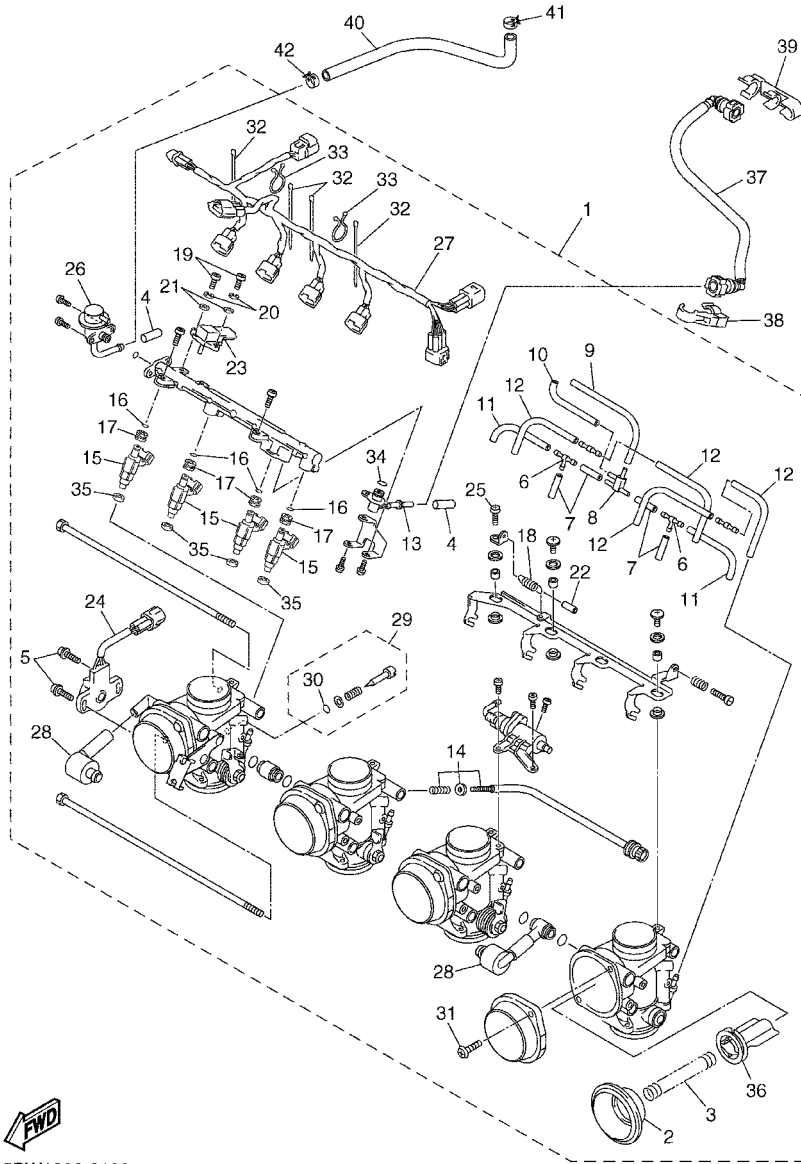

5PW1300-2100

FIG. 10 INTAKE 2

REF. NO.	PART NO.	DESCRIPTION	5PW7				REMARKS
1	5PW-13750-00	THROTTLE BODY ASSY	1				
2	5PW-24411-00	.DIAPHRAGM	4				
3	4KM-14933-00	.SPRING, DIAPHRAGM	4				
4	5JW-14118-00	.CAP	2				
5	8CC-14216-10	.SCREW	2				
6	68V-24376-00	.PIPE, JOINT 1	2				
7	5FL-14348-10	.PIPE 1	4				
8	5PW-1410F-00	.CONNECTOR	1				
9	5PW-14348-00	.PIPE 1	1				
10	5PW-14349-00	.PIPE	1				
11	5FL-14348-00	.PIPE 1	2				
12	5PW-14396-00	.PIPE	4				
13	5JW-12881-00	.PIPE,FUEL INJECTION 1	1				
14	5PW-14103-00	.THROTTLE SCREW SET	1				
15	5PW-13761-00	.INJECTOR ASSY	4				
16	5FL-14147-00	.O-RING	4				
17	5FL-13766-00	.RUBBER, INJECTOR	4				
18	5JW-14589-00	.SPRING	1				
19	98506-05016	.SCREW, PAN HEAD	2				
20	92906-05100	.WASHER, SPRING	2				
21	92906-05600	.WASHER, PLATE	2				
22	5DM-14936-00	.SEAT, SPRING	1				
23	5JW-82380-00	.SENSOR, PRESSURE	1				
24	5PW-85885-00	.THROTTLE SENSOR ASSY	1				
25	98502-04010	.SCREW, PAN HEAD	1				
26	5PW-13906-00	.REGULATOR, PRESSURE	1				
27	5PW-82386-00	.EXTENSION, WIRE HARNESS	1				

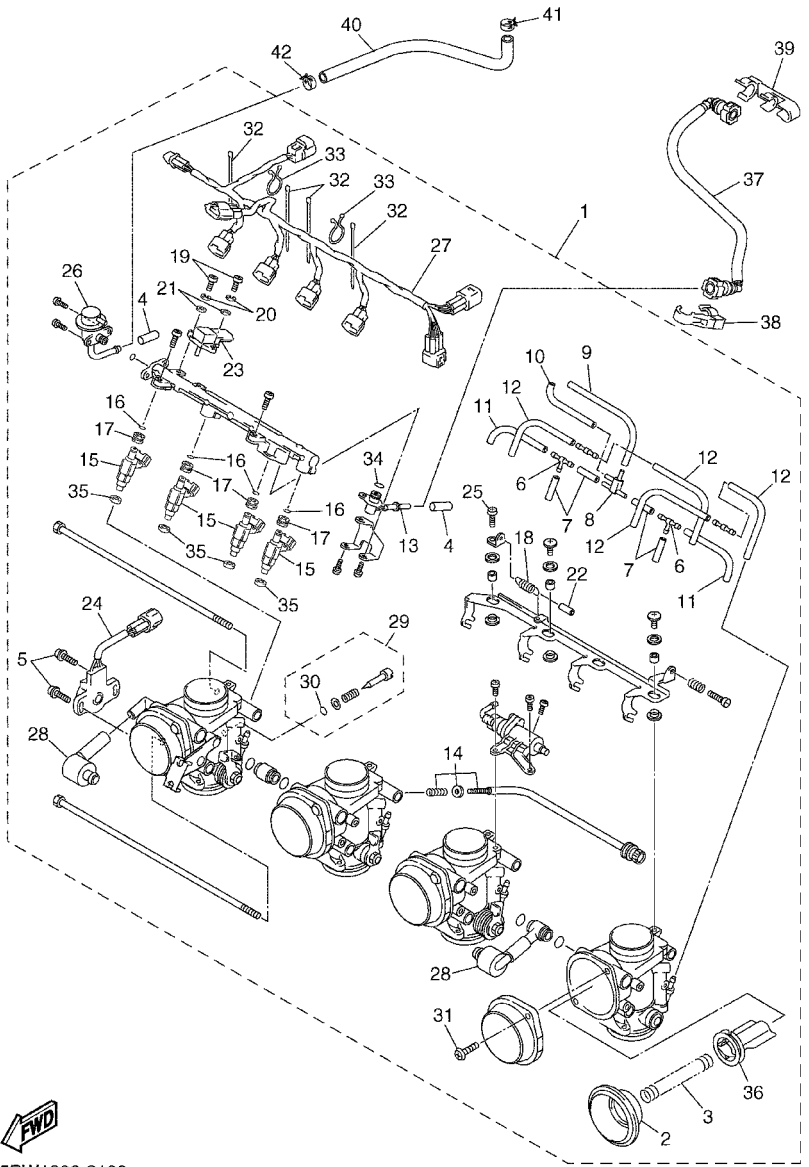

5PW1300-2100

FIG. 10 INTAKE 2

REF. NO.	PART NO.	DESCRIPTION	5PW7				REMARKS
28	3LN-24515-00	.NET, FILTER 2	2				
29	5JW-14104-00	.AIR SCREW SET	4				
30	3H1-14147-00	..O-RING	1				
31	4KM-14216-00	.SCREW	8				
32	4KM-14137-00	.CLIP	4				
33	5PW-14137-00	.CLIP	2				
34	5JW-14147-00	.O-RING	1				
35	90430-09002	.GASKET	4				
36	5PW-14112-00	.VALVE, THROTTLE 1	4				
37	5PW-13971-00	PIPE, FUEL 1	1				
38	90464-16007	CLAMP	1				
39	90464-16005	CLAMP	1				
40	5PW-13972-00	PIPE, FUEL 2	1				
41	90467-12003	CLIP	1				
42	90467-120A1	CLIP	1				

FIG. 11 AIR INDUCTION SYSTEM

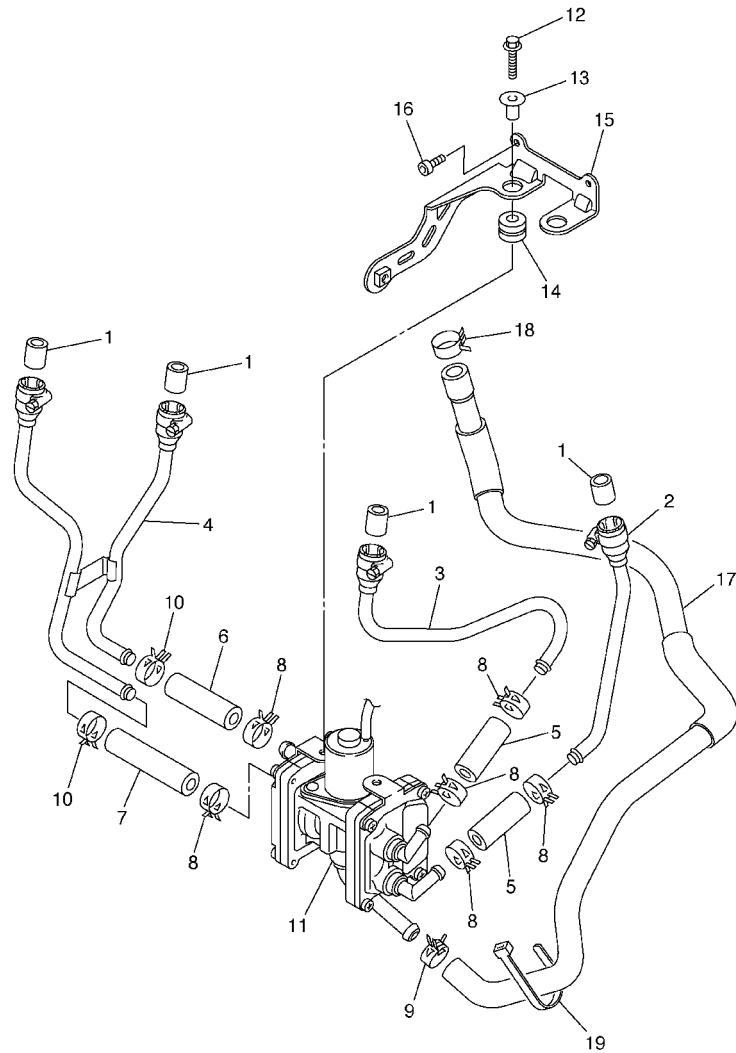

REF. NO.	PART NO.	DESCRIPTION	5PW7				REMARKS
1	4KM-14714-01	GASKET, MUFFLER	4				
2	5JJ-14872-00	PIPE 2	1				
3	5PW-14873-00	PIPE 3	1				
4	5JJ-14874-00	PIPE 4	1				
5	5JJ-14882-00	HOSE, BEND 2	2				
6	5JJ-14883-00	HOSE, BEND 3	1				
7	5JJ-14886-00	HOSE, BEND 6	1				
8	90467-15054	CLIP	6				
9	90467-16181	CLIP	1				
10	90467-15001	CLIP	2				
11	5PW-14803-00	AIR INDUCTION SYSTEM ASSY	1				
12	95827-06020	BOLT, FLANGE	2				
13	90387-07391	COLLAR	2				
14	90480-15316	GROMMET	2				
15	5PW-14868-00	BRACKET 2	1				
16	91317-06012	BOLT	2				
17	5PW-14881-00	HOSE, BEND 1	1				
18	90467-17089	CLIP	1				
19	90464-13077	CLAMP	1				



5PW1300-2110

FIG. 12 EXHAUST

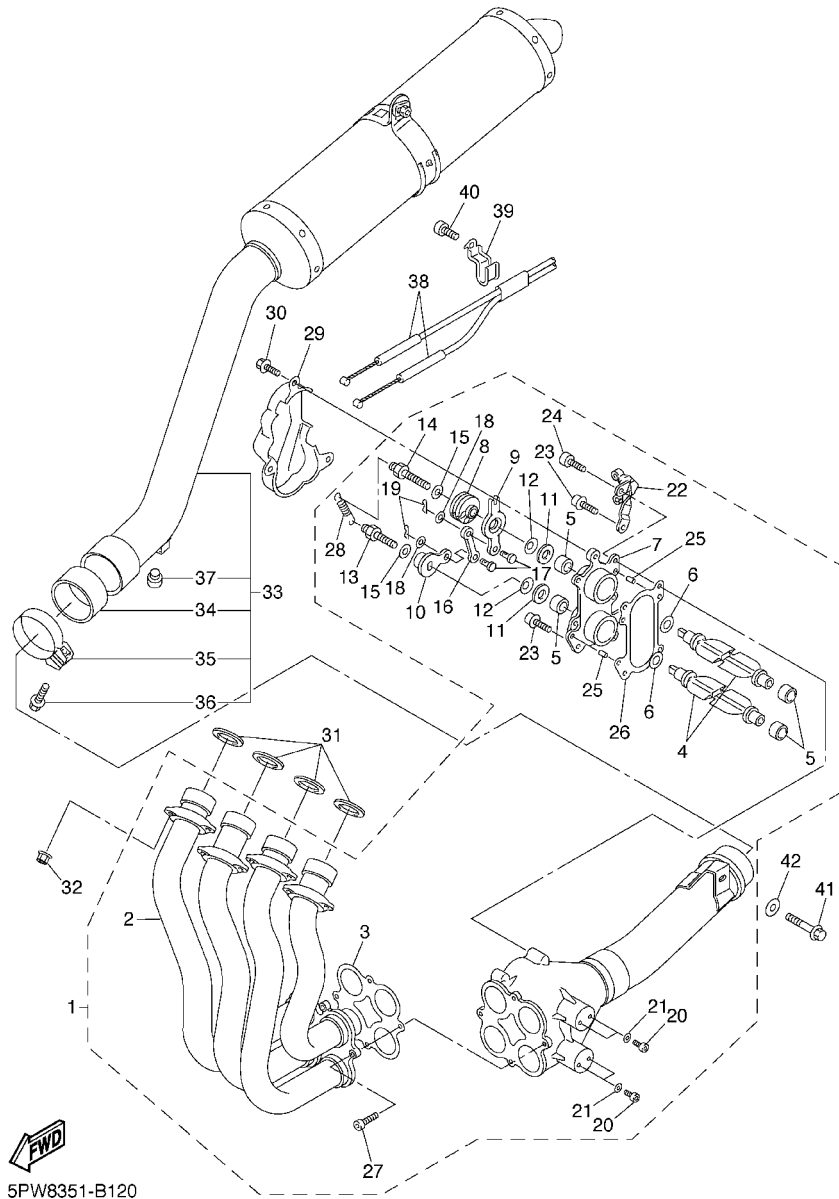

5PW8351-B120

REF. NO.	PART NO.	DESCRIPTION	5PW7				REMARKS
1	5PW-14610-01	EXHAUST PIPE ASSY 1	1				
2	5PW-14602-01	.EXHAUST PIPE COMP.	1				
3	5PW-14623-00	.GASKET, EXHAUST PIPE	1				
4	5PW-14821-00	.ARM, SHAFT (VALVE)	2				
5	5PW-14638-01	.COLLAR	4				
6	90201-14014	.WASHER, PLATE	2				
7	5PW-14811-01	.HOUSING	1				
8	5PW-14865-00	.PULLEY	1				
9	5PW-14889-00	.CAP, CASE	1				
10	5PW-14858-00	.CAP, CASE	1				
11	90201-10M76	.WASHER, PLATE	2				
12	5PW-14683-00	.SPRING, HOOK	2				
13	5PW-14684-00	.BOLT, HOOK	1				
14	5PW-14777-00	.BOLT	1				
15	90201-050T4	.WASHER, PLATE	2				
16	5PW-14836-00	.ROD	1				
17	5PW-1469V-00	.PIN	2				
18	90201-06431	.WASHER, PLATE	2				
19	93410-06053	.CIRCLIP	2				
20	91380-04006	.BOLT	4				
21	92990-04600	.WASHER, PLATE	4				
22	5PW-14867-00	.BRACKET	1				
23	90119-06115	.BOLT, WITH WASHER	4				
24	90110-06025	.BOLT, HEXAGON SOCKET HEAD	1				
25	93606-07M17	.PIN, DOWEL	2				
26	5PW-14643-00	.GASKET 3	1				
27	90110-06025	.BOLT, HEXAGON SOCKET HEAD	4				

FIG. 12 EXHAUST

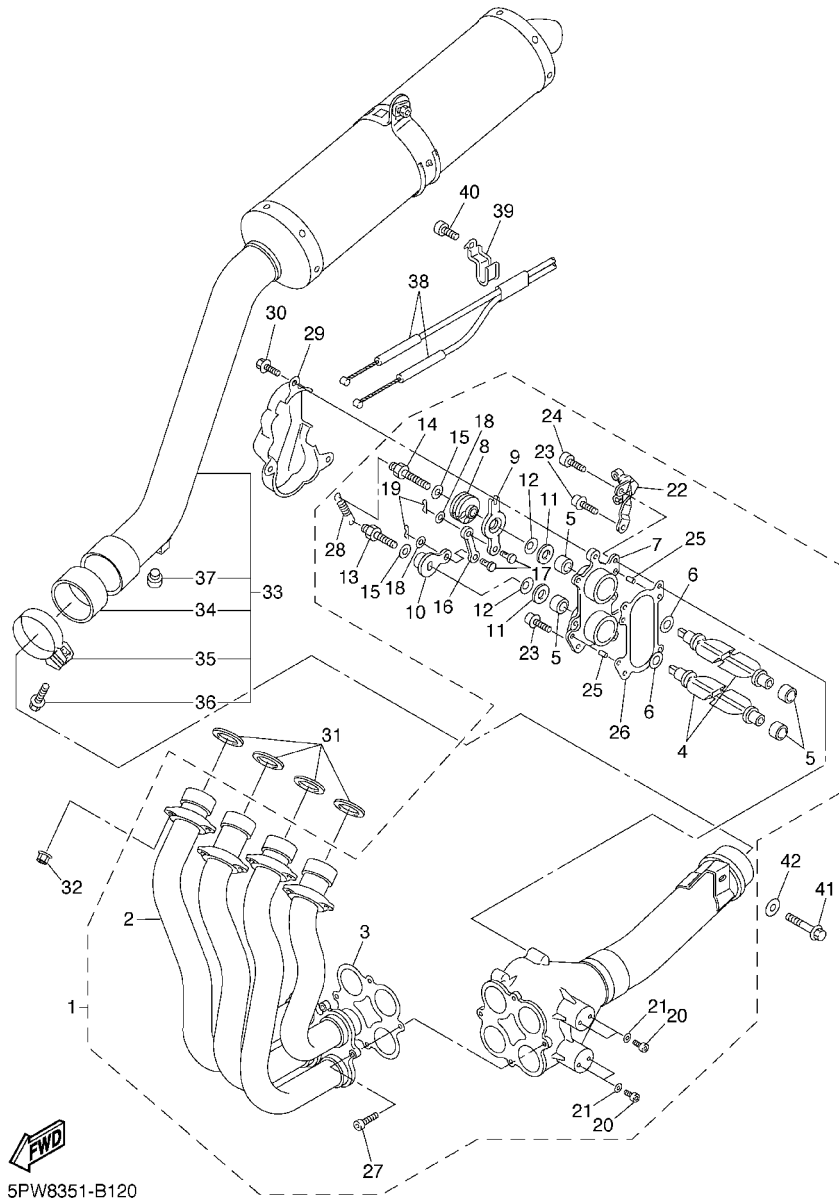

5PW8351-B120

REF. NO.	PART NO.	DESCRIPTION	5PW7				REMARKS
28	90506-10003	.SPRING, TENSION	1				
29	5PW-14826-00	PROTECTOR, EXHAUST	1				
30	90119-06187	BOLT, WITH WASHER	3				
31	4FM-14613-00	GASKET, EXHAUST PIPE	4				
32	90179-08410	NUT	8				
33	5PW-14710-00	MUFFLER ASSY 1	1				
34	4XV-14714-00	.GASKET, MUFFLER	1				
35	5JJ-14715-00	.BAND, MUFFLER	1				
36	95817-08030	.BOLT, FLANGE	1				
37	4FM-24181-00	.DAMPER, LOCATING 1	1				
38	5PW-1130E-00	CABLE PULLEY ASSY	1				
39	90462-10013	CLAMP	1				
40	91314-06010	BOLT	1				
41	95817-08040	BOLT, FLANGE	1				
42	90201-08612	WASHER, PLATE	1				

FIG. 13 CRANKCASE

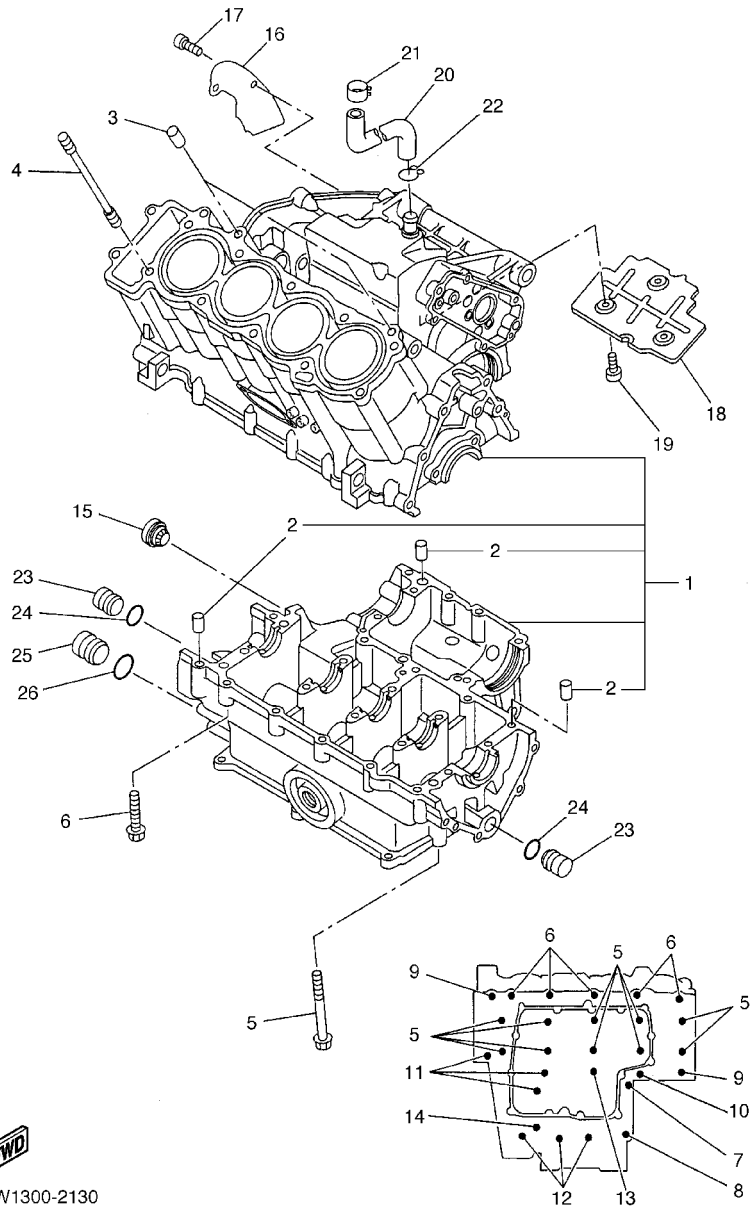

REF. NO.	PART NO.	DESCRIPTION	5PW7				REMARKS
1	5PW-15100-00	CRANKCASE ASSY	1				
2	99530-10014	.PIN, DOWEL	3				
3	99530-10114	PIN, DOWEL	2				
4	90116-10619	BOLT, STUD	10				
5	90119-09002	BOLT, WITH WASHER	10				
6	95817-06055	BOLT, FLANGE	5				
7	90105-08015	BOLT, FLANGE	1				
8	95817-08050	BOLT, FLANGE	1				
9	90109-065G3	BOLT	2				
10	95817-06060	BOLT, FLANGE	1				
11	95817-06070	BOLT, FLANGE	3				
12	95817-06045	BOLT, FLANGE	3				
13	95814-06050	BOLT, FLANGE	1				
14	95817-06065	BOLT, FLANGE	1				
15	5PW-15361-00	GAUGE, LEVEL	1				
16	4XV-11165-00	PLATE, BREATHER	1				
17	90110-06018	BOLT, HEXAGON SOCKET HEAD	2				
18	4XV-11145-00	PLATE, BREATHER 2	1				
19	90110-06018	BOLT, HEXAGON SOCKET HEAD	3				
20	90445-161K7	HOSE (L215)	1				
21	90468-08104	CLIP	1				
22	90467-14015	CLIP	1				
23	90338-16262	PLUG	2				
24	93210-12790	O-RING	2				
25	90338-20263	PLUG	1				
26	93210-16314	O-RING	1				

 5PW1300-2130

FIG. 14 CRANKCASE COVER 1

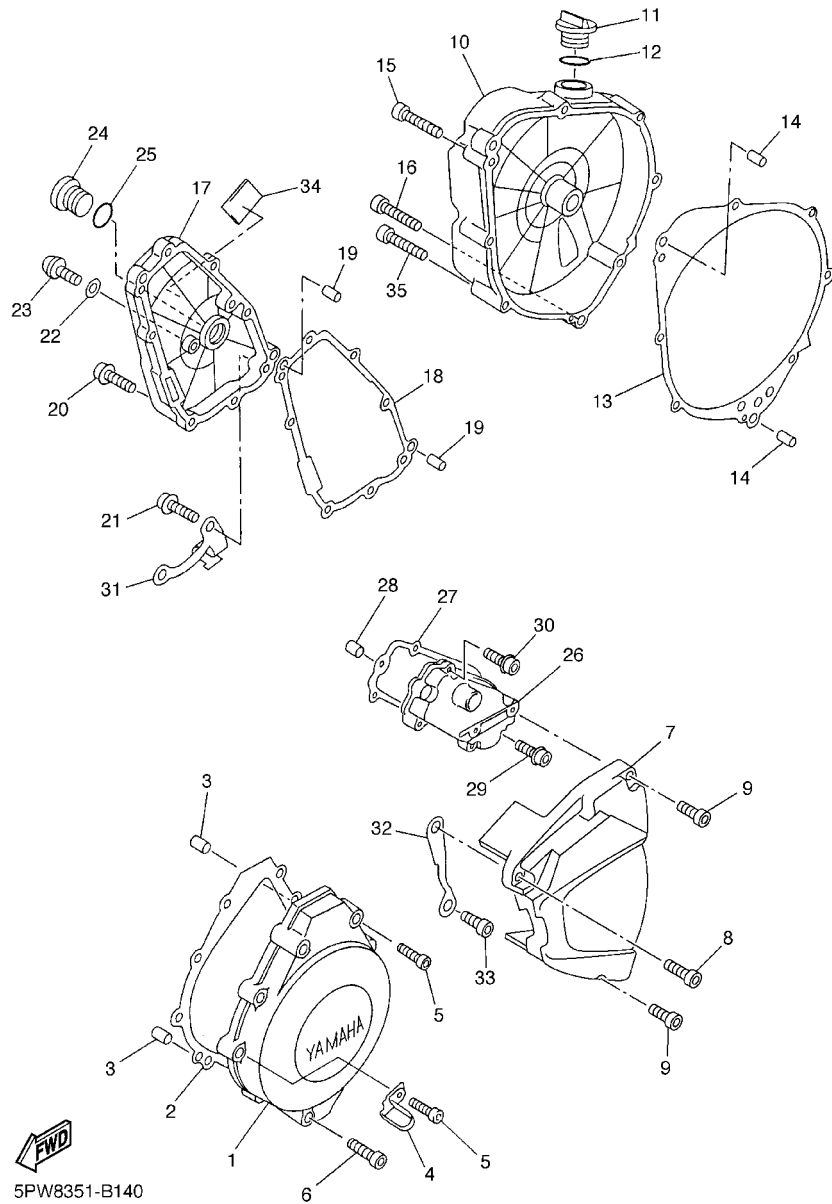

REF. NO.	PART NO.	DESCRIPTION	5PW7				REMARKS
1	5PW-15411-00	COVER, CRANKCASE 1	1				
2	5PW-15451-00	GASKET, CRANKCASE COVER 1	1				
3	99530-08012	PIN, DOWEL	2				
4	90461-10003	CLAMP	1				
5	91314-06035	BOLT	8				
6	91314-06020	BOLT	1				
7	5PW-15418-00	COVER, CHAIN CASE	1				
8	90110-06224	BOLT, HEXAGON SOCKET HEAD	1				
9	91314-06025	BOLT	2				
10	5PW-15421-01	COVER, CRANKCASE 2	1				
11	3F9-15362-00	PLUG, OIL LEVEL	1				
12	93210-27194	O-RING	1				
13	5PW-15461-00	GASKET, CRANKCASE COVER 2	1				
14	93608-21002	PIN, DOWEL	2				
15	91314-06040	BOLT	5				
16	91314-06050	BOLT	2				
17	5PW-15416-00	COVER, OIL PUMP	1				
18	5JJ-15456-00	GASKET, OIL PUMP COVER 1	1				
19	99530-08012	PIN, DOWEL	2				
20	90109-06014	BOLT	4				
21	90109-06015	BOLT	4				
22	90430-08143	GASKET	1				
23	92014-08016	BOLT, BUTTON HEAD	1				
24	90340-32080	PLUG, STRAIGHT SCREW	1				
25	93210-32172	O-RING	1				
26	5PW-15425-00	COVER, GENERATOR 2	1				
27	5JJ-15463-00	GASKET, COVER 2	1				

FIG. 14 CRANKCASE COVER 1

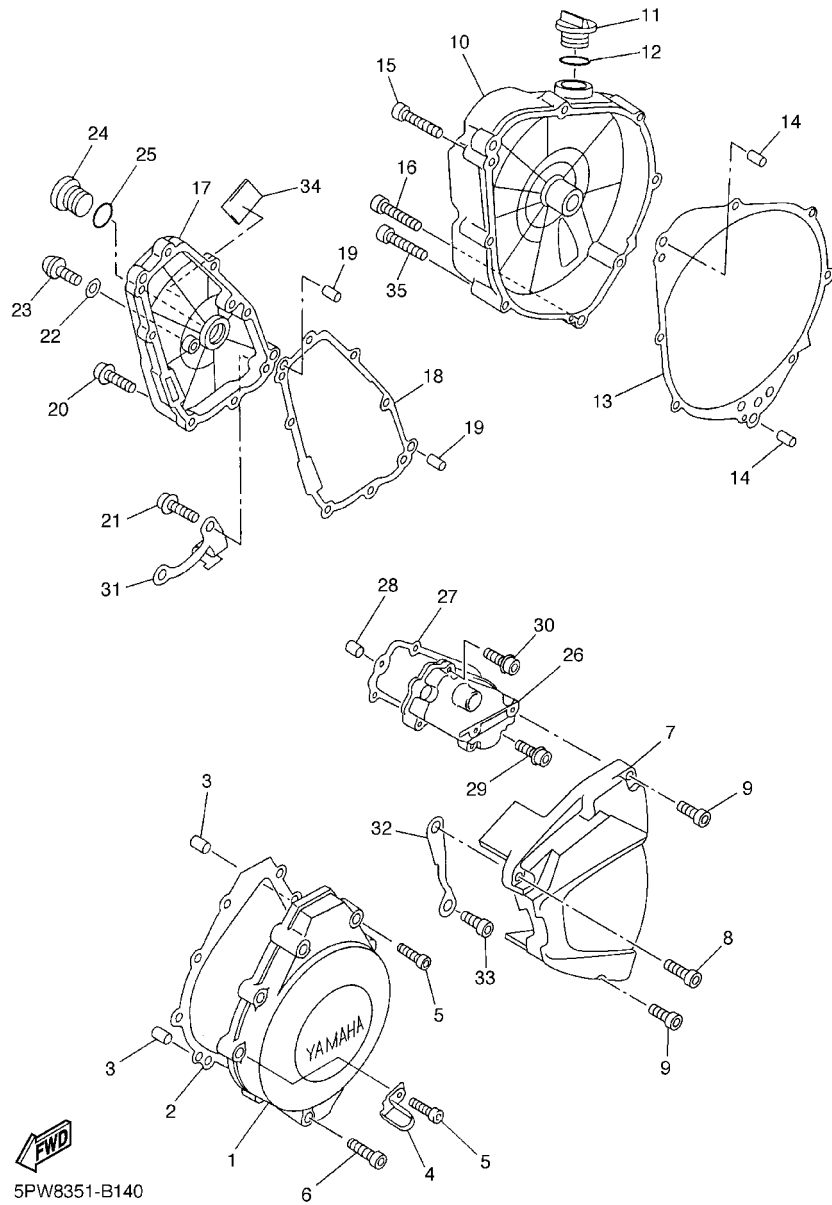

5PW8351-B140

REF. NO.	PART NO.	DESCRIPTION	5PW7				REMARKS
28	99530-08012	PIN, DOWEL	2				
29	90109-06014	BOLT	2				
30	90109-06015	BOLT	3				
31	4XV-15441-00	HOLDER, CLUTCH CABLE	1				
32	4XV-15113-00	PLATE	1				
33	90110-06136	BOLT, HEXAGON SOCKET HEAD	1				
34	5JW-2139X-00	DAMPER	1				
35	90110-06080	BOLT, HEXAGON SOCKET HEAD	1				

FIG. 15 STARTER

REF. NO.	PART NO.	DESCRIPTION	5PW7				REMARKS
1	5PW-15515-00	GEAR 3	1				
2	93310-338S6	BEARING	1				
3	5JJ-15517-00	GEAR, IDLER 2	1				
4	4XV-15521-00	SHAFT 1	1				
5	93410-08072	CIRCLIP	1				
6	90201-08089	WASHER, PLATE	1				
7	92017-06014	BOLT	1				
8	90430-06014	GASKET	1				
9	4XV-15570-00	STARTER CLUTCH ASSY	1				
10	90110-06065	BOLT, HEXAGON SOCKET HEAD	3				

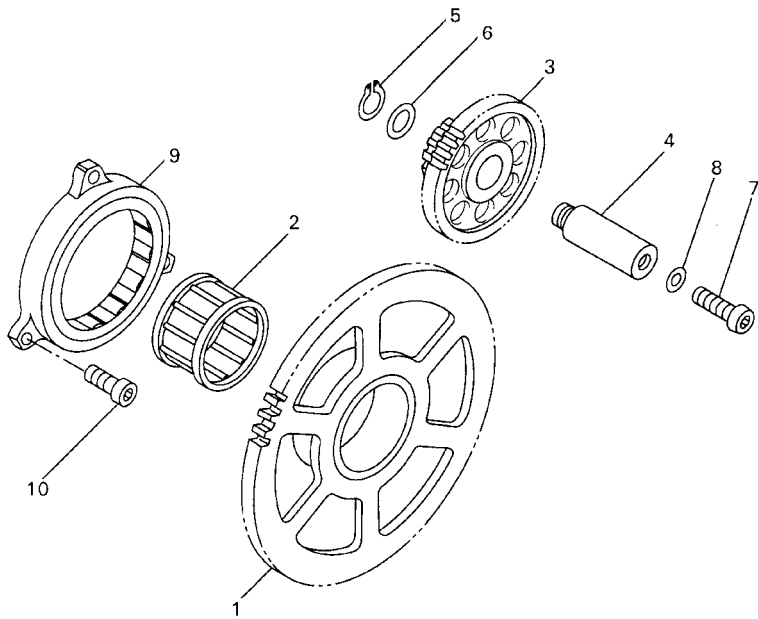

5JJ1300-0150

FIG. 16 CLUTCH

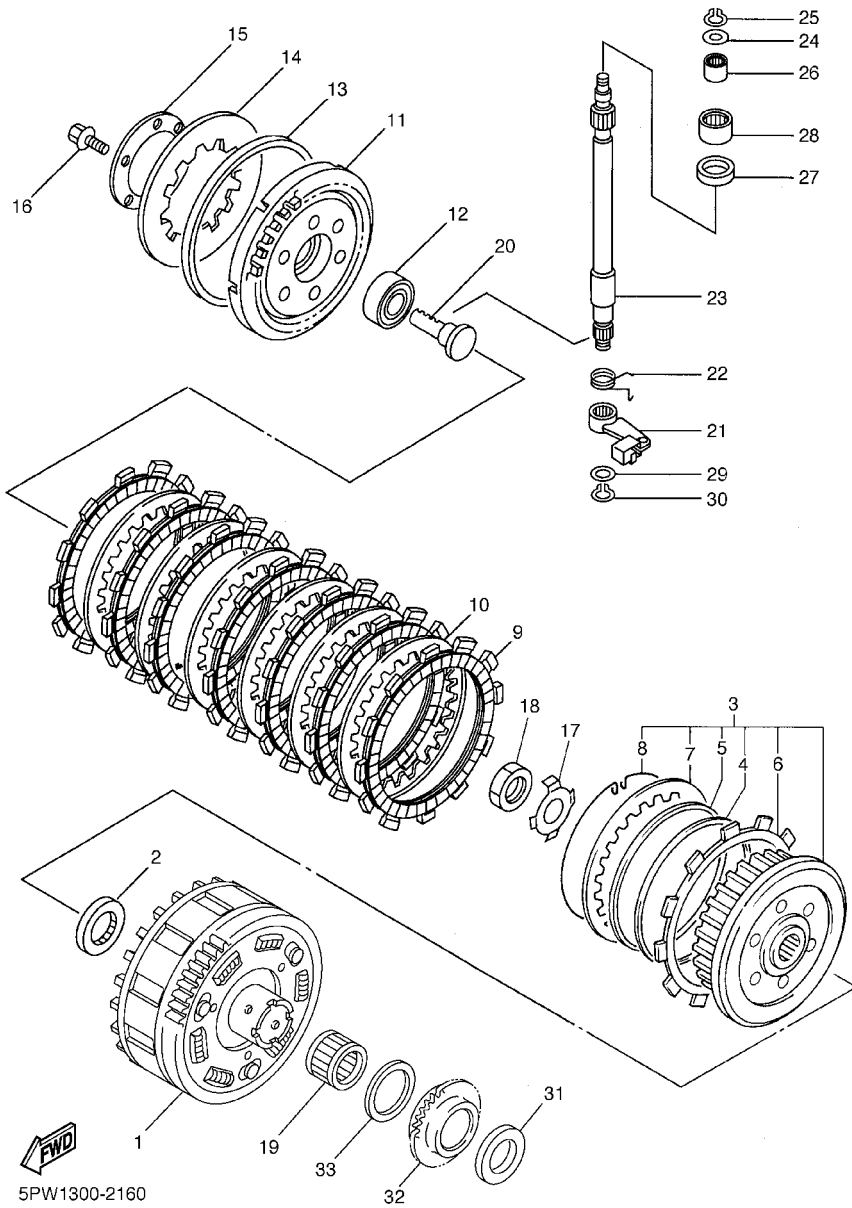

REF. NO.	PART NO.	DESCRIPTION	5PW7				REMARKS
1	5PW-16150-00	PRIMARY DRIVEN GEAR COMP.	1				
2	26H-16154-00	PLATE, THRUST 1	1				
3	4XV-16370-00	CLUTCH BOSS ASSY	1				
4	4XV-16384-00	.PLATE, SEAT	1				
5	36Y-16383-00	.SPRING, CLUTCH BOSS	1				
6	4XV-16331-00	.PLATE, FRICTION 2	1				
7	2H7-16325-00	.PLATE, CLUTCH 2	1				
8	2H7-16385-00	.RING, CLUTCH BOSS	1				
9	341-16321-13	PLATE, FRICTION	7				
10	2H7-16325-00	PLATE, CLUTCH 2	6				
11	4XV-16351-00	PLATE, PRESSURE 1	1				
12	93306-00304	BEARING (B6003C4)	1				
13	36Y-16335-00	HOUSING, SPRING	1				
14	36Y-16334-00	SPRING, CLUTCH 2	1				
15	1TX-16352-00	PLATE, PRESSURE 2	1				
16	95817-06025	BOLT, FLANGE	6				
17	90215-23001	WASHER, LOCK	1				
18	90179-20004	NUT	1				
19	93310-228S5	BEARING	1				
20	4XV-16356-01	ROD, PUSH 1	1				
21	4XV-16340-10	PUSH LEVER ASSY	1				
22	90508-164B2	SPRING, TORSION	1				
23	4XV-16382-00	AXLE, PUSH LEVER	1				
24	92907-08600	WASHER, PLATE	1				
25	99001-07600	CIRCLIP	1				
26	93317-11020	BEARING	1				
27	93102-15212	OIL SEAL	1				

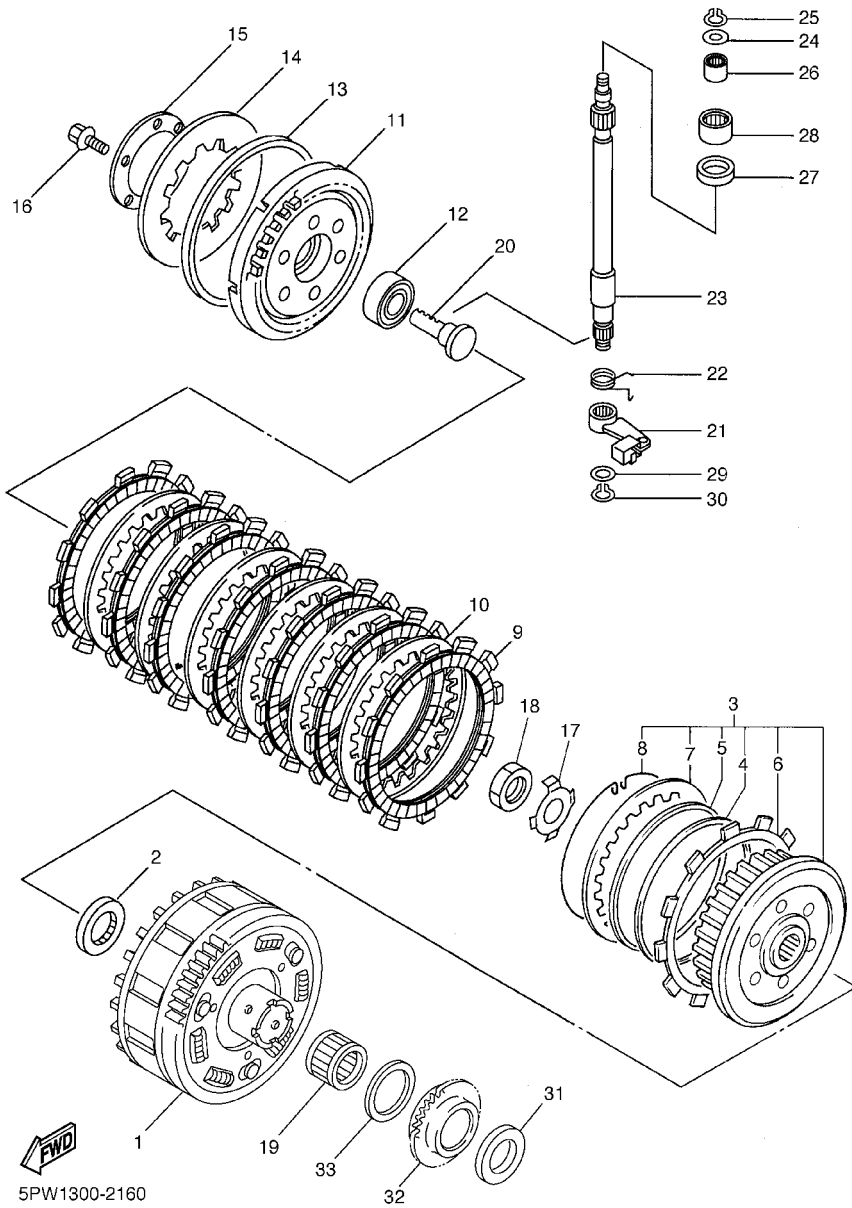
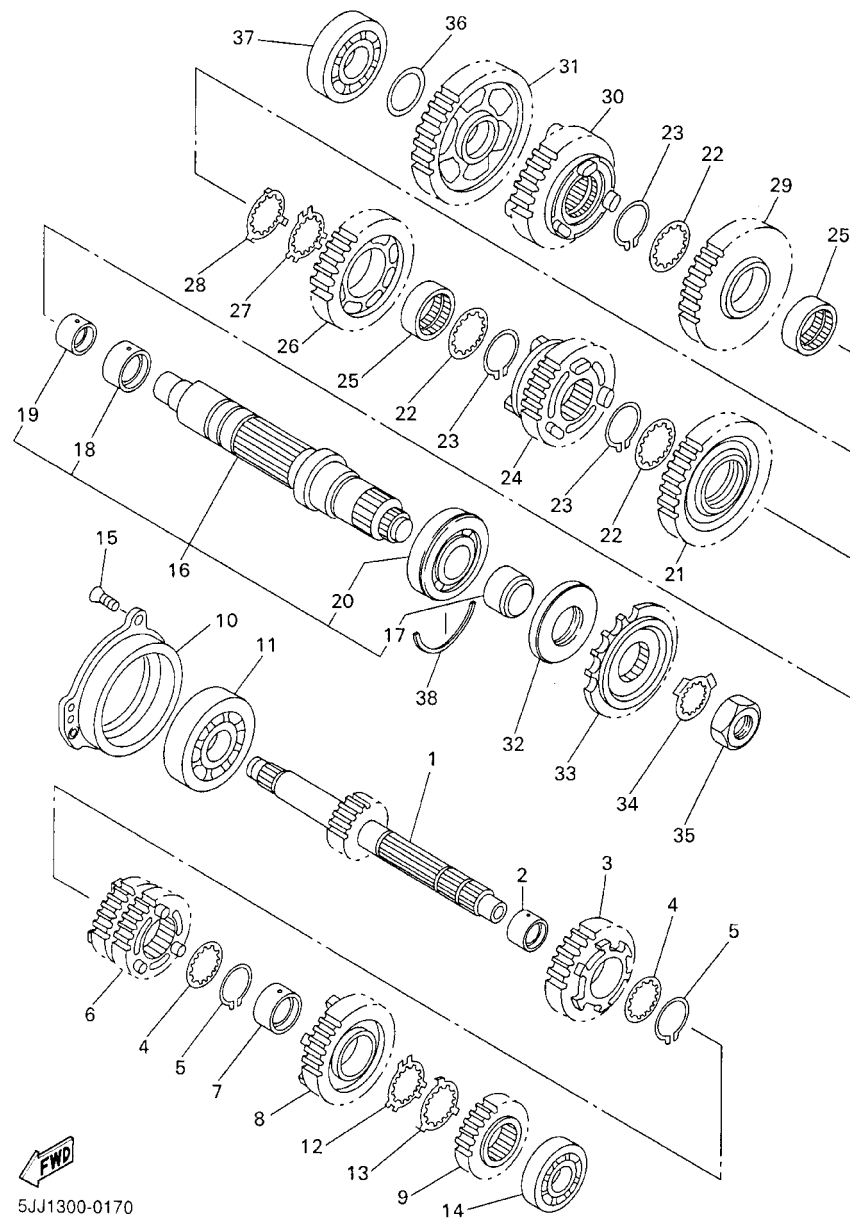

FIG. 16 CLUTCH

REF. NO.	PART NO.	DESCRIPTION	5PW7				REMARKS
28	93315-31502	BEARING	1				
29	90201-10614	WASHER, PLATE	1				
30	99009-10400	CIRCLIP	1				
31	4XV-16154-00	PLATE, THRUST 1	1				
32	5PW-13354-01	SPROCKET, DRIVE	1				
33	90201-43008	WASHER, PLATE	1				
<hr/>							
<hr/>							
<hr/>							
<hr/>							
<hr/>							
<hr/>							
<hr/>							
<hr/>							
<hr/>							
<hr/>							



5JJ1300-0170

FIG. 17 TRANSMISSION

REF. NO.	PART NO.	DESCRIPTION	5PW7				REMARKS
1	5JJ-17411-01	AXLE, MAIN (14T)	1				
2	90387-2811B	COLLAR	1				
3	5JJ-17151-00	GEAR, 5TH PINION (25T)	1				
4	90209-25342	WASHER	2				
5	93440-28062	CIRCLIP	2				
6	5JJ-17131-00	GEAR, 3RD PINION (20/21T)	1				
7	90387-2810U	COLLAR	1				
8	5JJ-17161-00	GEAR, 6TH PINION (26T)	1				
9	5JJ-17121-01	GEAR, 2ND PINION (19T)	1				
10	5JJ-15163-00	HOUSING, BEARING 1	1				
11	93306-37807	BEARING	1				
12	90209-25349	WASHER	1				
13	90209-25350	WASHER	1				
14	93306-27208	BEARING	1				
15	90149-06286	SCREW	3				
16	5JJ-17402-00	DRIVE AXLE ASSY	1				
17	5JJ-17158-00	.COLLAR 1	1				
18	90387-3311C	.COLLAR	1				
19	90387-2511A	.COLLAR	1				
20	93306-20705	.BEARING (B6207N)	1				
21	5JJ-17221-00	GEAR, 2ND WHEEL (35T)	1				
22	90209-30344	WASHER	3				
23	93440-32063	CIRCLIP	3				
24	5PW-17261-00	GEAR, 6TH WHEEL (29T)	1				
25	90387-3310V	COLLAR	2				
26	5JJ-17241-00	GEAR, 4TH WHEEL (28T)	1				
27	90209-30345	WASHER	1				

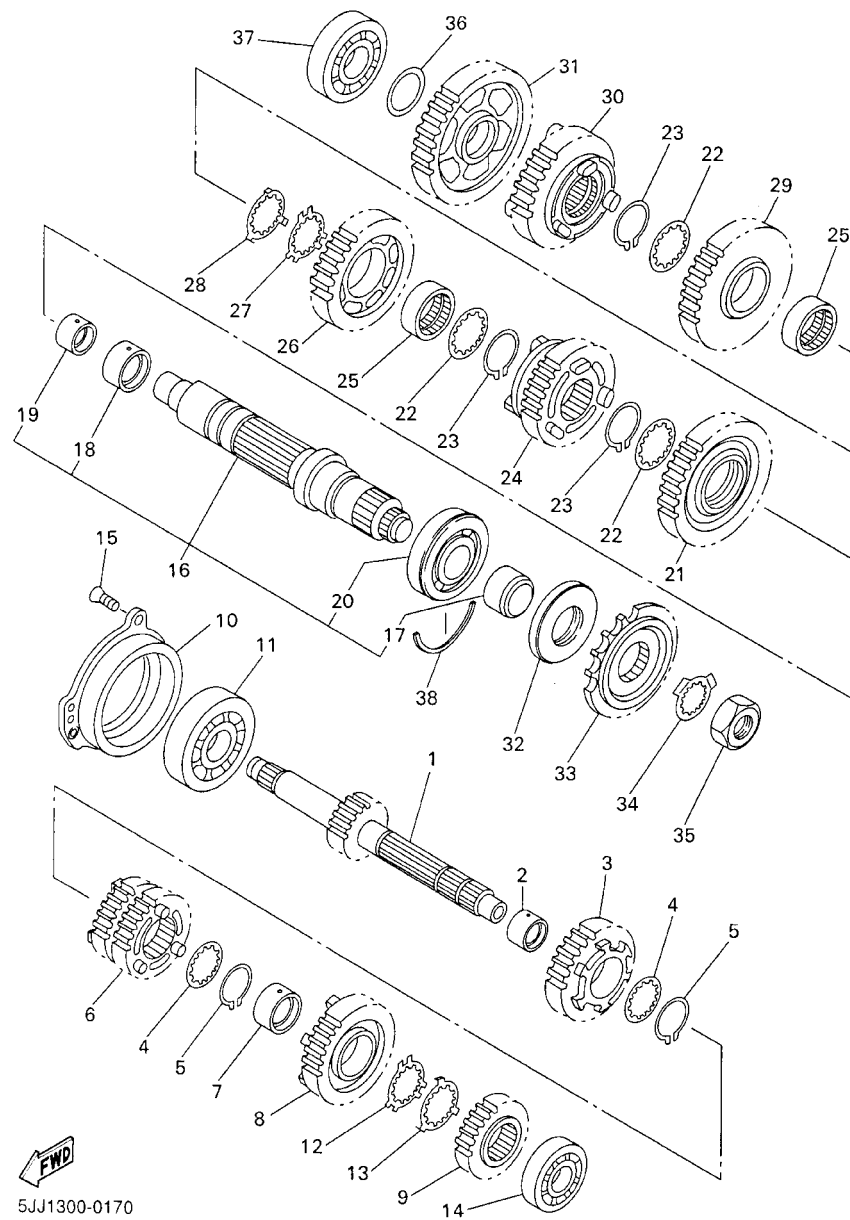

5JJ1300-0170

FIG. 17 TRANSMISSION

REF. NO.	PART NO.	DESCRIPTION	5PW7				REMARKS
28	90209-30343	WASHER	1				
29	5JJ-17231-00	GEAR, 3RD WHEEL (30T)	1				
30	5JJ-17251-10	GEAR, 5TH WHEEL (30T)	1				
31	5JJ-17211-00	GEAR, 1ST WHEEL (35T)	1				
32	93102-45465	OIL SEAL	1				
33	4XV-17460-00	SPROCKET, DRIVE (16T)	1				
34	90215-30233	WASHER, LOCK	1				
35	90179-22003	NUT	1				
36	90201-224L4	WASHER, PLATE	1				
37	93306-37209	BEARING	1				
38	93440-72049	CIRCLIP	1				

FIG. 18 SHIFT CAM. FORK

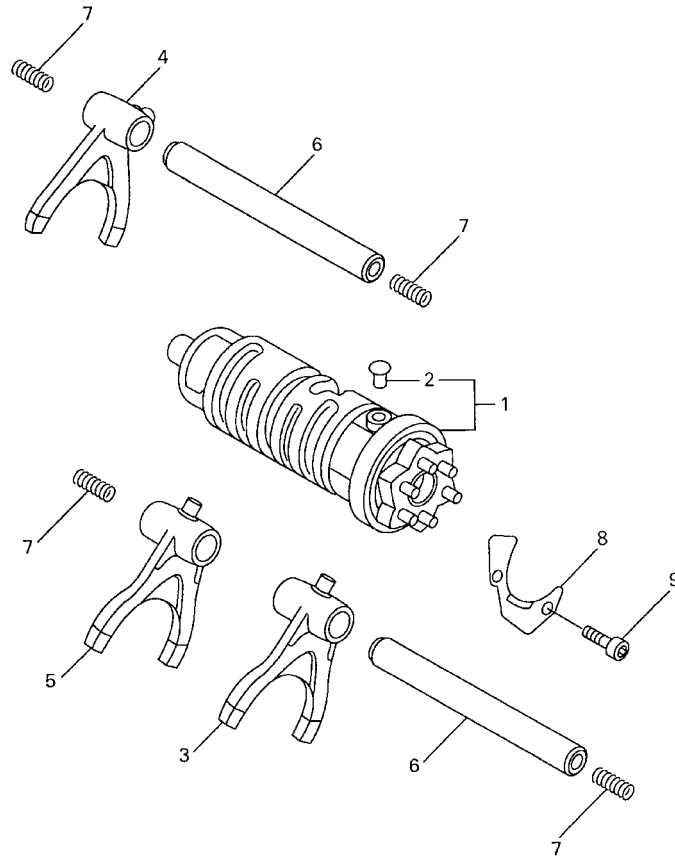

REF. NO.	PART NO.	DESCRIPTION	5PW7				REMARKS
1	5PW-18540-00	SHIFT CAM ASSY	1				
2	136-18542-00	.POINT, NEUTRAL	1				
3	4XV-18511-00	FORK, SHIFT 1	1				
4	5JJ-18512-00	FORK, SHIFT 2	1				
5	5PW-18513-00	FORK, SHIFT 3	1				
6	4XV-18531-00	BAR, SHIFT FORK GUIDE 1	2				
7	90501-064L1	SPRING, COMPRESSION	4				
8	4XV-18536-00	STOPPER, SHIFT BAR	1				
9	90110-06226	BOLT, HEXAGON SOCKET HEAD	2				

 4XV352-8170

FIG. 19 SHIFT SHAFT

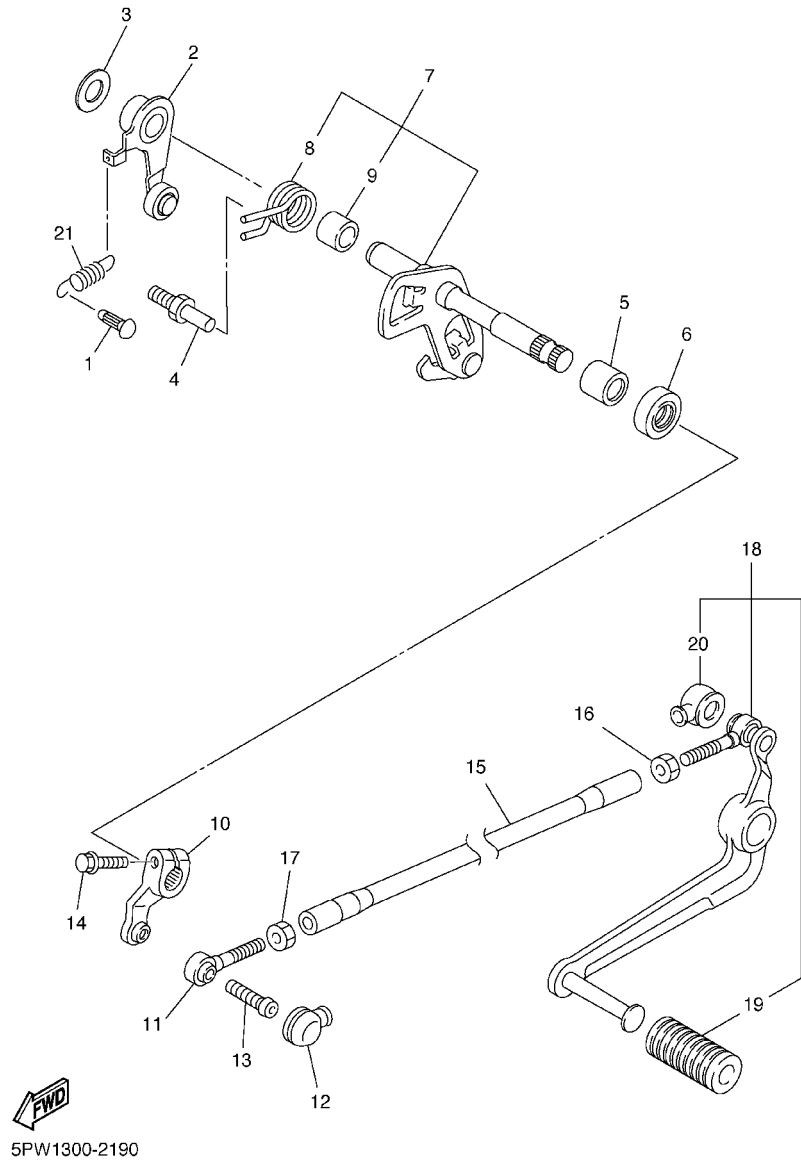

REF. NO.	PART NO.	DESCRIPTION	5PW7				REMARKS
1	132-16346-00	HOOK, SPRING	1				
2	5JJ-18140-00	STOPPER LEVER ASSY	1				
3	90201-120K4	WASHER, PLATE	1				
4	4XV-18127-00	STOPPER, SCREW	1				
5	93315-11206	BEARING	1				
6	93101-12004	OIL SEAL	1				
7	5PW-18101-00	SHIFT SHAFT ASSY	1				
8	90508-32682	.SPRING, TORSION	1				
9	90387-1211D	.COLLAR	1				
10	5PW-18112-00	ARM, SHIFT	1				
11	5LV-18116-00	JOINT, ROD 1	1				
12	4XV-18154-00	COVER, DUST	1				
13	90111-06019	BOLT	1				
14	95824-06020	BOLT, FLANGE	1				
15	5PW-18115-00	ROD, SHIFT	1				
16	90170-06228	NUT(COUNTER CLOCKWISE)	1				
17	95304-06700	NUT	1				
18	5PW-18110-00	SHIFT PEDAL ASSY	1				
19	5EB-18113-00	.COVER, SHIFT PEDAL	1				
20	4XV-18154-00	.COVER, DUST	1				
21	90506-16005	SPRING, TENSION	1				

FIG. 20 FRAME

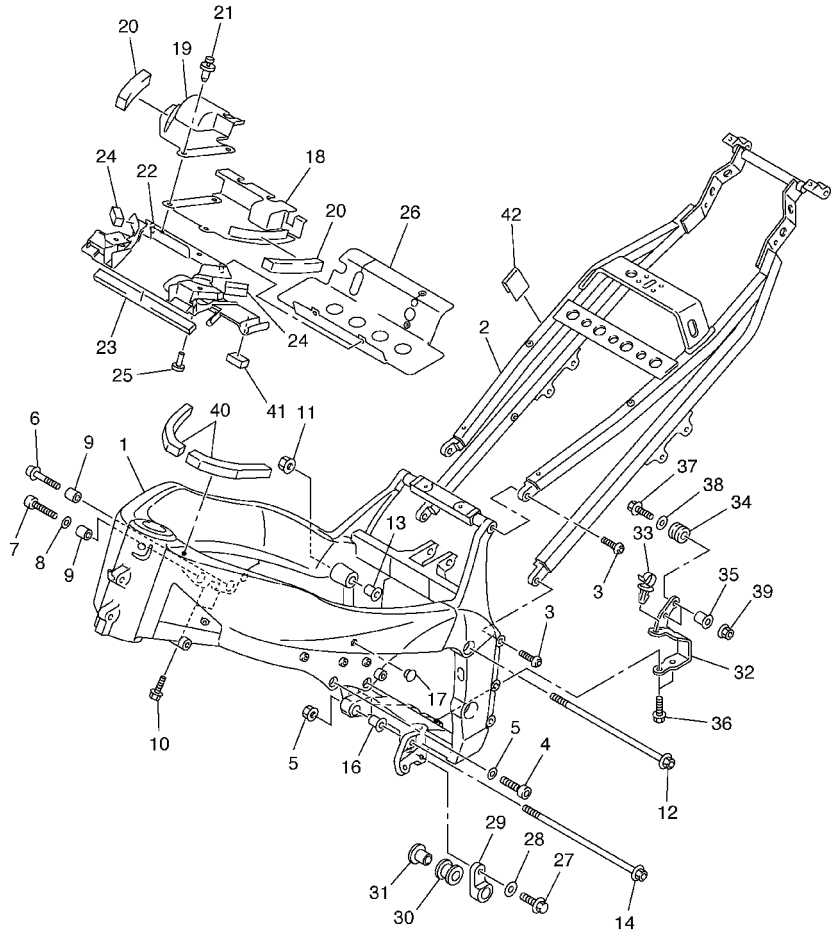

REF. NO.	PART NO.	DESCRIPTION	5PW7				REMARKS
1	5PW-21110-00	FRAME COMP.	1				
2	5PW-21190-00	REAR FRAME COMP.	1				
3	5PW-21631-09	BOLT 1	4				
4	91314-10040	BOLT	2				
5	90201-10020	WASHER, PLATE	2				
6	91314-10050	BOLT	1				
7	91314-10040	BOLT	1				
8	90201-10020	WASHER, PLATE	2				
9	90387-12012	COLLAR	2				
10	95024-08035	BOLT, FLANGE	2				
11	90179-10696	NUT	1				
12	90109-104G5	BOLT	1				
13	5EB-21495-00	BOLT, ENGINE ADJUSTING	1				
14	90110-10005	BOLT, HEXAGON SOCKET HEAD	1				
15	90179-10696	NUT	1				
16	5EB-21495-00	BOLT, ENGINE ADJUSTING	1				
17	90338-15004	PLUG	2				
18	5PW-2117M-00	COVER 2	1				
19	5PW-2117N-00	COVER 3	1				
20	5PW-21852-00	DAMPER	2				
21	90269-07076	RIVET	3				
22	5PW-2137Y-00	GUIDE, AIR	1				
23	5PW-21486-00	DAMPER 2	1				
24	5PW-21488-00	DAMPER	2				
25	90269-08002	RIVET	2				
26	5PW-2117F-00	COVER	1				
27	95817-08025	BOLT, FLANGE	1				

5PW8351-B200

FIG. 20 FRAME

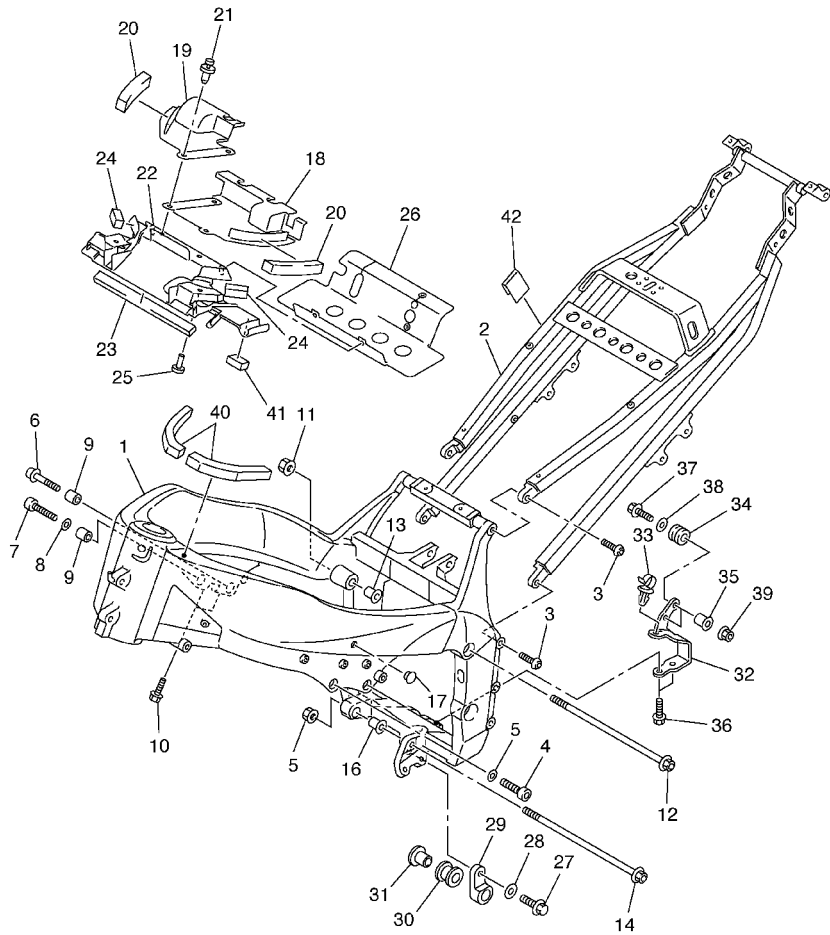

REF. NO.	PART NO.	DESCRIPTION	5PW7				REMARKS
28	90201-08326	WASHER, PLATE	1				
29	5PW-21446-00	STAY, MUFFLER 2	1				
30	4XV-27424-00	DAMPER, FOOTREST 2	1				
31	90387-08005	COLLAR	1				
32	5PW-2116J-00	BRACKET 7	1				
33	90464-09001	CLAMP	1				
34	90480-14604	GROMMET	2				
35	90387-06M60	COLLAR	2				
36	95807-06014	BOLT, FLANGE	2				
37	95027-06025	BOLT, FLANGE	2				
38	90201-06063	WASHER, PLATE	2				
39	95707-06500	NUT, FLANGE	2				
40	3YF-2414J-10	DAMPER, PLATE 2	2				
41	4J2-21778-00	DAMPER, LOCATING 1	1				
42	5PX-21268-00	SEAL	3				

 5PW8351-B200

FIG. 21 FENDER

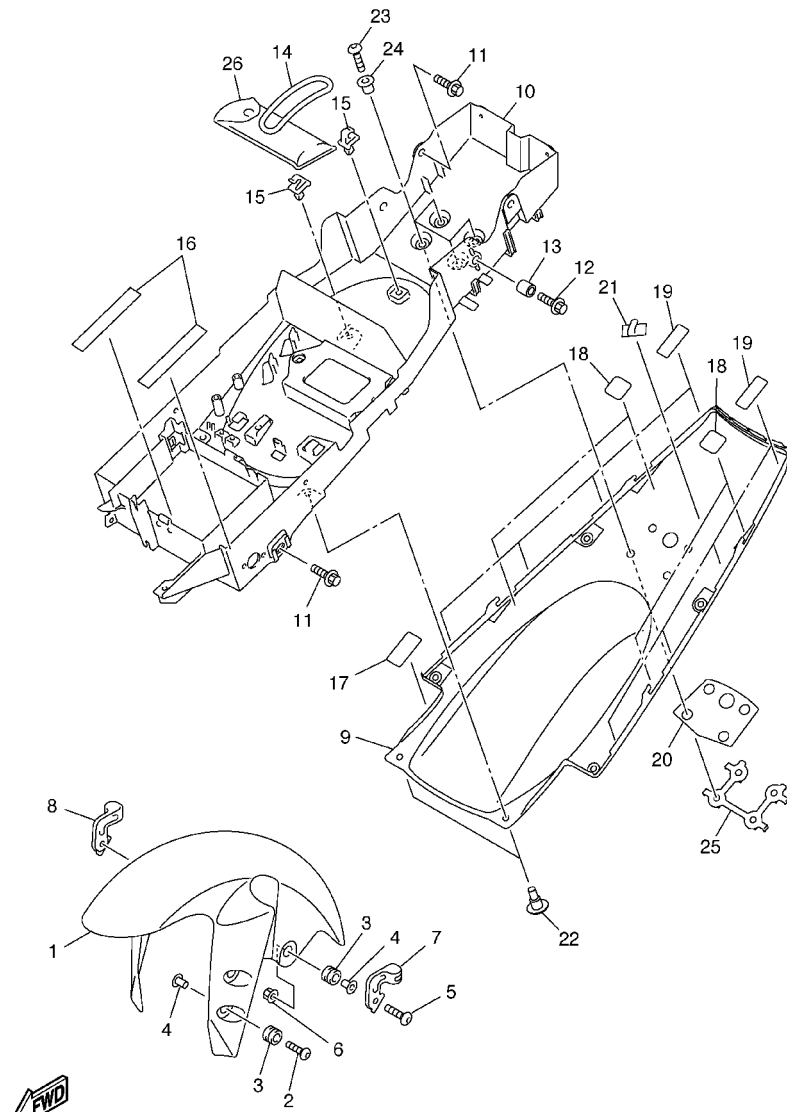

5PW1300-2210

REF. NO.	PART NO.	DESCRIPTION	5PW7				REMARKS
1	5PW-21511-00-P0	FENDER, FRONT	1				VRC1
	5PW-21511-00-P1	FENDER, FRONT	1				DPBMC
	5PW-21511-00-P2	FENDER, FRONT	1				S3
2	90111-06043	BOLT	4				
3	90480-12072	GROMMET	6				
4	90387-065J6	COLLAR	6				
5	90111-06030	BOLT	2				
6	95707-06500	NUT, FLANGE	2				
7	5PW-25875-00	HOLDER, BRAKE HOSE 1	1				
8	5PW-25876-00	HOLDER, BRAKE HOSE 2	1				
9	5PW-21611-00-P0	FENDER, REAR	1				VRC1
	5PW-21611-00-P1	FENDER, REAR	1				DPBMC
	5PW-21611-00-P2	FENDER, REAR	1				S3
10	5PW-8212B-00	BOX, BATTERY 1	1				
11	90109-063F1	BOLT	4				
12	90119-06118	BOLT, WITH WASHER	2				
13	90387-08057	COLLAR	2				
14	4XV-21376-00	BAND, TOOL	1				
15	90464-07259	CLAMP	2				
16	1AE-2834E-00	DAMPER 1	2				
17	5PX-21268-00	SEAL	1				
18	1UF-15379-00	SEAL, CRANKCASE	4				
19	5PW-21732-00	SEAL 1	8				
20	5PW-21669-00	SEAL	1				
21	90465-04020	CLAMP	1				
22	90269-07077	RIVET	2				
23	92017-06020	BOLT	4				

FIG. 22 SIDE COVER

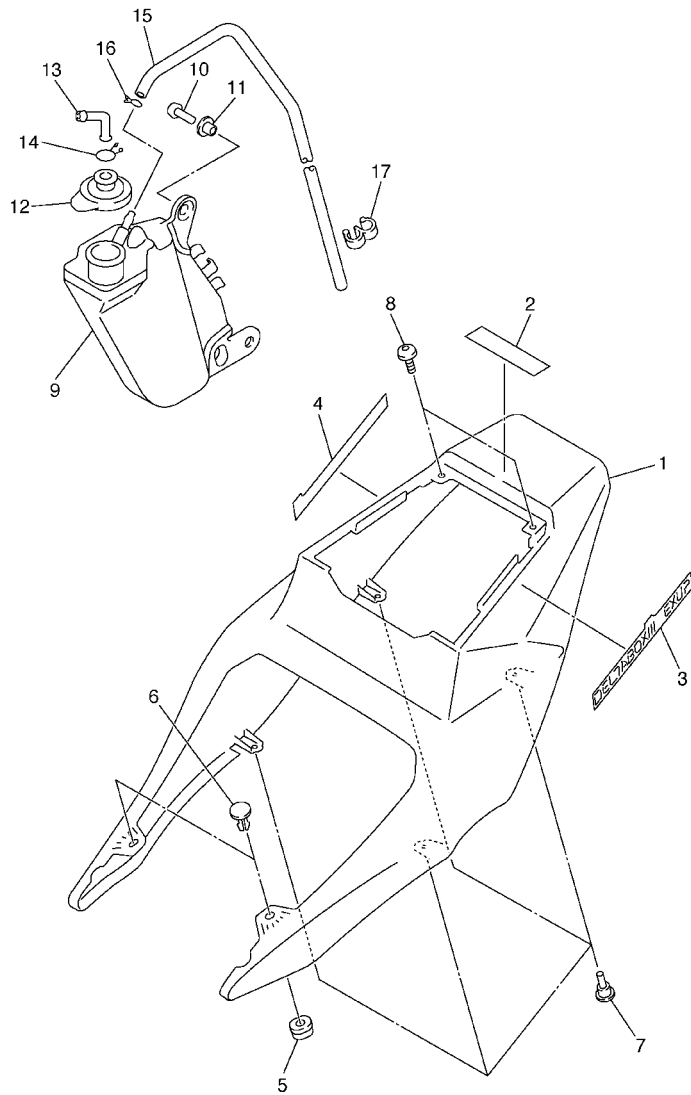

5PW8351-B220

REF. NO.	PART NO.	DESCRIPTION	5PW7				REMARKS
1	5PW-21711-00-P0	COVER, SIDE 1	1				VRC1
	5PW-21711-00-P1	COVER, SIDE 1	1				DPBMC
	5PW-21711-00-P2	COVER, SIDE 1	1				S3
2	99241-00080	EMBLEM, YAMAHA	1				FOR VRC1
	99246-00080	EMBLEM, YAMAHA	1				FOR DPBMC
	99247-00080	EMBLEM, YAMAHA	1				FOR S3
3	5PW-28328-30	EMBLEM	1				FOR VRC1
	5PW-28328-40	EMBLEM	1				FOR DPBMC
4	5PW-28338-30	EMBLEM	1				FOR VRC1
	5PW-28338-40	EMBLEM	1				FOR DPBMC
5	5PW-2174X-00	DAMPER	2				
6	90269-07076	RIVET	2				
7	90269-07077	RIVET	4				
8	90150-05039	SCREW, ROUND HEAD	2				
9	5PW-21871-00	TANK, RECOVERY	1				
10	92017-06012	BOLT, BUTTON HEAD	2				
11	90387-062M9	COLLAR	2				
12	5EB-21875-00	CAP	1				
13	26H-21828-00	ELBOW	1				
14	90467-11019	CLIP	1				
15	90445-081H0	HOSE (L460)	1				
16	90467-08003	CLIP	1				
17	90464-09M31	CLAMP	1				

FIG. 23 REAR ARM

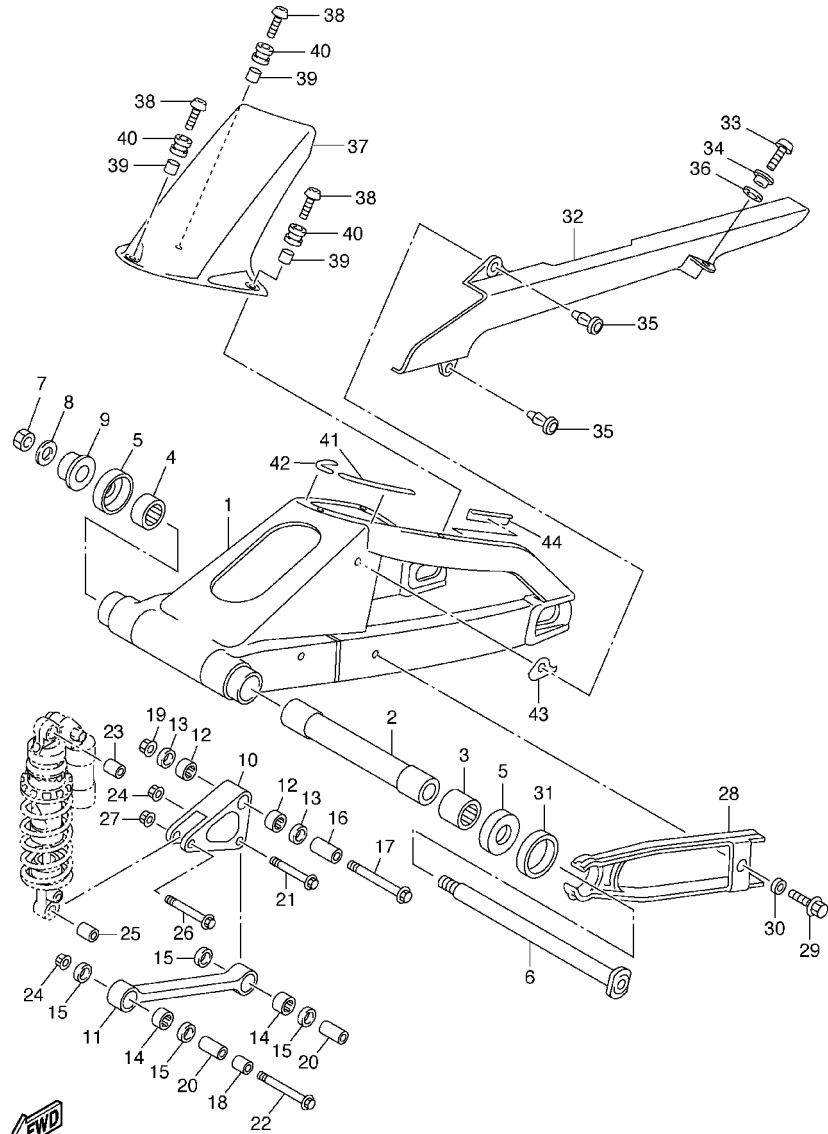

5PW1300-2230

REF. NO.	PART NO.	DESCRIPTION	5PW7				REMARKS
1	5PW-22110-00	REAR ARM COMP.	1				
2	4XV-22184-00	BUSH	1				
3	93315-42523	BEARING	1				
4	93315-42536	BEARING	1				
5	5JJ-22128-00	COVER, THRUST 1	2				
6	4FN-22141-00	SHAFT, PIVOT	1				
7	90185-18167	NUT, SELF-LOCKING	1				
8	90201-18013	WASHER, PLATE	1				
9	5PW-22125-00	BOLT	1				
10	4XV-2217A-00	ARM, RELAY	1				
11	5PW-2217M-00	ARM 1	1				
12	93315-31758	BEARING	2				
13	93109-17071	OIL SEAL	2				
14	93315-31758	BEARING	2				
15	93109-17071	OIL SEAL	4				
16	90387-1012B	COLLAR	1				
17	90105-10021	BOLT, FLANGE	1				
18	90387-1013U	COLLAR	2				
19	95607-10200	NUT, U FLANGE	1				
20	90387-1012A	COLLAR	2				
21	90105-10017	BOLT, FLANGE	1				
22	90105-10018	BOLT, FLANGE	1				
23	90387-1013U	COLLAR	1				
24	95607-10200	NUT, U FLANGE	2				
25	90387-1012A	COLLAR	1				
26	90105-10017	BOLT, FLANGE	1				
27	95607-10200	NUT, U FLANGE	1				

FIG. 23 REAR ARM

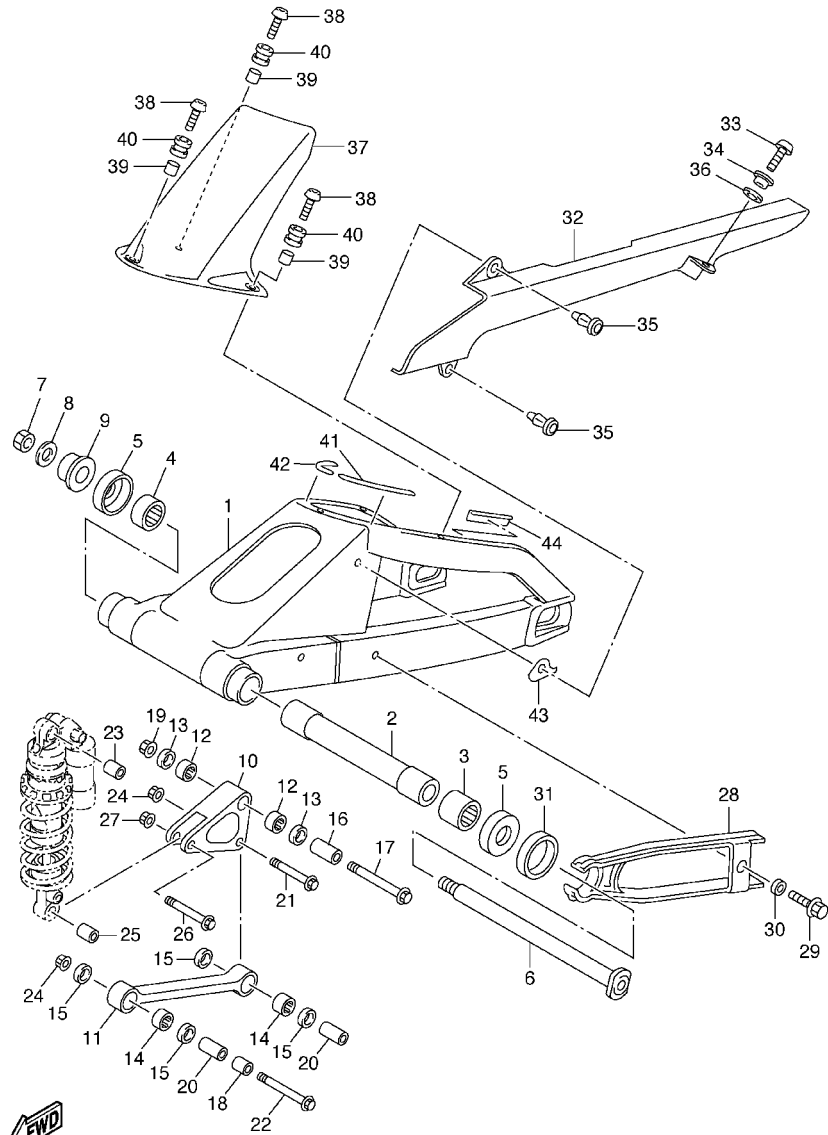

5PW1300-2230

REF. NO.	PART NO.	DESCRIPTION	5PW7				REMARKS
28	5PW-22151-00	SEAL, GUARD	1				
29	90119-06096	BOLT, WITH WASHER	1				
30	90387-06372	COLLAR	1				
31	5JJ-2214F-00	DAMPER 1	1				
32	5PW-22311-00	CASE, CHAIN	1				
33	90149-06302	SCREW	1				
34	90387-0603J	COLLAR	1				
35	90269-08002	RIVET	2				
36	5PW-28372-00	DAMPER	2				
37	5PW-21650-00-P0	REAR FENDER COMP.	1				FOR VRC1,DPBMC
	5PW-21650-00-P1	REAR FENDER COMP.	1				FOR S3
38	90149-06302	SCREW	3				
39	90387-0600V	COLLAR	3				
40	90480-12005	GROMMET	3				
41	5PW-22873-00	SEAL 1	1				
42	5PW-22874-00	SEAL 2	1				
43	5PW-22875-00	SEAL 3	1				
44	5PW-22876-00	SEAL 4	1				

FIG. 24 REAR SUSPENSION

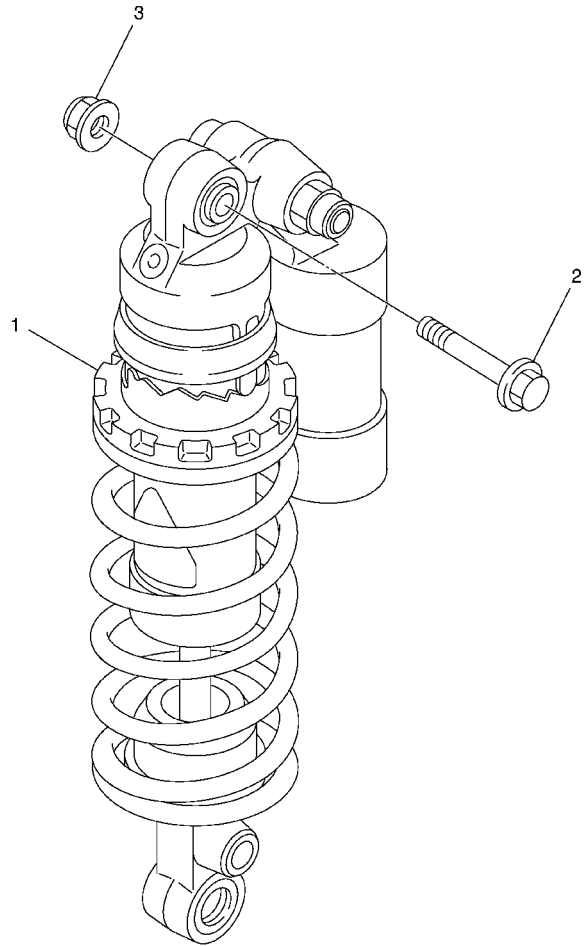

REF. NO.	PART NO.	DESCRIPTION	5PW7				REMARKS
1	5PW-22210-00	SHOCK ABSORBER ASSY, REAR	1				
2	90105-10020	BOLT, FLANGE	1				
3	95607-10200	NUT, U FLANGE	1				



5PW1300-2240

FIG. 25 STEERING

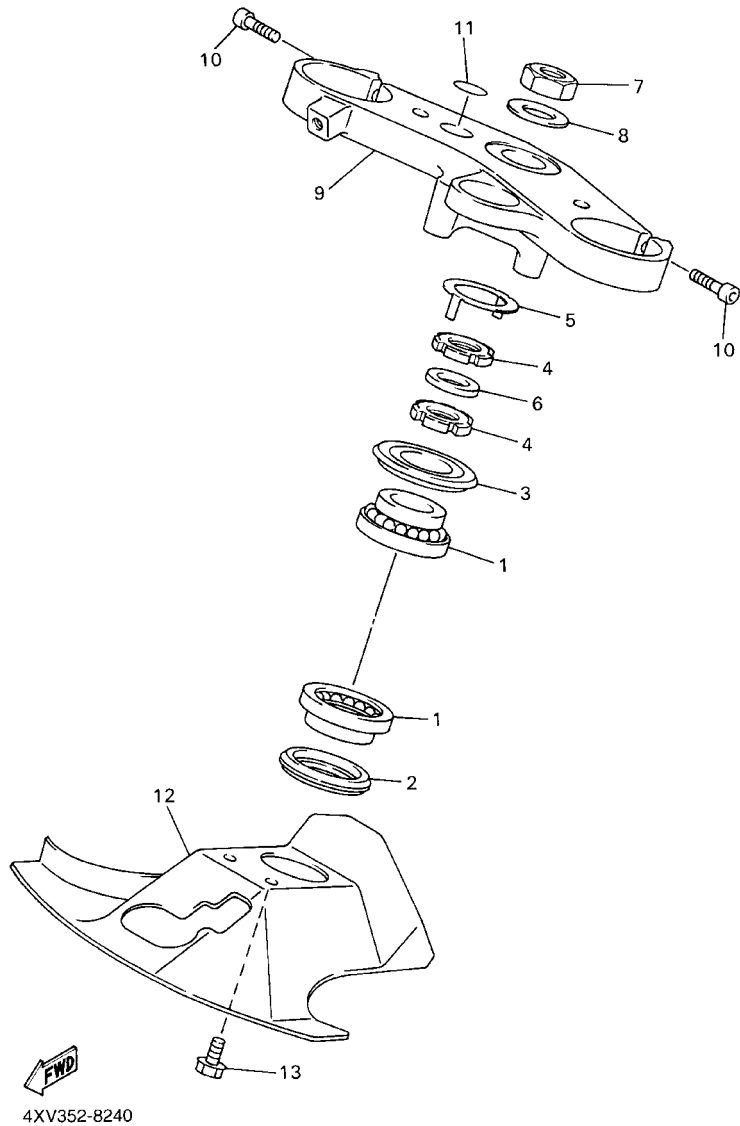

REF. NO.	PART NO.	DESCRIPTION	5PW7				REMARKS
1	93399-99932	BEARING	2				
2	3FV-23462-00	SEAL, STEERING	1				
3	4XV-23415-01	COVER, BALL RACE 1	1				
4	90179-30691	NUT	2				
5	4XV-23418-00	WASHER, SPECIAL	1				
6	90202-30235	WASHER, PLATE	1				
7	90170-28419	NUT	1				
8	90201-281U8	WASHER, PLATE	1				
9	5PW-23435-00	CROWN, HANDLE	1				
10	91314-08030	BOLT	2				
11	4XV-2341B-00	EMBLEM	1				
12	5PW-23818-00	COVER, STEERING	1				
13	90119-06114	BOLT, WITH WASHER	2				

FIG. 26 FRONT FORK

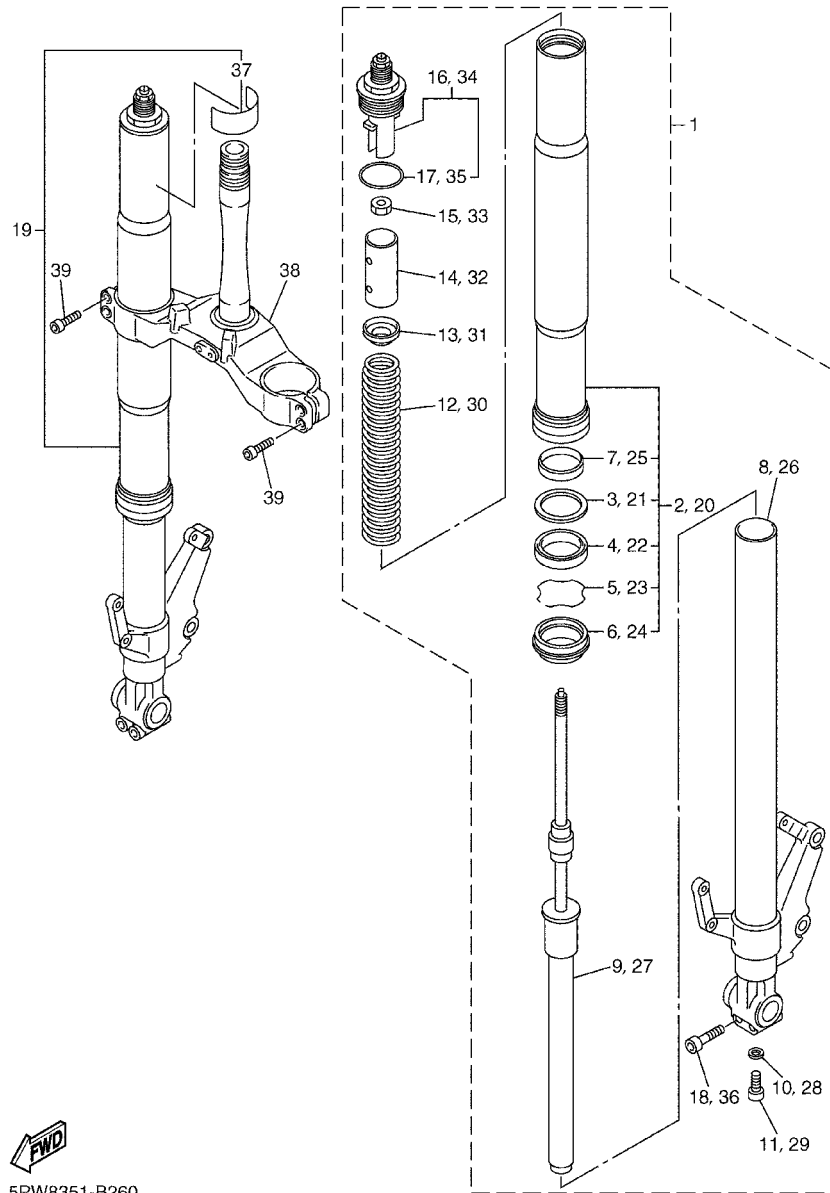

5PW8351-B260

REF. NO.	PART NO.	DESCRIPTION	5PW7				REMARKS
1	5PW-23102-11	FRONT FORK ASSY (L.H)	1				FOR VRC1,DPBMC
	5PW-23102-01	FRONT FORK ASSY (L.H)	1				FOR S3
2	5PW-23136-10	.TUBE, OUTER (RIGHT)	1				FOR VRC1,DPBMC
	5PW-23136-00	.TUBE, OUTER (RIGHT)	1				FOR S3
3	5PW-23146-00	..WASHER, OIL SEAL	1				
4	5PW-23145-00	..OIL SEAL	1				
5	4V4-23153-L0	..RING, SNAP	1				
6	4PU-23144-00	..SEAL, DUST	1				
7	5PW-23125-00	..METAL, SLIDE 1	1				
8	5PW-23110-00	.INNER TUBE COMP.1	1				
9	5PW-23170-00	.CYLINDER COMP., FRONT FORK	1				
10	2K8-23158-L0	.GASKET	1				
11	3LC-23181-00	.BOLT, HEXAGON SOCKET HEAD	1				
12	5PW-23141-00	.SPRING, FRONT FORK	1				
13	4XV-23142-00	.SEAT, SPRING UPPER	1				
14	5PW-23118-00	.SPACER	1				
15	3LC-23357-00	.NUT	1				
16	5PW-23111-00	.BOLT, CAP	1				
17	3XJ-23147-L0	..O-RING	1				
18	91314-08040	.BOLT	2				
19	5PW-23103-11	FRONT FORK ASSY (R.H)	1				FOR VRC1,DPBMC
	5PW-23103-01	FRONT FORK ASSY (R.H)	1				FOR S3
20	5PW-23136-10	.TUBE, OUTER (RIGHT)	1				FOR VRC1,DPBMC
	5PW-23136-00	.TUBE, OUTER (RIGHT)	1				FOR S3
21	5PW-23146-00	..WASHER, OIL SEAL	1				
22	5PW-23145-00	..OIL SEAL	1				
23	4V4-23153-L0	..RING, SNAP	1				



5PW8351-B260

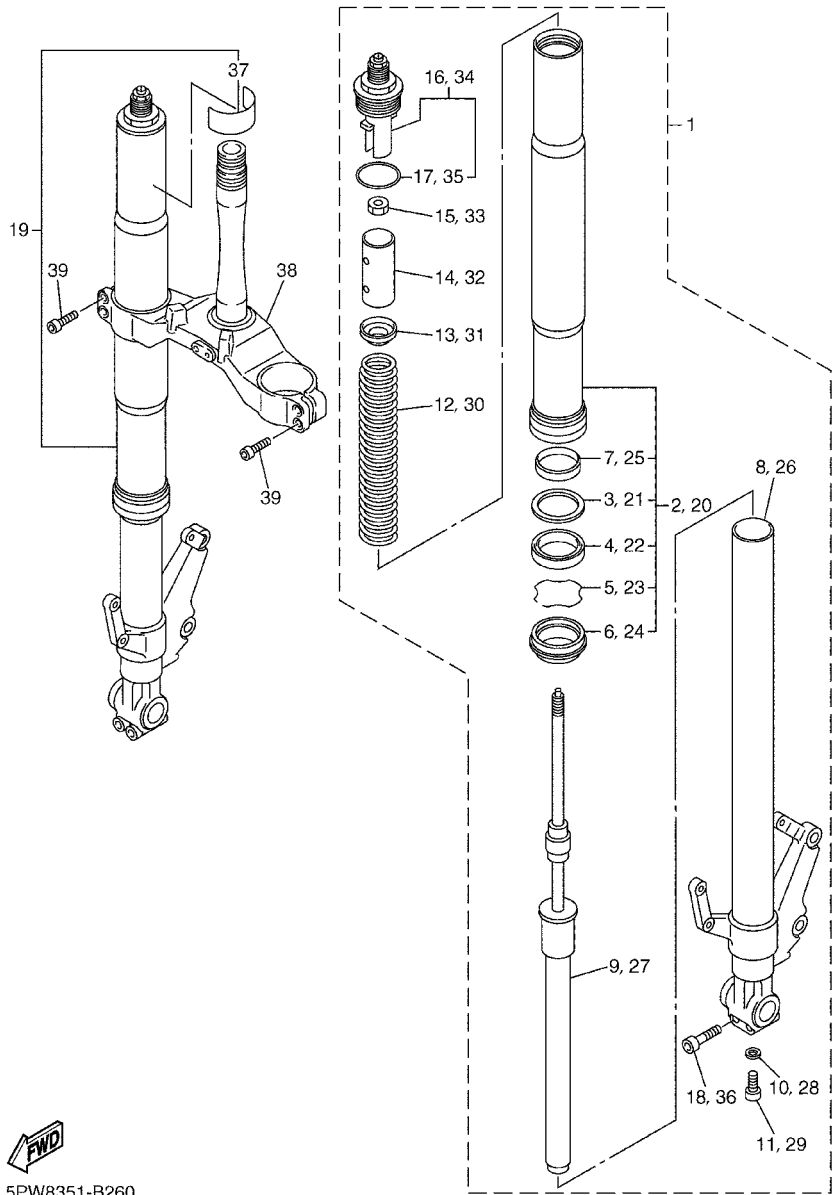
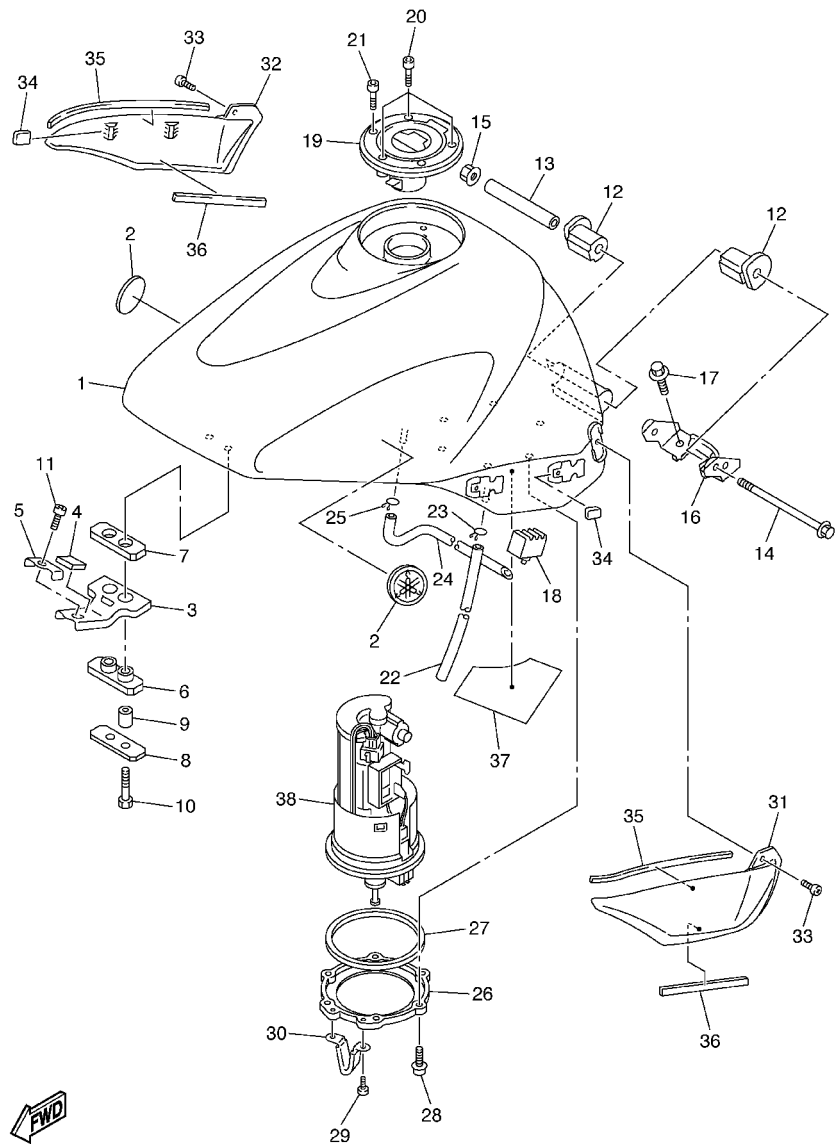

FIG. 26 FRONT FORK

REF. NO.	PART NO.	DESCRIPTION	5PW7				REMARKS
24	4PU-23144-00	..SEAL, DUST	1				
25	5PW-23125-00	..METAL, SLIDE 1	1				
26	5PW-23120-00	.INNER TUBE COMP.2	1				
27	5PW-23170-00	.CYLINDER COMP., FRONT FORK	1				
28	2K8-23158-L0	.GASKET	1				
29	3LC-23181-00	.BOLT, HEXAGON SOCKET HEAD	1				
30	5PW-23141-00	.SPRING, FRONT FORK	1				
31	4XV-23142-00	.SEAT, SPRING UPPER	1				
32	5PW-23118-00	.SPACER	1				
33	3LC-23357-00	.NUT	1				
34	5PW-23111-00	.BOLT, CAP	1				
35	3XJ-23147-L0	..O-RING	1				
36	91314-08040	.BOLT	2				
37	5PW-23472-00	.PROTECTOR	1				
38	5PW-23340-00	UNDER BRACKET COMP.	1				
39	91314-08030	BOLT	4				

FIG. 27 FUEL TANK



5PW8351-B270

REF. NO.	PART NO.	DESCRIPTION	5PW7				REMARKS
1	5PW-YK241-30-P0	FUEL TANK COMP.	1				VRC1
	5PW-YK241-30-P1	FUEL TANK COMP.	1				DPBMC
	5PW-YK241-M0-P0	FUEL TANK COMP.	1				S3
2	5PW-2413B-00	EMBLEM	2				
3	5PW-24191-00	BRACKET, FUEL TANK 1	1				
4	1AE-2837J-00	DAMPER 5	1				
5	5JJ-24186-00	WASHER, SPECIAL	1				
6	2GH-24181-00	DAMPER, LOCATING 1	1				
7	2GH-24183-00	DAMPER, LOCATING 3	1				
8	5JJ-24187-00	WASHER, SPECIAL	1				
9	90387-06006	COLLAR	2				
10	90119-06190	BOLT, WITH WASHER	2				
11	91314-06016	BOLT	1				
12	4YR-24181-00	DAMPER, LOCATING 1	2				
13	90387-06007	COLLAR	1				
14	95817-06110	BOLT, FLANGE	1				
15	95607-06200	NUT, SELF U-FLANGE	1				
16	5PW-2413Y-00	BRACKET, TANK FITTING	1				
17	90119-06044	BOLT, WITH WASHER	2				
18	4XV-24183-00	DAMPER, LOCATING 3	2				
19	5JJ-24602-00	CAP ASSY	1				
20	90110-05112	BOLT, HEXAGON SOCKET HEAD	3				
21	91317-05010	BOLT	1				
22	90445-102G7	HOSE (L800)	1				
23	90467-09006	CLIP	1				
24	5PW-24312-00	PIPE 2	1				
25	90467-09006	CLIP	1				

FIG. 27 FUEL TANK

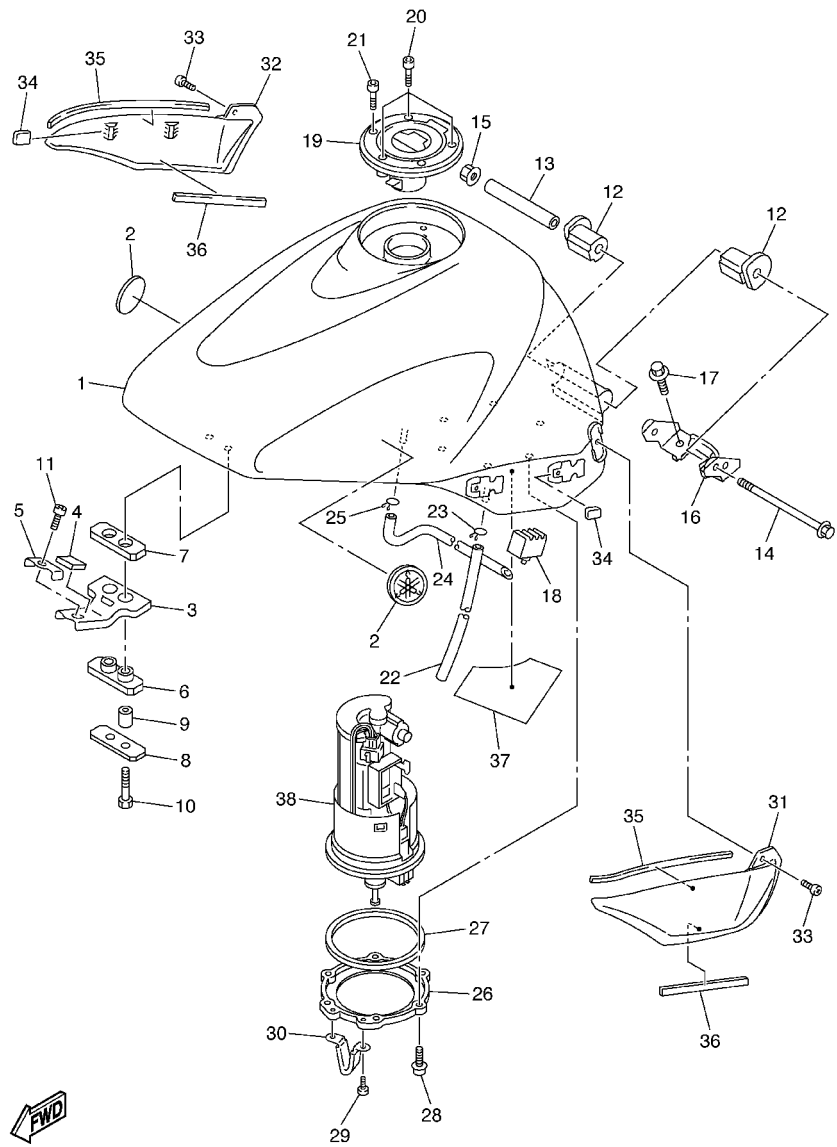

5PW8351-B270

REF. NO.	PART NO.	DESCRIPTION	5PW7				REMARKS
26	5PW-24491-00	BRACKET, FUEL PUMP	1				
27	5JW-24486-00	O-RING	1				
28	90110-05014	BOLT, HEXAGON SOCKET HEAD	6				
29	98907-05008	SCREW, BIND	2				
30	5PW-24192-00	BRACKET, FUEL TANK 2	1				
31	5PW-24129-00	COVER, SIDE 1	1				
32	5PW-24139-00	COVER, SIDE 2	1				
33	90154-05074	SCREW, BINDING	2				
34	5PW-2411J-00	DAMPER, SIDE COVER	4				
35	5PW-2414H-00	DAMPER, PLATE 1	2				
36	5PW-2414J-00	DAMPER, PLATE 2	2				
37	5PW-2414I-00	PROTECTOR, FUEL TANK	1				
38	5PW-13907-00	FUEL PUMP COMP.	1				

FIG. 28 SEAT

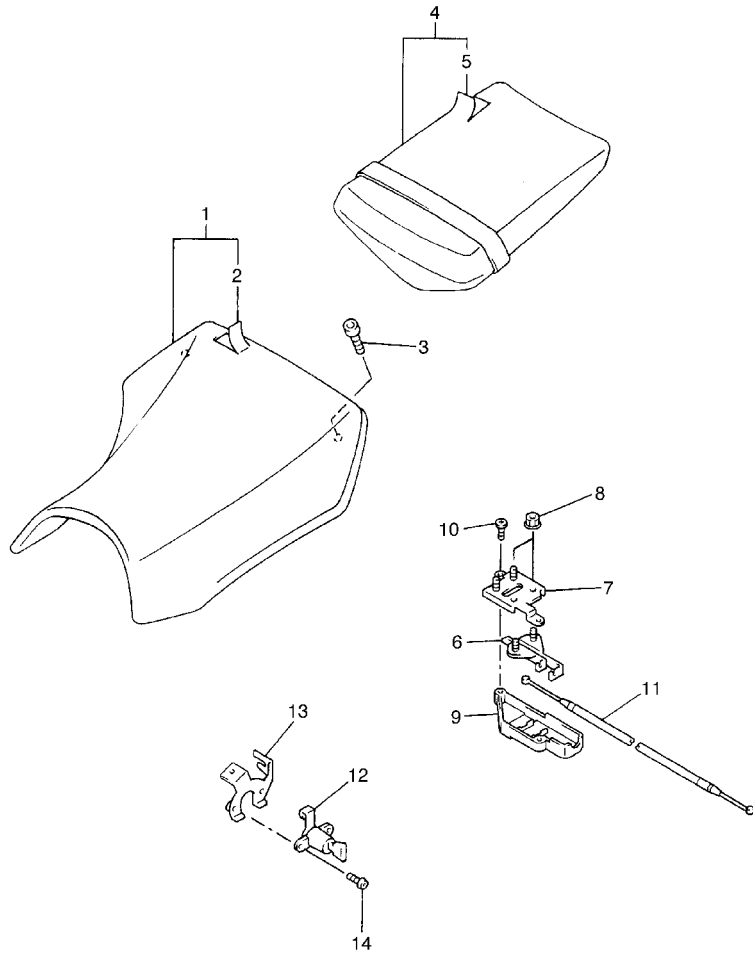

REF. NO.	PART NO.	DESCRIPTION	5PW7				REMARKS
1	5PW-24710-01	SINGLE SEAT ASSY	1				
2	5PW-2470F-00	.SEAT COVER COMP.	1				
3	90110-06258	BOLT, HEXAGON SOCKET HEAD	2				
4	5PW-24750-00	TANDEM SEAT ASSY	1				
5	5PW-24751-00	.COVER, TANDEM SEAT	1				
6	4BP-24780-00	SEAT LOCK ASSY	1				
7	5JJ-24792-01	PLATE	1				
8	95707-06500	NUT, FLANGE	4				
9	5JJ-2475X-01	COVER,2	1				
10	97707-40012	SCREW, TAPPING	2				
11	5JJ-2478E-00	CABLE, SEAT LOCK	1				
12	2TV-W2470-00	SEAT LOCK ASSY	1				
13	5PW-2117K-00	STAY, LOCK	1				
14	90149-06308	SCREW	2				



5PW1300-2280

FIG. 29 FRONT WHEEL

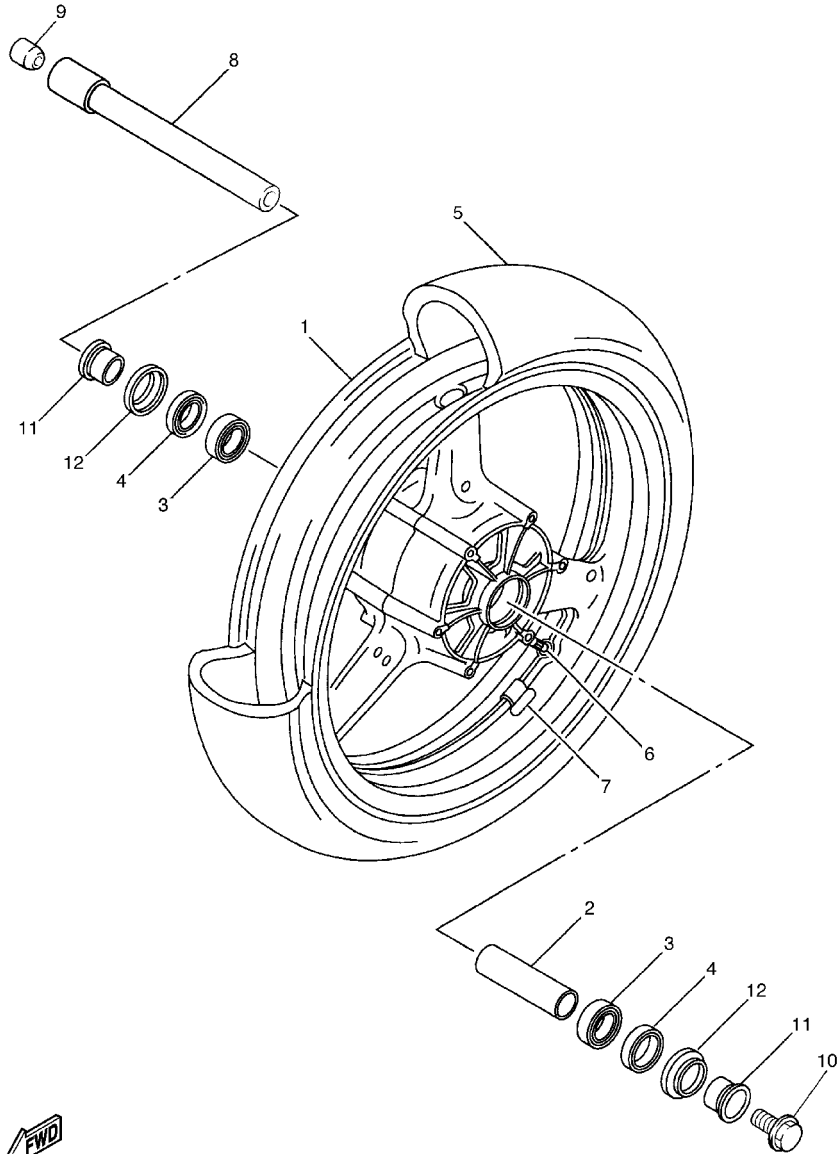

REF. NO.	PART NO.	DESCRIPTION	5PW7				REMARKS
1	5PW-25168-00-98	CAST WHEEL, FRONT	1				LGB
2	4XV-25117-00	SPACER, BEARING	1				
3	93306-00420	BEARING (B6004)	2				
4	93106-28043	OIL SEAL	2				
5	94112-17054	TIRE (120/70 ZR17M/C 58W D208F)	1				DUNLOP FOR GBR,ITA
*		TIRE (120/70 ZR17M/C 58W Pilot SPORT G)	1				LM MICHELIN
6	93900-00030	VALVE, RIM (TR412)	1				
7	5MT-25398-00	BALANCER, WHEEL (10G)	1				UN
	5MT-25398-10	BALANCER, WHEEL (20G)	1				UN
	5MT-25398-20	BALANCER, WHEEL (30G)	1				UN
8	5PW-25181-00	AXLE, WHEEL	1				
9	5PW-25188-00	CAP	1				
10	90105-14002	BOLT, FLANGE	1				
11	4XV-25186-00	COLLAR, WHEEL	2				
12	4XV-25118-00	COVER, HUB DUST	2				



5PW1300-2290

FIG. 30 FRONT BRAKE CALIPER

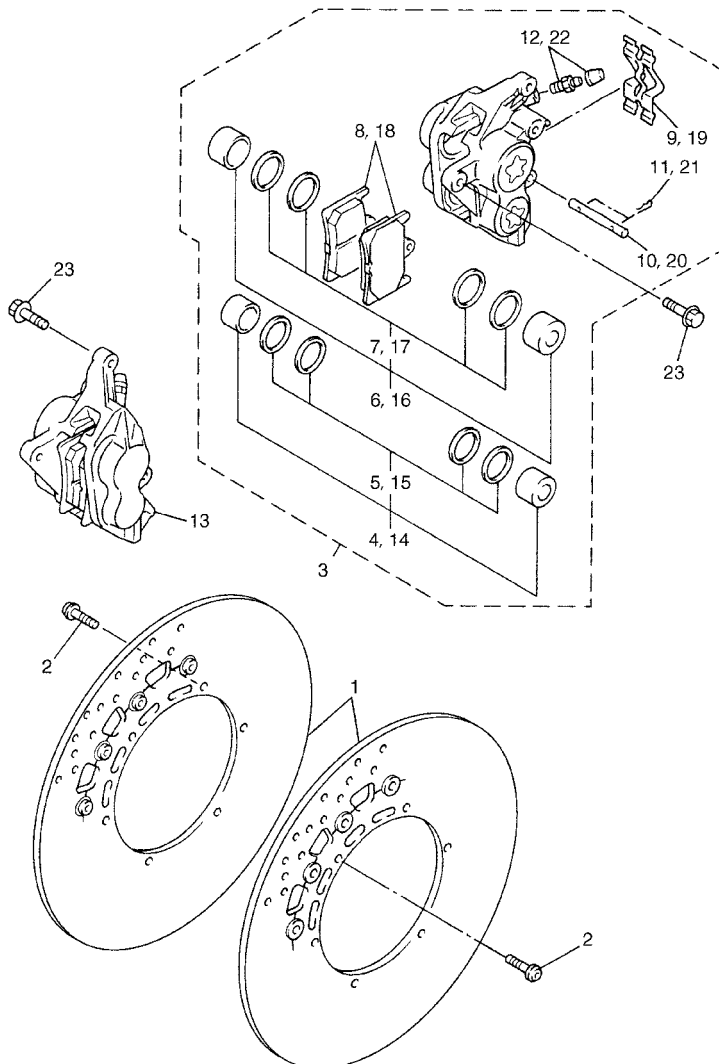

REF. NO.	PART NO.	DESCRIPTION	5PW7				REMARKS
1	5JJ-2581T-10	DISC BRAKE ASSY	2				
2	90109-064G6	BOLT	12				
3	5PW-2580T-00	CALIPER ASSY (LEFT)	1				
4	5PW-W0057-00	.PISTON ASSY, CALIPER	1				
5	5PW-W0047-00	..CALIPER SEAL KIT	1				
6	5PW-W0057-10	.PISTON ASSY, CALIPER	1				
7	5PW-W0047-10	..CALIPER SEAL KIT	1				
8	5PW-W0045-00	.BRAKE PAD KIT	1				
9	4SV-25919-00	.SUPPORT, PAD	1				
10	4SV-25924-00	.PIN, PAD	1				
11	3GM-25925-00	.CLIP	2				
12	1J3-W0048-00	.BLEED SCREW KIT	1				
13	5PW-2580U-00	CALIPER ASSY (RIGHT)	1				
14	5PW-W0057-00	.PISTON ASSY, CALIPER	1				
15	5PW-W0047-00	..CALIPER SEAL KIT	1				
16	5PW-W0057-10	.PISTON ASSY, CALIPER	1				
17	5PW-W0047-10	..CALIPER SEAL KIT	1				
18	5PW-W0045-00	.BRAKE PAD KIT	1				
19	4SV-25919-00	.SUPPORT, PAD	1				
20	4SV-25924-00	.PIN, PAD	1				
21	3GM-25925-00	.CLIP	2				
22	1J3-W0048-00	.BLEED SCREW KIT	1				
23	90105-105A7	BOLT, FLANGE	4				



5PW1300-2300

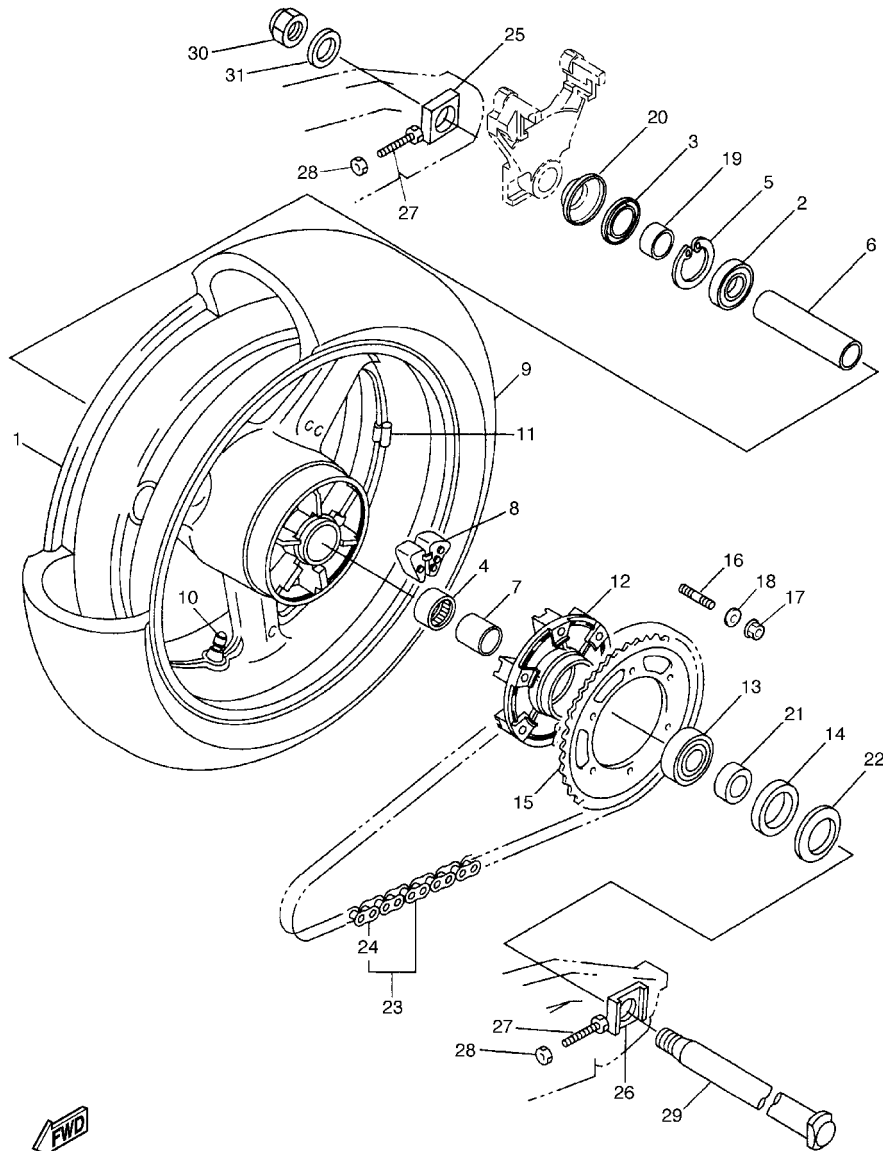

5PW1300-2310

FIG. 31 REAR WHEEL

REF. NO.	PART NO.	DESCRIPTION	5PW7				REMARKS
1	5PW-25338-01-98	CAST WHEEL, REAR	1				LGB
2	93306-20531	BEARING	1				
3	93106-40013	OIL SEAL	1				
4	93317-43580	BEARING	1				
5	93420-61M07	CIRCLIP	1				
6	5PW-25317-00	SPACER, BEARING	1				
7	4XV-25383-00	COLLAR, WHEEL	1				
8	5PW-25364-00	DAMPER	6				
9	94119-17019	TIRE (190/50 ZR17M/C 73W D208)	1				DUNLOP FOR GBR,ITA
	*	TIRE (190/50 ZR17M/C 73W Pilot SPORT G)	1				LM MICHELIN
10	93900-00030	VALVE, RIM (TR412)	1				
11	5MT-25398-00	BALANCER, WHEEL (10G)	1				UN
	5MT-25398-10	BALANCER, WHEEL (20G)	1				UN
	5MT-25398-20	BALANCER, WHEEL (30G)	1				UN
12	5PW-25366-00	CLUTCH, HUB	1				
13	93306-20531	BEARING	1				
14	93106-40013	OIL SEAL	1				
15	4XV-25443-21	SPROCKET, DRIVEN (43T)	1				
16	90116-10485	BOLT, STUD	6				
17	90185-10009	NUT, SELF-LOCKING	6				
18	90201-10021	WASHER, PLATE	6				
19	5PW-25377-00	COLLAR, WHEEL	1				
20	5PW-25367-00	COVER, HUB DUST	1				
21	4XV-25376-00	COLLAR, WHEEL	1				
22	5JJ-25367-00	COVER, HUB DUST	1				
23	9Y582-05113	CHAIN (DID50VA8-113LL)	1				
24	94682-05031	.JOINT, CHAIN	1				

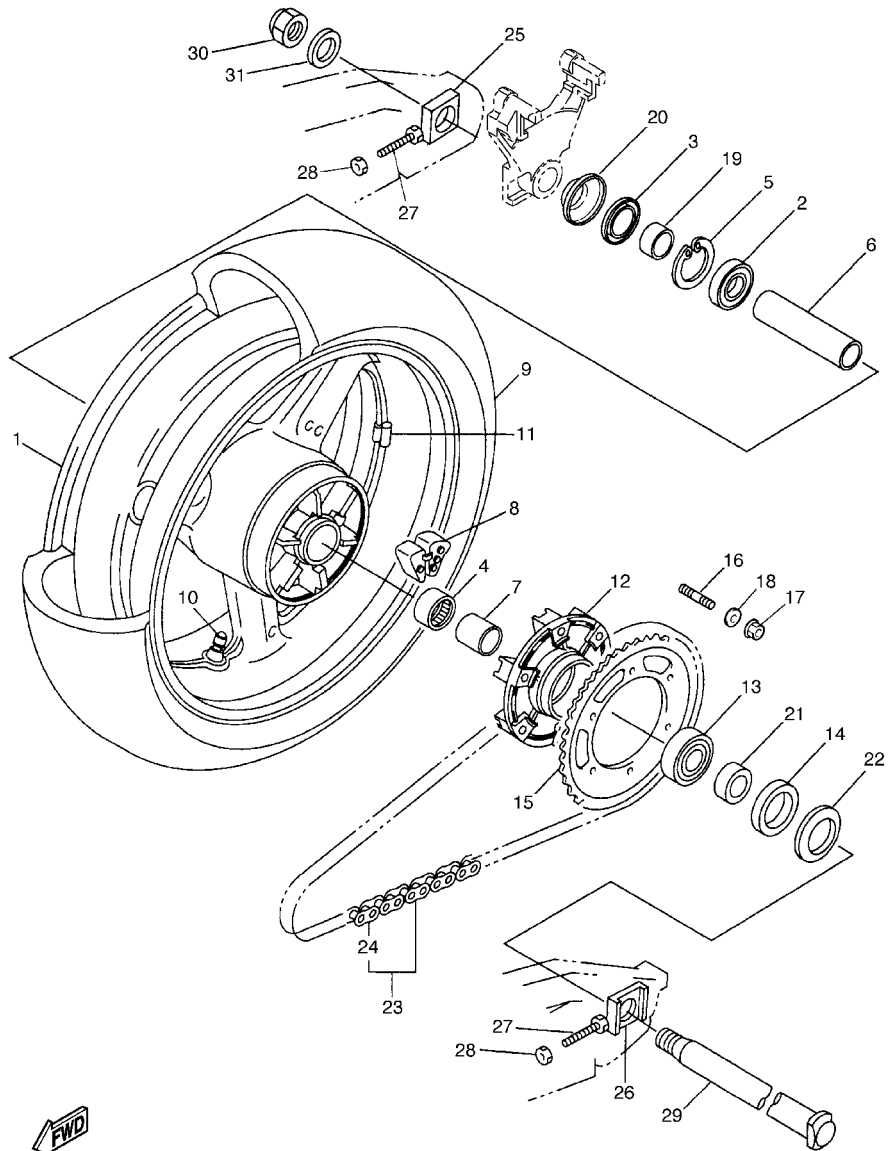
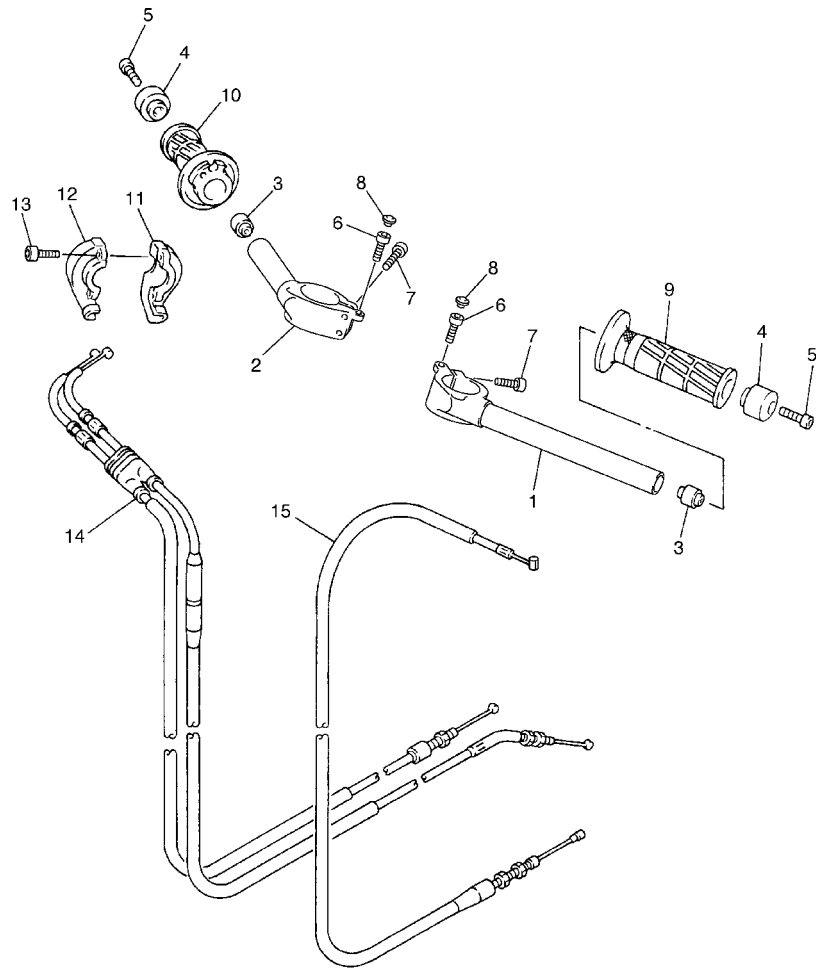

FIG. 31 REAR WHEEL

REF. NO.	PART NO.	DESCRIPTION	5PW7				REMARKS
25	4XV-25388-00	PULLER, CHAIN 1	1				
26	4XV-25389-00	PULLER, CHAIN 2	1				
27	90101-08766	BOLT	2				
28	95307-08600	NUT	2				
29	4XV-25381-00	AXLE, WHEEL	1				
30	90185-24165	NUT, SELF-LOCKING	1				
31	90201-257R5	WASHER, PLATE	1				

 5PW1300-2310

FIG. 33 STEERING HANDLE. CABLE



REF. NO.	PART NO.	DESCRIPTION	5PW7				REMARKS
1	5PW-26121-00	HANDLEBAR (LEFT)	1				
2	5PW-26122-00	HANDLEBAR (RIGHT)	1				
3	4XV-23434-00	HOLDER, DAMPER	2				
4	5PW-26246-00	END, GRIP	2				
5	91317-06025	BOLT	2				
6	91317-06025	BOLT	2				
7	91314-06025	BOLT	4				
8	2H9-23469-00	CAP, BOLT	2				
9	4YR-26241-01	GRIP (LEFT)	1				
10	4YR-26240-01	GRIP ASSY	1				
11	3XW-26281-01	CAP, GRIP UPPER	1				
12	3XW-26282-01	CAP, GRIP LOWER	1				
13	90110-05018	BOLT, HEXAGON SOCKET HEAD	2				
14	5PW-26302-00	THROTTLE CABLE ASSY	1				
15	5PW-26335-01	CABLE, CLUTCH	1				

5PW8351-B330

FIG. 34 FRONT MASTER CYLINDER

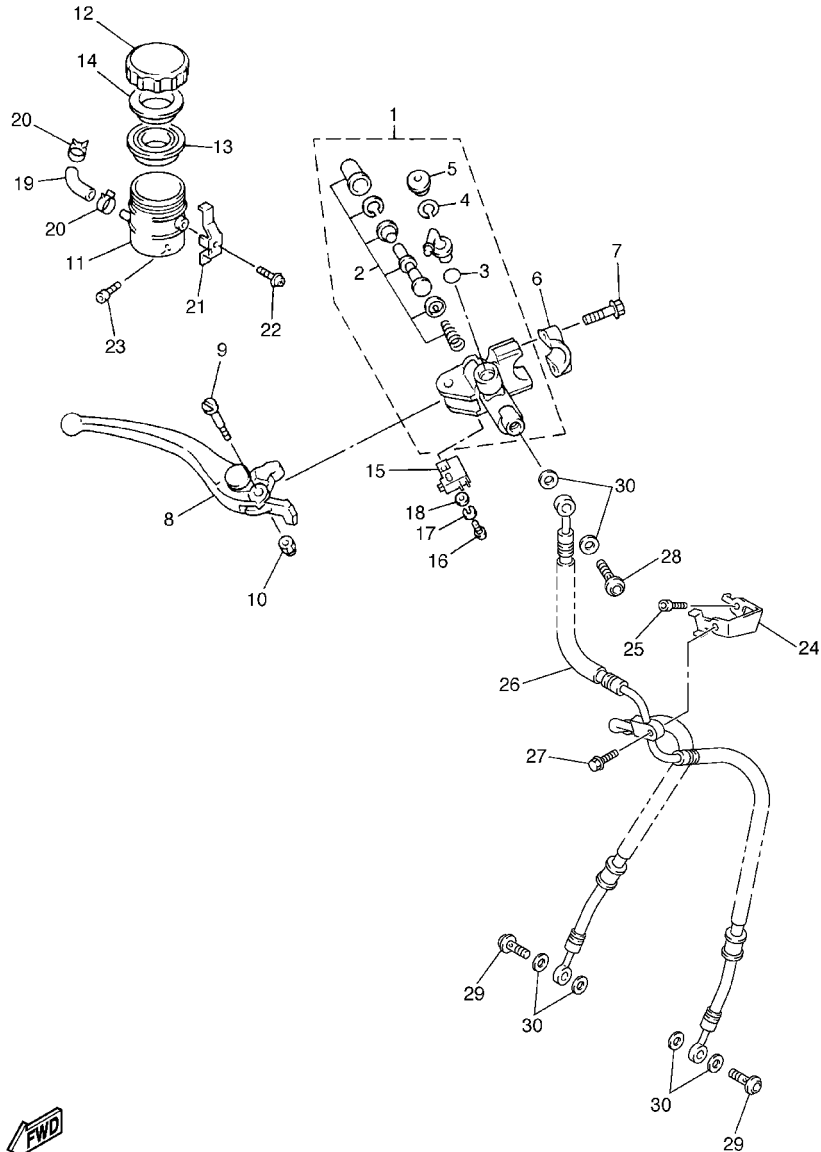

5PW1300-2340

REF. NO.	PART NO.	DESCRIPTION	5PW7				REMARKS
1	4SV-W2587-10	MASTER CYLINDER SUB ASSY	1				
2	4SV-W0041-00	.CYLINDER KIT, MASTER	1				
3	93210-15620	.O-RING	1				
4	2VN-25866-00	.CIRCLIP	1				
5	3FV-2589A-00	.COVER, DUST	1				
6	56A-25867-00	BRACKET, MASTER CYLINDER	1				
7	5PW-26332-00	BOLT	2				
8	5PW-83922-00	LEVER 2	1				
9	3FV-2589F-00	BOLT, LEVER	1				
10	95606-06100	NUT, U	1				
11	3FV-25894-00	TANK, RESERVOIR	1				
12	3GM-25852-50	CAP, RESERVOIR	1				
13	3FV-25854-00	DIAPHRAGM, RESERVOIR	1				
14	2J2-25855-50	BUSH,DIAPHRAGM	1				
15	4HM-83980-00	FRONT STOP SWITCH ASSY	1				
16	98502-04012	SCREW, PAN HEAD	1				
17	92902-04100	WASHER, SPRING	1				
18	92902-04600	WASHER, PLATE	1				
19	5PW-2582F-00	HOSE	1				
20	3PA-24356-00	CLIP, PIPE 1	2				
21	3FV-2589G-00	HOLDER	1				
22	3GM-2589H-00	SCREW	1				
23	91317-06012	BOLT	1				
24	5PW-25887-00	HOLDER, BRAKE HOSE	1				
25	91317-06012	BOLT	1				
26	5PW-25872-01	HOSE, BRAKE 1	1				
27	95027-06020	BOLT, FLANGE	1				

FIG. 34 FRONT MASTER CYLINDER

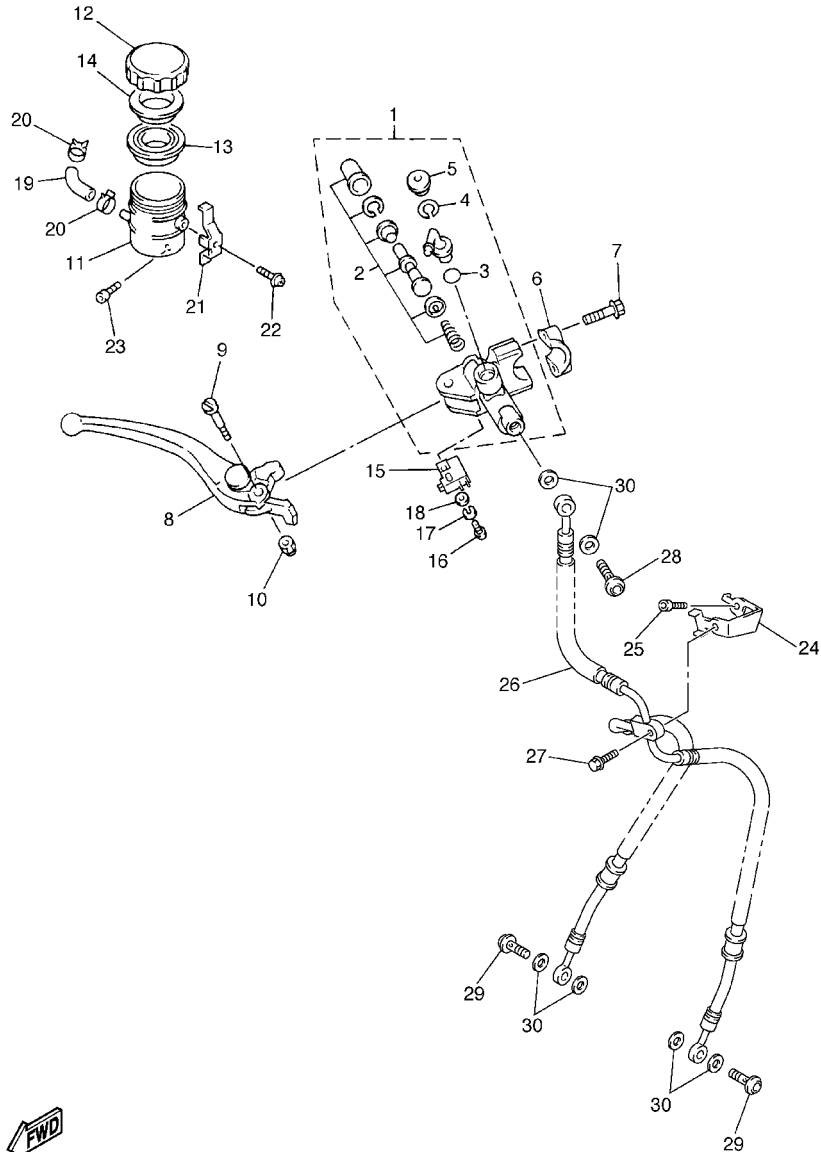

REF. NO.	PART NO.	DESCRIPTION	5PW7				REMARKS
28	90401-10172	BOLT, UNION	1				
29	90401-10172	BOLT, UNION	2				
30	90201-10118	WASHER, PLATE	6				

 5PW1300-2340

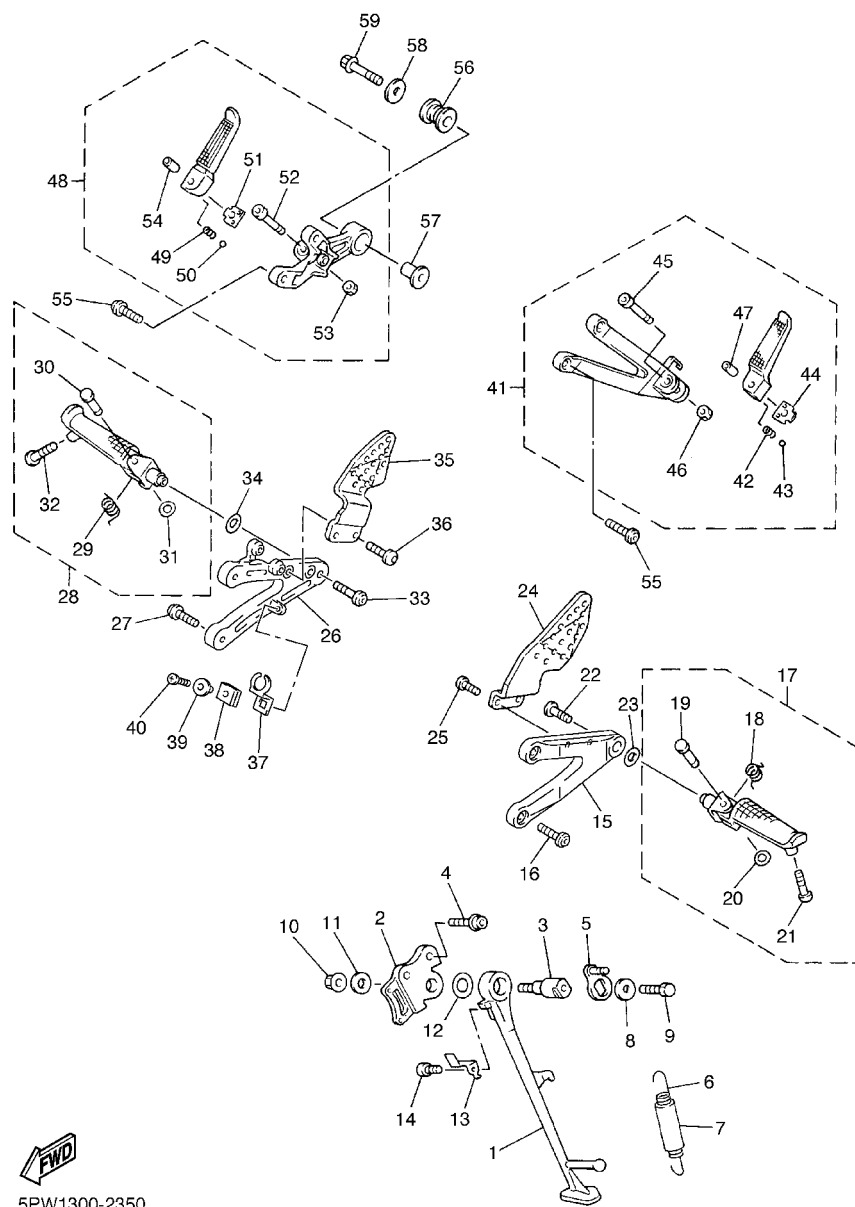

5PW1300-2350

FIG. 35 STAND. FOOTREST

REF. NO.	PART NO.	DESCRIPTION	5PW7				REMARKS
1	5PW-27311-00	STAND, SIDE	1				
2	5JJ-27321-00	BRACKET, SIDE STAND	1				
3	4NX-27351-00	GUIDE, SIDE STAND	1				
4	90109-10002	BOLT	2				
5	5PW-27352-00	HOOK, SIDE STAND	1				
6	90506-18003	SPRING, TENSION	1				
7	90445-19002	HOSE (L60)	1				
8	90201-081R9	WASHER, PLATE	1				
9	90101-08662	BOLT	1				
10	95607-10200	NUT, U FLANGE	1				
11	90201-101J1	WASHER, PLATE	1				
12	90201-146F9	WASHER, PLATE	1				
13	5JJ-27315-00	LINK, SIDE STAND	1				
14	90110-06226	BOLT, HEXAGON SOCKET HEAD	1				
15	5PW-27442-00	BRACKET 2	1				
16	90109-085G6	BOLT	2				
17	5JJ-27410-01	FRONT FOOTREST ASSY (LEFT)	1				
18	90508-18134	.SPRING, TORSION	1				
19	90243-08029	.PIN	1				
20	90201-06042	.WASHER, PLATE	1				
21	90109-083E0	.BOLT	1				
22	90149-08296	SCREW	1				
23	90201-13008	WASHER, PLATE	1				
24	5JJ-27445-00	PLATE 1	1				
25	90149-06233	SCREW	2				
26	5PW-27443-00	BRACKET 3	1				
27	90109-085G6	BOLT	2				

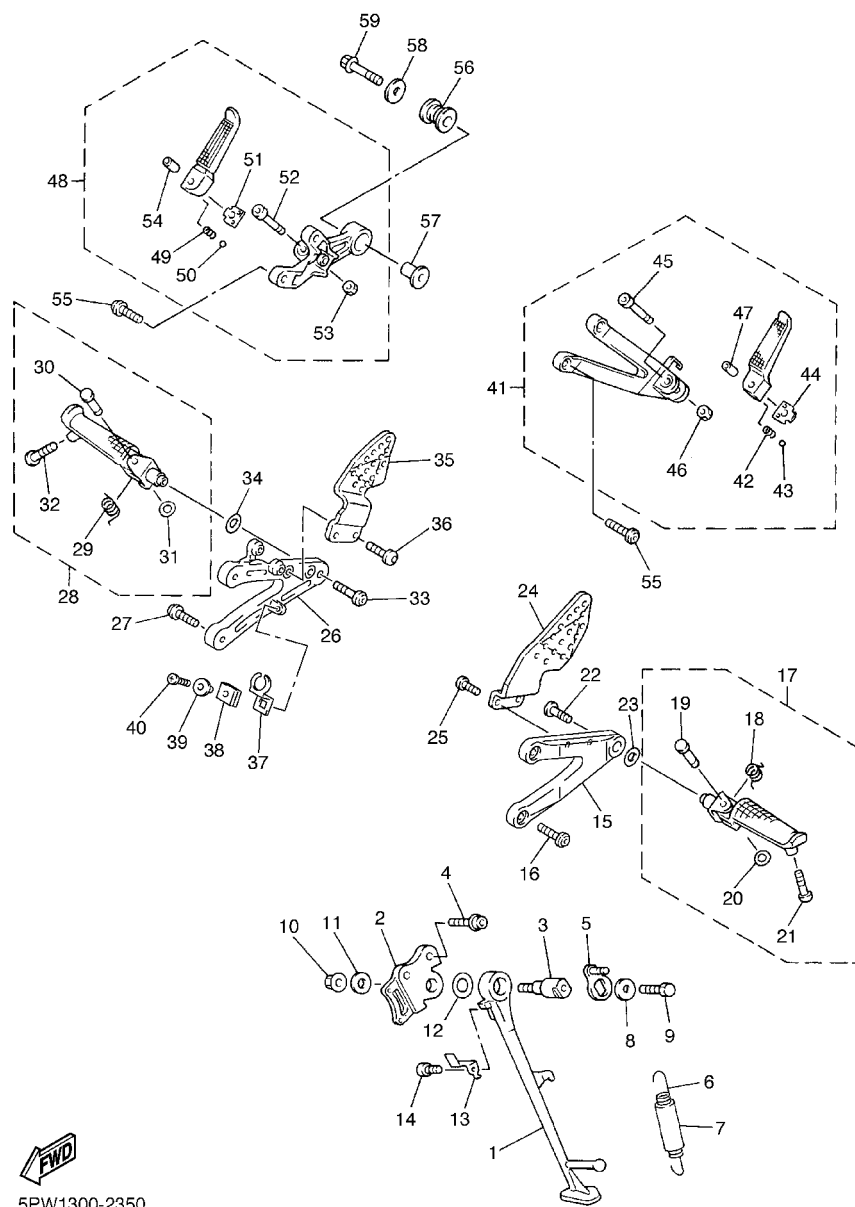

5PW1300-2350

FIG. 35 STAND FOOTREST

REF. NO.	PART NO.	DESCRIPTION	5PW7				REMARKS
28	5JJ-27420-01	FRONT FOOTREST ASSY (RIGHT)	1				
29	90508-18135	.SPRING, TORSION	1				
30	90243-08029	.PIN	1				
31	90201-06042	.WASHER, PLATE	1				
32	90109-083E0	.BOLT	1				
33	90149-08296	SCREW	1				
34	90201-13008	WASHER, PLATE	1				
35	5JJ-27446-00	PLATE 2	1				
36	90149-06233	SCREW	2				
37	5EB-2144G-00	STAY, STOP SWITCH	1				
38	90480-12607	GROMMET	1				
39	90387-06023	COLLAR	1				
40	90159-06150	SCREW, WITH WASHER	1				
41	5JJ-27430-00	REAR FOOTREST ASSY 1	1				
42	90501-12743	.SPRING, COMPRESSION	1				
43	93501-04011	.BALL	1				
44	5JJ-27437-00	.WASHER, SPECIAL	1				
45	91314-06035	.BOLT	1				
46	95604-06200	.NUT, U FLANGE	1				
47	90387-06697	.COLLAR	1				
48	5PW-27440-00	REAR FOOTREST ASSY 2	1				
49	90501-12743	.SPRING, COMPRESSION	1				
50	93501-04011	.BALL	1				
51	5JJ-27437-00	.WASHER, SPECIAL	1				
52	91314-06035	.BOLT	1				
53	95604-06200	.NUT, U FLANGE	1				
54	90387-06697	.COLLAR	1				

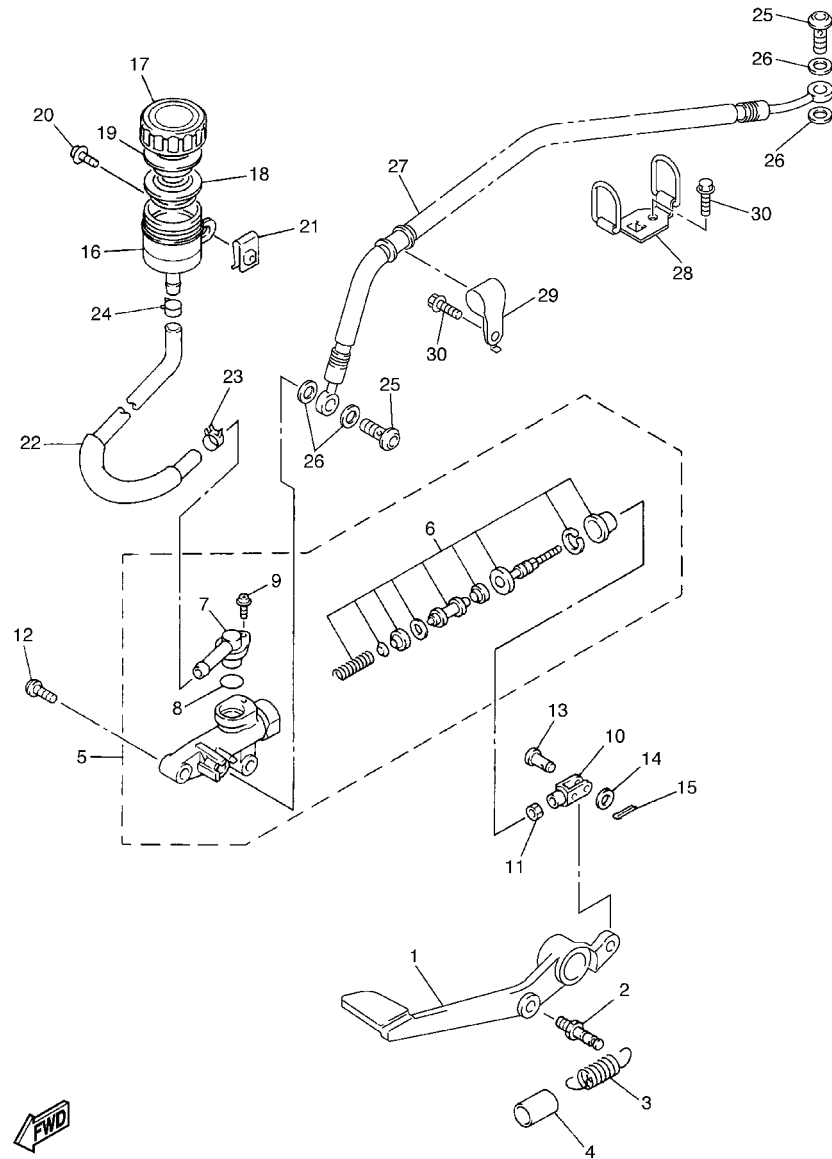

5PW1300-2360

FIG. 36 REAR MASTER CYLINDER

REF. NO.	PART NO.	DESCRIPTION	5PW7				REMARKS
1	5PW-27211-00	PEDAL, BRAKE	1				
2	5JJ-27813-00	PIN, PEDAL CRANK	1				
3	90506-20377	SPRING, TENSION	1				
4	90446-17346	HOSE	1				
5	3TU-2583V-01	RR. MASTER CYLINDER ASSY.	1				
6	3TU-W0042-51	.CYLINDER KIT, MASTER	1				
7	3LN-2582A-00	.JOINT	1				
8	3LN-2585F-00	.O-RING	1				
9	3LN-2585H-00	.SCREW,SET	1				
10	4XV-27222-01	JOINT	1				
11	95304-08700	NUT	1				
12	90109-06013	BOLT	2				
13	91701-06018	PIN, CLEVIS	1				
14	92907-06200	WASHER	1				
15	91401-16012	PIN, COTTER	1				
16	5JJ-25894-00	TANK, RESERVOIR	1				
17	3XP-25852-50	CAP, RESERVOIR	1				
18	2VN-25854-00	DIAPHRAGM, RESERVOIR	1				
19	2VN-25855-00	BUSH,DIAPHRAGM	1				
20	90159-06056	SCREW, WITH WASHER	1				
21	90183-06053	NUT, SPRING	1				
22	5PW-25895-00	HOSE, RESERVOIR	1				
23	90467-14057	CLIP	1				
24	90467-12191	CLIP	1				
25	90401-10172	BOLT, UNION	2				
26	90201-10118	WASHER, PLATE	4				
27	5PW-25874-01	HOSE, BRAKE	1				

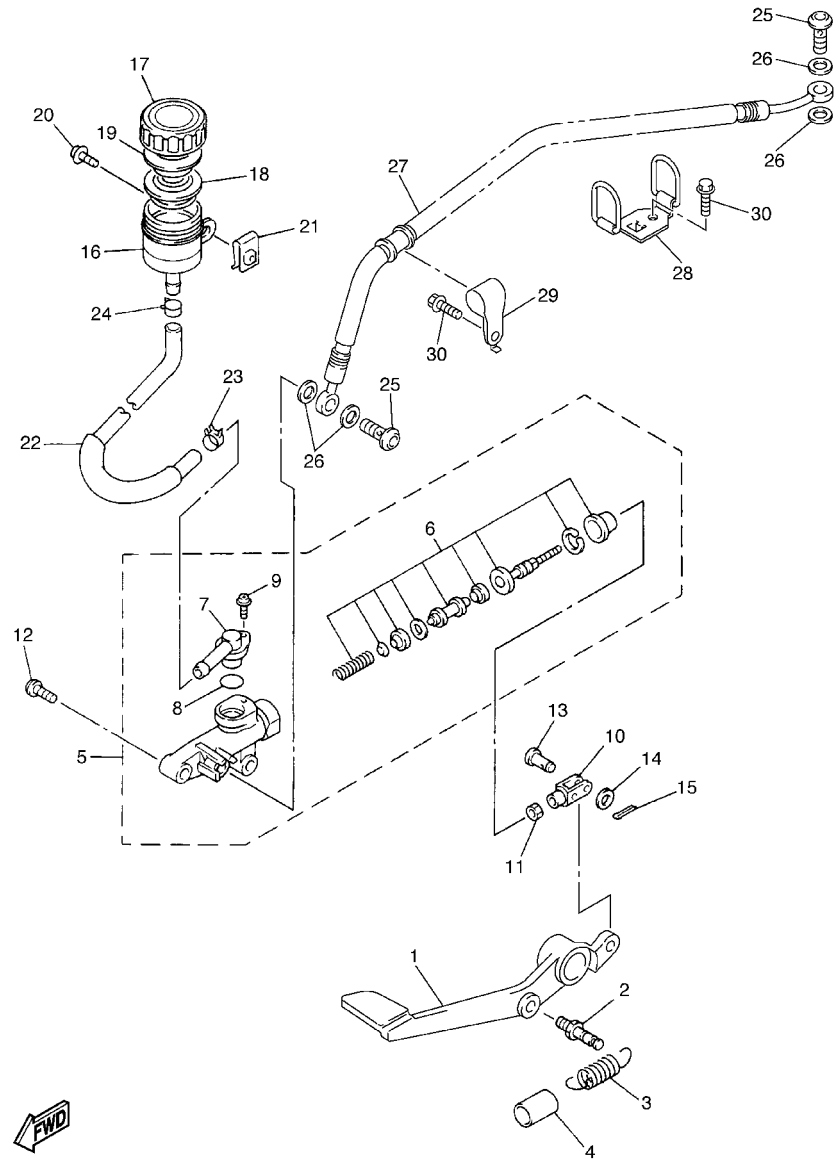



5PW1300-2360

FIG. 36 REAR MASTER CYLINDER

REF. NO.	PART NO.	DESCRIPTION	5PW7				REMARKS
28	5PW-25886-00	HOLDER, BRAKE HOSE	1				
29	5EB-25886-01	HOLDER, BRAKE HOSE	1				
30	90105-06718	BOLT, FLANGE	2				

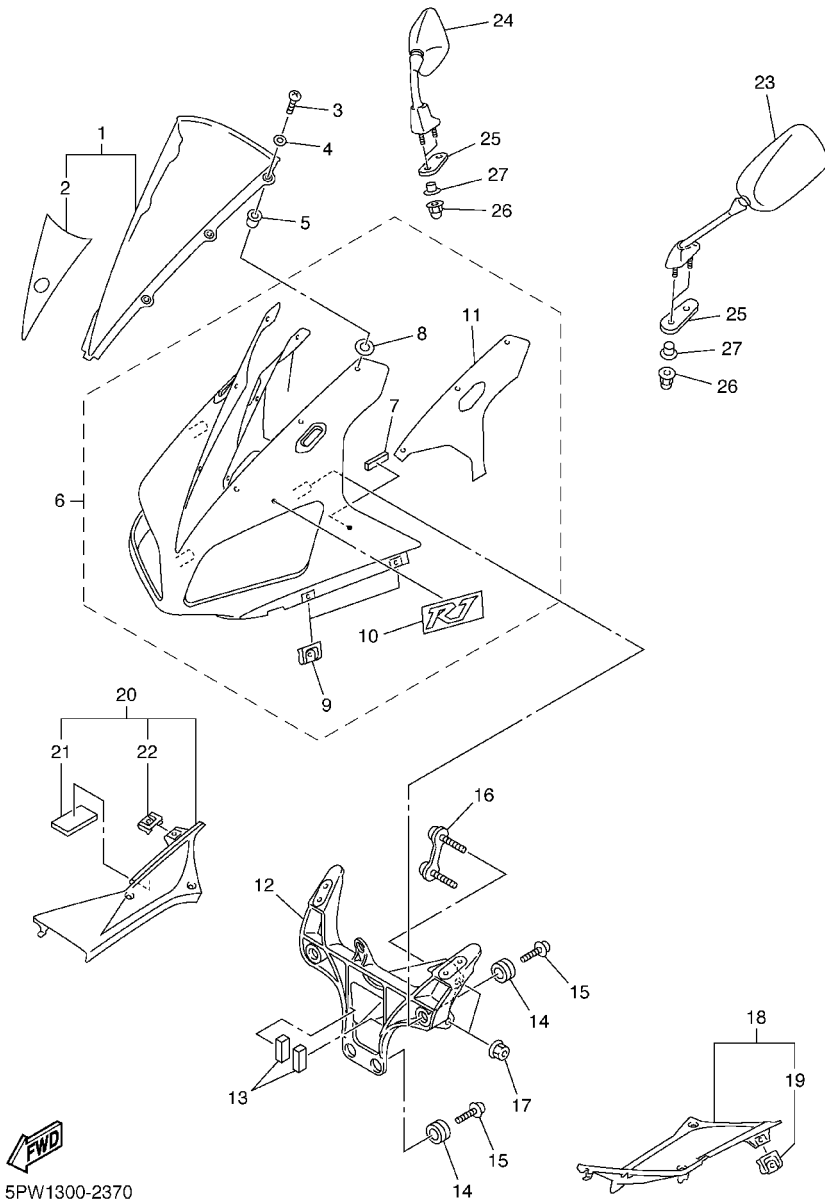
FIG. 37 COWLING 1



5PW1300-2370

REF. NO.	PART NO.	DESCRIPTION	5PW7				REMARKS
1	5PW-Y2881-00	WINDSHIELD	1				
2	5PW-2832P-10	.GRAPHIC 18	1				
3	90150-05024	SCREW, ROUND HEAD	6				
4	90202-05123	WASHER, PLATE	6				
5	90179-05523	NUT	6				
6	5PW-Y283G-00-P0	BODY, FRONT UPPER 1	1				VRC1
	5PW-Y283G-10-P1	BODY, FRONT UPPER 1	1				DPBMC
	5PW-Y283G-20-P2	BODY, FRONT UPPER 1	1				S3
7	1HX-27415-00	.PLATE, FOOTREST	2				
8	5JJ-2834W-00	.PROTECTOR 2	6				
9	5PW-2177L-00	.PLATE, SPRING	4				
10	5PW-28315-01	.EMBLEM	1				FOR VRC1
	5PW-28315-11	.EMBLEM	1				FOR DPBMC
	5PW-28315-21	.EMBLEM	1				FOR S3
11	5PW-283A0-00	.GRAPHIC SET	1				
12	5PW-28356-00	STAY 1	1				
13	5DM-28371-00	DAMPER	2				
14	4XV-83513-00	DAMPER	4				
15	90164-05014	SCREW, TAPPING	4				
16	4XV-28336-00	PLATE	1				
17	95607-08200	NUT, SELF-LOCKING	2				
18	5PW-Y283L-00-P0	PANEL, CONSOLE 1	1				MBL2
19	5PW-2177L-00	.PLATE, SPRING	1				
20	5PW-Y283M-00-P0	PANEL, CONSOLE 2	1				MBL2
21	1TX-28371-00	.DAMPER	1				
22	5PW-2177L-00	.PLATE, SPRING	1				
23	5PW-26280-00	REAR VIEW MIRROR ASSY (LEFT)	1				

FIG. 38 COWLING 2

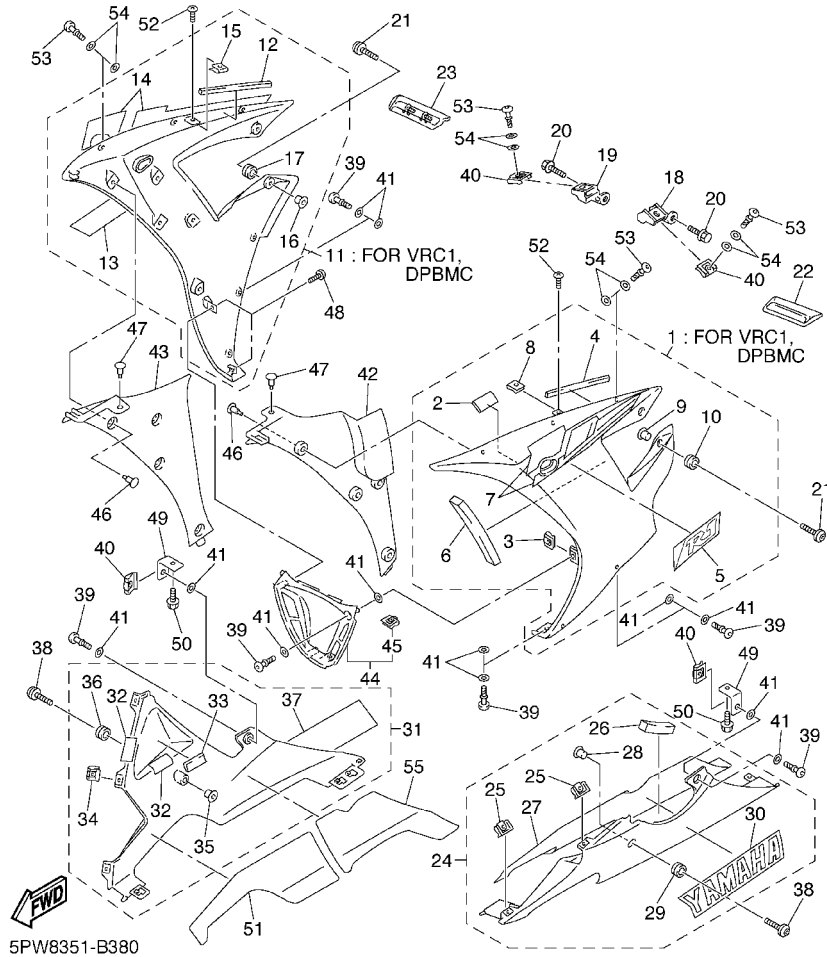
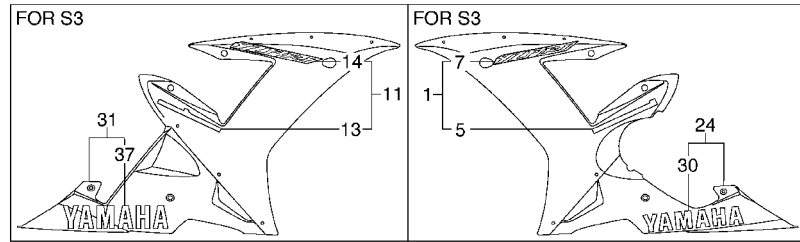

REF. NO.	PART NO.	DESCRIPTION	5PW7	REMARKS
1	5PW-Y283U-50-P2	PANEL ASSEMBLY 1	1	FOR VRC1
	5PW-Y283U-60-P1	PANEL ASSEMBLY 1	1	FOR DPBMC
	5PW-Y283U-70-P2	PANEL ASSEMBLY 1	1	FOR S3
2	1TX-28371-00	.DAMPER	1	
3	5PW-2177L-00	.PLATE, SPRING	1	
4	5PW-28307-00	.SEAL	1	
5	5PW-2834C-00	.EMBLEM 1	1	FOR VRC1
	5PW-2834C-10	.EMBLEM 1	1	FOR DPBMC
	5PW-28328-21	.EMBLEM	1	FOR S3
6	5PW-28371-00	.DAMPER	1	
7	5PW-283B1-00	.GRAPHIC SET	1	FOR VRC1
	5PW-283B1-10	.GRAPHIC SET	1	FOR DPBMC
	5PW-2836C-01	.EMBLEM	1	FOR S3
8	90183-05074	.NUT, SPRING	1	
9	90387-065J6	.COLLAR	2	
10	90480-12596	.GROMMET	2	
11	5PW-Y283V-50-P2	PANEL ASSEMBLY 2	1	FOR VRC1
	5PW-Y283V-60-P1	PANEL ASSEMBLY 2	1	FOR DPBMC
	5PW-Y283V-70-P2	PANEL ASSEMBLY 2	1	FOR S3
12	5PW-28307-00	.SEAL	1	
13	5PW-2835C-00	.EMBLEM 2	1	FOR VRC1
	5PW-2835C-10	.EMBLEM 2	1	FOR DPBMC
	5PW-28338-21	.EMBLEM	1	FOR S3
14	5PW-283B2-00	.GRAPHIC SET	1	FOR VRC1
	5PW-283B2-10	.GRAPHIC SET	1	FOR DPBMC
	5PW-2836C-01	.EMBLEM	1	FOR S3
15	90183-05074	.NUT, SPRING	1	

FIG. 38 COWLING 2

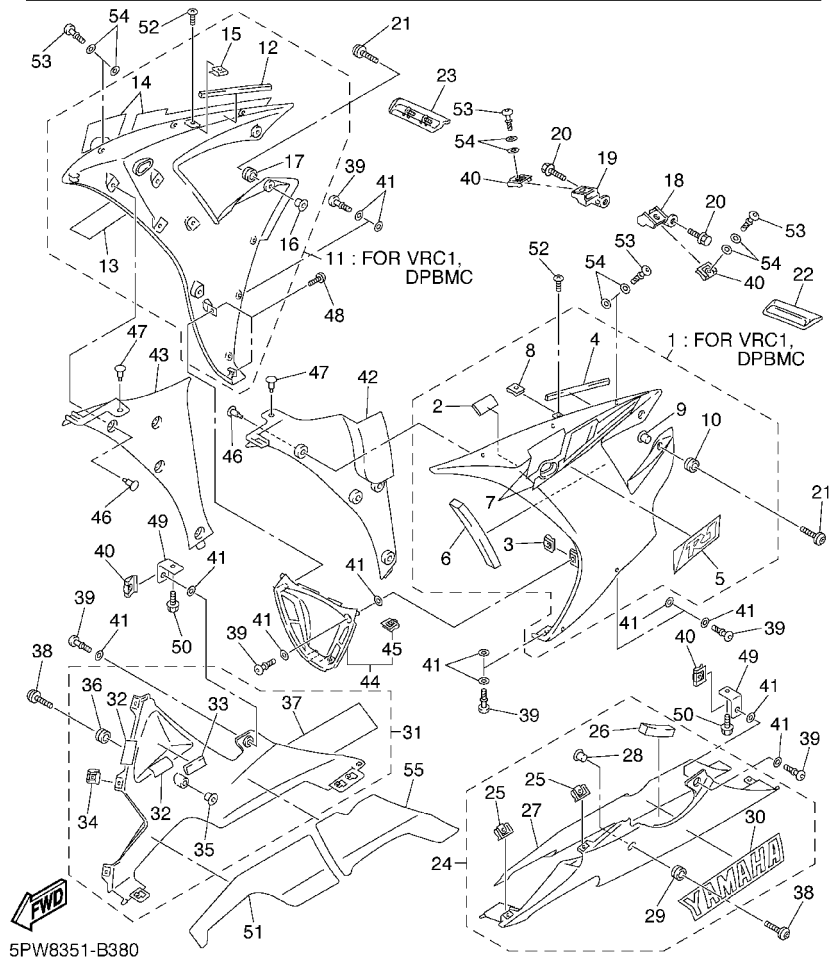
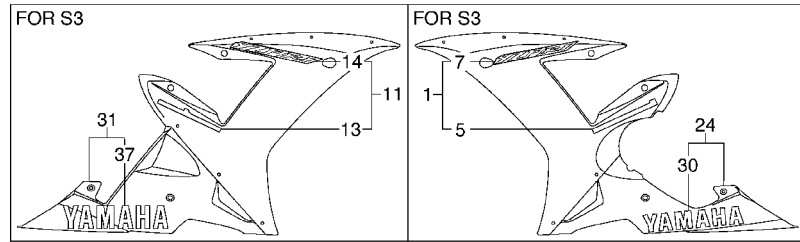

REF. NO.	PART NO.	DESCRIPTION	5PW7				REMARKS
16	90387-065J6	.COLLAR	2				
17	90480-12596	.GROMMET	2				
18	5PW-2836A-00	BRACKET 1	1				
19	5PW-2836E-00	BRACKET 2	1				
20	90119-06052	BOLT, WITH WASHER	2				
21	90149-06302	SCREW	4				
22	5PW-2832M-00	PROTECTOR 1	1				
23	5PW-2832N-00	PROTECTOR 2	1				
24	5PW-Y2808-00-P3	COVER, LOWER	1				FOR VRC1
	5PW-Y2808-00-P0	COVER, LOWER	1				FOR DPBMC
	5PW-Y2808-10-P1	COVER, LOWER	1				FOR S3
25	5PW-2177L-00	.PLATE, SPRING	2				
26	5PW-2834E-00	.DAMPER 1	1				
27	5PW-2848L-00	.SEAT 3	1				
28	90387-065J6	.COLLAR	1				
29	90480-12596	.GROMMET	1				
30	99247-00320	.EMBLEM, YAMAHA	1				FOR VRC1,S3
	99246-00320	.EMBLEM, YAMAHA	1				FOR DPBMC
31	5PW-Y2809-01-P3	COVER ASSY 2, UNDER	1				FOR VRC1
	5PW-Y2809-01-P0	COVER ASSY 2, UNDER	1				FOR DPBMC
	5PW-Y2809-11-P1	COVER ASSY 2, UNDER	1				FOR S3
32	1JK-21735-00	.SEAL 2	2				
33	1TX-28371-00	.DAMPER	1				
34	5PW-2177L-00	.PLATE, SPRING	3				
35	90387-065J6	.COLLAR	1				
36	90480-12596	.GROMMET	1				
37	99247-00320	.EMBLEM, YAMAHA	1				FOR VRC1,S3

FIG. 38 COWLING 2

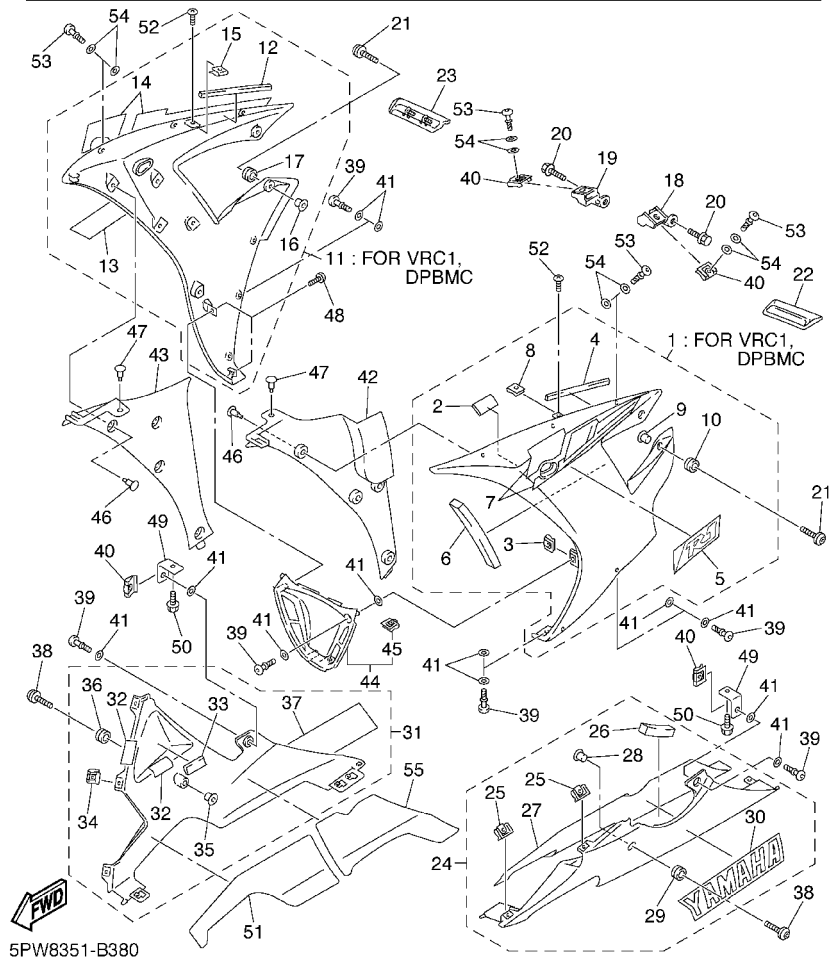
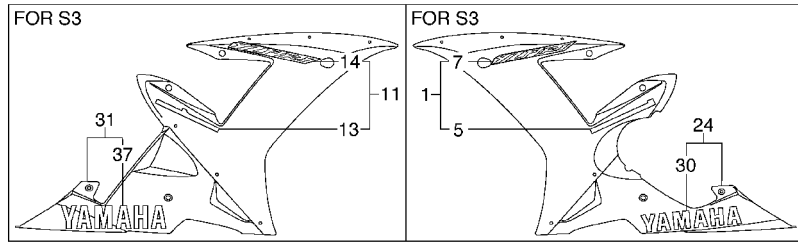

REF. NO.	PART NO.	DESCRIPTION	5PW7				REMARKS
37	99246-00320	.EMBLEM, YAMAHA	1				FOR DPBMC
38	90149-06302	SCREW	2				
39	5PW-28386-00	HEAD	9				
40	5PW-2177L-00	PLATE, SPRING	4				
41	2TK-21757-00	WASHER, SPECIAL 1	18				
42	5PW-2836K-00	PANEL, INNER 1	1				
43	5PW-2836L-00	PANEL, INNER 2	1				
44	5PW-Y283S-00	PANEL, INNER 3	1				
45	5PW-2177L-00	.PLATE, SPRING	1				
46	90269-06081	RIVET	8				
47	90269-07077	RIVET	2				
48	97707-50016	SCREW, TAPPING	2				
49	5PW-2836F-00	BRACKET 3	2				
50	95807-06012	BOLT, FLANGE	2				
51	5PW-2848M-00	SEAT 4	1				
52	90154-05013	SCREW, BINDING	2				
53	5PW-28386-00	HEAD	8				
54	2TK-21757-00	WASHER, SPECIAL 1	12				
55	5PW-2848N-00	SEAT 5	1				

FIG. 40 STARTING MOTOR

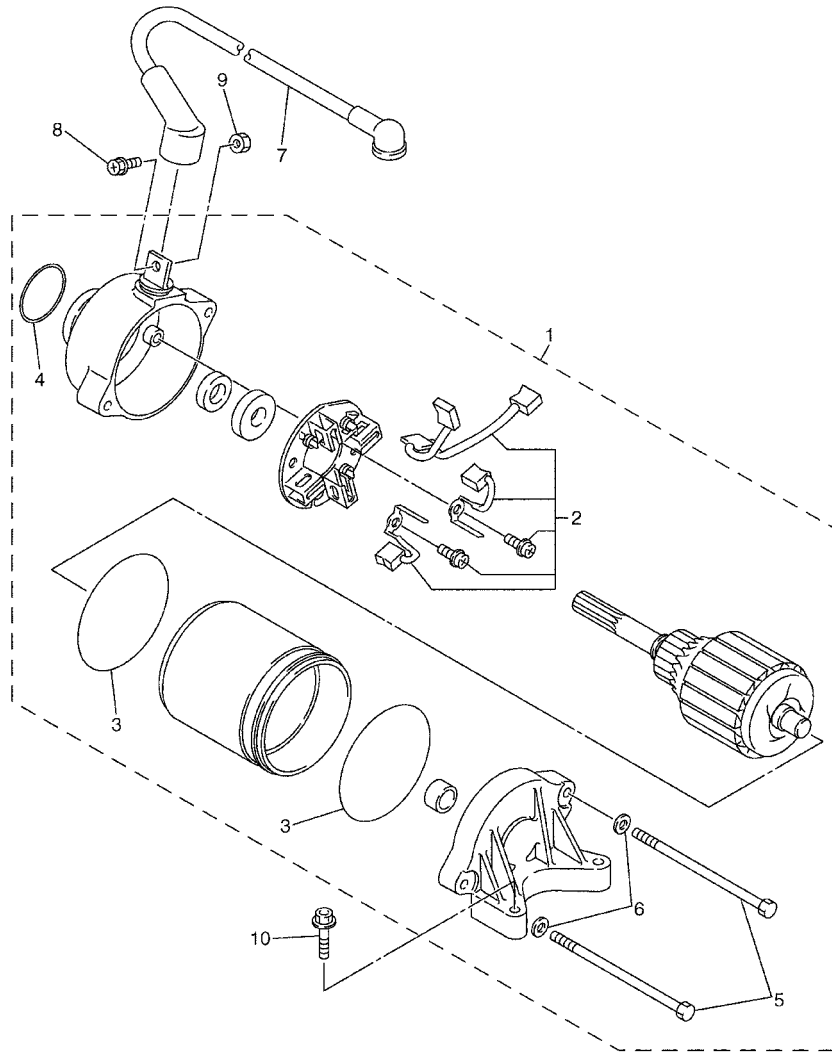

REF. NO.	PART NO.	DESCRIPTION	5PW7				REMARKS
1	5PW-81890-01	MOTOR ASSY	1				
2	5PW-81801-00	.BRUSH SET	1				
3	93210-55669	.O-RING	2				
4	93210-25711	.O-RING	1				
5	5PW-81846-00	.SCREW	2				
6	5PW-8181L-00	.WASHER, PLAIN	2				
7	5PW-8183G-00	CORD COMP.	1				
8	5PW-81828-00	BOLT 2	1				
9	95380-05700	NUT	1				
10	95027-06025	BOLT, FLANGE	2				

5PW1300-2400

FIG. 41 FLASHER LIGHT

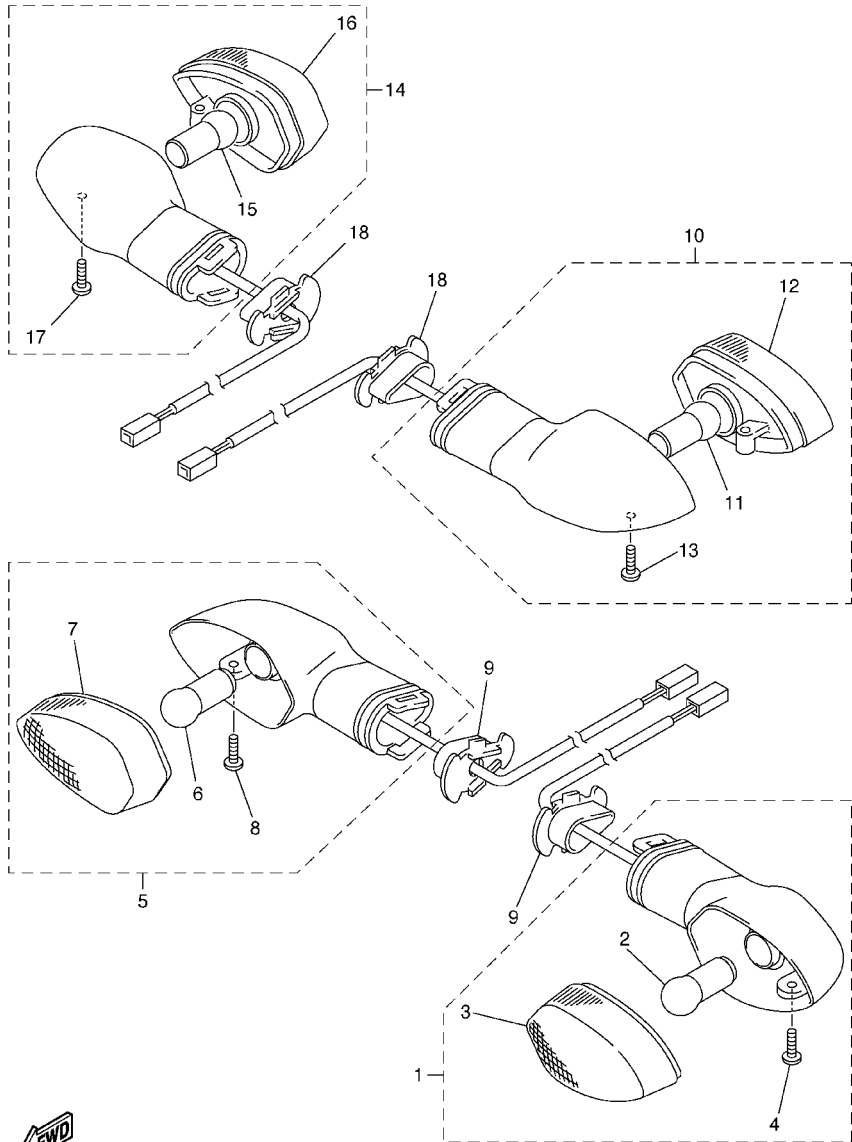

5PW1300-2410

REF. NO.	PART NO.	DESCRIPTION	5PW7				REMARKS
1	5PW-83310-01	FRONT FLASHER LIGHT ASSY 1	1				
2	1KH-83311-00	.BULB (12V-10W)	1				
3	5PW-8333A-00	.LENS COMP	1				
4	97706-04012	.SCREW, TAPPING	1				
5	5PW-83320-01	FRONT FLASHER LIGHT ASSY 2	1				
6	1KH-83311-00	.BULB (12V-10W)	1				
7	5PW-8334A-00	.LENS COMP	1				
8	97706-04012	.SCREW, TAPPING	1				
9	5PW-83318-00	STAY, FLASHER 1	2				
10	5PW-83330-00	REAR FLASHER LIGHT ASSY 1	1				
11	1KH-83311-00	.BULB (12V-10W)	1				
12	5PW-8334A-00	.LENS COMP	1				
13	97706-04012	.SCREW, TAPPING	1				
14	5PW-83340-00	FLASHER LIGHT ASSY 2	1				
15	1KH-83311-00	.BULB (12V-10W)	1				
16	5PW-8333A-00	.LENS COMP	1				
17	97706-04012	.SCREW, TAPPING	1				
18	5PW-83318-00	STAY, FLASHER 1	2				

FIG. 42 METER

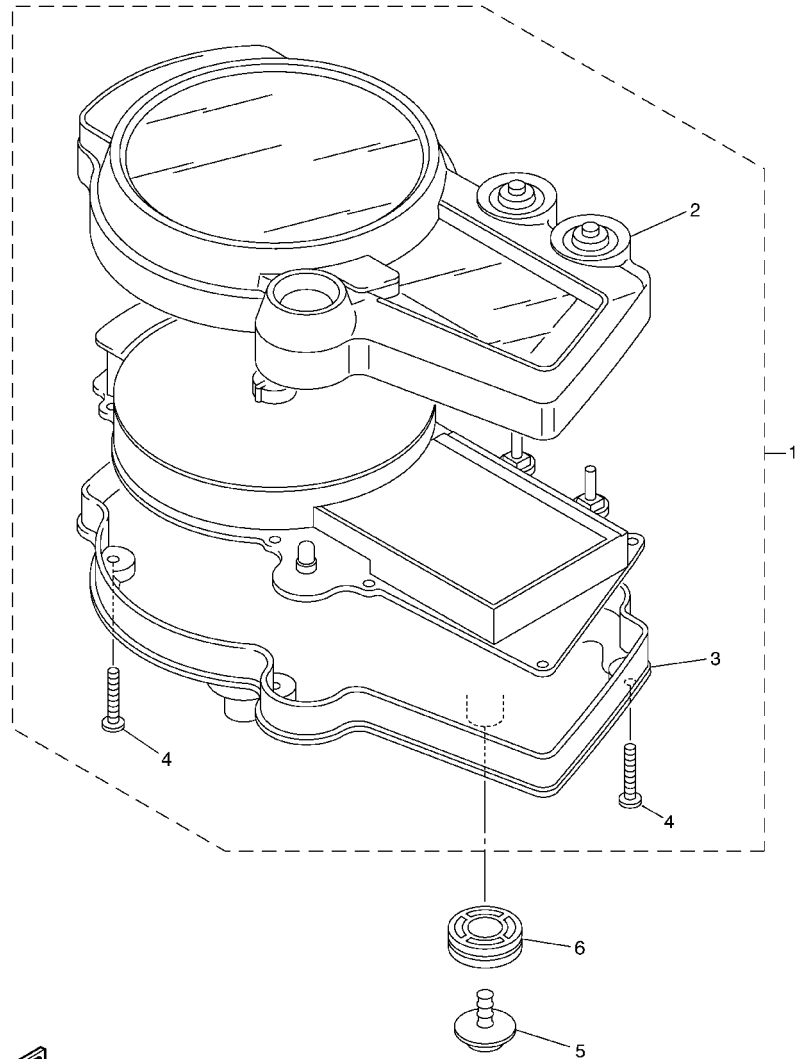

REF. NO.	PART NO.	DESCRIPTION	5PW7				REMARKS
1	5PW-83500-00	SPEEDOMETER ASSY (KM/H)	1				
	5PW-83500-10	SPEEDOMETER ASSY (MPH)	1				FOR GBR
2	5PW-8353E-00	.CASE, METER UPPER	1				
3	5PW-83572-00	.CASE, SPEEDOMETER LOWER	1				
4	5PW-8352S-00	.SCREW, PANEL FTING	8				
5	90164-05014	SCREW, TAPPING	3				
6	4XV-83513-00	DAMPER	3				

 5PW1300-2420

FIG. 43 HEADLIGHT

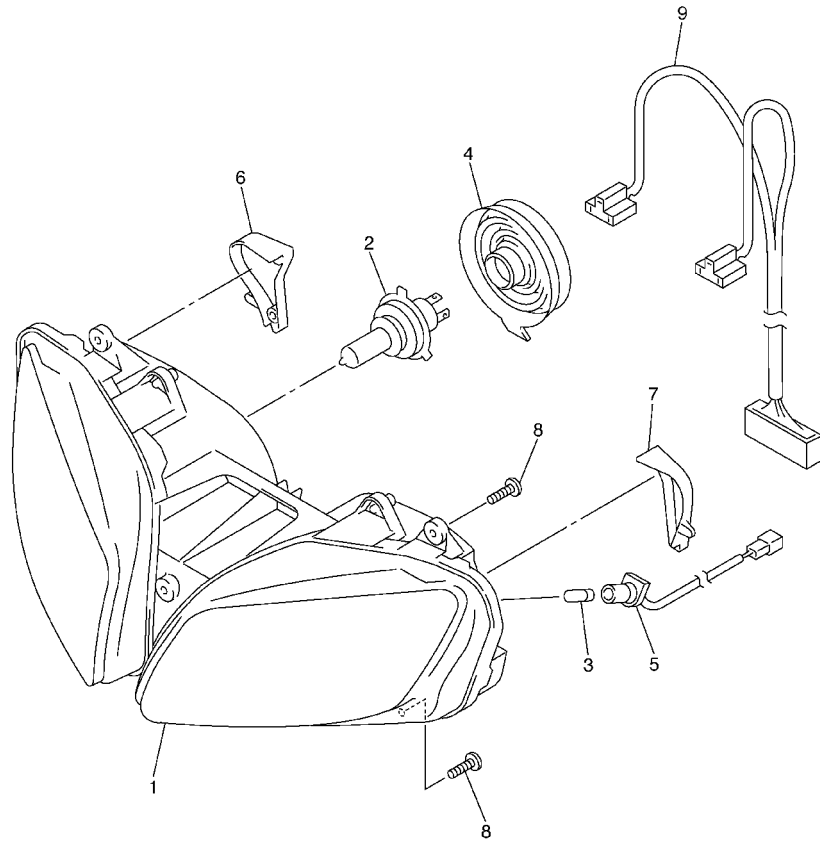

REF. NO.	PART NO.	DESCRIPTION	5PW7				REMARKS
1	5PW-84310-00	HEADLIGHT UNIT ASSY	1				
	5PW-84310-10	HEADLIGHT UNIT ASSY	1				FOR GBR,ZAF
2	8V0-84314-10	BULB,HEADLIGHT (12V-60/55W)	2				
3	4SV-84347-00	BULB (12V-5W)	2				
4	4SV-84397-00	COVER, SOCKET	2				
5	5PW-84312-00	HOLDER, SOCKET	2				
6	5PW-84385-00	CAP,1	1				
7	5PW-84386-00	CAP,2	1				
8	97707-50016	SCREW, TAPPING	5				
9	5PW-84359-11	CORD, HEADLIGHT	1				



5PW1300-2430

FIG. 44 TAILLIGHT

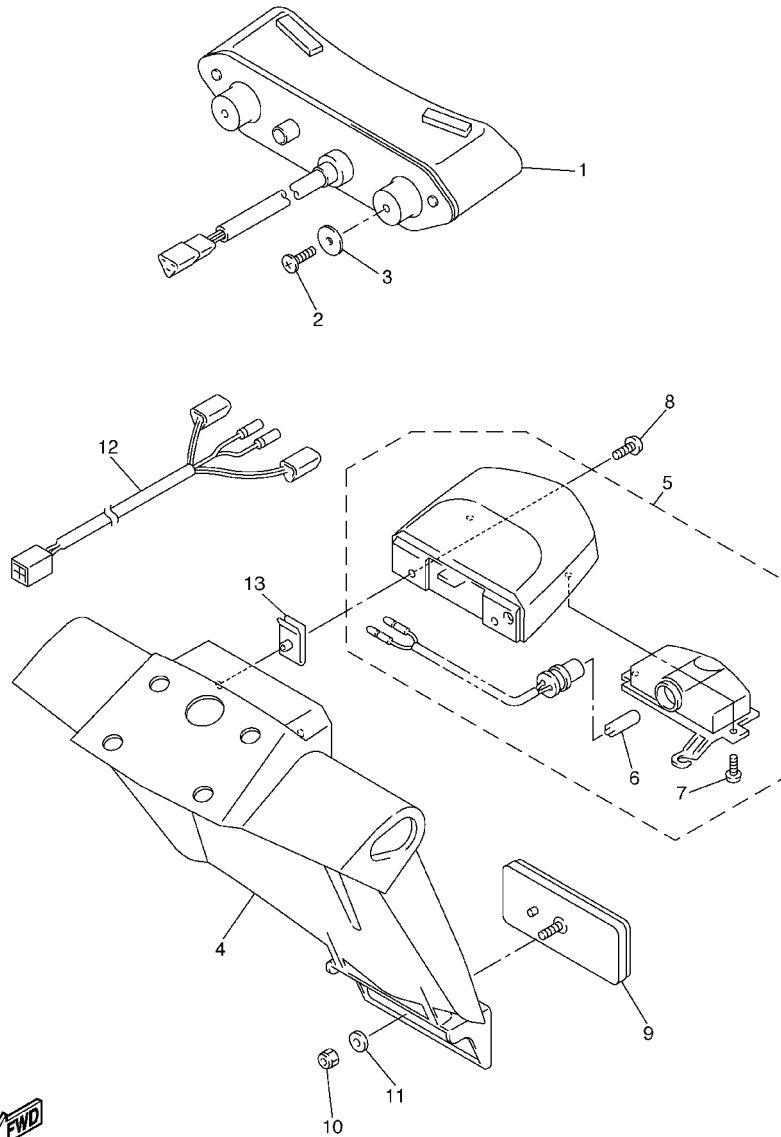

REF. NO.	PART NO.	DESCRIPTION	5PW7				REMARKS
1	5PW-84710-00	TAILLIGHT UNIT ASSY	1				
2	97707-50016	SCREW, TAPPING	2				
3	90201-05033	WASHER, PLATE	2				
4	5PW-21629-00	GUARD, MUD	1				
5	5PW-84745-00	LICENCE LIGHT UNIT ASSY	1				
6	4HC-84744-00	.BULB (12V-5W)	1				
7	97706-04012	.SCREW, TAPPING	2				
8	5PW-84726-00	SCREW	2				
9	3Y6-85130-02	REAR REFLECTOR ASSY	1				
10	95607-05100	NUT, U	1				
11	90201-05725	WASHER, PLATE	1				
12	5PW-84717-00	CORD, TAILLIGHT	1				
13	4KB-84117-00	NUT	2				



5PW1300-2440

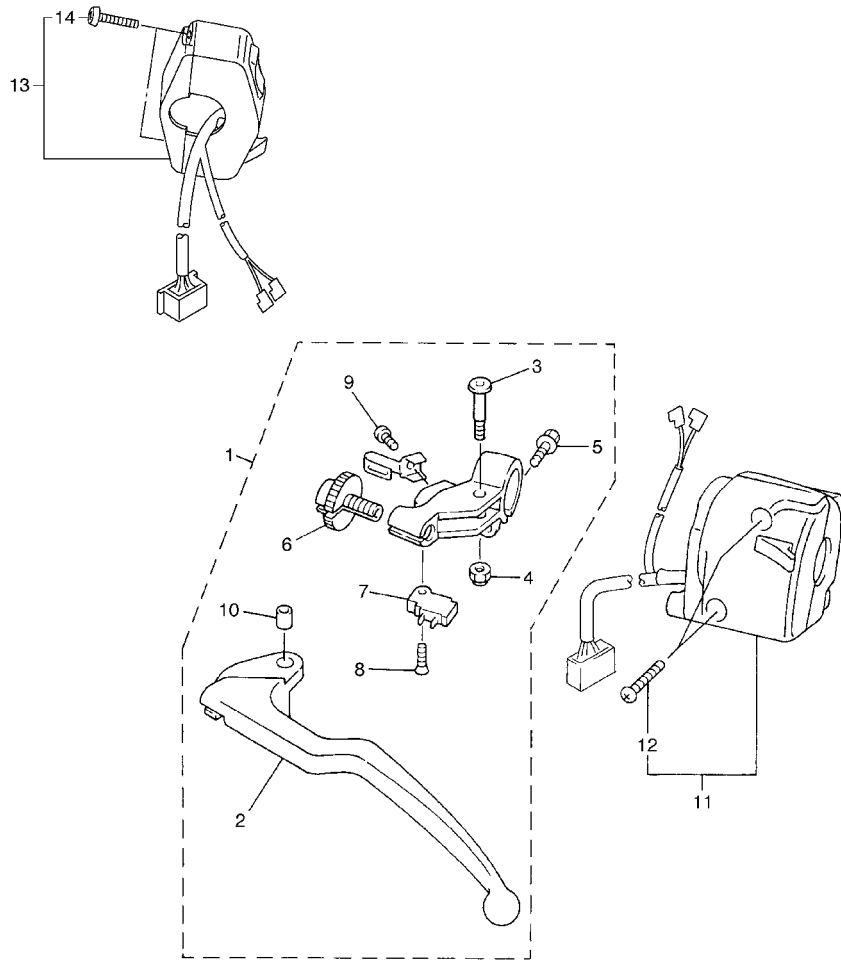
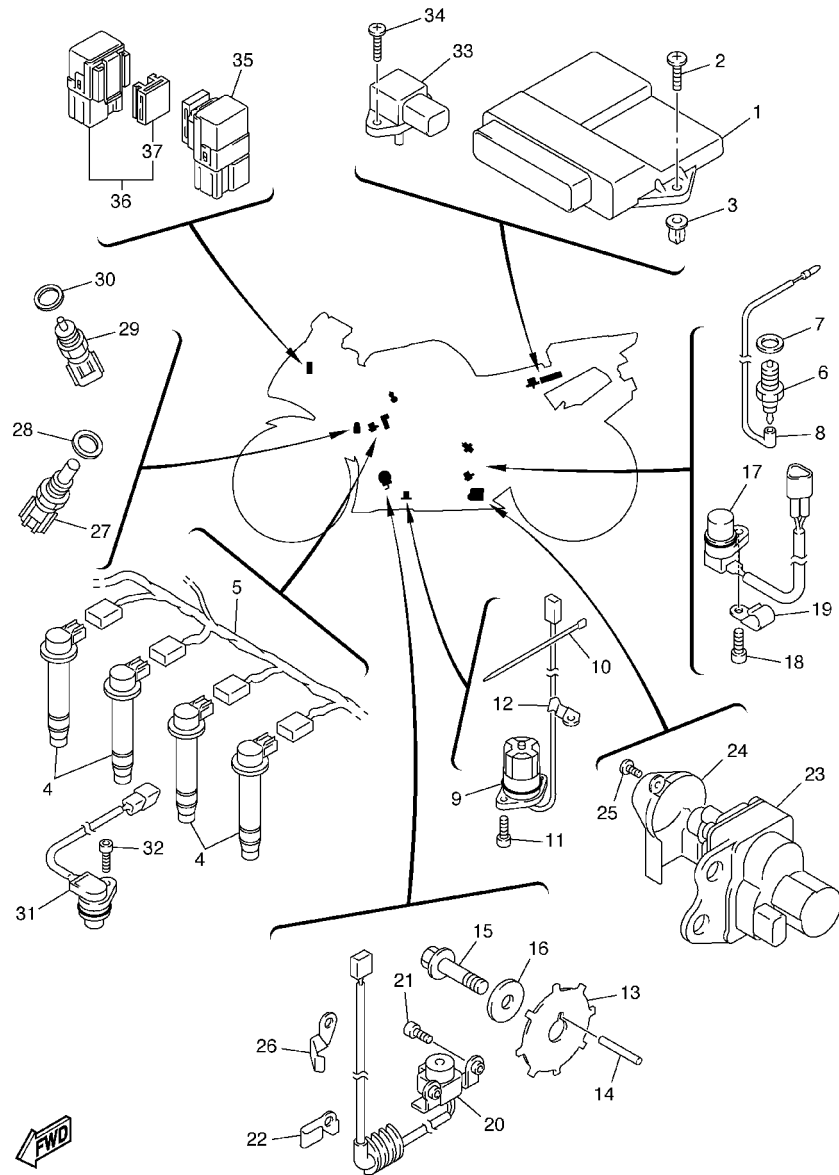

FIG. 45 HANDLE SWITCH. LEVER

REF. NO.	PART NO.	DESCRIPTION	5PW7				REMARKS
1	4XV-82910-13	LEVER HOLDER ASSY (LEFT)	1				
2	4XV-83912-11	.LEVER 1	1				
3	4XV-83945-00	.BOLT, LEVER	1				
4	95607-06100	.NUT, U	1				
5	95027-06020	.BOLT, FLANGE	1				
6	5LV-83951-00	.BOLT, CABLE ADJUSTING	1				
7	4XV-82917-01	.SWITCH	1				
8	98707-03016	.SCREW, FLAT HEAD	1				
9	98507-04010	.SCREW	1				
10	5JJ-83913-00	.COLLAR, LEVER 1	1				
11	5PW-83969-00	SWITCH, HANDLE 5	1				
12	98507-05025	.SCREW, PAN HEAD	2				
13	5PW-83975-00	SWITCH, HANDLE 2	1				
14	98507-05022	.SCREW, PAN HEAD	2				

 5PW8351-B450

FIG. 46 ELECTRICAL 1



PWD
5PW8351-B460

REF. NO.	PART NO.	DESCRIPTION	5PW7				REMARKS
1	5PW-8591A-41	ENGINE CONTROL UNIT ASSY	1				
2	97707-60020	SCREW, TAPPING	2				
3	90338-08226	PLUG	2				
4	5PW-82310-00	IGNITION COIL ASSY	4				
5	5PW-82309-00	WIRE, SUB LEAD	1				
6	3GB-82540-01	NEUTRAL SWITCH ASSY	1				
7	90430-10148	GASKET	1				
8	5JJ-82541-00	WIRE, LEAD	1				
9	5PW-85720-00	OIL LEVEL GAUGE ASSY	1				
10	5Y9-12491-00	CLAMP 1	1				
11	91317-06014	BOLT	2				
12	90465-08013	CLAMP	1				
13	5PW-81673-00	ROTOR	1				
14	93604-29151	PIN, DOWEL	1				
15	90105-10290	BOLT, FLANGE	1				
16	90201-107K6	WASHER, PLATE	1				
17	4XV-83755-01	SENSOR, SPEED	1				
18	91317-06014	BOLT	1				
19	90465-08028	CLAMP	1				
20	5PW-81670-00	PICK-UP ASSY	1				
21	90110-06018	BOLT, HEXAGON SOCKET HEAD	2				
22	90465-08191	CLAMP	1				
23	5PW-85820-00	SERVO MOTOR ASSY	1				
24	5PW-85829-00	COVER, SERVO MOTOR	1				
25	97707-50514	SCREW, TAPPING	2				
26	90462-08225	CLAMP	1				
27	8CC-85790-01	THERMOSENSOR ASSY	1				

FIG. 46 ELECTRICAL 1

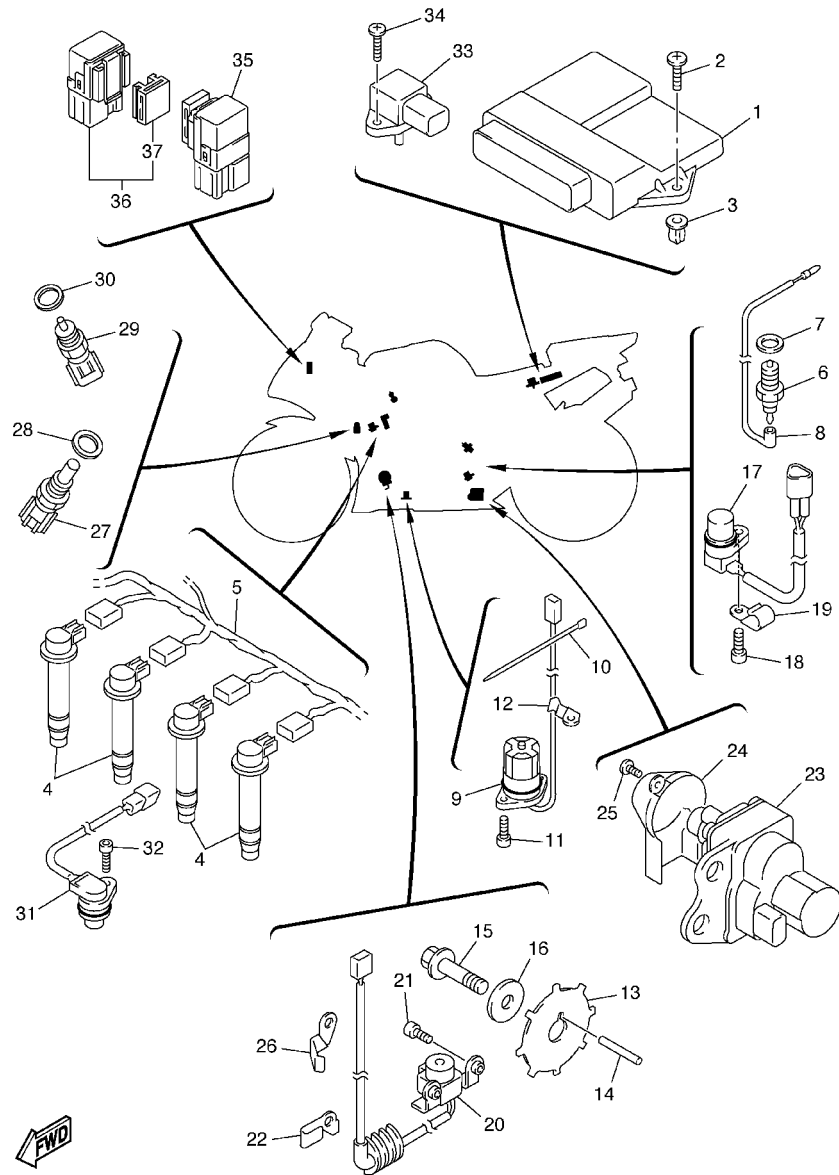

5PW8351-B460

REF. NO.	PART NO.	DESCRIPTION	5PW7				REMARKS
28	90201-12790	WASHER, PLATE	1				
29	5FL-85790-00	THERMOSENSOR ASSY	1				
30	90430-12202	GASKET	1				
31	5PW-85896-00	SENSOR, CAM POSITION	1				
32	90110-06019	BOLT, HEXAGON SOCKET HEAD	1				
33	5JW-82380-00	SENSOR, PRESSURE	1				
34	97707-50020	SCREW, TAPPING	2				
35	5JJ-81950-10	RELAY ASSY	1				
36	5JJ-81950-20	RELAY ASSY	1				
37	5JJ-81952-00	.HOLDER, RELAY	1				

FIG. 47 ELECTRICAL 2

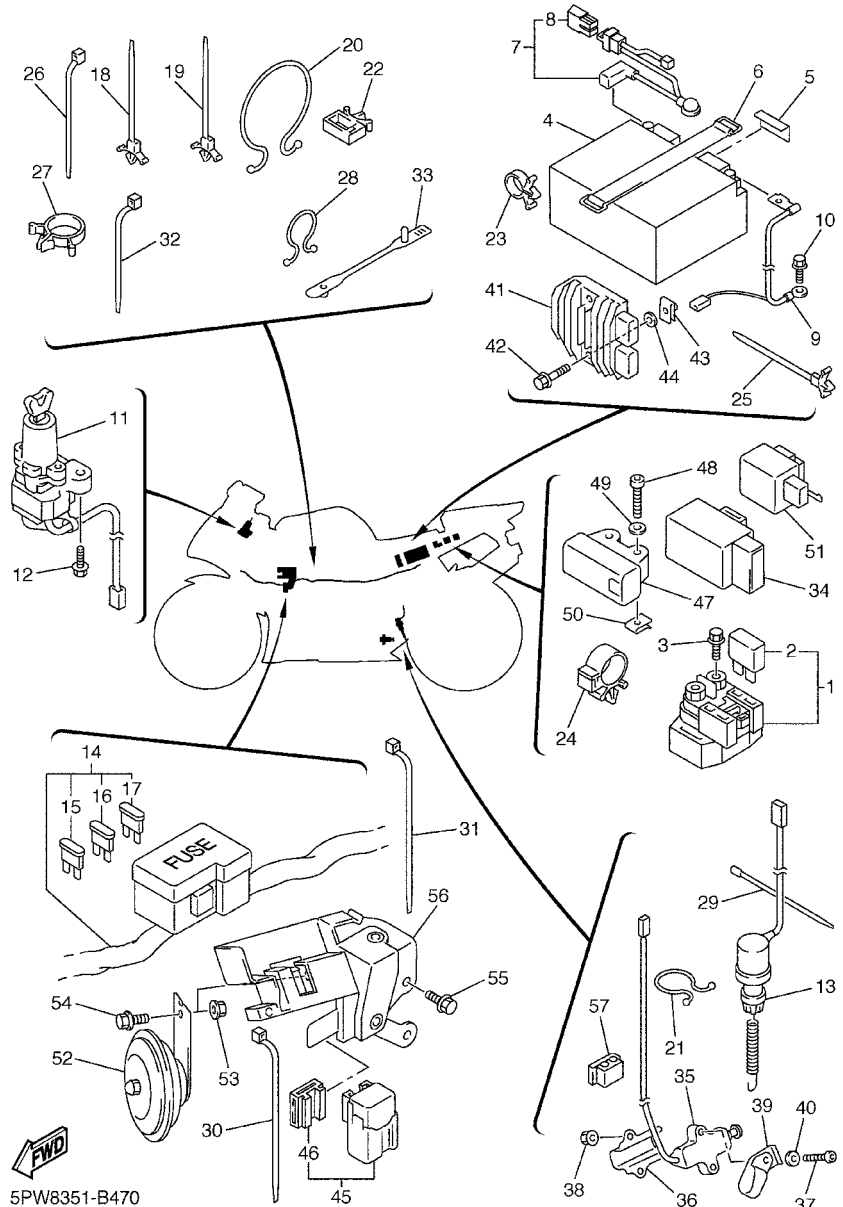

5PW8351-B470

REF. NO.	PART NO.	DESCRIPTION	5PW7				REMARKS
1	5JW-81940-00	STARTER RELAY ASSY	1				
2	36Y-82151-00	.FUSE (15A-BL)	2				
3	95027-06008	BOLT, FLANGE	2				
4	4TX-82100-02	BATTERY ASSY (GS GT12B-4)	1				
5	2AL-84553-00	DAMPER	1				
6	5JJ-82131-00	BAND, BATTERY	1				
7	5PW-82115-00	WIRE, PLUS LEAD	1				
8	5JW-82151-10	.FUSE (50A)	1				
9	5PW-82116-00	WIRE, MINUS LEAD	1				
10	95817-06012	BOLT, FLANGE	1				
11	5PW-82501-20	MAIN SWITCH STEERING LOCK	1				
12	90109-080G5	BOLT	2				
13	5PW-82530-00	STOP SWITCH ASSY	1				
14	5PW-82590-20	WIRE HARNESS ASSY	1				
15	5JJ-82151-10	.FUSE (15A-BL)	3				
16	5JJ-82151-30	.FUSE (10A-BL)	4				
17	5JJ-82151-20	.FUSE (20A-BL)	2				
18	90464-12036	CLAMP	2				
19	90464-12036	CLAMP	2				
20	90464-37257	CLAMP	1				
21	90464-16039	CLAMP	1				
22	90464-07004	CLAMP	3				
23	90464-13133	CLAMP	2				
24	90464-16006	CLAMP	1				
25	90464-12036	CLAMP	1				
26	90464-13073	CLAMP	1				
27	90464-15157	CLAMP	2				

FIG. 47 ELECTRICAL 2

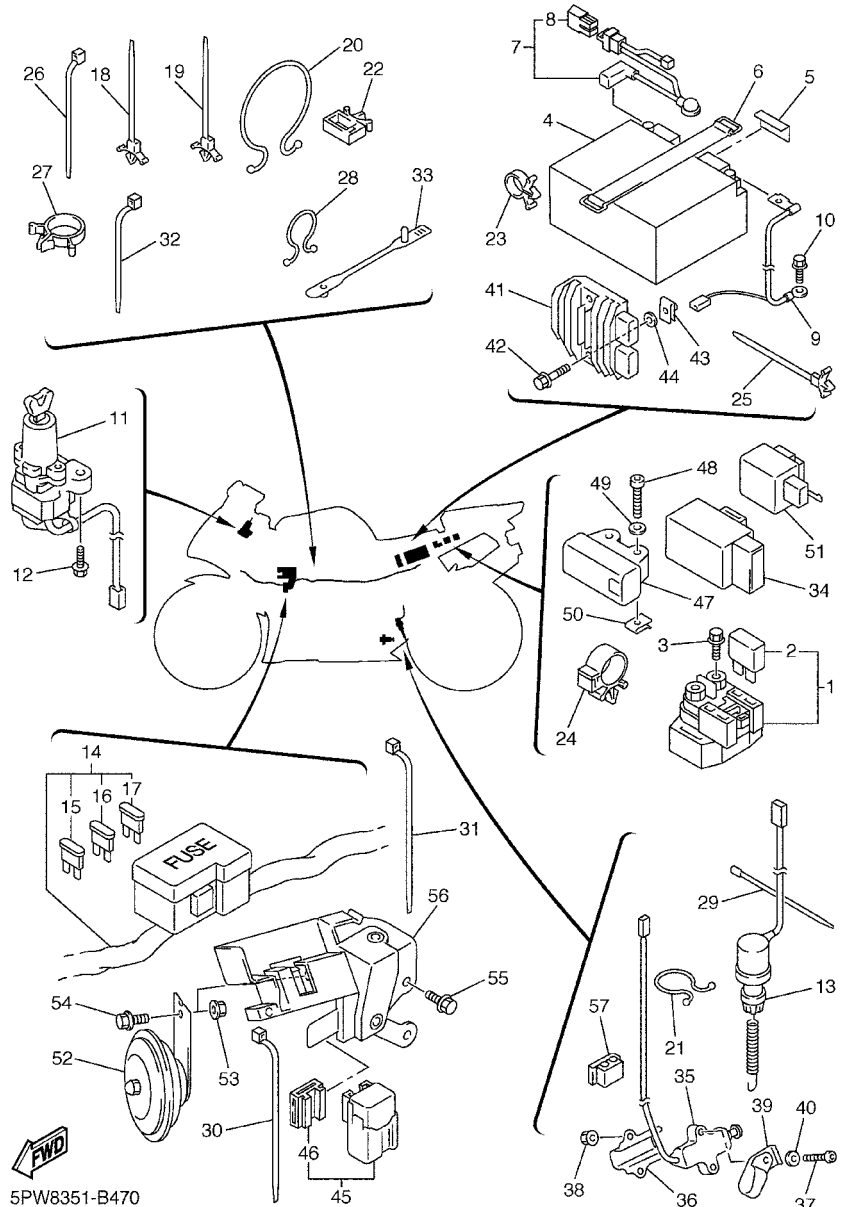

5PW8351-B470

REF. NO.	PART NO.	DESCRIPTION	5PW7				REMARKS
28	90464-16039	CLAMP	1				
29	5Y9-12491-00	CLAMP 1	1				
30	90464-13073	CLAMP	1				
31	90464-13073	CLAMP	1				
32	90464-13077	CLAMP	1				
33	90464-17001	CLAMP	1				
34	5PW-81950-00	RELAY ASSY	1				
35	5PX-82566-50	SWITCH, SIDE STAND	1				
36	5JJ-82388-00	PLATE	1				
37	92017-05030	BOLT	2				
38	95607-05200	NUT, U FLANGE	2				
39	90461-10002	CLAMP	1				
40	90201-057H5	WASHER, PLATE	1				
41	5JW-81960-00	RECTIFIER & REGULATOR ASSY	1				
42	95827-06030	BOLT, FLANGE	2				
43	90183-06053	NUT, SPRING	2				
44	90202-06001	WASHER, PLATE	2				
45	5JJ-81950-20	RELAY ASSY	1				
46	5JJ-81952-00	.HOLDER, RELAY	1				
47	5PS-82576-01	EMERGENCY STOP SWITCH ASSY	1				
48	91317-04025	BOLT	2				
49	90201-047A2	WASHER, PLATE	2				
50	90183-04039	NUT, SPRING	2				
51	4GY-83350-00	FLASHER RELAY ASSY	1				
52	3TB-83371-01	HORN	1				
53	95707-06500	NUT, FLANGĒ	1				
54	95807-06012	BOLT, FLANGE	1				

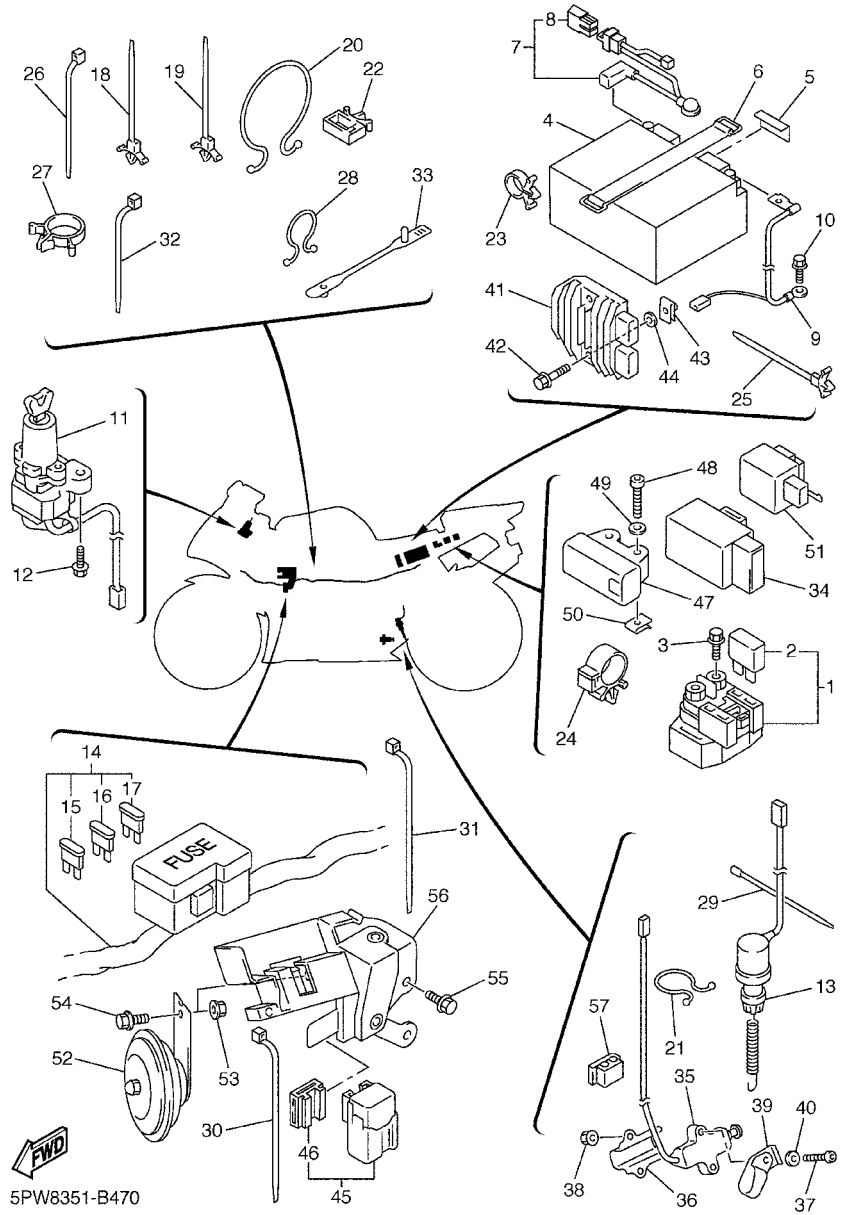

FIG. 47 ELECTRICAL 2

REF. NO.	PART NO.	DESCRIPTION	5PW7				REMARKS
55	95807-06012	BOLT, FLANGE	2				
56	5PW-2134K-00	BRACKET, HORN	1				
57	90464-06004	CLAMP	1				

NUMERICAL INDEX

PART NO.	GRID NO.	PART NO.	GRID NO.	PART NO.	GRID NO.	PART NO.	GRID NO.	PART NO.	GRID NO.	PART NO.	GRID NO.
4SV-W0041-00	E - 7	4XV-11411-00	B - 3	1HX-12169-E0	B - 5	5PW-12588-00	B - 10	5PW-14396-00	B - 14	5PW-15416-00	C - 6
3TU-W0042-51	E - 12	3GM-11416-A0	B - 3	1HX-12169-G0	B - 5	5PW-12589-00	B - 10	5PW-14401-00	B - 13	5PW-15418-00	C - 6
5PW-W0045-00	E - 2	3GM-11416-B0	B - 3	1HX-12169-J0	B - 5	5PW-12822-00	B - 12	5JJ-14414-00	B - 13	5PW-15421-01	C - 6
5PW-W0046-50	E - 5	3GM-11416-00	B - 3	1HX-12169-L0	B - 5	5JW-12881-00	B - 14	5PW-14437-00	B - 13	5PW-15425-00	C - 6
4JG-W0047-00	E - 5	3GM-11416-10	B - 3	1HX-12169-N0	B - 5	5JJ-1316E-00	B - 11	5PW-14451-00	B - 13	4XV-15441-00	C - 7
5PW-W0047-00	E - 2	3GM-11416-20	B - 3	1HX-12169-T0	B - 5	5PW-13161-00	B - 12	4XV-14452-00	B - 13	5PW-15451-00	C - 6
5PW-W0047-10	E - 2	4XV-11549-00	B - 3	1HX-12169-11	B - 5	4XV-13310-00	B - 7	5PW-14453-00	B - 13	5JJ-15456-00	C - 6
1J3-W0048-00	E - 2	5LV-11603-00	B - 3	1HX-12169-31	B - 5	5PW-13318-00	B - 12	5JW-14589-00	B - 14	5PW-15461-00	C - 6
51L-W0048-00	E - 5	4XV-11631-10	B - 3	1HX-12169-50	B - 5	5PW-13327-01	B - 11	5PW-14602-01	C - 3	5JJ-15463-00	C - 6
4JG-W0057-00	E - 5	4XV-11633-00	B - 3	1HX-12169-70	B - 5	4XV-13336-00	B - 7	5PW-14610-01	C - 3	5PW-15515-00	C - 8
5PW-W0057-00	E - 2	5PW-11650-00	B - 3	1HX-12169-90	B - 5	5PW-13354-01	C - 10	4FM-14613-00	C - 4	5JJ-15517-00	C - 8
5PW-W0057-10	E - 2	5JW-11654-00	B - 3	5JJ-12171-00	B - 6	4XV-13355-00	B - 7	5PW-14623-00	C - 3	4XV-15521-00	C - 8
2TV-W2470-00	D - 14	3GM-11656-A0	B - 3	4XV-12176-00	B - 6	4XV-13411-00	B - 11	5PW-14638-01	C - 3	4XV-15570-00	C - 8
4SV-W2587-10	E - 7	3GM-11656-B0	B - 3	5PW-12181-00	B - 6	5PW-13412-00	B - 11	5PW-14643-00	C - 3	5PW-16150-00	C - 9
5PW-YK241-M0-P0	D - 12	3GM-11656-00	B - 3	5PW-12210-00	B - 6	5LV-13414-00	B - 12	5PW-14683-00	C - 3	26H-16154-00	C - 9
5PW-YK241-30-P0	D - 12	3GM-11656-10	B - 3	4FM-12213-00	B - 6	4XV-13416-00	B - 12	5PW-14684-00	C - 3	4XV-16154-00	C - 10
5PW-YK241-30-P1	D - 12	4XV-12111-00	B - 4	5BE-12241-00	B - 6	5PW-13417-00	B - 12	5PW-1469V-00	C - 3	341-16321-13	C - 9
5PW-Y2808-00-P0	F - 3	4XV-12112-00	B - 4	4XV-12251-00	B - 6	5GH-13440-00	B - 12	5PW-14710-00	C - 4	2H7-16325-00	C - 9
5PW-Y2808-00-P3	F - 3	4XV-12113-00	B - 4	5PW-12252-00	B - 6	5PW-13470-00	B - 12	4KM-14714-01	C - 2	4XV-16331-00	C - 9
5PW-Y2808-10-P1	F - 3	4XV-12114-00	B - 4	5PW-12405-00	B - 9	5PW-13473-00	B - 12	4XV-14714-00	C - 4	36Y-16334-00	C - 9
5PW-Y2809-01-P0	F - 3	1HX-12116-01	B - 4	4FM-12410-00	B - 9	5PW-13475-00	B - 12	5JJ-14715-00	C - 4	4XV-16335-00	C - 9
5PW-Y2809-01-P3	F - 3	1HX-12117-00	B - 4	5PW-12413-00	B - 9	5PW-13490-00	B - 12	5PW-14777-00	C - 3	4XV-16340-10	C - 9
5PW-Y2809-11-P1	F - 3	1WG-12117-00	B - 4	5PW-12417-01	B - 9	5PW-13597-00	B - 13	5PW-14803-00	C - 2	132-16346-00	C - 14
5PW-Y283G-00-P0	E - 14	1HX-12118-00	B - 4	4XV-12421-00	B - 7	5PW-13598-00	B - 13	5PW-14811-01	C - 3	4XV-16351-00	C - 9
5PW-Y283G-10-P1	E - 14	1WG-12118-00	B - 4	4XV-12422-00	B - 7	5PW-13750-00	B - 14	5PW-14821-00	C - 3	1TX-16352-00	C - 9
5PW-Y283G-20-P2	E - 14	4SV-12119-00	B - 4	5PW-1243A-00	B - 9	5PW-13761-00	B - 14	5PW-14826-00	C - 4	4XV-16356-01	C - 9
5PW-Y283L-00-P0	E - 14	4TV-12119-00	B - 4	5PW-1243E-00	B - 10	5FL-13766-00	B - 14	5PW-14836-00	C - 3	4XV-16370-00	C - 9
5PW-Y283M-00-P0	E - 14	5LV-12121-00	B - 4	5PW-1243F-00	B - 10	4XV-13898-00	B - 12	5PW-14858-00	C - 3	4XV-16382-00	C - 9
5PW-Y283S-00	F - 4	3GM-12126-00	B - 4	11H-12438-10	B - 7	5PW-13906-00	B - 14	5PW-14865-00	C - 3	36Y-16383-00	C - 9
5PW-Y283U-50-P2	F - 2	3FV-12153-09	B - 5	4XV-12439-00	B - 7	5PW-13907-00	D - 13	5PW-14867-00	C - 3	4XV-16384-00	C - 9
5PW-Y283U-60-P1	F - 2	3FV-12153-20	B - 5	5PW-1244G-00	B - 10	5PW-13971-00	B - 15	5PW-14868-00	C - 2	2H7-16385-00	C - 9
5PW-Y283U-70-P2	F - 2	3FV-12153-30	B - 5	4XV-12450-00	B - 7	5PW-13972-00	B - 15	5JJ-14872-00	C - 2	5JJ-17121-01	C - 11
5PW-Y283V-50-P2	F - 2	3LN-12153-09	B - 5	5PW-12461-00	B - 9	5PW-1410F-00	B - 14	5PW-14873-00	C - 2	5JJ-17131-00	C - 11
5PW-Y283V-60-P1	F - 2	3LN-12153-20	B - 5	22W-12462-00	B - 9	5PW-14103-00	B - 14	5JJ-14874-00	C - 2	5JJ-17151-00	C - 11
5PW-Y283V-70-P2	F - 2	1HX-12168-A0	B - 4	5JJ-12469-00	B - 8	5JW-14104-00	B - 15	5PW-14881-00	C - 2	5JJ-17158-00	C - 11
5PW-Y2881-00	E - 14	1HX-12168-F0	B - 4	5PW-12481-00	B - 7	5PW-14112-00	B - 15	5JJ-14882-00	C - 2	5JW-17161-00	C - 11
5PW-11101-01	B - 2	1HX-12168-H1	B - 4	5PW-12482-00	B - 8	5JW-14118-00	B - 14	5JJ-14883-00	C - 2	5JJ-17211-00	C - 12
4KG-1111G-00	B - 2	1HX-12168-K1	B - 4	5PW-12483-00	B - 8	4KM-14137-00	B - 15	5JJ-14886-00	C - 2	5JJ-17221-00	C - 11
5PW-11119-00	B - 2	1HX-12168-M1	B - 4	5PW-12484-00	B - 9	5PW-14137-00	B - 15	5PW-14889-00	C - 3	5JJ-17231-00	C - 12
1WG-11133-11	B - 2	1HX-12168-R1	B - 4	4XV-12485-00	B - 7	3H1-14147-00	B - 15	4KM-14933-00	B - 14	5JJ-17241-00	C - 11
3TJ-11133-10	B - 2	1HX-12168-U1	B - 4	5Y9-12491-00	F - 12	5FL-14147-00	B - 14	5DM-14936-00	B - 14	5JJ-17251-10	C - 12
4XV-11145-00	C - 5	1HX-12168-W1	B - 4			5JW-14147-00	B - 15	5PW-15100-00	C - 5	5PW-17261-00	C - 11
4XV-11165-00	C - 5	1HX-12168-Y1	B - 4	1AA-12535-00	B - 9	4KM-14216-00	B - 15	4XV-15113-00	C - 7	5JJ-17402-00	C - 11
5PW-11181-00	B - 2	1HX-12168-00	B - 4	5PW-12551-00	B - 9	8CC-14216-10	B - 14	5JJ-15163-00	C - 11	5JJ-17411-01	C - 11
5PW-11191-00	B - 2	1HX-12168-20	B - 4	5PW-12552-00	B - 10	5FL-14348-00	B - 14	5PW-15361-00	C - 5	4XV-17460-00	C - 12
5PW-11193-00	B - 2	1HX-12168-40	B - 4	5JJ-12576-00	B - 8	5FL-14348-10	B - 14	3F9-15362-00	C - 6	5PW-18101-00	C - 14
214-11198-01	B - 12	1HX-12168-60	B - 4	5PW-12577-00	B - 9	5PW-14348-00	B - 14	1UF-15379-00	D - 3	5PW-18110-00	C - 14
5PW-1130E-00	C - 4	1HX-12168-80	B - 4	5PW-12579-00	B - 9	5PW-14349-00	B - 14	5PW-15411-00	C - 6	5PW-18112-00	C - 14

NUMERICAL INDEX

PART NO.	GRID NO.	PART NO.	GRID NO.	PART NO.	GRID NO.	PART NO.	GRID NO.	PART NO.	GRID NO.	PART NO.	GRID NO.
5EB-18113-00	C-14	1JK-21735-00	F-3	5PW-23146-00	D-10	5PW-2470F-00	D-14	3FV-25854-00	E-7	5JJ-27420-01	E-10
5PW-18115-00	C-14	5PW-2174X-00	D-5	3XJ-23147-L0	D-10	5PW-24710-01	D-14	2J2-25855-50	E-7	36Y-27424-00	E-11
5LV-18116-00	C-14	2TK-21757-00	F-4		D-11	5JJ-2475X-01	D-14	2VN-25855-00	E-12	4XV-27424-00	D-2
4XV-18127-00	C-14	5PW-2177L-00	E-14	4V4-23153-L0	D-10	5PW-24750-00	D-14	2VN-25866-00	E-7	5JJ-27430-00	E-10
5JJ-18140-00	C-14		F-2	2K8-23158-L0	D-10	5PW-24751-00	D-14	56A-25867-00	E-7	5JJ-27437-00	E-10
4XV-18154-00	C-14		F-3		D-11	5JJ-2478E-00	D-14	5PW-25872-01	E-7	5PW-27440-00	E-10
4XV-18511-00	C-13		F-4	5PW-23170-00	D-10	4BP-24780-00	D-14	5PW-25874-01	E-12	5PW-27442-00	E-9
5JJ-18512-00	C-13	4J2-21778-00	D-2		D-11	5JJ-24792-01	D-14	5PW-25875-00	D-3	5PW-27443-00	E-9
5PW-18513-00	C-13	26H-21828-00	D-5	3LC-23181-00	D-10	4XV-25117-00	D-15	5PW-25876-00	D-3	5JJ-27445-00	E-9
4XV-18531-00	C-13	5PW-21852-00	C-15		D-11	4XV-25118-00	D-15	5EB-25886-01	E-13	5JJ-27446-00	E-10
4XV-18536-00	C-13	5PW-21871-00	D-5	5PW-23340-00	D-11	5PW-25168-00-98	D-15	5PW-25886-00	E-13	5JJ-27813-00	E-12
5PW-18540-00	C-13	5EB-21875-00	D-5	3LC-23357-00	D-10	5PW-25181-00	D-15	5PW-25887-00	E-7	5PW-28100-00	D-4
136-18542-00	C-13	5PW-22110-00	D-6		D-11	4XV-25186-00	D-15	3FV-2589A-00	E-7	5PW-283A0-00	E-14
5PW-21110-00	C-15	5PW-22125-00	D-6	4XV-2341B-00	D-9	5PW-25188-00	D-15	3FV-2589F-00	E-7	5PW-283B1-00	F-2
5PW-2116J-00	D-2	5JJ-22128-00	D-6	4XV-23415-01	D-9	5PW-25317-00	E-3	5PW-2589G-00	E-7	5PW-283B1-10	F-2
5PW-2117F-00	C-15	5JJ-2214F-00	D-7	4XV-23418-00	D-9	5PW-25338-01-98	E-3	3GM-2589H-00	E-7	5PW-283B2-00	F-2
5PW-2117K-00	D-14	4FN-22141-00	D-6	4XV-23434-00	E-6	5PW-25364-00	E-3	3FV-25894-00	E-7	5PW-283B2-10	F-2
5PW-2117M-00	C-15	5PW-22151-00	D-7	5PW-23435-00	D-9	5PW-25366-00	E-3	5JJ-25894-00	E-12	5PW-28307-00	F-2
5PW-2117N-00	C-15	4XV-2217A-00	D-6	3FV-23462-00	D-9	5JJ-25367-00	E-3	5PW-25895-00	E-12	5PW-28315-01	E-14
5PW-21190-00	C-15	5PW-2217M-00	D-6	2H9-23469-00	E-6	5PW-25367-00	E-3	5PW-25914-00	E-5	5PW-28315-11	E-14
5PX-21268-00	D-3	4XV-22184-00	D-6	4XV-23472-00	D-11	4XV-25376-00	E-3	4SV-25919-00	E-2	5PW-28315-21	E-14
		5PW-22210-00	D-8	5PW-23818-00	D-9	5PW-25377-00	E-3	4TT-25919-00	E-5	5PW-2832M-00	F-3
5PW-2134K-00	G-2	5PW-22311-00	D-7	5PW-2411J-00	D-13	4XV-25381-00	E-4	5PW-25921-00	E-5	5PW-2832N-00	F-3
5PW-2137Y-00	C-15	5PW-22873-00	D-7	5PW-24129-00	D-13	4XV-25383-00	E-3	4SV-25924-00	E-2	5PW-2832P-10	E-14
4XV-21376-00	D-3	5PW-22874-00	D-7	5PW-2413B-00	D-12	4XV-25388-00	E-4	3GM-25925-00	E-2	5PW-28328-21	F-2
5JW-2139X-00	C-7	5PW-22875-00	D-7	5PW-2413Y-00	D-12	4XV-25389-00	E-4	4TT-25937-00	E-5	5PW-28328-30	D-5
5EB-2144G-00	E-10	5PW-22876-00	D-7	5PW-24139-00	D-13	5MT-25398-00	D-15	5PW-26121-00	E-6	5PW-28328-40	D-5
5PW-21446-00	D-2	5PW-23102-01	D-10	5PW-2414H-00	D-13		E-3	5PW-26122-00	E-6	4XV-28336-00	E-14
5PW-21486-00	C-15	5PW-23102-11	D-10	3YF-2414J-10	D-2	5MT-25398-10	D-15	4YR-26240-01	E-6	5PW-28338-21	F-2
5PW-21488-00	C-15	5PW-23103-01	D-10	5PW-2414J-00	D-13		E-3	4YR-26241-01	E-6	5PW-28338-30	D-5
4X7-2149Y-00	B-13	5PW-23103-11	D-10	5PW-24141-00	D-13	5MT-25398-20	D-15	5PW-26246-00	E-6	5PW-28338-40	D-5
5EB-21495-00	C-15	5PW-23110-00	D-10	2GH-24181-00	D-12		E-3	5PW-26280-00	E-14	5PW-2834C-00	F-2
5PW-21511-00-P0	D-3	5PW-23111-00	D-10	4FM-24181-00	C-4	4XV-25443-21	E-3	3XW-26281-01	E-6	5PW-2834C-10	F-2
5PW-21511-00-P1	D-3		D-11	4YR-24181-00	D-12	5PW-2580T-00	E-2	3XW-26282-01	E-6	1AE-2834E-00	D-3
5PW-21511-00-P2	D-3	5PW-23118-00	D-10	2GH-24183-00	D-12	5PW-2580U-00	E-2	5PW-26290-00	E-15	5PW-2834E-00	F-3
5PW-2161G-00	D-4		D-11	4XV-24183-00	D-12	5PW-2580W-00	E-5	4SV-26298-00	E-15	5JJ-2834W-00	E-14
5PW-21611-00-P0	D-3	5PW-23120-00	D-11	5JJ-24186-00	D-12	5JJ-2581T-10	E-2	5PW-26302-00	E-6	5PW-2835C-00	F-2
5PW-21611-00-P1	D-3	5PW-23125-00	D-10	5JJ-24187-00	D-12	3LN-2582A-00	E-12	5PW-26332-00	E-7	5PW-2835C-10	F-2
5PW-21611-00-P2	D-3		D-11	5PW-24191-00	D-12	5PW-2582F-00	E-7	5PW-26335-01	E-6	5PW-28356-00	E-14
5PW-21629-00	F-10	5PW-23136-00	D-10	5PW-24192-00	D-13	5EB-2582W-00	E-5	5PW-27211-00	E-12	5PW-2836A-00	F-3
5PW-21631-09	C-15	5PW-23136-10	D-10	5PW-24312-00	D-12	5EB-25828-00	E-5	4XV-27222-01	E-12	5PW-2836C-01	F-2
5PW-21650-00-P0	D-7	5PW-23141-00	D-10	3PA-24356-00	E-7	5GM-25828-00	E-5	5PW-27311-00	E-9	5PW-2836E-00	F-3
5PW-21650-00-P1	D-7		D-11	68V-24376-00	B-14	3TU-2583V-01	E-12	5PW-26302-00	E-6	5PW-2836F-00	F-4
5PW-21669-00	D-3	4XV-23142-00	D-10	5PW-24411-00	B-14	3LN-2585F-00	E-12	5JJ-27321-00	E-9	5PW-2836K-00	F-4
5PW-21711-00-P0	D-5		D-11	5JW-24486-00	D-13	3LN-2585H-00	E-12	4NX-27351-00	E-9	5PW-2836L-00	F-4
5PW-21711-00-P1	D-5	4PU-23144-00	D-10	5PW-24491-00	D-13	3GM-25852-50	E-7	5PW-27352-00	E-9	1AE-2837J-00	D-12
5PW-21711-00-P2	D-5		D-11	3LN-24515-00	B-15	3XP-25852-50	E-12	5JJ-27410-01	E-9	1TX-28371-00	E-14
5PW-21732-00	D-3	5PW-23145-00	D-10	5JJ-24602-00	D-12	2VN-25854-00	E-12	1HX-27415-00	E-14		F-2

NUMERICAL INDEX

PART NO.	GRID NO.	PART NO.	GRID NO.	PART NO.	GRID NO.	PART NO.	GRID NO.	PART NO.	GRID NO.	PART NO.	GRID NO.
1TX-28371-00	F- 3	5PS-82576-01	F- 15	5FL-85790-00	F- 13	90110-06018	C- 5	90159-06150	E- 10	90201-120K4	C- 14
4XV-28371-00	B- 13	5PW-82590-20	F- 14	8CC-85790-01	F- 12		F- 12	90164-05014	E- 14	90201-12541	B- 7
5DM-28371-00	E- 14	4XV-82910-13	F- 11	5PW-85820-00	F- 12		F- 5		F- 8	90201-12790	F- 13
5PW-28371-00	F- 2	4XV-82917-01	F- 11	5PW-85829-00	F- 12	90110-06019	F- 13	90170-06228	C- 14	90201-13008	E- 10
5PW-28372-00	D- 7	5PW-83310-01	F- 7	5PW-85885-00	B- 14	90110-06025	C- 3	90170-28419	D- 9		E- 9
5PW-28386-00	F- 4	1KH-83311-00	F- 7	5PW-85896-00	F- 13	90110-06026	B- 7	90176-06055	E- 15	90201-14014	C- 3
5PW-2848L-00	F- 3	5PW-83318-00	F- 7	5PW-8591A-41	F- 12	90110-06047	B- 11	90176-10075	B- 2	90201-146F9	E- 9
5PW-2848M-00	F- 4	5PW-83320-01	F- 7	9Y582-05113	E- 3	90110-06063	B- 7	90179-05523	E- 14	90201-18013	D- 6
5PW-2848N-00	F- 4	5PW-8333A-00	F- 7	90101-08662	E- 9	90110-06065	C- 8	90179-08327	B- 3	90201-224L4	C- 12
5PW-81410-00	F- 5	5PW-83330-00	F- 7	90101-08766	E- 4	90110-06080	C- 7	90179-08410	C- 4	90201-257R5	E- 4
5PW-81450-00	F- 5	5PW-8334A-00	F- 7	90105-06026	B- 2	90110-06136	C- 7	90179-10006	B- 2	90201-281U8	D- 9
5PW-81670-00	F- 12	5PW-83340-00	F- 7	90105-06154	B- 7	90110-06224	C- 6	90179-10414	B- 2	90201-43008	C- 10
5PW-81673-00	F- 12	4GY-83350-00	F- 15	90105-06718	E- 13	90110-06225	B- 12	90179-10696	C- 15	90202-05123	E- 14
5PW-81801-00	F- 6	3TB-83371-01	F- 15	90105-07342	B- 6	90110-06226	C- 13	90179-20004	C- 9	90202-06001	F- 15
5PW-8181L-00	F- 6	5PW-83500-00	F- 8	90105-08015	C- 5		E- 9	90179-22003	C- 12	90202-30235	D- 9
5PW-81828-00	F- 6	5PW-83500-10	F- 8	90105-10017	D- 6	90110-06258	D- 14	90179-30691	D- 9	90209-25342	C- 11
5PW-8183G-00	F- 6	4XV-83513-00	E- 14	90105-10018	D- 6	90110-10005	C- 15	90183-04039	F- 15	90209-25349	C- 11
5PW-81846-00	F- 6		F- 8	90105-10020	D- 8	90111-06019	C- 14	90183-05074	F- 2	90209-25350	C- 11
5PW-81890-01	F- 6	5PW-8352S-00	F- 8	90105-10021	D- 6	90111-06030	D- 3	90183-06053	E- 12	90209-25342	C- 11
5JW-81940-00	F- 14	5PW-8353E-00	F- 8	90105-10022	E- 11	90111-06043	D- 3		F- 15	90209-30344	C- 11
5JJ-81950-10	F- 13	5PW-83572-00	F- 8	90105-10290	F- 12	90116-10485	E- 3	90185-10009	E- 3	90209-30345	C- 11
5JJ-81950-20	F- 13	4XV-83755-01	F- 12	90105-105A6	F- 5	90116-10619	C- 5	90185-18167	D- 6	90215-23001	C- 9
	F- 15	4XV-83912-11	F- 11	90105-105A7	E- 2	90119-06044	D- 12	90185-24165	E- 4	90215-30233	C- 12
5PW-81950-00	F- 15	5JJ-83913-00	F- 11	90105-14002	D- 15	90119-06052	F- 3	90201-047A2	F- 15	90215-30233	E- 10
5JJ-81952-00	F- 13	5PW-83922-00	E- 7	90109-06013	E- 12	90119-06096	D- 7	90201-050T4	C- 3	90243-08029	E- 9
	F- 15	4XV-83945-00	F- 11	90109-06014	C- 6	90119-06114	D- 9	90201-05033	F- 10	90269-06081	F- 4
5JW-81960-00	F- 15	5LV-83951-00	F- 11		C- 7	90119-06115	C- 3	90201-057H5	F- 15	90269-07076	C- 15
4TX-82100-02	F- 14	5PW-83969-00	F- 11	90109-06015	C- 6	90119-06118	D- 3	90201-05725	F- 10		D- 5
5PW-82115-00	F- 14	5PW-83975-00	F- 11		C- 7	90119-06187	C- 4	90201-06042	E- 10	90269-07077	D- 3
5PW-82116-00	F- 14	4HM-83980-00	E- 7	90109-063F1	D- 3	90119-06190	D- 12		E- 9		D- 5
5PW-8212B-00	D- 3	4KB-84117-00	F- 10	90109-064G6	E- 2	90119-09002	C- 5	90201-06063	D- 2		F- 4
5JJ-82131-00	F- 14	5PW-84310-00	F- 9		E- 5	90149-06013	F- 5	90201-06071	B- 9	90269-08002	C- 15
36Y-82151-00	F- 14	5PW-84310-10	F- 9	90109-065G3	C- 5	90149-06020	B- 2	90201-06431	C- 3		D- 7
5JJ-82151-10	F- 14	5PW-84312-00	F- 9	90109-066F0	B- 2	90149-06233	E- 10	90201-08089	C- 8	90338-08226	F- 12
5JJ-82151-20	F- 14	8V0-84314-10	F- 9	90109-080G5	F- 14		E- 9	90201-081R9	E- 9	90338-15004	C- 15
5JJ-82151-30	F- 14	4SV-84347-00	F- 9	90109-083E0	E- 10	90149-06286	C- 11	90201-08326	D- 2	90338-16262	C- 5
5JW-82151-10	F- 14	5PW-84359-11	F- 9		E- 9	90149-06302	D- 7	90201-08612	C- 4	90338-20263	C- 5
5PW-82309-00	F- 12	5PW-84385-00	F- 9	90109-085G6	E- 11		F- 3	90201-10M76	C- 3	90340-14132	B- 12
5PW-82310-00	F- 12	5PW-84386-00	F- 9		E- 9		F- 4	90201-10013	B- 2	90340-27001	B- 2
5JW-82380-00	B- 14	4SV-84397-00	F- 9	90109-10002	E- 9	90149-06308	D- 14	90201-10020	C- 15	90340-32080	C- 6
	F- 13	2AL-84553-00	F- 14	90109-104G5	C- 15	90149-08296	E- 10	90201-10021	E- 3	90387-06M60	D- 2
5PW-82386-00	B- 14	5PW-84710-00	F- 10	90110-05014	D- 13		E- 9	90201-101J1	E- 9	90387-0600V	D- 7
5JJ-82388-00	F- 15	5PW-84717-00	F- 10	90110-05018	E- 6	90150-05024	E- 14	90201-10118	E- 12	90387-06006	D- 12
5PW-82501-20	F- 14	5PW-84726-00	F- 10	90110-05112	D- 12	90150-05039	D- 5		E- 8	90387-06007	D- 12
5PW-82530-00	F- 14	4HC-84744-00	F- 10	90110-06018	B- 11	90153-06029	B- 8	90201-103U7	F- 5	90387-06023	E- 10
3GB-82540-01	F- 12	5PW-84745-00	F- 10		B- 12	90154-05013	F- 4	90201-10614	C- 10	90387-06024	E- 15
5JJ-82541-00	F- 12	3Y6-85130-02	F- 10		B- 8	90154-05074	D- 13	90201-10669	E- 11	90387-0603J	D- 7
5PX-82566-50	F- 15	5PW-85720-00	F- 12		B- 9	90159-06056	E- 12	90201-107K6	F- 12	90387-062M9	D- 5

NUMERICAL INDEX

PART NO.	GRID NO.	PART NO.	GRID NO.	PART NO.	GRID NO.	PART NO.	GRID NO.	PART NO.	GRID NO.	PART NO.	GRID NO.
90387-06372	D - 7	90450-38040	B - 8	90468-08104	C - 5	91317-06040	B - 7	93306-00420	D - 15	95027-06025	B - 9
90387-065G0	D - 4		B - 9	90468-12069	B - 3	91317-06060	B - 2	93306-20531	E - 3		D - 2
90387-065J6	B - 13	90450-53002	B - 13	90480-12005	D - 7	91380-04006	C - 3	93306-20705	C - 11		F - 6
	D - 3	90450-63001	B - 13	90480-12072	D - 3	91401-16012	E - 12	93306-27208	C - 11	95304-06700	C - 14
	F - 2	90461-10002	F - 15	90480-12314	B - 13	91701-06018	E - 12	93306-37209	C - 12	95304-08700	E - 12
	F - 3	90461-10003	C - 6	90480-12596	F - 2	91808-16023	B - 2	93306-37807	C - 11	95307-08600	E - 4
90387-06697	E - 10	90462-08225	F - 12		F - 3	91808-30031	B - 7	93310-228S5	C - 9	95380-05700	F - 6
90387-07391	B - 9	90462-10013	C - 4	90480-12607	E - 10	92014-08016	C - 6	93310-338S6	C - 8	95604-06200	E - 10
	C - 2	90464-06004	G - 2	90480-14604	D - 2	92017-05030	F - 15	93315-11206	C - 14	95606-06100	E - 7
	D - 2	90464-07004	F - 14	90480-15316	C - 2	92017-06012	D - 5	93315-31502	C - 10	95607-05100	F - 10
90387-08005	D - 3	90464-07259	D - 3	90480-15363	B - 9	92017-06014	C - 8	93315-31758	D - 6	95607-05200	F - 15
90387-08057	D - 2	90464-09M31	D - 5	90501-064L1	C - 13	92017-06020	D - 3	93315-42523	D - 6	95607-06100	F - 11
90387-10001	E - 11	90464-09001	D - 2	90501-12743	E - 10	92902-04100	E - 7	93315-42536	D - 6	95607-06200	D - 12
90387-1012A	D - 6	90464-12036	F - 14	90506-10003	C - 4	92902-04600	E - 7	93317-11020	C - 9	95607-08200	E - 14
90387-1012B	D - 6	90464-12036	F - 14	90506-16005	C - 14	92906-05100	B - 14	93317-43580	E - 3	95607-10200	D - 6
90387-1013U	D - 6	90464-13073	F - 15	90506-18003	E - 9	92906-05600	B - 14	93399-99932	D - 9		D - 8
90387-12012	C - 15		C - 2	90506-20377	E - 12	92907-06100	B - 9	93410-06053	C - 3		E - 9
90387-1211D	C - 14	90464-13077	F - 15	90508-164B2	C - 9	92907-06200	E - 12	93410-08072	C - 8	95617-08625	B - 2
90387-2511A	C - 11		F - 14	90508-18134	E - 9	92907-06600	B - 9	93420-61M07	E - 3	95707-06500	D - 14
90387-2810U	C - 11	90464-13133	F - 14	90508-18135	E - 10	92907-08600	C - 9	93440-07149	B - 2		D - 2
90387-2811B	C - 11	90464-15157	B - 15	90508-32682	C - 14	92990-04600	C - 3	93440-10153	B - 2		D - 3
90387-3310V	C - 11	90464-16005	F - 14	91314-06010	C - 4	93101-12004	C - 14	93440-28062	C - 11		F - 15
90387-3311C	C - 11	90464-16006	B - 15	91314-06016	D - 12	93102-12372	B - 7	93440-32063	C - 11	95807-06012	F - 15
90401-10172	E - 12	90464-16007	F - 14	91314-06020	C - 6	93102-15212	C - 9	93440-72049	C - 12		F - 4
	E - 8	90464-16039	F - 15	91314-06025	C - 6	93102-45465	C - 12	93501-04011	E - 10		G - 2
90401-20145	B - 12		F - 15		E - 6	93106-28043	D - 15	93603-12007	B - 7	95807-06014	D - 2
90413-07023	B - 10	90464-17001	F - 14	91314-06035	C - 6	93106-40013	E - 3	93603-17070	B - 7	95814-06050	C - 5
90430-06014	B - 2	90464-37257	D - 3		E - 10	93109-17071	D - 6	93604-10011	B - 7	95817-06012	F - 14
	B - 7	90465-04020	F - 12	91314-06040	C - 6	93210-06667	B - 11	93604-29151	F - 12	95817-06020	B - 13
	C - 8	90465-08013	F - 12	91314-06050	C - 6		B - 7	93606-07M17	C - 3	95817-06025	C - 9
90430-08143	C - 6	90465-08028	F - 12	91314-08030	D - 11	93210-09165	B - 11	93607-44190	B - 6	95817-06045	C - 5
90430-09002	B - 15	90465-08191	F - 5		D - 9	93210-12790	C - 5	93608-21002	C - 6	95817-06055	C - 5
90430-10148	F - 12	90465-14011	B - 10	91314-08040	D - 10	93210-14003	B - 12	93900-00030	D - 15	95817-06060	C - 5
90430-12202	F - 13	90467-08003	D - 5		D - 11	93210-15566	B - 12		E - 3	95817-06065	C - 5
90445-081H0	D - 5		D - 12	91314-10040	C - 15	93210-15620	E - 7	94112-17054	D - 15	95817-06070	C - 5
90445-081H0	B - 10	90467-09006	B - 13	91314-10050	C - 15	93210-16314	C - 5	94119-17019	E - 3	95817-06110	D - 12
90445-094K7	D - 12	90467-10041	D - 5	91317-04025	F - 15	93210-18417	B - 8	94580-25078	B - 11	95817-08025	C - 15
90445-102G7	B - 13	90467-11019	B - 10	91317-05010	D - 12	93210-235A1	B - 8	94591-49130	B - 6	95817-08030	C - 4
90445-11M52	B - 13	90467-11090	B - 9	91317-06012	B - 12	93210-23787	B - 9	94682-05031	E - 3	95817-08040	C - 4
90445-11013	C - 5		B - 15		B - 8	93210-25711	F - 6	94701-00407	B - 2	95817-08050	C - 5
90445-161K7	E - 9	90467-120A1	B - 15		C - 2	93210-27194	C - 6	94701-00408	B - 2	95824-06020	C - 14
90445-19002	E - 12	90467-12003	B - 15		E - 7	93210-27370	B - 8	95024-06012	B - 2	95827-06020	C - 2
90446-17346	B - 10	90467-12191	C - 5	91317-06014	F - 12	93210-32172	C - 6	95024-08035	C - 15	95827-06025	B - 9
90450-19001	B - 10	90467-14015	E - 12	91317-06016	B - 8	93210-357A2	B - 7	95027-06008	F - 14	95827-06030	F - 15
90450-22017	B - 9	90467-14057	C - 2	91317-06025	B - 12	93210-47675	B - 8	95027-06020	B - 8	97307-06012	B - 9
90450-28014	B - 9	90467-15001	C - 2		B - 7	93210-55669	F - 6		E - 7	97706-04012	F - 10
90450-32015	B - 9	90467-15054	C - 2		E - 6	93306-00106	B - 7		F - 11		F - 7
90450-35001	B - 8	90467-16181	C - 2	91317-06035	B - 7	93306-00304	C - 9	95027-06025	B - 6	97707-40012	D - 14
	B - 9	90467-17089	C - 2		B - 7						

NUMERICAL INDEX

PART NO.	GRID NO.	PART NO.	GRID NO.	PART NO.	GRID NO.	PART NO.	GRID NO.	PART NO.	GRID NO.
97707-50016	F - 10								
	F - 4								
	F - 9								
97707-50020	F - 13								
97707-50514	F - 12								
97707-60020	F - 12								
98502-04010	B - 14								
98502-04012	E - 7								
98506-05016	B - 14								
98507-04010	F - 11								
98507-05022	F - 11								
98507-05025	B - 13								
	F - 11								
98507-05045	B - 13								
98707-03016	F - 11								
98907-05008	D - 13								
99001-07600	C - 9								
99009-10400	C - 10								
99241-00080	D - 5								
99246-00080	D - 5								
99246-00320	F - 3								
	F - 4								
99247-00080	D - 5								
99247-00320	F - 3								
99530-08012	B - 12								
	C - 6								
	C - 7								
99530-10014	C - 5								
99530-10114	C - 5								

CONTENTS

ENGINE

CYLINDER	B2
CRANKSHAFT. PISTON	B3
VALVE	B4
CAMSHAFT. CHAIN	B6
WATER PUMP	B7
RADIATOR. HOSE	B9
OIL PUMP	B11
OIL CLEANER	B12
INTAKE	B13
INTAKE 2	B14
AIR INDUCTION SYSTEM	C2
EXHAUST	C3
CRANKCASE	C5
CRANKCASE COVER 1	C6
STARTER	C8
CLUTCH	C9
TRANSMISSION	C11
SHIFT CAM. FORK	C13
SHIFT SHAFT	C14

CHASSIS

FRAME	C15
FENDER	D3
SIDE COVER	D5
REAR ARM	D6
REAR SUSPENSION	D8
STEERING	D9
FRONT FORK	D10
FUEL TANK	D12
SEAT	D14
FRONT WHEEL	D15
FRONT BRAKE CALIPER	E2

REAR WHEEL	E3
REAR BRAKE CALIPER	E5
STEERING HANDLE. CABLE	E6
FRONT MASTER CYLINDER	E7
STAND. FOOTREST	E9
REAR MASTER CYLINDER	E12
COWLING 1	E14
COWLING 2	F2
GENERATOR	F5
STARTING MOTOR	F6
FLASHER LIGHT	F7
METER	F8
HEADLIGHT	F9
TAILLIGHT	F10
HANDLE SWITCH. LEVER	F11
ELECTRICAL 1	F12
ELECTRICAL 2	F14

INDEX

NUMERICAL INDEX	M1
-----------------------	----