

YAMAHA



CATALOGO DE REPUESTOS

XV1100'98 (3LPH)

ESPAÑA

YAMAHA
GENUINE
Parts & Accessories

183LP-352S1

A2

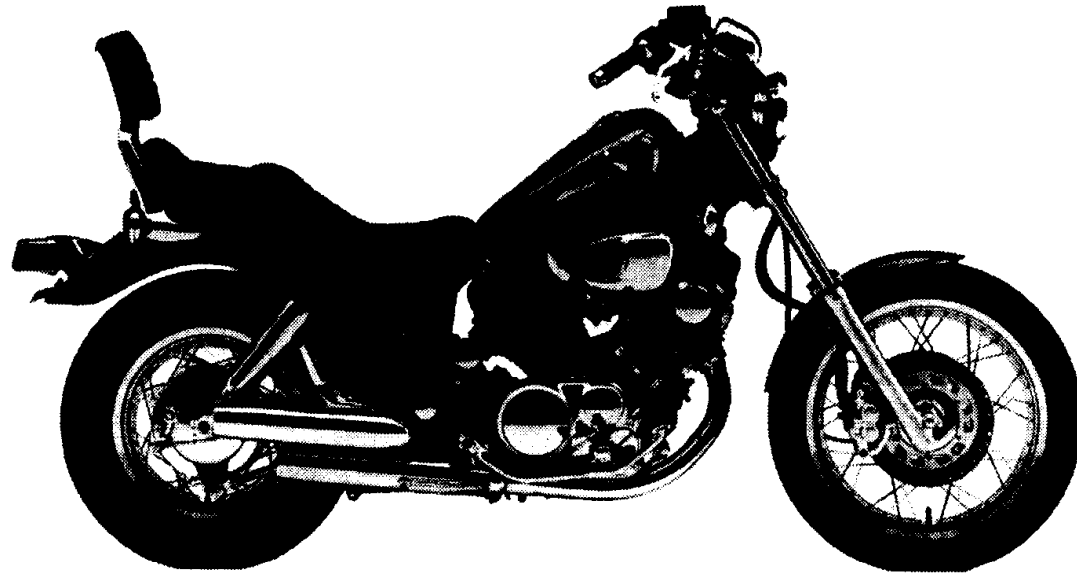

A3

PROLOGO

Este Catálogo de Repuestos corresponde a las piezas para el(los) modelo(s) del recuadro siguiente. Al formular el pedido de repuestos, se ruega citar este Catálogo de Repuestos y especificar correctamente los números de parte y los nombres de parte.

XV1100'98 (3LPH)

- Las modificaciones y agregados que se hayan realizado después de la edición de este Catálogo de Repuestos, serán anunciados en las Informaciones de Recambios Yamaha.
- Abreviaciones
En este Catálogo de Repuestos se emplean las siguientes abreviaciones.
"UR" Usar el número de partes especificado
"UN" Usar la cantidad necesaria
"AP" Piezas sustitutivas
"UM" Fabricación local (Partes necesarias que se pedirán localmente)
"F#" No. de bastidor aplicable
- Las piezas suministradas como conjunto se describen con un punto (.) que precede al nombre de la pieza como se indica a continuación.

EJEMPLO

CONJUNTO CARBURADOR
.INYECTOR, piloto
.BOQUILLA, principal

- Cantidad de componentes de un conjunto
La numeración que aparece a la derecha de cada descripción, indica la cantidad de piezas por cada unidad de conjunto.

EJEMPLO

PIEZAS NO.	DESCRIPCION	CANT.	OBSERVACION
2F5-83310-60	ENSAMBLAJE DE LA LUZ	2	
115-83311-60	.BOMBILLA (6V-1 8W)	1	
1M1-83309-60	.REFLECTOR	1	

- Los colores de los componentes se indican como sigue en la columna de "OBSERVACIONES".

EJEMPLO

PIEZAS NO.	DESCRIPCION	CANT.	OBSERVACION
2N4-24110-00-X5	.COMP. DEL TANQUE	2	MXR
3J1-24240-10	.GRAFICO, DEL TANQUE	1	para MXR

- Números de Serie

① No. de Serie del motor.

② No. de Serie del bastidor

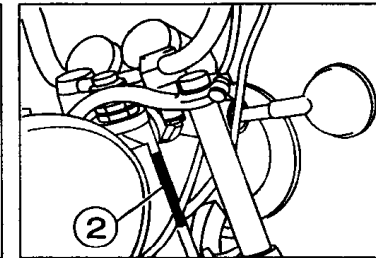
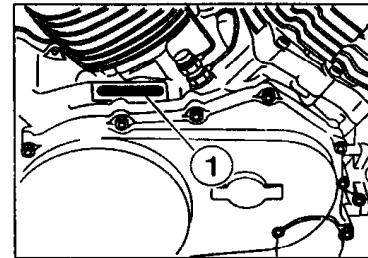

- Debe tenerse en cuenta que las ilustraciones sirven como guía para la búsqueda de las referencias y no deben usarse para el montaje. Durante el montaje, se recomienda usar el manual de Taller correspondiente.
- EL asterisco (*) antes del número de referencia indica los elementos modificados después de la primera edición.

CONTENIDO

MOTOR

CULATA DE CILINDRO-----	B2
CILINDRO-----	B4
CIGUENAL. PISTON-----	B5
VALVULA-----	B6
ARBOL DE LEV. CADENA-----	B7
BOMBA DE ACEITE-----	B9
FILTRO ACEITE-----	B10
ADMISION-----	B11
CARBURADOR-----	B14
DESCARGA-----	C2
CARTER-----	C3
CUBIERTA DE CARTER 1-----	C4
EMBRAG. DEL ARRANQUE-----	C6
EMBRAGUE-----	C7
TRANSMISION-----	C9
ENGR. MEDIO DE TRAC.-----	C10
LEVA DE CAMBIO. HORQ-----	C12
EJE DE CAMBIO. PEDAL-----	C13

SHASIS

CUADRO-----	C14
GUARDABARRO-----	D2
CUBIERTA LATERAL-----	D4
BRAZO TRASERO. SUSPENSION-----	D5
EJE DE TRACCION-----	D6
DIRECCION-----	D8
HORQUILLA DELANTERA-----	D9
DEPOSITO DE COMBUSTIBLE-----	D11
ASIENTO-----	D13
RUEDA DELANTERA-----	D14
CALIBRE FRENO DELANTERA-----	D15
RUEDA TRASERA-----	E2

MANUBRIO. CABLE-----	E4
CILINDRO MAESTRO DELANTERO-----	E5
SOPORTE. APOYAPIE-----	E6
GENERADOR-----	E9
MOTOR DE ARRANQUE-----	E10
LUZ DE DESTELLADOR-----	E11
MEDIDOR-----	E12
FARO DELANTERO-----	E13
LUZ DE COLA-----	E14
INTERRUPTOR DE MANIJA. PALANCA-----	E15
EQUIPO ELECTRICO 1-----	F2
EQUIPO ELECTRICO 2-----	F4

INDICE

NUMERICAL INDEX-----	M1
----------------------	----

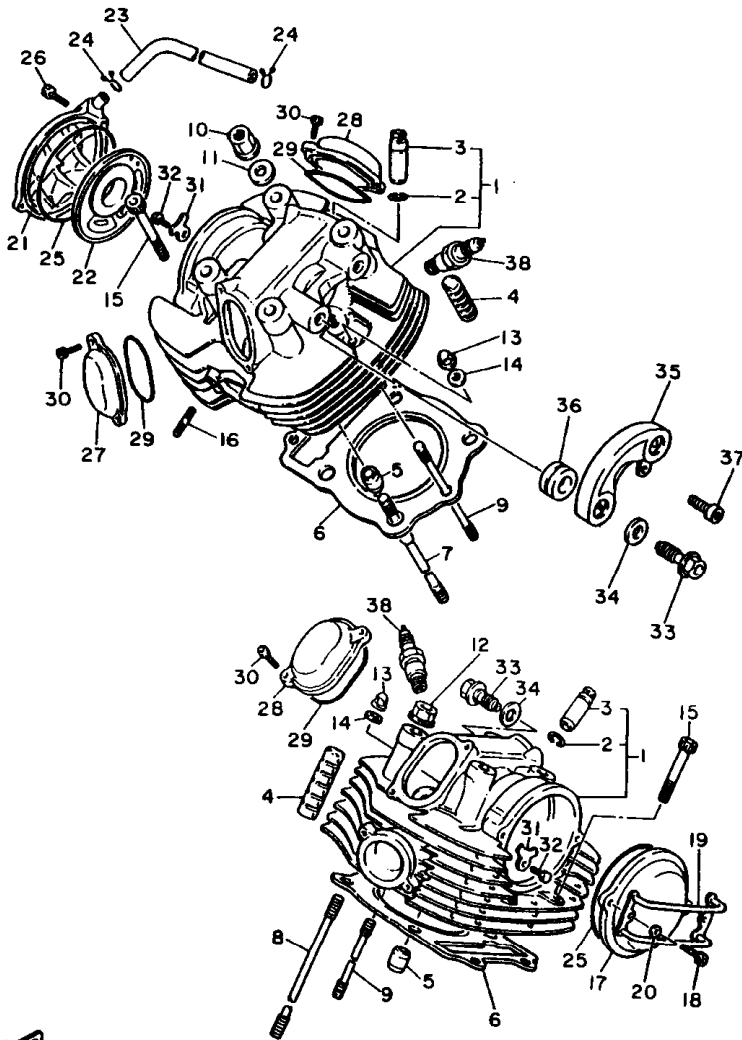

FIG. 1 CULATA DE CILINDRO

REF. NO.	CODIGO NO.	DESCRIPCION	Q.T.			OBSERVACION
1	1TF-11102-02	CULATA DE CILINDRO COMPLETA	2			
2	93440-14086	.BOLA	2			
3	4X7-11133-10	.GUIA VALV.DE ADM.	2			
4	4X7-11127-00	AMORTIGUADOR 3	8			
5	91817-30011	PASADOR DE CLAVIJA	4			
6	42H-11181-00	JUNTA, DE CULATA 1	2			
7	4X7-11363-01	PERNO RETEN DE CILINDRO 3	4			
8	90116-12469	ESPARRAGO	4			
9	90116-10344	ESPARRAGO	2			
10	90179-12326	TUERCA	4			
11	90201-125A3	ARANDELA PLANA	4			
12	90179-12325	TUERCA	4			
13	90176-10075	TUERCA CORONA	2			
14	90201-101A4	ARANDELA PLANA	2			
15	91314-08050	PERNO	4			
16	90116-08104	ESPARRAGO	4			
17	42X-11185-01	CUBIERTA CULATA CIL.LAT.1	1			
18	91314-06016	PERNO	2			
19	42X-11152-00	SOPORTE DE CULATA DE CINDRO CU	1			
20	90202-05208	ARANDELA DE PLANA	2			
21	42X-1111H-01	CUBIERTA LATERALE DE CULATA 4	1			
22	42X-11165-00	PLACA RESPIRADERO	1			
23	42X-11166-01	TUBO RESPIRADERO 1	1			
24	90467-14015	PRESILLA	2			
25	93210-92448	ANILLO O	2			
26	91314-06025	PERNO	2			
27	42H-11186-01	CUBIERTA CULATA CIL.LAT.2	2			



3DR1332-8010

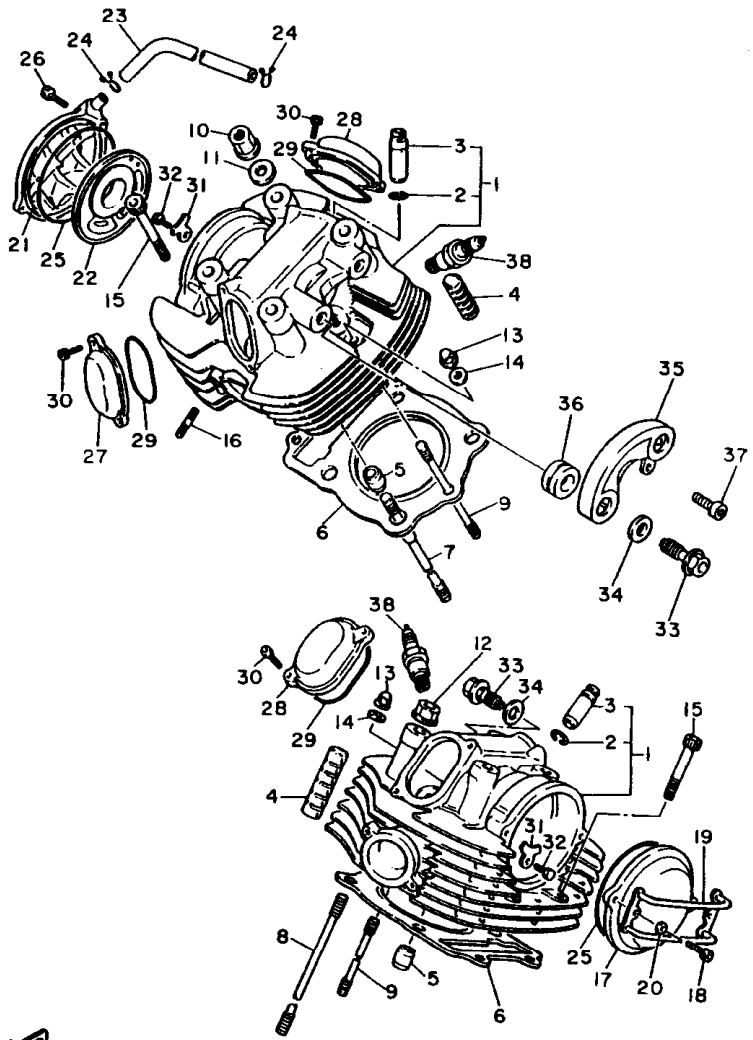
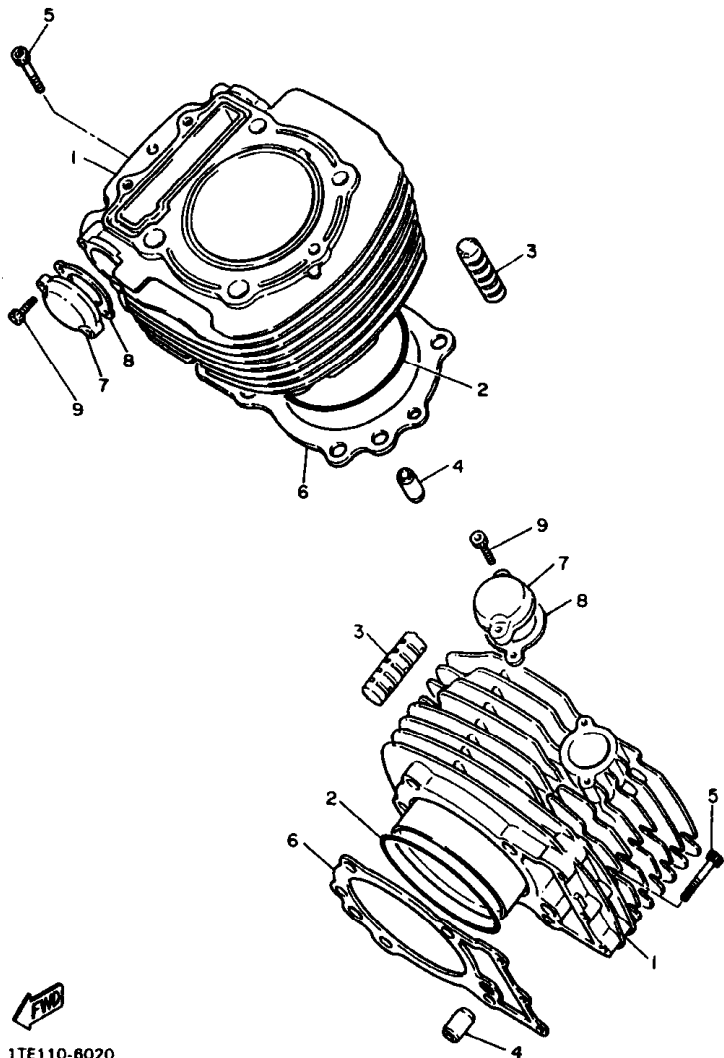

FIG. 1 CULATA DE CILINDRO

REF. NO.	CODIGO NO.	DESCRIPCION	ALPH			OBSERVACION
28	4X7-11187-01	CUBIERTA CULATA CIL.LAT.3	2			
29	93210-62446	ANILLO O	4			
30	91314-06016	PERNO	8			
31	4X7-1111F-00	PLACA	2			
32	97017-08020	PERNO	2			
33	90401-16065	PERNO DE UNION	2			
34	90430-17168	JUNTA	2			
35	1RM-1112E-00	TAPA CULATA DE CILINDRO 3	1			
36	90480-23444	TAPON	2			
37	91317-06010	PERNO	1			
38	94701-00218	BUJIA (NGK BPR7ES)	2			UR
	94701-00220	BUJIA (ND W22EPR-U)	2			UR



3DR1332-8010



1TE110-8020

FIG. 2 CILINDRO

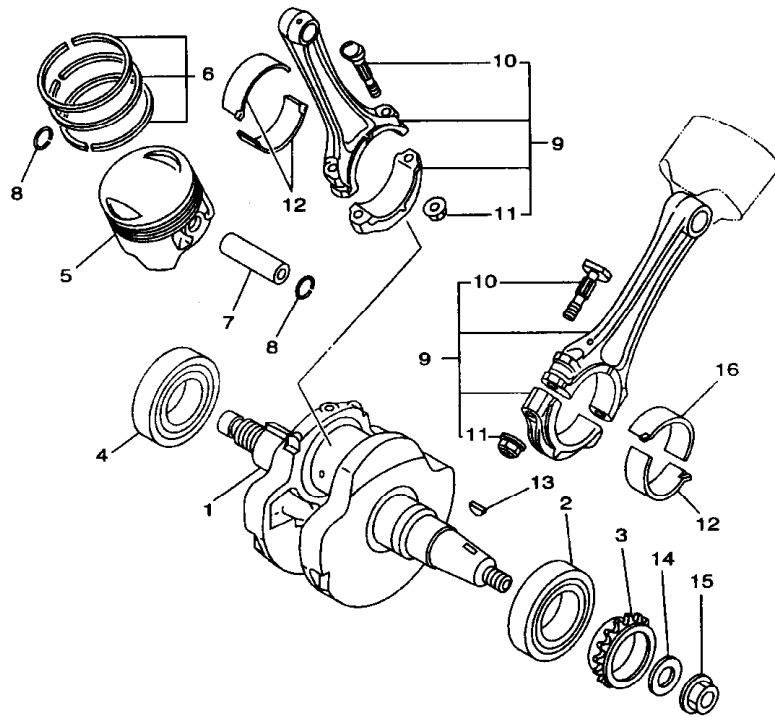
REF. NO.	CODIGO NO.	DESCRIPCION	SLPH				OBSERVACION
1	1TA-11310-00	CILINDRO	2				
2	93211-01467	ANILLO O	2				
3	4X7-11161-00	AMORTIGUADOR 1	4				
4	90387-087A5	CASQUILLO CON VALONA	4				
5	91314-06040	PERNO	6				
6	3EG-11351-01	JUNTA, DE CILINDRO	2				
7	4X7-12215-01	TAPA CAJA DE TENSOR	2				
8	4DW-12213-00	EMPAQUE DE CAJA TENSOR	2				
9	91314-06025	PERNO	4				



FWD
4XN3100-8030

FIG. 3 CIGUENAL. PISTON

REF. NO.	CODIGO NO.	DESCRIPCION	3LPH			OBSERVACION
1	1TA-11411-00	CIGUENAL	1			
2	93306-30808	COJINETE	1			
3	4X7-13354-00	CATALINA	1			
4	93306-30808	COJINETE	1			
5	1TA-11631-00-A0	PISTON(STD)	2			
	1TA-11636-00	PISTON (0.50MM O/S)	2			AP
	1TA-11638-00	PISTON (1.00MM O/S)	2			AP
6	1TA-11610-00	JUEGO DE AROS (NORMA)	2			
	1TA-11610-20	JUEGO DE AROS (0.50MM O/S)	2			AP
	1TA-11610-40	JUEGO DE AROS (1.00MM O/S)	2			AP
7	5A8-11633-00	PASADOR, PISTON	2			
8	93450-24028	BOLA	4			
9	5A8-11650-00	BIELA COMPLETA	2			
10	4X7-11654-01	.TORNILLO DE BIELA	2			
11	90179-09379	.TUERCA	2			
12	4X7-11656-00	COJINETE PLANO	3			UR AZUL
	4X7-11656-10	COJINETE PLANO	3			UR NEGRO
	4X7-11656-20	COJINETE PLANO	3			UR CASTANO
	4X7-11656-30	COJINETE PLANO	3			UR VERDE
	4X7-11656-40	COJINETE PLANO	3			UR AMARILLO
13	90280-05048	CUNA WOODRUFF	1			
14	90201-165H4	ARANDELA PLANA	1			
15	90179-16448	TUERCA	1			
16	5G5-11656-00	COJINETE PLANO	1			UR NEGRO
	5G5-11656-10	COJINETE PLANO	1			UR CASTANO
	5G5-11656-20	COJINETE PLANO	1			UR VERDE

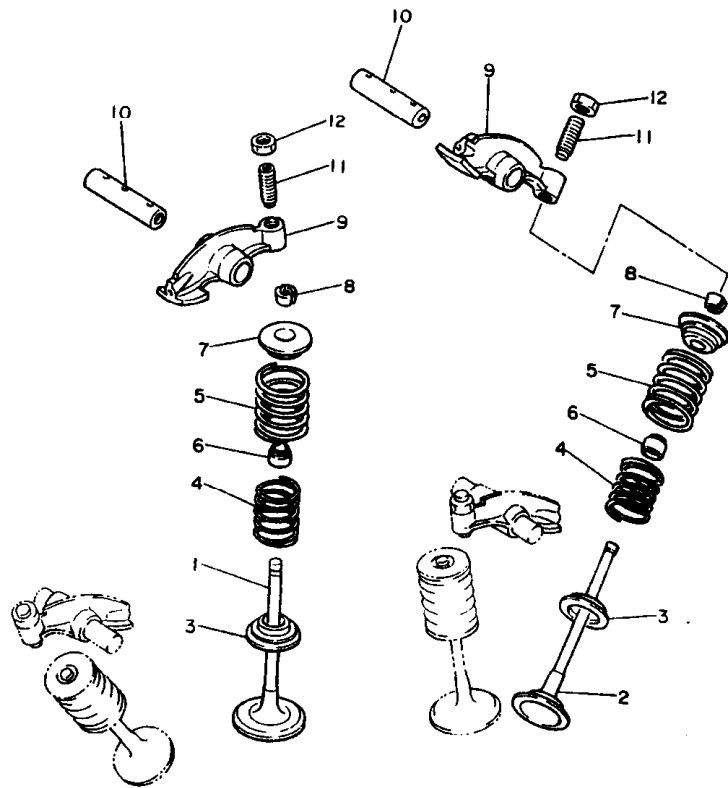
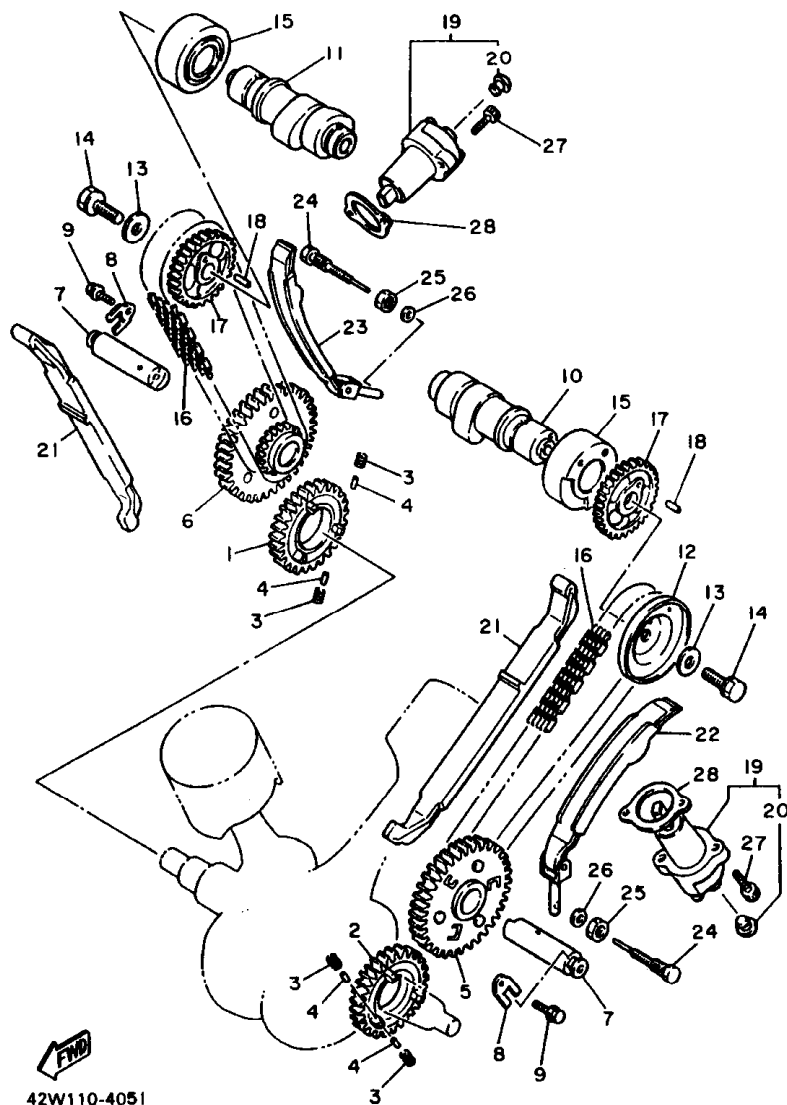

FIG. 4 VALVULA

REF. NO.	CODIGO NO.	DESCRIPCION	3LPH			OBSERVACION
1	2J2-12111-01	VALVULA DE ADMISION	2			
2	5A8-12121-00	VALVULA DE ESCAPE	2			
3	4X7-12116-00	ASIENTO RESORTE DE VALVULA	4			
4	1TA-12113-00	RESORTE VALVULA INTERNA	4			
5	1TA-12114-00	RESORTE VALVULA EXTERIOR	4			
6	341-12119-02	SELLO DE ACEITE VALVULA	4			
7	4X7-12117-00	RETEN RESORTE DE VALVULA	4			
8	4X7-12118-00	SEGURO DE VALVULA	8			
9	42X-12151-00	BRAZO DE BALANCIN DE VALVULA	4			
10	4X7-12156-01	EJE DE BALANCIN	4			
11	4X7-12159-00	TORNILLO DE AJUSTE DE VALVULA	4			
12	90170-08173	TUERCA	4			



5E3171-1050



42W110-4051

FIG. 5 ARBOL DE LEV. CADENA

REF. NO.	CODIGO NO.	DESCRIPCION	3LPH			OBSERVACION
1	4X7-11536-00	ENGRANAJE TRACCION (35T)	1			
2	4X7-11534-00	ENGRANAJE TRACCION DE INTERRUPT	1			
3	90501-21133	RESORTE DE COMPRESION	12			
4	93605-10090	PASADOR DE CLAVIJA	12			
5	4X7-11540-02	CATALINA DE CADENA COMPLETO	1			
6	4X7-11550-01	CATALINA COMP DE CADENA	1			
7	4X7-12247-01	EJE TENSOR	2			
8	90209-06205	ARANDELA DE SEPARACION	2			
9	90105-06154	TORNILLO CON ARANDELA	2			
10	42H-12171-00	ARBOL DE LEVAS 1	1			
11	42H-12181-00	ARBOL DE LEVAS 2	1			
12	42X-11145-00	PLACA RESPIRADERO 2	1			
13	90201-10591	ARANDELA PLANA	2			
14	90101-10303	TORNILLO	2			
15	90380-25125	CASQUILLO SOLIDO	2			
16	94590-45098	CADENA	2			
17	4X7-12176-00	CATALINA DE CADENA (28T)	2			
18	93604-10011	PASADOR DE CLAVIJA	2			
19	4X7-12210-01	TENSOR CADENA DE LEVA	2			
20	90338-06121	TAPON	1			
21	4X7-12231-00	TOPE DE GUIA 1	2			
22	4X7-12241-00	TOPE DE GUIA 2	1			
23	4X7-12221-00	TOPE DE GUIA 3	1			
24	90109-08592	PERNO	2			
25	95307-08700	TUERCA	2			
26	92907-06600	ARANDELA	2			
27	91314-06025	PERNO	4			

FIG. 5 ARBOL DE LEV. CADENA

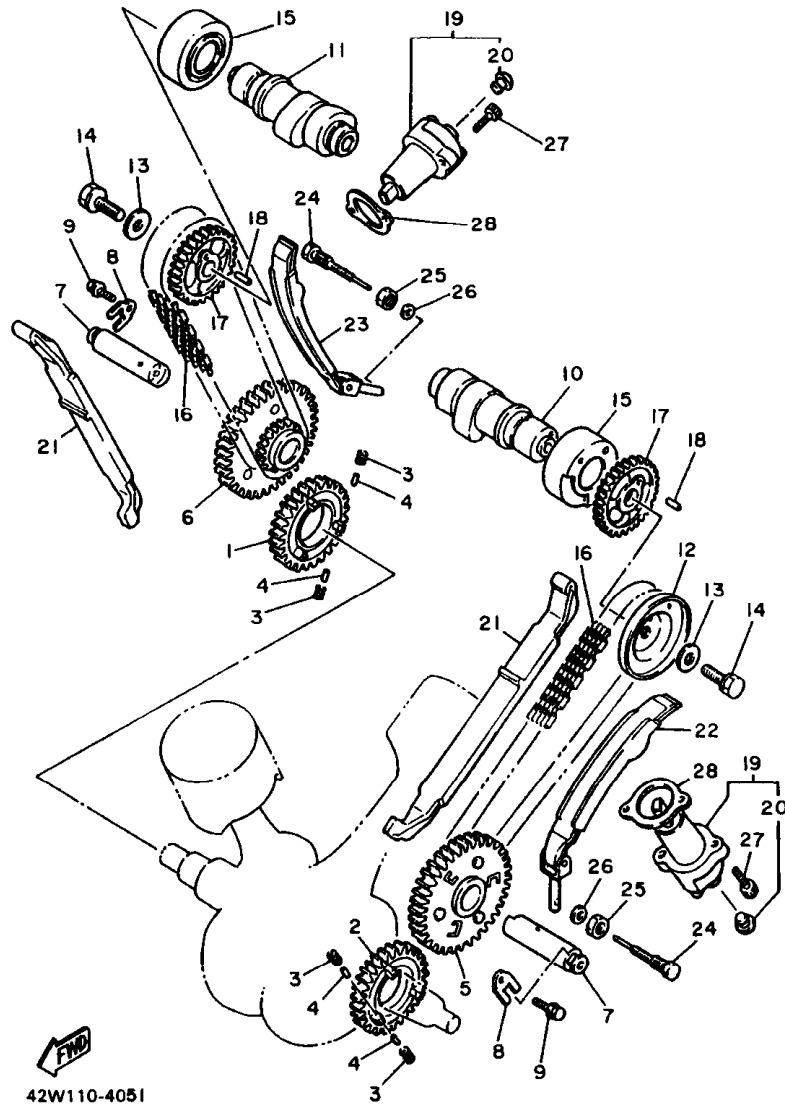

42W110-4051

REF. NO.	CODIGO NO.	DESCRIPCION	3LPH				OBSERVACION
28	4DW-12213-00	EMPAQUE DE CAJA TENSOR	2				

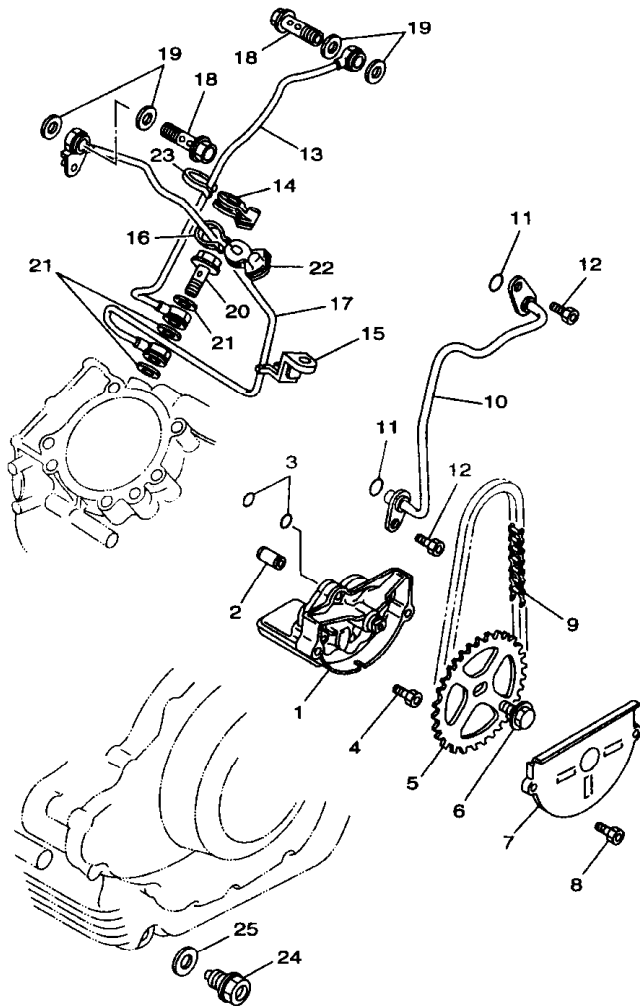

3JLV100-8060

FIG. 6 BOMBA DE ACEITE

REF. NO.	CODIGO NO.	DESCRIPCION	SLPH				OBSERVACION
1	10L-13300-00	BOMBA DE ACEITE COMPLETA	1				
2	99510-08016	PASADOR, DE ESPIGA	1				
3	93210-07135	ANILLO O	2				
4	91317-06040	PERNO	3				
5	4X7-13355-00	CATALINA IMPULSADA (35T)	1				
6	90105-06154	TORNILLO CON ARANDELA	1				
7	10L-13327-00	CUBIERTA ENGRANAJE DE BOMBA	1				
8	91317-06010	PERNO	2				
9	94580-25066	CADENA	1				
10	4X7-13171-00	TUBO CONDUCTOR 2	1				
11	93210-07135	ANILLO O	2				
12	91317-06010	PERNO	2				
13	4X7-13405-00	TUBO DE ACEITE COMPL. 1	1				
14	4X7-15485-01	GRAMPA	1				
15	4X7-15484-00	GRAMPA 2	1				
16	90468-05113	PRÉSILLA	1				
17	1RM-13406-00	TUBO DE ACEITE COMPL. 2	1				
18	90401-16067	PERNO DE UNION	2				
19	90430-17168	JUNTA	4				
20	90401-10102	PERNO DE UNION	1				
21	90430-15169	JUNTA	3				
22	4X7-15485-01	GRAMPA	1				
23	90468-05113	PRESILLA	1				
24	90340-14135	TORNILLO, DE DRENAJE	1				
25	214-11198-01	EMPAQUE	1				

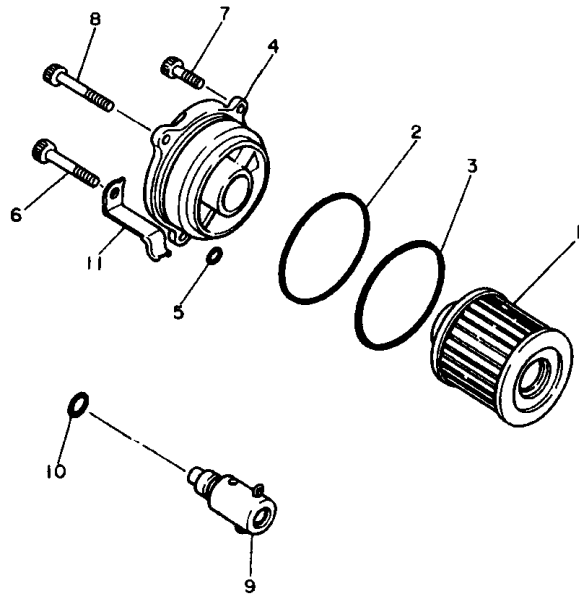

5E3171-1070

FIG. 7 FILTRO ACEITE

REF. NO.	CODIGO NO.	DESCRIPCION	SLPH				OBSERVACION
1	4X7-13440-01	ELEMENTO FILTRO DE ACEITE	1				
2	93210-56459	ANILLO O	1				
3	93210-54452	ANILLO O	1				
4	1RM-13447-00	TAPA DEL ELEMENTO	1				
5	93210-07135	ANILLO O	1				
6	90109-06667	PERNO	1				
7	91314-06020	PERNO	1				
8	91314-06050	PERNO	1				
9	4G0-13490-01	VALVELA DE DESCOMPRESION	1				
10	93210-10096	ANILLO O	1				
11	90462-10098	BRIDA	1				

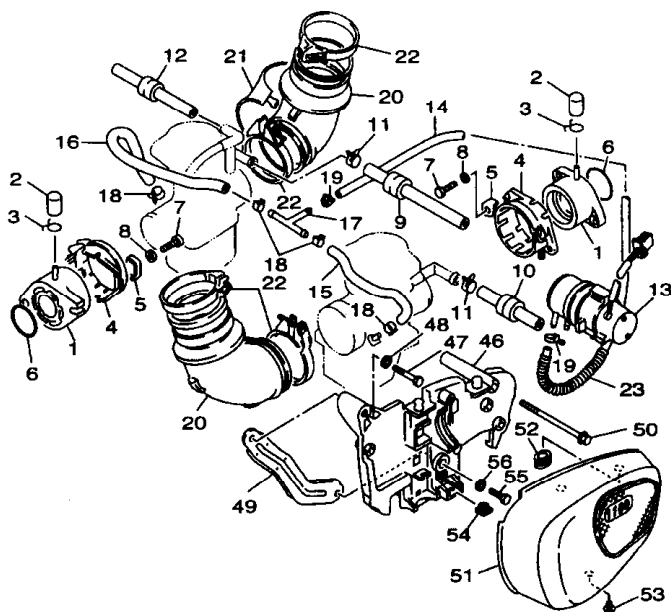
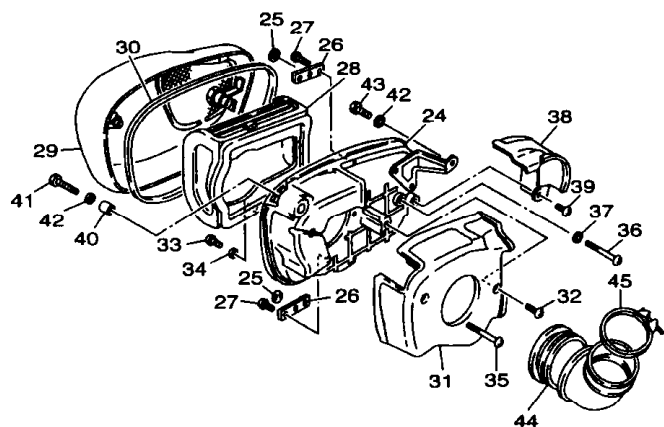

FWD
3LPE332-7080

FIG. 8 ADMISION

REF. NO.	CODIGO NO.	DESCRIPCION	SLPH				OBSERVACION
1	24M-13586-01	TOBERA DE CARBURADOR 1	2				
2	16G-13569-00	TAPON CIEGO	2				
3	90467-10039	PRESILLA	2				
4	42X-13564-01	CUBIERTA DE MULTIPLE	2				
5	42X-13578-00	ARANDELA	2				
6	93210-44545	ANILLO O	2				
7	97027-06020	PERNO	4				
8	92907-06600	ARANDELA	4				
9	3CG-14197-00	TUBO RESPIRADERO	1				
10	3CG-14987-00	TUBO	1				
11	90467-14057	PRESILLA	2				
12	3CG-14396-00	TUBO	1				
13	42H-13907-00	BOMBA DE COMBUSTIBLE COMPLETA	1				
14	42H-13971-00	ANILLO DE ESPACIADOR	1				
15	1TA-14349-00	TUBO	1				
16	1TA-14348-00	MANGUERA	1				
17	90413-07023	UNION	1				
18	90467-10135	PRESILLA	4				
19	90460-12256	BRIDA, DE UNION	2				
20	10L-14453-01	UNION DEL FILTRO DEL AIRE 1	2				
21	10L-14407-00	CUBIERTA	1				
22	90460-65169	BRIDA, DE UNION	4				
23	90501-100F8	RESORTE DE COMPRESION	1				
24	42X-14401-01	CAJA DE FILTRO DE AIRE COMPL.	1				
25	92907-04600	ARANDELA	2				
26	42X-14477-00	PLACA	2				
27	97707-40112	TORNILLO ROSCA HEMBRA	4				

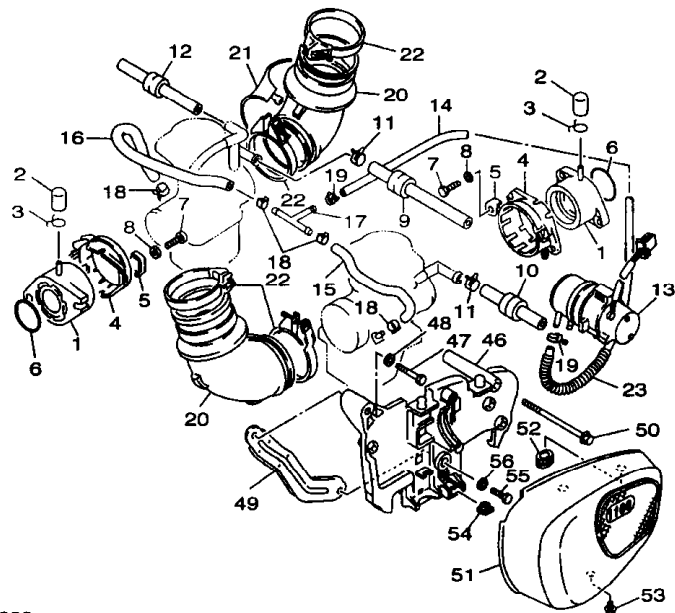
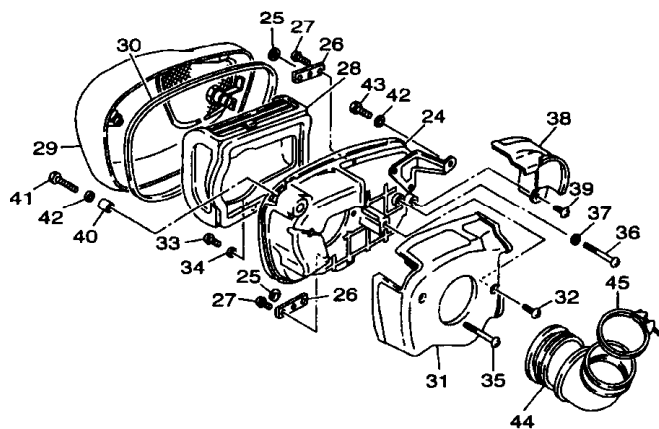

3LPE332-7080

FIG. 8 ADMISION

REF. NO.	CODIGO NO.	DESCRIPCION	3LPH				OBSERVACION
28	42X-14451-00	ELEMENTO DEL FILTRO DEL AIRE	1				
29	1TA-14422-00	TAPA CAJA DE FILTRO 2	1				
30	42X-14452-00	SELLO	1				
31	1TA-1441A-00	CUBIERTA DE CAJA FILTRO 1	1				
32	97707-50508	TORNILLO ROSCA HEMBRA	1				
33	98507-05012	TORNILLO DE CABEZA CON PLANA	1				
34	92907-05600	ARANDELA	1				
35	98507-06080	TORNILLO DE CABEZA CON PLANA	1				
36	98507-06050	TORNILLO DE CABEZA CON PLANA	1				
37	92907-06600	ARANDELA	1				
38	1TA-1441E-00	CUBIERTA DE CAJA DE FILTRO 2	1				
39	97707-50508	TORNILLO ROSCA HEMBRA	1				
40	90387-07598	CASQUILLO CON VALONA	1				
41	91317-06030	PERNO	1				
42	92907-06200	ARANDELA	2				
43	91317-06012	PERNO	1				
44	42X-14485-00	TUBO DE UNION	1				
45	90460-65169	BRIDA, DE UNION	1				
46	42X-14663-02	PLACA	1				
47	91317-06090	PERNO	1				
48	92907-06200	ARANDELA	1				
49	42X-14484-00	PLACA	1				
50	95807-06025	TUERCA DE REBORDE	1				
51	1TA-14603-00	ZAPATA DE CORREDERA	1				
52	90480-14074	TAPON	2				
53	95807-06014	TUERCA DE REBORDE	1				
54	12R-14484-01	PLACA	1				

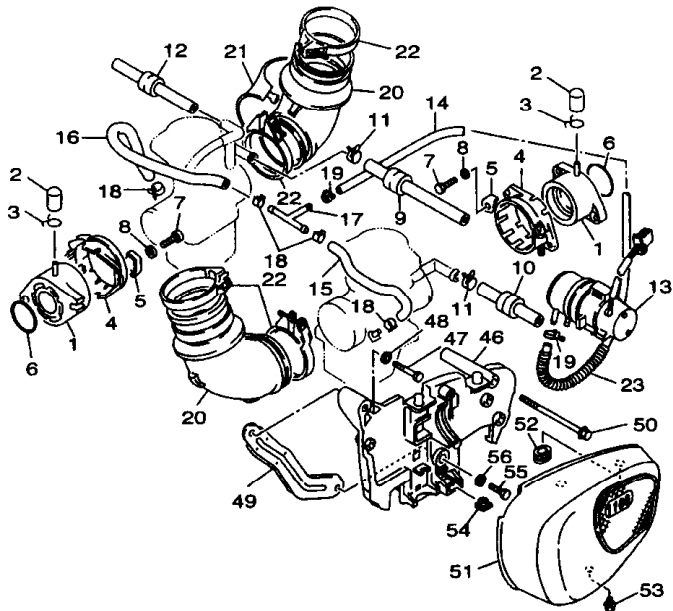
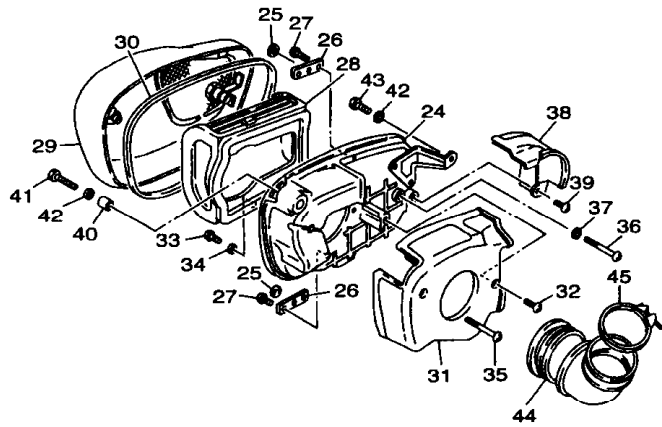

3LPE332-7080

FIG. 8 ADMISION

REF. NO.	CODIGO NO.	DESCRIPCION	3LPH				OBSERVACION
55	91317-06035	PERNO	1				
56	92907-06200	ARANDELA	1				

FIG. 9 CARBURADOR

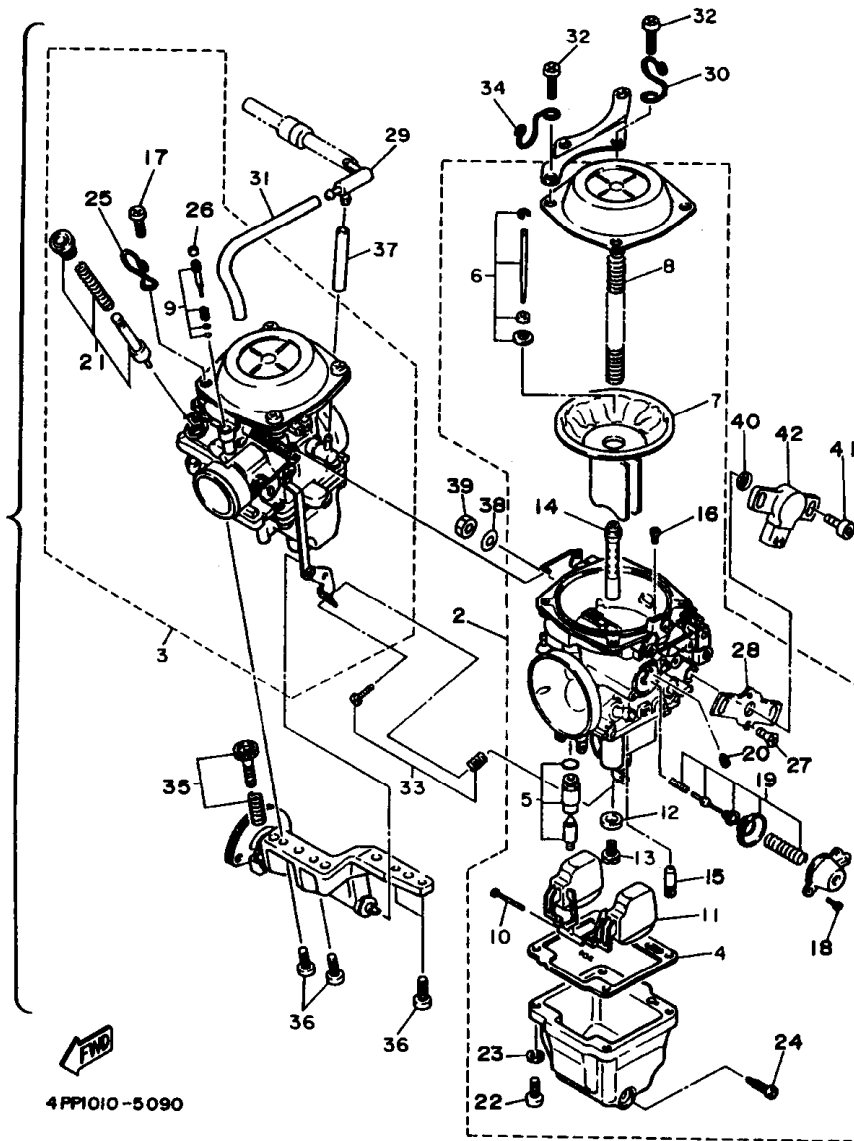

REF. NO.	CODIGO NO.	DESCRIPCION	SLPH				OBSERVACION
1	4PP-14900-01	CARBURADOR COMPLETO	1				
2	4PP-14901-01	..CARBURADOR COMPLETO 1	1				
3	4PP-14902-01	..CARBURADOR COMPLETO 2	1				
4	3CF-14984-01	..EMPAQUE CAMARA DE BOIA	1				
5	3CF-14107-15	..VALVULA DE AGUJA	1				
6	3CN-1490J-00	..CJTO. AGUJA	1				
7	4PP-14940-00	..DIAFRAGMA COMPLETO	1				
8	3CF-14933-00	..RESORTE DE DIAFRAGMA	1				
9	12R-14105-00	..TORNILLO DE PILOTO	1				
10	537-14186-00	..PASADOR DE LA BOYA	1				
11	2VA-14185-00	..BOYA	1				
12	137-14153-00	..ARANDELA SURTIDOR PPAL.	1				
13	620-1423A-75	..INYECTOR,PRINCIPAL (#122.5)	1				
14	3CF-14141-93	..BOQUILLA PRINCIPAL	1				
15	4G0-14142-40	..SURTIDOR DE RALENTI (# 40)	1				
16	3G2-14231-12	..INYECTOR,PRINCIPAL (# 60)	1				
17	98507-05010	..TORNILLO DE CABEZA CON PLAN	4				
18	98507-04008	..TORNILLO DE CABEZA CON PLAN	2				
19	3CF-1490H-00	..DIAFRAGMA	1				
20	1HX-14231-28	..INYECTOR,PRINCIPAL (#140)	1				
21	3CF-1410A-00	..JUEGO DE ARRANQUE	1				
22	98502-05016	..TORNILLO DE CABEZA CON PLAN	4				
23	92902-05100	..ARANDELA	4				
24	12R-14191-00	..TORNILLO, DE DRENAJE	1				
25	2JU-14937-00	..PRESILLA	1				
26	22F-14991-00	..TORNILLO	1				
27	98706-04008	..TORNILLO DE CABEZA PLANA	2				

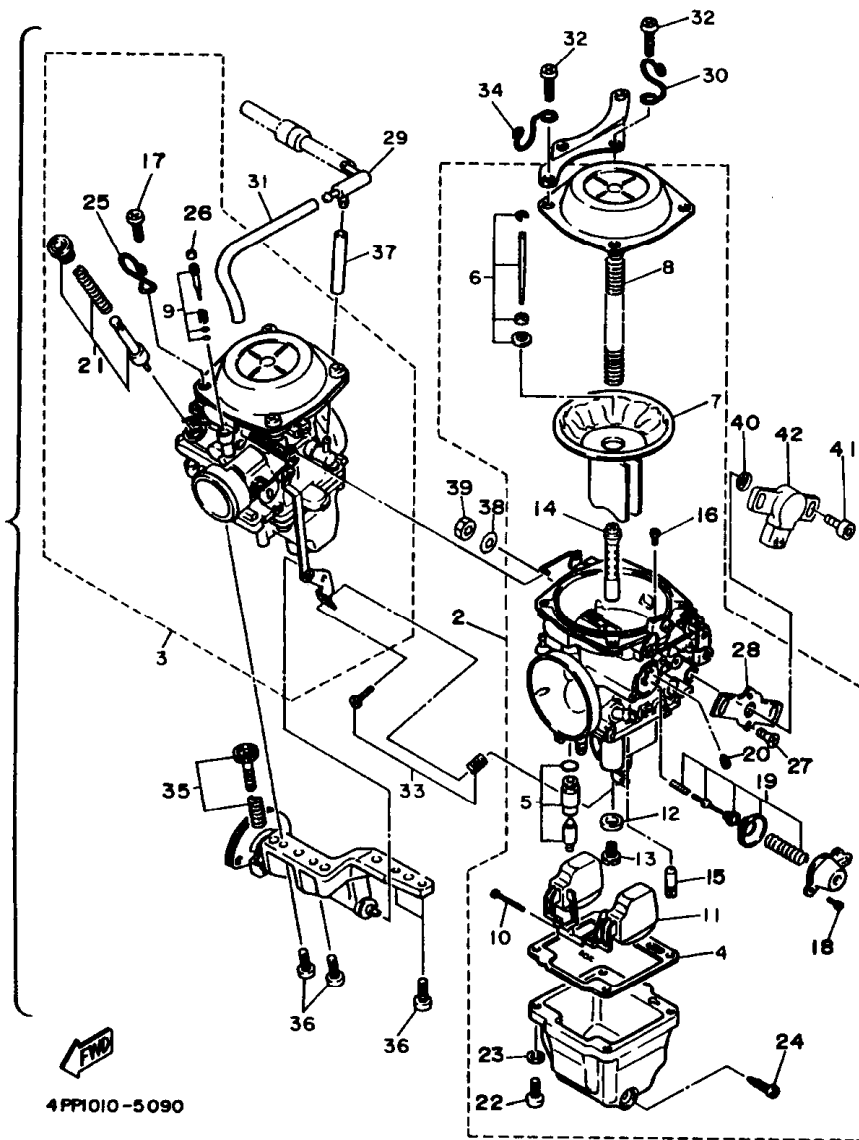
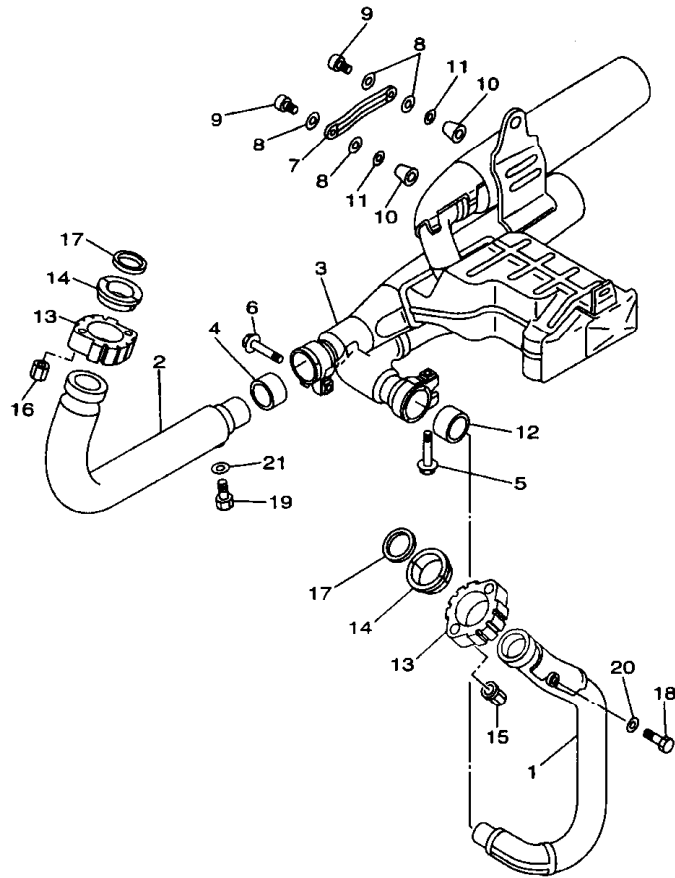

FIG. 9 CARBURADOR

REF. NO.	CODIGO NO.	DESCRIPCION	SLPH			OBSERVACION
28	4KG-14995-00	.SOPORTE	1			
29	3CF-14251-00	.NIPLE	1			
30	3CF-14937-00	.PRESILLA	1			
31	3CG-14197-00	.TUBO RESPIRADERO	1			
32	98507-05012	.TORNILLO DE CABEZA CON PLANA	4			
33	3CF-1490K-00	.JUEGO DE TORNILLOS DE TOPE	1			
34	3CF-14919-00	.PRESILLA	1			
35	3CF-14103-01	.CJTO. TORNILLO DEL RALENTI	1			
36	98507-05014	.TORNILLO DE CABEZA CON PLANA	4			
37	3CF-14197-00	.TUBO RESPIRADERO	1			
38	92907-08100	.ARANDELA	1			
39	812-14594-00	.TUERCA	1			
40	4HM-14239-00	.SELLO	1			
41	4HM-14216-00	.TORNILLO	2			
42	4HM-85885-10	.TERMICA SENSORIO	1			



FWD
3LPB332-6100

FIG. 10 DESCARGA

REF. NO.	CODIGO NO.	DESCRIPCION	3LPB				OBSERVACION
1	42H-14611-00	TUBO DE ESCAPE 1	1				
2	1TA-14621-00	TUBO DE ESCAPE 2	1				
3	3LP-14711-00	SILENCIADOR 1	1				
4	3YF-14755-00	EMPAQUE DE SILENCIADOR	1				
5	95027-08045	PERNO, DE BRIDA	1				
6	95027-08045	PERNO, DE BRIDA	1				
7	42X-14748-01	PROTECTOR DE SILENCIADOR 4	1				
8	4BD-14766-00	ARANDELA DE PROTECTOR	4				
9	98904-06010	TORNILLO DE LIGAR	2				
10	42X-1479H-00	CUBIERTA 1	2				
11	92907-06200	ARANDELA	2				
12	3EG-14714-00	EMPAQUE DE SILENCIADOR	1				
13	57A-14612-01	TUERCA ANILLO	2				
14	42X-1468A-00	ANILLO DE SILENCIADOR	2				
15	90179-08210	TUERCA	2				
16	90179-08673	TUERCA	2				
17	3EG-14613-00	JUNTA, TUBO DE ESCAPE	2				
18	90101-06576	TORNILLO	1				
19	90101-06576	TORNILLO	1				
20	92990-06600	ARANDELA	1				
21	92990-06600	ARANDELA	1				

FIG. 11 CARTER

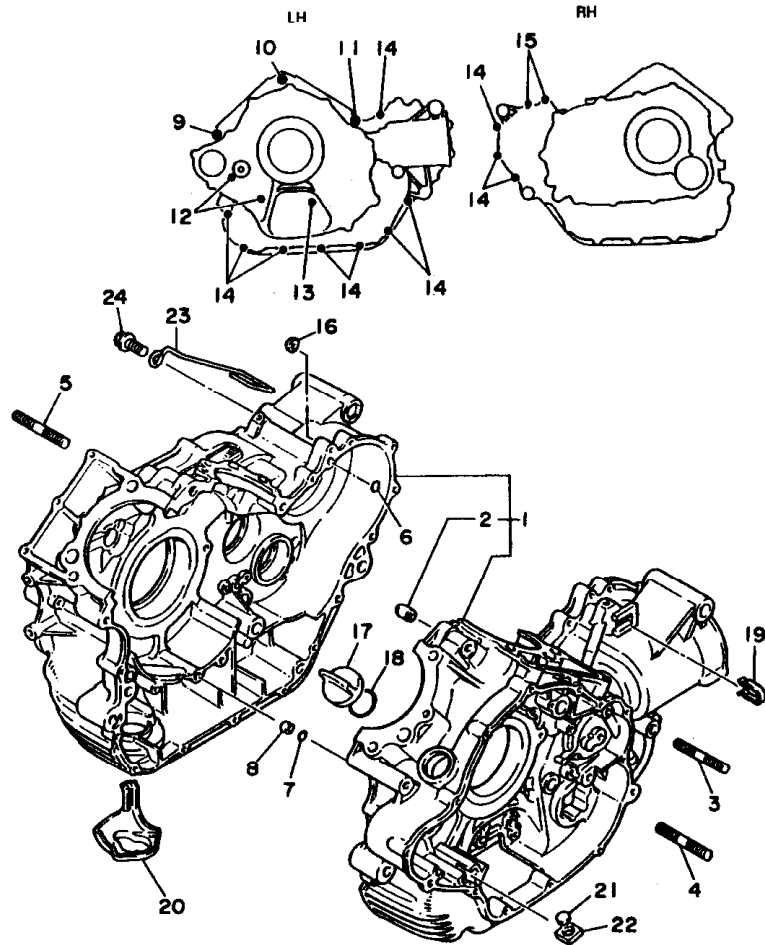

REF. NO.	CODIGO NO.	DESCRIPCION	3LPH				OBSERVACION
1	42H-15100-01	CARTER COMPLETO	1				
2	99530-14016	.PASADOR, DE ESPIGA	3				
3	95617-10620	PERNO DE PUNTAL	1				
4	95617-10620	PERNO DE PUNTAL	1				
5	95617-10670	PERNO DE PUNTAL	1				
6	93210-07135	ANILLO O	1				
7	93210-07135	ANILLO O	1				
8	90387-064E8	CASQUILLO CON VALONA	1				
9	91317-10100	PERNO	1				
10	91317-10070	PERNO	1				
11	91317-10060	PERNO	1				
12	91317-06080	PERNO	2				
13	91317-06055	PERNO	1				
14	91317-06030	PERNO	11				
15	91314-06030	PERNO	2				
16	90430-06014	JUNTA	1				
17	57A-15363-11	TAPON DE ACEITE	1				
18	93210-29198	ANILLO O	1				
19	90465-10168	BRIDA	1				
20	4X7-15491-00	PROTECTOR	1				
21	4X7-13419-00	TAPON	1				
22	90480-20302	TAPON	1				
23	42X-21164-00	SOSTEN DE CABLE	1				
24	90105-10275	TORNILLO CON ARANDELA	1				

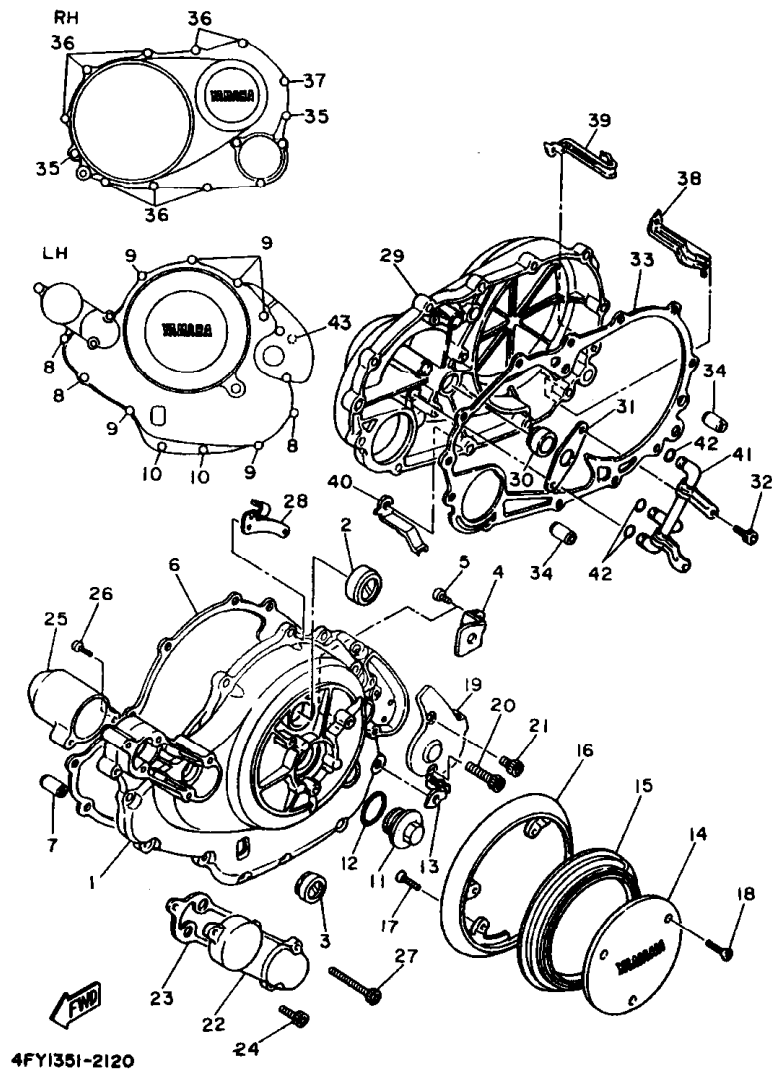

3LP7300-4110



4FYI351-2120

FIG. 12 CUBIERTA DE CARTER 1

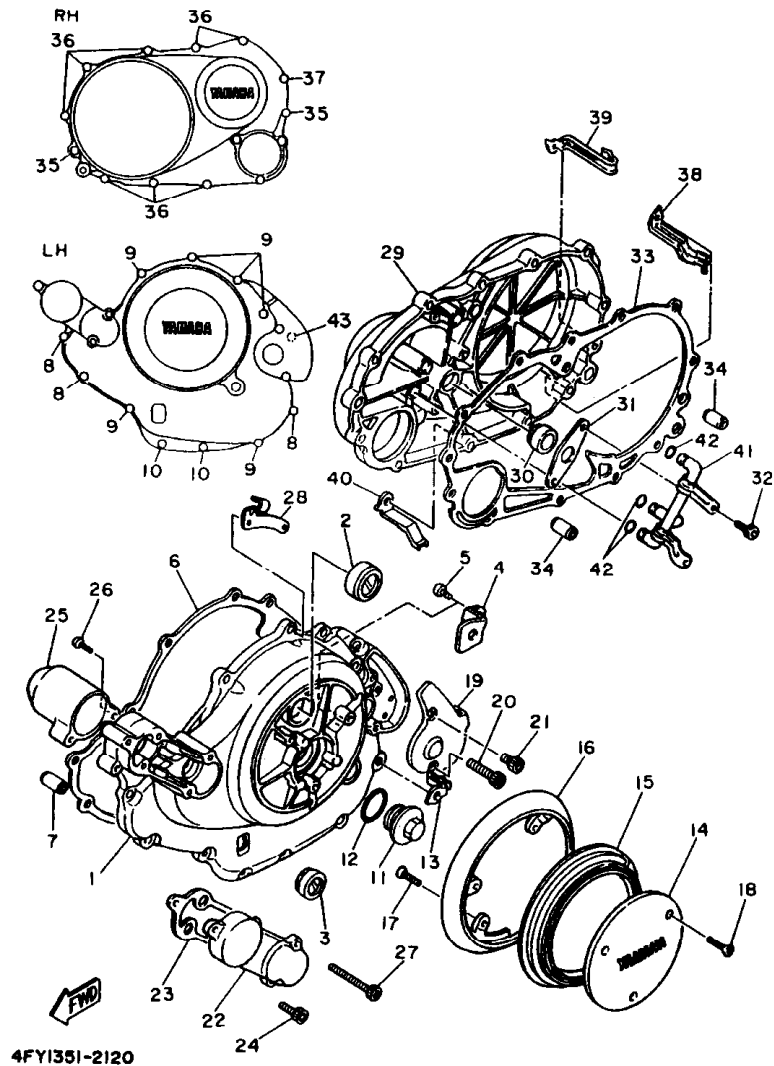
REF. NO.	CODIGO NO.	DESCRIPCION	ALPH				OBSERVACION
1	1RM-15411-01	CUBIERTA DE CARTER 1	1				
2	4X7-15361-00	MEDIDOR DE NIVEL	1				
3	2H7-15361-00	MEDIDOR DE NIVEL	1				
4	90465-08309	BRIDA	1				
5	98507-06010	TORNILLO DE CABEZA CON PLANA	1				
6	3EG-15451-00	EMPAQ DE CUBIERTA DE CARTER	1				
7	99530-10114	PASADOR, DE ESPIGA	2				
8	91314-06040	PERNO	3				
9	91314-06030	PERNO	6				
10	91314-06020	PERNO	2				
11	1L9-11186-00	CUBIERTA CULATA CIL.LAT.2	1				
12	93210-32172	ANILLO O	1				
13	90462-08076	BRIDA	1				
14	1RM-15415-01	CUBIERTA DE GENERADOR	1				
15	1RM-15455-00	EMPAQUE 1	1				
16	3JK-15425-00	CUBIERTA DE GENERADOR 2	1				
17	98704-06016	TORNILLO DE CABEZA PLANA	3				
18	98707-06014	TORNILLO DE CABEZA PLANA	3				
19	42X-15417-01	CUBIERTA DE TAPA	1				
20	91314-06055	PERNO	1				
21	91314-06016	PERNO	1				
22	1RM-15419-00	CUBIERTA DE SELECCIONADOR	1				
23	3EG-15459-00	EMPAQ CUBIERTA DE CAMBIADOR	1				
24	91314-06016	PERNO	2				
25	5A8-15429-00	TAPA	1				
26	98507-06030	TORNILLO DE CABEZA CON PLANA	2				
27	91314-06065	PERNO	1				



4FY1351-2120

FIG. 12 CUBIERTA DE CARTER 1

REF. NO.	CODIGO NO.	DESCRIPCION	SL/PL				OBSERVACION
28	42X-15441-00	SOSTEN DE CABLE DE EMBRAGUE	1				
29	3JK-W1542-01	CUBIERTA DE CARTER 3	1				
30	93101-14102	SELLO ACEITE	1				
31	4X7-15388-00	PLACA DE CUBIERTA DE COJINETE	1				
32	91317-06016	PERNO	2				
33	3EG-15462-00	EMPAQ CUBIERTA DE CARTER 3	1				
34	99530-10120	PASADOR, DE ESPIGA	2				
35	91314-06040	PERNO	2				
36	91314-06025	PERNO	8				
37	91380-06030	PERNO	1				
38	90462-10143	BRIDA	1				
39	90462-10085	BRIDA	2				
40	90462-12142	BRIDA	1				
41	1RM-13161-00	TUBO CONDUCTOR 1	1				
42	93210-07135	ANILLO O	3				
43	90110-06093	TORNILLO ALLEN	1				

FIG. 13 EMBRAG. DEL ARRANQUE

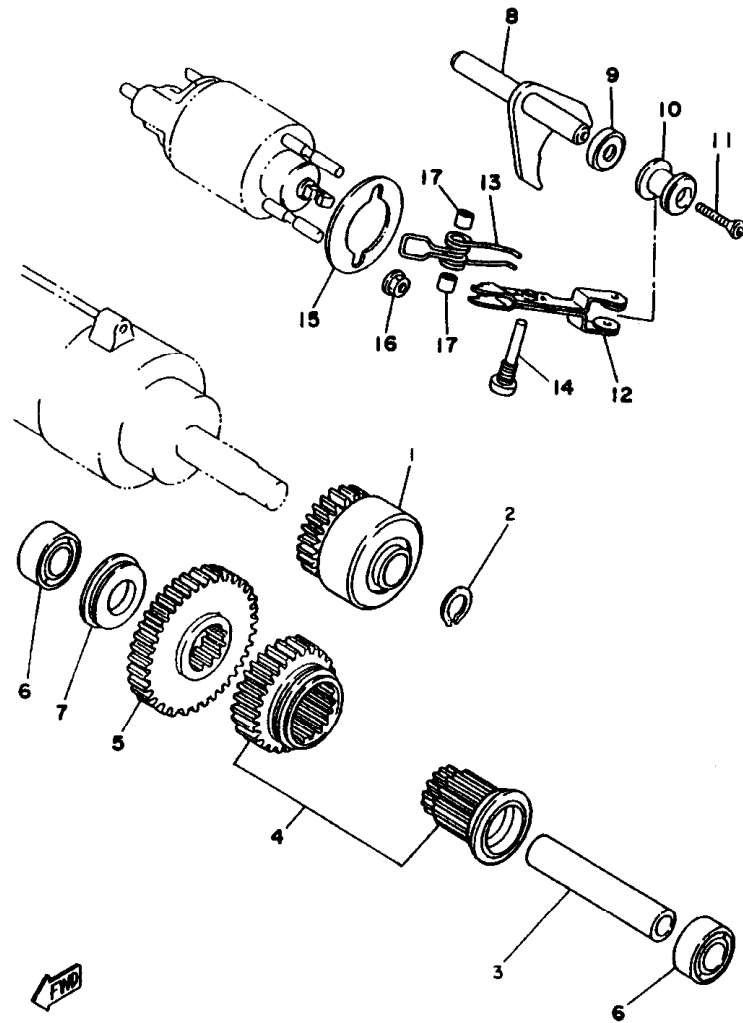

4PW3332-6130

REF. NO.	CODIGO NO.	DESCRIPCION	3LPH				OBSERVACION
1	3LP-15570-00	EMBRAGUE DEL ARRANQUE COMPLETA	1				
2	99009-13400	PRESILLA REDONDA	1				
3	4X7-15521-00	EJE 1	1				
4	3LP-W1551-00	JUEGO DE ENGRENAJE POSICION	1				
5	1TA-15512-00	ENGRENAJE NEUTRO	1				
6	90387-172E5	CASQUILLO CON VALONA	2				
7	90387-170E5	CASQUILLO CON VALONA	1				
8	5A8-15550-00	PALANCA DE TRACCION COMPLETA	1				
9	93102-10247	SELLO ACEITE	1				
10	5A8-15542-01	COLLAR 2	1				
11	90151-06013	TORNILLO EMBUTIDO	1				
12	5A8-15556-00	PALANCA DE TRACCION	1				
13	90508-26494	RESORTE DE TORSION	1				
14	90149-08166	TORNILLO DE REGLAJE	1				
15	3EG-15568-00	EMPAQUE	1				
16	95707-06500	TUERCA DE BRIDA	2				
17	90387-0801M	CASQUILLO CON VALONA	2				

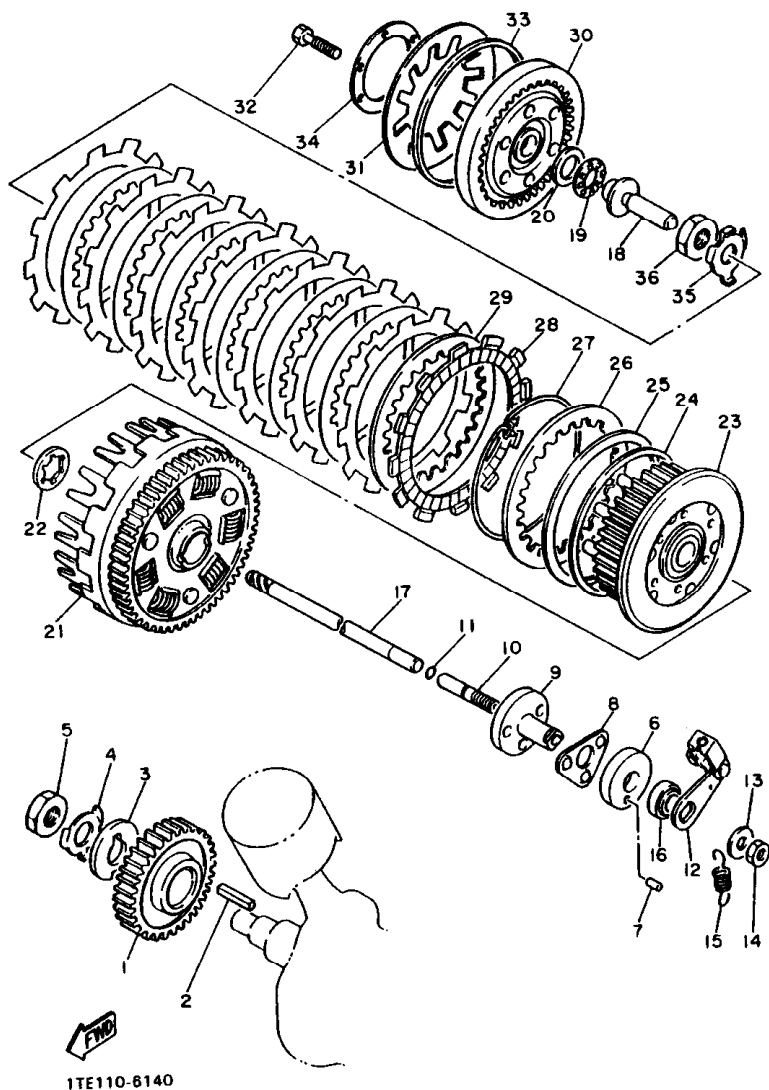
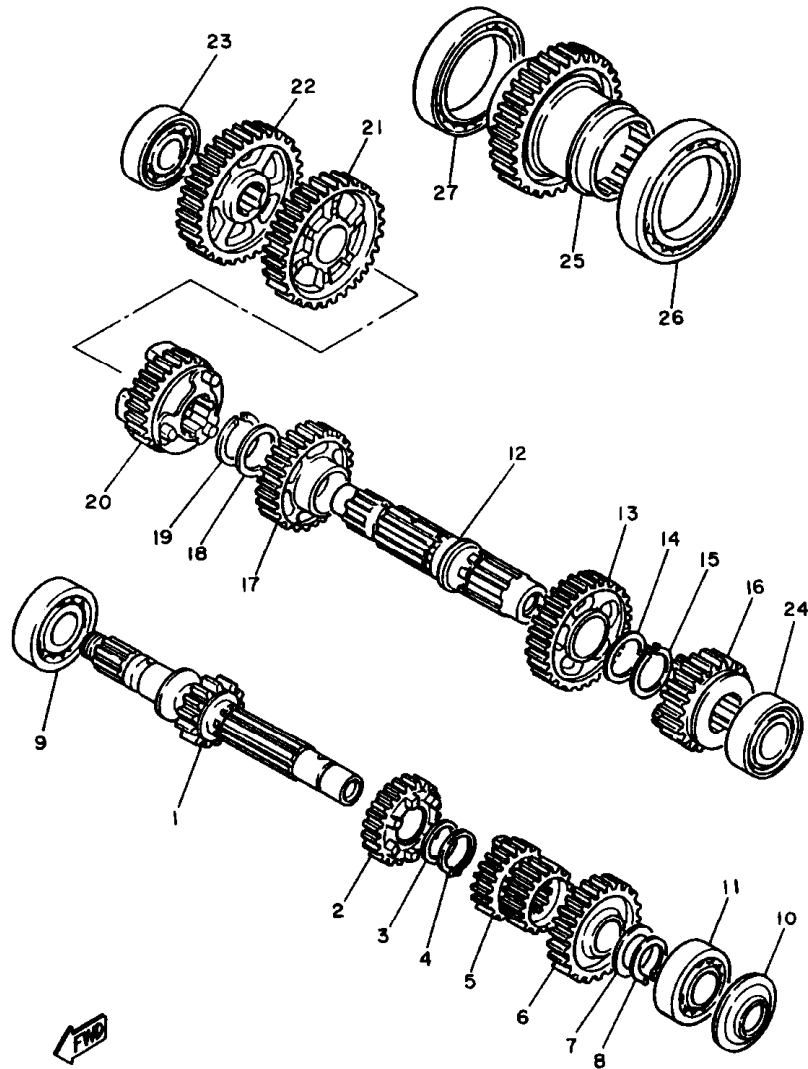

FIG. 14 EMBRAGUE

REF. NO.	CODIGO NO.	DESCRIPCION	3LPH				OBSERVACION
1	4X7-16111-00	ENGRANAJE TRACC.PRIMARIA (47T)	1				
2	90282-07042	CHAVETA, RECTA	1				
3	90214-20022	ARANDELA DE POSICION	1				
4	90215-20182	ARANDELA DE CIERRE	1				
5	90170-20274	TUERCA	1				
6	2H7-16396-00	CAJA DE TORNILLO DE EMPUJE	1				
7	93606-07082	PASADOR DE CLAVIJA	1				
8	2H7-16395-01	RETEN DE BOLA	1				
9	2H7-16341-00	TORNILLO DE EMPUJE	1				
10	2H7-16343-00	TORNILLO DE AJUSTE	1				
11	93210-48364	ANILLO O	1				
12	4X7-16340-00	PALANCA DE EMPUJE COMPLETA	1				
13	92907-08200	ARANDELA	1				
14	95307-08700	TUERCA	1				
15	90506-10069	RESORTE DE TENSION	1				
16	93104-14059	SELLO ACEITE	1				
17	4X7-16357-00	VARILLA DE EMPUJE 2	1				
18	4X7-16356-00	VARILLA DE EMPUJE 1	1				
19	93340-21505	COJINETE	1				
20	90201-151A7	ARANDELA PLANA	1				
21	4X7-16150-02	CAMPANA DE EMBRAGUE	1				
22	3Y1-16154-00	ARANDELA, DE EMPUJE 1	1				
23	1TA-16371-00	CUBO, DE EMBRAGUE	1				
24	4X7-16384-00	PLACA DE ASIENTO	1				
25	4X7-16383-01	RESORTE DE COPA DE EMBRAGUE	1				
26	4X7-16324-00	PLACA DE EMBRAGUE	1				
27	4X7-16385-00	RESORTE DE COPA DE EMBRAGUE	1				

FIG. 15 TRANSMISION



FWD
5E3171-1170

REF. NO.	CODIGO NO.	DESCRIPCION	SLPH				OBSERVACION
1	1TA-17411-00	EJE PRIMARIO	1				
2	4X7-17141-00	ENGRANAJE PINONDE 4TA (31T)	1				
3	90209-22191	ARANDELA DE SEPARACION	1				
4	99009-25400	PRESILLA REDONDA	1				
5	4X7-17121-00	ENGRANAJE DE PINON DE 2DA	1				
6	42X-17151-00	ENGRANAJE PINON DE5TA(34T)	1				
7	90201-20276	ARANDELA, PLACA(1.0T)	1				
8	99009-20400	PRESILLA REDONDA	1				
9	93306-30525	COJINETE (B6305)	1				
10	93104-20068	SELLO ACEITE	1				
11	93306-30424	COJINETE (B6304A3)	1				
12	4X7-17402-00	EJE DE TRACCION COMPLETO	1				
13	4X7-17221-00	ENGRANAJE RUEDA DE 2DA (40T)	1				
14	90209-27192	ARANDELA DE SEPARACION	1				
15	93440-30077	BOLA	1				
16	42X-17251-00	ENGRANAJE RUEDA DE 5TA (29T)	1				
17	4X7-17231-00	ENGRANAJE RUEDA DE 3RA (36T)	1				
18	90209-27192	ARANDELA DE SEPARACION	1				
19	93440-30077	BOLA	1				
20	4X7-17241-00	ENGRANAJE DE RUEDA 4TA (32T)	1				
21	1TA-17211-00	ENGRANAJE RUEDA DE 1RA (39T)	1				
22	4PP-17582-00	ENGRANAJE MEDIO DE TRACCION	1				
23	93306-20401	COJINETE (B6204)	1				
24	93306-20550	COJINETE (B6205DU8)	1				
25	4PP-17583-00	ENGRANAJE MEDIO DE IMPULSION	1				
26	93316-01201	COJINETE (B16012)	1				
27	93306-91201	COJINETE (B6912)	1				

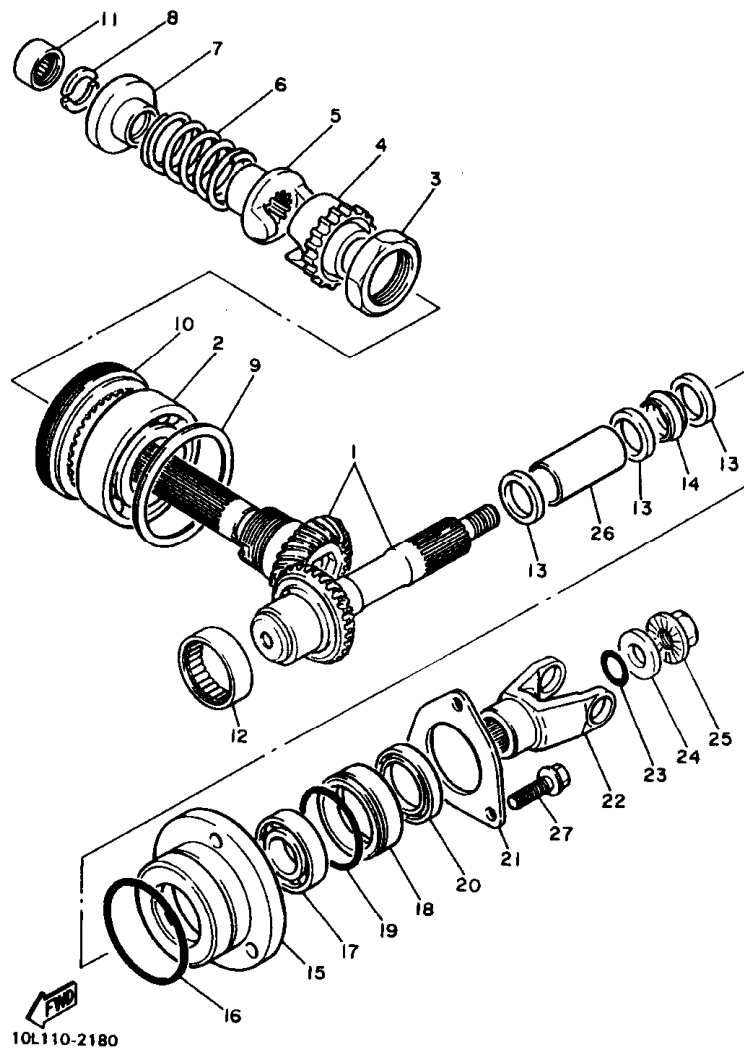
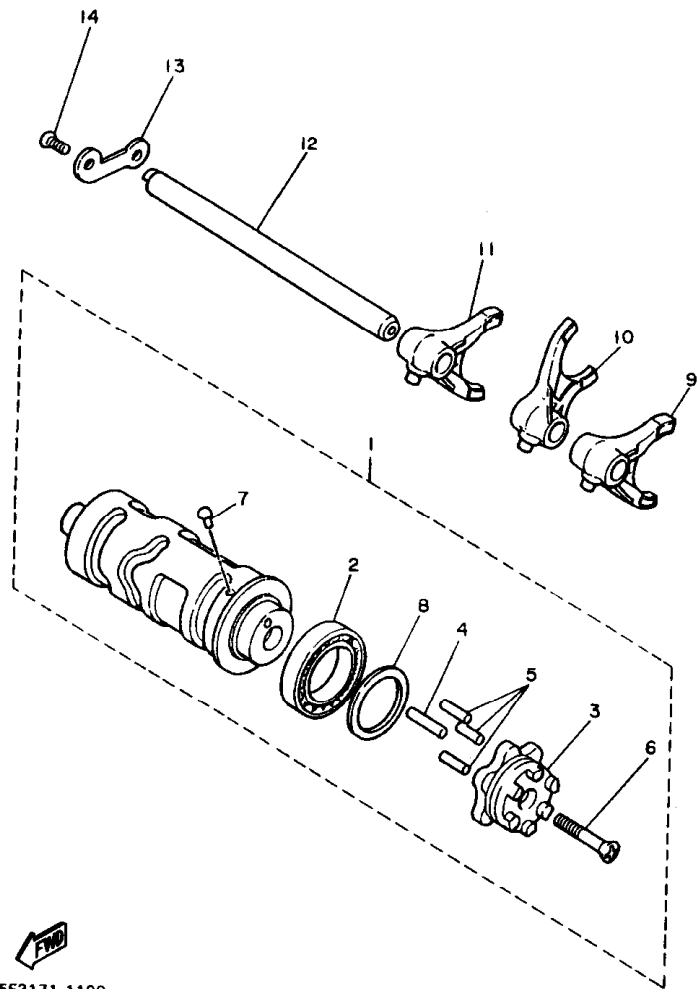

FIG. 16 ENGR. MEDIO DE TRAC.

REF. NO.	CODIGO NO.	DESCRIPCION	ALPH	OBSERVACION
1	1TA-Y1757-00	ENGRANAJE MEDIO COMPLETE	1	
2	93306-20901	COJINETE (B6209RSH2-C2)	1	
3	90179-44328	TUERCA	1	
4	42X-17526-01	LEVA DE TRACCION	1	
5	31A-17527-00	LEVA DE IMPULSION	1	
6	90501-70762	RESORTE DE COMPRESION	1	
7	4X7-17524-00	SOSTEN	1	
8	3H5-17529-00	ARANDELA DE EMPUJE	2	
9	4X7-17531-00-15	CUNA DE PINON (0.15T)	1	UR
	4X7-17531-00-30	CUNA DE PINON (0.30T)	1	UR
	4X7-17531-00-50	CUNA DE PINON (0.50T)	1	UR
10	90179-88336	TUERCA	1	
11	93317-22021	COJINETE	1	
12	93311-44051	COJINETE	1	
13	90201-255A6	ARANDELA PLANA	3	
14	1J7-46129-Y1	ESPACIADOR DE EXPANSION	1	
15	4X7-17551-00	CAJA DE COJINETE	1	
16	93210-71360	ANILLO O	1	
17	93306-20548	COJINETE (B6205RC2)	1	
18	4X7-17554-00	RETEN DE COJINETE	1	
19	93210-52449	ANILLO O	1	
20	93101-35099	SELLO ACEITE	1	
21	4X7-17558-00	PLACA	1	
22	4X7-17556-00	YUGO DE ARTICULACION	1	
23	93210-14359	ANILLO O	1	
24	90201-14633	ARANDELA PLANA	1	
25	90179-14317	TUERCA	1	



 5E3171-1190

FIG. 17 LEVA DE CAMBIO. HORQ

REF. NO.	CODIGO NO.	DESCRIPCION	3LPH				OBSERVACION
1	4X7-18540-01	LEVADEL CAMBIO COMPLETA	1				
2	93306-90602	.COJINETE	1				
3	4G0-18185-01	.SEGMENTO DE RETENCION	1				
4	93604-20156	.PASADOR DE CLAVIJA	1				
5	93604-18092	.PASADOR DE CLAVIJA	3				
6	98701-05035	.TORNILLO DE CABEZA PLANA	1				
7	136-18542-00	.PUNTO MVERTO	1				
8	90201-30297	.ARANDELA PLANA	1				
9	4X7-18511-00	HORQUILLA DEL CAMBIO 1	1				
10	4X7-18512-00	HORQUILLA DEL CAMBIO 2	1				
11	4X7-18513-00	HORQUILLA DE CAMBIO 3	1				
12	4X7-18531-00	BARRA GUIA HORQ. CAMBIO 1	1				
13	4X7-18536-00	TOPE DE PALANCA SELECTOR	1				
14	90151-06041	TORNILLO EMBUTIDO	2				

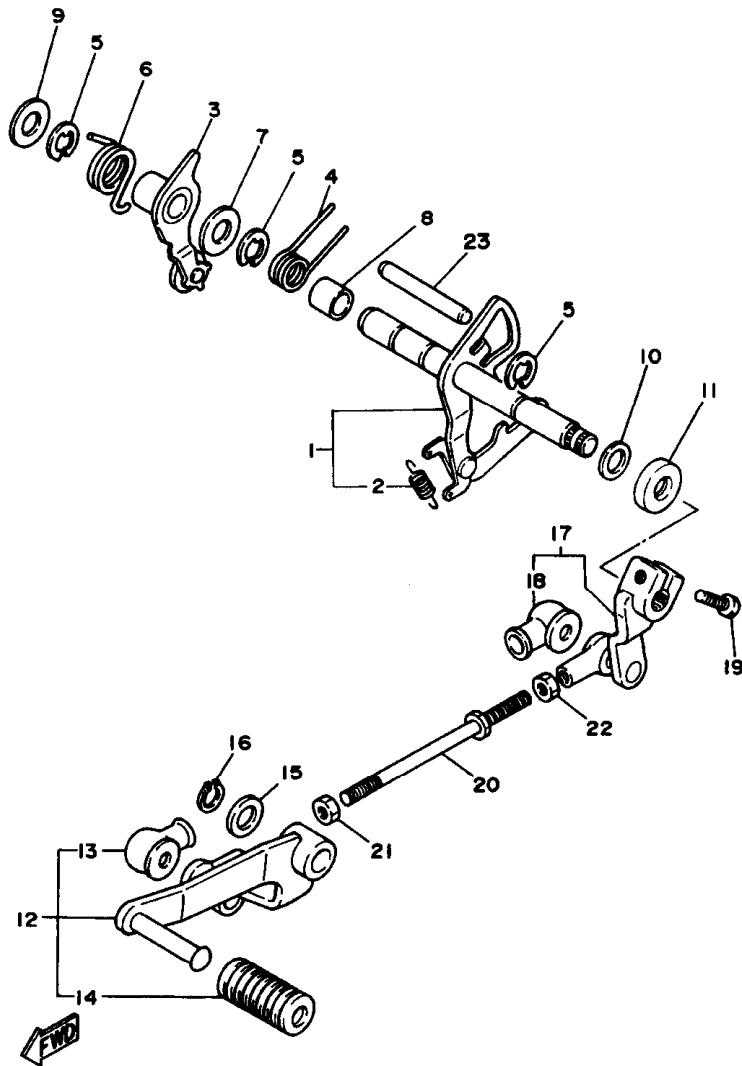

3EF2361-9180

FIG. 18 EJE DE CAMBIO. PEDAL

REF. NO.	CODIGO NO.	DESCRIPCION	3LPH			OBSERVACION
1	4X7-18120-01	PALANCA DE SELECTOR COMPLETO	1			
2	90506-08227	.RESORTE DE TENSION	1			
3	4X7-18140-00	PALANCA DE TOPE COMPLETA	1			
4	90508-32535	RESORTE DE TORSION	1			
5	99001-10600	PRESILLA REDONDA	3			
6	90508-29531	RESORTE DE TORSION	1			
7	90201-12588	ARANDELA PLANA	1			
8	90387-124F4	CASQUILLO CON VALONA	1			
9	90201-12588	ARANDELA PLANA	1			
10	90201-12166	ARANDELA PLANA	1			
11	93102-12106	SELLO ACEITE (SD 12-22-5 HS)	1			
12	42X-18110-01	PEDAL DE CAMBIO COMPLETO	1			
13	2H9-18154-00	.CUBIERTA GUARDAPOLVO	1			
14	132-18113-01	.FUNDA DEL PEDAL DEL CAMBIO	1			
15	90201-12688	ARANDELA PLANA	1			
16	99009-12400	PRESILLA REDONDA	1			
17	42X-18112-01	BRAZO DEL CANBIO	1			
18	2H9-18154-00	.CUBIERTA GUARDAPOLVO	1			
19	97024-06020	PERNO	1			
20	29L-18115-00	VARILLA DEL CANBIO	1			
21	90170-06228	TUERCA	1			
22	95304-06700	TUERCA	1			
23	93608-50158	PASADOR DE CLAVIJA	1			

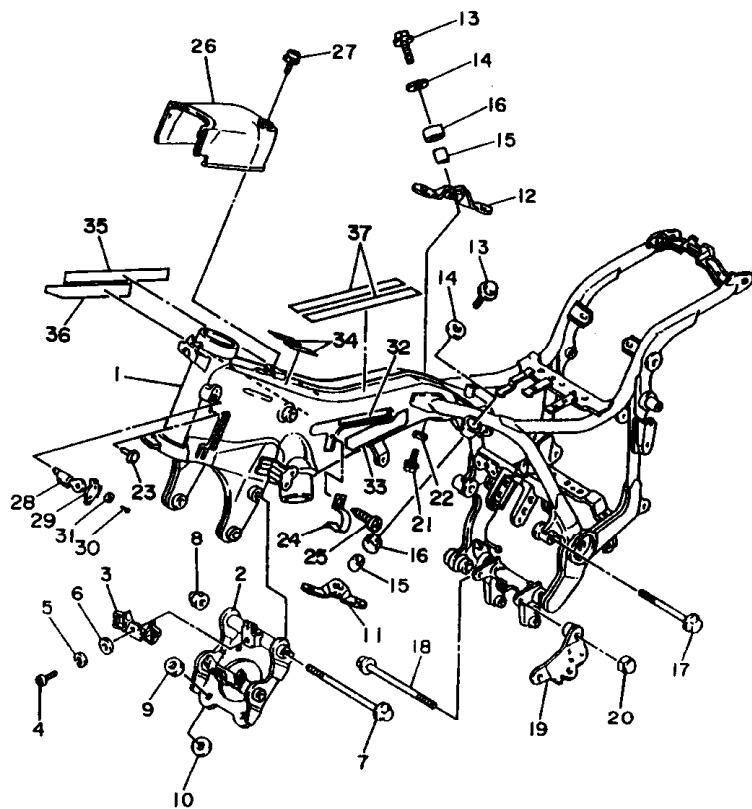

4PW1332-5190

FIG. 19 CUADRO

REF. NO.	CODIGO NO.	DESCRIPCION	SUPH			OBSERVACION
1	2EM-21110-00-33	ARMAZON COMPLETO	1			YB
2	42X-21317-00	SOPORTE DE MOTOR 3	1			
3	42X-21359-00	SOPORTE DE BOBINA	1			
4	98507-06012	TORNILLO DE CABEZA CON PLANA	1			
5	92907-06100	ARANDELA	1			
6	92907-06600	ARANDELA	1			
7	90105-10297	TORNILLO CON ARANDELA	2			
8	90176-10075	TUERCA CORONA	2			
9	90179-12657	TUERCA	4			
10	90201-125A3	ARANDELA PLANA	4			
11	42X-21315-01	SOPORTE DE MOTOR 2	1			
12	42X-21316-01	SOPORTE DE MOTOR 3	1			
13	90105-10298	TORNILLO CON ARANDELA	2			
14	90201-105H3	ARANDELA PLANA	2			
15	90387-100E2	CASQUILLO CON VALONA	2			
16	4X7-21485-00	AMORTIGUADOR DE GOMA 1	2			
17	90105-10299	TORNILLO CON ARANDELA	2			
18	90105-10300	TORNILLO CON ARANDELA	1			
19	42X-21458-01	SOPORTE DE PUNTAL LATERAL	1			
20	90176-10075	TUERCA CORONA	2			
21	90105-06069	TORNILLO CON ARANDELA	1			
22	90202-05193	ARANDELA DE PLANA	1			
23	90338-07043	TAPON	2			
24	90462-08138	BRIDA	2			
25	97707-50508	TORNILLO ROSCA HEMBRA	2			
26	42X-2139R-00	CUBIERTA 2	1			
27	90159-06058	TORNILLO CON VALONA	1			

FIG. 20 GUARDABARRO

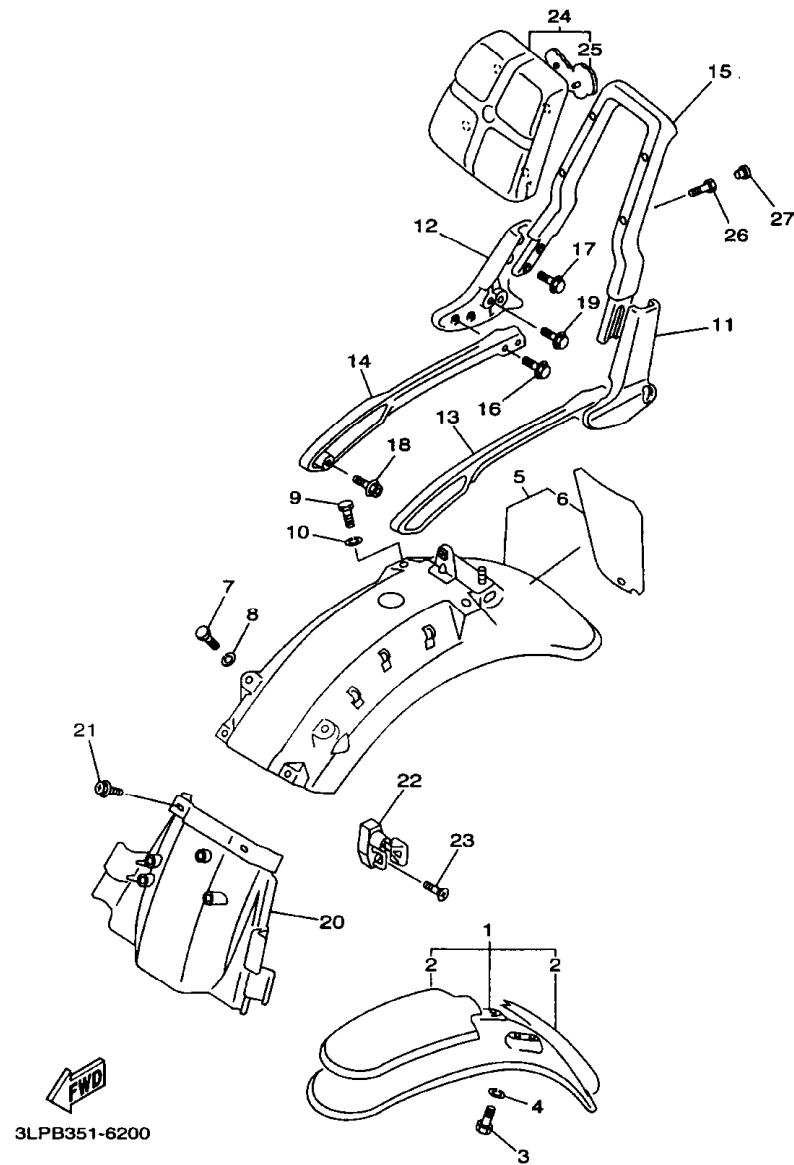

REF. NO.	CODIGO NO.	DESCRIPCION	3LPH			OBSERVACION
1	1MY-Y2151-N0-9B	GUARDABARRO DELANTERO COMPL.	1			UR DNBM1
	1MY-Y2151-K0-JY	GUARDABARRO DELANTERO COMPL.	1			UR MYM
2	3JK-21570-F0	.CALCOMANIAS GUARDABARRO DEL.	1			UR PARA DNBM1
	3JK-21570-E0	.CALCOMANIAS GUARDABARRO DEL.	1			UR PARA MYM
3	97027-06012	PERNO	4			
4	92907-06100	ARANDELA	4			
5	1RM-Y2161-1X-9B	GUARDABARRO TRASERO COMPLETO	1			UR DNBM1
	1RM-Y2161-1Y-JY	GUARDABARRO TRASERO COMPLETO	1			UR MYM
6	3JK-21675-D0	.JUEGO DE EMBLEMA	1			UR PARA MYM
	3JK-21675-E0	.JUEGO DE EMBLEMA	1			UR PARA DNBM1
7	97027-06012	PERNO	2			
8	92907-06100	ARANDELA	2			
9	97027-08012	PERNO	2			
10	92907-08100	ARANDELA	2			
11	1RM-2164F-00	APOYO 1	1			
12	1RM-2164G-00	APOYO 2	1			
13	3JK-2164H-00	APOYO 3	1			
14	3JK-2164J-00	APOYO 4	1			
15	42H-2164A-02	EMPUNADURA 1	1			
16	95817-06016	TUERCA DE REBORDE	4			
17	95827-06016	TUERCA DE REBORDE	4			
18	90149-08225	TORNILLO DE REGLAJE	2			
19	90105-10217	TORNILLO CON ARANDELA	2			
20	42X-21629-00	GUARDABARRO INFERIOR	1			
21	90159-06128	TORNILLO CON VALONA	2			
22	4R8-21308-00	PORTACASCÓ COMPLETO	1			
23	90149-06154	TORNILLO DE REGLAJE	1			

FIG. 20 GUARDABARRO

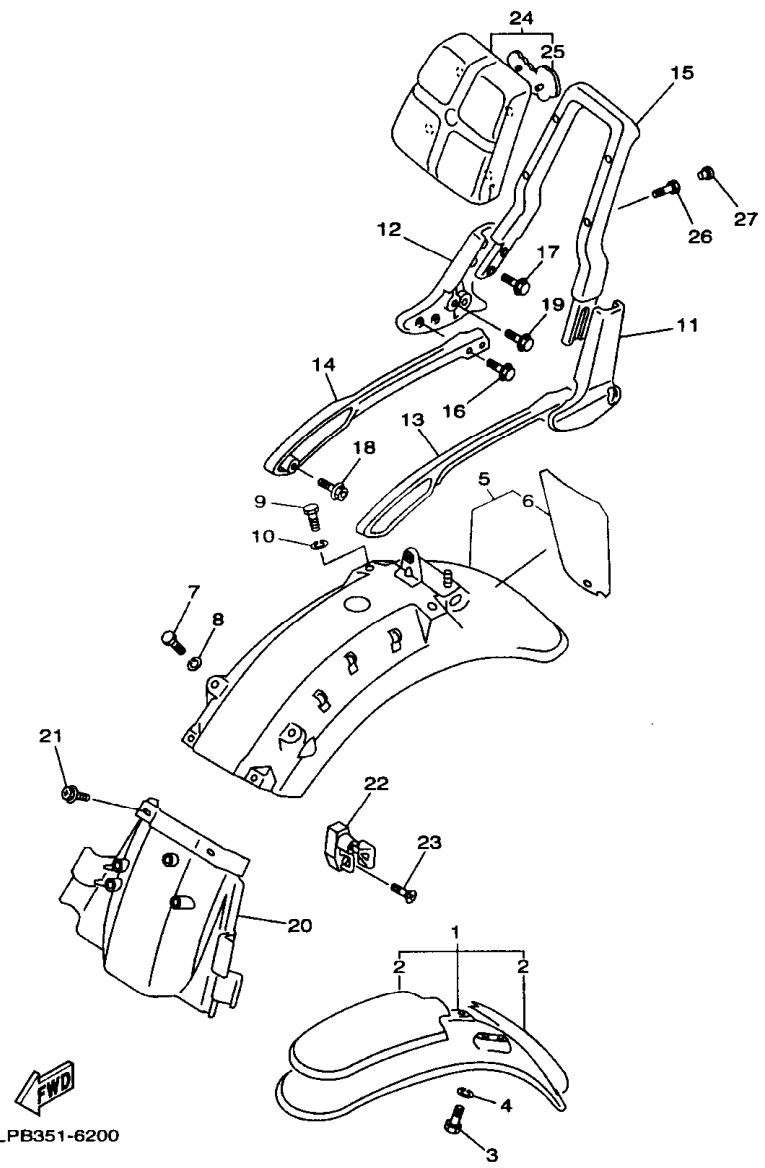

REF. NO.	CODIGO NO.	DESCRIPCION	3LPH				OBSERVACION
24	1TA-2840F-00	COJIN DEL RESPALDO	1				
25	42H-24786-00	.EMBLEMA	1				
26	91317-06035	PERNO	4				
27	90338-06162	TAPON	4				

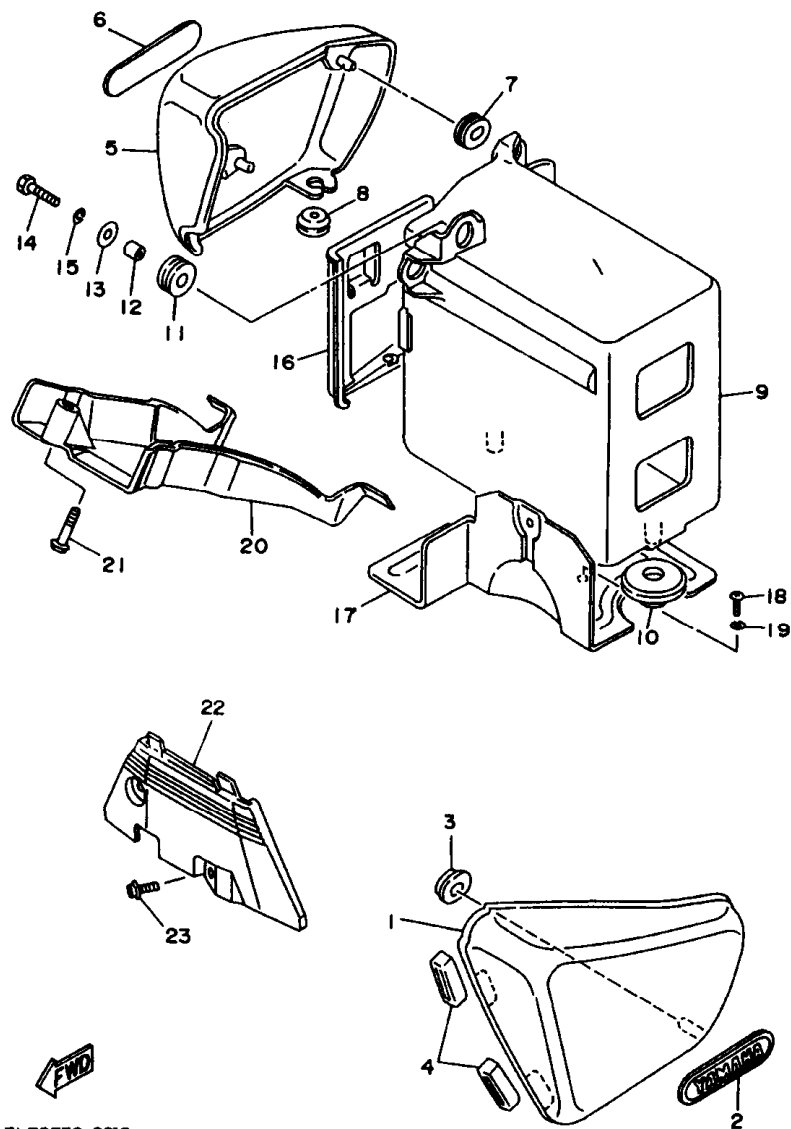

3LP8332-6210

FIG. 21 CUBIERTA LATERAL

REF. NO.	CODIGO NO.	DESCRIPCION	3LPH			OBSERVACION
1	42X-21711-00-9B	TAPA LATERAL 1	1			UR DNBM1
	42X-21711-00-JY	TAPA LATERAL 1	1			UR MYM
2	3LS-21781-00	EMBLEMA 1	1			
3	90480-01141	TAPON	1			
4	3LP-21717-00	AMORTIGUADOR	2			
5	42X-21721-00-9B	TAPA LATERAL 2	1			UR DNBM1
	42X-21721-00-JY	TAPA LATERAL 2	1			UR MYM
6	3LS-21781-00	EMBLEMA 1	1			
7	90480-01141	TAPON	2			
8	90480-12053	TAPON	1			
9	42X-21171-00	CAJA	1			
10	90480-20384	TAPON	2			
11	90480-16233	TAPON	1			
12	90387-07674	CASQUILLO CON VALONA	1			
13	90201-06380	ARANDELA PLANA	1			
14	97007-06020	PERNO	1			
15	92907-06100	ARANDELA	1			
16	42X-28185-00	TAPA	1			
17	42X-2172W-02	CUBIERTA	1			
18	98507-06010	TORNILLO DE CABEZA CON PLANA	2			
19	92907-06100	ARANDELA	2			
20	42X-2176E-00	PLACA	1			
21	90159-06110	TORNILLO CON VALONA	1			
22	42X-2117F-00	CUBIERTA	1			
23	90159-06033	TORNILLO CON VALONA	2			

FIG. 22 BRAZO TRASERO. SUSPENSION

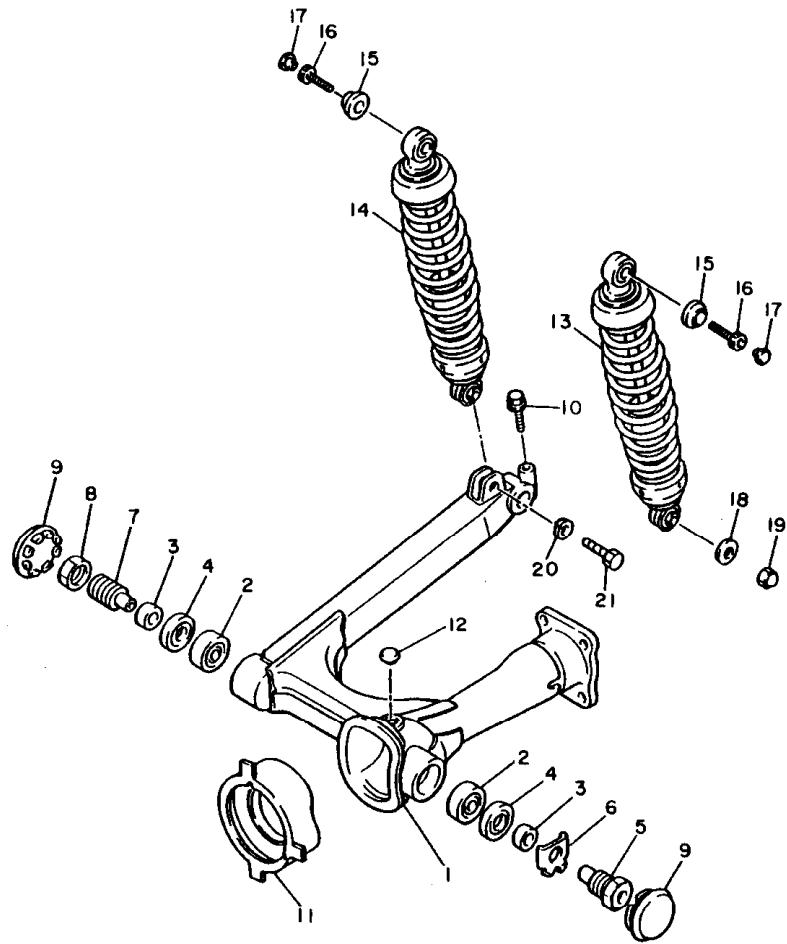

REF. NO.	CODIGO NO.	DESCRIPCION	SLPH				OBSERVACION
1	1RM-22110-01-35	BRAZO TRASERO COMPLETO	1				SL
2	93332-00010	COJINETE	2				
3	90387-17543	CASQUILLO CON VALONA	2				
4	93102-25017	SELLO ACEITE	2				
5	42X-22141-00	EJE DEL BARCULANTE	1				
6	90215-22238	ARANDELA DE CIERRE	1				
7	1J7-22141-00	EJE DEL BARCULANTE	1				
8	1J7-22143-00	TUERCA	1				
9	2H7-2219X-00	CUBIERTA	2				
10	95024-08035	PERNO, DE BRIDA	1				
11	4X7-22189-01	FUNDA DE GOMA	1				
12	90338-20113	TAPON	1				
13	3JK-22210-10	AMORTIGUADOR TRASERO COMPLETO	1				
14	3JK-22220-10	AMORTIGUADOR TRASERO COMPLETO	1				
15	57A-22243-01	ARANDELA 1	2				
16	91317-08020	PERNO	2				
17	90338-08163	TAPON	2				
18	90201-105R9	ARANDELA PLANA	1				
19	90176-10073	TUERCA CORONA	1				
20	92903-10100	ARANDELA	1				
21	90106-10052	PERNO	1				

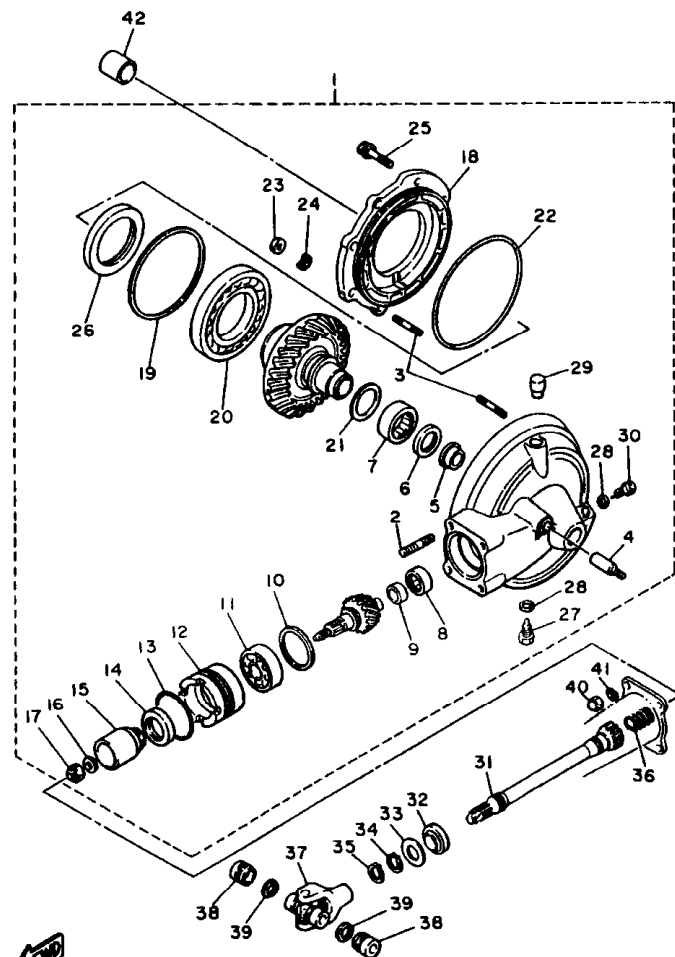

 3CF110-8220



1TE110-8230

FIG. 23 EJE DE TRACCION

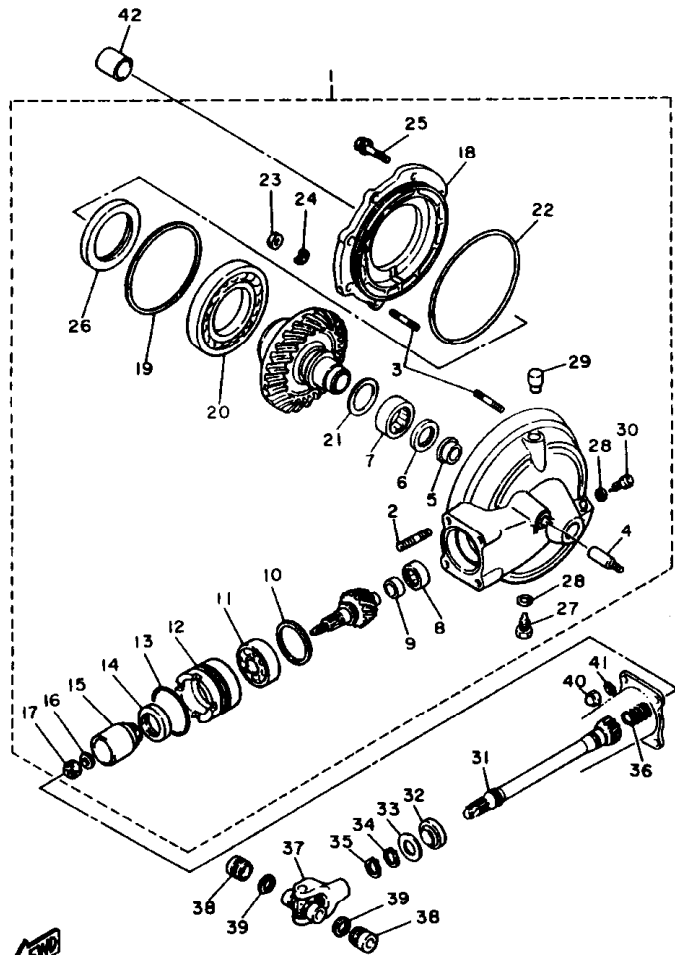
REF. NO.	CODIGO NO.	DESCRIPCION	ALPH		OBSERVACION
1	56W-46101-02	CAJA ENGRANAJE EJE TRAS COMPL	1		
2	90116-10362	.ESPARRAGO	4		
3	90116-08360	.ESPARRAGO	6		
4	90116-10249	.ESPARRAGO	1		
5	4H7-46153-00	.COLLAR DE GUIA	1		
6	93101-30084	.SELLO ACEITE	1		
7	93311-43729	.COJINETE	1		
8	93317-41510	.COJINETE	1		
9	2H7-46122-00	.CARRERA INTERIOR	1		
10	1J7-17537-Y0-30	.CUNA DE EMPUJE (0.30T)	1		UR
	1J7-17537-Y0-40	.CUNA DE EMPUJE (0.40T)	1		UR
	1J7-17537-Y0-50	.CUNA DE EMPUJE (0.50T)	1		UR
11	93306-30533	.COJINETE (B6305RB1)	1		
12	4H7-46125-00	.RETEN DE COJINETE	1		
13	93210-60426	.ANILLO O	1		
14	93101-38098	.SELLO ACEITE	1		
15	4H7-46123-00	.ACOPLAMIENTO DE ENGRANAJE	1		
16	90201-14632	.ARANDELA PLANA	1		
17	90185-14070	.TUERCA AUTOBLOCANTE	1		
18	4H7-46152-00	.CAJA DE COJINETE	1		
19	1J7-46117-Y0-30	.CUNA ENGRANAJE DE ANILLO (0.3	1		UR
	1J7-46117-Y0-40	.CUNA ENGRANAJE DE ANILLO (0.4	1		UR
	1J7-46117-Y0-50	.CUNA ENGRANAJE DE ANILLO (0.5	1		UR
20	93316-01403	.COJINETE	1		
21	22U-46118-00-12	.ARANDELA DE EMPUJE (1.2T)	1		UR
	22U-46118-00-14	.ARANDELA DE EMPUJE (1.4T)	1		UR
	22U-46118-00-16	.ARANDELA DE EMPUJE (1.6T)	1		UR



1TE110-6230

FIG. 23 EJE DE TRACCION

REF. NO.	CODIGO NO.	DESCRIPCION	3LPH			OBSERVACION
21	22U-46118-00-18	.ARANDELA DE EMPUJE (1.8T)	1			UR
	22U-46118-00-20	.ARANDELA DE EMPUJE (2.0T)	1			UR
22	93211-44348	.ANILLO O	1			
23	95311-08600	.TUERCA	6			
24	92901-08700	.ARANDELA	6			
25	95821-10025	.TUERCA DE REBORDE	2			
26	93102-70167	.SELLO ACEITE	1			
27	90340-14109	.TORNILLO, DE DRENAJE	1			
28	214-11198-01	.EMPAQUE	2			
29	56W-17590-00	.RESPIRADERO COMPLETO	1			
30	90340-14042	.TORNILLO, DE DRENAJE	1			
31	4X7-46172-00	EJE DE TRACCION	1			
32	93108-23007	SELLO ACEITE	1			
33	90201-231A2	ARANDELA PLANA	1			
34	93410-23056	BOLA	1			
35	93410-22039	BOLA	1			
36	90501-16491	RESORTE DE COMPRESION	1			
37	4X7-46180-00	JUNTA TRASVERSAL COMPLETA	1			
38	93311-21044	COJINETE	2			
39	93440-20088	BOLA	2			
40	90176-10075	TUERCA CORONA	4			
41	92903-10100	ARANDELA	4			
42	90387-172A5	CASQUILLO CON VALONA	1			

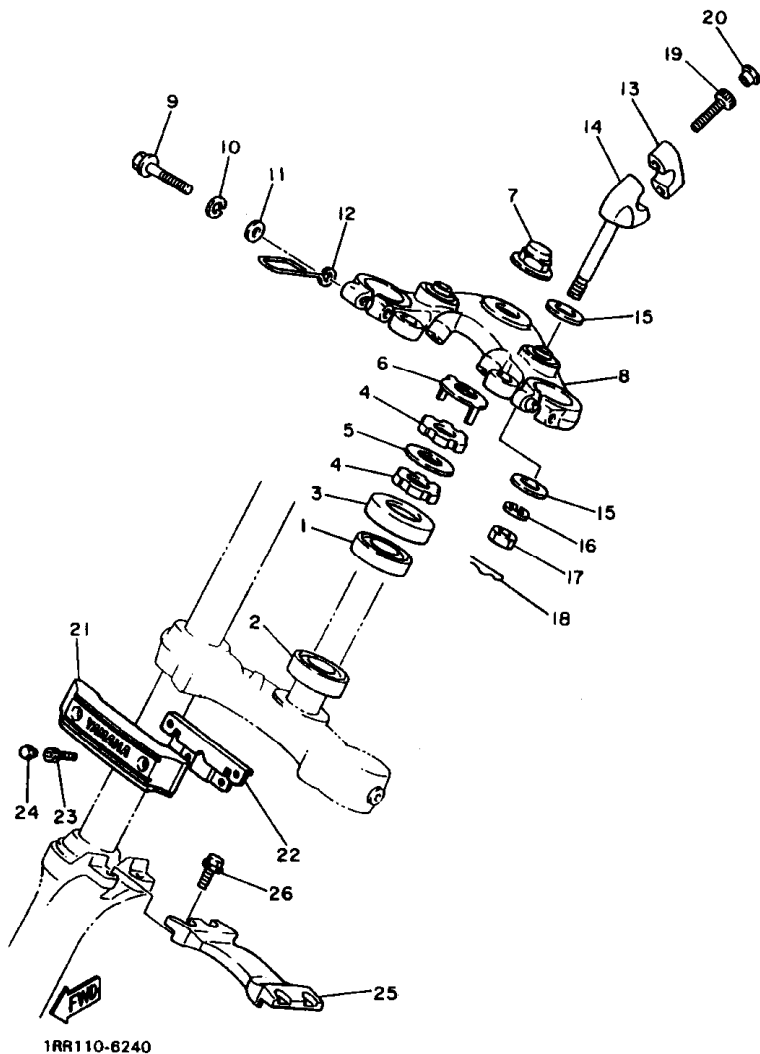

FIG. 24 DIRECCION

REF. NO.	CODIGO NO.	DESCRIPCION	QTY		OBSERVACION
1	93332-00001	COJINETE	1		
2	93332-00008	COJINETE	1		
3	1J7-23415-00	CUBIERTA DE PISTA DE BOLAS 1	1		
4	90179-25033	TUERCA	2		
5	90202-26142	ARANDELA DE PLANA	1		
6	26H-23418-01	ARANDELA ESPECIAL	1		
7	90176-22050	TUERCA CORONA	1		
8	42X-W2341-01-38	FIJADOR DE MANIJA	1		CLP
9	95024-08045	PERNO, DE BRIDA	2		
10	92903-08100	ARANDELA	2		
11	92903-08600	ARANDELA	2		
12	1UF-23317-01	SOSTEN DE CABLE	2		
13	4H7-23441-00-38	SOPORTE DE MANUBRIO	2		CLP
14	42X-23442-00-38	SOPORTE DE MANUBRIO INFERIOR	2		CLP
15	90201-10141	ARANDELA PLANA	4		
16	92901-10100	ARANDELA	2		
17	95301-10700	TUERCA	2		
18	90468-12006	PRESILLA	2		
19	91314-08030	PERNO	4		
20	90338-08163	TAPON	4		
21	1RM-23122-00	CUBIERTA EXTERIOR 1	1		
22	1RM-2317E-00	SOPORTE	1		
23	92014-06012	PERNO	2		
24	90338-08163	TAPON	4		
25	42X-2313A-00	SOPORTE	1		
26	95024-08020	PERNO, DE BRIDA	4		

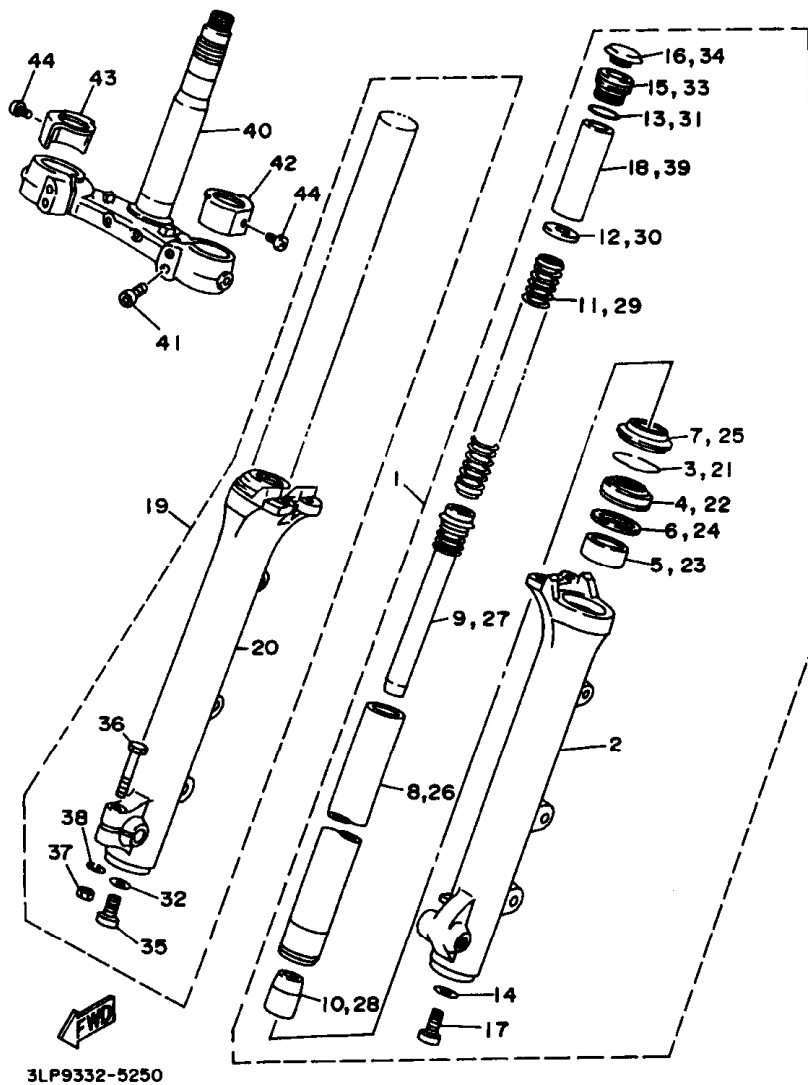

FIG. 25 HORQUILLA DELANTERA

REF. NO.	CODIGO NO.	DESCRIPCION	3LPH				OBSERVACION
1	3LP-23102-33	HORQUILLA DELANTERA COMPL.(MI)	1				
2	3LP-23126-30	.TUBO EXTERIOR 1	1				
3	3R4-23153-00	.ANILLO DE ENGANCHE	1				
4	4DN-23145-00	.RETEN DE ACEITE	1				
5	2YK-23125-00	.METAL CORREDIZO 1	1				
6	4V2-23146-L0	.ARANDELA DE SELLO DE ACEITE	1				
7	4DN-23144-00	.GUARDAPOLVO	1				
8	3JK-23110-12	.TUBO INTERIOR COMPLETO 1	1				
9	42H-23170-00	.CILINDRO COMPL DE HORQ DELAN	1				
10	3JK-23173-12	.VASTAGO AHUSADO	1				
11	42H-23141-00	.RESORTE HORQUILLA DELANT.	1				
12	4FY-23149-00	.ARANDELA DE RESORTE SUPERIOR	1				
13	1W1-23114-L0	.EMPAQUE	1				
14	509-23158-L0	.EMPAQUE	1				
15	3KM-23111-01	.TAPON	1				
16	42H-23168-00	.TAPA DE HORQUILLA DELANTERA	1				
17	278-23181-50	.TORNILLO CABEZAHEXAGONAL	1				
18	42X-23118-00	.SEPARADOR	1				
19	3LP-23103-33	HORQUILLA DELANTERA COMPL.(MD)	1				
20	3LP-23136-30	.TUBO EXTERIOR (DER.)	1				
21	3R4-23153-00	.ANILLO DE ENGANCHE	1				
22	4DN-23145-00	.RETEN DE ACEITE	1				
23	2YK-23125-00	.METAL CORREDIZO 1	1				
24	4V2-23146-L0	.ARANDELA DE SELLO DE ACEITE	1				
25	4DN-23144-00	.GUARDAPOLVO	1				
26	3JK-23110-12	.TUBO INTERIOR COMPLETO 1	1				
27	42H-23170-00	.CILINDRO COMPL DE HORQ DELAN	1				

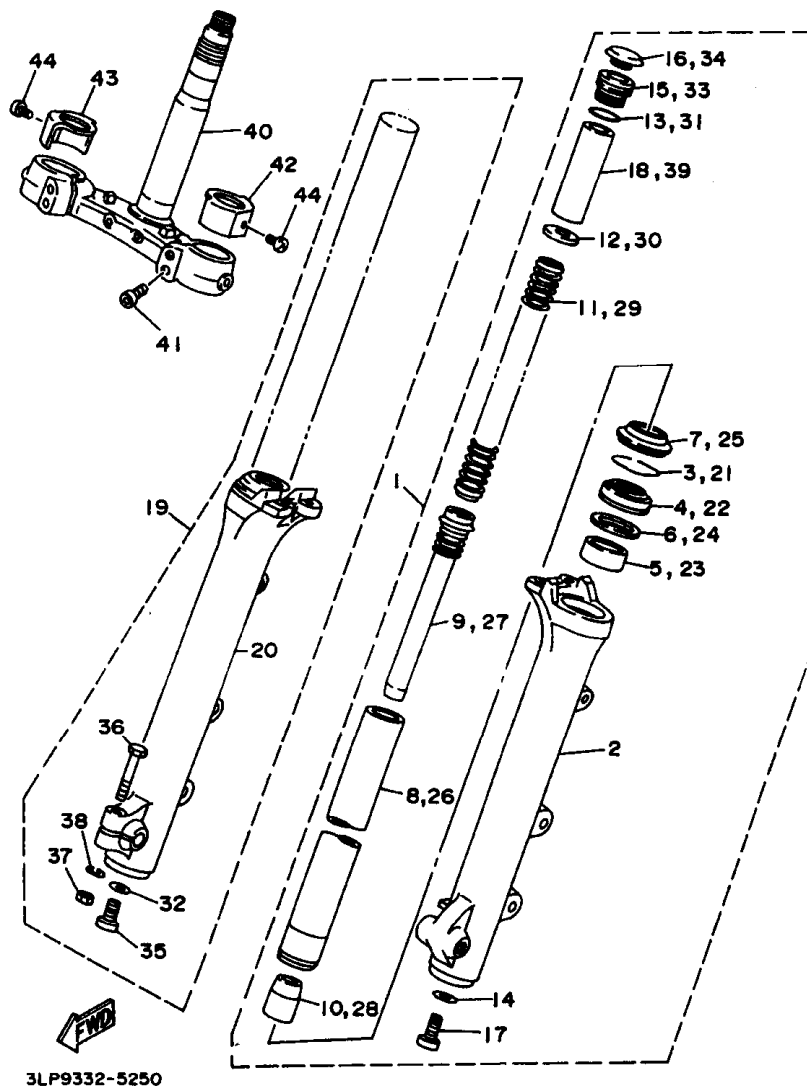
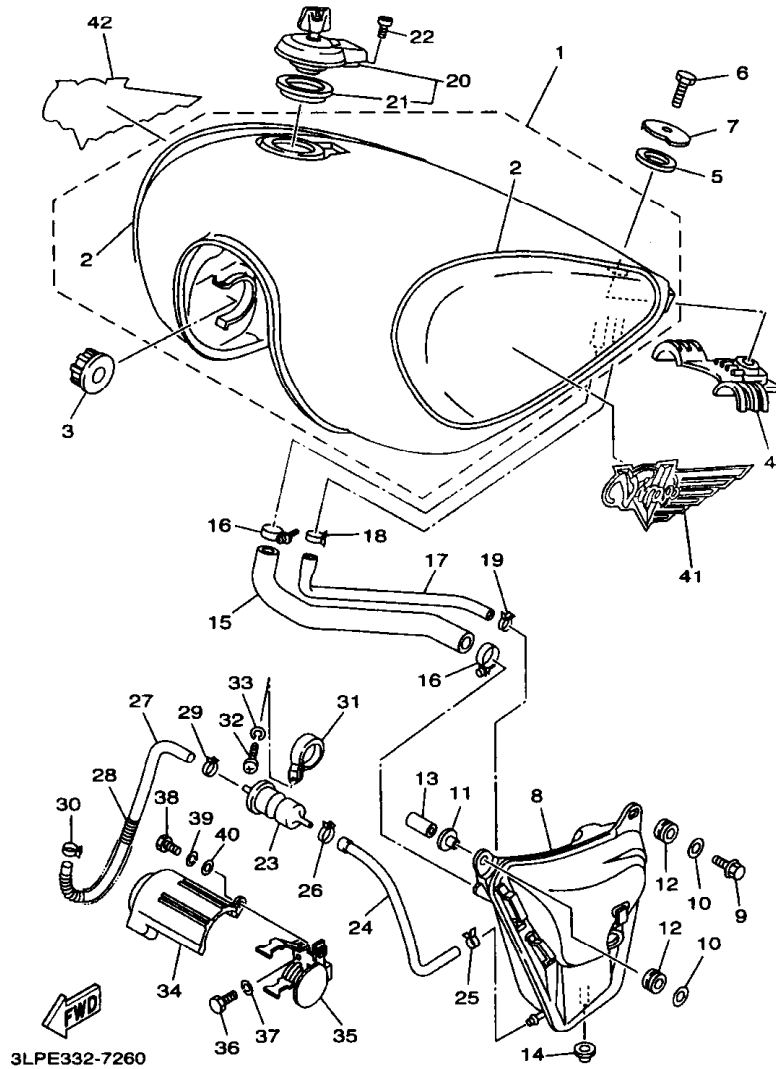

FIG. 25 HORQUILLA DELANTERA

REF. NO.	CODIGO NO.	DESCRIPCION	3LPH				OBSERVACION
28	3JK-23173-12	.VASTAGO AHUSADO	1				
29	42H-23141-00	.RESORTE HORQUILLA DELANT.	1				
30	4FY-23149-00	.ARANDELA DE RESORTE SUPERIOR	1				
31	1W1-23114-L0	.EMPAQUE	1				
32	509-23158-L0	.EMPAQUE	1				
33	3KM-23111-01	.TAPON	1				
34	42H-23168-00	.TAPA DE HORQUILLA DELANTERA	1				
35	278-23181-50	.TORNILLO CABEZAHEXAGONAL	1				
36	4V4-23346-L0	.PERNO 1	1				
37	95311-08600	.TUERCA	1				
38	92901-08100	.ARANDELA	1				
39	42X-23118-00	.SEPARADOR	1				
40	42H-23340-00	PLATINA INFERIOR COMPLETA	1				
41	91311-08030	PERNO	4				
42	1RM-23132-00	CUBIERTA EXTERIOR 2	1				
43	1RM-23132-10	CUBIERTA EXTERIOR 2	1				
44	1RM-23119-00	TAPON DE DRENAJE	2				



3LPE332-7260

FIG. 26 DEPOSITO DE COMBUSTIBLE

REF. NO.	CODIGO NO.	DESCRIPCION	3LPH		OBSERVACION
1	3DR-24110-00-W4	DEPOSITO DE COMBUSTIBLE COMP.	1		UR DNBM1/MRGD
	3DR-24110-00-W5	DEPOSITO DE COMBUSTIBLE COMP.	1		UR MYM/BCR
2	3JL-24240-N0	JUEGO DE CALCOMANIAS	1		UR PARA DNBM1
	3JL-24240-K0	JUEGO DE CALCOMANIAS	1		UR PARA MYM
3	4H7-24181-00	AMORTIGUADOR DE MONTAJE	2		
4	42X-24182-00	AMORTIGUADOR DE MONTAJE 2	1		
5	42X-24183-00	AMORTIGUADOR DE MONTAJE 3	1		
6	97007-08016	PERNO	1		
7	42X-24186-00	ARANDELA ESPECIAL	1		
8	42H-24280-00	SUBDEPOSITO	1		
9	91317-06020	PERNO	1		
10	90201-06557	ARANDELA PLANA	2		
11	90387-062L2	CASQUILLO CON VALONA	1		
12	90480-13163	TAPON	2		
13	90560-06258	SEPARADOR	1		
14	90480-10408	TAPON	1		
15	42H-24316-00	TUBO 6	1		
16	90460-16192	BRIDA, DE UNION	2		
17	42H-24317-00	TUBO 7	1		
18	90467-12053	PRESILLA	1		
19	90467-10135	PRESILLA	1		
20	4X7-24602-04	TAPON COMPLETO	1		
21	4X7-24612-00	EMPAQUE DE TAPA	1		
22	91317-05010	PERNO	1		
23	1FK-24560-00	FILTRO COMPLETO	1		
24	42H-24311-00	TUBO DE COMBUSTIBLE 1	1		
25	90467-10135	PRESILLA	1		

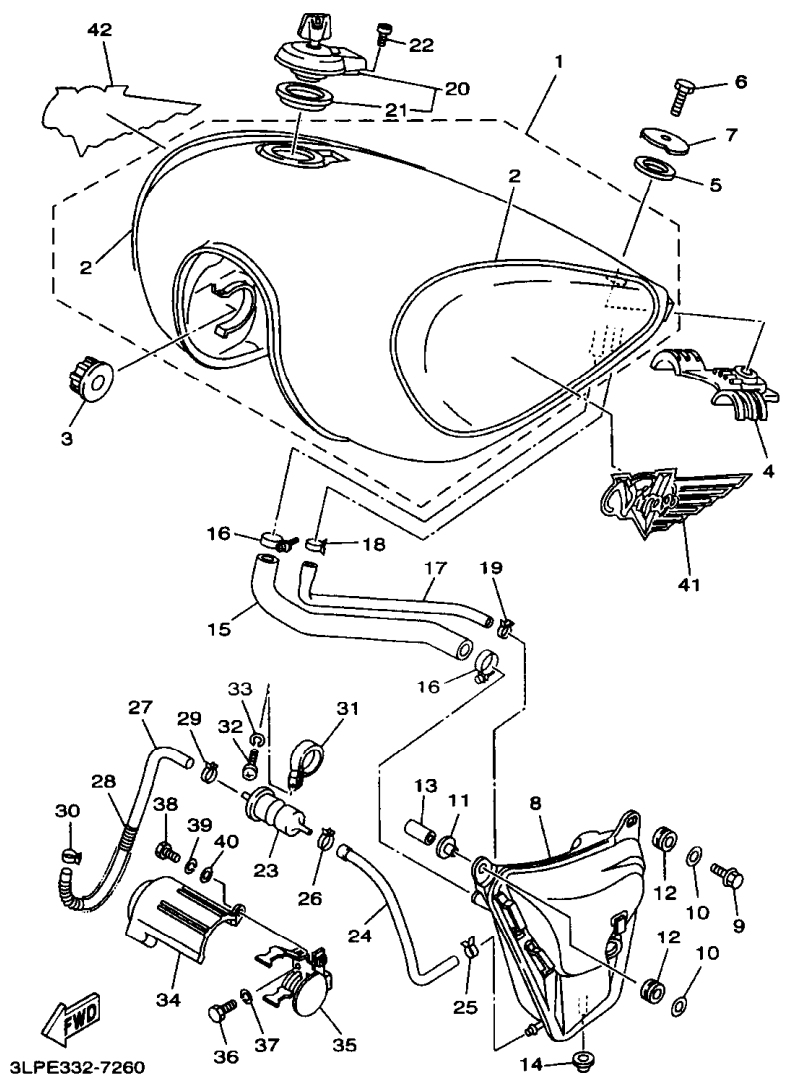

3LPE332-7260

FIG. 26 DEPOSITO DE COMBUSTIBLE

REF. NO.	CODIGO NO.	DESCRIPCION	3LPH				OBSERVACION
26	90467-12053	PRESILLA	1				
27	42H-24315-00	TUBO DE DESAGUE	1				
28	90501-101J5	RESORTE DE COMPRESION	1				
29	90467-12053	PRESILLA	1				
30	90467-10135	PRESILLA	1				
31	90465-08256	BRIDA	1				
32	98507-06010	TORNILLO DE CABEZA CON PLANA	1				
33	92907-06100	ARANDELA	1				
34	42H-24452-00	CUBIERTA	1				
35	3JK-24491-00	SOPORTE BOMBA COMBUSTIBLE	1				
36	97007-06012	PERNO	2				
37	92907-06100	ARANDELA	2				
38	98507-06012	TORNILLO DE CABEZA CON PLANA	1				
39	92907-06100	ARANDELA	1				
40	92907-06600	ARANDELA	1				
41	3LP-24161-10	EMBLEMA 1	1				
42	3LP-24162-10	EMBLEMA 2	1				

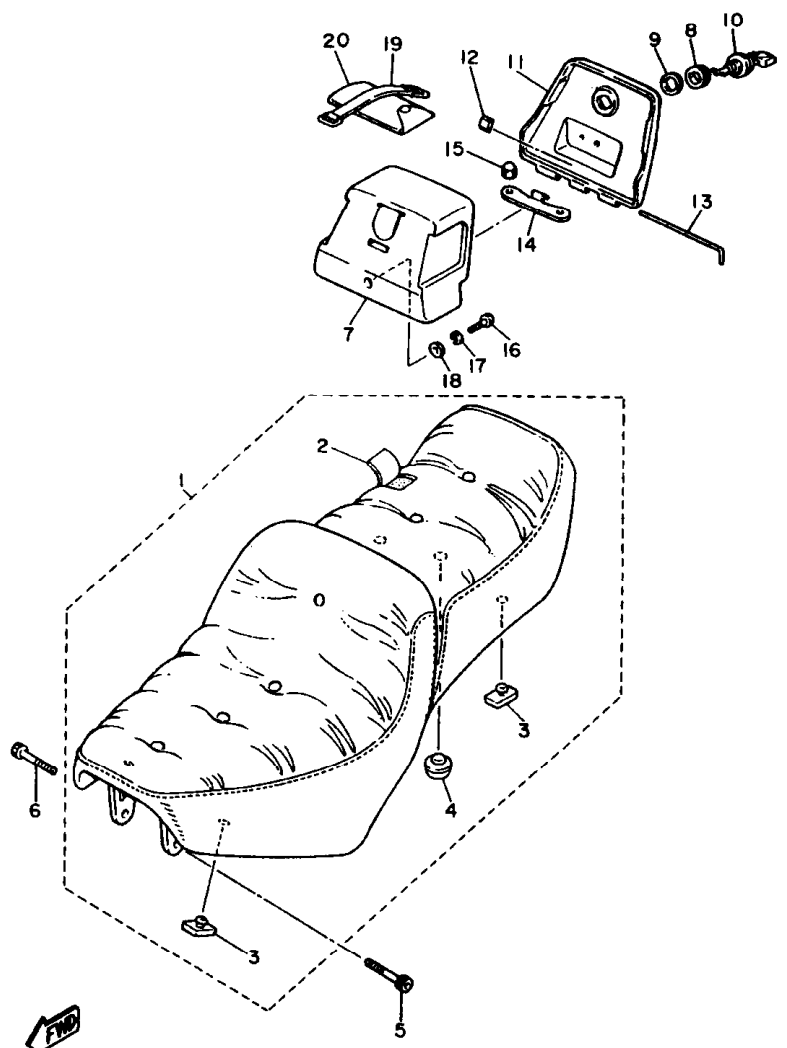

3CF110-8270

FIG. 27 ASIENTO

REF. NO.	CODIGO NO.	DESCRIPCION	3LPH				OBSERVACION
1	3CF-24730-10	SILLIN DOBLE COMPLETO	1				
2	3CF-24731-10	.FUNDA DE SILLIN	1				
3	509-24724-00	.AMORTIGUADOR DE ASIENTO	4				
4	1L9-24741-A0	.COJIN DE ASIENTO	1				
5	91316-06016	PERNO	1				
6	90110-06077	TORNILLO ALLEN	1				
7	42X-2473R-00	CAJA 1	1				
8	90480-24186	TAPON	1				
9	90201-225A4	ARANDELA PLANA (T1.0)	1				
10	5A8-21708-00	CUBIERTA 2	1				
11	42X-2473T-00	TAPA 1	1				
12	3CF-24723-00	AMORTIGUADOR DE ASIENTO	1				
13	42X-2177K-00	PASADOR, DE BISAGRA	1				
14	1RM-2162G-00	PLACA 1	1				
15	90176-06065	TUERCA CORONA	2				
16	97002-06016	PERNO	1				
17	92902-06100	ARANDELA	1				
18	90201-06057	ARANDELA PLANA	1				
19	5H9-21376-00	BANDA DE HERRAMIENTA	1				
20	42X-28100-10	JUEGO DE HERRAMIENTAS	1				

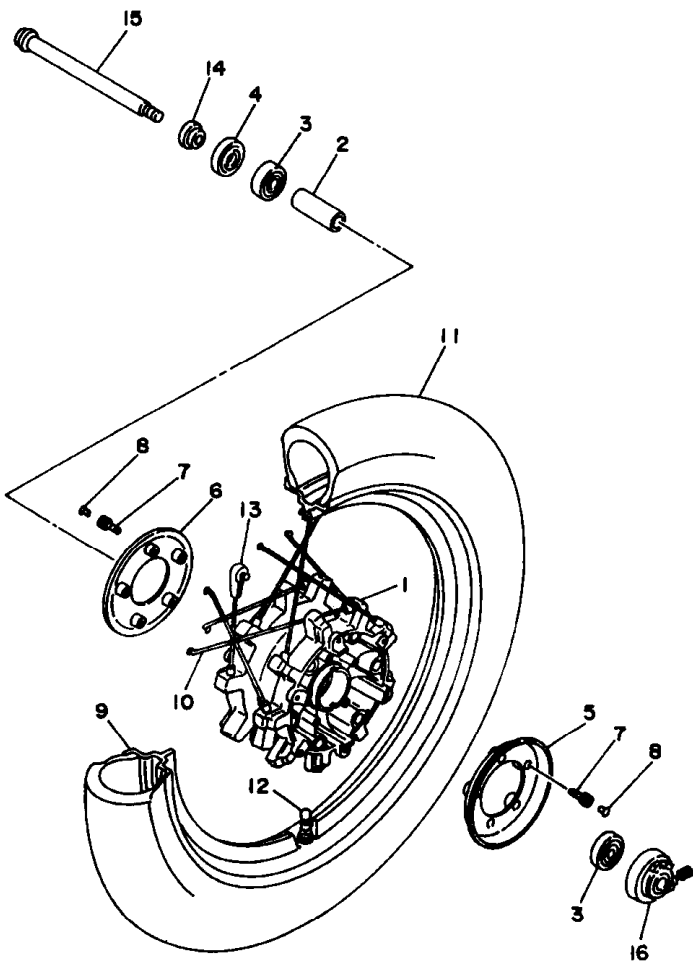

3LP7332-4280

FIG. 28 RUEDA DELANTERA

REF. NO.	CODIGO NO.	DESCRIPCION	3LPH			OBSERVACION
1	3LP-25111-00-35	MASA DELANTERA	1			SL
2	90560-15116	SEPARADOR	1			
3	93306-30202	COJINETE	2			
4	93102-22014	SELLO ACEITE	1			
5	56W-2512A-00	TAPA DE RUEDA (IZQUIERDO)	1			
6	56W-2512A-10	TAPA DE RUEDA (DERECHO)	1			
7	90110-06091	TORNILLO ALLEN	10			
8	90338-06162	TAPON	10			
9	94421-19526	ARO (2.15-19)	1			
10	3LP-25104-00	JUEGO DE RAYOS DELANTERO	1			
11	94110-1904N	NEUMATICO (100/90-19 57H)	1			UR BRIDGESTONE
	94110-1904P	NEUMATICO (100/90-19 57H)	1			UR DUNLOP
12	93900-00022	VALVULA DE ARO	1			TAIHEIYO
13	3LP-25398-00	CONTRAPESO DE RUEDA	1			UN
	3LP-25398-10	CONTRAPESO DE RUEDA	1			UN
	3LP-25398-20	CONTRAPESO DE RUEDA	1			UN
14	90387-15550	CASQUILLO CON VALONA	1			
15	42X-25181-00	EJE DE LA RUEDA	1			
16	42X-25190-00	UNIDAD DE ENGRANAJE COMPLETA	1			

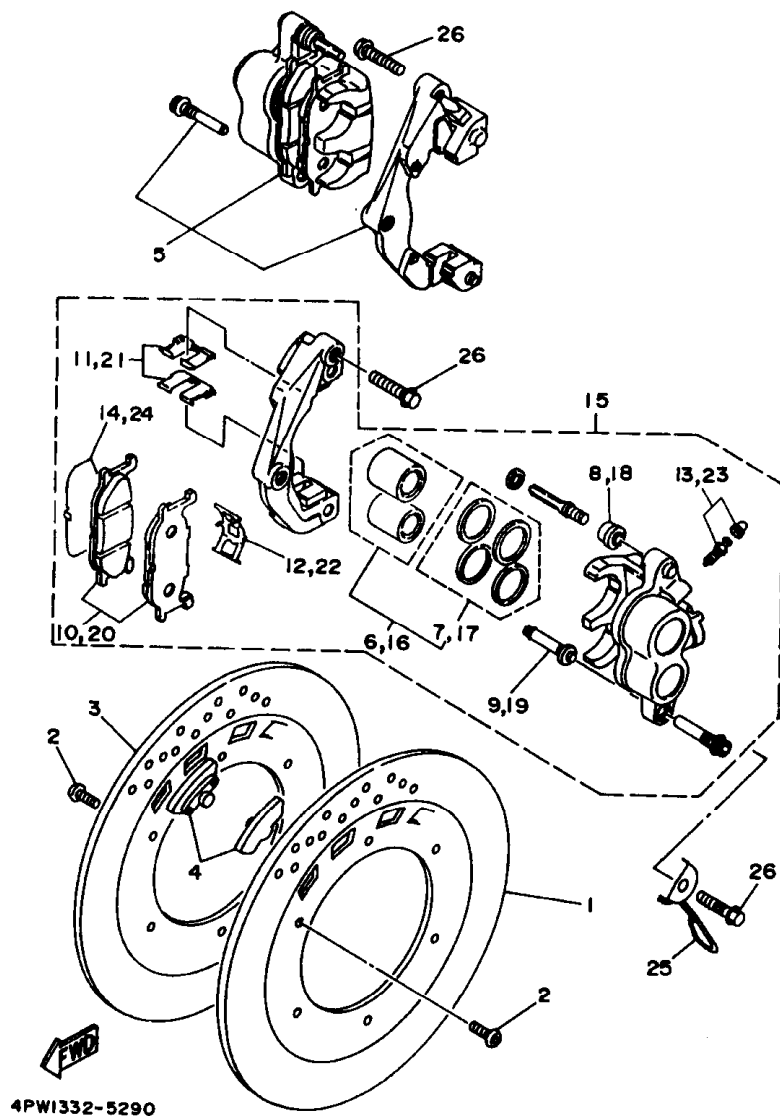
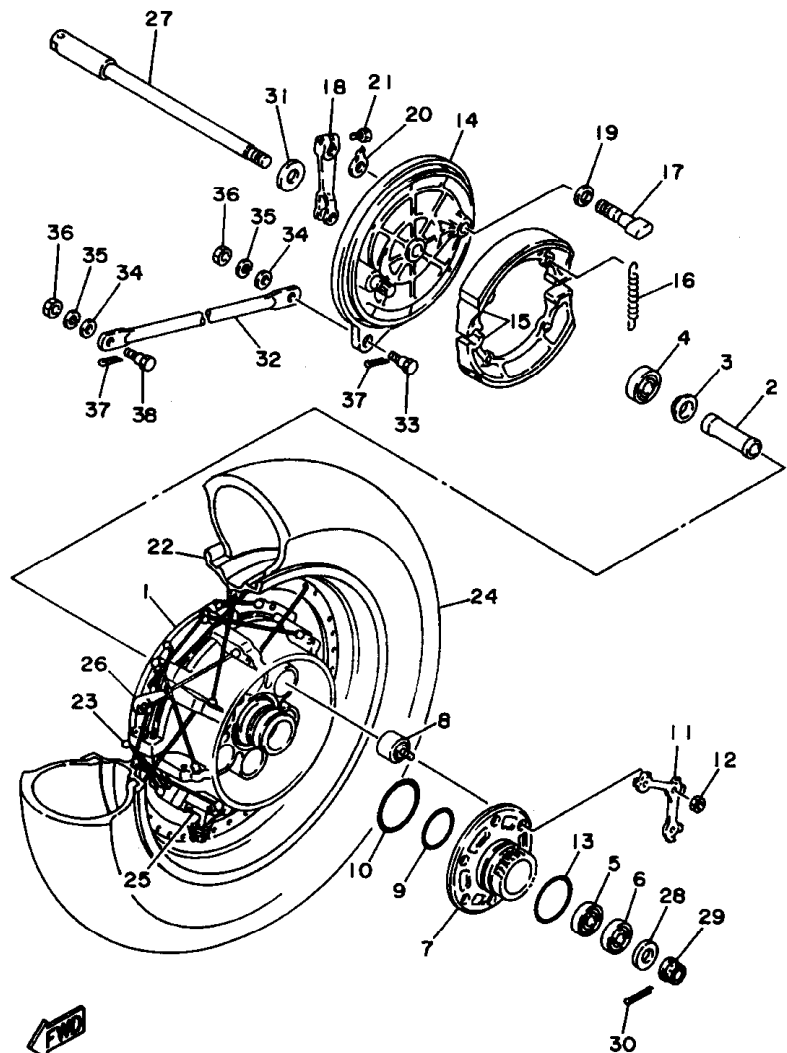

FIG. 29 CALIBRE FRENO DELANTERA

REF. NO.	CODIGO NO.	DESCRIPCION	3LPH				OBSERVACION
1	3LP-2582T-00	DISCO DE FRENO (IZQUIERDO)	1				
2	90109-083G4	PERNO	12				
3	3LP-2582U-00	DISCO DE FRENO (DERECO)	1				
4	3LP-2516A-00	AMORTIGUADOR	12				
5	3LP-2580U-00	CALIBRE COMPLETO (DERECO)	1				
6	3YX-W0057-50	.PISTON COMPLETO PINZA	1				
7	3YX-W0047-50	..JUEGO DE RETENES DE PINZA	1				
8	5R2-25937-00	.FUNDA	1				
9	3YX-25937-00	.FUNDA	1				
10	3LP-W0045-00	.JUEGO DE COJIN DE FRENO	1				
11	3YX-25919-00	.SOPORTE DE PASTILLAS	2				
12	3YX-25929-00	.RESORTE PLACA, COJIN DE FRENO	1				
13	51L-W0048-00	.CJTO TORNILLO DE PURGA	1				
14	4DN-25827-00	.SOPORTE PASTILLA IZQUIERDO	1				
15	3LP-2580T-00	CALIBRE COMPLETO (IZQUIERDO)	1				
16	3YX-W0057-50	.PISTON COMPLETO PINZA	1				
17	3YX-W0047-50	..JUEGO DE RETENES DE PINZA	1				
18	5R2-25937-00	.FUNDA	1				
19	3YX-25937-00	.FUNDA	1				
20	3LP-W0045-00	.JUEGO DE COJIN DE FRENO	1				
21	3YX-25919-00	.SOPORTE DE PASTILLAS	2				
22	3YX-25929-00	.RESORTE PLACA, COJIN DE FRENO	1				
23	51L-W0048-00	.CJTO TORNILLO DE PURGA	1				
24	4DN-25827-00	.SOPORTE PASTILLA IZQUIERDO	1				
25	3LP-23317-00	SOSTEN DE CABLE	1				
26	90105-10638	TORNILLO CON ARANDELA	4				



3LP7351-4300

FIG. 30 RUEDA TRASERA

REF. NO.	CODIGO NO.	DESCRIPCION	3LP		OBSERVACION
1	3LP-25311-00-35	MASA TRASERA	1		SL
2	90560-17249	SEPARADOR	1		
3	148-25315-00	SEPARADOR	1		
4	93306-30306	COJINETE (B6303)	1		
5	93306-20309	COJINETE	1		UR
6	93306-20310	COJINETE (B6203DU)	1		UR
7	16G-25366-01	EMBRAGUE DE MASA	1		
8	42H-25364-00	AMORTIGUADOR	6		
9	93210-48530	ANILLO O	1		
10	93210-59531	ANILLO O	1		
11	16G-25412-00	ARANDELA	2		
12	90170-10219	TUERCA	6		
13	93210-57428	ANILLO O	1		
14	42H-25321-02	PLACA DE ZAPATA DE FRENO	1		
15	3DR-W2536-00	JUEGO DE ZAPATA DE FRENO	1		
16	90507-20002	RESORTE DE TENSION	2		
17	4H7-25351-00	ARBOL DE LEVAS	1		
18	3CF-25355-00	PALANCA DE ARBOL DE LEVAS	1		
19	90201-14577	ARANDELA PLANA	1		
20	4H7-2533A-02	PLACA INDICADOR	1		
21	90101-06764	TORNILLO	1		
22	94430-15525	ARO	1		
23	3LP-25304-00	JUEGO DE RAYOS TRASEROS	1		
24	94114-1504R	NEUMATICO (140/90-15 70H)	1		UR BRIDGESTONE
	94114-1504S	NEUMÁTICO (140/90-15 70H)	1		UR DUNLOP
25	93900-00025	VALVULA DE ARO	1		

FIG. 30 RUEDA TRASERA

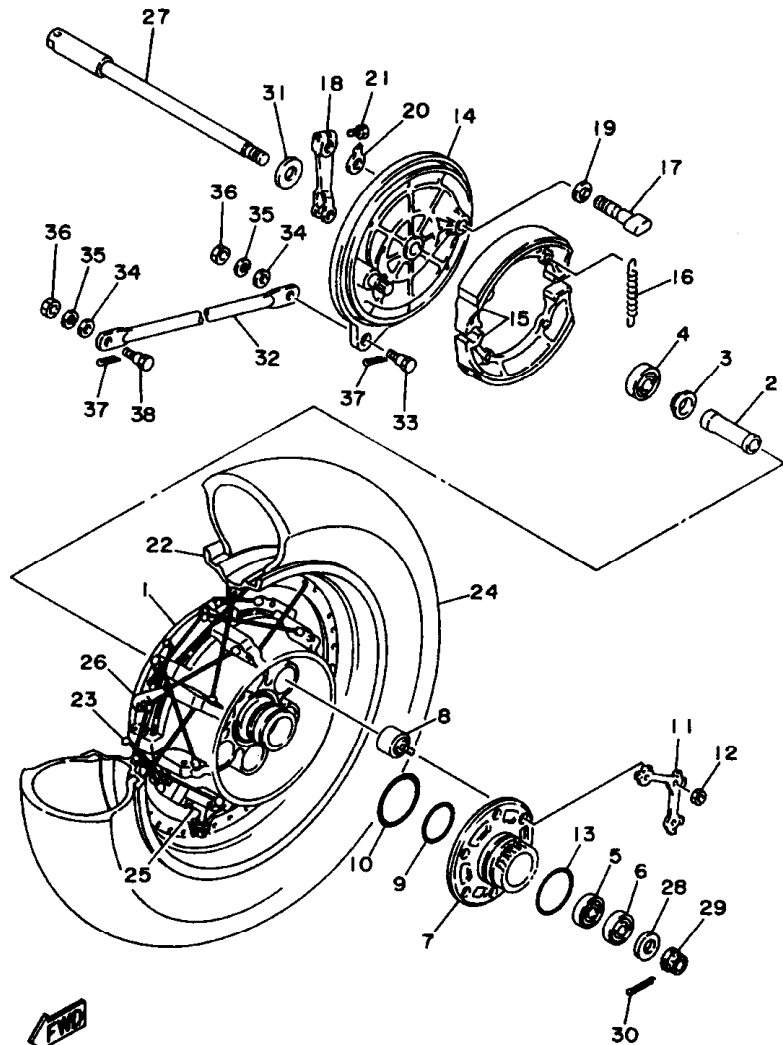

3LP7351 - 4300

REF. NO.	CODIGO NO.	DESCRIPCION	3LPH		OBSERVACION
26	3LP-25398-00	CONTRAPESO DE RUEDA	1		UN
	3LP-25398-10	CONTRAPESO DE RUEDA	1		UN
	3LP-25398-20	CONTRAPESO DE RUEDA	1		UN
27	42X-25381-00	EJE DE RUEDA	1		
28	90201-146R0	ARANDELA PLANA	1		
29	90171-14044	TUERCA ENTALLADA	1		
30	91401-30030	PASADOR DE CHAVETA	1		
31	4H7-25377-00	COLLAR DE RUEDA	1		
32	42X-25371-02	BARRA TENSORA	1		
33	90109-08406	PERNO	1		
34	92903-08600	ARANDELA	2		
35	92903-08100	ARANDELA	2		
36	95304-08700	TUERCA	2		
37	91401-20015	PASADOR DE CHAVETA	2		
38	90109-08368	PERNO	1		

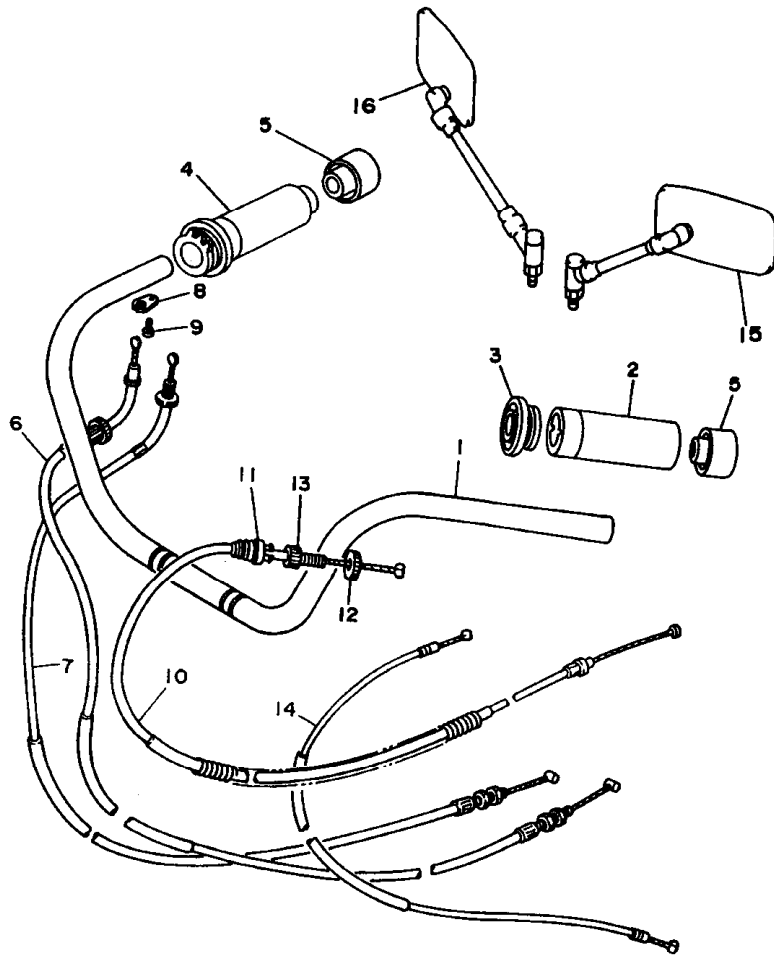

4PW3332-6310

FIG. 31 MANUBRIO. CABLE

REF. NO.	CODIGO NO.	DESCRIPCION	SLPH				OBSERVACION
1	3CF-W2611-10	MANIJA	1				
2	3JB-26241-00	EMPUNADURA (MI)	1				
3	3JB-26273-00	ROTOR	1				
4	3JB-26240-00	EMPUNADURA COMPLETA	1				
5	3JB-2628J-00	TAPA EMPUNADURA	2				
6	3CF-26311-00	CABLE DE ACELERADOR 1	1				
7	3CF-26312-00	CABLE DE ACELERADOR 2	1				
8	5H0-26393-00	SOPORTE	1				
9	98507-05008	TORNILLO DE CABEZA CON PLANA	1				
10	57A-26335-00	CABLE DE EMBRAGUE	1				
11	1E6-26342-00	FUNDA DE CABLE	1				
12	90179-08148	TUERCA	1				
13	90123-08046	PERNO	1				
14	3CF-26331-01	CABLE DE ARRANQUE	1				
15	4H7-26290-A1	ESPEJO COMPLETO (DERECHO)	1				
16	4H7-26290-E1	ESPEJO COMPLETO (DERECHO)	1				

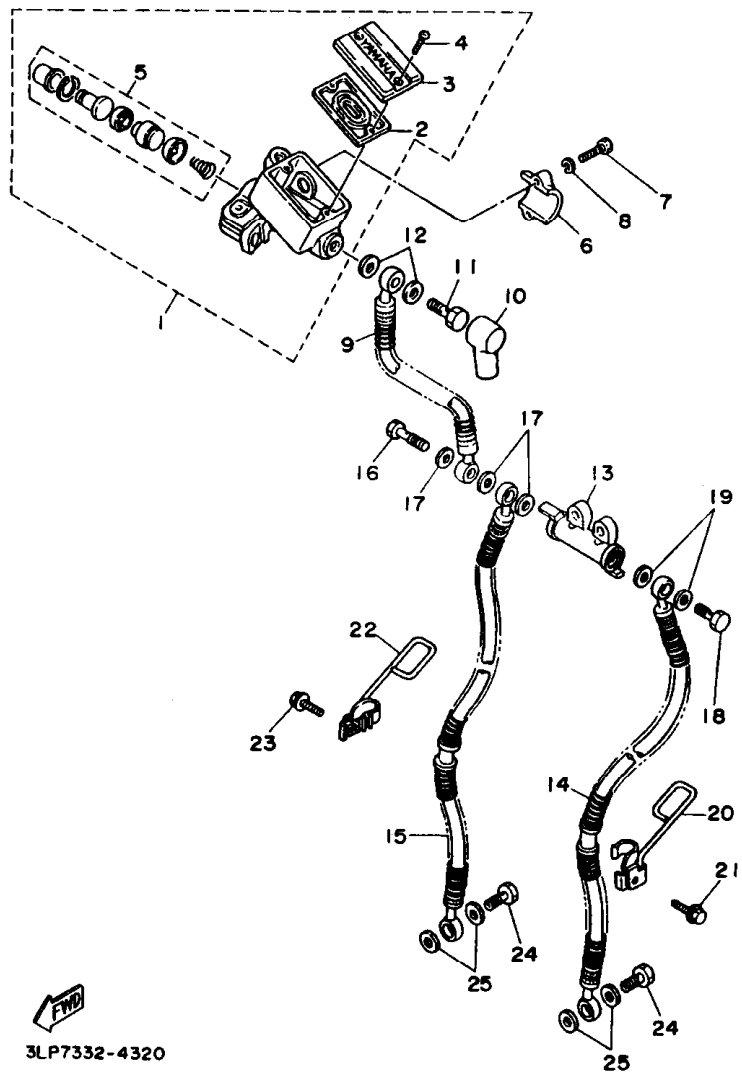

3LP7332-4320

FIG. 32 CILINDRO MAESTRO DELANTERO

REF. NO.	CODIGO NO.	DESCRIPCION	3LP			OBSERVACION
1	22R-25850-02	CILINDRO MAESTRO COMPLETO	1			
2	4K0-25854-00	.DIAFRAGMA TANQUE RESERVA	1			
3	2GV-25852-00	.TAPA DE TANQUE DE RESERVA	1			
4	98706-04012	.TORNILLO DE CABEZA PLANA	2			
5	4K0-W0041-50	.JUEGO DE CILINDRO MAESTRO	1			
6	4L0-25867-00	SOPORTE DE CILINDRO MAESTRO	1			
7	97007-06025	PERNO	2			
8	92907-06600	ARANDELA	2			
9	3LP-25872-12	MANGUERA DE FRENO 1	1			
10	4L0-25862-01	FUNDA DE CILINDRO MAESTRO	1			
11	90401-10159	PERNO DE UNION	1			
12	90201-10118	ARANDELA PLANA	2			
13	42H-25885-01	UNION	1			
14	3LP-25873-11	MANGUERA DE FRENO 2	1			
15	3LP-25874-11	MANGUERA DE FRENO	1			
16	90401-10160	PERNO DE UNION	1			
17	90201-10118	ARANDELA PLANA	3			
18	90401-10159	PERNO DE UNION	1			
19	90201-10118	ARANDELA PLANA	2			
20	55R-25875-00	SOPORTE DE MANGUERA FRENO 1	1			
21	95024-06020	PERNO, DE BRIDA	1			
22	55R-25876-00	SOPORTE DE MANGUERA FRENO 2	1			
23	95024-06020	PERNO, DE BRIDA	1			
24	90401-10159	PERNO DE UNION	2			
25	90201-10118	ARANDELA PLANA	4			

FIG. 33 SOPORTE. APOYAPIE

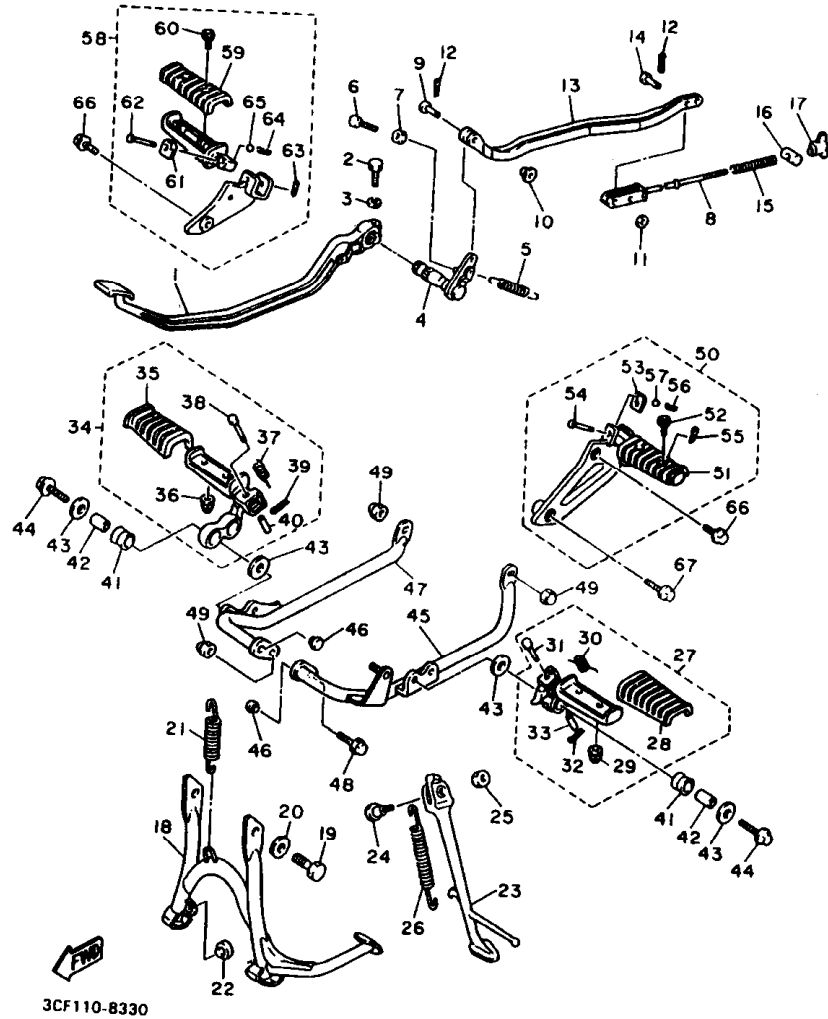

3CF110-8330

REF. NO.	CODIGO NO.	DESCRIPCION	3LPH		OBSERVACION
1	3CF-27211-00-93	PEDAL DE FRENO	1		CM
2	90109-06468	PERNO	1		
3	92903-06100	ARANDELA	1		
4	42X-27212-01	EJE DE PEDAL DE FRENO	1		
5	90506-20192	RESORTE DE TENSION	1		
6	90101-06478	TORNILLO	1		
7	90170-06184	TUERCA	1		
8	3CF-27231-01	VARILLA DE FRENO	1		
9	90240-06057	PASADOR CON HOYO	1		
10	90560-06201	SEPARADOR	1		
11	92901-06200	ARANDELA	2		
12	91401-20012	PASADOR DE CHAVETA	3		
13	3CF-27241-00	UNION DE VARILLA	1		
14	90240-06103	PASADOR CON HOYO	2		
15	90501-10245	RESORTE DE COMPRESION	1		
16	90249-12008	PASADOR	1		
17	90175-06019	TUERCA MARIPOSA	1		
18	42X-27111-00-R4	PUNTAL PRINCIPAL	1		HPB
19	98002-10016	PERNO	2		
20	90201-10141	ARANDELA PLANA	2		
21	90506-35149	RESORTE DE TENSION	1		
22	371-27114-00	TOPE DE PUNTAL PRINCIPAL	1		
23	42X-27311-00-93	PUNTAL LATERAL	1		CM
24	90109-101G3	PERNO	1		
25	95304-10700	TUERCA	1		
26	90507-29009	RESORTE DE TENSION	1		
27	3CF-27410-00-93	APOYAPIE DELANTERO (MI)	1		CM

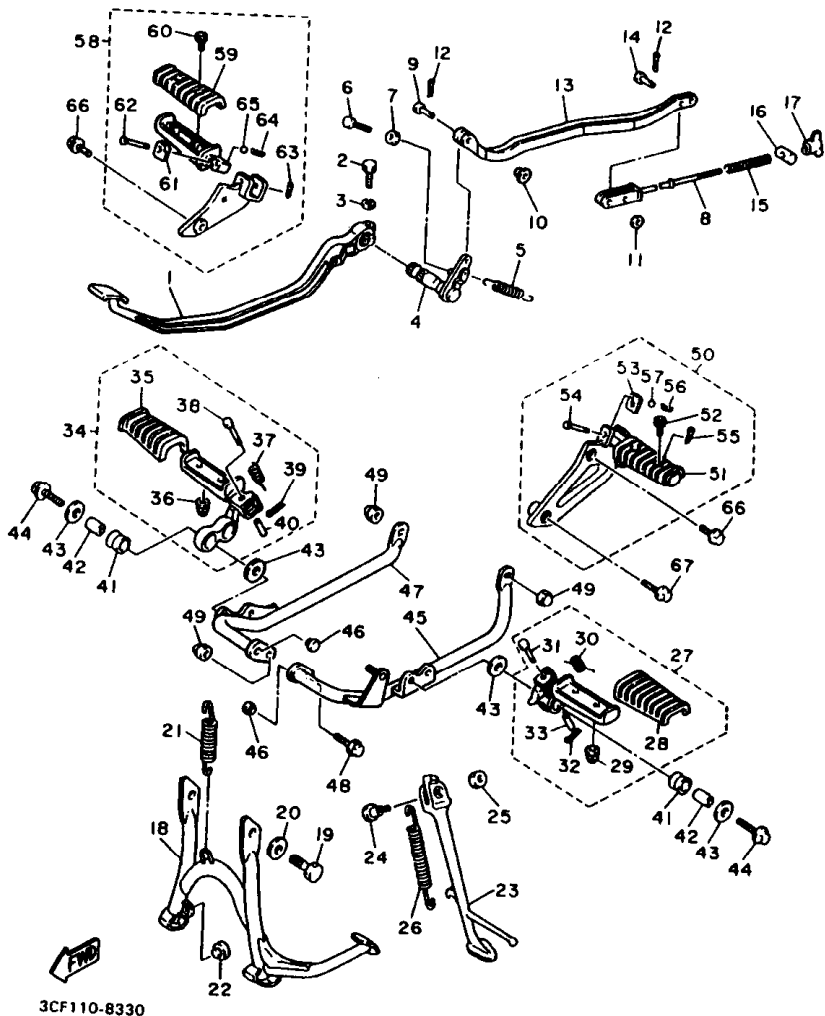
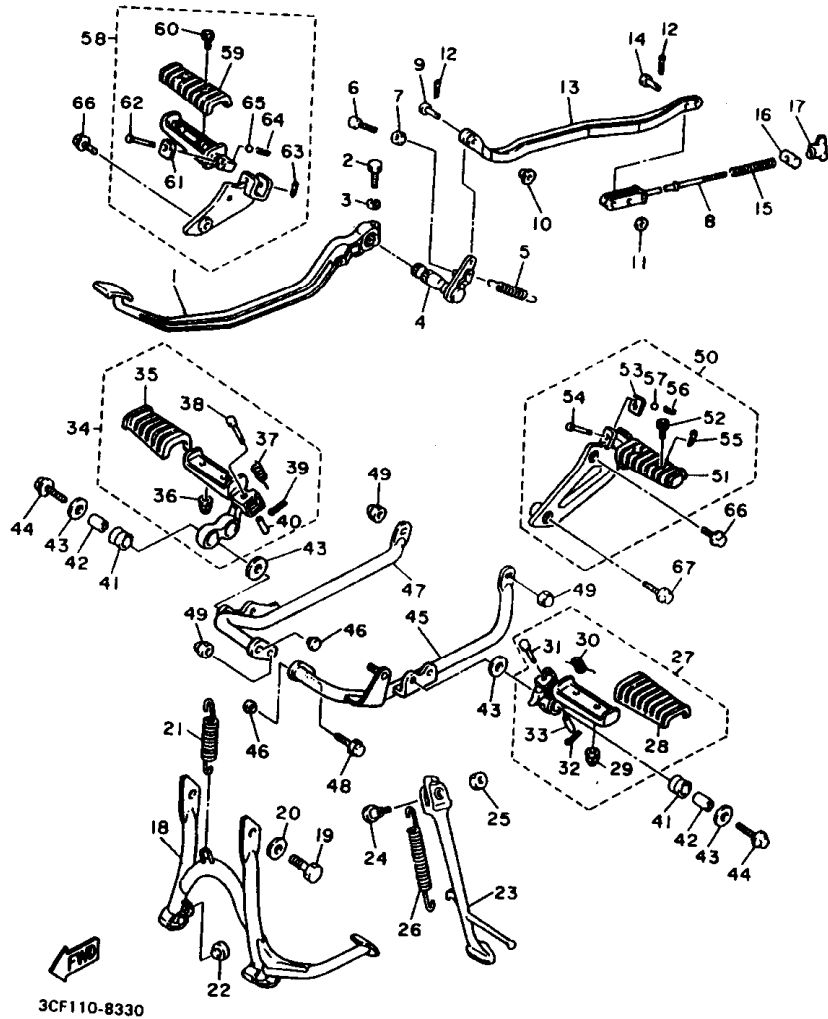

FIG. 33 SOPORTE. APOYAPIE

REF. NO.	CODIGO NO.	DESCRIPCION	H.D.P.			OBSERVACION
28	1NH-27413-00	.CUBIERTA DE APOYAPIE	1			
29	95601-06100	.TUERCA AUTOBLOCANTE	2			
30	90508-18696	.RESORTE DE TORSION	1			
31	90240-08084	.PASADOR CON HOYO	1			
32	91401-25015	.PASADOR DE CHAVETA	1			
33	90387-087K5	.CASQUILLO CON VALONA	1			
34	1RM-27420-00-93	APOYAPIE DELANTERO (MD)	1			CM
35	1NH-27413-00	.CUBIERTA DE APOYAPIE	1			
36	95607-06100	.TUERCA AUTOBLOCANTE	2			
37	90508-18696	.RESORTE DE TORSION	1			
38	90240-08084	.PASADOR CON HOYO	1			
39	91401-25015	.PASADOR DE CHAVETA	1			
40	90387-087K5	.CASQUILLO CON VALONA	1			
41	4X7-27414-00	AMORTIGUADOR DE APOYAPIE	4			
42	90387-107A7	CASQUILLO CON VALONA	4			
43	90201-100A1	ARANDELA PLANA	8			
44	90109-100G0	PERNO	4			
45	3CF-27471-02	BARRA, DE APOYAPIE 1	1			
46	90338-09161	TAPON	2			
47	3CF-27472-02	BARRA, DE APOYAPIE 2	1			
48	90105-10050	TORNILLO CON ARANDELA	1			
49	90178-10075	TUERCA CORONA	3			
50	1RM-27430-02	APOYAPIE POSTERIOR COMPLETO 1	1			
51	1NH-27433-00	.CUBIERTA APOYAPIE TRASERO	1			
52	98516-06012	.TORNILLO DE CABEZA CON PLANA	2			
53	1HX-27437-00	.ARANDELA ESPECIAL	1			
54	91701-06038	.PASADOR DE ABRAZADERA	1			

FIG. 33 SOPORTE. APOYAPIE



REF. NO.	CODIGO NO.	DESCRIPCION	3LPH				OBSERVACION
55	91401-16012	.PASADOR DE CHAVETA	1				
56	90501-12743	.RESORTE DE COMPRESION	1				
57	93501-04004	.BOLA	1				
58	1RM-27440-01	APOYAPIE POSTERIOR COMPLETO 2	1				
59	1NH-27433-00	.CUBIERTA APOYAPIE TRASERO	1				
60	98516-06012	.TORNILLO DE CABEZA CON PLANA	2				
61	1HX-27437-00	.ARANDELA ESPECIAL	1				
62	91701-06038	.PASADOR DE ABRAZADERA	1				
63	91401-16012	.PASADOR DE CHAVETA	1				
64	90501-12743	.RESORTE DE COMPRESION	1				
65	93501-04004	.BOLA	1				
66	95024-08020	PERNO, DE BRIDA	3				
67	95024-08045	PERNO, DE BRIDA	1				

FIG. 35 MOTOR DE ARRANQUE

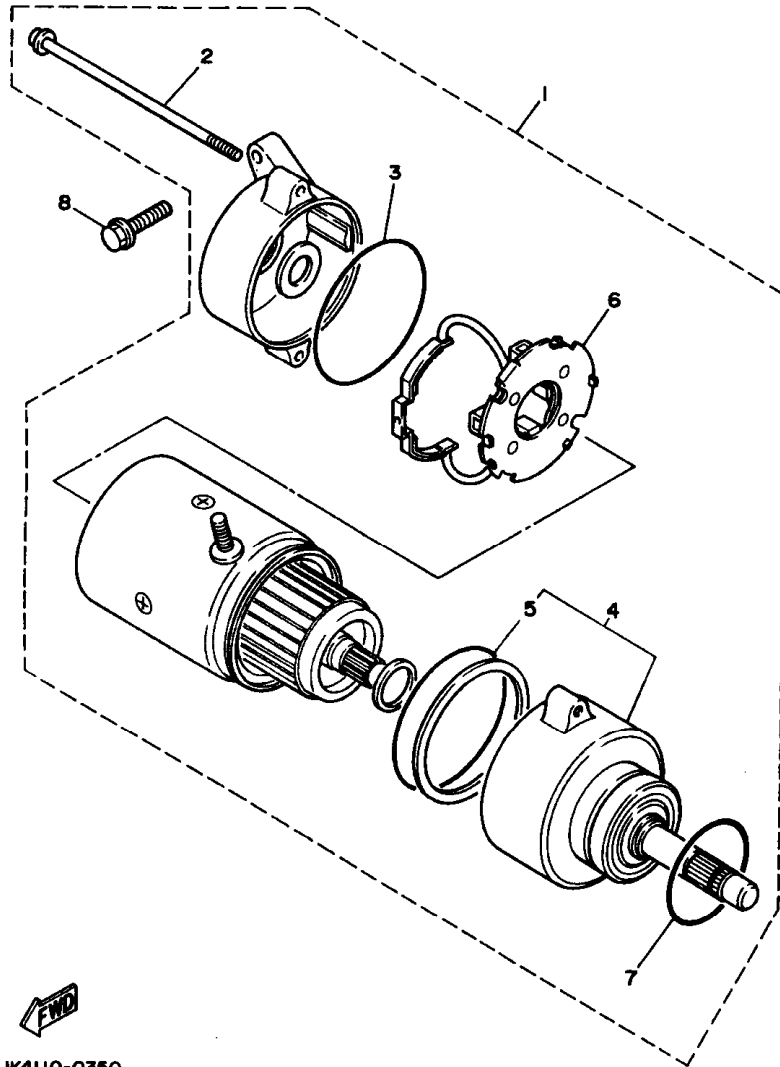

3JK4110-0350

REF. NO.	CODIGO NO.	DESCRIPCION	3LPH			OBSERVACION
1	5A8-81800-10	MOTOR DE ARRANQUE COMPLETO	1			
2	5A8-81826-10	.PERNO	2			
3	11H-81844-00	.EMPAQUE	1			
4	5A8-81830-10	.SOPORTE DELANTERO COMPLETO	1			
5	5A8-81847-10	..ANILLO GOMA	1			
6	5A8-81840-10	.SOSTEN DE ESCOBILLA COMPLETO	1			
7	1J7-81847-60	.ANILLO GOMA	1			
8	95814-06025	TUERCA DE REBORDE	2			

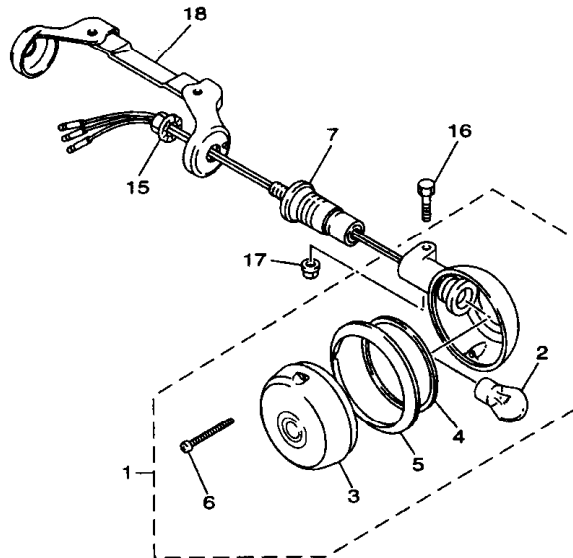
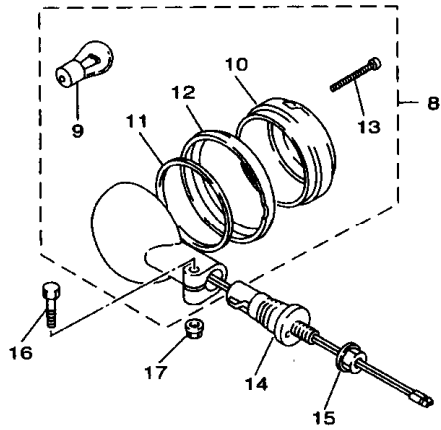

 3LPE332-7360

FIG. 36 LUZ DE DESTELLADOR

REF. NO.	CODIGO NO.	DESCRIPCION	UNID.				OBSERVACION
1	2EN-83310-00	DESTELLADOR DE LUZ DELANT.	2				
2	2AE-83311-00	.BOMBILLA DE DESTELLADOR	1				
3	42X-83312-00	.LENTE DE DESTELLADOR	1				
4	42X-83313-00	.EMPAQUE DE LENTE DESTELLADOR	1				
5	42X-83363-00	.LENTES	1				
6	57M-83358-00	.TORNILLO ESPECIAL	2				
7	1AA-83318-00	SOPORTE DE DESTELLADOR 1	2				
8	2EN-83330-00	DESTELLADOR DE LUZ TRAS.COMPL.	2				
9	2AE-83311-00	.BOMBILLA DE DESTELLADOR	1				
10	2AE-83312-00	.LENTE DE DESTELLADOR	1				
11	42X-83313-00	.EMPAQUE DE LENTE DESTELLADOR	1				
12	42X-83363-00	.LENTES	1				
13	57M-83358-00	.TORNILLO ESPECIAL	2				
14	1AA-83328-00	SOPORTE DE DESTELLADOR 2	2				
15	95707-12500	TUERCA DE BRIDA	4				
16	95024-06030	PERNO, DE BRIDA	4				
17	95704-06500	TUERCA DE BRIDA	4				
18	42X-83328-00	SOPORTE DE DESTELLADOR 2	1				

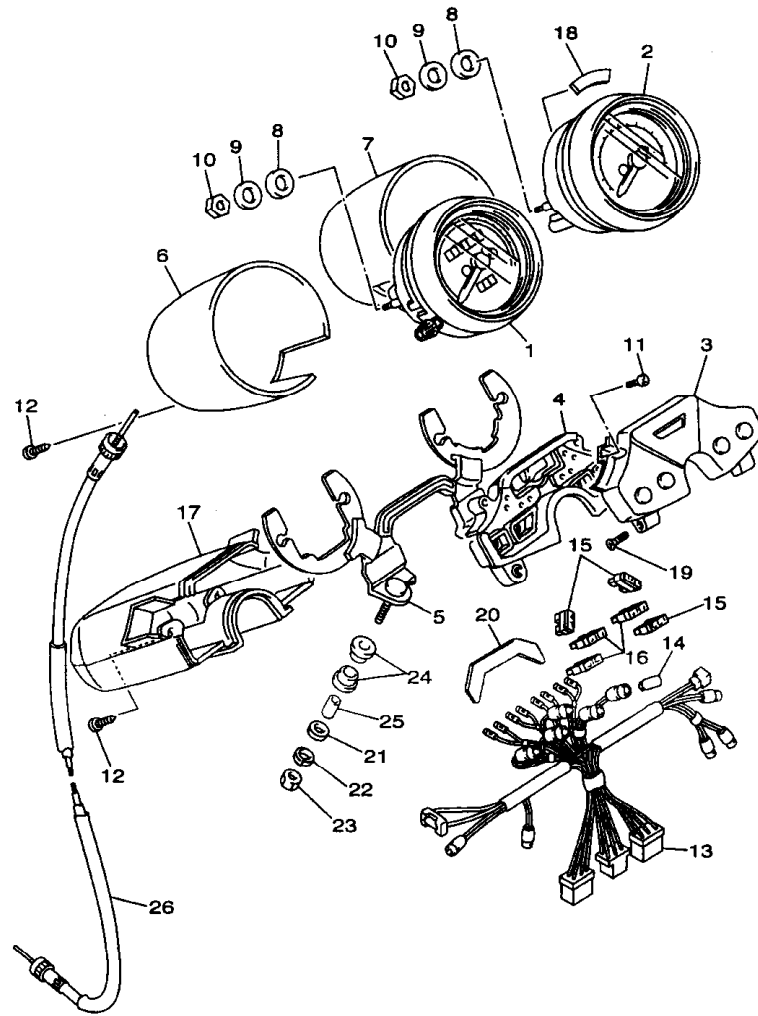

3LPE332-7370

FIG. 37 MEDIDOR

REF. NO.	CODIGO NO.	DESCRIPCION	3LPH			OBSERVACION
1	1RT-83570-F0	VELOCIMETRO COMPLETO	1			
2	1RM-83540-00	TACOMETRO COMPLETO	1			
3	3CF-8353E-01	CAJA DE MEDIDOR SUPERIOR	1			
4	3CF-8353H-00	CAJA INFERIOR	1			
5	1FG-83519-00	SOPORTE DE MEDIDOR	1			
6	42X-83507-00	CUBIERTA DE VELOCIMETRO	1			
7	42X-83508-00	CUBIERTA DE TACOMETRO	1			
8	12R-83523-00	AMORTIGUADOR	4			
9	90201-05725	ARANDELA PLANA	4			
10	95307-05600	TUERCA	4			
11	98507-04008	TORNILLO DE CABEZA CON PLANA	2			
12	97707-40014	TORNILLO ROSCA HEMBRA	6			
13	1RM-83509-00	ENCASTRE DE CABLE COMPLETO	1			
14	42X-83517-00	AMPOLLETA (12V-3W)	10			
15	42X-82151-30	FUSIBLE	3			
16	42X-82151-20	FUSIBLE (10A)	3			
17	42X-83559-00	CUBIERTA DE MEDIDOR	1			
18	1FK-83523-00	AMORTIGUADOR	1			
19	98707-04010	TORNILLO DE CABEZA PLANA	2			
20	55R-83579-00	CUBIERTA DE MEDIDOR 2	1			
21	92907-06200	ARANDELA	2			
22	92907-06100	ARANDELA	2			
23	95307-06600	TUERCA	2			
24	584-83541-00	AMORTIGUADOR	4			
25	90387-06249	CASQUILLO CON VALONA	2			
26	3LP-83550-00	CABLE DE VELOCIMETRO COMPLETO	1			

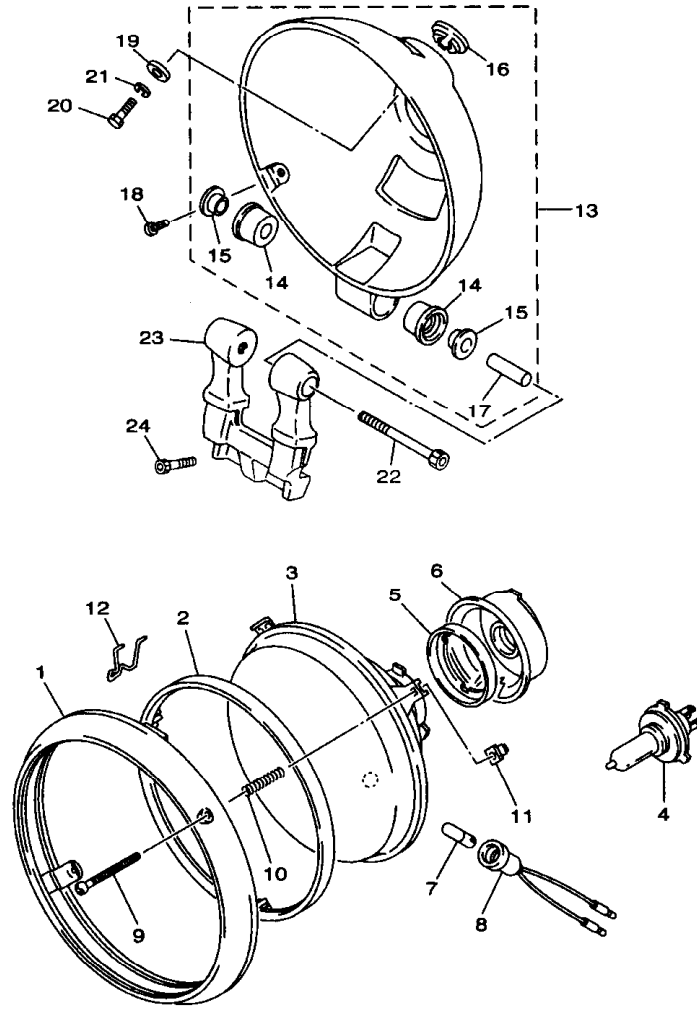

3LPE332-7380

FIG. 38 FARO DELANTERO

REF. NO.	CODIGO NO.	DESCRIPCION	QUPH			OBSERVACION
1	42X-84315-01	ARO DE FARO DELANTERO	1			
2	5Y3-84395-00	ANILLO DE RETEN	1			
3	2AE-84320-G0	LENTE COMPLETO	1			
4	*	BOMBILLA(12V-60/55W)	1			LM HALOGEN
5	2F9-84375-00	PLACA FIXATION DE BOMBILLO	1			
6	2F9-84397-01	CUBIERTA DE ENCASTRE	1			
7	*	BOMBILLA (12V-4W)	1			LM
8	306-84346-30	ENCASTRE DE LUZ PILOTO	1			
9	341-84331-60	TORNILLO DE AJUSTE DE ARO	2			
10	1A0-84332-60	RESORTE DE TORNILLO	2			
11	198-84334-60	TUERCA DE AJUSTE	2			
12	42X-84124-60	JUEGO DE RESORTES	1			
13	2UJ-84330-00	CUERPO COMPLETO	1			
14	42X-84345-00	.AMORT DE FARO DELANTERO	2			
15	1FK-84338-00	.COLLAR ACCESORIO DE CUERPO	2			
16	42X-84366-00	.AMORTIGUADOR FARO DELANTERO	1			
17	2UJ-84338-00	.COLLAR ACCESORIO DE CUERPO	1			
18	90157-05084	TORNILLO CABEZA CONICA PLANA	2			
19	90201-060A3	ARANDELA PLANA	1			
20	97007-06016	PERNO	1			
21	92907-06100	ARANDELA	1			
22	91317-06055	PERNO	1			
23	42X-84318-01	APOYO DE FARO DELANTERO 1	1			
24	91317-06025	PERNO	2			

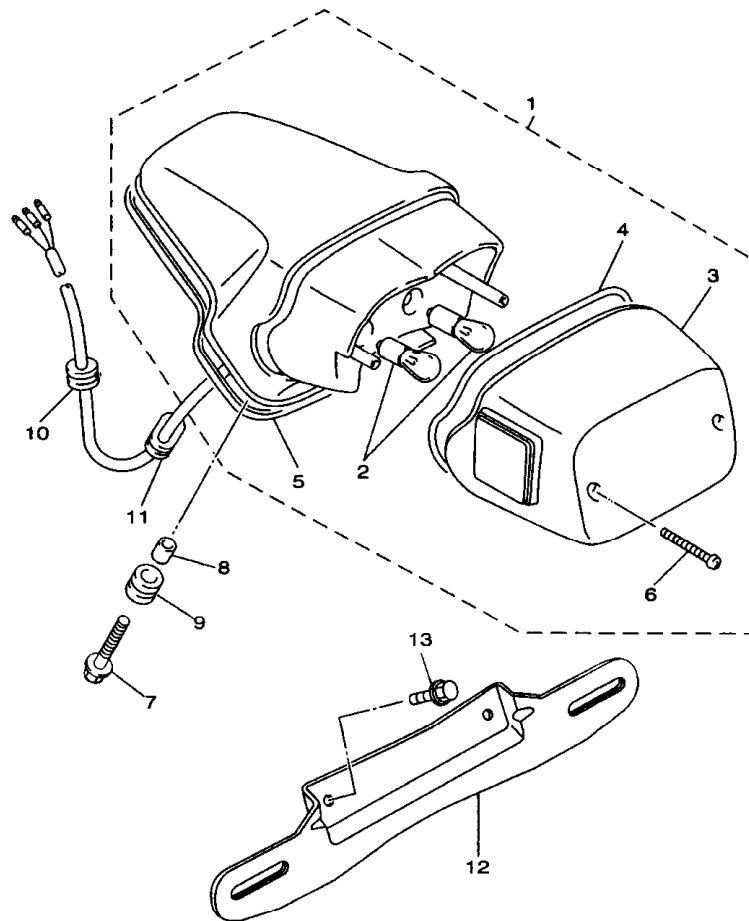

 3LPE351-7390

FIG. 39 LUZ DE COLA

REF. NO.	CODIGO NO.	DESCRIPCION	3LPH				OBSERVACION
1	2EM-84700-E0	FARO TRASERO COMPLET.	1				
2	1A2-84714-41	.AMPOLLETA (12V-21/5W)	1				
3	2AE-84721-00	.LENTE DE FARO TRASERO	1				
4	42X-84723-01	.EMPAQUE LENTE FARO TRASERO	1				
5	1RM-84704-00	.EMPAQUETADURA DE LUZ DE COLA	1				
6	97707-40625	.TORNILLO ROSCA HEMBRA	2				
7	90119-06097	TORNILLO CON ARANDELA	3				
8	90387-065L5	CASQUILLO CON VALONA	3				
9	90480-15316	TAPON	3				
10	90480-16501	TAPON	1				
11	90480-01502	TAPON	1				
12	2YL-84751-00	SOPORTE DE LICENCIA	1				
13	95807-06012	TUERCA DE REBORDE	2				

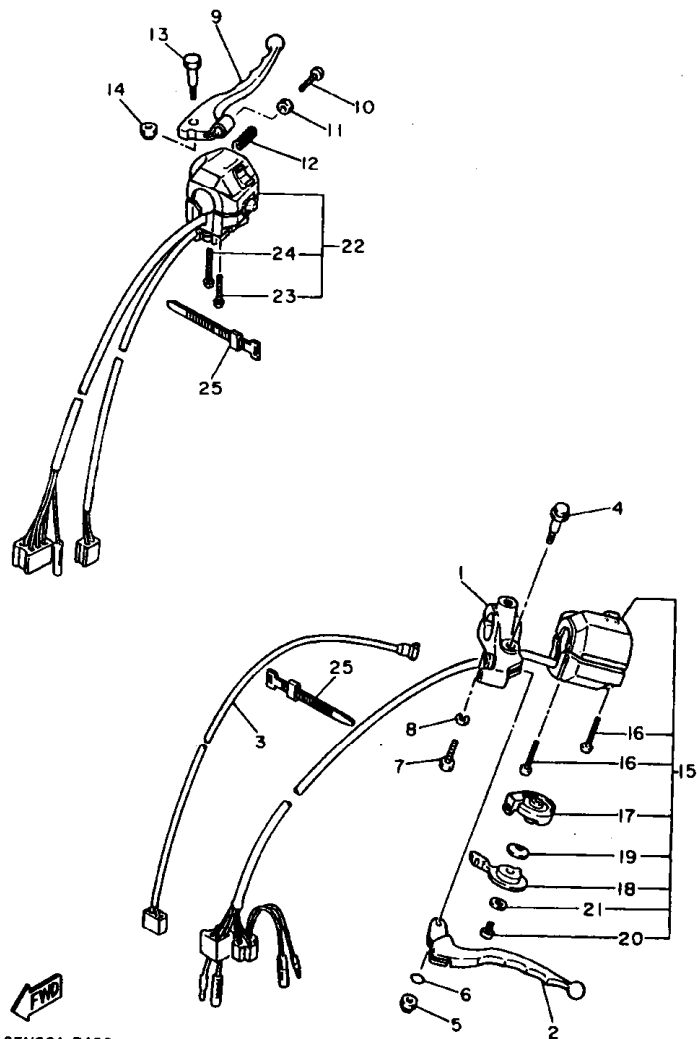

2TN361-7400

FIG. 40 INTERRUPTOR DE MANIJA. PALANCA

REF. NO.	CODIGO NO.	DESCRIPCION	SUPH			OBSERVACION
1	42X-82911-00	SOPORTE DE LEVA 1	1			
2	2GV-83912-00	PALANCA 1	1			
3	2GV-82917-00	INTERRUPTOR	1			
4	90109-06799	PERNO	1			
5	95607-06100	TUERCA AUTOBLOCANTE	1			
6	93210-11368	ANILLO O	1			
7	97007-06025	PERNO	1			
8	92907-06100	ARANDELA	1			
9	2W1-83922-00	PALANCA 2	1			
10	90149-06131	TORNILLO DE REGLAJE	1			
11	90170-06010	TUERCA	1			
12	90501-10312	RESORTE DE COMPRESION	1			
13	90109-06577	PERNO	1			
14	95607-06100	TUERCA AUTOBLOCANTE	1			
15	1AT-83972-01	INTERRUPTOR DE MANIJA 4	1			
16	98507-05035	TORNILLO DE CABEZA CON PLANA	2			
17	10M-83942-00	CUBIERTA DE ARRANQUE	1			
18	10M-83941-00	PALANCA DE ARRANQUE	1			
19	90209-10131	ARANDELA DE SEPARACION	1			
20	98507-06008	TORNILLO DE CABEZA CON PLANA	1			
21	92907-06200	ARANDELA	1			
22	3LP-83972-00	INTERRUPTOR DE MANIJA 4	1			
23	98506-05040	TORNILLO DE CABEZA CON PLANA	1			
24	98506-05045	TORNILLO DE CABEZA CON PLANA	1			
25	437-83936-01	BANDA DE CABLE DE INTERRUPTOR	4			

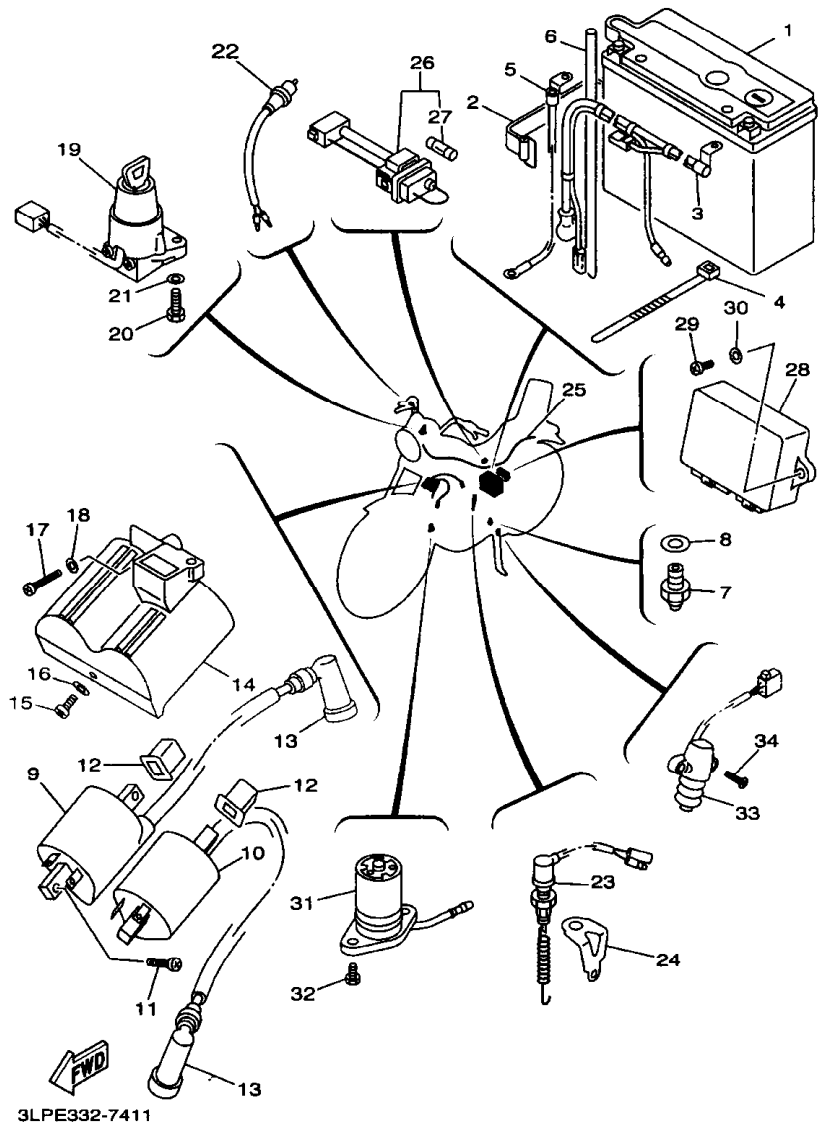

FIG. 41 EQUIPO ELECTRICO 1

REF. NO.	CODIGO NO.	DESCRIPCION	3LPH				OBSERVACION
1	11K-82110-62	BATERIA COMPLETA	1				
2	1E6-82131-00	TIRANTE DE BATERIA	1				
3	42H-82115-00	CABLE CONDUCTOR POSITIVO	1				
4	1UA-82591-00	BANDA	1				
5	42X-82116-00	CABLE CONDUCTOR NEGATIVO	1				
6	90445-081A9	TUBO	1				
7	4KM-82540-00	INTERRUPTOR NEUTRAL COMPL	1				
8	90430-10148	JUNTA	1				
9	42X-82310-70	BOBINA DE ENCENDIDO COMPLETA	1				
10	42X-82320-70	BOBINA DE ENCENDIDO COMPLETA	1				
11	98980-05018	TORNILLO DE LIGAR	2				
12	42X-82317-00	AMORTIGUADOR BOBINA ENCENDIDO	2				
13	1J7-82370-00	TAPON DE BUJIA COMPLT	2				
14	57A-82314-00	CUBIERTA BOBINA ENCENDIDO	1				
15	98507-06012	TORNILLO DE CABEZA CON PLANA	1				
16	92907-06600	ARANDELA	1				
17	98507-06025	TORNILLO DE CABEZA CON PLANA	1				
18	92907-06600	ARANDELA	1				
19	2AE-82501-01	LLAVE DE IGNICION COMPLT	1				
20	97007-06016	PERNO	2				
21	92907-06600	ARANDELA	2				
22	1A0-83980-30	INTERRUP.PARADA DELANTERO	1				
23	42X-82530-02	INTERRUPTOR DE PARADA COMPLETO	1				
24	1FK-82539-00	SOPORTE INTER.DE PARADA	1				
25	3LP-82590-30	CONJUNTO DE CABLES	1				
26	3H5-82150-00	PORTA-FUSIBLES COMPLETO	1				
27	2H7-82151-00	FUSIBLE (12V-30A)	2				

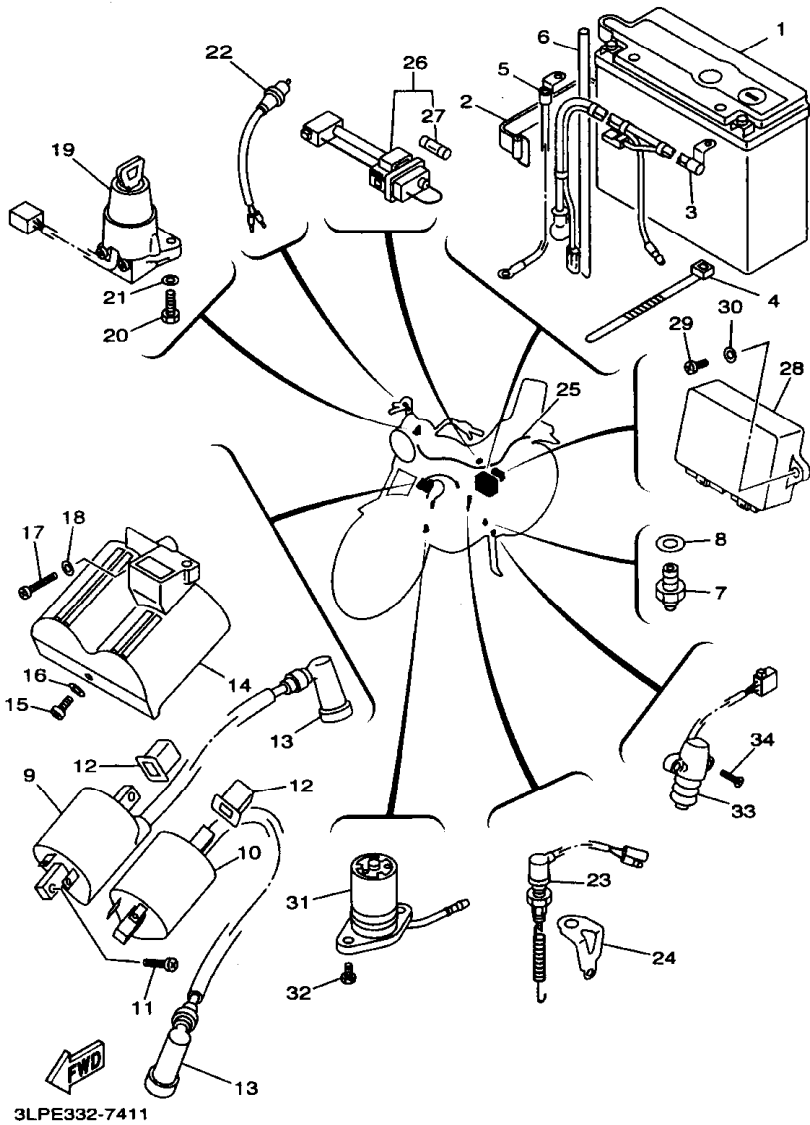
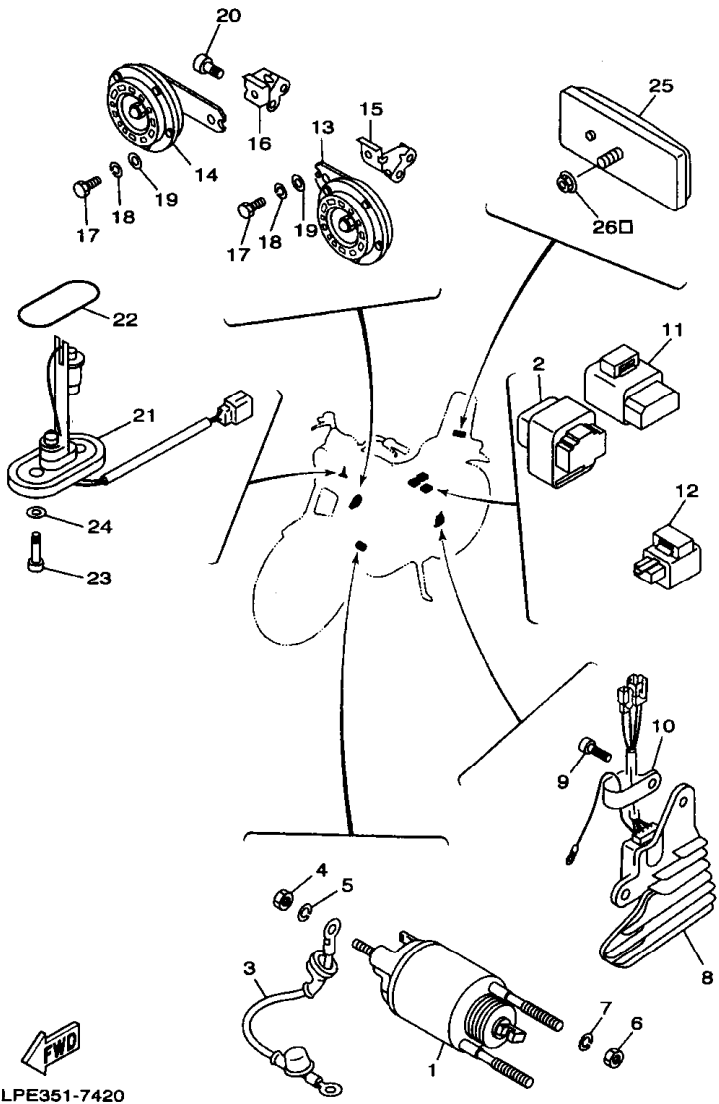

FIG. 41 EQUIPO ELECTRICO 1

REF. NO.	CODIGO NO.	DESCRIPCION	SLPH				OBSERVACION
28	3LP-82305-00	UNIDAD DE ENCENDIDO COMPLETA	1				
29	97707-60520	TORNILLO ROSCA HEMBRA	2				
30	90201-063A5	ARANDELA PLANA	2				
31	3JK-85720-00	MEDIDOR DE NIVEL DE ACEITE	1				
32	91317-06016	PERNO	2				
33	4X7-82566-00	INTERRUPTOR	1				
34	90152-05021	TORNILLO EMBUTIDO	2				



3LPE351-7420

FIG. 42 EQUIPO ELECTRICO 2

REF. NO.	CODIGO NO.	DESCRIPCION	3LPH				OBSERVACION
1	5A8-86110-50	SOLENOIDE	1				
2	25G-81950-01	RELE COMPLETO	1				
3	3JK-81815-00	CABLE, MOTOR DE ARRANQUE	1				
4	95307-08700	TUERCA	1				
5	92907-06100	ARANDELA	1				
6	95307-08700	TUERCA	2				
7	92907-08100	ARANDELA	2				
8	3LP-81960-01	RECTIFICADOR Y REGULADOR	1				
9	97007-06014	PERNO	2				
10	90461-08113	GRAPA	1				
11	3EN-81950-00	RELE COMPLETO	1				
12	3GM-83350-01	RELE DE DESTELLADOR COMPL.	1				
13	2AE-83371-01	BOCINA	1				
14	2AE-83371-11	BOCINA	1				
15	2AE-83378-00	SOPORTE DE BOCINA	1				
16	2AE-83378-10	SOPORTE DE BOCINA	1				
17	97007-08012	PERNO	2				
18	92907-08100	ARANDELA	2				
19	92907-08600	ARANDELA	2				
20	91317-06012	PERNO	2				
21	42H-85752-01	UNIDAD TRANSM. MÉD.COMBUST.	1				
22	42X-85753-00	EMPAQUE DE UNIDAD TRANSMISORA	1				
23	90149-06011	TORNILLO DE REGLAJE	2				
24	90202-05193	ARANDELA DE PLANA	2				
25	42X-85130-01	REFLECTOR TRASERO COMPLETO	1				
26	95707-05500	TUERCA DE BRIDA	1				

INDICE NUMERICO

CODIGO NO.	REF. NO.	CODIGO NO.	REF. NO.	CODIGO NO.	REF. NO.	CODIGO NO.	REF. NO.	CODIGO NO.	REF. NO.	CODIGO NO.	REF. NO.
4K0-W0041-50	E-5	5A8-11650-00	B-5	42H-13907-00	B-11	4BD-14766-00	C-2	1TA-16325-00	C-8	4X7-18140-00	C-13
3LP-W0045-00	D-15	4X7-11654-01	B-5	42H-13971-00	B-11	42X-1479H-00	C-2	1TA-16334-00	C-8	2H9-18154-00	C-13
3YX-W0047-50	D-15	4X7-11656-00	B-5	3CF-1410A-00	B-14	3CF-1490H-00	B-14	1TA-16335-00	C-8	4G0-18185-01	C-12
51L-W0048-00	D-15	4X7-11656-10	B-5	3CF-14103-01	B-15	3CN-1490J-00	B-14	4X7-16340-00	C-7	4X7-18511-00	C-12
3YX-W0057-50	D-15	4X7-11656-20	B-5	12R-14105-00	B-14	3CF-1490K-00	B-15	2H7-16341-00	C-7	4X7-18512-00	C-12
3JK-W1542-01	C-5	4X7-11656-30	B-5	3CF-14107-15	B-14	4PP-14900-01	B-14	2H7-16343-00	C-7	4X7-18513-00	C-12
3LP-W1551-00	C-6	4X7-11656-40	B-5	3CF-14141-93	B-14	4PP-14901-01	B-14	1TA-16351-00	C-8	4X7-18531-00	C-12
42X-W2341-01-38	D-8	5G5-11656-00	B-5	4G0-14142-40	B-14	4PP-14902-01	B-14	1TA-16352-00	C-8	4X7-18536-00	C-12
3DR-W2536-00	E-2	5G5-11656-10	B-5	137-14153-00	B-14	3CF-14919-00	B-15	4X7-16356-00	C-7	4X7-18540-01	C-12
3CF-W2611-10	E-4	5G5-11656-20	B-5	2VA-14185-00	B-14	3CF-14933-00	B-14	4X7-16357-00	C-7	136-18542-00	C-12
1TA-Y1757-00	C-10	2J2-12111-01	B-6	537-14186-00	B-14	2JU-14937-00	B-14	1TA-16371-00	C-7	2EM-21110-00-33	C-14
1MY-Y2151-K0-JY	D-2	1TA-12113-00	B-6	12R-14191-00	B-14	3CF-14937-00	B-15	4X7-16383-01	C-7	42X-21164-00	C-3
1MY-Y2151-N0-9B	D-2	1TA-12114-00	B-6	3CF-14197-00	B-15	4PP-14940-00	B-14	4X7-16384-00	C-7	42X-2117F-00	D-4
1RM-Y2161-1X-9B	D-2	4X7-12116-00	B-6	3CG-14197-00	B-11	3CF-14984-01	B-14	4X7-16385-00	C-7	42X-21171-00	D-4
1RM-Y2161-1Y-JY	D-2	4X7-12117-00	B-6			3CG-14987-00	B-11	2H7-16395-01	C-7	4R8-21308-00	D-2
1TF-11102-02	B-2	4X7-12118-00	B-6	4HM-14216-00	B-15	22F-14991-00	B-14	2H7-16396-00	C-7	42X-21315-01	C-14
4X7-1111F-00	B-3	341-12119-02	B-6	620-1423A-75	B-14	4KG-14995-00	B-15	4X7-17121-00	C-9	42X-21316-01	C-14
42X-1111H-01	B-2	5A8-12121-00	B-6	1HX-14231-28	B-14	42H-15100-01	C-3	4X7-17141-00	C-9	42X-21317-00	C-14
1RM-1112E-00	B-3	42X-12151-00	B-6	3G2-14231-12	B-14	2H7-15361-00	C-4	42X-17151-00	C-9	42X-21359-00	C-14
4X7-11127-00	B-2	4X7-12156-01	B-6	4HM-14239-00	B-15	4X7-15361-00	C-4	1TA-17211-00	C-9	5H9-21376-00	D-13
4X7-11133-10	B-2	4X7-12159-00	B-6	3CF-14251-00	B-15	57A-15363-11	C-3	4X7-17221-00	C-9	42X-2139R-00	C-14
42X-11145-00	B-7	42H-12171-00	B-7	1TA-14348-00	B-11	4X7-15388-00	C-5	4X7-17231-00	C-9	4PW-2139U-00	C-15
42X-11152-00	B-2	4X7-12176-00	B-7	1TA-14349-00	B-11	1RM-15411-01	C-4	4X7-17241-00	C-9	4PW-2139U-10	C-15
4X7-11161-00	B-4	42H-12181-00	B-7	3CG-14396-00	B-11	1RM-15415-01	C-4	42X-17251-00	C-9	4PW-2139U-20	C-15
42X-11165-00	B-2	4X7-12210-01	B-7	42X-14401-01	B-11	42X-15417-01	C-4	4X7-17402-00	C-9	4PW-2139X-00	C-15
42X-11166-01	B-2	4DW-12213-00	B-4	10L-14407-00	B-11	1RM-15419-00	C-4	1TA-17411-00	C-9	4PW-2139X-10	C-15
42H-11181-00	B-2			1TA-1441A-00	B-12	3JK-15425-00	C-4	4X7-17524-00	C-10	4PW-2139X-20	C-15
42X-11185-01	B-2	4X7-12215-01	B-4	1TA-1441E-00	B-12	5A8-15429-00	C-4	42X-17526-01	C-10	42X-21458-01	C-14
1L9-11186-00	C-4	4X7-12221-00	B-7	1TA-14422-00	B-12	42X-15441-00	C-5	31A-17527-00	C-10	4X7-21485-00	C-14
42H-11188-01	B-2	4X7-12231-00	B-7	42X-14451-00	B-12	3EG-15451-00	C-4	3H5-17529-00	C-10	3JK-21570-E0	D-2
4X7-11187-01	B-3	4X7-12241-00	B-7	42X-14452-00	B-12	1RM-15455-00	C-4	4X7-17531-00-15	C-10	3JK-21570-F0	D-2
214-11198-01	B-9	4X7-12247-01	B-7	10L-14453-01	B-11	3EG-15459-00	C-4	4X7-17531-00-30	C-10	1RM-2162G-00	D-13
	D-7	1RM-13161-00	C-5	42X-14477-00	B-11	3EG-15462-00	C-5	4X7-17531-00-50	C-10	42X-21629-00	D-2
1TA-11310-00	B-4	4X7-13171-00	B-9	12R-14484-01	B-12	4X7-15484-00	B-9	1J7-17537-Y0-30	D-6	42H-2164A-02	D-2
3EG-11351-01	B-4	10L-13300-00	B-9	42X-14484-00	B-12	4X7-15485-01	B-9	1J7-17537-Y0-40	D-6	1RM-2164F-00	D-2
4X7-11363-01	B-2	10L-13327-00	B-9	42X-14485-00	B-12	4X7-15491-00	C-3	1J7-17537-Y0-50	D-6	1RM-2164G-00	D-2
1TA-11411-00	B-5	4X7-13354-00	B-5	812-14594-00	B-15	1TA-15512-00	C-6	4X7-17551-00	C-10	3JK-2164H-00	D-2
4X7-11534-00	B-7	4X7-13355-00	B-9	1TA-14803-00	B-12	4X7-15521-00	C-6	4X7-17554-00	C-10	3JK-2164J-00	D-2
4X7-11536-00	B-7	4X7-13405-00	B-9	42H-14611-00	C-2	5A8-15542-01	C-6	4X7-17556-00	C-10	3JK-21675-D0	D-2
4X7-11540-02	B-7	1RM-13406-00	B-9	57A-14612-01	C-2	5A8-15550-00	C-6	4X7-17558-00	C-10	3JK-21675-E0	D-2
4X7-11550-01	B-7	4X7-13419-00	C-3	3EG-14613-00	C-2	5A8-15556-00	C-6	4PP-17582-00	C-9	5A8-21708-00	D-13
1TA-11610-00	B-5	4X7-13440-01	B-10	1TA-14621-00	C-2	3EG-15568-00	C-6	4PP-17583-00	C-9	42X-21711-00-JY	D-4
1TA-11610-20	B-5	1RM-13447-00	B-10	42X-14663-02	B-12	3LP-15570-00	C-6	56W-17590-00	D-7	42X-21711-00-9B	D-4
1TA-11610-40	B-5	4G0-13490-01	B-10	42X-1468A-00	C-2	4X7-16111-00	C-7	42X-18110-01	C-13	3LP-21717-00	D-4
1TA-11631-00-A0	B-5	42X-13564-01	B-11	3LP-14711-00	C-2	4X7-16150-02	C-7	42X-18112-01	C-13	42X-2172W-02	D-4
5A8-11633-00	B-5	16G-13569-00	B-11	3EG-14714-00	C-2	3Y1-16154-00	C-7	132-18113-01	C-13	42X-21721-00-JY	D-4
1TA-11636-00	B-5	42X-13578-00	B-11	42X-14748-01	C-2	22U-16321-00	C-8	29L-18115-00	C-13	42X-21721-00-9B	D-4
1TA-11638-00	B-5	24M-13586-01	B-11	3YF-14755-00	C-2	4X7-16324-00	C-7	4X7-18120-01	C-13	42X-2176E-00	D-4

INDICE NUMERICO

CODIGO NO.	REF. NO.	CODIGO NO.	REF. NO.	CODIGO NO.	REF. NO.	CODIGO NO.	REF. NO.	CODIGO NO.	REF. NO.	CODIGO NO.	REF. NO.
42X-2177K-00	D - 13	42H-23340-00	D - 10	42H-25364-00	E - 2	3CF-27231-01	E - 6	3LP-81960-01	F - 4	3CF-8353H-00	E - 12
3LS-21781-00	D - 4	4V4-23346-L0	D - 10	16G-25366-01	E - 2	3CF-27241-00	E - 6	11K-82110-62	F - 2	1RM-83540-00	E - 12
1RM-22110-01-35	D - 5	1J7-23415-00	D - 8	42X-25371-02	E - 3	42X-27311-00-93	E - 6	42H-82115-00	F - 2	584-83541-00	E - 12
1J7-22141-00	D - 5	26H-23418-01	D - 8	4H7-25377-00	E - 3	3CF-27410-00-93	E - 6	42X-82116-00	F - 2	3LP-83550-00	E - 12
42X-22141-00	D - 5	4H7-23441-00-38	D - 8	42X-25381-00	E - 3	1NH-27413-00	E - 7	1E6-82131-00	F - 2	42X-83559-00	E - 12
1J7-22143-00	D - 5	42X-23442-00-38	D - 8	3LP-25398-00	D - 14	4X7-27414-00	E - 7	3H5-82150-00	F - 2	1FT-83570-F0	E - 12
4X7-22189-01	D - 5	3DR-24110-00-W4	D - 11		E - 3	1RM-27420-00-93	E - 7	2H7-82151-00	F - 2	55R-83579-00	E - 12
2H7-2219X-00	D - 5	3DR-24110-00-W5	D - 11	3LP-25398-10	D - 14	1RM-27430-02	E - 7	42X-82151-20	E - 12	2GV-83912-00	E - 15
3JK-22210-10	D - 5	3LP-24161-10	D - 12		E - 3	1NH-27433-00	E - 7	42X-82151-30	E - 12	2W1-83922-00	E - 15
3JK-22220-10	D - 5	3LP-24162-10	D - 12	3LP-25398-20	D - 14		E - 8	3LP-82305-00	F - 3	437-83936-01	E - 15
57A-22243-01	D - 5	4H7-24181-00	D - 11		E - 3	1HX-27437-00	E - 7	42X-82310-70	F - 2	10M-83941-00	E - 15
3LP-23102-33	D - 9	42X-24182-00	D - 11	16G-25412-00	E - 2		E - 8	57A-82314-00	F - 2	1GM-83942-00	E - 15
3LP-23103-33	D - 9	42X-24183-00	D - 11	3LP-2580T-00	D - 15	1RM-27440-01	E - 8	42X-82317-00	F - 2	1AT-83972-01	E - 15
3JK-23110-12	D - 9	42X-24186-00	D - 11	3LP-2580U-00	D - 15	3CF-27471-02	E - 7	42X-82320-70	F - 2	3LP-83972-00	E - 15
3KM-23111-01	D - 10	3JL-24240-K0	D - 11	3LP-2582T-00	D - 15	3CF-27472-02	E - 7	1J7-82370-00	F - 2	1A0-83980-30	F - 2
	D - 9	3JL-24240-N0	D - 11	3LP-2582U-00	D - 15	42X-28100-10	D - 13	2AE-82501-01	F - 2	42X-84124-60	E - 13
	D - 9	42H-24280-00	D - 11	4DN-25927-00	D - 15	42X-28185-00	D - 4	42X-82530-02	F - 2	42X-84315-01	E - 13
1W1-23114-L0	D - 10	42H-24311-00	D - 11	22R-25950-02	E - 5	1TA-2840F-00	D - 3	1FK-82539-00	F - 2	42X-84318-01	E - 13
	D - 9	42H-24315-00	D - 12	2GV-25852-00	E - 5	56W-46101-02	D - 8	4KM-82540-00	F - 2	2AE-84320-G0	E - 12
42X-23118-00	D - 10	42H-24316-00	D - 11	4K0-25854-00	E - 5	1J7-46117-Y0-30	D - 6	4X7-82566-00	F - 3	2UJ-84330-00	E - 13
	D - 9	42H-24317-00	D - 11	4L0-25862-01	E - 5	1J7-46117-Y0-40	D - 6	3LP-82590-30	F - 2	341-84331-60	E - 13
1RM-23119-00	D - 10	42H-24452-00	D - 12	4L0-25867-00	E - 5	1J7-46117-Y0-50	D - 6	1UA-82591-00	F - 2	1A0-84332-60	E - 13
1RM-23122-00	D - 8	3JK-24491-00	D - 12	3LP-25872-12	E - 5	22U-46118-00-12	D - 6	42X-82911-00	E - 15	198-84334-60	E - 13
2YK-23125-00	D - 9	1FK-24560-00	D - 11	3LP-25873-11	E - 5	22U-46118-00-14	D - 6	2GV-82917-00	E - 15	17K-84338-00	E - 13
3LP-23126-30	D - 9	4X7-24602-04	D - 11	3LP-25874-11	E - 5	22U-46118-00-16	D - 6	2EN-83310-00	E - 11	2UJ-84338-00	E - 13
42X-2313A-00	D - 8	4X7-24612-00	D - 11	55R-25875-00	E - 5	22U-46118-00-18	D - 7	2AE-83311-00	E - 11	42X-84345-00	E - 13
1RM-23132-00	D - 10	3CF-24723-00	D - 13	55R-25876-00	E - 5	22U-46118-00-20	D - 7	2AE-83312-00	E - 11	306-84346-30	E - 13
1RM-23132-10	D - 10	509-24724-00	D - 3	42H-25885-01	E - 5	2H7-46122-00	D - 6	42X-83312-00	E - 11	42X-84366-00	E - 13
3LP-23136-30	D - 9	42X-2473R-00	D - 13	3YX-25919-00	D - 15	4H7-46123-00	D - 6	42X-83313-00	E - 11	2F9-84375-00	E - 13
42H-23141-00	D - 10	42X-2473T-00	D - 13	3YX-25929-00	D - 15	4H7-46125-00	D - 6	1AA-83318-00	E - 11	5Y3-84395-00	E - 13
	D - 9	3CF-24730-10	D - 13	3YX-25937-00	D - 15	1J7-46129-Y1	C - 10	1AA-83328-00	E - 11	2F9-84397-01	E - 13
4DN-23144-00	D - 9	3CF-24731-10	D - 13	5R2-25937-00	D - 15	4H7-46152-00	D - 6	42X-83328-00	E - 11	2EM-84700-E0	E - 14
4DN-23145-00	D - 9	1L9-24741-A0	D - 13	3JB-26240-00	E - 4	4H7-46153-00	D - 6	2EN-83330-00	E - 11	1RM-84704-00	E - 14
4V2-23146-L0	D - 9	42H-24786-00	D - 3	3JB-26241-00	E - 4	4X7-46172-00	D - 7	3GM-83350-01	F - 4	1A2-84714-41	E - 14
4FY-23149-00	D - 10	3LP-25104-00	D - 14	3JB-26273-00	E - 4	4X7-46180-00	D - 7	57M-83358-00	E - 11	2AE-84721-00	E - 14
	D - 9	3LP-25111-00-35	D - 14	3JB-2628J-00	E - 4	1TA-81410-20	E - 9	42X-83363-00	E - 11	42X-84723-01	E - 14
3R4-23153-00	D - 9	56W-2512A-00	D - 14	4H7-26290-A1	E - 4	3JK-81450-00	E - 9	2AE-83371-01	F - 4	2YL-84751-00	E - 14
509-23158-L0	D - 10	56W-2512A-10	D - 14	4H7-26290-E1	E - 4	3JK-81670-00	E - 9	2AE-83371-11	F - 4	42X-85130-01	F - 4
	D - 9	3LP-2516A-00	D - 15	3CF-26311-00	E - 4	5A8-81800-10	E - 10	2AE-83378-00	F - 4	3JK-85720-00	F - 3
42H-23168-00	D - 10	42X-25181-00	D - 14	3CF-26312-00	E - 4	3JK-81815-00	F - 4	2AE-83378-10	F - 4	42H-85752-01	F - 4
	D - 9	42X-25190-00	D - 14	3CF-26331-01	E - 4	5A8-81826-10	E - 10	42X-83507-00	E - 12	42X-85753-00	F - 4
1RM-2317E-00	D - 8	3LP-25304-00	E - 2	57A-28335-00	E - 4	5A8-81830-10	E - 10	42X-83508-00	E - 12	4HM-85885-10	B - 15
42H-23170-00	D - 9	3LP-25311-00-35	E - 2	1E6-26342-00	E - 4	5A8-81840-10	E - 10	1RM-83509-00	E - 12	5A8-86110-50	F - 4
3JK-23173-12	D - 10	148-25315-00	E - 2	5H0-26393-00	E - 4	11H-81844-00	E - 10	42X-83517-00	E - 12	90101-06478	E - 6
	D - 9	42H-25321-02	E - 2	42X-27111-00-R4	E - 6	1J7-81847-60	E - 10	1FG-83519-00	E - 12	90101-06576	C - 2
278-23181-50	D - 10	4H7-2533A-02	E - 2	371-27114-00	E - 6	5A8-81847-10	E - 10	1FK-83523-00	E - 12	90101-06764	E - 2
	D - 9	4H7-25351-00	E - 2	3CF-27211-00-93	E - 6	25G-81950-01	F - 4	12R-83523-00	E - 12	90101-10303	B - 7
1UF-23317-01	D - 8	3CF-25355-00	E - 2	42X-27212-01	E - 6	3EN-81950-00	F - 4	3CF-8353E-01	E - 12	90105-06069	C - 14
3LP-23317-00	D - 15										

INDICE NUMERICO

CODIGO NO.	REF. NO.	CODIGO NO.	REF. NO.	CODIGO NO.	REF. NO.	CODIGO NO.	REF. NO.	CODIGO NO.	REF. NO.	CODIGO NO.	REF. NO.
90105-06154	B - 7	90170-08173	B - 8	90201-14632	D - 6	90387-100E2	C - 14	90480-12053	D - 4	91314-06055	C - 4
	B - 9	90170-10219	E - 2	90201-14633	C - 10	90387-107A7	E - 7	90480-13163	D - 11	91314-06065	C - 4
90105-10050	E - 7	90170-20257	C - 8	90201-151A7	C - 7	90387-124F4	C - 13	90480-14074	B - 12	91314-08030	D - 8
90105-10217	D - 2	90170-20274	C - 7	90201-165H4	B - 5	90387-15550	D - 14	90480-15316	E - 14	91314-08050	B - 2
90105-10275	C - 3	90171-14044	E - 3	90201-20276	C - 9	90387-170E5	C - 6	90480-16233	D - 4	91316-06016	D - 13
90105-10297	C - 14	90175-06019	E - 6	90201-225A4	D - 13	90387-172A5	D - 7	90480-16501	E - 14	91317-05010	D - 11
90105-10298	C - 14	90176-06065	D - 13	90201-231A2	D - 7	90387-172E5	C - 6	90480-20302	C - 3	91317-06010	B - 3
90105-10299	C - 14	90176-10073	D - 5	90201-255A6	C - 10	90387-17543	D - 5	90480-20384	D - 4		B - 9
90105-10300	C - 14	90176-10075	B - 2	90201-30297	C - 12	90387-251E1	C - 11	90480-23444	B - 3	91317-06012	B - 12
90105-10638	D - 15		C - 14	90202-05193	C - 14	90401-10102	B - 9	90480-24186	D - 13		F - 4
90106-10052	D - 5		D - 7		F - 4	90401-10159	E - 5	90501-100F8	B - 11	91317-06016	C - 5
90109-06468	E - 6		E - 7	90202-05208	B - 2	90401-10160	E - 5	90501-101J5	D - 12		E - 9
90109-06577	E - 15	90176-22050	D - 8	90202-26142	D - 8	90401-16065	B - 3	90501-10245	E - 6		F - 3
90109-06667	B - 10	90179-08148	E - 4	90209-06205	B - 7	90401-16067	B - 9	90501-10312	E - 15	91317-06020	D - 11
90109-06799	E - 15	90179-08210	C - 2	90209-10131	E - 15	90413-07023	B - 11	90501-12743	E - 8	91317-06025	E - 13
90109-083G4	D - 15	90179-08673	C - 2	90209-22191	C - 9	90430-06014	C - 3	90501-16491	D - 7	91317-06030	B - 12
90109-08368	E - 3	90179-09379	B - 5	90209-27192	C - 9	90430-10148	F - 2	90501-21133	B - 7		C - 3
90109-08406	E - 3	90179-12325	B - 2	90214-20022	C - 7	90430-15169	B - 9	90501-70762	C - 10		E - 9
90109-08592	B - 7	90179-12326	B - 2	90215-20170	C - 8	90430-17168	B - 3	90506-08227	C - 13	91317-06035	B - 13
90109-100G0	E - 7	90179-12657	C - 14	90215-20182	C - 7		B - 9	90506-10069	C - 7		D - 3
90109-101G3	E - 6	90179-14317	C - 10	90215-22238	D - 5	90445-081A9	F - 2	90506-20192	E - 6	91317-06040	B - 9
90110-06077	D - 13	90179-16448	B - 5	90240-06057	E - 6	90460-12256	B - 11	90506-35149	E - 6	91317-06055	C - 3
90110-06091	D - 14	90179-25033	D - 8	90240-06103	E - 6	90460-16192	D - 11	90507-20002	E - 2		E - 13
90110-06093	C - 5	90179-44328	C - 10	90240-08084	E - 7	90460-65169	B - 11	90507-29009	E - 6	91317-06080	C - 3
90116-08104	B - 2	90179-88336	C - 10	90249-12008	E - 6		B - 12	90508-18696	E - 7	91317-06090	B - 12
90116-08360	D - 6	90185-14070	D - 6	90280-05048	B - 5	90461-08113	F - 4	90508-26494	C - 6	91317-08020	D - 5
90116-10249	D - 6	90201-05725	E - 12	90282-07042	C - 7	90462-08076	C - 4	90508-29531	C - 13	91317-10060	C - 3
90116-10344	B - 2	90201-060A3	E - 13	90338-06121	B - 7	90462-08138	C - 14	90508-32535	C - 13	91317-10070	C - 3
90116-10362	D - 6	90201-06057	D - 13	90338-06162	D - 14	90462-10085	C - 5	90560-06201	E - 6	91317-10100	C - 3
90116-12469	B - 2	90201-063A5	F - 3		D - 3	90462-10098	B - 10	90560-06258	D - 11	91380-06030	C - 5
90119-06097	E - 14	90201-06380	D - 4	90338-07043	C - 14	90462-10143	C - 5	90560-15116	D - 14	91401-16012	E - 8
90123-08046	E - 4	90201-06557	D - 11	90338-08163	D - 5	90462-12142	C - 5	90560-17249	E - 2	91401-20012	E - 6
90149-06011	F - 4	90201-06674	E - 9		D - 8	90465-08256	D - 12	91311-08030	D - 10	91401-20015	E - 3
90149-06131	E - 15	90201-100A1	E - 7	90338-09161	E - 7	90465-08309	C - 4	91314-06016	B - 2	91401-25015	E - 7
90149-06154	D - 2	90201-101A4	B - 2	90338-20113	D - 5	90465-10168	C - 3		B - 3	91401-30030	E - 3
90149-08166	C - 6	90201-10118	E - 5	90340-14042	D - 7	90467-10039	B - 11		C - 4	91701-06038	E - 7
90149-08225	D - 2	90201-10141	D - 8	90340-14109	D - 7	90467-10135	B - 11	91314-06020	B - 10		E - 8
90151-06013	C - 6		E - 6	90340-14135	B - 9		D - 11		C - 4	91817-30011	B - 2
90151-06041	C - 12	90201-105H3	C - 14	90380-25125	B - 7		D - 12		B - 2	92014-06012	D - 8
90152-05021	F - 3	90201-105R9	D - 5	90387-062L2	D - 11	90467-12053	D - 11	91314-06025	B - 4	92901-06200	E - 6
90157-05084	E - 13	90201-10591	B - 7	90387-06249	E - 12		D - 12		B - 7	92901-08100	D - 10
90159-06033	D - 4	90201-12166	C - 13	90387-064E8	C - 3	90467-14015	B - 2		C - 5	92901-08700	D - 7
90159-06058	C - 14	90201-125A3	B - 2	90387-065L5	E - 14	90467-14057	B - 11	91314-06030	C - 3	92901-10100	D - 8
90159-06110	D - 4		C - 14	90387-07598	B - 12	90468-05113	B - 9		C - 4	92902-05100	B - 14
90159-06128	D - 2	90201-12588	C - 13	90387-07674	D - 4	90468-12006	D - 8	91314-06040	B - 4	92902-06100	D - 13
90170-06010	E - 15	90201-12688	C - 13	90387-0801M	C - 6	90480-01141	D - 4		C - 4	92903-06100	E - 6
90170-06184	E - 6	90201-14577	E - 2	90387-087A5	B - 4	90480-01502	E - 14		C - 5	92903-08100	D - 8
90170-06228	C - 13	90201-146R0	E - 3	90387-087K5	E - 7	90480-10408	D - 11	91314-06050	B - 10		E - 3

INDICE NUMERICO

CODIGO NO.	REF. NO.	CODIGO NO.	REF. NO.	CODIGO NO.	REF. NO.	CODIGO NO.	REF. NO.	CODIGO NO.	REF. NO.	CODIGO NO.	REF. NO.
92903-08600	D - 8	93210-10096	B - 10	93440-20088	D - 7	95707-05500	F - 4	98507-06010	D - 4		
	E - 3	93210-11368	E - 15	93440-30077	C - 9	95707-06500	C - 6	98507-06012	C - 14		
92903-10100	D - 5	93210-14359	C - 10	93450-24028	B - 5	95707-12500	E - 11		D - 12		
	D - 7	93210-29198	C - 3	93501-04004	E - 8	95807-06012	E - 14		F - 2		
92907-04600	B - 11	93210-32172	C - 4	93604-10011	B - 7	95807-06014	B - 12	98507-06025	F - 2		
92907-05600	B - 12	93210-44545	B - 11	93604-16092	C - 12	95807-06025	B - 12	98507-06030	C - 4		
92907-06100	C - 14	93210-48364	C - 7	93604-20156	C - 12	95814-06025	E - 10	98507-06050	B - 12		
	D - 12	93210-48530	E - 2	93605-10090	B - 7	95817-06016	D - 2	98507-06080	B - 12		
	D - 2	93210-52449	C - 10	93608-07082	C - 7	95821-10025	D - 7	98516-06012	E - 7		
	D - 4	93210-54452	B - 10	93608-50158	C - 13	95827-06016	D - 2		E - 8		
	E - 12	93210-56459	B - 10	93900-00022	D - 14	95827-08030	C - 11	98701-05035	C - 12		
	E - 13	93210-57428	E - 2	93900-00025	E - 2	97002-06016	D - 12	98704-06016	C - 4		
	E - 15	93210-59531	E - 2	94110-1904N	D - 14	97007-06012	D - 13	98706-04008	B - 14		
	F - 4	93210-60426	D - 6	94110-1904P	D - 14	97007-06014	F - 4	98706-04012	E - 5		
92907-06200	B - 12	93210-62446	B - 3	94114-1504R	E - 2	97007-06016	E - 13	98707-04010	E - 12		
	B - 13	93210-71360	C - 10	94114-1504S	E - 2		F - 2	98707-06014	C - 4		
	C - 2	93210-92448	B - 2	94421-19526	D - 14	97007-06020	D - 4	98904-06010	C - 2		
	E - 12	93211-01467	B - 4	94430-15525	E - 2	97007-06025	E - 15	98980-05016	F - 2		
	E - 15	93211-44348	D - 7	94580-25066	B - 9		E - 5	99001-10600	C - 13		
92907-06600	B - 11	93306-20309	E - 2	94590-45098	B - 7	97007-08012	F - 4	99009-12400	C - 13		
	B - 12	93306-20310	E - 2	94701-00218	B - 3	97007-08016	D - 11	99009-13400	C - 6		
	B - 7	93306-20316	E - 2	94701-00220	B - 3	97017-08020	B - 3	99009-20400	C - 9		
	C - 14	93306-20401	C - 9	95024-06020	E - 5	97024-06020	C - 13	99009-25400	C - 9		
	D - 12	93306-20548	C - 10	95024-06030	E - 11	97027-06012	D - 2	99510-08016	B - 9		
	E - 5	93306-20550	C - 9	95024-08020	D - 8	97027-06020	B - 11	99530-10114	C - 4		
	F - 2	93306-20901	C - 10		E - 8	97027-06025	C - 8	99530-10120	C - 5		
92907-08100	B - 15	93306-30202	D - 14	95024-08035	D - 5	97027-08012	D - 2	99530-14016	C - 3		
	D - 2	93306-30306	E - 2	95024-08045	D - 8	97707-40014	E - 12				
	F - 4	93306-30424	C - 9		E - 8	97707-40112	B - 11				
92907-08200	C - 7	93306-30525	C - 9	95027-08045	C - 2	97707-40625	E - 14				
92907-08600	F - 4	93306-30533	D - 6	95301-10700	D - 8	97707-50508	B - 12				
92990-06600	C - 2	93306-30808	B - 5	95304-06700	C - 13		C - 14				
93101-14102	C - 5	93306-90602	C - 12	95304-08700	E - 3	97707-60520	F - 3				
93101-30084	D - 6	93306-91201	C - 9	95304-10700	E - 6	98002-10016	E - 6				
93101-35099	C - 10	93311-21044	D - 7	95307-05600	E - 12	98502-05016	B - 14				
93101-38098	D - 6	93311-43729	D - 6	95307-06800	E - 12	98506-05040	E - 15				
93102-10247	C - 6	93311-44051	C - 10	95307-06700	F - 4	98506-05045	E - 15				
93102-12106	C - 13	93318-01201	C - 9	95307-08700	B - 7	98507-04008	B - 14				
93102-22014	D - 14	93316-01403	D - 6		C - 7		E - 12				
93102-25017	D - 5	93317-22021	C - 10		F - 4	98507-05008	E - 4				
93102-70167	D - 7	93317-41510	D - 6	95311-08600	D - 10	98507-05010	B - 14				
93104-14059	C - 7	93332-00001	D - 8		D - 7	98507-05012	B - 12				
93104-20068	C - 9	93332-00008	D - 8	95601-06100	E - 7		B - 15				
93108-23007	D - 7	93332-00010	D - 5	95607-06100	E - 15	98507-05014	B - 15				
93210-07135	B - 10	93340-21505	C - 7		E - 7	98507-05035	E - 15				
	B - 9	93410-22039	D - 7	95617-10620	C - 3	98507-06008	E - 15				
	C - 3	93410-23056	D - 7	95617-10670	C - 3	98507-06010	C - 4				
	C - 5	93440-14086	B - 2	95704-06500	E - 11		D - 12				