

YAMAHA



**PARTS
CATALOGUE**

XV1100'95 (3LP9) EUROPE

XV1100'95 (3EF6) SWITZERLAND, AUSTRIA

XV1100'95 (3LPA) SPAIN, BRAZIL

153LP-300E1

YAMAHA
GENUINE
Parts & Accessories

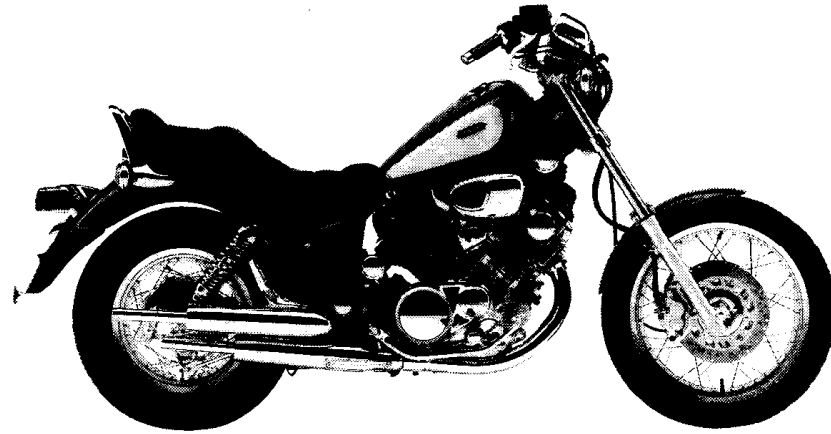

VERY DARK MAGENTA COCKTAIL 1 (0434)



URUSHI BLACK (00JW)

A3

FOREWORD

This Parts Catalogue is related to the parts for the model(s) in the below frame. When you are ordering replacement parts, please refer to this Parts Catalogue and quote both part numbers and part names correctly.

XV1100'95(3LP9/3EF6/3LPA)

1. Modifications or additions which have been made after issue of the Parts Catalogue will be announced in the Yamaha Parts News.
It is advisable that you make necessary corrections to the Parts Catalogue according to the Yamaha Parts News.

2. Abbreviations
The following abbreviations are used in this Parts Catalogue.

"UR" Use specified parts number.
 "UN" Use as many as needed.
 "AP" Alternate Parts
 "LM" Local Made (Parts need to be ordered locally)
 "F#" Frame No. (Applicable machine No.)

3. Parts, which are to be supplied in an assembly, are listed with a dot (.) in front of the part name as shown below.

EXAMPLE
 CARBURETOR ASSY
 . JET, PILOT
 . NOZZLE, MAIN

4. Number of component for assembly
The numeral appearing to the right of each component part indicates the quantity of parts for each assembly unit.

EXAMPLE

PART NO.	DESCRIPTION	Q'TY	REMARKS
2F5-83310-60	FRONT FLASHER LIGHT ASSY	2	
115-83311-60	. BULB (6V-18W)	1	

5. Applicable colors of graphics are represented in the "REMARKS" as shown below.

PART NO.	DESCRIPTION	Q'TY	REMARKS
2N4-24110-00-X5	FUEL TANK COMP.	1	MAXIM RED
3J1-24240-10	. GRAPHIC, FUEL TANK	1	for MXR

6. Applicable Serial No. and Color Code

3LP9	① Frame Serial No.	3LP-036101 ~	
	② Engine Serial No.	3LP-036101 ~	
3EF6	① Frame Serial No.	3EF-006101 ~	
	② Engine Serial No.	3EF-006101 ~	
3LPA	① Frame Serial No.	3LP-047101 ~	
	② Engine Serial No.	3LP-047101 ~	

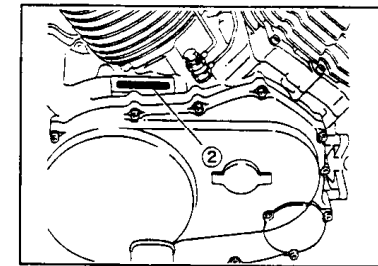
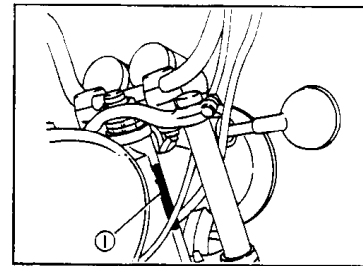

Color Code	Color Name	Abbreviation
0434	VERY DARK MAGENTA COCKTAIL 1	VDMC1
00JW	URUSHI BLACK	URB

7. Note that the illustrations are for reference in finding parts numbers, not to be used for assembling. When assembling, please use the applicable service manual.
8. The asterisk (*) before a reference number indicates modification items after the first edition.

GENERAL SPEC.

CONTENTS

GENERAL SPEC.

ENGINE

Cylinder Head	B2~B3
Cylinder	B4
Crankshaft. Piston	B5~B6
Valve	B7
Camshaft. Chain	B8
Oil Pump	B9
Oil Cleaner	B10
Intake	B11~B13
Carburetor	B14~B15
Exhaust	C2
Crankcase	C3
Crankcase Cover 1	C4~C5
Starter Clutch	C6
Clutch	C7~C8
Transmission	C9
Middle Drive Gear	C10~C11
Shift Cam. Fork	C12
Shift Shaft	C13

CHASSIS

Frame	C14~C15
Fender	D2~D3
Side Cover	D4
Rear Arm. Suspension	D5
Drive Shaft	D6~D7
Steering	D8
Front Fork	D9~D10
Fuel Tank	D11~D12
Seat	D13

Front Wheel	D14
Front Brake Caliper	D15
Rear Wheel	E2~E3
Steering Handle. Cable	E4
Front Master Cylinder	E5
Stand. Footrest	E6~E8
Generator	E9
Starting Motor	E10
Flasher Light	E11
Meter	E12
Headlight	E13
Taillight	E14
Handle Switch. Lever	E15
Electrical 1	F2~F3
Electrical 2	F4

INDEX (GENERAL SPEC.)

Numerical Index	L2~L6
-----------------------	-------

INDIVIDUAL SPEC.

FOR ENGLAND

Alternate (Chassis)	F6
Alternate (Electrical)	F7

FOR BELGIUM ITALY SPAIN BRAZIL

Alternate (Chassis)	F9
Alternate (Electrical)	F10

FOR PORTUGAL GREECE NETHERLAND

Alternate (Chassis)	F12
Alternate (Electrical)	F13

FOR SWITZERLAND AUSTRIA

Alternate (Engine 1)	F15
Alternate (Engine 2)	G2
Alternate (Engine 3)	G3
Alternate (Chassis 1)	G4~G5
Alternate (Chassis 2)	G6
Alternate (Electrical)	G7

FOR NORWAY FINLAND TURKEY

Alternate (Chassis, Electrical) ...	G9
-------------------------------------	----

INDEX (INDIVIDUAL SPEC.)

Numerical Index	M2
-----------------------	----

FIG. 1 CYLINDER HEAD

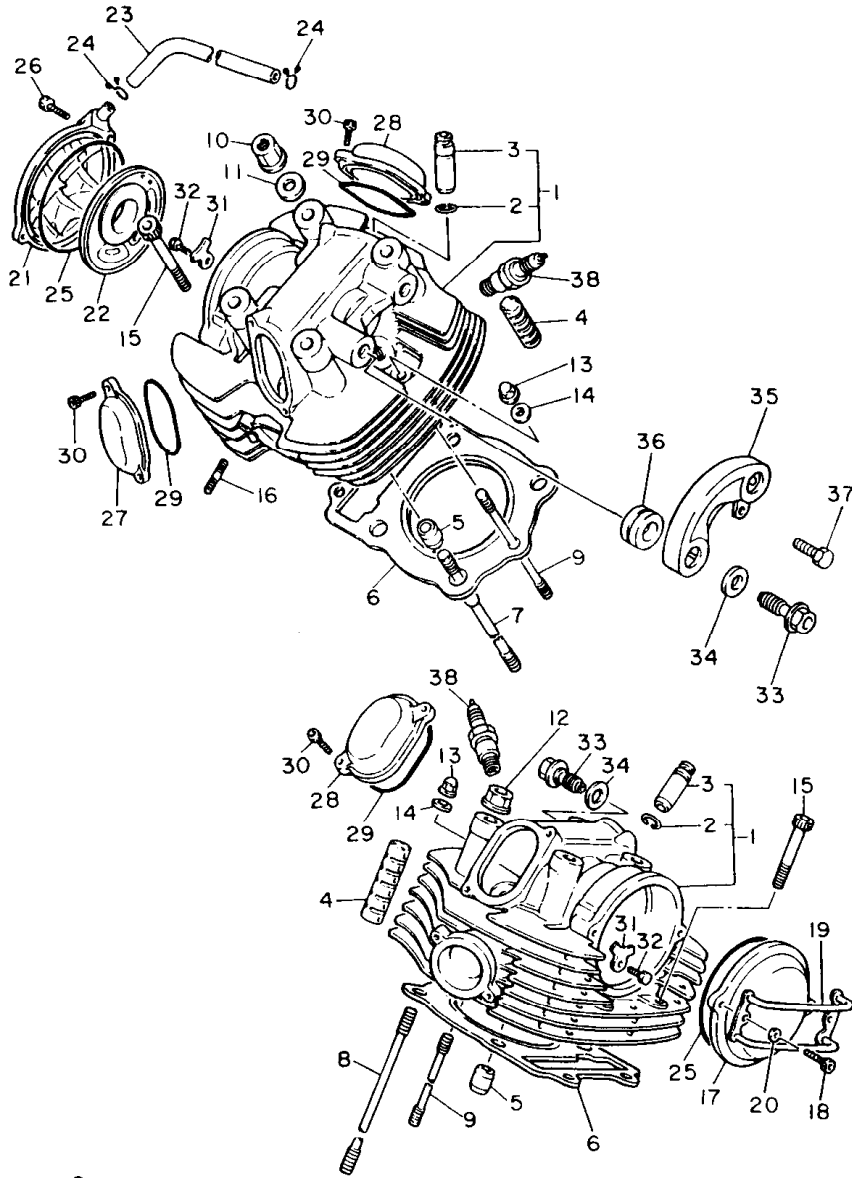

3DR1332-8010

REF. NO.	PART NO.	DESCRIPTION	Q'TY	REMARKS
1	1TF-11102-01	CYLINDER HEAD ASSY	2	
2	93440-14086	.CIRCLIP	2	
3	4X7-11133-10	.GUIDE, IN./EX. VALVE	2	
4	4X7-11127-00	ABSORBER 3	8	
5	91800-06030	PIN, DOWEL	4	
6	42H-11181-00	GASKET, CYLINDER HEAD 1	2	
7	4X7-11363-01	BOLT, CYLINDER HOLDING 3	4	
8	90116-12469	BOLT, STUD	4	
9	90116-10344	BOLT, STUD	2	
10	90179-12326	NUT	4	
11	90201-125A3	WASHER, PLATE	4	
12	90179-12325	NUT	4	
13	90176-10075	NUT, CROWN	2	
14	90201-102G9	WASHER, PLATE	2	
15	91314-08050	BOLT	4	
16	95617-08640	BOLT, STUD	4	
17	42X-11185-01	COVER, CYLINDER HEAD SIDE 1	1	
18	91314-06016	BOLT	2	
19	42X-11152-00	BRACKET, CYLINDER HEAD COVER	1	
20	90202-05208	WASHER, PLATE	2	
21	42X-1111H-01	COVER, CYLINDER HEAD SIDE 4	1	
22	42X-11165-00	PLATE, BREATHER	1	
23	42X-11166-01	PIPE, BREATHER 1	1	
24	90467-14015	CLIP	2	
25	93210-92448	O-RING	2	
26	91314-06025	BOLT	2	
27	42H-11186-01	COVER, CYLINDER HEAD SIDE 2	2	
28	4X7-11187-00	COVER, CYLINDER HEAD SIDE 3	2	

B2

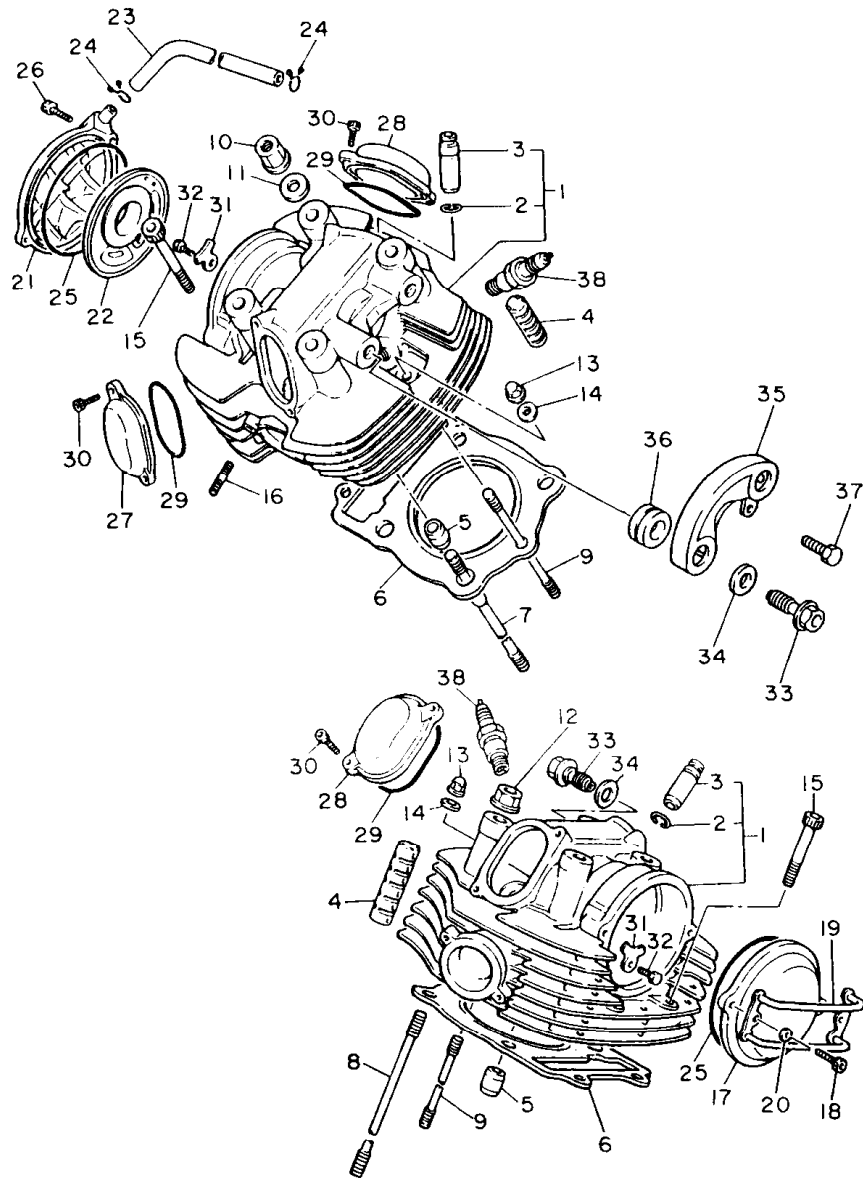

FIG. 1 CYLINDER HEAD

REF. NO.	PART NO.	DESCRIPTION	Q'TY	REMARKS
29	93210-62446	O-RING	4	
30	91314-06016	BOLT	8	
31	4X7-1111F-00	PLATE	2	
32	97017-08020	BOLT	2	
33	90401-16065	BOLT, UNION	2	
34	90430-17168	GASKET	2	
35	1RM-1112E-00	COVER, CYLINDER HEAD 3	1	
36	90480-23444	GROMMET	2	
37	91317-06010	BOLT	1	
38	94701-00218	PLUG, SPARK (NGK BPR7ES)	2	UR
	94701-00220	PLUG, SPARK (ND W22EPR-U)	2	UR



3DR1332-8010

B3

FIG. 2 CYLINDER

REF. NO.	PART NO.	DESCRIPTION	Q'TY	REMARKS
1	1TA-11310-00	CYLINDER	2	
2	93211-01467	O-RING	2	
3	4X7-11161-00	ABSORBER 1	4	
4	90387-087A5	COLLAR	4	
5	91314-06040	BOLT	6	
6	3EG-11351-00	GASKET, CYLINDER	2	
7	4X7-12215-00	CAP, TENSIONER CASE	2	
8	4DW-12213-00	GASKET, TENSIONER CASE	2	
9	91314-06025	BOLT	4	

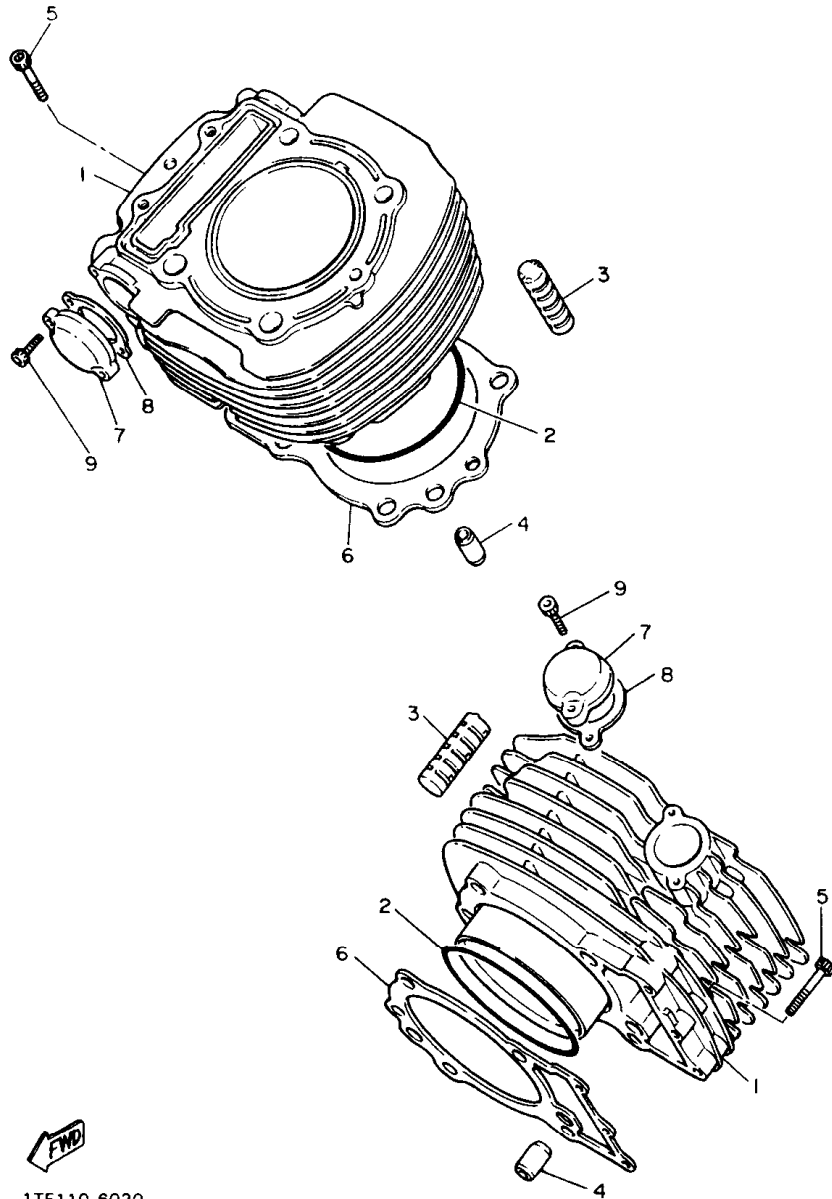

1TE110-6020

B4

FIG. 3 CRANKSHAFT. PISTON

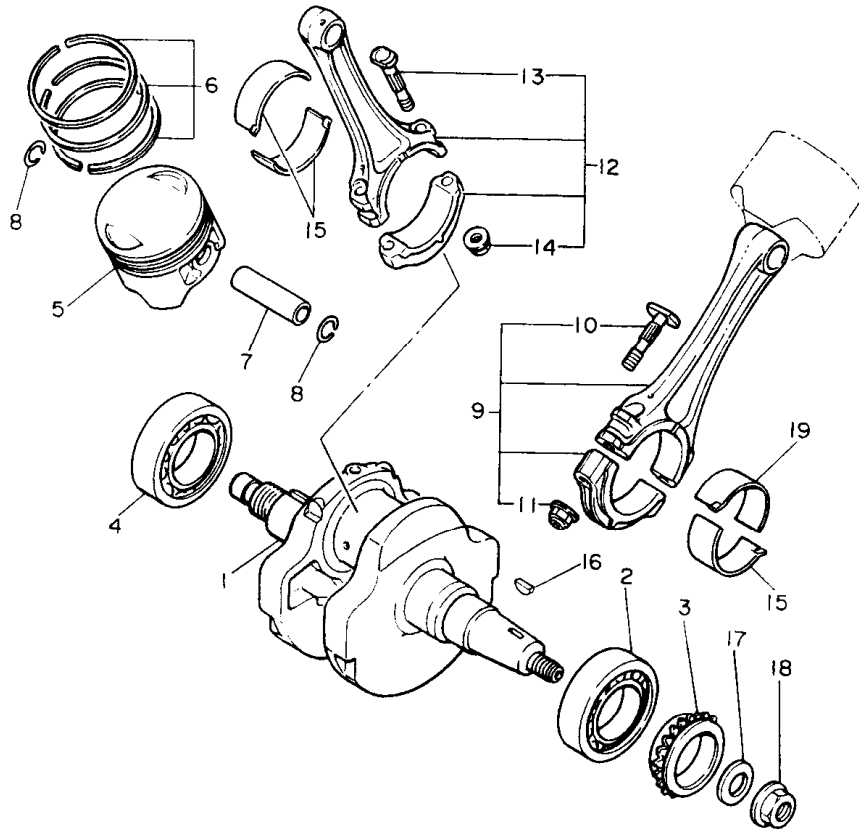

REF. NO.	PART NO.	DESCRIPTION	Q'TY	REMARKS
1	1TA-11411-00	CRANKSHAFT	1	
2	93306-30808	BEARING	1	
3	4X7-13354-00	SPROCKET, DRIVE	1	
4	93306-30808	BEARING	1	
5	1TA-11631-00-A0	PISTON (STD)	2	
	1TA-11636-00	PISTON (0.50MM O/S)	2	AP
	1TA-11638-00	PISTON (1.00MM O/S)	2	AP
6	1TA-11610-00	PISTON RING SET (STD)	2	
	1TA-11610-20	PISTON RING SET (0.50MM O/S)	2	AP
	1TA-11610-40	PISTON RING SET (1.00MM O/S)	2	AP
7	5A8-11633-00	PIN, PISTON	2	
8	93450-24028	CIRCLIP	4	
9	5A8-11650-00	CONNECTING ROD ASSY	1	
10	4X7-11654-01	.BOLT, CONNECTING ROD	2	
11	90179-09379	.NUT	2	
12	5A8-11660-00	CONNECTING ROD ASSY	1	
13	4X7-11654-01	.BOLT, CONNECTING ROD	2	
14	90179-09379	.NUT	2	
15	4X7-11656-00	PLANE BEARING, CONNECTING ROD	3	UR BLUE
	4X7-11656-10	PLANE BEARING, CONNECTING ROD	3	UR BLACK
	4X7-11656-20	PLANE BEARING, CONNECTING ROD	3	UR BROWN
	4X7-11656-30	PLANE BEARING, CONNECTING ROD	3	UR GREEN
	4X7-11656-40	PLANE BEARING, CONNECTING ROD	3	UR YELLOW
16	90280-16053	KEY, WOODRUFF	1	
17	90201-165H4	WASHER, PLATE	1	
18	90179-16448	NUT	1	
19	5G5-11656-00	PLANE BEARING, CONNECTING ROD	1	UR BLACK
	5G5-11656-10	PLANE BEARING, CONNECTING ROD	1	UR BROWN



42G110-4030

B5

FIG. 3 CRANKSHAFT. PISTON

REF. NO.	PART NO.	DESCRIPTION	Q'TY	REMARKS
19	5G5-11656-20	PLANE BEARING, CONNECTING ROD	1	UR GREEN

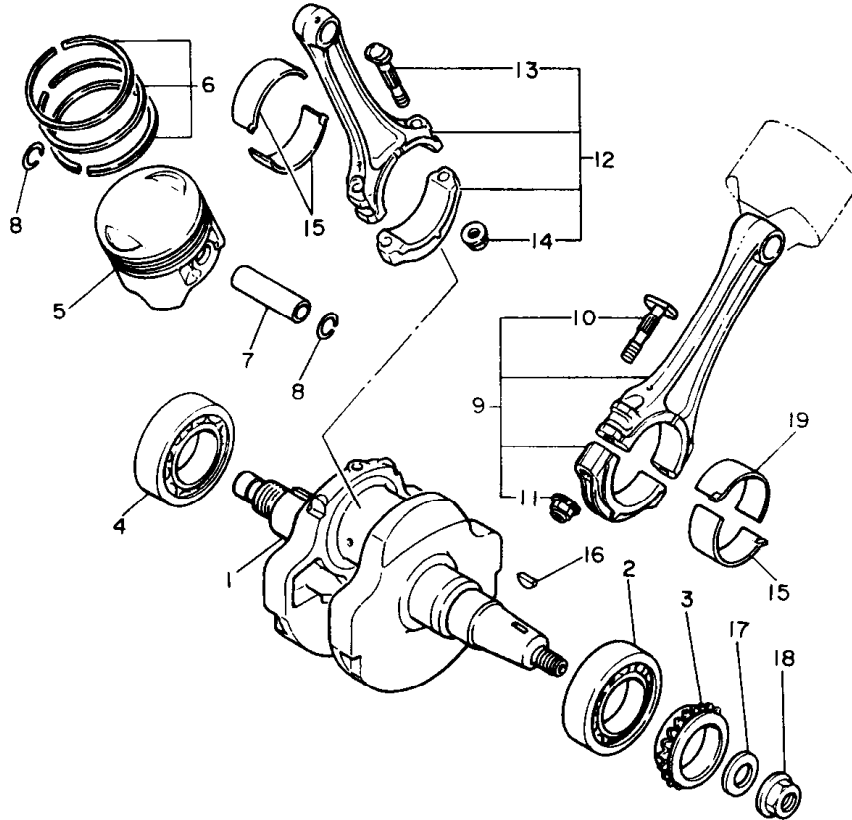



42G110-4030

B6

FIG. 4 VALVE

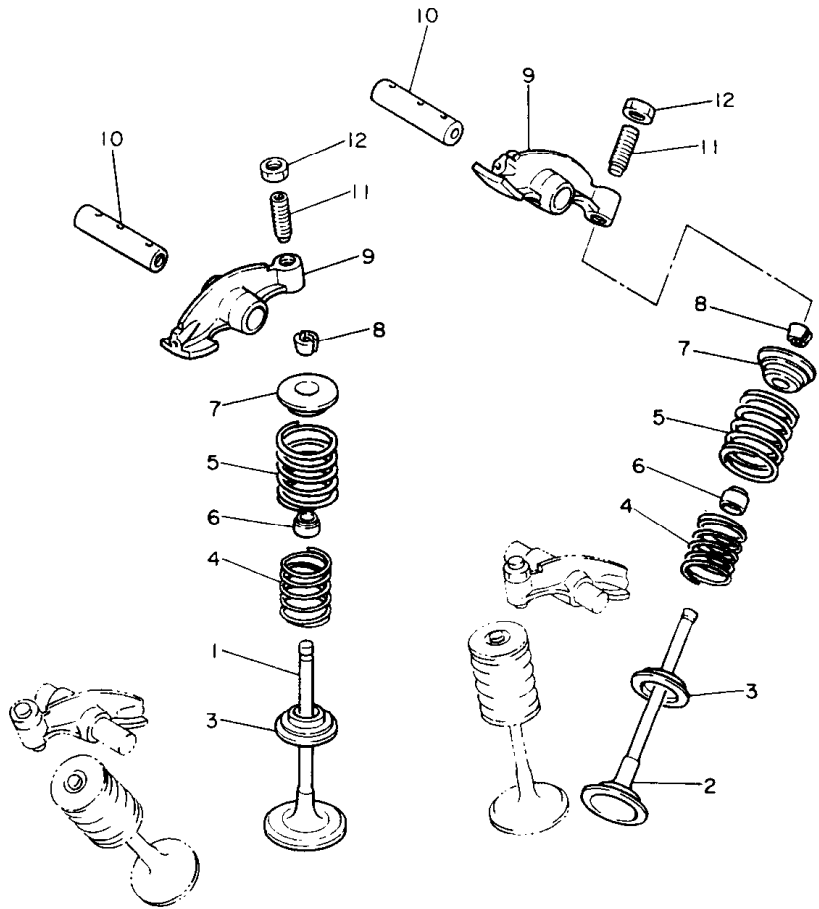
REF. NO.	PART NO.	DESCRIPTION	Q'TY	REMARKS
1	2J2-12111-01	VALVE, INTAKE	2	
2	5A8-12121-00	VALVE, EXHAUST	2	
3	4X7-12116-00	SEAT, VALVE SPRING	4	
4	1TA-12113-00	SPRING, VALVE INNER	4	
5	1TA-12114-00	SPRING, VALVE OUTER	4	
6	341-12119-02	SEAL, VALVE STEM	4	
7	4X7-12117-00	RETAINER, VALVE SPRING	4	
8	4X7-12118-00	COTTER, VALVE	8	
9	42X-12151-00	ARM, VALVE ROCKER	4	
10	4X7-12156-01	SHAFT, ROCKER 2	4	
11	4X7-12159-00	SCREW, VALVE ADJUSTING	4	
12	90170-08173	NUT	4	



5E3171-1050

B7

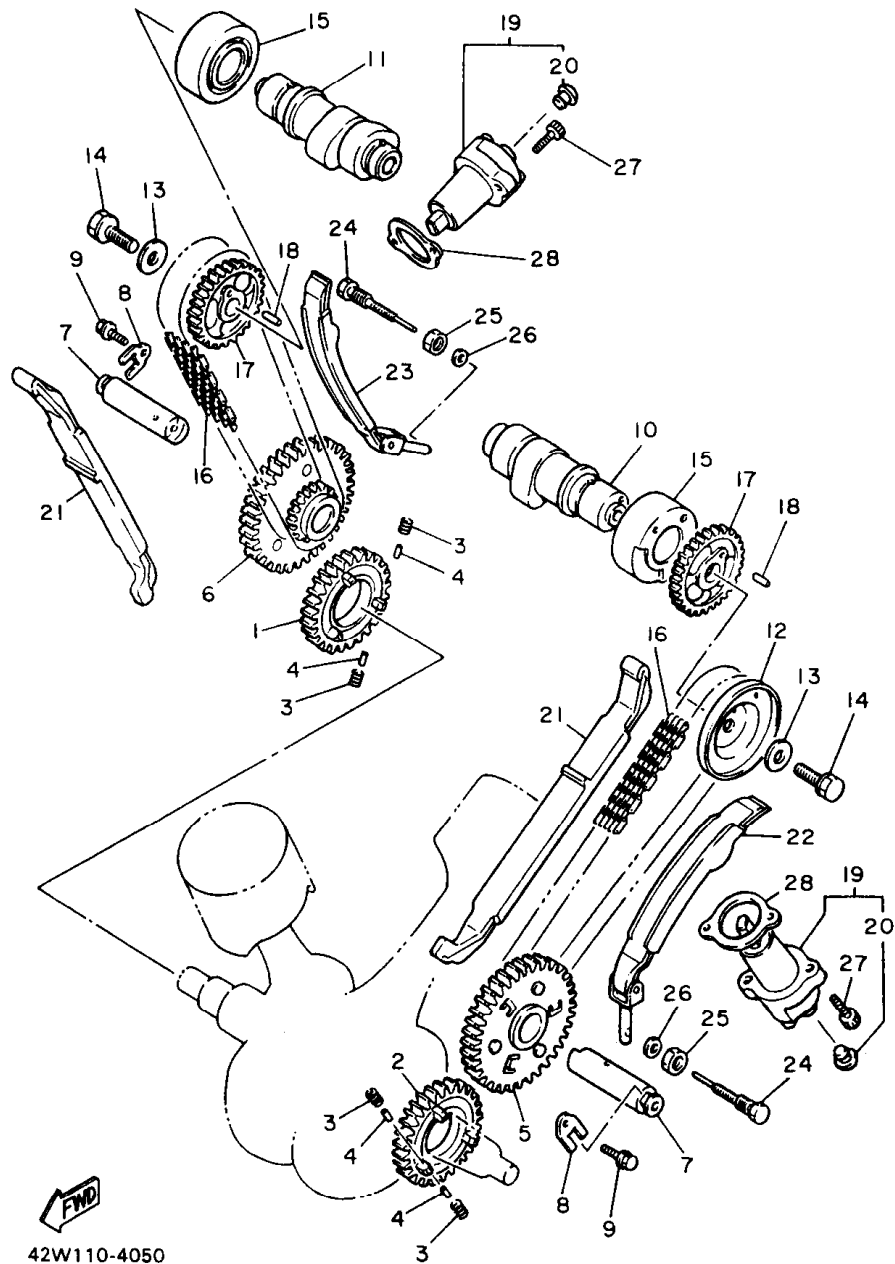

42W110-4050

FIG. 5 CAMSHAFT. CHAIN

REF. NO.	PART NO.	DESCRIPTION	Q'TY	REMARKS
1	4X7-11536-00	GEAR, DRIVE (35T)	1	
2	4X7-11534-00	GEAR, BREAKER DRIVE (35T)	1	
3	90501-21133	SPRING, COMPRESSION	12	
4	93605-10090	PIN, DOWEL	12	
5	4X7-11540-02	CAM CHAIN SPROCKET ASSY 1	1	
6	4X7-11550-01	CAM CHAIN SPROCKET ASSY 2	1	
7	4X7-12247-01	SHAFT, TENSIONER	2	
8	90209-06205	WASHER	2	
9	90105-06154	BOLT, WASHER BASED	2	
10	42H-12171-00	CAMSHAFT 1	1	
11	42H-12181-00	CAMSHAFT 2	1	
12	42X-11145-00	PLATE, BREATHER 2	1	
13	90201-10774	WASHER, PLATE	2	
14	90101-10303	BOLT	2	
15	90380-25125	BUSH, SOLID	2	
16	94590-45098	CHAIN	2	
17	4X7-12176-00	SPROCKET, CAM CHAIN (28T)	2	
18	93604-10011	PIN, DOWEL	2	
19	4X7-12210-01	TENSIONER ASSY, CAM CHAIN	2	
20	90338-06121	.PLUG	1	
21	4X7-12231-00	GUIDE, STOPPER 1	2	
22	4X7-12241-00	GUIDE, STOPPER 2	1	
23	4X7-12221-00	GUIDE, STOPPER 3	1	
24	90109-08592	BOLT	2	
25	95307-08700	NUT	2	
26	92907-06600	WASHER, PLATE	2	
27	91314-06025	BOLT	4	
28	4DW-12213-00	GASKET, TENSIONER CASE	2	

FIG. 6 OIL PUMP

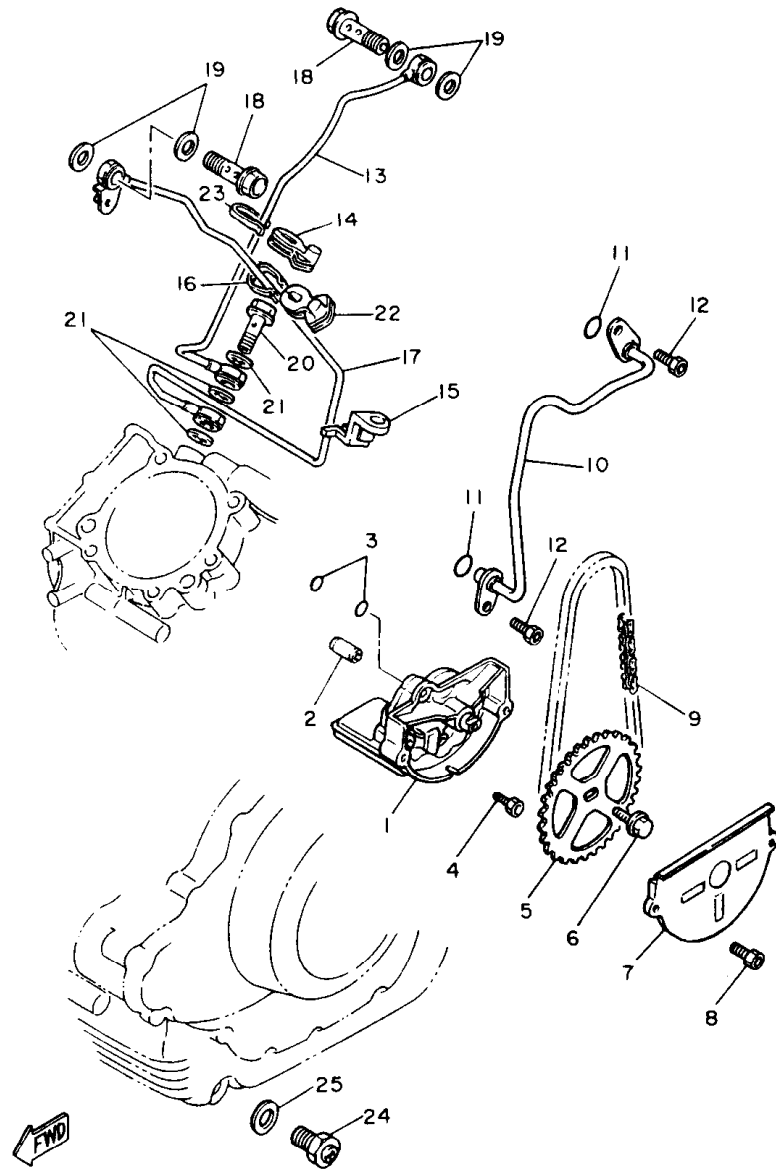

REF. NO.	PART NO.	DESCRIPTION	Q'TY	REMARKS
1	10L-13300-00	OIL PUMP ASSY	1	
2	99510-08016	PIN, DOWEL	1	
3	93210-07438	O-RING	2	
4	91317-06040	BOLT	3	
5	4X7-13355-00	SPROCKET, DRIVEN (35T)	1	
6	90105-06154	BOLT, WASHER BASED	1	
7	10L-13327-00	COVER, PUMP GEAR	1	
8	91317-06010	BOLT	2	
9	94580-25066	CHAIN	1	
10	4X7-13171-00	PIPE, DELIVERY 2	1	
11	93210-07438	O-RING	2	
12	91317-06010	BOLT	2	
13	4X7-13405-00	OIL PIPE COMP. 1	1	
14	4X7-15485-01	CLAMP	1	
15	4X7-15484-00	CLAMP 2	1	
16	90468-05113	CLIP	1	
17	1RM-13406-00	OIL PIPE COMP. 2	1	
18	90401-16067	BOLT, UNION	2	
19	90430-17168	GASKET	4	
20	90401-10102	BOLT, UNION	1	
21	90430-15169	GASKET	3	
22	4X7-15485-01	CLAMP	1	
23	90468-05113	CLIP	1	
24	3JL-13455-00	PLUG	1	
25	214-11198-01	GASKET	1	

1RR110-6060

FIG. 7 OIL CLEANER

REF. NO.	PART NO.	DESCRIPTION	Q'TY	REMARKS
1	4X7-13440-90	ELEMENT ASSY, OIL CLEANER	1	
2	93210-56459	O-RING	1	
3	93210-54452	O-RING	1	
4	1RM-13447-00	COVER, OIL ELEMENT	1	
5	93210-07135	O-RING	1	
6	90109-06667	BOLT	1	
7	91314-06020	BOLT	1	
8	91314-06050	BOLT	1	
9	11H-13490-00	RELIEF VALVE ASSY	1	
10	93210-10096	O-RING	1	
11	90462-10098	CLAMP	1	

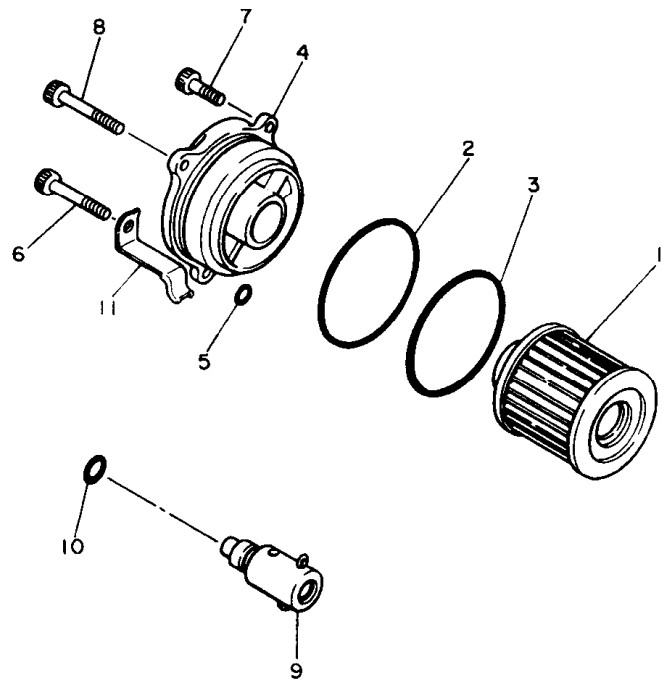

5E3171-1070

FIG. 8 INTAKE

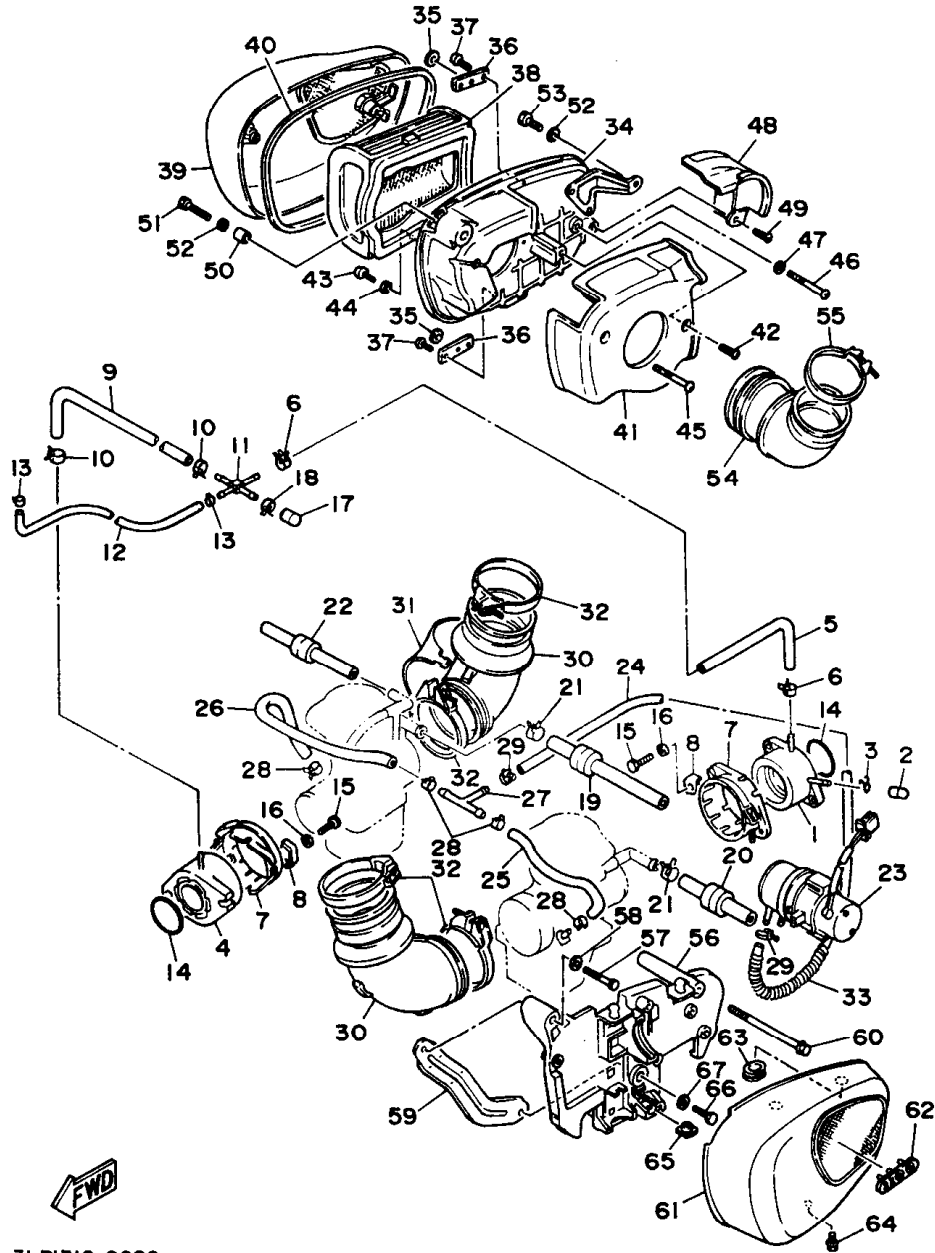

REF. NO.	PART NO.	DESCRIPTION	Q'TY	REMARKS
1	1TA-13586-00	JOINT, CARBURETOR 1	1	
2	16G-13569-00	PLUG, BLIND	1	
3	90467-10039	CLIP	1	
4	24M-13586-01	JOINT, CARBURETOR 1	1	
5	3CG-13542-00	HOSE, VACUUM SENSING 1	1	
6	90467-08092	CLIP	2	
7	42X-13564-01	COVER, MANIFOLD	2	
8	42X-13578-00	WASHER	2	
9	42X-13544-00	HOSE, VACUUM SENSING 2	1	
10	90467-08092	CLIP	2	
11	1TA-13595-00	JOINT	1	
12	42H-13532-00	HOSE, VACUUM SENSING 3	1	
13	90467-07093	CLIP	2	
14	93210-44545	O-RING	2	
15	97017-06020	BOLT	4	
16	92907-06600	WASHER, PLATE	4	
17	16G-13569-00	PLUG, BLIND	1	
18	90467-10039	CLIP	1	
19	3CG-14197-00	PIPE	1	
20	3CG-14987-00	HOSE	1	
21	90467-14057	CLIP	2	
22	3CG-14396-00	PIPE	1	
23	42H-13907-00	FUEL PUMP COMP.	1	
24	42H-13971-00	PIPE, FUEL 1	1	
25	1TA-14349-00	PIPE	1	
26	1TA-14348-00	PIPE 1	1	
27	90413-07023	WAY 3	1	
28	90467-10091	CLIP	4	



3LPI310-9080

B11

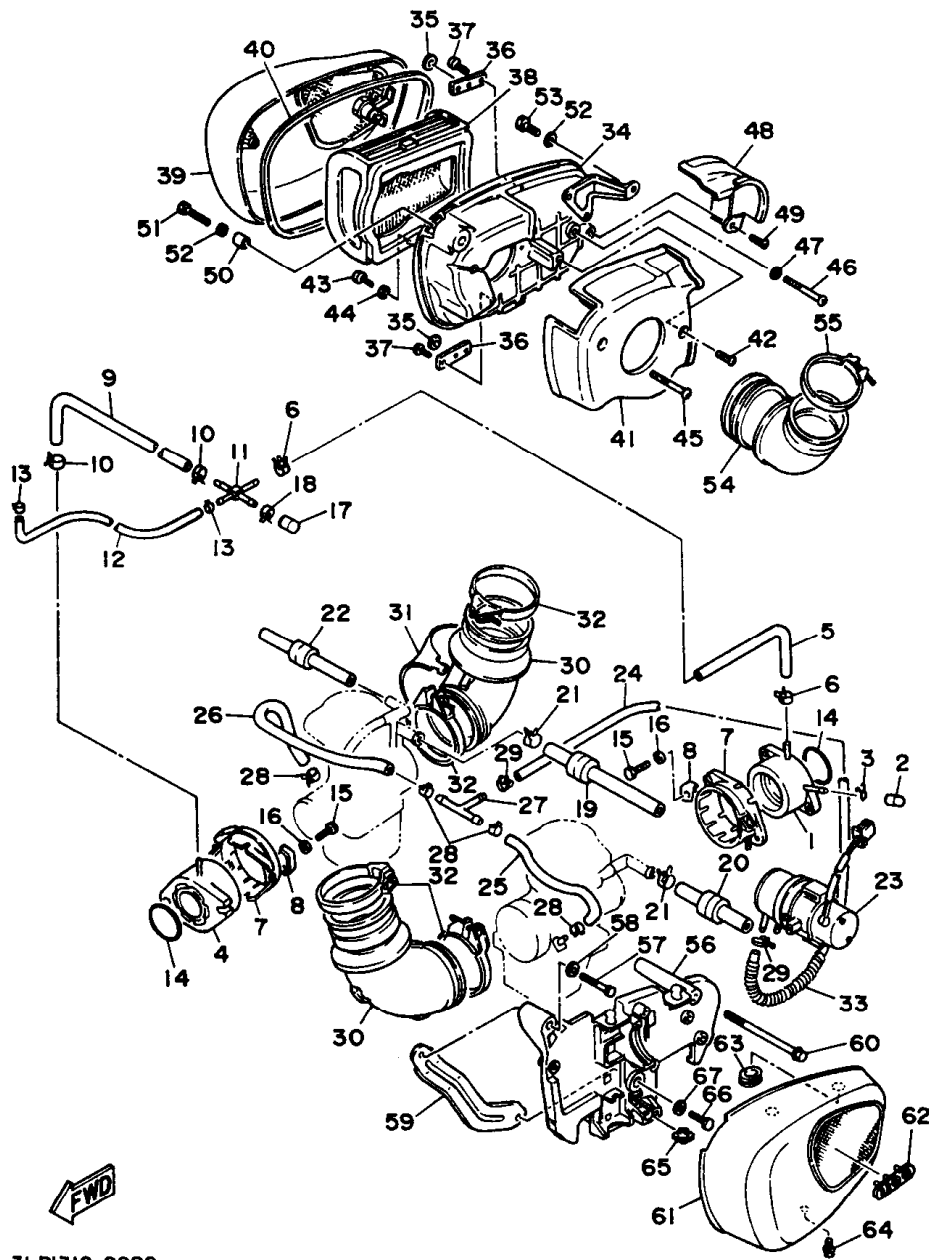

3LP1310-9080

FIG. 8 INTAKE

REF. NO.	PART NO.	DESCRIPTION	Q'TY	REMARKS
29	90460-12256	CLAMP, HOSE	2	
30	10L-14453-01	JOINT, AIR CLEANER 1	2	
31	10L-14407-00	COVER, JOINT	1	
32	90460-65195	CLAMP, HOSE	4	
33	90501-100F8	SPRING, COMPRESSION	1	
34	42X-14401-01	AIR CLEANER CASE ASSY	1	
35	92907-04600	WASHER, PLATE	2	
36	42X-14477-00	PLATE	2	
37	97707-40112	SCREW, TAPPING	4	
38	42X-14451-00	ELEMENT, AIR CLEANER	1	
39	1RM-14422-00	CAP, CLEANER CASE 2	1	
40	42X-14452-00	SEAL	1	
41	1TA-1441A-00	COVER, CLEANER CASE 1	1	
42	97707-50508	SCREW, TAPPING	1	
43	98507-05012	SCREW, PAN HEAD	1	
44	92907-05600	WASHER	1	
45	98507-06080	SCREW, PAN HEAD	1	
46	98507-06050	SCREW, PAN HEAD	1	
47	92907-06600	WASHER, PLATE	1	
48	1TA-1441E-00	COVER, CLEANER CASE 2	1	
49	97707-50508	SCREW, TAPPING	1	
50	90387-07598	COLLAR	1	
51	91317-06030	BOLT	1	
52	92907-06200	WASHER, PLAIN	2	
53	91317-06012	BOLT	1	
54	42X-14485-00	PIPE, JOINT	1	
55	90460-65195	CLAMP, HOSE	1	
56	42X-14663-02	PLATE, AIR CLEANER	1	

B12

FIG. 8 INTAKE

REF. NO.	PART NO.	DESCRIPTION	Q'TY	REMARKS
57	91317-06090	BOLT	1	
58	92907-06200	WASHER, PLAIN	1	
59	42X-14484-00	PLATE, CLEANER CASE FITTING	1	
60	95807-06025	BOLT, FLANGE	1	
61	1RM-14603-00	COVER 1	1	
62	1TA-1441K-00	EMBLEM	1	
63	90480-14074	GROMMET	2	
64	95807-06014	BOLT, FLANGE	1	
65	12R-14484-01	PLATE, CLEANER CASE FITTING	1	
66	91317-06035	BOLT	1	
67	92907-06200	WASHER, PLAIN	1	

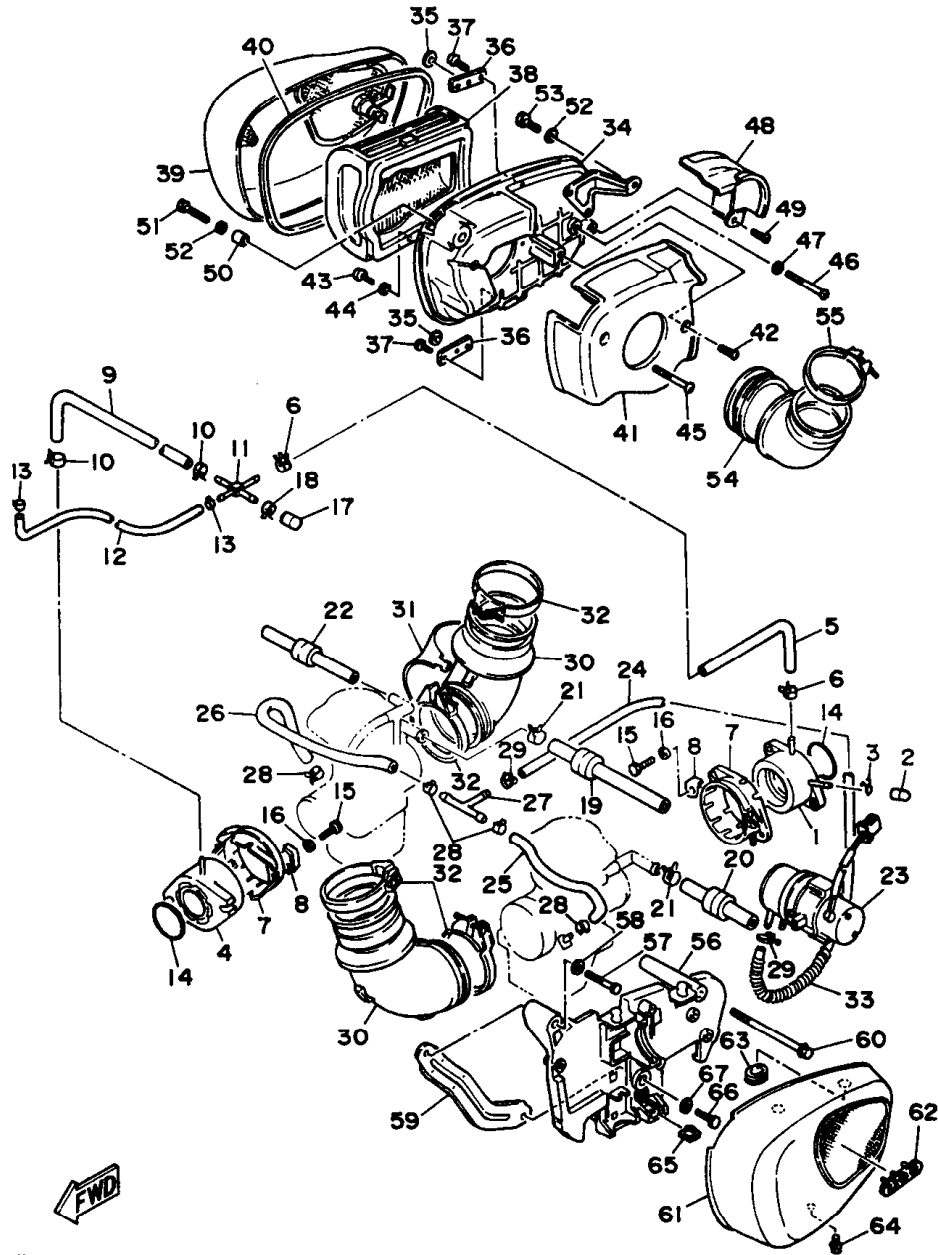

3LPI310-9080

B13

FIG. 9 CARBURETOR

REF. NO.	PART NO.	DESCRIPTION	Q'TY	REMARKS
1	3LP-14900-01	CARBURETOR ASSY	1	
2	3LP-14901-01	..CARBURETOR ASSY 1	1	
3	3LP-14902-01	..CARBURETOR ASSY 2	1	
4	3CF-14984-01	..GASKET, FLOAT CHAMBER	1	
5	3CF-14107-15	..NEEDLE VALVE SET	1	
6	3CN-1490J-00	..NEEDLE SET	1	
7	3CF-14940-00	..DIAPHRAGM ASSY	1	
8	3CF-14933-00	..SPRING, DIAPHRAGM	1	
9	12R-14105-00	..PILOT SCREW SET	1	
10	537-14186-00	..PIN, FLOAT	1	
11	2VA-14185-00	..FLOAT	1	
12	137-14153-00	..WASHER, MAIN JET	1	
13	620-14231-25-A0	..JET, MAIN (#125)	1	UR
	620-1423A-75	..JET, MAIN (#122.5)	1	UR
14	3CF-14141-93	..NOZZLE, MAIN	1	
15	4G0-14142-40	..JET, PILOT (#40)	1	
16	3G2-14231-12	..JET, POWER (#60)	1	
17	98507-05010	..SCREW, PAN HEAD	4	
18	98580-04008	..SCREW, PAN HEAD	2	
19	3CF-1490H-00	..DIAPHRAGM SET, 5	1	
20	1HX-14231-28	..JET, MAIN (#140)	1	
21	3CF-1410A-00	..STARTER SET	1	
22	98580-05014	..SCREW, PAN HEAD	4	
23	92990-05100	..WASHER, SPRING	4	
24	12R-14191-00	..PLUG, DRAIN	1	
25	2JU-14937-00	..CLIP	1	
26	22F-14991-00	..CAP	1	
27	3CF-14251-00	..NIPPLE	1	

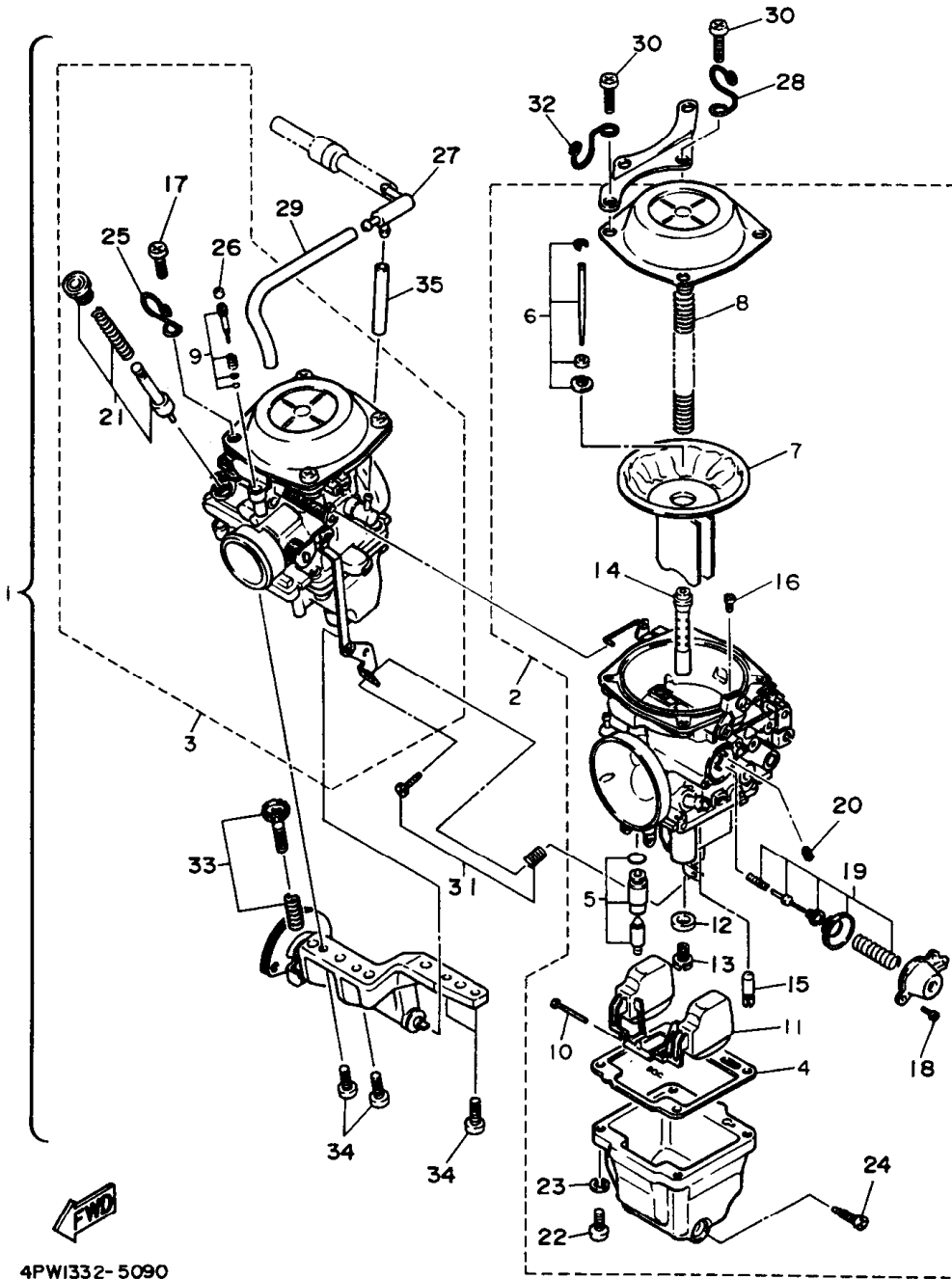

4PW1332-5090

B14

FIG. 9 CARBURETOR

REF. NO.	PART NO.	DESCRIPTION	Q'TY	REMARKS
28	3CF-14937-00	.CLIP	1	
29	3CG-14197-00	.PIPE	1	
30	98507-05012	.SCREW, PAN HEAD	4	
31	3CF-1490K-00	.STOP SCREW SET	1	
32	3CF-14919-00	.CLIP	1	
33	3CF-14103-01	.THROTTLE SCREW SET	1	
34	98580-05014	.SCREW, PAN HEAD	4	
35	3CF-14197-00	.PIPE	1	

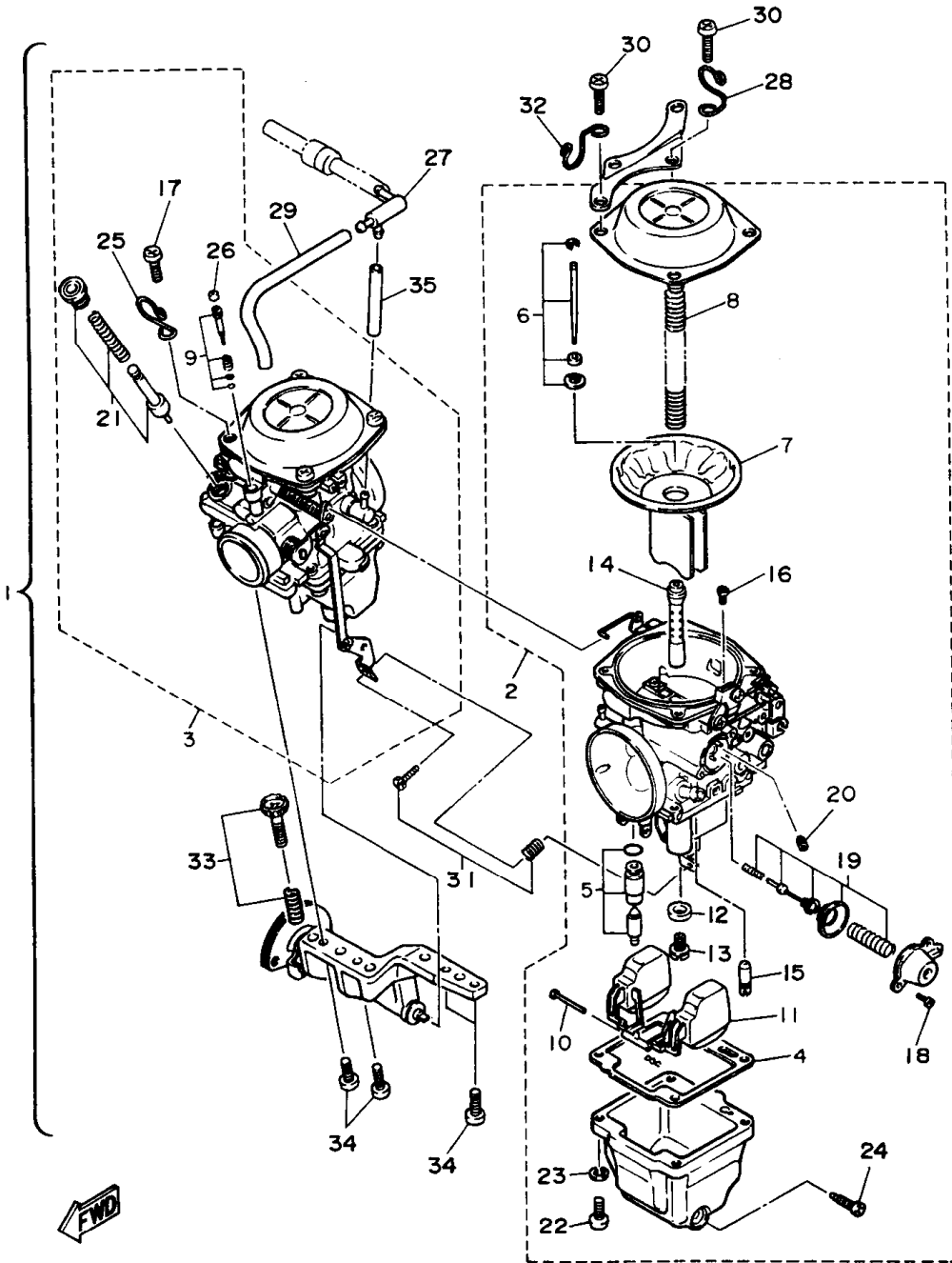

4PW1332-5090

B15

FIG. 10 EXHAUST

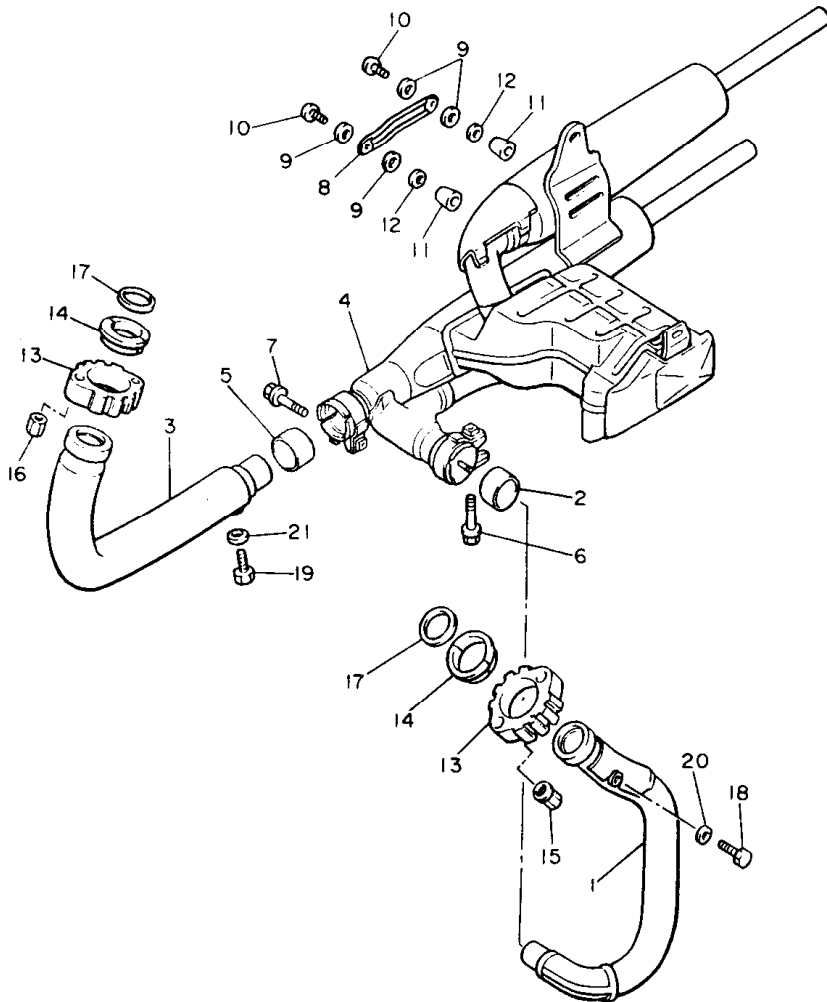

REF. NO.	PART NO.	DESCRIPTION	Q'TY	REMARKS
1	42H-14611-00	PIPE, EXHAUST 1	1	
2	3EG-14714-00	GASKET, MUFFLER	1	
3	1TA-14621-00	PIPE, EXHAUST 2	1	
4	2TN-14711-01	MUFFLER 1	1	
5	3YF-14755-00	GASKET, SILENCER	1	
6	95027-08045	BOLT	1	
7	95027-08045	BOLT	1	
8	42X-14748-01	PROTECTOR, MUFFLER 4	1	
9	4BD-14766-00	WASHER, PROTECTOR	4	
10	98904-06010	SCREW, BIND	2	
11	42X-1479H-00	COVER, 1	2	
12	92907-06200	WASHER, PLAIN	2	
13	57A-14612-01	NUT, RING	2	
14	42X-1468A-00	RING, SILENCER 1	2	
15	90179-08210	NUT	2	
16	90179-08507	NUT	2	
17	3EG-14613-00	GASKET, EXHAUST PIPE	2	
18	90101-06576	BOLT	1	
19	90101-06576	BOLT	1	
20	92907-06600	WASHER, PLATE	1	
21	92907-06600	WASHER, PLATE	1	



2TN361-7100

FIG. 11 CRANKCASE

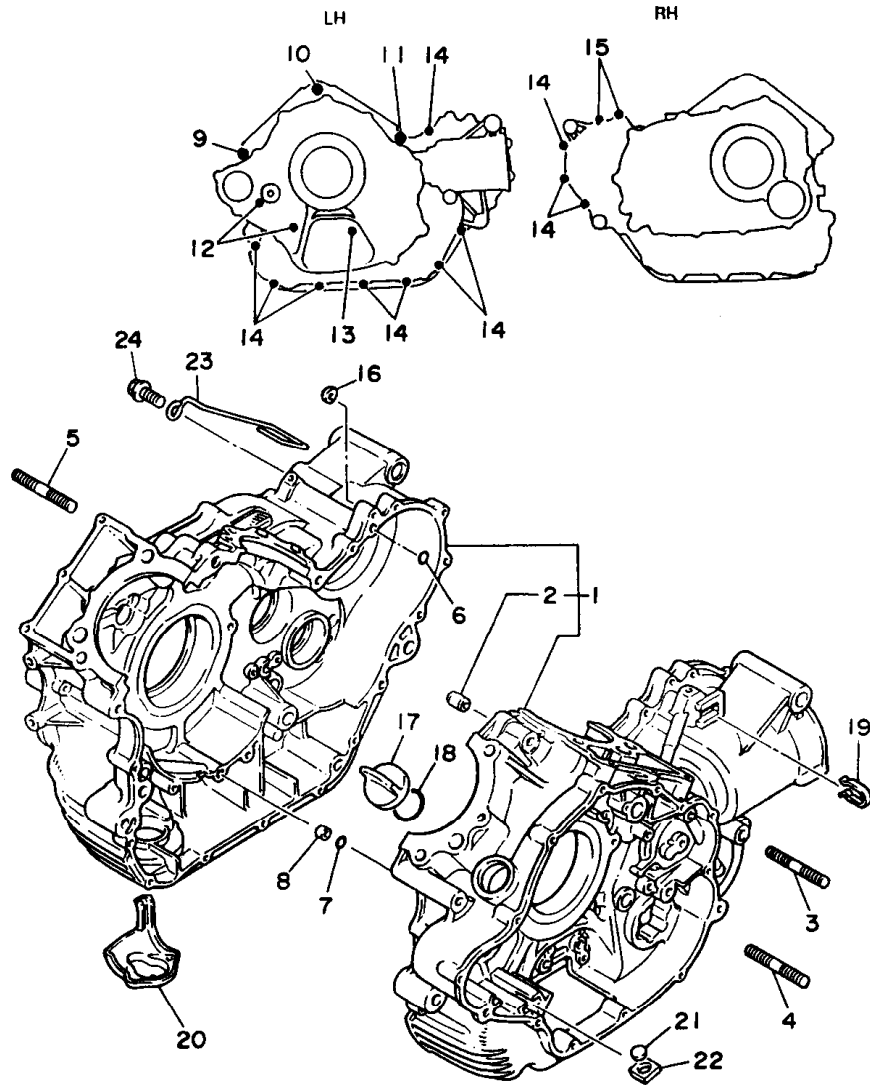

REF. NO.	PART NO.	DESCRIPTION	Q'TY	REMARKS
1	42H-15100-02	CRANKCASE ASSY	1	
2	99510-14016	.PIN, DOWEL	3	
3	95617-10620	BOLT, STUD	1	
4	95617-10620	BOLT, STUD	1	
5	95617-10670	BOLT, STUD	1	
6	93210-07438	O-RING	1	
7	93210-07135	O-RING	1	
8	90387-064E8	COLLAR	1	
9	91317-10100	BOLT	1	
10	91317-10070	BOLT	1	
11	91317-10060	BOLT	1	
12	91317-06080	BOLT	2	
13	91317-06055	BOLT	1	
14	91317-06030	BOLT	11	
15	91314-06030	BOLT	2	
16	90430-06014	GASKET	1	
17	57A-15363-11	PLUG, OIL	1	
18	93210-29198	O-RING	1	
19	90465-10168	CLAMP	1	
20	4X7-15491-00	PROTECTOR	1	
21	4X7-13419-00	PLUG	1	
22	90480-20302	GROMMET	1	
23	42X-21164-00	HOLDER, CABLE	1	
24	90105-10275	BOLT, WASHER BASED	1	



3LP7300-4110

C3

FIG. 12 CRANKCASE COVER 1

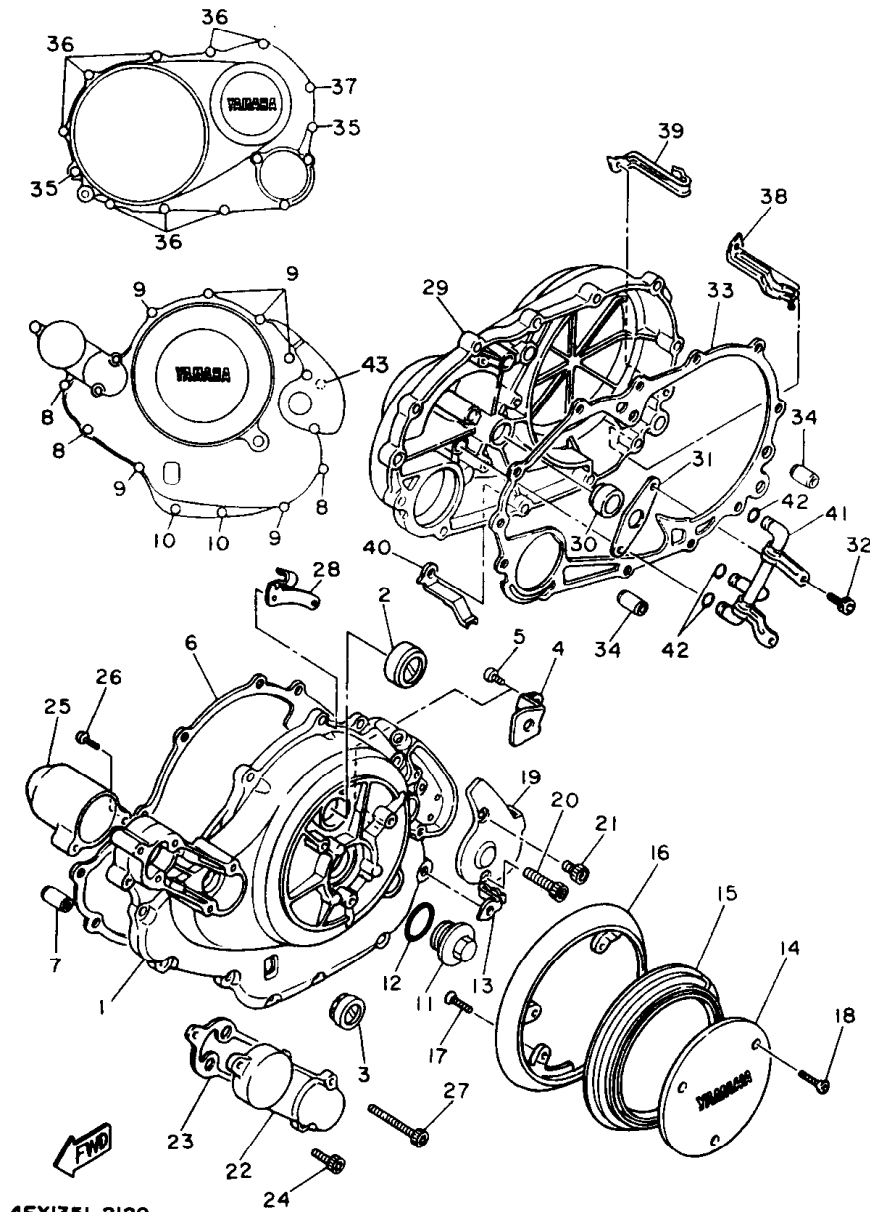

REF. NO.	PART NO.	DESCRIPTION	Q'TY	REMARKS
1	1RM-15411-01	COVER, CRANKCASE 1	1	
2	4X7-15361-00	GAUGE, LEVEL	1	
3	2H7-15361-00	GAUGE, LEVEL	1	
4	90465-08309	CLAMP	1	
5	98507-06010	SCREW, FLAT	1	
6	3EG-15451-00	GASKET, CRANKCASE COVER 1	1	
7	99530-10014	PIN, DOWEL	2	
8	91314-06040	BOLT	3	
9	91314-06030	BOLT	6	
10	91314-06020	BOLT	2	
11	119-11186-00	COVER, CYLINDER HEAD SIDE 2	1	
12	93210-32172	O-RING	1	
13	90462-08076	CLAMP	1	
14	1RM-15415-01	COVER, GENERATOR	1	
15	1RM-15455-00	GASKET 1	1	
16	3JK-15425-00	COVER, GENERATOR 2	1	
17	98704-06016	SCREW, FLAT	3	
18	98707-06014	SCREW, FLAT	3	
19	42X-15417-01	COVER, CAP	1	
20	91314-06055	BOLT	1	
21	91314-06016	BOLT	1	
22	1RM-15419-00	COVER, SHIFTER 1	1	
23	3EG-15459-00	GASKET, SHIFTER COVER	1	
24	91314-06016	BOLT	2	
25	3CG-15429-00	COVER, SHIFTER	1	
26	98507-06030	SCREW, PAN HEAD	2	
27	91314-06065	BOLT	1	
28	42X-15441-00	HOLDER, CLUTCH CABLE	1	

C4

FIG. 12 CRANKCASE COVER 1

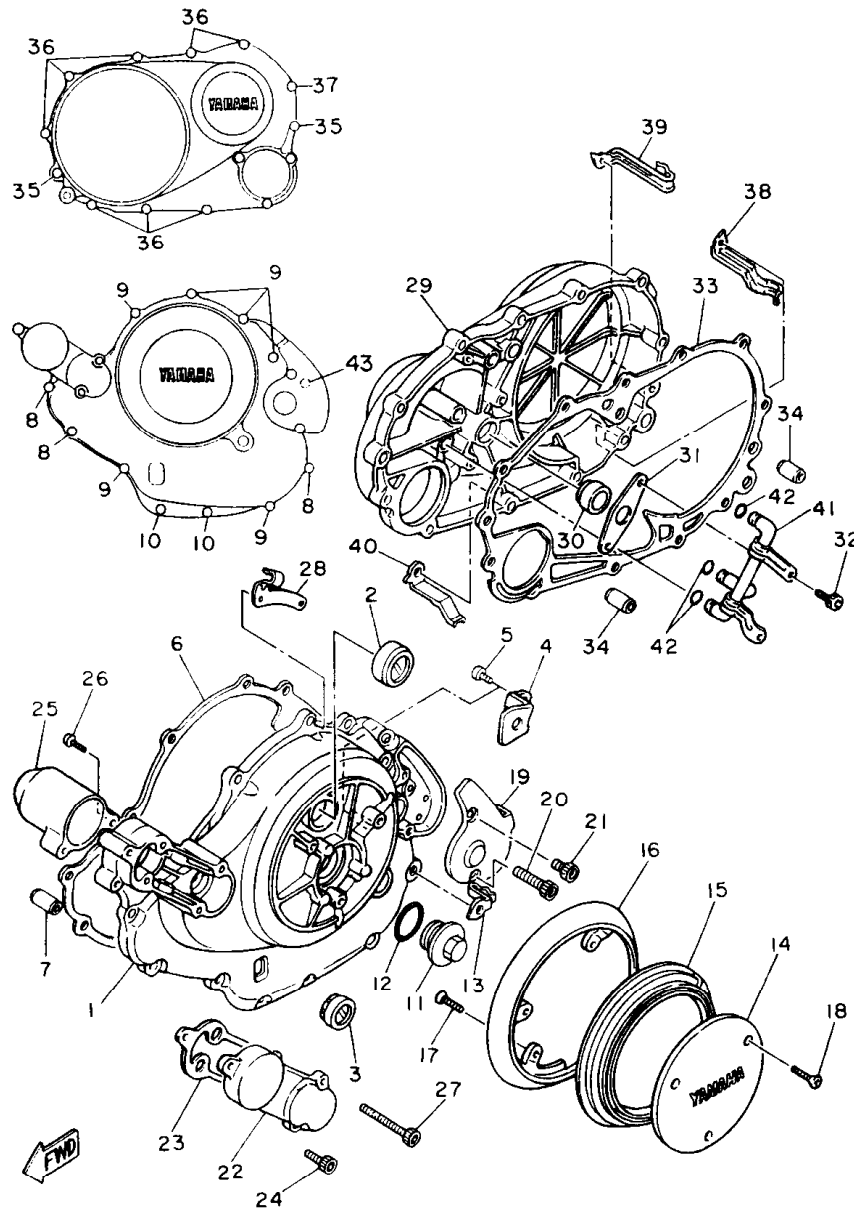

REF. NO.	PART NO.	DESCRIPTION	Q'TY	REMARKS
29	3JK-W1542-01	COVER, CRANKCASE 3	1	
30	93101-14102	OIL SEAL	1	
31	4X7-15388-00	PLATE, BEARING COVER	1	
32	91317-06016	BOLT	2	
33	3EG-15462-00	GASKET, CRANKCASE COVER 3	1	
34	99530-10020	PIN, DOWEL	2	
35	91314-06040	BOLT	2	
36	91314-06025	BOLT	8	
37	90380-06030	BOLT	1	
38	90462-10143	CLAMP	1	
39	90462-10085	CLAMP	2	
40	90462-12142	CLAMP	1	
41	1RM-13161-00	PIPE, DELIVERY 1	1	
42	93210-07438	O-RING	3	
43	90110-06093	BOLT, HEXAGON SOCKET HEAD	1	

4FY1351-2120

FIG. 13 STARTER CLUTCH

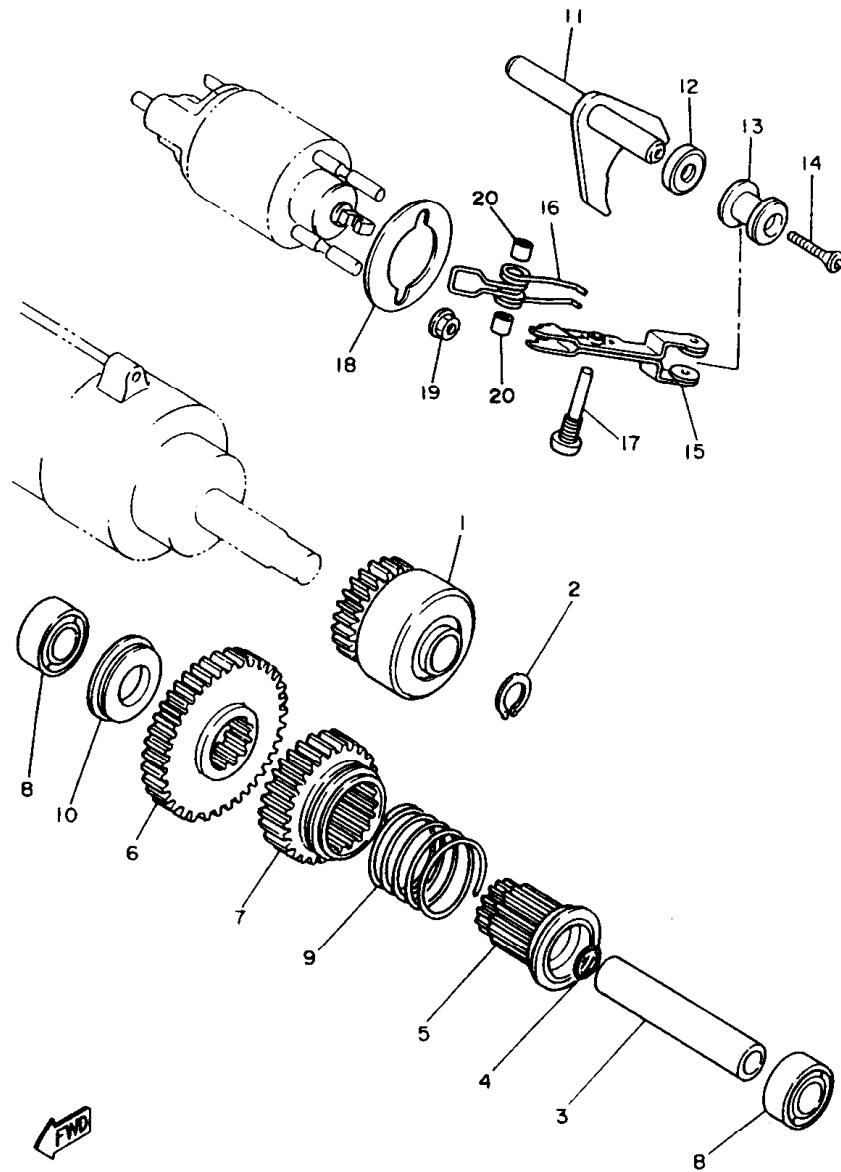

REF. NO.	PART NO.	DESCRIPTION	Q'TY	REMARKS
1	3LP-15570-00	STARTER CLUTCH ASSY	1	
2	99009-13400	CIRCLIP	1	
3	4X7-15521-00	SHAFT 1	1	
4	93210-14104	O-RING	1	
5	3LP-15524-10	WHEEL, STARTER (23T)	1	
6	1TA-15512-00	GEAR, IDLER 1	1	
7	3LP-15517-10	GEAR, IDLER 2 (27T)	1	
8	90387-172E5	COLLAR	2	
9	90501-15636	SPRING, COMPRESSION	1	
10	90387-170E5	COLLAR	1	
11	5A8-15550-00	DRIVE LEVER ASSY	1	
12	93102-10247	OIL SEAL	1	
13	5A8-15542-01	COLLAR 2	1	
14	90151-06013	SCREW, COUNTERSUNK	1	
15	5A8-15556-00	LEVER, DRIVE	1	
16	90508-26494	SPRING, TORSION	1	
17	90149-08166	SCREW	1	
18	3EG-15568-00	GASKET	1	
19	95707-06500	NUT, FLANGE	2	
20	90387-0801M	COLLAR	2	

4GK1361-3130

C6

FIG. 14 CLUTCH

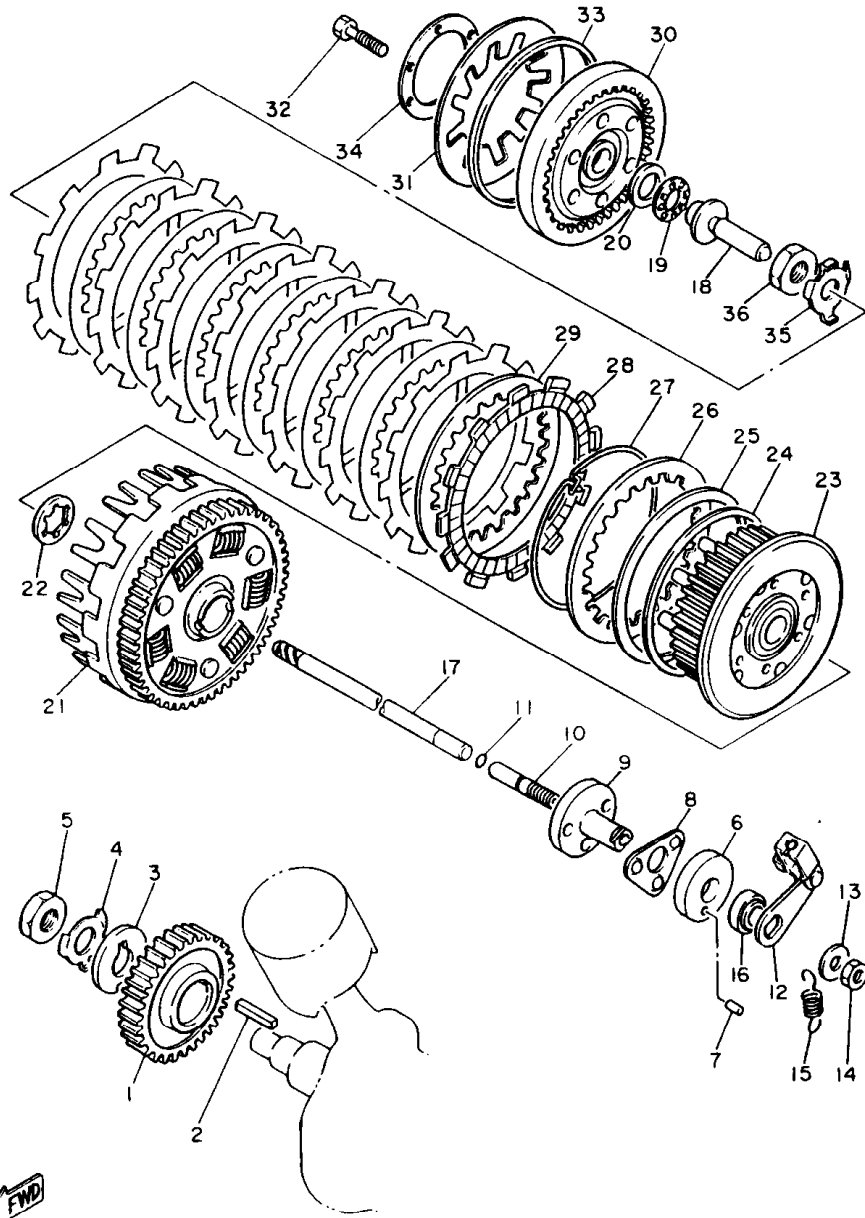

REF. NO.	PART NO.	DESCRIPTION	Q'TY	REMARKS
1	4X7-16111-00	GEAR, PRIMARY DRIVE (47T)	1	
2	90282-07042	KEY, STRAIGHT	1	
3	90214-20022	WASHER, CLAW	1	
4	90215-20182	WASHER, LOCK	1	
5	90170-20274	NUT	1	
6	2H7-16396-00	HOUSING, PUSH SCREW	1	
7	93606-07082	PIN, DOWEL	1	
8	2H7-16395-01	RETAINER, BALL	1	
9	2H7-16341-00	SCREW, PUSH	1	
10	2H7-16343-00	SCREW, ADJUSTING	1	
11	93210-48364	O-RING	1	
12	4X7-16340-00	PUSH LEVER ASSY	1	
13	92907-08200	WASHER, PLAIN	1	
14	95307-08700	NUT	1	
15	90506-10069	SPRING, TENSION	1	
16	93104-14059	OIL SEAL	1	
17	4X7-16357-00	ROD, PUSH 2	1	
18	4X7-16356-00	ROD, PUSH 1	1	
19	93340-21505	BEARING, THRUST	1	
20	90201-154E9	WASHER, PLATE	1	
21	4X7-16150-02	PRIMARY DRIVEN GEAR COMP.	1	
22	3Y1-16154-00	PLATE, THRUST 1	1	
23	1TA-16371-00	BOSS, CLUTCH	1	
24	4X7-16384-00	PLATE, SEAT	1	
25	4X7-16383-01	SPRING, CLUTCH BOSS	1	
26	4X7-16324-00	PLATE, CLUTCH 1	1	
27	4X7-16385-00	RING, CLUTCH BOSS	1	
28	22U-16321-00	PLATE, FRICTION	8	

FWD

1TE110-6140

FIG. 14 CLUTCH

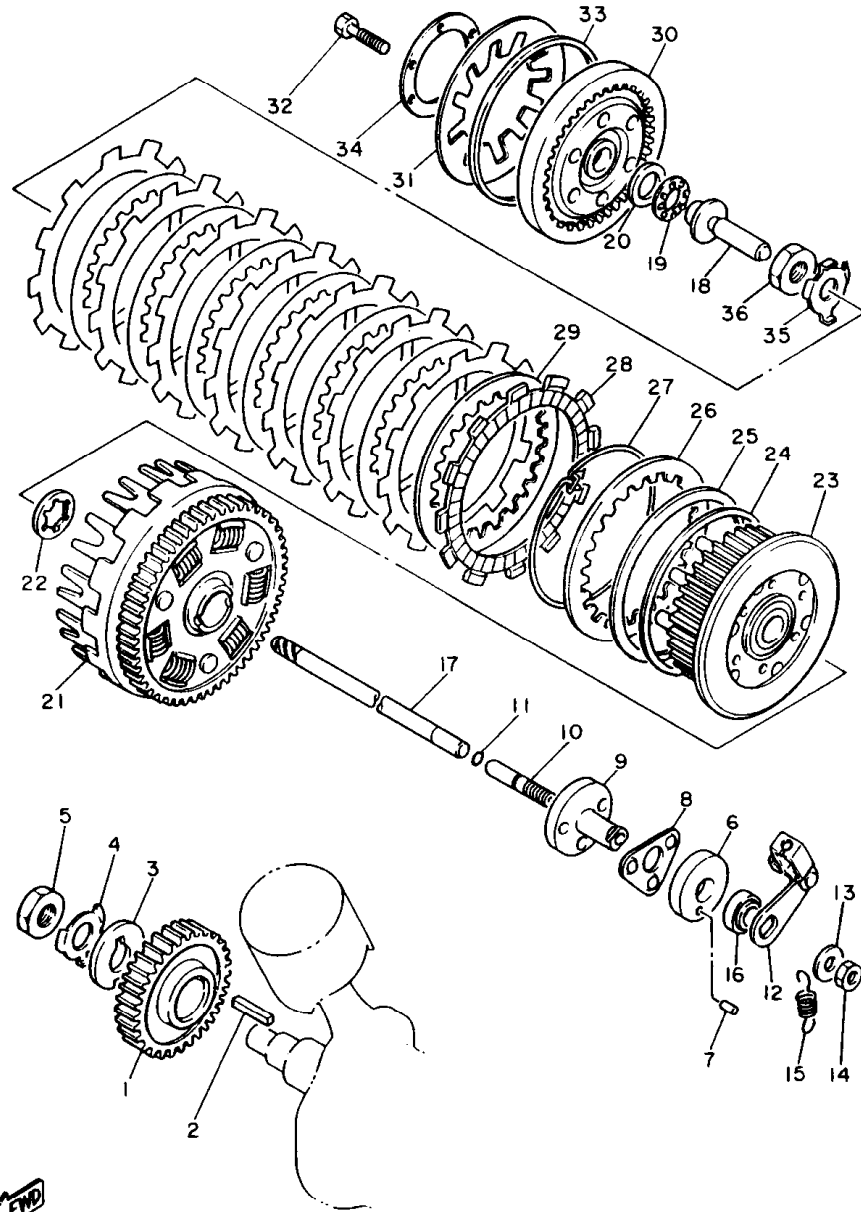

REF. NO.	PART NO.	DESCRIPTION	Q'TY	REMARKS
29	1TA-16325-00	PLATE, CLUTCH 2	7	
30	1TA-16351-00	PLATE, PRESSURE 1	1	
31	1TA-16334-00	SPRING, CLUTCH 2	1	
32	97017-06025	BOLT	6	
33	1TA-16335-00	HOUSING, SPRING	1	
34	1TA-16352-00	PLATE, PRESSURE 2	1	
35	90215-20231	WASHER, LOCK	1	
36	90170-20327	NUT	1	



1TE110-6140

FIG. 15 TRANSMISSION

REF. NO.	PART NO.	DESCRIPTION	Q'TY	REMARKS
1	1TA-17411-00	AXLE, MAIN	1	
2	4X7-17141-00	GEAR, 4TH PINION (31T)	1	
3	90209-22191	WASHER	1	
4	93410-25010	CIRCLIP	1	
5	4X7-17121-00	GEAR, 2ND/3RD PINION (24/28T)	1	
6	42X-17151-00	GEAR, 5TH PINION (34T)	1	
7	90201-20276	WASHER, PLATE (1.0T)	1	
8	99009-20400	CIRCLIP	1	
9	93306-30525	BEARING (B6305)	1	
10	93104-20068	OIL SEAL	1	
11	93306-30424	BEARING (B6304A3)	1	
12	4X7-17402-00	DRIVE AXLE ASSY	1	
13	4X7-17221-00	GEAR, 2ND WHEEL (40T)	1	
14	90209-27192	WASHER	1	
15	93440-30077	CIRCLIP	1	
16	42X-17251-00	GEAR ,5TH WHEEL (29T)	1	
17	4X7-17231-00	GEAR, 3RD WHEEL (36T)	1	
18	90209-27192	WASHER	1	
19	93440-30077	CIRCLIP	1	
20	4X7-17241-00	GEAR, 4TH WHEEL (32T)	1	
21	1TA-17211-00	GEAR, 1ST WHEEL (39T)	1	
22	23W-17582-00	GEAR, MIDDLE DRIVE (46T)	1	
23	93306-20421	BEARING (B6204)	1	
24	93306-20550	BEARING (B6205DU8)	1	
25	23W-17583-00	GEAR, MIDDLE DRIVEN (45T)	1	
26	93316-01201	BEARING (B16012)	1	
27	93306-91201	BEARING (B6912)	1	

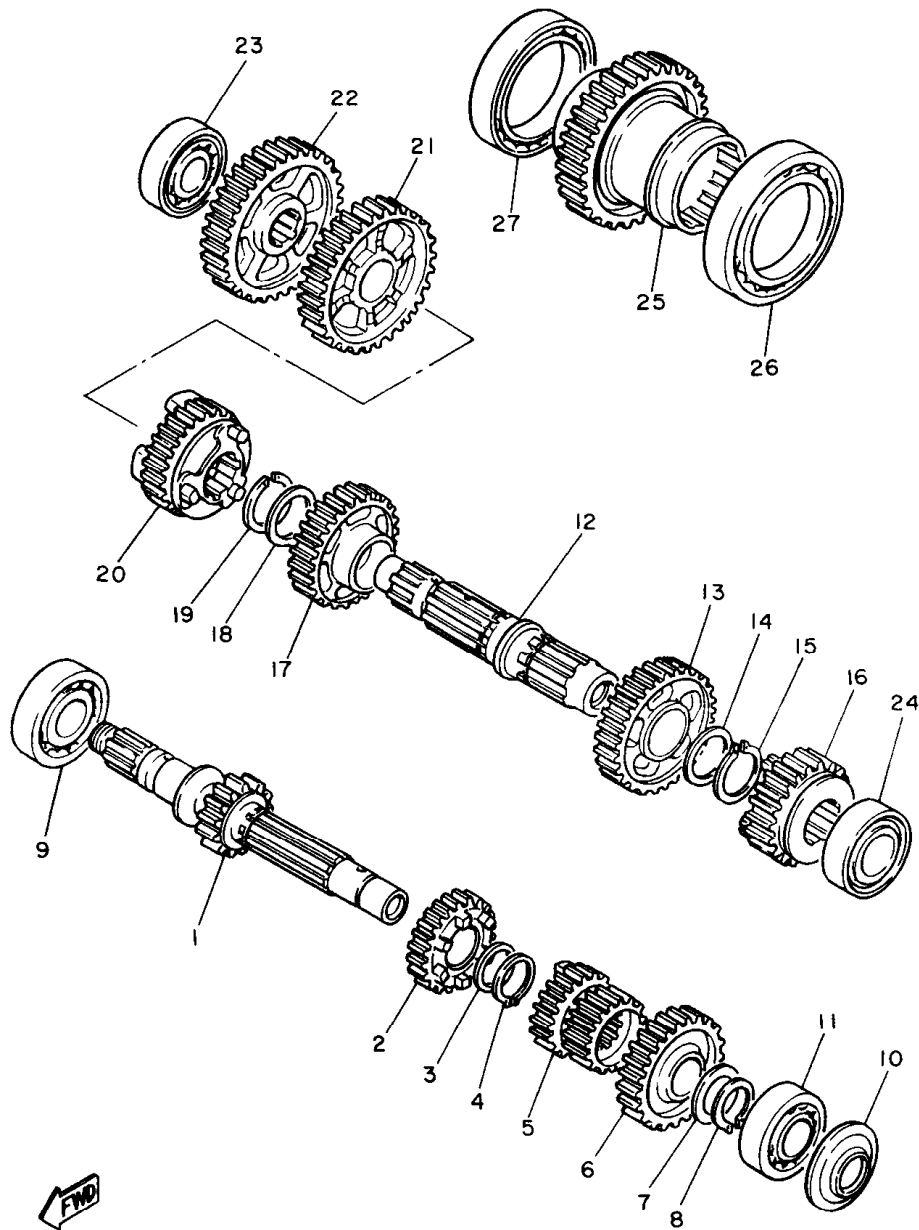

5E3171-1170

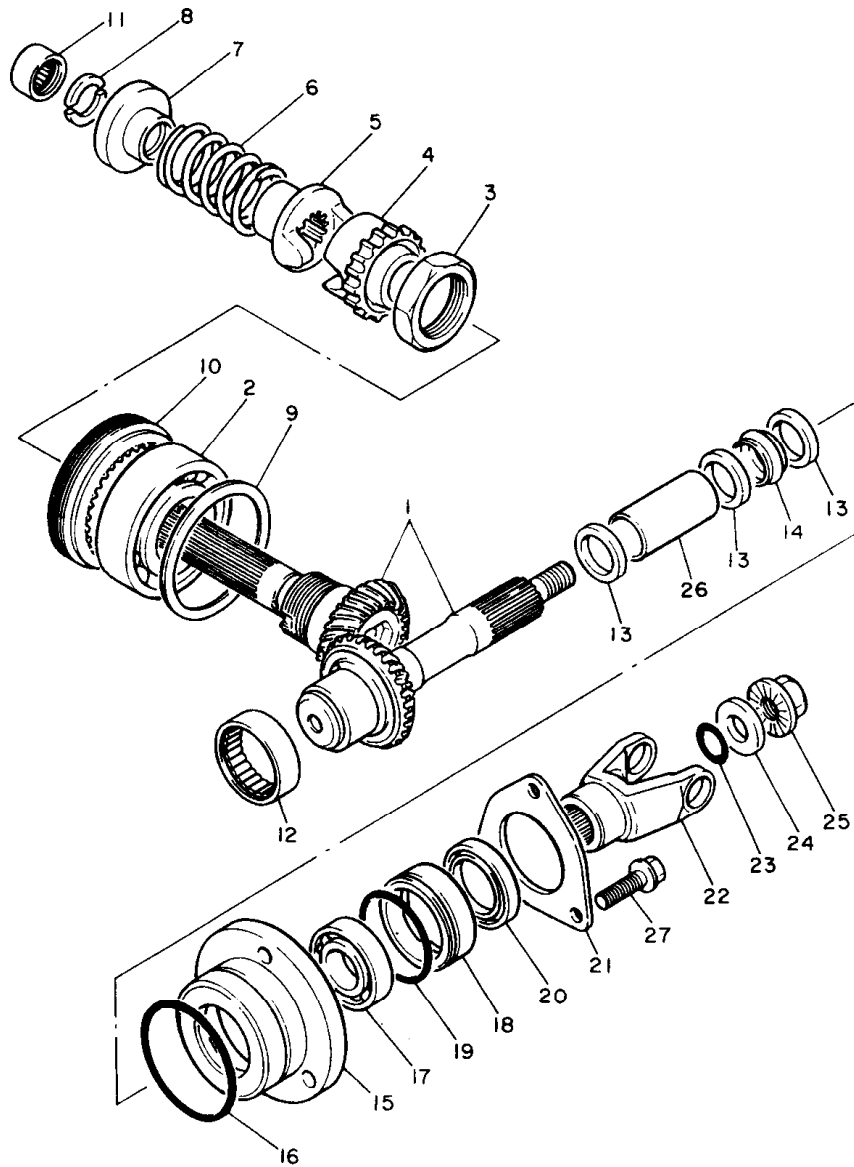



 10L110-2180

FIG. 16 MIDDLE DRIVE GEAR

REF. NO.	PART NO.	DESCRIPTION	Q'TY	REMARKS
1	1TA-Y1757-00	MIDDLE GEAR COMP.	1	
2	93306-20901	BEARING (B6209RSH2-C2)	1	
3	90179-44328	NUT	1	
4	42X-17526-01	CAM, DRIVE	1	
5	31A-17527-00	CAM, DRIVEN	1	
6	90501-70762	SPRING, COMPRESSION	1	
7	4X7-17524-00	HOLDER	1	
8	3H5-17529-00	WASHER, THRUST	2	
9	4X7-17531-00-15	SHIM, PINION (0.15T)	1	UR
	4X7-17531-00-30	SHIM, PINION (0.30T)	1	UR
	4X7-17531-00-50	SHIM, PINION (0.50T)	1	UR
10	90179-88336	NUT	1	
11	93317-22021	BEARING, CYLINDRICAL	1	
12	93311-44051	BEARING, CYLINDRICAL	1	
13	90201-255A6	WASHER, PLATE	3	
14	1J7-46129-Y1	SPACER, EXPANSION	1	
15	11H-17551-00	HOUSING, BEARING	1	
16	93210-71360	O-RING	1	
17	93306-20548	BEARING (B6205RC2)	1	
18	4X7-17554-00	RETAINER, BEARING	1	
19	93210-52449	O-RING	1	
20	93101-35099	OIL SEAL	1	
21	4X7-17558-00	PLATE, BEARING	1	
22	4X7-17556-00	YOKE, JOINT	1	
23	93210-14359	O-RING	1	
24	90201-14633	WASHER, PLATE	1	
25	90179-14317	NUT	1	
26	90387-251E1	COLLAR	1	

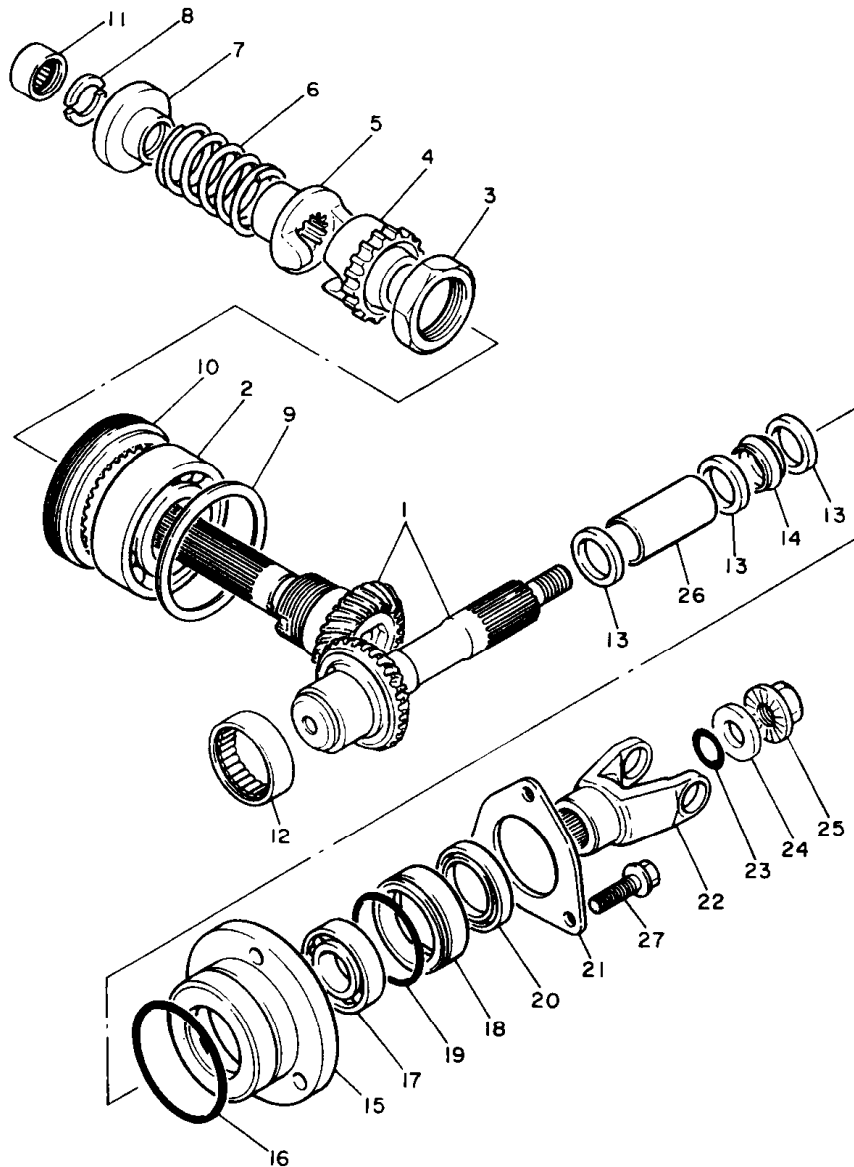
FIG. 16 MIDDLE DRIVE GEAR



REF. NO.	PART NO.	DESCRIPTION	Q'TY	REMARKS
27	95817-08030	BOLT, FLANGE	3	

 10L110-2180

FIG. 17 SHIFT CAM. FORK

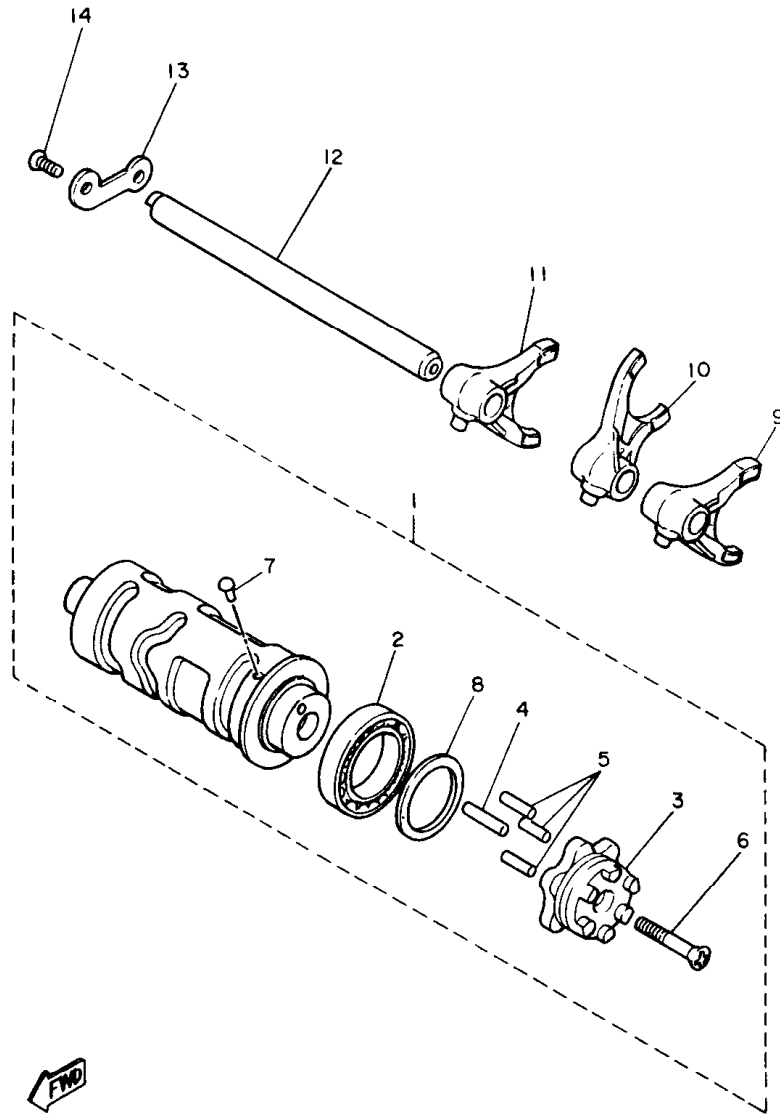

REF. NO.	PART NO.	DESCRIPTION	Q'TY	REMARKS
1	4X7-18540-01	SHIFT CAM ASSY	1	
2	93306-90602	.BEARING	1	
3	4G0-18185-01	.SEGMENT	1	
4	93604-20156	.PIN, DOWEL	1	
5	93604-16092	.PIN, DOWEL	3	
6	98701-05035	.SCREW, FLAT HEAD	1	
7	136-18542-00	.POINT, NEUTRAL	1	
8	90201-30297	.WASHER, PLATE	1	
9	4X7-18511-00	FORK, SHIFT 1	1	
10	4X7-18512-00	FORK, SHIFT 2	1	
11	4X7-18513-00	FORK, SHIFT 3	1	
12	4X7-18531-00	BAR, SHIFT FORK GUIDE 1	1	
13	4X7-18536-00	STOPPER, SHIFT BAR	1	
14	98707-06016	SCREW, FLAT HEAD	2	

FWD
5E3171-1190

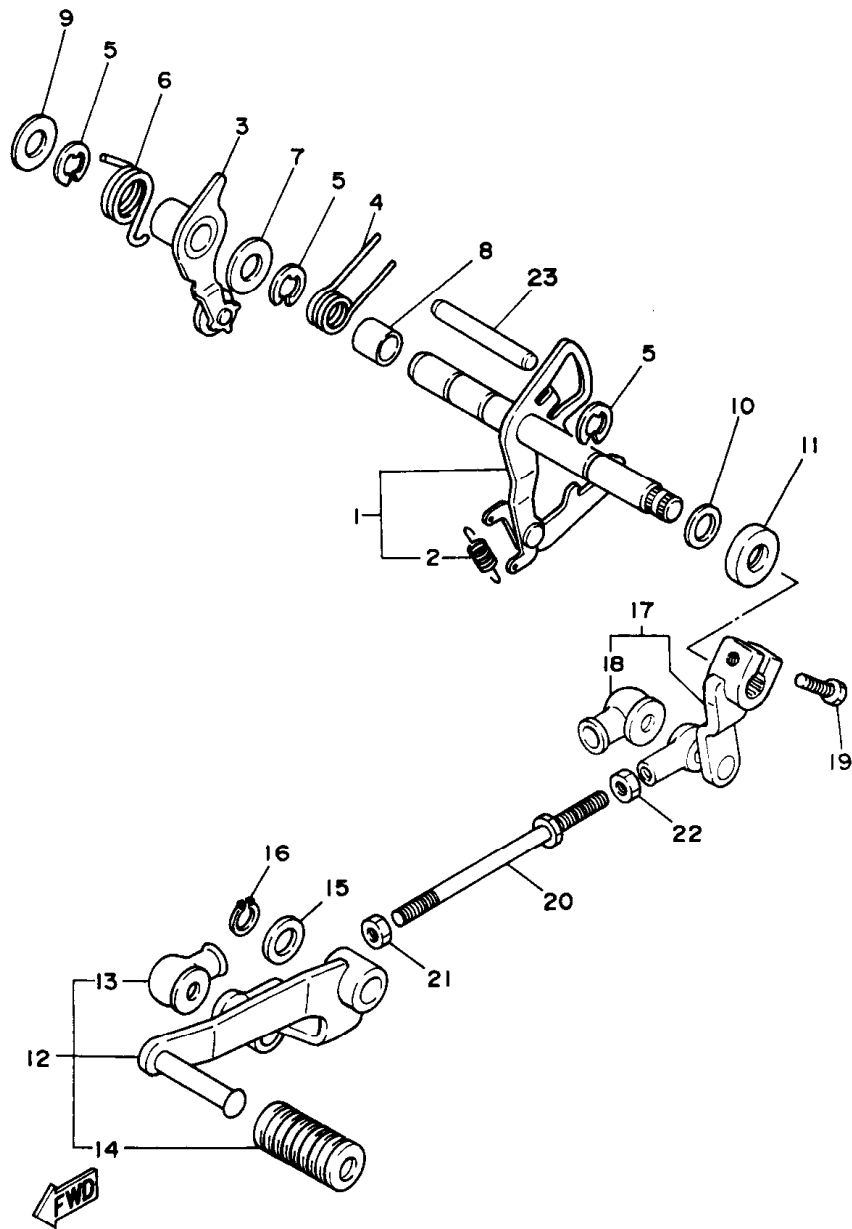

FIG. 18 SHIFT SHAFT

REF. NO.	PART NO.	DESCRIPTION	Q'TY	REMARKS
1	4X7-18120-01	SHIFT LEVER ASSY	1	
2	90506-08227	.SPRING, TENSION	1	
3	4X7-18140-00	STOPPER LEVER ASSY	1	
4	90508-32535	SPRING, TORSION	1	
5	99006-10600	CIRCLIP	3	
6	90508-29531	SPRING, TORSION	1	
7	90201-12588	WASHER, PLATE	1	
8	90387-124F4	COLLAR	1	
9	90201-12588	WASHER, PLATE	1	
10	90201-12166	WASHER, PLATE	1	
11	93102-12106	OIL SEAL	1	
12	42X-18110-01	SHIFT PEDAL ASSY	1	
13	2H9-18154-00	.COVER, DUST	1	
14	132-18113-01	.COVER, SHIFT PEDAL	1	
15	90201-124E4	WASHER, PLATE	1	
16	99009-12400	CIRCLIP	1	
17	42X-18112-01	ARM, SHIFT	1	
18	2H9-18154-00	.COVER, DUST	1	
19	97024-06020	BOLT	1	
20	29L-18115-00	ROD, SHIFT	1	
21	90170-06228	NUT (COUNTER CLOCKWISE)	1	
22	95304-06700	NUT	1	
23	93608-50158	PIN, DOWEL	1	

3EF2361-9180

FIG. 19 FRAME

REF. NO.	PART NO.	DESCRIPTION	Q'TY	REMARKS
1	3LP-21110-00-33	FRAME COMP.	1	YAMAHA BLACK
2	42X-21317-00	STAY, ENGINE 3	1	
3	42X-21359-00	BRACKET, COIL	1	
4	98517-06012	SCREW, PAN HEAD	1	
5	92907-06100	WASHER, SPRING	1	
6	92907-06600	WASHER, PLATE	1	
7	90105-10297	BOLT, WASHER BASED	2	
8	90176-10075	NUT, CROWN	2	
9	90179-12248	NUT	4	
10	90201-125A3	WASHER, PLATE	4	
11	42X-21315-01	STAY, ENGINE 2	1	
12	42X-21316-01	STAY, ENGINE 3	1	
13	90105-10298	BOLT, WASHER BASED	2	
14	90201-105H3	WASHER, PLATE	2	
15	90387-100E2	COLLAR	2	
16	4X7-21485-00	DAMPER, RUBBER 1	2	
17	90105-10050	BOLT, WASHER BASED	2	
18	90105-10300	BOLT, WASHER BASED	1	
19	42X-21458-01	BRACKET, SIDE STAND	1	
20	90176-10075	NUT, CROWN	2	
21	90105-06069	BOLT, WASHER BASED	1	
22	90202-05187	WASHER, PLATE	1	
23	90338-07043	PLUG	2	
24	90462-08138	CLAMP	2	
25	97707-50508	SCREW, TAPPING	2	
26	2AE-2139R-00	COVER 2	1	
27	90159-06058	SCREW, WITH WASHER	1	
28	*	STEERING LOCK ASSY	1	LM

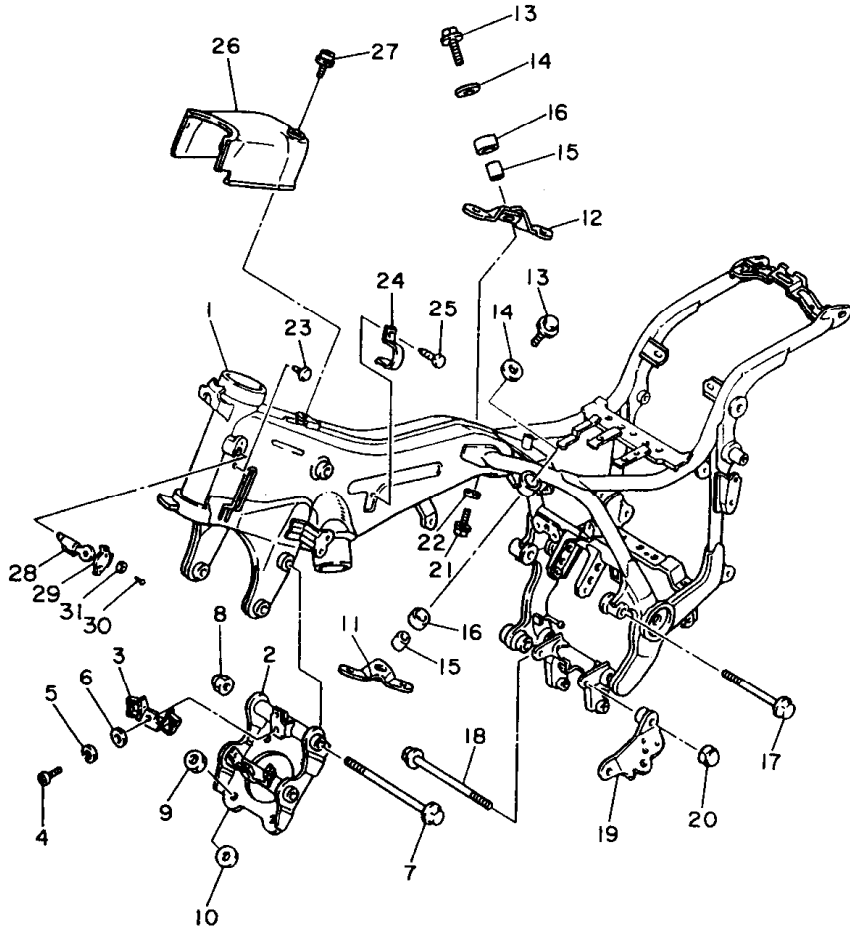

3LP7332-4190

C14

FIG. 19 FRAME

REF. NO.	PART NO.	DESCRIPTION	Q'TY	REMARKS
29	134-23484-10	CAP, HANDLE LOCK	1	
30	90269-04003	RIVET	1	
31	90208-04029	WASHER, CONICAL SPRING	1	

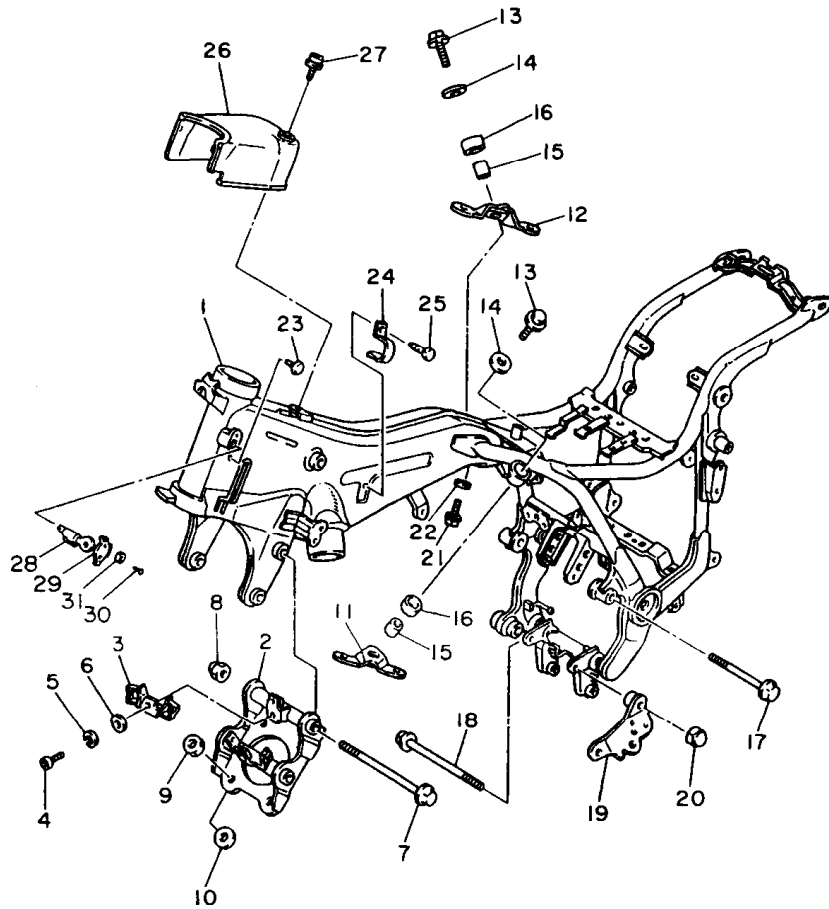

3LP7332-4190

C15

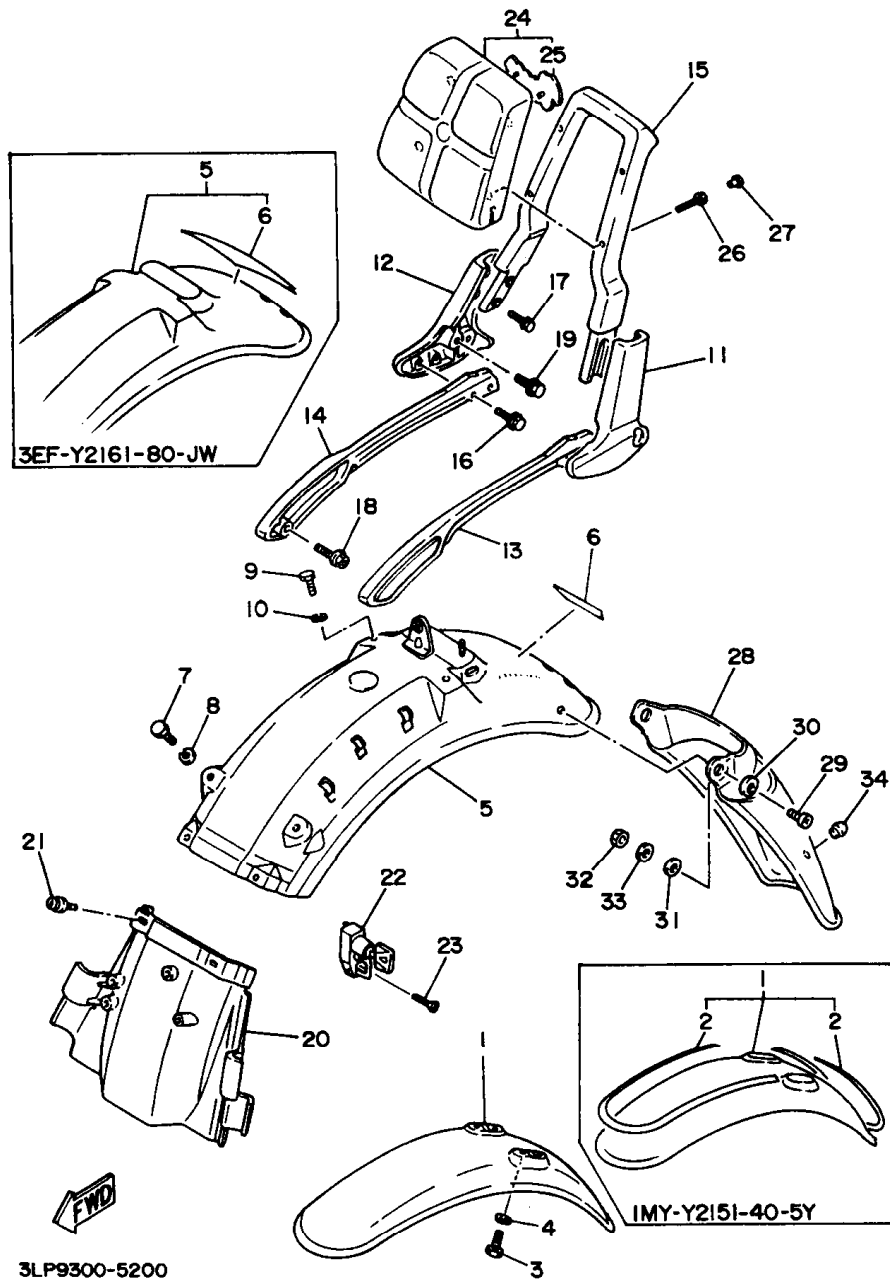

FIG. 20 FENDER

REF. NO.	PART NO.	DESCRIPTION	Q'TY	REMARKS
1	1MY-21510-00-P2	FRONT FENDER COMP.	1	UR VERY DARK MAGENTA COCKTAIL 1
	1MY-Y2151-40-5Y	FRONT FENDER COMP.	1	UR URUSHI BLACK/ GRACEFUL MAROON
2	4PW-21570-00	.GRAPHIC SET, FRONT FENDER	1	FOR URB
3	97027-06012	BOLT	4	
4	92907-06100	WASHER	4	
5	3EF-21610-00-P0	REAR FENDER COMP.	1	UR VERY DARK MAGENTA COCKTAIL 1
	3EF-Y2161-80-JW	REAR FENDER COMP.	1	UR URUSHI BLACK
6	99236-00080	EMBLEM, YAMAHA	1	UR FOR VDMCT
	4PW-21675-00	.GRAPHIC, REAR FENDER	1	UR FOR URB
7	97027-06012	BOLT	2	
8	92907-06100	WASHER	2	
9	97027-08012	BOLT	2	
10	92907-08100	WASHER	2	
11	1RM-2164F-00	STAY 1	1	
12	1RM-2164G-00	STAY 2	1	
13	3JK-2164H-00	STAY 3	1	
14	3JK-2164J-00	STAY 4	1	
15	42H-2164A-02	GRIP 1	1	
16	95817-06016	BOLT, FLANGE	4	
17	95827-06016	BOLT, FLANGE	4	
18	90149-08225	SCREW	2	
19	90105-10217	BOLT, WASHER BASED	2	
20	42X-21629-00	GUARD, MUD	1	
21	90159-06128	SCREW, WITH WASHER	2	
22	26H-21308-00	HELMET HANGER ASSY	1	
23	90149-06154	SCREW	1	
24	1TA-2840F-00	BACK REST ASSY	1	
25	42H-24786-00	.EMBLEM	1	

D2

FIG. 20 FENDER

REF. NO.	PART NO.	DESCRIPTION	Q'TY	REMARKS
26	91317-06035	BOLT	4	
27	90338-06162	PLUG	4	
28	3EF-21621-00	FLAP	1	
29	98517-06012	SCREW, PAN HEAD	2	
30	92907-06600	WASHER	2	
31	90202-05187	WASHER, PLATE	2	
32	95317-06600	NUT	2	
33	92907-06200	WASHER	2	
34	460-21639-00	DAMPER 2	1	

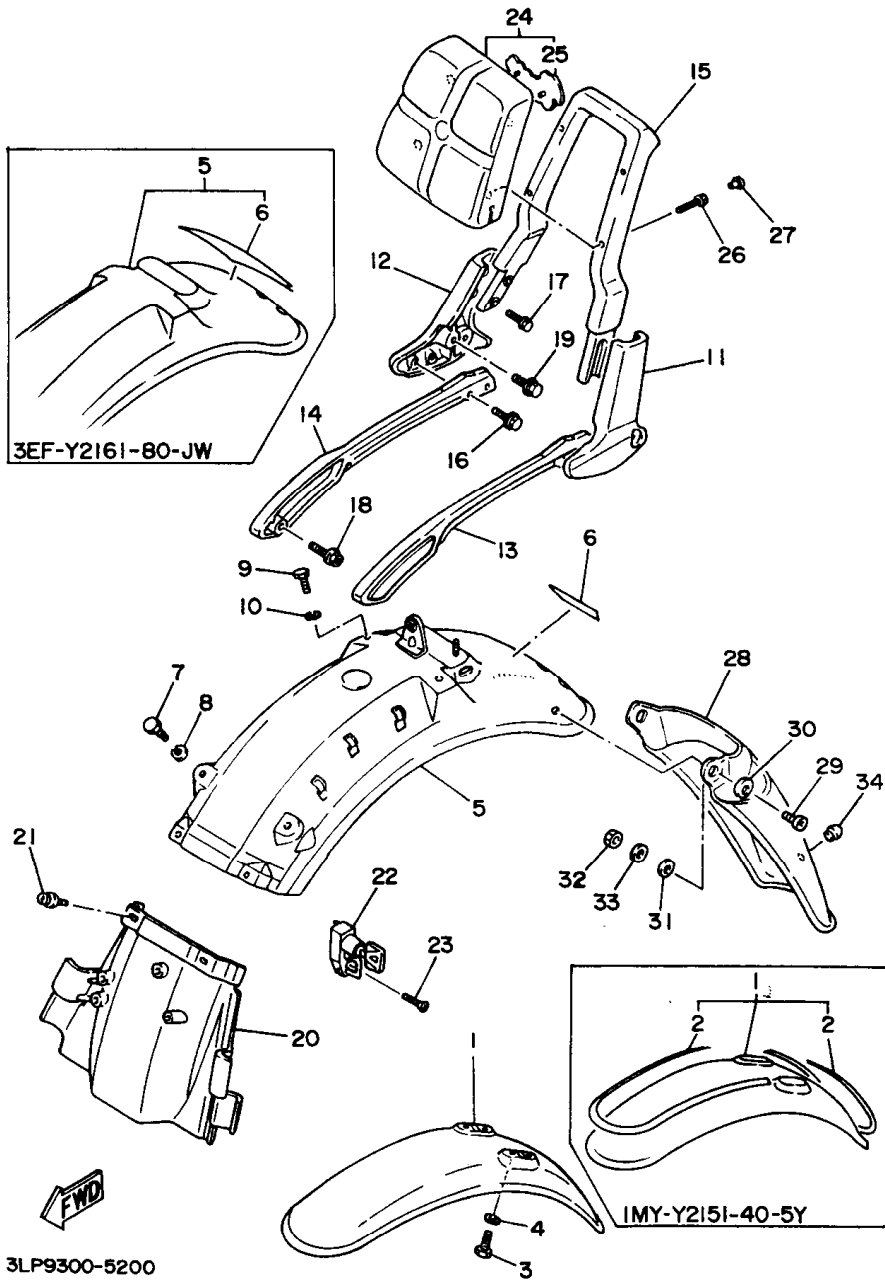

D3

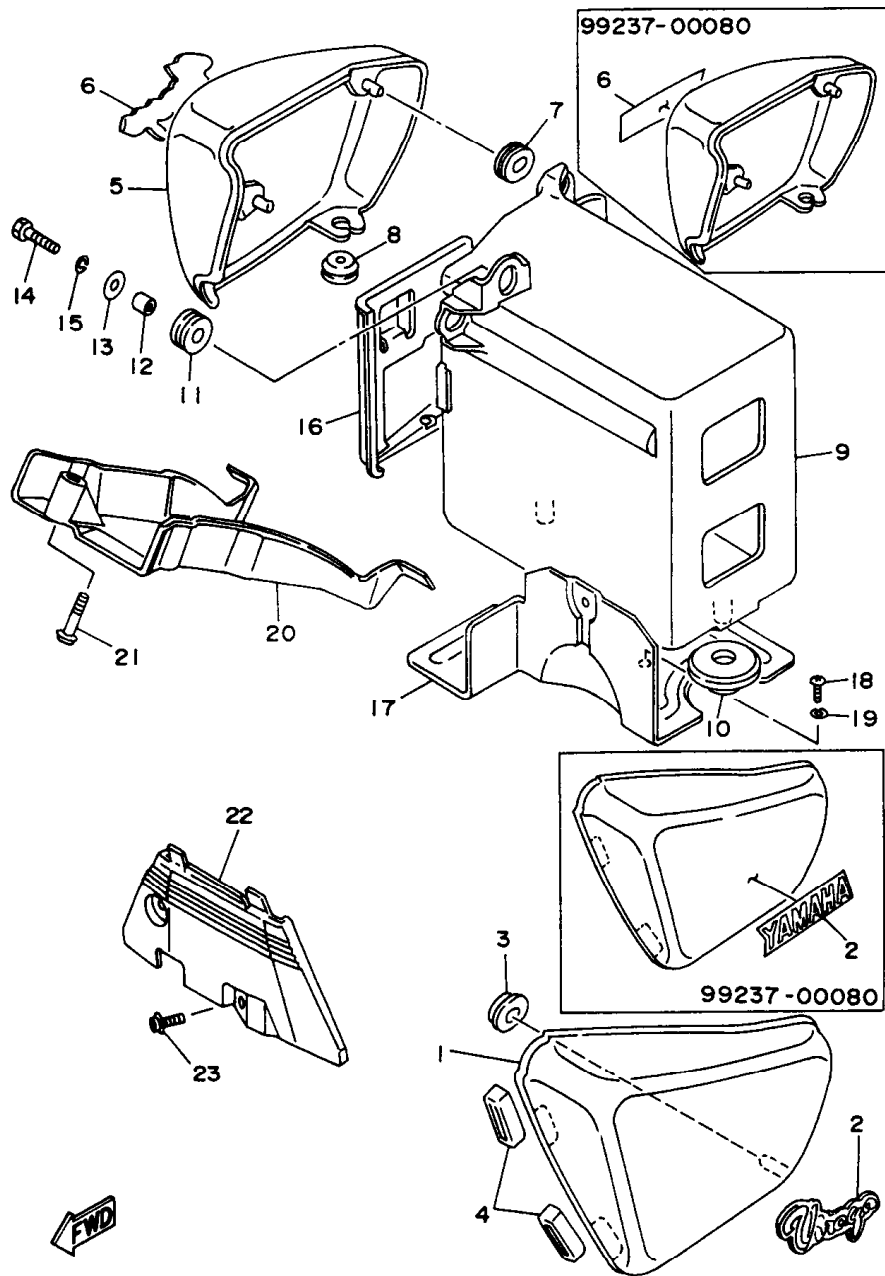

FIG. 21 SIDE COVER

REF. NO.	PART NO.	DESCRIPTION	Q'TY	REMARKS
1	42X-21711-00-P2	COVER, SIDE 1	1	UR VERY DARK MAGENTA COCKTAIL 1
	42X-21711-00-JW	COVER, SIDE 1	1	UR URUSHI BLACK
2	42X-21781-00	EMBLEM 1	1	UR FOR VDMCT
	99237-00080	EMBLEM, YAMAHA	1	UR FOR URB
3	90480-01401	GROMMET	1	
4	466-21717-00	DAMPER, SIDE COVER	2	
5	42X-21721-00-P2	COVER, SIDE 2	1	UR VERY DARK MAGENTA COCKTAIL 1
	42X-21721-00-JW	COVER, SIDE 2	1	UR URUSHI BLACK
6	42X-21782-00	EMBLEM 2	1	UR FOR VDMCT
	99237-00080	EMBLEM, YAMAHA	1	UR FOR URB
7	90480-01401	GROMMET	2	
8	90480-12053	GROMMET	1	
9	42X-21171-00	BOX	1	
10	90480-20384	GROMMET	2	
11	90480-16233	GROMMET	1	
12	90387-060A7	COLLAR	1	
13	90201-06067	WASHER, PLATE	1	
14	97007-06020	BOLT	1	
15	92907-06100	WASHER	1	
16	42X-28185-00	LID	1	
17	42X-2172W-02	COVER	1	
18	98507-06010	SCREW, PAN HEAD	2	
19	92907-06100	WASHER, SPRING	2	
20	42X-2176E-00	PLATE	1	
21	90159-06110	SCREW, WITH WASHER	1	
22	42X-2117F-00	COVER	1	
23	90159-06071	SCREW, WITH WASHER	2	

3LP9332-5210

D4

FIG. 22 REAR ARM. SUSPENSION

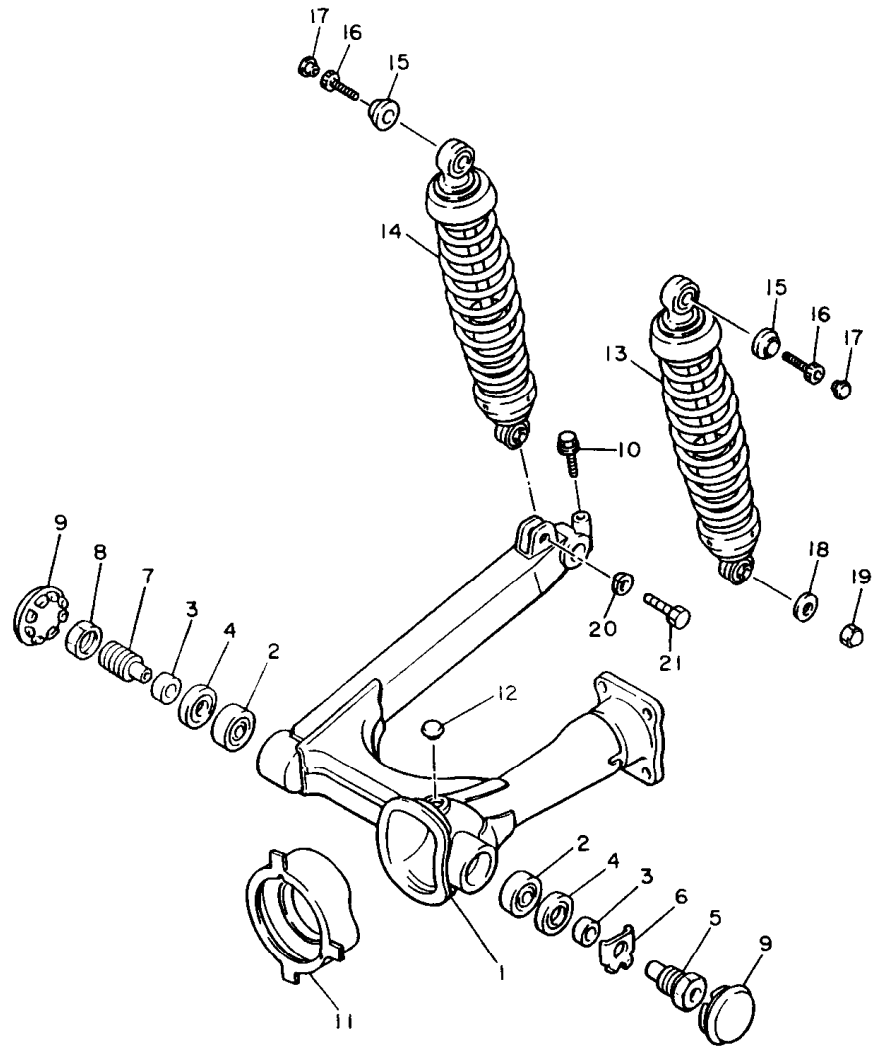

REF. NO.	PART NO.	DESCRIPTION	QTY	REMARKS
1	1RM-22110-00-35	REAR ARM COMP.	1	SILVER
2	93332-00010	BEARING	2	
3	90387-17543	COLLAR	2	
4	93102-25017	OIL SEAL	2	
5	42X-22141-00	SHAFT, PIVOT	1	
6	90215-22238	WASHER, LOCK	1	
7	1J7-22141-00	SHAFT, PIVOT	1	
8	1J7-22143-00	NUT	1	
9	2H7-2219X-00	COVER	2	
10	95024-08035	BOLT, FLANGE	1	
11	4X7-22189-01	BOOT, RUBBER	1	
12	90338-20113	PLUG	1	
13	3JK-22210-01	SHOCK ABSORBER ASSY, REAR	1	
14	3JK-22220-01	SHOCK ABSORBER ASSY, REAR	1	
15	57A-22243-01	WASHER 1	2	
16	91317-08020	BOLT	2	
17	90338-08163	PLUG	2	
18	90201-105R9	WASHER, PLATE	1	
19	90176-10073	NUT, CROWN	1	
20	92990-10100	WASHER, SPRING	1	
21	90106-10052	BOLT	1	



3CF110-8220

D5

FIG. 23 DRIVE SHAFT

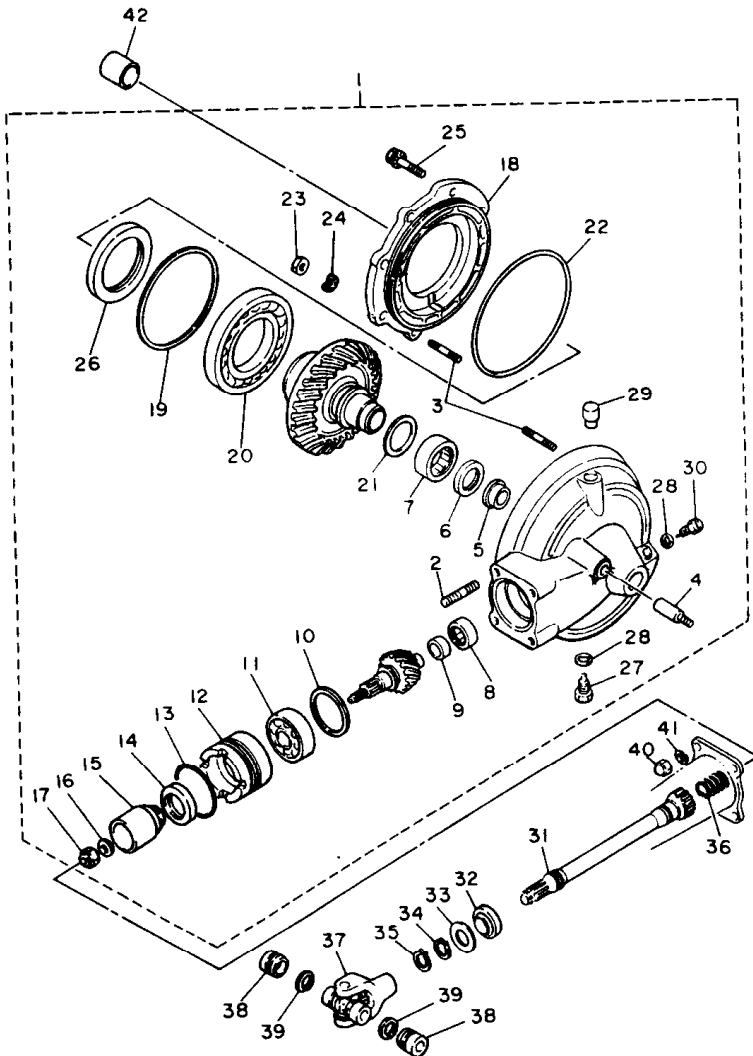

REF. NO.	PART NO.	DESCRIPTION	Q'TY	REMARKS
1	56W-46101-02	REAR AXLE GEAR CASE ASSY	1	
2	90116-10361	.BOLT, STUD	4	
3	90116-08360	.BOLT, STUD	6	
4	90116-10249	.BOLT, STUD	1	
5	4H7-46153-00	.COLLAR, GUIDE	1	
6	93101-30084	.OIL SEAL	1	
7	93311-43729	.BEARING, CYLINDRICAL	1	
8	93317-41510	.BEARING, CYLINDRICAL	1	
9	2H7-46122-00	.RACE, INNER	1	
10	1J7-17537-Y0-30	.SHIM, THRUST (0.30T)	1	UR
	1J7-17537-Y0-40	.SHIM, THRUST (0.40T)	1	UR
	1J7-17537-Y0-50	.SHIM, THRUST (0.50T)	1	UR
11	93306-30533	.BEARING (B6305RB1 SPECIAL)	1	
12	4H7-46125-00	.RETAINER, BEARING	1	
13	93210-60426	.O-RING	1	
14	93101-38098	.OIL SEAL	1	
15	4H7-46123-01	.COUPLING, GEAR	1	
16	90201-14632	.WASHER, PLATE	1	
17	90185-14070	.NUT, SELF-LOCKING	1	
18	4H7-46152-00	.HOUSING, BEARING	1	
19	1J7-46117-Y0-30	.SHIM, RING GEAR (0.30T)	1	UR
	1J7-46117-Y0-40	.SHIM, RING GEAR (0.40T)	1	UR
	1J7-46117-Y0-50	.SHIM, RING GEAR (0.50T)	1	UR
20	93316-01403	.BEARING, CYLINDRICAL	1	
21	22U-46118-00-12	.SHIM, THRUST (1.2T)	1	UR
	22U-46118-00-14	.SHIM, THRUST (1.4T)	1	UR
	22U-46118-00-16	.SHIM, THRUST (1.6T)	1	UR
	22U-46118-00-18	.SHIM, THRUST (1.8T)	1	UR

FWD
1TE110-6230

D6

FIG. 23 DRIVE SHAFT

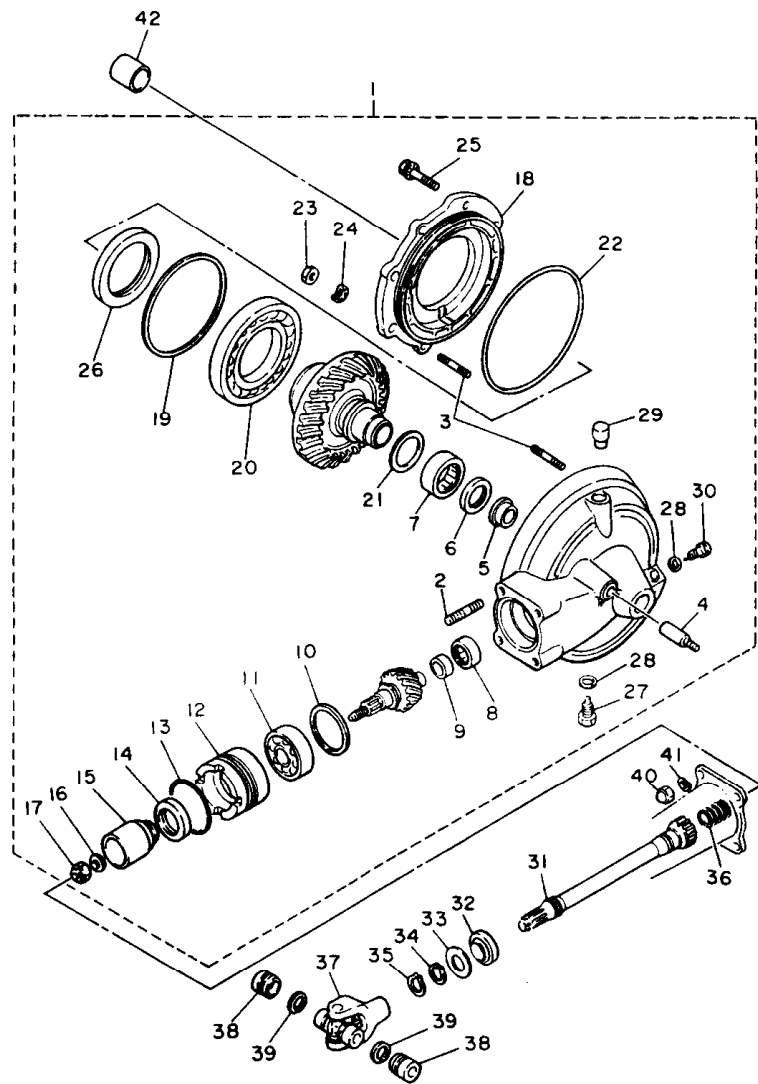

REF. NO.	PART NO.	DESCRIPTION	Q'TY	REMARKS
21	22U-46118-00-20	.SHIM, THRUST (2.0T)	1	UR
22	93211-44348	.O-RING	1	
23	95333-08600	.NUT	6	
24	92901-08700	.WASHER, WAVE	6	
25	95811-10025	.BOLT, FLANGE	2	
26	93102-70167	.OIL SEAL	1	
27	90340-14130	.PLUG, STRAIGHT SCREW	1	
28	214-11198-01	.GASKET	2	
29	56W-17590-00	.BREATHER COMP.	1	
30	90340-14118	.PLUG, STRAIGHT SCREW	1	
31	4X7-46172-00	SHAFT, DRIVE	1	
32	93108-23007	OIL SEAL	1	
33	90201-231A2	WASHER, PLATE	1	
34	93410-23056	CIRCLIP	1	
35	93410-22039	CIRCLIP	1	
36	90501-16491	SPRING, COMPRESSION	1	
37	4X7-46180-00	CROSS JOINT COMP.	1	
38	93399-99926	BEARING	2	
39	93440-20088	CIRCLIP	2	
40	90176-10075	NUT, CROWN	4	
41	92990-10100	WASHER, SPRING	4	
42	90387-172A5	COLLAR	1	



1TE110-6230

D7

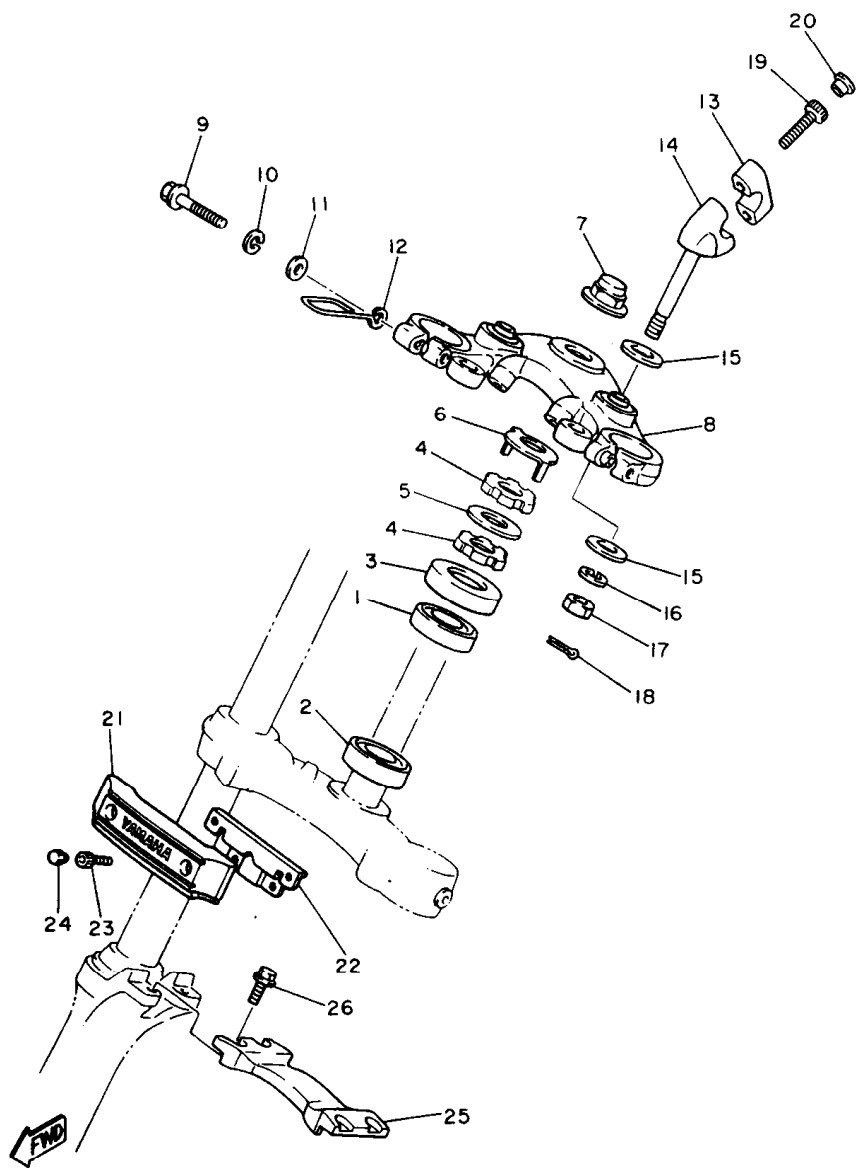

1RR110-6240

FIG. 24 STEERING

REF. NO.	PART NO.	DESCRIPTION	Q'TY	REMARKS
1	93332-00001	BEARING	1	
2	93332-00008	BEARING	1	
3	1J7-23415-00	COVER, BALL RACE 1	1	
4	90179-25033	NUT	2	
5	90202-26142	WASHER, PLATE	1	
6	26H-23418-01	WASHER, SPECIAL	1	
7	90176-22050	NUT, CROWN	1	
8	42X-W2341-01-38	CROWN, HANDLE	1	CLEAR (WITH BUFF)
9	95024-08045	BOLT, FLANGE	2	
10	92990-08100	WASHER, SPRING	2	
11	92990-08600	WASHER, PLATE	2	
12	1UF-23317-01	HOLDER, CABLE	2	
13	4H7-23441-00-38	HOLDER, HANDLE UPPER	2	CLEAR (WITH BUFF)
14	42X-23442-00-38	HOLDER, HANDLE LOWER	2	CLEAR (WITH BUFF)
15	90201-100A1	WASHER, PLATE	4	
16	92907-10100	WASHER, SPRING	2	
17	95307-10700	NUT	2	
18	90468-12006	CLIP	2	
19	91314-08030	BOLT	4	
20	90338-08163	PLUG	4	
21	1RM-23122-00	COVER, OUTER 1	1	
22	1RM-2317E-00	STAY	1	
23	92014-06012	BOLT, BUTTON HEAD	2	
24	90338-08163	PLUG	4	
25	42X-2313A-00	BRACE, FORK	1	
26	95024-08020	BOLT, FLANGE	4	

FIG. 25 FRONT FORK

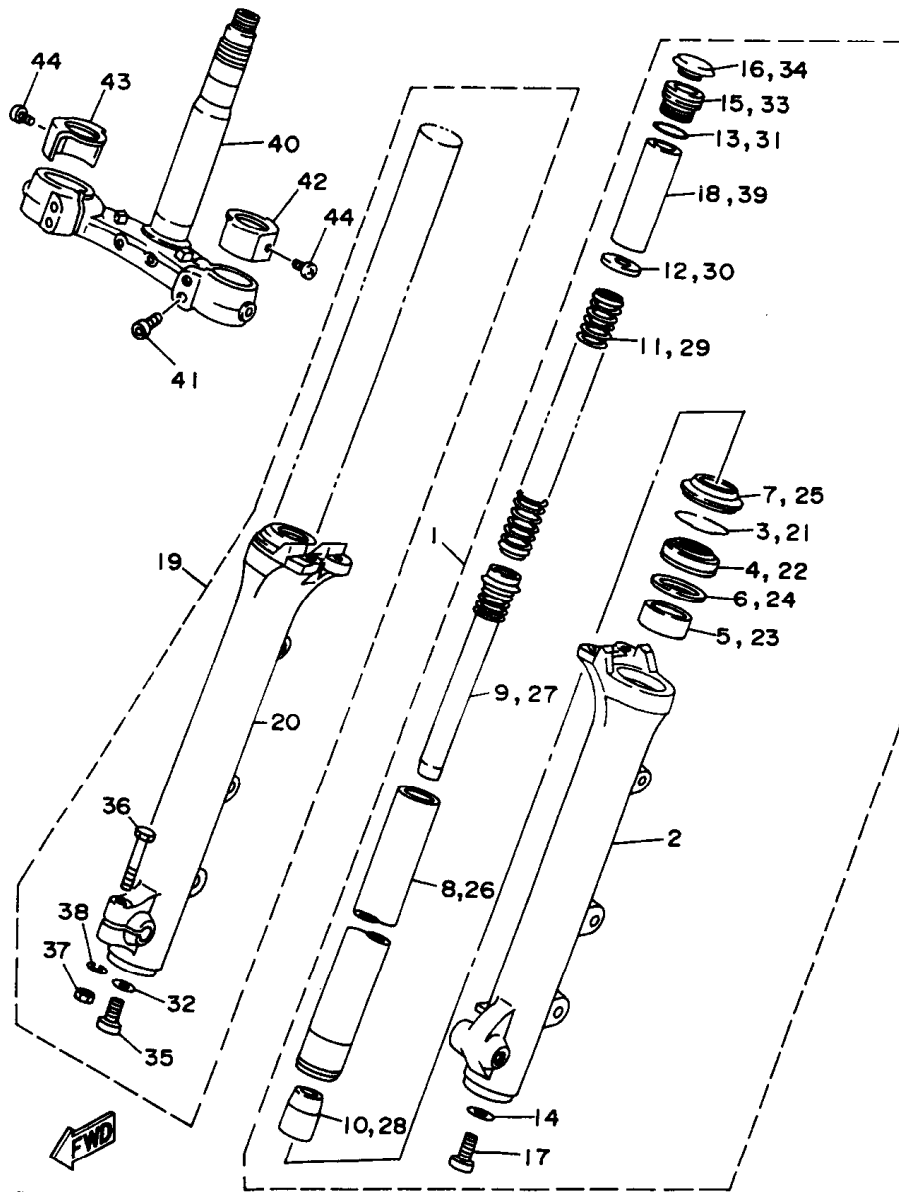

3LP9332-5250

REF. NO.	PART NO.	DESCRIPTION	Q'TY	REMARKS
1	3LP-23102-30	FRONT FORK ASSY (L.H)	1	UR
	3JK-23102-10	FRONT FORK ASSY (L.H)	1	UR FOR AUSTRIA
2	3LP-23126-30	.TUBE, OUTER (LEFT)	1	UR
	3JK-23126-10	.TUBE, OUTER (LEFT)	1	UR FOR AUSTRIA
3	3R4-23153-00	.RING, SNAP	1	
4	3EN-23145-00	.OIL SEAL	1	
5	2YK-23125-00	.METAL, SLIDE 1	1	
6	4V2-23146-L0	.WASHER, OIL SEAL	1	
7	3EN-23144-00	.SEAL, DUST	1	
8	1RM-23110-00	.INNER TUBE COMP. 1	1	
9	33M-23170-00	.CYLINDER COMP., FRONT FORK	1	UR
	42H-23170-00	.CYLINDER COMP., FRONT FORK	1	UR FOR AUSTRIA
10	1W1-23173-L0	.SPINDLE, TAPER	1	UR
	11H-23173-00	.SPINDLE, TAPER	1	UR FOR AUSTRIA
11	42H-23141-00	.SPRING, FRONT FORK	1	
12	4FY-23149-00	.WASHER, SPRING UPPER	1	
13	1W1-23114-L0	.GASKET	1	
14	509-23158-L0	.GASKET	1	
15	31A-23111-31	.BOLT, CAP	1	
16	42H-23168-00	.CAP, FRONT FORK	1	
17	278-23181-50	.BOLT, HEXAGON SOCKET HEAD	1	
18	42X-23118-00	.SPACER	1	
19	3LP-23103-30	FRONT FORK ASSY (R.H)	1	UR
	3JK-23103-10	FRONT FORK ASSY (R.H)	1	UR FOR AUSTRIA
20	3LP-23136-30	.TUBE, OUTER (RIGHT)	1	UR
	3JK-23136-10	.TUBE, OUTER (RIGHT)	1	UR FOR AUSTRIA
21	3R4-23153-00	.RING, SNAP	1	
22	3EN-23145-00	.OIL SEAL	1	

D9

FIG. 25 FRONT FORK

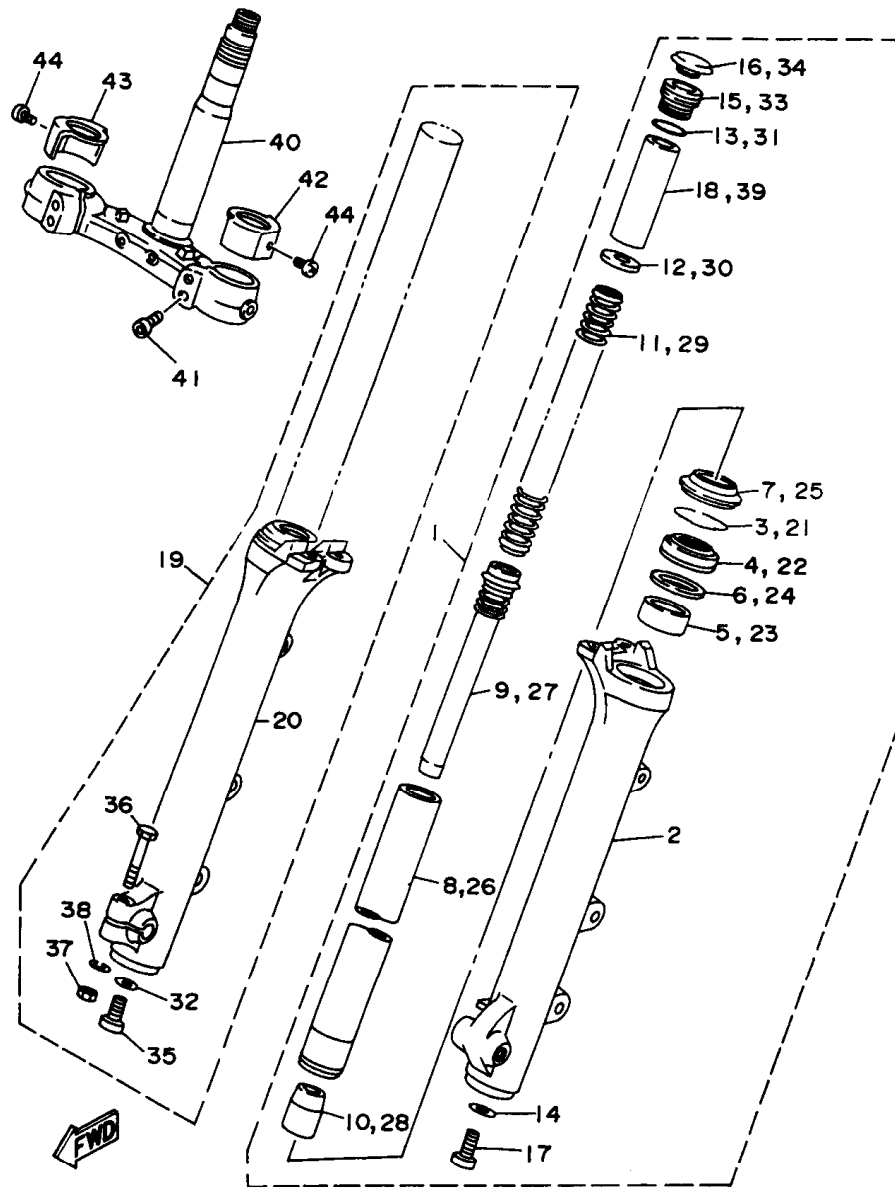

3LP9332-5250

REF. NO.	PART NO.	DESCRIPTION	Q'TY	REMARKS
23	2YK-23125-00	.METAL, SLIDE 1	1	
24	4V2-23146-L0	.WASHER, OIL SEAL	1	
25	3EN-23144-00	.SEAL, DUST	1	
26	1RM-23110-00	.INNER TUBE COMP. 1	1	
27	33M-23170-00	.CYLINDER COMP., FRONT FORK	1	UR
	42H-23170-00	.CYLINDER COMP., FRONT FORK	1	UR FOR AUSTRIA
28	1W1-23173-L0	.SPINDLE, TAPER	1	UR
	11H-23173-00	.SPINDLE, TAPER	1	UR FOR AUSTRIA
29	42H-23141-00	.SPRING, FRONT FORK	1	
30	4FY-23149-00	.WASHER, SPRING UPPER	1	
31	1W1-23114-L0	.GASKET	1	
32	509-23158-L0	.GASKET	1	
33	31A-23111-31	.BOLT, CAP	1	
34	42H-23168-00	.CAP, FRONT FORK	1	
35	278-23181-50	.BOLT, HEXAGON SOCKET HEAD	1	
36	97313-08045	.BOLT	1	
37	95333-08600	.NUT	1	
38	92990-08100	.WASHER, SPRING	1	
39	42X-23118-00	.SPACER	1	
40	2AE-23340-30	UNDER BRACKET COMP.	1	
41	91311-08030	BOLT	4	
42	1RM-23132-00	COVER (L.H)	1	
43	1RM-23132-10	COVER (R.H)	1	
44	98580-05006	SCREW, PAN HEAD	2	

FIG. 26 FUEL TANK

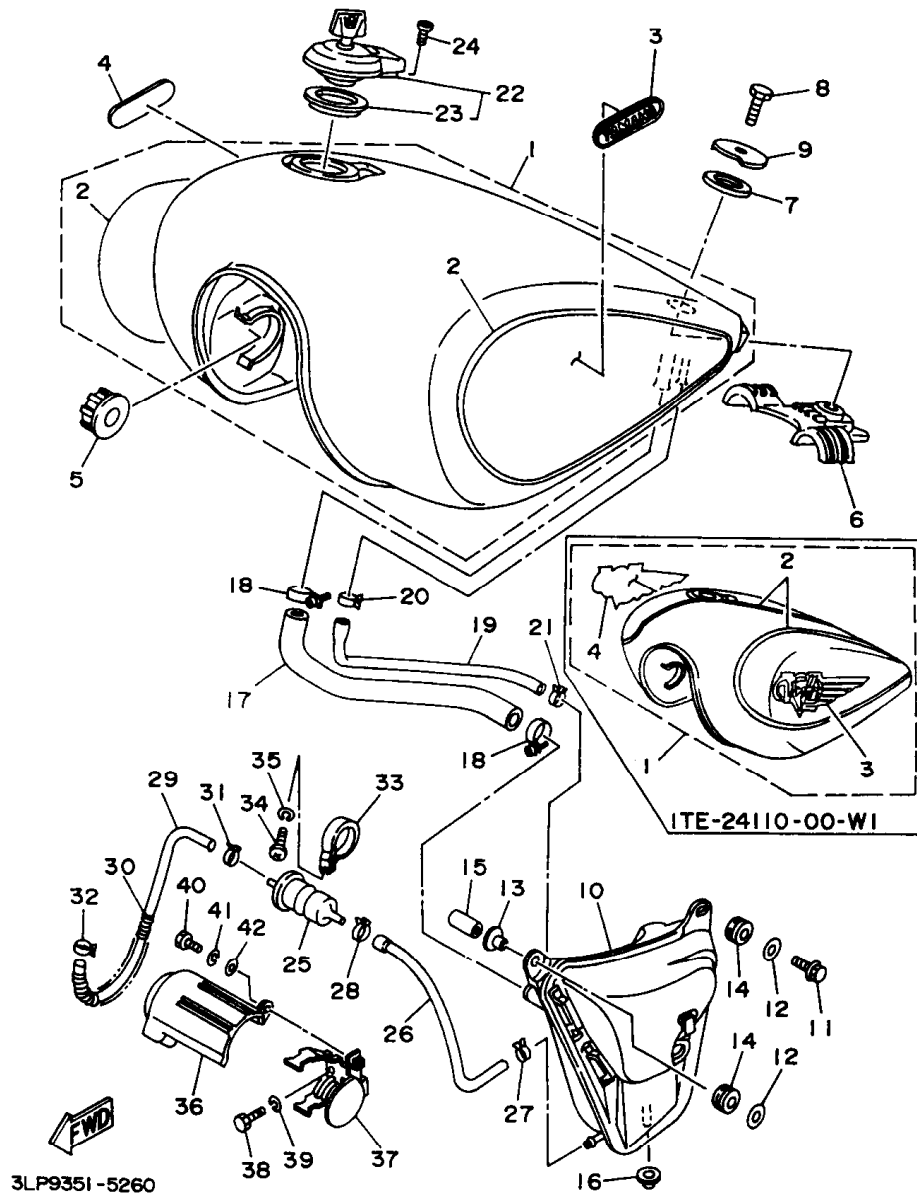

3LP9351-5260

REF. NO.	PART NO.	DESCRIPTION	Q'TY	REMARKS
1	1TE-24110-00-X3	FUEL TANK COMP.	1	UR VERY DARK MAGENTA COCKTAIL 1
	1TE-24110-00-W1	FUEL TANK COMP.	1	UR URUSHI BLACK/ GRACEFUL MAROON
2	3JK-24240-50	.GRAPHIC SET	1	UR FOR VDMC1
	4PW-24240-00	.GRAPHIC SET	1	UR FOR URB
3	1RM-24161-10	EMBLEM 1	1	UR FOR VDMC1
	4PW-24161-00	.EMBLEM 1	1	UR FOR URB
4	1RM-24162-10	EMBLEM 2	1	UR FOR VDMC1
	4PW-24162-00	.EMBLEM 2	1	UR FOR URB
5	4H7-24181-00	DAMPER, LOCATING 1	2	
6	42X-24182-00	DAMPER, LOCATING 2	1	
7	42X-24183-00	DAMPER, LOCATING 3	1	
8	97007-08016	BOLT	1	
9	42X-24186-00	WASHER, SPECIAL	1	
10	42H-24280-00	SUB TANK ASSY	1	
11	91317-06020	BOLT	1	
12	90201-06059	WASHER, PLATE	2	
13	90387-062L2	COLLAR	1	
14	90480-13163	GROMMET	2	
15	90560-06258	SPACER	1	
16	90480-10408	GROMMET	1	
17	42H-24316-00	PIPE 6	1	
18	90460-16192	CLAMP, HOSE	2	
19	42H-24317-00	PIPE 7	1	
20	90467-11044	CLIP	1	
21	90467-10135	CLIP	1	
22	4X7-24602-04	CAP ASSY	1	
23	4X7-24612-00	.GASKET, CAP	1	
24	91317-05010	BOLT	1	

D11

FIG. 26 FUEL TANK

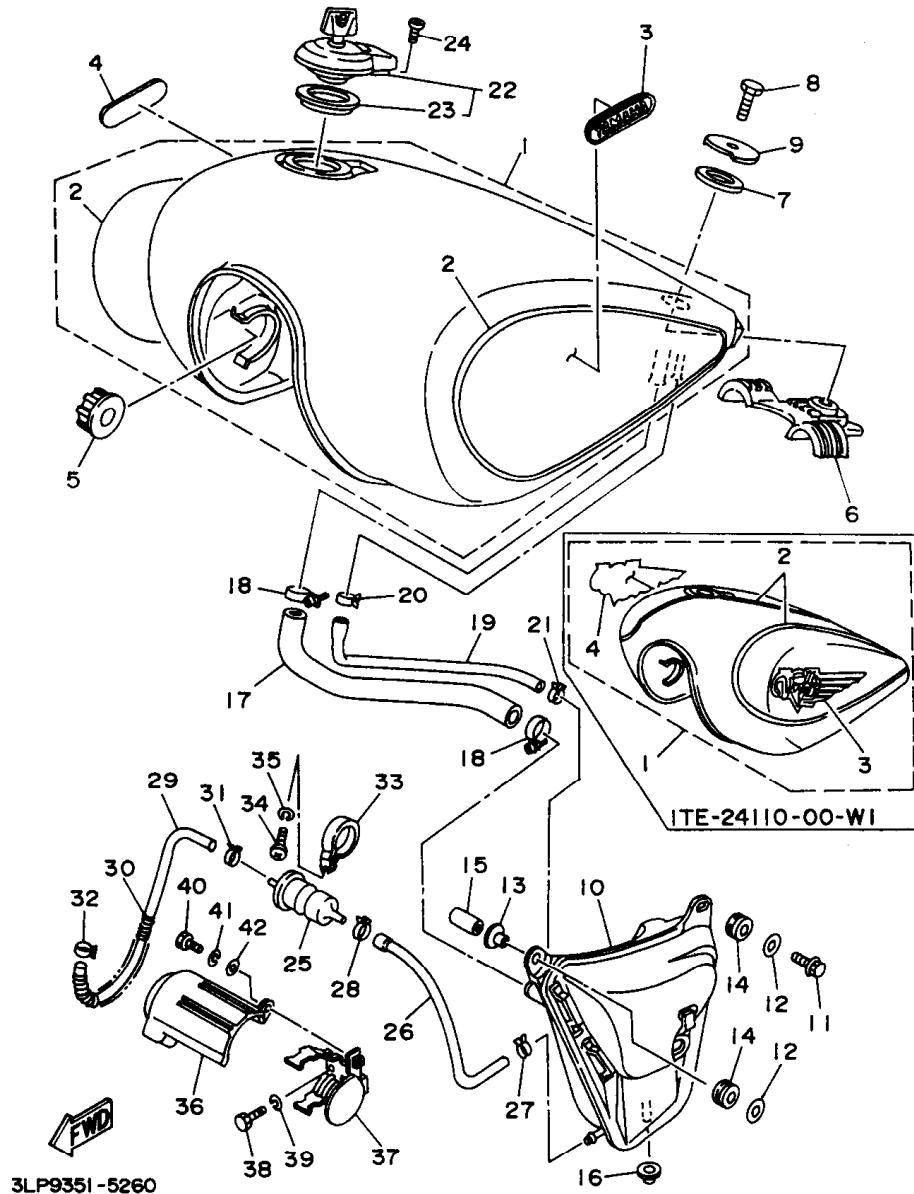

3LP9351-5260

REF. NO.	PART NO.	DESCRIPTION	QTY	REMARKS
25	1FK-24560-00	FILTER ASSY	1	
26	42H-24311-00	PIPE, FUEL 1	1	
27	90467-10135	CLIP	1	
28	90467-11044	CLIP	1	
29	42H-24315-00	PIPE 5	1	
30	90501-102A2	SPRING, COMPRESSION	1	UR
	90501-101J5	SPRING, COMPRESSION	1	UR FOR SPAIN, BLAZIL
31	90467-11044	CLIP	1	
32	90467-10135	CLIP	1	
33	90465-08256	CLAMP	1	
34	98507-06010	SCREW, PAN HEAD	1	
35	92907-06100	WASHER	1	
36	42H-24452-00	COVER	1	
37	3JK-24491-00	BRACKET, FUEL PUMP	1	
38	97007-06012	BOLT	2	
39	92907-06100	WASHER, SPRING	2	
40	98517-06012	SCREW, PAN HEAD	1	
41	92907-06100	WASHER	1	
42	92907-06600	WASHER	1	

D12

FIG. 27 SEAT

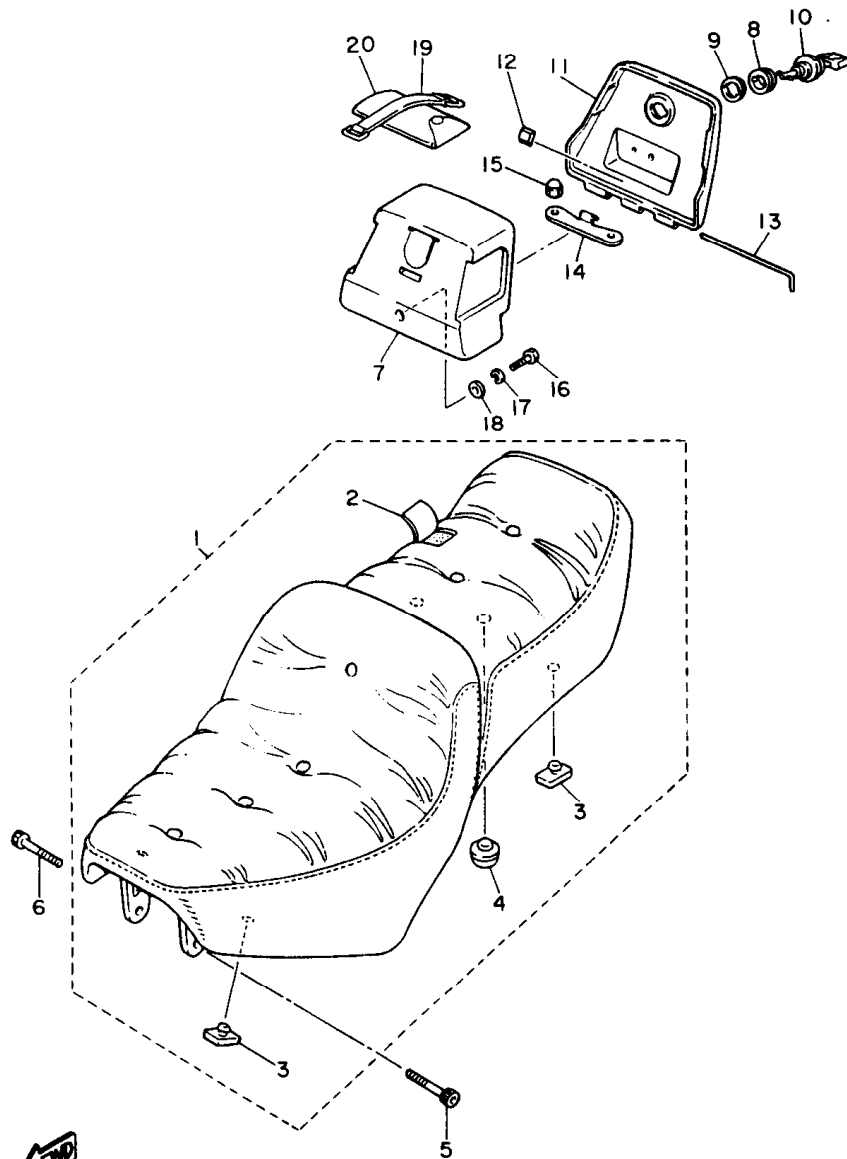

REF. NO.	PART NO.	DESCRIPTION	Q'TY	REMARKS
1	3CF-24730-10	DOUBLE SEAT ASSY	1	
2	3CF-24731-10	.COVER, SEAT	1	
3	509-24724-00	.DAMPER, SEAT	4	
4	1L9-24741-00	.PAD, SEAT	1	
5	91317-06016	BOLT	1	
6	90110-06077	BOLT, HEXAGON SOCKET HEAD	1	
7	42X-2473R-00	BOX 1	1	
8	90480-24186	GROMMET	1	
9	90201-225A4	WASHER, PLATE (T1.0)	1	
10	5A8-21708-00	SIDE COVER LOCK ASSY	1	
11	42X-2473T-00	LID 1	1	
12	3CF-24723-00	DAMPER, SEAT	1	
13	42X-2177K-00	PIN, HINGE	1	
14	1RM-2162G-00	PLATE 1	1	
15	90176-06041	NUT, CROWN	2	
16	97017-06016	BOLT	1	
17	92907-06100	WASHER, SPRING	1	
18	90201-06057	WASHER, PLATE	1	
19	5H9-21376-00	BAND, TOOL	1	
20	42X-28100-10	TOOL KIT	1	

3CF110-8270

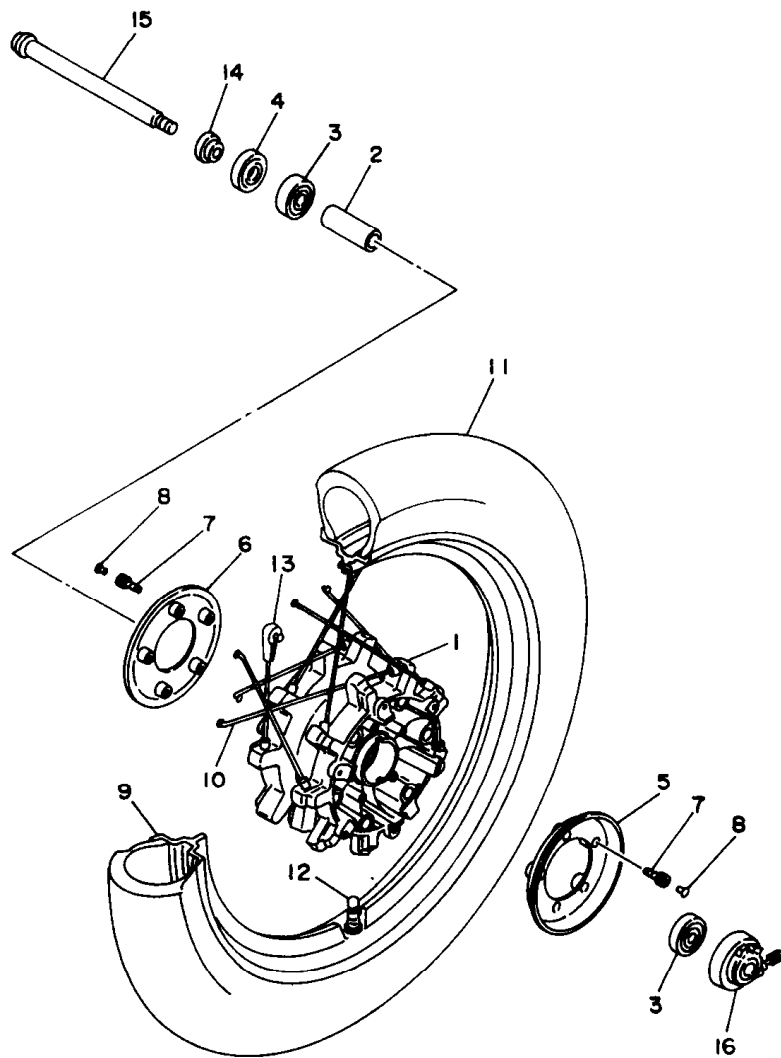

FIG. 28 FRONT WHEEL

REF. NO.	PART NO.	DESCRIPTION	Q'TY	REMARKS
1	3LP-25111-00-35	HUB, FRONT	1	SILVER
2	90560-15116	SPACER	1	
3	93306-30202	BEARING	2	
4	93102-22014	OIL SEAL	1	
5	56W-2512A-00	CAP, WHEEL (LEFT)	1	
6	56W-2512A-10	CAP, WHEEL (RIGHT)	1	
7	90110-06091	BOLT, HEXAGON SOCKET HEAD	10	
8	90338-06162	PLUG	10	
9	94421-19526	RIM (2.15-19)	1	
10	3LP-25104-00	SPOKE SET, FRONT	1	
11	94110-1904N	TIRE (100/90-19 57H)	1	UR BRIDGESTONE
	94110-1904P	TIRE (100/90-19 57H)	1	UR DUNLOP
12	93900-00030	VALVE, RIM	1	
13	3LP-25398-00	BALANCER, WHEEL	1	UN
	3LP-25398-10	BALANCER, WHEEL	1	UN
	3LP-25398-20	BALANCER, WHEEL	1	UN
14	90387-15550	COLLAR	1	
15	42X-25181-00	AXLE, WHEEL	1	
16	42X-25190-00	GEAR UNIT ASSY	1	



3LP7332-4280

D14

FIG. 29 FRONT BRAKE CALIPER

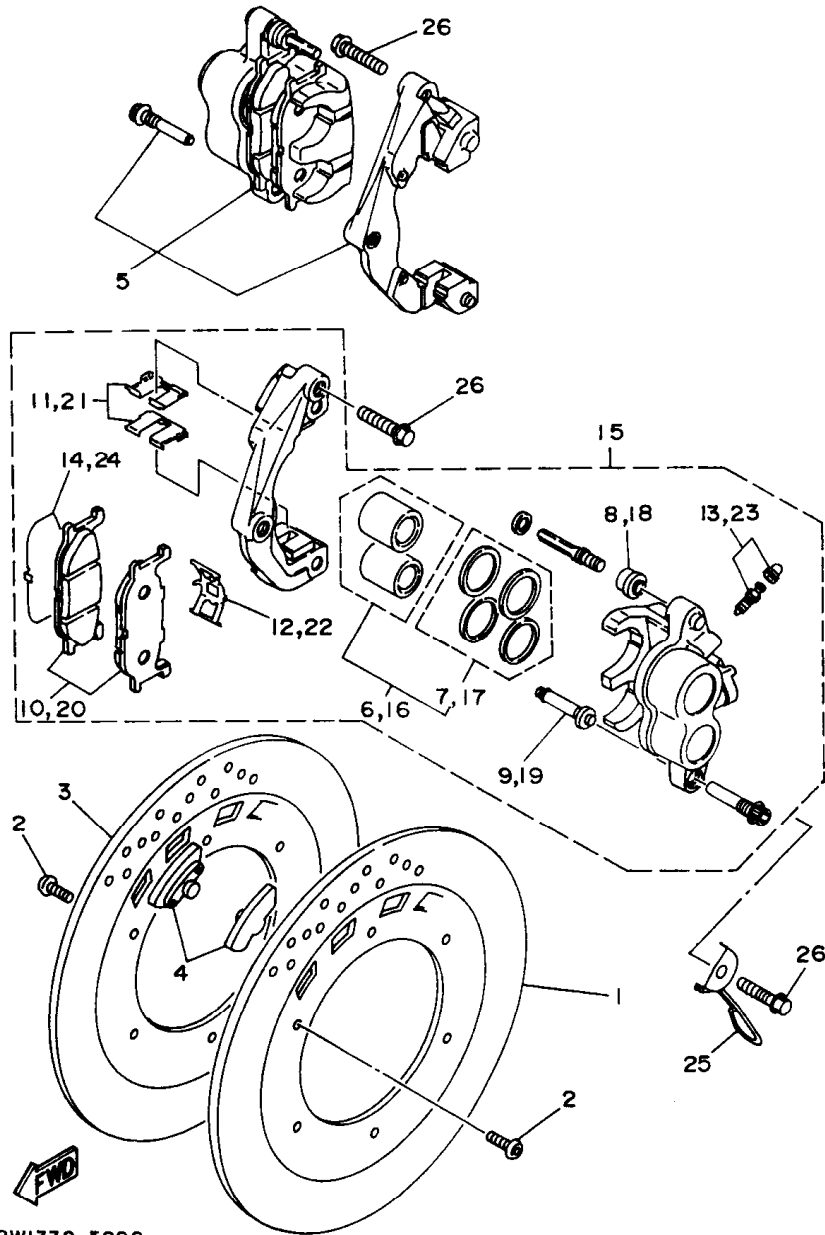

4PW1332-5290

REF. NO.	PART NO.	DESCRIPTION	Q'TY	REMARKS
1	3LP-2582T-00	DISC, BRAKE	1	
2	90109-08718	BOLT	12	
3	3LP-2582U-00	DISC, BRAKE (RIGHT)	1	
4	3LP-2516A-00	DAMPER	12	
5	3LP-2580U-00	CALIPER ASSY (RIGHT)	1	
6	3YX-W0057-50	.PISTON ASSY, CALIPER	1	
7	3YX-W0047-50	..CALIPER SEAL KIT	1	
8	5R2-25937-00	.BOOT 2	1	
9	3YX-25937-00	.BOOT 2	1	
10	3LP-W0045-00	.BRAKE PAD KIT	1	
11	3YX-25919-00	.SUPPORT, PAD	2	
12	3YX-25929-00	.SPRING, ANTI RATTLE	1	
13	51L-W0048-00	.BLEED SCREW KIT	1	
14	4DN-25827-00	.SHIM, CALIPER	1	
15	3LP-2580T-00	CALIPER ASSY (LEFT)	1	
16	3YX-W0057-50	.PISTON ASSY, CALIPER	1	
17	3YX-W0047-50	..CALIPER SEAL KIT	1	
18	5R2-25937-00	.BOOT 2	1	
19	3YX-25937-00	.BOOT 2	1	
20	3LP-W0045-00	.BRAKE PAD KIT	1	
21	3YX-25919-00	.SUPPORT, PAD	2	
22	3YX-25929-00	.SPRING, ANTI RATTLE	1	
23	51L-W0048-00	.BLEED SCREW KIT	1	
24	4DN-25827-00	.SHIM, CALIPER	1	
25	3LP-23317-00	HOLDER, CABLE	1	
26	90105-10638	BOLT, WASHER BASED	4	

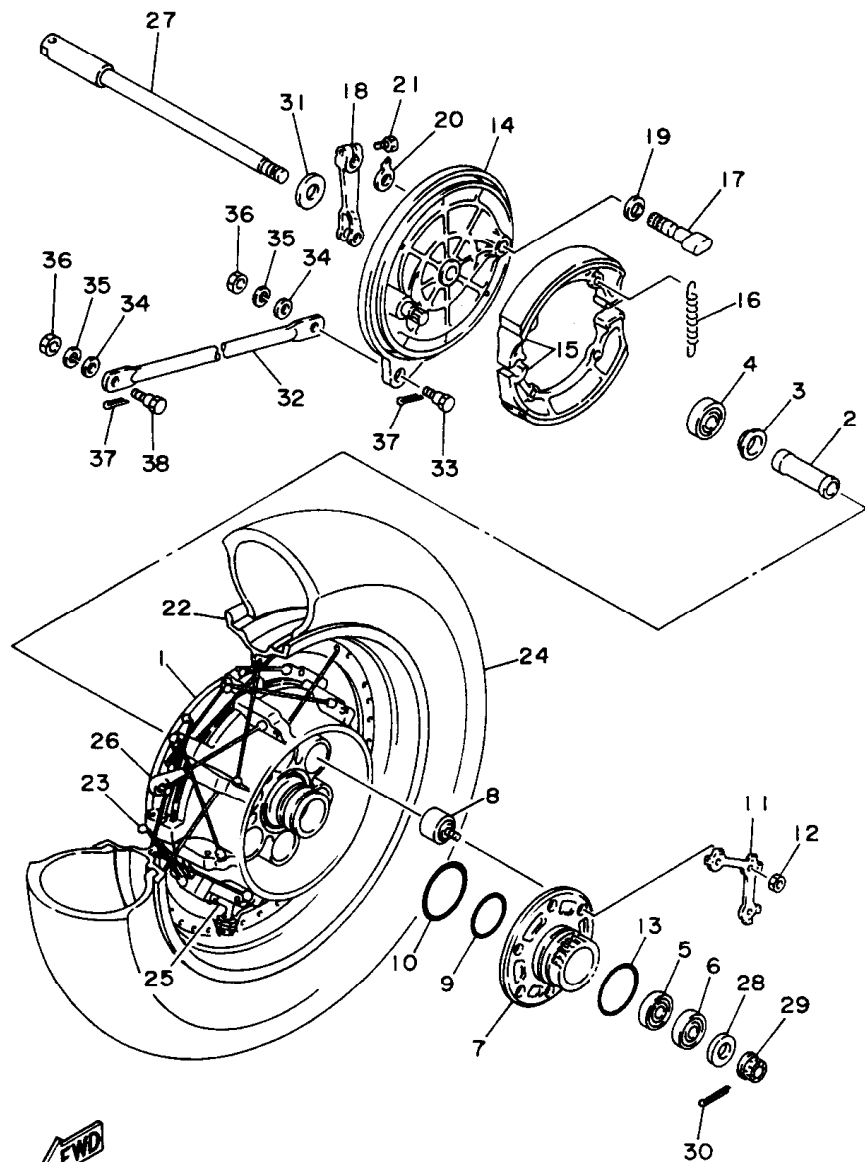

3LP7351-4300

FIG. 30 REAR WHEEL

REF. NO.	PART NO.	DESCRIPTION	Q'TY	REMARKS
1	3LP-25311-00-35	HUB, REAR	1	SILVER
2	90560-17249	SPACER	1	
3	146-25315-00	FLANGE, SPACER	1	
4	93306-30309	BEARING (B6303ZZ)	1	
5	93306-20310	BEARING (B6203DU)	1	
6	93306-20310	BEARING (B6203DU)	1	
7	16G-25366-01	CLUTCH, HUB	1	
8	42H-25364-00	DAMPER	6	
9	93210-48530	O-RING	1	
10	93210-59531	O-RING	1	
11	16G-25412-00	WASHER	2	
12	90170-10219	NUT	6	
13	93210-57428	O-RING	1	
14	42H-25321-02	PLATE, BRAKE SHOE	1	
15	3DR-W2536-00	BRAKE SHOE SET	1	
16	90507-20002	SPRING, TENSION	2	
17	4H7-25351-00	CAMSHAFT	1	
18	3CF-25355-00	LEVER, CAMSHAFT	1	
19	90201-14218	WASHER, PLATE	1	
20	4H7-2533A-02	PLATE, INDICATOR	1	
21	90101-06764	BOLT	1	
22	94430-15525	RIM	1	
23	3LP-25304-00	SPOKE SET, REAR	1	
24	94114-1504R	TIRE (140/90-15 70H)	1	UR BRIDGESTONE
	94114-1504S	TIRE (140/90-15 70H)	1	UR DUNLOP
25	93900-00016	VALVE, RIM	1	BRIDGESTONE
26	3LP-25398-00	BALANCER, WHEEL	1	UN
	3LP-25398-10	BALANCER, WHEEL	1	UN

FIG. 30 REAR WHEEL

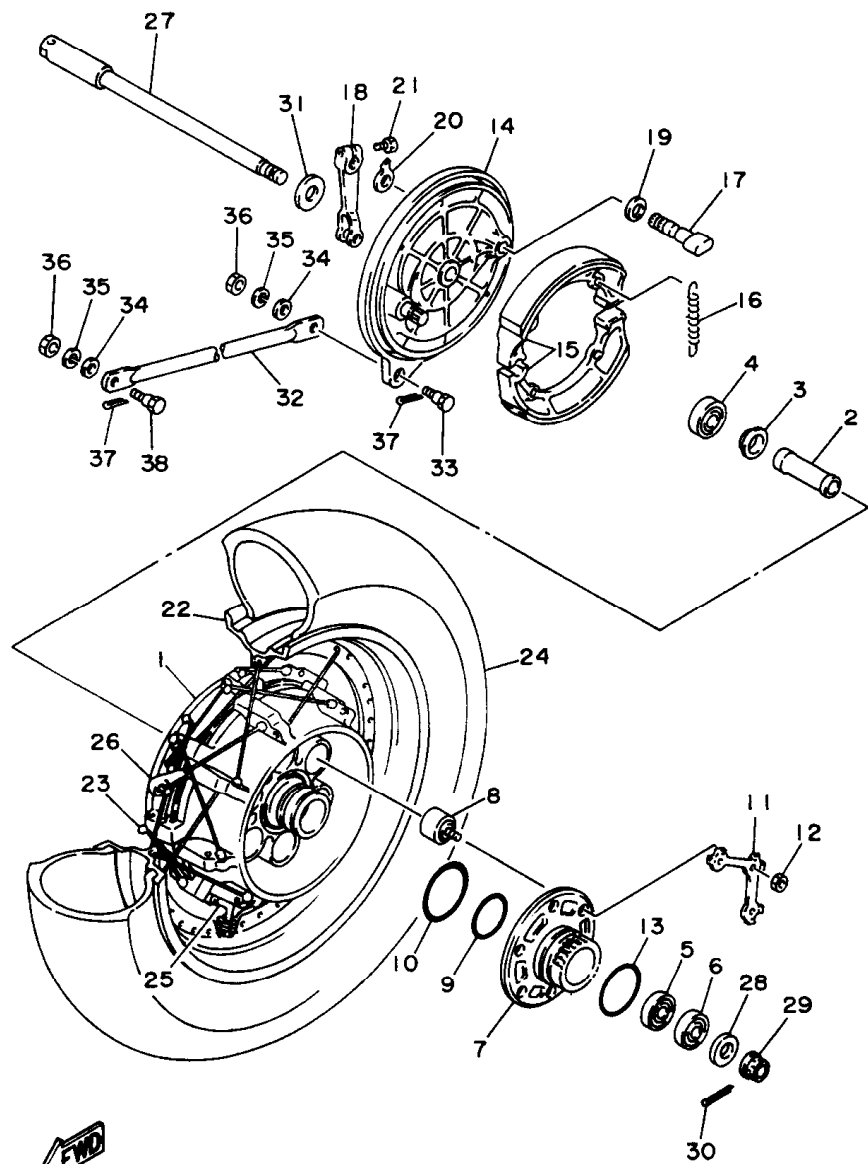

REF. NO.	PART NO.	DESCRIPTION	Q'TY	REMARKS
26	3LP-25398-20	BALANCER, WHEEL	1	UN
27	42X-25381-00	AXLE, WHEEL	1	
28	90201-146R0	WASHER, PLATE	1	
29	90171-14044	NUT, CASTLE	1	
30	91401-30030	PIN, COTTER	1	
31	4H7-25377-00	COLLAR, WHEEL	1	
32	42X-25371-00	BAR, TENSION	1	
33	90109-08406	BOLT	1	
34	92990-08600	WASHER, PLATE	2	
35	92990-08100	WASHER, SPRING	2	
36	95304-08700	NUT	2	
37	91490-20020	PIN, COTTER	2	
38	90109-08368	BOLT	1	

3LP7351-4300

E3

FIG. 31 STEERING HANDLE. CABLE

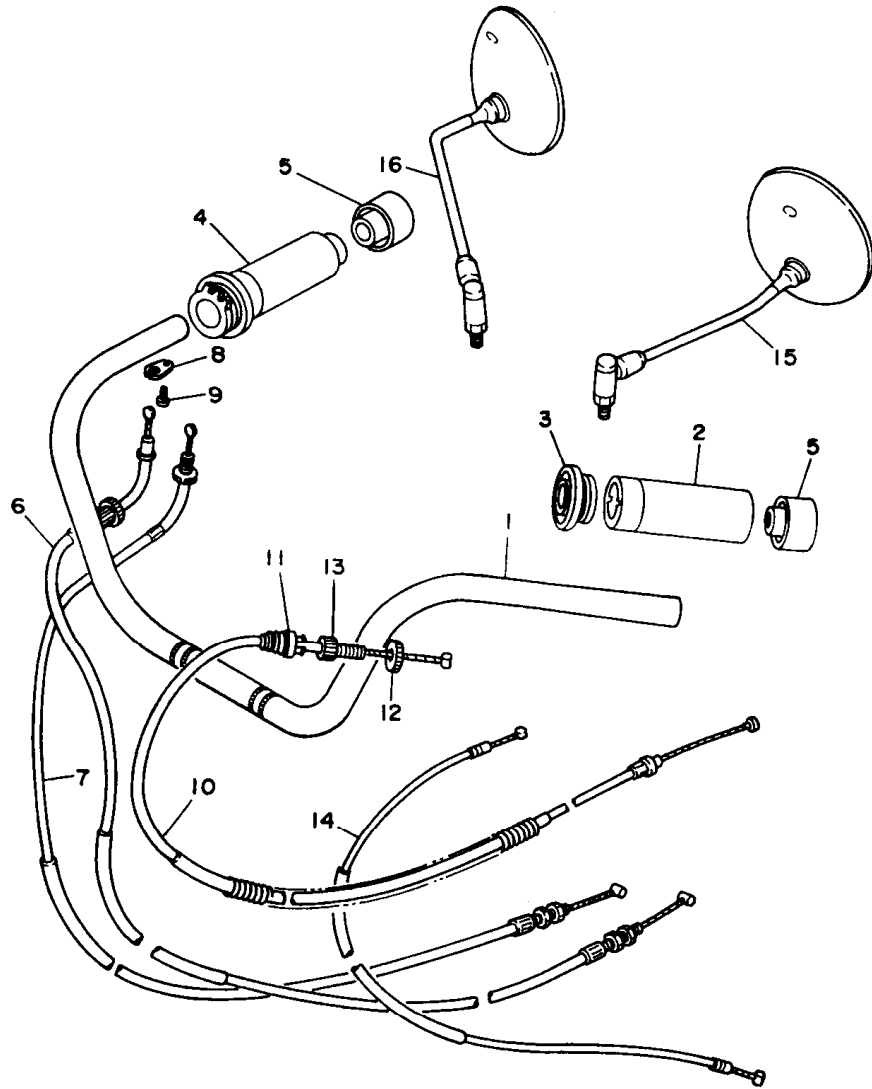

REF. NO.	PART NO.	DESCRIPTION	Q'TY	REMARKS
1	3CF-W2611-10	HANDLEBAR	1	
2	3JB-26241-00	GRIP (LEFT)	1	
3	3JB-26273-00	ROTOR	1	
4	3JB-26240-00	GRIP ASSY	1	
5	3JB-2628J-00	CAP, GRIP	2	
6	3CF-26311-00	CABLE, THROTTLE 1	1	
7	3CF-26312-00	CABLE, THROTTLE 2	1	
8	5H0-26393-00	HOLDER	1	
9	98507-05008	SCREW, PAN HEAD	1	
10	57A-26335-00	CABLE, CLUTCH	1	
11	1E6-26342-00	BOOT, CABLE	1	
12	90179-08148	NUT	1	
13	90123-08046	BOLT	1	
14	3CF-26331-01	CABLE, STARTER 1	1	
15	1J7-26290-F0	REAR VIEW MIRROR ASSY (LEFT)	1	
16	1J7-26290-G0	REAR VIEW MIRROR ASSY (RIGHT)	1	



3LP4332-2310

E4

FIG. 32 FRONT MASTER CYLINDER

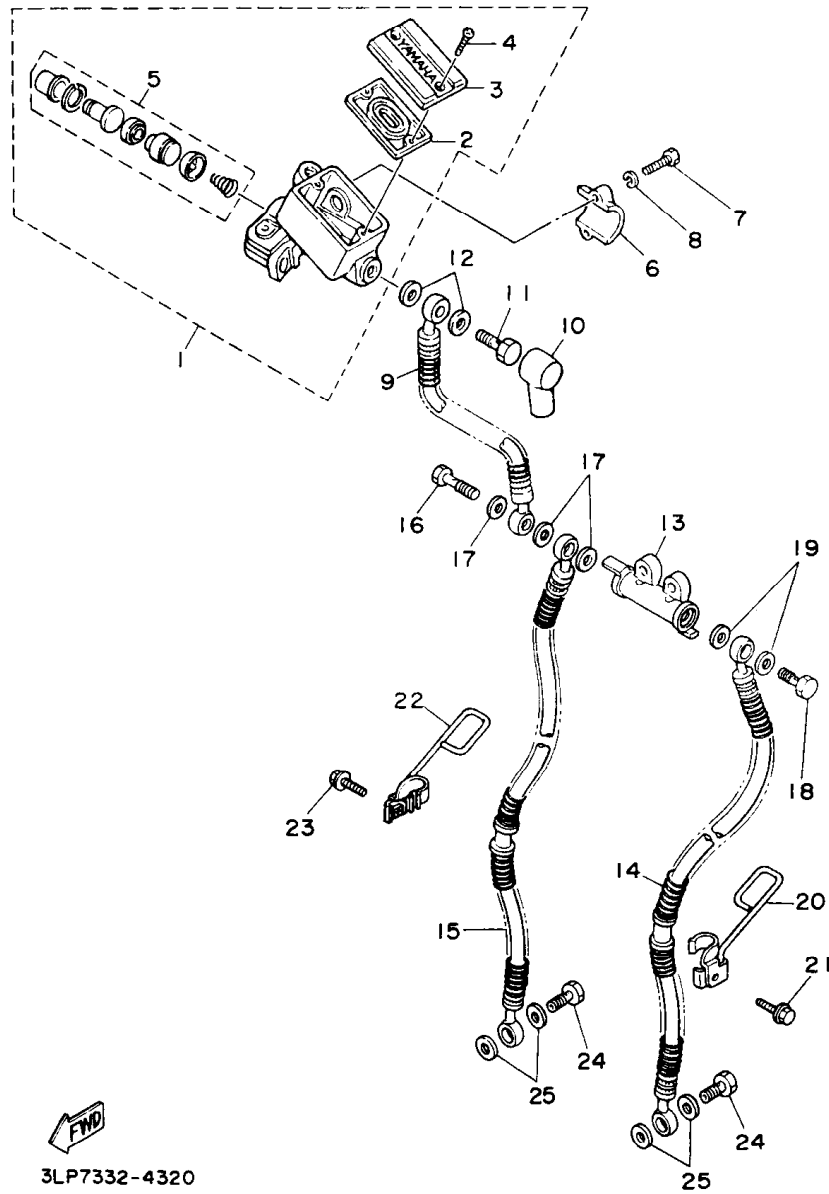

3LP7332-4320

REF. NO.	PART NO.	DESCRIPTION	Q'TY	REMARKS
1	22R-25850-02	MASTER CYLINDER ASSY	1	
2	4K0-25854-00	.DIAPHRAGM, RESERVOIR	1	
3	3GM-25852-01	.CAP, RESERVOIR	1	
4	98707-04012	.SCREW, FLAT HEAD	2	
5	4K0-W0041-50	.CYLINDER KIT, MASTER	1	
6	4L0-25867-00	BRACKET, MASTER CYLINDER	1	
7	97007-06025	BOLT	2	
8	92907-06100	WASHER, SPRING	2	
9	3LP-25872-11	HOSE, BRAKE 1	1	
10	4L0-25862-00	BOOT, MASTER CYLINDER	1	
11	90401-10159	BOLT, UNION	1	
12	90201-10118	WASHER, PLATE	2	
13	42H-25885-01	JOINT	1	
14	3LP-25873-10	HOSE, BRAKE 2	1	
15	3LP-25874-10	HOSE, BRAKE	1	
16	90401-10160	BOLT, UNION	1	
17	90201-10118	WASHER, PLATE	3	
18	90401-10159	BOLT, UNION	1	
19	90201-10118	WASHER, PLATE	2	
20	55R-25875-00	HOLDER, BRAKE HOSE 1	1	
21	95024-06020	BOLT	1	
22	55R-25876-00	HOLDER, BRAKE HOSE 2	1	
23	95024-06020	BOLT	1	
24	90401-10159	BOLT, UNION	2	
25	90201-10118	WASHER, PLATE	4	

E5

FIG. 33 STAND. FOOTREST

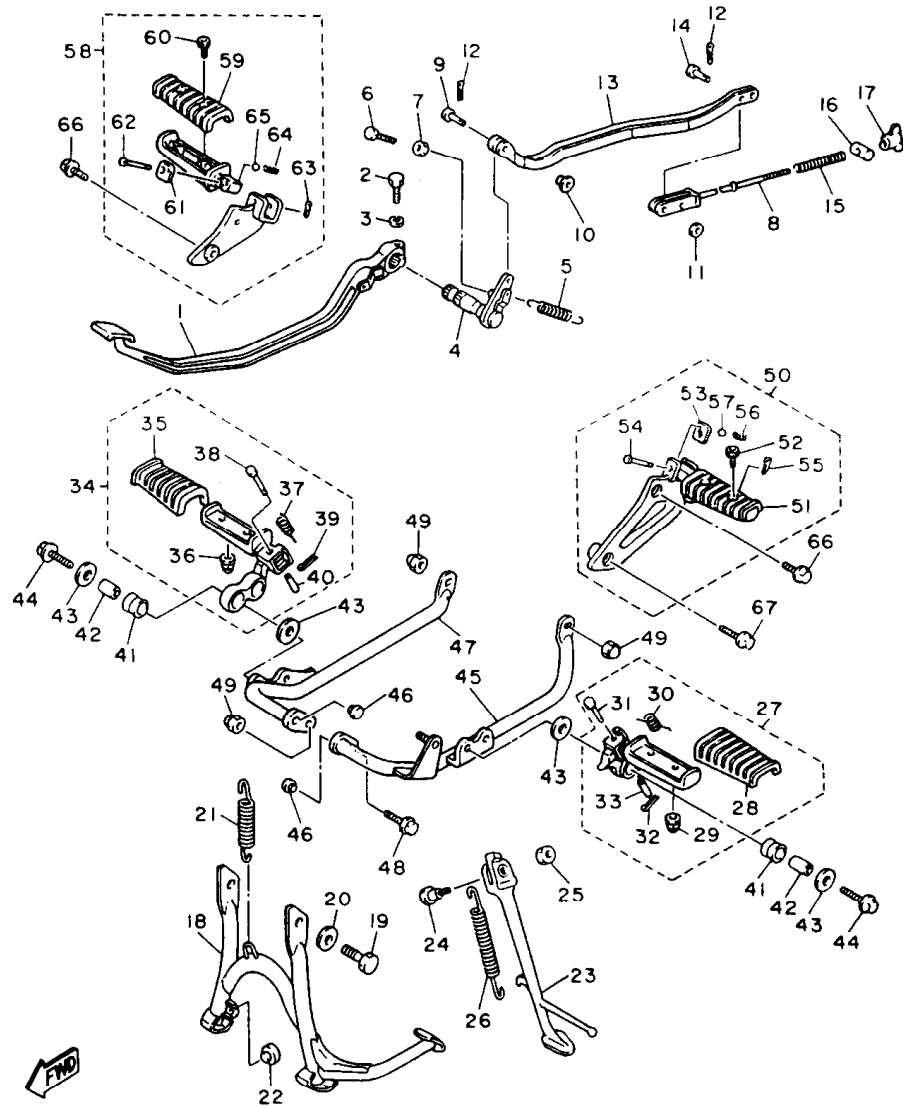

3CF110-8330

REF. NO.	PART NO.	DESCRIPTION	Q'TY	REMARKS
1	3CF-27211-00-93	PEDAL, BRAKE	1	CHROME PLATED
2	90109-06468	BOLT	1	
3	92995-06100	WASHER, SPRING	1	
4	42X-27212-01	SHAFT, BRAKE PEDAL	1	
5	90506-20192	SPRING, TENSION	1	
6	90101-06478	BOLT	1	
7	90170-06184	NUT	1	
8	3CF-27231-01	ROD, BRAKE	1	
9	90240-06057	PIN, CLEVIS	1	
10	90560-06201	SPACER	1	
11	92907-06200	WASHER, PLAIN	2	
12	91490-20020	PIN, COTTER	3	
13	3CF-27241-00	ROD, JOINT	1	
14	90240-06103	PIN, CLEVIS	2	
15	90501-10245	SPRING, COMPRESSION	1	
16	90249-12008	PIN	1	
17	90175-06019	NUT, WING	1	
18	42X-27111-00-R4	STAND, MAIN	1	BLACK (FOR ELECTRODEPOSIT)
19	97007-10016	BOLT	2	
20	90201-10752	WASHER, PLATE	2	
21	90506-35149	SPRING, TENSION	1	
22	371-27114-00	STOPPER, MAIN STAND	1	
23	42X-27311-00-93	STAND, SIDE	1	CHROME PLATED
24	90109-10163	BOLT	1	
25	95304-10700	NUT	1	
26	90507-29009	SPRING, TENSION	1	
27	3CF-27410-00-93	FRONT FOOTREST ASSY (LEFT)	1	CHROME PLATED
28	1NH-27413-00	.COVER, FOOTREST	1	

E6

FIG. 33 STAND. FOOTREST

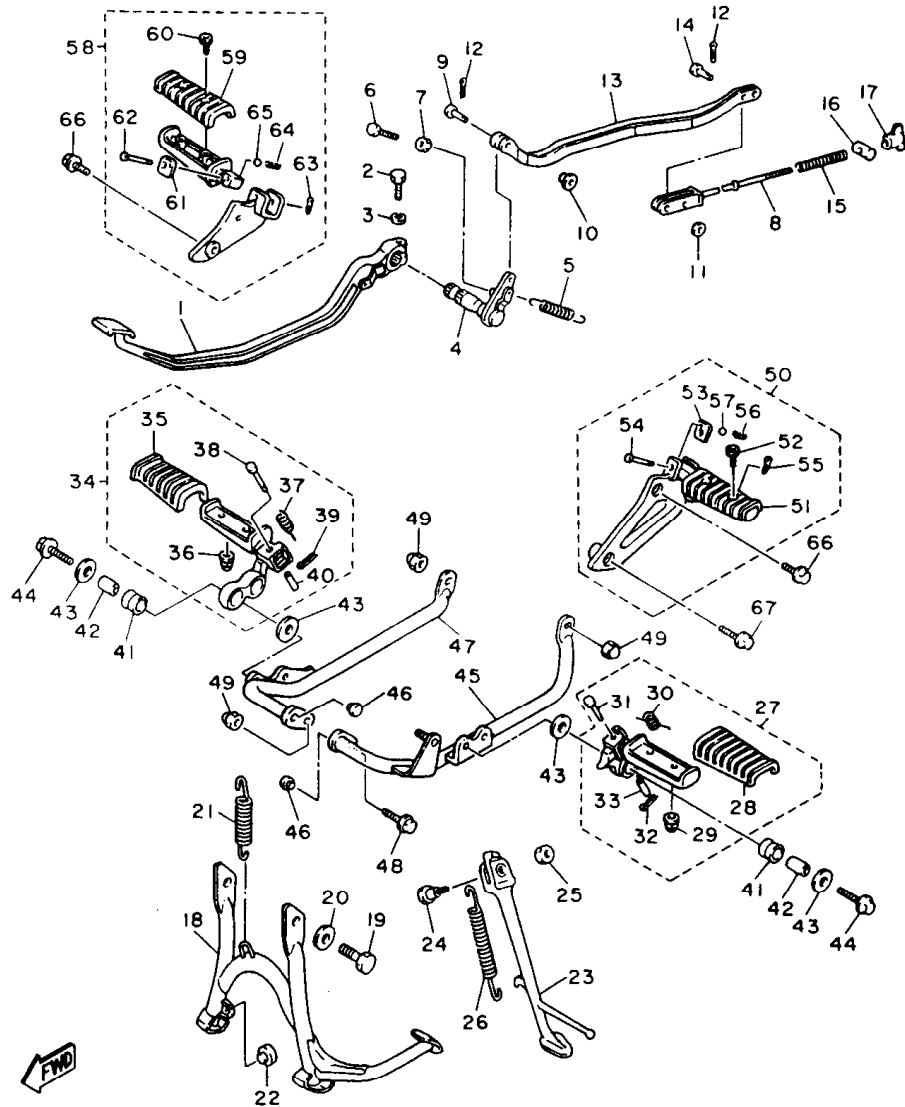

3CF110-8330

REF. NO.	PART NO.	DESCRIPTION	Q'TY	REMARKS
29	95601-06100	.NUT, U	2	
30	90508-18696	.SPRING, TORSION	1	
31	91701-08038	.PIN, CLEVIS	1	
32	91401-25020	.PIN, COTTER	1	
33	90387-087K5	.COLLAR	1	
34	1RM-27420-00-93	FRONT FOOTREST ASSY (RIGHT)	1	CHROME PLATED
35	1NH-27413-00	.COVER, FOOTREST	1	
36	95607-06100	.NUT, U	2	
37	90508-18696	.SPRING, TORSION	1	
38	91701-08038	.PIN, CLEVIS	1	
39	91401-25020	.PIN, COTTER	1	
40	90387-087K5	.COLLAR	1	
41	4X7-27414-00	DAMPER, FOOTREST	4	
42	90387-107A7	COLLAR	4	
43	90201-100A1	WASHER, PLATE	8	
44	90109-100G0	BOLT	4	
45	3CF-27471-01	BAR, FOOTREST 1 ✓	1	
46	90338-09012	PLUG	2	
47	3CF-27472-01	BAR, FOOTREST 2	1	
48	90105-10050	BOLT, WASHER BASED	1	
49	90176-10075	NUT, CROWN	3	
50	1RM-27430-01	REAR FOOTREST ASSY 1	1	
51	1NH-27433-00	.COVER, REAR FOOTREST	1	
52	98517-06012	.SCREW, PAN HEAD	2	
53	1HX-27437-00	.WASHER, SPECIAL	1	
54	91701-06038	.PIN, CLEVIS	1	
55	91490-16020	.PIN, COTTER	1	
56	90501-12743	.SPRING, COMPRESSION	1	

E7

FIG. 33 STAND. FOOTREST

REF. NO.	PART NO.	DESCRIPTION	QTY	REMARKS
57	93501-04011	.BALL	1	
58	1RM-27440-01	REAR FOOTREST ASSY 2	1	
59	1NH-27433-00	.COVER, REAR FOOTREST	1	
60	98517-06012	.SCREW, PAN HEAD	2	
61	1HX-27437-00	.WASHER, SPECIAL	1	
62	91701-06038	.PIN, CLEVIS	1	
63	91490-16020	.PIN, COTTER	1	
64	90501-12743	.SPRING, COMPRESSION	1	
65	93501-04011	.BALL	1	
66	95024-08020	BOLT, FLANGE	3	
67	95024-08045	BOLT, FLANGE	1	

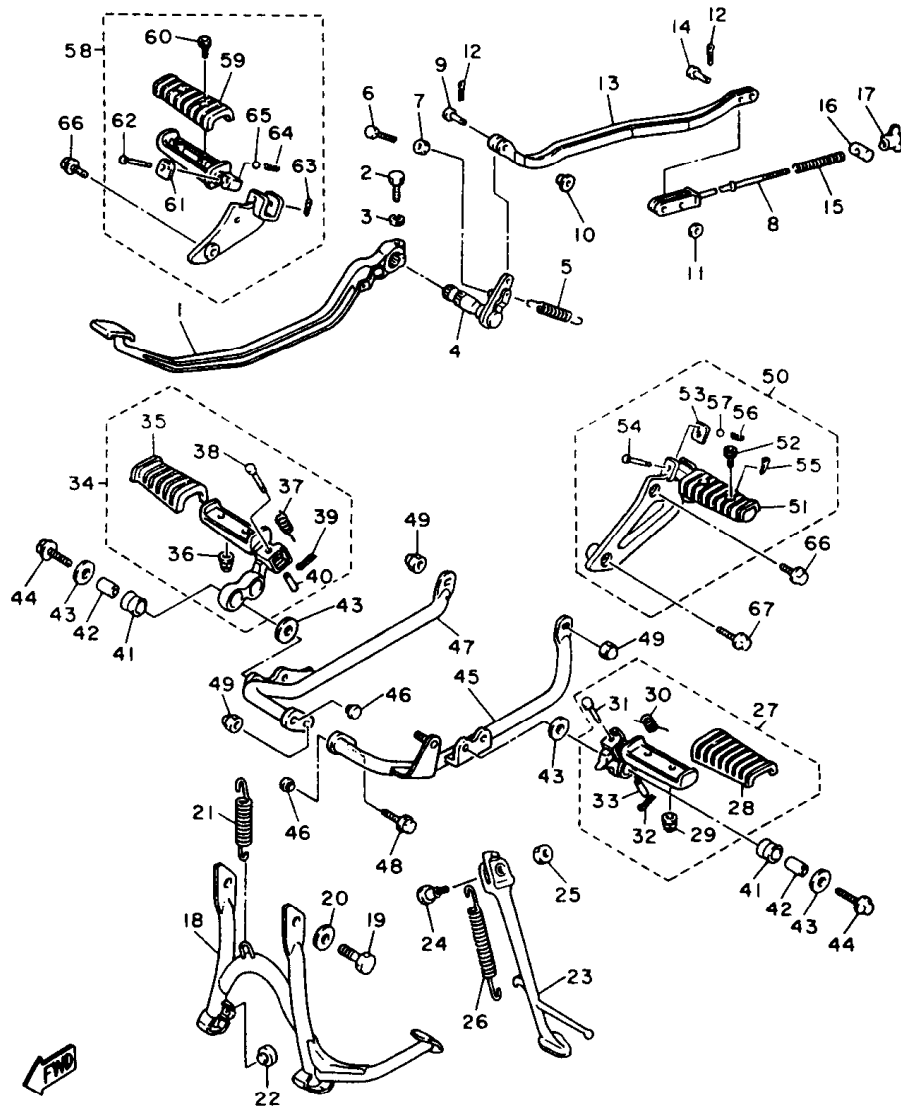

3CF110-8330

FIG. 34 GENERATOR

REF. NO.	PART NO.	DESCRIPTION	Q'TY	REMARKS
1	3JK-81450-00	ROTOR ASSY	1	
2	1RM-81410-20	STATOR ASSY	1	
3	91317-06030	BOLT	3	
4	3JK-81670-00	PICK-UP ASSY	1	
5	91317-06016	BOLT	2	
6	90201-06643	WASHER, PLATE	2	

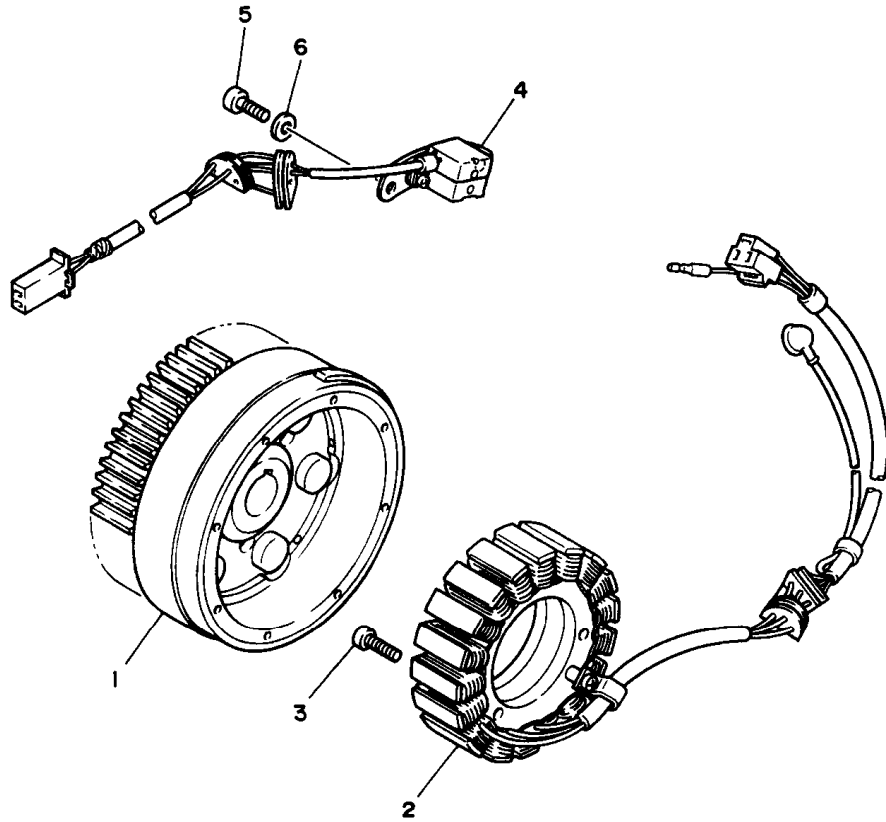

3JK7110-1340

FIG. 35 STARTING MOTOR

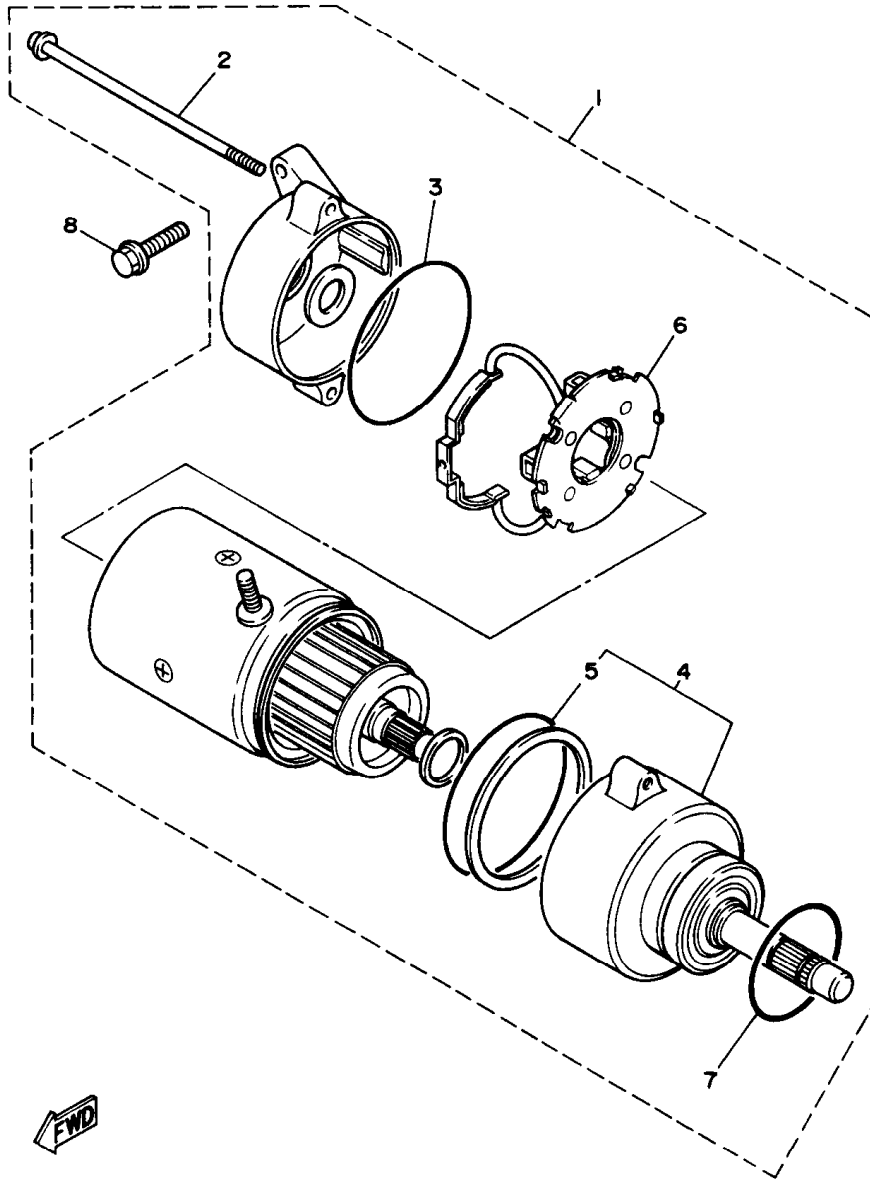

REF. NO.	PART NO.	DESCRIPTION	Q'TY	REMARKS
1	5A8-81800-10	STARTING MOTOR ASSY	1	
2	5A8-81826-10	.BOLT	2	
3	11H-81844-00	.GASKET	1	
4	5A8-81830-10	.FRONT BRACKET ASSY	1	
5	5A8-81847-10	..O-RING	1	
6	5A8-81840-10	.BRUSH HOLDER ASSY	1	
7	1J7-81847-60	.O-RING	1	
8	95817-06025	BOLT, FLANGE	2	



3JK4110-0350

E10

FIG. 36 FLASHER LIGHT

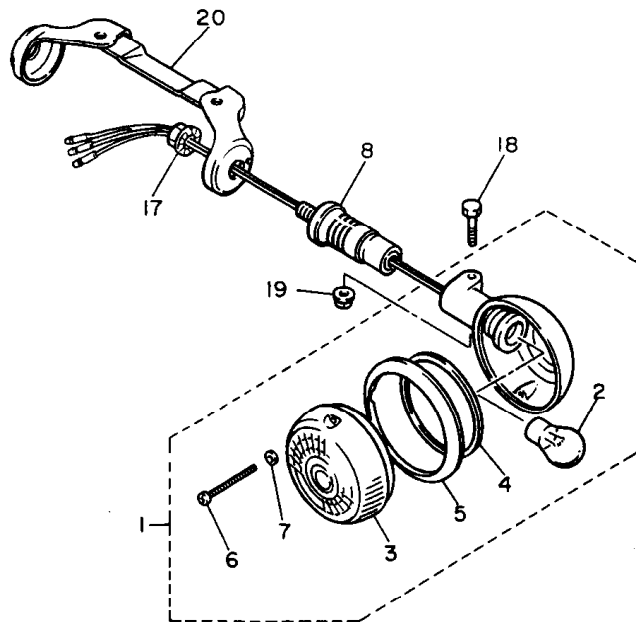
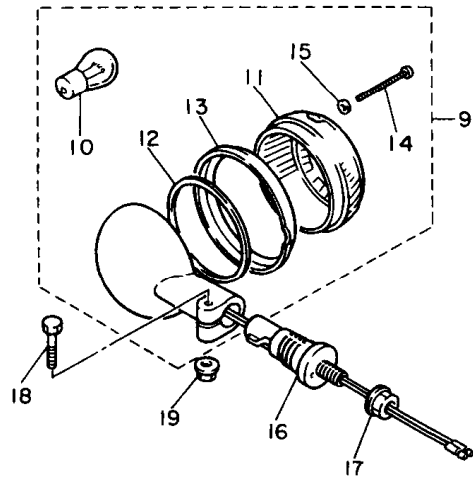

REF. NO.	PART NO.	DESCRIPTION	Q'TY	REMARKS
1	2EN-83310-00	FRONT FLASHER LIGHT ASSY 1	2	
2	1KT-83311-00	.BULB (12V 21W)	1	
3	42X-83312-00	.LENS, FLASHER	1	
4	42X-83313-00	.GASKET, FLASHER LENS	1	
5	42X-83363-00	.LENS, RIM	1	
6	98507-03020	.SCREW, PAN HEAD	2	
7	42X-83359-00	.WASHER, SPECIAL	2	
8	1AA-83318-00	STAY, FLASHER 1	2	
9	2EN-83330-00	REAR FLASHER LIGHT ASSY 1	2	
10	1KT-83311-00	.BULB (12V-21W)	1	
11	2AE-83312-00	.LENS, FLASHER	1	
12	42X-83313-00	.GASKET, FLASHER LENS	1	
13	42X-83363-00	.LENS, RIM	1	
14	341-83333-70	.SCREW, LENS FITTING	2	
15	42X-83359-00	.WASHER, SPECIAL	2	
16	1AA-83328-00	STAY, FLASHER 2	2	UR
	1AA-83318-00	STAY, FLASHER 1	2	UR FOR SWITZERLAND, AUSTRIA
17	95707-12500	NUT, FLANGE	4	
18	97024-06030	BOLT	4	
19	95704-06500	NUT, FLANGE	4	
20	42X-83328-00	STAY, FLASHER 2	1	



42W110-4360

E11

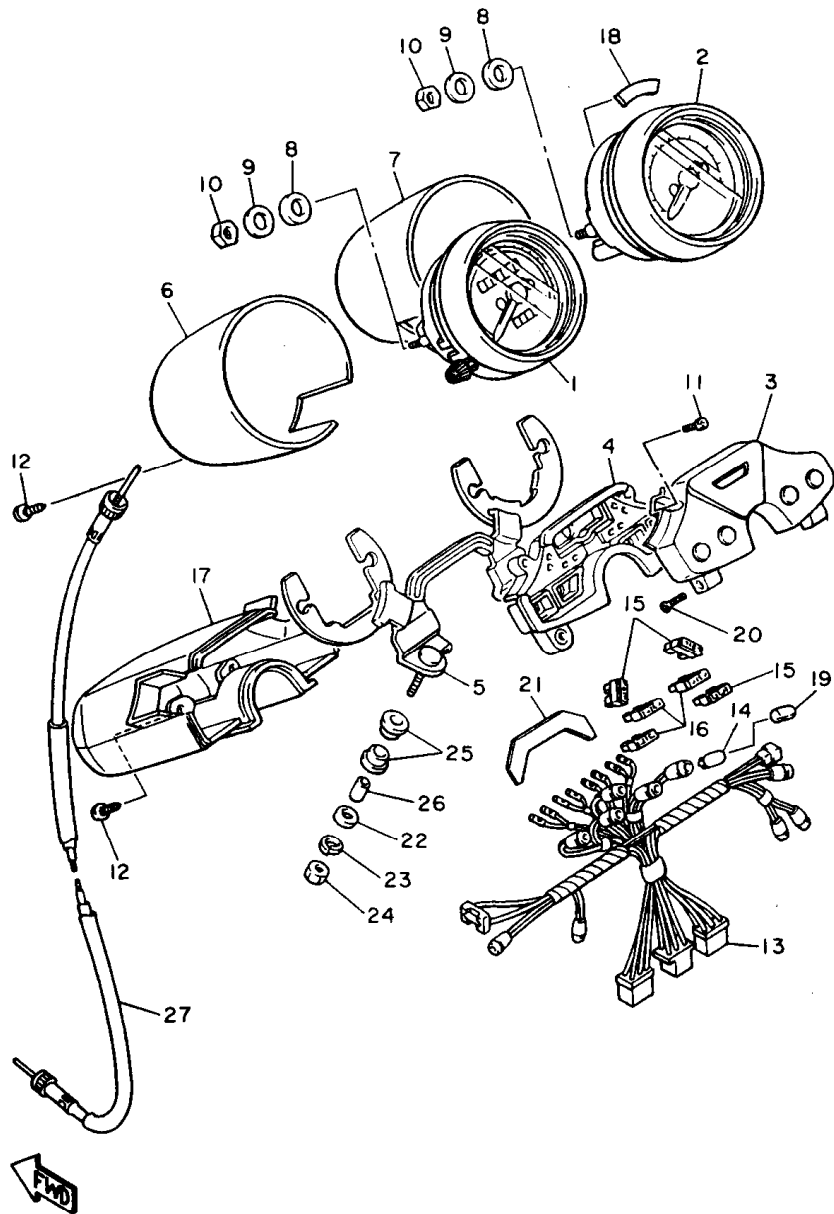

3CF110-8370

FIG. 37 METER

REF. NO.	PART NO.	DESCRIPTION	QTY	REMARKS
1	1FL-83570-F0	SPEEDOMETER ASSY	1	
2	1RM-83540-00	TACHOMETER ASSY	1	
3	3LP-8353E-00	CASE, METER UPPER	1	UR
	3CF-8353E-00	CASE, METER UPPER	1	UR FOR SWITZERLAND, AUSTRIA, ENGLAND, SPAIN, BRAZIL
4	3CF-8353H-00	CASE, UNDER	1	
5	1FG-83519-00	BRACKET, METER	1	
6	42X-83507-00	COVER, SPEEDOMETER	1	METALLIC CHROME
7	42X-83508-00	COVER, TACHOMETER	1	METALLIC CHROME
8	1FG-83523-00	DAMPER	4	
9	90201-05031	WASHER, PLATE	4	
10	95307-05600	NUT	4	
11	98507-04008	SCREW, PAN HEAD	2	
12	97707-40014	SCREW, TAPPING	6	
13	1RM-83509-00	SOCKET CORD ASSY	1	
14	42X-83517-00	BULB (12V-3W)	10	
15	36Y-82151-00	FUSE (15A-BL)	3	
16	42X-82151-20	FUSE (10A)	3	
17	42X-83559-00	COVER, METER	1	
18	1FK-83523-00	DAMPER	1	
19	1FK-83535-00	TUBE	4	
20	98707-04010	SCREW, FLAT HEAD	2	
21	55R-83579-00	COVER, METER 2	1	
22	92907-06200	WASHER, PLAIN	2	
23	92907-06100	WASHER, SPRING	2	
24	95317-06600	NUT	2	
25	584-83541-00	DAMPER	4	
26	90387-06249	COLLAR	2	
27	3LP-83550-00	SPEEDOMETER CABLE ASSY	1	

E12

FIG. 38 HEADLIGHT

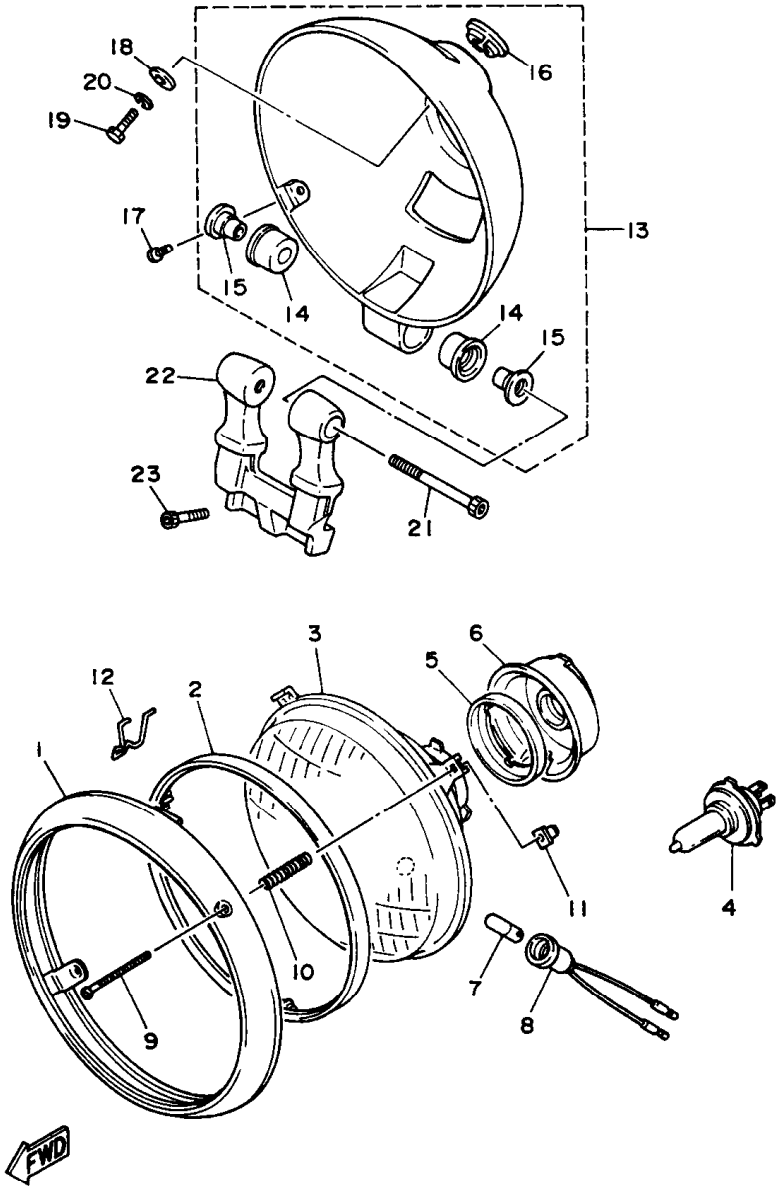

REF. NO.	PART NO.	DESCRIPTION	Q'TY	REMARKS
1	42X-84315-01	RIM, HEADLIGHT	1	
2	5Y3-84395-00	RING, RETAINING	1	
3	2AE-84320-60	LENS ASSY	1	
4	*	BULB (12V-60/55W)	1	LM (H4)HALOGEN
5	2F9-84375-00	SETTING PLATE, BULB	1	
6	2F9-84397-01	COVER, SOCKET	1	
7	*	BULB (12V-4W)	1	LM
8	34L-84346-00	SOCKET, PILOT LIGHT	1	
9	90157-04001	SCREW, PAN HEAD	2	
10	1A0-84332-60	SPRING, SCREW	2	
11	198-84334-60	NUT, ADJUSTING	2	
12	42X-84124-60	SPRING, SET	1	
13	42X-84330-01	BODY ASSY	1	EMPRESS MAROON
14	42X-84345-00	.DAMPER, HEADLIGHT	2	
15	42X-84338-00	.COLLAR, BODY FITTING	2	
16	42X-84366-00	.DAMPER, HEADLIGHT 1	1	
17	90157-05084	SCREW, PAN HEAD	2	
18	90201-06073	WASHER, PLATE	1	
19	97017-06016	BOLT, HEXAGON	1	
20	92907-06100	WASHER, SPRING	1	
21	91317-08055	BOLT	1	
22	42X-84318-00	STAY, HEADLIGHT 1	1	
23	91316-06025	BOLT	2	

3LP7332-4380

E13

FIG. 39 TAILLIGHT

REF. NO.	PART NO.	DESCRIPTION	Q'TY	REMARKS
1	2EM-84700-E0	TAILLIGHT ASSY	1	
2	2AE-84721-00	.LENS, TAILLIGHT	1	
3	42X-84723-01	.GASKET, TAIL LENS	1	
4	1RM-84704-00	.GASKET, TAILLIGHT	1	
5	97707-40625	.SCREW, TAPPING	2	
6	31L-84714-00	.BULB, TAILLIGHT (12V-21/5W)	2	
7	90119-06097	BOLT, WITH WASHER	3	
8	90387-065L5	COLLAR	3	
9	90480-14229	GROMMET	3	
10	90480-16501	GROMMET	1	
11	90480-01502	GROMMET	1	
12	2YL-84751-00	BRACKET, LICENSE	1	
13	95807-06016	BOLT, FLANGE	2	
14	92907-06600	WASHER, PLATE	2	
15	95307-06600	NUT	2	

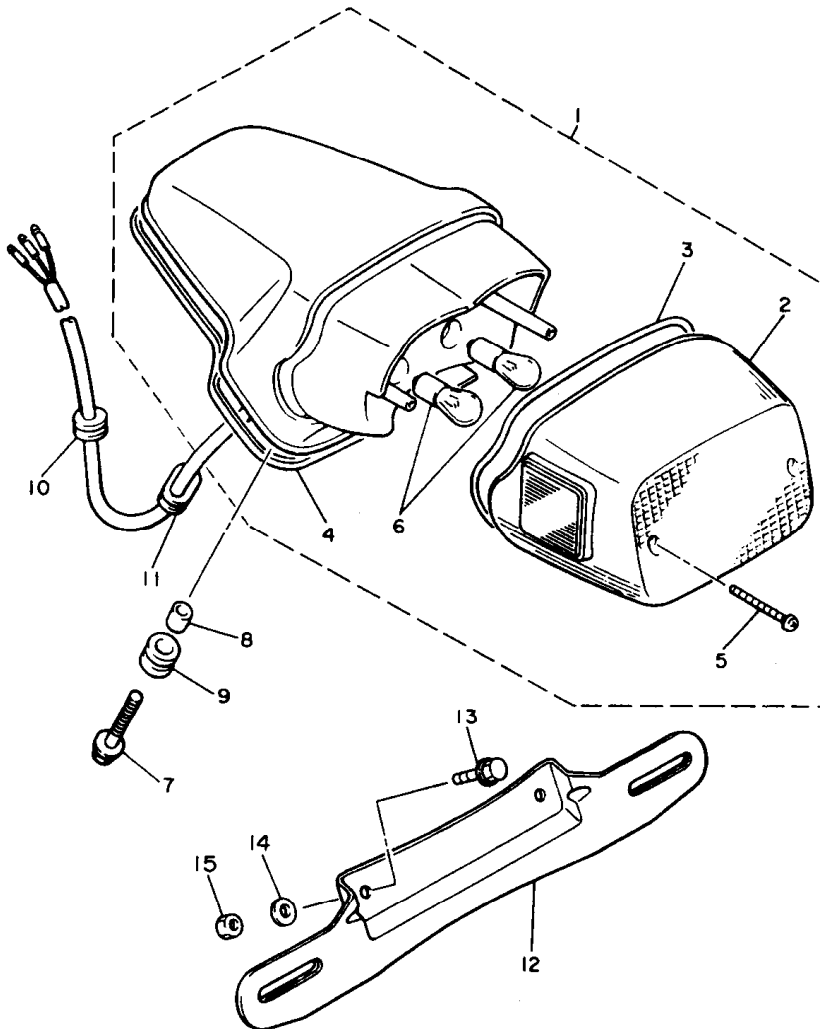

3LP7332-4390

E14

FIG. 40 HANDLE SWITCH. LEVER

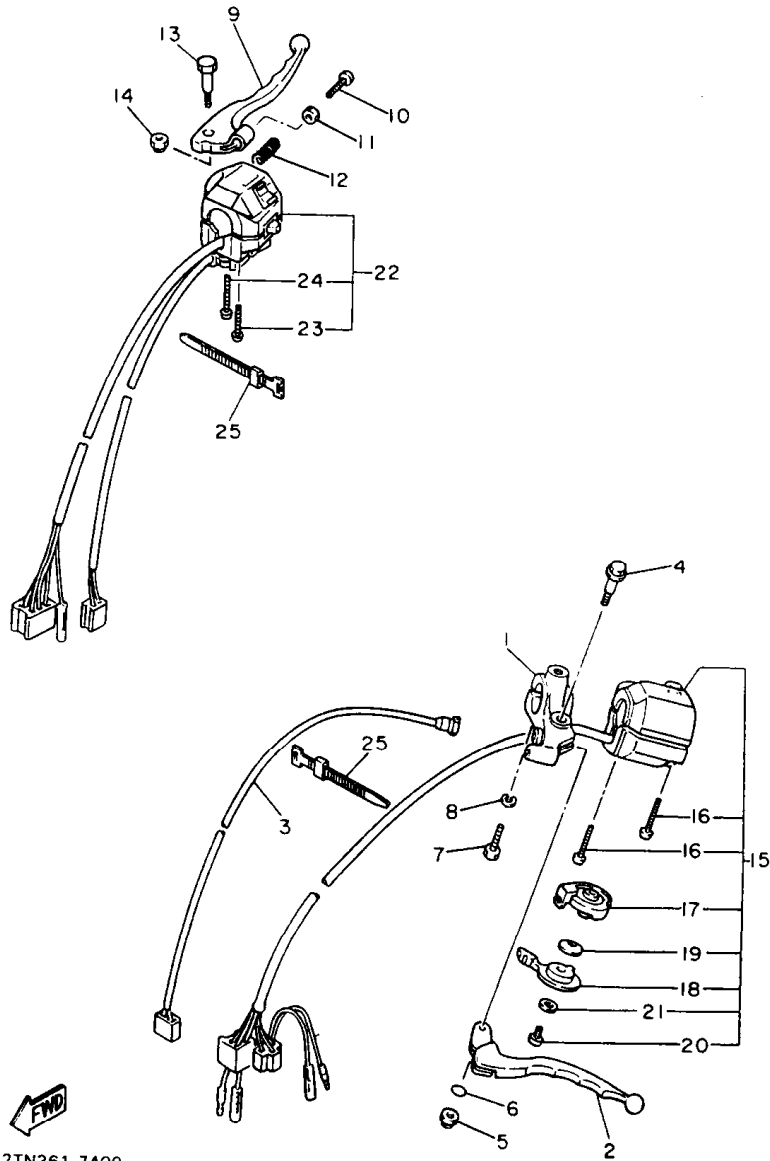

2TN361-7400

REF. NO.	PART NO.	DESCRIPTION	Q'TY	REMARKS
1	10M-82911-00	HOLDER, LEVER 1	1	
2	2GV-83912-00	LEVER 1	1	
3	3Y6-82917-00	SWITCH	1	
4	90109-06799	BOLT	1	
5	95607-06100	NUT, U	1	
6	93210-11368	O-RING	1	
7	97007-06025	BOLT	1	
8	92907-06100	WASHER	1	
9	2W1-83922-00	LEVER 2	1	
10	90149-06153	SCREW	1	
11	90170-06010	NUT	1	
12	90501-10312	SPRING, COMPRESSION	1	
13	90109-06577	BOLT	1	
14	95607-06100	NUT, U	1	
15	1AT-83972-00	SWITCH, HANDLE 4	1	
16	98507-05035	.SCREW, PAN HEAD	2	
17	10M-83942-00	.COVER, STARTER	1	
18	10M-83941-00	.LEVER, STARTER	1	
19	90209-10131	.WASHER	1	
20	98507-06008	.SCREW, PAN HEAD	1	
21	92907-06200	.WASHER	1	
22	3LP-83972-00	SWITCH, HANDLE 4	1	
23	98507-05040	.SCREW, PAN HEAD	1	
24	98507-05045	.SCREW, PAN HEAD	1	
25	437-83936-01	BAND, SWITCH CORD	4	

FIG. 41 ELECTRICAL 1

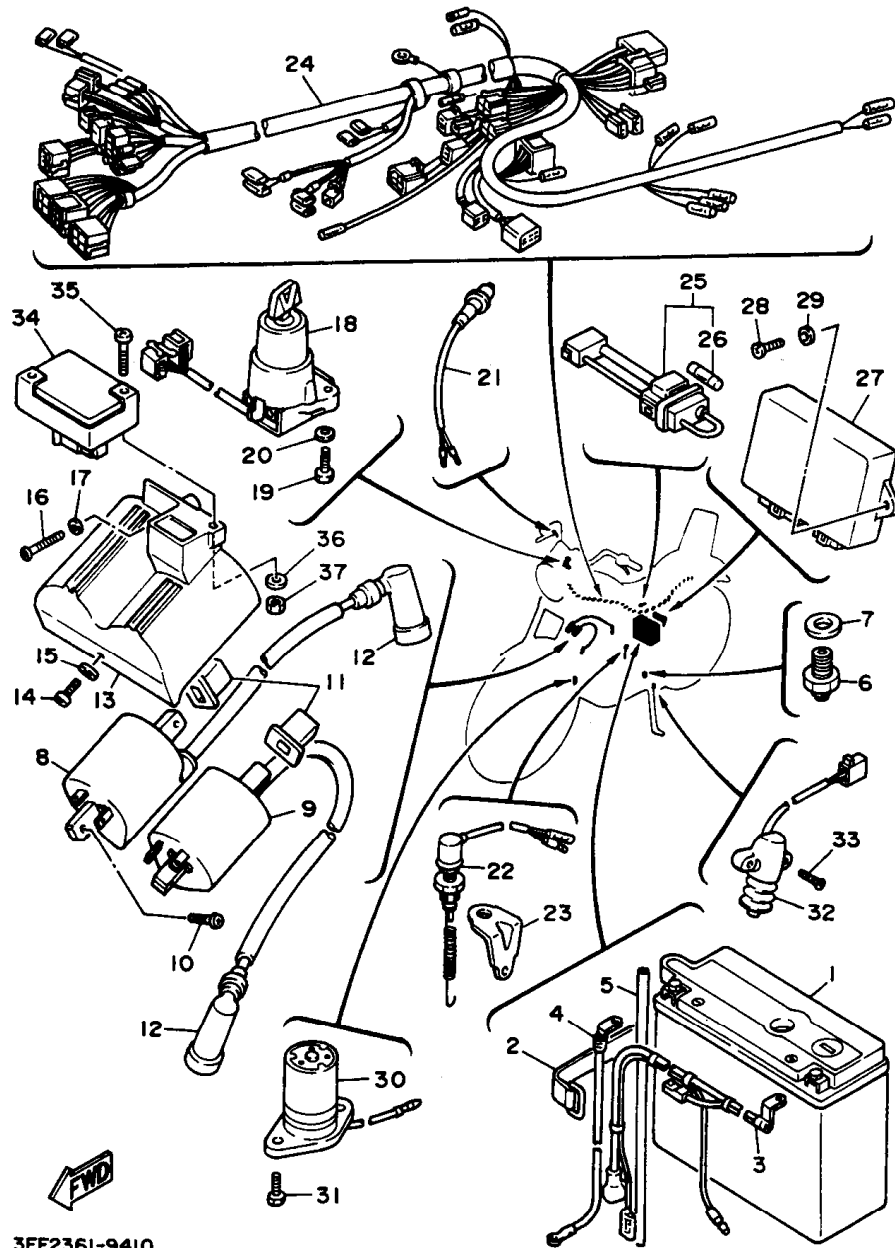

3EF2361-9410

REF. NO.	PART NO.	DESCRIPTION	Q'TY	REMARKS
1	11K-82110-79	BATTERY (YAMAHA FB50-N18L-A2)	1	
2	1E6-82131-00	BAND, BATTERY	1	
3	42H-82115-00	WIRE, PLUS LEAD	1	
4	42X-82116-00	WIRE, MINUS LEAD	1	
5	90445-081A9	HOSE	1	
6	4KM-82540-00	NEUTRAL SWITCH ASSY	1	
7	90430-10148	GASKET	1	
8	42X-82310-70	IGNITION COIL ASSY	1	
9	42X-82320-70	IGNITION COIL ASSY	1	
10	98980-05016	SCREW, BIND	2	
11	42X-82317-00	DAMPER, IGNITION COIL	2	
12	1J7-82370-00	PLUG CAP ASSY	2	
13	57A-82314-00	COVER, IGNITION COIL	1	
14	98507-06012	SCREW, PAN HEAD	1	
15	92907-06600	WASHER	1	
16	98507-06025	SCREW, PAN HEAD	1	
17	92907-06600	WASHER	1	
18	2AE-82510-00	MAIN SWITCH ASSY	1	
19	97017-06016	BOLT	2	
20	92907-06600	WASHER	2	
21	1A0-83980-30	FRONT STOP SWITCH ASSY	1	
22	42X-82530-02	STOP SWITCH ASSY	1	
23	42X-82539-00	STAY, STOP SWITCH	1	
24	3LP-82590-00	WIRE HARNESS ASSY	1	
25	3H5-82150-00	FUSE HOLDER ASSY	1	
26	2H7-82151-00	.FUSE (12V-30A)	2	
27	3JK-82305-00	IGNITOR UNIT ASSY	1	
28	97707-60520	SCREW, TAPPING	2	

F2

FIG. 41 ELECTRICAL 1

REF. NO.	PART NO.	DESCRIPTION	Q'TY	REMARKS
29	90201-063A5	WASHER, PLATE	2	
30	3JK-85720-00	OIL LEVEL GAUGE ASSY	1	
31	91317-06016	BOLT	2	
32	33E-82566-00	SWITCH, SIDE STAND	1	
33	90152-05021	SCREW, COUNTERSUNK	2	
34	1TA-82380-20	SENSOR, PRESSURE	1	
35	98517-06030	SCREW, PAN HEAD	1	
36	92907-06600	WASHER	1	
37	90170-06184	NUT	1	

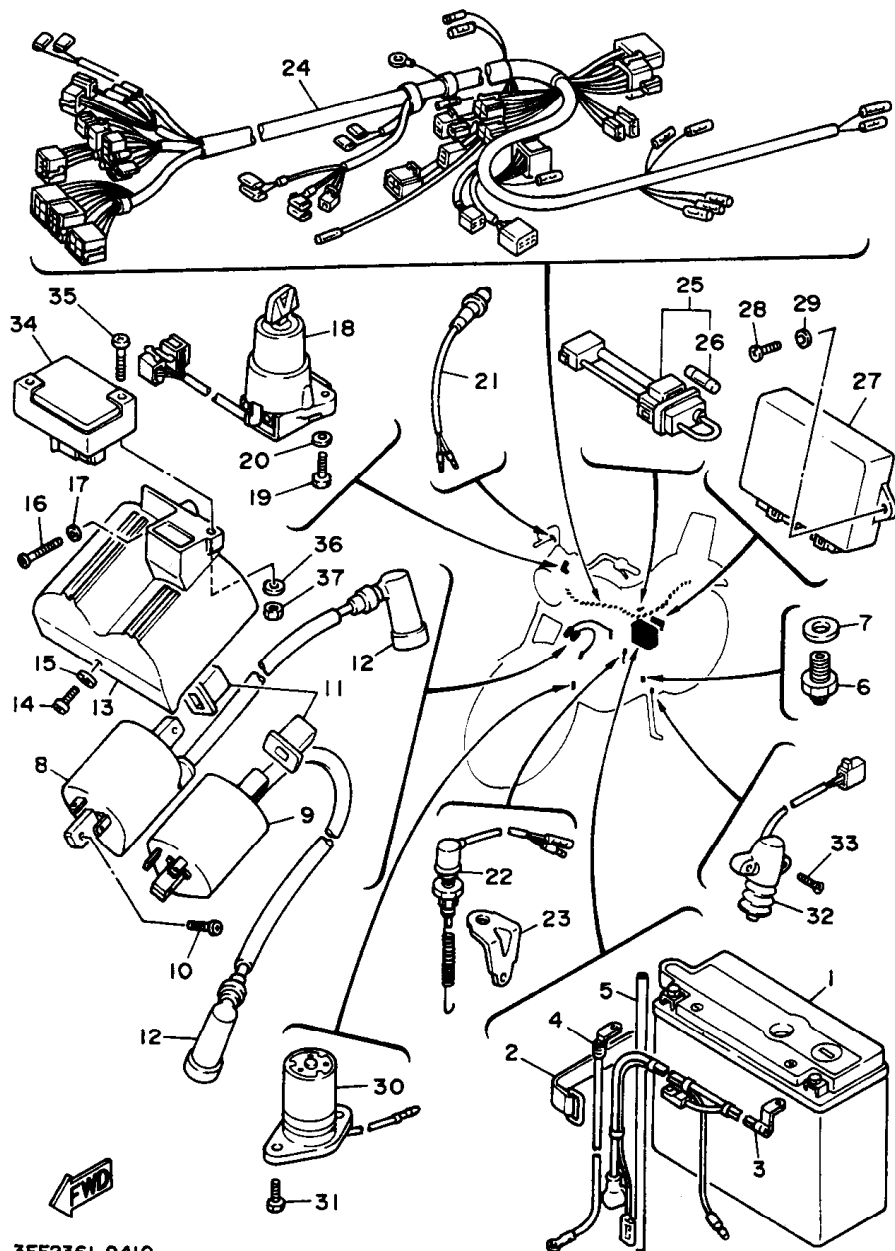

3EF236I-9410

F3

FIG. 42 ELECTRICAL 2

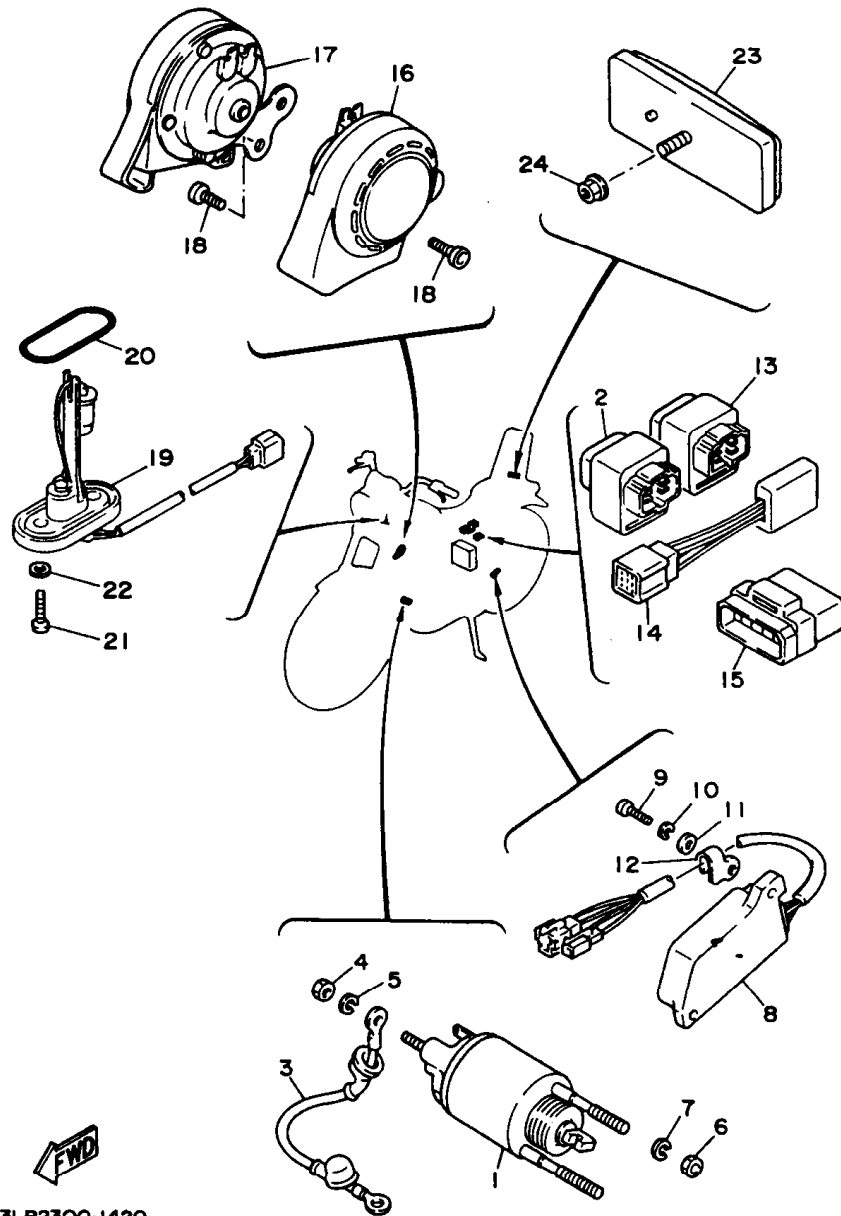

REF. NO.	PART NO.	DESCRIPTION	Q'TY	REMARKS
1	5A8-86110-50	SOLENOID	1	
2	25G-81950-01	RELAY ASSY	1	FOR FUEL PUMP
3	3JK-81815-00	CORD, STARTER MOTOR	1	
4	95307-06700	NUT	1	
5	92907-06100	WASHER, SPRING	1	
6	95307-08700	NUT	2	
7	92907-08100	WASHER, SPRING	2	
8	42X-81960-A1	RECTIFIER & REGULATOR ASSY	1	
9	98507-06016	SCREW, PAN HEAD	2	
10	92907-06100	WASHER, SPRING	2	
11	92907-06600	WASHER, PLATE	2	
12	90465-10264	CLAMP	1	
13	25G-81950-01	RELAY ASSY	1	FOR FUEL PUMP
14	4U8-81980-M0	RECTIFIER 2	1	FOR SIDE STAND SAFETY DEVICE
15	41R-83350-71	FLASHER RELAY ASSY	1	
16	1RM-83371-00	HORN	1	
17	1RM-83371-10	HORN	1	
18	91317-06012	BOLT	2	
19	42H-85752-01	SENDER UNIT ASSY, FUEL METER	1	
20	42X-85753-00	GASKET, SENDER UNIT	1	
21	90149-06011	SCREW	2	
22	90202-05187	WASHER, PLATE	2	
23	2EN-85130-00	REAR REFLECTOR ASSY	1	
24	95707-05500	NUT, FLANGE	1	

FWD
3LP2300-1420

INDIVIDUAL SPEC.

FOR ENGLAND (3LP9)

The following pages provides a listing of only the parts that meet the specifications peculiar to your market. For those parts not appearing in these pages, refer to the "GENERAL SPEC" section.

FIG. 43 ALTERNATE (CHASSIS)

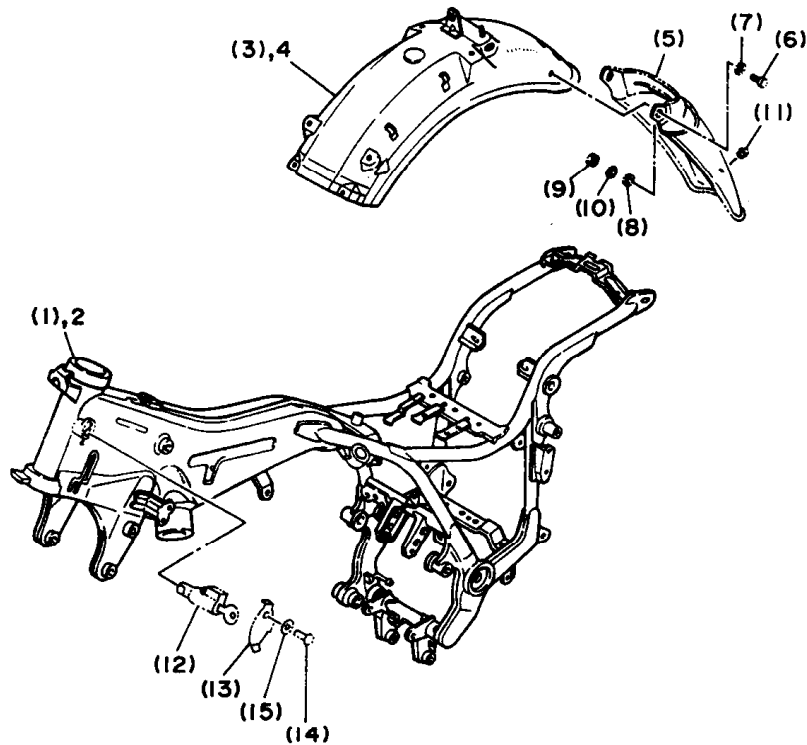

REF. NO.	PART NO.	DESCRIPTION	Q'TY	REMARKS
1	3LP-21110-00-33	FRAME COMP.	*	YAMAHA BLACK
2	3CF-21110-00-33	FRAME COMP.	1	YAMAHA BLACK
3	3EF-21610-00-P0	REAR FENDER COMP.	*	UR VERY DARK MAGENTA COCKTAIL 1
	3EF-Y2161-80-JW	REAR FENDER COMP.	*	UR URUSHI BLACK
4	1RM-21610-01-P2	REAR FENDER COMP.	1	UR VERY DARK MAGENTA COCKTAIL 1
	1RM-Y2161-R1-JW	REAR FENDER COMP.	1	UR URUSHI BLACK
5	3EF-21621-00	FLAP	*	
6	98517-06012	SCREW, PAN HEAD	*	
7	92907-06600	WASHER	*	
8	90202-05187	WASHER, PLATE	*	
9	95317-06600	NUT	*	
10	92907-06200	WASHER	*	
11	4G0-21639-00	DAMPER 2	*	
12	*	STEERING LOCK ASSY	*	LM
13	134-23484-10	CAP, HANDLE LOCK	*	
14	90269-04003	RIVET	*	
15	90208-04029	WASHER, CONICAL SPRING	*	

* For convenience of reference:

Disregard the items asterisked (*) in the "QTY" column. These are intended for GENERAL SPEC, and NOT for INDIVIDUAL SPEC.



3LP7300-4430

F6

FIG. 44 ALTERNATE (ELECTRICAL)

REF. NO.	PART NO.	DESCRIPTION	Q'TY	REMARKS
1	1FL-83570-F0	SPEEDOMETER ASSY	*	
2	3LP-83570-00	SPEEDOMETER ASSY	1	
3	2AE-84320-G0	LENS ASSY	*	
4	55R-84321-H0	LENS ASSY	1	
5	*	BULB (12V-4W)	* LM	
6	*	BULB (12V-3.4W)	1 LM	
7	2AE-82510-00	MAIN SWITCH ASSY	*	
8	2AE-82501-01	MAIN SWITCH STEERING LOCK	1	
9	92907-06600	WASHER, PLATE	*	
10	95307-06600	NUT	*	

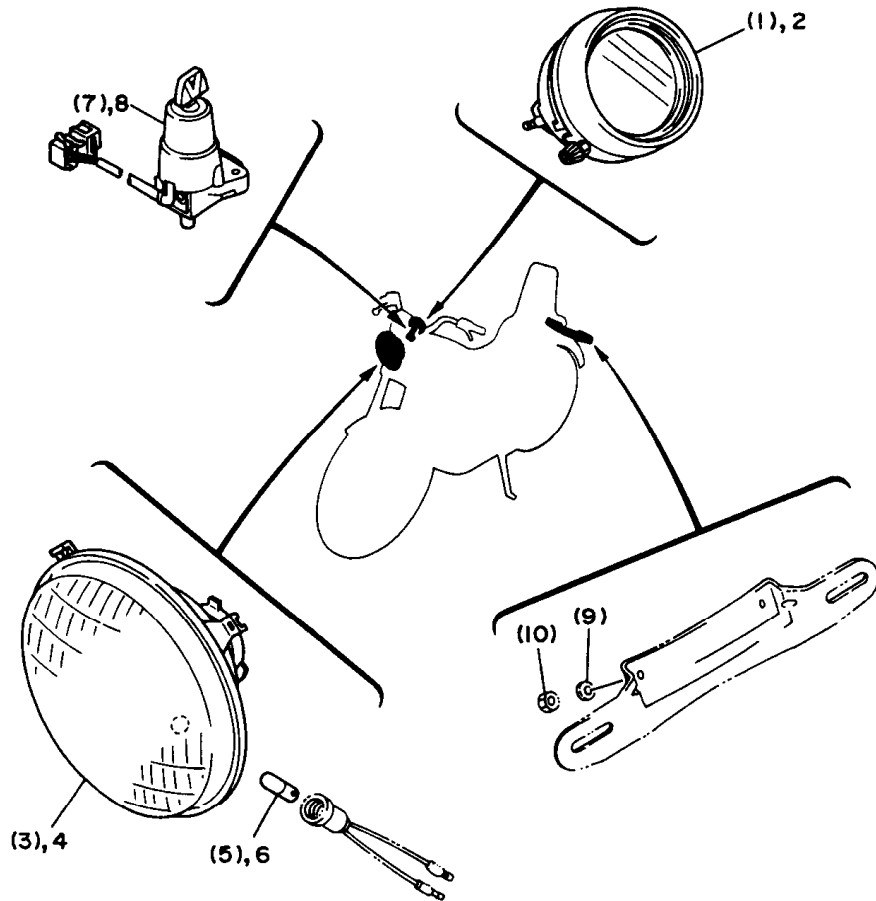

3LP2300-1440

* For convenience of reference:

Disregard the items asterisked (*) in the "QTY" column. These are intended for GENERAL SPEC, and NOT for INDIVIDUAL SPEC.

F7

FOR BELGIUM (3LP9)

FOR ITALY (3LP9)

FOR SPAIN (3LPA)

FOR BRAZIL (3LPA)

The following pages provides a listing of only the parts that meet the specifications peculiar to your market. For those parts not appearing in these pages, refer to the "GENERAL SPEC" section.

FIG. 45 ALTERNATE (CHASSIS)

REF. NO.	PART NO.	DESCRIPTION	Q'TY	REMARKS
1	3LP-21110-00-33	FRAME COMP.	*	YAMAHA BLACK
2	3CF-21110-00-33	FRAME COMP.	1	YAMAHA BLACK
3	3EF-21610-00-P0	REAR FENDER COMP.	*	UR VERY DARK MAGENTA COCKTAIL 1
	● 3EF-Y2161-80-JW	REAR FENDER COMP.	*	UR URUSHI BLACK
4	1RM-21610-01-P2	REAR FENDER COMP.	1	UR VERY DARK MAGENTA COCKTAIL 1
	1RM-Y2161-R1-JW	REAR FENDER COMP.	1	UR URUSHI BLACK
5	3EF-21621-00	FLAP	*	
6	98517-06012	SCREW, PAN HEAD	*	
7	92907-06600	WASHER	*	
8	90202-05187	WASHER, PLATE	*	
9	95317-06600	NUT	*	
10	92907-06200	WASHER	*	
11	4G0-21639-00	DAMPER 2	*	
12	*	STEERING LOCK ASSY	*	LM
13	134-23484-10	CAP, HANDLE LOCK	*	
14	90269-04003	RIVET	*	
15	90208-04029	WASHER, CONICAL SPRING	*	

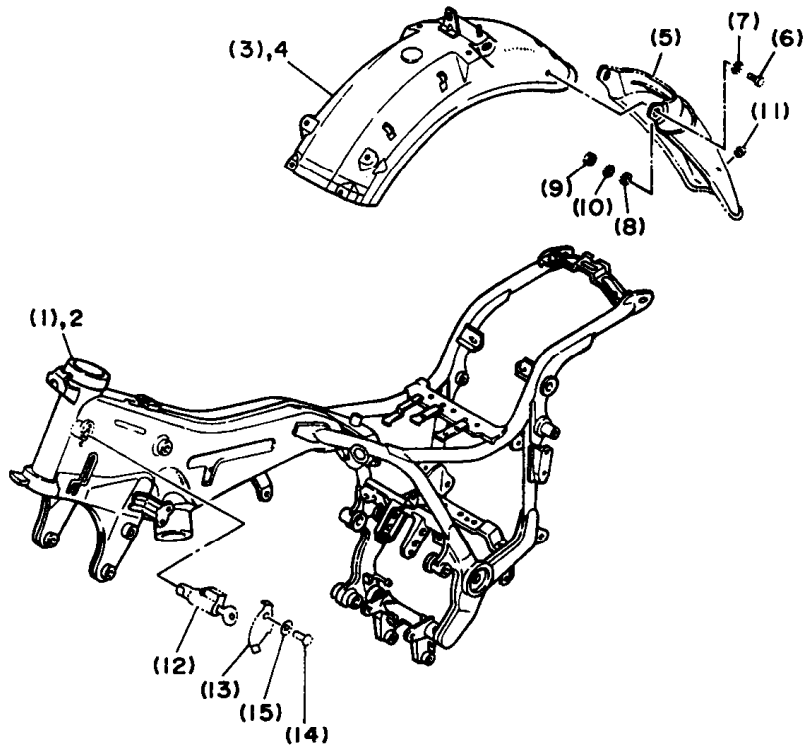

3LP7300-4430

* For convenience of reference:

Disregard the items asterisked (*) in the "QTY" column. These are intended for GENERAL SPEC, and NOT for INDIVIDUAL SPEC.

F9

FIG. 46 ALTERNATE (ELECTRICAL)

REF. NO.	PART NO.	DESCRIPTION	QTY	REMARKS
1	1RM-83371-00	HORN	*	
2	2AE-83371-01	HORN	1	
3	1RM-83371-10	HORN	*	
4	2AE-83371-11	HORN	1	
5	2AE-83378-00	STAY, HORN	1	
6	2AE-83378-10	STAY, HORN	1	
7	97007-08012	BOLT	2	
8	92907-08100	WASHER	2	
9	92907-08600	WASHER	2	
10	2AE-82510-00	MAIN SWITCH ASSY	*	
11	2AE-82501-01	MAIN SWITCH STEERING LOCK	1	
12	92907-06600	WASHER, PLATE	*	
13	95307-06600	NUT	*	

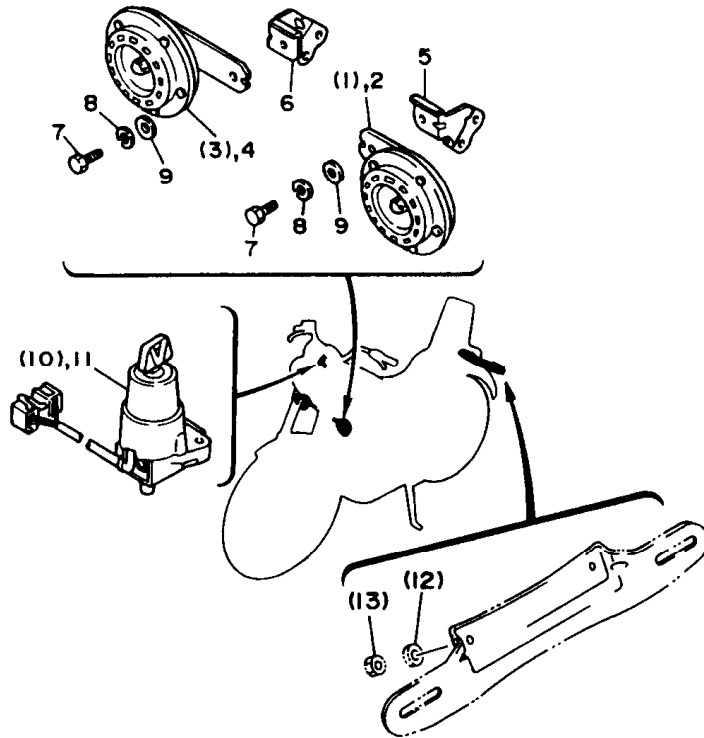

3LP2300-1460

* For convenience of reference:

Disregard the items asterisked (*) in the "QTY" column. These are intended for GENERAL SPEC, and NOT for INDIVIDUAL SPEC.

F10

FOR PORTUGAL (3LP9)

FOR GREECE (3LP9)

FOR NETHERLAND (3LP9)

The following pages provides a listing of only the parts that meet the specifications peculiar to your market. For those parts not appearing in these pages, refer to the "GENERAL SPEC" section.

FIG. 47 ALTERNATE (CHASSIS)

REF. NO.	PART NO.	DESCRIPTION	Q'TY	REMARKS
1	3EF-21610-00-P0	REAR FENDER COMP.	*	UR VERY DARK MAGENTA COCKTAIL 1
	3EF-Y2161-80-JW	REAR FENDER COMP.	*	UR URUSHI BLACK
2	1RM-21610-01-P2	REAR FENDER COMP.	1	UR VERY DARK MAGENTA COCKTAIL 1
	1RM-Y2161-R1-JW	REAR FENDER COMP.	1	UR URUSHI BLACK
3	3EF-21621-00	FLAP	*	
4	98517-06012	SCREW, PAN HEAD	*	
5	92907-06600	WASHER	*	
6	90202-05187	WASHER, PLATE	*	
7	95317-06600	NUT	*	
8	92907-06200	WASHER	*	
9	4G0-21639-00	DAMPER 2	*	

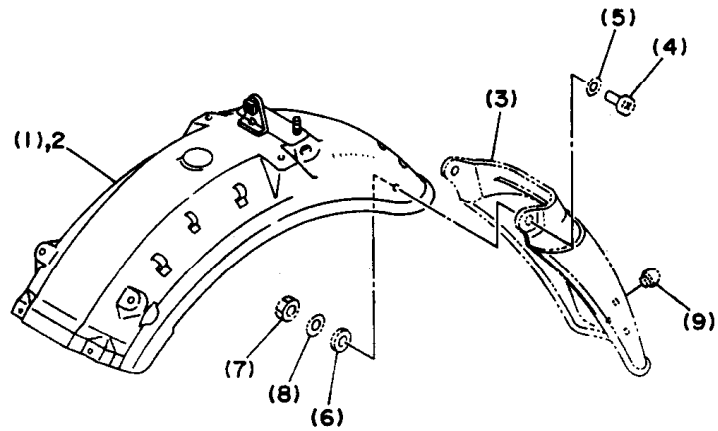

3LP7300-4470

* For convenience of reference:

Disregard the items asterisked (*) in the "QTY" column. These are intended for GENERAL SPEC, and NOT for INDIVIDUAL SPEC.

F12

FIG. 48 ALTERNATE (ELECTRICAL)

REF. NO.	PART NO.	DESCRIPTION	Q'TY	REMARKS
1	1RM-83371-00	HORN	*	
2	2AE-83371-01	HORN	1	
3	1RM-83371-10	HORN	*	
4	2AE-83371-11	HORN	1	
5	2AE-83378-00	STAY, HORN	1	
6	2AE-83378-10	STAY, HORN	1	
7	97007-08012	BOLT	2	
8	92907-08100	WASHER	2	
9	92907-08600	WASHER	2	
10	92907-06600	WASHER, PLATE	*	
11	95307-06600	NUT	*	

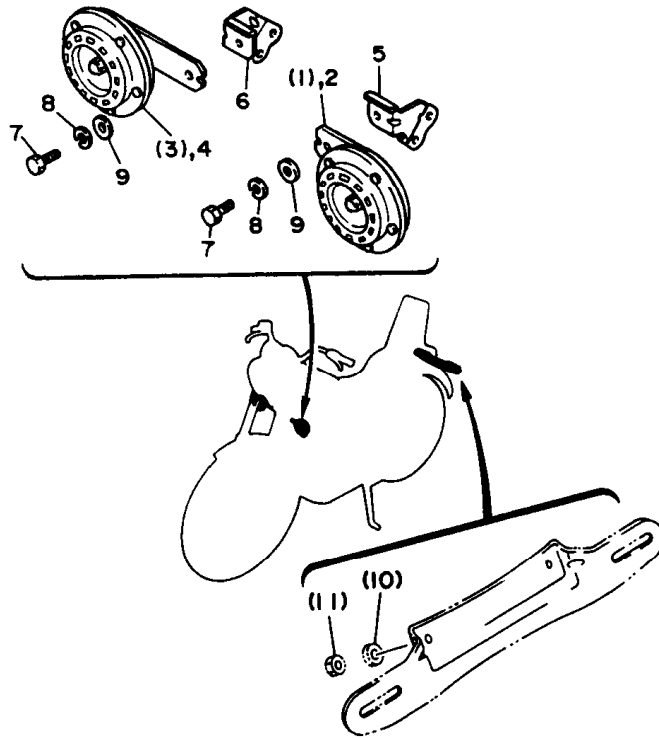

3LP4300-2510

* For convenience of reference:

Disregard the items asterisked (*) in the "QTY" column. These are intended for GENERAL SPEC, and NOT for INDIVIDUAL SPEC.

F13

FOR SWITZERLAND (3EF6)

FOR AUSTRIA (3EF6)

The following pages provides a listing of only the parts that meet the specifications peculiar to your market. For those parts not appearing in these pages, refer to the "GENERAL SPEC" section.

FIG. 49 ALTERNATE (ENGINE 1)

REF. NO.	PART NO.	DESCRIPTION	Q'TY	REMARKS
1	1TF-11102-01	CYLINDER HEAD ASSY	*	
2	1TA-11102-01	CYLINDER HEAD ASSY	2	
3	42H-14873-01	PIPE 3	2	
4	1TA-13534-00	HOSE, VACUUM SENSING 5	1	
5	90467-08092	CLIP	2	
6	1TA-13535-00	HOSE, VACUUM SENSING 5	1	
7	41R-14489-00	NOZZLE	1	

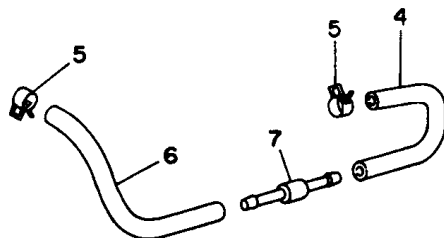
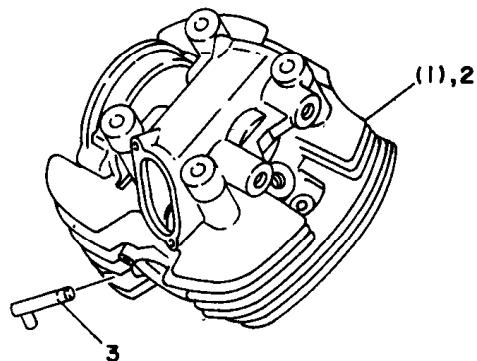

3LP4300-2520

* For convenience of reference:

Disregard the items asterisked (*) in the "QTY" column. These are intended for GENERAL SPEC, and NOT for INDIVIDUAL SPEC.

F15

FIG. 50 ALTERNATE (ENGINE 2)

REF. NO.	PART NO.	DESCRIPTION	QTY	REMARKS
1	3LP-14900-01	CABURETOR ASSY	*	
2	3EF-14900-11	CABURETOR ASSY	1	
3	3LP-14901-01	.CARBURETOR ASSY 1	*	
4	3EF-14901-11	.CARBURETOR ASSY 1	1	
5	3LP-14902-01	.CARBURETOR ASSY 2	*	
6	3EF-14902-11	.CARBURETOR ASSY 2	1	
7	22F-14991-00	..CAP	*	
8	2RJ-14118-00	..CAP	1	
9	4G0-14142-40	..JET, PILOT (# 40)	*	
10	4G0-14142-37-A0	..JET, PILOT (#37.5)	1	

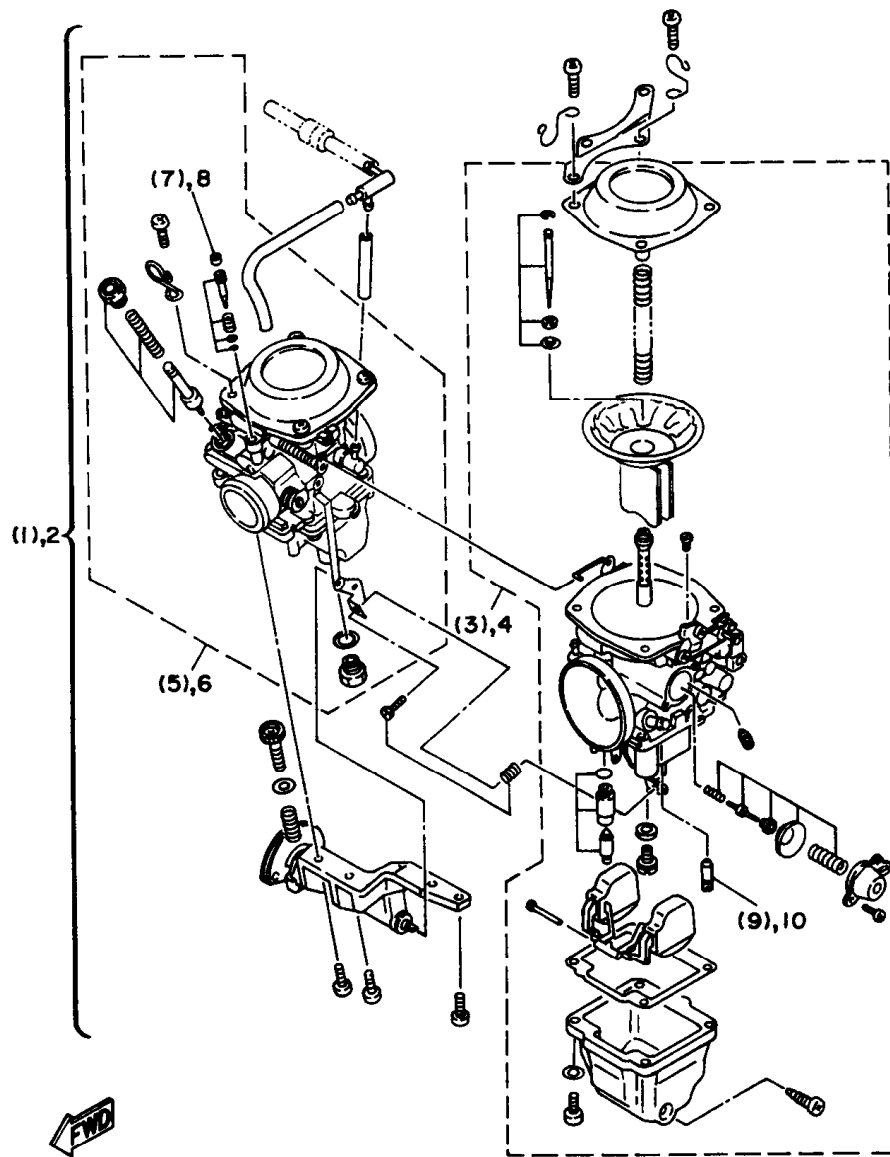

3LP7300-4500

* For convenience of reference:

Disregard the items asterisked (*) in the "QTY" column. These are intended for GENERAL SPEC, and NOT for INDIVIDUAL SPEC.

G2

FIG. 51 ALTERNATE (ENGINE 3)

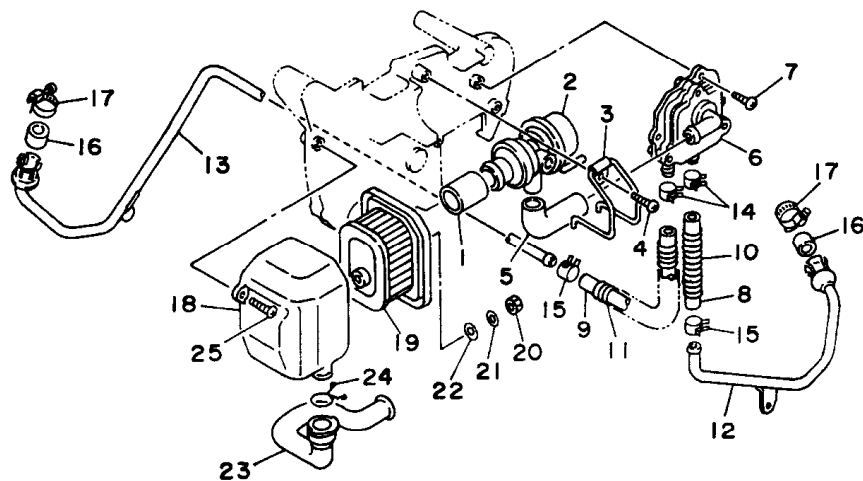

REF. NO.	PART NO.	DESCRIPTION	Q'TY	REMARKS
1	42H-14882-00	HOSE, BEND 2	1	
2	1TA-14840-00	AIR CUT VALVE ASSY	1	
3	90462-20188	CLAMP	1	
4	97707-60114	SCREW, TAPPING	1	
5	42H-14883-00	HOSE, BEND 3	1	
6	42H-14808-00	REED VALVE ASSY	1	
7	97707-60114	SCREW, TAPPING	3	
8	42H-14884-00	HOSE, BEND 4	1	
9	42H-14885-00	HOSE, BEND 5	1	
10	90501-101J3	SPRING, COMPRESSION	1	
11	90501-101J4	SPRING, COMPRESSION	1	
12	42H-14871-01	PIPE 1	1	
13	42H-14872-02	PIPE 2	1	
14	90468-08104	CLIP	2	
15	90467-16098	CLIP	2	
16	42H-14714-10	GASKET, MUFFLER	2	
17	90460-15227	CLAMP, HOSE	2	
18	42H-14857-00	CASE, AIR CLEANER	1	
19	42H-14858-00	CAP, CASE	1	
20	95380-05600	NUT	1	
21	92990-05200	WASHER, PLAIN	1	
22	90202-05057	WASHER, PLATE	1	
23	1TA-14881-00	HOSE, BEND 1	1	
24	90467-22080	CLIP	1	
25	97707-60114	SCREW, TAPPING	1	



3LP4300-2540

G3

FIG. 52 ALTERNATE (CHASSIS 1)

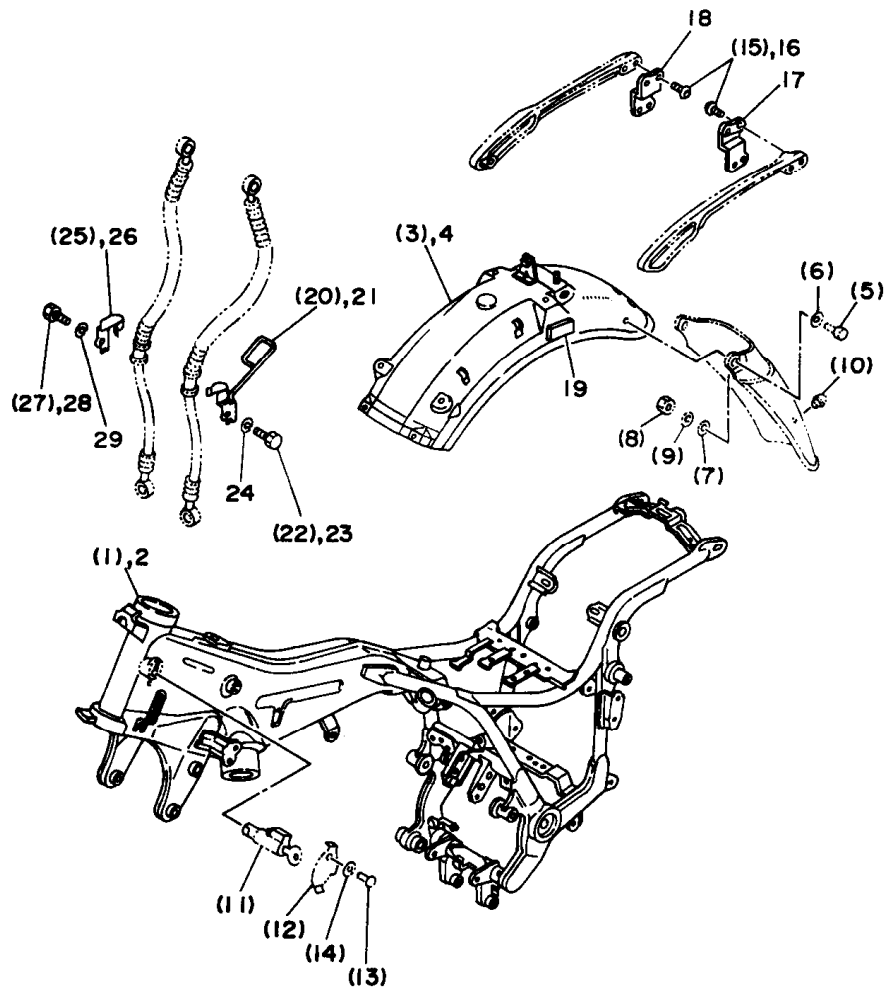

REF. NO.	PART NO.	DESCRIPTION	Q'TY	REMARKS	
1	3LP-21110-00-33	FRAME COMP.	*	YAMAHA BLACK	
2	3CF-21110-00-33	FRAME COMP.	1	YAMAHA BLACK	
3	3EF-21610-00-P0	REAR FENDER COMP.	*	UR VERY DARK MAGENTA COCKTAIL 1 AUSTRIA ONLY	
	3EF-Y2161-80-JW	REAR FENDER COMP.	*	UR URUSHI BLACK AUSTRIA ONLY	
4	1RM-21610-01-P2	REAR FENDER COMP.	1	UR VERY DARK MAGENTA COCKTAIL 1 AUSTRIA ONLY	
	1RM-Y2161-R1-JW	REAR FENDER COMP.	1	UR URUSHI BLACK AUSTRIA ONLY	
5	98517-06012	SCREW, PAN HEAD	*	AUSTRIA ONLY	
6	92907-06600	WASHER	*		
7	90202-05187	WASHER, PLATE	*		
8	95317-06600	NUT	*		
9	92907-06200	WASHER	*		
10	4G0-21639-00	DAMPER 2	*		
11	*	STEERING LOCK ASSY	*		LM
12	134-23484-10	CAP, HANDLE LOCK	*		
13	90269-04003	RIVET	*		
14	90208-04029	WASHER, CONICAL SPRING	*		
15	95817-06016	BOLT, FLANGE	*	AUSTRIA ONLY	
16	92017-06020	BOLT, BUTTON HEAD	4		
17	4GK-21688-00	BRACKET, REAR STAY	1		
18	4GK-21689-00	BRACKET, REAR STAY 2	1		
19	1JK-21735-00	SEAL 2	2		
20	55R-25875-00	HOLDER, BRAKE HOSE 1	*		
21	42X-25875-00	HOLDER, BRAKE HOSE 1	1		
22	95024-06020	BOLT, FLANGE	*		
23	97007-06010	BOLT	1		
24	92907-06100	WASHER, SPRING	1		
25	55R-25876-00	HOLDER, BRAKE HOSE 2	*		
26	42X-25876-00	HOLDER, BRAKE HOSE 2	1		



4FY4300-4520

G4

FIG. 52 ALTERNATE (CHASSIS 1)

REF. NO.	PART NO.	DESCRIPTION	Q'TY	REMARKS
27	95024-06020	BOLT, FLANGE	*	} AUSTRIA ONLY
28	97007-06010	BOLT	1	
29	92907-06100	WASHER, SPRING	1	

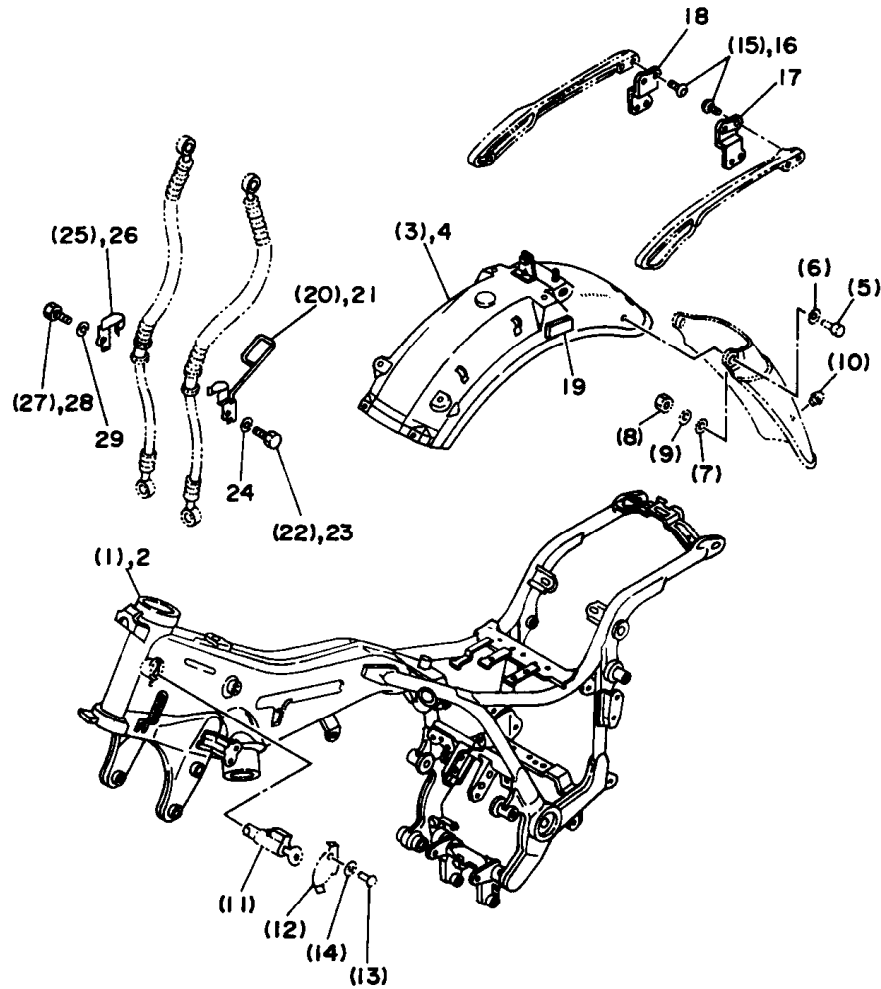

4FY4300-4520

* For convenience of reference:

Disregard the items asterisked (*) in the "QTY" column. These are intended for GENERAL SPEC, and NOT for INDIVIDUAL SPEC.

G5

FIG. 53 ALTERNATE (CHASSIS 2)

REF. NO.	PART NO.	DESCRIPTION	Q'TY	REMARKS
1	3CF-W2611-10	HANDLEBAR	*	
2	3CF-W2611-00	HANDLEBAR	1	
3	3JB-26241-00	GRIP (LEFT)	*	
4	42X-26241-00	GRIP (LEFT)	1	
5	3JB-26273-00	ROTOR	*	
6	26H-2628J-00	CAP, GRIP	1	
7	3JB-26240-00	GRIP ASSY	*	
8	1FK-26240-00	GRIP ASSY	1	
9	3JB-2628J-00	CAP, GRIP	*	
10	26H-2628J-00	CAP, GRIP	1	

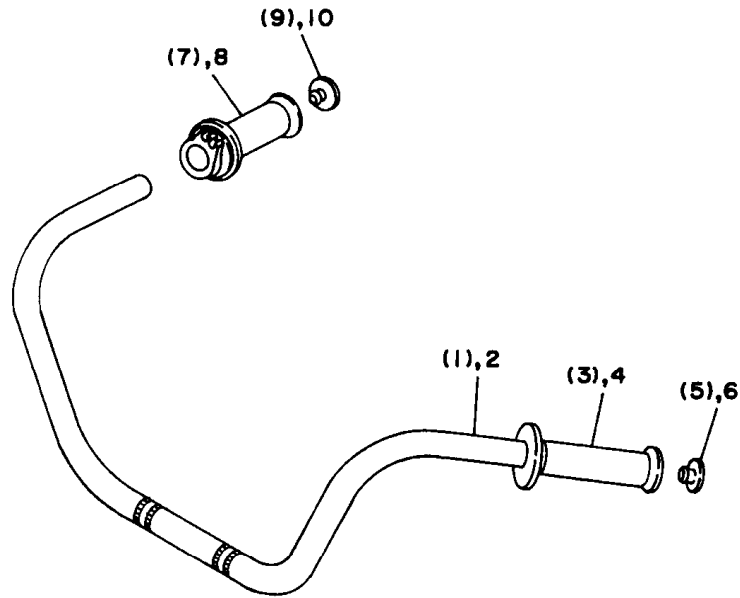

3LP4300-2550

* For convenience of reference:

Disregard the items asterisked (*) in the "QTY" column. These are intended for GENERAL SPEC, and NOT for INDIVIDUAL SPEC.

G6

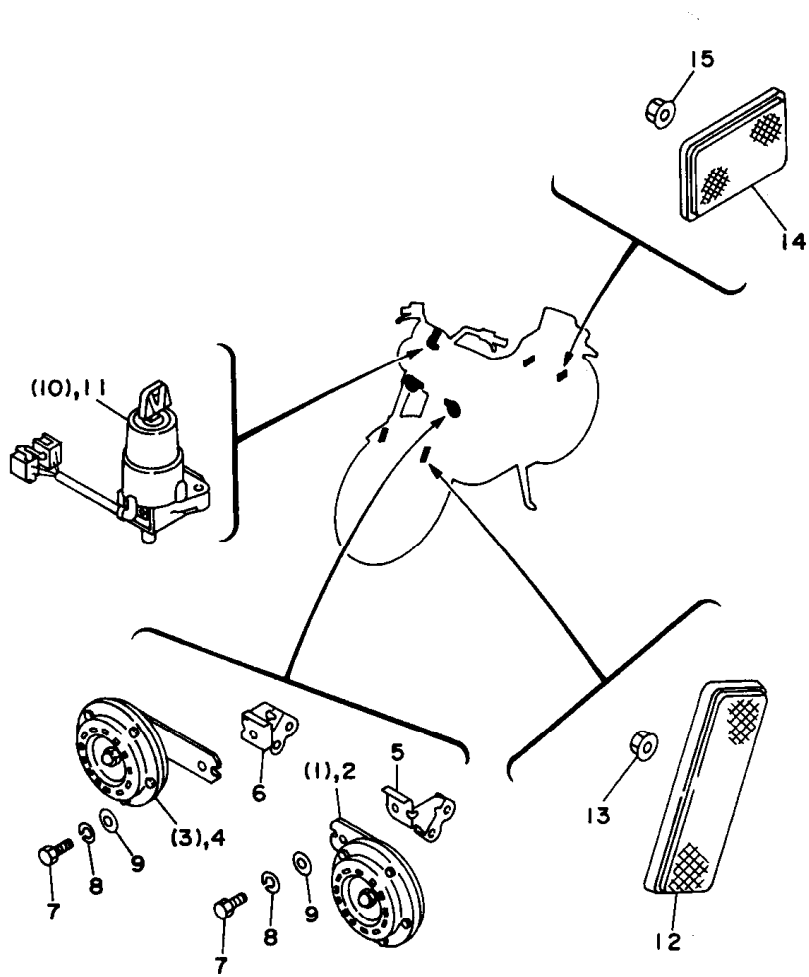

FIG. 54 ALTERNATE (ELECTRICAL)

REF. NO.	PART NO.	DESCRIPTION	Q'TY	REMARKS
1	1RM-83371-00	HORN	*	
2	2AE-83371-01	HORN	1	UR FOR SWITZERLAND
	4GK-83371-00	HORN	1	UR FOR AUSTRIA
3	1RM-83371-10	HORN	*	
4	2AE-83371-11	HORN	1	UR FOR SWITZERLAND
	4GK-83371-10	HORN	1	UR FOR AUSTRIA
5	2AE-83378-00	STAY, HORN	1	
6	2AE-83378-10	STAY, HORN	1	
7	97007-08012	BOLT	2	
8	92907-08100	WASHER	2	
9	92907-08600	WASHER	2	
10	2AE-82510-00	MAIN SWITCH ASSY	*	
11	2AE-82501-01	MAIN SWITCH STEERING LOCK	1	
12	11H-85110-01	REFLECTOR ASSY	2	AUSTRIA ONLY
13	95707-05500	NUT, FLANGE	2	
14	20G-85110-00	REFLECTOR ASSY	2	
15	95707-05500	NUT, FLANGE	2	

FWD
4FY4300-4530

* For convenience of reference:
Disregard the items asterisked (*) in the "QTY" column. These are intended for GENERAL SPEC, and NOT for INDIVIDUAL SPEC.



FOR NORWAY (3LP9)

FOR FINLAND (3LP9)

FOR TURKEY (3LP9)

The following pages provides a listing of only the parts that meet the specifications peculiar to your market. For those parts not appearing in these pages, refer to the "GENERAL SPEC" section.

FIG. 55 ALTERNATE (CHASSIS,ELECTRICAL)

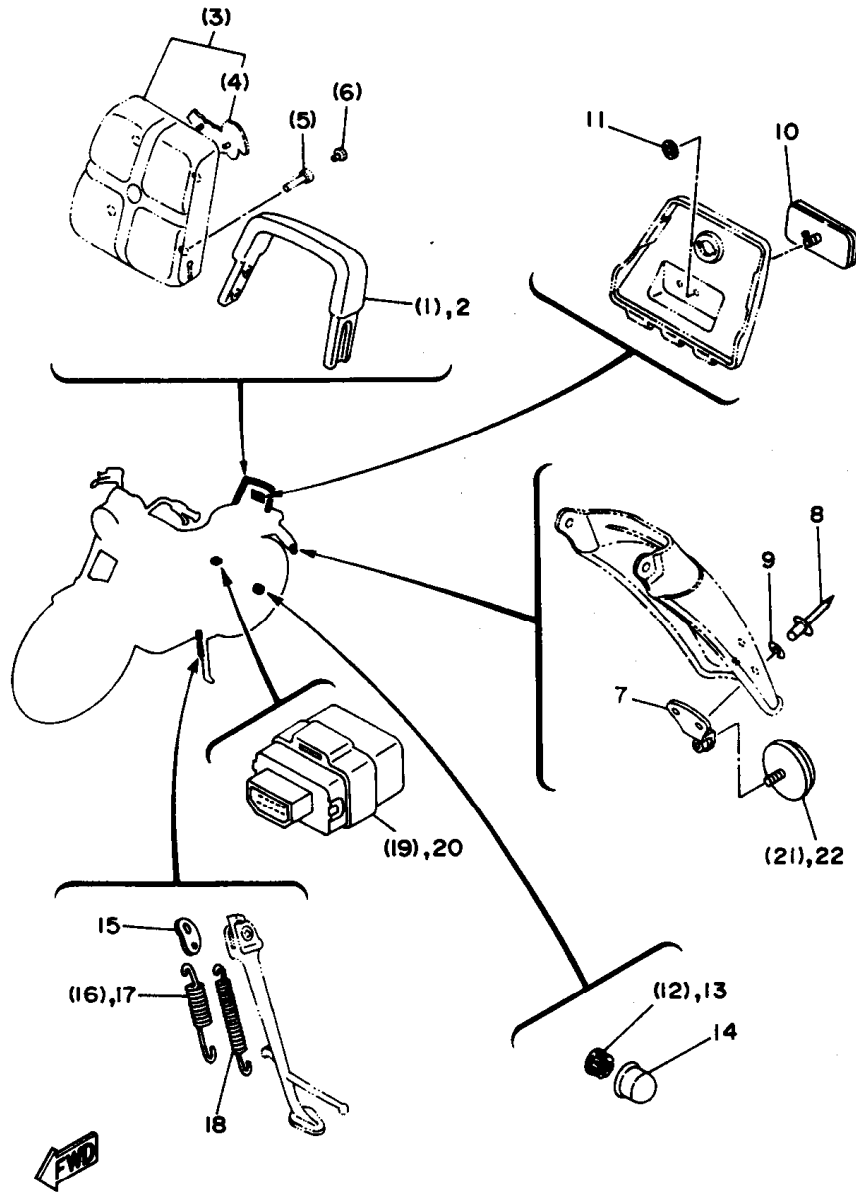

3LP7300-4550

REF. NO.	PART NO.	DESCRIPTION	Q'TY	REMARKS
1	42H-2164A-02	GRIP 1	*	
2	2AE-2164A-00	GRIP 1	1	
3	1TA-2840F-00	BACK REST ASSY	*	
4	42H-24786-00	.EMBLEM	*	
5	91317-06035	BOLT	*	
6	90338-06162	PLUG	*	
7	2AE-21641-00	BRACKET, REFLECTOR	1	
8	90267-40076	RIVET, BLIND	2	
9	90201-04018	WASHER, PLATE	2	
10	47G-85150-00	PANEL, SIDE	1	
11	90183-05003	NUT, SPRING	1	
12	90171-14044	NUT, CASTLE	*	
13	90171-14029	NUT, CASTLE	1	
14	4E7-25188-00	CAP	1	
15	3Y3-27315-00	LINK, SIDE STAND	1	
16	90507-29009	SPRING, TENSION	*	
17	90506-26225	SPRING, TENSION	1	
18	90506-18224	SPRING, TENSION	1	
19	41R-83350-71	FLASHER RELAY ASSY	*	
20	47G-83350-41	FLASHER RELAY ASSY	1	
21	2EN-85130-00	REAR REFLECTOR ASSY	*	
22	449-85131-02	REFLECTOR, REAR 1	1	

* For convenience of reference:

Disregard the items asterisked (*) in the "QTY" column. These are intended for GENERAL SPEC. and NOT for INDIVIDUAL SPEC.

G9

INDEX

(GENERAL SPEC.)

NUMERICAL INDEX

PART NO.	GRID NO.	PART NO.	GRID NO.	PART NO.	GRID NO.	PART NO.	GRID NO.	PART NO.	GRID NO.	PART NO.	GRID NO.
4K0-W0041-50	E- 5	1TA-11638-00	B- 5	42H-13532-00	B-11	57A-14612-01	C- 2	3LP-15524-10	C- 6	4X7-17554-00	C-10
3LP-W0045-00	D-15	5A8-11650-00	B- 5	3CG-13542-00	B-11	3EG-14613-00	C- 2	5A8-15542-01	C- 6	4X7-17556-00	C-10
	D-15	4X7-11654-01	B- 5	42X-13544-00	B-11	1TA-14621-00	C- 2	5A8-15550-00	C- 6	4X7-17558-00	C-10
3YX-W0047-50	D-15		B- 5	42X-13564-01	B-11	42X-14663-02	B-12	5A8-15556-00	C- 6	23W-17582-00	C- 9
	D-15	4X7-11656-00	B- 5	16G-13569-00	B-11	42X-1468A-00	C- 2	3EG-15568-00	C- 6	23W-17583-00	C- 9
51L-W0048-00	D-15	4X7-11656-10	B- 5		B-11	2TN-14711-01	C- 2	3LP-15570-00	C- 6	56W-17590-00	D- 7
	D-15	4X7-11656-20	B- 5	42X-13578-00	B-11	3EG-14714-00	C- 2	4X7-16111-00	C- 7	42X-18110-01	C-13
3YX-W0057-50	D-15	4X7-11656-30	B- 5	1TA-13586-00	B-11	42X-14748-01	C- 2	4X7-16150-02	C- 7	42X-18112-01	C-13
	D-15	4X7-11656-40	B- 5	24M-13586-01	B-11	3YF-14755-00	C- 2	3Y1-16154-00	C- 7	132-18113-01	C-13
3JK-W1542-01	C- 5	5G5-11656-00	B- 5	1TA-13595-00	B-11	48D-14766-00	C- 2	22U-16321-00	C- 7	29L-18115-00	C-13
42X-W2341-01-38	D- 8	5G5-11656-10	B- 5	42H-13907-00	B-11	42X-1479H-00	C- 2	4X7-16324-00	C- 7	4X7-18120-01	C-13
3DR-W2536-00	E- 2	5G5-11656-20	B- 6	42H-13971-00	B-11	3CF-1490H-00	B-14	1TA-16325-00	C- 8	4X7-18140-00	C-13
3CF-W2611-10	E- 4	5A8-11660-00	B- 5	3CF-1410A-00	B-14	3CN-1490J-00	B-14	1TA-16334-00	C- 8	2H9-18154-00	C-13
1TA-Y1757-00	C-10	2J2-12111-01	B- 7	3CF-14103-01	B-15	3CF-1490K-00	B-15	1TA-16335-00	C- 8		C-13
1MY-Y2151-40-5Y	D- 2	1TA-12113-00	B- 7	12R-14105-00	B-14	3LP-14900-01	B-14	4X7-16340-00	C- 7	4G0-18185-01	C-12
3EF-Y2161-80-JW	D- 2	1TA-12114-00	B- 7	3CF-14107-15	B-14	3LP-14901-01	B-14	2H7-16341-00	C- 7	4X7-18511-00	C-12
1TF-11102-01	B- 2	4X7-12116-00	B- 7	3CF-14141-93	B-14	3LP-14902-01	B-14	2H7-16343-00	C- 7	4X7-18512-00	C-12
4X7-1111F-00	B- 3	4X7-12117-00	B- 7	4G0-14142-40	B-14	3CF-14919-00	B-15	1TA-16351-00	C- 8	4X7-18513-00	C-12
42X-1111H-01	B- 2	4X7-12118-00	B- 7	137-14153-00	B-14	3CF-14933-00	B-14	1TA-16352-00	C- 8	4X7-18531-00	C-12
1RM-1112E-00	B- 3	341-12119-02	B- 7	2VA-14185-00	B-14	2JU-14937-00	B-14	4X7-16356-00	C- 7	4X7-18536-00	C-12
4X7-11127-00	B- 2	5A8-12121-00	B- 7	537-14186-00	B-14	3CF-14937-00	B-15	4X7-16357-00	C- 7	4X7-18540-01	C-12
4X7-11133-10	B- 2	42X-12151-00	B- 7	12R-14191-00	B-14	3CF-14940-00	B-14	1TA-16371-00	C- 7	136-18542-00	C-12
42X-11145-00	B- 8	4X7-12156-01	B- 7	3CF-14197-00	B-15	3CF-14984-01	B-14	4X7-16383-01	C- 7	3LP-21110-00-33	C-14
42X-11152-00	B- 2	4X7-12159-00	B- 7	3CG-14197-00	B-11	3CG-14987-00	B-11	4X7-16384-00	C- 7	42X-21164-00	C- 3
4X7-11161-00	B- 4	42H-12171-00	B- 8		B-15	22F-14991-00	B-14	4X7-16385-00	C- 7	42X-2117F-00	D- 4
42X-11165-00	B- 2	4X7-12176-00	B- 8	620-1423A-75	B-14	42H-15100-02	C- 3	2H7-16395-01	C- 7	42X-21171-00	D- 4
42X-11166-01	B- 2	42H-12181-00	B- 8	1HX-14231-28	B-14	2H7-15361-00	C- 4	2H7-16396-00	C- 7	26H-21308-00	D- 2
42H-11181-00	B- 2	4X7-12210-01	B- 8	3G2-14231-12	B-14	4X7-15361-00	C- 4	4X7-17121-00	C- 9	42X-21315-01	C-14
42X-11185-01	B- 2	4DW-12213-00	B- 4	620-14231-25-A0	B-14	57A-15363-11	C- 3	4X7-17141-00	C- 9	42X-21316-01	C-14
1L9-11186-00	C- 4		B- 8	3CF-14251-00	B-14	4X7-15388-00	C- 5	42X-17151-00	C- 9	42X-21317-00	C-14
42H-11186-01	B- 2	4X7-12215-00	B- 4	1TA-14348-00	B-11	1RM-15411-01	C- 4	1TA-17211-00	C- 9	42X-21359-00	C-14
4X7-11187-00	B- 2	4X7-12221-00	B- 8	1TA-14349-00	B-11	1RM-15415-01	C- 4	4X7-17221-00	C- 9	5H9-21376-00	D-13
214-11198-01	B- 9	4X7-12231-00	B- 8	3CG-14396-00	B-11	42X-15417-01	C- 4	4X7-17231-00	C- 9	2AE-2139R-00	C-14
	D- 7	4X7-12241-00	B- 8	42X-14401-01	B-12	1RM-15419-00	C- 4	4X7-17241-00	C- 9	42X-21458-01	C-14
1TA-11310-00	B- 4	4X7-12247-01	B- 8	10L-14407-00	B-12	3JK-15425-00	C- 4	42X-17251-00	C- 9	4X7-21485-00	C-14
3EG-11351-00	B- 4	1RM-13161-00	C- 5	1TA-1441A-00	B-12	3CG-15429-00	C- 4	4X7-17402-00	C- 9	1MY-21510-00-P2	D- 2
4X7-11363-01	B- 2	4X7-13171-00	B- 9	1TA-1441E-00	B-12	42X-15441-00	C- 4	1TA-17411-00	C- 9	4PW-21570-00	D- 2
1TA-11411-00	B- 5	10L-13300-00	B- 9	1TA-1441K-00	B-13	3EG-15451-00	C- 4	4X7-17524-00	C-10	3EF-21610-00-PO	D- 2
4X7-11534-00	B- 8	10L-13327-00	B- 9	1RM-14422-00	B-12	1RM-15455-00	C- 4	42X-17526-01	C-10	1RM-2162G-00	D-13
4X7-11536-00	B- 8	4X7-13354-00	B- 5	42X-14451-00	B-12	3EG-15459-00	C- 4	31A-17527-00	C-10	3EF-21621-00	D- 3
4X7-11540-02	B- 8	4X7-13355-00	B- 9	42X-14452-00	B-12	3EG-15462-00	C- 5	3H5-17529-00	C-10	42X-21629-00	D- 2
4X7-11550-01	B- 8	4X7-13405-00	B- 9	10L-14453-01	B-12	4X7-15484-00	B- 9	4X7-17531-00-15	C-10	4G0-21639-00	D- 3
1TA-11610-00	B- 5	1RM-13406-00	B- 9	42X-14477-00	B-12	4X7-15485-01	B- 9	4X7-17531-00-30	C-10	42H-2164A-02	D- 2
1TA-11610-20	B- 5	4X7-13419-00	C- 3	12R-14484-01	B-13		B- 9	4X7-17531-00-50	C-10	1RM-2164F-00	D- 2
1TA-11610-40	B- 5	4X7-13440-90	B-10	42X-14484-00	B-13	4X7-15491-00	C- 3	1J7-17537-Y0-30	D- 6	1RM-2164G-00	D- 2
1TA-11631-00-A0	B- 5	1RM-13447-00	B-10	42X-14485-00	B-12	1TA-15512-00	C- 6	1J7-17537-Y0-40	D- 6	3JK-2164H-00	D- 2
5A8-11633-00	B- 5	3JL-13455-00	B- 9	1RM-14603-00	B-13	3LP-15517-10	C- 6	1J7-17537-Y0-50	D- 6	3JK-2164J-00	D- 2
1TA-11636-00	B- 5	11H-13490-00	B-10	42H-14611-00	C- 2	4X7-15521-00	C- 6	11H-17551-00	C-10	4PW-21675-00	D- 2

NUMERICAL INDEX

PART NO.	GRID NO.	PART NO.	GRID NO.	PART NO.	GRID NO.	PART NO.	GRID NO.	PART NO.	GRID NO.	PART NO.	GRID NO.
5A8-21708-00	D-13	4Y2-23146-L0	D- 9	1FK-24560-00	D-12	3LP-25872-11	E- 5	1TA-2840F-00	D- 2	2AE-82510-00	F- 2
42X-21711-00-JW	D- 4		D-10	4X7-24602-04	D-11	3LP-25873-10	E- 5	56W-46101-02	D- 6	42X-82530-02	F- 2
42X-21711-00-P2	D- 4	4FY-23149-00	D- 9	4X7-24612-00	D-11	3LP-25874-10	E- 5	1J7-46117-Y0-30	D- 6	42X-82539-00	F- 2
466-21717-00	D- 4		D-10	3CF-24723-00	D-13	55R-25875-00	E- 5	1J7-46117-Y0-40	D- 6	4KM-82540-00	F- 2
42X-2172W-02	D- 4	3R4-23153-00	D- 9	509-24724-00	D-13	55R-25876-00	E- 5	1J7-46117-Y0-50	D- 6	33E-82566-00	F- 3
42X-21721-00-JW	D- 4		D- 9	42X-2473R-00	D-13	42H-25885-01	E- 5	22U-46118-00-12	D- 6	3LP-82590-00	F- 2
42X-21721-00-P2	D- 4	509-23158-L0	D- 9	42X-2473T-00	D-13	3YX-25919-00	D-15	22U-46118-00-14	D- 6	10M-82911-00	E-15
42X-2176E-00	D- 4		D-10	3CF-24730-10	D-13		D-15	22U-46118-00-16	D- 6	3Y6-82917-00	E-15
42X-2177K-00	D-13	42H-23168-00	D- 9	3CF-24731-10	D-13	3YX-25929-00	D-15	22U-46118-00-18	D- 6	2EN-83310-00	E-11
42X-21781-00	D- 4		D-10	1L9-2474-00	D-13		D-15	22U-46118-00-20	D- 7	1KT-83311-00	E-11
42X-21782-00	D- 4	1RM-2317E-00	D- 8	42H-24786-00	D- 2	3YX-25937-00	D-15	2H7-46122-00	D- 6	E-11	
1RM-22110-00-35	D- 5	33M-23170-00	D- 9	3LP-25104-00	D-14		D-15	4H7-46123-01	D- 6	2AE-83312-00	E-11
1J7-22141-00	D- 5		D-10	3LP-25111-00-35	D-14	5R2-25937-00	D-15	4H7-46125-00	D- 6	42X-83312-00	E-11
42X-22141-00	D- 5	42H-23170-00	D- 9	56W-2512A-00	D-14		D-15	1J7-46129-Y1	C-10	42X-83313-00	E-11
1J7-22143-00	D- 5		D-10	56W-2512A-10	D-14	3JB-26240-00	E- 4	4H7-46152-00	D- 6	E-11	
4X7-22189-01	D- 5	1W1-23173-L0	D- 9	3LP-2516A-00	D-15	3JB-26241-00	E- 4	4H7-46153-00	D- 6	1AA-83318-00	E-11
2H7-2219X-00	D- 5		D-10	42X-25181-00	D-14	3JB-26273-00	E- 4	4X7-46172-00	D- 7	E-11	
3JK-22210-01	D- 5	11H-23173-00	D- 9	42X-25190-00	D-14	3JB-2628J-00	E- 4	4X7-46180-00	D- 7	1AA-83328-00	E-11
3JK-22220-01	D- 5		D-10	3LP-25304-00	E- 2	1J7-26290-F0	E- 4	1RM-81410-20	E- 9	42X-83328-00	E-11
57A-22243-01	D- 5	278-23181-50	D- 9	3LP-25311-00-35	E- 2	1J7-26290-G0	E- 4	3JK-81450-00	E- 9	2EN-83330-00	E-11
3JK-23102-10	D- 9		D-10	146-25315-00	E- 2	3CF-26311-00	E- 4	3JK-81670-00	E- 9	341-83333-70	E-11
3LP-23102-30	D- 9	1UF-23317-01	D- 8	42H-25321-02	E- 2	3CF-26312-00	E- 4	5A8-81800-10	E-10	41R-83350-71	F- 4
3JK-23103-10	D- 9	3LP-23317-00	D-15	4H7-2533A-02	E- 2	3CF-26331-01	E- 4	3JK-81815-00	F- 4	42X-83359-00	E-11
3LP-23103-30	D- 9	2AE-23340-30	D-10	4H7-25351-00	E- 2	57A-26335-00	E- 4	5A8-81826-10	E-10	E-11	
1RM-23110-00	D- 9	1J7-23415-00	D- 8	3CF-25355-00	E- 2	1E6-26342-00	E- 4	5A8-81830-10	E-10	42X-83363-00	E-11
	D-10	26H-23418-01	D- 8	42H-25364-00	E- 2	5H0-26393-00	E- 4	5A8-81840-10	E-10	E-11	
31A-23111-31	D- 9	4H7-23441-00-38	D- 8	16G-25366-01	E- 2	42X-27111-00-R4	E- 6	11H-81844-00	E-10	1RM-83371-00	F- 4
	D-10	42X-23442-00-38	D- 8	42X-25371-00	E- 3	371-27114-00	E- 6	1J7-81847-60	E-10	1RM-83371-10	F- 4
1W1-23114-L0	D- 9	134-23484-10	C-15	4H7-25377-00	E- 3	3CF-27211-00-93	E- 6	5A8-81847-10	E-10	42X-83507-00	E-12
	D-10	1TE-24110-00-W1	D-11	42X-25381-00	E- 3	42X-27212-01	E- 6	25G-81950-01	F- 4	42X-83508-00	E-12
42X-23118-00	D- 9	1TE-24110-00-X3	D-11	3LP-25398-00	D-14	3CF-27231-01	E- 6		F- 4	1RM-83509-00	E-12
	D-10	1RM-24161-10	D-11		E- 2	3CF-27241-00	E- 6	42X-81960-A1	F- 4	42X-83517-00	E-12
1RM-23122-00	D- 8	4PW-24161-00	D-11	3LP-25398-10	D-14	42X-27311-00-93	E- 6	4U8-81980-M0	F- 4	1FG-83519-00	E-12
2YK-23125-00	D- 9	1RM-24162-10	D-11		E- 2	3CF-27410-00-93	E- 6	11K-82110-79	F- 2	1FG-83523-00	E-12
	D-10	4PW-24162-00	D-11	3LP-25398-20	D-14	1NH-27413-00	E- 6	42H-82115-00	F- 2	1FK-83523-00	E-12
3JK-23126-10	D- 9	4H7-24181-00	D-11		E- 3		E- 7	42X-82116-00	F- 2	3CF-8353E-00	E-12
3LP-23126-30	D- 9	42X-24182-00	D-11	16G-25412-00	E- 2	4X7-27414-00	E- 7	1E6-82131-00	F- 2	3LP-8353E-00	E-12
42X-2313A-00	D- 8	42X-24183-00	D-11	3LP-2580T-00	D-15	1RM-27420-00-93	E- 7	3H5-82150-00	F- 2	3CF-8353H-00	E-12
1RM-23132-00	D-10	42X-24186-00	D-11	3LP-2580U-00	D-15	1RM-27430-01	E- 7	2H7-82151-00	F- 2	1FK-83535-00	E-12
1RM-23132-10	D-10	3JK-24240-50	D-11	3LP-2582T-00	D-15	1NH-27433-00	E- 7	36Y-82151-00	E-12	1RM-83540-00	E-12
3JK-23136-10	D- 9	4PW-24240-00	D-11	3LP-2582U-00	D-15		E- 8	42X-82151-20	E-12	584-83541-00	E-12
3LP-23136-30	D- 9	42H-24280-00	D-11	4DN-25827-00	D-15	1HX-27437-00	E- 7	3JK-82305-00	F- 2	3LP-83550-00	E-12
42H-23141-00	D- 9	42H-24311-00	D-12		D-15		E- 8	42X-82310-70	F- 2	42X-83559-00	E-12
	D-10	42H-24315-00	D-12	22R-25850-02	E- 5	1RM-27440-01	E- 8	57A-82314-00	F- 2	1FL-83570-F0	E-12
3EN-23144-00	D- 9	42H-24316-00	D-11	3GM-25852-01	E- 5	3CF-27471-01	E- 7	42X-82317-00	F- 2	55R-83579-00	E-12
	D-10	42H-24317-00	D-11	4KO-25854-00	E- 5	3CF-27472-01	E- 7	42X-82320-70	F- 2	2GV-83912-00	E-15
3EN-23145-00	D- 9	42H-24452-00	D-12	4L0-25862-00	E- 5	42X-28100-10	D-13	1J7-82370-00	F- 2	2W1-83922-00	E-15
	D- 9	3JK-24491-00	D-12	4L0-25867-00	E- 5	42X-28185-00	D- 4	1TA-82380-20	F- 3	437-83936-01	E-15

NUMERICAL INDEX

PART NO.	GRID NO.	PART NO.	GRID NO.	PART NO.	GRID NO.	PART NO.	GRID NO.	PART NO.	GRID NO.	PART NO.	GRID NO.
10M-83941-00	E-15	90109-06577	E-15	90176-10075	E- 7	90201-231A2	D- 7	90387-107A7	E- 7	90467-14015	B- 2
10M-83942-00	E-15	90109-06667	B-10	90176-22050	D- 8	90201-255A6	C-10	90387-124F4	C-13	90467-14057	B-11
1AT-83972-00	E-15	90109-06799	E-15	90179-08148	E- 4	90201-30297	C-12	90387-15550	D-14	90468-05113	B- 9
3LP-83972-00	E-15	90109-08368	E- 3	90179-08210	C- 2	90202-05187	C-14	90387-170E5	C- 6		B- 9
1A0-83980-30	F- 2	90109-08406	E- 3	90179-08507	C- 2		D- 3	90387-172A5	D- 7	90468-12006	D- 8
42X-84124-60	E-13	90109-08592	B- 8	90179-09379	B- 5		F- 4	90387-172E5	C- 6	90480-01401	D- 4
42X-84315-01	E-13	90109-08718	D-15		B- 5	90202-05208	B- 2	90387-17543	D- 5		D- 4
42X-84318-00	E-13	90109-10060	E- 7	90179-12248	C-14	90202-26142	D- 8	90387-251E1	C-10	90480-01502	E-14
2AE-84320-60	E-13	90109-10163	E- 6	90179-12325	B- 2	90208-04029	C-15	90401-10102	B- 9	90480-10408	D-11
42X-84330-01	E-13	90110-06077	D-13	90179-12326	B- 2	90209-06205	B- 8	90401-10159	E- 5	90480-12053	D- 4
1A0-84332-60	E-13	90110-06091	D-14	90179-14317	C-10	90209-10131	E-15		E- 5	90480-13163	D-11
198-84334-60	E-13	90110-06093	C- 5	90179-16448	B- 5	90209-22191	C- 9		E- 5	90480-14074	B-13
42X-84338-00	E-13	90116-08360	D- 6	90179-25033	D- 8	90209-27192	C- 9	90401-10160	E- 5	90480-14229	E-14
42X-84345-00	E-13	90116-10249	D- 6	90179-44328	C-10		C- 9	90401-16065	B- 3	90480-16233	D- 4
34L-84346-00	E-13	90116-10344	B- 2	90179-88336	C-10	90214-20022	C- 7	90401-16067	B- 9	90480-16501	E-14
42X-84366-00	E-13	90116-10361	D- 6	90185-14070	D- 6	90215-20182	C- 7	90413-07023	B-11	90480-20302	C- 3
2F9-84375-00	E-13	90116-12469	B- 2	90201-05031	E-12	90215-20231	C- 8	90430-06014	C- 3	90480-20384	D- 4
5Y3-84395-00	E-13	90119-06097	E-14	90201-06057	D-13	90215-22238	D- 5	90430-10148	F- 2	90480-23444	B- 3
2F9-84397-01	E-13	90123-08046	E- 4	90201-06059	D-11	90240-06057	E- 6	90430-15169	B- 9	90480-24186	D-13
2EM-84700-E0	E-14	90149-06011	F- 4	90201-06067	D- 4	90240-06103	E- 6	90430-17168	B- 3	90501-100F8	B-12
1RM-84704-00	E-14	90149-06153	E-15	90201-06073	E-13	90249-12008	E- 6		B- 9	90501-101J5	D-12
31L-84714-00	E-14	90149-06154	D- 2	90201-063A5	F- 3	90269-04003	C-15	90445-081A9	F- 2	90501-102A2	D-12
2AE-84721-00	E-14	90149-08166	C- 6	90201-06643	E- 9	90280-16053	B- 5	90460-12256	B-12	90501-10245	E- 6
42X-84723-01	E-14	90149-08225	D- 2	90201-100A1	D- 8	90282-07042	C- 7	90460-16192	D-11	90501-10312	E-15
2YL-84751-00	E-14	90151-06013	C- 6		E- 7	90338-06121	B- 8	90460-65195	B-12	90501-12743	E- 7
2EN-85130-00	F- 4	90152-05021	F- 3	90201-10118	E- 5	90338-06162	D- 3		B-12		E- 8
3JK-85720-00	F- 3	90157-04001	E-13		E- 5		D-14	90462-08076	C- 4	90501-15636	C- 6
42H-85752-01	F- 4	90157-05084	E-13		E- 5	90338-07043	C-14	90462-08138	C-14	90501-16491	D- 7
42X-85753-00	F- 4	90159-06058	C-14		E- 5	90338-08163	D- 5	90462-10085	C- 5	90501-21133	B- 8
5A8-86110-50	F- 4	90159-06071	D- 4	90201-102G9	B- 2		D- 8	90462-10098	B-10	90501-70762	C-10
90101-06478	E- 6	90159-06110	D- 4	90201-105H3	C-14		D- 8	90462-10143	C- 5	90506-08227	C-13
90101-06576	C- 2	90159-06128	D- 2	90201-105R9	D- 5	90338-09012	E- 7	90462-12142	C- 5	90506-10069	C- 7
	C- 2	90170-06010	E-15	90201-10752	E- 6	90338-20113	D- 5	90465-08256	D-12	90506-20192	E- 6
	E- 2	90170-06184	E- 6	90201-10774	B- 8	90340-14118	D- 7	90465-08309	C- 4	90506-35149	E- 6
90101-06764	B- 8		F- 3	90201-12166	C-13	90340-14130	D- 7	90465-10168	C- 3	90507-20002	E- 2
90101-10303	C-14	90170-06228	C-13	90201-124E4	C-13	90380-06030	C- 5	90465-10264	F- 4	90507-29009	E- 6
90105-06069	B- 8	90170-08173	B- 7	90201-125A3	B- 2	90380-25125	B- 8	90467-07093	B-11	90508-18696	E- 7
90105-06154	B- 9	90170-10219	E- 2		C-14	90387-060A7	D- 4	90467-08092	B-11		E- 7
	C-14	90170-20274	C- 7	90201-12588	C-13	90387-062L2	D-11		B-11	90508-26494	C- 6
90105-10050	E- 7	90170-20327	C- 8		C-13	90387-06249	E-12	90467-10039	B-11	90508-29531	C-13
	D- 2	90171-14044	E- 3	90201-14218	E- 2	90387-064E8	C- 3		B-11	90508-32535	C-13
90105-10217	C- 3	90175-06019	E- 6	90201-146R0	E- 3	90387-065L5	E-14	90467-10091	B-11	90560-06201	E- 6
90105-10275	C-14	90176-06041	D-13	90201-14632	D- 6	90387-07598	B-12	90467-10135	D-11	90560-06258	D-11
90105-10297	C-14	90176-10073	D- 5	90201-14633	C-10	90387-0801M	C- 6		D-12	90560-15116	D-14
90105-10298	C-14	90176-10075	B- 2	90201-154E9	C- 7	90387-087A5	B- 4		D-12	90560-17249	E- 2
90105-10300	D-15		C-14	90201-165H4	B- 5	90387-087K5	E- 7	90467-11044	D-11	91311-08030	D-10
90105-10638	D- 5		C-14	90201-20276	C- 9		E- 7		D-12	91314-06016	B- 2
90106-10052	E- 6		D- 7	90201-225A4	D-13	90387-100E2	C-14		D-12		B- 3

NUMERICAL INDEX

PART NO.	GRID NO.	PART NO.	GRID NO.	PART NO.	GRID NO.	PART NO.	GRID NO.	PART NO.	GRID NO.	PART NO.	GRID NO.
91314-06016	C- 4	91490-16020	E- 8	92907-06600	F- 4	93210-71360	C-10	94110-1904N	D-14	95811-10025	D- 7
	C- 4	91490-20020	E- 3	92907-08100	D- 2	93210-92448	B- 2	94110-1904P	D-14	95817-06016	D- 2
91314-06020	B-10		E- 6		F- 4	93211-01467	B- 4	94114-1504R	E- 2	95817-06025	E-10
	C- 4	91701-06038	E- 7	92907-08200	C- 7	93211-44348	D- 7	94114-1504S	E- 2	95817-08030	C-11
91314-06025	B- 2		E- 8	92907-10100	D- 8	93306-20310	E- 2	94421-19526	D-14	95827-06016	D- 2
	B- 4	91701-08038	E- 7	92990-05100	B-14		E- 2	94430-15525	E- 2	97007-06012	D-12
	B- 8		E- 7	92990-08100	D- 8	93306-20421	C- 9	94580-25066	B- 9	97007-06020	D- 4
	C- 5	91800-06030	B- 2		D-10	93306-20548	C-10	94590-45098	B- 8	97007-06025	E- 5
91314-06030	C- 3	92014-06012	D- 8		E- 3	93306-20550	C- 9	94701-00218	B- 3		E-15
	C- 4	92901-08700	D- 7	92990-08600	D- 8	93306-20901	C-10	94701-00220	B- 3	97007-08016	D-11
91314-06040	B- 4	92907-04600	B-12		E- 3	93306-30202	D-14	95024-06020	E- 5	97007-10016	E- 6
	C- 4	92907-05600	B-12	92990-10100	D- 5	93306-30309	E- 2		E- 5	97017-06016	D-13
	C- 5	92907-06100	C-14		D- 7	93306-30424	C- 9	95024-08020	D- 8		E-13
91314-06050	B-10		D- 2	92995-06100	E- 6	93306-30525	C- 9		E- 8		F- 2
91314-06055	C- 4		D- 2	93101-14102	C- 5	93306-30533	D- 6	95024-08035	D- 5	97017-06020	B-11
91314-06065	C- 4		D- 4	93101-30084	D- 6	93306-30808	B- 5	95024-08045	D- 8	97017-06025	C- 8
91314-08030	D- 8		D- 4	93101-35099	C-10		B- 5		E- 8	97017-08020	B- 3
91314-08050	B- 2		D-12	93101-38098	D- 6	93306-90602	C-12	95027-08045	C-12	97024-06020	C-13
91316-06025	E-13		D-12	93102-10247	C- 6	93306-91201	C- 9		C- 2	97024-06030	E-11
91317-05010	D-11		D-12	93102-12106	C-13	93311-43729	D- 6	95304-06700	C-13	97027-06012	D- 2
91317-06010	B- 3		D-13	93102-22014	D-14	93311-44051	C-10	95304-08700	E- 3		D- 2
	B- 9		E- 5	93102-25017	D- 5	93316-01201	C- 9	95304-10700	E- 6	97027-08012	D- 2
	B- 9		E-12	93102-70167	D- 7	93316-01403	D- 6	95307-05600	E-12	97313-08045	D-10
91317-06012	B-12		E-13	93104-14059	C- 7	93317-22021	C-10	95307-06600	E-14	97707-40014	E-12
	F- 4		E-15	93104-20068	C- 9	93317-41510	D- 6	95307-06700	F- 4	97707-40112	B-12
91317-06016	C- 5		F- 4	93108-23007	D- 7	93332-00001	D- 8	95307-08700	B- 8	97707-40625	E-14
	D-13		F- 4	93210-07135	B-10	93332-00008	D- 8		C- 7	97707-50508	B-12
	E- 9	92907-06200	B-12		C- 3	93332-00010	D- 5		F- 4		B-12
	F- 3		B-13	93210-07438	B- 9	93340-21505	C- 7	95307-10700	D- 8		C-14
91317-06020	D-11		B-13		B- 9	93399-99926	D- 7	95317-06600	D- 3	97707-60520	F- 2
91317-06030	B-12		C- 2		C- 3	93410-22039	D- 7		E-12	98507-03020	E-11
	C- 3		D- 3		C- 5	93410-23056	D- 7	95333-08600	D- 7	98507-04008	E-12
	E- 9		E- 6	93210-10096	B-10	93410-25010	C- 9		D-10	98507-05008	E- 4
91317-06035	B-13		E-12	93210-11368	E-15	93440-14086	B- 2	95601-06100	E- 7	98507-05010	B-14
	D- 3		E-15	93210-14104	C- 6	93440-20088	D- 7	95607-06100	E- 7	98507-05012	B-12
91317-06040	B- 9	92907-06600	B- 8	93210-14359	C-10	93440-30077	C- 9		E-15		B-15
91317-06055	C- 3		B-11	93210-29198	C- 3		C- 9		E-15	98507-05035	E-15
91317-06080	C- 3		B-12	93210-32172	C- 4	93450-24028	B- 5	95617-08640	B- 2	98507-05040	E-15
91317-06090	B-13		C- 2	93210-44545	B-11	93501-04011	E- 8	95617-10620	C- 3	98507-05045	E-15
91317-08020	D- 5		C- 2	93210-48364	C- 7		E- 8		C- 3	98507-06008	E-15
91317-08055	E-13		C-14	93210-48530	E- 2	93604-10011	B- 8	95617-10670	C- 3	98507-06010	C- 4
91317-10060	C- 3		D- 3	93210-52449	C-10	93604-16092	C-12	95704-06500	E-11		D- 4
91317-10070	C- 3		D-12	93210-54452	B-10	93604-20156	C-12	95707-05500	F- 4		D-12
91317-10100	C- 3		E-14	93210-56459	B-10	93605-10090	B- 8	95707-06500	C- 6	98507-06012	F- 2
91401-25020	E- 7		F- 2	93210-57428	E- 2	93606-07082	C- 7	95707-12500	E-11	98507-06016	F- 4
	E- 7		F- 2	93210-59531	E- 2	93608-50158	C-13	95807-06014	B-13	98507-06025	F- 2
91401-30030	E- 3		F- 2	93210-60426	D- 6	93900-00016	E- 2	95807-06016	E-14	98507-06030	C- 4
91490-16020	E- 7		F- 3	93210-62446	B- 3	93900-00030	D-14	95807-06025	B-13	98507-06050	B-12

NUMERICAL INDEX

PART NO.	GRID NO.	PART NO.	GRID NO.	PART NO.	GRID NO.	PART NO.	GRID NO.	PART NO.	GRID NO.
98507-06080	B-12								
98517-06012	C-14								
	D- 3								
	D-12								
	E- 7								
	E- 8								
98517-06030	F- 3								
98580-04008	B-14								
98580-05006	D-10								
98580-05014	B-14								
	B-15								
98701-05035	C-12								
98704-06016	C- 4								
98707-04010	E-12								
98707-04012	E- 5								
98707-06014	C- 4								
98707-06016	C-12								
98904-06010	C- 2								
98980-05016	F- 2								
99006-10600	C-13								
99009-12400	C-13								
99009-13400	C- 6								
99009-20400	C- 9								
99236-00080	D- 2								
99237-00080	D- 4								
	D- 4								
99510-08016	B- 9								
99510-14016	C- 3								
99530-10014	C- 4								
99530-10020	C- 5								

INDEX

(INDIVIDUAL SPEC.)

NUMERICAL INDEX

PART NO.	GRID NO.	PART NO.	GRID NO.	PART NO.	GRID NO.	PART NO.	GRID NO.	PART NO.	GRID NO.	PART NO.	GRID NO.
3CF-W2611-00	G- 6	2AE-82501-01	F-10	95380-05600	G- 3						
1RM-Y2161-R1-JW	F- 6			95707-05500	G- 7						
	F- 9	47G-83350-41	G- 9		G- 7						
	F-12	2AE-83371-01	F-10	97007-06010	G- 4						
	G- 4		F-13		G- 5						
1TA-11102-01	F-15		G- 7	97007-08012	F-10						
1TA-13534-00	F-15	2AE-83371-11	F-10		F-13						
1TA-13535-00	F-15		F-13		G- 7						
2RJ-14118-00	G- 2		G- 7	97707-60114	G- 3						
4G0-14142-37-A0	G- 2	4GK-83371-00	G- 7		G- 3						
41R-14489-00	F-15	4GK-83371-10	G- 7		G- 3						
42H-14714-10	G- 3	2AE-83378-00	F-10		G- 3						
42H-14808-00	G- 3		F-13		G- 3						
1TA-14840-00	G- 3		G- 7		G- 3						
42H-14857-00	G- 3	2AE-83378-10	F-10		G- 3						
42H-14858-00	G- 3		F-13		G- 3						
42H-14871-01	G- 3		G- 7		G- 3						
42H-14872-02	G- 3	3LP-83570-00	F- 7		G- 3						
42H-14873-01	F-15	55R-84321-H0	F- 7		G- 3						
1TA-14881-00	G- 3	11H-85110-01	G- 7		G- 3						
42H-14882-00	G- 3	20G-85110-00	G- 7		G- 3						
42H-14883-00	G- 3	449-85131-02	G- 9		G- 3						
42H-14884-00	G- 3	47G-85150-00	G- 9		G- 3						
42H-14885-00	G- 3	90171-14029	G- 9		G- 3						
3EF-14900-11	G- 2	90183-05003	G- 9		G- 3						
3EF-14901-11	G- 2	90201-04018	G- 9		G- 3						
3EF-14902-11	G- 2	90202-05057	G- 3		G- 3						
3CF-21110-00-33	F- 6	90267-40076	G- 9		G- 3						
	F- 9	90460-15227	G- 3		G- 3						
	G- 4	90462-20188	G- 3		G- 3						
1RM-21610-01-P2	F- 6	90467-08092	F-15		G- 3						
	F- 9	90467-16098	G- 3		G- 3						
	F-12	90467-22080	G- 3		G- 3						
	G- 4	90468-08104	G- 3		G- 3						
2AE-2164A-00	G- 9	90501-101J3	G- 3		G- 3						
2AE-21641-00	G- 9	90501-101J4	G- 3		G- 3						
4GK-21688-00	G- 4	90506-18224	G- 9		G- 3						
4GK-21689-00	G- 4	90506-26225	G- 9		G- 3						
1JK-21735-00	G- 4	92017-06020	G- 4		G- 3						
4E7-25188-00	G- 9	92907-06100	G- 4		G- 3						
42X-25875-00	G- 4		G- 5		G- 3						
42X-25876-00	G- 4	92907-08100	F-10		G- 3						
1FK-26240-00	G- 6		F-13		G- 3						
42X-26241-00	G- 6		G- 7		G- 3						
26H-2628J-00	G- 6	92907-08600	F-10		G- 3						
	G- 6		F-13		G- 3						
3Y3-27315-00	G- 9		G- 7		G- 3						
2AE-82501-01	F- 7	92990-05200	G- 3		G- 3						

*COPYRIGHT: All rights reserved. No part of this publication
may be reproduced without permission.*

YAMAHA

YAMAHA MOTOR CO., LTD.
2500 SHINGA I IWATA SHIZUOKA JAPAN
SERVICE INFORMATION DIV.

Printed in Japan
First edition NOV., 1994