

**YAMAHA**



# **PARTS CATALOGUE**

**XV250'95 (3LS7/ 3LS8/ 3LU4)**

**XV250S'95 (3LS9/ 3LSA/ 3LU5)**

**EUROPE**

---

**153LS-300E2**

**YAMAHA**  
**GENUINE**  
Parts & Accessories

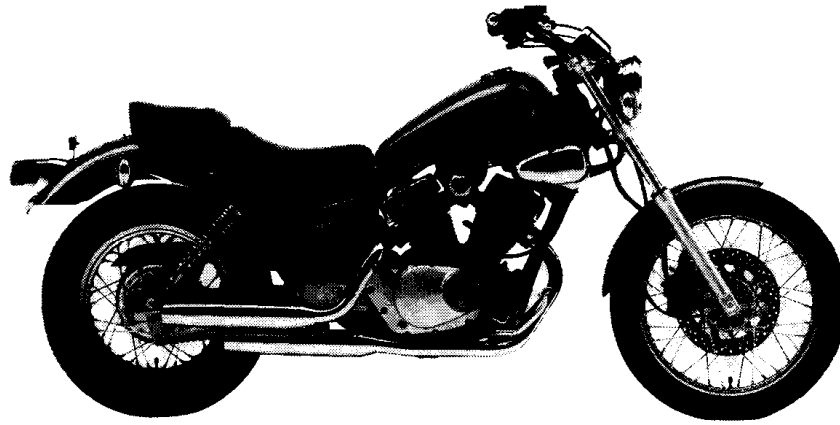

XV250 MODEL

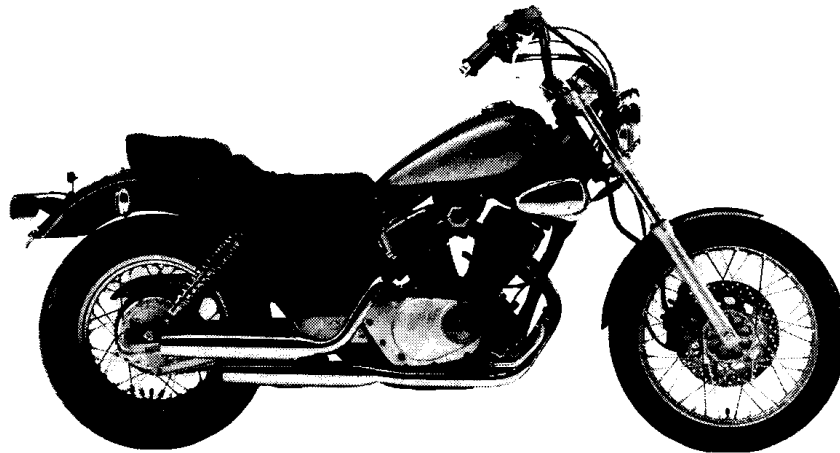

XV250S MODEL

**A3**

## FOREWORD

This Parts Catalogue is related to the parts for the model(s) in the below frame. When you are ordering replacement parts, please refer to this Parts Catalogue and quote both part numbers and part names correctly.

XV250'95(3LS7, 3LS8, 3LU4) , XV250S'95(3LS9, 3LSA, 3LU5)

1. Modifications or additions which have been made after issue of the Parts Catalogue will be announced in the Yamaha Parts News.  
It is advisable that you make necessary corrections to the Parts Catalogue according to the Yamaha Parts News.

2. Abbreviations

The following abbreviations are used in this Parts Catalogue.

- "UR" Use specified parts number.
- "UN" Use as many as needed.
- "AP" Alternate Parts
- "LM" Local Made (Parts need to be ordered locally)
- "F#" Frame No. (Applicable machine No.)

3. Parts, which are to be supplied in an assembly, are listed with a dot (.) in front of the part name as shown below.

EXAMPLE

- CARBURETOR ASSY
- . JET, PILOT
- . NOZZLE, MAIN

4. Number of component for assembly

The numeral appearing to the right of each component part indicates the quantity of parts for each assembly unit.

EXAMPLE

PART NO.	DESCRIPTION	Q'TY	REMARKS
2F5-83310-60	FRONT FLASHER LIGHT ASSY	2	
115-83311-60	. BULB (6V-18W)	1	

5. Applicable colors of graphics are represented in the "REMARKS" as shown below.

PART NO.	DESCRIPTION	Q'TY	REMARKS
2N4-24110-00-X5	FUEL TANK COMP.	1	MAXIM RED
3J1-24240-10	. GRAPHIC, FUEL TANK	1	for MXR

6. Applicable Serial No. and Color Code

3LS7	① Frame Serial No. 3LS-042101 ~
	② Engine Serial No. 3LS-042101 ~
3LS8	① Frame Serial No. 3LS-055101 ~
	② Engine Serial No. 3LS-055101 ~
3LU4	① Frame Serial No. 3LU-004101 ~
	② Engine Serial No. 3LU-004101 ~
3LS9	① Frame Serial No. 3LS-056101 ~
	② Engine Serial No. 3LS-056101 ~
3LSA	① Frame Serial No. 3LS-061101 ~
	② Engine Serial No. 3LS-061101 ~
3LU5	① Frame Serial No. 3LU-006101 ~
	② Engine Serial No. 3LU-006101 ~

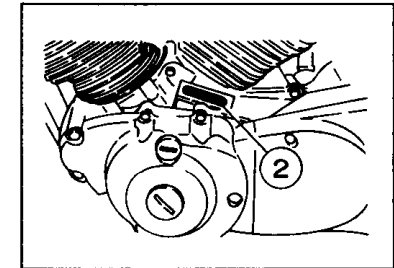
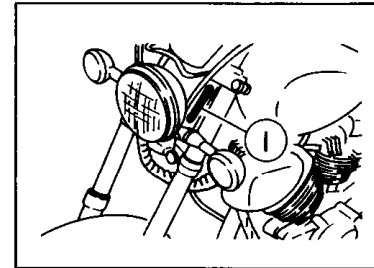

Color Code	Color Name	Abbreviation	
0103	DARK REDDISH GRAY METALLIC 1	DRGM1	(3LS7, 3LS8, 3LU4)
006G	NEW YAMAHA BLACK	NYB	(3LS7, 3LS8, 3LU4)
00MV	RED-E SPARKLE	RES	(3LS9, 3LSA, 3LU5)

7. Note that the illustrations are for reference in finding parts numbers, not to be used for assembling. When assembling, please use the applicable service manual.

8. The asterisk (\*) before a reference number indicates modification items after the first edition.

# CONTENTS

## GENERAL SPEC.

### ENGINE

Cylinder Head .....	B2
Cylinder .....	B3
Crankshaft. Piston .....	B4
Valve .....	B5
Camshaft. Chain .....	B6
Oil Pump .....	B7
Oil Cleaner .....	B8
Intake .....	B9
Carburetor .....	B10~B11
Exhaust .....	B12~B13
Crankcase .....	B14
Crankcase Cover 1 .....	B15
Starter Clutch .....	C2
Clutch .....	C3~C4
Transmission .....	C5
Shift Cam. Fork .....	C6
Shift Shaft .....	C7

### CHASSIS

Frame .....	C8
Fender .....	C9
Side Cover .....	C10
Rear Arm .....	C11
Steering .....	C12~C13
Front Fork .....	C14~C15
Fuel Tank .....	D2~D3
Seat .....	D4
Front Wheel .....	D5
Front Brake Caliper .....	D6

Rear Wheel .....	D7~D8
Steering Handle. Cable .....	D9
Steering Handle. Cable (XV250S) .....	D10
Front Master Cylinder .....	D11
Front Master Cylinder (XV250S) .....	D12
Stand. Footrest .....	D13~D14
Generator .....	D15
Starting Motor .....	E2
Flasher Light .....	E3
Meter .....	E4
Headlight .....	E5
Taillight .....	E6
Handle Switch. Lever .....	E7
Handle Switch. Lever (XV250S) .....	E8
Electrical 1 .....	E9~E10
Electrical 2 .....	E11

### INDEX (GENERAL SPEC.)

Numerical Index .....	L2~L5
-----------------------	-------

## INDIVIDUAL SPEC.

### FOR SWITZERLAND

Alternate (Fender) .....	E13
Alternate (Seat) .....	E14

### FOR SWEDEN PORTUGAL GREECE

Alternate (Front Fork) .....	F2
Alternate (Fender) .....	F3
Alternate (Seat) .....	F4

### FOR SPAIN

Alternate (Front Fork) .....	F6
------------------------------	----

### FOR DENMARK HOLLAND BELGIUM FINLAND

Alternate (Fender) .....	F8
Alternate (Front Fork) .....	F9
Alternate (Seat) .....	F10

### INDEX (INDIVIDUAL SPEC.)

Numerical Index .....	M2
-----------------------	----

**GENERAL SPEC.**

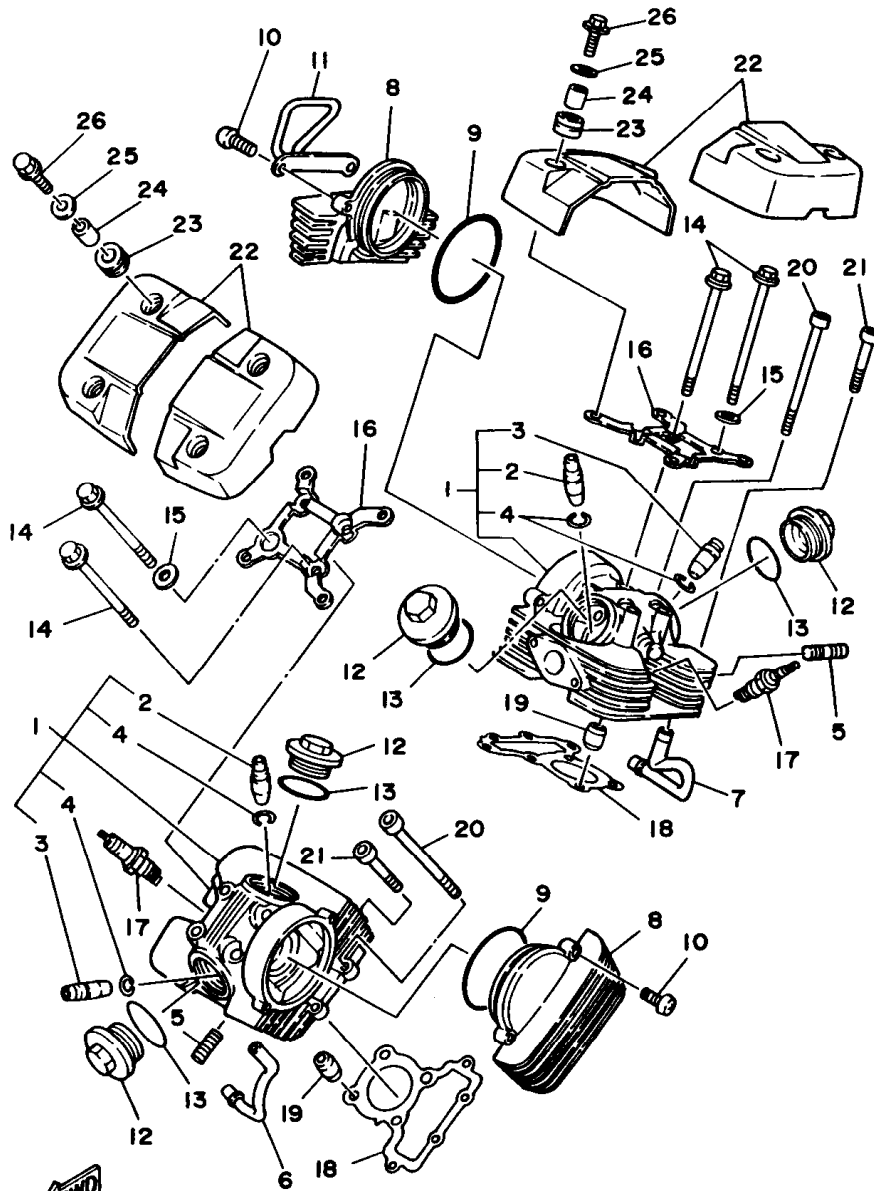

3LS1300-9010

FIG. 1 CYLINDER HEAD

REF. NO.	PART NO.	DESCRIPTION	Q'TY	REMARKS
1	2UJ-11102-00	CYLINDER HEAD ASSY	2	UR
	3BG-11102-00	CYLINDER HEAD ASSY	2	UR FOR SWITZERLAND
2	2UJ-11133-10	.GUIDE, intake valve	1	
3	22F-11134-10	.GUIDE, exhaust valve	1	
4	93440-10109	.CIRCLIP	2	
5	90116-06228	BOLT, stud	4	
6	3BG-14871-00	PIPE 1	1	FOR SWITZERLAND
7	3BG-14872-00	PIPE 2	1	FOR SWITZERLAND
8	2UJ-11185-00	COVER, cylinder head side 1	2	
9	93210-78544	O-RING	2	
10	98507-06025	SCREW, pan head	4	
11	2UJ-11152-00	BRACKET, cylinder head cover	1	
12	22F-11186-00	COVER, cylinder head side 2	4	
13	93210-44704	O-RING	4	
14	90105-08324	BOLT, washer based	8	
15	90201-080L7	WASHER, plate	2	
16	2UJ-11142-00	BRACKET, cylinder head cover 2	2	
17	94701-00282	PLUG SPARK (NGK CR6HS)	2	UR
	94701-00283	PLUG, spark (ND U20FSR-U)	2	UR
18	2UJ-11181-01	GASKET, cylinder head 1	2	
19	99510-10114	PIN, dowel	4	
20	91317-06110	BOLT	4	
21	91317-06040	BOLT	4	
22	2UJ-11186-00	COVER, cylinder head side 2	4	
23	90480-13018	GROMMET	8	
24	90387-066M3	COLLAR	8	
25	90201-06697	WASHER, plate	8	
26	95024-06020	BOLT	8	

**B2**

FIG. 2 CYLINDER

REF. NO.	PART NO.	DESCRIPTION	Q'TY	REMARKS
1	2UJ-11310-01	CYLINDER	1	UR
	3BG-11310-00	CYLINDER	1	UR FOR SWITZERLAND
2	2UJ-11320-01	CYLINDER 2	1	UR
	3BG-11320-00	CYLINDER 2	1	UR FOR SWITZERLAND
3	15A-11162-00	ABSORBER 2	12	FOR SWITZERLAND
4	3DM-11351-00	GASKET, cylinder	2	
5	93210-53679	O-RING	2	

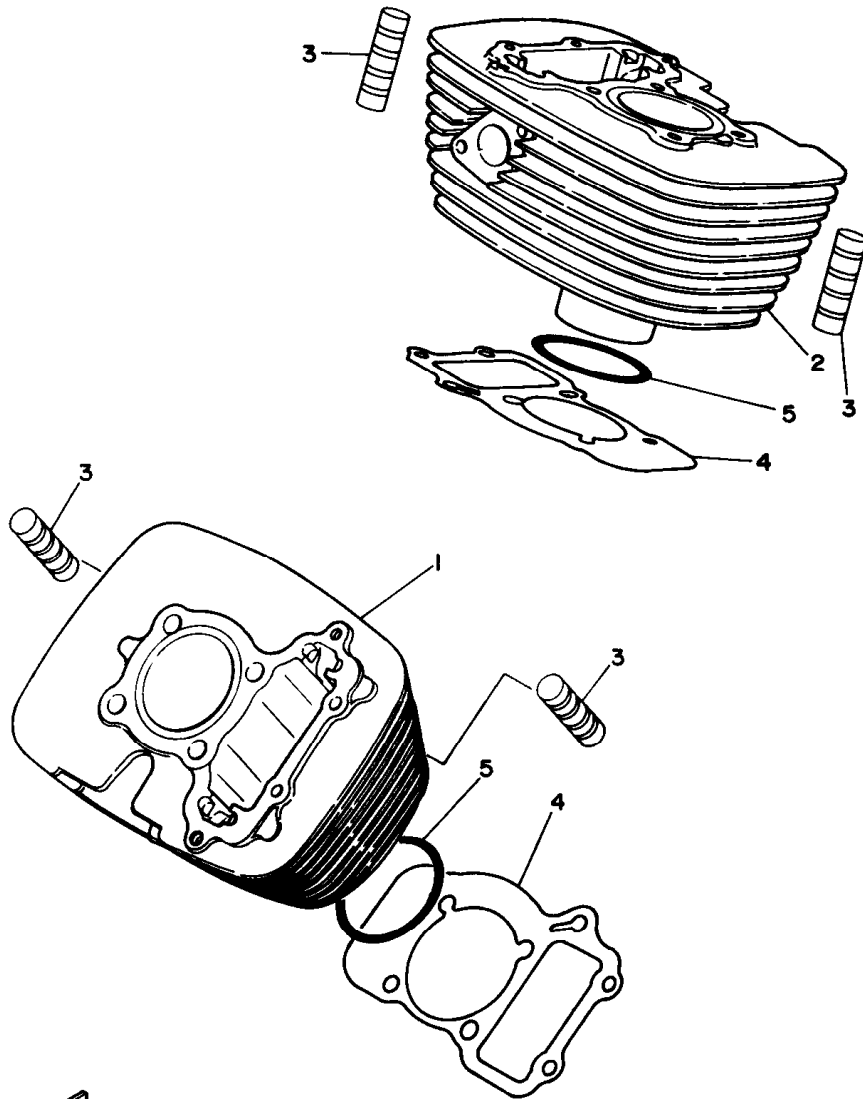

3LS2300-2020

**B3**

FIG. 3 CRANKSHAFT, PISTON

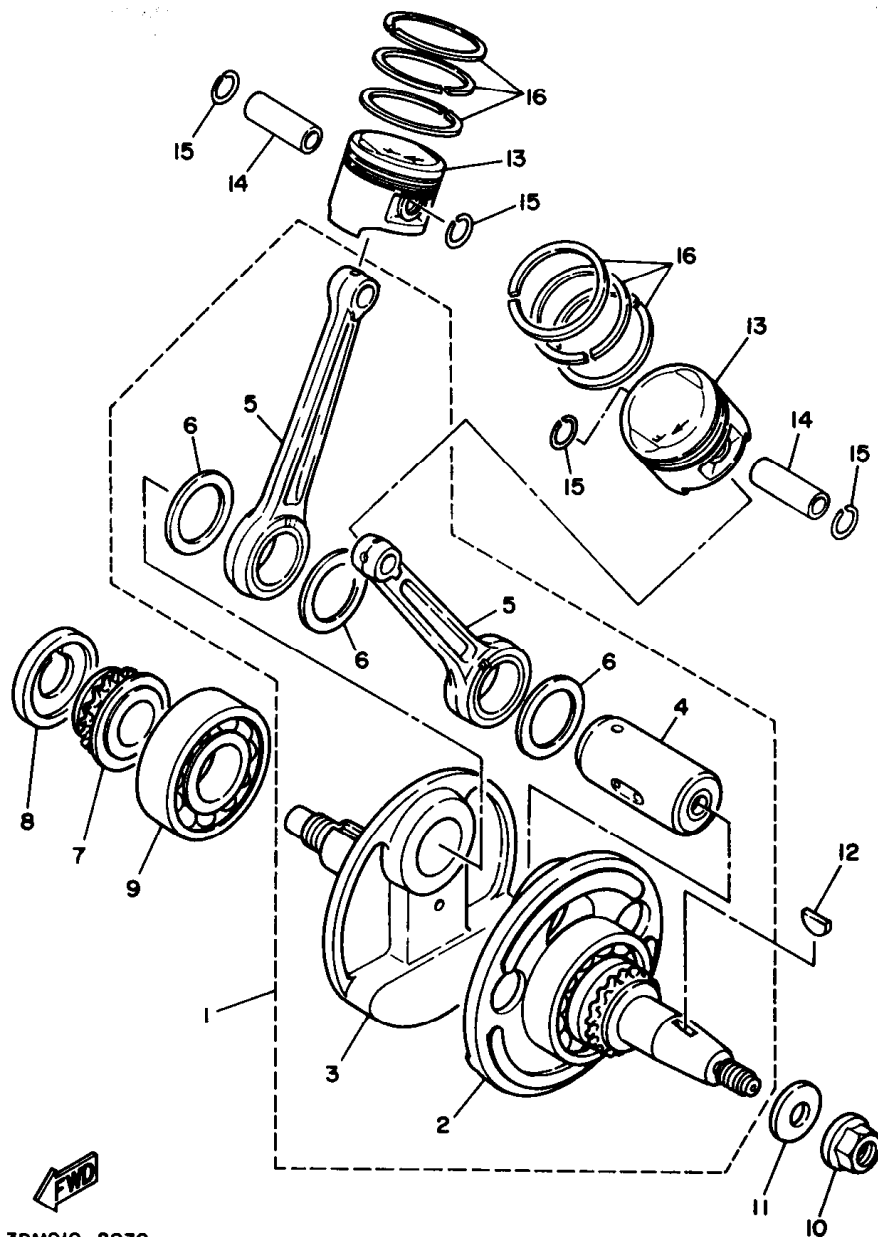

REF. NO.	PART NO.	DESCRIPTION	Q'TY	REMARKS
1	2UJ-11400-00	CRANKSHAFT ASSY	1	
2	2UJ-W1141-00	.CRANK 1	1	
3	2UJ-11422-00	.CRANK 2	1	
4	2UJ-11681-00	.PIN, crank 1	1	
5	2UJ-11651-00	.ROD, connecting	2	
6	90209-31300	.WASHER	3	
7	2UJ-1154A-00	SPROCKET, cam chain 2	1	
8	2UJ-11478-00	COLLAR	1	
9	93306-30615	BEARING (B6306)	1	
10	90179-12248	NUT	1	
11	90201-12191	WASHER, plate	1	
12	90280-16053	KEY, woodruff	1	
13	2UJ-11631-00-A0	PISTON (STD)	2	
	2UJ-11636-00	PISTON (0.50MM O/S)	2	AP
	2UJ-11638-00	PISTON (1.00MM O/S)	2	AP
14	22K-11633-01	PIN, piston	2	
15	93450-14088	CIRCLIP	4	
16	50M-11610-00	PISTON RING SET (STD)	2	
	50M-11610-20	PISTON RING SET (0.50MM O/S)	2	AP
	50M-11610-40	PISTON RING SET (1.00MM O/S)	2	AP

3DM010-8030

**B4**



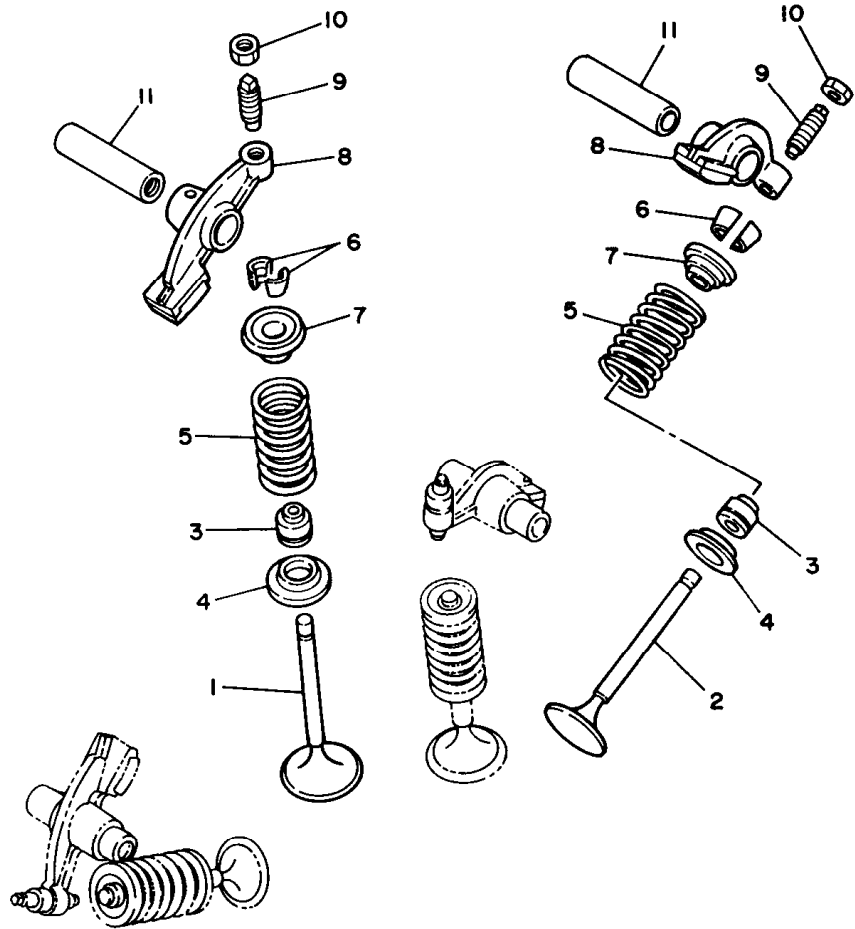

FIG. 4 VALVE

REF. NO.	PART NO.	DESCRIPTION	Q'TY	REMARKS
1	50M-12111-00	VALVE, intake	2	
2	50M-12121-01	VALVE, exhaust	2	
3	22F-12119-01	SEAL, valve stem	4	
4	22F-12116-00	SEAT, valve spring	4	
5	2UJ-12114-00	SPRING, valve outer	4	
6	22F-12118-01	COTTER, valve	8	
7	22F-12117-02	RETAINER, valve spring	4	
8	50M-12151-00	ARM, valve rocker	4	
9	22F-12159-00	SCREW, valve adjusting	4	
10	90170-05302	NUT	4	
11	22F-12156-00	SHAFT, rocker 2	4	



3DM010-8040

**B5**

FIG. 5 CAMSHAFT. CHAIN

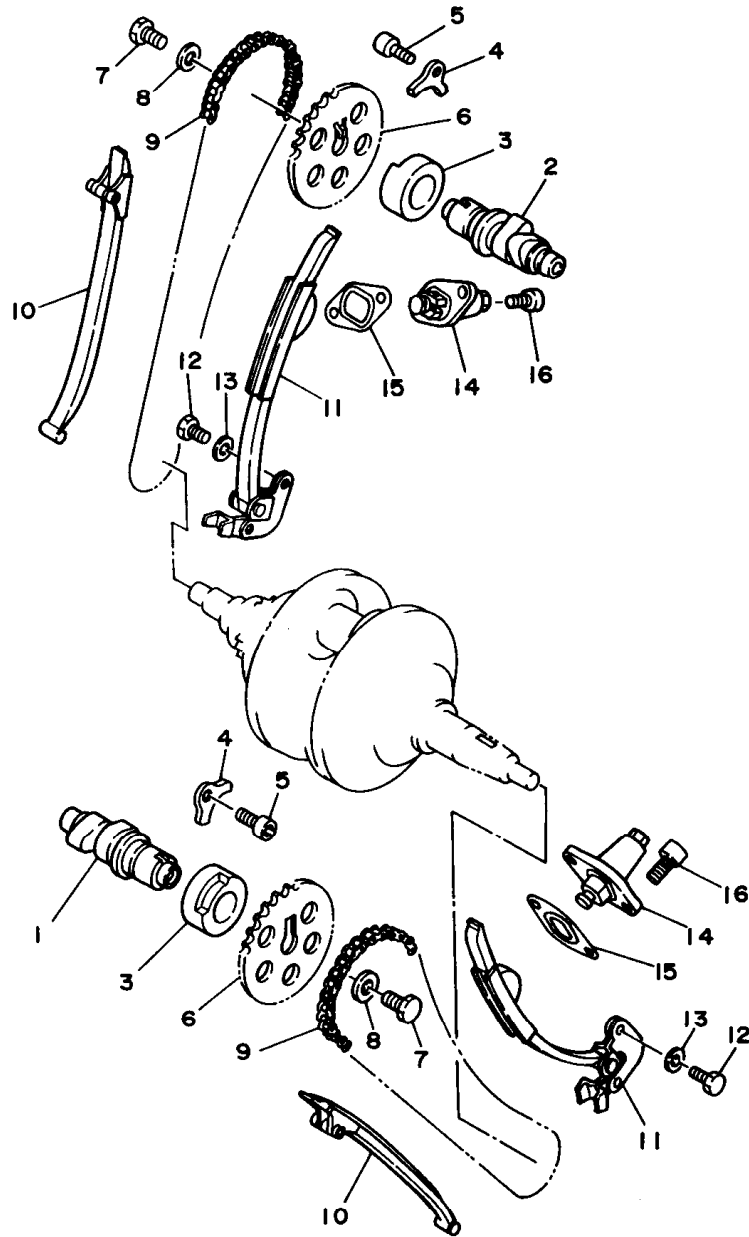

REF. NO.	PART NO.	DESCRIPTION	Q'TY	REMARKS
1	2UJ-12171-00	CAMSHAFT 1	1	
2	2UJ-12181-00	CAMSHAFT 2	1	
3	90381-22070	BUSH, solid	2	
4	2UJ-1111F-00	PLATE	2	
5	91317-06012	BOLT	2	
6	2UJ-12176-00	SPROCKET, cam chain	2	
7	90101-08590	BOLT	2	
8	90201-08326	WASHER, plate	2	
9	94580-25110	CHAIN	2	
10	2UJ-12231-00	GUIDE, stopper 1	2	
11	2UJ-12241-00	GUIDE, stopper 2	2	
12	97027-06012	BOLT	4	
13	92907-06600	WASHER, plate	4	
14	2UJ-12210-01	TENSIONER ASSY, cam chain	2	
15	3DM-12213-00	GASKET, tensioner case	2	
16	91314-06016	BOLT	4	

  
3DM010-8050

**B6**

FIG. 6 OIL PUMP

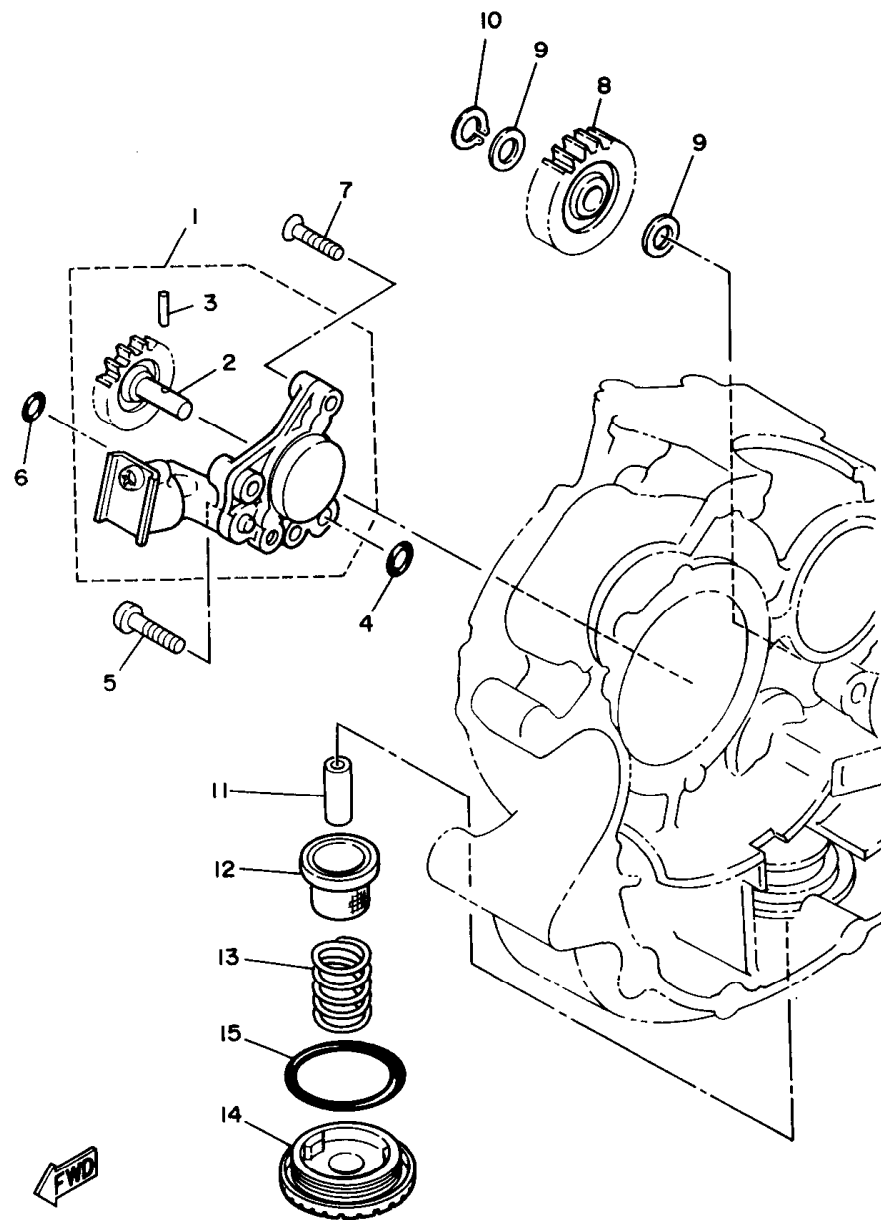

REF. NO.	PART NO.	DESCRIPTION	Q'TY	REMARKS
1	2UJ-13300-00	OIL PUMP ASSY	1	
2	3Y6-13326-01	.GEAR, pump driven 2 (23T)	1	
3	93603-12030	.PIN, dowel	1	
4	93210-10096	O-RING	1	
5	98507-06025	SCREW, pan head	2	
6	93210-06245	O-RING	1	
7	98707-06025	SCREW, flat head	1	
8	2UJ-13341-00	GEAR, oil pump idle	1	
9	90201-10119	WASHER, plate	2	
10	99009-10400	CIRCLIP	1	
11	2XK-13416-00	PIPE, oil 1	1	
12	51Y-13411-00	STRAINER, oil	1	
13	90501-18576	SPRING, compression	1	
14	30X-15351-00	PLUG, drain	1	
15	93210-35389	O-RING	1	

3DM010-8060

**B7**

FIG. 7 OIL CLEANER

REF. NO.	PART NO.	DESCRIPTION	Q'TY	REMARKS
1	4X7-13440-90	ELEMENT ASSY, oil cleaner	1	
2	3DM-13447-00	COVER, oil element	1	
3	93210-64297	O-RING	1	
4	98504-06090	SCREW, pan head	1	
5	98504-06025	SCREW, pan head	2	

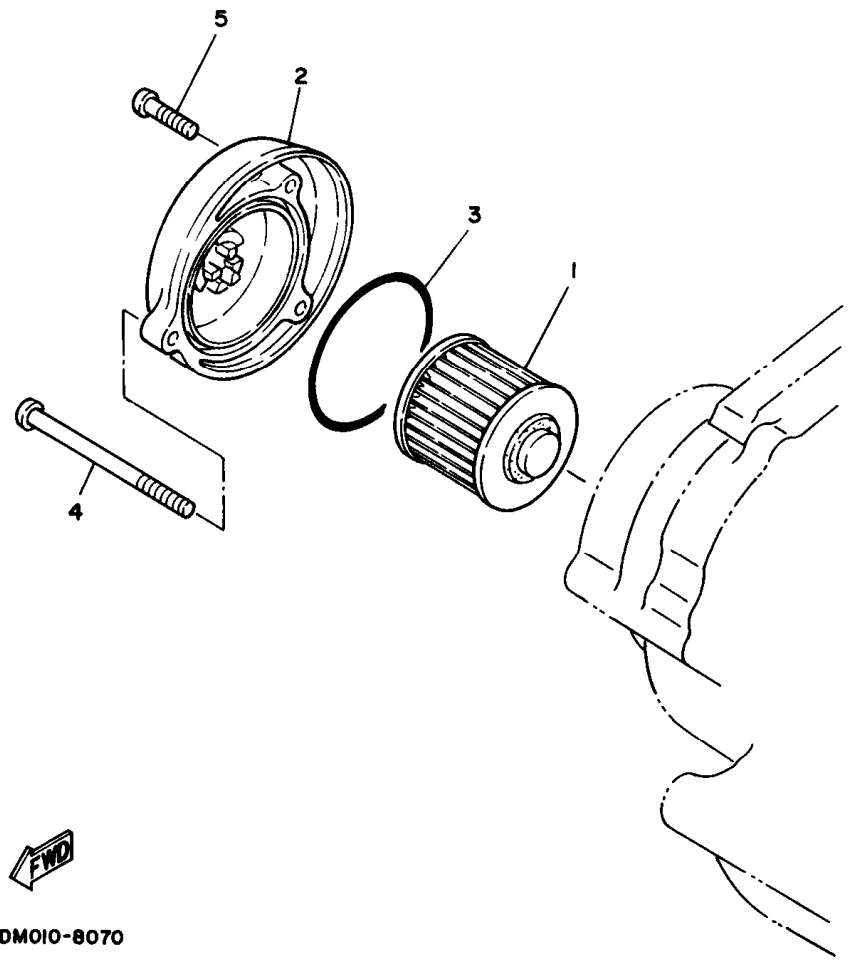

3DM010-8070

**B8**

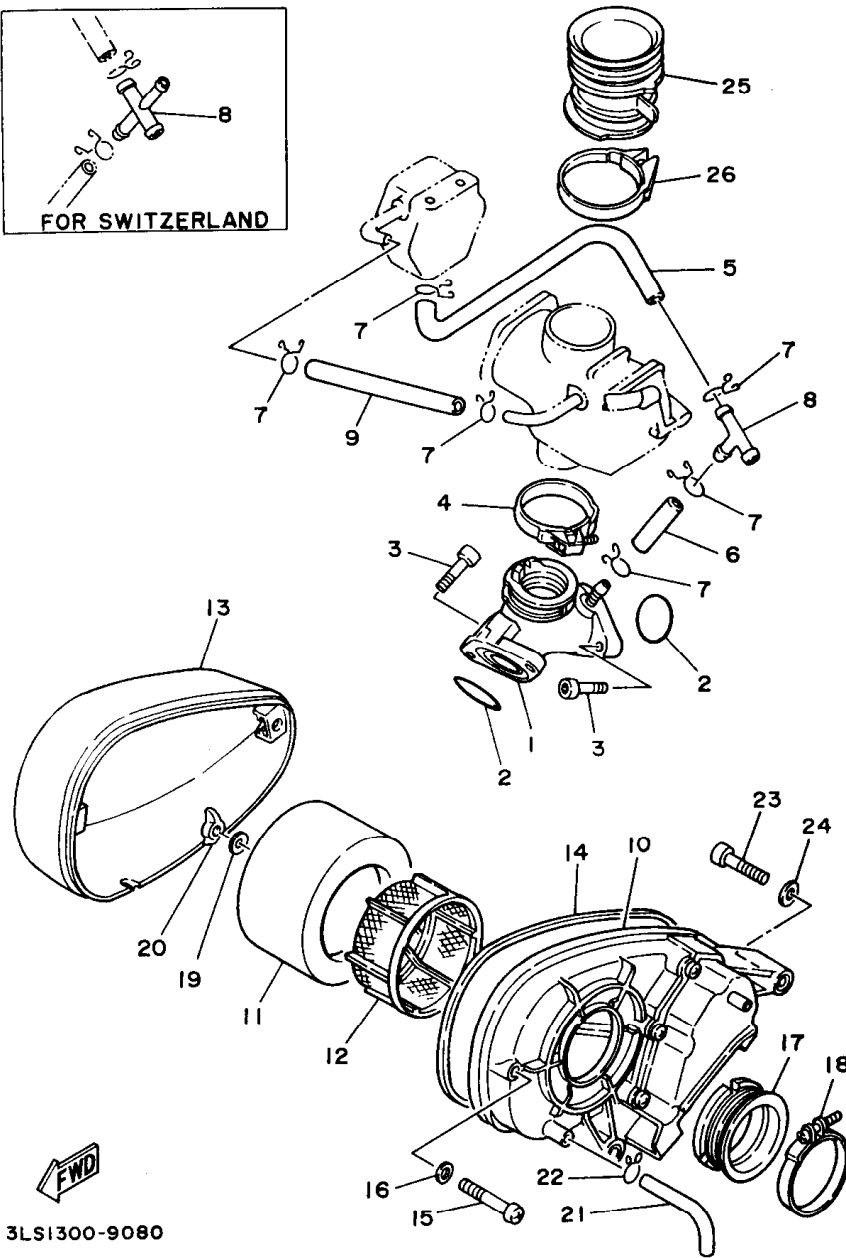
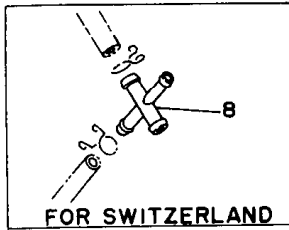

3LS1300-9080

FIG. 8 INTAKE

REF. NO.	PART NO.	DESCRIPTION	Q'TY	REMARKS
1	2UJ-13586-00	JOINT, carburetor 1	1	
2	93210-30611	O-RING	2	
3	91317-06020	BOLT	4	
4	1HX-13575-00	BAND	1	
5	2UJ-13978-00	PIPE, regulator	1	
6	90445-11763	HOSE	1	
7	90467-10008	CLIP	6	
8	90413-07007	WAY 3	1	UR
	3BG-13595-00	JOINT	1	UR FOR SWITZERLAND
9	90445-117F0	HOSE	1	
10	2UJ-14401-00	AIR CLEANER CASE ASSY	1	
11	2UJ-14451-00	ELEMENT, air cleaner	1	
12	2UJ-14458-00	GUIDE	1	
13	2UJ-14422-00	CAP, cleaner case 2	1	
14	2UJ-14452-00	SEAL	1	
15	98507-06040	SCREW, pan head	2	
16	92907-06600	WASHER, plate	2	
17	2UJ-14485-00	PIPE, joint	1	
18	90460-54111	CLAMP, hose	1	
19	90201-05036	WASHER, plate	1	
20	90175-05005	NUT, wing	1	
21	2UJ-14419-00	PIPE	1	
22	90467-11106	CLIP	1	
23	91317-06025	BOLT	2	
24	92907-06600	WASHER, plate	2	
25	2UJ-14469-00	FUNNEL, air	1	
26	90460-54137	CLAMP, hose	1	

**B9**

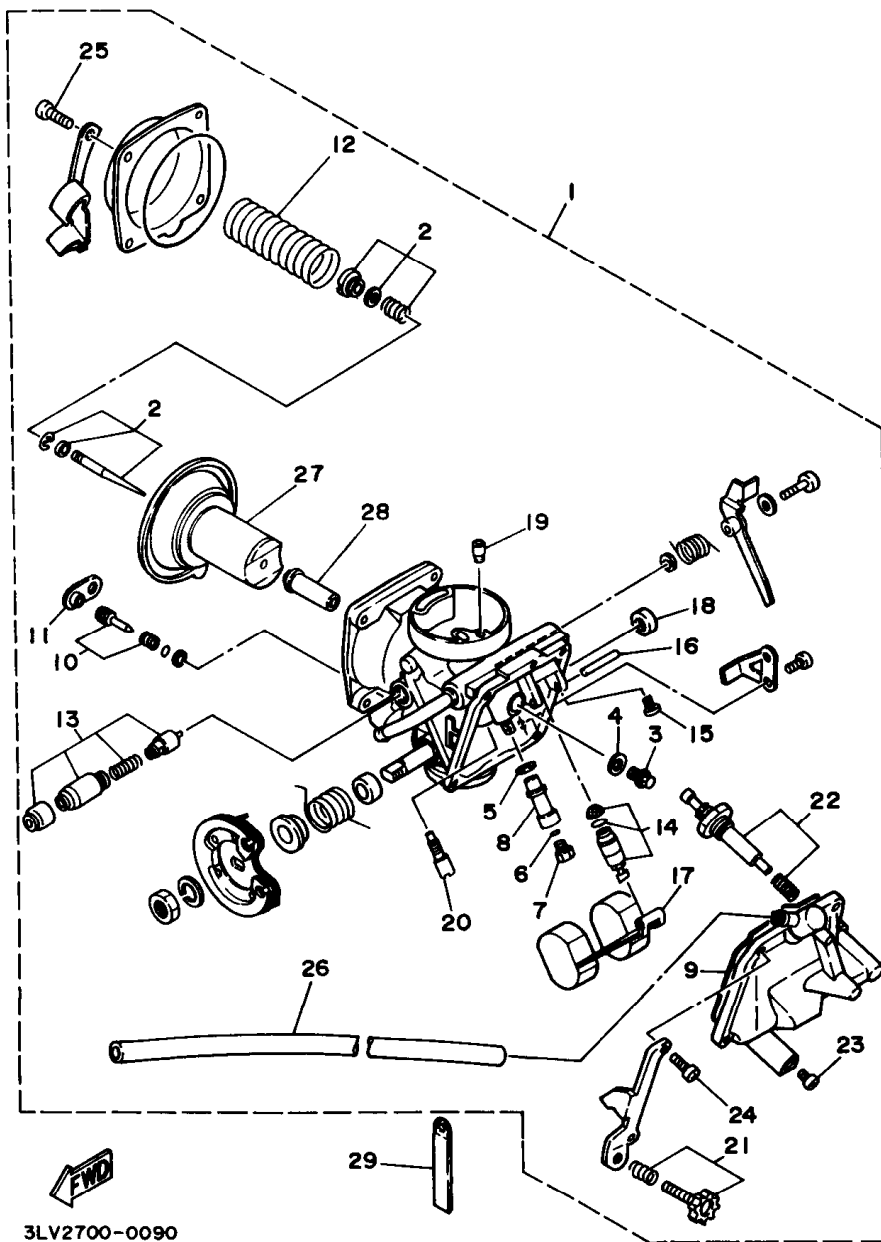

3LV2700-0090

FIG. 9 CARBURETOR

REF. NO.	PART NO.	DESCRIPTION	Q'TY	REMARKS
1	3DM-14900-10	CARBURETOR ASSY	1	UR
	3LU-14900-10	CARBURETOR ASSY	1	UR FOR SWITZERLAND
2	3DM-1490J-00	.NEEDLE SET	1	UR
	3BG-1490J-00	.NEEDLE SET	1	UR FOR SWITZERLAND
3	1HX-14565-00	.SCREW	1	
4	137-14153-00	.WASHER, main jet	1	
5	1AE-14237-00	.GASKET	1	
6	1AE-14227-00	.O-RING	1	
7	620-14231-22-A0	.JET, main (#110)	1	
8	1AE-14261-00	.HOLDER	1	
9	1HX-14147-00	.O-RING	1	
10	12R-14105-00	.PILOT SCREW SET	1	
11	22F-14991-00	.CAP	1	UR
	2RJ-14118-00	.CAP	1	UR FOR SWITZERLAND
12	1HX-14933-00	.SPRING, diaphragm	1	
13	3DM-1410A-10	.STARTER SET	1	
14	3CF-14107-10	.NEEDLE VALVE SET	1	
15	1FN-14565-00	.SCREW	1	
16	353-14186-00	.PIN, float	1	
17	1HX-14985-00	.FLOAT	1	
18	256-14997-00	.SEAL	1	
19	1HX-14231-31	.JET, main (#155)	1	
20	22F-14142-17	.JET, pilot (# 17.5)	1	
21	1HX-14103-00	.THROTTLE SCREW SET	1	
22	3DM-14504-01	.ROD SET	1	
23	12R-14191-00	.PLUG, drain	1	
24	98503-04014	.SCREW, pan head	2	
25	98511-04012	.SCREW, pan head	4	

**B10**

FIG. 9 CARBURETOR

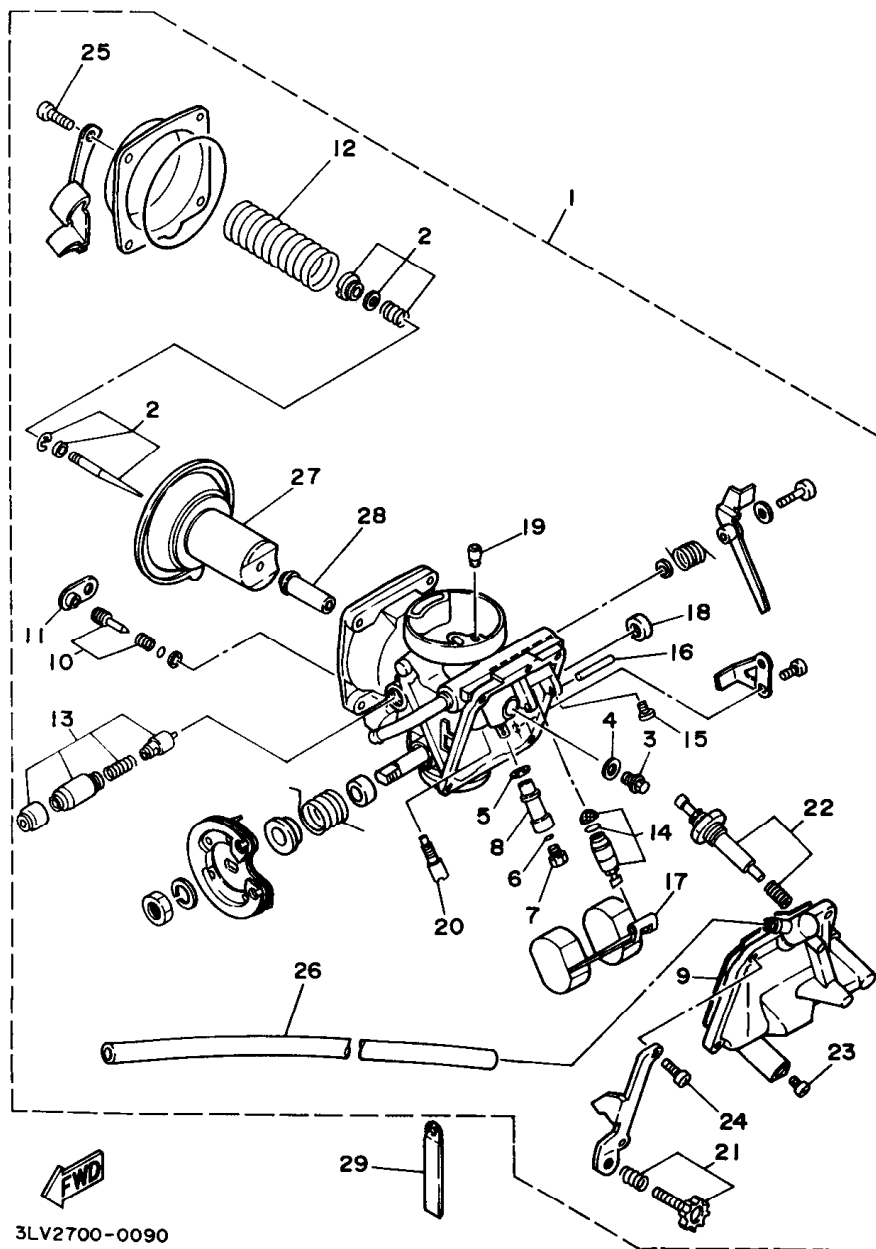

3LV2700-0090

REF. NO.	PART NO.	DESCRIPTION	Q'TY	REMARKS
26	2LH-14197-00	.PIPE	1	
27	3BG-14940-00	.DIAPHRAGM ASSY	1	
28	3DM-14141-30	.MAIN NOZZLE (0-0)	1	
29	90461-06087	CLAMP	1	

**B11**

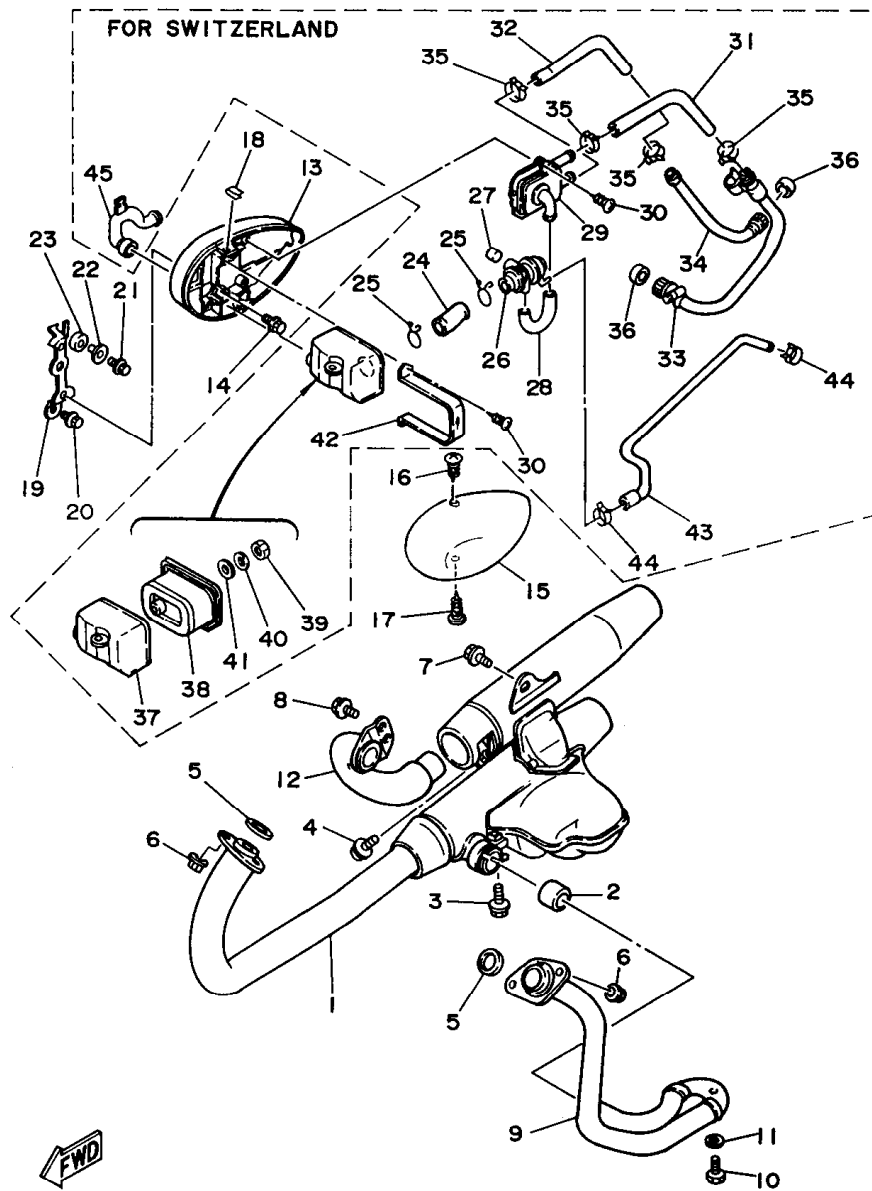

3LS1300-9100

FIG. 10 EXHAUST

REF. NO.	PART NO.	DESCRIPTION	Q'TY	REMARKS
1	3DM-14703-10	MUFFLER COMP 1	1	UR
	3LU-14703-00	MUFFLER COMP 1	1	UR FOR SWITZERLAND
2	3DM-14714-00	GASKET, muffler	1	
3	95817-08035	BOLT, flange	1	
4	95807-06025	BOLT, flange	1	
5	3DM-14613-00	GASKET, exhaust pipe	2	
6	90179-06500	NUT	4	
7	95807-10014	BOLT, flange	1	
8	95807-08012	BOLT, flange	2	
9	2UJ-14621-00	PIPE, exhaust 2	1	
10	90101-06576	BOLT	1	
11	92907-06600	WASHER, plate	1	
12	2UJ-14631-00	PIPE, exhaust 3	1	
13	2GV-14663-00	PLATE, air cleaner	1	
14	95807-06020	BOLT, flange	2	
15	2GV-14603-00	COVER 1	1	
16	97704-40012	SCREW, tapping	1	
17	90163-04003	SCREW, tapping	1	
18	90183-04027	NUT, spring	2	
19	2UJ-14484-00	PLATE, cleaner case fitting	1	
20	95807-06010	BOLT, flange	1	
21	95807-06025	BOLT, flange	1	
22	90387-07391	COLLAR	1	
23	90385-10026	BUSH	1	
24	3BM-14882-00	HOSE, bend 2	1	
25	90467-26111	CLIP	2	
26	3BG-14840-00	AIR CUT VALVE ASSY	1	FOR SWITZERLAND
27	90338-10132	PLUG	1	

**B12**



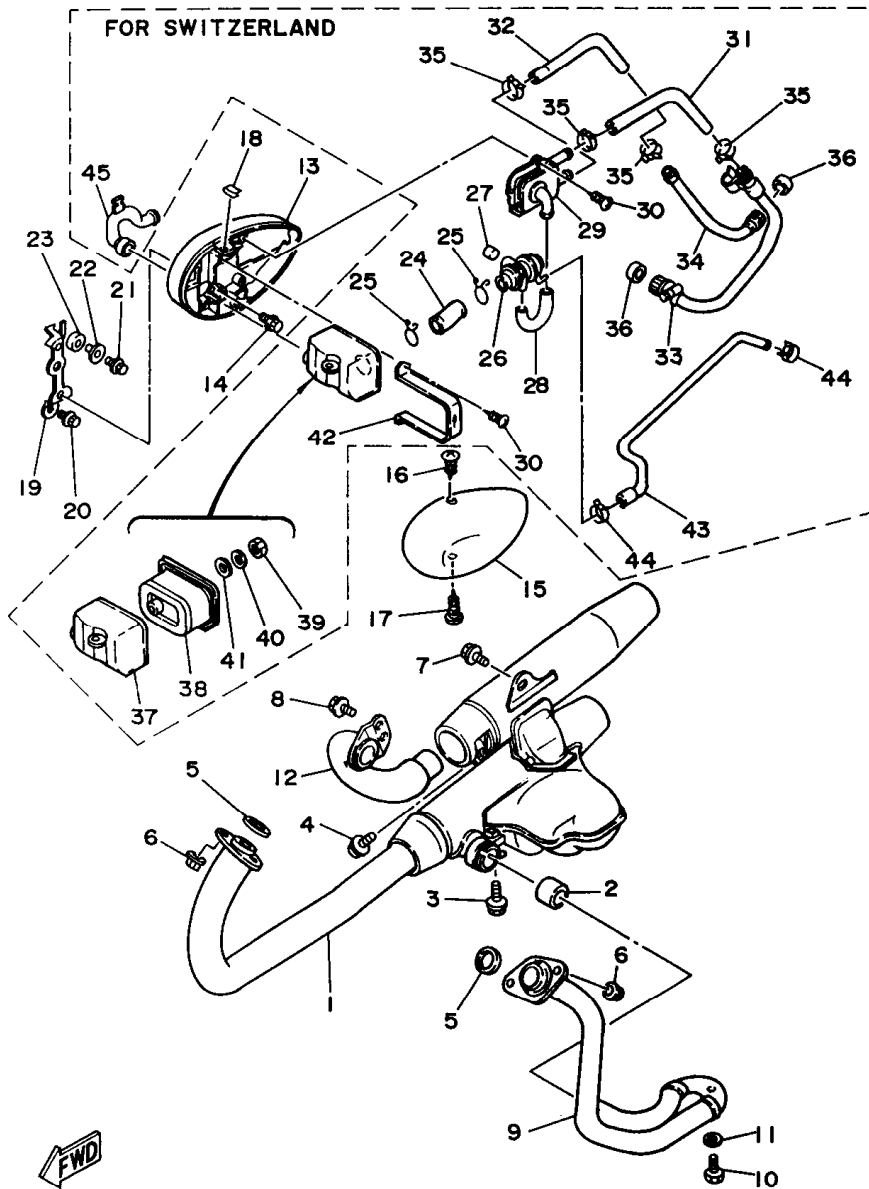

3LS1300-9100

FIG. 10 EXHAUST

REF. NO.	PART NO.	DESCRIPTION	Q'TY	REMARKS
28	3BM-14883-00	HOSE, bend 3	1	} FOR SWITZERLAND
29	42H-14808-00	REED VALVE ASSY	1	
30	97707-60114	SCREW, tapping	5	
31	3BG-14884-00	HOSE, bend 4	1	
32	3BG-14885-00	HOSE, bend 5	1	
33	3BG-14873-00	PIPE 3	1	
34	3BG-14874-00	PIPE 4	1	
35	90468-08104	CLIP	4	
36	3BM-14714-00	GASKET, muffler	2	
37	42H-14857-00	CASE, air cleaner	1	
38	3BG-14858-00	CAP, case	1	
39	95307-05600	NUT	1	
40	92907-05200	WASHER, plain	1	
41	90202-05057	WASHER, plate	1	
42	3BM-14867-00	BRACKET	1	
43	3BG-13542-00	HOSE, vacuum sensing 1	1	
44	90467-08092	CLIP	2	
45	1TA-14881-00	HOSE, bend 1	1	

**B13**

FIG. 11 CRANKCASE

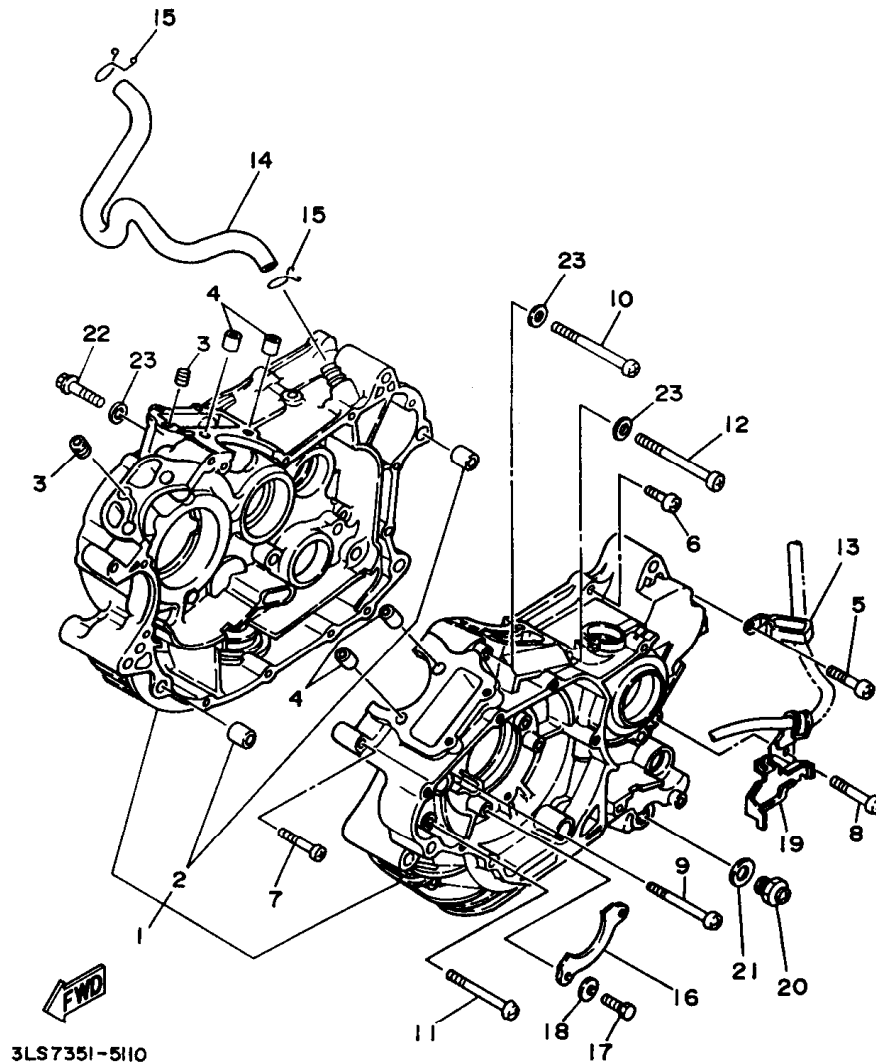

3LS7351-5110

REF. NO.	PART NO.	DESCRIPTION	Q'TY	REMARKS
1	2UJ-15100-02	CRANKCASE ASSY	1	
2	99510-12016	.PIN, dowel	2	
3	2UJ-15138-00	NOZZLE 1	2	
4	99510-10114	PIN, dowel	4	
5	98507-06030	SCREW, pan head	4	
6	98504-06030	SCREW, pan head	1	
7	98504-06040	SCREW, pan head	1	
8	98507-06060	SCREW, pan head	2	
9	98507-06070	SCREW, pan head	1	
10	98504-06070	SCREW, pan head	1	
11	98507-06080	SCREW, pan head	3	
12	98504-06080	SCREW, pan head	1	
13	90465-08277	CLAMP	1	
14	2UJ-11166-00	PIPE, breather 1	1	
15	90467-14015	CLIP	2	
16	2UJ-12279-00	PLATE	1	
17	97027-06012	BOLT	2	
18	92907-06600	WASHER, plate	2	
19	90465-08158	CLAMP	1	
20	3VD-13455-00	PLUG	1	
21	214-11198-01	GASKET	1	
22	90153-06029	SCREW, hexagon	1	
23	90430-06014	GASKET	3	

**B14**

FIG. 12 CRANKCASE COVER 1

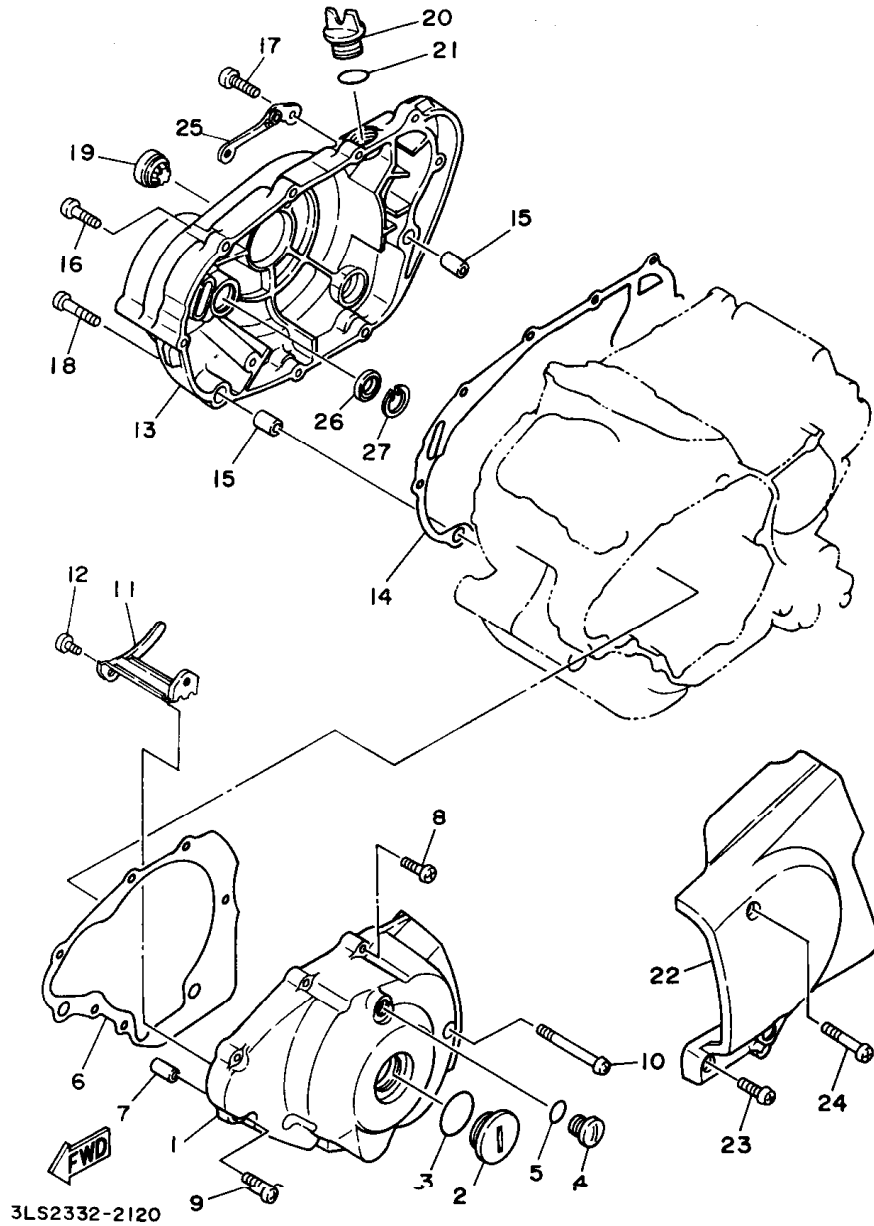

REF. NO.	PART NO.	DESCRIPTION	Q'TY	REMARKS
1	3DM-15411-01	COVER, crankcase 1	1	
2	90340-32088	PLUG, straight screw	1	
3	93210-32172	O-RING	1	
4	90340-14068	PLUG, straight screw	1	
5	93210-14369	O-RING	1	
6	3DM-15451-00	GASKET, crankcase cover 1	1	
7	99510-12016	PIN, dowel	2	
8	98504-06025	SCREW, pan head	5	
9	98504-06035	SCREW, pan head	2	
10	98504-06070	SCREW, pan head	1	
11	90465-06322	CLAMP	1	
12	98507-06010	SCREW, pan head	1	
13	3DM-15421-00	COVER, crankcase 2	1	
14	3DM-15461-00	GASKET, crankcase cover 2	1	
15	99510-12016	PIN, dowel	2	
16	98504-06025	SCREW, pan head	5	
17	90153-06042	SCREW, hexagon	2	
18	98504-06035	SCREW, pan head	2	
19	3Y1-15361-00	GAUGE, level	1	
20	1RG-15363-00	PLUG, oil	1	
21	93210-19123	O-RING	1	
22	3DM-15431-00	COVER, crankcase 3	1	
23	98504-06025	SCREW, pan head	2	
24	98504-06050	SCREW, pan head	1	
25	2UJ-15441-00	HOLDER, clutch cable	1	
26	93101-14089	OIL SEAL	1	
27	93003-23550	SCREW, pan head	1	

3LS2332-2120

**B15**

FIG. 13 STARTER CLUTCH

REF. NO.	PART NO.	DESCRIPTION	Q'TY	REMARKS
1	2UJ-15512-00	GEAR, idler 1	1	
2	5H0-15521-00	SHAFT 1	1	
3	2UJ-15517-00	GEAR, idler 2	1	
4	90201-25291	WASHER, plate	1	
5	51Y-15590-01	STARTER ONE-WAY ASSY	1	
6	91317-08018	BOLT	3	

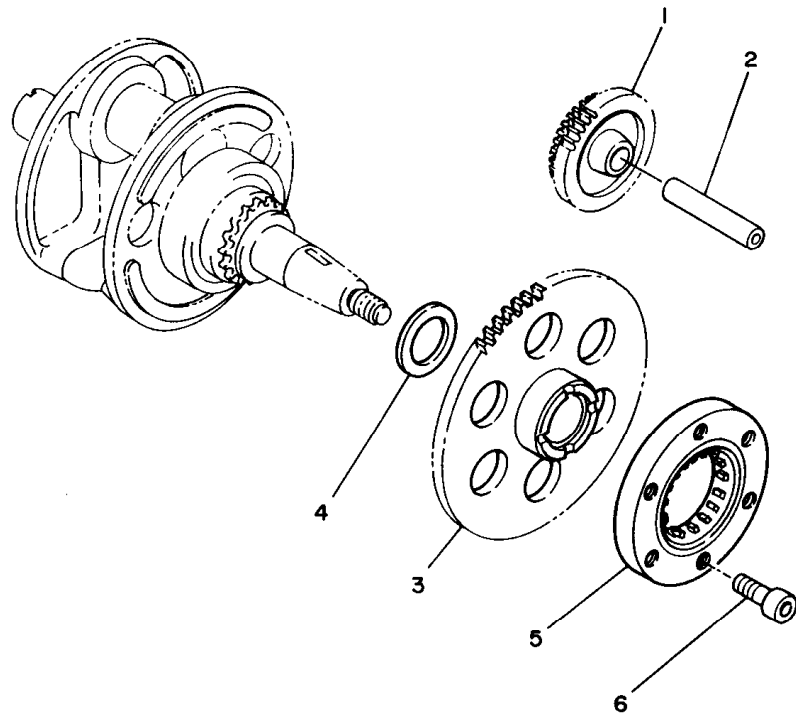

3DM010-8130

**C2**

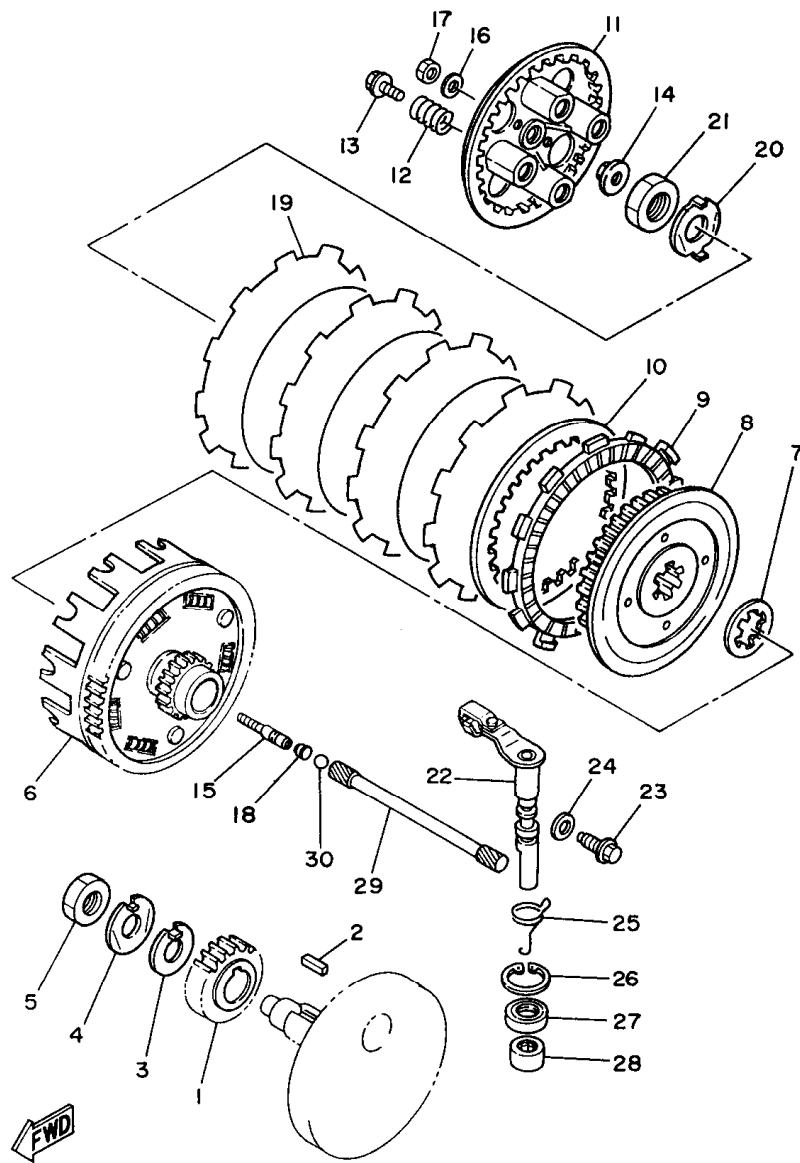

3LS7351-5140

FIG. 14 CLUTCH

REF. NO.	PART NO.	DESCRIPTION	Q'TY	REMARKS
1	3Y6-16111-03	GEAR, primary drive (23T)	1	
2	90282-07023	KEY, straight	1	
3	90215-16156	WASHER, lock	1	
4	90215-16222	WASHER, lock	1	
5	90170-16311	NUT	1	
6	2UJ-16150-00	PRIMARY DRIVEN GEAR COMP.	1	
7	30X-16154-00	PLATE, thrust 1	1	
8	30X-16371-00	BOSS, clutch	1	
9	5Y1-16331-01	PLATE, friction 2	4	
10	3J2-16324-00	PLATE, clutch 1	4	
11	30X-16351-01	PLATE, pressure 1	1	
12	90501-26148	SPRING, compression	4	
13	90159-06016	SCREW, with washer	4	
14	1W1-16358-01	PLATE, push	1	
15	4DN-16356-00	ROD, push 1	1	
16	92907-06200	WASHER, plain	1	
17	95307-06600	NUT	1	
18	3YX-1635A-00	SEAL, push rod	1	
19	31A-16321-00	PLATE, friction	1	
20	90215-16320	WASHER, lock	1	
21	90170-16326	NUT	1	
22	2UJ-16380-00	PUSH LEVER ASSY	1	
23	90149-08067	SCREW	1	
24	90201-08087	WASHER, plate	1	
25	90508-14433	SPRING, torsion	1	
26	93420-28055	CIRCLIP	1	
27	93102-14209	OIL SEAL	1	
28	93315-31428	BEARING, cylindrical	1	

**C3**

FIG. 14 CLUTCH

REF. NO.	PART NO.	DESCRIPTION	Q'TY	REMARKS
29	2UJ-16357-00	ROD, push 2	1	
30	93511-32027	BALL	1	

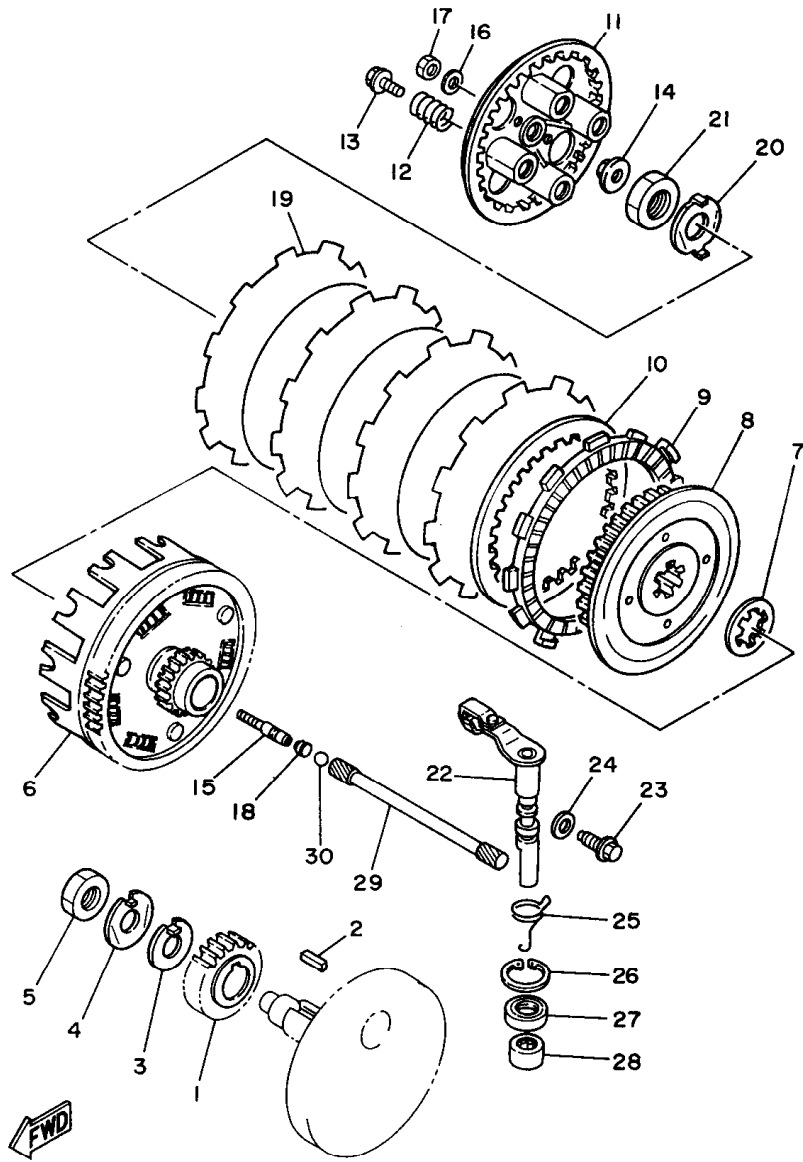

3LS7351-5140

**C4**

FIG. 15 TRANSMISSION

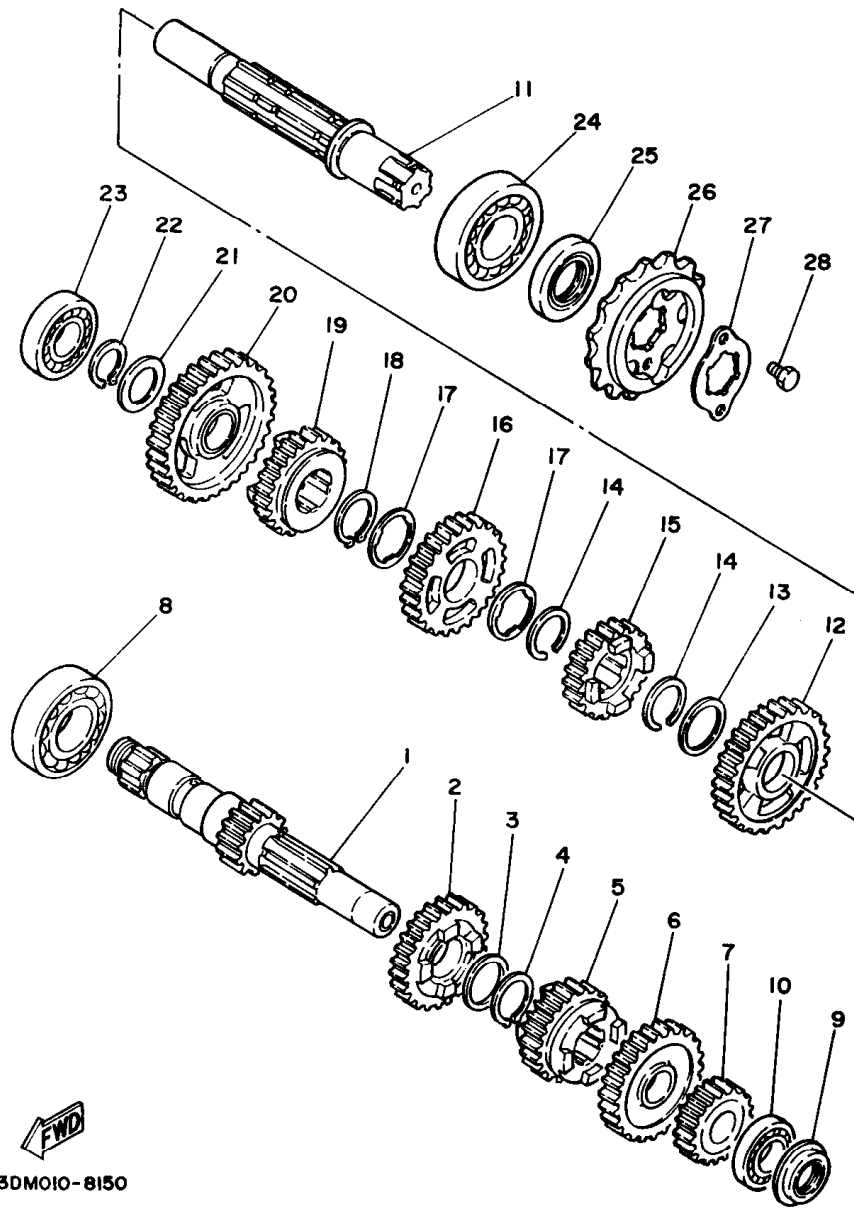

REF. NO.	PART NO.	DESCRIPTION	Q'TY	REMARKS
1	4DN-17411-00	AXLE, main	1	
2	3Y1-17141-00	GEAR, 4th pinion (26T)	1	
3	90201-22793	WASHER, plate	1	
4	93410-22039	CIRCLIP	1	
5	3Y1-17131-01	GEAR, 3rd pinion (23T)	1	
6	3Y1-17151-00	GEAR, 5th pinion (28T)	1	
7	3Y1-17121-01	GEAR, 2nd pinion (19T)	1	
8	93306-20541	BEARING (B6205)	1	
9	93101-17093	OIL SEAL	1	
10	93306-00302	BEARING	1	
11	3Y1-17402-00	DRIVE AXLE ASSY	1	
12	3Y1-17221-01	GEAR, 2nd wheel (32T)	1	
13	90201-253K0	WASHER, plate (T=1.0)	1	
14	93440-25084	CIRCLIP	2	
15	3Y1-17251-01	GEAR, 5th wheel	1	
16	3Y1-17231-01	GEAR, 3rd wheel (29T)	1	
17	90209-22191	WASHER	2	
18	93410-25010	CIRCLIP	1	
19	3Y1-17241-00	GEAR, 4th wheel (26T)	1	
20	3Y1-17211-00	GEAR, 1st wheel (37T)	1	
21	90201-20276	WASHER, plate (1.0T)	1	
22	99009-20400	CIRCLIP	1	
23	93306-00426	BEARING	1	
24	93306-30525	BEARING (B6305)	1	
25	93102-25208	OIL SEAL	1	
26	3DM-17460-00	SPROCKET, drive (16T)	1	
27	3Y1-17456-00	HOLDER, sprocket	1	
28	97027-06010	BOLT	2	

**C5**

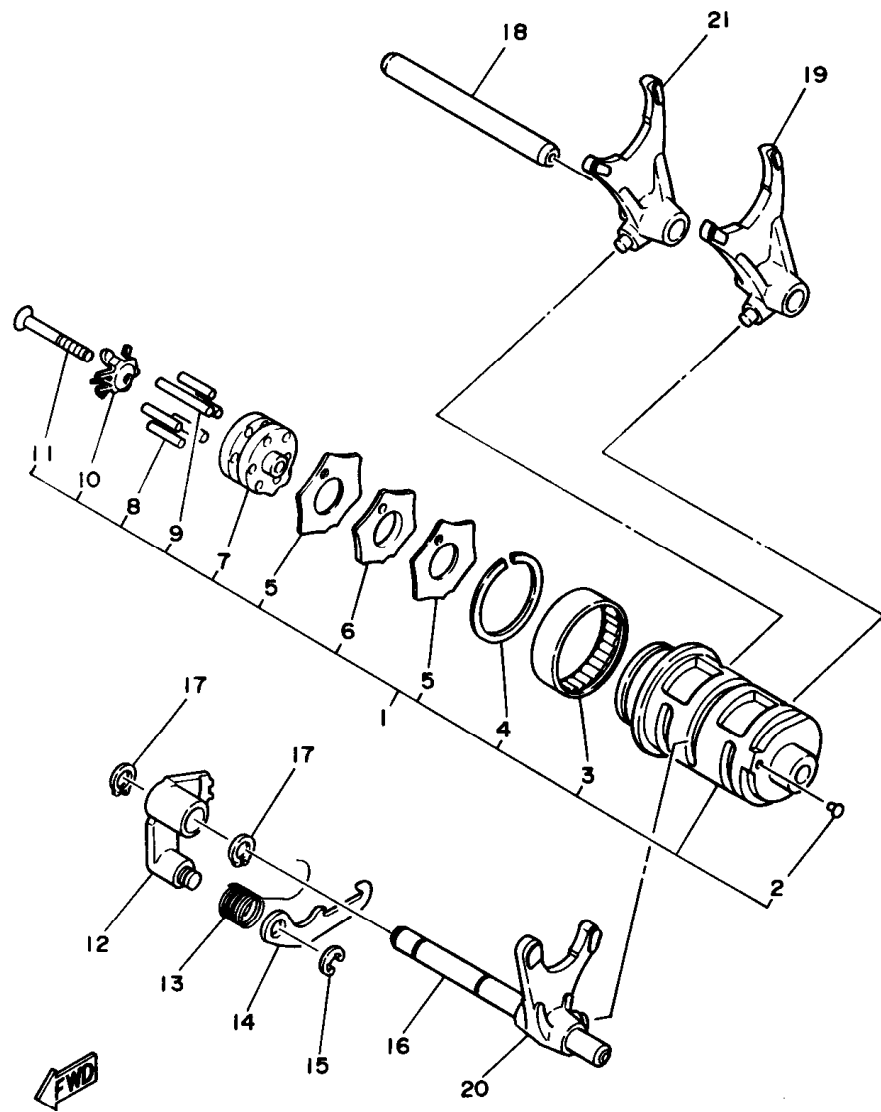

3DM010-8160

FIG. 16 SHIFT CAM. FORK

REF. NO.	PART NO.	DESCRIPTION	Q'TY	REMARKS
1	4DN-18540-00	SHIFT CAM ASSY	1	
2	136-18542-00	.POINT, neutral	1	
3	93315-23612	.BEARING, cylindrical	1	
4	93440-34025	.CIRCLIP	1	
5	3Y1-18161-00	.GUIDE, plate stopper	2	
6	3Y1-18141-00	.PLATE, stopper	1	
7	3Y1-18185-01	.SEGMENT	1	
8	93604-18100	.PIN, dowel	5	
9	93604-29151	.PIN, dowel	1	
10	2K9-18561-00	.PLATE, side 1	1	
11	98707-05035	.SCREW, flat head	1	
12	3Y1-18122-00	LEVER, shift 2	1	
13	90508-12430	SPRING, torsion	1	
14	2K7-18151-00	LEVER, shift 3	1	
15	99080-07600	CIRCLIP	1	
16	4DN-18531-00	BAR, shift fork guide 1	1	
17	99009-10400	CIRCLIP	2	
18	4DN-18535-00	BAR, shift fork guide 2	1	
19	4DN-18511-00	FORK, shift 1	1	
20	4DN-18512-00	FORK, shift 2	1	
21	4DN-18513-00	FORK, shift 3	1	



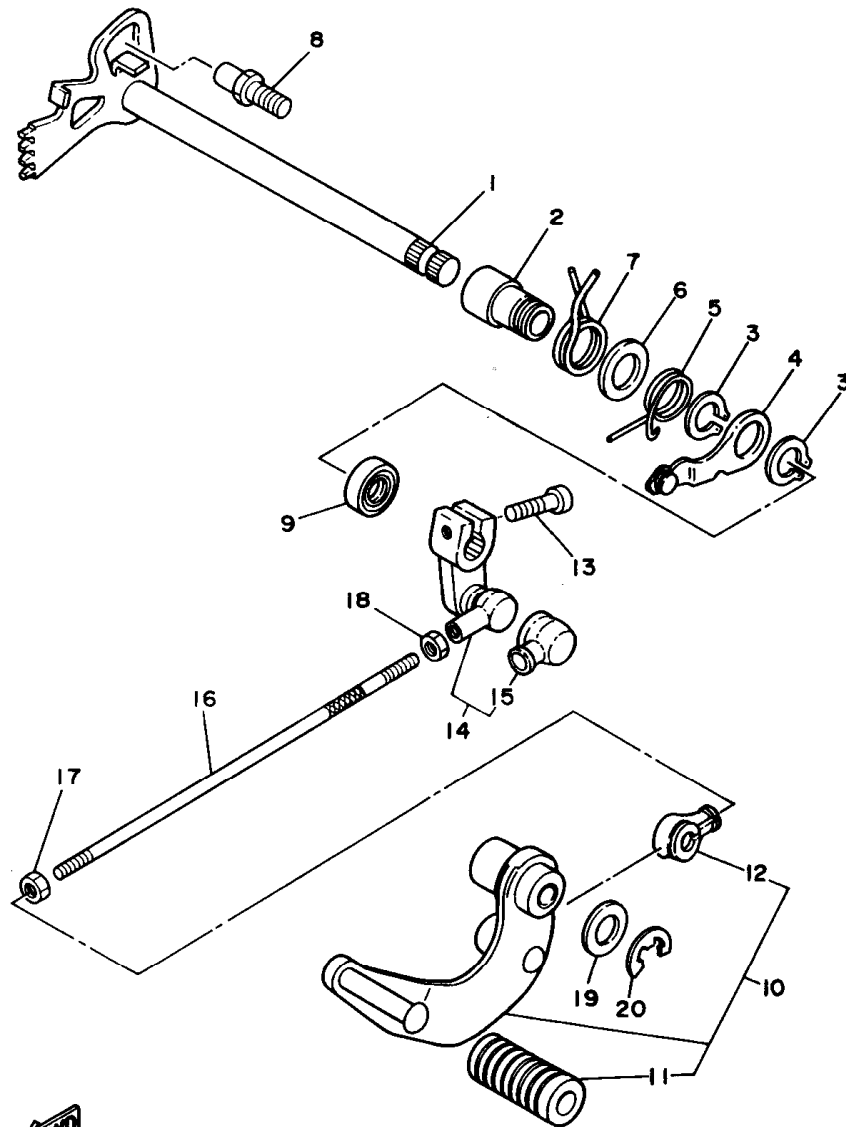

3LS1332-9170

FIG. 17 SHIFT SHAFT

REF. NO.	PART NO.	DESCRIPTION	Q'TY	REMARKS
1	2UJ-18101-01	SHIFT SHAFT ASSY	1	
2	90387-12787	COLLAR	1	
3	99009-17400	CIRCLIP	2	
4	3Y1-18140-00	STOPPER LEVER ASSY	1	
5	90508-26434	SPRING, torsion	1	
6	90201-17255	WASHER, plate	1	
7	90508-32374	SPRING, torsion	1	
8	4G0-18127-00	STOPPER, screw	1	
9	93102-12106	OIL SEAL (SD 12-22-5 HS)	1	
10	2UJ-18110-00	SHIFT PEDAL ASSY	1	
11	132-18113-01	.COVER, shift pedal	1	
12	2H9-18154-00	.COVER, dust	1	
13	97024-06020	BOLT	1	
14	2UJ-18130-00	SHIFT SHAFT ASSY	1	
15	2H9-18154-00	.COVER, dust	1	
16	2UJ-18115-02	ROD, shift	1	
17	90170-06228	NUT (COUNTER CLOCKWISE)	1	
18	95304-06700	NUT	1	
19	90201-124E4	WASHER, plate	1	
20	99009-12400	CIRCLIP	1	

FIG. 18 FRAME

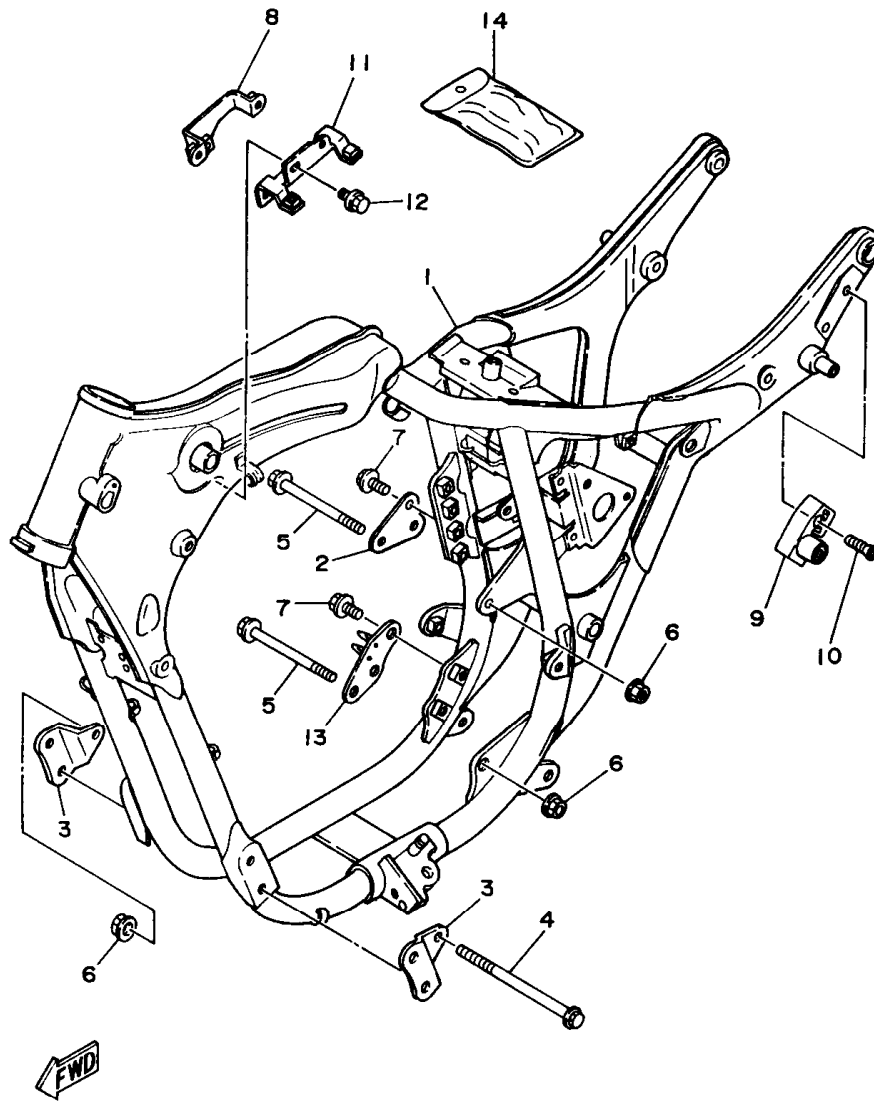

REF. NO.	PART NO.	DESCRIPTION	Q'TY	REMARKS
1	2UJ-21110-03-33	FRAME COMP.	1	UR YAMAHA BLACK FOR ITA.,CHE.
	3LS-21110-02-33	FRAME COMP.	1	UR YAMAHA BLACK FOR OTHERS
2	2UJ-21318-01	STAY, engine 5	1	
3	2UJ-21315-00	STAY, engine 2	2	
4	95814-08150	BOLT, flange	1	
5	95814-08110	BOLT, flange	2	
6	90179-08656	NUT	3	
7	95817-08016	BOLT, flange	4	
8	2UJ-21243-00	PLATE, bridge	1	
9	26H-21308-00	HELMET HANGER ASSY	1	
10	90149-06154	SCREW	1	
11	2UJ-2135Y-00	BRACKET, ignition coil	1	
12	98507-06012	BOLT, flange	1	
13	2UJ-21319-00	STAY, engine 6	1	
14	2UJ-28100-00	TOOL KIT	1	

3DN171-8181

C8

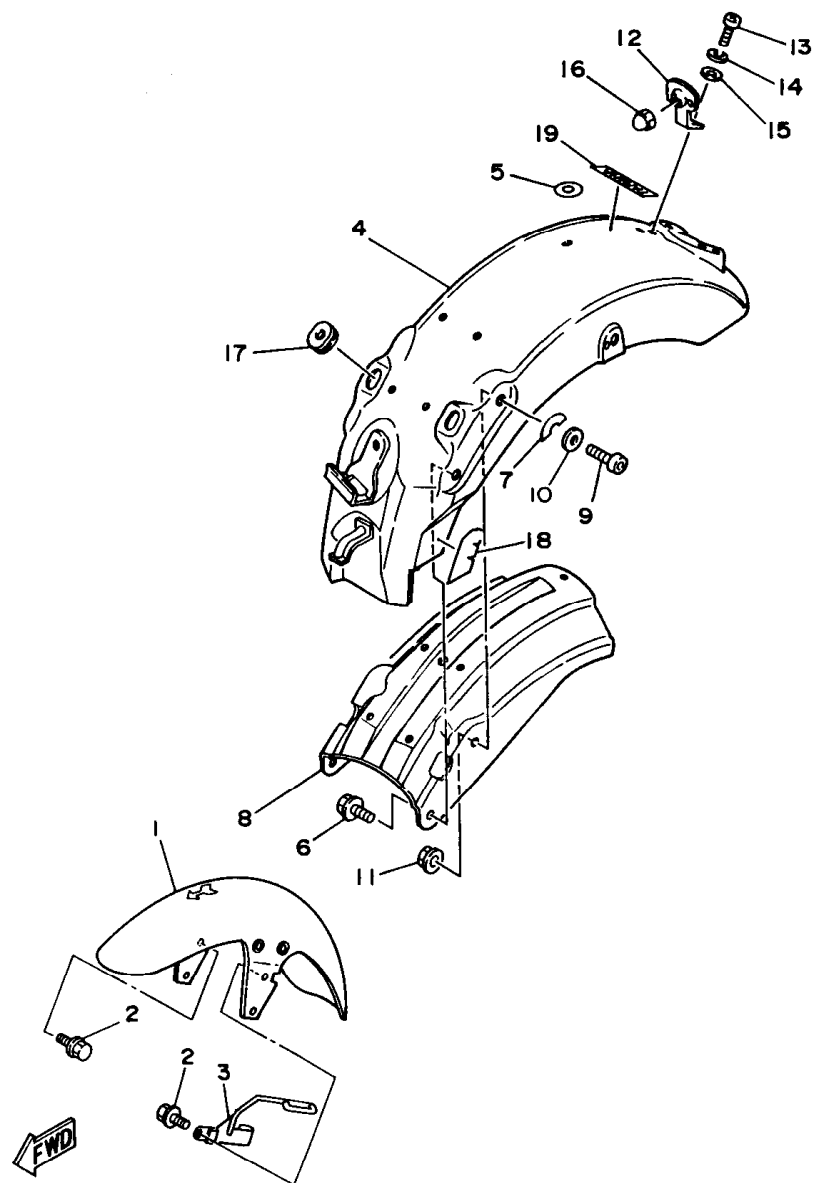

3LS7351-5190

FIG. 19 FENDER

REF. NO.	PART NO.	DESCRIPTION	Q'TY	REMARKS
1	2UJ-21510-00-P0	FRONT FENDER COMP.	1	UR DARK REDDISH GRAY METALLIC 1
	2UJ-21510-00-6G	FRONT FENDER COMP.	1	UR NEW YAMAHA BLACK
	2UJ-21510-00-MV	FRONT FENDER COMP. (XV250S)	1	UR RED-E SPARKLE
2	95024-08012	BOLT	4	
3	3DM-21597-00	HOLDER,wire 1	1	
4	2UJ-21610-00-P0	REAR FENDER COMP.	1	UR DARK REDDISH GRAY METALLIC 1
	2UJ-21610-00-6G	REAR FENDER COMP.	1	UR NEW YAMAHA BLACK
	2UJ-21610-00-MV	REAR FENDER COMP. (XV250S)	1	UR RED-E SPARKLE
5	2UJ-21735-00	SEAL 2	1	
6	95817-10020	BOLT, flange	2	
7	3DM-2173N-00	SEAL 4	2	
8	2UJ-21670-00	REINF. COMP.	1	
9	91317-10035	BOLT	2	
10	92907-10600	WASHER	2	
11	95707-10500	NUT, flange	2	
12	2UJ-21641-00	BRACKET, reflector	1	
13	98507-05010	SCREW, pan head	1	
14	92907-05100	WASHER, spring	1	
15	92907-05600	WASHER, plate	1	
16	95307-05800	NUT, cap	1	
17	90480-01502	GROMMET	2	
18	2UJ-2173M-01	SEAL 3	1	
19	99236-00080	EMBLEM, yamaha	1	UR
	99235-00080	EMBLEM, yamaha	1	UR FOR XV250S

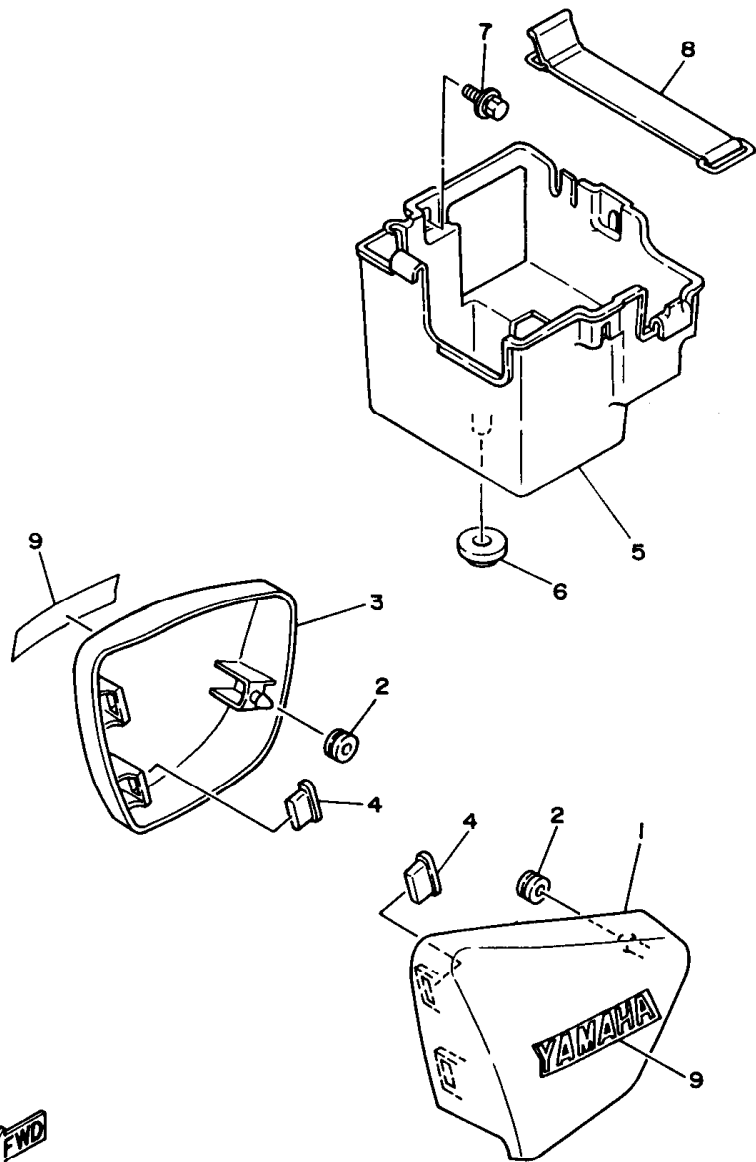

FIG. 20 SIDE COVER

REF. NO.	PART NO.	DESCRIPTION	Q'TY	REMARKS
1	2UJ-21711-00-P0	COVER, side 1	1	UR DARK REDDISH GRAY METALLIC 1
	2UJ-21711-00-6G	COVER, side 1	1	UR NEW YAMAHA BLACK
	2UJ-21711-00-MV	COVER, side 1 (XV250S)	1	UR RED-E SPARKLE
2	90480-13428	GROMMET	2	
3	2UJ-21721-00-P0	COVER, side 2	1	UR DARK REDDISH GRAY METALLIC 1
	2UJ-21721-00-6G	COVER, side 2	1	UR NEW YAMAHA BLACK
	2UJ-21721-00-MV	COVER, side 2 (XV250S)	1	UR RED-E SPARKLE
4	2N4-21717-00	DAMPER, side cover	4	
5	2UJ-2177G-00	BOX, battery	1	
6	90480-22362	GROMMET	1	
7	90119-06108	BOLT, with washer	2	
8	26H-82131-00	BAND, battery	1	
9	99236-00080	EMBLEM, yamaha	2	UR
	99235-00080	EMBLEM, yamaha	2	UR FOR XV250S



3DM010-8200

C10

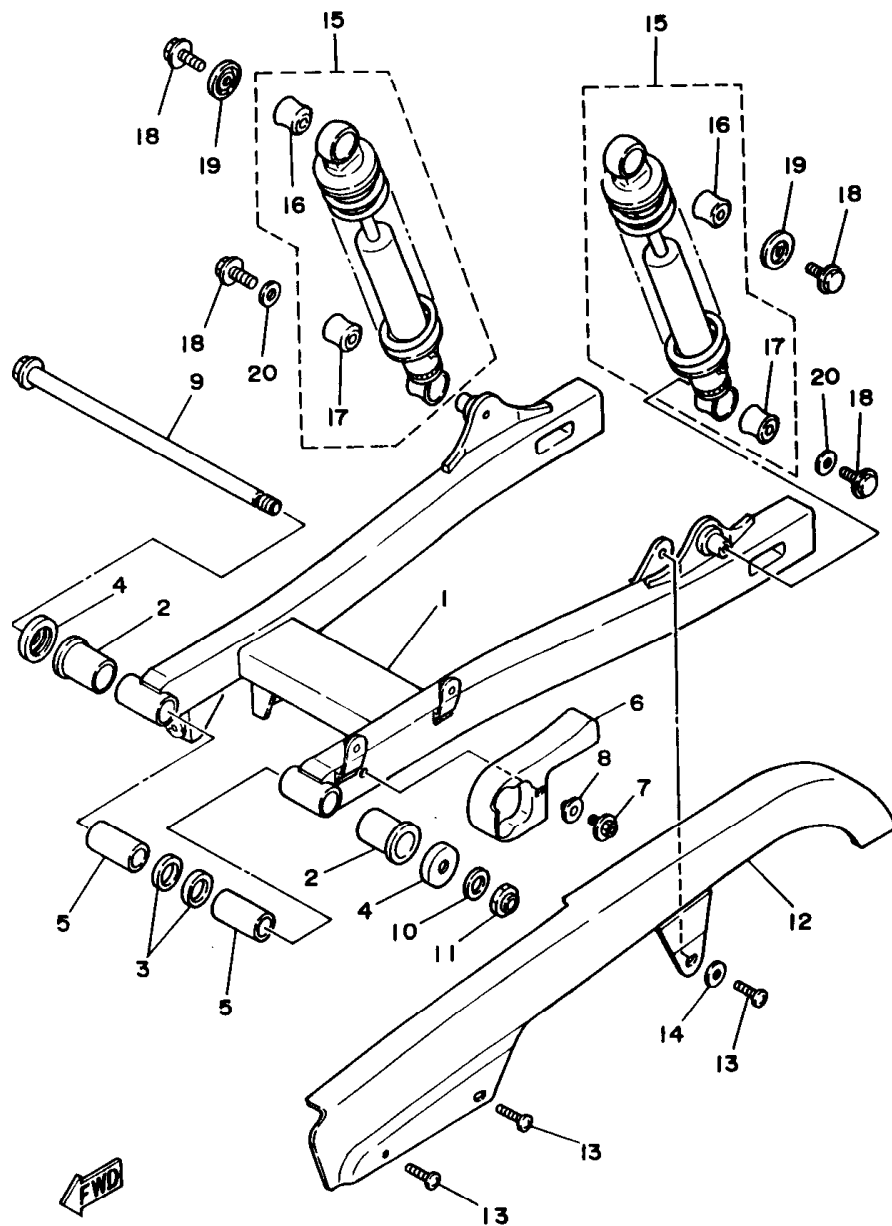

2UJ110-8210

FIG. 21 REAR ARM

REF. NO.	PART NO.	DESCRIPTION	Q'TY	REMARKS
1	3LS-22110-00-33	REAR ARM COMP.	1	YAMAHA BLACK
2	90386-18163	BUSH	2	
3	93109-18020	OIL SEAL	2	
4	55K-22129-00	COVER, thrust 2	2	
5	90380-12121	BUSH, solid	2	
6	55K-22151-01	SEAL, guard	1	
7	90119-05062	BOLT, with washer	1	
8	90209-06223	WASHER	1	
9	2UJ-22141-01	SHAFT, pivot	1	
10	92903-12200	WASHER, plain	1	
11	90185-12164	NUT, self-locking	1	
12	3LS-22311-00	CASE, chain	1	
13	98904-06012	SCREW, bind	3	
14	90201-065F3	WASHER, plate	1	
15	3DM-22210-00	SHOCK ABSORBER ASSY, rear	2	
16	447-22217-21	.DAMPER, shock absorber lower	1	
17	447-22216-20	.BUSH, rear shock absorber	1	
18	95024-08012	BOLT, flange	4	
19	1UJ-22243-00	WASHER 1	2	
20	90201-087G2	WASHER, plate	2	

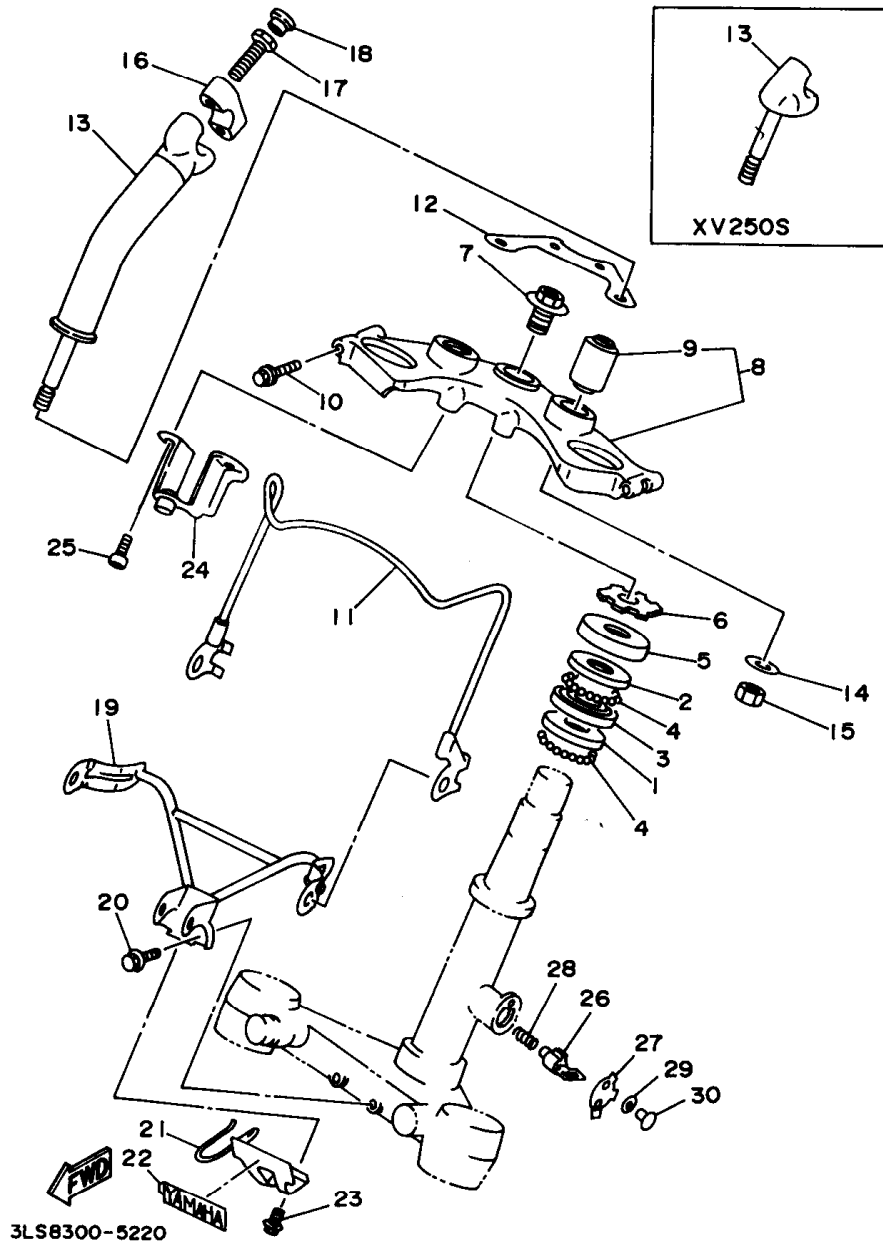
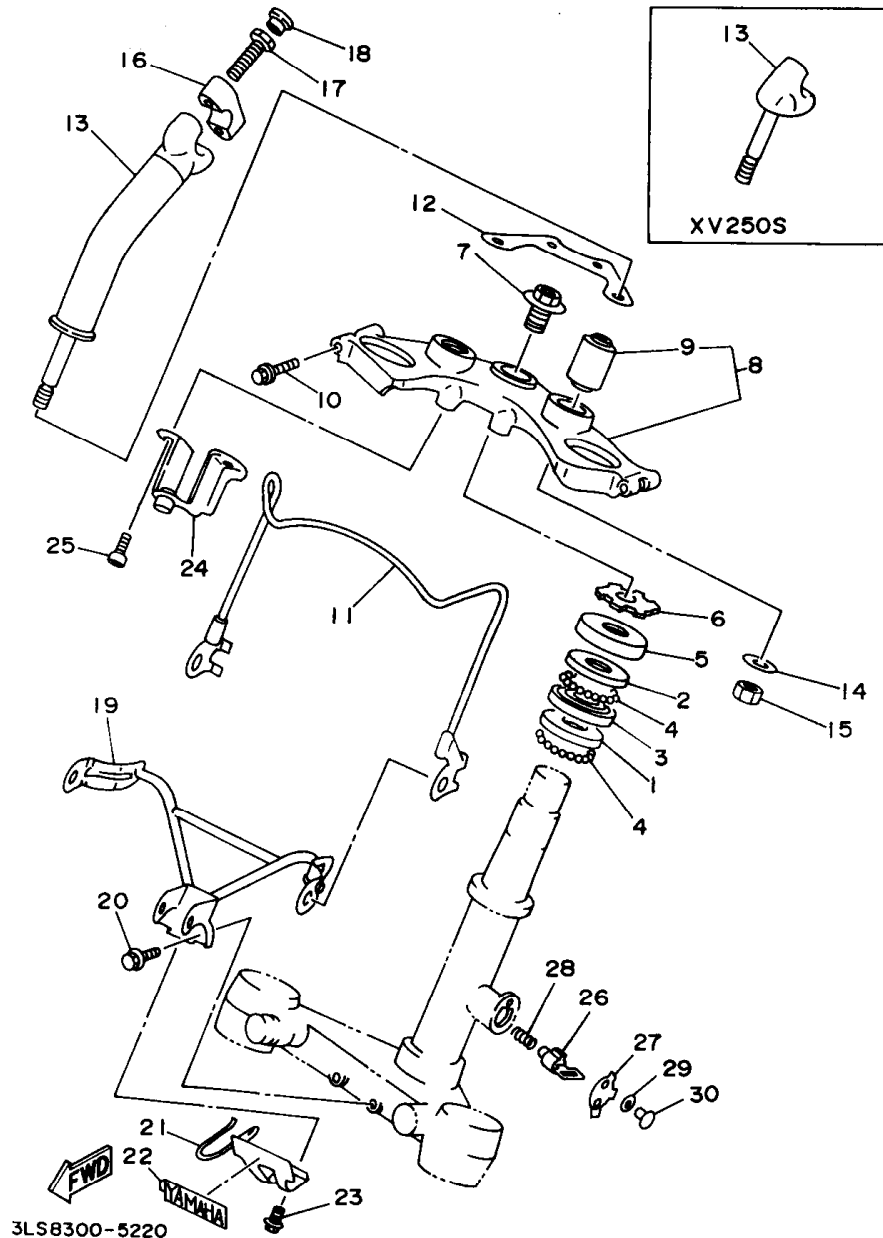

FIG. 22 STEERING

REF. NO.	PART NO.	DESCRIPTION	Q'TY	REMARKS
1	156-23412-00	RACE, ball 2	1	
2	183-23411-00	RACE, ball 1	1	
3	183-23412-00	RACE, ball 2	1	
4	93501-04011	BALL	38	
5	4K0-23415-00	COVER, ball race 1	1	
6	90179-25033	NUT	1	
7	90105-14102	BOLT, washer based	1	
8	2UJ-W2341-00-35	CROWN, handle	1	SILVER
9	5A8-23434-01	.HOLDER, damper	2	
10	95024-08040	BOLT, flange	2	
11	3DM-23164-00	STAY, light guard	1	
12	3DM-2317F-00	STAY 2	1	
13	3DM-23442-00	HOLDER, handle lower	2	UR
	42X-23442-00-38	HOLDER, handle lower	2	UR FOR XV250S
14	90201-105A2	WASHER, plate	2	
15	95617-10100	NUT, u	2	
16	4H7-23441-00-38	HOLDER, handle upper	2	CLEAR (WITH BUFF)
17	91314-08025	BOLT	4	
18	90338-08163	PLUG	4	
19	2UJ-23174-00	STAY, headlight	1	
20	95024-06016	BOLT	2	
21	2UJ-2317M-00	STAY 3	1	
22	3WF-2153E-40	EMBLEM, yamaha	1	
23	95024-06012	BOLT	1	
24	2UJ-2317E-00	STAY	1	
25	91317-06016	BOLT	2	
26	2A6-23408-00	STEERING LOCK ASSY	1	
27	3DM-23484-00	CAP, handle lock	1	

FIG. 22 STEERING



REF. NO.	PART NO.	DESCRIPTION	Q'TY	REMARKS
28	90502-09024	SPRING, conical	1	
29	90208-04029	WASHER, conical spring	1	
30	90269-04003	RIVET	1	

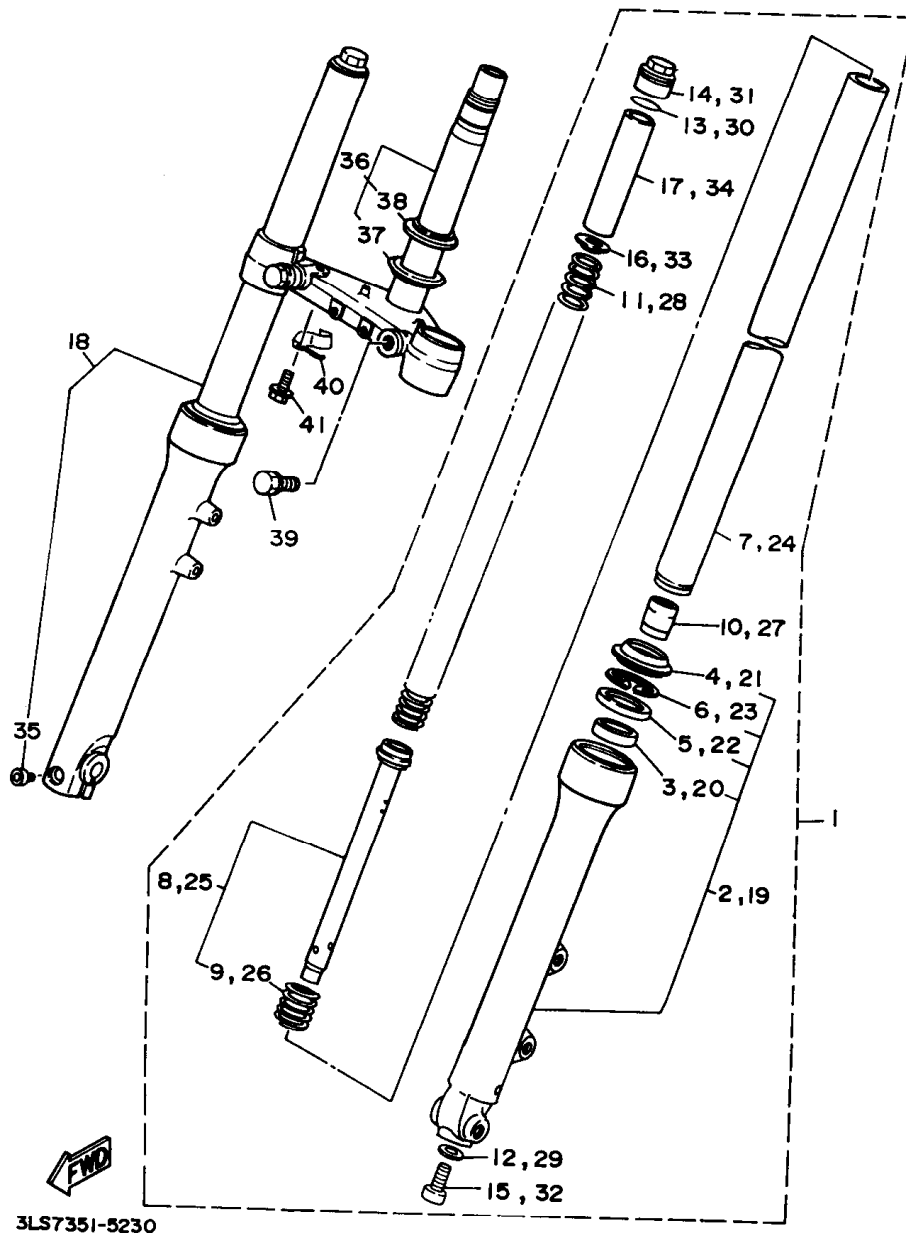

3LS7351-5230

FIG. 23 FRONT FORK

REF. NO.	PART NO.	DESCRIPTION	Q'TY	REMARKS
1	2UJ-23102-10	FRONT FORK ASSY (L.H)	1	
2	2UJ-23126-10	.TUBE, outer 1	1	
3	51Y-23125-00	..METAL, slide 1	1	
4	51Y-23144-00	..SEAL, dust	1	
5	51Y-23145-00	..OIL SEAL	1	
6	22W-23153-L0	..RING, snap	1	
7	2UJ-23110-00	.INNER TUBE COMP.1	1	
8	2UJ-23170-00	.CYLINDER COMP., front fork	1	
9	509-23151-L0	..SPRING, rebound	1	
10	39K-23173-00	.SPINDLE, taper	1	
11	2UJ-23141-00	.SPRING, front fork	1	
12	509-23158-L0	.GASKET	1	
13	3J2-23114-00	.O-RING	1	
14	2JN-23111-00	.BOLT, cap	1	
15	278-23181-50	.BOLT, hexagon socket head	1	
16	3DM-23149-10	.WASHER, spring upper	1	
17	58T-23118-L0	.SPACER	1	
18	2UJ-23103-10	FRONT FORK ASSY (R.H)	1	
19	2UJ-23136-10	.TUBE, outer 2	1	
20	51Y-23125-00	..METAL, slide 1	1	
21	51Y-23144-00	..SEAL, dust	1	
22	51Y-23145-00	..OIL SEAL	1	
23	22W-23153-L0	..RING, snap	1	
24	2UJ-23110-00	.INNER TUBE COMP. 1	1	
25	2UJ-23170-00	.CYLINDER COMP., front fork	1	
26	509-23151-L0	..SPRING, rebound	1	
27	39K-23173-00	.SPINDLE, taper	1	
28	2UJ-23141-00	.SPRING, front fork	1	

**C14**



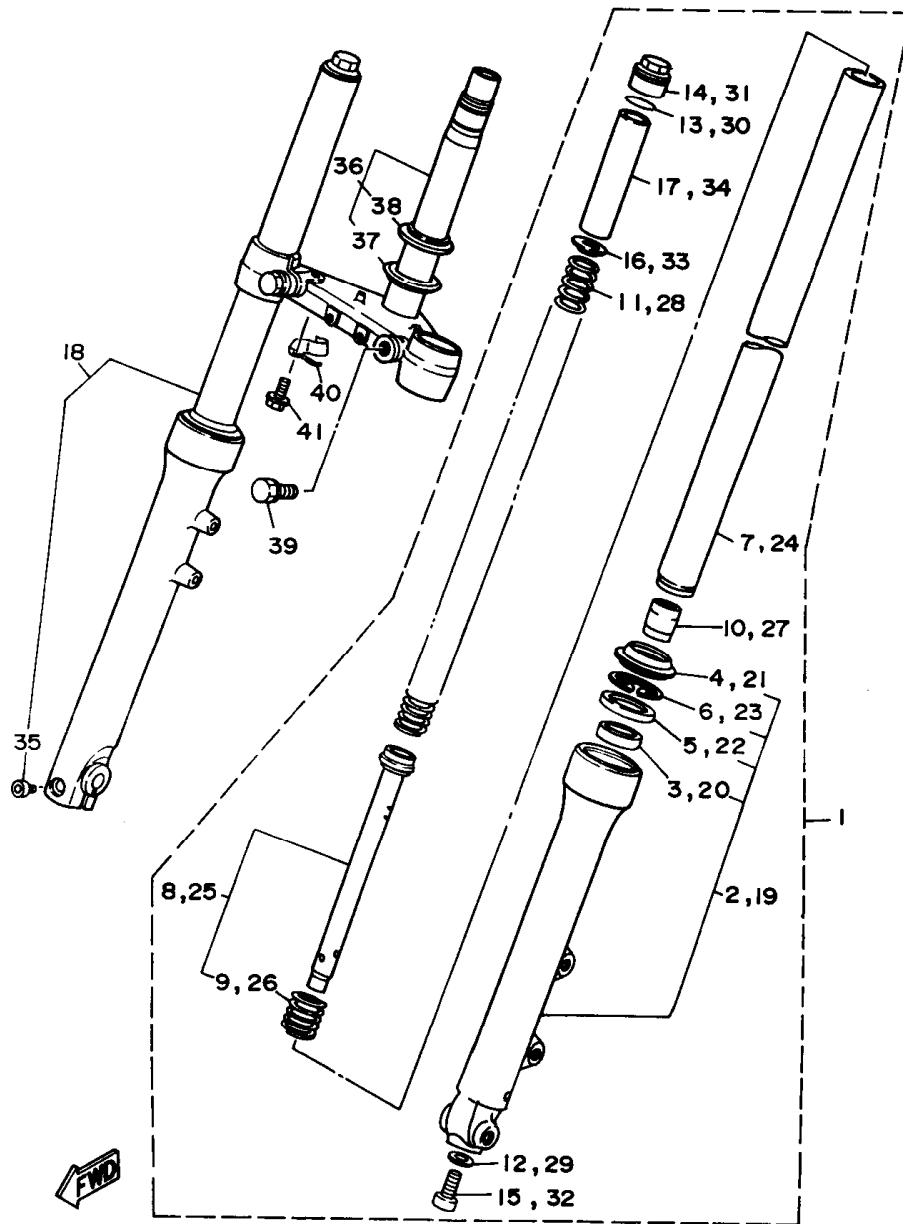

3LS7351-5230

FIG. 23 FRONT FORK

REF. NO.	PART NO.	DESCRIPTION	Q'TY	REMARKS
29	509-23158-L0	.GASKET	1	
30	3J2-23114-00	.O-RING	1	
31	2JN-23111-00	.BOLT, cap	1	
32	278-23181-50	.BOLT, hexagon socket head	1	
33	3DM-23149-10	.WASHER, spring upper	1	
34	58T-23118-L0	.SPACER	1	
35	91311-08035	.BOLT	1	
36	3LS-23340-00	UNDER BRACKET COMP.	1	
37	164-23462-00	.SEAL, steering	1	
38	156-23411-00	.RACE, ball 1	1	
39	2UJ-23346-00	BOLT 1	2	
40	3DM-25886-10	HOLDER, brake hose	1	
41	98507-06010	BOLT, flange	1	

**C15**

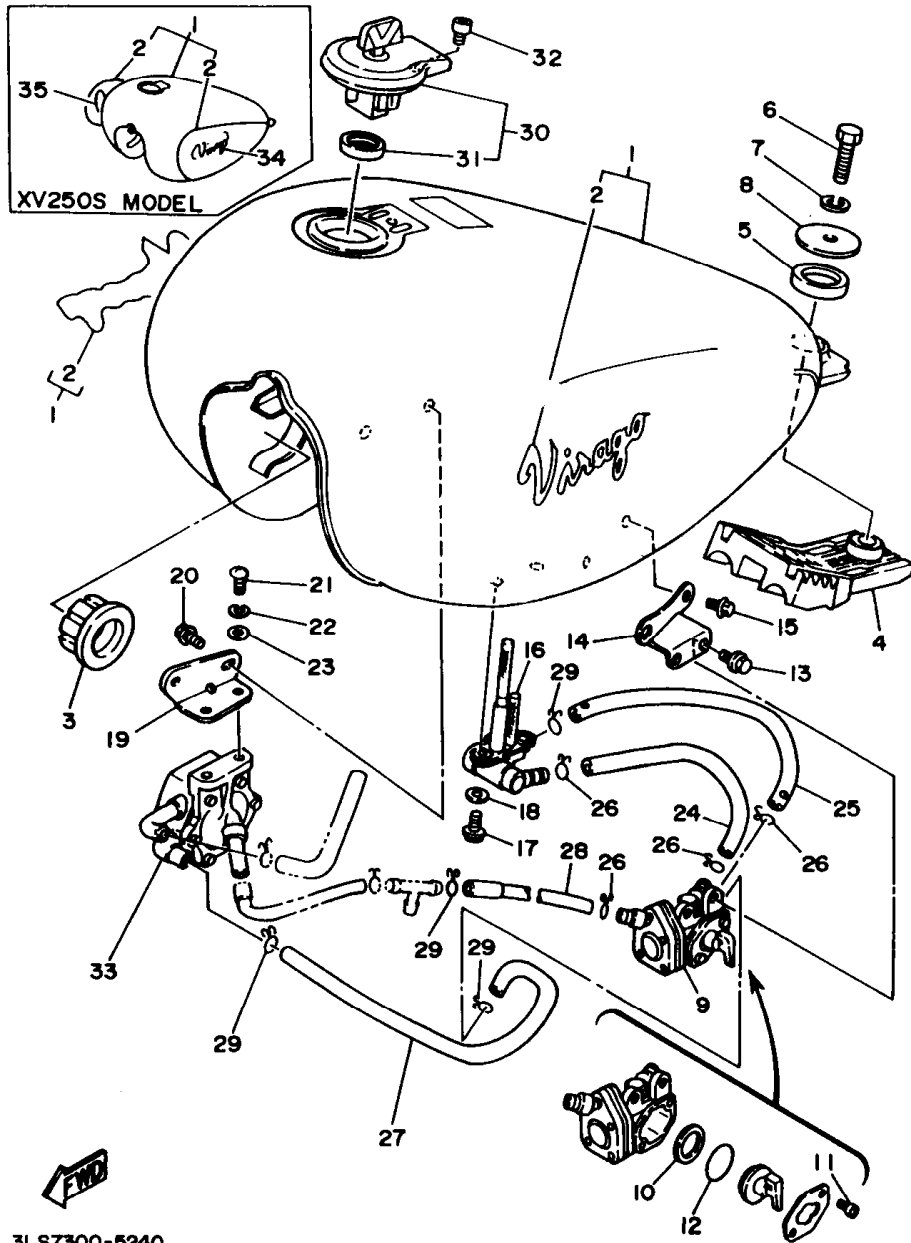

3LS7300-5240

FIG. 24 FUEL TANK

REF. NO.	PART NO.	DESCRIPTION	Q'TY	REMARKS
1	2UJ-24110-00-X5	FUEL TANK COMP.	1	UR NEW YAMAHA BLACK
	2UJ-24110-00-W1	FUEL TANK COMP.	1	UR DARK REDDISH GRAY METALLIC 1
	3DM-24110-00-08	FUEL TANK COMP. (XV250S)	1	UR RED-E SPARKLE/SALT LAKE SILVER
2	3LS-24161-30	.EMBLEM 1	2	UR FOR DRGM1
	3DM-24161-10	.EMBLEM 1	2	UR FOR NYB
	3DM-24240-70	.GRAPHIC SET (XV250S)	1	UR FOR RES
3	4H7-24181-00	DAMPER, locating 1	2	
4	2UJ-24182-00	DAMPER, locating 2	1	
5	42X-24183-00	DAMPER, locating 3	1	
6	97007-08035	BOLT	1	
7	92907-08100	WASHER, spring	1	
8	90201-08569	WASHER, plate	1	
9	2UJ-24500-00	FUEL COCK ASSY 1	1	
10	3H3-24523-00	.VALVE	1	
11	98503-03008	.SCREW, pan head	2	
12	1JK-24534-00	.SEAL, cock	1	
13	95024-06010	BOLT, flange	2	
14	2UJ-24544-01	BRACKET, fuel cock	1	
15	95024-06010	BOLT, flange	2	
16	2UJ-24560-00	FILTER ASSY	1	
17	90149-06011	SCREW	2	
18	90202-05193	WASHER, plate	2	
19	2UJ-24491-01	BRACKET, fuel pump	1	
20	95024-06010	BOLT, flange	2	
21	98507-06012	SCREW, pan head	2	
22	92907-06100	WASHER, spring	2	
23	92907-06600	WASHER, plate	2	
24	90445-11501	HOSE	1	

D2

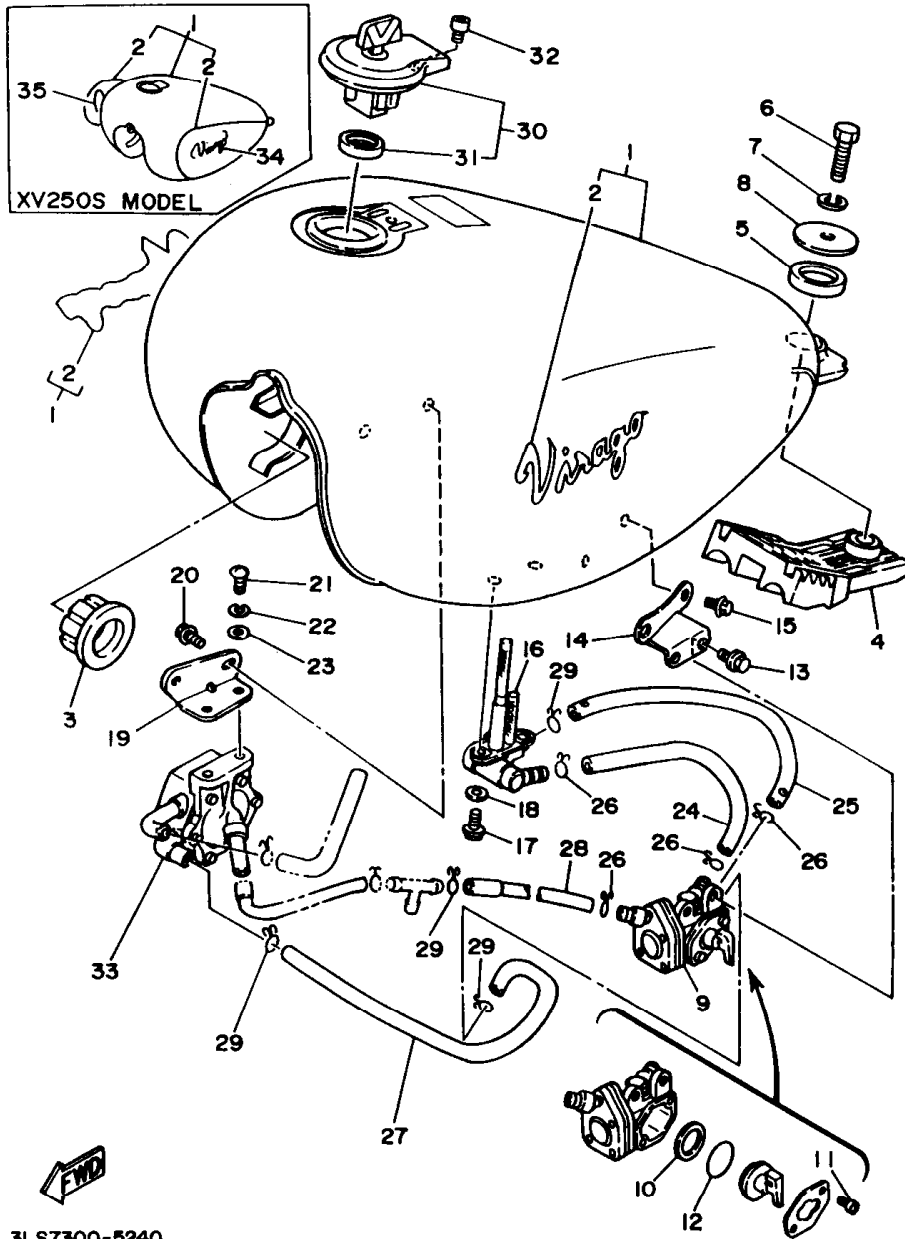

FIG. 24 FUEL TANK

REF. NO.	PART NO.	DESCRIPTION	Q'TY	REMARKS
25	90445-11754	HOSE	1	
26	90467-10008	CLIP	4	
27	2UJ-24312-01	PIPE 2	1	
28	2UJ-24313-00	PIPE 3	1	
29	90467-10008	CLIP	4	
30	4X7-24602-04	CAP ASSY	1	
31	4X7-24612-00	.GASKET, cap	1	
32	91317-05010	BOLT	1	
33	3DM-13910-00	FUEL PUMP ASSY	1	
34	3DM-24161-30	EMBLEM 1	1	FOR XV250S
35	3DM-24162-30	EMBLEM 2	1	FOR XV250S

3LS7300-5240

**D3**

FIG. 25 SEAT

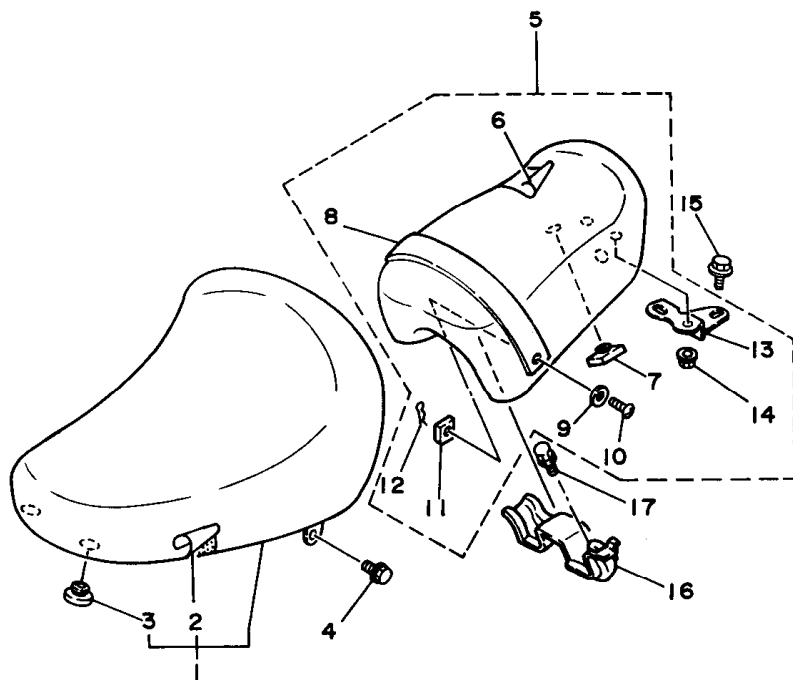

REF. NO.	PART NO.	DESCRIPTION	Q'TY	REMARKS
1	2UJ-24710-00	SINGLE SEAT ASSY	1	UR
	3DM-24710-10	SINGLE SEAT ASSY (XV250S)	1	UR
2	2UJ-24731-00	.COVER, seat	1	UR
	3DM-24731-10	.COVER, seat (XV250S)	1	UR
3	18A-24724-00	.DAMPER, seat	4	
4	95807-06016	BOLT, flange	2	
5	2UJ-24750-00	TANDEM SEAT ASSY	1	UR
	3DM-24750-10	TANDEM SEAT ASSY (XV250S)	1	UR
6	2UJ-24751-00	.COVER, tandem seat	1	UR
	3DM-24750-10	.COVER, tandem seat (XV250S)	1	UR
7	509-24724-00	.DAMPER, seat	4	
8	2UJ-24754-00	.HOOK, seat	1	
9	1WG-24712-00	.PLATE	2	
10	47X-24739-00	.BOLT, seat fitting	2	
11	90173-06015	.NUT, square	2	
12	90468-10050	.CLIP	2	
13	2UJ-2471A-00	.STAY, seat	1	
14	95707-06500	.NUT, flange	2	
15	95024-08012	BOLT, flange	1	
16	2UJ-2475H-00	BRACKET, seat lever 1	1	
17	95027-06012	BOLT	2	



3DM010-8250

D4

FIG. 26 FRONT WHEEL

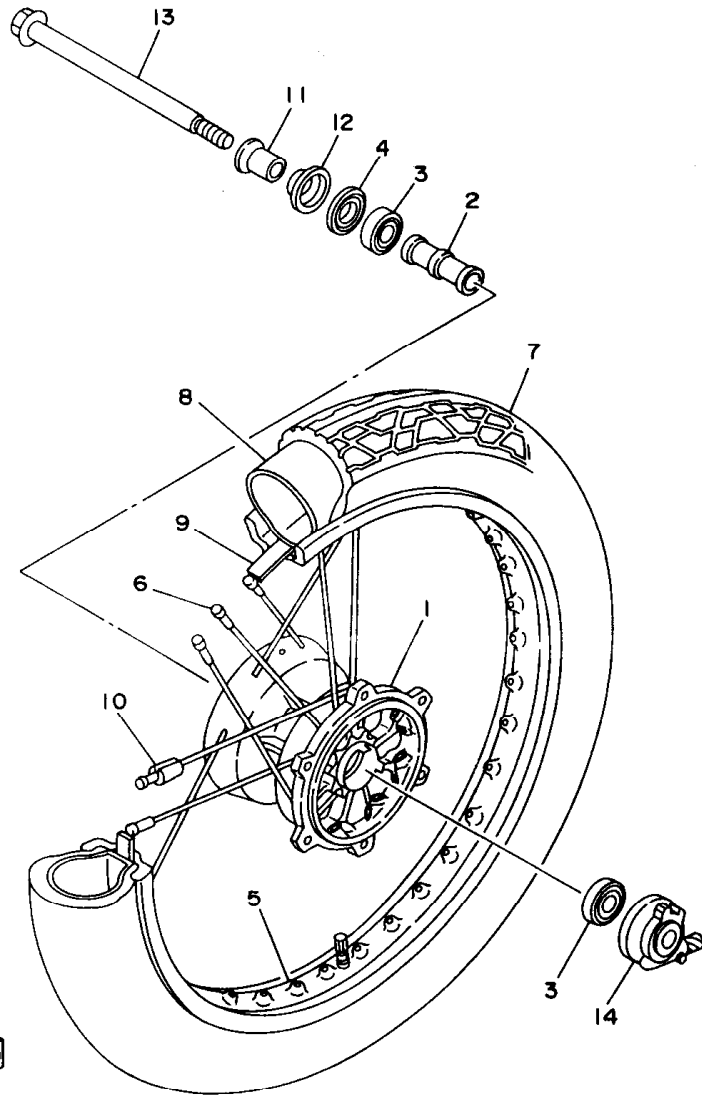

REF. NO.	PART NO.	DESCRIPTION	Q'TY	REMARKS
1	4DN-25111-20-35	HUB, front	1	SILVER
2	90560-15240	SPACER	1	
3	93306-20209	BEARING (B6202)	2	
4	93102-20281	OIL SEAL	1	
5	94416-18523	RIM (1.60-18)	1	
6	3DM-25104-00	SPOKE SET, front	1	
7	94130-185T4	TIRE (3.00-18-4PR NF27,47p)	1	INOUE
8	94227-18195	TUBE (2.75-18)	1	DUNLOP
9	94345-18081	BAND, rim (4.50-18)	1	INOUE
10	156-25398-00	BALANCER, wheel	1	UN
11	90387-15600	COLLAR	1	
12	322-25118-00	COVER, hub dust	1	
13	10W-25381-00	AXLE, wheel	1	
14	4DN-25190-01	GEAR UNIT ASSY	1	

4DN2010-3260

**D5**

FIG. 27 FRONT BRAKE CALIPER

REF. NO.	PART NO.	DESCRIPTION	Q'TY	REMARKS
1	3LP-2582T-00	DISC, brake (LEFT)	1	
2	90109-081F0	BOLT	6	
3	4HM-2580T-00	CALIPER ASSY (RIGHT)	1	
4	4FU-W0057-50	.PISTON ASSY, caliper	1	
5	4FU-W0047-50	..CALIPER SEAL KIT	1	
6	5R2-25937-00	.BOOT 2	1	
7	3YX-25937-00	.BOOT	1	
8	4HM-W0045-00	.BRAKE PAD KIT	1	
9	4BP-25919-00	.SUPPORT, pad	2	
10	3YX-25929-00	.SPRING	1	
11	51L-W0048-00	.BLEED SCREW KIT	1	
12	90105-10638	BOLT, washer based	2	

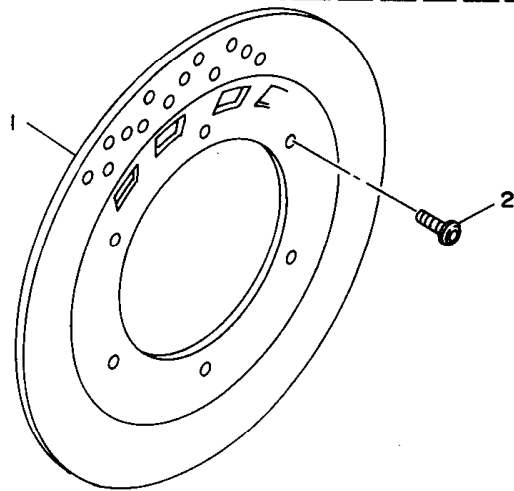
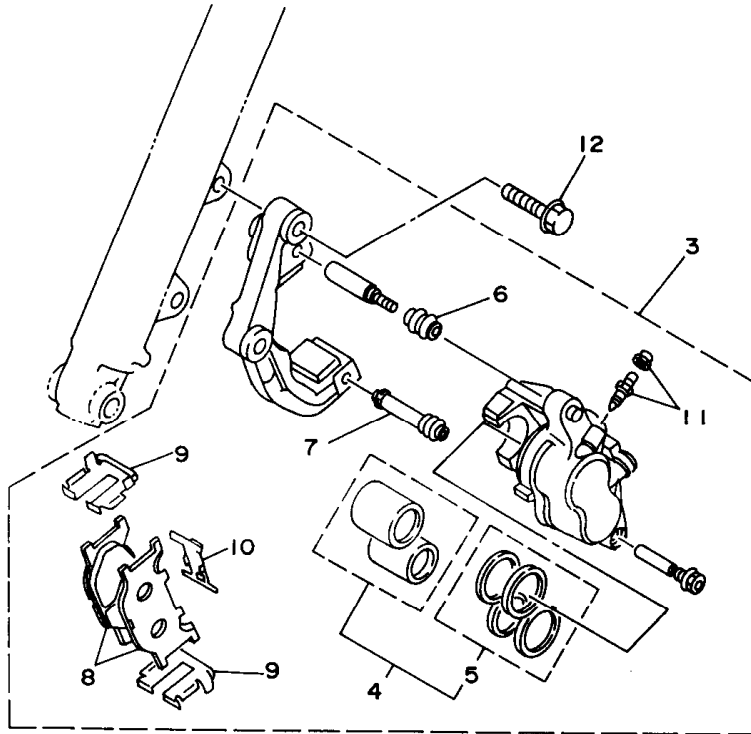

3LP9010-4290

**D6**

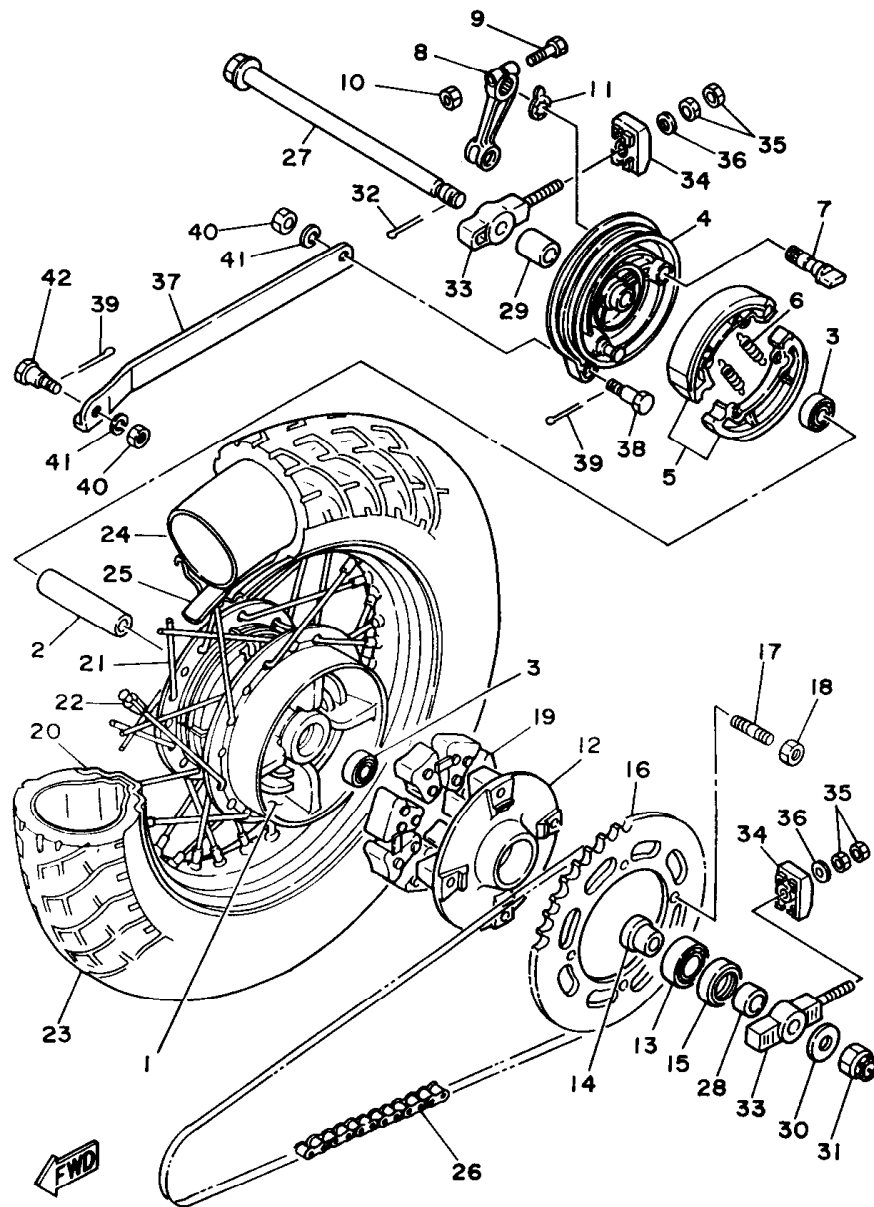

3LV7700-5280

FIG. 28 REAR WHEEL

REF. NO.	PART NO.	DESCRIPTION	Q'TY	REMARKS
1	2UJ-25311-10	HUB, rear	1	
2	2UJ-25317-00	SPACER, bearing	1	
3	93306-20226	BEARING	2	
4	2RH-25321-10	PLATE, brake shoe	1	
5	3LS-W2536-00	BRAKE SHOE SET	1	
6	90506-15260	SPRING, tension	2	
7	2RH-25351-00	CAMSHAFT	1	
8	5H0-25355-00	LEVER, camshaft	1	
9	90101-06765	BOLT	1	
10	95304-06600	NUT	1	
11	3Y6-2533A-01	PLATE, indicator	1	
12	5Y1-25366-10	CLUTCH, hub	1	
13	93306-30416	BEARING (B6304RS)	1	
14	2UJ-25377-00	COLLAR, wheel	1	
15	93106-30029	OIL SEAL	1	
16	4DN-25445-20	SPROCKET, driven (45T)	1	
17	90116-10485	BOLT, stud	4	
18	95604-10200	NUT	4	
19	5Y1-25364-00	DAMPER	4	
20	94427-15476	RIM	1	
21	2UJ-25304-00	SPOKE SET, rear	1	
22	156-25398-00	BALANCER, wheel	1	UN
23	94113-154W1	TIRE (130/90-15 M/C)	1	INOUE
24	94213-15265	TUBE (130/90-15, 140/80-15)	1	INOUE
25	94313-15154	BAND, rim	1	INOUE
26	94581-18114	CHAIN (DID520V6 114LE)	1	
27	2UJ-25381-00	AXLE, wheel	1	
28	2UJ-25383-00	COLLAR, wheel	1	

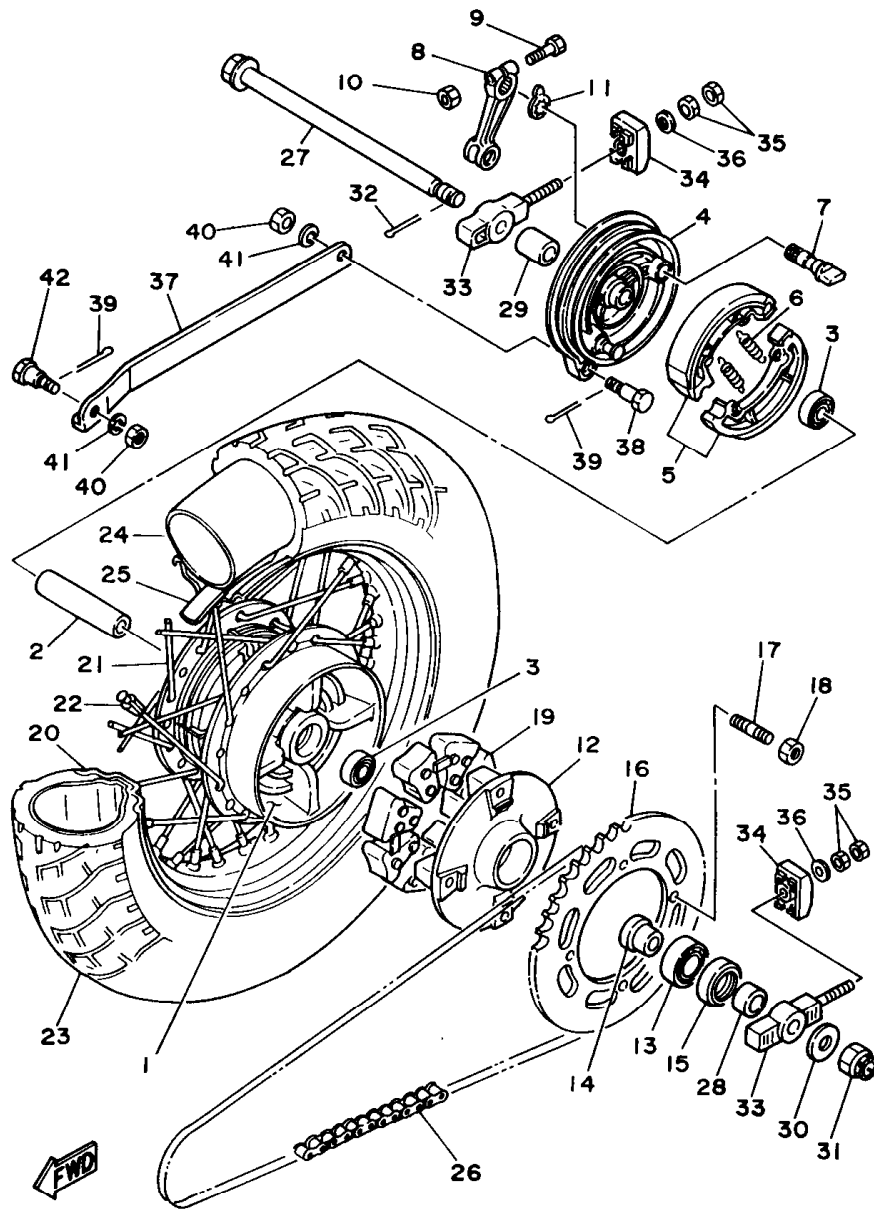

3LV7700-5280

FIG. 28 REAR WHEEL

REF. NO.	PART NO.	DESCRIPTION	Q'TY	REMARKS
29	90387-153U1	COLLAR	1	
30	92903-14200	WASHER, plain	1	
31	90171-14056	NUT, castle	1	
32	91401-30030	PIN, cotter	1	
33	2UJ-25388-00	PULLER, chain 1	2	
34	55K-2539F-00	PLATE 1	2	
35	95304-08600	NUT	4	
36	92990-08600	WASHER, plate	2	
37	2UJ-25371-00	BAR, tension	1	
38	90109-081G5	BOLT	1	
39	91401-20020	PIN, cotter	2	
40	95304-08700	NUT	2	
41	92990-08100	WASHER, spring	2	
42	90109-081G6	BOLT	1	

**D8**



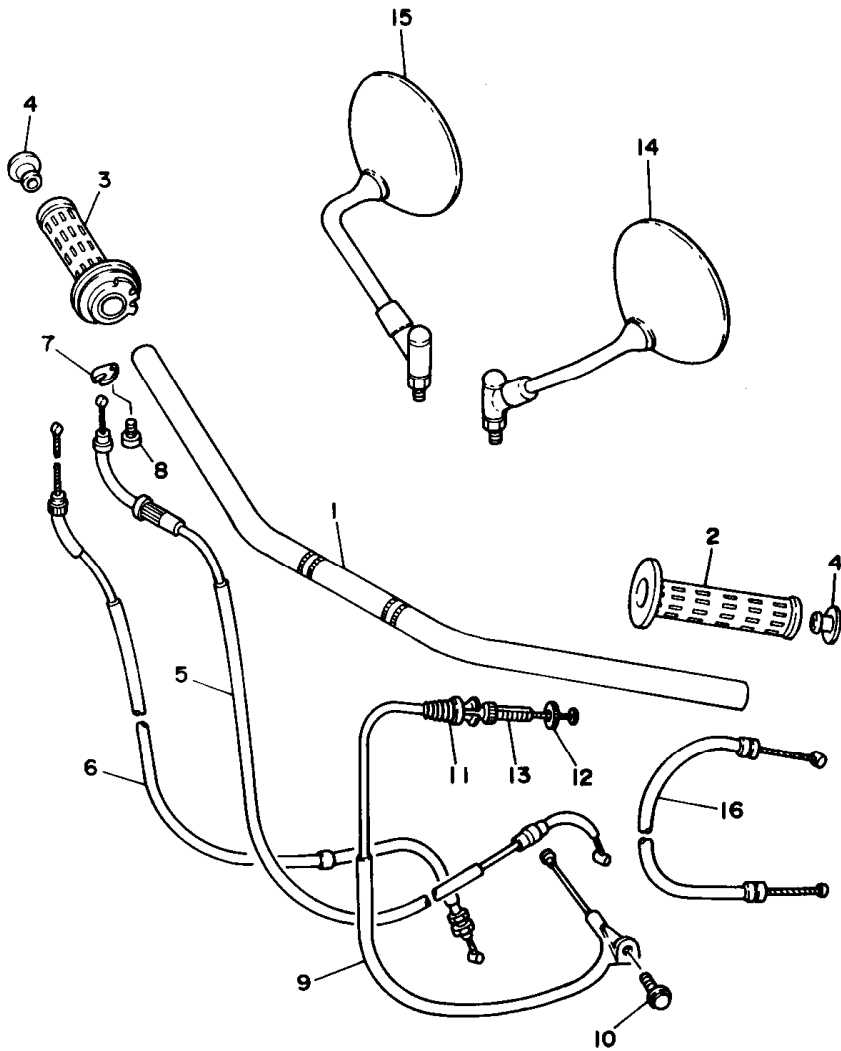

FIG. 29 STEERING HANDLE. CABLE

REF. NO.	PART NO.	DESCRIPTION	Q'TY	REMARKS
1	2NT-26111-00	HANDLEBAR	1	
2	42X-26241-00	GRIP (LEFT)	1	
3	1FK-26240-00	GRIP ASSY	1	
4	26H-2628J-00	CAP, grip	2	
5	3DM-26311-01	CABLE, throttle 1	1	
6	3DM-26312-01	CABLE, throttle 2	1	
7	5H0-26393-00	HOLDER	1	
8	98507-05008	SCREW, pan head	1	
9	3DM-26335-00	CABLE, clutch	1	
10	95027-06012	BOLT, flange	1	
11	1E6-26342-00	BOOT, cable	1	
12	90179-08148	NUT	1	
13	90123-08046	BOLT	1	
14	1J7-26290-F0	BACK MIRROR ASSY (LEFT)	1	
15	1J7-26290-G0	BACK MIRROR AASY (RIGHT)	1	
16	3DM-26331-00	CABLE, starter 1	1	



3LS1332-9290

**D9**

FIG. 30 STEERING HANDLE, CABLE (XV250S)

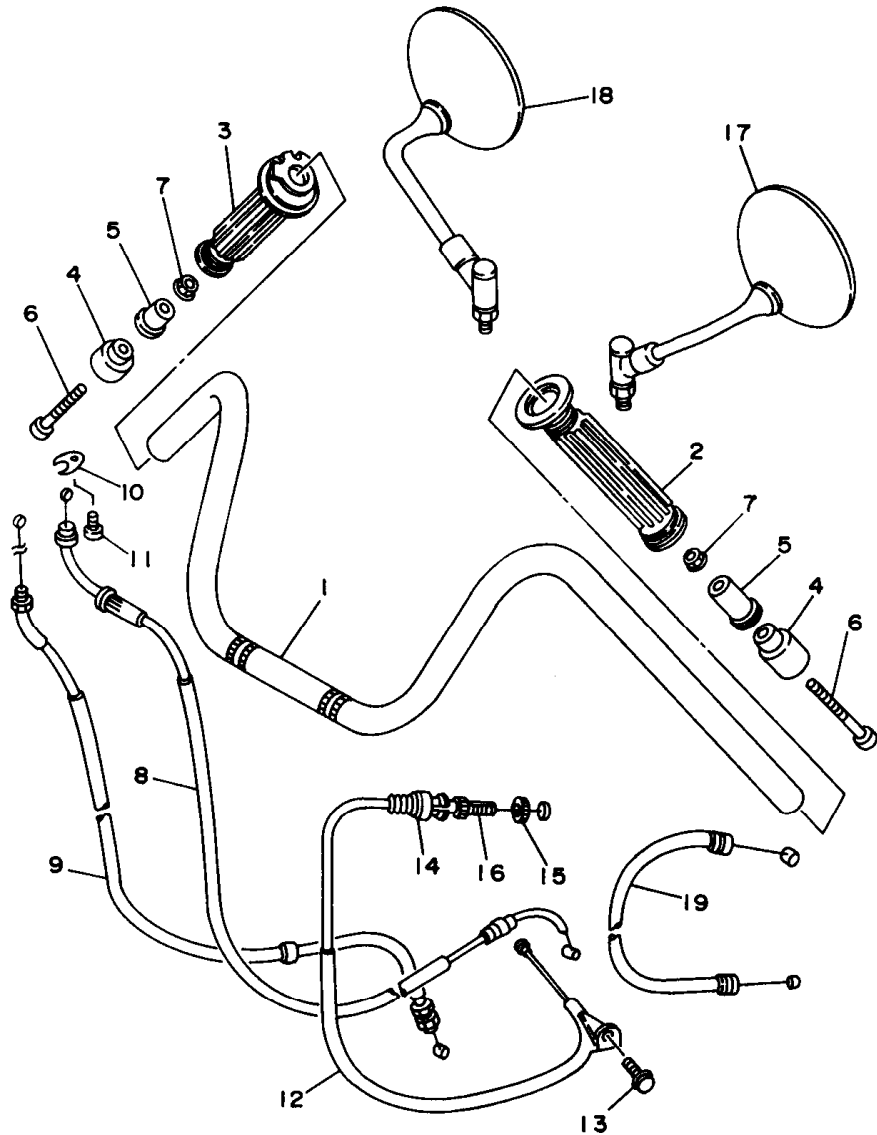

REF. NO.	PART NO.	DESCRIPTION	Q'TY	REMARKS
1	2UJ-26111-01	HANDLEBAR	1	
2	21A-26241-00	GRIP	1	
3	2UJ-26240-00	GRIP ASSY	1	
4	42N-26246-00	END, grip	2	
5	1FW-2622F-01	DAMPER, locating 1	2	
6	91314-06075	BOLT	2	
7	90179-06403	NUT	2	
8	2UJ-26311-01	CABLE, throttle 1	1	
9	2UJ-26312-01	CABLE, throttle 2	1	
10	5H0-26393-00	HOLDER	1	
11	98507-05008	SCREW, pan head	1	
12	2UJ-26335-01	CABLE, clutch	1	
13	95027-06012	BOLT, flange	1	
14	1E6-26342-00	BOOT, cable	1	
15	90179-08148	NUT	1	
16	90123-08046	BOLT	1	
17	1J7-26290-F0	BACK MIRROR ASSY (LEFT)	1	
18	1J7-26290-G0	BACK MIRROR AASY (RIGHT)	1	
19	2UJ-26331-01	CABLE, starter 1	1	



3LS935 1-5300

FIG. 31 FRONT MASTER CYLINDER

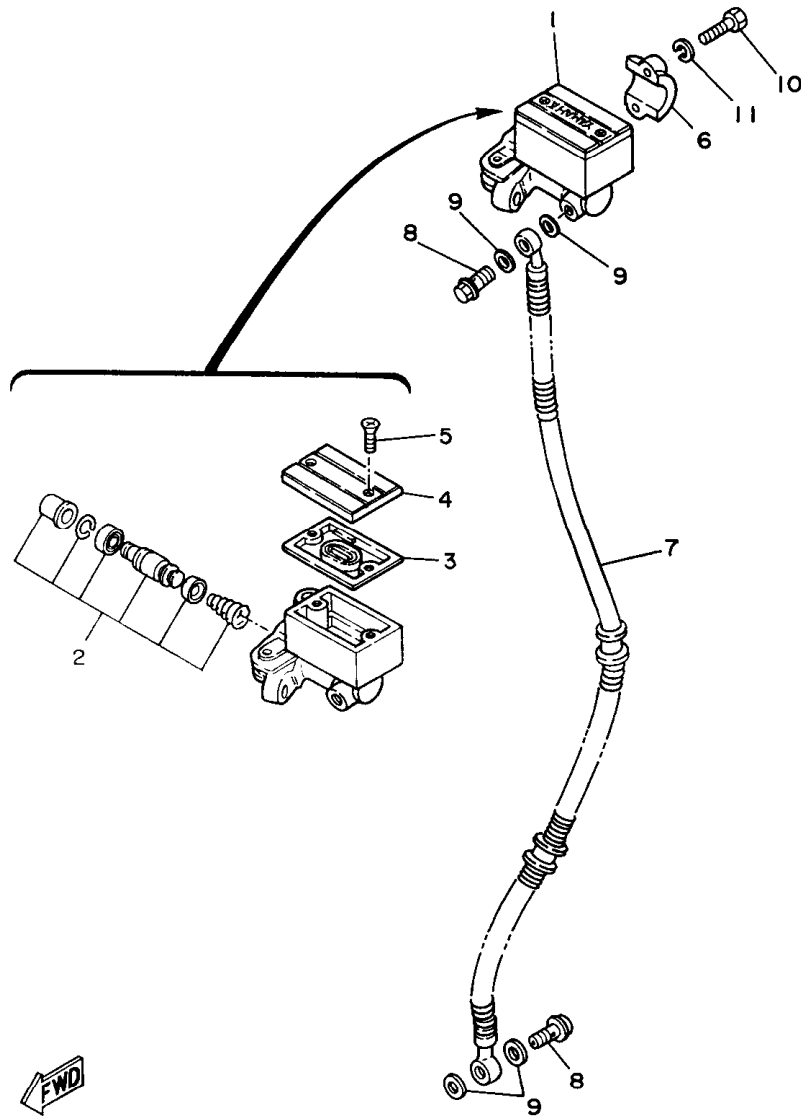

REF. NO.	PART NO.	DESCRIPTION	Q'TY	REMARKS
1	2RJ-25870-00	MASTER CYLINDER SUB ASSY	1	
2	23L-W0041-00	.CYLINDER KIT, master	1	
3	4L0-25854-00	.DIAPHRAGM, reservoir	1	
4	4H7-25852-00	.CAP, reservoir	1	
5	98706-04012	.SCREW, flat head	2	
6	4L0-25867-00	BRACKET, master cylinder	1	
7	3DM-25872-30	HOSE, brake 1	1	
8	90401-10159	BOLT, union	2	
9	90201-10118	WASHER, plate	4	
10	97007-06025	BOLT	2	
11	92907-06100	WASHER, spring	2	

3LS7351-5300



D11

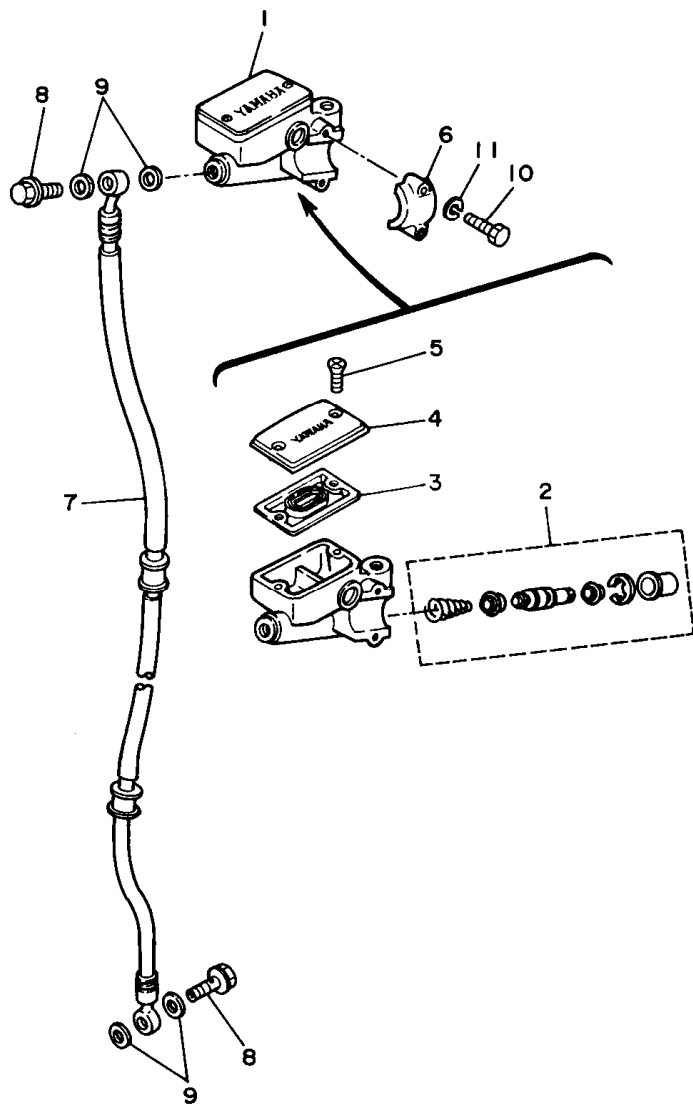

FIG. 32 FRONT MASTER CYLINDER (XV250S)

REF. NO.	PART NO.	DESCRIPTION	Q'TY	REMARKS
1	2UJ-25870-00	MASTER CYLINDER SUB ASSY	1	
2	23L-W0041-00	.CYLINDER KIT, master	1	
3	4L0-25854-00	.DIAPHRAGM, reservoir	1	
4	4H7-25852-00	.CAP, reservoir	1	
5	98707-04012	.SCREW, flat head	2	
6	4L0-25867-00	BRACKET, master cylinder	1	
7	3DN-25872-00	HOSE, brake 1	1	
8	90401-10159	BOLT, union	2	
9	90201-10118	WASHER, plate	4	
10	97007-06025	BOLT	2	
11	92907-06100	WASHER	2	



3LV7700-5320

**D12**

FIG. 33 STAND. FOOTREST

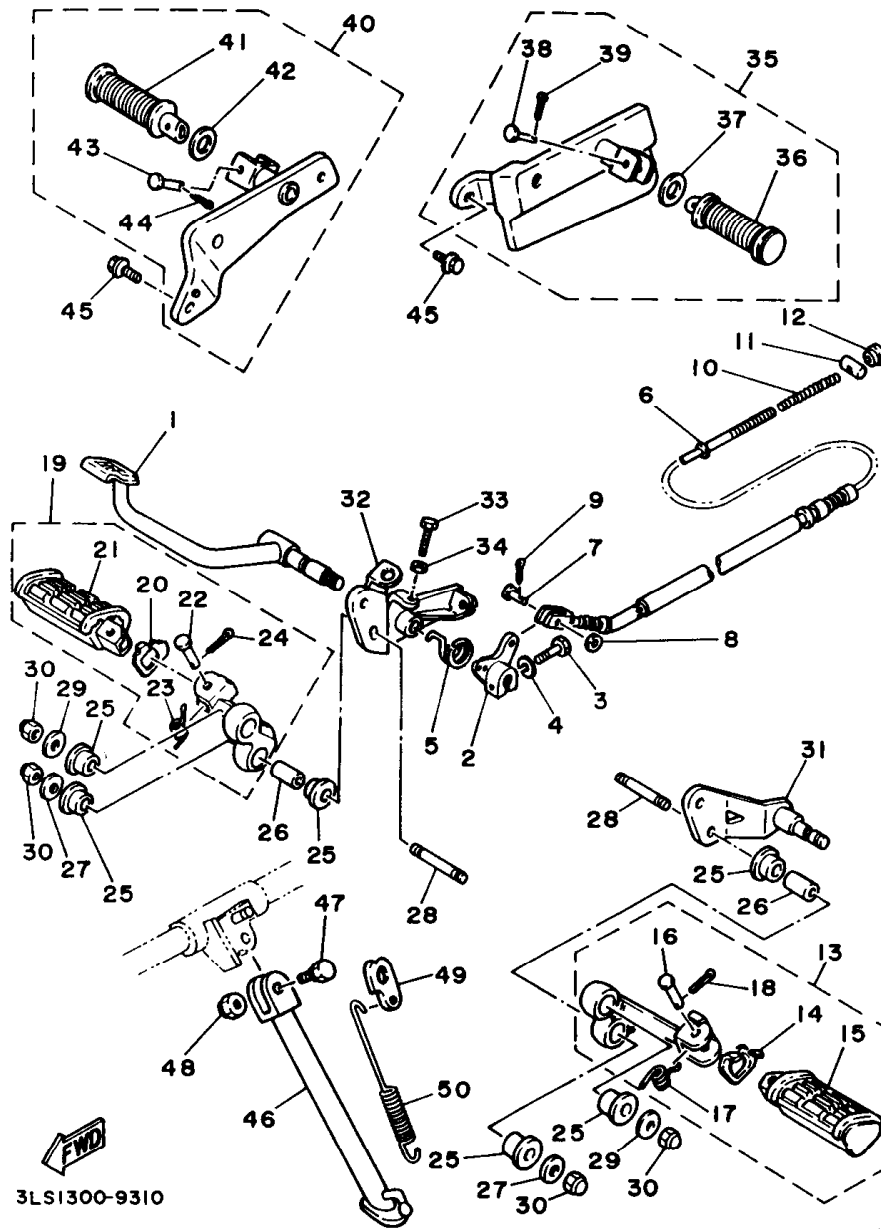

REF. NO.	PART NO.	DESCRIPTION	Q'TY	REMARKS
1	2UJ-27211-01	PEDAL, brake	1	
2	2UJ-27262-02	LEVER	1	
3	90109-06470	BOLT	1	
4	92907-06100	WASHER, spring	1	
5	2UJ-27216-00	SPRING, brake pedal	1	
6	2UJ-26351-00	CABLE, brake	1	
7	91701-06018	PIN, clevis	1	
8	92907-06200	WASHER, plain	1	
9	91401-20020	PIN, cotter	1	
10	90501-10245	SPRING, compression	1	
11	90249-12008	PIN	1	
12	90179-06411	NUT	1	
13	2UJ-27410-00	FRONT FOOTREST ASSY (LEFT)	1	
14	4X7-27417-00	.WASHER, footrest	1	
15	4X7-27413-00	.COVER, footrest	1	
16	91701-08038	.PIN, clevis	1	
17	90508-20023	.SPRING, torsion	1	
18	91401-25020	.PIN, cotter	1	
19	2UJ-27420-00	FRONT FOOTREST ASSY (RIGHT)	1	
20	4X7-27417-00	.WASHER, footrest	1	
21	4X7-27413-00	.COVER, footrest	1	
22	91701-08038	.PIN, clevis	1	
23	90508-20023	.SPRING, torsion	1	
24	91401-25020	.PIN, cotter	1	
25	2UJ-27414-00	DAMPER, footrest	8	
26	90387-100V6	COLLAR	4	
27	90201-100A1	WASHER, plate	2	
28	90116-10519	BOLT, stud	4	

**D13**

FIG. 33 STAND. FOOTREST

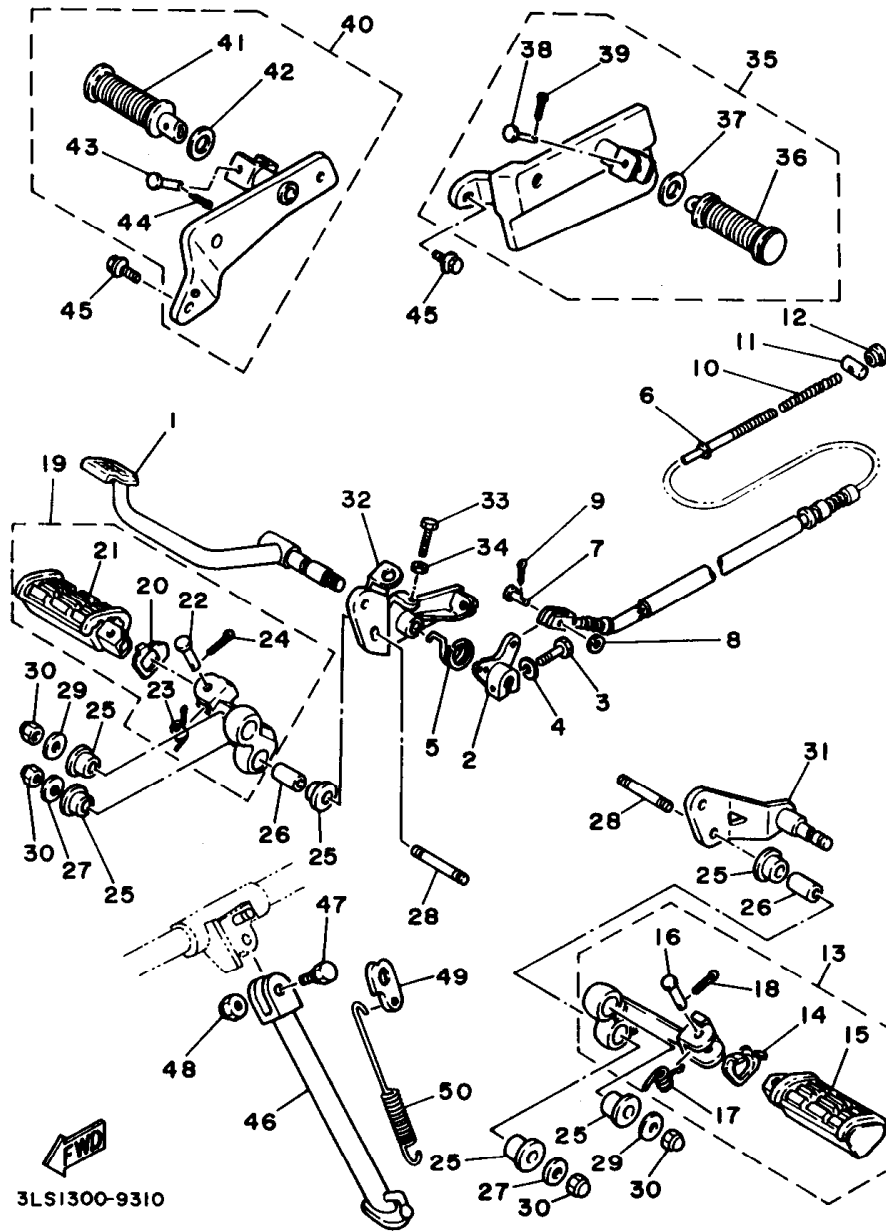

REF. NO.	PART NO.	DESCRIPTION	Q'TY	REMARKS
29	90201-10742	WASHER, plate	2	
30	95304-10800	NUT	4	
31	2UJ-2741L-00-33	BRACKET 4	1	YAMAHA BLACK
32	2UJ-2742L-00-33	BRACKET 5	1	YAMAHA BLACK
33	90153-06052	SCREW, hexagon	1	
34	95307-06600	NUT	1	
35	2UJ-27430-00-35	REAR FOOTREST ASSY 1	1	SILVER
36	120-27433-00	.COVER, rear footrest	1	
37	90201-20279	.WASHER, plate	1	
38	91701-06032	.PIN, clevis	1	
39	91401-20020	.PIN, cotter	1	
40	2UJ-27440-00-35	REAR FOOTREST ASSY 2	1	SILVER
41	120-27433-00	.COVER, rear footrest	1	
42	90201-20279	.WASHER, plate	1	
43	91701-06032	.PIN, clevis	1	
44	91401-20020	.PIN, cotter	1	
45	95024-08020	BOLT	2	
46	2UJ-27311-01	STAND, side	1	
47	90109-10474	BOLT	1	
48	90185-10037	NUT, self-locking	1	
49	2KT-27315-00	LINK, side stand	1	
50	2UJ-27316-00	SPRING, side stand	1	

D14

FIG. 34 GENERATOR

REF. NO.	PART NO.	DESCRIPTION	Q'TY	REMARKS
1	3DM-81410-00	STATOR ASSY	1	
2	3DM-81450-00	ROTOR ASSY	1	
3	98507-06030	SCREW, pan head	3	
4	92907-06100	WASHER, spring	3	
5	98507-05016	SCREW, pan head	2	
6	92907-05100	WASHER, spring	2	

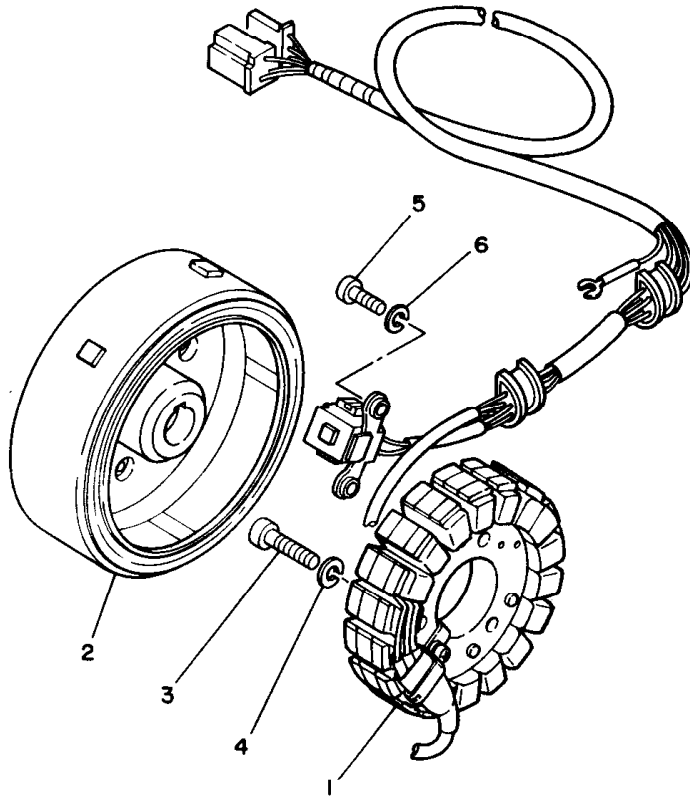

3DM010-8340

**D15**

FIG. 35 STARTING MOTOR

REF. NO.	PART NO.	DESCRIPTION	Q'TY	REMARKS
1	2UJ-81800-03	STARTING MOTOR ASSY	1	
2	50M-81801-M0	.BRUSH SET	1	
3	93210-55669	.O-RING	1	
4	93210-25711	.O-RING	1	
5	59V-81828-M0	.BOLT 2	2	
6	2UJ-8183G-00	.CORD COMP.	1	
7	91314-06020	BOLT	2	

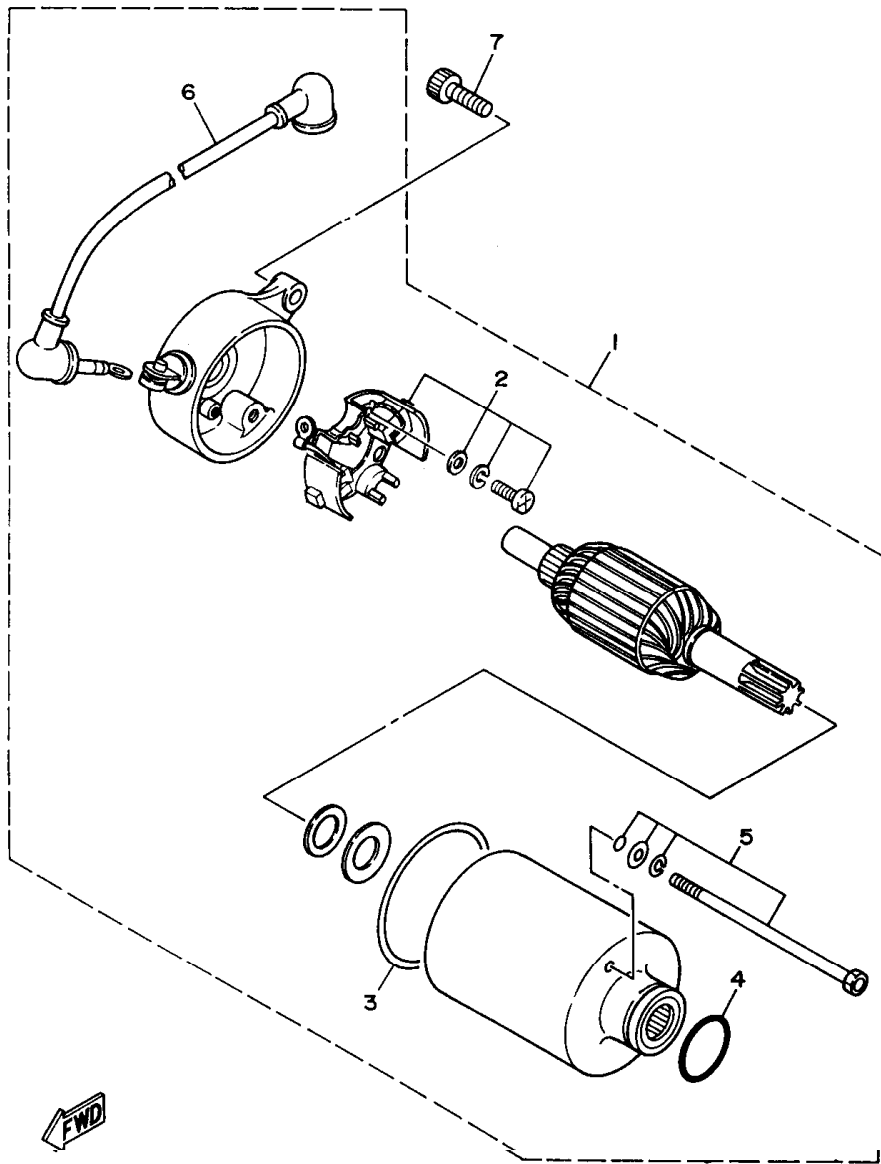

3LS7351-5330

**E2**



FIG. 36 FLASHER LIGHT

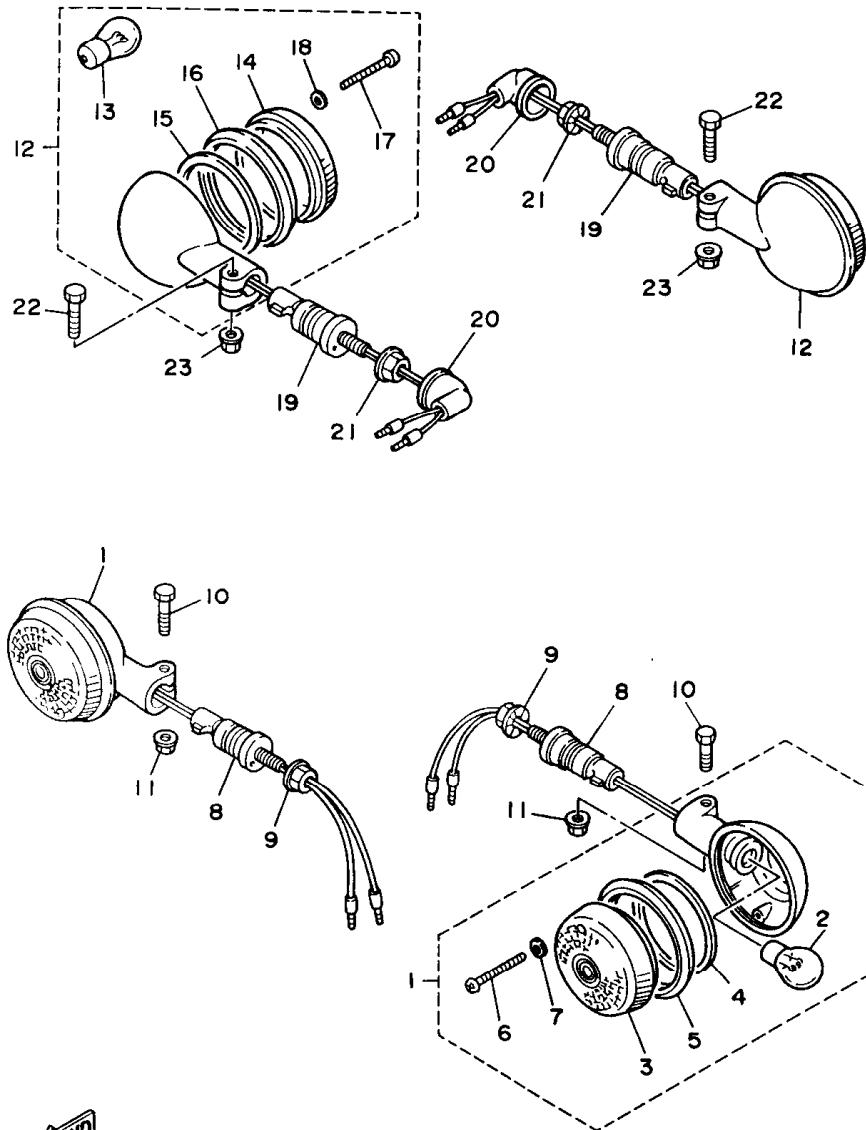

REF. NO.	PART NO.	DESCRIPTION	Q'TY	REMARKS
1	3LS-83310-00	FRONT FLASHER LIGHT ASSY 1	2	
2	1KT-83311-00	.BULB (12V-21W)	1	
3	42X-83312-00	.LENS, flasher	1	
4	42X-83313-00	.GASKET, flasher lens	1	
5	42X-83363-00	.LENS, rim	1	
6	341-83333-70	.SCREW, lens fitting	2	
7	42X-83359-00	.WASHER, special	2	
8	1AA-83318-00	STAY, flasher 1	2	
9	95304-12600	NUT	2	
10	97004-06030	BOLT	2	
11	95704-06500	NUT, flange	2	
12	3LS-83330-00	REAR FLASHER LIGHT ASSY 1	2	UR
	3LU-83330-00	REAR FLASHER LIGHT ASSY 1	2	UR FOR SWITZERLAND
13	1KT-83311-00	.BULB (12V-21W)	1	
14	2AE-83312-00	.LENS, flasher	1	
15	42X-83313-00	.GASKET, flasher lens	1	
16	42X-83363-00	.LENS, rim	1	
17	341-83333-70	.SCREW, lens fitting	2	
18	42X-83359-00	.WASHER, special	2	
19	1AA-83318-00	STAY, flasher 1	2	
20	18G-83365-00	CAP	2	
21	95304-12600	NUT	2	
22	97004-06030	BOLT	2	
23	95704-06500	NUT, flange	2	

  
3LS1332-9340

FIG. 37 METER

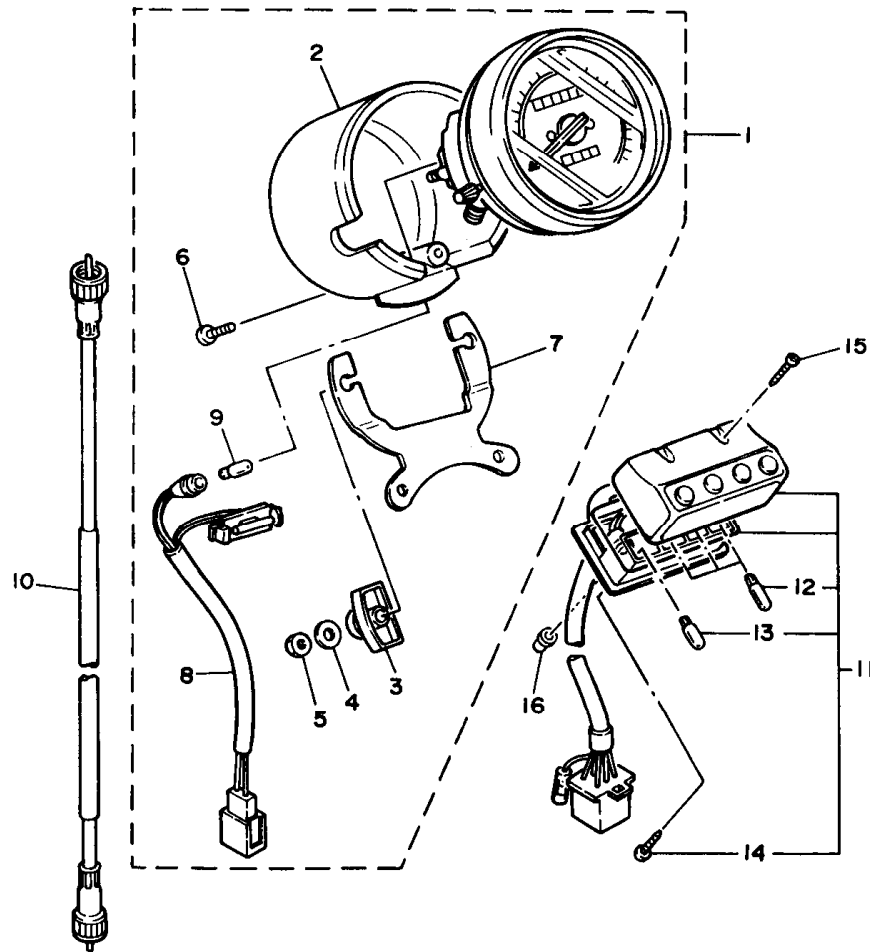

REF. NO.	PART NO.	DESCRIPTION	Q'TY	REMARKS
1	3DM-83570-01	SPEEDOMETER ASSY	1	UR
	3LS-83570-01	SPEEDOMETER ASSY	1	UR FOR ENGLAND
2	2UJ-83507-00	.COVER, speedometer	1	
3	1FG-83523-00	.DAMPER	2	
4	90201-05031	.WASHER, plate	2	
5	95303-05600	.NUT	2	
6	90164-04009	.SCREW, tapping	1	
7	2GV-83519-00	.BRACKET, meter	1	
8	2UJ-83509-00	.SOCKET CORD ASSY	1	
9	42X-83517-00	.BULB (12V-3W)	1	
10	34X-83550-01	SPEEDOMETER CABLE ASSY	1	
11	3BT-83530-10	PILOT LIGHT ASSY	1	
12	42X-83517-00	.BULB (12V-3W)	2	
13	2GV-83517-00	.BULB (12V-1.7W, T6.5)	1	
14	90164-03010	.SCREW, tapping	1	
15	98507-04035	SCREW, pan head	2	
16	90179-04579	NUT	2	



3DM010-8370

**E4**

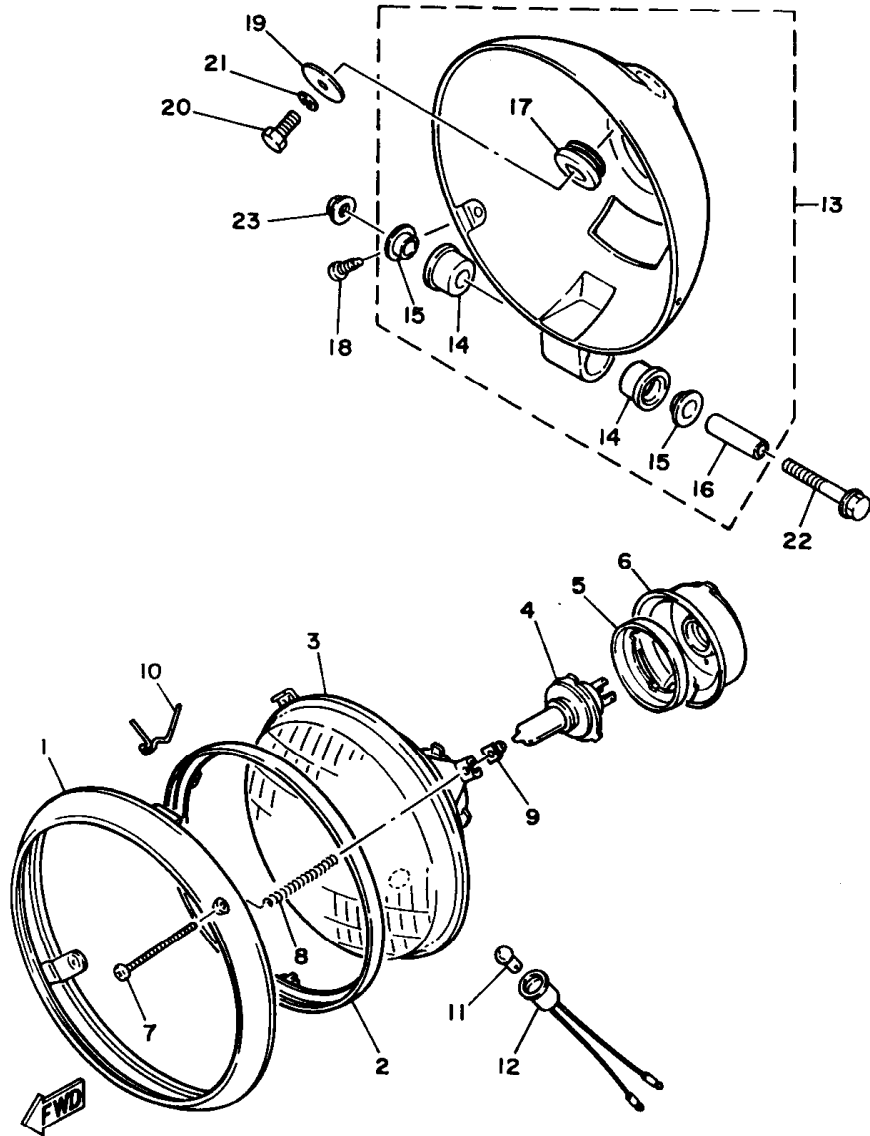

3DM010-8380

FIG. 38 HEADLIGHT

REF. NO.	PART NO.	DESCRIPTION	Q'TY	REMARKS
1	42X-84315-01	RIM, headlight	1	
2	5Y3-84395-00	RING, retaining	1	
3	2AE-84320-G0	LENS ASSY	1	UR
	55R-84321-H0	LENS ASSY	1	UR FOR ENGLAND
4	202 947514-013	BULB (12V-60/55W)	1	LM HALOGEN
5	2F9-84375-00	SETTING PLATE, bulb	1	
6	2F9-84397-01	COVER, socket	1	
7	90157-04001	SCREW, pan head	2	
8	1A0-84332-60	SPRING, screw	2	
9	198-84334-60	NUT, adjusting	2	
10	42X-84124-60	SPRING, set	1	
11	4E2-84347-00	BULB (12V-4W)	1	UR
	123-83516-21	BULB (12V-3.4W)	1	UR FOR ENGLAND
12	<del>34L-84346-00</del> 316 33	SOCKET, pilot light	1	
13	2UJ-84330-00	BODY ASSY	1	
14	42X-84345-00	.DAMPER, headlight	2	
15	1FK-84338-00	.COLLAR, body fitting	2	
16	2UJ-84338-00	.COLLAR, body fitting	1	
17	42X-84366-00	.DAMPER, headlight 1	1	
18	90157-05084	SCREW, pan head	2	
19	90201-06073	WASHER, plate	1	
20	97007-06016	BOLT	1	
21	92907-06100	WASHER, spring	1	
22	95824-06045	BOLT, flange	1	
23	95704-06500	NUT, flange	1	

**E5**

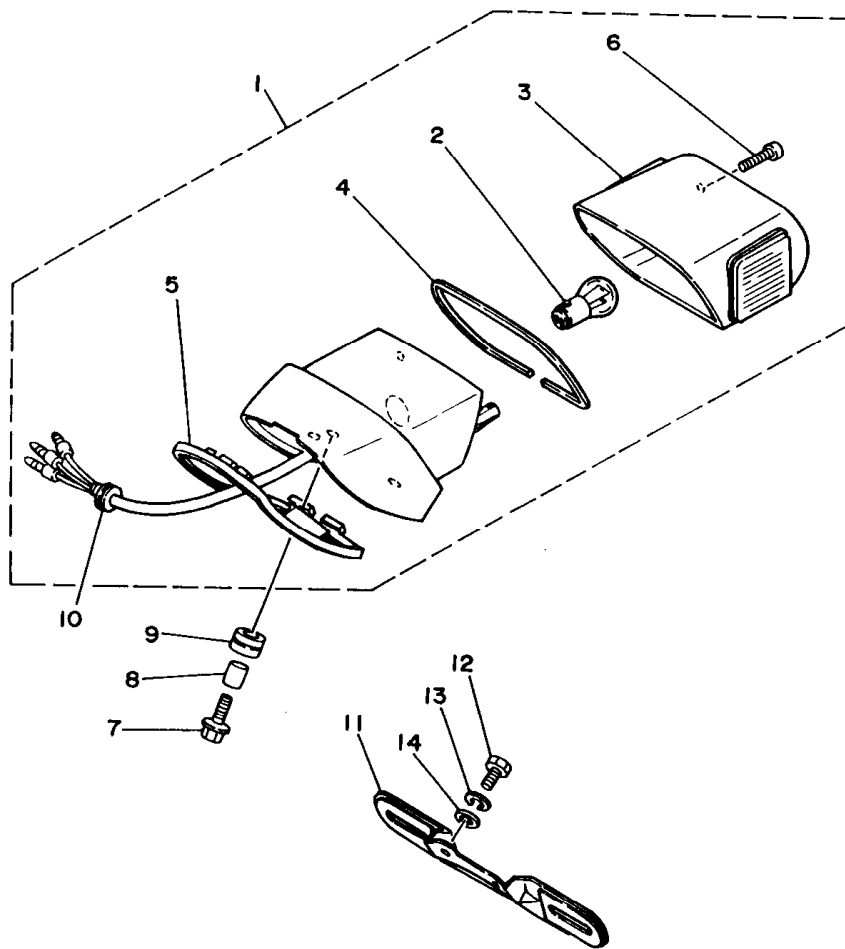

FIG. 39 TAILLIGHT

REF. NO.	PART NO.	DESCRIPTION	Q'TY	REMARKS
1	3LS-84700-00	TAILLIGHT ASSY	1	
2	31L-84714-00	.BULB, taillight (12V-21/5W)	1	
3	3LS-84721-00	.LENS, taillight	1	
4	2UJ-84723-00	.GASKET, tail lens	1	
5	2UJ-84704-00	.GASKET, taillight	1	
6	97707-40525	.SCREW, tapping	2	
7	90119-06182	BOLT, with washer	3	
8	90387-061V1	COLLAR	3	
9	90480-14229	GROMMET	3	
10	90480-16501	GROMMET	1	
11	3LS-84751-00	BRACKET, license	1	
12	97004-06014	BOLT	2	
13	92990-06100	WASHER, spring	2	
14	92901-06600	WASHER, plate	2	



3LS1332-9370

**E6**

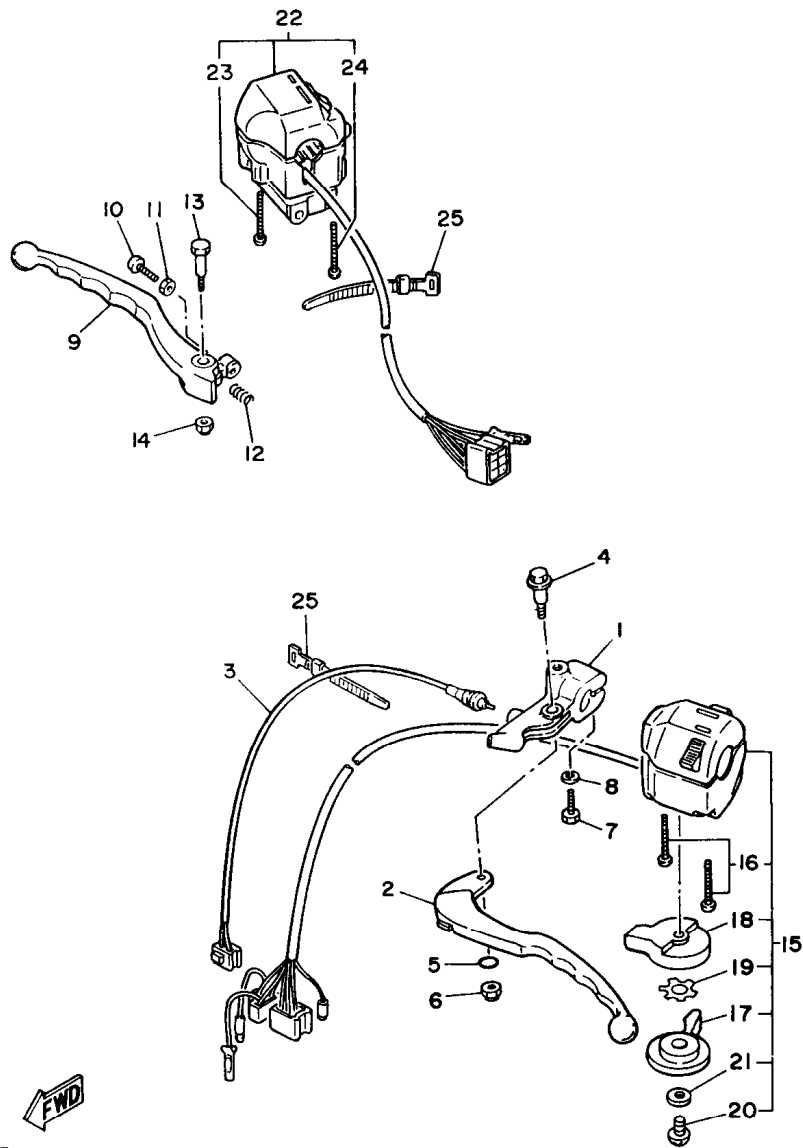

3L S1354-1380

FIG. 40 HANDLE SWITCH. LEVER

REF. NO.	PART NO.	DESCRIPTION	Q'TY	REMARKS
1	11U-82911-00	HOLDER, lever 1	1	
2	1AA-83912-00	LEVER 1	1	
3	2UJ-82917-00	SWITCH	1	
4	90109-06799	BOLT	1	
5	93210-11368	O-RING	1	
6	95607-06100	NUT, u	1	
7	97007-06025	BOLT	1	
8	92907-06100	WASHER, spring	1	
9	2W1-83922-00	LEVER 2	1	
10	90149-06153	SCREW	1	
11	90170-06010	NUT	1	
12	90501-10312	SPRING, compression	1	
13	90109-06577	BOLT	1	
14	95607-06100	NUT, u	1	
15	3DM-83972-00	SWITCH, handle 4	1	
16	98506-05035	.SCREW, pan head	2	
17	10M-83941-00	.LEVER, starter	1	
18	10M-83942-00	.COVER, starter	1	
19	90209-10131	.WASHER	1	
20	98506-06008	.SCREW, pan head	1	
21	92901-06200	.WASHER, plain	1	
22	3DM-83973-10	SWITCH, handle 3	1	
23	98506-05040	.SCREW, pan head	1	
24	98506-05045	.SCREW, pan head	1	
25	437-83936-01	BAND, switch cord	3	

E7

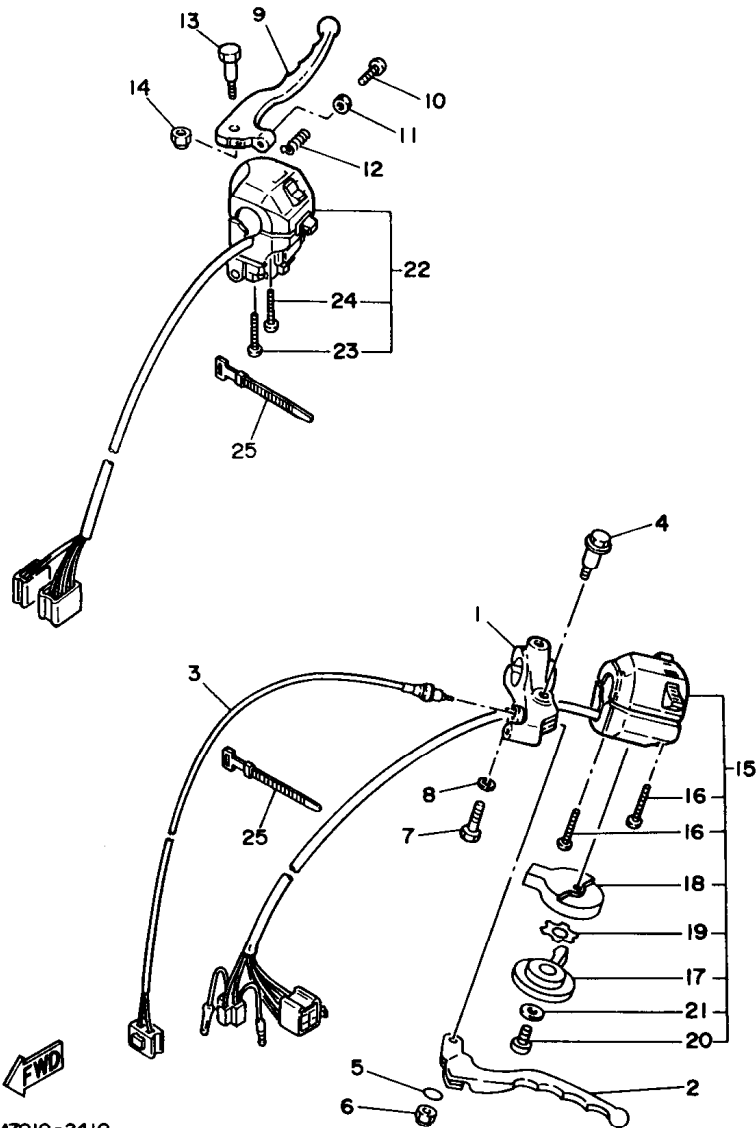

3DM7010-2410

FIG. 41 HANDLE SWITCH. LEVER (XV250S)

REF. NO.	PART NO.	DESCRIPTION	Q'TY	REMARKS
1	10M-82911-00	HOLDER, lever 1	1	
2	2GV-83912-00	LEVER 1	1	
3	2UJ-82917-00	SWITCH	1	
4	90109-06799	BOLT	1	
5	93210-11368	O-RING	1	
6	95607-06100	NUT, u	1	
7	97007-06025	BOLT	1	
8	92907-06100	WASHER, spring	1	
9	2W1-83922-00	LEVER 2	1	
10	90149-06131	SCREW	1	
11	90170-06010	NUT	1	
12	90501-10312	SPRING, compression	1	
13	90109-06577	BOLT	1	
14	95607-06100	NUT, u	1	
15	3DM-83972-10	SWITCH, handle 4	1	
16	98507-05035	.SCREW, pan head	2	
17	10M-83941-00	.LEVER, starter	1	
18	10M-83942-00	.COVER, starter	1	
19	90209-10131	.WASHER	1	
20	98506-06008	.SCREW, pan head	1	
21	92901-06200	.WASHER, plain	1	
22	3DM-83973-10	SWITCH, handle 3	1	
23	98506-05040	.SCREW, pan head	1	
24	98506-05045	.SCREW, pan head	1	
25	437-83936-01	BAND, switch cord	5	

E8

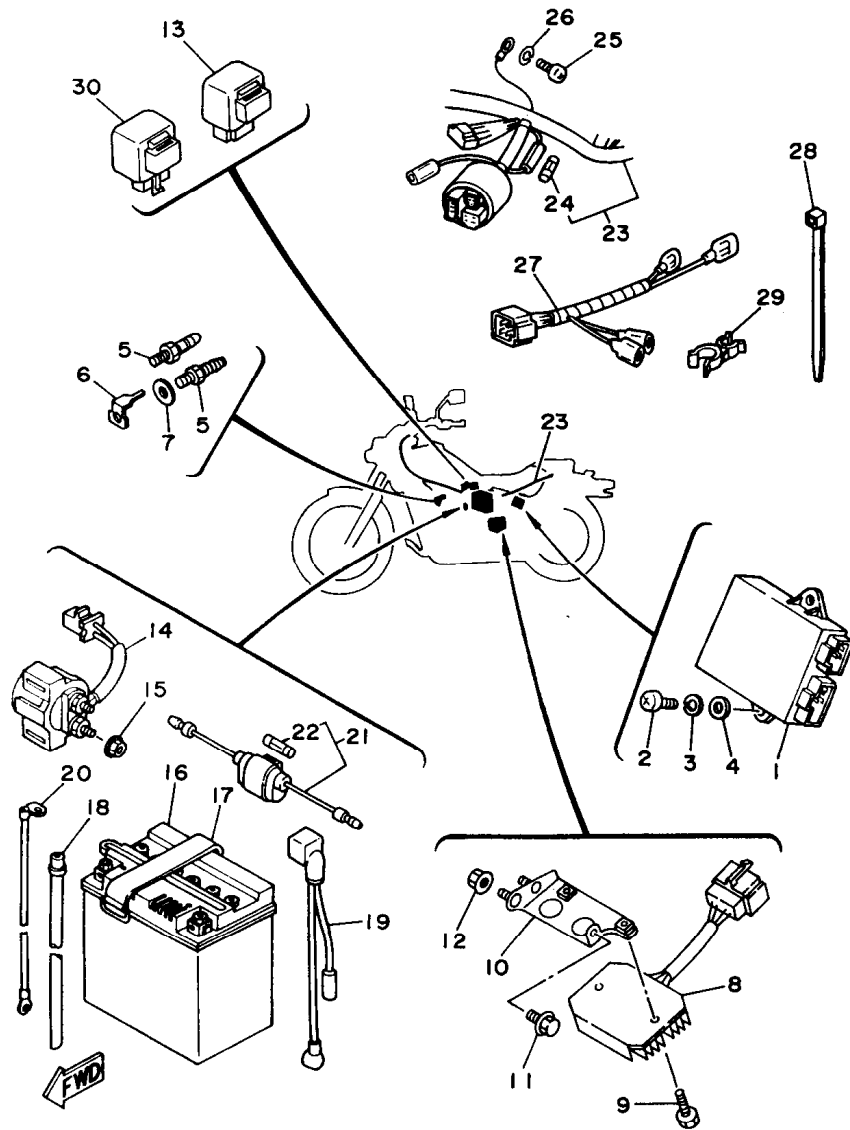

3LS735I-5390

FIG. 42 ELECTRICAL 1

REF. NO.	PART NO.	DESCRIPTION	Q'TY	REMARKS
1	3LS-82305-00	IGNITOR UNIT ASSY	1	
2	98507-06016	SCREW, pan head	1	
3	92907-06100	WASHER, spring	1	
4	92907-06600	WASHER, plate	1	
5	3BT-83790-00	HEATER ASSY	2	
6	3BT-82103-00	TERMINAL 1	1	
7	90201-085R5	WASHER, plate	2	
8	3LS-81960-00	RECTIFIER & REGULATOR ASSY	1	
9	90109-067E6	BOLT	2	
10	3DM-21287-00	BRACKET, regulator	1	
11	95807-06010	BOLT, flange	1	
12	95707-06500	NUT, flange	2	
13	2UJ-81950-00	RELAY ASSY	1	
14	36Y-81940-00	STARTER RELAY ASSY	1	
15	95707-06500	NUT, flange	2	
16	3DN-82110-00	BATTERY ASSY (G.S. GM10-3A-2)	1	
17	118-82131-00	BAND, battery	1	
18	90445-08248	HOSE	1	
19	2UJ-82115-00	WIRE, plus lead	1	
20	2UJ-82116-00	WIRE, minus lead	1	
21	2UJ-82150-01	FUSE HOLDER ASSY	1	
22	148-82151-00	.FUSE (20A)	1	
23	3LS-82590-20	WIRE HARNESS ASSY	1	
24	1E6-82151-00	.FUSE (10A)	2	
25	98507-06010	SCREW, pan head	1	
26	92907-06100	WASHER	1	
27	2UJ-82509-00	WIRE, sub lead	1	
28	12R-82591-00	BAND	2	

**E9**

FIG. 42 ELECTRICAL 1

REF. NO.	PART NO.	DESCRIPTION	Q'TY	REMARKS
29	90464-16119	CLAMP	1	
30	3GM-83350-00	FLASHER RELAY ASSY	1	

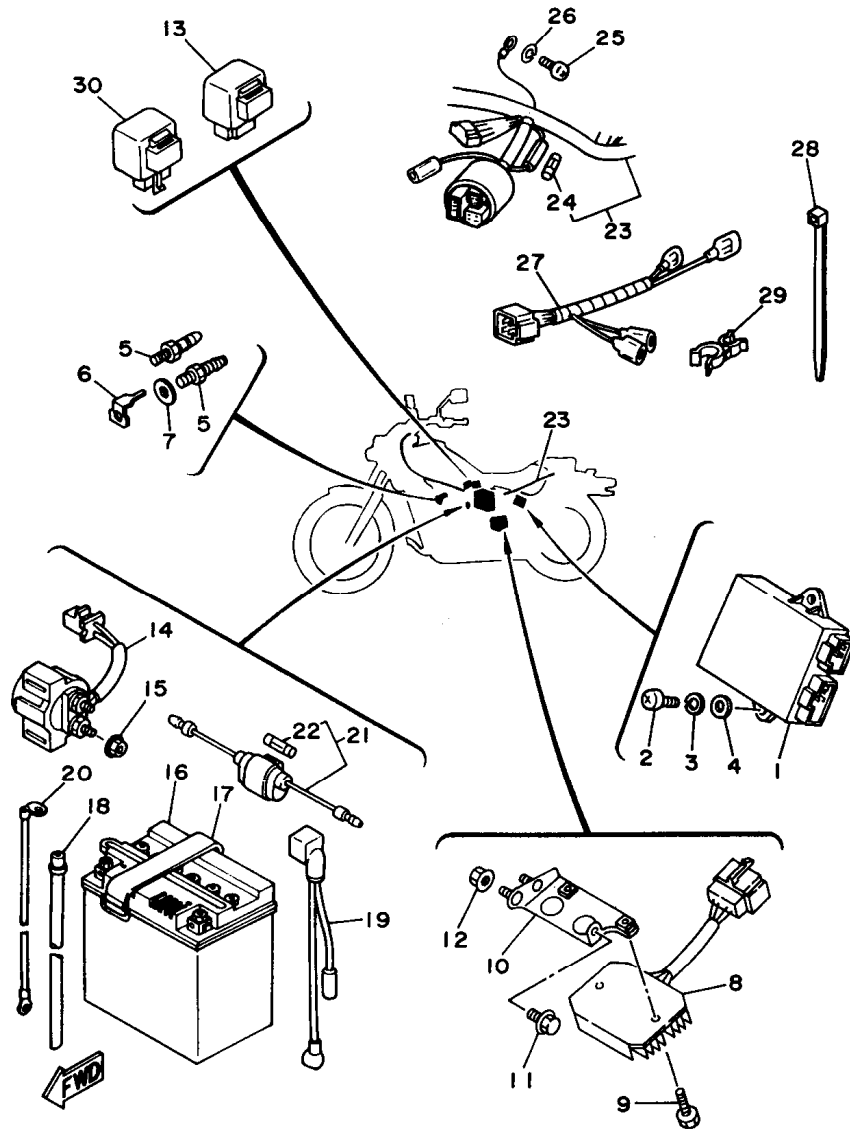

3LS735I-5390

**E10**



FIG. 43 ELECTRICAL 2

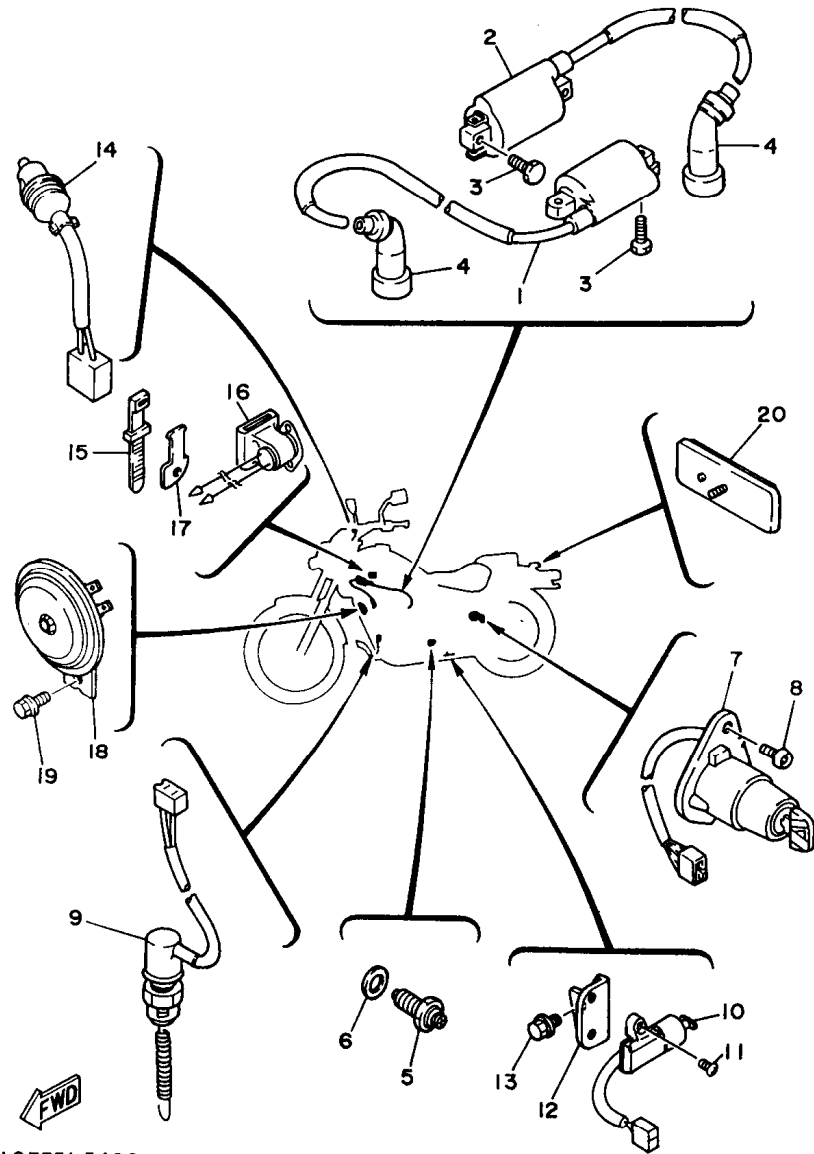

3LS7351-5400

REF. NO.	PART NO.	DESCRIPTION	Q'TY	REMARKS
1	2UJ-82310-00	IGNITION COIL ASSY	1	
2	2UJ-82320-00	IGNITION COIL ASSY	1	
3	97007-05020	BOLT	4	
4	1UY-82370-20	PLUG CAP ASSY	2	
5	2H7-82540-00	NEUTRAL SWITCH ASSY	1	
6	90430-10148	GASKET	1	
7	3DM-82510-00	MAIN SWITCH ASSY	1	
8	90149-06228	SCREW	2	
9	3XV-82530-01	STOP SWITCH ASSY	1	
10	3LD-82566-60	SWITCH, side stand	1	
11	90157-05079	SCREW	2	
12	2UJ-82565-00	PANEL, switch	1	
13	95807-06010	BOLT	1	
14	2UJ-83980-00	FRONT STOP SWITCH ASSY	1	
15	437-83936-11	BAND, switch cord	2	FOR XV250
16	3BT-82560-00	THERMO SWITCH ASSY	1	
17	3DM-82571-00	PANEL, switch	1	
18	3BN-83371-00	HORN	1	
19	95807-06010	BOLT, flange	1	
20	3Y6-85130-02	REAR REFLECTOR ASSY	1	

**E11**

**INDIVIDUAL SPEC.**

# **FOR SWITZERLAND**

The following pages provides a listing of only the parts that meet the specifications peculiar to your market. For those parts not appearing in these pages, refer to the "GENERAL SPEC" section.

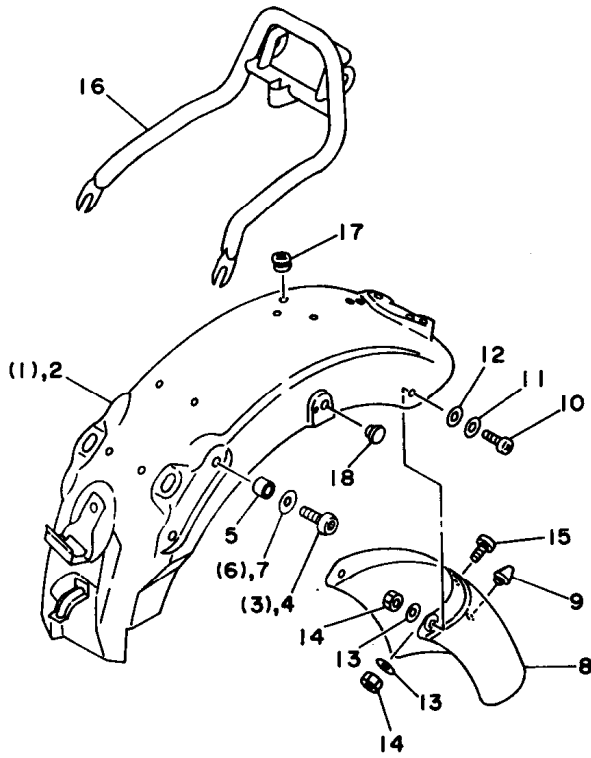

FIG. 44 ALTERNATE (FENDER)

REF. NO.	PART NO.	DESCRIPTION	Q'TY	REMARKS
1	2UJ-21610-00-PO	REAR FENDER COMP.	*	UR DARK REDDISH GRAY METALLIC 1
	2UJ-21610-00-6G	REAR FENDER COMP.	*	UR NEW YAMAHA BLACK
	2UJ-21610-00-MV	REAR FENDER COMP. (XV250S)	*	UR RED-E SPARKLE
2	3LS-21610-00-PO	REAR FENDER COMP.	1	UR DARK REDDISH GRAY METALLIC 1
	3LS-21610-00-6G	REAR FENDER COMP.	1	UR NEW YAMAHA BLACK
	3LS-21610-00-MV	REAR FENDER COMP. (XV250S)	1	UR RED-E SPARKLE
3	91317-10035	BOLT	*	
4	92014-10050	BOLT	2	
5	90387-100E2	COLLAR	2	
6	92907-10600	WASHER	*	
7	92903-10200	WASHER, plain	2	
8	3LS-21621-00	FLAP	1	
9	4G0-21639-00	DAMPER 2	1	
10	98507-06012	SCREW, pan head	2	
11	92907-06600	WASHER, plate	2	
12	90202-05193	WASHER, plate	2	
13	92907-06200	WASHER, plain	3	
14	95307-06600	NUT	3	
15	98904-06014	SCREW, bind	1	
16	3LU-21640-00	REAR STAY COMP.	1	
17	90480-12013	GROMMET	2	
18	1J3-24742-00	GROMMET	2	



3LS2300-2410

\* For convenience of reference:

Disregard the items asterisked (\*) in the "QTY" column. These are intended for GENERAL SPEC, and NOT for INDIVIDUAL SPEC.

**E13**

FIG. 45 ALTERNATE (SEAT)

REF. NO.	PART NO.	DESCRIPTION	Q'TY	REMARKS
1	2UJ-24750-00	TANDEM SEAT ASSY	* UR	
	3DM-24750-10	TANDEM SEAT ASSY (XV250S)	* UR	
2	3LS-24750-00	TANDEM SEAT ASSY	1 UR	
	3LS-24750-10	TANDEM SEAT ASSY (XV250S)	1 UR	
3	2UJ-24751-00	.COVER, tandem seat	1 UR	
	3DM-24751-10	.COVER, tandem seat (XV250S)	1 UR	
4	509-24724-00	.DAMPER, seat	4	
5	2UJ-2471A-00	.STAY, seat	1	
6	95707-06500	.NUT, flange	2	
7	95024-08012	BOLT, flange	*	
8	92014-08012	BOLT	1	
9	3DM-82571-00	PANEL, switch	*	
10	3BG-82571-00	PANEL, switch	1	

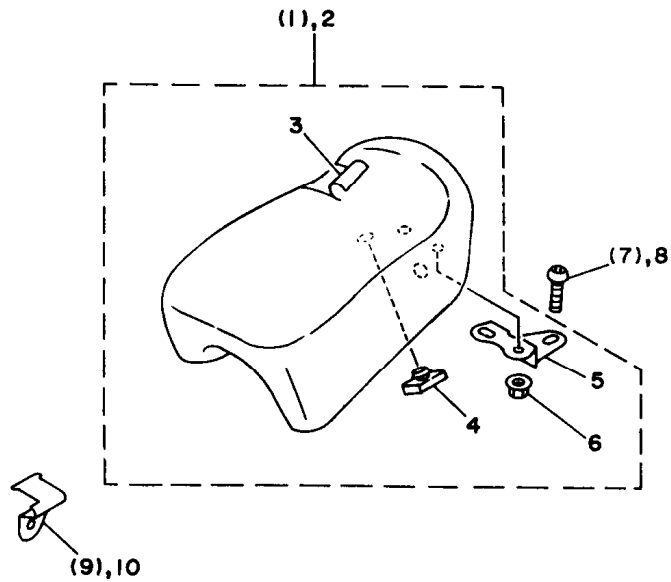

3LS2300-2420

\* For convenience of reference:

Disregard the items asterisked (\*) in the "QTY" column. These are intended for GENERAL SPEC, and NOT for INDIVIDUAL SPEC.

**E14**

**FOR SWEDEN**

**FOR PORTUGAL**

**FOR GREECE**

The following pages provides a listing of only the parts that meet the specifications peculiar to your market. For those parts not appearing in these pages, refer to the "GENERAL SPEC" section.

FIG. 46 ALTERNATE (FRONT FORK)

REF. NO.	PART NO.	DESCRIPTION	Q'TY	REMARKS
1	2A6-23408-00	STEERING LOCK ASSY	*	
2	*	STEERING LOCK ASSY	1 LM	
3	3DM-23484-00	CAP, handle lock	*	
4	134-23484-10	CAP, handle lock	1	
5	90502-09024	SPRING, conical	*	

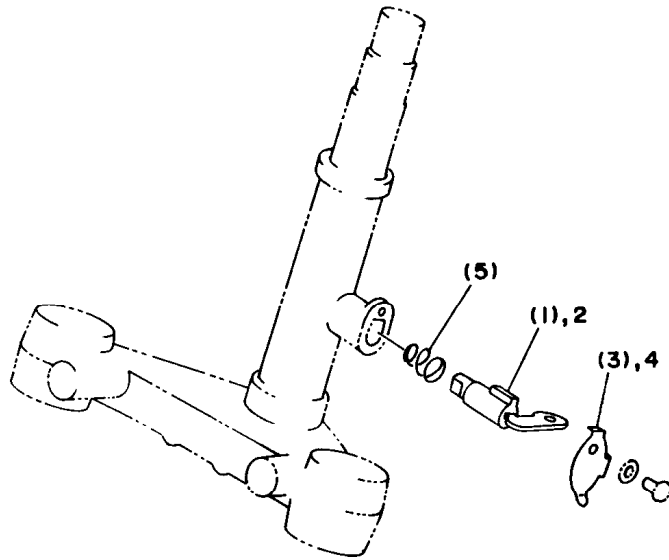

3LS2300-2430

\* For convenience of reference:

Disregard the items asterisked (\*) in the "QTY" column. These are intended for GENERAL SPEC, and NOT for INDIVIDUAL SPEC.

**F2**

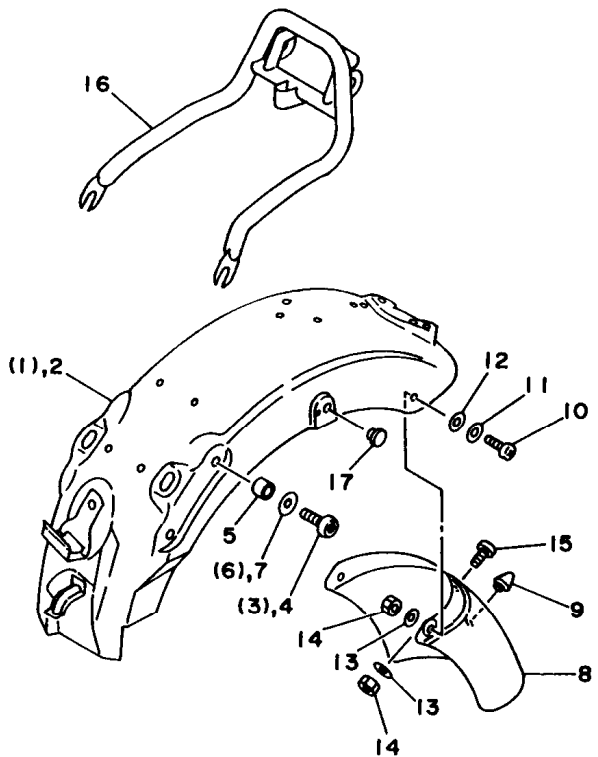

FIG. 47 ALTERNATE (FENDER)

REF. NO.	PART NO.	DESCRIPTION	Q'TY	REMARKS
1	2UJ-21610-00-P0	REAR FENDER COMP.	*	UR DARK REDDISH GRAY METALLIC 1
	2UJ-21610-00-6G	REAR FENDER COMP.	*	UR NEW YAMAHA BLACK
	2UJ-21610-00-MV	REAR FENDER COMP. (XV250S)	*	UR RED-E SPARKLE
2	3LS-21610-00-P0	REAR FENDER COMP.	1	UR DARK REDDISH GRAY METALLIC 1
	3LS-21610-00-6G	REAR FENDER COMP.	1	UR NEW YAMAHA BLACK
	3LS-21610-00-MV	REAR FENDER COMP. (XV250S)	1	UR RED-E SPARKLE
3	91317-10035	BOLT	*	
4	92014-10050	BOLT	2	
5	90387-100E2	COLLAR	2	
6	92907-10600	WASHER	*	
7	92903-10200	WASHER, plain	2	
8	3LS-21621-00	FLAP	1	
9	4G0-21639-00	DAMPER 2	1	
10	98507-06012	SCREW, pan head	2	
11	92907-06600	WASHER, plate	2	
12	90202-05193	WASHER, plate	2	
13	92907-06200	WASHER, plain	3	
14	95307-06600	NUT	3	
15	98904-06014	SCREW, bind	1	
16	3LS-21640-00	REAR STAY COMP.	1	
17	1J3-24742-00	GROMMET	2	



3LS2300-2440

\* For convenience of reference:

Disregard the items asterisked (\*) in the "QTY" column. These are intended for GENERAL SPEC, and NOT for INDIVIDUAL SPEC.

**F3**



FIG. 48 ALTERNATE (SEAT)

REF. NO.	PART NO.	DESCRIPTION	Q'TY	REMARKS
1	2UJ-24750-00	TANDEM SEAT ASSY	* UR	
	3DM-24750-10	TANDEM SEAT ASSY (XV250S)	* UR	
2	3LS-24750-00	TANDEM SEAT ASSY	1 UR	
	3LS-24750-10	TANDEM SEAT ASSY (XV250S)	1 UR	
3	2UJ-24751-00	.COVER, tandem seat	1 UR	
	3DM-24751-10	.COVER, tandem seat (XV250S)	1 UR	
4	509-24724-00	.DAMPER, seat	4	
5	2UJ-2471A-00	.STAY, seat	1	
6	95707-06500	.NUT, flange	2	
7	95024-08012	BOLT, flange	*	
8	92014-08012	BOLT	1	

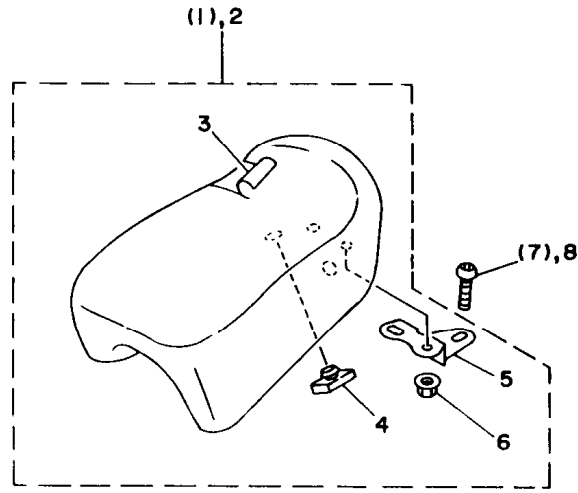

3LS2300-2450

\* For convenience of reference:  
 Disregard the items asterisked (\*) in the "QTY" column. These are intended for  
 GENERAL SPEC, and NOT for INDIVIDUAL SPEC.

**F4**

# **FOR SPAIN**

The following pages provides a listing of only the parts that meet the specifications peculiar to your market. For those parts not appearing in these pages, refer to the "GENERAL SPEC" section.

FIG. 49 ALTERNATE (FRONT FORK)

REF. NO.	PART NO.	DESCRIPTION	Q'TY	REMARKS
1	2A6-23408-00	STEERING LOCK ASSY	*	
2	*	STEERING LOCK ASSY	1 LM	
3	3DM-23484-00	CAP, handle lock	*	
4	134-23484-10	CAP, handle lock	1	
5	90502-09024	SPRING, conical	*	

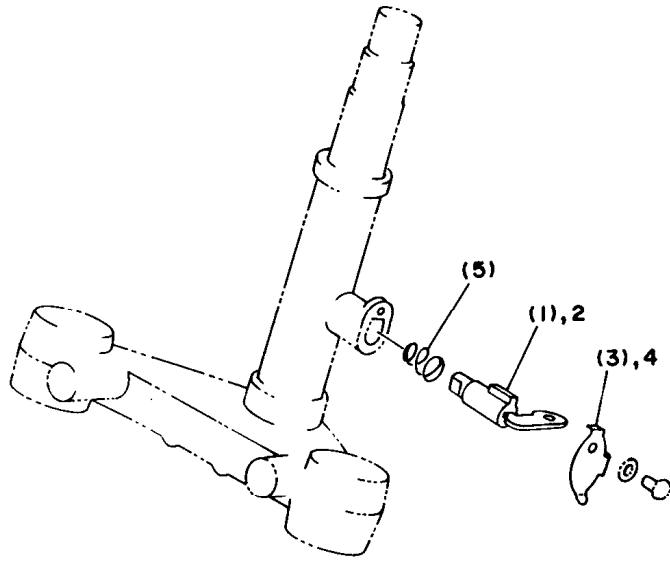

3LS2300-2430

\* For convenience of reference:

Disregard the items asterisked (\*) in the "QTY" column. These are intended for GENERAL SPEC, and NOT for INDIVIDUAL SPEC.

**F6**

**FOR DENMARK**

**FOR HOLLAND**

**FOR BELGIUM**

**FOR FINLAND**

The following pages provides a listing of only the parts that meet the specifications peculiar to your market. For those parts not appearing in these pages, refer to the "GENERAL SPEC" section.

FIG. 50 ALTERNATE (FENDER)

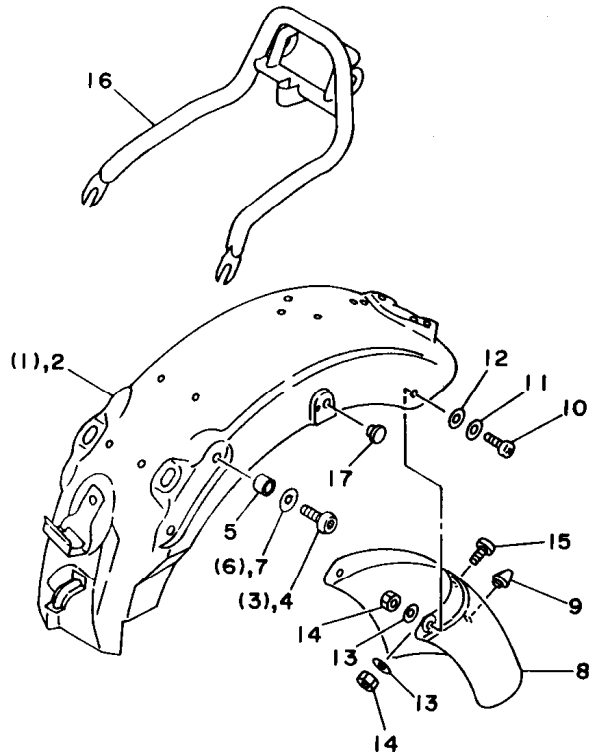

REF. NO.	PART NO.	DESCRIPTION	QTY	REMARKS
1	2UJ-21610-00-P0	REAR FENDER COMP.	*	UR DARK REDDISH GRAY METALLIC 1
	2UJ-21610-00-6G	REAR FENDER COMP.	*	UR NEW YAMAHA BLACK
	2UJ-21610-00-MV	REAR FENDER COMP. (XV250S)	*	UR RED-E SPARKLE
2	3LS-21610-00-P0	REAR FENDER COMP.	1	UR DARK REDDISH GRAY METALLIC 1
	3LS-21610-00-6G	REAR FENDER COMP.	1	UR NEW YAMAHA BLACK
	3LS-21610-00-MV	REAR FENDER COMP. (XV250S)	1	UR RED-E SPARKLE
3	91317-10035	BOLT	*	
4	92014-10050	BOLT	2	
5	90387-100E2	COLLAR	2	
6	92907-10600	WASHER	*	
7	92903-10200	WASHER, plain	2	
8	3LS-21621-00	FLAP	1	
9	4G0-21639-00	DAMPER 2	1	
10	98507-06012	SCREW, pan head	2	
11	92907-06600	WASHER, plate	2	
12	90202-05193	WASHER, plate	2	
13	92907-06200	WASHER, plain	3	
14	95307-06600	NUT	3	
15	98904-06014	SCREW, bind	1	
16	3LS-21640-00	REAR STAY COMP.	1	
17	1J3-24742-00	GROMMET	2	



3LS2300-2440

\* For convenience of reference:

Disregard the items asterisked (\*) in the "QTY" column. These are intended for GENERAL SPEC, and NOT for INDIVIDUAL SPEC.

**F8**

FIG. 51 ALTERNATE (FRONT FORK)

REF. NO.	PART NO.	DESCRIPTION	Q'TY	REMARKS
1	2A6-23408-00	STEERING LOCK ASSY	*	
2	*	STEERING LOCK ASSY	1 LM	
3	3DM-23484-00	CAP, handle lock	*	
4	134-23484-10	CAP, handle lock	1	
5	90502-09024	SPRING, conical	*	

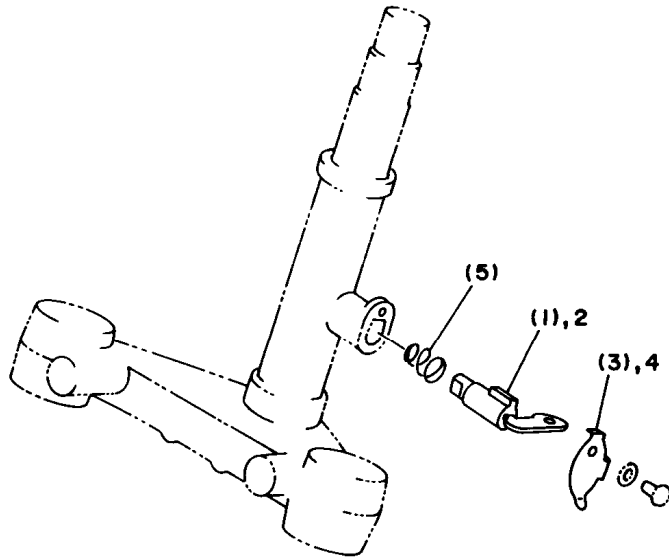

**FWD**  
3LS2300-2430

\* For convenience of reference:  
Disregard the items asterisked (\*) in the "Q'TY" column. These are intended for GENERAL SPEC, and NOT for INDIVIDUAL SPEC.

**F9**

FIG. 52 ALTERNATE (SEAT)

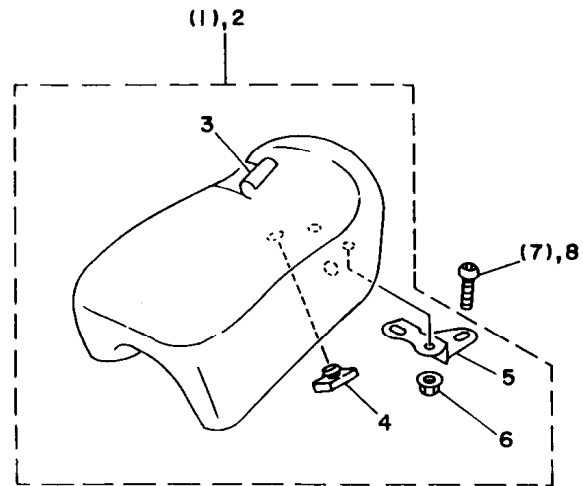

REF. NO.	PART NO.	DESCRIPTION	Q'TY	REMARKS
1	2UJ-24750-00	TANDEM SEAT ASSY	* UR	
	3DM-24750-10	TANDEM SEAT ASSY (XV250S)	* UR	
2	3LS-24750-00	TANDEM SEAT ASSY	1 UR	
	3LS-24750-10	TANDEM SEAT ASSY (XV250S)	1 UR	
3	2UJ-24751-00	.COVER, tandem seat	1 UR	
	3DM-24751-10	.COVER, tandem seat (XV250S)	1 UR	
4	509-24724-00	.DAMPER, seat	4	
5	2UJ-2471A-00	.STAY, seat	1	
6	95707-06500	.NUT, flange	2	
7	95024-08012	BOLT, flange	*	
8	92014-08012	BOLT	1	



3LS2300-2450

\* For convenience of reference:

Disregard the items asterisked (\*) in the "QTY" column. These are intended for GENERAL SPEC, and NOT for INDIVIDUAL SPEC.

**F10**

# **INDEX**

**(GENERAL SPEC.)**



NUMERICAL INDEX

PART NO.	GRID NO.	PART NO.	GRID NO.	PART NO.	GRID NO.	PART NO.	GRID NO.	PART NO.	GRID NO.	PART NO.	GRID NO.
23L-W0041-00	D-11	50M-12151-00	B- 5	2UJ-14469-00	B- 9	3DM-15461-00	B-15	4DN-18531-00	C- 6	2JN-23111-00	C-14
	D-12	22F-12156-00	B- 5	2UJ-14484-00	B-12	2UJ-15512-00	C- 2	4DN-18535-00	C- 6		C-15
4HM-W0045-00	D- 6	22F-12159-00	B- 5	2UJ-14485-00	B- 9	2UJ-15517-00	C- 2	4DN-18540-00	C- 6	3J2-23114-00	C-14
4FU-W0047-50	D- 6	2UJ-12171-00	B- 6	3DM-14504-01	B-10	5H0-15521-00	C- 2	136-18542-00	C- 6		C-15
51L-W0048-00	D- 6	2UJ-12176-00	B- 6	1FN-14565-00	B-10	51Y-15590-01	C- 2	2K9-18561-00	C- 6	58T-23118-L0	C-14
4FU-W0057-50	D- 6	2UJ-12181-00	B- 6	1HX-14565-00	B-10	3Y6-16111-03	C- 3	2UJ-21110-03-33	C- 8		C-15
2UJ-W1141-00	B- 4	2UJ-12210-01	B- 6	2GV-14603-00	B-12	2UJ-16150-00	C- 3	3LS-21110-02-33	C- 8	51Y-23125-00	C-14
2UJ-W2341-00-35	C-12	3DM-12213-00	B- 6	3DM-14613-00	B-12	30X-16154-00	C- 3	2UJ-21243-00	C- 8		C-14
3LS-W2536-00	D- 7	2UJ-12231-00	B- 6	2UJ-14621-00	B-12	31A-16321-00	C- 3	3DM-21287-00	E- 9	2UJ-23126-10	C-14
2UJ-11102-00	B- 2	2UJ-12241-00	B- 6	2UJ-14631-00	B-12	3J2-16324-00	C- 3	26H-21308-00	C- 8	2UJ-23136-10	C-14
3BG-11102-00	B- 2	2UJ-12279-00	B-14	2GV-14663-00	B-12	5Y1-16331-01	C- 3	2UJ-21315-00	C- 8	2UJ-23141-00	C-14
2UJ-1111F-00	B- 6	2UJ-13300-00	B- 7	3DM-14703-10	B-12	3YX-1635A-00	C- 3	2UJ-21318-01	C- 8		C-14
2UJ-11133-10	B- 2	3Y6-13326-01	B- 7	3LU-14703-00	B-12	30X-16351-01	C- 3	2UJ-21319-00	C- 8	51Y-23144-00	C-14
22F-11134-10	B- 2	2UJ-13341-00	B- 7	3BM-14714-00	B-13	4DN-16356-00	C- 3	2UJ-2135Y-00	C- 8		C-14
2UJ-11142-00	B- 2	51Y-13411-00	B- 7	3DM-14714-00	B-12	2UJ-16357-00	C- 4	2UJ-21510-00-MV	C- 9	51Y-23145-00	C-14
2UJ-11152-00	B- 2	2XK-13416-00	B- 7	42H-14808-00	B-13	1W1-16358-01	C- 3	2UJ-21510-00-PO	C- 9		C-14
15A-11162-00	B- 3	4X7-13440-90	B- 8	3BG-14840-00	B-12	30X-16371-00	C- 3	2UJ-21510-00-6G	C- 9	3DM-23149-10	C-14
2UJ-11166-00	B-14	3DM-13447-00	B- 8	42H-14857-00	B-13	2UJ-16380-00	C- 3	3WF-2153E-40	C-12		C-15
2UJ-11181-01	B- 2	3VD-13455-00	B-14	3BG-14858-00	B-13	3Y1-17121-01	C- 5	3DM-21597-00	C- 9	509-23151-L0	C-14
2UJ-11185-00	B- 2	3BG-13542-00	B-13	3BM-14867-00	B-13	3Y1-17131-01	C- 5	2UJ-21610-00-MV	C- 9		C-14
2UJ-11186-00	B- 2	1HX-13575-00	B- 9	3BG-14871-00	B- 2	3Y1-17141-00	C- 5	2UJ-21610-00-PO	C- 9	22W-23153-L0	C-14
22F-11186-00	B- 2	2UJ-13586-00	B- 9	3BG-14872-00	B- 2	3Y1-17151-00	C- 5	2UJ-21610-00-6G	C- 9		C-14
214-11198-01	B-14	3BG-13595-00	B- 9	3BG-14873-00	B-13	3Y1-17211-00	C- 5	2UJ-21641-00	C- 9	509-23158-L0	C-14
2UJ-11310-01	B- 3	3DM-13910-00	D- 3	3BG-14874-00	B-13	3Y1-17221-01	C- 5	2UJ-21670-00	C- 9		C-15
3BG-11310-00	B- 3	2UJ-13978-00	B- 9	1TA-14881-00	B-13	3Y1-17231-01	C- 5	2UJ-21711-00-MV	C-10	3DM-23164-00	C-12
2UJ-11320-01	B- 3	3DM-1410A-10	B-10	3BM-14882-00	B-12	3Y1-17241-00	C- 5	2UJ-21711-00-PO	C-10	2UJ-2317E-00	C-12
3BG-11320-00	B- 3	1HX-14103-00	B-10	3BM-14883-00	B-13	3Y1-17251-01	C- 5	2UJ-21711-00-6G	C-10	3DM-2317F-00	C-12
3DM-11351-00	B- 3	12R-14105-00	B-10	3BG-14884-00	B-13	3Y1-17402-00	C- 5	2N4-21717-00	C-10	2UJ-2317M-00	C-12
2UJ-11400-00	B- 4	3CF-14107-10	B-10	3BG-14885-00	B-13	4DN-17411-00	C- 5	2UJ-21721-00-MV	C-10	2UJ-23170-00	C-14
2UJ-11422-00	B- 4	2RJ-14118-00	B-10	3BG-1490J-00	B-10	3Y1-17456-00	C- 5	2UJ-21721-00-PO	C-10		C-14
2UJ-11478-00	B- 4	3DM-14141-30	B-11	3DM-1490J-00	B-10	3DM-17460-00	C- 5	2UJ-21721-00-6G	C-10	39K-23173-00	C-14
2UJ-1154A-00	B- 4	22F-14142-17	B-10	3DM-14900-10	B-10	2UJ-18101-01	C- 7	2UJ-2173M-01	C- 9		C-14
50M-11610-00	B- 4	1HX-14147-00	B-10	3LU-14900-10	B-10	2UJ-18110-00	C- 7	3DM-2173N-00	C- 9	2UJ-23174-00	C-12
50M-11610-20	B- 4	137-14153-00	B-10	1HX-14933-00	B-10	132-18113-01	C- 7	2UJ-21735-00	C- 9	278-23181-50	C-14
50M-11610-40	B- 4	353-14186-00	B-10	3BG-14940-00	B-11	2UJ-18115-02	C- 7	2UJ-2177G-00	C-10		C-15
2UJ-11631-00-A0	B- 4	12R-14191-00	B-10	1HX-14985-00	B-10	3Y1-18122-00	C- 6	3LS-22110-00-33	C-11	3LS-23340-00	C-15
22K-11633-01	B- 4	2LH-14197-00	B-11	22F-14991-00	B-10	4G0-18127-00	C- 7	55K-22129-00	C-11	2UJ-23346-00	C-15
2UJ-11636-00	B- 4	1AE-14227-00	B-10	256-14997-00	B-10	2UJ-18130-00	C- 7	2UJ-22141-01	C-11	2A6-23408-00	C-12
2UJ-11638-00	B- 4	1HX-14231-31	B-10	2UJ-15100-02	B-14	3Y1-18140-00	C- 7	55K-22151-01	C-11	156-23411-00	C-15
2UJ-11651-00	B- 4	620-14231-22-A0	B-10	2UJ-15138-00	B-14	3Y1-18141-00	C- 6	3DM-22210-00	C-11	183-23411-00	C-12
2UJ-11681-00	B- 4	1AE-14237-00	B-10	30X-15351-00	B- 7	2K7-18151-00	C- 6	447-22216-20	C-11	156-23412-00	C-12
50M-12111-00	B- 5	1AE-14261-00	B-10	3Y1-15361-00	B-15	2H9-18154-00	C- 7	447-22217-21	C-11	183-23412-00	C-12
2UJ-12114-00	B- 5	2UJ-14401-00	B- 9	1RG-15363-00	B-15		C- 7	1UJ-22243-00	C-11	4K0-23415-00	C-12
22F-12116-00	B- 5	2UJ-14419-00	B- 9	3DM-15411-01	B-15	3Y1-18161-00	C- 6	3LS-22311-00	C-11	5A8-23434-01	C-12
22F-12117-02	B- 5	2UJ-14422-00	B- 9	3DM-15421-00	B-15	3Y1-18185-01	C- 6	2UJ-23102-10	C-14	4H7-23441-00-38	C-12
22F-12118-01	B- 5	2UJ-14451-00	B- 9	3DM-15431-00	B-15	4DN-18511-00	C- 6	2UJ-23103-10	C-14	3DM-23442-00	C-12
22F-12119-01	B- 5	2UJ-14452-00	B- 9	2UJ-15441-00	B-15	4DN-18512-00	C- 6	2UJ-23110-00	C-14	42X-23442-00-38	C-12
50M-12121-01	B- 5	2UJ-14458-00	B- 9	3DM-15451-00	B-15	4DN-18513-00	C- 6		C-14	164-23462-00	C-15

NUMERICAL INDEX

PART NO.	GRID NO.	PART NO.	GRID NO.	PART NO.	GRID NO.	PART NO.	GRID NO.	PART NO.	GRID NO.	PART NO.	GRID NO.
3DM-23484-00	C-12	5Y1-25364-00	D- 7	2UJ-26335-01	D-10	1UY-82370-20	E-11	1AA-83912-00	E- 7	90109-067E6	E- 9
2UJ-24110-00-W1	D- 2	5Y1-25366-10	D- 7	3DM-26335-00	D- 9	2UJ-82509-00	E- 9	2GV-83912-00	E- 8	90109-06799	E- 7
2UJ-24110-00-X5	D- 2	2UJ-25371-00	D- 8	1E6-26342-00	D- 9	3DM-82510-00	E-11	2W1-83922-00	E- 7		E- 8
3DM-24110-00-08	D- 2	2UJ-25377-00	D- 7		D-10	3XV-82530-01	E-11		E- 8	90109-081F0	D- 6
3DM-24161-10	D- 2	10W-25381-00	D- 5	2UJ-26351-00	D-13	2H7-82540-00	E-11	437-83936-01	E- 7	90109-081G5	D- 8
3DM-24161-30	D- 3	2UJ-25381-00	D- 7	5H0-26393-00	D- 9	3B7-82560-00	E-11		E- 8	90109-081G6	D- 8
3LS-24161-30	D- 2	2UJ-25383-00	D- 7		D-10	2UJ-82565-00	E-11	437-83936-11	E-11	90109-10474	D-14
3DM-24162-30	D- 3	2UJ-25388-00	D- 8	2UJ-27211-01	D-13	3LD-82566-60	E-11	10M-83941-00	E- 7	90116-06228	B- 2
4H7-24181-00	D- 2	2UJ-2539F-00	D- 8	2UJ-27216-00	D-13	3DM-82571-00	E-11		E- 8	90116-10485	D- 7
2UJ-24182-00	D- 2	55K-2539F-00	D- 8	2UJ-27262-02	D-13	3LS-82590-20	E- 9	10M-83942-00	E- 7	90116-10519	D-13
42X-24183-00	D- 2	156-25398-00	D- 7	2UJ-27311-01	D-14	12R-82591-00	E- 9		E- 8	90119-05062	C-11
3DM-24240-70	D- 2	4DN-25445-20	D- 7	2KT-27315-00	D-14	10M-82911-00	E- 8	3DM-83972-00	E- 7	90119-06108	C-10
2UJ-24312-01	D- 3	4HM-2580T-00	D- 6	2UJ-27316-00	D-14	11U-82911-00	E- 7	3DM-83972-10	E- 8	90119-06182	E- 6
2UJ-24313-00	D- 3	3LP-2582T-00	D- 6	2UJ-2741L-00-33	D-14	2UJ-82917-00	E- 7	3DM-83973-10	E- 7	90123-08046	D- 9
2UJ-24491-01	D- 2	4H7-25852-00	D-11	2UJ-27410-00	D-13		E- 8		E- 8		D-10
2UJ-24500-00	D- 2		D-12	4X7-27413-00	D-13	3LS-83310-00	E- 3	2UJ-83980-00	E-11	90149-06011	D- 2
3H3-24523-00	D- 2	4L0-25854-00	D-11		D-13	1KT-83311-00	E- 3	42X-84124-60	E- 5	90149-06131	E- 8
1JK-24534-00	D- 2		D-12	2UJ-27414-00	D-13		E- 3	42X-84315-01	E- 5	90149-06153	E- 7
2UJ-24544-01	D- 2	4L0-25867-00	D-11	4X7-27417-00	D-13	2AE-83312-00	E- 3	2AE-84320-60	E- 5	90149-06154	C- 8
2UJ-24560-00	D- 2		D-12		D-13	42X-83312-00	E- 3	55R-84321-H0	E- 5	90149-06228	E-11
4X7-24602-04	D- 3	2RJ-25870-00	D-11	2UJ-2742L-00-33	D-14	42X-83313-00	E- 3	2UJ-84330-00	E- 5	90149-08067	C- 3
4X7-24612-00	D- 3	2UJ-25870-00	D-12	2UJ-27420-00	D-13		E- 3	1A0-84332-60	E- 5	90153-06029	B-14
2UJ-2471A-00	D- 4	3DM-25872-30	D-11	2UJ-27430-00-35	D-14	1AA-83318-00	E- 3	198-84334-60	E- 5	90153-06042	B-15
2UJ-24710-00	D- 4	3DN-25872-00	D-12	120-27433-00	D-14		E- 3	1FK-84338-00	E- 5	90153-06052	D-14
3DM-24710-10	D- 4	3DM-25886-10	C-15		D-14	3LS-83330-00	E- 3	2UJ-84338-00	E- 5	90157-04001	E- 5
1WG-24712-00	D- 4	4BP-25919-00	D- 6	2UJ-27440-00-35	D-14	3LU-83330-00	E- 3	42X-84345-00	E- 5	90157-05079	E-11
18A-24724-00	D- 4	3YX-25929-00	D- 6	2UJ-28100-00	C- 8	341-83333-70	E- 3	34L-84346-00	E- 5	90157-05084	E- 5
509-24724-00	D- 4	3YX-25937-00	D- 6	3DM-81410-00	D-15		E- 3	4E2-84347-00	E- 5	90159-06016	C- 3
2UJ-24731-00	D- 4	5R2-25937-00	D- 6	3DM-81450-00	D-15	3GM-83350-00	E-10	42X-84366-00	E- 5	90163-04003	B-12
3DM-24731-10	D- 4	2NT-26111-00	D- 9	2UJ-81800-03	E- 2	42X-83359-00	E- 3	2F9-84375-00	E- 5	90164-03010	E- 4
47X-24739-00	D- 4	2UJ-26111-01	D-10	50M-81801-M0	E- 2		E- 3	5Y3-84395-00	E- 5	90164-04009	E- 4
2UJ-2475H-00	D- 4	1FW-2622F-01	D-10	59V-81828-M0	E- 2	42X-83363-00	E- 3	2F9-84397-01	E- 5	90170-05302	B- 5
2UJ-24750-00	D- 4	1FK-26240-00	D- 9	2UJ-8183G-00	E- 2		E- 3	3LS-84700-00	E- 6	90170-06010	E- 7
3DM-24750-10	D- 4	2UJ-26240-00	D-10	36Y-81940-00	E- 9	18G-83365-00	E- 3	2UJ-84704-00	E- 6		E- 8
	D- 4	21A-26241-00	D-10	2UJ-81950-00	E- 9	3BN-83371-00	E-11	31L-84714-00	E- 6	90170-06228	C- 7
2UJ-24751-00	D- 4	42X-26241-00	D- 9	3LS-81960-00	E- 9	2UJ-83507-00	E- 4	3LS-84721-00	E- 6	90170-16311	C- 3
2UJ-24754-00	D- 4	42N-26246-00	D-10	3BT-82103-00	E- 9	2UJ-83509-00	E- 4	2UJ-84723-00	E- 6	90170-16326	C- 3
3DM-25104-00	D- 5	26H-2628J-00	D- 9	3DN-82110-00	E- 9	123-83516-21	E- 5	3LS-84751-00	E- 6	90171-14056	D- 8
4DN-25111-20-35	D- 5	1J7-26290-F0	D- 9	2UJ-82115-00	E- 9	2GV-83517-00	E- 4	3Y6-85130-02	E-11	90173-06015	D- 4
322-25118-00	D- 5		D-10	2UJ-82116-00	E- 9	42X-83517-00	E- 4	90101-06576	B-12	90175-05005	B- 9
4DN-25190-01	D- 5	1J7-26290-G0	D- 9	118-82131-00	E- 9		E- 4	90101-06765	D- 7	90179-04579	E- 4
2UJ-25304-00	D- 7		D-10	26H-82131-00	C-10	2GV-83519-00	E- 4	90101-08590	B- 6	90179-06403	D-10
2UJ-25311-10	D- 7	2UJ-26311-01	D-10	2UJ-82150-01	E- 9	1FG-83523-00	E- 4	90105-08324	B- 2	90179-06411	D-13
2UJ-25317-00	D- 7	3DM-26311-01	D- 9	1E6-82151-00	E- 9	3BT-83530-10	E- 4	90105-10638	D- 6	90179-06500	B-12
2RH-25321-10	D- 7	2UJ-26312-01	D-10	148-82151-00	E- 9	34X-83550-01	E- 4	90105-14102	C-12	90179-08148	D- 9
3Y6-2533A-01	D- 7	3DM-26312-01	D- 9	3LS-82305-00	E- 9	3DM-83570-01	E- 4	90109-06470	D-13		D-10
2RH-25351-00	D- 7	2UJ-26331-01	D-10	2UJ-82310-00	E-11	3LS-83570-01	E- 4	90109-06577	E- 7	90179-08656	C- 8
5H0-25355-00	D- 7	3DM-26331-00	D- 9	2UJ-82320-00	E-11	3BT-83790-00	E- 9		E- 8	90179-12248	B- 4

NUMERICAL INDEX

PART NO.	GRID NO.	PART NO.	GRID NO.	PART NO.	GRID NO.	PART NO.	GRID NO.	PART NO.	GRID NO.	PART NO.	GRID NO.
90179-25033	C-12	90340-32088	B-15	90501-26148	C- 3	92907-06100	D-13	93306-20541	C- 5	95304-08700	D- 8
90183-04027	B-12	90380-12121	C-11	90502-09024	C-13		D-15	93306-30416	D- 7	95304-10800	D-14
90185-10037	D-14	90381-22070	B- 6	90506-15260	D- 7		E- 5	93306-30525	C- 5	95304-12600	E- 3
90185-12164	C-11	90385-10026	B-12	90508-12430	C- 6		E- 7	93306-30615	B- 4		E- 3
90201-05031	E- 4	90386-18163	C-11	90508-14433	C- 3		E- 8	93315-23612	C- 6	95307-05600	B-13
90201-05036	B- 9	90387-061V1	E- 6	90508-20023	D-13		E- 9	93315-31428	C- 3	95307-05800	C- 9
90201-06073	E- 5	90387-066M3	B- 2		D-13		E- 9	93410-22039	C- 5	95307-06600	C- 3
90201-065F3	C-11	90387-07391	B-12	90508-26434	C- 7	92907-06200	C- 3	93410-25010	C- 5		D-14
90201-06697	B- 2	90387-100V6	D-13	90508-32374	C- 7		D-13	93420-28055	C- 3	95604-10200	D- 7
90201-080L7	B- 2	90387-12787	C- 7	90560-15240	D- 5	92907-06600	B- 6	93440-10109	B- 2	95607-06100	E- 7
90201-08087	C- 3	90387-153U1	D- 8	91311-08035	C-15		B- 9	93440-25084	C- 5		E- 7
90201-08326	B- 6	90387-15600	D- 5	91314-06016	B- 6		B- 9	93440-34025	C- 6		E- 8
90201-085R5	E- 9	90401-10159	D-11	91314-06020	E- 2		B-12	93450-14088	B- 4		E- 8
90201-08569	D- 2		D-12	91314-06075	D-10		B-14	93501-04011	C-12	95617-10100	C-12
90201-087G2	C-11	90413-07007	B- 9	91314-08025	C-12		D- 2	93511-32027	C- 4	95704-06500	E- 3
90201-100A1	D-13	90430-06014	B-14	91317-05010	D- 3		E- 9	93603-12030	B- 7		E- 3
90201-10118	D-11	90430-10148	E-11	91317-06012	B- 6	92907-08100	D- 2	93604-18100	C- 6		E- 5
	D-12	90445-08248	E- 9	91317-06016	C-12	92907-10600	C- 9	93604-29151	C- 6	95707-06500	D- 4
90201-10119	B- 7	90445-11501	D- 2	91317-06020	B- 9	92990-06100	E- 6	94113-154W1	D- 7		E- 9
90201-105A2	C-12	90445-117F0	B- 9	91317-06025	B- 9	92990-08100	D- 8	94130-185T4	D- 5		E- 9
90201-10742	D-14	90445-11754	D- 3	91317-06040	B- 2	92990-08600	D- 8	94213-15265	D- 7	95707-10500	C- 9
90201-12191	B- 4	90445-11763	B- 9	91317-06110	B- 2	93101-14089	B-15	94227-18195	D- 5	95807-06010	B-12
90201-124E4	C- 7	90460-54111	B- 9	91317-08018	C- 2	93101-17093	C- 5	94313-15154	D- 7		E- 9
90201-124E4	C- 7	90460-54137	B- 9	91317-10035	C- 9	93102-12106	C- 7	94345-18081	D- 5		E-11
90201-17255	C- 7	90461-06087	B-11	91401-20020	D- 8	93102-14209	C- 3	94416-18523	D- 5		E-11
90201-20276	C- 5	90464-16119	E-10		D-13	93102-20281	D- 5	94427-15476	D- 7	95807-06016	D- 4
90201-20279	D-14	90465-06322	B-15		D-14	93102-25208	C- 5	94580-25110	B- 6	95807-06020	B-12
	D-14	90465-08158	B-14		D-14	93106-30029	D- 7	94581-18114	D- 7	95807-06025	B-12
90201-22793	C- 5	90465-08277	B-14	91401-25020	D-13	93109-18020	C-11	94701-00282	B- 2		B-12
90201-25291	C- 2	90465-08092	B-13		D-13	93210-06245	B- 7	94701-00283	B- 2	95807-08012	B-12
90201-253K0	C- 5	90467-08092	B-13		D- 8	93210-10096	B- 7	95024-06010	D- 2	95807-10014	B-12
90202-05057	B-13	90467-10008	B- 9	91401-30030	D-13	93210-11368	E- 7		D- 2	95814-08110	C- 8
90202-05193	D- 2		D- 3	91701-06018	D-14		E- 8		D- 2	95814-08150	C- 8
90208-04029	C-13		D- 3	91701-06032	D-14	93210-14369	B-15	95024-06012	C-12	95817-08016	C- 8
90209-06223	C-11	90467-11106	B- 9		D-14	93210-19123	B-15	95024-06016	C-12	95817-08035	B-12
90209-10131	E- 7	90467-14015	B-14	91701-08038	D-13	93210-25711	E- 2	95024-06020	B- 2	95817-10020	C- 9
	E- 8	90467-26111	B-12		E- 7	93210-30611	B- 9	95024-08012	C- 9	95824-06045	E- 5
90209-22191	C- 5	90468-08104	B-13	92901-06200	E- 8	93210-32172	B-15		C-11	97004-06014	E- 6
90209-31300	B- 4	90468-10050	D- 4		E- 8	93210-35389	B- 7		D- 4	97004-06030	E- 3
90215-16156	C- 3	90480-01502	C- 9	92901-06600	E- 6	93210-44704	B- 2	95024-08020	D-14		E- 3
90215-16222	C- 3	90480-13018	B- 2	92903-12200	C-11	93210-53679	B- 2	95024-08040	C-12	97007-05020	E-11
90215-16320	C- 3	90480-13428	C-10	92903-14200	D- 8	93210-55669	B- 3	95027-06012	D- 4	97007-06016	E- 5
90249-12008	D-13	90480-14229	E- 6	92907-05100	C- 9	93210-64297	E- 2		D- 9	97007-06025	D-11
90269-04003	C-13	90480-16501	E- 6		D-15	93210-78544	B- 8		D-10		D-12
90280-16053	B- 4	90480-22362	C-10	92907-05200	B-13	93306-00302	B- 2		C- 5	95303-05600	E- 7
90282-07023	C- 3	90501-10245	D-13	92907-05600	C- 9	93306-00426	C- 5		E- 4	95304-06600	E- 8
90338-08163	C-12	90501-10312	E- 7	92907-06100	D- 2	93306-20209	C- 5		D- 7	95304-06700	D- 2
90338-10132	B-12		E- 8		D-11	93306-20226	D- 5		C- 7	97007-08035	D- 2
90340-14068	B-15	90501-18576	B- 7		D-12		D- 7	95304-08600	D- 8	97024-06020	C- 7

NUMERICAL INDEX

PART NO.	GRID NO.	PART NO.	GRID NO.	PART NO.	GRID NO.	PART NO.	GRID NO.	PART NO.	GRID NO.
97027-06010	C- 5	98511-04012	B-10						
97027-06012	B- 6	98706-04012	D-11						
	B-14	98707-04012	D-12						
97704-40012	B-12	98707-05035	C- 6						
97707-40525	E- 6	98707-06025	B- 7						
97707-60114	B-13	98904-06012	C-11						
98503-03008	D- 2	99009-10400	B- 7						
98503-04014	B-10		C- 6						
98504-06025	B- 8	99009-12400	C- 7						
	B-15	99009-17400	C- 7						
	B-15	99009-20400	C- 5						
	B-15	99009-25500	B-15						
98504-06030	B-14	99080-07600	C- 6						
98504-06035	B-15	99235-00080	C- 9						
	B-15		C-10						
98504-06040	B-14	99236-00080	C- 9						
98504-06050	B-15		C-10						
98504-06070	B-14	99510-10114	B- 2						
	B-15		B-14						
98504-06080	B-14	99510-12016	B-14						
98504-06090	B- 8		B-15						
98506-05035	E- 7		B-15						
98506-05040	E- 7								
	E- 8								
98506-05045	E- 7								
	E- 8								
98506-06008	E- 7								
	E- 8								
98507-04035	E- 4								
98507-05008	D- 9								
	D-10								
98507-05010	C- 9								
98507-05016	D-15								
98507-05035	E- 8								
98507-06010	B-15								
	C-15								
	E- 9								
98507-06012	C- 8								
	D- 2								
98507-06016	E- 9								
98507-06025	B- 2								
	B- 7								
98507-06030	B-14								
	D-15								
98507-06040	B- 9								
98507-06060	B-14								
98507-06070	B-14								
98507-06080	B-14								

# **INDEX**

**(INDIVIDUAL SPEC.)**

NUMERICAL INDEX

PART NO.	GRID NO.	PART NO.	GRID NO.	PART NO.	GRID NO.	PART NO.	GRID NO.	PART NO.	GRID NO.
3LS-21610-00-MV	E-13 F- 3 F- 8	90387-100E2 90480-12013 92014-08012	F- 8 E-13 E-14						
3LS-21610-00-PO	E-13 F- 3 F- 8	92014-10050	F- 4 F-10 E-13						
3LS-21610-00-6G	E-13 F- 3 F- 8	92903-10200	F- 3 F- 8 E-13						
3LS-21621-00	E-13 F- 3 F- 8	92907-06200	F- 3 F- 8 E-13						
4G0-21639-00	E-13 F- 3 F- 8	92907-06600	F- 3 F- 8 E-13						
3LS-21640-00	F- 3 F- 8	95307-06600	F- 3 F- 8 E-13						
3LU-21640-00	E-13		E-13						
134-23484-10	F- 2 F- 6 F- 9	95707-06500	F- 3 F- 8 E-14						
2UJ-2471A-00	E-14 F- 4 F-10	98507-06012	F- 4 F-10 E-13						
509-24724-00	E-14 F- 4 F-10	98904-06014	F- 3 F- 8 E-13						
1J3-24742-00	E-13 F- 3 F- 8		F- 3 F- 8						
3LS-24750-00	E-14 F- 4 F-10								
3LS-24750-10	E-14 F- 4 F-10								
2UJ-24751-00	E-14 F- 4 F-10								
3DM-24751-10	E-14 F- 4 F-10								
3BG-82571-00	E-14								
90202-05193	E-13 F- 3 F- 8								
90387-100E2	E-13 F- 3								

*COPYRIGHT: All rights reserved. No part of this publication  
may be reproduced without permission.*

**YAMAHA**

YAMAHA MOTOR CO., LTD.  
2500 SHINGA | IWATA SHIZUOKA JAPAN  
SERVICE INFORMATION DIV.

---

Printed in Japan  
Second edition OCT.,1994