

YAMAHA



PARTS CATALOGUE

XV250S'97	(3LSH)	SPAIN
XV250S'97	(3LSJ)	EUROPE
XV250S'97	(3LU8)	SWITZERLAND
XV250'97	(4XT1)	BRAZIL

173LS-300E1

YAMAHA
GENUINE
Parts & Accessories

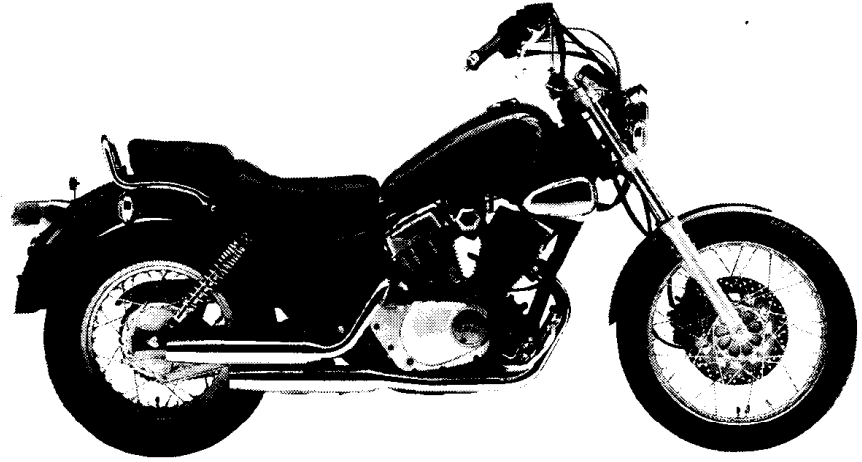
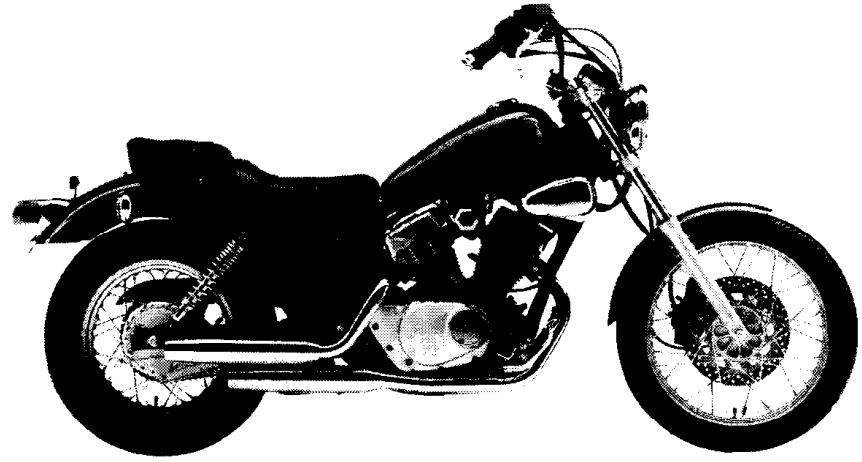

A3

FOREWORD

This Parts Catalogue is related to the parts for the model(s) in the below frame. When you are ordering replacement parts, please refer to this Parts Catalogue and quote both part numbers and part names correctly.

XV250S'97(3LSH/3LSJ/3LU8), XV250'97(4XT1)

1. Modifications or additions which have been made after issue of the Parts Catalogue will be announced in the Yamaha Parts News.
It is advisable that you make necessary corrections to the Parts Catalogue according to the Yamaha Parts News.

2. Abbreviations
The following abbreviations are used in this Parts Catalogue.

- "UR" Use specified parts number.
- "UN" Use as many as needed.
- "AP" Alternate Parts
- "LM" Local Made (Parts need to be ordered locally)
- "F#" Frame No. (Applicable machine No.)

3. Parts, which are to be supplied in an assembly, are listed with a dot (.) in front of the part name as shown below.

EXAMPLE
 CARBURETOR ASSY
 . JET, PILOT
 . NOZZLE, MAIN

4. Number of component for assembly
The numeral appearing to the right of each component part indicates the quantity of parts for each assembly unit.

EXAMPLE

PART NO.	DESCRIPTION	Q'TY	REMARKS
2F5-83310-60	FRONT FLASHER LIGHT ASSY	2	
115-83311-60	. BULB (6V-18W)	1	

5. Applicable colors of graphics are represented in the "REMARKS" as shown below.

PART NO.	DESCRIPTION	Q'TY	REMARKS
2N4-24110-00-XS	FUEL TANK COMP.	1	MAXIM RED
3J1-24240-10	. GRAPHIC, FUEL TANK	1	for MXR

6. Applicable Serial No.

① Engine Serial No.

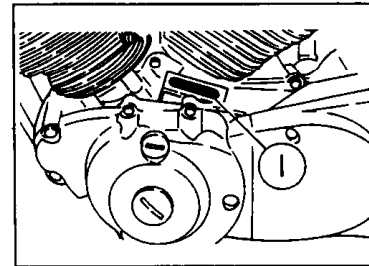

② Frame Serial No.

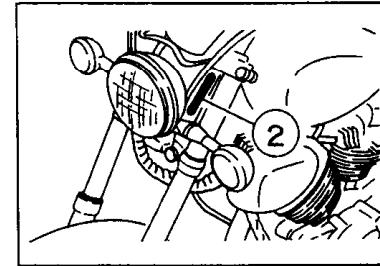

7. Note that the illustrations are for reference in finding parts numbers, not to be used for assembling. When assembling, please use the applicable service manual.
8. The asterisk (*) before a reference number indicates modification items after the first edition.

MODEL LABEL

(1) A label called "Model Label" is affixed in the location as indicated in (3) below. When using this parts catalogue, please be sure to cross-refer the "model code – production code No." in the catalogue to the "model code – production code No." indicated on the Model Label affixed onto the product concerned.

(2) "Model Label" Indication

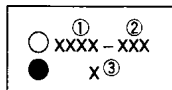

- ① Model Type Code
- ② Production Code No.
- ③ Colouring Type

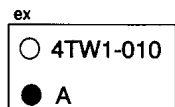

(3) Model Label Affixing Location

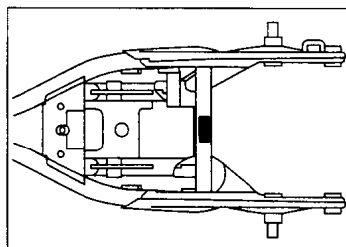

(4) Model Code – Production Code Number of Model Listed in This Parts Catalog

Model code	Production code No.	Country (destination)	Model code	Production code No.	Country (destination)
3LSH	010	SPAIN			
3LSJ	010	BELGIUM			
	020	DENMARK			
	030	FINLAND			
	050	ENGLAND			
	060	GREECE			
	070	ITALY			
	080	HOLLAND			
	090	PORTUGAL			
	100	SWEDEN			
3LU8	010	SWITZERLAND			
4XT1	010	BRAZIL			

(5) Colouring Information

Model code	Colouring type code	Colour code	Colour Name	Abbreviation
3LSH	A	00EG	MAPLE RED	MPR
3LSJ	B	007M	MIDNIGHT SILVER	MDS
3LU8				
4XT1	A	004B	BLACK 2	BL2

CONTENTS

GENERAL SPEC.

ENGINE

Cylinder Head	B2
Cylinder	B3
Crankshaft. Piston	B4
Valve	B5
Camshaft. Chain	B6
Oil Pump	B7
Oil Cleaner	B8
Intake	B9
Carburetor	B10~B11
Exhaust	B12~B13
Crankcase	B14
Crankcase Cover 1	B15
Starter Clutch	C2
Clutch	C3~C4
Transmission	C5
Shift Cam. Fork	C6
Shift Shaft	C7

CHASSIS

Frame	C8
Fender	C9~C10
Side Cover	C11
Rear Arm	C12
Steering	C13~C14
Front Fork	C15~D2
Fuel Tank	D3~D4
Seat	D5
Front Wheel	D6
Front Brake Caliper	D7

Rear Wheel	D8~D9
Steering Handle. Cable	D10
Front Master Cylinder	D11
Stand. Footrest	D12~D14
Generator	D15
Starting Motor	E2
Flasher Light	E3
Meter	E4
Headlight	E5
Taillight	E6
Handle Switch. Lever	E7
Electrical 1	E8~E9
Electrical 2	E10

INDEX (GENERAL SPEC.)

Numerical Index	L2~L5
-----------------------	-------

INDIVIDUAL SPEC.

FOR SWITZERLAND

Alternate (Front Fork)	E12
------------------------------	-----

FOR ITALY

Alternate (Front Fork)	E14
Alternate (Fender)	E15
Alternate (Seat)	F2

FOR SPAIN

Alternate (Fender)	F4
Alternate (Seat)	F5

FOR ENGLAND

Alternate (Fender)	F7
Alternate (Seat)	F8
Alternate (Meter)	F9
Alternate (Headlight)	F10

FOR BRAZIL

Alternate (Fender)	F12~F13
Alternate (Flasher Light)	F14

INDEX (INDIVIDUAL SPEC.)

Numerical Index	M2
-----------------------	----

GENERAL SPEC.

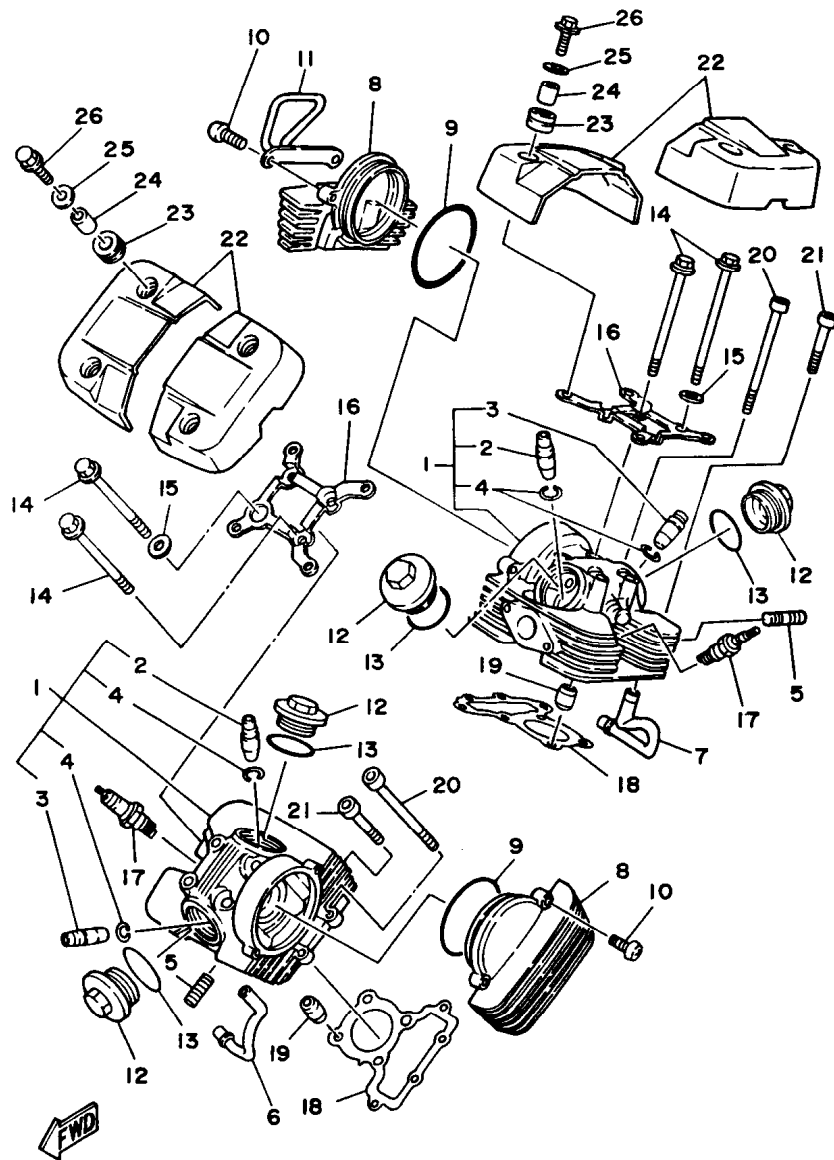

3LS1300-9010

FIG. 1 CYLINDER HEAD

REF. NO.	PART NO.	DESCRIPTION	Q'TY	REMARKS
1	2UJ-11102-00	CYLINDER HEAD ASSY	2	UR
	3BG-11102-00	CYLINDER HEAD ASSY	2	UR FOR SWITZERLAND
2	2UJ-11133-10	.GUIDE, intake valve	1	
3	22F-11134-10	.GUIDE, exhaust valve	1	
4	93440-10109	.CIRCLIP	2	
5	90116-06228	BOLT, stud	4	
6	3BG-14871-00	PIPE 1	1	FOR SWITZERLAND
7	3BG-14872-00	PIPE 2	1	FOR SWITZERLAND
8	2UJ-11185-01	COVER, cylinder head side 1	2	
9	93210-78544	O-RING	2	
10	98507-06025	SCREW, pan head	4	
11	2UJ-11152-00	BRACKET, cylinder head cover	1	
12	22F-11186-00	COVER, cylinder head side 2	4	
13	93210-44704	O-RING	4	
14	90105-08324	BOLT, washer based	8	
15	90201-080L7	WASHER, plate	2	
16	2UJ-11142-00	BRACKET, cylinder head cover 2	2	
17	94701-00282	PLUG SPARK (NGK CR6HS)	2	UR
	94701-00283	PLUG, spark (ND U20FSR-U)	2	UR
18	2UJ-11181-01	GASKET, cylinder head 1	2	
19	99510-10114	PIN, dowel	4	
20	91317-06110	BOLT	4	
21	91317-06040	BOLT	4	
22	2UJ-11186-00	COVER, cylinder head side 2	4	
23	90480-13018	GROMMET	8	
24	90387-066M3	COLLAR	8	
25	90201-06697	WASHER, plate	8	
26	95024-06020	BOLT	8	

FIG. 2 CYLINDER

REF. NO.	PART NO.	DESCRIPTION	Q'TY	REMARKS
1	2UJ-11310-01	CYLINDER	1	UR
	3BG-11310-00	CYLINDER	1	UR FOR SWITZERLAND
2	2UJ-11320-01	CYLINDER 2	1	UR
	3BG-11320-00	CYLINDER 2	1	UR FOR SWITZERLAND
3	15A-11162-00	ABSORBER 2	8	FOR SWITZERLAND
4	3DM-11351-00	GASKET, cylinder	2	
5	93210-53679	O-RING	2	

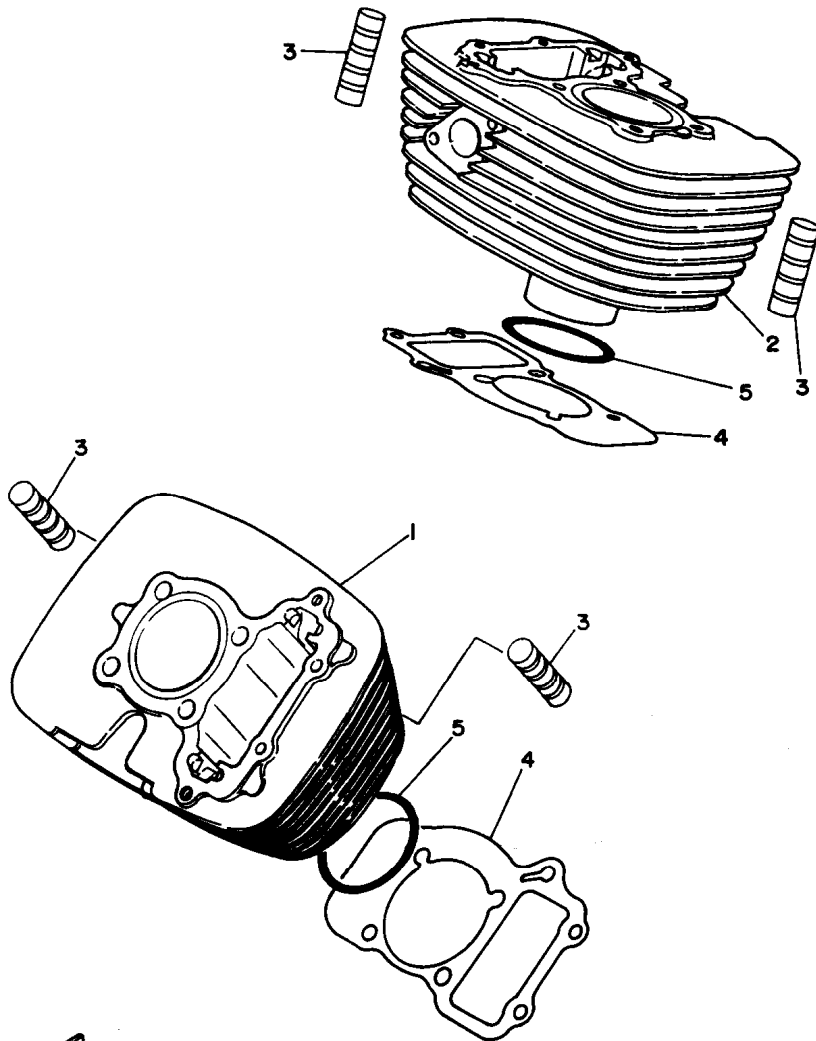

3LS2300-2020

B3

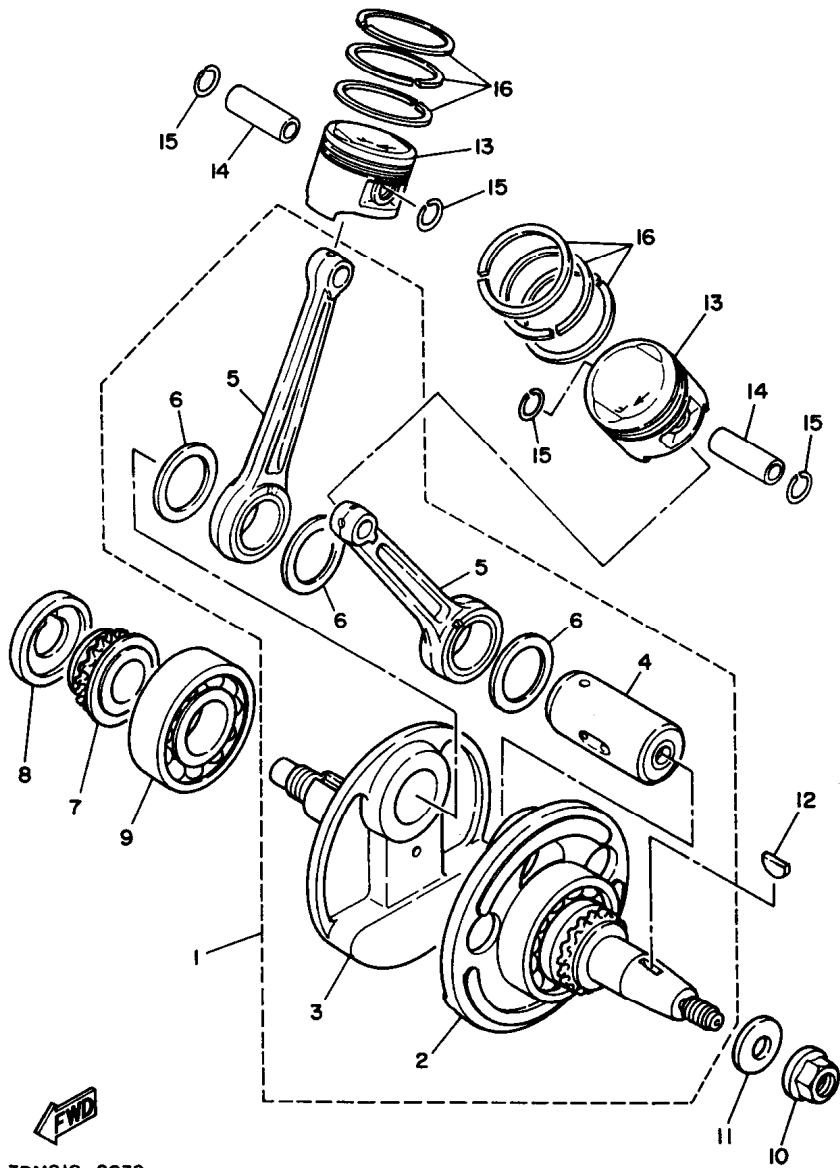

3DM010-8030

FIG. 3 CRANKSHAFT. PISTON

REF. NO.	PART NO.	DESCRIPTION	Q'TY	REMARKS
1	2UJ-11400-00	CRANKSHAFT ASSY	1	
2	2UJ-W1141-00	.CRANK 1	1	
3	2UJ-11422-00	.CRANK 2	1	
4	2UJ-11681-00	.PIN, crank 1	1	
5	2UJ-11651-00	.ROD, connecting	2	
6	90209-31300	.WASHER	3	
7	2UJ-1154A-00	SPROCKET, cam chain 2	1	
8	2UJ-11478-00	COLLAR	1	
9	93306-30615	BEARING (B6306)	1	
10	90179-12248	NUT	1	
11	90201-12191	WASHER, plate	1	
12	90280-16053	KEY, woodruff	1	
13	2UJ-11631-00-A0	PISTON (STD)	2	
	2UJ-11636-00	PISTON (0.50MM O/S)	2	AP
	2UJ-11638-00	PISTON (1.00MM O/S)	2	AP
14	22K-11633-01	PIN, piston	2	
15	93450-14088	CIRCLIP	4	
16	50M-11610-00	PISTON RING SET (STD)	2	
	50M-11610-20	PISTON RING SET (0.50MM O/S)	2	AP
	50M-11610-40	PISTON RING SET (1.00MM O/S)	2	AP

B4

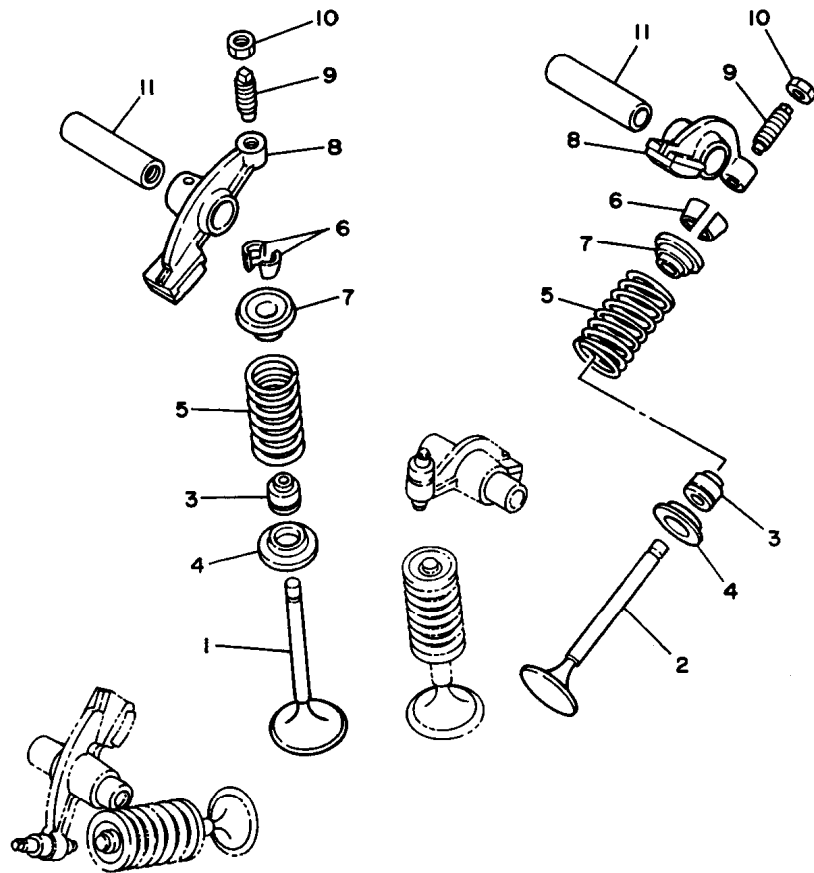

FIG. 4 VALVE

REF. NO.	PART NO.	DESCRIPTION	Q'TY	REMARKS
1	50M-12111-00	VALVE, intake	2	
2	50M-12121-01	VALVE, exhaust	2	
3	22F-12119-01	SEAL, valve stem	4	
4	22F-12116-00	SEAT, valve spring	4	
5	2UJ-12114-00	SPRING, valve outer	4	
6	22F-12118-01	COTTER, valve	8	
7	22F-12117-02	RETAINER, valve spring	4	
8	50M-12151-00	ARM, valve rocker	4	
9	22F-12159-00	SCREW, valve adjusting	4	
10	90170-05302	NUT	4	
11	22F-12156-00	SHAFT, rocker 2	4	



3DM010 - 8040

B5

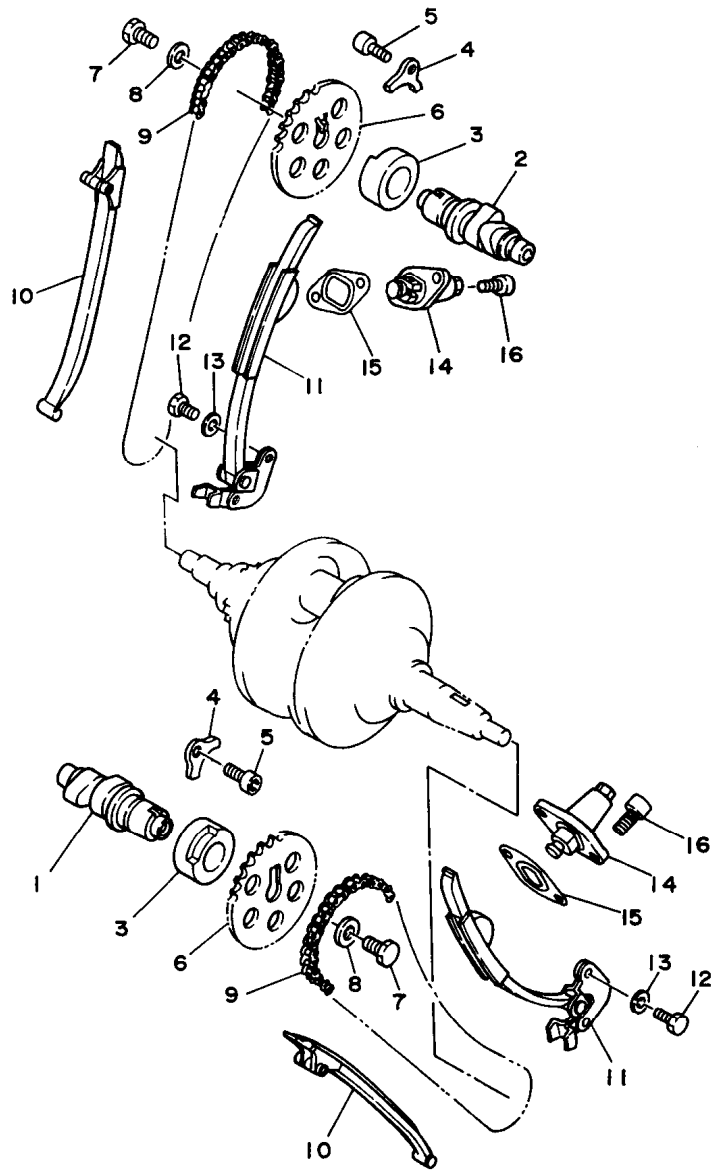

FIG. 5 CAMSHAFT. CHAIN

REF. NO.	PART NO.	DESCRIPTION	Q'TY	REMARKS
1	2UJ-12171-00	CAMSHAFT 1	1	
2	2UJ-12181-00	CAMSHAFT 2	1	
3	90381-22070	BUSH, solid	2	
4	2UJ-1111F-00	PLATE	2	
5	91317-06012	BOLT	2	
6	2UJ-12176-00	SPROCKET, cam chain	2	
7	90101-08590	BOLT	2	
8	90201-08326	WASHER, plate	2	
9	94580-25110	CHAIN	2	
10	2UJ-12231-00	GUIDE, stopper 1	2	
11	2UJ-12241-00	GUIDE, stopper 2	2	
12	97027-06012	BOLT	4	
13	92907-06600	WASHER, plate	4	
14	2UJ-12210-01	TENSIONER ASSY, cam chain	2	
15	3DM-12213-00	GASKET, tensioner case	2	
16	91314-06016	BOLT	4	



3DM010-8050

B6

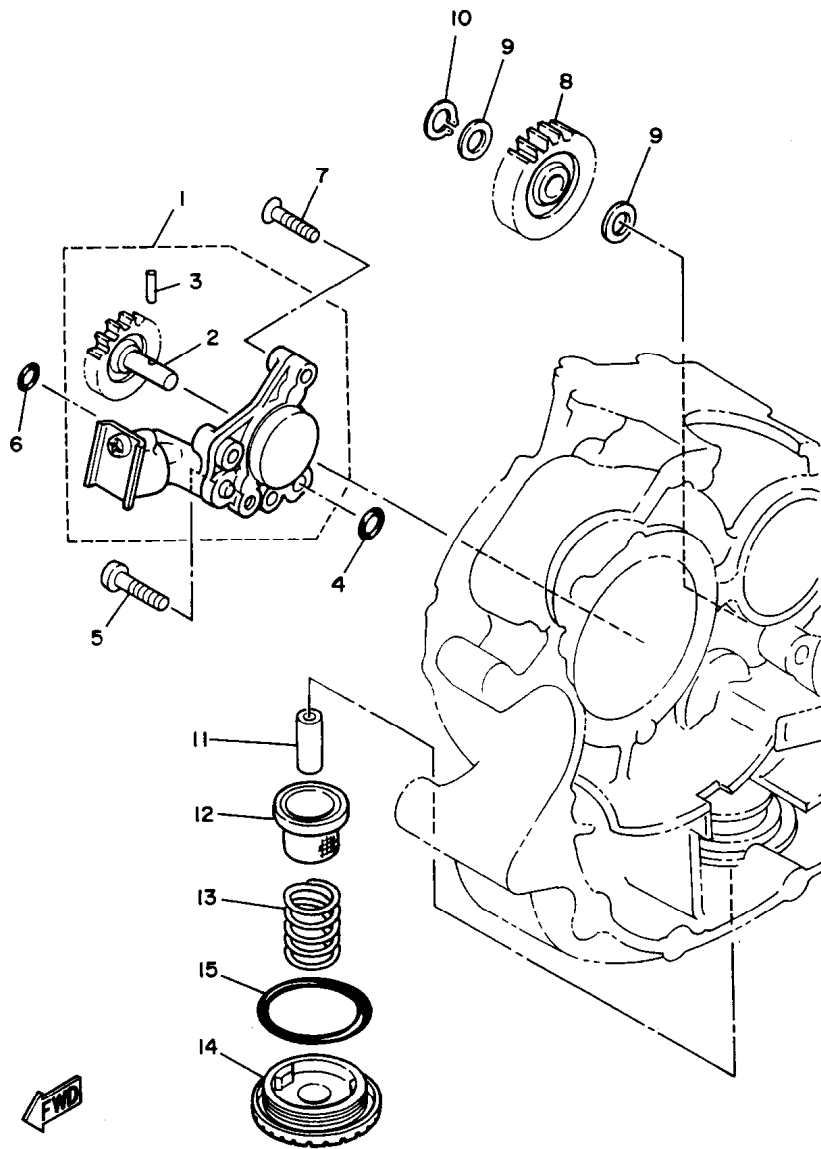

3DM010-8060

FIG. 6 OIL PUMP

REF. NO.	PART NO.	DESCRIPTION	Q'TY	REMARKS
1	2UJ-13300-00	OIL PUMP ASSY	1	
2	3Y6-13326-01	.GEAR, pump driven 2 (23T)	1	
3	93603-12030	.PIN, dowel	1	
4	93210-10096	O-RING	1	
5	98507-06025	SCREW, pan head	2	
6	93210-06245	O-RING	1	
7	98707-06025	SCREW, flat head	1	
8	2UJ-13341-00	GEAR, oil pump idle	1	
9	90201-10119	WASHER, plate	2	
10	99009-10400	CIRCLIP	1	
11	2XK-13416-00	PIPE, oil 1	1	
12	51Y-13411-00	STRAINER, oil	1	
13	90501-18576	SPRING, compression	1	
14	30X-15351-00	PLUG, drain	1	
15	93210-35389	O-RING	1	

B7

FIG. 7 OIL CLEANER

REF. NO.	PART NO.	DESCRIPTION	Q'TY	REMARKS
1	4X7-13440-90	ELEMENT ASSY, oil cleaner	1	
2	3DM-13447-00	COVER, oil element	1	
3	93210-64297	O-RING	1	
4	98504-06090	SCREW, pan head	1	
5	98504-06025	SCREW, pan head	2	

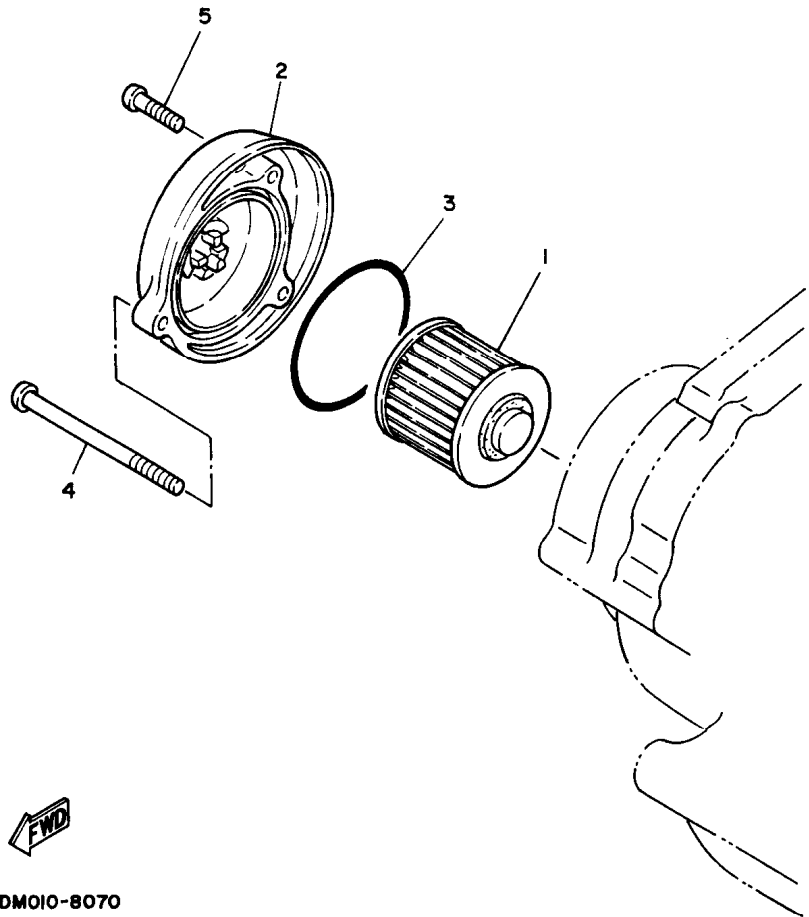

3DM010-8070

B8

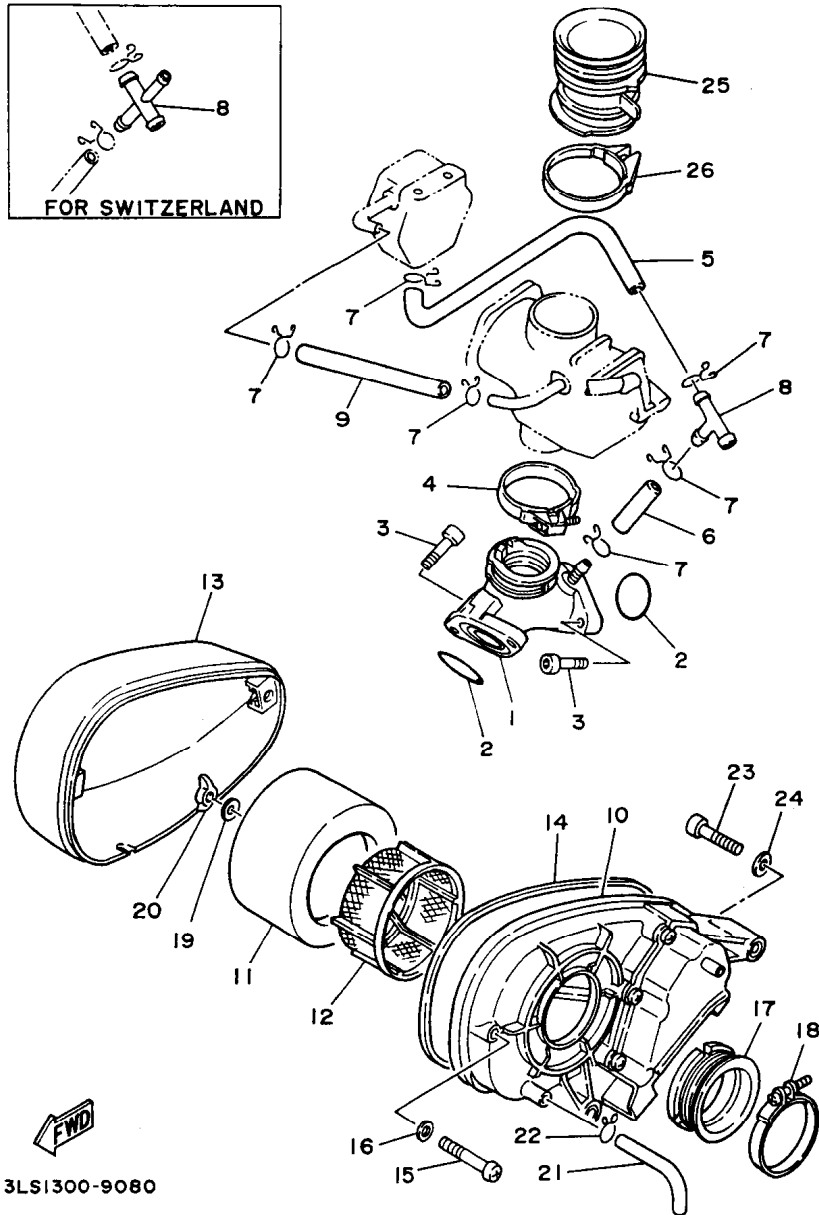
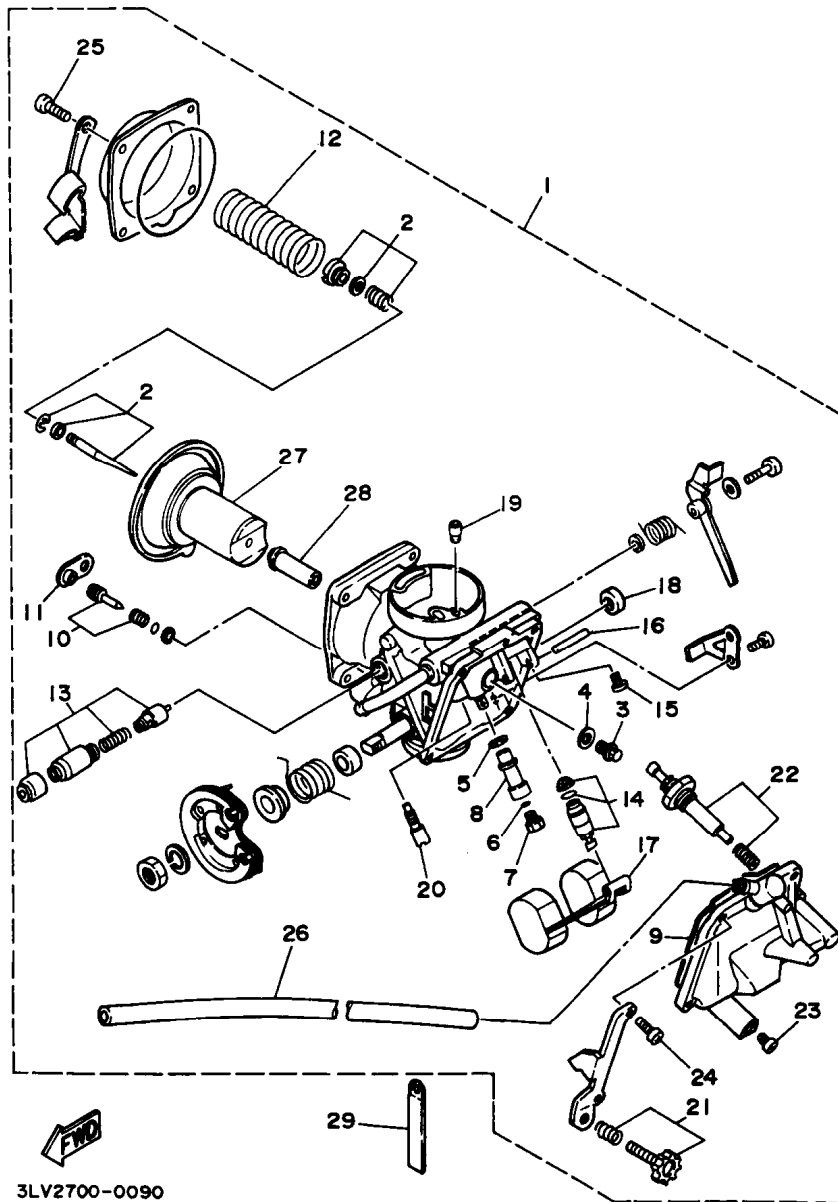

FIG. 8 INTAKE

REF. NO.	PART NO.	DESCRIPTION	Q'TY	REMARKS
1	2UJ-13586-00	JOINT, carburetor 1	1	
2	93210-30611	O-RING	2	
3	91317-06020	BOLT	4	
4	1HX-13575-00	BAND	1	
5	2UJ-13978-00	PIPE, regulator	1	
6	90445-11763	HOSE	1	
7	90467-10008	CLIP	6	
8	90413-07007	WAY 3	1	UR
	38G-13595-00	JOINT	1	UR FOR SWITZERLAND
9	90445-117F0	HOSE	1	
10	2UJ-14401-00	AIR CLEANER CASE ASSY	1	
11	2UJ-14451-00	ELEMENT, air cleaner	1	
12	2UJ-14458-00	GUIDE	1	
13	2UJ-14422-00	CAP, cleaner case 2	1	
14	2UJ-14452-00	SEAL	1	
15	98507-06040	SCREW, pan head	2	
16	92907-06600	WASHER, plate	2	
17	2UJ-14485-00	PIPE, joint	1	
18	90460-54111	CLAMP, hose	1	
19	90201-05036	WASHER, plate	1	
20	90175-05005	NUT, wing	1	
21	2UJ-14419-00	PIPE	1	
22	90467-11106	CLIP	1	
23	91317-06025	BOLT	2	
24	92907-06600	WASHER, plate	2	
25	2UJ-14469-00	FUNNEL, air	1	
26	90460-54137	CLAMP, hose	1	

B9



3LV2700-0090

FIG. 9 CARBURETOR

REF. NO.	PART NO.	DESCRIPTION	Q'TY	REMARKS
1	3DM-14900-10	CARBURETOR ASSY	1	UR
	3LU-14900-10	CARBURETOR ASSY	1	UR FOR SWITZERLAND
	4XT-14900-00	CARBURETOR ASSY	1	UR FOR BRAZIL
2	3DM-1490J-00	.NEEDLE SET	1	UR
	3BG-1490J-00	.NEEDLE SET	1	UR FOR SWITZERLAND
3	1HX-14565-00	.SCREW	1	
4	137-14153-00	.WASHER, main jet	1	
5	1AE-14237-00	.GASKET	1	
6	1AE-14227-00	.O-RING	1	
7	620-14231-22-A0	.JET, main (#110)	1	UR
	620-1423A-73	.JET, main (#112.5)	1	UR BRAZIL
8	1AE-14261-00	.HOLDER	1	
9	1HX-14147-00	.O-RING	1	
10	12R-14105-00	.PILOT SCREW SET	1	
11	22F-14991-00	.CAP	1	UR
	2RJ-14118-00	.CAP	1	UR FOR SWITZERLAND
	3F9-14118-00	.CAP	1	UR FOR BRAZIL
12	1HX-14933-00	.SPRING, diaphragm	1	
13	3DM-1410A-10	.STARTER SET	1	
14	3CF-14107-10	.NEEDLE VALVE SET	1	UR
	3DM-14107-19	.NEEDLE VALVE SET	1	UR FOR BRAZIL
15	1FN-14565-00	.SCREW	1	
16	353-14186-00	.PIN, float	1	
17	1HX-14985-00	.FLOAT	1	
18	256-14997-00	.SEAL	1	
19	1HX-14231-31	.JET, main (#155)	1	
20	22F-14142-17	.JET, pilot (#17.5)	1	UR
	22F-14142-20	.JET, pilot (#20)	1	UR FOR BRAZIL

Bio

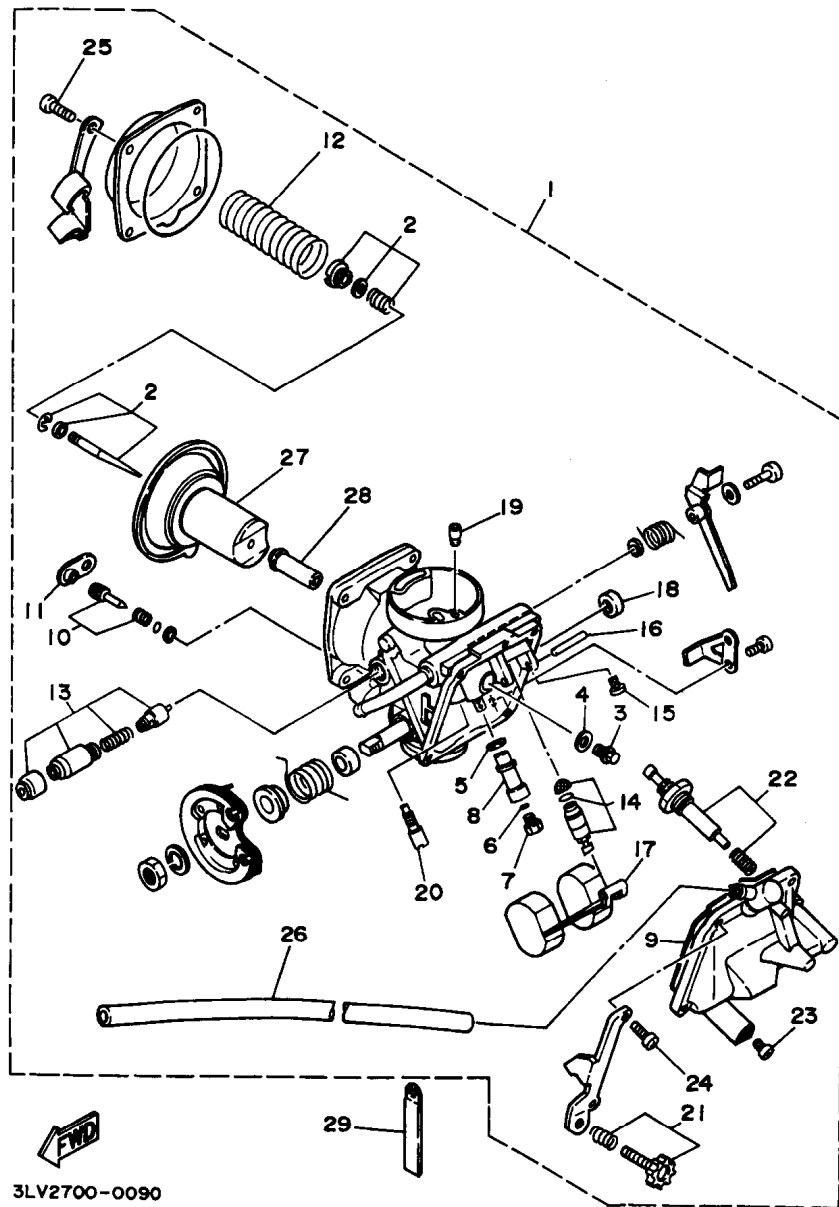

3LV2700-0090

FIG. 9 CARBURETOR

REF. NO.	PART NO.	DESCRIPTION	Q'TY	REMARKS
21	1HX-14103-00	.THROTTLE SCREW SET	1	
22	3DM-14504-01	.ROD SET	1	
23	12R-14191-00	.PLUG, drain	1	
24	98503-04014	.SCREW, pan head	2	
25	98511-04012	.SCREW, pan head	4	
26	2LH-14197-00	.PIPE	1	
27	3BG-14940-00	.DIAPHRAGM ASSY	1	UR
	4XT-14940-00	.DIAPHRAGM ASSY	1	UR FOR BRAZIL
28	3DM-14141-30	.MAIN NOZZLE (0-0)	1	
29	90461-06087	CLAMP	1	

B11

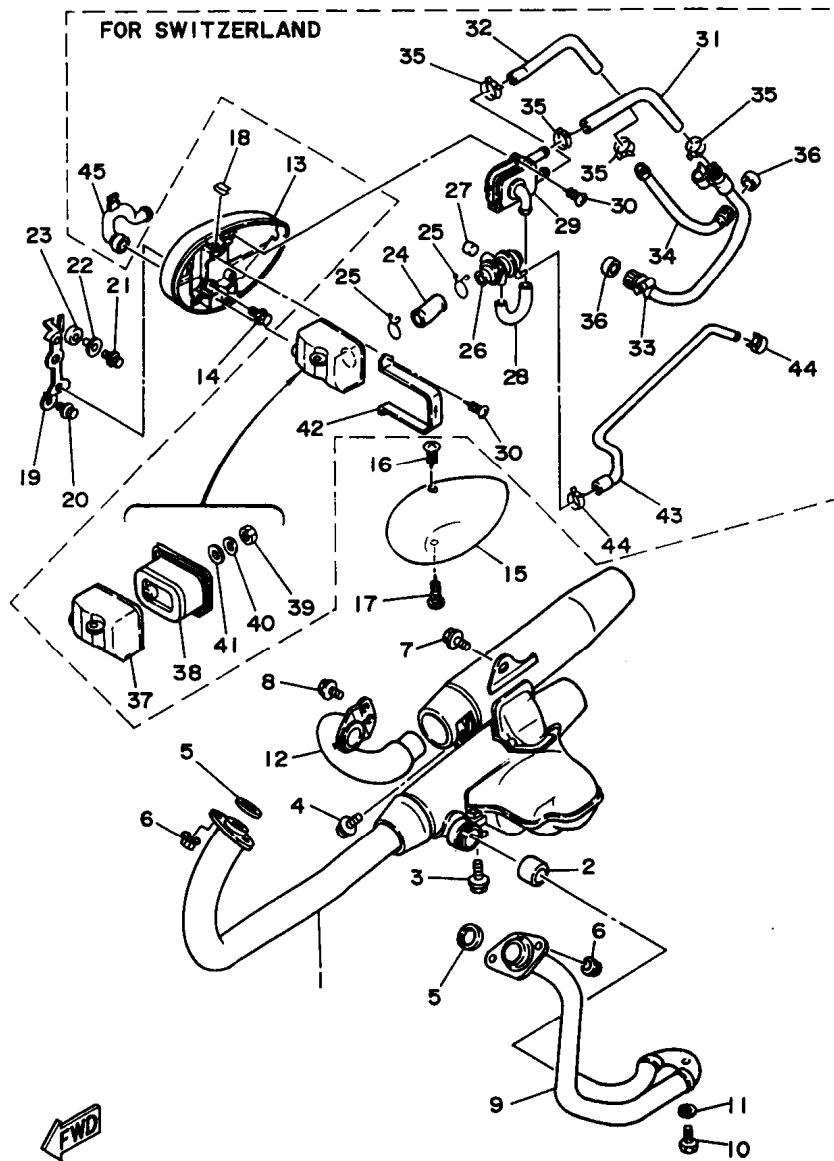

3LS1300-9100



FIG. 10 EXHAUST

REF. NO.	PART NO.	DESCRIPTION	Q'TY	REMARKS
1	3DM-14703-11	MUFFLER COMP 1	1	UR
	3LU-14703-01	MUFFLER COMP 1	1	UR FOR SWITZERLAND
2	4FU-14714-00	GASKET, muffler	1	
3	95817-08035	BOLT, flange	1	
4	95807-06025	BOLT, flange	1	
5	3DM-14613-00	GASKET, exhaust pipe	2	
6	90179-06668	NUT	4	
7	95807-10014	BOLT, flange	1	
8	95807-08012	BOLT, flange	2	
9	2UJ-14621-00	PIPE, exhaust 2	1	
10	90101-06576	BOLT	1	
11	92990-06600	WASHER, plate	1	
12	2UJ-14631-00	PIPE, exhaust 3	1	
13	2GV-14663-00	PLATE, air cleaner	1	
14	95807-06020	BOLT, flange	2	
15	2GV-14603-00	COVER 1	1	
16	97704-40012	SCREW, tapping	1	
17	90163-04003	SCREW, tapping	1	
18	90183-04027	NUT, spring	2	
19	2UJ-14484-00	PLATE, cleaner case fitting	1	UR
	4XT-E4484-00	PLATE, cleaner case fitting	1	UR FOR BRAZIL
20	95807-06010	BOLT, flange	1	
21	95807-06025	BOLT, flange	1	
22	90387-07391	COLLAR	1	
23	90385-10026	BUSH	1	
24	3BM-14882-00	HOSE, bend 2	1	
25	90467-26111	CLIP	2	FOR SWITZERLAND
26	3BG-14840-00	AIR CUT VALVE ASSY	1	

B12

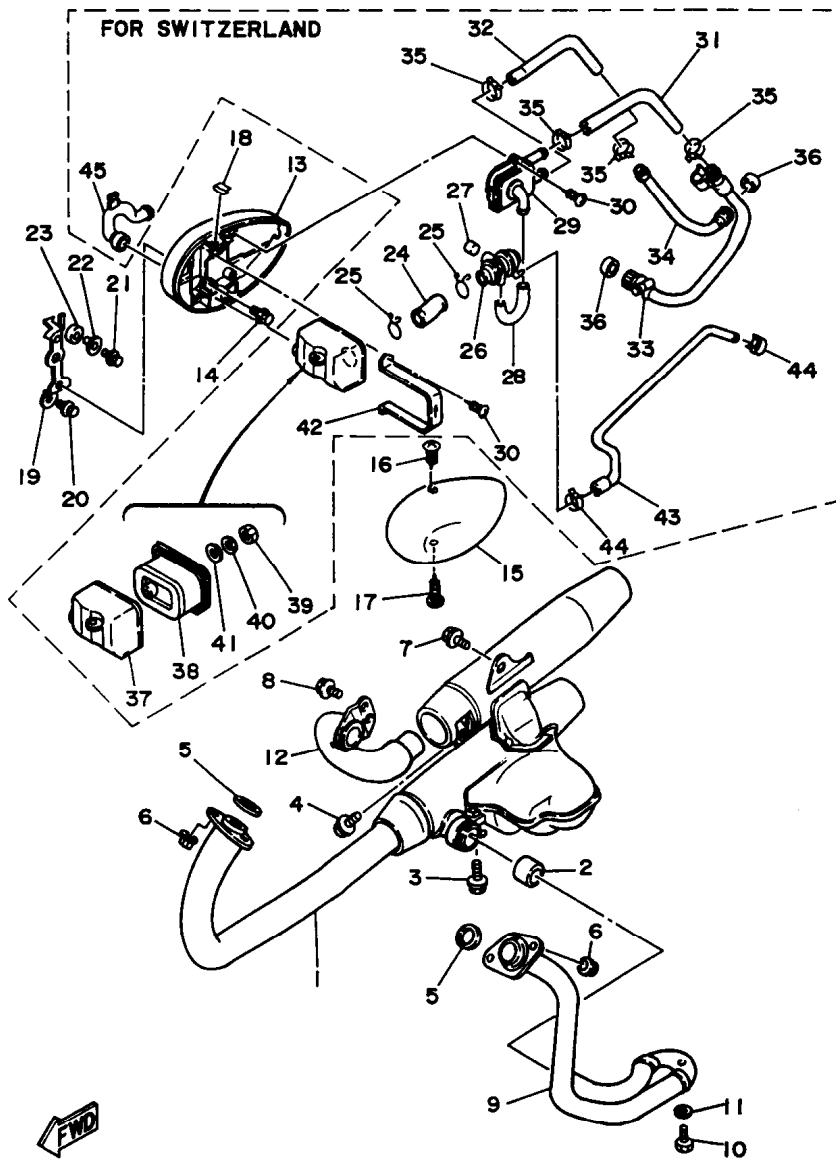

3LS1300-9100

FIG. 10 EXHAUST

REF. NO.	PART NO.	DESCRIPTION	Q'TY	REMARKS
27	90338-10132	PLUG	1	
28	38M-14883-00	HOSE, bend 3	1	
29	42H-14808-00	REED VALVE ASSY	1	
30	97707-60114	SCREW, tapping	5	
31	38G-14884-00	HOSE, bend 4	1	
32	38G-14885-00	HOSE, bend 5	1	
33	38G-14873-00	PIPE 3	1	
34	38G-14874-00	PIPE 4	1	
35	90468-08104	CLIP	4	
36	42H-14714-10	GASKET, muffler	2	FOR SWITZERLAND
37	42H-14857-00	CASE, air cleaner	1	
38	38G-14858-00	CAP, case	1	
39	95307-05600	NUT	1	
40	92907-05200	WASHER, plain	1	
41	90202-05057	WASHER, plate	1	
42	38M-14867-00	BRACKET	1	
43	38G-13542-00	HOSE, vacuum sensing 1	1	
44	90467-08092	CLIP	2	
45	1TA-14881-00	HOSE, bend 1	1	

B13

FIG. 11 CRANKCASE

REF. NO.	PART NO.	DESCRIPTION	Q'TY	REMARKS
1	2UJ-15100-02	CRANKCASE ASSY	1	
2	99510-12016	.PIN, dowel	2	
3	2UJ-15138-00	NOZZLE 1	2	
4	99510-10114	PIN, dowel	4	
5	98504-06030	SCREW, pan head	4	
6	98504-06030	SCREW, pan head	1	
7	98504-06040	SCREW, pan head	1	
8	98507-06060	SCREW, pan head	2	
9	98507-06070	SCREW, pan head	1	
10	98504-06070	SCREW, pan head	1	
11	98507-06080	SCREW, pan head	3	
12	98504-06080	SCREW, pan head	1	
13	90465-08277	CLAMP	1	
14	2UJ-11166-00	PIPE, breather 1	1	
15	90467-14015	CLIP	2	
16	2UJ-12279-00	PLATE	1	
17	97027-06012	BOLT	2	
18	92907-06600	WASHER, plate	2	
19	90465-08158	CLAMP	1	
20	3VD-13455-00	PLUG	1	
21	214-11198-01	GASKET	1	
22	90153-06029	SCREW, hexagon	1	
23	90430-06014	GASKET	3	

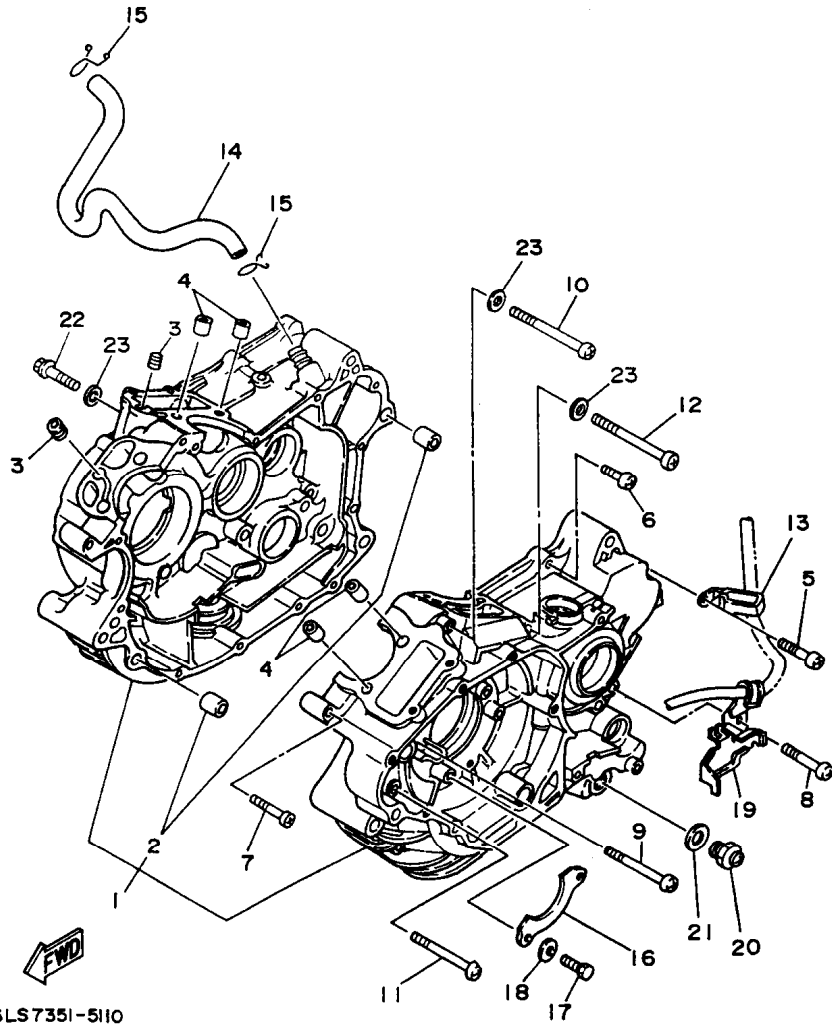

3LS7351-5110

B14

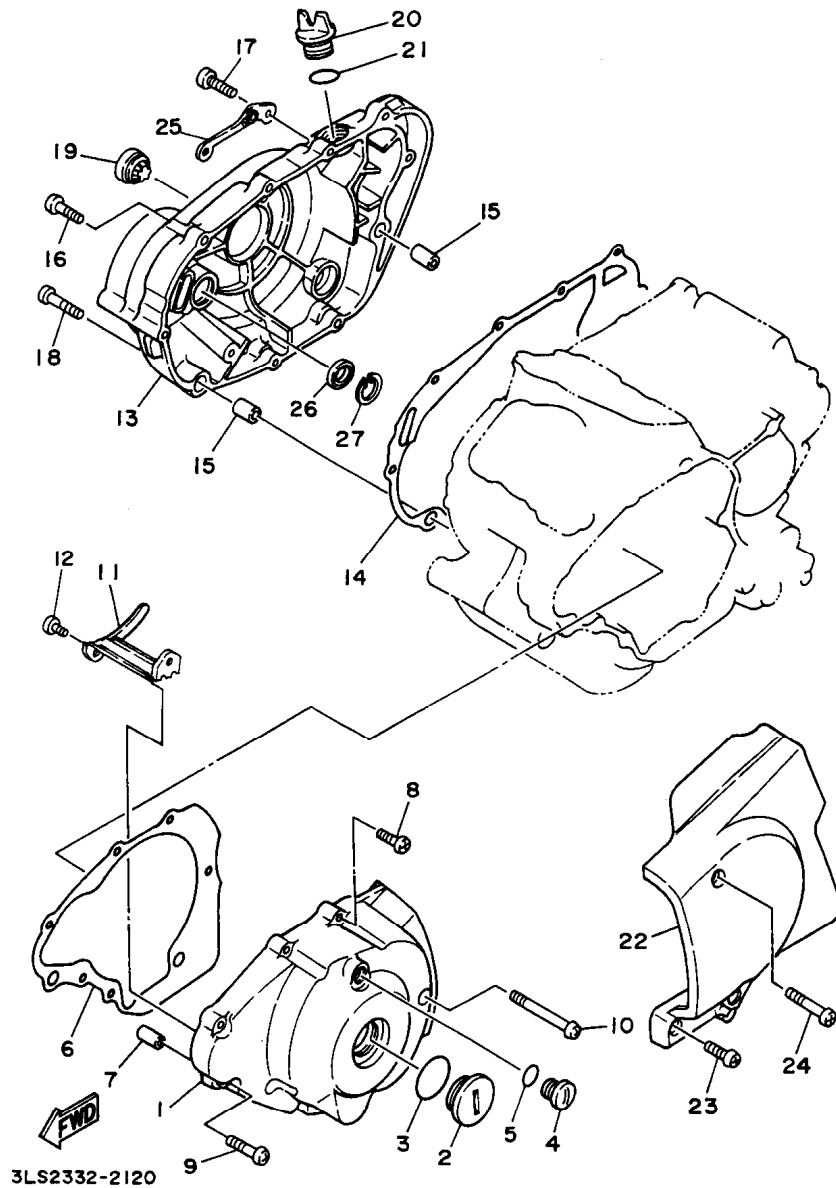

3LS2332-2120

FIG. 12 CRANKCASE COVER 1

REF. NO.	PART NO.	DESCRIPTION	Q'TY	REMARKS
1	3DM-15411-01	COVER, crankcase 1	1	
2	90340-32088	PLUG, straight screw	1	
3	93210-32172	O-RING	1	
4	90340-14068	PLUG, straight screw	1	
5	93210-14369	O-RING	1	
6	3DM-15451-00	GASKET, crankcase cover 1	1	
7	99510-12016	PIN, dowel	2	
8	98504-06025	SCREW, pan head	5	
9	98504-06035	SCREW, pan head	2	
10	98504-06070	SCREW, pan head	1	
11	90465-06322	CLAMP	1	
12	98507-06010	SCREW, pan head	1	
13	3DM-15421-00	COVER, crankcase 2	1	
14	3DM-15461-00	GASKET, crankcase cover 2	1	
15	99510-12016	PIN, dowel	2	
16	98504-06025	SCREW, pan head	5	
17	90153-06042	SCREW, hexagon	2	
18	98504-06035	SCREW, pan head	2	
19	3Y1-15361-00	GAUGE, level	1	
20	1RG-15363-00	PLUG, oil	1	
21	93210-19123	O-RING	1	
22	3DM-15431-00	COVER, crankcase 3	1	
23	98504-06025	SCREW, pan head	2	
24	98504-06050	SCREW, pan head	1	
25	2UJ-15441-00	HOLDER, clutch cable	1	
26	93101-14089	OIL SEAL	1	
27	99009-25500	CIRCLIP	1	

FIG. 13 STARTER CLUTCH

REF. NO.	PART NO.	DESCRIPTION	Q'TY	REMARKS
1	2UJ-15512-00	GEAR, idler 1	1	
2	5H0-15521-00	SHAFT 1	1	
3	2UJ-15517-00	GEAR, idler 2	1	
4	90201-25291	WASHER, plate	1	
5	51Y-15590-01	STARTER ONE-WAY ASSY	1	
6	91317-08018	BOLT	3	

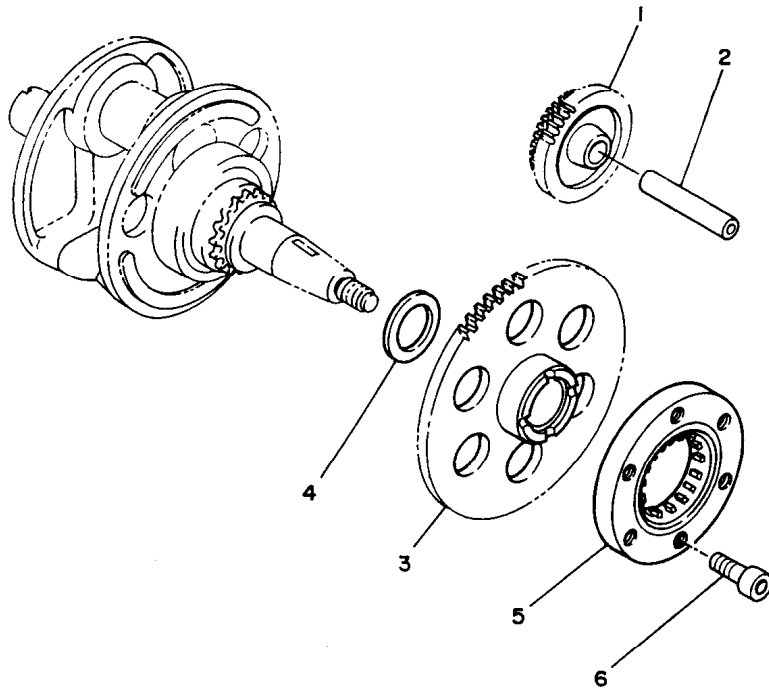

3DM010-8130

C2

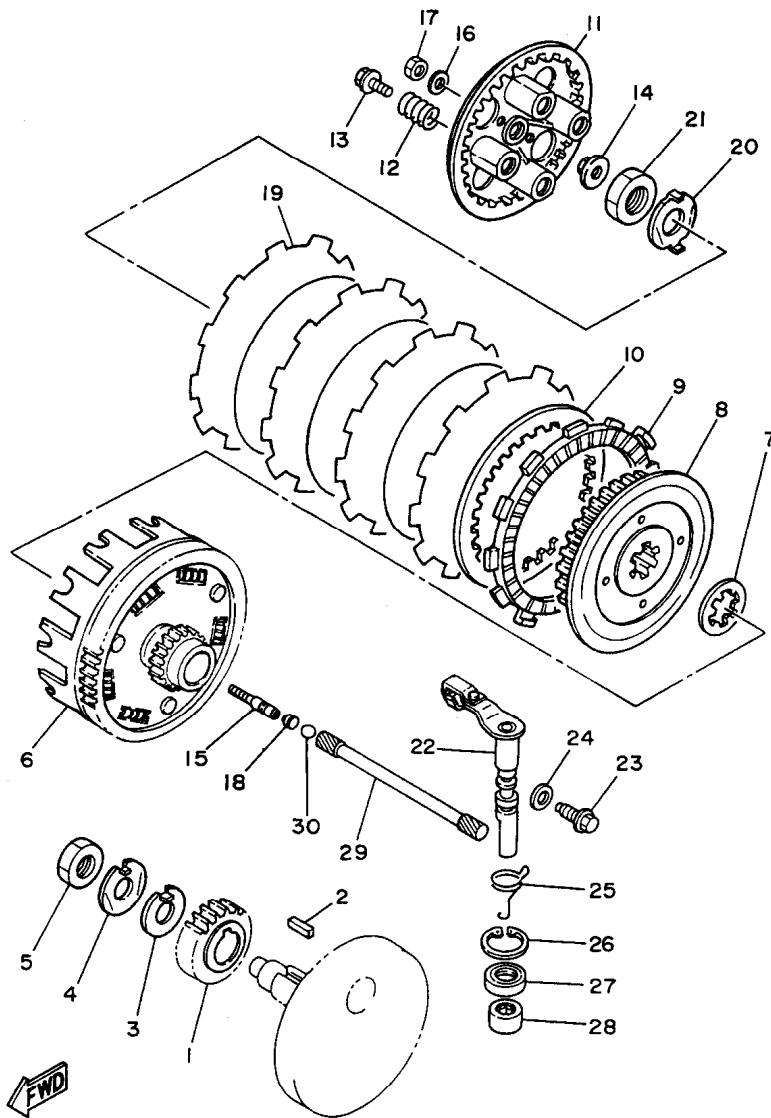

3LS7351-5140

FIG. 14 CLUTCH

REF. NO.	PART NO.	DESCRIPTION	Q'TY	REMARKS
1	3Y6-16111-03	GEAR, primary drive (23T)	1	
2	90282-07023	KEY, straight	1	
3	90215-16156	WASHER, lock	1	
4	90215-16222	WASHER, lock	1	
5	90170-16311	NUT	1	
6	2UJ-16150-00	PRIMARY DRIVEN GEAR COMP.	1	
7	30X-16154-00	PLATE, thrust 1	1	
8	30X-16371-00	BOSS, clutch	1	
9	5Y1-16331-01	PLATE, friction 2	4	
10	3J2-16324-00	PLATE, clutch 1	4	
11	30X-16351-01	PLATE, pressure 1	1	
12	90501-26148	SPRING, compression	4	
13	90159-06016	SCREW, with washer	4	
14	1W1-16358-01	PLATE, push	1	
15	4DN-16356-00	ROD, push 1	1	
16	92907-06200	WASHER, plain	1	
17	95307-06600	NUT	1	
18	3YX-1635A-00	SEAL, push rod	1	
19	31A-16321-01	PLATE, friction	1	
20	90215-16320	WASHER, lock	1	
21	90170-16326	NUT	1	
22	2UJ-16380-00	PUSH LEVER ASSY	1	
23	90149-08067	SCREW	1	
24	90201-08087	WASHER, plate	1	
25	90508-14433	SPRING, torsion	1	
26	93420-28055	CIRCLIP	1	
27	93102-14209	OIL SEAL	1	
28	93315-31428	BEARING, cylindrical	1	

C3

FIG. 14 CLUTCH

REF. NO.	PART NO.	DESCRIPTION	Q'TY	REMARKS
29	2UJ-16357-00	ROD, push 2	1	
30	93511-32027	BALL	1	

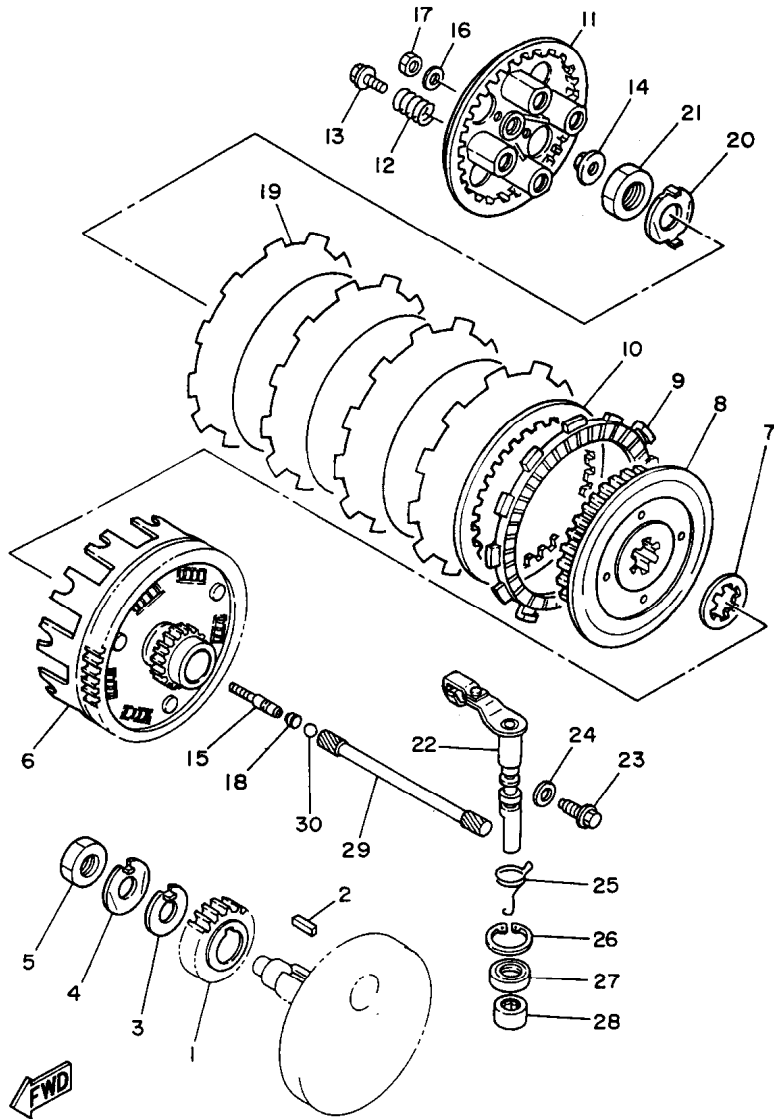

3LS735I-5140

C4

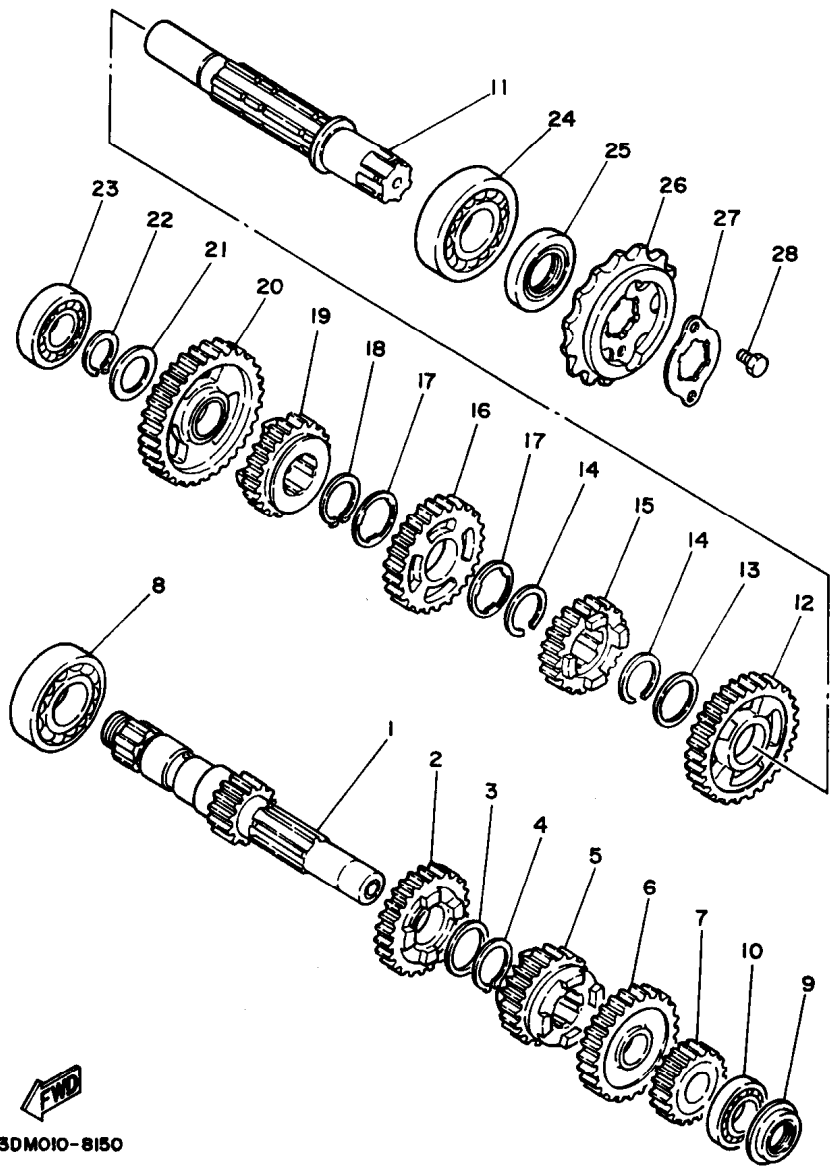

3DM010-8150

FIG. 15 TRANSMISSION

REF. NO.	PART NO.	DESCRIPTION	Q'TY	REMARKS
1	4DN-17411-00	AXLE, main	1	
2	3Y1-17141-00	GEAR, 4th pinion (26T)	1	
3	90201-22793	WASHER, plate	1	
4	93410-22039	CIRCLIP	1	
5	3Y1-17131-01	GEAR, 3rd pinion (23T)	1	
6	3Y1-17151-00	GEAR, 5th pinion (28T)	1	
7	3Y1-17121-01	GEAR, 2nd pinion (19T)	1	
8	93306-20541	BEARING (B6205)	1	
9	93101-17093	OIL SEAL	1	
10	93306-00302	BEARING	1	
11	3Y1-17402-00	DRIVE AXLE ASSY	1	
12	3Y1-17221-01	GEAR, 2nd wheel (32T)	1	
13	90201-253K0	WASHER, plate (T=1.0)	1	
14	93440-25084	CIRCLIP	2	
15	3Y1-17251-01	GEAR, 5th wheel	1	
16	3Y1-17231-01	GEAR, 3rd wheel (29T)	1	
17	90209-22191	WASHER	2	
18	99009-25400	CIRCLIP	1	
19	3Y1-17241-00	GEAR, 4th wheel (26T)	1	
20	3Y1-17211-00	GEAR, 1st wheel (37T)	1	
21	90201-20276	WASHER, plate (1.0T)	1	
22	99009-20400	CIRCLIP	1	
23	93306-00426	BEARING	1	
24	93306-30525	BEARING (B6305)	1	
25	93102-25208	OIL SEAL	1	
26	3DM-17460-00	SPROCKET, drive (16T)	1	
27	3Y1-17456-00	HOLDER, sprocket	1	
28	97027-06010	BOLT	2	

C5

FIG. 16 SHIFT CAM. FORK

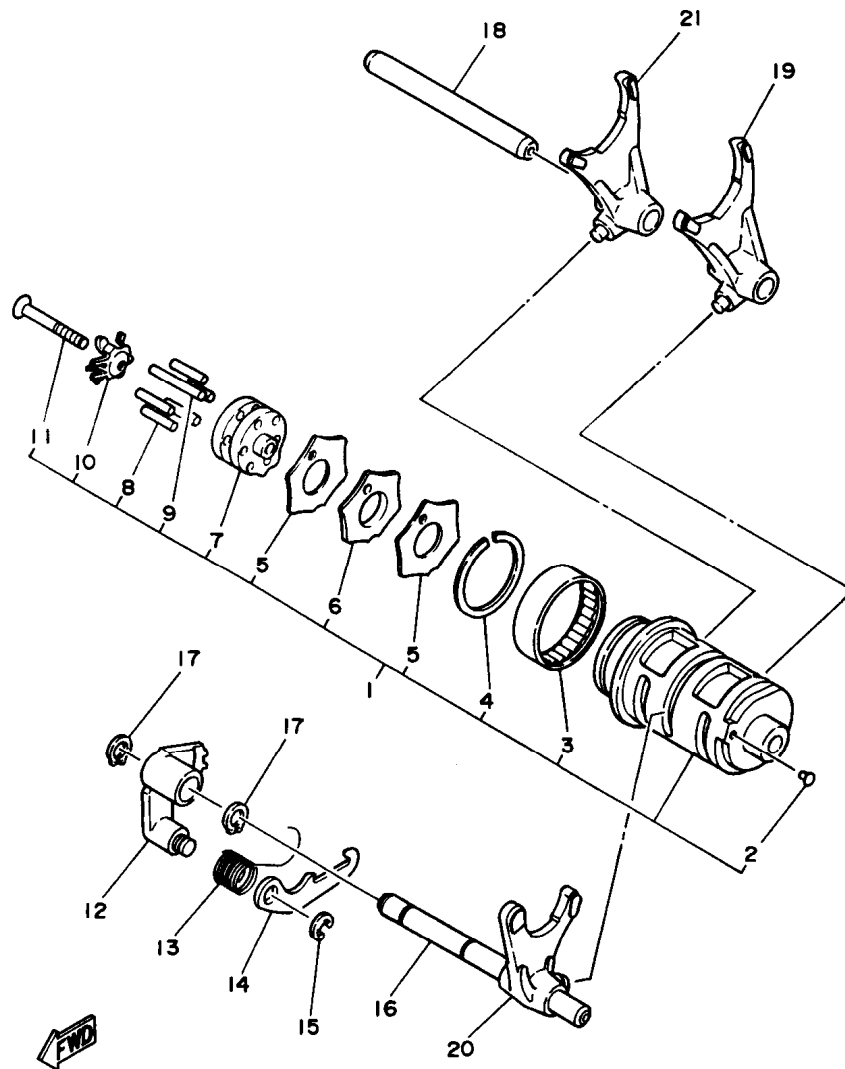

3DM010-8160

REF. NO.	PART NO.	DESCRIPTION	Q'TY	REMARKS
1	4DN-18540-00	SHIFT CAM ASSY	1	
2	136-18542-00	.POINT, neutral	1	
3	93315-23612	.BEARING, cylindrical	1	
4	93440-34025	.CIRCLIP	1	
5	3Y1-18161-00	.GUIDE, plate stopper	2	
6	3Y1-18141-00	.PLATE, stopper	1	
7	3Y1-18185-01	.SEGMENT	1	
8	93604-18100	.PIN, dowel	5	
9	93604-29151	.PIN, dowel	1	
10	2K9-18561-00	.PLATE, side 1	1	
11	98707-05035	.SCREW, flat head	1	
12	3Y1-18122-00	LEVER, shift 2	1	
13	90508-12430	SPRING, torsion	1	
14	2K7-18151-00	LEVER, shift 3	1	
15	99080-07600	CIRCLIP	1	
16	4DN-18531-00	BAR, shift fork guide 1	1	
17	99009-10400	CIRCLIP	2	
18	4DN-18535-00	BAR, shift fork guide 2	1	
19	4DN-18511-00	FORK, shift 1	1	
20	4DN-18512-00	FORK, shift 2	1	
21	4DN-18513-00	FORK, shift 3	1	

C6

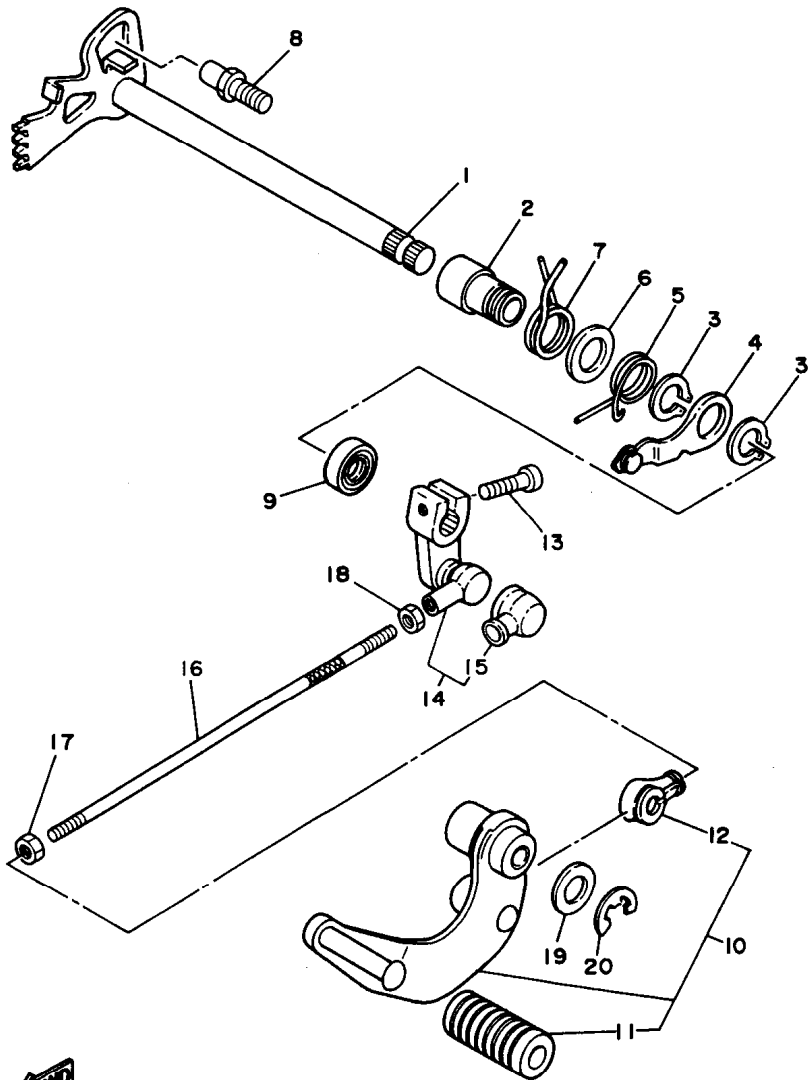

3LSI332-9170

FIG. 17 SHIFT SHAFT

REF. NO.	PART NO.	DESCRIPTION	Q'TY	REMARKS
1	2UJ-18101-01	SHIFT SHAFT ASSY	1	
2	90387-12787	COLLAR	1	
3	99009-17400	CIRCLIP	2	
4	3Y1-18140-00	STOPPER LEVER ASSY	1	
5	90508-26434	SPRING, torsion	1	
6	90201-17255	WASHER, plate	1	
7	90508-32374	SPRING, torsion	1	
8	4G0-18127-00	STOPPER, screw	1	
9	93102-12106	OIL SEAL (SD 12-22-5 HS)	1	
10	2UJ-18110-00	SHIFT PEDAL ASSY	1	
11	132-18113-01	.COVER, shift pedal	1	
12	2H9-18154-00	.COVER, dust	1	
13	97024-06020	BOLT	1	
14	2UJ-18130-00	SHIFT SHAFT ASSY	1	
15	2H9-18154-00	.COVER, dust	1	
16	2UJ-18115-02	ROD, shift	1	
17	90170-06228	NUT (COUNTER CLOCKWISE)	1	
18	95304-06700	NUT	1	
19	90201-124E4	WASHER, plate	1	
20	99009-12400	CIRCLIP	1	

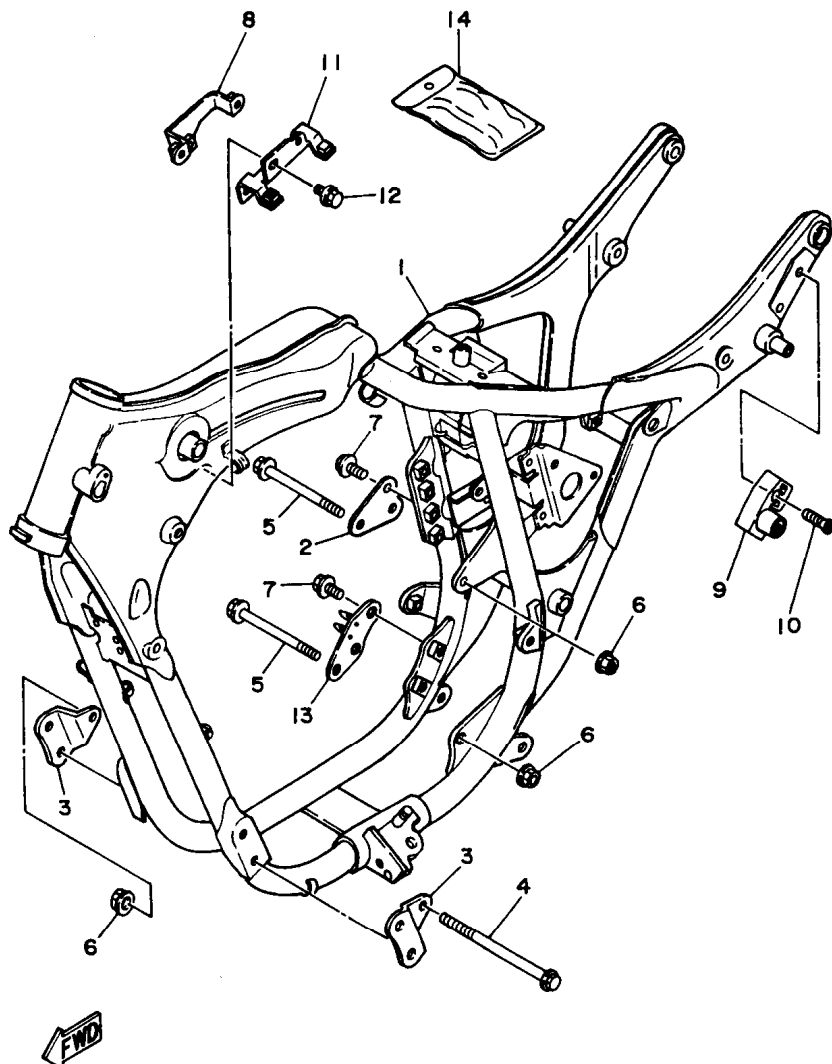

3DN171-8181

FIG. 18 FRAME

REF. NO.	PART NO.	DESCRIPTION	Q'TY	REMARKS
1	2UJ-21110-03-33	FRAME COMP.	1	UR YAMAHA BLACK FOR ITA.,CHE.
	3LS-21110-02-33	FRAME COMP.	1	UR YAMAHA BLACK FOR OTHERS
2	2UJ-21318-01	STAY, engine 5	1	UR
	4XT-F1318-00	STAY, engine 5	1	UR FOR BRAZIL
3	2UJ-21315-00	STAY, engine 2	2	UR
	4XT-F1315-00	STAY, engine 2	2	UR FOR BRAZIL
4	95814-08150	BOLT, flange	1	
5	95814-08110	BOLT, flange	2	
6	90179-08656	NUT	3	
7	95817-08016	BOLT, flange	4	
8	2UJ-21243-00	PLATE, bridge	1	UR
	4XT-F1243-00	PLATE, bridge	1	UR FOR BRAZIL
9	26H-21308-00	HELMET HANGER ASSY	1	
10	90149-06154	SCREW	1	
11	2UJ-2135Y-00	BRACKET, ignition coil	1	UR
	4XT-F135Y-00	BRACKET, ignition coil	1	UR FOR BRAZIL
12	98507-06012	BOLT, flange	1	
13	2UJ-21319-00	STAY, engine 6	1	UR
	4XT-F1319-00	STAY, engine 6	1	UR FOR BRAZIL
14	2UJ-28100-00	TOOL KIT	1	

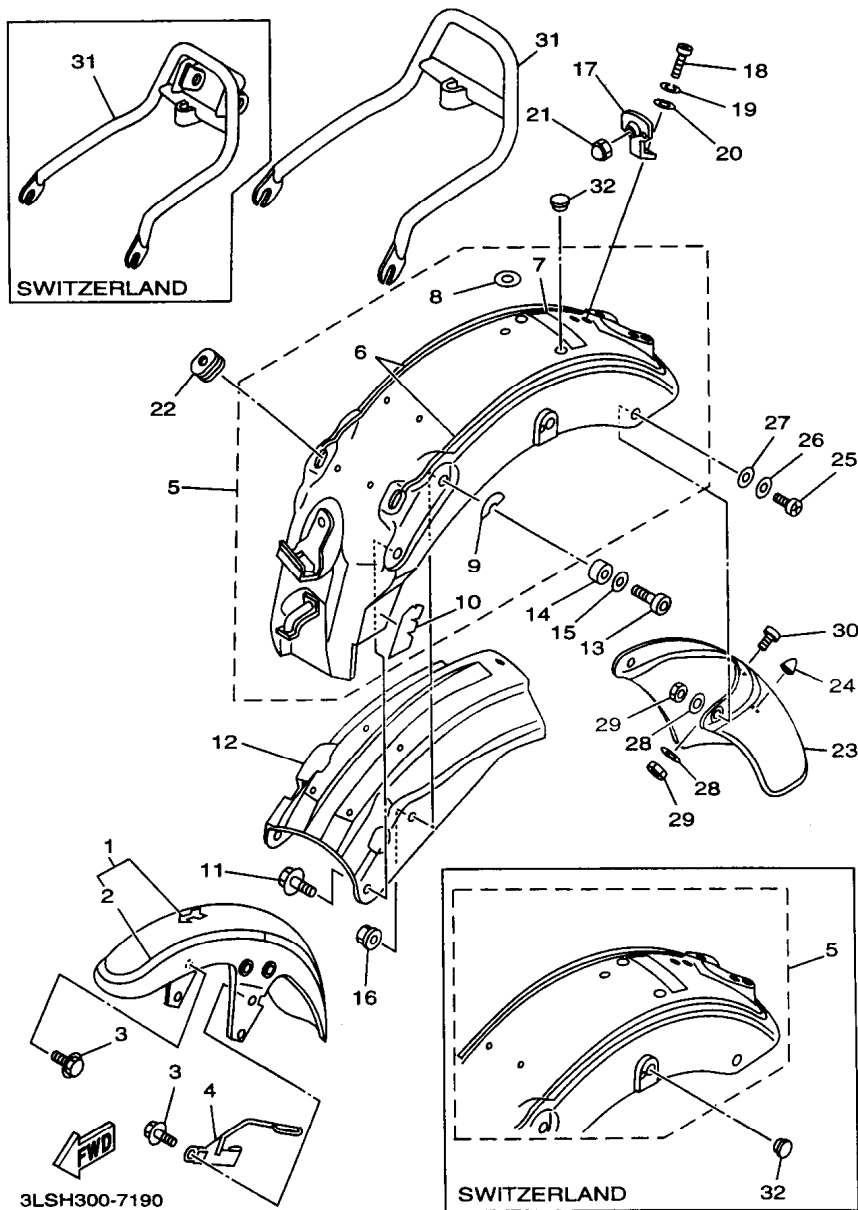

3LSH300-7190

FIG. 19 FENDER

REF. NO.	PART NO.	DESCRIPTION	Q'TY	REMARKS
1	2UJ-Y2150-00-EG	FRONT FENDER COMP.	1	UR MAPLE RED
	2UJ-Y2150-10-7M	FRONT FENDER COMP.	1	UR MIDNIGHT SILVER
2	3DM-21569-80	.GRAPHIC 1	1	UR FOR MPR
	3DM-21569-90	.GRAPHIC 1	1	UR FOR MDS
3	95024-08012	BOLT	4	
4	3DM-21597-00	HOLDER, wire 1	1	
5	3LS-Y2161-80-0X	REAR FENDER COMP.	1	UR MAPLE RED/SILKY GOLD
	3LS-Y2161-90-1X	REAR FENDER COMP.	1	UR MIDNIGHT SILVER/ BLACK 2
6	3DM-2165A-81	.GRAPHIC, rear fender	1	UR FOR MPR
	3DM-2165A-80	.GRAPHIC, rear fender	1	UR FOR MDS
7	99237-00080	.EMBLEM, yamaha	1	
8	2UJ-21735-00	.SEAL 2	1	
9	3DM-2173N-00	.SEAL 4	2	
10	2UJ-2173M-01	.SEAL 3	1	
11	95817-10020	BOLT, flange	2	
12	2UJ-21670-00	REINF. COMP.	1	
13	92014-10050	BOLT, button head	2	
14	90387-100E2	COLLAR	2	
15	92990-10200	WASHER, plane	2	
16	95707-10500	NUT, flange	2	
17	2UJ-21641-00	BRACKET, reflector	1	
18	98507-05010	SCREW, pan head	1	
19	92907-05100	WASHER, spring	1	
20	92907-05600	WASHER, plate	1	
21	95307-05800	NUT, cap	1	
22	90480-01502	GROMMET	2	
23	3LS-21621-00	FLAP	1	
24	4G0-21639-00	DAMPER 2	1	

C9

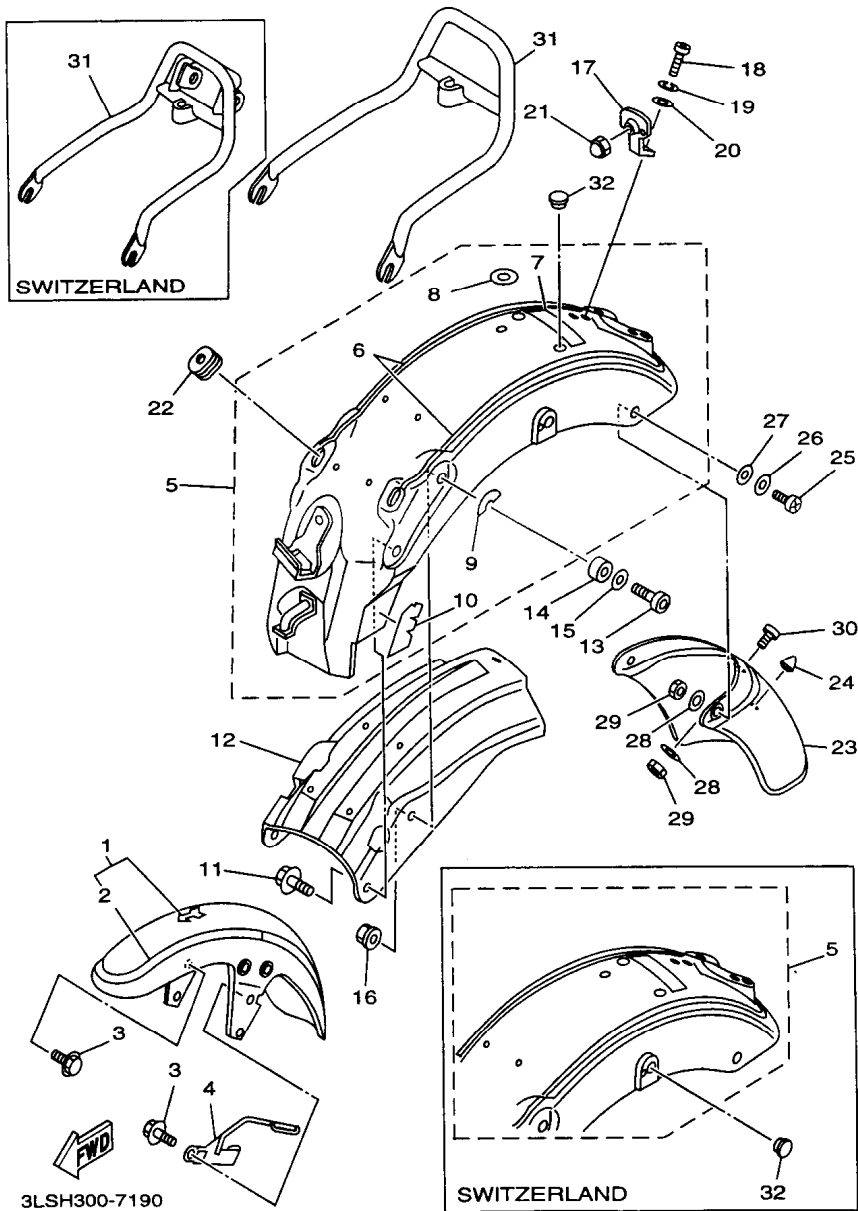

3LSH300-7190

FIG. 19 FENDER

REF. NO.	PART NO.	DESCRIPTION	Q'TY	REMARKS
25	98517-06012	SCREW, pan head	2	
26	92907-06600	WASHER, plate	2	
27	90202-05187	WASHER, plate	2	
28	92907-06200	WASHER	3	
29	95317-06600	NUT	3	
30	98904-06014	SCREW, bind	1	
31	3LS-21640-00	REAR STAY COMP.	1	UR
	3LU-21640-00	REAR STAY COMP.	1	UR FOR SWITZERLAND
32	1J3-24742-00	GROMMET	2	

C10

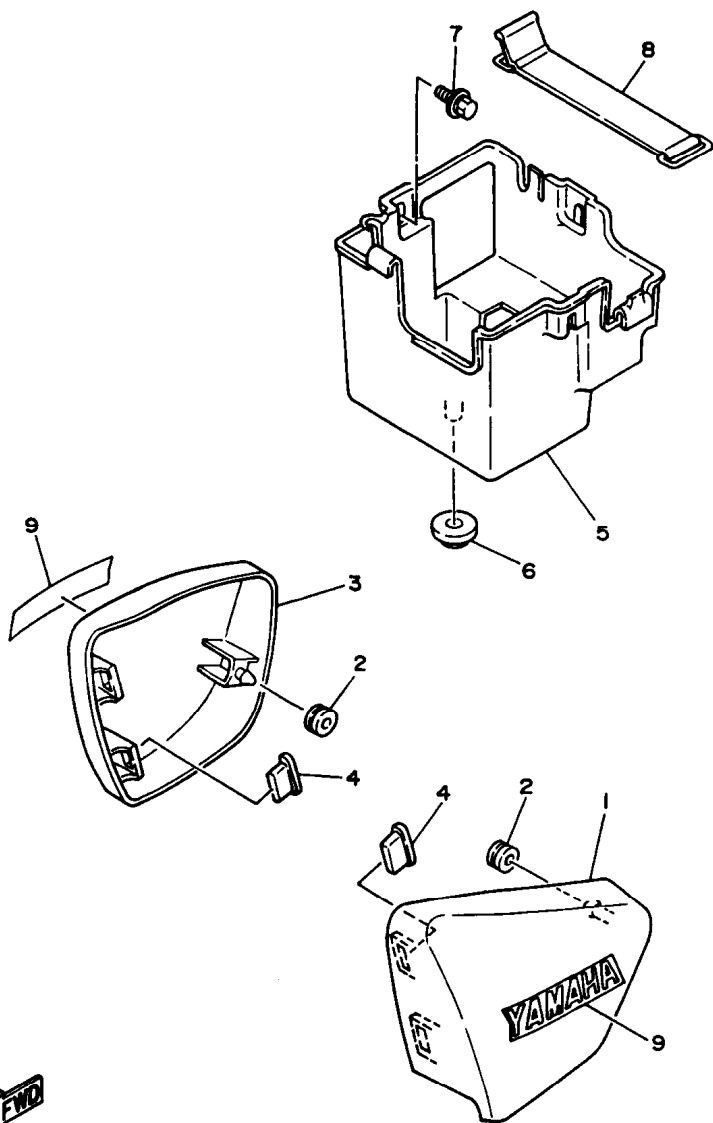

FIG. 20 SIDE COVER

REF. NO.	PART NO.	DESCRIPTION	Q'TY	REMARKS
1	2UJ-21711-00-EG	COVER, side 1	1	UR MAPLE RED
	2UJ-21711-00-7M	COVER, side 1	1	UR MIDNIGHT SILVER
	2UJ-21711-00-4B	COVER, side 1 (FOR BRAZIL)	1	UR BLACK 2
2	90480-13428	GROMMET	2	
3	2UJ-21721-00-EG	COVER, side 2	1	UR MAPLE RED
	2UJ-21721-00-7M	COVER, side 2	1	UR MIDNIGHT SILVER
	2UJ-21721-00-4B	COVER, side 2 (FOR BRAZIL)	1	UR BLACK 2
4	2N4-21717-00	DAMPER, side cover	4	
5	2UJ-2177G-00	BOX, battery	1	
6	90480-22362	GROMMET	1	
7	90119-06108	BOLT, with washer	2	
8	26H-82131-00	BAND, battery	1	
9	99235-00080	EMBLEM, yamaha	2	UR FOR MPR
	99234-00080	EMBLEM, yamaha	2	UR FOR MDS
	99236-00080	EMBLEM, yamaha (FOR BRAZIL)	2	UR FOR BL2



3DMO10-8200

C11

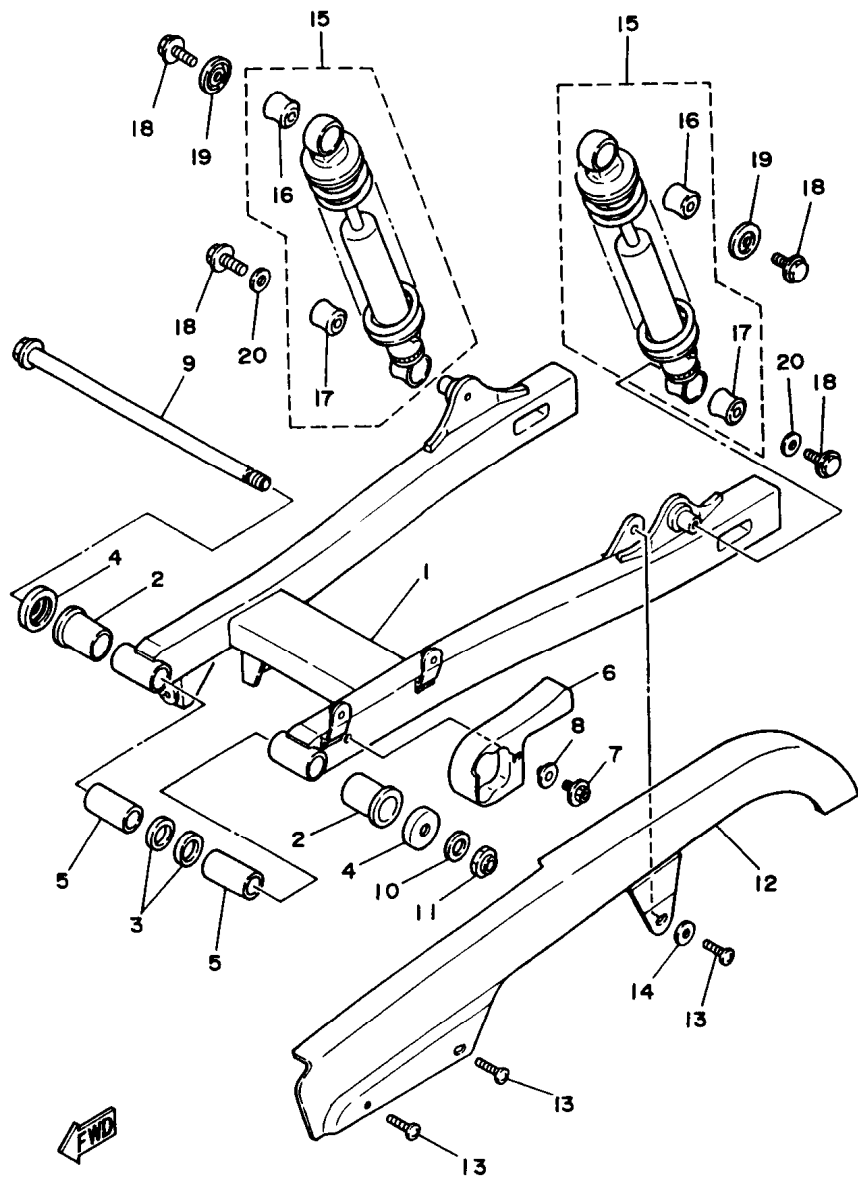

2UJ110-8210

FIG. 21 REAR ARM

REF. NO.	PART NO.	DESCRIPTION	Q'TY	REMARKS
1	3LS-22110-00-33	REAR ARM COMP.	1	YAMAHA BLACK
2	90386-18163	BUSH	2	
3	93109-18020	OIL SEAL	2	
4	55K-22129-00	COVER, thrust 2	2	
5	90380-12121	BUSH, solid	2	
6	55K-22151-01	SEAL, guard	1	
7	90119-05062	BOLT, with washer	1	
8	90209-06223	WASHER	1	
9	2UJ-22141-01	SHAFT, pivot	1	
10	92903-12200	WASHER, plain	1	
11	90185-12164	NUT, self-locking	1	
12	3LS-22311-00	CASE, chain	1	
13	98904-06012	SCREW, bind	3	
14	90201-065F3	WASHER, plate	1	
15	3DM-22210-00	SHOCK ABSORBER ASSY, rear	2	
16	447-22217-21	.DAMPER, shock absorber lower	1	
17	447-22216-20	.BUSH, rear shock absorber	1	
18	95024-08012	BOLT, flange	4	
19	1UJ-22243-00	WASHER 1	2	
20	90201-087G2	WASHER, plate	2	

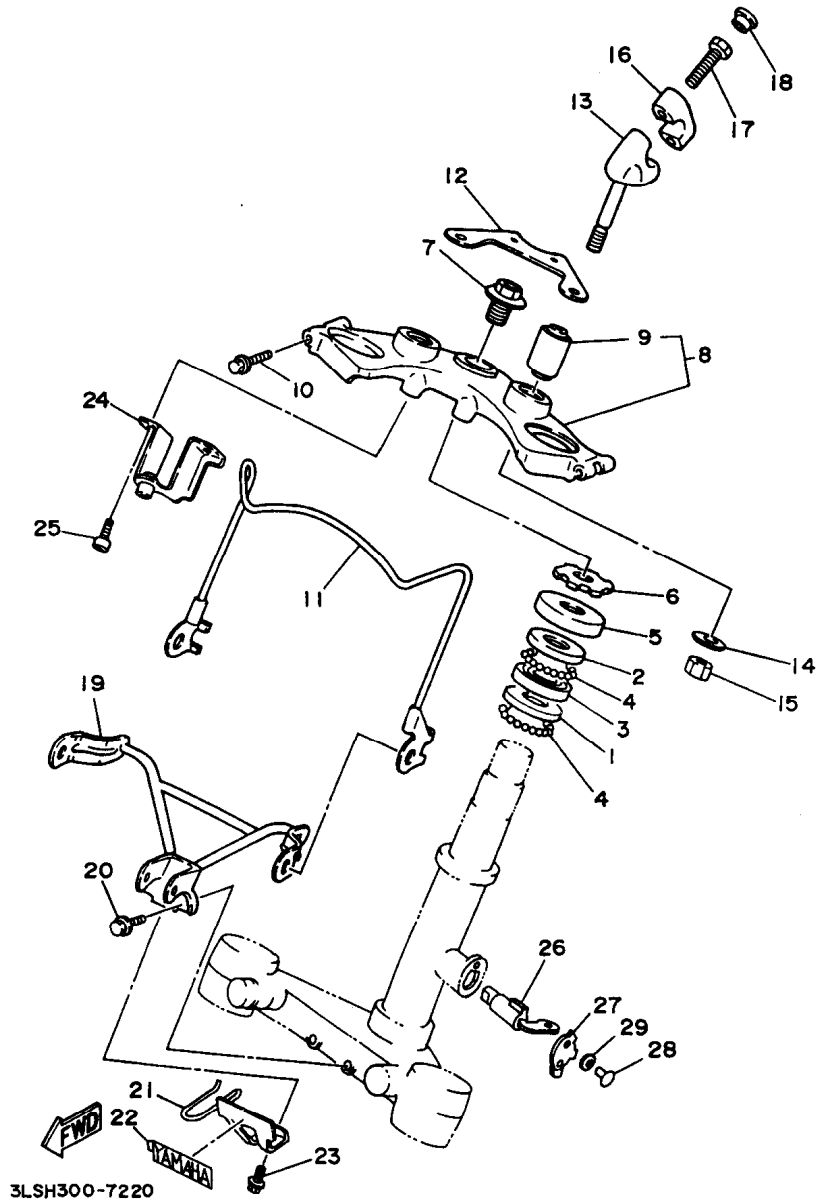

FIG. 22 STEERING

REF. NO.	PART NO.	DESCRIPTION	Q'TY	REMARKS
1	156-23412-00	RACE, ball 2	1	
2	183-23411-00	RACE, ball 1	1	
3	183-23412-00	RACE, ball 2	1	
4	93501-04011	BALL	38	
5	136-23415-00	COVER, ball race 1	1	
6	90179-25033	NUT	1	
7	90105-14102	BOLT, washer based	1	
8	2UJ-W2341-00-35	CROWN, handle	1	SILVER
9	5A8-23434-01	.HOLDER, damper	2	
10	95024-08040	BOLT, flange	2	
11	3DM-23164-00	STAY, light guard	1	UR
	4XT-F3164-00	STAY, light guard	1	UR FOR BRAZIL
12	3DM-2317F-00	STAY 2	1	UR
	4XT-F317F-00	STAY 2	1	UR FOR BRAZIL
13	42X-23442-00-38	HOLDER, handle lower	2	CLEAR (WITH BUFF)
14	90201-105A2	WASHER, plate	2	
15	95617-10100	NUT, u	2	
16	4H7-23441-00-38	HOLDER, handle upper	2	CLEAR (WITH BUFF)
17	91314-08025	BOLT	4	
18	90338-08163	PLUG	4	
19	2UJ-23174-00	STAY, headlight	1	
20	95024-06016	BOLT	2	
21	2UJ-2317M-00	STAY 3	1	UR
	4XT-F317M-00	STAY 3	1	UR FOR BRAZIL
22	3WF-2153E-40	EMBLEM, yamaha	1	
23	95024-06012	BOLT	1	
24	2UJ-2317E-00	STAY	1	
25	91317-06016	BOLT	2	

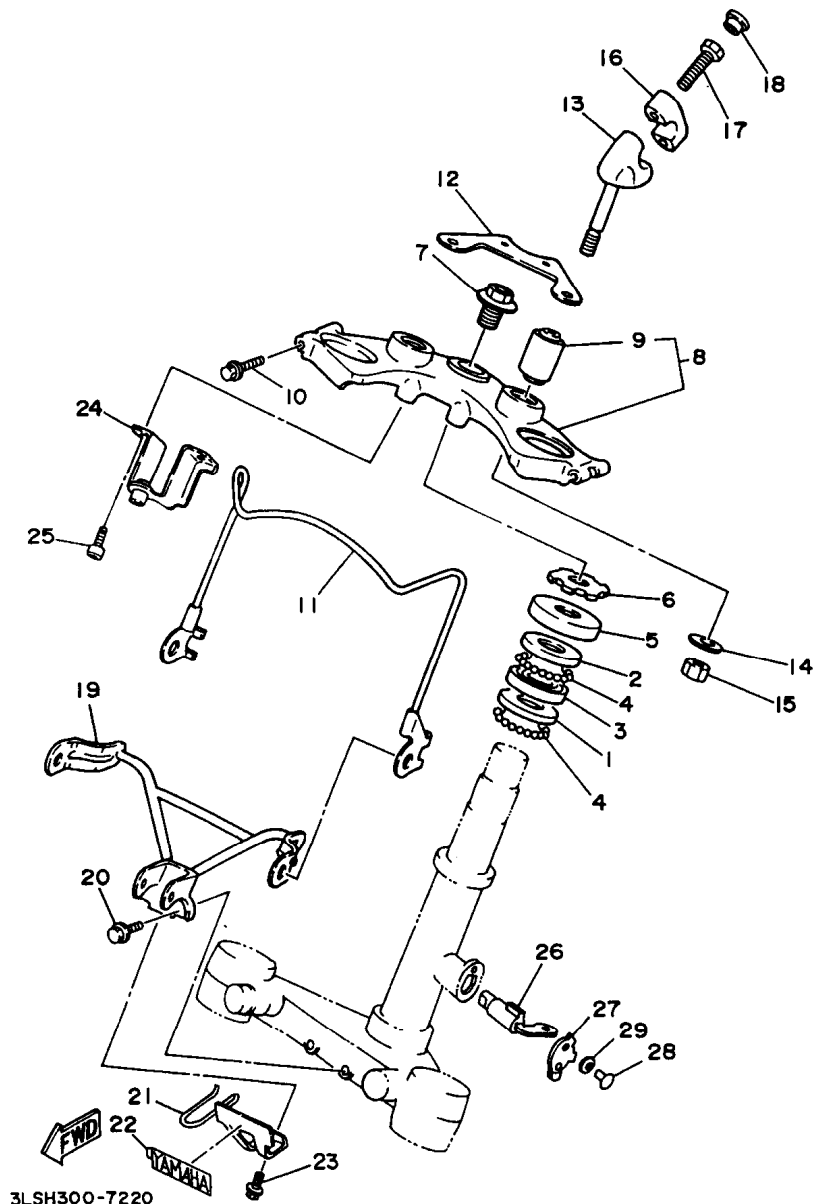
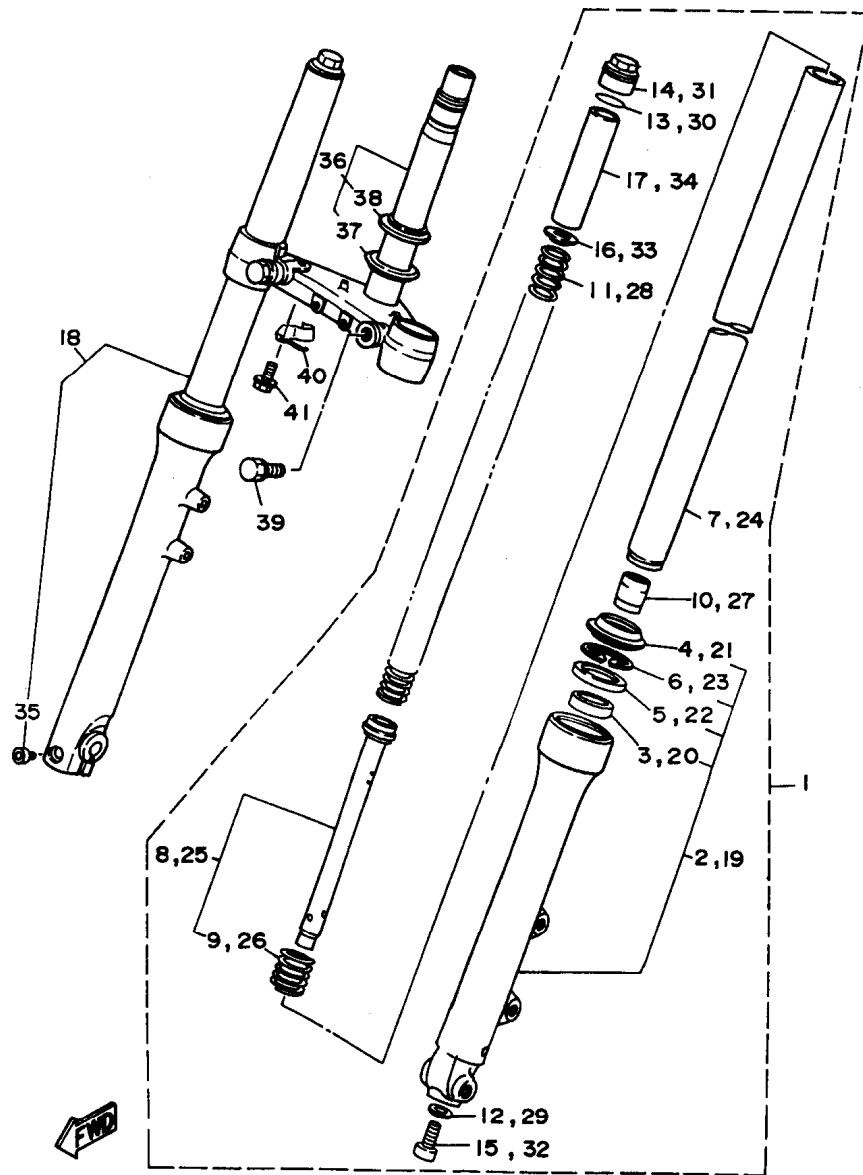

FIG. 22 STEERING

REF. NO.	PART NO.	DESCRIPTION	Q'TY	REMARKS
26	*	STEERING LOCK ASSY (LM)	1	UR
	4XT-F3480-00	STEERING LOCK ASSY	1	UR FOR BRAZIL
27	134-23484-10	CAP, handle lock	1	UR
	4XT-F3484-00	CAP, handle lock	1	UR FOR BRAZIL
28	90269-04003	RIVET	1	
29	90208-04029	WASHER, conical spring	1	



3LS7351-5230

FIG. 23 FRONT FORK

REF. NO.	PART NO.	DESCRIPTION	Q'TY	REMARKS
1	2UJ-23102-10	FRONT FORK ASSY (L.H)	1	
2	2UJ-23126-10	.TUBE, outer 1	1	
3	51Y-23125-00	..METAL, slide 1	1	
4	51Y-23144-00	..SEAL, dust	1	
5	51Y-23145-00	..OIL SEAL	1	
6	22W-23153-L0	..RING, snap	1	
7	2UJ-23110-00	.INNER TUBE COMP.1	1	
8	2UJ-23170-00	.CYLINDER COMP., front fork	1	
9	509-23151-L0	..SPRING, rebound	1	
10	39K-23173-00	.SPINDLE, taper	1	
11	2UJ-23141-00	.SPRING, front fork	1	
12	509-23158-L0	.GASKET	1	
13	3J2-23114-00	.O-RING	1	
14	2JN-23111-00	.BOLT, cap	1	
15	278-23181-50	.BOLT, hexagon socket head	1	
16	3DM-23149-10	.WASHER, spring upper	1	
17	58T-23118-L0	.SPACER	1	
18	2UJ-23103-10	FRONT FORK ASSY (R.H)	1	
19	2UJ-23136-10	.TUBE, outer 2	1	
20	51Y-23125-00	..METAL, slide 1	1	
21	51Y-23144-00	..SEAL, dust	1	
22	51Y-23145-00	..OIL SEAL	1	
23	22W-23153-L0	..RING, snap	1	
24	2UJ-23110-00	.INNER TUBE COMP. 1	1	
25	2UJ-23170-00	.CYLINDER COMP., front fork	1	
26	509-23151-L0	..SPRING, rebound	1	
27	39K-23173-00	.SPINDLE, taper	1	
28	2UJ-23141-00	.SPRING, front fork	1	

C15

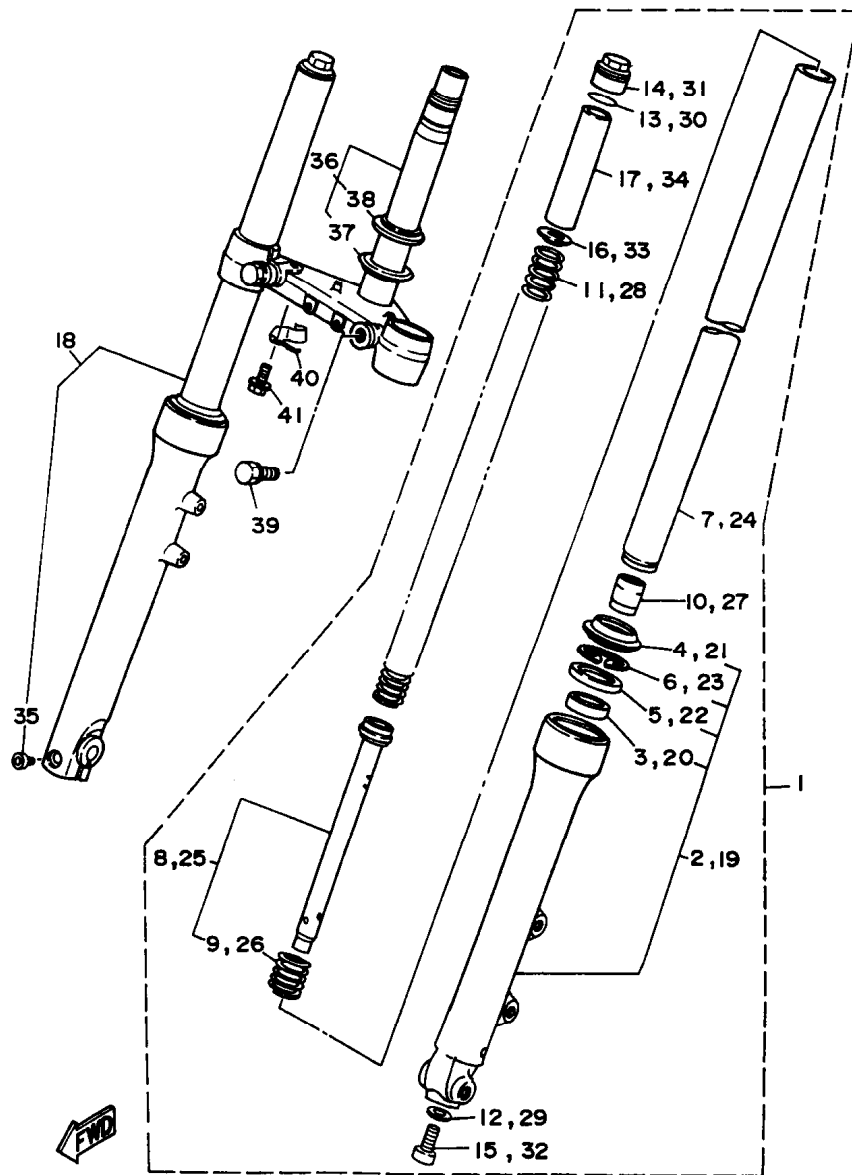

3LS7351-5230

FIG. 23 FRONT FORK

REF. NO.	PART NO.	DESCRIPTION	Q'TY	REMARKS
29	509-23158-L0	.GASKET	1	
30	3J2-23114-00	.O-RING	1	
31	2JN-23111-00	.BOLT, cap	1	
32	278-23181-50	.BOLT, hexagon socket head	1	
33	3DM-23149-10	.WASHER, spring upper	1	
34	58T-23118-L0	.SPACER	1	
35	91311-08035	.BOLT	1	
36	3LS-23340-00	UNDER BRACKET COMP.	1	
37	164-23462-00	.SEAL, steering	1	
38	156-23411-00	.RACE, ball 1	1	
39	2UJ-23346-00	BOLT 1	2	
40	3DM-25886-10	HOLDER, brake hose	1	UR
	4XT-F5886-00	HOLDER, brake hose	1	UR FOR BRAZIL
41	98507-06010	BOLT, flange	1	

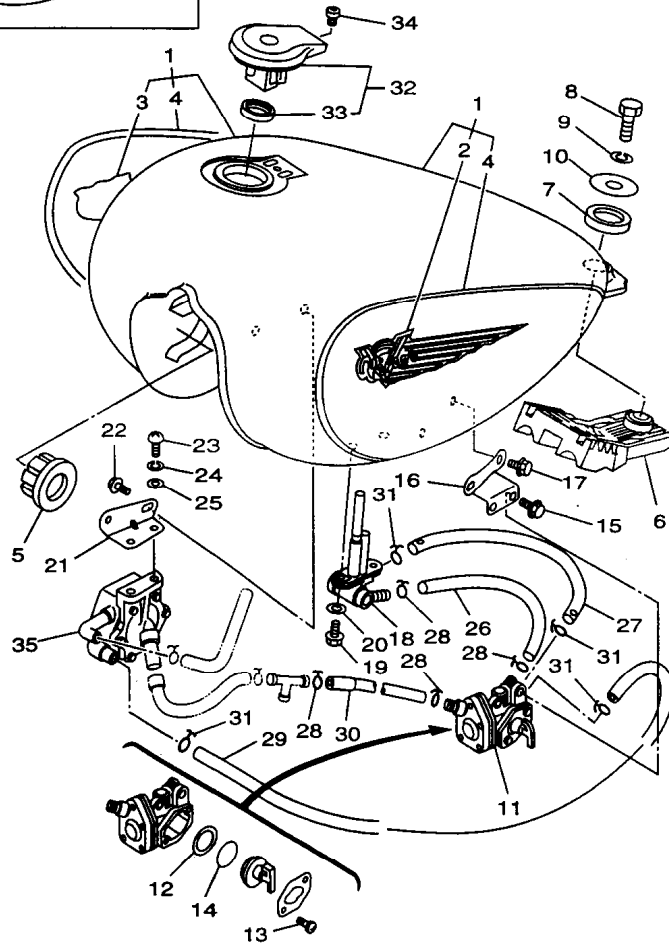
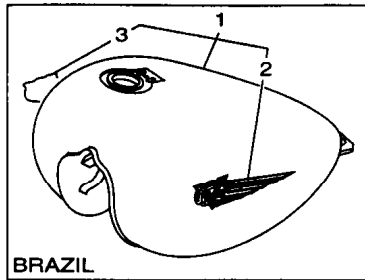



3LSH300-7240

FIG. 24 FUEL TANK

REF. NO.	PART NO.	DESCRIPTION	Q'TY	REMARKS
1	3DM-24110-00-09	FUEL TANK COMP.	1	UR MAPLE RED/SILKY GOLD
	3DM-24110-00-X7	FUEL TANK COMP.	1	UR MIDNIGHT SILVER/ BLACK 2
	2UJ-24110-00-W3	FUEL TANK COMP. (FOR BRAZIL)	1	UR BLACK 2
2	3LW-24161-40	.EMBLEM 1	2	UR FOR MPR
	3LW-24161-70	.EMBLEM 1	2	UR FOR MDS
	3LW-24161-00	.EMBLEM 1 (FOR BRAZIL)	1	UR BL2
3	3LW-24162-40	.EMBLEM 2	1	UR FOR MPR
	3LW-24162-70	.EMBLEM 2	1	UR FOR MDS
	3LW-24162-00	.EMBLEM 2 (FOR BRAZIL)	1	UR BL2
4	3DM-24240-80	.GRAPHIC SET, fuel tank	1	UR FOR MPR
	3DM-24240-B0	.GRAPHIC SET, fuel tank	1	UR FOR MDS
5	4H7-24181-00	DAMPER, locating 1	2	
6	2UJ-24182-00	DAMPER, locating 2	1	
7	42X-24183-00	DAMPER, locating 3	1	
8	97007-08035	BOLT	1	
9	92907-08100	WASHER, spring	1	
10	90201-08569	WASHER, plate	1	
11	2UJ-24500-00	FUEL COCK ASSY 1	1	
12	3H3-24523-00	.VALVE	1	
13	98503-03008	.SCREW, pan head	2	
14	1JK-24534-00	.SEAL, cock	1	
15	95024-06010	BOLT, flange	2	
16	2UJ-24544-01	BRACKET, fuel cock	1	
17	95024-06010	BOLT, flange	2	
18	2UJ-24560-00	FILTER ASSY	1	
19	90149-06011	SCREW	2	
20	90202-05187	WASHER, plate	2	
21	2UJ-24491-01	BRACKET, fuel pump	1	UR

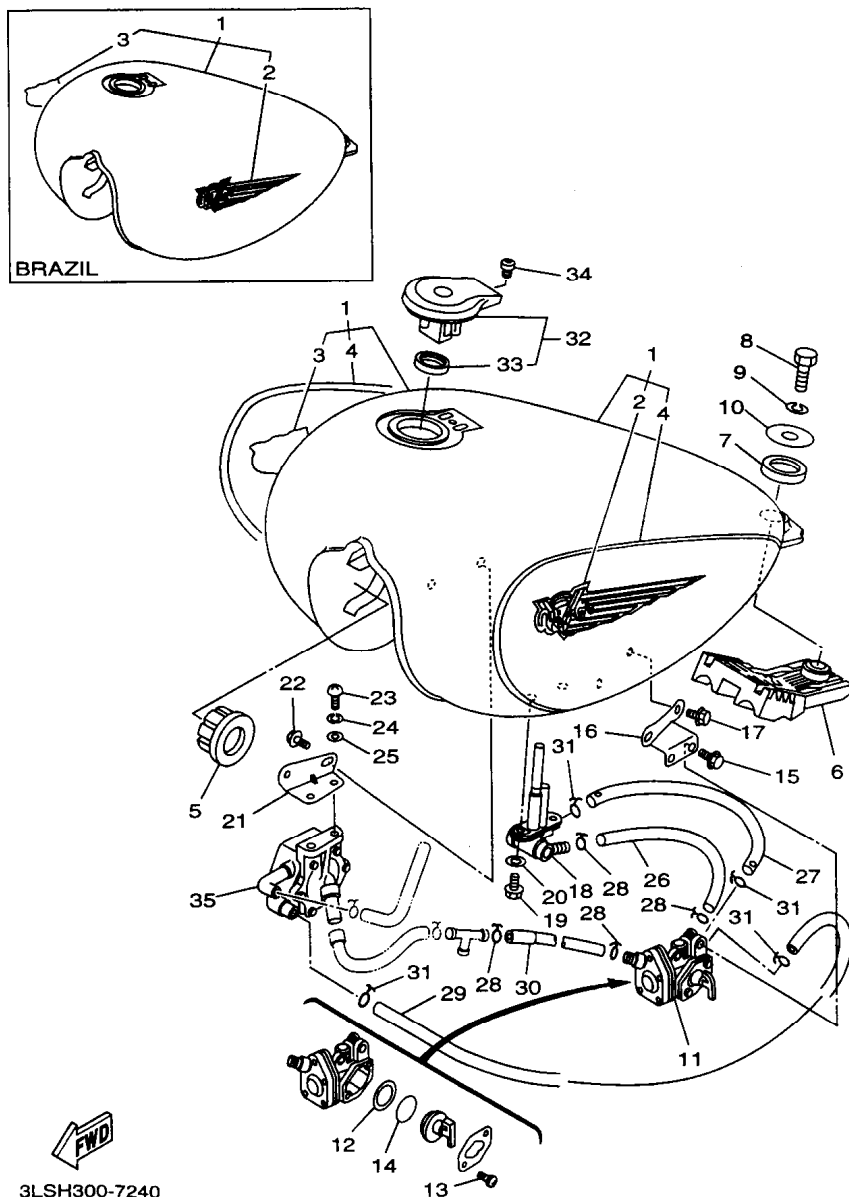
D3



3LSH300-7240

FIG. 24 FUEL TANK

REF. NO.	PART NO.	DESCRIPTION	Q'TY	REMARKS
21	4XT-F4491-00	BRACKET, fuel pump	1	UR FOR BRAZIL
22	95024-06010	BOLT, flange	2	
23	98507-06012	SCREW, pan head	2	
24	92907-06100	WASHER, spring	2	
25	92907-06600	WASHER, plate	2	
26	90445-11501	HOSE	1	
27	90445-11754	HOSE	1	
28	90467-10008	CLIP	4	
29	2UJ-24312-01	PIPE 2	1	
30	2UJ-24313-00	PIPE 3	1	
31	90467-10008	CLIP	4	
32	4X7-24602-04	CAP ASSY	1	
33	4X7-24612-00	.GASKET, cap	1	
34	91317-05010	BOLT	1	
35	3DM-13910-00	FUEL PUMP ASSY	1	

FIG. 25 SEAT

REF. NO.	PART NO.	DESCRIPTION	Q'TY	REMARKS
1	3DM-24710-10	SINGLE SEAT ASSY	1	
2	3DM-24731-10	.COVER, seat	1	
3	18A-24724-00	.DAMPER, seat	4	
4	95807-06016	BOLT, flange	2	
5	3LS-24750-10	TANDEM SEAT ASSY	1	
6	3DM-24751-10	.COVER, tandem seat	1	
7	509-24724-00	.DAMPER, seat	4	
8	2UJ-2471A-00	.STAY, seat	1	
9	95707-06500	.NUT, flange	2	
10	92014-08035	BOLT, button head	1	UR
	95024-08025	BOLT, flange	1	UR FOR BRAZIL
11	2UJ-2475H-00	BRACKET, seat lever 1	1	
12	95027-06012	BOLT	2	

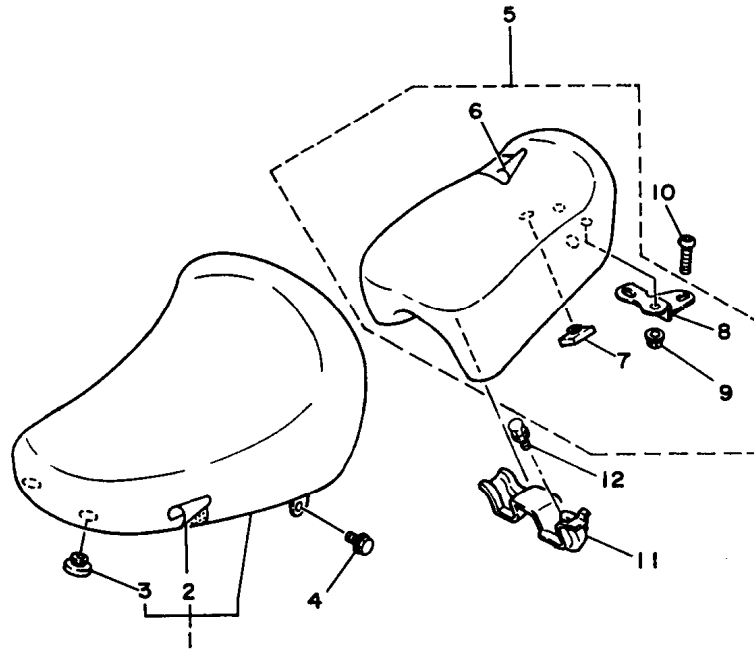



3LS1332-9250

D5

FIG. 26 FRONT WHEEL

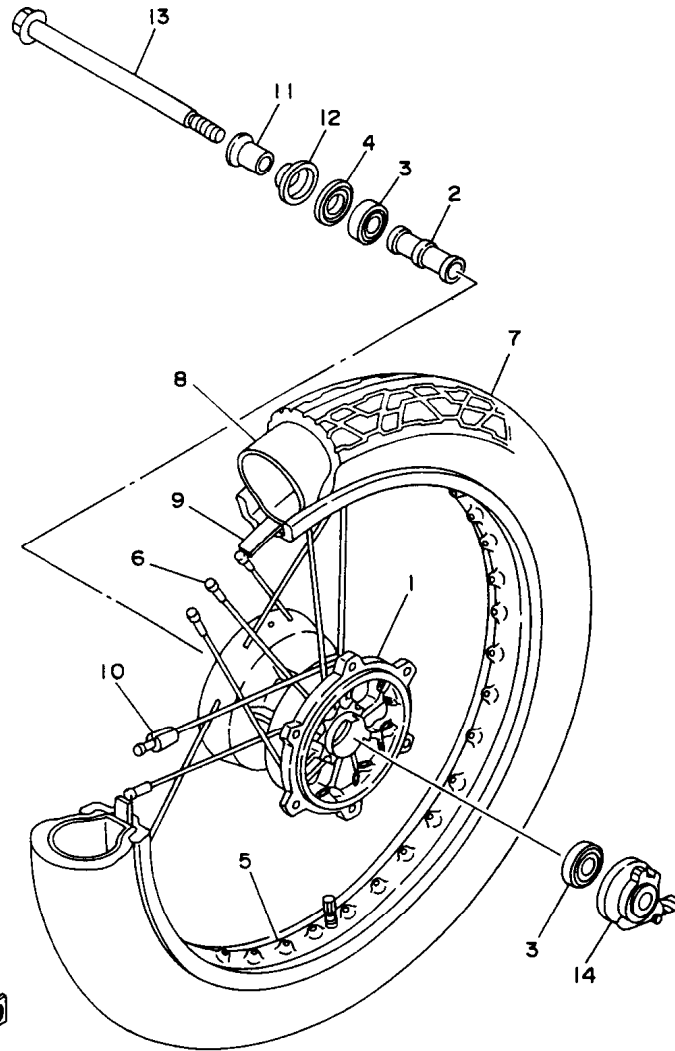
REF. NO.	PART NO.	DESCRIPTION	Q'TY	REMARKS
1	4DN-25111-20-35	HUB, front	1	SILVER
2	90560-15240	SPACER	1	
3	93306-20209	BEARING (B6202)	2	
4	93102-20281	OIL SEAL	1	
5	94416-18523	RIM (1.60-18)	1	
6	3DM-25104-00	SPOKE SET, front	1	
7	94130-185T4	TIRE (3.00-18-4PR NF27,47p)	1	INOUE
8	94227-18195	TUBE (2.75-18)	1	DUNLOP
9	94345-18081	BAND, rim (4.50-18)	1	INOUE
10	156-25398-00	BALANCER, wheel	1	UN
11	90387-15600	COLLAR	1	
12	322-25118-00	COVER, hub dust	1	
13	10W-25381-00	AXLE, wheel	1	
14	4DN-25190-01	GEAR UNIT ASSY	1	



4DN2010-3260

D6

FIG. 27 FRONT BRAKE CALIPER

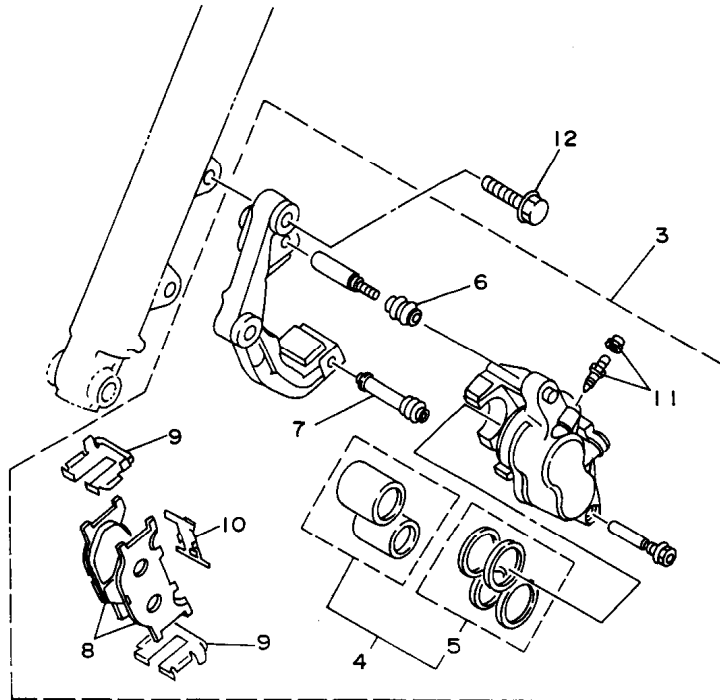

REF. NO.	PART NO.	DESCRIPTION	Q'TY	REMARKS
1	3LP-2582T-00	DISC, brake (LEFT)	1	
2	90109-081F0	BOLT	6	
3	4HM-2580T-00	CALIPER ASSY (RIGHT)	1	
4	4FU-W0057-50	.PISTON ASSY, caliper	1	
5	4FU-W0047-50	..CALIPER SEAL KIT	1	
6	5R2-25937-00	.BOOT 2	1	
7	3YX-25937-00	.BOOT	1	
8	4HM-W0045-00	.BRAKE PAD KIT	1	
9	4BP-25919-00	.SUPPORT, pad	2	
10	3YX-25929-00	.SPRING	1	
11	51L-W0048-00	.BLEED SCREW KIT	1	
12	90105-10638	BOLT, washer based	2	

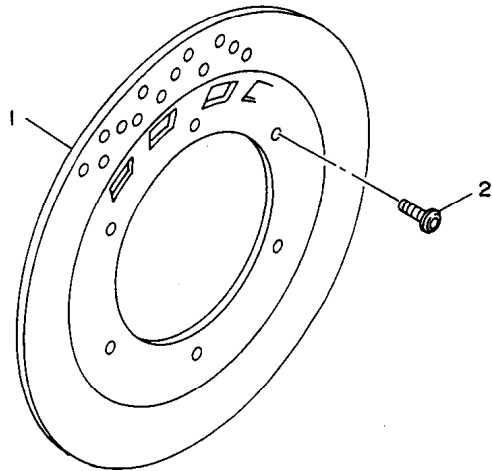

 3LP9010-4290

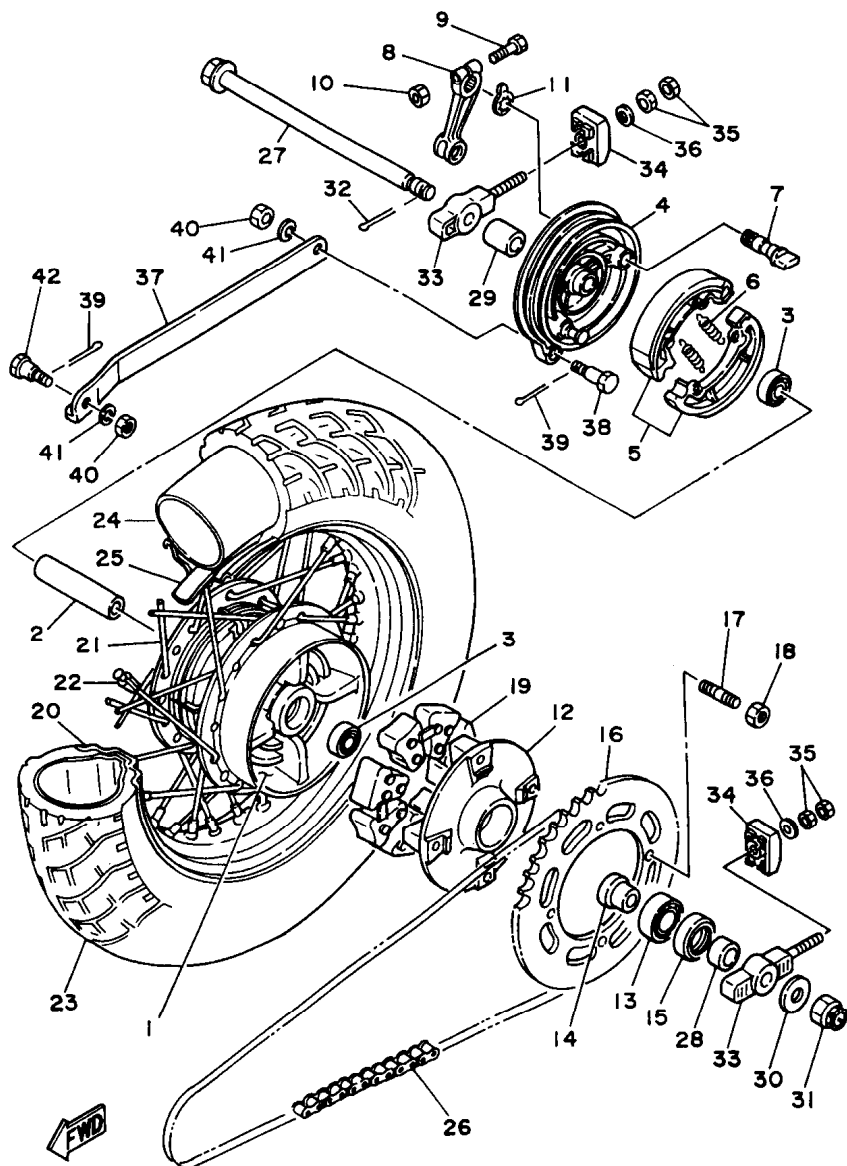

3LV7700-5280

FIG. 28 REAR WHEEL

REF. NO.	PART NO.	DESCRIPTION	Q'TY	REMARKS
1	2UJ-25311-10	HUB, rear	1	
2	2UJ-25317-00	SPACER, bearing	1	
3	93306-20226	BEARING	2	
4	2RH-25321-10	PLATE, brake shoe	1	
5	3LS-W2536-00	BRAKE SHOE SET	1	
6	90506-15260	SPRING, tension	2	
7	2RH-25351-00	CAMSHAFT	1	
8	5H0-25355-00	LEVER, camshaft	1	
9	90101-06765	BOLT	1	
10	95304-06600	NUT	1	
11	3Y6-2533A-01	PLATE, indicator	1	
12	5Y1-25366-10	CLUTCH, hub	1	
13	93306-30416	BEARING (B6304RS)	1	
14	2UJ-25377-00	COLLAR, wheel	1	UR
	4XT-F5377-00	COLLAR, wheel	1	UR FOR BRAZIL
15	93106-30029	OIL SEAL	1	
16	4DN-25445-20	SPROCKET, driven (45T)	1	
17	90116-10485	BOLT, stud	4	
18	95604-10200	NUT	4	
19	5Y1-25364-00	DAMPER	4	
20	94427-15476	RIM	1	
21	2UJ-25304-00	SPOKE SET, rear	1	
22	156-25398-00	BALANCER, wheel	1	UN
23	94113-154W1	TIRE (130/90-15 M/C)	1	INOUE
24	94213-15265	TUBE (130/90-15, 140/80-15)	1	INOUE
25	94313-15154	BAND, rim	1	INOUE
26	94581-18114	CHAIN (DID520V6 114LE)	1	
27	2UJ-25381-00	AXLE, wheel	1	

D8

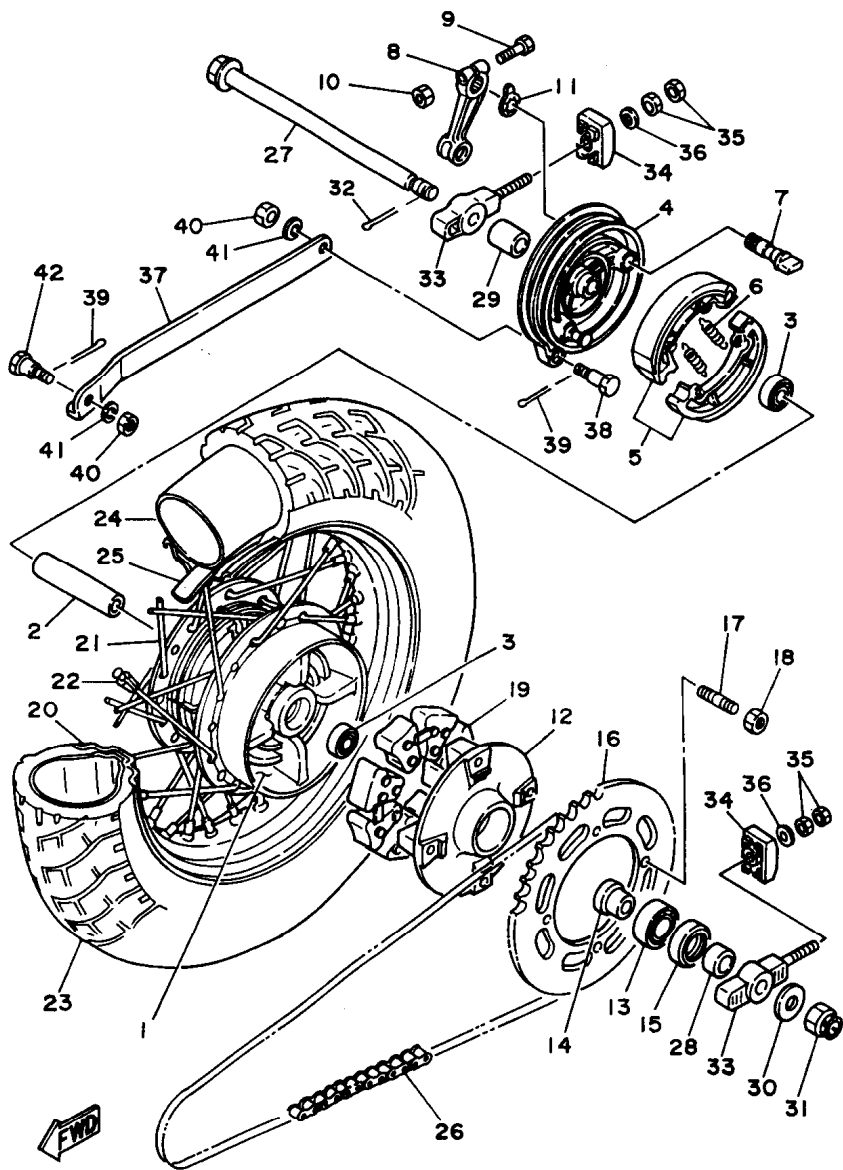

3LV7700-5280

FIG. 28 REAR WHEEL

REF. NO.	PART NO.	DESCRIPTION	Q'TY	REMARKS
28	2UJ-25383-00	COLLAR, wheel	1	
29	90387-153U1	COLLAR	1	
30	92903-14200	WASHER, plain	1	
31	90171-14056	NUT, castle	1	
32	91401-30030	PIN, cotter	1	
33	2UJ-25388-00	PULLER, chain 1	2	
34	55K-2539F-00	PLATE 1	2	
35	95304-08600	NUT	4	
36	92990-08600	WASHER, plate	2	
37	2UJ-25371-00	BAR, tension	1	
38	90109-081G5	BOLT	1	
39	91401-20015	PIN, cotter	2	
40	95304-08700	NUT	2	
41	92990-08100	WASHER, spring	2	
42	90109-081G6	BOLT	1	

D9

FIG. 29 STEERING HANDLE. CABLE

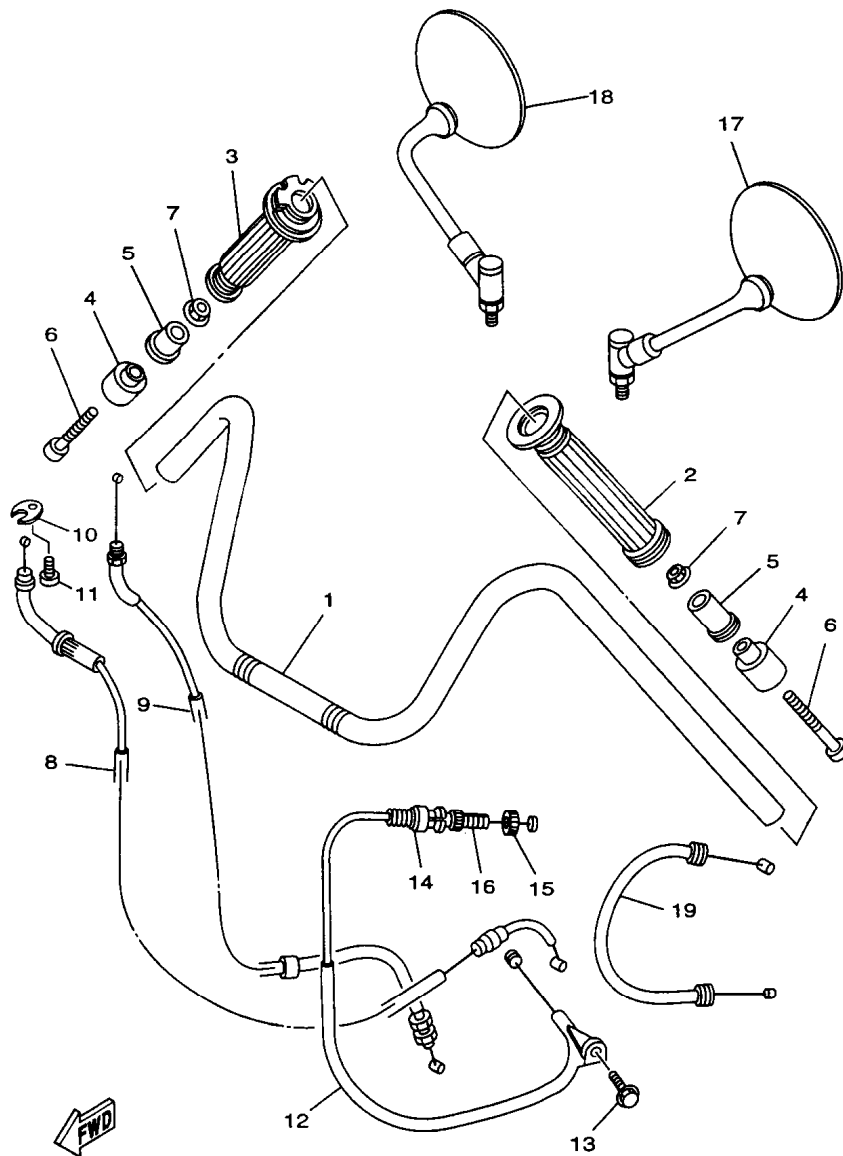

3LSH300-7290

REF. NO.	PART NO.	DESCRIPTION	Q'TY	REMARKS
1	2UJ-26111-01	HANDLEBAR	1	
2	21A-26241-00	GRIP (LEFT)	1	
3	2UJ-26240-00	GRIP ASSY	1	
4	42N-26246-00	END, grip	2	
5	1FW-2622F-01	DAMPER, locating 1	2	
6	91314-06075	BOLT	2	
7	90179-06403	NUT	2	
8	2UJ-26311-01	CABLE, throttle 1	1	
9	2UJ-26312-01	CABLE, throttle 2	1	
10	5H0-26393-00	HOLDER	1	
11	98507-05008	SCREW, pan head	1	
12	2UJ-26335-01	CABLE, clutch	1	
13	95027-06012	BOLT, flange	1	
14	1E6-26342-00	BOOT, cable	1	
15	90179-08148	NUT	1	
16	90123-08046	BOLT	1	
17	1J7-26290-F0	BACK MIRROR ASSY (L.H)	1	
18	1J7-26290-G0	BACK MIRROR ASSY (R.H)	1	
19	2UJ-26331-01	CABLE, starter 1	1	

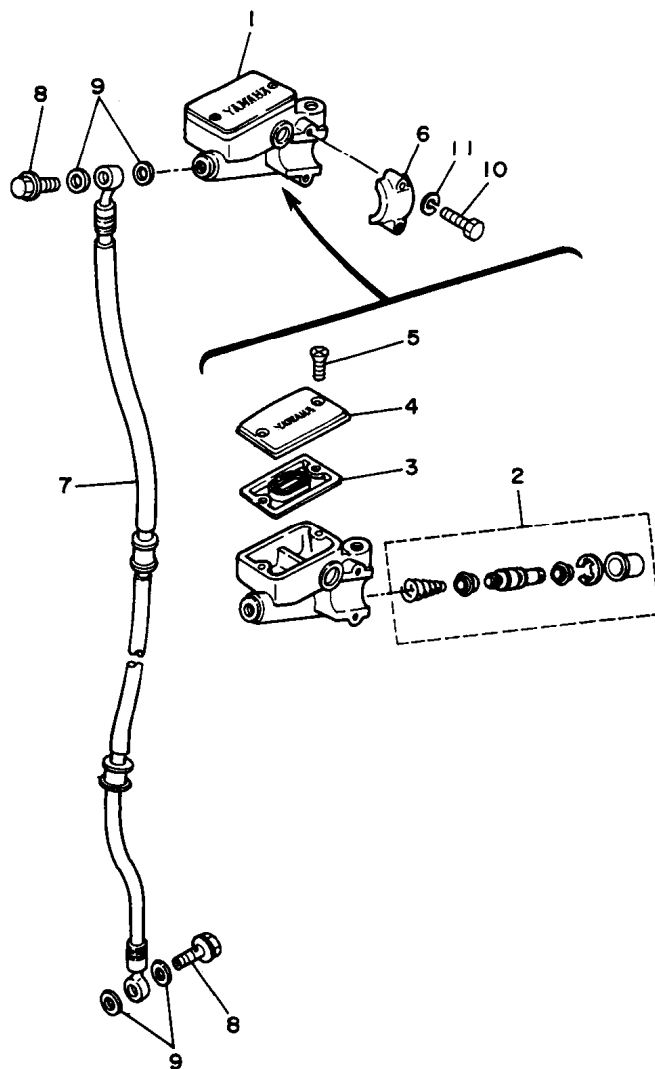

FIG. 30 FRONT MASTER CYLINDER

REF. NO.	PART NO.	DESCRIPTION	Q'TY	REMARKS
1	2UJ-25870-00	MASTER CYLINDER SUB ASSY	1	
2	23L-W0041-00	.CYLINDER KIT, master	1	
3	4L0-25854-00	.DIAPHRAGM, reservoir	1	
4	4H7-25852-00	.CAP, reservoir	1	
5	98707-04012	.SCREW, flat head	2	
6	4L0-25867-00	BRACKET, master cylinder	1	
7	3DN-25872-00	HOSE, brake 1	1	UR
	4XT-F5872-00	HOSE, brake 1	1	UR FOR BRAZIL
8	90401-10159	BOLT, union	2	
9	90201-10118	WASHER, plate	4	
10	97007-06025	BOLT	2	
11	92907-06600	WASHER	2	



3LV7700-5320

D11

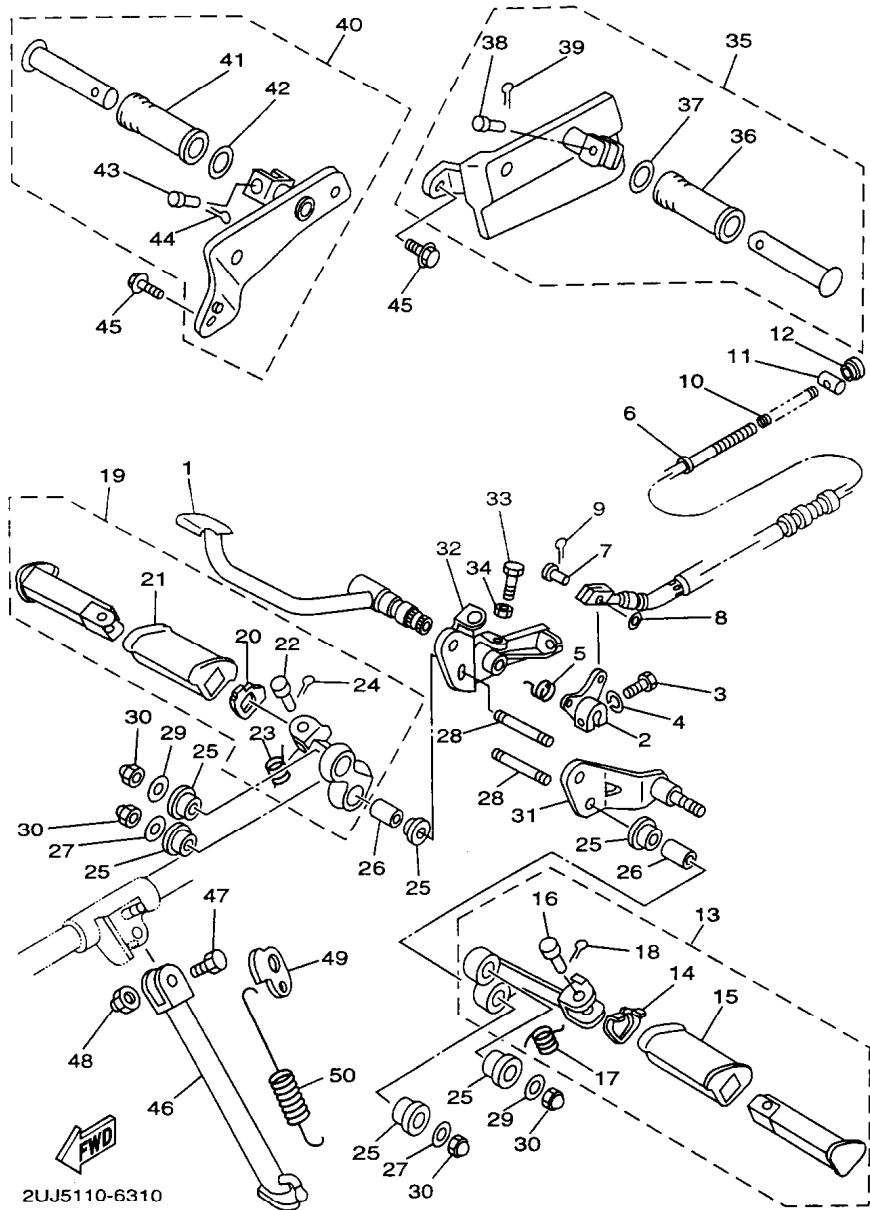

FIG. 31 STAND. FOOTREST

REF. NO.	PART NO.	DESCRIPTION	Q'TY	REMARKS
1	2UJ-27211-01	PEDAL, brake	1	
2	2UJ-27262-02	LEVER	1	
3	90109-06470	BOLT	1	
4	92907-06100	WASHER, spring	1	
5	2UJ-27216-00	SPRING, brake pedal	1	
6	2UJ-26351-00	CABLE, brake	1	
7	91701-06018	PIN, clevis	1	
8	92907-06200	WASHER, plain	1	
9	91401-20015	PIN, cotter	1	
10	90501-10245	SPRING, compression	1	
11	90249-12008	PIN	1	
12	90179-06411	NUT	1	
13	2UJ-27410-00	FRONT FOOTREST ASSY (LEFT)	1	
14	4X7-27417-00	.WASHER, footrest	1	
15	4X7-27413-00	.COVER, footrest	1	
16	91701-08038	.PIN, clevis	1	
17	90508-20023	.SPRING, torsion	1	
18	91401-25020	.PIN, cotter	1	
19	2UJ-27420-00	FRONT FOOTREST ASSY (RIGHT)	1	
20	4X7-27417-00	.WASHER, footrest	1	
21	4X7-27413-00	.COVER, footrest	1	
22	91701-08038	.PIN, clevis	1	
23	90508-20023	.SPRING, torsion	1	
24	91401-25020	.PIN, cotter	1	
25	2UJ-27414-00	DAMPER, footrest	8	
26	90387-100V6	COLLAR	4	
27	90201-100A1	WASHER, plate	2	
28	90116-10519	BOLT, stud	4	

D12

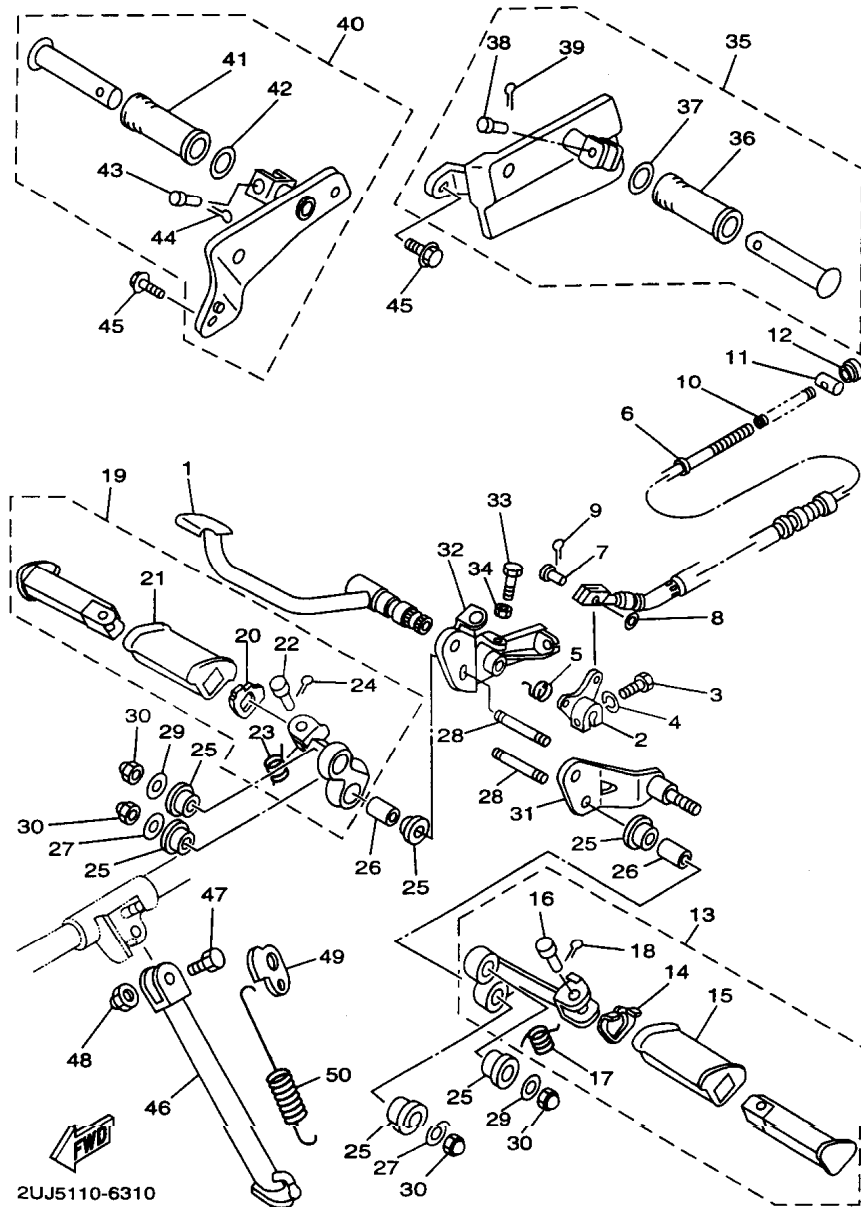
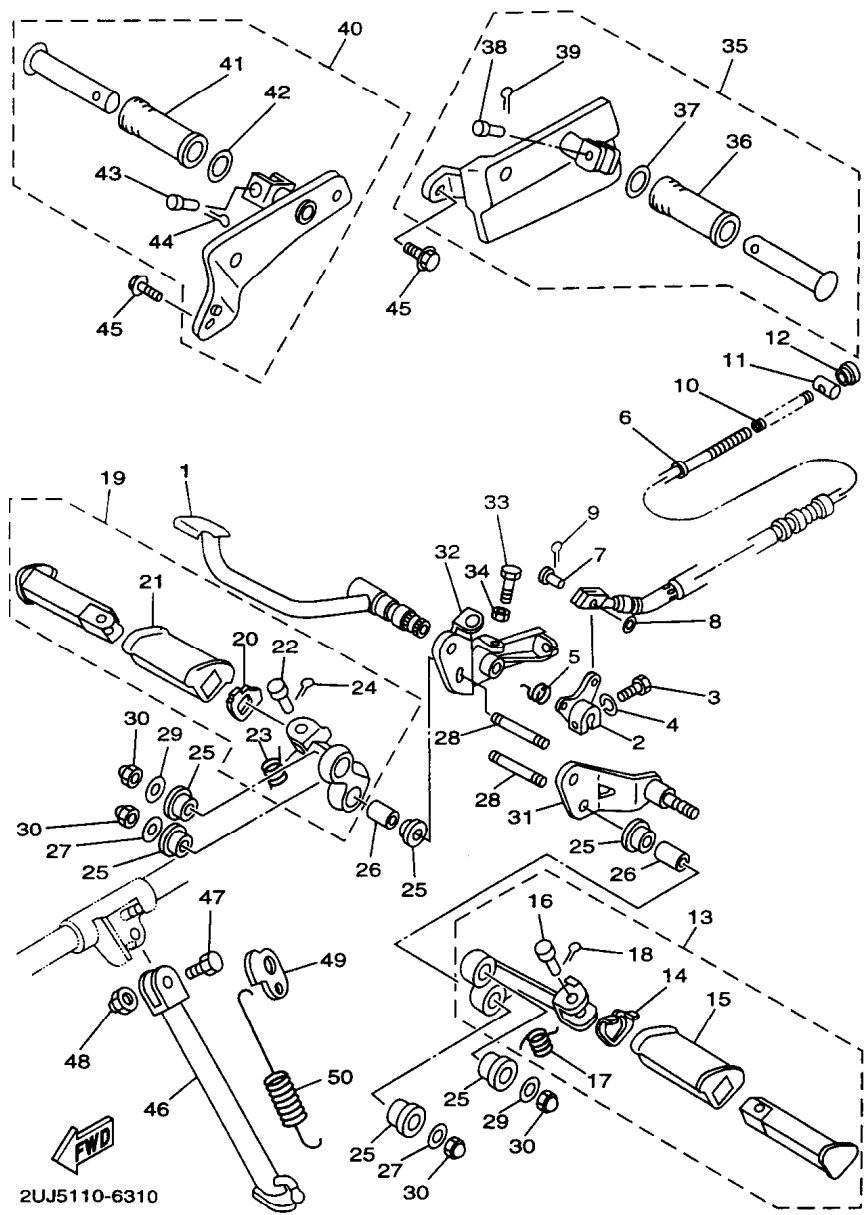

FIG. 31 STAND. FOOTREST

REF. NO.	PART NO.	DESCRIPTION	Q'TY	REMARKS
29	90201-10742	WASHER, plate	2	
30	95380-10800	NUT	4	
31	2UJ-2741L-00-33	BRACKET 4	1	YAMAHA BLACK
32	2UJ-2742L-00-33	BRACKET 5	1	YAMAHA BLACK
33	90153-06008	SCREW, hexagon	1	
34	95307-06600	NUT	1	
35	2UJ-27430-00-33	REAR FOOTREST ASSY 1 (YAMAHA BLACK)	1	UR
	4XT-F7430-00-35	REAR FOOTREST ASSY 1 (SILVER)	1	UR FOR BRAZIL
36	120-27433-00	.COVER, rear footrest	1	UR
	503-F7433-01	.COVER, rear footrest	1	UR FOR BRAZIL
37	90201-20279	.WASHER, plate	1	UR
	90201-20W42	.WASHER, plate	1	UR FOR BRAZIL
38	91701-06032	.PIN, clevis	1	
39	91401-20015	.PIN, cotter	1	
40	2UJ-27440-00-33	REAR FOOTREST ASSY 2 (YAMAHA BLACK)	1	UR
	4XT-F7440-00-35	REAR FOOTREST ASSY 2 (SILVER)	1	UR FOR BRAZIL
41	120-27433-00	.COVER, rear footrest	1	UR
	503-F7433-01	.COVER, rear footrest	1	UR FOR BRAZIL
42	90201-20279	.WASHER, plate	1	UR
	90201-20W42	.WASHER, plate	1	UR FOR BRAZIL
43	91701-06032	.PIN, clevis	1	
44	91401-20015	.PIN, cotter	1	
45	95024-08020	BOLT	2	
46	2UJ-27311-01	STAND, side	1	UR
	4XT-F7311-00	STAND, side	1	UR FOR BRAZIL
47	90109-10474	NUT	1	
48	90185-10037	NUT, self-locking	1	
49	2KT-27315-00	LINK, side stand	1	UR

D13



2UJ5110-6310

FIG. 31 STAND. FOOTREST

REF. NO.	PART NO.	DESCRIPTION	Q'TY	REMARKS
49	4XT-F7315-00	LINK, side stand	1	UR FOR BRAZIL
50	2UJ-27316-00	SPRING, side stand	1	

D14

FIG. 32 GENERATOR

REF. NO.	PART NO.	DESCRIPTION	Q'TY	REMARKS
1	3DM-81410-20	STATOR ASSY	1	
2	3DM-81450-20	ROTOR ASSY	1	
3	98517-06030	SCREW, pan head	3	
4	92907-06100	WASHER, spring	3	
5	98507-05016	SCREW, pan head	2	
6	92907-05100	WASHER, spring	2	

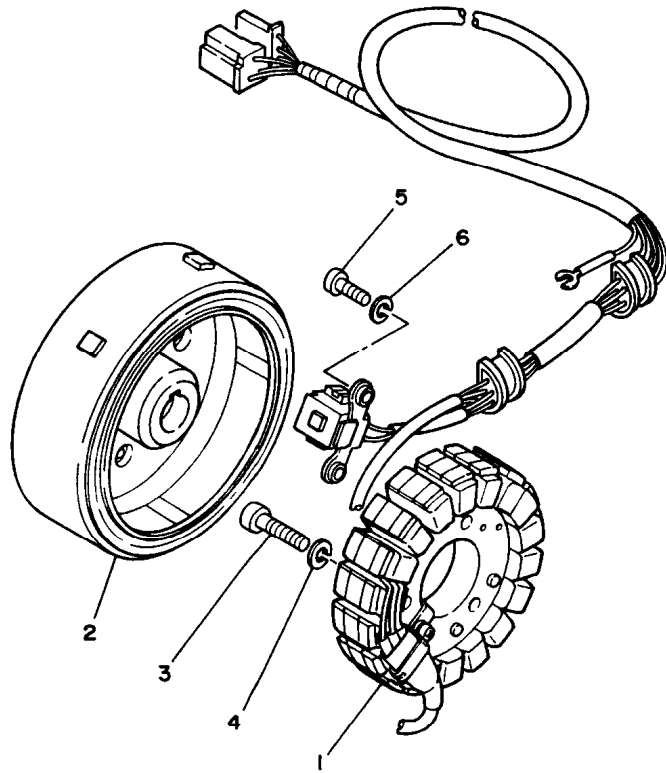

3DM010-8340

D15

FIG. 33 STARTING MOTOR

REF. NO.	PART NO.	DESCRIPTION	Q'TY	REMARKS
1	2UJ-81800-03	STARTING MOTOR ASSY	1	
2	50M-81801-M0	.BRUSH SET	1	
3	93210-55669	.O-RING	1	
4	93210-25711	.O-RING	1	
5	59V-81828-M0	.SCREW SET	1	
6	2UJ-81836-00	.CORD COMP.	1	
7	91314-06020	BOLT	2	

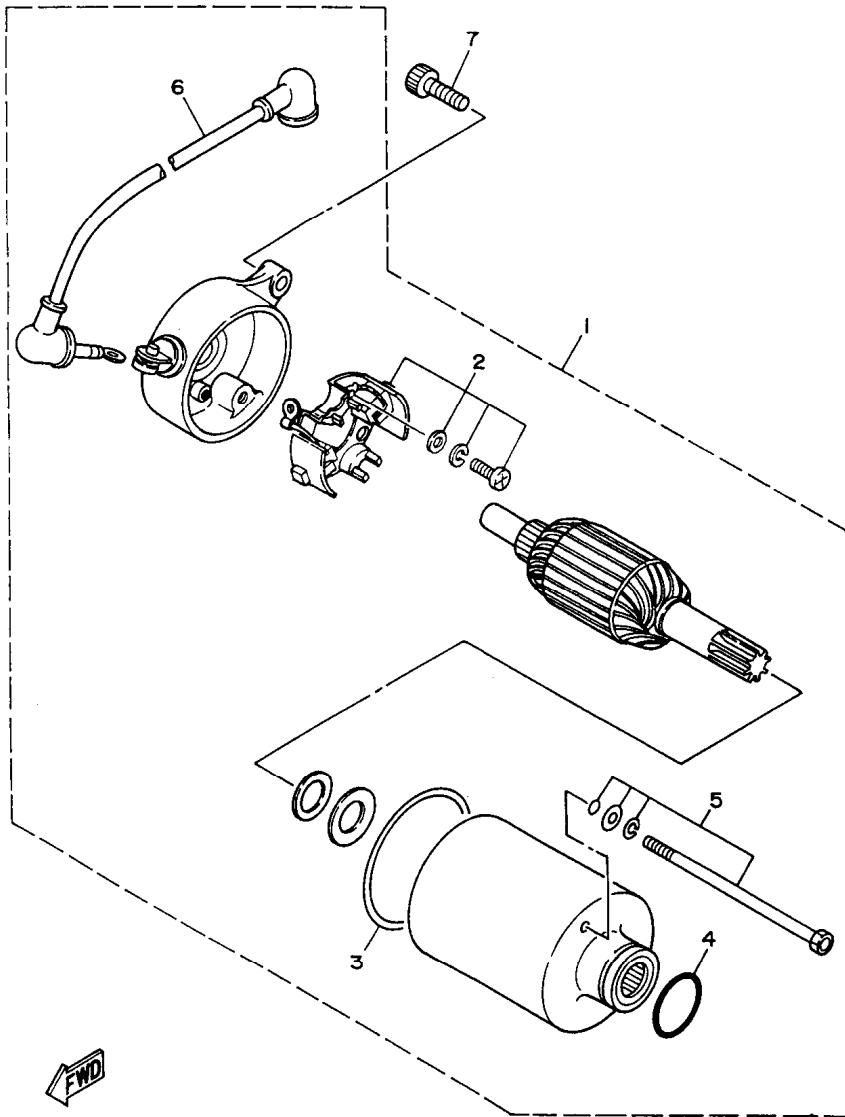

3LS7351-5330

E2

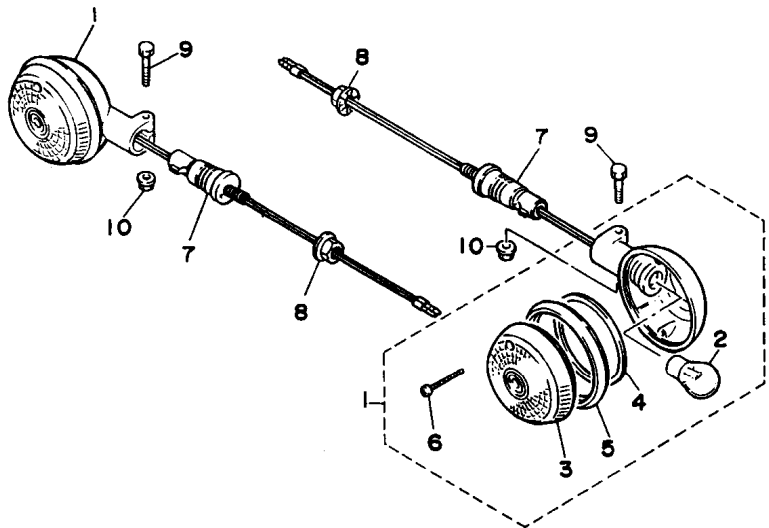
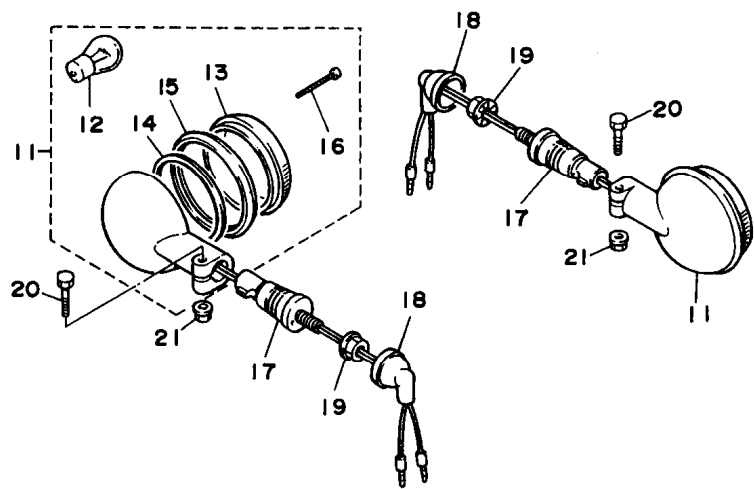

3BMF361-7350

FIG. 34 FLASHER LIGHT

REF. NO.	PART NO.	DESCRIPTION	Q'TY	REMARKS
1	3LS-83310-00	FRONT FLASHER LIGHT ASSY 1	2	
2	1KT-83311-00	.BULB (12V-21W)	1	
3	42X-83312-00	.LENS, flasher	1	
4	42X-83313-00	.GASKET, flasher lens	1	
5	42X-83363-00	.LENS, rim	1	
6	57M-83358-00	.SCREW, special	2	
7	1AA-83318-00	STAY, flasher 1	2	
8	95304-12600	NUT	2	
9	97004-06030	BOLT	2	
10	95704-06500	NUT, flange	2	
11	3LS-83330-00	REAR FLASHER LIGHT ASSY 1	2	UR
	3LU-83330-00	REAR FLASHER LIGHT ASSY 1	2	UR FOR SWITZERLAND
12	1KT-83311-00	.BULB (12V-21W)	1	
13	2AE-83312-00	.LENS, flasher	1	
14	42X-83313-00	.GASKET, flasher lens	1	
15	42X-83363-00	.LENS, rim	1	
16	57M-83358-00	.SCREW, special	2	
17	1AA-83318-00	STAY, flasher 1	2	
18	18G-83365-00	CAP	2	
19	95304-12600	NUT	2	
20	97004-06030	BOLT	2	
21	95704-06500	NUT, flange	2	

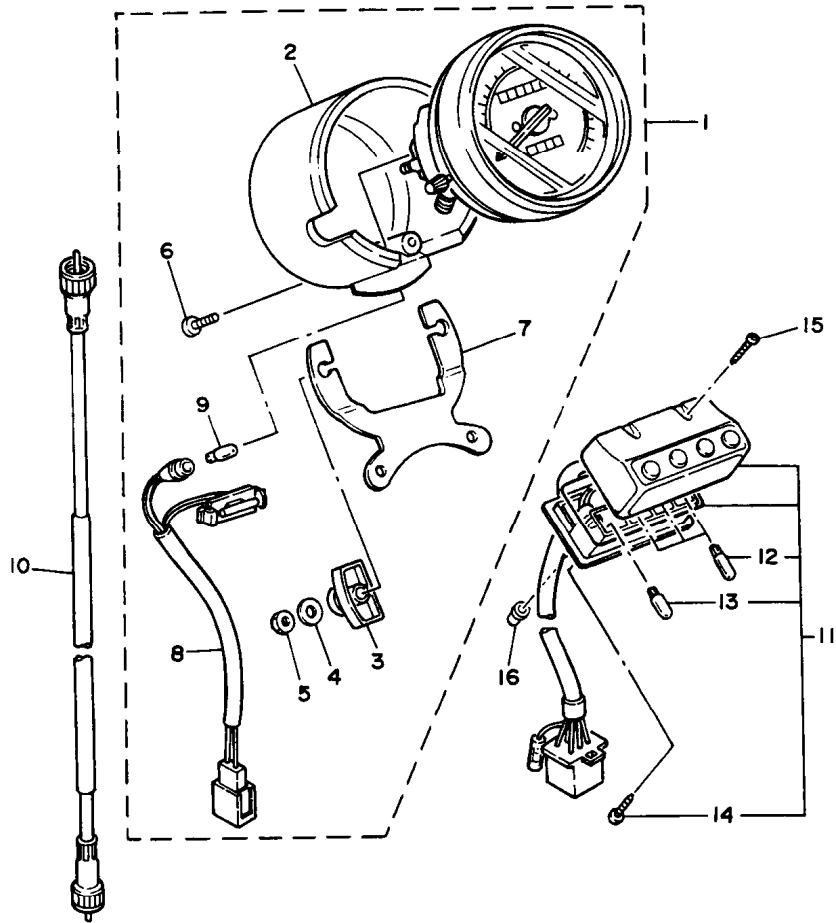

FIG. 35 METER

REF. NO.	PART NO.	DESCRIPTION	Q'TY	REMARKS
1	3DM-83570-01	SPEEDOMETER ASSY	1	
2	2UJ-83507-00	.COVER, speedometer	1	
3	1FG-83523-00	.DAMPER	2	
4	90201-05725	.WASHER, plate	2	
5	95303-05600	.NUT	2	
6	90164-04009	.SCREW, tapping	1	
7	2GV-83519-00	.BRACKET, meter	1	
8	2UJ-83509-00	.SOCKET CORD ASSY	1	
9	42X-83517-00	.BULB (12V-3W)	1	
10	3Y0-83550-01	SPEEDOMETER CABLE ASSY	1	
11	3BT-83530-10	PILOT LIGHT ASSY	1	
12	42X-83517-00	.BULB (12V-3W)	2	
13	2GV-83517-00	.BULB (12V-1.7W, T6.5)	1	
14	4AS-84616-10	.SCREW, tapping	1	
15	98507-04035	SCREW, pan head	2	
16	90179-04579	NUT	2	

FWD

3DM010-8370

E4

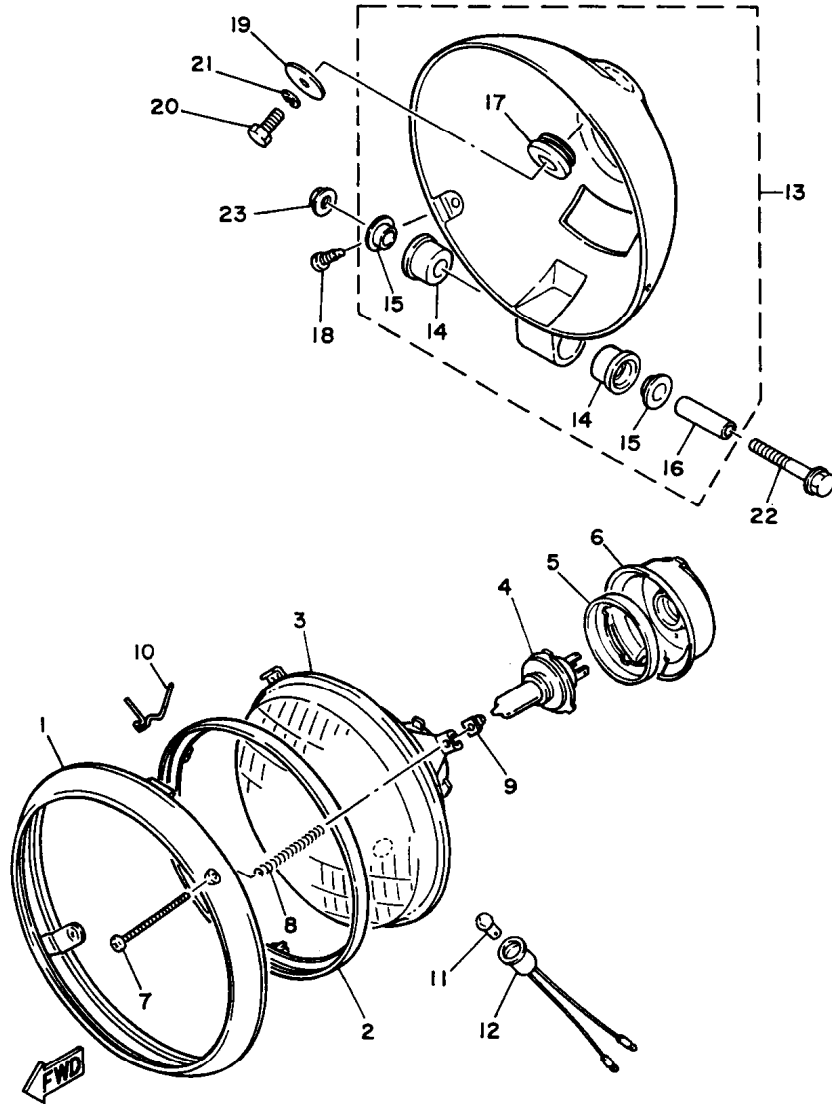

3DM010-8380

FIG. 36 HEADLIGHT

REF. NO.	PART NO.	DESCRIPTION	Q'TY	REMARKS
1	42X-84315-01	RIM, headlight	1	
2	5Y3-84395-00	RING, retaining	1	
3	2AE-84320-60	LENS ASSY	1	
4	*	BULB (12V-60/55W)	1	LM HALOGEN
5	2F9-84375-00	FITTING PLATE, bulb	1	
6	2F9-84397-01	COVER, socket	1	
7	90157-04001	SCREW, pan head	2	
8	1A0-84332-60	SPRING, screw	2	
9	198-84334-60	NUT, adjusting	2	
10	42X-84124-60	SPRING, set	1	
11	4E2-84347-00	BULB (12V-4W)	1	
12	34L-84346-00	SOCKET, pilot light	1	
13	42X-84330-01	BODY ASSY	1	
14	42X-84345-00	.DAMPER, headlight	2	
15	1FK-84338-00	.COLLAR, body fitting	2	
16	2UJ-84338-00	.COLLAR, body fitting	1	
17	42X-84366-00	.DAMPER, headlight 1	1	
18	90157-05084	SCREW, pan head	2	
19	90201-06073	WASHER, plate	1	
20	97007-06016	BOLT	1	
21	92907-06100	WASHER, spring	1	
22	95824-06045	BOLT, flange	1	
23	95704-06500	NUT, flange	1	

E5

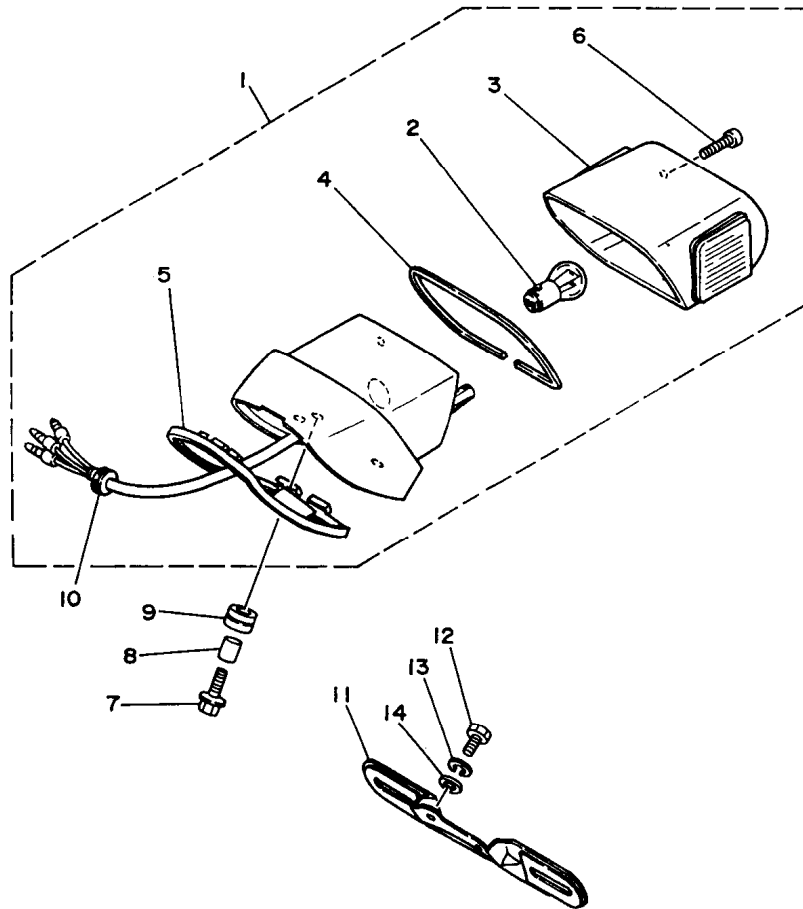

FIG. 37 TAILLIGHT

REF. NO.	PART NO.	DESCRIPTION	Q'TY	REMARKS
1	3LS-84700-00	TAILLIGHT ASSY	1	
2	31L-84714-00	.BULB, taillight (12V-21/5W)	1	
3	3LS-84721-00	.LENS, taillight	1	
4	2UJ-84723-00	.GASKET, tail lens	1	
5	2UJ-84704-00	.GASKET, taillight	1	
6	97707-40525	.SCREW, tapping	2	
7	90119-06182	BOLT, with washer	3	
8	90387-061V1	COLLAR	3	
9	90480-14229	GROMMET	3	
10	90480-16501	GROMMET	1	
11	3LS-84751-00	BRACKET, license	1	UR
	4XT-F4751-00	BRACKET, license	1	UR FOR BRAZIL
12	97004-06014	BOLT	2	
13	92990-06100	WASHER, spring	2	
14	92901-06600	WASHER, plate	2	



3LS1332-9370

E6

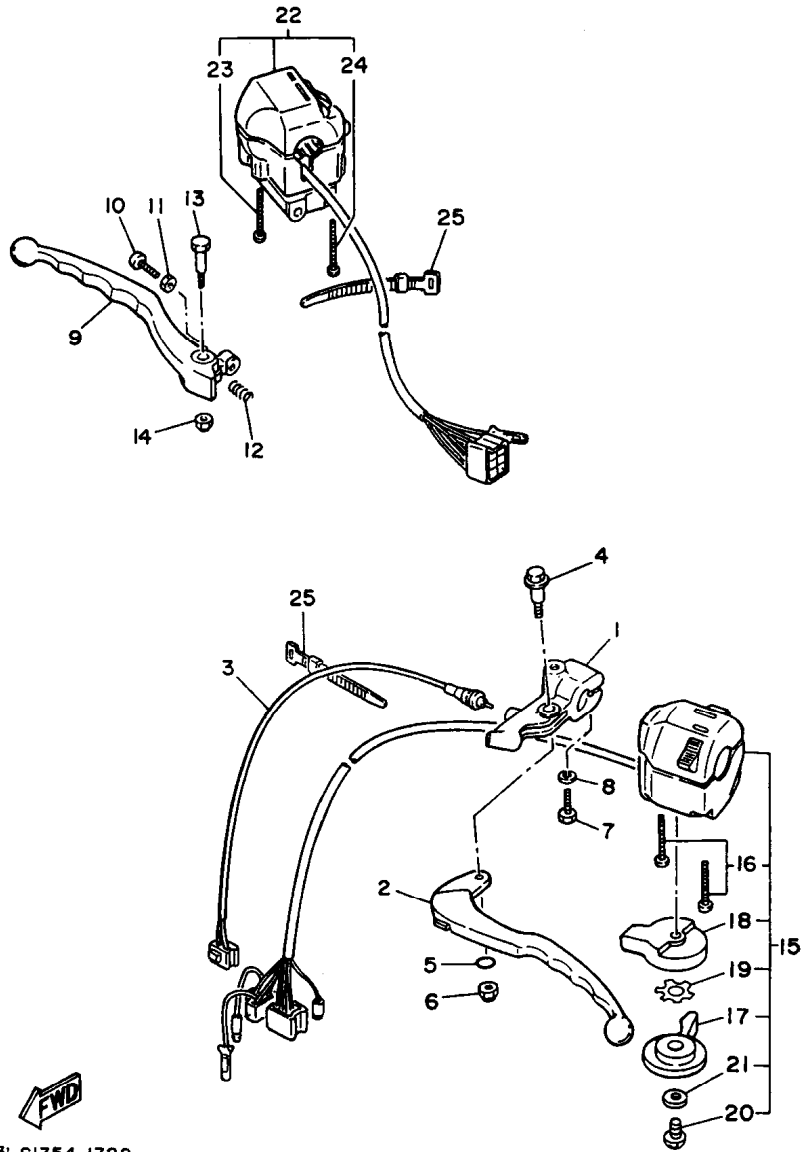
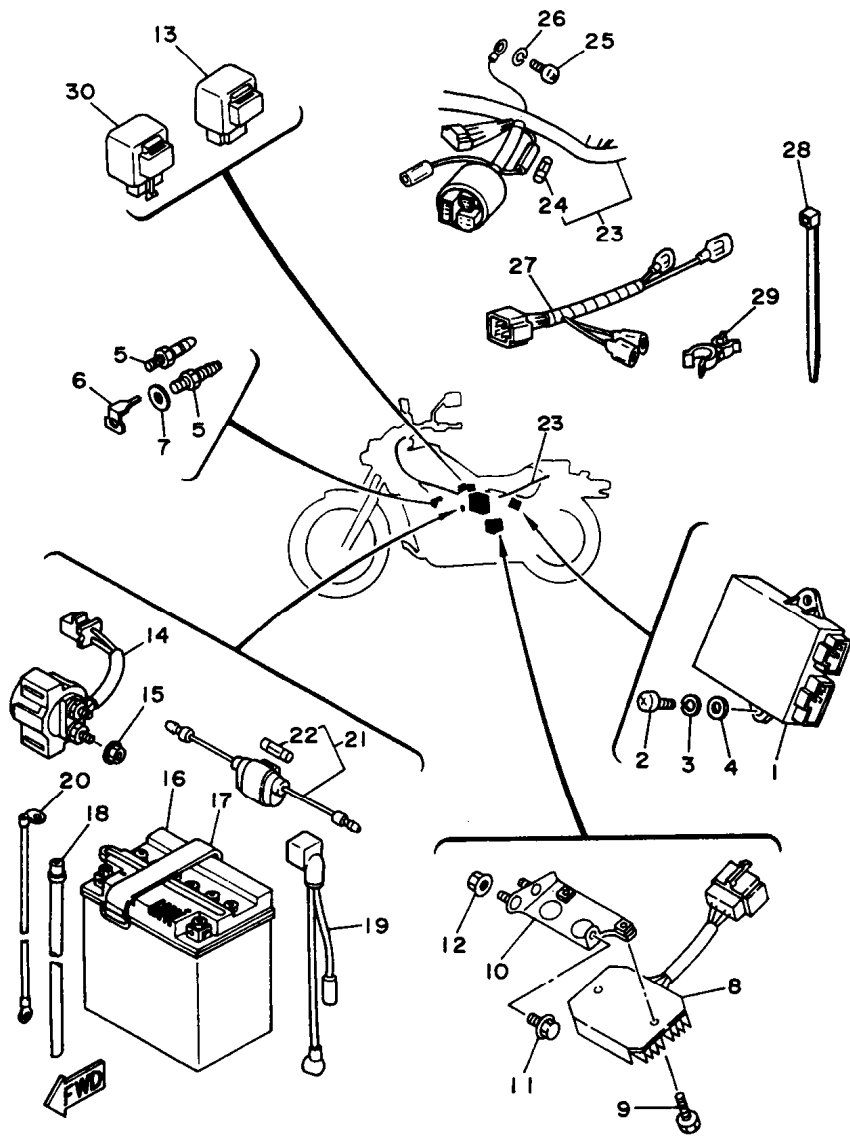

FIG. 38 HANDLE SWITCH. LEVER

REF. NO.	PART NO.	DESCRIPTION	Q'TY	REMARKS
1	10M-82911-00	HOLDER, lever 1	1	
2	2GV-83912-00	LEVER 1	1	
3	2UJ-82917-00	SWITCH	1	
4	90109-06799	BOLT	1	
5	93210-11368	O-RING	1	
6	95607-06100	NUT, u	1	
7	97007-06025	BOLT	1	
8	92907-06100	WASHER, spring	1	
9	2W1-83922-00	LEVER 2	1	
10	90149-06131	SCREW	1	
11	90170-06010	NUT	1	
12	90501-10312	SPRING, compression	1	
13	90109-06577	BOLT	1	
14	95607-06100	NUT, u	1	
15	3DM-83972-00	SWITCH, handle 4	1	
16	98506-05035	.SCREW, pan head	2	
17	10M-83941-00	.LEVER, starter	1	
18	10M-83942-00	.COVER, starter	1	
19	90209-10131	.WASHER	1	
20	98506-06008	.SCREW, pan head	1	
21	92901-06200	.WASHER, plain	1	
22	3DM-83973-10	SWITCH, handle 3	1	
23	98506-05040	.SCREW, pan head	1	
24	98506-05045	.SCREW, pan head	1	
25	437-83936-01	BAND, switch cord	3	

3LS1354-1380

E7



3LS7351-5390

FIG. 39 ELECTRICAL 1

REF. NO.	PART NO.	DESCRIPTION	Q'TY	REMARKS
1	3LS-82305-00	IGNITOR UNIT ASSY	1	
2	98507-06016	SCREW, pan head	1	
3	92907-06100	WASHER, spring	1	
4	92907-06600	WASHER, plate	1	
5	3BT-83790-00	HEATER ASSY	2	
6	3BT-82103-00	TERMINAL 1	1	
7	90201-085R5	WASHER, plate	2	
8	3LS-81960-00	RECTIFIER & REGULATOR ASSY	1	
9	90109-067E6	BOLT	2	
10	3DM-21287-00	BRACKET, regulator	1	
11	95807-06010	BOLT, flange	1	
12	95707-06500	NUT, flange	2	
13	2UJ-81950-00	RELAY ASSY	1	
14	36Y-81940-00	STARTER RELAY ASSY	1	
15	95707-06500	NUT, flange	2	
16	3DN-82110-00	BATTERY ASSY (G.S. GM10-3A-2)	1	
17	118-82131-00	BAND, battery	1	
18	90445-08248	HOSE	1	
19	2UJ-82115-00	WIRE, plus lead	1	
20	2UJ-82116-00	WIRE, minus lead	1	
21	2UJ-82150-02	FUSE HOLDER ASSY	1	
22	148-82151-00	.FUSE (20A)	1	
23	3LS-82590-20	WIRE HARNESS ASSY	1	
24	1E6-82151-00	.FUSE (10A)	2	
25	98507-06010	SCREW, pan head	1	
26	92907-06100	WASHER	1	
27	2UJ-82509-00	WIRE, sub lead	1	
28	12R-82591-00	BAND	2	

E8

FIG. 39 ELECTRICAL 1

REF. NO.	PART NO.	DESCRIPTION	Q'TY	REMARKS
29	90464-16119	CLAMP	1	
30	3GM-83350-01	FLASHER RELAY ASSY	1	

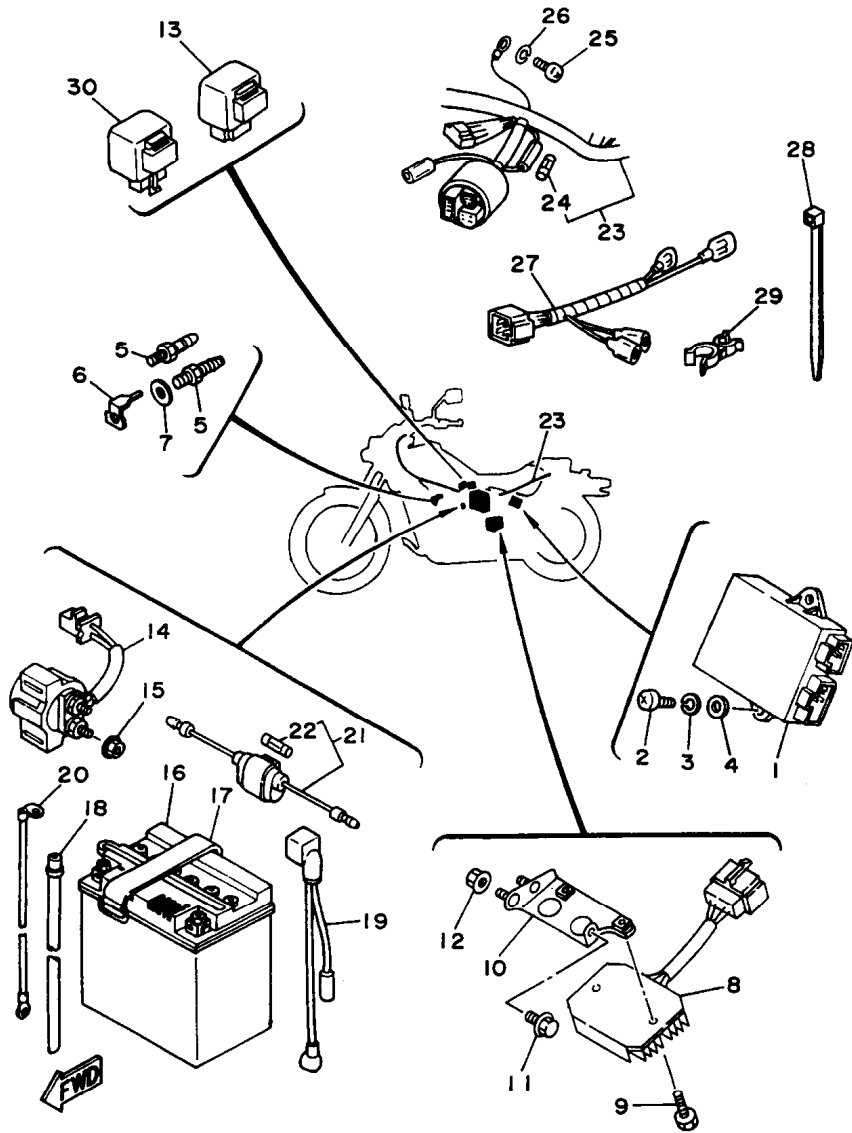

3LS735I-5390

E9

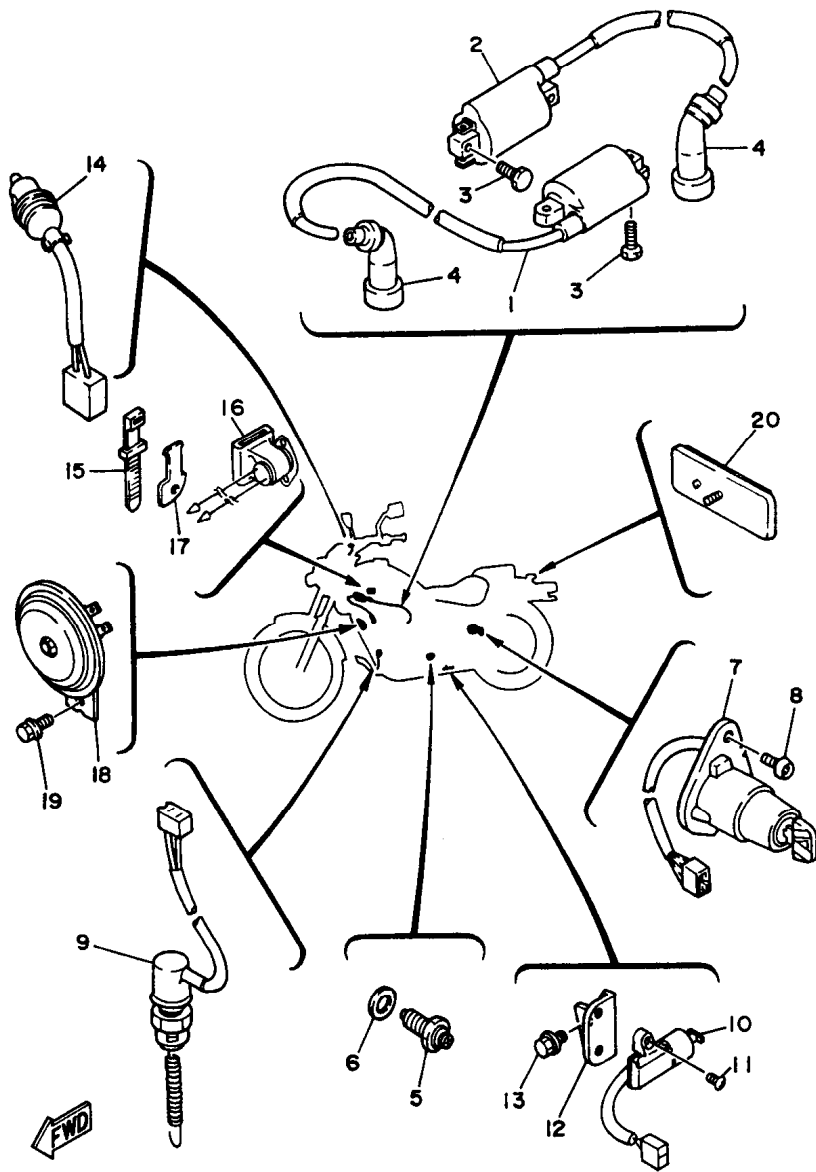

3LS7351-5400

FIG. 40 ELECTRICAL 2

REF. NO.	PART NO.	DESCRIPTION	Q'TY	REMARKS
1	2UJ-82310-00	IGNITION COIL ASSY	1	
2	2UJ-82320-00	IGNITION COIL ASSY	1	
3	97007-05020	BOLT	4	
4	1UY-82370-20	PLUG CAP ASSY	2	
5	4KM-82540-00	NEUTRAL SWITCH ASSY	1	
6	90430-10148	GASKET	1	
7	3DM-82510-00	MAIN SWITCH ASSY	1	
8	90149-06228	SCREW	2	
9	3XV-82530-01	STOP SWITCH ASSY	1	
10	3LD-82566-60	SWITCH, side stand	1	
11	90157-05079	SCREW	2	
12	2UJ-82565-00	PANEL, switch	1	UR
	4XT-H2565-00	PANEL, switch	1	UR FOR BRAZIL
13	95807-06010	BOLT	1	
14	2UJ-83980-00	FRONT STOP SWITCH ASSY	1	
15	437-83936-11	BAND, switch cord	2	
16	3BT-82560-00	THERMO SWITCH ASSY	1	
17	3DM-82571-00	PANEL, switch	1	UR
	3BG-82571-00	PANEL, switch	1	UR FOR SWITZERLAND
	4XT-H2571-00	PANEL, switch	1	UR FOR BRAZIL
18	3BN-83371-00	HORN	1	
19	95807-06010	BOLT, flange	1	
20	3Y6-85130-02	REAR REFLECTOR ASSY	1	

INDIVIDUAL SPEC.

FOR SWITZERLAND

The following pages provides a listing of only the parts that meet the specifications peculiar to your market. For those parts not appearing in these pages, refer to the "GENERAL SPEC." section.

FIG. 41 ALTERNATE (FRONT FORK)

REF. NO.	PART NO.	DESCRIPTION	Q'TY	REMARKS
1	*	STEERING LOCK ASSY	*	
2	2A6-23408-00	STEERING LOCK ASSY	1	
3	134-23484-10	CAP, handle lock	*	
4	3DM-23484-00	CAP, handle lock	1	
5	90502-09024	SPRING, conical	1	

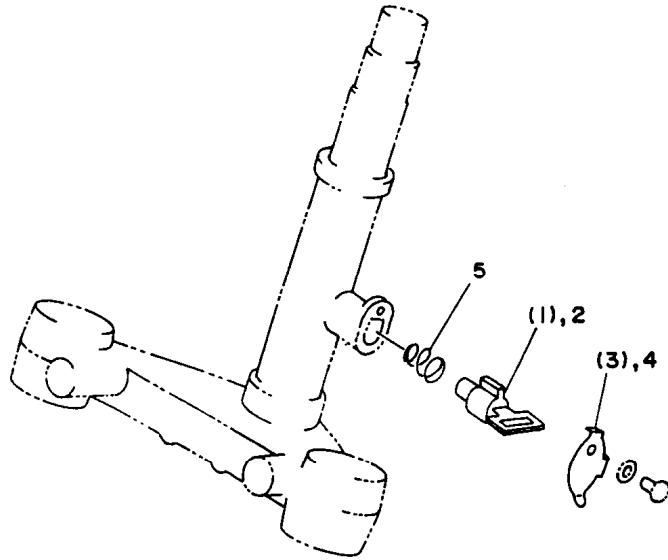

3LSH300-7410

* For convenience of reference:

Disregard the items asterisked (*) in the "QTY" column. These are intended for GENERAL SPEC, and NOT for INDIVIDUAL SPEC.

E12

FOR ITALY

The following pages provides a listing of only the parts that meet the specifications peculiar to your market. For those parts not appearing in these pages, refer to the "GENERAL SPEC." section.

FIG. 42 ALTERNATE (FRONT FORK)

REF. NO.	PART NO.	DESCRIPTION	Q'TY	REMARKS
1	*	STEERING LOCK ASSY	*	
2	2A6-23408-00	STEERING LOCK ASSY	1	
3	134-23484-10	CAP, handle lock	*	
4	3DM-23484-00	CAP, handle lock	1	
5	90502-09024	SPRING, conical	1	

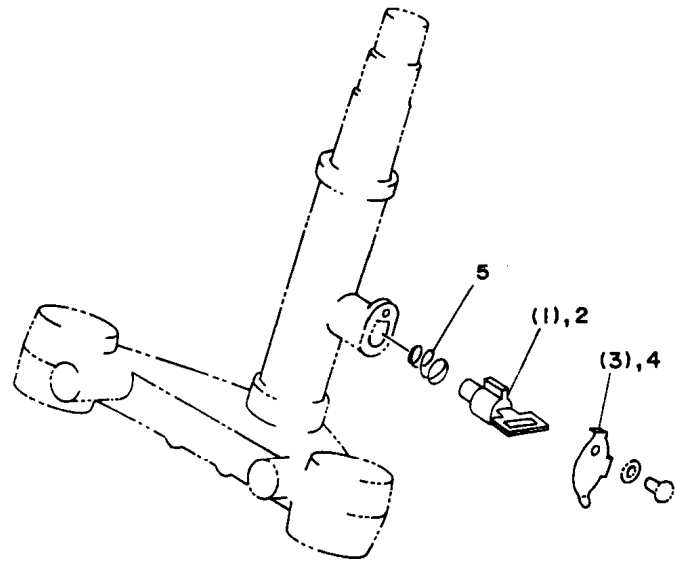

3LSH300-7410

* For convenience of reference:

Disregard the items asterisked (*) in the "QTY" column. These are intended for GENERAL SPEC, and NOT for INDIVIDUAL SPEC.

E14

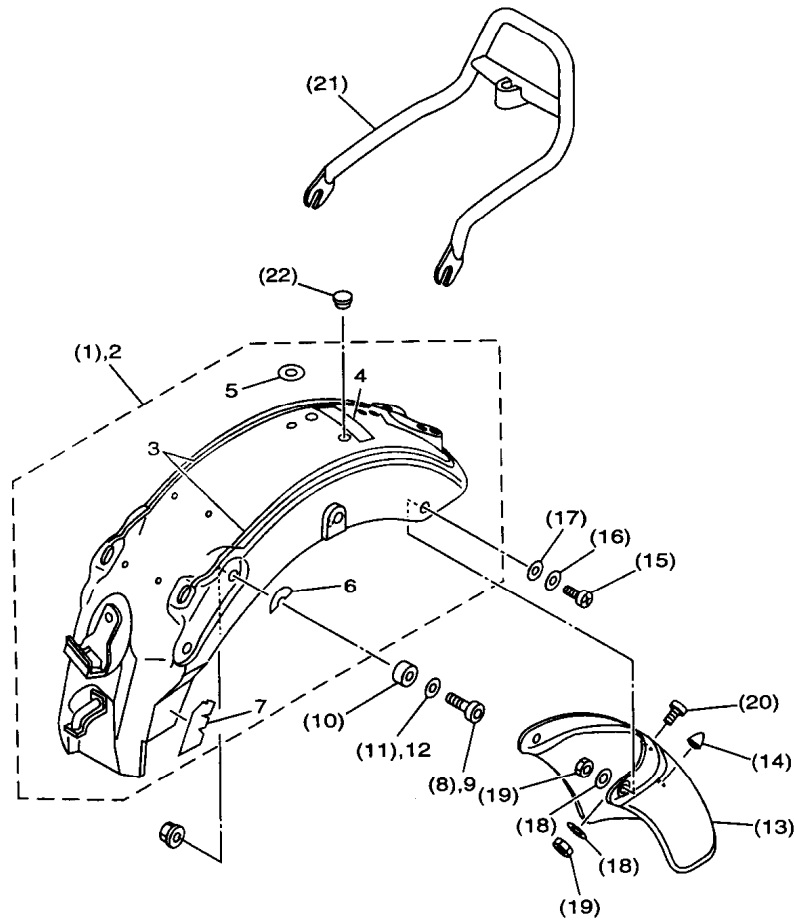

FIG. 43 ALTERNATE (FENDER)

REF. NO.	PART NO.	DESCRIPTION	Q'TY	REMARKS
1	3LS-Y2161-80-0X	REAR FENDER COMP.	*	UR MAPLE RED/SILKY GOLD
	3LS-Y2161-90-1X	REAR FENDER COMP.	*	UR MIDNIGHT SILVER/ BLACK 2
2	2UJ-Y2161-00-6X	REAR FENDER COMP.	1	UR MAPLE RED/SILKY GOLD
	2UJ-Y2161-20-7X	REAR FENDER COMP.	1	UR MIDNIGHT SILVER/ BLACK 2
3	3DM-2165A-81	.GRAPHIC, rear fender	1	UR FOR MPR
	3DM-2165A-80	.GRAPHIC, rear fender	1	UR FOR MDS
4	99237-00080	.EMBLEM, yamaha	1	
5	2UJ-21735-00	.SEAL 2	1	
6	3DM-2173N-00	.SEAL 4	2	
7	2UJ-2173M-01	.SEAL 3	1	
8	92014-10050	BOLT	*	
9	91317-10035	BOLT	2	
10	90387-100E2	COLLAR	*	
11	92990-10200	WASHER, plain	*	
12	92907-10600	WASHER	2	
13	3LS-21621-00	FLAP	*	
14	4G0-21639-00	DAMPER 2	*	
15	98517-06012	SCREW, pan head	*	
16	92907-06600	WASHER, plate	*	
17	90202-05187	WASHER, plate	*	
18	92907-06200	WASHER, plain	*	
19	95307-06600	NUT	*	
20	98904-06014	SCREW, bind	*	
21	3LS-21640-00	REAR STAY COMP.	*	
22	1J3-24742-00	GROMMET	*	

* For convenience of reference:

Disregard the items asterisked (*) in the "QTY" column. These are intended for GENERAL SPEC, and NOT for INDIVIDUAL SPEC.



3LSH300-7430

E15

FIG. 44 ALTERNATE (SEAT)

REF. NO.	PART NO.	DESCRIPTION	Q'TY	REMARKS
1	3LS-24750-10	TANDEM SEAT ASSY	*	
2	3DM-24750-10	TANDEM SEAT ASSY	1	
3	3DM-24751-10	.COVER, tandem seat	1	
4	509-24724-00	.DAMPER, seat	4	
5	2UJ-24734-00	.BAND, seat	1	
6	1WG-24712-00	.PLATE	2	
7	47X-24739-00	.BOLT, seat fitting	2	
8	90173-06015	.NUT, square	2	
9	90468-10050	.CLIP	2	
10	2UJ-2471A-00	.STAY, seat	1	
11	95707-06500	.NUT, flange	2	
12	92014-08035	BOLT, button head	*	
13	95024-08012	BOLT, flange	1	

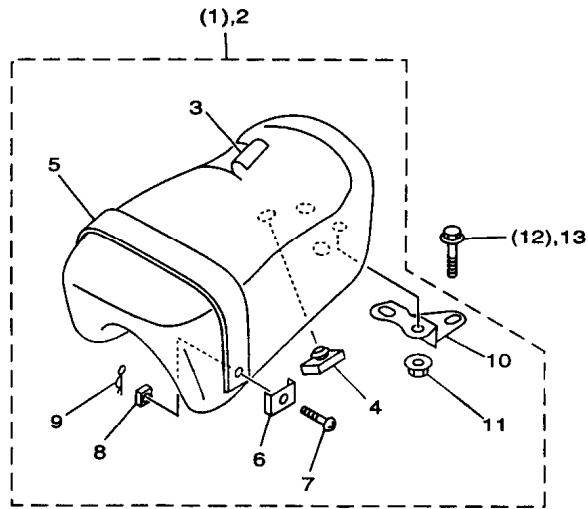

3LSH300-7440

* For convenience of reference:

Disregard the items asterisked (*) in the "QTY" column. These are intended for GENERAL SPEC, and NOT for INDIVIDUAL SPEC.

F2

FOR SPAIN

The following pages provides a listing of only the parts that meet the specifications peculiar to your market. For those parts not appearing in these pages, refer to the "GENERAL SPEC." section.

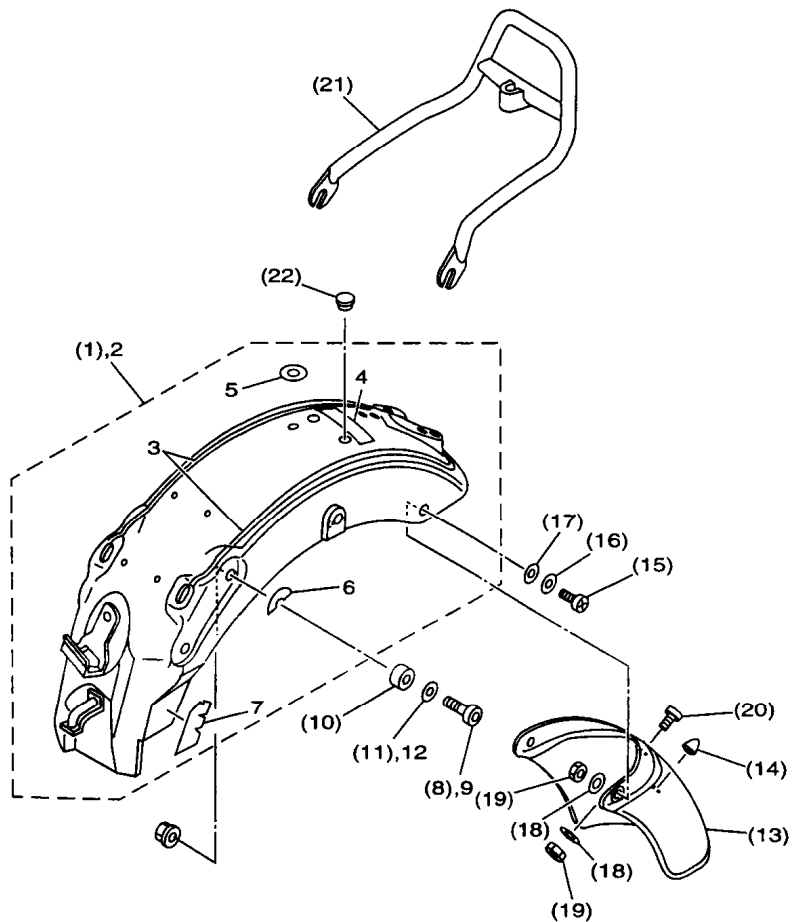

FIG. 45 ALTERNATE (FENDER)

REF. NO.	PART NO.	DESCRIPTION	Q'TY	REMARKS
1	3LS-Y2161-80-0X	REAR FENDER COMP.	*	UR MAPLE RED/SILKY GOLD
	3LS-Y2161-90-1X	REAR FENDER COMP.	*	UR MIDNIGHT SILVER/BLACK 2
2	2UJ-Y2161-00-6X	REAR FENDER COMP.	1	UR MAPLE RED/SILKY GOLD
	2UJ-Y2161-20-7X	REAR FENDER COMP.	1	UR MIDNIGHT SILVER/BLACK 2
3	3DM-2165A-81	.GRAPHIC, rear fender	1	UR FOR MPR
	3DM-2165A-B0	.GRAPHIC, rear fender	1	UR FOR MDS.
4	99237-00080	.EMBLEM, yamaha	1	
5	2UJ-21735-00	.SEAL 2	1	
6	3DM-2173N-00	.SEAL 4	2	
7	2UJ-2173M-01	.SEAL 3	1	
8	92014-10050	BOLT	*	
9	91317-10035	BOLT	2	
10	90387-100E2	COLLAR	*	
11	92990-10200	WASHER, plain	*	
12	92907-10600	WASHER	2	
13	3LS-21621-00	FLAP	*	
14	4G0-21639-00	DAMPER 2	*	
15	98517-06012	SCREW, pan head	*	
16	92907-06600	WASHER, plate	*	
17	90202-05187	WASHER, plate	*	
18	92907-06200	WASHER, plain	*	
19	95307-06600	NUT	*	
20	98904-06014	SCREW, bind	*	
21	3LS-21640-00	REAR STAY COMP.	*	
22	1J3-24742-00	GROMMET	*	

* For convenience of reference:

Disregard the items asterisked (*) in the "QTY" column. These are intended for GENERAL SPEC, and NOT for INDIVIDUAL SPEC.



3LSH300-7430

F4

FIG. 46 ALTERNATE (SEAT)

REF. NO.	PART NO.	DESCRIPTION	Q'TY	REMARKS
1	3LS-24750-10	TANDEM SEAT ASSY	*	
2	3DM-24750-10	TANDEM SEAT ASSY	1	
3	3DM-24751-10	.COVER, tandem seat	1	
4	509-24724-00	.DAMPER, seat	4	
5	2UJ-24734-00	.BAND, seat	1	
6	1WG-24712-00	.PLATE	2	
7	47X-24739-00	.BOLT, seat fitting	2	
8	90173-06015	.NUT, square	2	
9	90468-10050	.CLIP	2	
10	2UJ-2471A-00	.STAY, seat	1	
11	95707-06500	.NUT, flange	2	
12	92014-08035	BOLT, button head	*	
13	95024-08012	BOLT, flange	1	

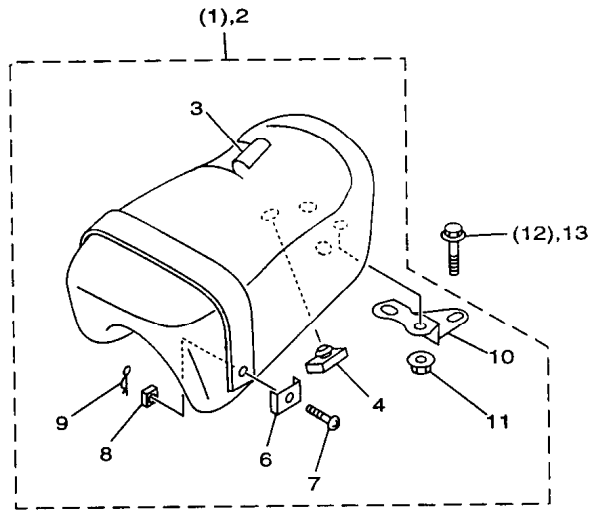

3LSH300-7440

* For convenience of reference:

Disregard the items asterisked (*) in the "QTY" column. These are intended for GENERAL SPEC, and NOT for INDIVIDUAL SPEC.

F5

FOR ENGLAND

The following pages provides a listing of only the parts that meet the specifications peculiar to your market. For those parts not appearing in these pages, refer to the "GENERAL SPEC." section.

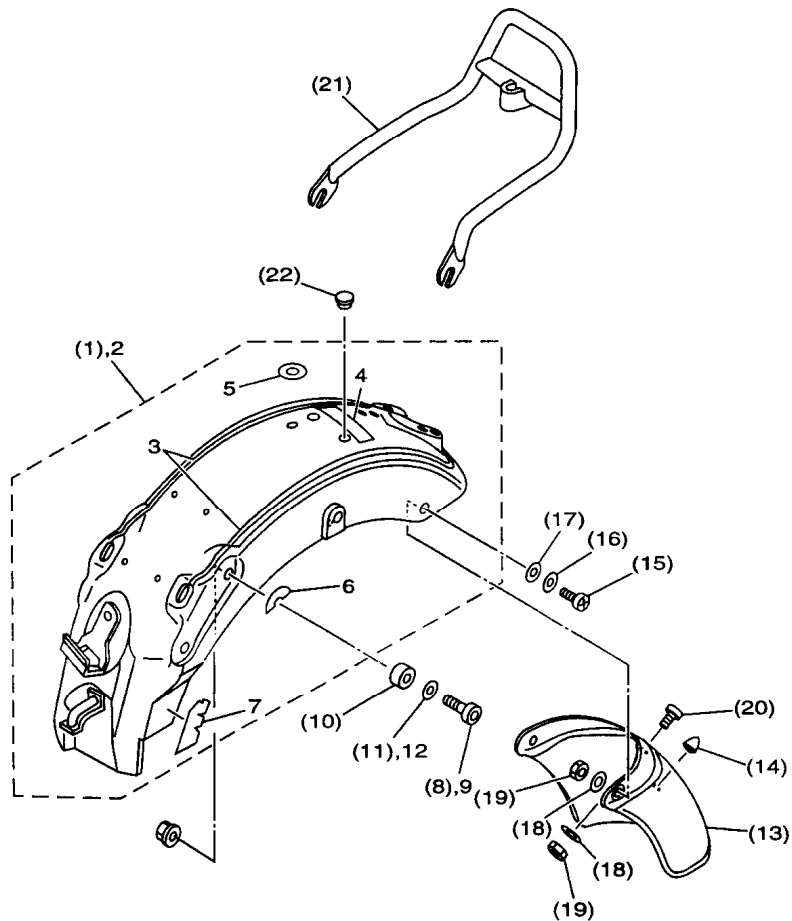

FIG. 47 ALTERNATE (FENDER)

REF. NO.	PART NO.	DESCRIPTION	Q'TY	REMARKS
1	3LS-Y2161-80-0X	REAR FENDER COMP.	*	UR MAPLE RED/SILKY GOLD
	3LS-Y2161-90-1X	REAR FENDER COMP.	*	UR MIDNIGHT SILVER/ BLACK 2
2	2UJ-Y2161-00-6X	REAR FENDER COMP.	1	UR MAPLE RED/SILKY GOLD
	2UJ-Y2161-20-7X	REAR FENDER COMP.	1	UR MIDNIGHT SILVER/ BLACK 2
3	3DM-2165A-81	.GRAPHIC, rear fender	1	UR FOR MPR
	3DM-2165A-B0	.GRAPHIC, rear fender	1	UR FOR MDS
4	99237-00080	.EMBLEM, yamaha	1	
5	2UJ-21735-00	.SEAL 2	1	
6	3DM-2173N-00	.SEAL 4	2	
7	2UJ-2173M-01	.SEAL 3	1	
8	92014-10050	BOLT	*	
9	91317-10035	BOLT	2	
10	90387-100E2	COLLAR	*	
11	92990-10200	WASHER, plain	*	
12	92907-10600	WASHER	2	
13	3LS-21621-00	FLAP	*	
14	4G0-21639-00	DAMPER 2	*	
15	98517-06012	SCREW, pan head	*	
16	92907-06600	WASHER, plate	*	
17	90202-05187	WASHER, plate	*	
18	92907-06200	WASHER, plain	*	
19	95307-06600	NUT	*	
20	98904-06014	SCREW, bind	*	
21	3LS-21640-00	REAR STAY COMP.	*	
22	1J3-24742-00	GROMMET	*	

* For convenience of reference:

Disregard the items asterisked (*) in the "QTY" column. These are intended for GENERAL SPEC, and NOT for INDIVIDUAL SPEC.



3LSH300-7430

F7

FIG. 48 ALTERNATE (SEAT)

REF. NO.	PART NO.	DESCRIPTION	Q'TY	REMARKS
1	3LS-24750-10	TANDEM SEAT ASSY	*	
2	3DM-24750-10	TANDEM SEAT ASSY	1	
3	3DM-24751-10	.COVER, tandem seat	1	
4	509-24724-00	.DAMPER, seat	4	
5	2UJ-24734-00	.BAND, seat	1	
6	1WG-24712-00	.PLATE	2	
7	47X-24739-00	.BOLT, seat fitting	2	
8	90173-06015	.NUT, square	2	
9	90468-10050	.CLIP	2	
10	2UJ-2471A-00	.STAY, seat	1	
11	95707-06500	.NUT, flange	2	
12	92014-08035	BOLT, button head	*	
13	95024-08012	BOLT, flange	1	

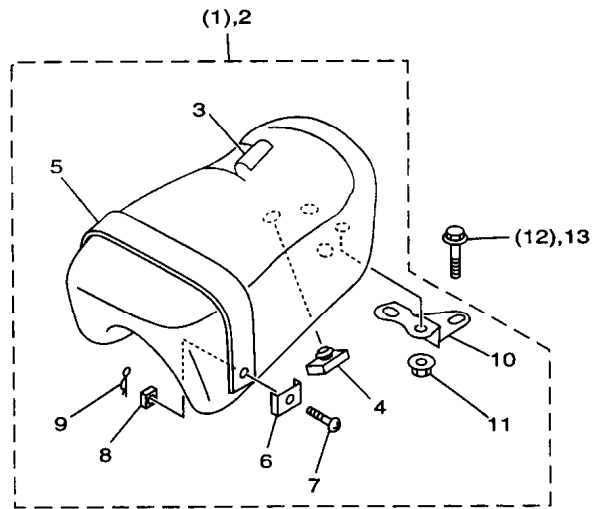

3LSH300-7440

* For convenience of reference:

Disregard the items asterisked (*) in the "QTY" column. These are intended for GENERAL SPEC, and NOT for INDIVIDUAL SPEC.

F8

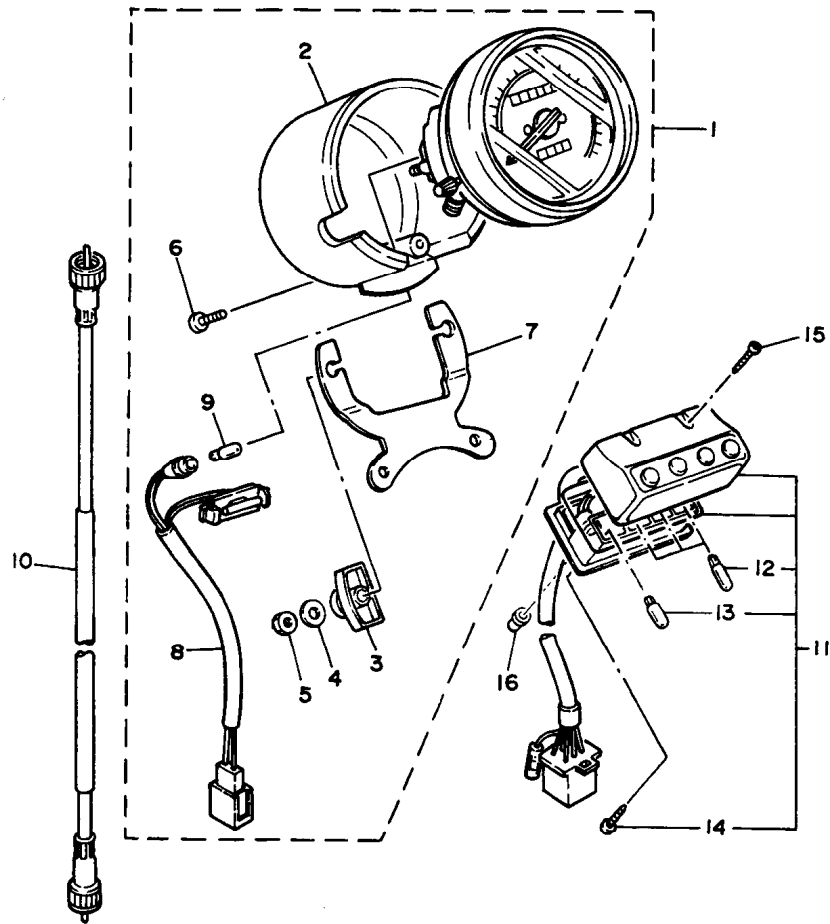

FIG. 49 ALTERNATE (METER)

REF. NO.	PART NO.	DESCRIPTION	Q'TY	REMARKS
1	3LS-83570-01	SPEEDOMETER ASSY	1	
2	2UJ-83507-00	.COVER, speedometer	1	
3	1FG-83523-00	.DAMPER	2	
4	90201-05725	.WASHER, plate	2	
5	95303-05600	.NUT	2	
6	90164-04009	.SCREW, tapping	1	
7	2GV-83519-00	.BRACKET, meter	1	
8	2UJ-83509-00	.SOCKET CORD ASSY	1	
9	42X-83517-00	.BULB (12V-3W)	1	
10	3Y0-83550-01	SPEEDOMETER CABLE ASSY	1	
11	3BT-83530-10	PILOT LIGHT ASSY	1	
12	42X-83517-00	.BULB (12V-3W)	2	
13	2GV-83517-00	.BULB (12V-1.7W, T6.5)	1	
14	4AS-84616-10	.SCREW, tapping	1	
15	98507-04035	SCREW, pan head	2	
16	90179-04579	NUT	2	

FWD

3DM010-8370

F9

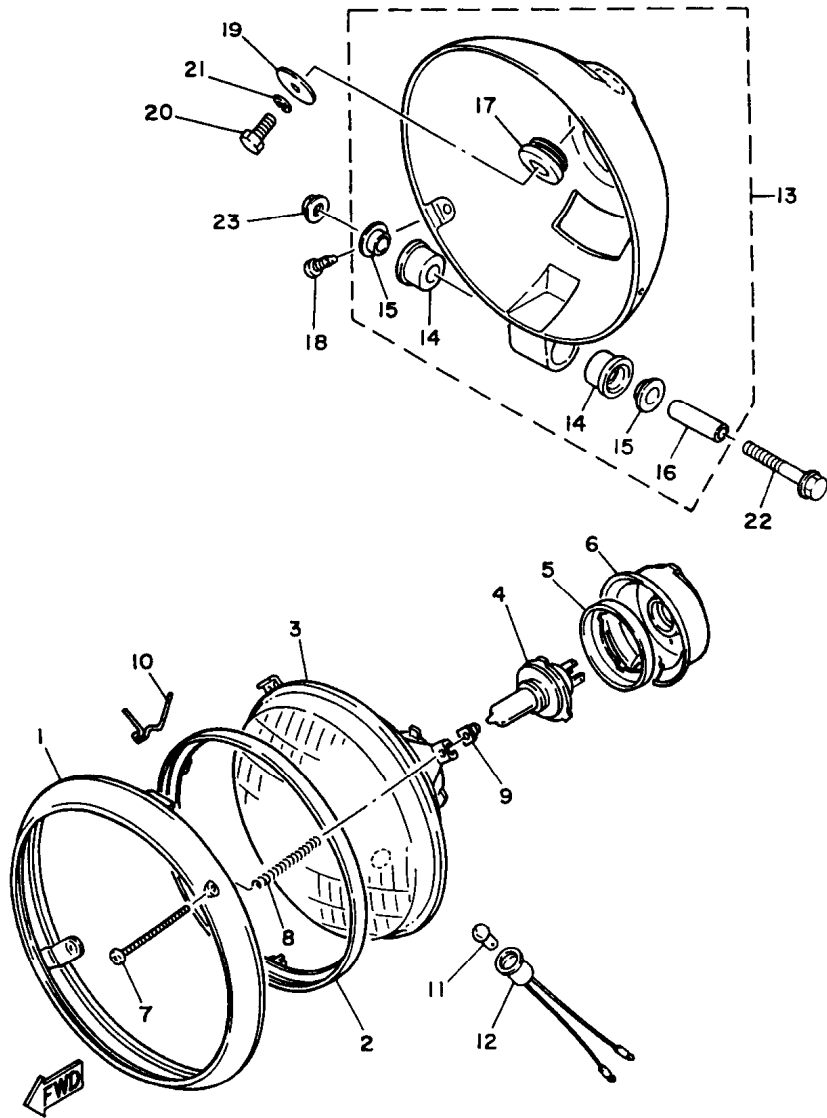

3DM010-8380

FIG. 50 ALTERNATE (HEADLIGHT)

REF. NO.	PART NO.	DESCRIPTION	Q'TY	REMARKS
1	42X-84315-01	RIM, headlight	1	
2	5Y3-84395-00	RING, retaining	1	
3	55R-84321-H0	LENS ASSY	1	
4	*	BULB (12V-60/55W)	1	LM HALOGEN
5	2F9-84375-00	FITTING PLATE, bulb	1	
6	2F9-84397-01	COVER, socket	1	
7	90157-04001	SCREW, pan head	2	
8	1A0-84332-60	SPRING, screw	2	
9	198-84334-60	NUT, adjusting	2	
10	42X-84124-60	SPRING, set	1	
11	123-83516-21	BULB	1	
12	34L-84346-00	SOCKET, pilot light	1	
13	42X-84330-01	BODY ASSY	1	
14	42X-84345-00	.DAMPER, headlight	2	
15	1FK-84338-00	.COLLAR, body fitting	2	
16	2UJ-84338-00	.COLLAR, body fitting	1	
17	42X-84366-00	.DAMPER, headlight 1	1	
18	90157-05084	SCREW, pan head	2	
19	90201-06073	WASHER, plate	1	
20	97007-06016	BOLT	1	
21	92907-06100	WASHER, spring	1	
22	95824-06045	BOLT, flange	1	
23	95704-06500	NUT, flange	1	

FOR BRAZIL

The following pages provides a listing of only the parts that meet the specifications peculiar to your market. For those parts not appearing in these pages, refer to the "GENERAL SPEC." section.

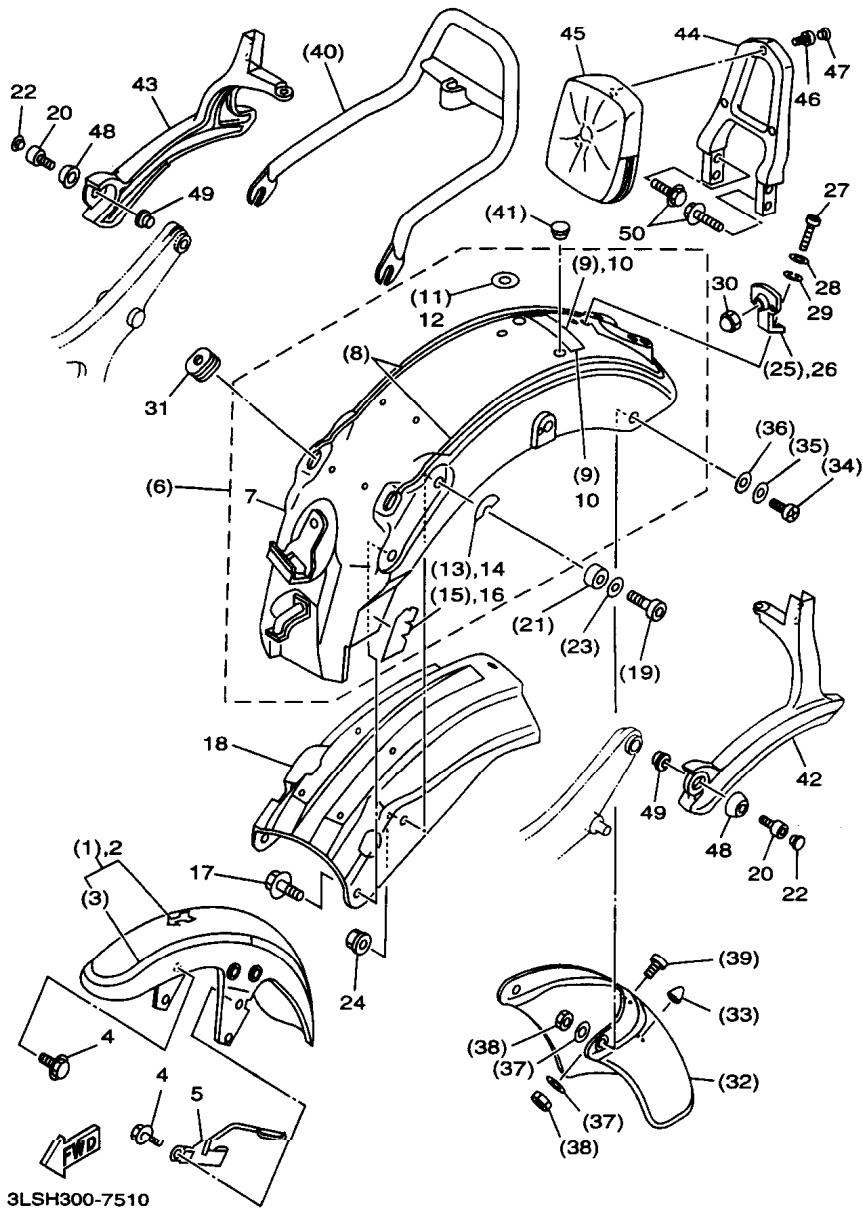

3LSH300-7510

FIG. 51 ALTERNATE (FENDER)

REF. NO.	PART NO.	DESCRIPTION	Q'TY	REMARKS
1	2UJ-Y2150-00-EG	FRONT FENDER COMP.	*	UR MAPLE RED
	2UJ-Y2150-10-7M	FRONT FENDER COMP.	*	UR MIDNIGHT SILVER
2	2UJ-21510-00-4B	FRONT FENDER COMP.	1	BLACK 2
3	3DM-21569-80	.GRAPHIC 1	*	UR FOR MPR
	3DM-21569-90	.GRAPHIC 1	*	UR FOR MDS
4	95024-08012	BOLT	4	
5	3DM-21597-00	HOLDER, wire 1	1	
6	3LS-Y2161-80-0X	REAR FENDER COMP.	*	UR MAPLE RED/SILKY GOLD
	3LS-Y2161-90-1X	REAR FENDER COMP.	*	UR MIDNIGHT SILVER/ BLACK 2
7	2UJ-21610-00-4B	REAR FENDER COMP.	1	BLACK 2
8	3DM-2165A-81	.GRAPHIC, rear fender	*	UR FOR MPR
	3DM-2165A-B0	.GRAPHIC, rear fender	*	UR FOR MDS
9	99237-00080	.EMBLEM, yamaha	*	
10	99236-00080	EMBLEM, yamaha	1	
11	2UJ-21735-00	.SEAL 2	*	
12	2UJ-21735-00	SEAL 2	1	
13	3DM-2173N-00	.SEAL 4	*	
14	3DM-2173N-00	SEAL 4	2	
15	2UJ-2173M-01	.SEAL 3	*	
16	2UJ-2173M-01	SEAL 3	1	
17	95817-10020	BOLT, flange	2	
18	2UJ-21670-00	REINF. COMP.	1	
19	92014-10050	BOLT, button head	*	
20	91314-10060	BOLT	2	
21	90387-100E2	COLLAR	*	
22	90338-10164	COLLAR	2	
23	92990-10200	WASHER, plane	*	
24	95707-10500	NUT, flange	2	

F12

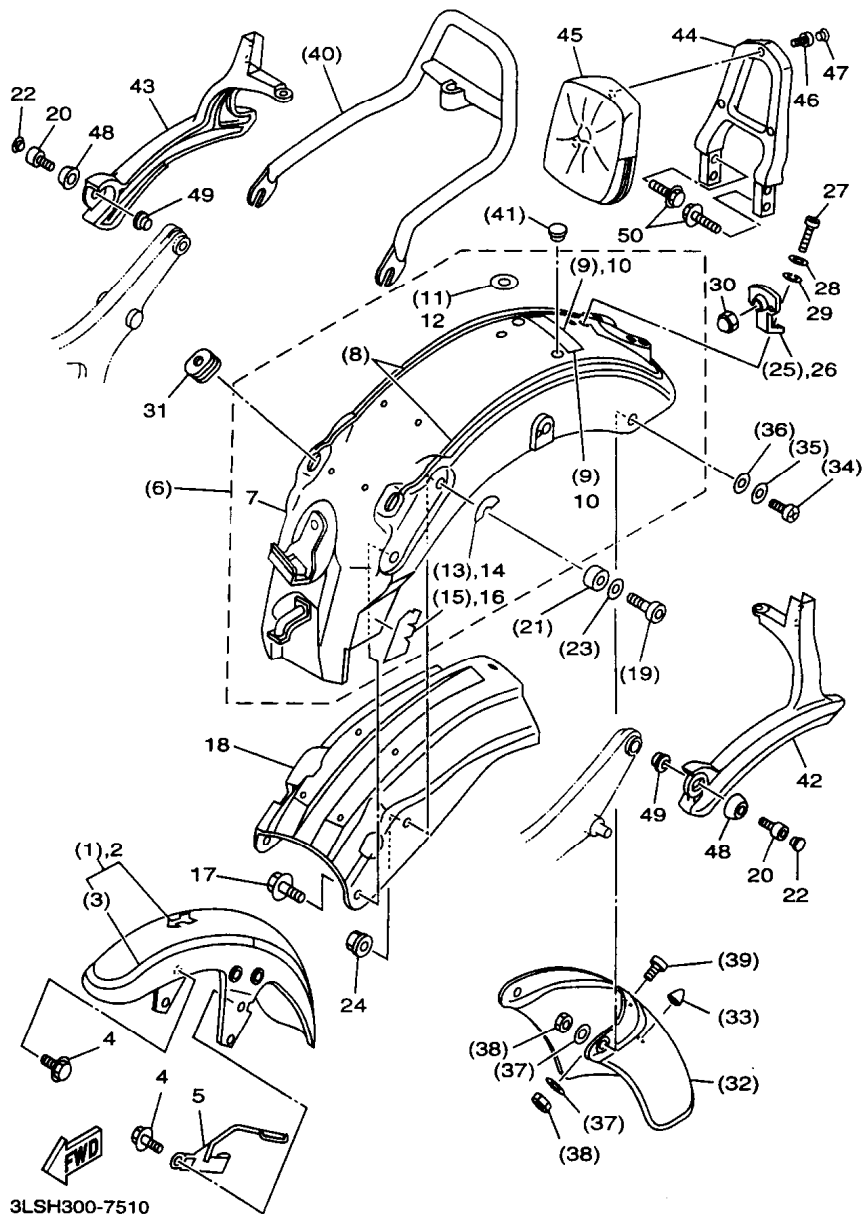

3LSH300-7510

FIG. 51 ALTERNATE (FENDER)

REF. NO.	PART NO.	DESCRIPTION	Q'TY	REMARKS
25	2UJ-21641-00	BRACKET, reflector	*	
26	4XT-F1641-00	BRACKET, reflector	1	
27	98507-05010	SCREW, pan head	1	
28	92907-05100	WASHER, spring	1	
29	92907-05600	WASHER, plate	1	
30	95307-05800	NUT, cap	1	
31	90480-01502	GROMMET	2	
32	3LS-21621-00	FLAP	*	
33	4G0-21639-00	DAMPER 2	*	
34	98517-06012	SCREW, pan head	*	
35	92907-06600	WASHER, plate	*	
36	90202-05187	WASHER, plate	*	
37	92907-06200	WASHER	*	
38	95317-06600	NUT	*	
39	98904-06014	SCREW, bind	*	
40	3LS-21640-00	REAR STAY COMP.	*	
41	1J3-24742-00	GROMMET	*	
42	3DM-2164F-00	STAY 1	1	
43	3DM-2164G-00	STAY 2	1	
44	3DM-2164H-00	STAY 3	1	
45	3DM-2840F-00	BACK REST	1	
46	91314-06025	BOLT	3	
47	90338-06162	PLUG	3	
48	3DM-22243-00	WASHER 1	2	
49	90387-126R2	COLLAR	2	
50	95024-06020	BOLT, flange	4	

* For convenience of reference:

Disregard the items asterisked (*) in the "QTY" column. These are intended for GENERAL SPEC, and NOT for INDIVIDUAL SPEC.

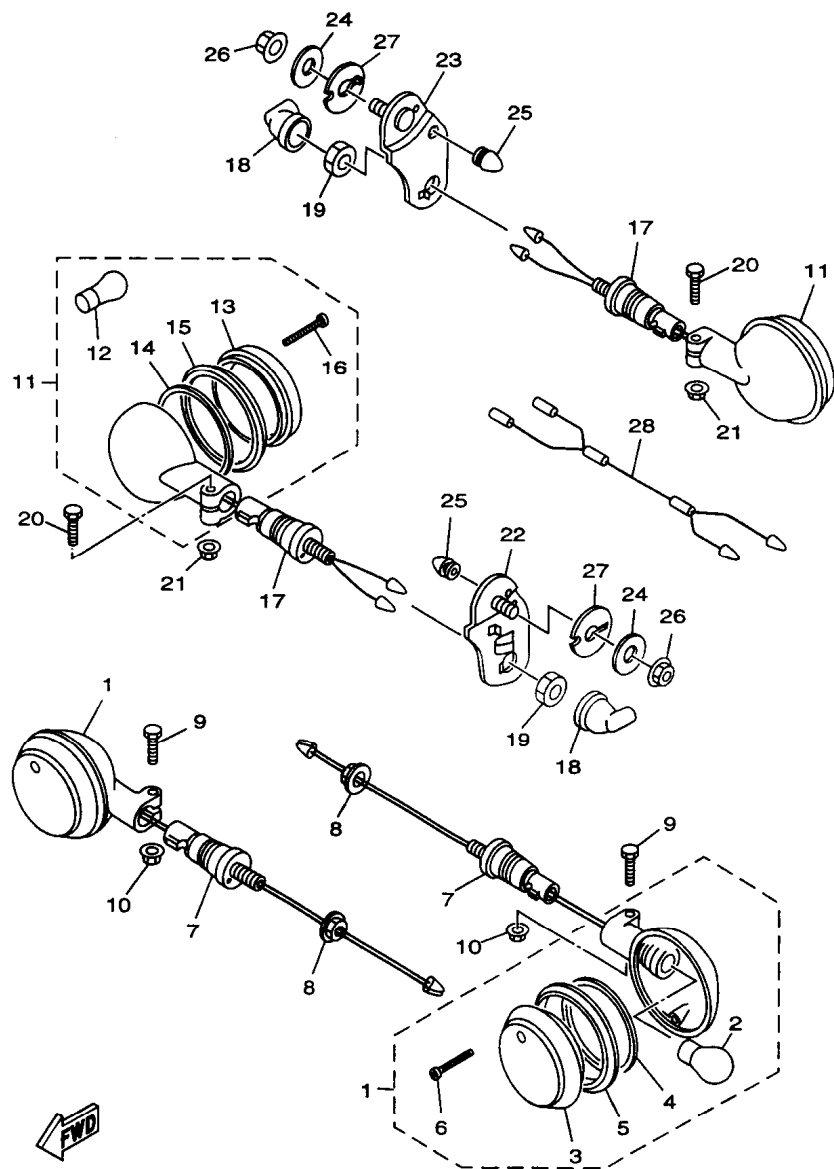

3LSH300-7520

FIG. 52 ALTERNATE (FLASHER LIGHT)

REF. NO.	PART NO.	DESCRIPTION	Q'TY	REMARKS
1	3LS-83310-00	FRONT FLASHER LIGHT ASSY 1	2	
2	1KT-83311-00	.BULB (12V-21W)	1	
3	42X-83312-00	.LENS, flasher	1	
4	42X-83313-00	.GASKET, flasher lens	1	
5	42X-83363-00	.LENS, rim	1	
6	57M-83358-00	.SCREW, special	2	
7	1AA-83318-00	STAY, flasher 1	2	
8	95304-12600	NUT	2	
9	97004-06030	BOLT	2	
10	95704-06500	NUT, flange	2	
11	3LS-83330-00	REAR FLASHER LIGHT ASSY 1	2	
12	1KT-83311-00	.BULB (12V-21W)	1	
13	2AE-83312-00	.LENS, flasher	1	
14	42X-83313-00	.GASKET, flasher lens	1	
15	42X-83363-00	.LENS, rim	1	
16	57M-83358-00	.SCREW, special	2	
17	1AA-83318-00	STAY, flasher 1	2	
18	18G-83365-00	CAP	2	
19	95304-12600	NUT	2	
20	97004-06030	BOLT	2	
21	95704-06500	NUT, flange	2	
22	3DM-83318-00	STAY, flasher	1	
23	3DM-83328-00	STAY, flasher	1	
24	90201-087G2	WASHER, plate	2	
25	4G0-21639-00	DAMPER	2	
26	95707-08500	NUT, flange	2	
27	3DM-21655-10	PATCH 1	2	
28	3TJ-82309-00	WIRE, sub lead	2	

F14

INDEX

(GENERAL SPEC.)

NUMERICAL INDEX

PART NO.	GRID NO.	PART NO.	GRID NO.	PART NO.	GRID NO.	PART NO.	GRID NO.	PART NO.	GRID NO.	PART NO.	GRID NO.
4XT-E4484-00	B-12	22F-11186-00	B- 2	2UJ-13586-00	B- 9	42H-14857-00	B-13	1W1-16358-01	C- 3	3DM-21569-80	C- 9
4XT-F1243-00	C- 8	214-11198-01	B-14	3BG-13595-00	B- 9	3BG-14858-00	B-13	30X-16371-00	C- 3	3DM-21569-90	C- 9
4XT-F1315-00	C- 8	2UJ-11310-01	B- 3	3DM-13910-00	D- 4	3BM-14867-00	B-13	2UJ-16380-00	C- 3	3DM-21597-00	C- 9
4XT-F1318-00	C- 8	3BG-11310-00	B- 3	2UJ-13978-00	B- 9	3BG-14871-00	B- 2	3Y1-17121-01	C- 5	3LS-21621-00	C- 9
4XT-F1319-00	C- 8	2UJ-11320-01	B- 3	3DM-1410A-10	B-10	3BG-14872-00	B- 2	3Y1-17131-01	C- 5	4GO-21639-00	C- 9
4XT-F135Y-00	C- 8	3BG-11320-00	B- 3	1HX-14103-00	B-11	3BG-14873-00	B-13	3Y1-17141-00	C- 5	3LS-21640-00	C-10
4XT-F3164-00	C-13	3DM-11351-00	B- 3	12R-14105-00	B-10	3BG-14874-00	B-13	3Y1-17151-00	C- 5	3LU-21640-00	C-10
4XT-F317F-00	C-13	2UJ-11400-00	B- 4	3CF-14107-10	B-10	1TA-14881-00	B-13	3Y1-17211-00	C- 5	2UJ-21641-00	C- 9
4XT-F317M-00	C-13	2UJ-11422-00	B- 4	3DM-14107-19	B-10	3BM-14882-00	B-12	3Y1-17221-01	C- 5	3DM-2165A-B0	C- 9
4XT-F3480-00	C-14	2UJ-11478-00	B- 4	2RJ-14118-00	B-10	3BM-14883-00	B-13	3Y1-17231-01	C- 5	3DM-2165A-81	C- 9
4XT-F3484-00	C-14	2UJ-1154A-00	B- 4	3F9-14118-00	B-10	3BG-14884-00	B-13	3Y1-17241-00	C- 5	2UJ-21670-00	C- 9
4XT-F4491-00	D- 4	50M-11610-00	B- 4	3DM-14141-30	B-11	3BG-14885-00	B-13	3Y1-17251-01	C- 5	2UJ-21711-00-EG	C-11
4XT-F4751-00	E- 6	50M-11610-20	B- 4	22F-14142-17	B-10	3BG-1490J-00	B-10	3Y1-17402-00	C- 5	2UJ-21711-00-4B	C-11
4XT-F5377-00	D- 8	50M-11610-40	B- 4	22F-14142-20	B-10	3DM-1490J-00	B-10	4DN-17411-00	C- 5	2UJ-21711-00-7M	C-11
4XT-F5872-00	D-11	2UJ-11631-00-A0	B- 4	1HX-14147-00	B-10	3DM-14900-10	B-10	3Y1-17456-00	C- 5	2N4-21717-00	C-11
4XT-F5886-00	D- 2	22K-11633-01	B- 4	137-14153-00	B-10	3LU-14900-10	B-10	3DM-17460-00	C- 5	2UJ-21721-00-EG	C-11
4XT-F7311-00	D-13	2UJ-11636-00	B- 4	353-14186-00	B-10	4XT-14900-00	B-10	2UJ-18101-01	C- 7	2UJ-21721-00-4B	C-11
4XT-F7315-00	D-14	2UJ-11638-00	B- 4	12R-14191-00	B-11	1HX-14933-00	B-10	2UJ-18110-00	C- 7	2UJ-21721-00-7M	C-11
4XT-F7430-00-35	D-13	2UJ-11651-00	B- 4	2LH-14197-00	B-11	3BG-14940-00	B-11	132-18113-01	C- 7	2UJ-2173M-01	C- 9
503-F7433-01	D-13	2UJ-11681-00	B- 4	1AE-14227-00	B-10	4XT-14940-00	B-11	2UJ-18115-02	C- 7	3DM-2173N-00	C- 9
	D-13	50M-12111-00	B- 5	620-1423A-73	B-10	1HX-14985-00	B-10	3Y1-18122-00	C- 6	2UJ-21735-00	C- 9
4XT-F7440-00-35	D-13	2UJ-12114-00	B- 5	1HX-14231-31	B-10	22F-14991-00	B-10	4GO-18127-00	C- 7	2UJ-21776-00	C-11
4XT-H2565-00	E-10	22F-12116-00	B- 5	620-14231-22-A0	B-10	256-14997-00	B-10	2UJ-18130-00	C- 7	3LS-22110-00-33	C-12
4XT-H2571-00	E-10	22F-12117-02	B- 5	1AE-14237-00	B-10	2UJ-15100-02	B-14	3Y1-18140-00	C- 7	55K-22129-00	C-12
23L-W0041-00	D-11	22F-12118-01	B- 5	1AE-14261-00	B-10	2UJ-15138-00	B-14	3Y1-18141-00	C- 6	2UJ-22141-01	C-12
4HM-W0045-00	D- 7	22F-12119-01	B- 5	2UJ-14401-00	B- 9	30X-15351-00	B- 7	2K7-18151-00	C- 6	55K-22151-01	C-12
4FU-W0047-50	D- 7	50M-12121-01	B- 5	2UJ-14419-00	B- 9	3Y1-15361-00	B-15	2H9-18154-00	C- 7	3DM-22210-00	C-12
51L-W0048-00	D- 7	50M-12151-00	B- 5	2UJ-14422-00	B- 9	1RG-15363-00	B-15		C- 7	447-22216-20	C-12
4FU-W0057-50	D- 7	22F-12156-00	B- 5	2UJ-14451-00	B- 9	3DM-15411-01	B-15	3Y1-18161-00	C- 6	447-22217-21	C-12
2UJ-W1141-00	B- 4	22F-12159-00	B- 5	2UJ-14452-00	B- 9	3DM-15421-00	B-15	3Y1-18185-01	C- 6	1UJ-22243-00	C-12
2UJ-W2341-00-35	C-13	2UJ-12171-00	B- 6	2UJ-14458-00	B- 9	3DM-15431-00	B-15	4DN-18511-00	C- 6	3LS-22311-00	C-12
3LS-W2536-00	D- 8	2UJ-12176-00	B- 6	2UJ-14469-00	B- 9	2UJ-15441-00	B-15	4DN-18512-00	C- 6	2UJ-23102-10	C-15
2UJ-Y2150-00-EG	C- 9	2UJ-12181-00	B- 6	2UJ-14484-00	B-12	3DM-15451-00	B-15	4DN-18513-00	C- 6	2UJ-23103-10	C-15
2UJ-Y2150-10-7M	C- 9	2UJ-12210-01	B- 6	2UJ-14485-00	B- 9	3DM-15461-00	B-15	4DN-18531-00	C- 6	2UJ-23110-00	C-15
3LS-Y2161-80-0X	C- 9	3DM-12213-00	B- 6	3DM-14504-01	B-11	2UJ-15512-00	C- 2	4DN-18535-00	C- 6		C-15
3LS-Y2161-90-1X	C- 9	2UJ-12231-00	B- 6	1FN-14565-00	B-10	2UJ-15517-00	C- 2	4DN-18540-00	C- 6	2JN-23111-00	C-15
2UJ-11102-00	B- 2	2UJ-12241-00	B- 6	1HX-14565-00	B-10	5HO-15521-00	C- 2	136-18542-00	C- 6		D- 2
3BG-11102-00	B- 2	2UJ-12279-00	B-14	2GV-14603-00	B-12	51Y-15590-01	C- 2	2K9-18561-00	C- 6	3J2-23114-00	C-15
2UJ-1111F-00	B- 6	2UJ-13300-00	B- 7	3DM-14613-00	B-12	3Y6-16111-03	C- 3	2UJ-21110-03-33	C- 8		D- 2
2UJ-11133-10	B- 2	3Y6-13326-01	B- 7	2UJ-14621-00	B-12	2UJ-16150-00	C- 3	3LS-21110-02-33	C- 8	58T-23118-L0	C-15
22F-11134-10	B- 2	2UJ-13341-00	B- 7	2UJ-14631-00	B-12	30X-16154-00	C- 3	2UJ-21243-00	C- 8		D- 2
2UJ-11142-00	B- 2	51Y-13411-00	B- 7	2GV-14663-00	B-12	31A-16321-01	C- 3	3DM-21287-00	E- 8	51Y-23125-00	C-15
2UJ-11152-00	B- 2	2XK-13416-00	B- 7	3DM-14703-11	B-12	3J2-16324-00	C- 3	26H-21308-00	C- 8		C-15
15A-11162-00	B- 3	4X7-13440-90	B- 8	3LU-14703-01	B-12	5Y1-16331-01	C- 3	2UJ-21315-00	C- 8	2UJ-23126-10	C-15
2UJ-11166-00	B-14	3DM-13447-00	B- 8	4FU-14714-00	B-12	3YX-1635A-00	C- 3	2UJ-21318-01	C- 8	2UJ-23136-10	C-15
2UJ-11181-01	B- 2	3VD-13455-00	B-14	42H-14714-10	B-13	30X-16351-01	C- 3	2UJ-21319-00	C- 8	2UJ-23141-00	C-15
2UJ-11185-01	B- 2	3BG-13542-00	B-13	42H-14808-00	B-13	4DN-16356-00	C- 3	2UJ-2135Y-00	C- 8		C-15
2UJ-11186-00	B- 2	1HX-13575-00	B- 9	3BG-14840-00	B-12	2UJ-16357-00	C- 4	3WF-2153E-40	C-13	51Y-23144-00	C-15

NUMERICAL INDEX

PART NO.	GRID NO.	PART NO.	GRID NO.	PART NO.	GRID NO.	PART NO.	GRID NO.	PART NO.	GRID NO.	PART NO.	GRID NO.
51Y-23144-00	C-15	2UJ-24312-01	D- 4	3DN-25872-00	D-11	3LS-81960-00	E- 8	42X-83517-00	E- 4	90109-067E6	E- 8
51Y-23145-00	C-15	2UJ-24313-00	D- 4	3DM-25886-10	D- 2	3BT-82103-00	E- 8		E- 4	90109-06799	E- 7
	C-15	2UJ-24491-01	D- 3	4BP-25919-00	D- 7	3DN-82110-00	E- 8	2GV-83519-00	E- 4	90109-081F0	D- 7
3DM-23149-10	C-15	2UJ-24500-00	D- 3	3YX-25929-00	D- 7	2UJ-82115-00	E- 8	1FG-83523-00	E- 4	90109-081G5	D- 9
	D- 2	3H3-24523-00	D- 3	3YX-25937-00	D- 7	2UJ-82116-00	E- 8	3BT-83530-10	E- 4	90109-081G6	D- 9
509-23151-L0	C-15	1JK-24534-00	D- 3	5R2-25937-00	D- 7	118-82131-00	E- 8	3Y0-83550-01	E- 4	90109-10474	D-13
	C-15	2UJ-24544-01	D- 3	2UJ-26111-01	D-10	26H-82131-00	C-11	3DM-83570-01	E- 4	90116-06228	B- 2
22W-23153-L0	C-15	2UJ-24560-00	D- 3	1FW-2622F-01	D-10	2UJ-82150-02	E- 8	3BT-83790-00	E- 8	90116-10485	D- 8
	C-15	4X7-24602-04	D- 4	2UJ-26240-00	D-10	1E6-82151-00	E- 8	2GV-83912-00	E- 7	90116-10519	D-12
509-23158-L0	C-15	4X7-24612-00	D- 4	21A-26241-00	D-10	148-82151-00	E- 8	2W1-83922-00	E- 7	90119-05062	C-12
	D- 2	2UJ-2471A-00	D- 5	42N-26246-00	D-10	3LS-82305-00	E- 8	437-83936-01	E- 7	90119-06108	C-11
3DM-23164-00	C-13	3DM-24710-10	D- 5	1J7-26290-F0	D-10	2UJ-82310-00	E-10	437-83936-11	E-10	90119-06182	E- 6
2UJ-2317E-00	C-13	18A-24724-00	D- 5	1J7-26290-G0	D-10	2UJ-82320-00	E-10	10M-83941-00	E- 7	90123-08046	D-10
3DM-2317F-00	C-13	509-24724-00	D- 5	2UJ-26311-01	D-10	1UY-82370-20	E-10	10M-83942-00	E- 7	90149-06011	D- 3
2UJ-2317M-00	C-13	3DM-24731-10	D- 5	2UJ-26312-01	D-10	2UJ-82509-00	E- 8	3DM-83972-00	E- 7	90149-06131	E- 7
2UJ-23170-00	C-15	1J3-24742-00	C-10	2UJ-26331-01	D-10	3DM-82510-00	E-10	3DM-83973-10	E- 7	90149-06154	C- 8
	C-15	2UJ-2475H-00	D- 5	2UJ-26335-01	D-10	3XV-82530-01	E-10	2UJ-83980-00	E-10	90149-06228	E-10
39K-23173-00	C-15	3LS-24750-10	D- 5	1E6-26342-00	D-10	4KM-82540-00	E-10	42X-84124-60	E- 5	90149-08067	C- 3
	C-15	3DM-24751-10	D- 5	2UJ-26351-00	D-12	3BT-82560-00	E-10	42X-84315-01	E- 5	90153-06008	D-13
2UJ-23174-00	C-13	3DM-25104-00	D- 6	5H0-26393-00	D-10	2UJ-82565-00	E-10	2AE-84320-G0	E- 5	90153-06029	B-14
278-23181-50	C-15	4DN-25111-20-35	D- 6	2UJ-27211-01	D-12	3LD-82566-60	E-10	42X-84330-01	E- 5	90153-06042	B-15
	D- 2	322-25118-00	D- 6	2UJ-27216-00	D-12	3BG-82571-00	E-10	1A0-84332-60	E- 5	90157-04001	E- 5
3LS-23340-00	D- 2	4DN-25190-01	D- 6	2UJ-27262-02	D-12	3DM-82571-00	E-10	198-84334-60	E- 5	90157-05079	E-10
2UJ-23346-00	D- 2	2UJ-25304-00	D- 8	2UJ-27311-01	D-13	3LS-82590-20	E- 8	1FK-84338-00	E- 5	90157-05084	E- 5
156-23411-00	D- 2	2UJ-25311-10	D- 8	2KT-27315-00	D-13	12R-82591-00	E- 8	2UJ-84338-00	E- 5	90159-06016	C- 3
183-23411-00	C-13	2UJ-25317-00	D- 8	2UJ-27316-00	D-14	10M-82911-00	E- 7	42X-84345-00	E- 5	90163-04003	B-12
156-23412-00	C-13	2RH-25321-10	D- 8	2UJ-2741L-00-33	D-13	2UJ-82917-00	E- 7	34L-84346-00	E- 5	90164-04009	E- 4
183-23412-00	C-13	3Y6-2533A-01	D- 8	2UJ-27410-00	D-12	3LS-83310-00	E- 3	4E2-84347-00	E- 5	90170-05302	B- 5
136-23415-00	C-13	2RH-25351-00	D- 8	4X7-27413-00	D-12	1KT-83311-00	E- 3	42X-84366-00	E- 5	90170-06010	E- 7
5A8-23434-01	C-13	5H0-25355-00	D- 8		D-12		E- 3	2F9-84375-00	E- 5	90170-06228	C- 7
4H7-23441-00-38	C-13	5Y1-25364-00	D- 8	2UJ-27414-00	D-12	2AE-83312-00	E- 3	5Y3-84395-00	E- 5	90170-16311	C- 3
42X-23442-00-38	C-13	5Y1-25366-10	D- 8	4X7-27417-00	D-12	42X-83312-00	E- 3	2F9-84397-01	E- 5	90170-16326	C- 3
164-23462-00	D- 2	2UJ-25371-00	D- 9		D-12	42X-83313-00	E- 3	4AS-84616-10	E- 4	90171-14056	D- 9
134-23484-10	C-14	2UJ-25377-00	D- 8	2UJ-2742L-00-33	D-13		E- 3	3LS-84700-00	E- 6	90175-05005	B- 9
2UJ-24110-00-W3	D- 3	10W-25381-00	D- 6	2UJ-27420-00	D-12	1AA-83318-00	E- 3	2UJ-84704-00	E- 6	90179-04579	E- 4
3DM-24110-00-X7	D- 3	2UJ-25381-00	D- 8	2UJ-27430-00-33	D-13		E- 3	31L-84714-00	E- 6	90179-06403	D-10
3DM-24110-00-09	D- 3	2UJ-25383-00	D- 9	120-27433-00	D-13	3LS-83330-00	E- 3	3LS-84721-00	E- 6	90179-06411	D-12
3LW-24161-00	D- 3	2UJ-25388-00	D- 9		D-13	3LU-83330-00	E- 3	2UJ-84723-00	E- 6	90179-06668	B-12
3LW-24161-40	D- 3	55K-2539F-00	D- 9	2UJ-27440-00-33	D-13	3GM-83350-01	E- 9	3LS-84751-00	E- 6	90179-08148	D-10
3LW-24161-70	D- 3	156-25398-00	D- 6	2UJ-28100-00	C- 8	57M-83358-00	E- 3	3Y6-85130-02	E-10	90179-08656	C- 8
3LW-24162-00	D- 3		D- 8	3DM-81410-20	D-15		E- 3	90101-06576	B-12	90179-12248	B- 4
3LW-24162-40	D- 3	4DN-25445-20	D- 8	3DM-81450-20	D-15	42X-83363-00	E- 3	90101-06765	D- 8	90179-25033	C-13
3LW-24162-70	D- 3	4HM-2580T-00	D- 7	2UJ-81800-03	E- 2		E- 3	90101-08590	B- 6	90183-04027	B-12
4H7-24181-00	D- 3	3LP-2582T-00	D- 7	50M-81801-M0	E- 2	18G-83365-00	E- 3	90105-08324	B- 2	90185-10037	D-13
2UJ-24182-00	D- 3	4H7-25852-00	D-11	59V-81828-M0	E- 2	3BN-83371-00	E-10	90105-10638	D- 7	90185-12164	C-12
42X-24183-00	D- 3	4L0-25854-00	D-11	2UJ-8183G-00	E- 2	2UJ-83507-00	E- 4	90105-14102	C-13	90201-05036	B- 9
3DM-24240-80	D- 3	4L0-25867-00	D-11	36Y-81940-00	E- 8	2UJ-83509-00	E- 4	90109-06470	D-12	90201-05725	E- 4
3DM-24240-80	D- 3	2UJ-25870-00	D-11	2UJ-81950-00	E- 8	2GV-83517-00	E- 4	90109-06577	E- 7	90201-06073	E- 5

NUMERICAL INDEX

PART NO.	GRID NO.	PART NO.	GRID NO.	PART NO.	GRID NO.	PART NO.	GRID NO.	PART NO.	GRID NO.	PART NO.	GRID NO.
90201-065F3	C-12	90387-066M3	B- 2	90560-15240	D- 6	92907-06600	B- 9	93440-34025	C- 6	95617-10100	C-13
90201-06697	B- 2	90387-07391	B-12	91311-08035	D- 2		B-14	93450-14088	B- 4	95704-06500	E- 3
90201-080L7	B- 2	90387-100E2	C- 9	91314-06016	B- 6		C-10	93501-04011	C-13		E- 3
90201-08087	C- 3	90387-100V6	D-12	91314-06020	E- 2		D- 4	93511-32027	C- 4		E- 5
90201-08326	B- 6	90387-12787	C- 7	91314-06075	D-10		D-11	93603-12030	B- 7	95707-06500	D- 5
90201-085R5	E- 8	90387-153U1	D- 9	91314-08025	C-13		E- 8	93604-18100	C- 6		E- 8
90201-08569	D- 3	90387-15600	D- 6	91317-05010	D- 4	92907-08100	D- 3	93604-29151	C- 6		E- 8
90201-08762	C-12	90401-10159	D-11	91317-06012	B- 6	92990-06100	E- 6	94113-154W1	D- 8	95707-10500	C- 9
90201-100A1	D-12	90413-07007	B- 9	91317-06016	C-13	92990-06600	B-12	94130-185T4	D- 6	95807-06010	B-12
90201-10118	D-11	90430-06014	B-14	91317-06020	B- 9	92990-08100	D- 9	94213-15265	D- 8		E- 8
90201-10119	B- 7	90430-10148	E-10	91317-06025	B- 9	92990-08600	D- 9	94227-18195	D- 6		E-10
90201-105A2	C-13	90445-08248	E- 8	91317-06040	B- 2	92990-10200	C- 9	94313-15154	D- 8		E-10
90201-10742	D-13	90445-11501	D- 4	91317-06110	B- 2	93101-14089	B-15	94345-18081	D- 6	95807-06016	D- 5
90201-12191	B- 4	90445-117F0	B- 9	91317-08018	C- 2	93101-17093	C- 5	94416-18523	D- 6	95807-06020	B-12
90201-124E4	C- 7	90445-11754	D- 4	91401-20015	D- 9	93102-12106	C- 7	94427-15476	D- 8	95807-06025	B-12
90201-17255	C- 7	90445-11763	B- 9		D-12	93102-14209	C- 3	94580-25110	B- 6		B-12
90201-20W42	D-13	90460-54111	B- 9		D-13	93102-20281	D- 6	94581-18114	D- 8	95807-08012	B-12
	D-13	90460-54137	B- 9		D-13	93102-25208	C- 5	94701-00282	B- 2	95807-10014	B-12
90201-20276	C- 5	90461-06087	B-11	91401-25020	D-12	93106-30029	D- 8	94701-00283	B- 2	95814-08110	C- 8
90201-20279	D-13	90464-16119	E- 9		D-12	93109-18020	C-12	95024-06010	D- 3	95814-08150	C- 8
	D-13	90465-06322	B-15	91401-30030	D- 9	93210-06245	B- 7		D- 3	95817-08016	C- 8
90201-22793	C- 5	90465-08158	B-14	91701-06018	D-12	93210-10096	B- 7		D- 4	95817-08035	B-12
90201-25291	C- 2	90465-08277	B-14	91701-06032	D-13	93210-11368	E- 7	95024-06012	C-13	95817-10020	C- 9
90201-253K0	C- 5	90467-08092	B-13		D-13	93210-14369	B-15	95024-06016	C-13	95824-06045	E- 5
90202-05057	B-13	90467-10008	B- 9	91701-08038	D-12	93210-19123	B-15	95024-06020	B- 2	97004-06014	E- 6
90202-05187	C-10		D- 4		D-12	93210-25711	E- 2	95024-08012	C- 9	97004-06030	E- 3
	D- 3		D- 4	92014-08035	D- 5	93210-30611	B- 9		C-12		E- 3
90208-04029	C-14	90467-11106	B- 9	92014-10050	C- 9	93210-32172	B-15	95024-08020	D-13	97007-05020	E-10
90209-06223	C-12	90467-14015	B-14	92901-06200	E- 7	93210-35389	B- 7	95024-08025	D- 5	97007-06016	E- 5
90209-10131	E- 7	90467-26111	B-12	92901-06600	E- 6	93210-44704	B- 2	95024-08040	C-13	97007-06025	D-11
90209-22191	C- 5	90468-08104	B-13	92903-12200	C-12	93210-53679	B- 3	95027-06012	D- 5		E- 7
90209-31300	B- 4	90480-01502	C- 9	92903-14200	D- 9	93210-55669	E- 2		D-10	97007-08035	D- 3
90215-16156	C- 3	90480-13018	B- 2	92907-05100	C- 9	93210-64297	B- 8	95303-05600	E- 4	97024-06020	C- 7
90215-16222	C- 3	90480-13428	C-11		D-15	93210-78544	B- 2	95304-06600	D- 8	97027-06010	C- 5
90215-16320	C- 3	90480-14229	E- 6	92907-05200	B-13	93306-00302	C- 5	95304-06700	C- 7	97027-06012	B- 6
90249-12008	D-12	90480-16501	E- 6	92907-05600	C- 9	93306-00426	C- 5	95304-08600	D- 9		B-14
90269-04003	C-14	90480-22362	C-11	92907-06100	D- 4	93306-20209	D- 6	95304-08700	D- 9	97704-40012	B-12
90280-16053	B- 4	90501-10245	D-12		D-12	93306-20226	D- 8	95304-12600	E- 3	97707-40525	E- 6
90282-07023	C- 3	90501-10312	E- 7		D-15	93306-20541	C- 5		E- 3	97707-60114	B-13
90338-08163	C-13	90501-18576	B- 7		E- 5	93306-30416	D- 8	95307-05600	B-13	98503-03008	D- 3
90338-10132	B-13	90501-26148	C- 3		E- 7	93306-30525	C- 5	95307-05800	C- 9	98503-04014	B-11
90340-14068	B-15	90506-15260	D- 8		E- 8	93306-30615	B- 4	95307-06600	C- 3	98504-06025	B- 8
90340-32088	B-15	90508-12430	C- 6		E- 8	93315-23612	C- 6		D-13		B-15
90380-12121	C-12	90508-14433	C- 3	92907-06200	C- 3	93315-31428	C- 3	95317-06600	C-10		B-15
90381-22070	B- 6	90508-20023	D-12		C-10	93410-22039	C- 5	95380-10800	D-13		B-15
90385-10026	B-12		D-12		D-12	93420-28055	C- 3	95604-10200	D- 8	98504-06030	B-14
90386-18163	C-12	90508-26434	C- 7	92907-06600	B- 6	93440-10109	B- 2	95607-06100	E- 7		B-14
90387-061V1	E- 6	90508-32374	C- 7		B- 9	93440-25084	C- 5		E- 7	98504-06035	B-15

NUMERICAL INDEX

PART NO.	GRID NO.	PART NO.	GRID NO.	PART NO.	GRID NO.	PART NO.	GRID NO.	PART NO.	GRID NO.	PART NO.	GRID NO.
98504-06035	B-15	99510-10114	B-14								
98504-06040	B-14	99510-12016	B-14								
98504-06050	B-15		B-15								
98504-06070	B-14		B-15								
	B-15										
98504-06080	B-14										
98504-06090	B- 8										
98506-05035	E- 7										
98506-05040	E- 7										
98506-05045	E- 7										
98506-06008	E- 7										
98507-04035	E- 4										
98507-05008	D-10										
98507-05010	C- 9										
98507-05016	D-15										
98507-06010	B-15										
	D- 2										
	E- 8										
98507-06012	C- 8										
	D- 4										
98507-06016	E- 8										
98507-06025	B- 2										
	B- 7										
98507-06040	B- 9										
98507-06060	B-14										
98507-06070	B-14										
98507-06080	B-14										
98511-04012	B-11										
98517-06012	C-10										
98517-06030	D-15										
98707-04012	D-11										
98707-05035	C- 6										
98707-06025	B- 7										
98904-06012	C-12										
98904-06014	C-10										
99009-10400	B- 7										
	C- 6										
99009-12400	C- 7										
99009-17400	C- 7										
99009-20400	C- 5										
99009-25400	C- 5										
99009-25500	B-15										
99080-07600	C- 6										
99234-00080	C-11										
99235-00080	C-11										
99236-00080	C-11										
99237-00080	C- 9										
99510-10114	B- 2										

INDEX

(INDIVIDUAL SPEC.)

NUMERICAL INDEX

PART NO.	GRID NO.	PART NO.	GRID NO.	PART NO.	GRID NO.	PART NO.	GRID NO.	PART NO.	GRID NO.	PART NO.	GRID NO.
4XT-F1641-00	F-13	2UJ-24734-00	F- 2	1FK-84338-00	F-10	95704-06500	F-10				
2UJ-Y2161-00-6X	E-15		F- 5	2UJ-84338-00	F-10		F-14				
	F- 4		F- 8	42X-84345-00	F-10		F-14				
	F- 7	47X-24739-00	F- 2	34L-84346-00	F-10	95707-06500	F- 2				
2UJ-Y2161-20-7X	E-15		F- 5	42X-84366-00	F-10		F- 5				
	F- 4		F- 8	2F9-84375-00	F-10		F- 8				
	F- 7	3DM-24750-10	F- 2	5Y3-84395-00	F-10	95707-08500	F-14				
2UJ-21510-00-4B	F-12		F- 5	2F9-84397-01	F-10	95707-10500	F-12				
3DM-21597-00	F-12		F- 8	4AS-84616-10	F- 9	95817-10020	F-12				
2UJ-21610-00-4B	F-12	3DM-24751-10	F- 2	90157-04001	F-10	95824-06045	F-10				
4G0-21639-00	F-14		F- 5	90157-05084	F-10	97004-06030	F-14				
3DM-2164F-00	F-13		F- 8	90164-04009	F- 9		F-14				
3DM-2164G-00	F-13	3DM-2840F-00	F-13	90173-06015	F- 2	97007-06016	F-10				
3DM-2164H-00	F-13	3TJ-82309-00	F-14		F- 5	98507-04035	F- 9				
3DM-2165A-B0	E-15	3LS-83310-00	F-14		F- 8	98507-05010	F-13				
	F- 4	1KT-83311-00	F-14	90179-04579	F- 9	99236-00080	F-12				
	F- 7		F-14	90201-05725	F- 9	99237-00080	E-15				
3DM-2165A-81	E-15	2AE-83312-00	F-14	90201-06073	F-10		F- 4				
	F- 4	42X-83312-00	F-14	90201-08762	F-14		F- 7				
	F- 7	42X-83313-00	F-14	90338-06162	F-13						
3DM-21655-10	F-14		F-14	90338-10164	F-12						
2UJ-21670-00	F-12	1AA-83318-00	F-14	90387-126R2	F-13						
2UJ-2173M-01	E-15		F-14	90468-10050	F- 2						
	F- 4	3DM-83318-00	F-14		F- 5						
	F- 7	3DM-83328-00	F-14		F- 8						
	F-12	3LS-83330-00	F-14	90480-01502	F-13						
3DM-2173N-00	E-15	57M-83358-00	F-14	90502-09024	E-12						
	F- 4		F-14		E-14						
	F- 7	42X-83363-00	F-14	91314-06025	F-13						
	F-12		F-14	91314-10060	F-12						
2UJ-21735-00	E-15	18G-83365-00	F-14	91317-10035	E-15						
	F- 4	2UJ-83507-00	F- 9		F- 4						
	F- 7	2UJ-83509-00	F- 9		F- 7						
	F-12	123-83516-21	F-10	92907-05100	F-13						
3DM-22243-00	F-13	2GV-83517-00	F- 9	92907-05600	F-13						
2A6-23408-00	E-12	42X-83517-00	F- 9	92907-06100	F-10						
	E-14		F- 9	92907-10600	E-15						
3DM-23484-00	E-12	2GV-83519-00	F- 9		F- 4						
	E-14	1FG-83523-00	F- 9		F- 7						
2UJ-2471A-00	F- 2	3BT-83530-10	F- 9	95024-06020	F-13						
	F- 5	3Y0-83550-01	F- 9	95024-08012	F- 2						
	F- 8	3LS-83570-01	F- 9		F- 5						
1WG-24712-00	F- 2	42X-84124-60	F-10		F- 8						
	F- 5	42X-84315-01	F-10		F-12						
	F- 8	55R-84321-H0	F-10	95303-05600	F- 9						
509-24724-00	F- 2	42X-84330-01	F-10	95304-12600	F-14						
	F- 5	1A0-84332-60	F-10		F-14						
	F- 8	198-84334-60	F-10	95307-05800	F-13						

*COPYRIGHT: All rights reserved. No part of this publication
may be reproduced without permission.*

YAMAHA

YAMAHA MOTOR CO., LTD.

2500 SHINGAI IWATA SHIZUOKA JAPAN
SERVICE INFORMATION DIV.

PRINTED ON RECYCLED PAPER

Printed in Japan
First edition JUL.,1996