

YAMAHA

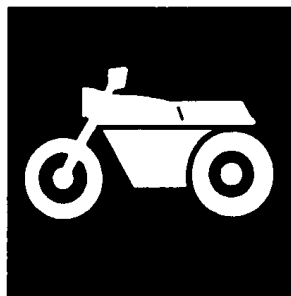

**PARTS
CATALOGUE**

XVZ1300A'99 (4YP3) EUROPE

YAMAHA
GENUINE
Parts & Accessories

194YP-300E1

FOREWORD

This Parts Catalogue is related to the parts for the model(s) in the below frame. When you are ordering replacement parts, please refer to this Parts Catalogue and quote both part numbers and part names correctly.

XVZ1300A'99(4YP3)

1. Modifications or additions which have been made after issue of the Parts Catalogue will be announced in the Yamaha Parts News. It is advisable that you make necessary corrections to the Parts Catalogue according to the Yamaha Parts News.
2. Abbreviations
The Following abbreviations are used in this Parts Catalogue.
 "UR" Use specified parts number.
 "UN" Use as many as needed.
 "AP" Alternate Parts
 "LM" Local Made (Parts need to be ordered locally)
 "F#" Frame No. (Applicable machine No.)
3. Parts, which are to be supplied in an assembly, are listed with a dot(.) in front of the part name as shown below.
 EXAMPLE
 CARBURETOR ASSY
 .JET, PILOT
 .NOZZLE, MAIN
4. Number of component for assembly
The numeral appearing to the right of each component part indicates the quantity of parts for each assembly unit.

EXAMPLE

PART NO.	DESCRIPTION	Q'TY	REMARKS
2F5-83310-60	FRONT FLASHER LIGHT ASSY	2	
115-83311-60	.BULB (6V-18W)	1	
1M1-83309-60	.REFLECTOR	1	

5. Applicable colors of graphics are represented in the "REMARKS" as shown below.

PART NO.	DESCRIPTION	Q'TY	REMARKS
2N4-24110-00-X5	.FUEL TANK COMP.	2	MXR
3J1-24240-10	.GRAPHIC, FUEL TANK	1	for MXR

6. Applicable Serial No.

① Engine Serial No.

② Frame Serial No.

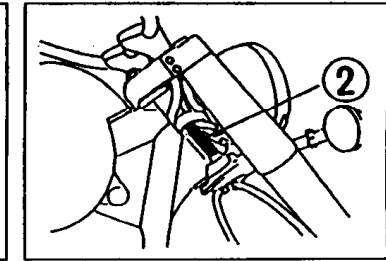
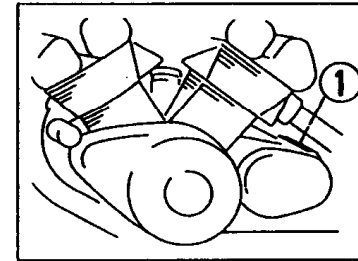

7. Note that the illustrations for reference in funding parts numbers, not to be used for assembling. When assembling, pleas use the applicable service manual.
8. The asterisk (*) before a reference number indicates modification items after the first edition.

MODEL LABEL

(1) A label called "Model Label" is affixed in the location as indicated in (3) below. When using this parts catalogue, please be sure to cross-refer the "model code - production code No." in the catalogue to the "model code - production code No." indicated on the Model Label affixed onto the product concerned.

(2) "Model Label" Indication

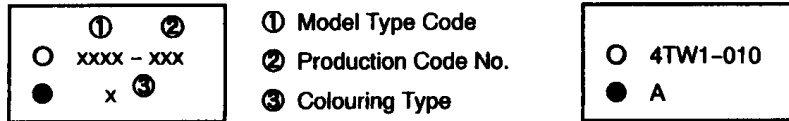

(3) Model Label Affixing Location

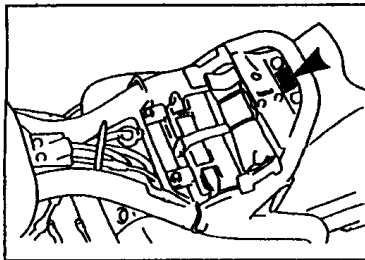

(4) Model Code - Production Code Number of Model Listed in This Parts Catalog

Model Code	Production Code No.	Country (destination)	Model Code	Production Code No.	Country (destination)
4YP3	020	BELGIUM			
	030	DENMARK			
	040	SPAIN			
	050	FINLAND			
	070	ENGLAND			
	080	GREECE			
	090	ITALY			
	100	HOLLAND			
	110	NORWAY			
	120	PORTUGAL			
	130	SWEDEN			

(5) Colouring Information

Colouring type code	Colour code	Colour Name	Abbreviation
A	0033	YAMAHA BLACK	YB
B	00FW	BRIGHT CHERRY RED	BCR

CONTENTS

ENGINE

CYLINDER HEAD	B2
CRANKSHAFT. PISTON	B5
VALVE	B7
CAMSHAFT. CHAIN	B9
WATER PUMP	B10
RADIATOR. HOSE	B12
OIL PUMP	B15
OIL CLEANER	C2
INTAKE	C4
CARBURETOR	C5
EXHAUST	C8
CRANKCASE	C9
CRANKCASE COVER 1	C11
STARTER CLUTCH	C13
CLUTCH	C14
TRANSMISSION	D2
MIDDLE DRIVE GEAR	D3
SHIFT CAM. FORK	D5
SHIFT SHAFT	D6

CHASSIS

FRAME	D8
FENDER	D10
SIDE COVER	D12
REAR ARM	D14
DRIVE SHAFT	D15
REAR SUSPENSION	E3
STEERING	E4
FRONT FORK	E5
FUEL TANK	E8
SEAT	E10
FRONT WHEEL	E11

FRONT BRAKE CALIPER	E12
REAR WHEEL	E13
REAR BRAKE CALIPER	E14
STEERING HANDLE. CABLE	E15
FRONT MASTER CYLINDER	F2
FRONT MASTER CYLINDER 2	F3
STAND. FOOTREST	F4
REAR MASTER CYLINDER	F6
GENERATOR	F8
STARTING MOTOR	F9
FLASHER LIGHT	F10
METER	F11
HEADLIGHT	F12
TAILLIGHT	F13
HANDLE SWITCH. LEVER	F14
ELECTRICAL 1	F15
ELECTRICAL 2	G3

INDEX

NUMERICAL INDEX	M1
-----------------------	----

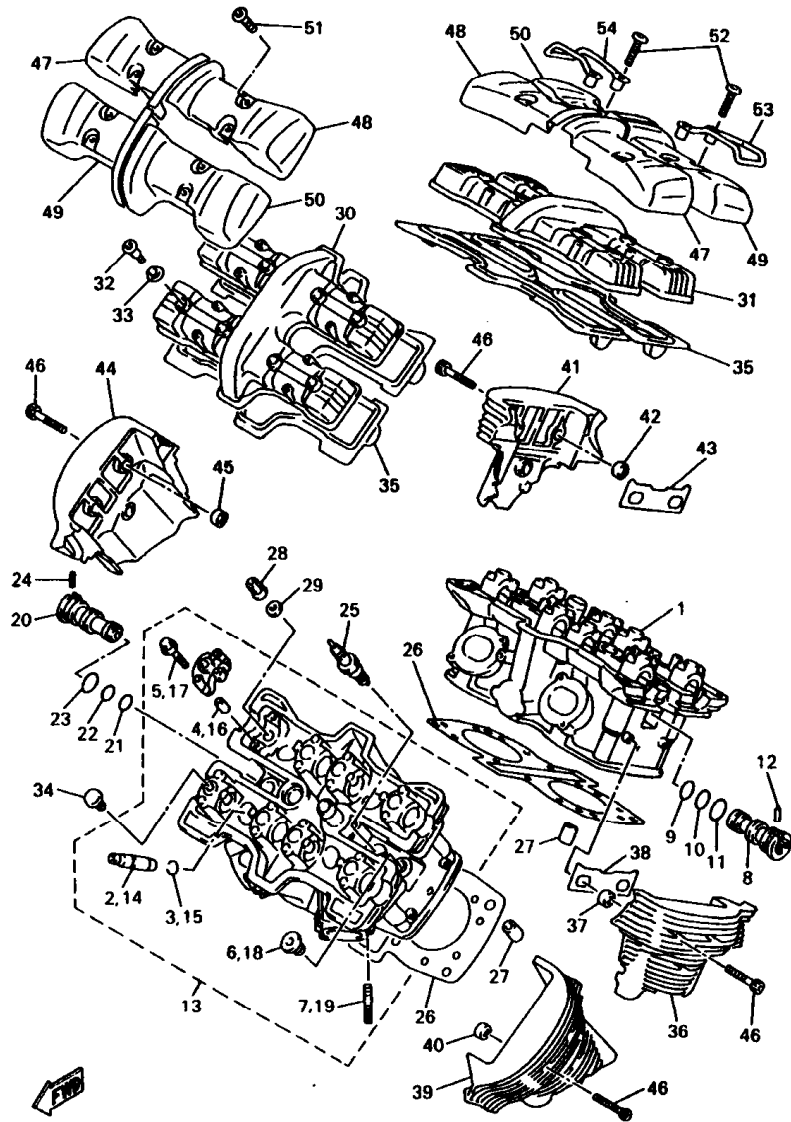

4NK110-6010

FIG. 1 CYLINDER HEAD

REF. NO.	PART NO.	DESCRIPTION	4YP3			REMARKS
1	4NK-11110-00	CYLINDER HEAD ASSY	1			
2	26H-11133-10	.GUIDE, INTAKE VALVE	8			
3	93440-12117	.CIRCLIP	8			
4	91808-18023	.PIN, DOWEL	16			
5	90105-06153	.BOLT, WASHER BASED	16			
6	90340-18101	.PLUG, STRAIGHT SCREW	3			
7	95617-08620	.BOLT, STUD	4			
8	26H-12469-01	JOINT 1	1			
9	93210-18629	O-RING	1			
10	93210-18322	O-RING	1			
11	93210-21631	O-RING	1			
12	90254-03008	PIN, SPRING	1			
13	4NK-11120-00	CYLINDER HEAD ASSY 2	1			
14	26H-11133-10	.GUIDE, INTAKE VALVE	8			
15	93440-12117	.CIRCLIP	8			
16	91808-18023	.PIN, DOWEL	16			
17	90105-06153	.BOLT, WASHER BASED	16			
18	90340-18101	.PLUG, STRAIGHT SCREW	3			
19	95617-08620	.BOLT, STUD	4			
20	26H-12469-01	JOINT 1	1			
21	93210-18629	O-RING	1			
22	93210-18322	O-RING	1			
23	93210-21631	O-RING	1			
24	90254-03008	PIN, SPRING	1			
25	94701-00262	PLUG, SPARK (NGK DPR7EA 9)	4			UR
	94701-00379	PLUG, SPARK (ND X22EPR-U9)	4			UR
26	1NL-11181-00	GASKET, CYLINDER HEAD 1	2			

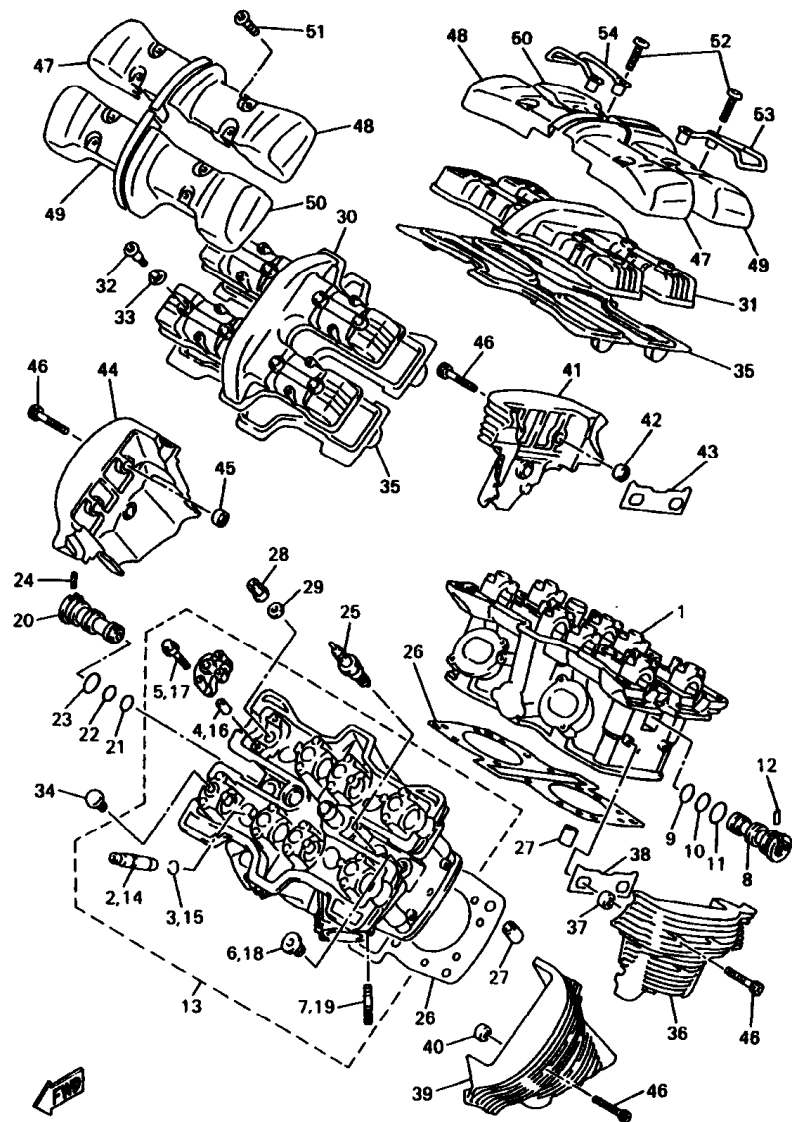

4NK110-6010

FIG. 1 CYLINDER HEAD

REF. NO.	PART NO.	DESCRIPTION	QTY	REMARKS
27	99530-14016	PIN, DOWEL	4	
28	90179-10414	NUT	16	
29	90201-102G9	WASHER, PLATE	16	
30	4NK-11191-00	COVER, CYLINDER HEAD 1	1	
31	4NK-11191-00	COVER, CYLINDER HEAD 1	1	
32	90109-066F0	BOLT	16	
33	4KG-1111G-00	RUBBER, MOUNT 1	16	
34	90338-10150	PLUG	16	
35	4NK-11193-00	GASKET, HEAD COVER 1	2	
36	4NK-11186-00	COVER, CYLINDER HEAD SIDE 2	1	
37	4NK-15316-00	DAMPER, ENGINE MOUNT 1	3	
38	4NK-11195-00	GASKET	1	
39	4NK-11187-00	COVER, CYLINDER HEAD SIDE 3	1	
40	4NK-15316-00	DAMPER, ENGINE MOUNT 1	3	
41	4NK-11185-00	COVER, CYLINDER HEAD SIDE 1	1	
42	4NK-15316-00	DAMPER, ENGINE MOUNT 1	3	
43	4NK-11195-00	GASKET	1	
44	4NK-1111H-00	COVER, CYLINDER HEAD SIDE 4	1	
45	4NK-15316-00	DAMPER, ENGINE MOUNT 1	3	
46	91314-06020	BOLT	12	
47	4NK-1111M-00	COVER 1	2	
48	4NK-1111N-00	COVER 2	2	
49	4NK-1111P-00	COVER 3	2	
50	4NK-1111R-00	COVER 4	2	
51	92014-06014	BOLT, BUTTON HEAD	12	
52	92014-06030	BOLT, BUTTON HEAD	4	
53	4NK-11152-00	BRACKET, CYLINDER HEAD COVER	1	

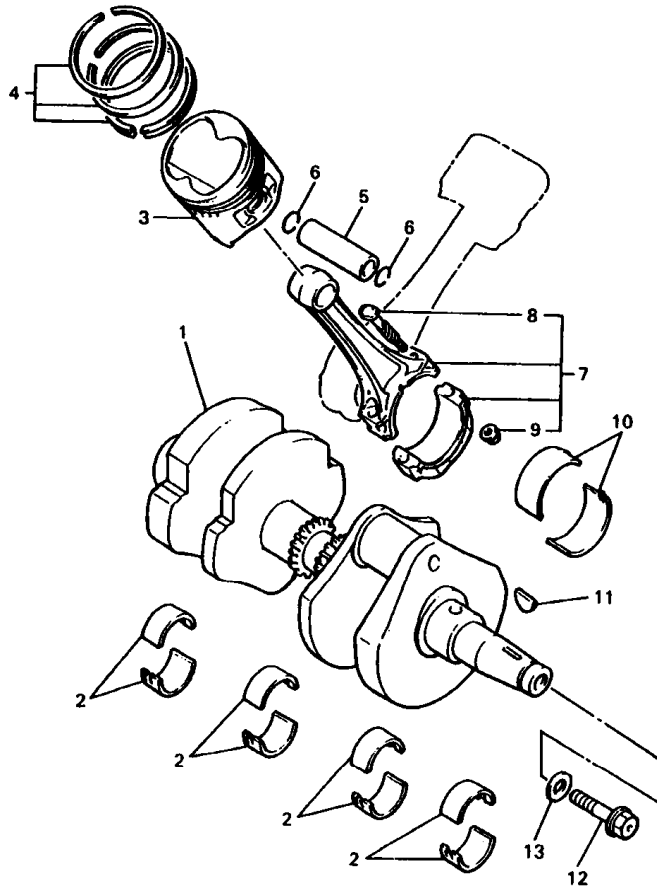

4NK110-6020

FIG. 2 CRANKSHAFT, PISTON

REF. NO.	PART NO.	DESCRIPTION	QTY	YPS	REMARKS
1	4NK-11400-00	CRANKSHAFT ASSY	1		
2	1FK-11416-01	PLANE BEARING, CRANKSHAFT 1	8		UR BLUE
	1FK-11416-11	PLANE BEARING, CRANKSHAFT 1	8		UR BLACK
	1FK-11416-21	PLANE BEARING, CRANKSHAFT 1	8		UR BROWN
	1FK-11416-31	PLANE BEARING, CRANKSHAFT 1	8		UR GREEN
	1FK-11416-41	PLANE BEARING, CRANKSHAFT 1	8		UR YELLOW
	1FK-11416-51	PLANE BEARING, CRANKSHAFT 1	8		UR PINK
	1FK-11416-61	PLANE BEARING, CRANKSHAFT 1	8		UR RED
3	4NK-11631-00-A0	PISTON (STD)	4		
	4NK-11635-00	PISTON (0.25MM O/S)	4		AP
	4NK-11636-00	PISTON (0.50MM O/S)	4		AP
4	1NL-11610-00	PISTON RING SET (STD)	4		
	1NL-11610-10	PISTON RING SET (0.25MM O/S)	4		AP
	1NL-11610-20	PISTON RING SET (0.50MM O/S)	4		AP
5	1FK-11633-00	PIN, PISTON	4		
6	93450-19095	CIRCLIP	8		
7	26H-11650-00	CONNECTING ROD ASSY	4		
8	26H-11654-00	.BOLT, CONNECTING ROD	2		
9	90179-08327	.NUT	2		
10	1FK-11658-00	PLANE BEARING, CONNECTING ROD	8		UR BLUE
	1FK-11658-10	PLANE BEARING, CONNECTING ROD	8		UR BLACK
	1FK-11658-20	PLANE BEARING, CONNECTING ROD	8		UR BROWN
	1FK-11658-30	PLANE BEARING, CONNECTING ROD	8		UR GREEN
	1FK-11658-40	PLANE BEARING, CONNECTING ROD	8		UR YELLOW
	1FK-11658-50	PLANE BEARING, CONNECTING ROD	8		UR PINK
11	90280-05029	KEY, WOODRUFF	1		
12	90105-12584	BOLT, WASHER BASED	1		

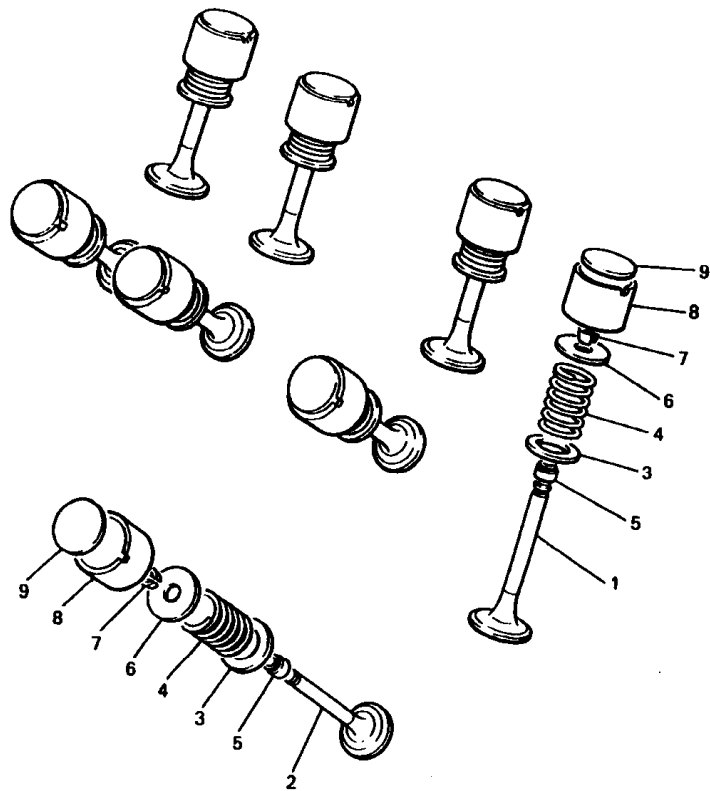

4NK110-6030

FIG. 3 VALVE

REF. NO.	PART NO.	DESCRIPTION	4YP3				REMARKS
1	26H-12111-11	VALVE, INTAKE	8				
2	26H-12121-11	VALVE, EXHAUST	8				
3	26H-12116-00	SEAT, VALVE SPRING	16				
4	4NK-12114-00	SPRING, VALVE OUTER	16				
5	4KM-12119-00	SEAL, VALVE STEM	16				
6	26H-12117-00	RETAINER, VALVE SPRING	16				
7	4G0-12118-00	COTTER, VALVE	32				
8	26H-12153-00-Y0	LIFTER, VALVE	16				UR
	26H-12153-00-J0	LIFTER, VALVE(O/S)	16				UR
9	26H-12168-00	PAD, ADJUSTING (2.00)	16				UR
	26H-12168-20	PAD, ADJUSTING (2.05)	16				UR
	26H-12168-40	PAD, ADJUSTING (2.10)	16				UR
	26H-12168-60	PAD, ADJUSTING (2.15)	16				UR
	26H-12168-80	PAD, ADJUSTING (2.20)	16				UR
	26H-12168-A0	PAD, ADJUSTING (2.25)	16				UR
	26H-12168-F0	PAD, ADJUSTING (2.30)	16				UR
	26H-12168-H0	PAD, ADJUSTING (2.35)	16				UR
	26H-12168-K0	PAD, ADJUSTING (2.40)	16				UR
	26H-12168-M0	PAD, ADJUSTING (2.45)	16				UR
	26H-12168-R0	PAD, ADJUSTING (2.50)	16				UR
	26H-12168-LU0	PAD, ADJUSTING (2.55)	16				UR
	26H-12168-W0	PAD, ADJUSTING (2.60)	16				UR
	26H-12168-Y0	PAD, ADJUSTING (2.65)	16				UR
	26H-12169-10	PAD, ADJUSTING (2.70)	16				UR
	26H-12169-30	PAD, ADJUSTING (2.75)	16				UR
	26H-12169-50	PAD, ADJUSTING (2.80)	16				UR
	26H-12169-70	PAD, ADJUSTING (2.85)	16				UR

FIG. 3 VALVE

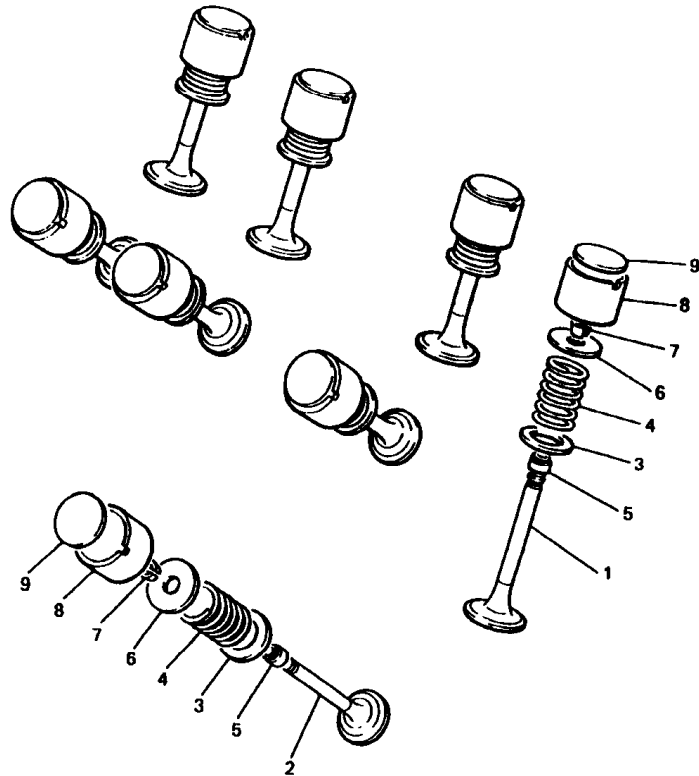

REF. NO.	PART NO.	DESCRIPTION	4YPS				REMARKS
9	26H-12169-90	PAD, ADJUSTING (2.90)	16				UR
	26H-12169-E0	PAD, ADJUSTING (2.95)	16				UR
	26H-12169-G0	PAD, ADJUSTING (3.00)	16				UR
	26H-12169-J0	PAD, ADJUSTING (3.05)	16				UR
	26H-12169-L0	PAD, ADJUSTING (3.10)	16				UR
	26H-12169-N0	PAD, ADJUSTING (3.15)	16				UR
	26H-12169-T0	PAD, ADJUSTING (3.20)	16				UR

4NK110-6030

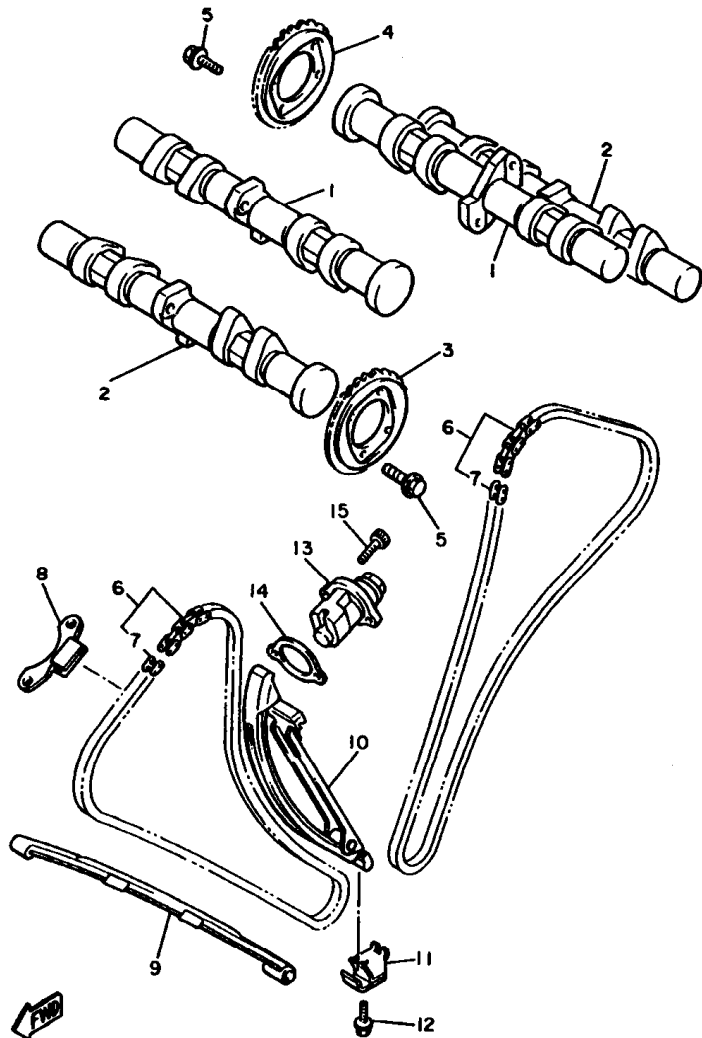

26H110-3030

FIG. 4 CAMSHAFT. CHAIN

REF. NO.	PART NO.	DESCRIPTION	QTY	REMARKS
1	2WT-12171-00	CAMSHAFT 1	2	
2	1NL-12181-00	CAMSHAFT 2	2	
3	26H-12177-01	SPROCKET, CAM CHAIN	2	
4	26H-12176-02	SPROCKET, CAM CHAIN	2	
5	90105-07342	BOLT, WASHER BASED	8	
6	94590-44118	CHAIN (BF05M-118L)	2	
7	94600-02001	.JOINT, CHAIN (BF05M)	2	TSUBAKIMOTO
8	26H-12241-00	GUIDE, STOPPER 2	2	
9	26H-12251-00	DAMPER, CHAIN 1	2	
10	26H-12252-00	DAMPER, CHAIN 2	2	
11	26H-12233-00	PLATE, GUIDE STOPPER 1	1	
12	95817-08025	BOLT, FLANGE	1	
13	26H-12210-03	TENSIONER ASSY, CAM CHAIN	2	
14	3JP-12213-01	GASKET, TENSIONER CASE	2	
15	91317-06020	BOLT	4	

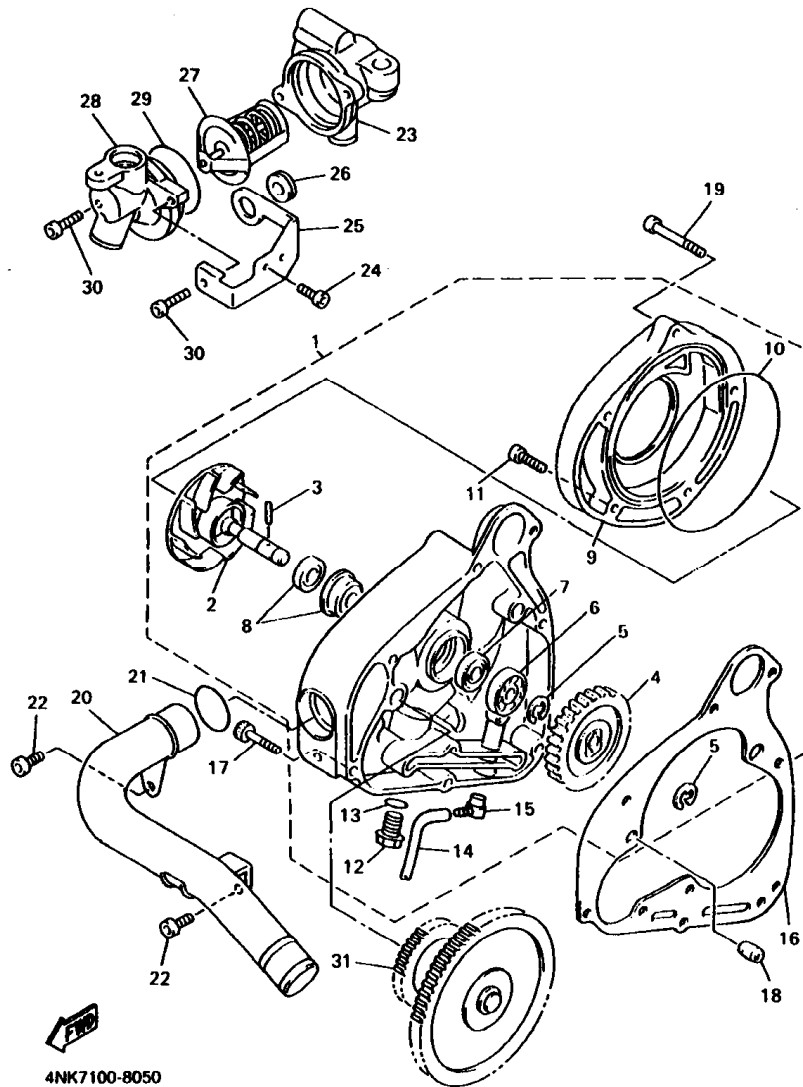
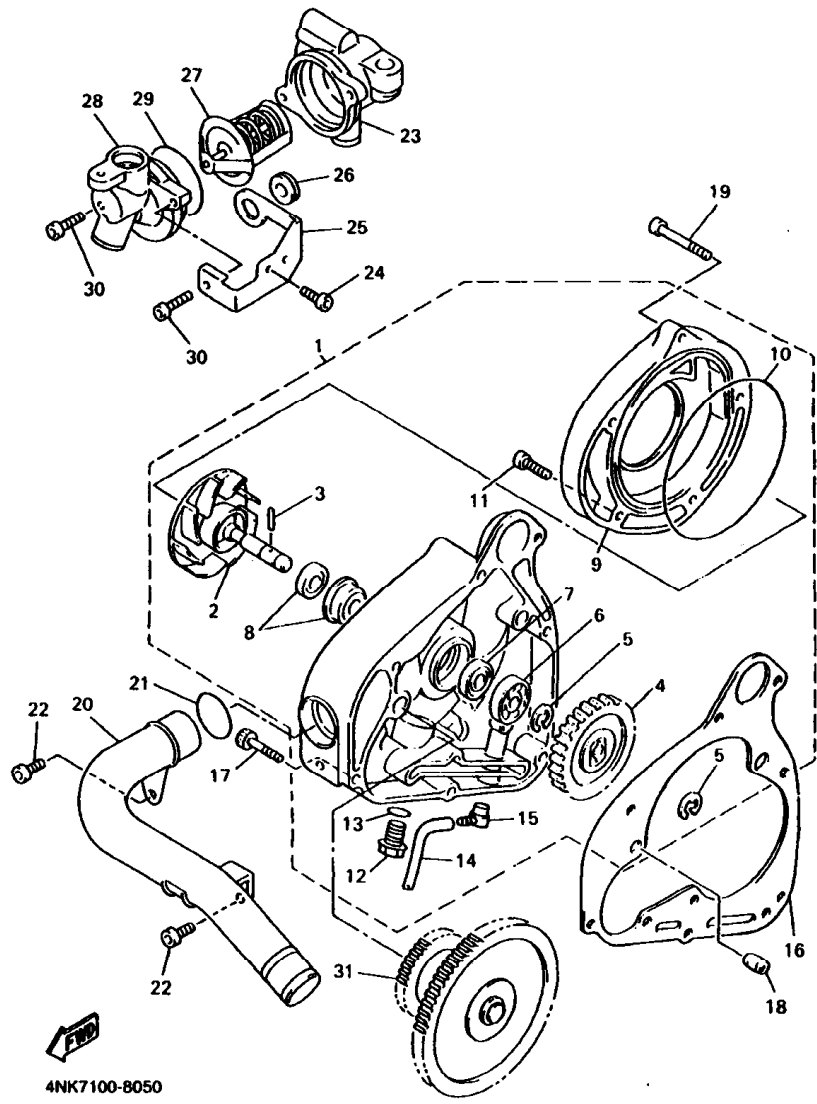

FIG. 5 WATER PUMP

REF. NO.	PART NO.	DESCRIPTION	AYP3				REMARKS
1	4NK-12420-02	WATER PUMP ASSY	1				
2	1FK-12450-00	.IMPELLER SHAFT ASSY	1				
3	93803-14026	.PIN, DOWEL	1				
4	26H-12459-00	.GEAR, IMPELLER SHAFT (31T)	1				
5	99009-10400	.CIRCLIP	2				
6	93306-00006	.BEARING (B6000)	1				
7	93101-10090	.OIL SEAL	1				
8	11H-12438-00	.SEAL, MECHANICAL	1				
9	4NK-W1241-01	.COVER, HOUSING	1				
10	93211-113A8	.O-RING	1				
11	91314-06030	.BOLT	2				
12	90340-14132	.PLUG, STRAIGHT SCREW	1				
13	214-11198-01	.GASKET	1				
14	90445-05278	.HOSE	1				
15	353-13552-01	.NOZZLE	1				
16	4NK-12449-00	GASKET, WATER PUMP	1				
17	91314-06025	BOLT	4				
18	99530-10114	PIN, DOWEL	2				
19	91314-06080	BOLT	3				
20	4NK-12483-00	PIPE 3	1				
21	93210-23787	O-RING	1				
22	91314-06014	BOLT	2				
23	4NK-12417-00	HOUSING, THERMOSTAT	1				
24	91317-06016	BOLT	1				
25	4NK-1244E-00	BRACKET 1	1				
26	90480-18276	GROMMÉT	1				
27	1AE-12410-00	THERMOSTAT ASSY	1				



4NK7100-8050

FIG. 5 WATER PUMP

REF. NO.	PART NO.	DESCRIPTION	QTY	REMARKS
28	4NK-12413-00	COVER, THERMOSTAT	1	
29	93210-49046	O-RING	1	
30	91317-06020	BOLT	2	
31	4NK-12450-00	IMPELLER SHAFT ASSY	1	

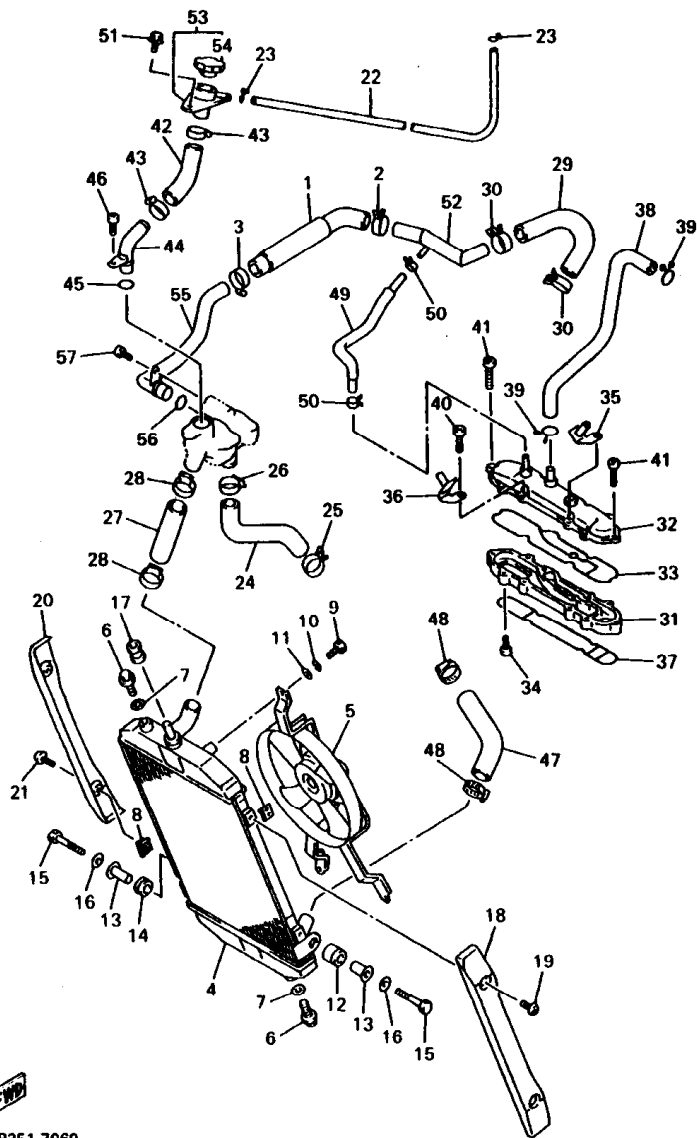

4YP351-7060

FIG. 6 RADIATOR. HOSE

REF. NO.	PART NO.	DESCRIPTION	4YP3				REMARKS
1	4NK-12578-00	HOSE 3	1				
2	90467-23109	CLIP	1				
3	90450-28014	HOSE CLAMP ASSY	1				
4	4NK-12461-02	RADIATOR ASSY	1				
5	4NK-12405-01	BLOWER ASSY	1				
6	1AA-12561-00	PLUG, DRAIN COCK	2				
7	1AA-12435-00	GASKET	2				
8	4NK-12671-00	NUT 1	4				
9	97007-06012	BOLT	3				
10	92907-06100	WASHER, SPRING	3				
11	92907-06600	WASHER, PLATE	3				
12	4NK-12465-00	DAMPER, RADIATOR	1				
13	90387-0609L	COLLAR	2				
14	90480-19283	GROMMET	1				
15	97007-06040	BOLT	2				
16	92907-06600	WASHER, PLATE	2				
17	90480-16284	GROMMET	1				
18	4WY-1240J-00	RADIATOR COVER ASSY 1	1				
19	92017-06010	BOLT, BUTTON HEAD	2				
20	4WY-1240K-00	RADIATOR COVER ASSY 2	1				
21	92017-06010	BOLT, BUTTON HEAD	2				
22	90445-097F7	HOSE	1				
23	90467-08003	CLIP	2				
24	4NK-12576-00	HOSE 1	1				
25	90467-23109	CLIP	1				
26	90450-32051	HOSE CLAMP ASSY	1				
27	4NK-12579-00	HOSE 4	1				

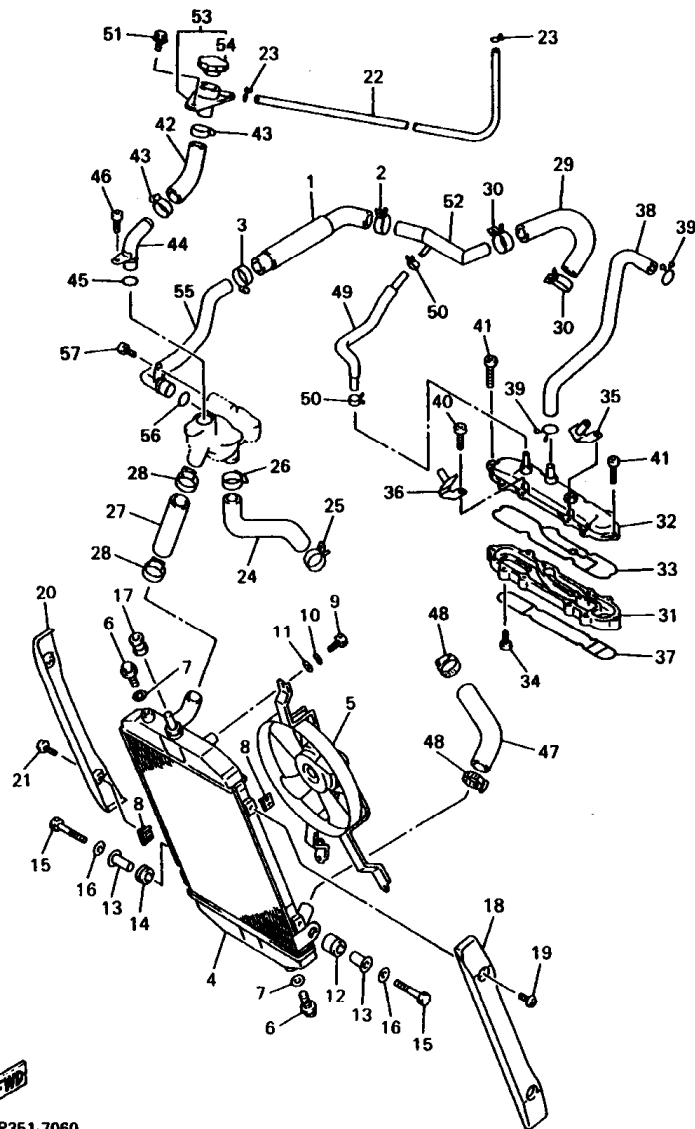

4YP351-7060

FIG. 6 RADIATOR HOSE

REF. NO.	PART NO.	DESCRIPTION	4YP3				REMARKS
28	90450-38040	HOSE CLAMP ASSY	2				
29	4NK-12577-00	HOSE 2	1				
30	90467-23109	CLIP	1				
31	26H-1246A-03	COVER 1	1				
32	26H-1246E-03	COVER 2	1				
33	26H-12428-00	GASKET, HOUSING COVER 2	1				
34	91314-06016	BOLT	4				
35	4NK-14413-00	STAY	1				
36	4NK-14414-00	STAY 2	1				
37	26H-12427-00	GASKET, HOUSING COVER 1	1				
38	4NK-11166-00	PIPE, BREATHER 1	1				
39	90467-14015	CLIP	2				
40	4NK-12615-00	BOLT	4				
41	91314-06040	BOLT	2				
42	4NK-12589-00	HOSE 6	1				
43	90450-28014	HOSE CLAMP ASSY	2				
44	4NK-12484-00	PIPE 4	1				
45	93210-18417	O-RING	1				
46	91317-06010	BOLT	1				
47	4NK-12588-00	HOSE 5	1				
48	90450-38040	HOSE CLAMP ASSY	2				
49	4NK-12551-00	HOSE 7	1				
50	90467-11090	CLIP	2				
51	95827-06012	BOLT, FLANGE	2				
52	4NK-12481-00	PIPE 1	1				
53	4NK-12560-00	CONDUCTION ASSY	1				
54	3XP-12482-00	.CAP, RADIATOR	1				

FIG. 7 OIL PUMP

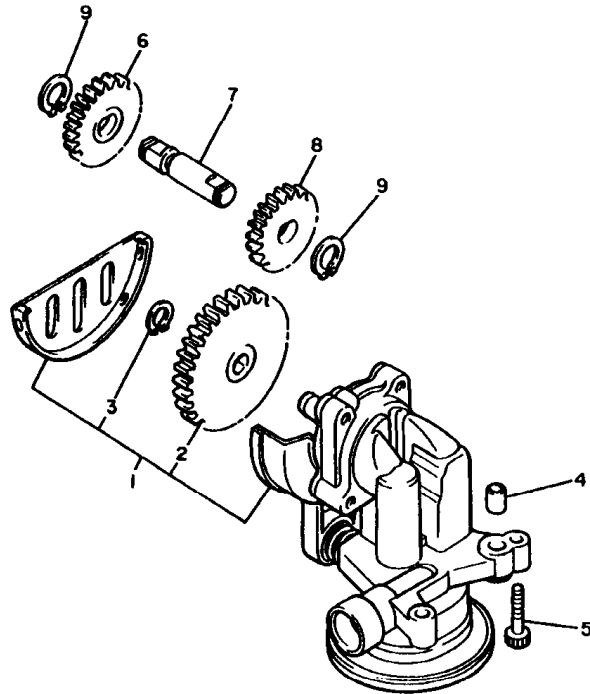

REF. NO.	PART NO.	DESCRIPTION	QTY	REMARKS
1	26H-13300-02	OIL PUMP ASSY	1	
2	26H-13325-00	.GEAR, PUMP DRIVEN (28T)	1	
3	99009-11400	.CIRCLIP	1	
4	99530-10114	PIN, DOWEL	2	
5	91317-06025	BOLT	3	
6	26H-13351-01	GEAR, PUMP IDLE 1 (16T)	1	
7	26H-13342-00	SHAFT, IDLE GEAR	1	
8	26H-13361-00	GEAR, PUMP IDLE 2 (15T)	1	
9	99009-12400	CIRCLIP	2	

26H110-3070

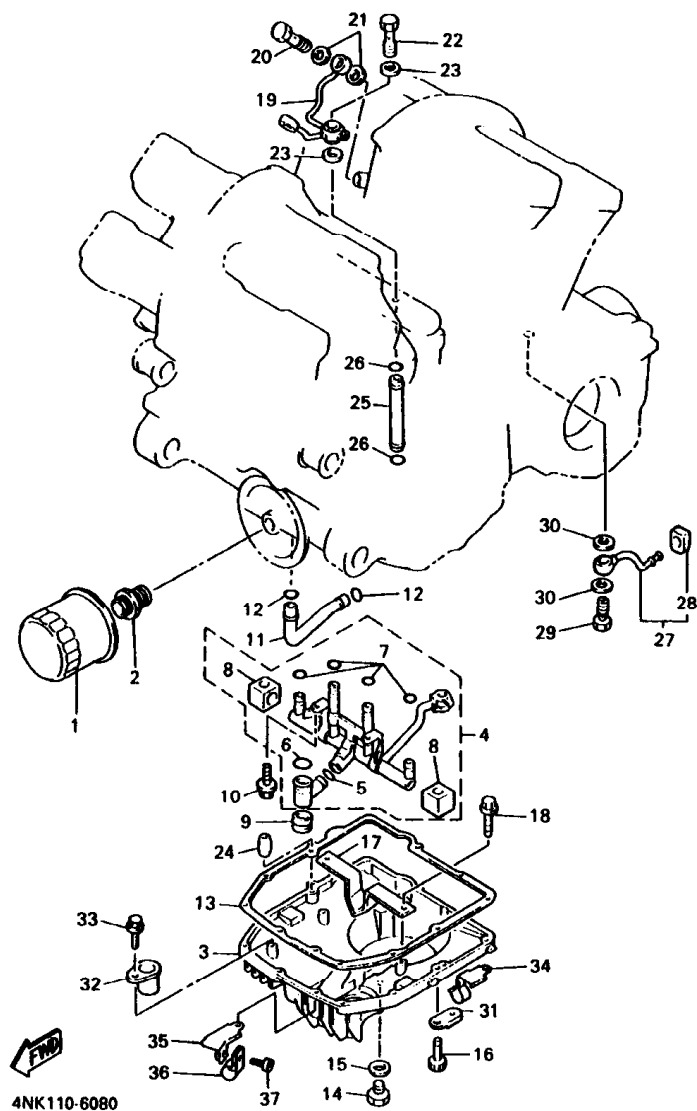

FIG. 8 OIL CLEANER

REF. NO.	PART NO.	DESCRIPTION	QTY	REMARKS
1	3FV-13440-00	ELEMENT ASSY, OIL CLEANER	1	
2	90401-20145	BOLT, UNION	1	
3	26H-13417-01	COVER, STRAINER	1	
4	26H-Y1319-10	DELIVERY PIPE ASS'Y	1	
5	93210-13361	.O-RING	1	
6	93210-14637	.O-RING	1	
7	93210-06667	.O-RING	4	
8	26H-15365-00	.GROMMET	2	
9	26H-15366-01	GROMMET	1	
10	95817-06012	BOLT, FLANGE	2	
11	26H-13161-00	PIPE, DELIVERY 1	1	
12	93210-14579	O-RING	2	
13	3JP-13414-01	GASKET, STRAINER COVER	1	
14	90340-14132	PLUG, STRAIGHT SCREW	1	
15	214-11198-01	GASKET	1	
16	91317-06030	BOLT	12	
17	26H-13337-01	PLATE, BAFFLE LOWER	1	
18	95817-06012	BOLT, FLANGE	2	
19	26H-13181-03	PIPE, DELIVERY 3	1	
20	90401-08038	BOLT, UNION	2	
21	90430-08119	GASKET	4	
22	90401-10108	BOLT, UNION	1	
23	90201-10128	WASHER, PLATE	2	
24	99530-08016	PIN, DOWEL	2	
25	26H-13171-00	PIPE, DELIVERY 2	1	
26	93210-06667	O-RING	2	
27	26H-13416-01	PIPE, OIL 1	1	

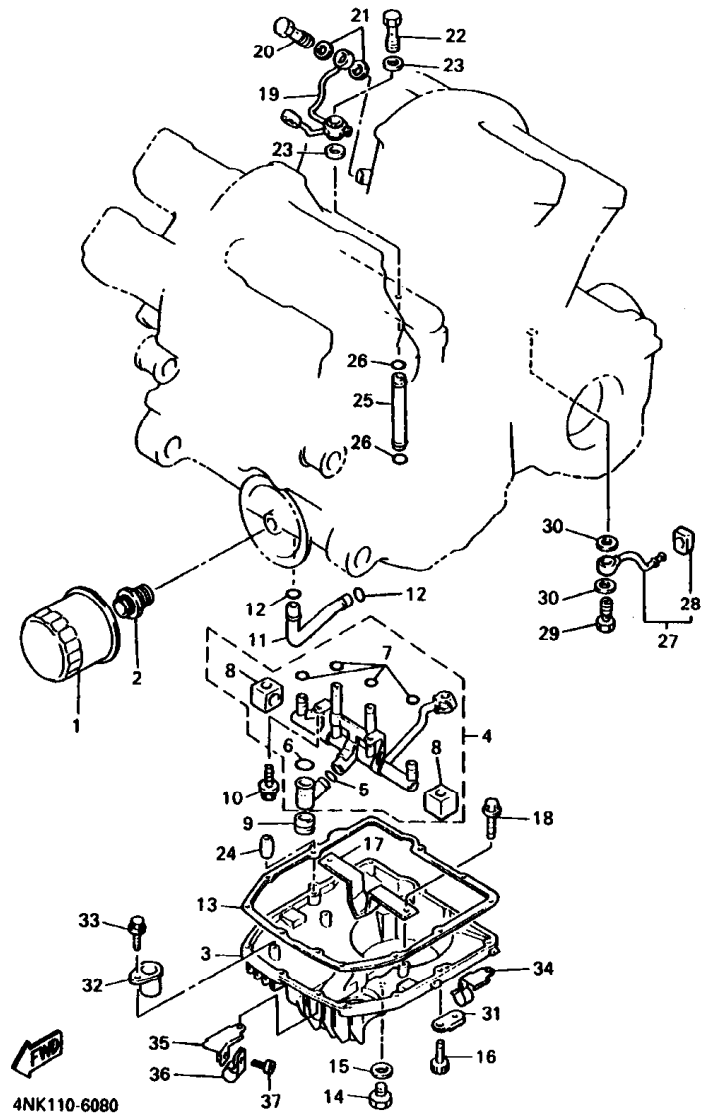
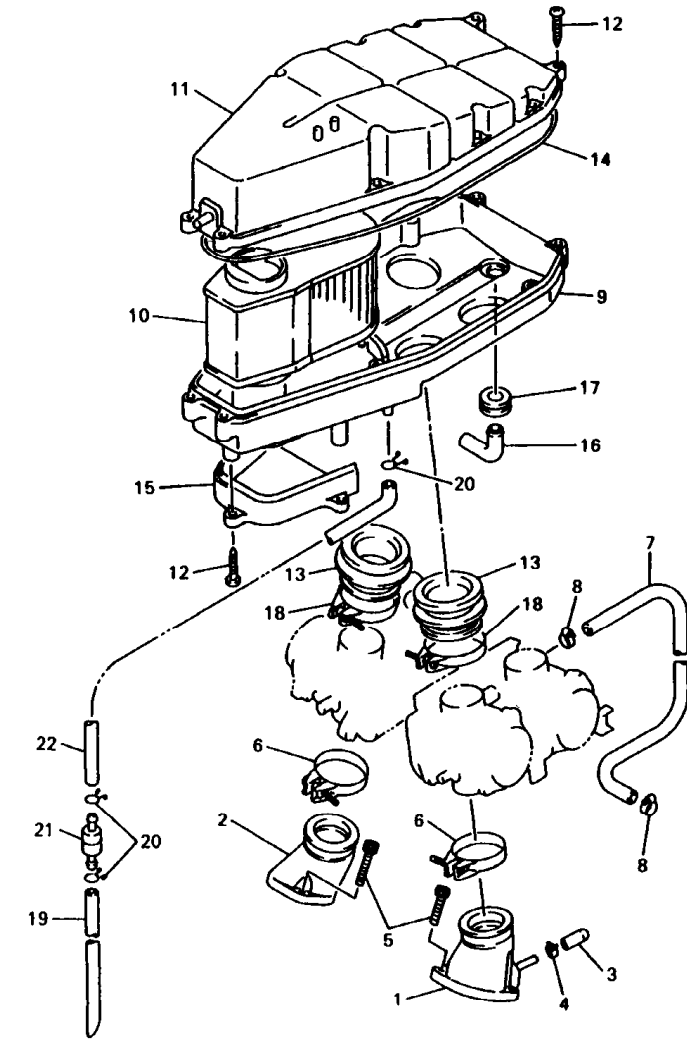

FIG. 8 OIL CLEANER

REF. NO.	PART NO.	DESCRIPTION	QTY	REMARKS
28	26H-13476-00	GASKET	1	
29	90401-08093	BOLT, UNION	1	
30	90430-08119	GASKET	2	
31	90465-08193	CLAMP	1	
32	1FK-13151-00	STAY	1	
33	95817-06012	BOLT, FLANGE	1	
34	90462-10226	CLAMP	1	
35	4NK-13782-00	STAY	1	
36	90461-15100	CLAMP	1	
37	91317-05010	BOLT	1	

FIG. 9 INTAKE



4NK110-6090

REF. NO.	PART NO.	DESCRIPTION	QTY	REMARKS
1	4NK-13588-00	JOINT, CARBURETOR 1	2	
2	4NK-13596-00	JOINT, CARBURETOR 2	2	
3	16G-13569-00	PLUG, BLIND	4	
4	90467-10039	CLIP	4	
5	91317-06020	BOLT	8	
6	4DN-13575-00	BAND	4	
7	90445-124J5	HOSE	1	
8	90467-13123	CLIP	2	
9	4NK-14411-00	CASE, AIR CLEANER 1	1	
10	4NK-14451-00	ELEMENT, AIR CLEANER	1	
11	4NK-14421-00	CASE, AIR CLEANER 2	1	
12	97707-50130	SCREW, TAPPING	13	
13	4NK-14453-00	JOINT, AIR CLEANER 1	4	
14	4NK-14452-00	SEAL	1	
15	4NK-14437-00	DUCT	1	
16	31A-14419-00	PIPE	1	
17	31A-14435-00	GROMMET	1	
18	90460-54085	CLAMP, HOSE	4	
19	90445-115J9	HOSE	1	
20	90467-11106	CLIP	3	
21	4X7-2149Y-00	FILTER ASSY	1	
22	4NK-14419-00	PIPE	1	

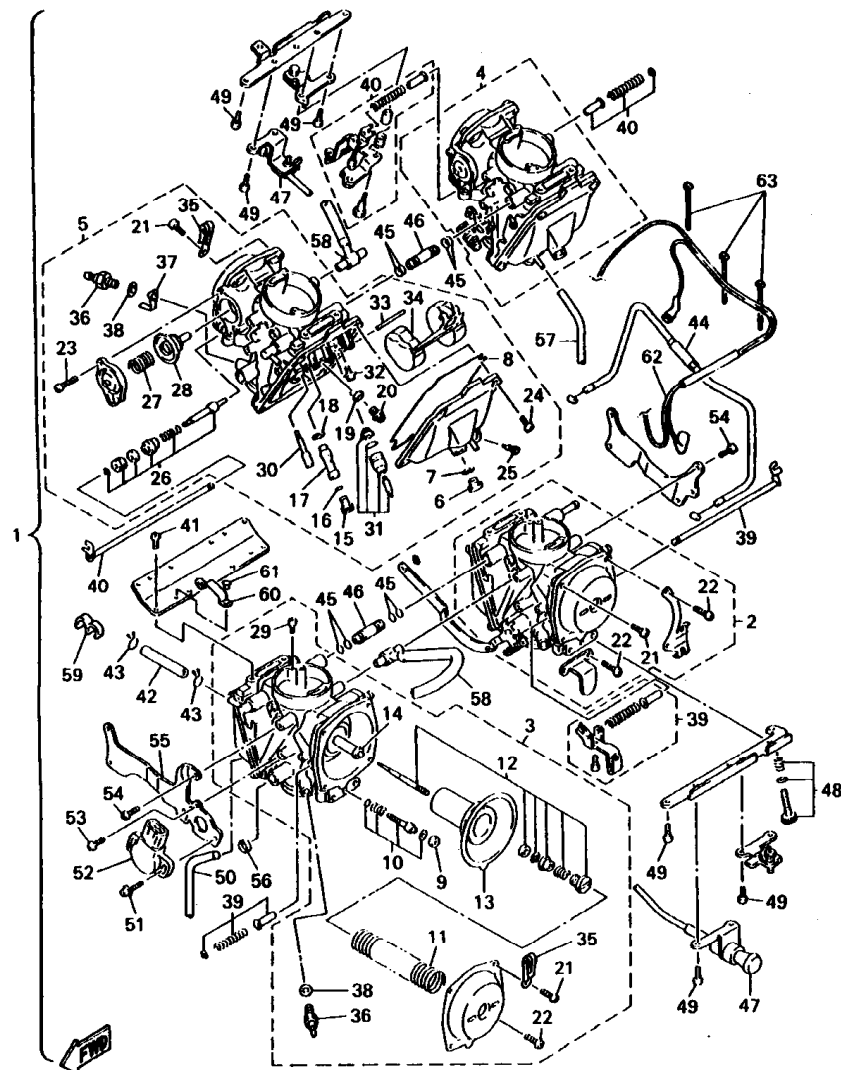

4YE5100-8110

FIG. 10 CARBURETOR

REF. NO.	PART NO.	DESCRIPTION	4YP3		REMARKS
1	4YP-14900-00	CARBURETOR ASSY	1		
2	4YP-14901-00	.CARBURETOR ASSY 1	1		
3	4YP-14902-00	.CARBURETOR ASSY 2	1		
4	4YP-14903-00	.CARBURETOR ASSY 3	1		
5	4YP-14904-00	.CARBURETOR ASSY 4	1		
6	22U-14115-00	..PLUG, SCREW	1		
7	22U-14561-00	..O-RING	1		
8	1HX-14147-00	..O-RING	1		
9	22F-14991-00	..CAP	1		
10	3KW-14105-00	..PILOT SCREW SET	1		
11	3KW-14933-00	..SPRING, DIAPHRAGM	1		
12	4WY-1490J-00	..NEEDLE SET	1		
13	4WY-14940-00	..DIAPHRAGM ASSY	1		
14	3DM-14141-30	..MAIN NOZZLE(0-0)	1		
15	3G2-14231-19	..JET, POWER (# 95)	1		
16	1AE-14227-00	..O-RING	1		
17	1AE-14261-00	..HOLDER	1		
18	1AE-14237-00	..GASKET	1		
19	137-14153-00	..WASHER, MAIN JET	1		
20	1HX-14565-00	..SCREW	1		
21	98580-04008	..SCREW, PAN HEAD	1		UR #1
	98580-04008	..SCREW, PAN HEAD	3		UR #2
	98580-04008	..SCREW, PAN HEAD	4		UR #3,4
22	97890-04010	..SCREW, PAN HEAD	3		UR #1
	97890-04010	..SCREW, PAN HEAD	1		UR #2
23	1UY-14565-00	..SCREW	2		
24	98507-04014	..SCREW, PAN HEAD	4		

FIG. 10 CARBURETOR

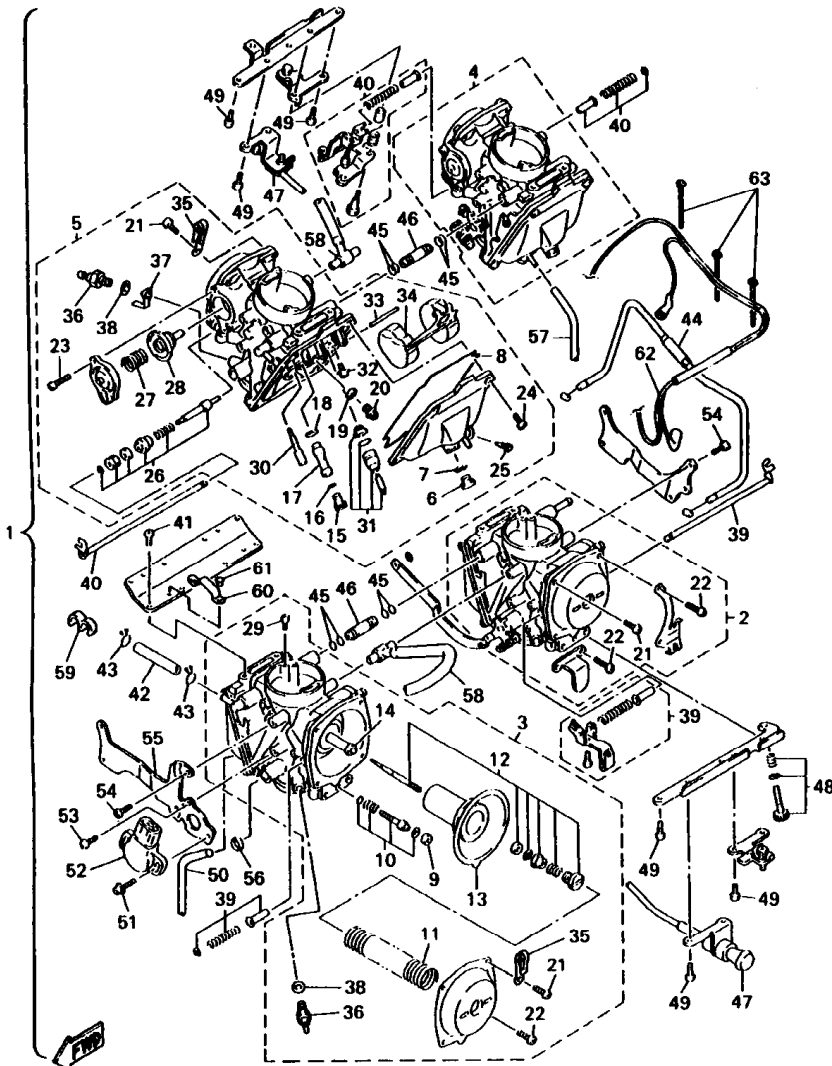

4YE5100-8110

REF. NO.	PART NO.	DESCRIPTION	QTY	REMARKS
25	12R-14191-00	..PLUG, DRAIN	1	
26	4DN-1410A-01	..STARTER SET	1	
27	4NK-14935-00	..SPRING	1	
28	22V-14940-00	..DIAPHRAGM ASSY	1	
29	1HX-14231-23	..JET, MAIN (#115)	1	
30	22F-14142-20	..JET, PILOT (# 20)	1	
31	3CF-14107-15	..NEEDLE VALVE SET	1	
32	1FN-14585-00	..SCREW	1	
33	353-14186-00	..PIN, FLOAT	1	
34	1HX-14985-00	..FLOAT	1	
35	90461-08087	..CLAMP	1	
36	4EB-83790-00	..HEATER ASSY	1	
37	4DH-82103-00	..TERMINAL 1	1	
38	90201-085R5	..WASHER, PLATE	1	
39	4NK-1490L-00	..STARTER LEVER SET, 1	1	
40	4NK-1490L-10	..STARTER LEVER SET, 1	1	
41	98507-05010	..SCREW, PAN HEAD	8	
42	4NK-14396-00	..PIPE	1	
43	4NK-14137-00	..CLIP	2	
44	4NK-14130-00	..CABLE	1	
45	36Y-14147-00	..O-RING	8	
46	1WG-14251-00	..NIPPLE	2	
47	4NK-14130-12	..CABLE	1	
48	4NK-14103-00	..THROTTLE SCREW SET	1	
49	98507-05012	..SCREW, PAN HEAD	9	
50	3JD-14197-00	..PIPE	2	
51	4KM-24453-00	..SCREW	2	

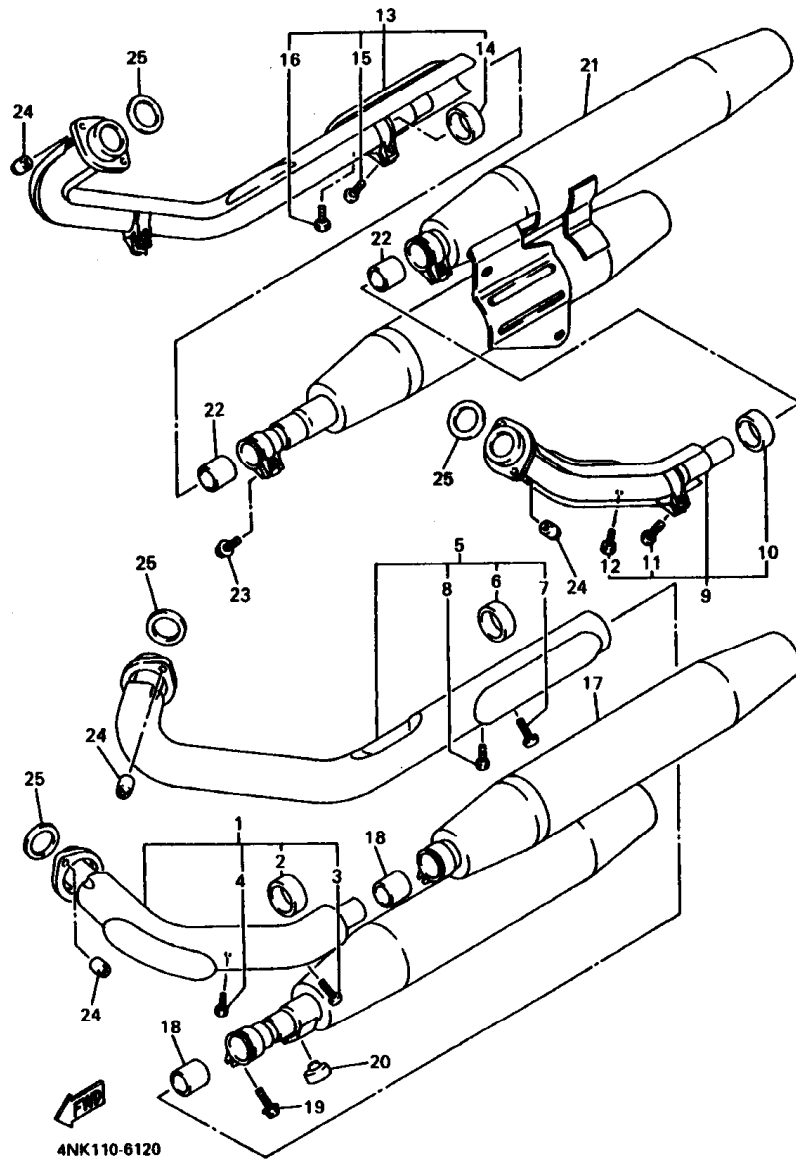

FIG. 11 EXHAUST

REF. NO.	PART NO.	DESCRIPTION	4YP3				REMARKS
1	4NK-14610-00	EXHAUST PIPE ASSY 1	1				
2	4NK-14714-00	.GASKET, MUFFLER	1				
3	92017-08020	.BOLT, BUTTON HEAD	1				
4	97080-06008	.BOLT	1				
5	4NK-14620-00	EXHAUST PIPE ASSY 2	1				
6	4NK-14714-00	.GASKET, MUFFLER	2				
7	92017-08025	.BOLT, BUTTON HEAD	2				
8	97080-06008	.BOLT	1				
9	4NK-14630-00	EXHAUST PIPE ASSY 3	1				
10	4NK-14714-00	.GASKET, MUFFLER	1				
11	92017-08020	.BOLT, BUTTON HEAD	1				
12	97080-06008	.BOLT	1				
13	4NK-14650-00	EXHAUST PIPE ASSY 4	1				
14	4NK-14714-00	.GASKET, MUFFLER	2				
15	92017-08025	.BOLT, BUTTON HEAD	2				
16	97080-06008	.BOLT	1				
17	4YP-14703-00	MUFFLER COMP. 1	1				
18	4BH-14714-00	GASKET, MUFFLER	2				
19	95027-08020	BOLT, FLANGE	2				
20	116-27114-00	STOPPER, MAIN STAND	1				
21	4YP-14704-00	MUFFLER COMP. 2	1				
22	4BH-14714-00	GASKET, MUFFLER	2				
23	95027-08020	BOLT, FLANGE	2				
24	90179-08442	NUT	8				
25	3GD-14613-00	GASKET, EXHAUST PIPE	4				

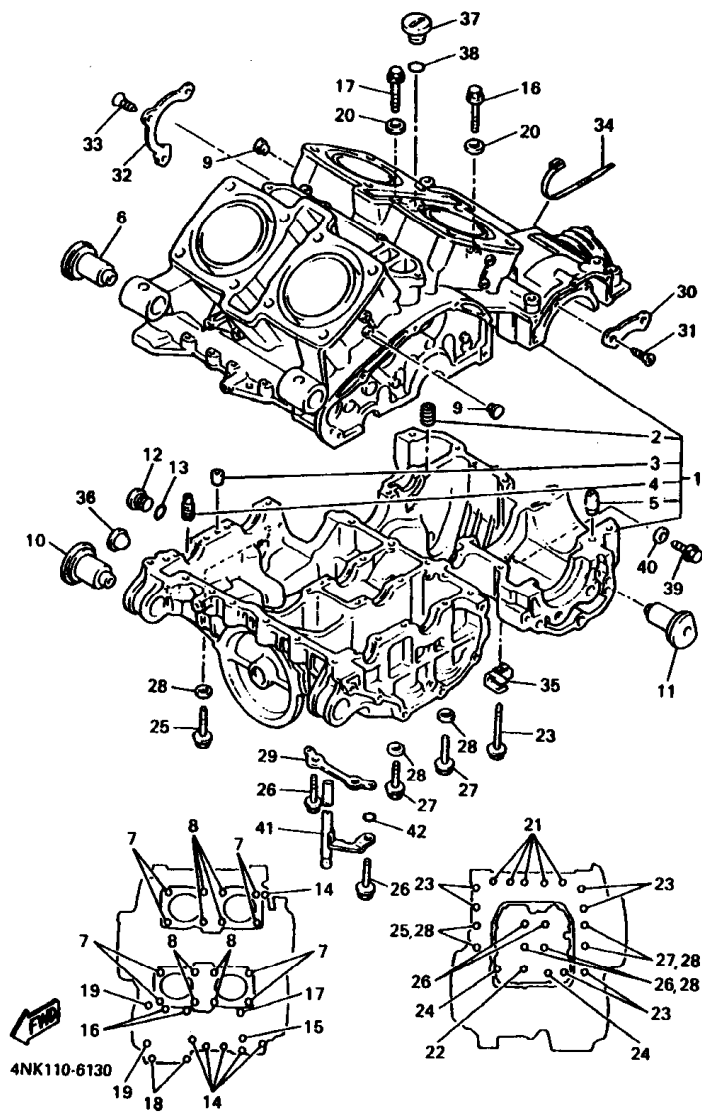

FIG. 12 CRANKCASE

REF. NO.	PART NO.	DESCRIPTION	4VP3			REMARKS
1	4NK-15100-00	CRANKCASE ASSY	1			
2	26H-15138-00	.NOZZLE 1	1			
3	26H-15148-00	.NOZZLE 2	1			
4	4NK-15138-00	.NOZZLE 1	1			
5	99530-10114	.PIN, DOWEL	1			
6	1AA-15338-00	DAMPER, ENGINE MOUNT 3	2			
7	90116-10411	BOLT, STUD	8			
8	90116-10429	BOLT, STUD	8			
9	90338-11152	PLUG	4			
10	1AA-15338-00	DAMPER, ENGINE MOUNT 3	2			
11	1AA-15326-00	DAMPER, ENGINE MOUNT 2	2			
12	4H7-15189-00	PLUG	1			
13	93210-22382	O-RING	1			
14	95814-06045	BOLT, FLANGE	6			
15	95814-06070	BOLT, FLANGE	1			
16	95814-06090	BOLT, FLANGE	2			
17	95817-06095	BOLT, FLANGE	1			
18	95814-08045	BOLT, FLANGE	2			
19	95814-08080	BOLT, FLANGE	2			
20	90430-06166	GASKET	2			
21	95817-08050	BOLT, FLANGE	5			
22	95817-08065	BOLT, FLANGE	1			
23	95814-08080	BOLT, FLANGE	6			
24	95817-08095	BOLT, FLANGE	2			
25	90109-103G0	BOLT	2			
26	90105-10248	BOLT, WASHER BASED	4			
27	90105-10249	BOLT, WASHER BASED	2			

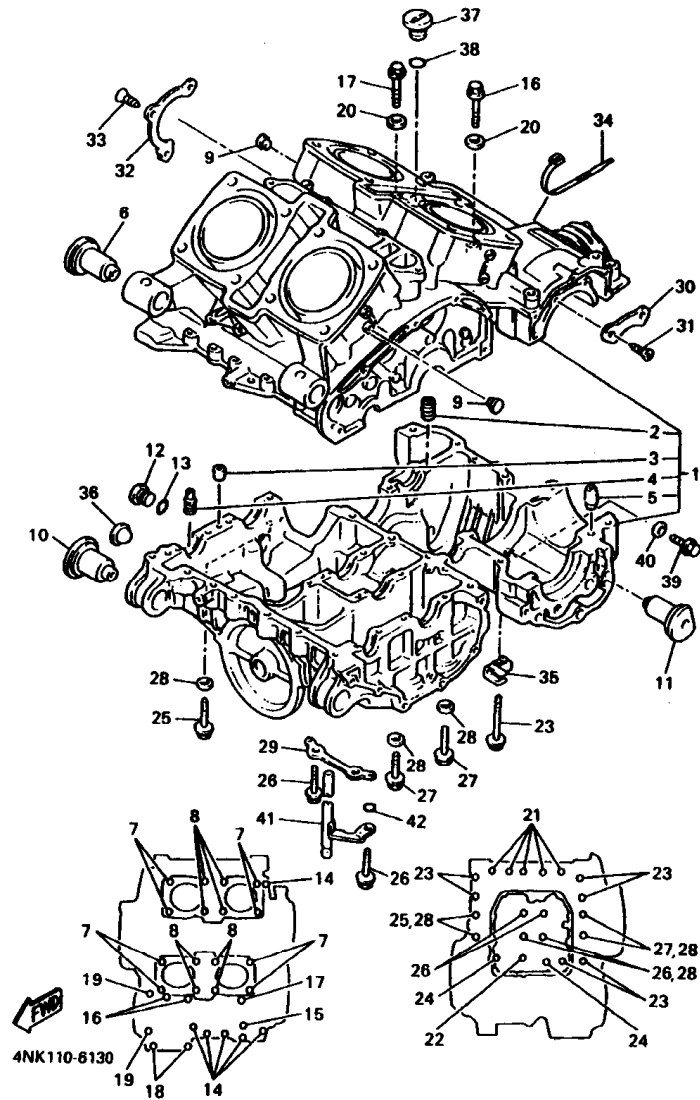
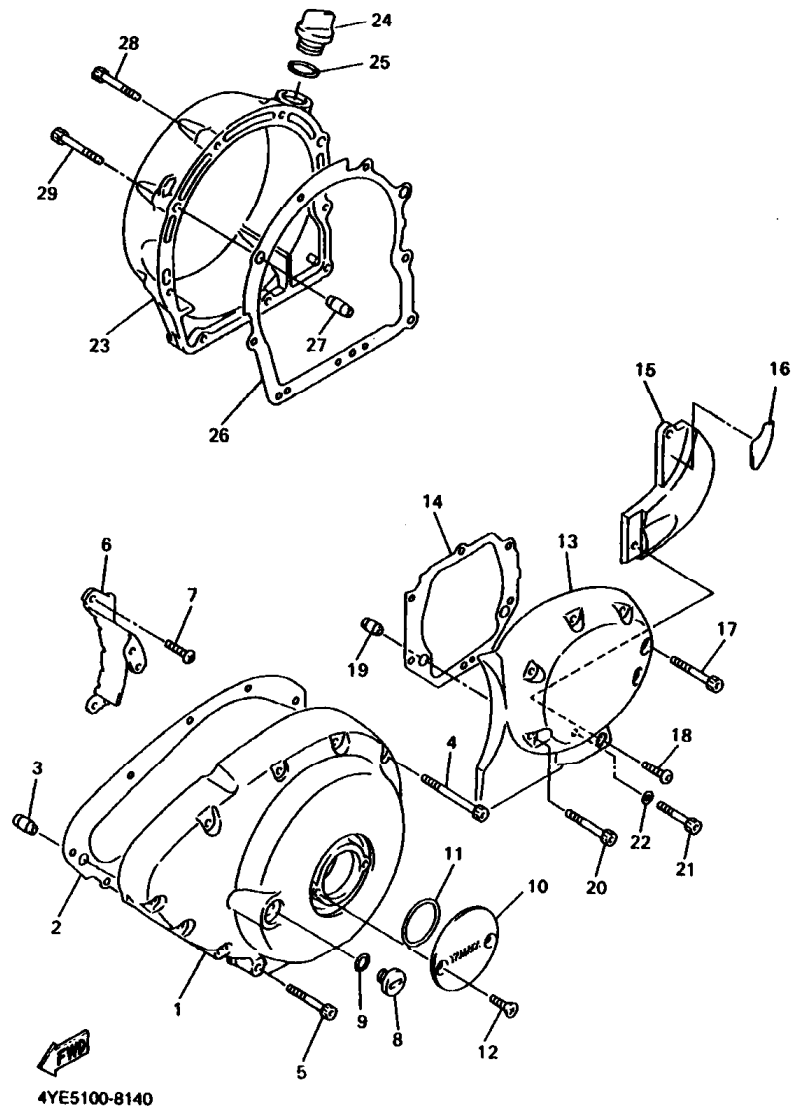

FIG. 12 CRANKCASE

REF. NO.	PART NO.	DESCRIPTION	4YPS				REMARKS
28	90201-11597	WASHER, PLATE	6				
29	26H-15113-00	PLATE	1				
30	26H-15381-00	PLATE, BEARING COVER	2				
31	90149-08152	SCREW	4				
32	26H-15383-00	PLATE, BEARING COVER	1				
33	90151-06041	SCREW, COUNTERSUNK	3				
34	90464-13073	CLAMP	1				
35	90465-08233	CLAMP	1				
36	2H7-15361-00	GAUGE, LEVEL	1				
37	4NK-15383-00	PLUG, OIL	1				
38	93210-27370	O-RING	1				
39	95807-12016	BOLT, FLANGE	1				
40	90201-12790	WASHER, PLATE	1				
41	26H-15373-00	PIPE, BREATHER	1				
42	93210-06667	O-RING	1				



4YE5100-8140

FIG. 13 CRANKCASE COVER 1

REF. NO.	PART NO.	DESCRIPTION	4Y/P3				REMARKS
1	4NK-15411-00	COVER, CRANKCASE 1	1				
2	4NK-15451-00	GASKET, CRANKCASE COVER 1	1				
3	99530-10114	PIN, DOWEL	2				
4	91314-06060	BOLT	4				
5	91314-06045	BOLT	7				
6	4NK-15191-00	PLATE	1				
7	98507-06016	SCREW, PAN HEAD	1				
8	90340-14139	PLUG, STRAIGHT SCREW	1				
9	93210-14369	O-RING	1				
10	4NK-15427-00	COVER, CAP 2	1				
11	93210-45150	O-RING	1				
12	98704-06016	SCREW, FLAT HEAD	2				
13	4NK-15421-00	COVER, CRANKCASE 2	1				
14	3JP-15461-01	GASKET, CRANKCASE COVER 2	1				
15	4NK-15423-00	COVER 2	1				
16	4WY-15316-00	DAMPER, ENGINE MOUNT 1	1				
17	91314-06025	BOLT	1				
18	92014-06014	BOLT, BUTTON HEAD	1				
19	99530-10114	PIN, DOWEL	2				
20	91314-06045	BOLT	3				
21	91314-06035	BOLT	3				
22	90430-06014	GASKET	1				
23	4NK-15431-00	COVER, CRANKCASE 3	1				
24	2H7-15363-00	PLUG, OIL	1				
25	93210-27370	O-RING	1				
26	4NK-15462-00	GASKET, CRANKCASE COVER 3	1				
27	99530-10114	PIN, DOWEL	2				

FIG. 14 STARTER CLUTCH

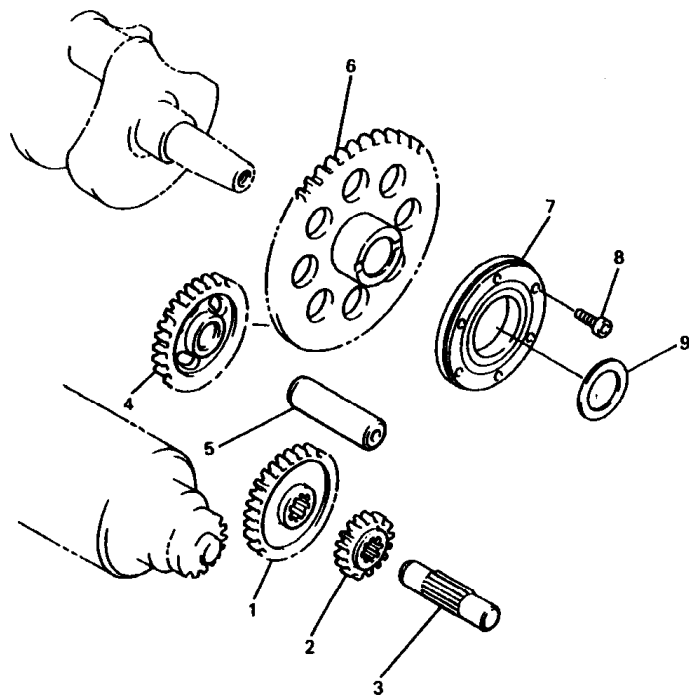

4NK110-6150

REF. NO.	PART NO.	DESCRIPTION	4YF3				REMARKS
1	26H-15514-00	GEAR 2 (42T)	1				
2	26H-15515-00	GEAR 3 (13T)	1				
3	26H-15522-00	SHAFT 2	1				
4	26H-15512-00	GEAR, IDLER 1 (27T)	1				
5	26H-15521-00	SHAFT 1	1				
6	4NK-15517-00	GEAR, IDLER 2 (76T)	1				
7	4NK-15590-00	STARTER ONE-WAY ASSY	1				
8	90110-08193	BOLT, HEXAGON SOCKET HEAD	6				
9	90201-350F3	WASHER, PLATE	1				

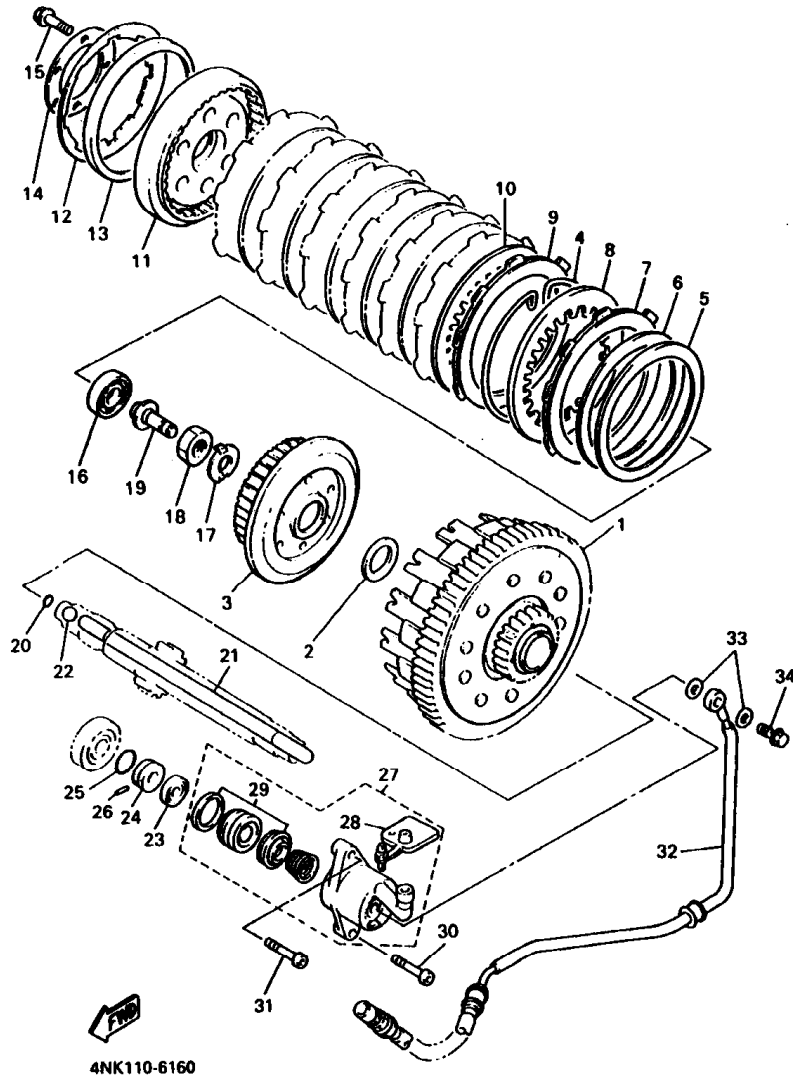

FIG. 15 CLUTCH

REF. NO.	PART NO.	DESCRIPTION	QTY	REMARKS
1	4NK-16150-01	PRIMARY DRIVEN GEAR COMP.	1	
2	26H-16154-00	PLATE, THRUST 1	1	
3	1FK-16371-00	BOSS, CLUTCH	1	
4	26H-16385-00	RING, CLUTCH BOSS	1	
5	26H-16384-00	PLATE, SEAT	1	
6	1FK-16383-00	SPRING, CLUTCH BOSS	1	
7	26H-16321-00	PLATE, FRICTION	1	
8	26H-16324-00	PLATE, CLUTCH 1	1	
9	26H-16307-00	PLATE, FRICTION 3	7	
10	26H-16324-00	PLATE, CLUTCH 1	6	
11	1FK-16351-00	PLATE, PRESSURE 1	1	
12	4NK-16334-00	SPRING, CLUTCH 2	1	
13	1FK-16335-00	HOUSING, SPRING	1	
14	1FK-16352-00	PLATE, PRESSURE 2	1	
15	97007-06025	BOLT	6	
16	93308-00304	BEARING (B6003C4)	1	
17	90215-25218	WASHER, LOCK	1	
18	90170-20323	NUT	1	
19	4KG-16356-00	ROD, PUSH 1	1	
20	93210-06632	O-RING	1	
21	4NK-16357-00	ROD, PUSH 2	1	
22	93511-32017	BALL	1	
23	93109-08061	OIL SEAL	1	
24	26H-16399-00	GUIDE, PUSH ROD	1	
25	93210-18322	O-RING	1	
26	93603-07073	PIN, DOWEL	1	
27	1FK-16381-11	PUSH LEVER COMP.	1	

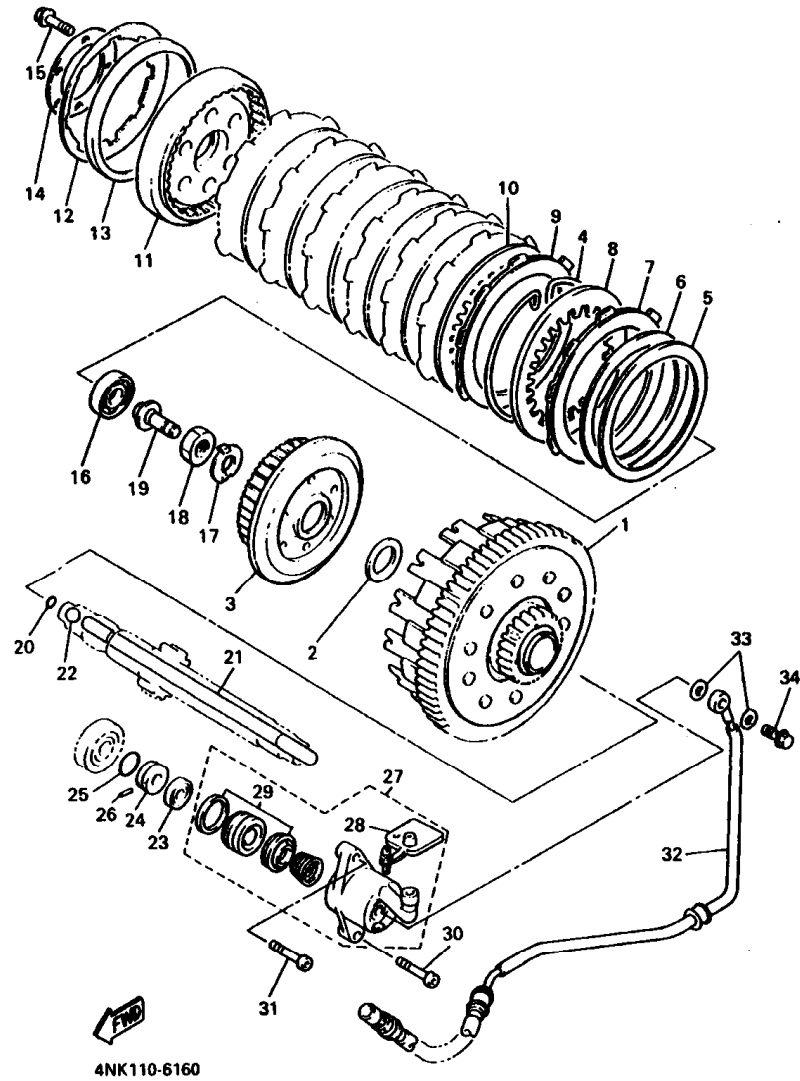

FIG. 15 CLUTCH

REF. NO.	PART NO.	DESCRIPTION	4YF3				REMARKS
28	1NL-W0048-00	.BLEED SCREW KIT	1				
29	26H-W0098-00	.PUSH LEVER SEAL KIT	1				
30	90110-06035	BOLT, HEXAGON SOCKET HEAD	1				
31	90110-06243	BOLT, HEXAGON SOCKET HEAD	1				
32	4NK-1638A-00	PIPE, CLUTCH 1	1				
33	90201-10118	WASHER, PLATE	2				
34	90401-10188	BOLT, UNION	1				

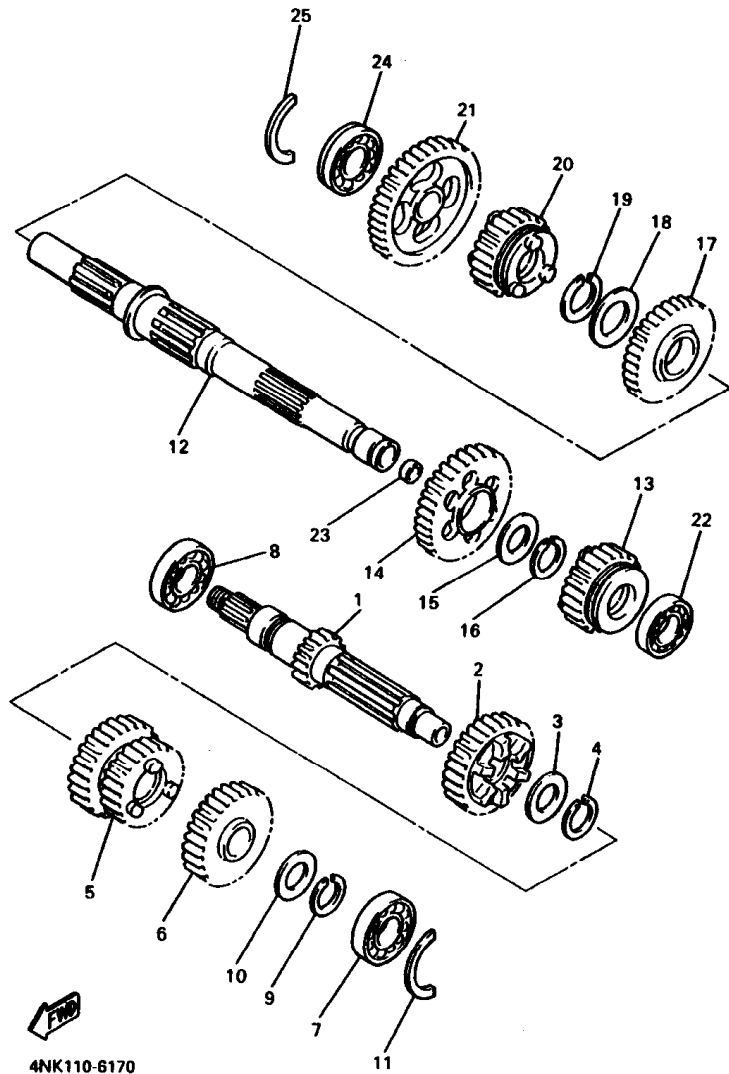
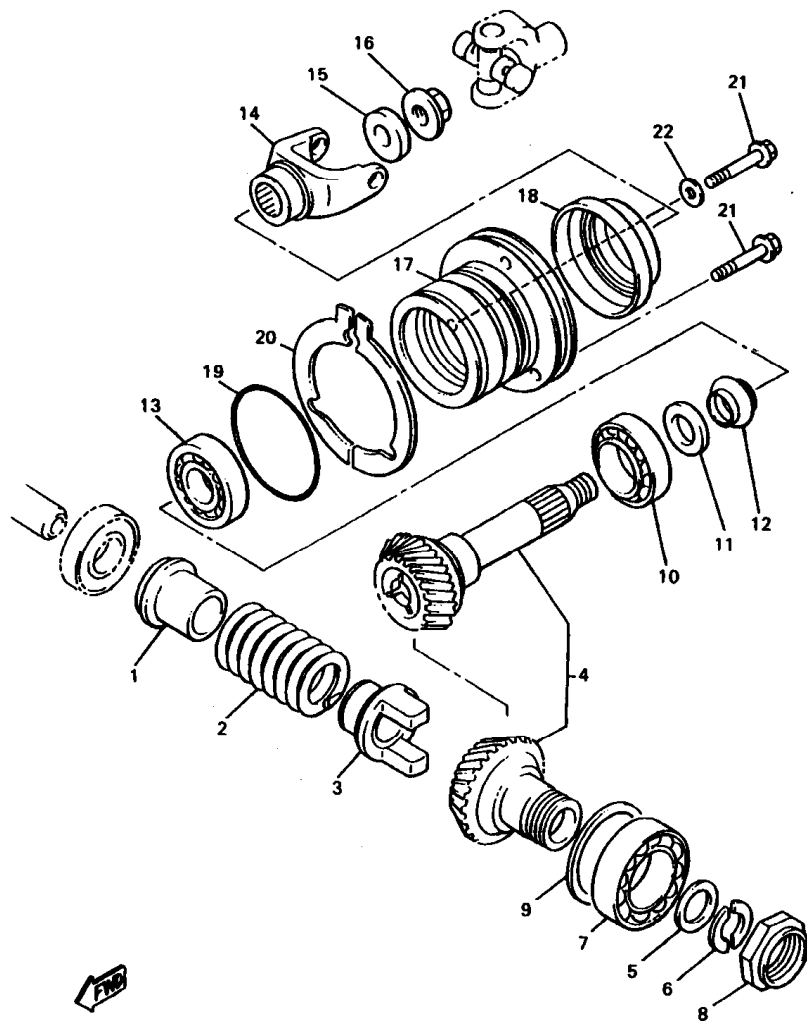

FIG. 16 TRANSMISSION

REF. NO.	PART NO.	DESCRIPTION	QTY	REMARKS
1	4NK-17411-01	AXLE, MAIN (16T)	1	
2	4NK-17141-01	GEAR, 4TH PINION (32T)	1	
3	90209-25196	WASHER	1	
4	93440-28062	CIRCLIP	1	
5	4NK-17121-01	GEAR, 2ND/3RD PINION (19/25T)	1	
6	4NK-17151-00	GEAR, 5TH PINION (28T)	1	
7	93306-30430	BEARING	1	
8	93306-36401	BEARING	1	
9	93410-23056	CIRCLIP	1	
10	90201-232K5	WASHER, PLATE	1	
11	93440-52118	CIRCLIP	1	
12	4NK-17421-00	AXLE, DRIVE	1	
13	4NK-17251-00	GEAR, 5TH WHEEL (21T)	1	
14	4NK-17221-01	GEAR, 2ND WHEEL (30T)	1	
15	90209-32231	WASHER	1	
16	93440-34025	CIRCLIP	1	
17	4NK-17231-01	GEAR, 3RD WHEEL (29T)	1	
18	90209-27192	WASHER	1	
19	93440-30077	CIRCLIP	1	
20	4NK-17241-01	GEAR, 4TH WHEEL (29T)	1	
21	4NK-17211-01	GEAR, 1ST WHEEL (39T)	1	
22	93306-20645	BEARING	1	
23	90331-15039	PLUG	1	
24	93306-20555	BEARING	1	
25	93440-52118	CIRCLIP	1	



4NK110-6180

FIG. 17 MIDDLE DRIVE GEAR

REF. NO.	PART NO.	DESCRIPTION	4/P3		REMARKS
1	2WE-17524-00	HOLDER	1		
2	90501-75638	SPRING, COMPRESSION	1		
3	2WE-17527-00	CAM, DRIVEN	1		
4	26H-W1751-01	MIDDLE GEAR COMP.	1		
5	90201-252K4	WASHER, PLATE	1		
6	90209-21281	WASHER	2		
7	93306-20901	BEARING (B6209RSH2-C2)	1		
8	90179-44328	NUT	1		
9	4X7-17531-00-15	SHIM, PINION (0.15T)	1		UR
	4X7-17531-00-30	SHIM, PINION (0.30T)	1		UR
	4X7-17531-00-50	SHIM, PINION (0.50T)	1		UR
10	93332-00028	BEARING	1		
11	90201-25634	WASHER, PLATE	1		
12	2H7-17571-01	SPACER, EXPANSION	1		
13	93332-00024	BEARING	1		
14	26H-17558-00	YOKÉ, JOINT	1		
15	90201-166R6	WASHER, PLATE	1		
16	90179-16662	NUT	1		
17	26H-17551-00	HOUSING, BEARING	1		
18	93101-35085	OIL SEAL	1		
19	93210-71360	O-RING	1		
20	3UF-17531-00	SHIM, PINION (0.10T)	2		UR
	3UF-17531-10	SHIM, PINION (0.15T)	2		UR
	3UF-17531-20	SHIM, PINION (0.20T)	2		UR
	3UF-17531-30	SHIM, PINION (0.30T)	2		UR
	3UF-17531-40	SHIM, PINION (0.40T)	2		UR
	3UF-17531-50	SHIM, PINION (0.50T)	2		UR

D3

FIG. 18 SHIFT CAM. FORK

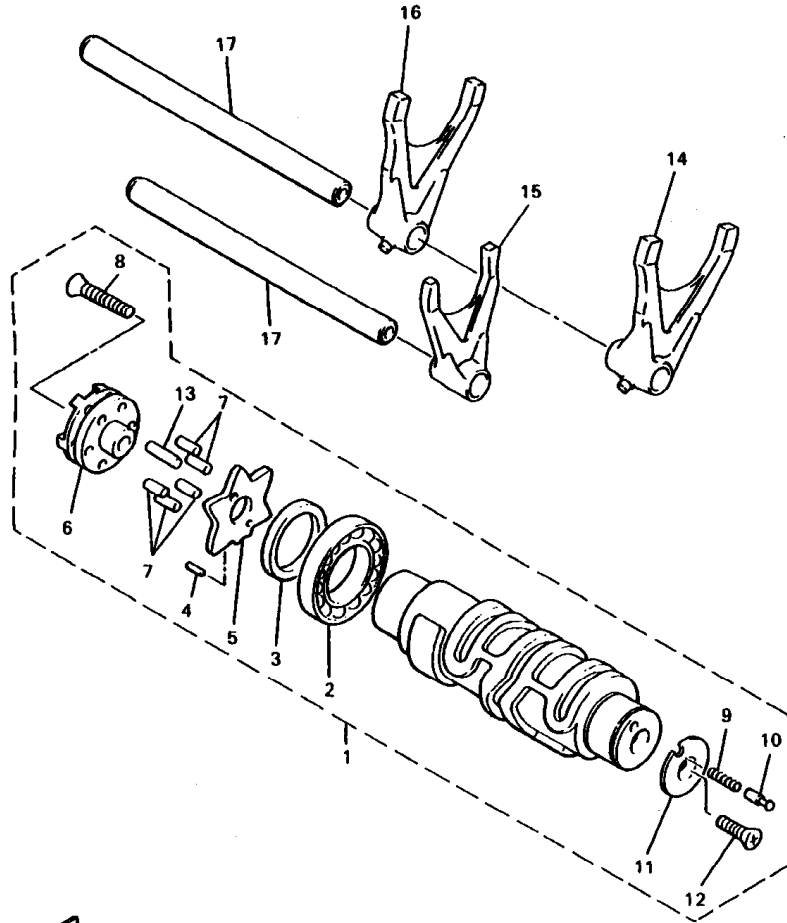

4NK7100-8190

REF. NO.	PART NO.	DESCRIPTION	AYP3	REMARKS
1	4NK-18540-03	SHIFT CAM ASSY	1	
2	93306-90602	.BEARING	1	
3	90560-30234	.SPACER	1	
4	93603-10049	.PIN, DOWEL	1	
5	4NK-18141-00	.PLATE, STOPPER	1	
6	4NK-18185-00	.SEGMENT	1	
7	93604-12037	.PIN, DOWEL	5	
8	90151-06013	.SCREW, COUNTERSUNK	1	
9	90501-06022	.SPRING, COMPRESSION	1	
10	4UN-18542-00	.POINT, NEUTRAL	1	
11	4UN-18566-00	.PLATE, SIDE 2	1	
12	90149-05321	.SCREW	1	
13	93604-16092	.PIN, DOWEL	1	
14	4NK-18511-00	FORK, SHIFT 1	1	
15	4NK-18512-00	FORK, SHIFT 2	1	
16	4NK-18513-00	FORK, SHIFT 3	1	
17	4NK-18531-00	BAR, SHIFT FORK GUIDE 1	2	

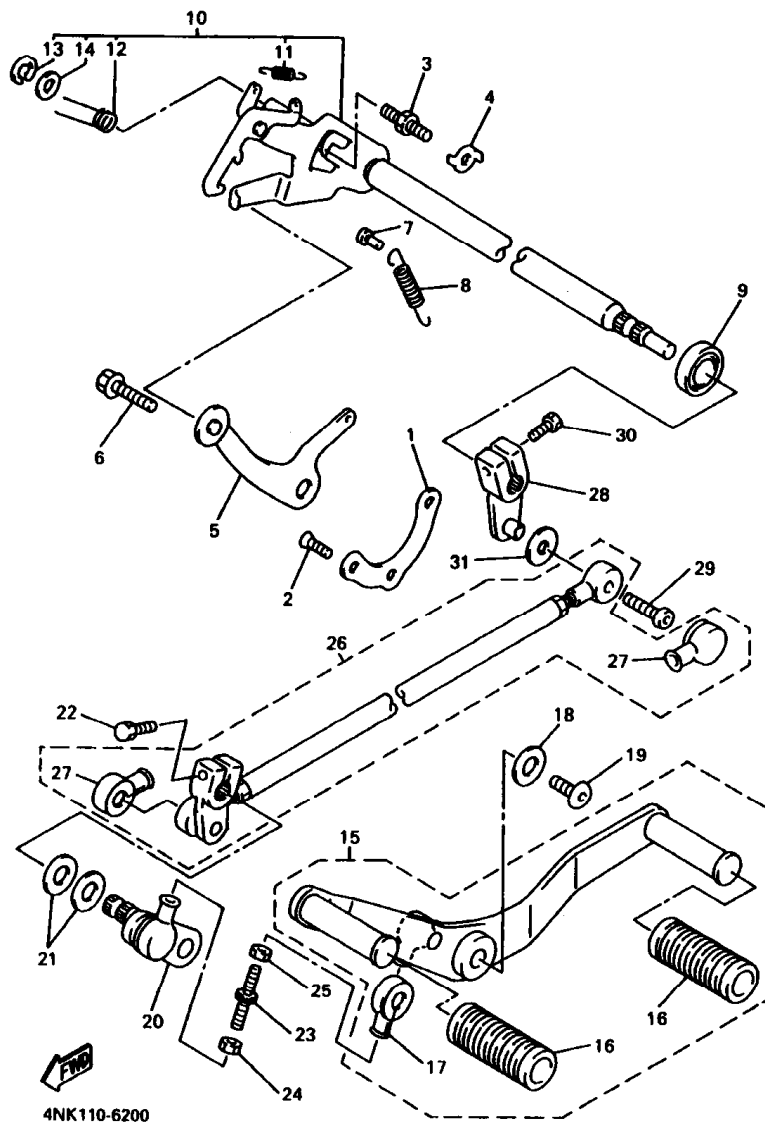

FIG. 19 SHIFT SHAFT

REF. NO.	PART NO.	DESCRIPTION	QTY	REMARKS
1	26H-18536-00	STOPPER, SHIFT BAR	1	
2	90151-08041	SCREW, COUNTERSUNK	3	
3	90109-08441	BOLT	1	
4	90215-08115	WASHER, LOCK	1	
5	26H-18140-01	STOPPER LEVER ASSY	1	
6	90109-063F8	BOLT	1	
7	132-16348-00	HOOK, SPRING	1	
8	90507-14064	SPRING, TENSION	1	
9	93102-14209	OIL SEAL	1	
10	4NK-18101-01	SHIFT SHAFT ASSY	1	
11	90508-08227	.SPRING, TENSION	1	
12	90508-32588	.SPRING, TORSION	1	
13	99001-10800	.CIRCLIP	1	
14	90201-127E1	.WASHER, PLATE	1	
15	4NK-18110-00	SHIFT PEDAL ASSY	1	
16	4NK-18113-00	.COVER, SHIFT PEDAL	2	
17	2H9-18154-00	.COVER, DUST	1	
18	90201-08070	WASHER, PLATE	1	
19	90149-08280	SCREW	1	
20	4NK-18197-01	SHAFT	1	
21	90201-12688	WASHER, PLATE	2	
22	97024-08020	BOLT	1	
23	4NK-18115-00	ROD, SHIFT	1	
24	95304-08700	NUT	1	
25	90170-06228	NUT(COUNTER CLOCKWISE)	1	
26	4NK-18150-02	SHIFT LEVER ASSY	1	
27	2H9-18154-00	.COVER, DUST	2	

D6

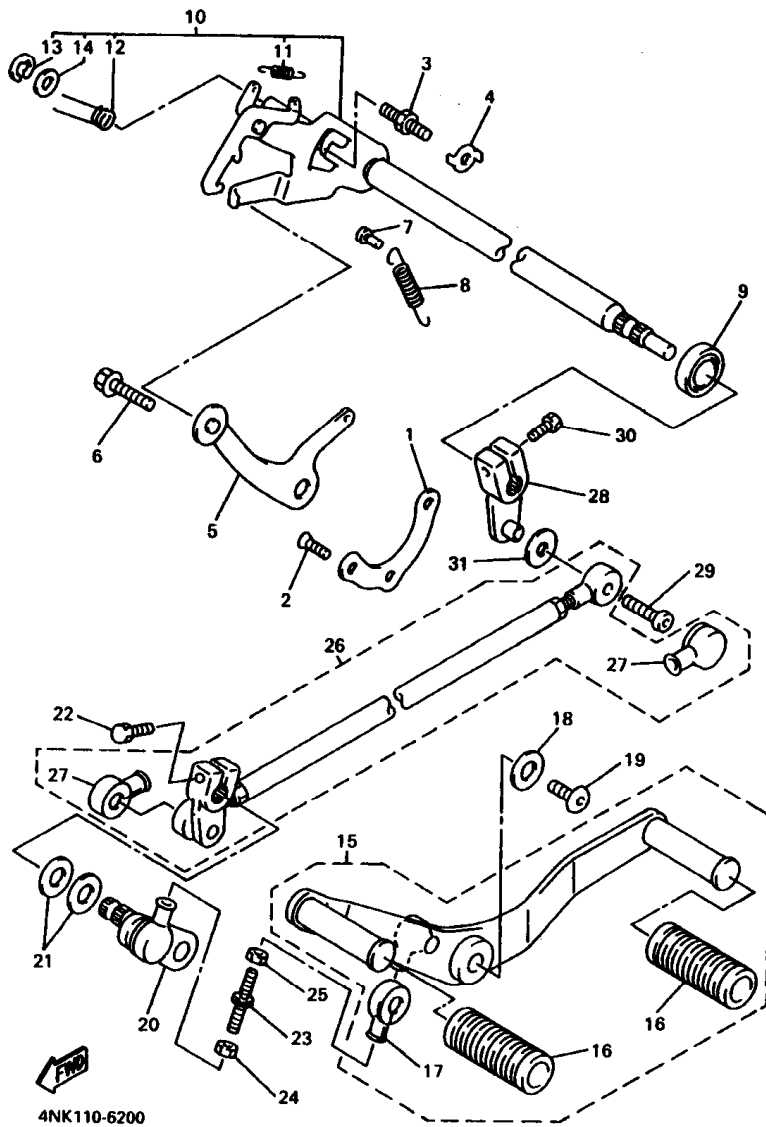

FIG. 19 SHIFT SHAFT

REF. NO.	PART NO.	DESCRIPTION	4YPS	REMARKS
28	4NK-18151-01	LEVER, SHIFT 3	1	
29	90149-06229	SCREW	1	
30	97027-06020	BOLT	1	
31	90201-06589	WASHER, PLATE	1	

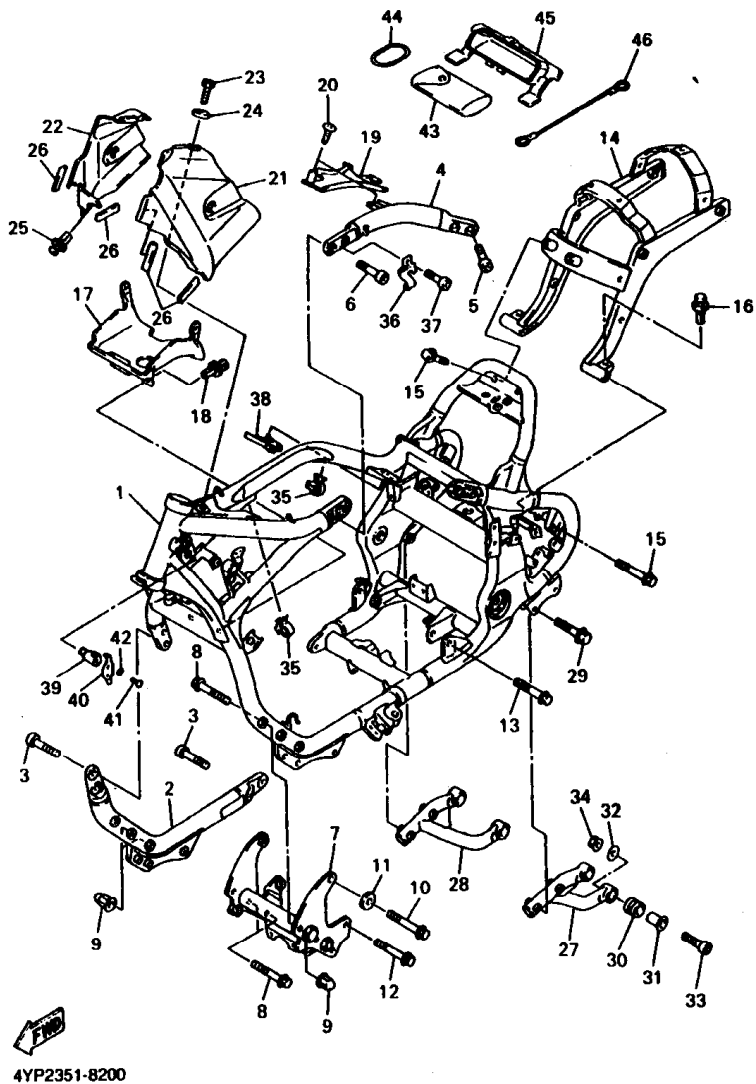
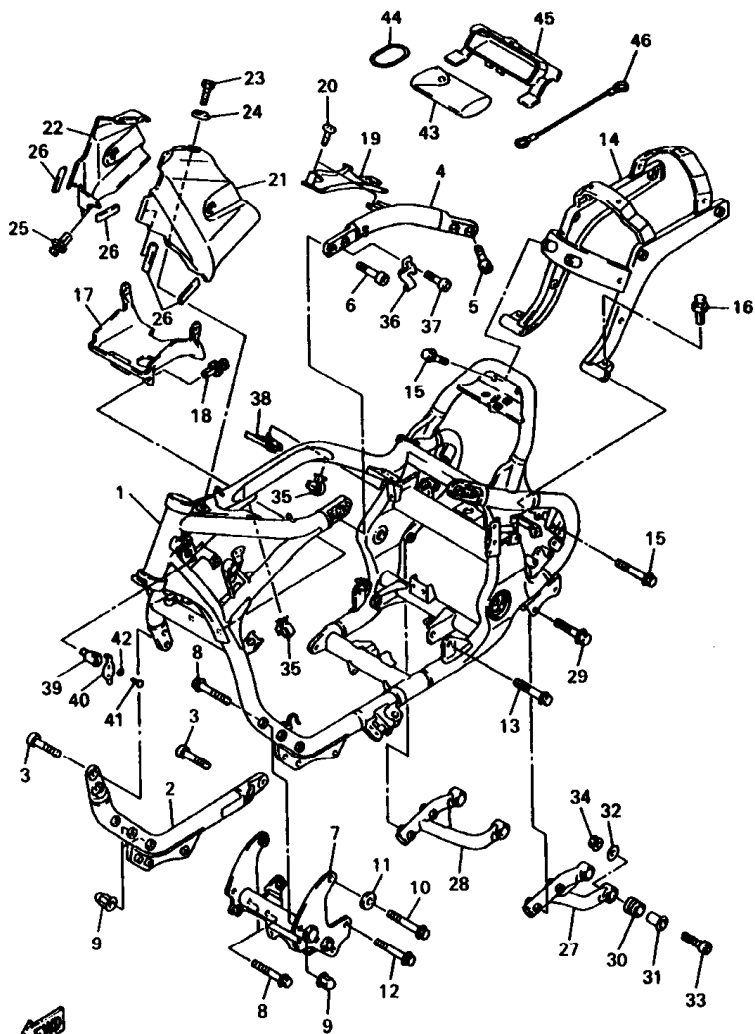

FIG. 20 FRAME

REF. NO.	PART NO.	DESCRIPTION	4YP3				REMARKS
1	4YP-21110-01-33	FRAME COMP.	1				YB
2	4NK-21150-00-33	DOWN TUBE COMP.2	1				YB
3	90110-10161	BOLT, HEXAGON SOCKET HEAD	4				
4	4NK-21120-00-33	FRAME, REAR	1				YB
5	90110-10161	BOLT, HEXAGON SOCKET HEAD	2				
6	90110-10191	BOLT, HEXAGON SOCKET HEAD	2				
7	4NK-2141V-00	CROSS BAR COMPLETE	1				
8	95827-10070	BOLT, FLANGE	6				
9	90176-10075	NUT, CROWN	6				
10	90105-10788	BOLT, WASHER BASED	2				
11	90209-12341	WASHER	2				
12	90105-10788	BOLT, WASHER BASED	2				
13	90105-12252	BOLT, WASHER BASED	2				
14	4XY-21190-00	REAR FRAME COMP.	1				
15	95827-10035	BOLT, FLANGE	4				
16	90269-07076	RIVET	2				
17	4NK-2117F-00	COVER	1				
18	90269-05049	RIVET	2				
19	4NK-2117M-01	COVER 2	1				
20	97707-60018	SCREW, TAPPING	1				
21	4NK-2171E-00-33	COVER, SIDE 5	1				YB
22	4NK-2171X-00-33	COVER, SIDE 6	1				YB
23	97007-05016	BOLT	1				
24	90209-06174	WASHER	1				
25	90269-07076	RIVET	2				
26	1LJ-2414J-00	DAMPER, PLATE 2	4				
27	4NK-21445-00	STAY, MUFFLER 1	1				



4YP2351-8200

FIG. 20 FRAME

REF. NO.	PART NO.	DESCRIPTION	4YP3				REMARKS
28	4NK-21446-00	STAY, MUFFLER 2	1				
29	90105-08310	BOLT, WASHER BASED	4				
30	36Y-27424-00	DAMPER, FOOTREST 2	4				
31	90387-104L8	COLLAR	4				
32	90201-105A2	WASHER, PLATE	4				
33	91317-10040	BOLT	4				
34	95317-10600	NUT	4				
35	90464-20191	CLAMP	2				
36	4NK-82594-00	CLAMP	1				
37	91317-06010	BOLT	1				
38	4NK-2117G-00	PROTECTOR	1				
39	*	STEERING LOCK ASSY	1				LM
40	134-23484-10	CAP, HANDLE LOCK	1				
41	90269-04003	RIVET	1				
42	90208-04029	WASHER, CONICAL SPRING	1				
43	4NK-28100-00	TOOL KIT	1				
44	93210-62446	O-RING	1				
45	4NK-28173-00	BOX, TOOL	1				
46	4YE-21398-00	HANGER, HELMET	1				

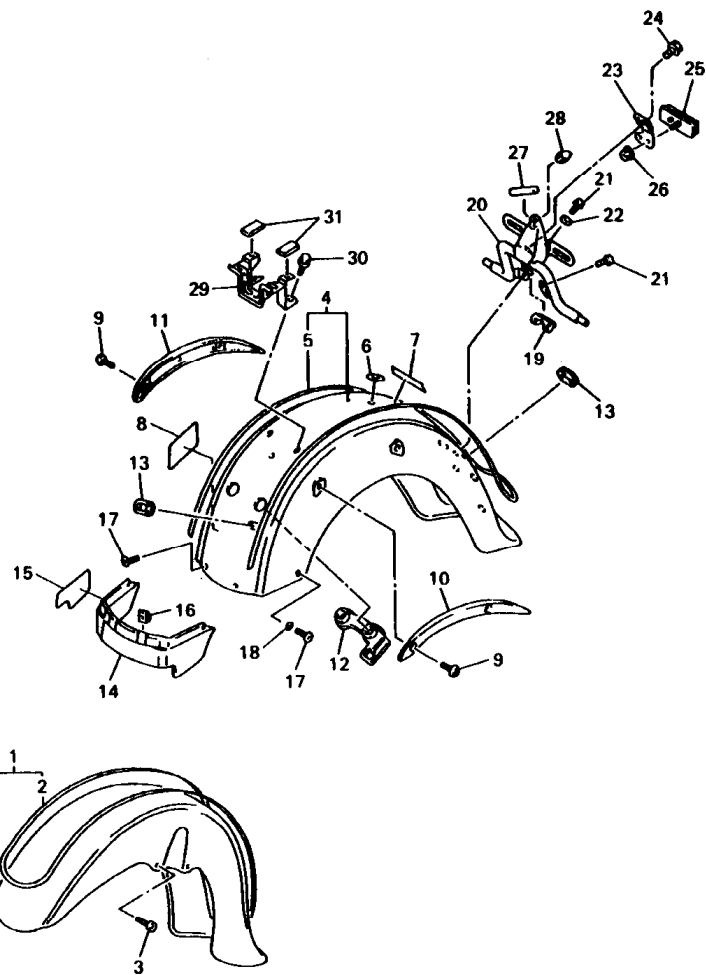

4YP2351-8210

FIG. 21 FENDER

REF. NO.	PART NO.	DESCRIPTION	4YPS	REMARKS
1	4NK-Y2150-F0-33	FRONT FENDER ASSY	1	UR YB
	4NK-Y2150-90-4X	FRONT FENDER ASSY	1	UR BCR/CMR
2	4YP-21570-00	.GRAPHIC SET, FRONT FENDER	1	UR FOR YB
	4NK-21570-50	.GRAPHIC SET, FRONT FENDER	1	UR FOR BCR
3	91314-08025	BOLT	4	
4	4NK-Y2161-H0-33	REAR FENDER COMP.	1	UR YB
	4NK-Y2161-E0-7X	REAR FENDER COMP.	1	UR BCR/CMR
5	4YP-2165A-00	.GRAPHIC SET, REAR FENDER	1	UR FOR YB
	4NK-2165A-50	.GRAPHIC SET, REAR FENDER	1	UR FOR BCR
6	4NK-21735-00	SEAL 2	1	
7	99237-00080	EMBLEM, YAMAHA	1	
8	4NK-21288-00	SEAL	1	
9	92014-08025	BOLT, BUTTON HEAD	4	
10	4NK-2164F-00	STAY 1	1	
11	4NK-2164G-00	STAY 2	1	
12	4NK-21649-00	DAMPER	1	
13	90480-15061	GROMMET	3	
14	4NK-21621-00-33	FLAP	1	UR YB
	4NK-21621-00-E9	FLAP	1	UR CMR FOR BCR
15	4NK-21289-00	SEAL	1	
16	90183-06053	NUT, SPRING	2	
17	90110-08200	BOLT, HEXAGON SOCKET HEAD	4	
18	90202-06170	WASHER, PLATE	2	
19	4NK-83345-00	PLUG, BLIND	1	
20	4YP-2317W-00	STAY, 9	1	
21	92014-06012	BOLT, BUTTON HEAD	3	
22	90201-06043	WASHER, PLATE	1	

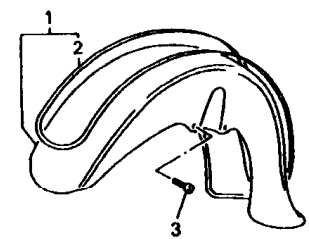
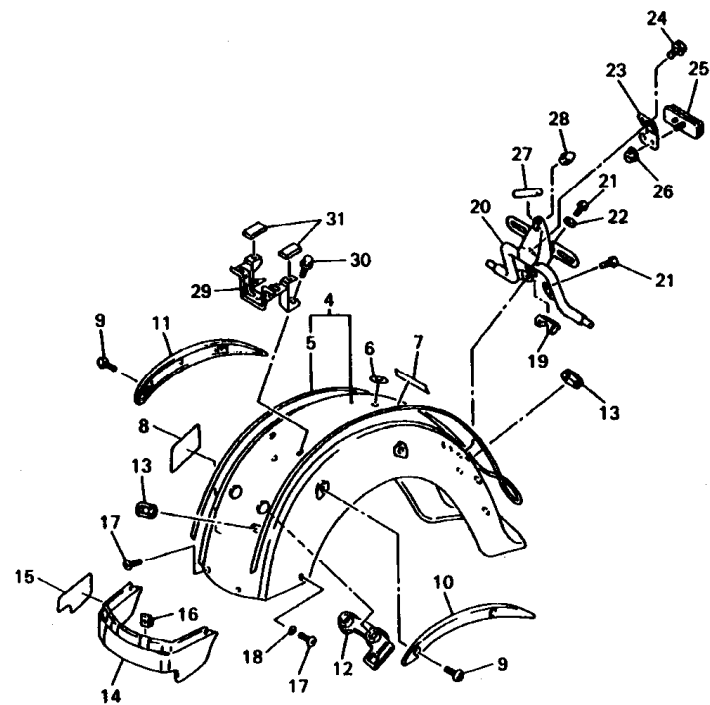

 4YP2351-8210

FIG. 21 FENDER

REF. NO.	PART NO.	DESCRIPTION	4YP3	REMARKS
23	4YP-21641-00	BRACKET, REFLECTOR	1	
24	95024-08010	BOLT, FLANGE	1	
25	3Y6-85130-02	REAR REFLECTOR ASSY	1	
26	95707-05500	NUT, FLANGE	1	
27	90446-07114	HOSE	1	
28	5A8-21639-00	DAMPER 2	1	
29	4NK-2475H-00	BRACKET, SEAT LEVER 1	1	
30	95027-08012	BOLT, FLANGE	3	
31	509-24724-00	DAMPER, SEAT	2	

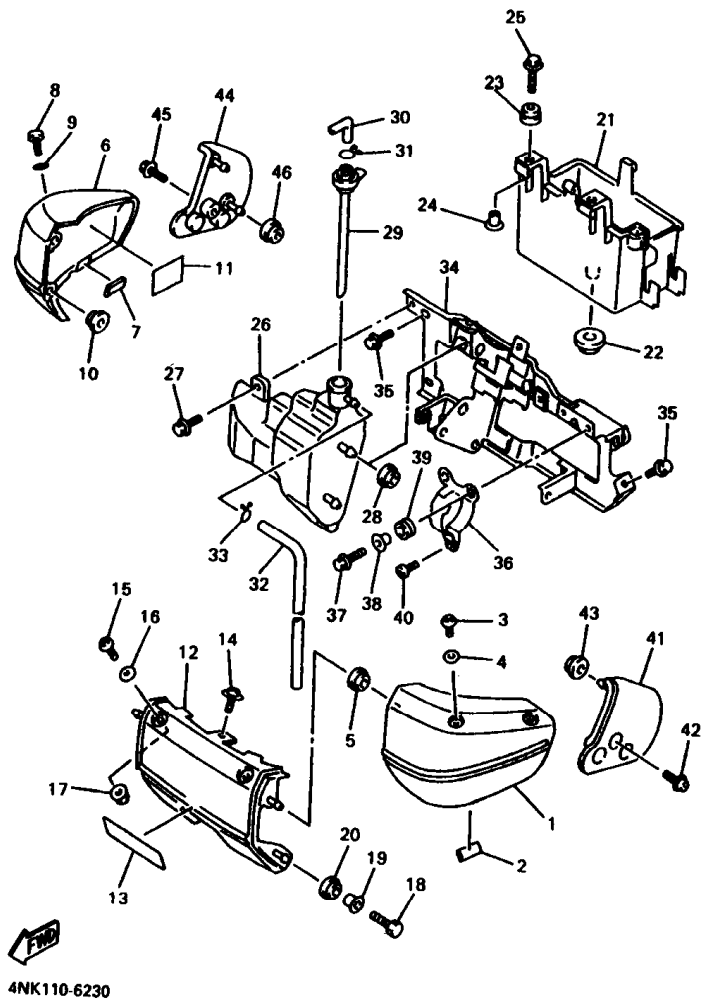

4NK110-6230

FIG. 22 SIDE COVER

REF. NO.	PART NO.	DESCRIPTION	4YF3		REMARKS
1	4NK-21711-00-33	COVER, SIDE 1	1		UR YB
	4NK-21711-00-FW	COVER, SIDE 1	1		UR BCR
2	51Y-21639-00	DAMPER 2	1		
3	90149-06298	SCREW	2		
4	90202-06172	WASHER, PLATE	2		
5	90480-13587	GROMMET	2		
6	4NK-21721-00-33	COVER, SIDE 2	1		UR YB
	4NK-21721-00-FW	COVER, SIDE 2	1		UR BCR
7	51Y-21639-00	DAMPER 2	1		
8	90149-06298	SCREW	2		
9	90202-06172	WASHER, PLATE	2		
10	90480-13587	GROMMET	2		
11	1JK-21735-00	SEAL 2	1		
12	4NK-2117X-00-33	COVER 9	1		UR YB
	4NK-2117X-00-FW	COVER 9	1		UR BCR
13	52W-2117G-00	PROTECTOR	1		
14	90159-08084	SCREW, WITH WASHER	1		
15	90149-06298	SCREW	2		
16	90202-06172	WASHER, PLATE	2		
17	95707-06500	NUT, FLANGE	2		
18	97007-06020	BOLT	2		
19	90387-067N5	COLLAR	2		
20	90480-13398	GROMMET	2		
21	4NK-2177G-00	BOX, BATTERY	1		
22	90480-20384	GROMMET	1		
23	90480-13398	GROMMET	2		
24	90387-067N5	COLLAR	2		

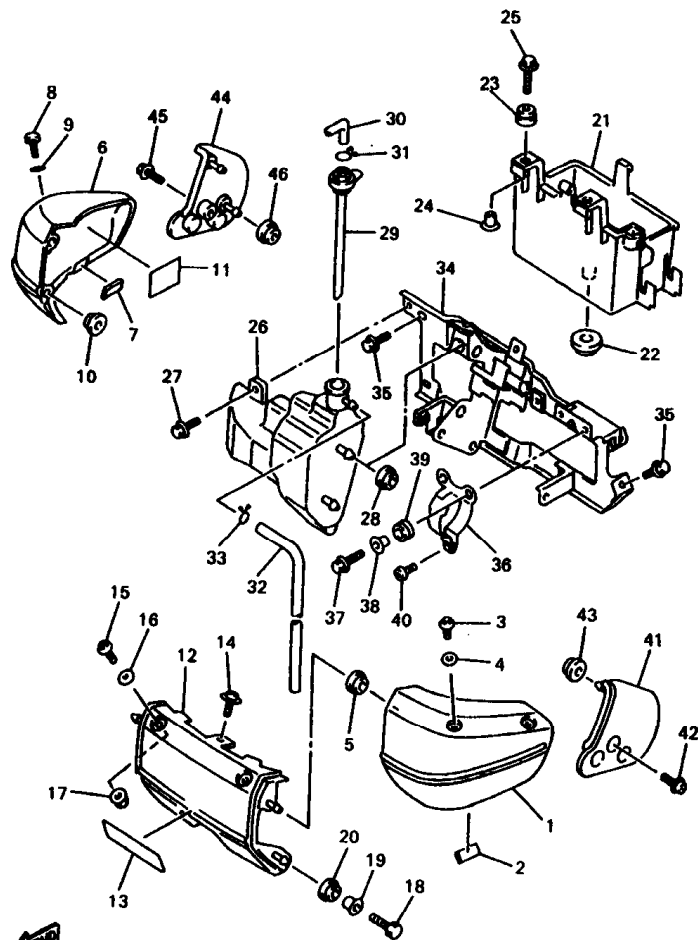

4NK110-6230

FIG. 22 SIDE COVER

REF. NO.	PART NO.	DESCRIPTION	4VP3	REMARKS
25	90119-06096	BOLT, WITH WASHER	2	
26	4NK-21871-00	TANK, RECOVERY	1	
27	90119-06044	BOLT, WITH WASHER	1	
28	90480-13567	GROMMET	2	
29	4NK-21875-00	CAP	1	
30	26H-21828-00	ELBOW	1	
31	90467-11019	CLIP	1	
32	90445-09117	HOSE	1	
33	90467-09006	CLIP	1	
34	4NK-21243-00	PLATE, BRIDGE	1	
35	95807-06010	BOLT, FLANGE	4	
36	3CV-24491-10	BRACKET, FUEL PUMP	1	
37	95817-06016	BOLT, FLANGE	2	
38	90387-062L2	COLLAR	2	
39	90480-13163	GROMMET	2	
40	98907-05010	SCREW, BIND	1	
41	4NK-21731-00	COVER, SIDE 3	1	
42	90159-06033	SCREW, WITH WASHER	1	
43	90480-13567	GROMMET	2	
44	4NK-21741-00	COVER, SIDE 4	1	
45	90159-06033	SCREW, WITH WASHER	1	
46	90480-13567	GROMMET	2	

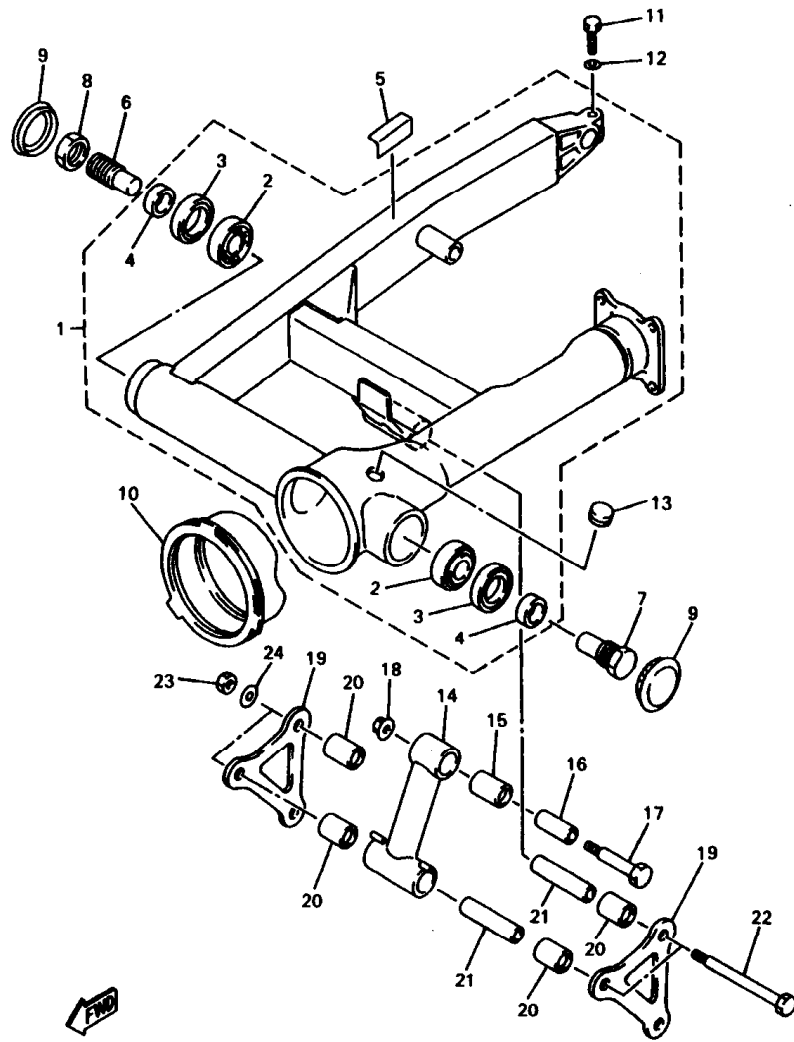

4NK110-6240

FIG. 23 REAR ARM

REF. NO.	PART NO.	DESCRIPTION	QTY	REMARKS
1	4NK-W2211-00-35	REAR ARM COMP.	1	SL
2	93332-00050	.BEARING (HR30204J)	2	UR
	93332-00051	.BEARING (HI-CAP3 0204JR)	2	UR
3	93106-28023	.OIL SEAL	2	
4	90387-204H5	.COLLAR	2	
5	2AL-84553-00	DAMPER	1	
6	4NK-2214H-00	SHAFT, PIVOT 2	1	
7	4NK-2214I-00	SHAFT, PIVOT	1	
8	26H-22143-00	NUT	1	
9	2H7-2219X-00	COVER	2	
10	26H-22189-00	BOOT, RUBBER	1	
11	97024-08025	BOLT	1	
12	92904-08600	WASHER	1	
13	90338-20113	PLUG	1	
14	4NK-2217A-00	ARM, RELAY	1	
15	93317-42060	BEARING	1	
16	90387-122J6	COLLAR	1	
17	90109-104E4	BOLT	1	
18	95607-10200	NUT, SELF-LOCKING	1	
19	4NK-2217M-00	ARM 1	2	
20	93317-41761	BEARING	4	
21	90387-128Y1	COLLAR	2	
22	90101-12749	BOLT	2	
23	90185-12119	NUT, SELF-LOCKING	2	
24	90201-128A7	WASHER, PLATE	2	

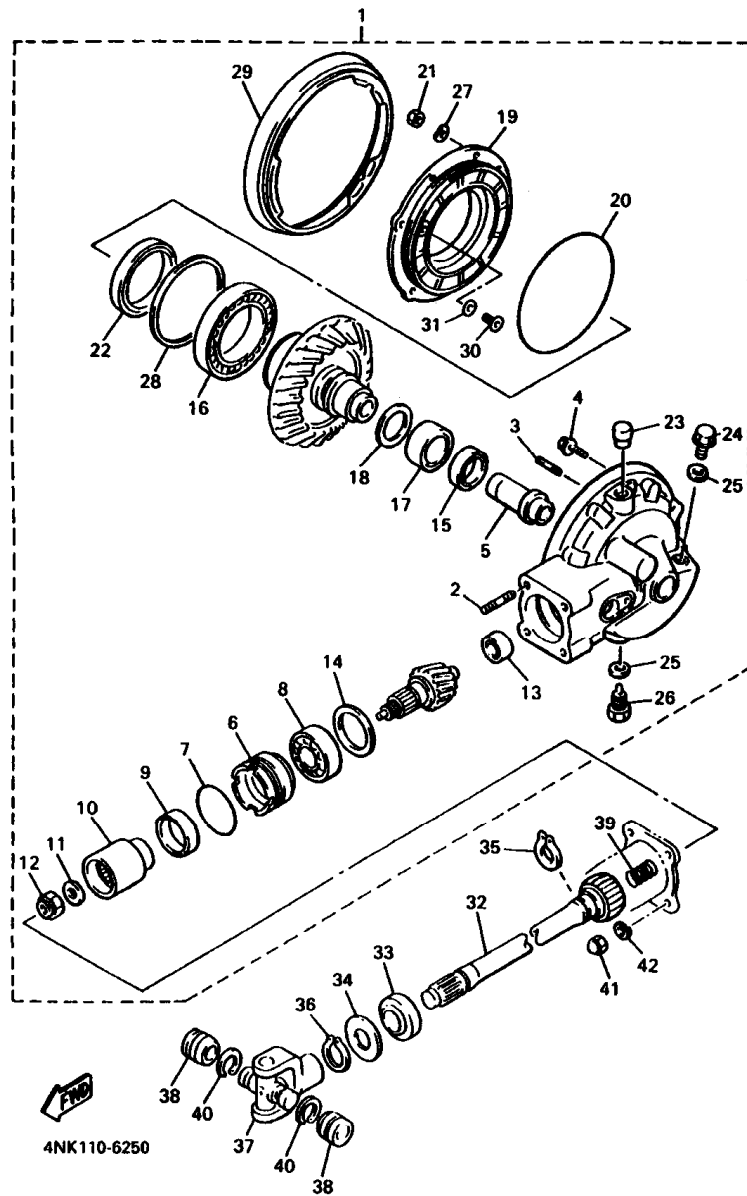

FIG. 24 DRIVE SHAFT

REF. NO.	PART NO.	DESCRIPTION	QTY	REMARKS
1	4YE-46101-00	REAR AXLE GEAR CASE ASSY	1	
2	90116-10593	.BOLT, STUD	4	
3	90116-08427	.BOLT, STUD	6	
4	95817-10050	.BOLT, FLANGE	2	
5	4YE-46153-00	.COLLAR, GUIDE	1	
6	4H7-46125-00	.RETAINER, BEARING	1	
7	93210-60426	.O-RING	1	
8	93306-30533	.BEARING (B6305RB1 SPECIAL)	1	
9	93101-38098	.OIL SEAL	1	
10	4H7-46123-01	.COUPLING, GEAR	1	
11	90201-166R5	.WASHER, PLATE	1	
12	90179-16661	.NUT	1	
13	2H7-46102-00	.BEARING ASSY	1	
14	1J7-17537-Y0-30	.SHIM, THRUST (0.30T)	1	UR
	1J7-17537-Y0-40	.SHIM, THRUST (0.40T)	1	UR
	1J7-17537-Y0-50	.SHIM, THRUST (0.50T)	1	UR
15	93101-30084	.OIL SEAL	1	
16	93316-01403	.BEARING	1	
17	93311-43729	.BEARING	1	
18	22U-46118-00-12	.SHIM, THRUST (1.2T)	1	UR
	22U-46118-00-14	.SHIM, THRUST (1.4T)	1	UR
	22U-46118-00-16	.SHIM, THRUST (1.6T)	1	UR
	22U-46118-00-18	.SHIM, THRUST (1.8T)	1	UR
	22U-46118-00-20	.SHIM, THRUST (2.0T)	1	UR
19	1FK-46152-01	.HOUSING, BEARING	1	
20	93211-54898	.O-RING	1	
21	95317-08600	.NUT	6	

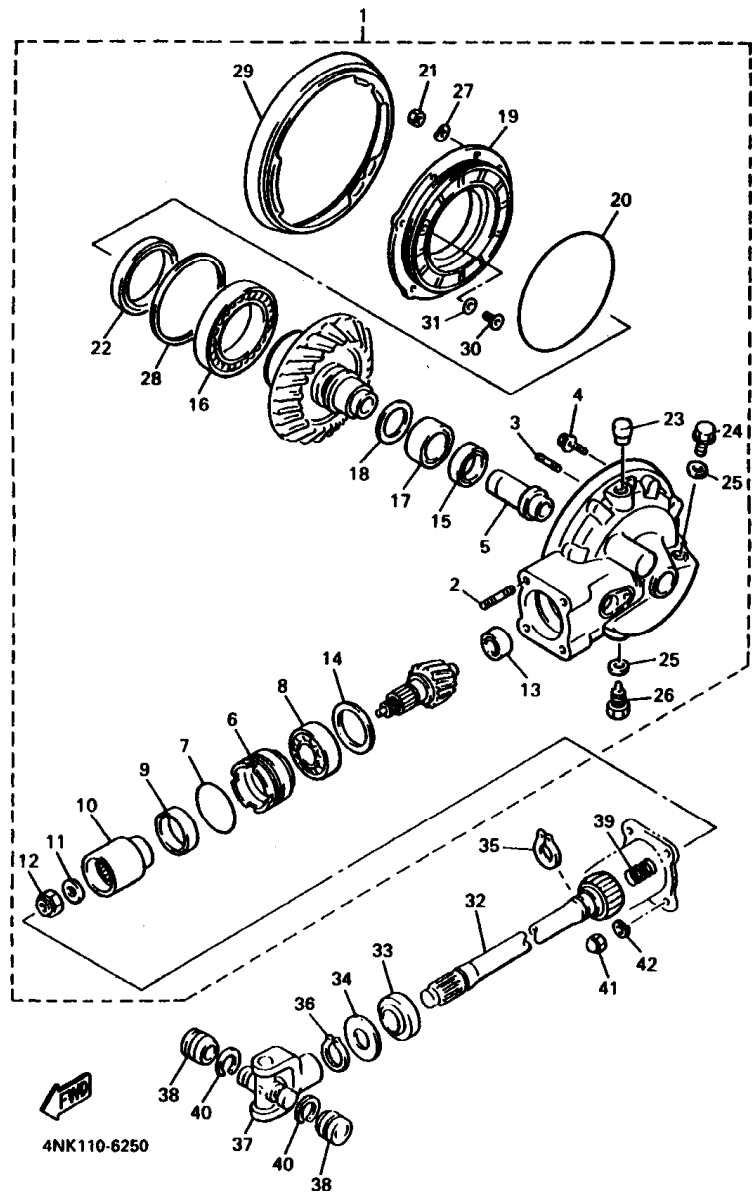
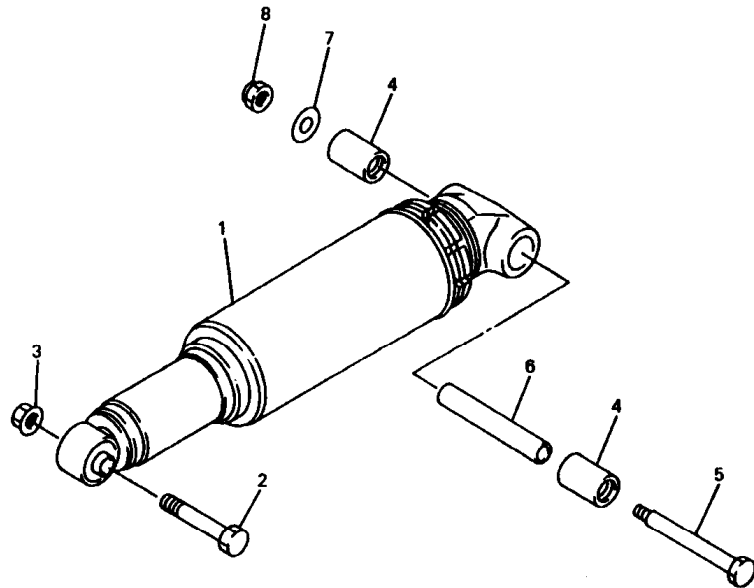

FIG. 24 DRIVE SHAFT

REF. NO.	PART NO.	DESCRIPTION	4YF3				REMARKS
22	93102-70167	.OIL SEAL	1				
23	56W-17590-00	.BREATHER COMP.	1				
24	90340-14132	.PLUG, STRAIGHT SCREW	1				
25	214-11198-01	.GASKET	2				
26	90340-14135	.PLUG, STRAIGHT SCREW	1				
27	92907-08700	.WASHER	6				
28	1J7-46117-Y0-30	.SHIM, RING GEAR (0.30T)	1				UR
	1J7-46117-Y0-40	.SHIM, RING GEAR (0.40T)	1				UR
	1J7-46117-Y0-50	.SHIM, RING GEAR (0.50T)	1				UR
29	1FK-46154-00	.COVER, HOUSING	1				
30	1FK-46156-00	.STOPPER, RING GEAR	1				
31	1FK-46157-00-15	.SHIM, STOPPER (T=0.15)	1				UR
	1FK-46157-00-20	.SHIM, STOPPER (T=0.20)	1				UR
32	4NK-46172-00	SHAFT, DRIVE	1				
33	93108-23007	OIL SEAL	1				
34	90201-231A2	WASHER, PLATE	1				
35	93410-23056	CIRCLIP	1				
36	93410-22039	CIRCLIP	1				
37	4X7-46180-00	CROSS JOINT COMP.	1				
38	93311-21044	BEARING	2				
39	90501-16491	SPRING, COMPRESSION	1				
40	93440-20088	CIRCLIP	2				
41	90176-10075	NUT, CROWN	4				
42	92903-10100	WASHER, SPRING	4				

FIG. 25 REAR SUSPENSION



4NK110-6260

REF. NO.	PART NO.	DESCRIPTION	4YFS				REMARKS
1	4YP-22210-00	SHOCK ABSORBER ASSY, REAR	1				
2	90101-12498	BOLT	1				
3	95607-12200	NUT, SELF-LOCKING	1				
4	93317-41761	BEARING	2				
5	90101-12749	BOLT	1				
6	90387-126Y1	COLLAR	1				
7	90201-126A7	WASHER, PLATE	1				
8	90185-12119	NUT, SELF-LOCKING	1				

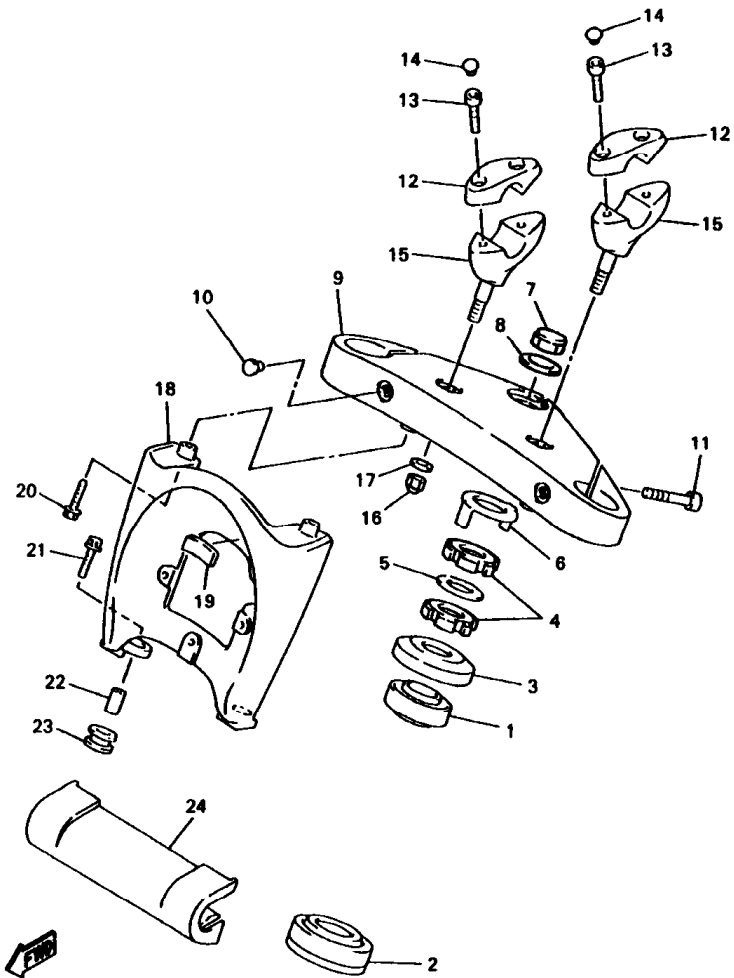

4NKA100-9270

FIG. 26 STEERING

REF. NO.	PART NO.	DESCRIPTION	QTY	REMARKS
1	93332-00001	BEARING	1	
2	93332-00008	BEARING	1	
3	1W1-23418-00	COVER, BALL RACE 2	1	
4	90179-25033	NUT	2	
5	90202-26142	WASHER, PLATE	1	
6	26H-23418-01	WASHER, SPECIAL	1	
7	90176-22081	NUT, CROWN	1	
8	90201-220T0	WASHER, PLATE	1	
9	4NK-23435-00	CROWN, HANDLE	1	
10	90338-09161	PLUG	2	
11	91314-08030	BOLT	4	
12	4NK-23441-00	HOLDER, HANDLE UPPER	2	
13	91314-08025	BOLT	4	
14	90338-08163	PLUG	4	
15	4NK-23442-00	HOLDER, HANDLE LOWER	2	
16	90176-12052	NUT, CROWN	2	
17	90201-122F8	WASHER, PLATE	2	
18	4NK-23437-00	COVER, CROWN	1	
19	1KT-21541-00	DAMPER 1	1	
20	95804-06025	BOLT, FLANGE	2	
21	95804-06035	BOLT, FLANGE	2	
22	90387-06605	COLLAR	2	
23	90480-16284	GROMMET	2	
24	4NK-23122-00	COVER, OUTER 1	1	

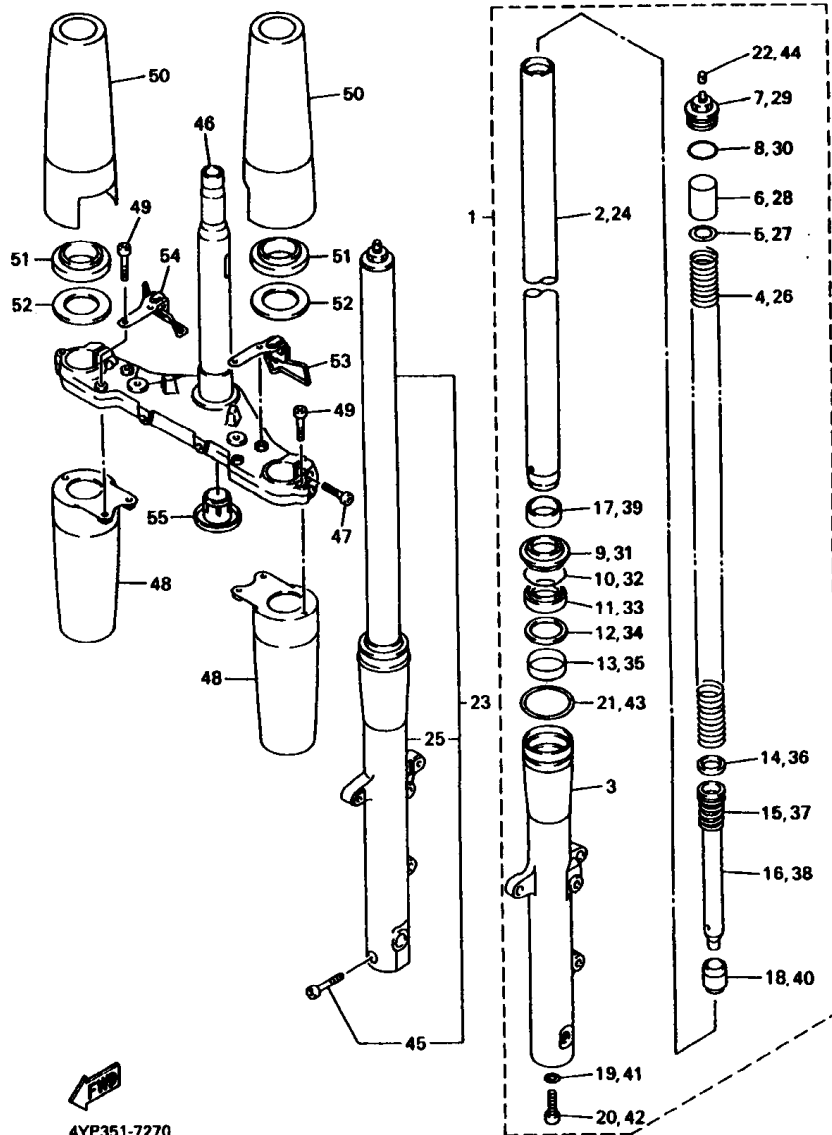

4YP351-7270

FIG. 27 FRONT FORK

REF. NO.	PART NO.	DESCRIPTION	4YP3				REMARKS
1	4YP-23102-00	FRONT FORK ASSY (L.H)	1				
2	4NK-23110-00	.INNER TUBE COMP.1	1				
3	4NK-23126-00	.TUBE, OUTER (LEFT)	1				
4	4NK-23141-01	.SPRING, FRONT FORK	1				
5	4NK-23142-00	.SEAT, SPRING UPPER	1				
6	4NK-23118-01	.SPACER	1				
7	4YP-23111-00	.BOLT, CAP	1				
8	4NK-23147-00	.O-RING	1				
9	4NK-23144-00	.SEAL, DUST	1				
10	34L-23153-00	.RING, SNAP	1				
11	4NK-23145-00	.OIL SEAL	1				
12	4NK-23146-00	.WASHER, OIL SEAL	1				
13	4NK-23125-00	.METAL, SLIDE 1	1				
14	4NK-23157-00	.RING, PISTON	1				
15	4NK-23151-00	.SPRING, REBOUND	1				
16	4NK-23171-00	.PISTON, FRONT FORK	1				
17	4NK-23135-00	.METAL, SLIDE 2	1				
18	4NK-23166-00	.SPACER, OIL LOCK	1				
19	3MA-23129-10	.GASKET, DRAIN PLUG	1				
20	4NK-23181-00	.BOLT, HEXAGON SOCKET HEAD	1				
21	4NK-23193-00	.GUIDE, BOOT	1				
22	4V1-23184-L0	.CAP, AIR VALVE	1				
23	4YP-23103-00	FRONT FORK ASSY (R.H)	1				
24	4NK-23110-00	.INNER TUBE COMP.1	1				
25	4NK-23136-00	.TUBE, OUTER (RIGHT)	1				
26	4NK-23141-01	.SPRING, FRONT FORK	1				
27	4NK-23142-00	.SEAT, SPRING UPPER	1				

FIG. 27 FRONT FORK

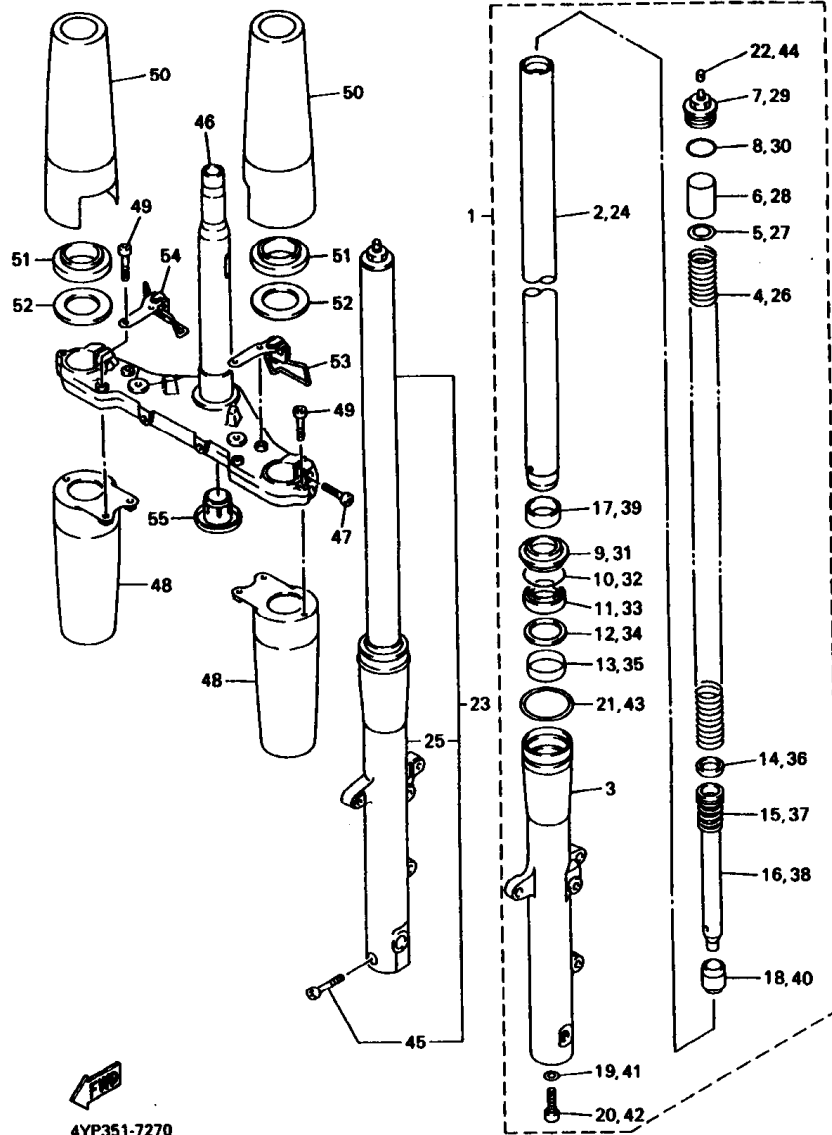

4YP351-7270

REF. NO.	PART NO.	DESCRIPTION	4YP3				REMARKS
28	4NK-23118-01	.SPACER	1				
29	4YP-23111-00	.BOLT, CAP	1				
30	4NK-23147-00	.O-RING	1				
31	4NK-23144-00	.SEAL, DUST	1				
32	34L-23153-00	.RING, SNAP	1				
33	4NK-23145-00	.OIL SEAL	1				
34	4NK-23148-00	.WASHER, OIL SEAL	1				
35	4NK-23125-00	.METAL, SLIDE 1	1				
36	4NK-23157-00	.RING, PISTON	1				
37	4NK-23151-00	.SPRING, REBOUND	1				
38	4NK-23171-00	.PISTON, FRONT FORK	1				
39	4NK-23135-00	.METAL, SLIDE 2	1				
40	4NK-23166-00	.SPACER, OIL LOCK	1				
41	3MA-23129-10	.GASKET, DRAIN PLUG	1				
42	4NK-23181-00	.BOLT, HEXAGON SOCKET HEAD	1				
43	4NK-23193-00	.GUIDE, BOOT	1				
44	4V1-23184-L0	.CAP, AIR VALVE	1				
45	1KT-23181-00	.BOLT, HEXAGON SOCKET HEAD	1				
46	4YP-23340-00	UNDER BRACKET COMP.	1				
47	38W-23181-00	BOLT, HEXAGON SOCKET HEAD	4				
48	4NK-23123-00	COVER, LOWER 1	2				
49	4NK-23181-10	BOLT, HEXAGON SOCKET HEAD	6				
50	4NK-23121-00	COVER, UPPER 1	2				
51	4NK-23163-00	GASKET	2				
52	4NK-23165-00	WASHER, FELT	2				
53	4NK-2331E-00	GUIDE, CABLE	1				
54	4NK-23389-00	GUIDE, CABLE	1				

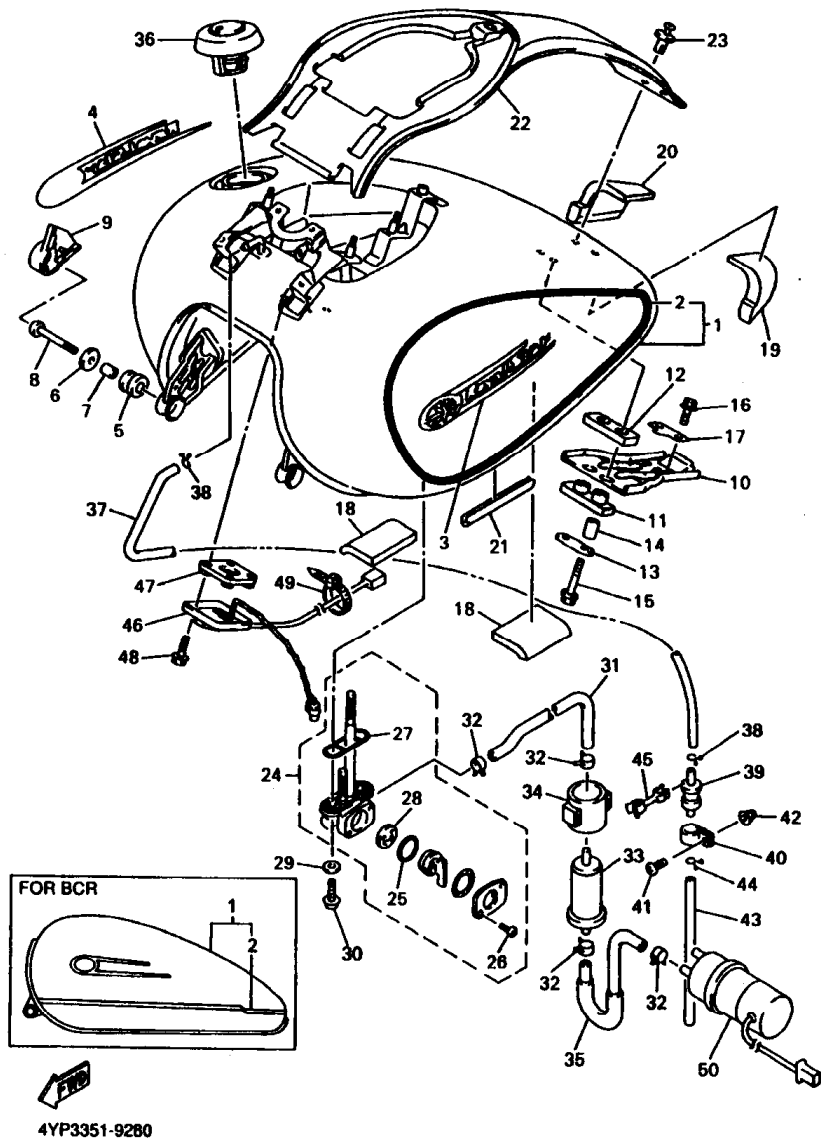

FIG. 28 FUEL TANK

REF. NO.	PART NO.	DESCRIPTION	4YP3		REMARKS
1	4NK-Y2410-10-01	FUEL TANK COMP.	1		UR YB
	4NK-Y2410-10-02	FUEL TANK COMP.	1		UR BCR/CMR
2	4YP-24240-01	.GRAPHIC SET	1		UR FOR YB
	4YE-24240-50	.GRAPHIC SET	1		UR FOR BCR
3	4NK-24161-00	EMBLEM 1	1		
4	4NK-24162-00	EMBLEM 2	1		
5	90480-18354	GROMMET	2		
6	90201-06071	WASHER, PLATE	2		
7	90387-06027	COLLAR	2		
8	92017-06035	BOLT, BUTTON HEAD	2		
9	4NK-24129-00	COVER, SIDE 1	2		
10	4NK-24191-00	BRACKET, FUEL TANK 1	1		
11	2GH-24181-00	DAMPER, LOCATING 1	1		
12	2GH-24183-00	DAMPER, LOCATING 3	1		
13	2GH-24186-00	WASHER, SPECIAL	1		
14	90387-06299	COLLAR	2		
15	95807-06025	BOLT, FLANGE	2		
16	95827-06014	BOLT, FLANGE	2		
17	4NK-24186-00	WASHER, SPECIAL	1		
18	4NK-24181-00	DAMPER, LOCATING 1	2		
19	4NK-24182-00	DAMPER, LOCATING 2	1		
20	4NK-24183-00	DAMPER, LOCATING 3	1		
21	31A-24188-01	MOLD, FUEL TANK	1		
22	4NK-2171A-00	COVER, TOP	1		
23	90269-07076	RIVET	2		
24	2GU-24500-01	FUEL COCK ASSY 1	1		
25	3AJ-24534-00	.SEAL, COCK	1		

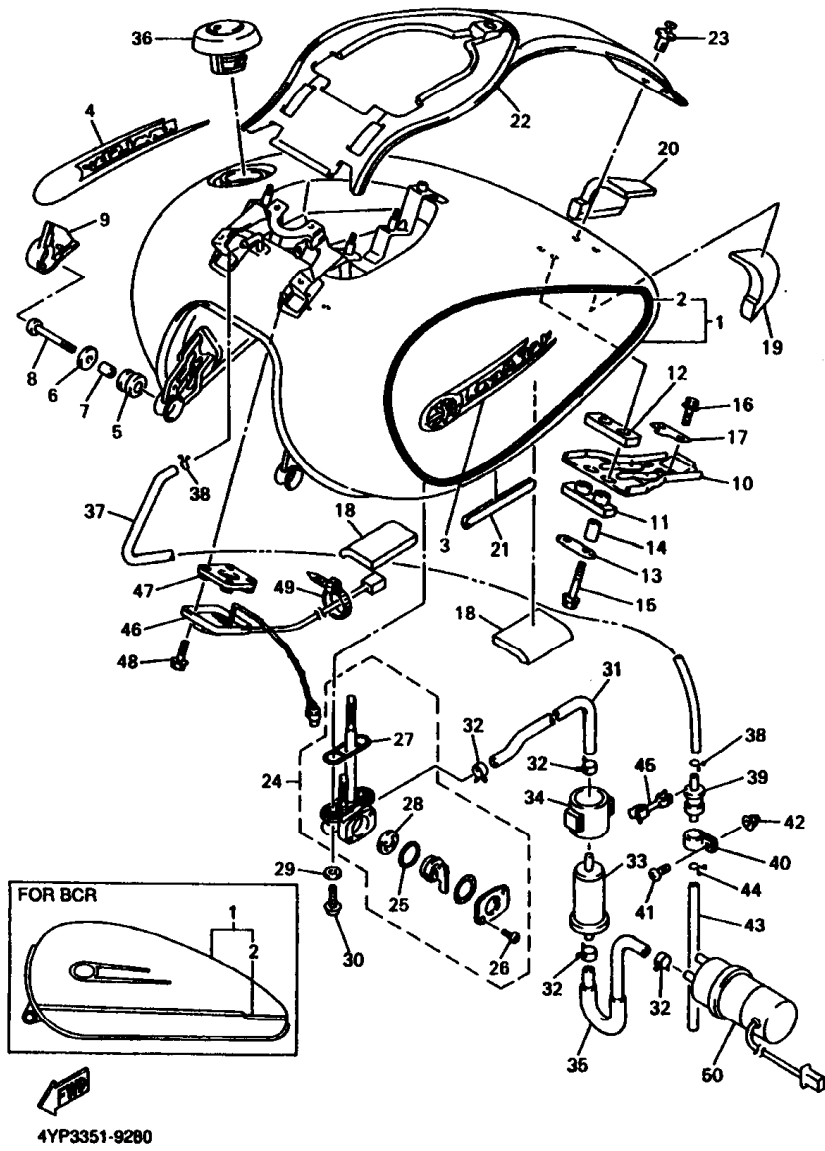
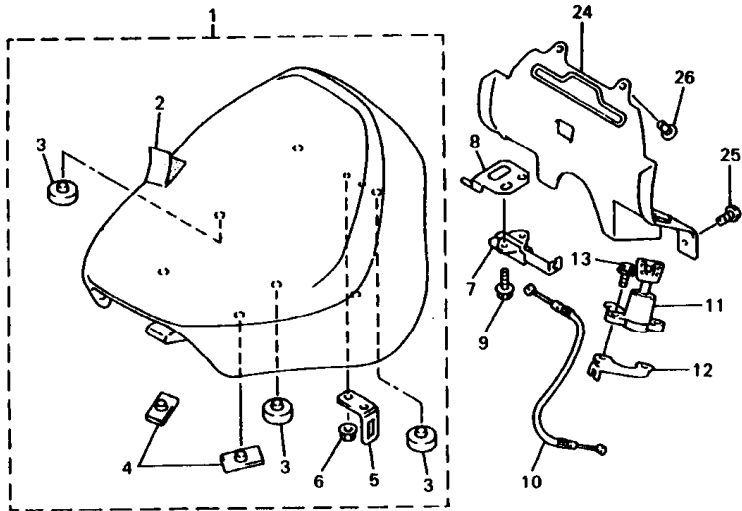
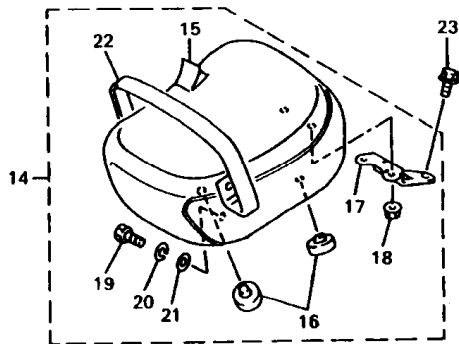

FIG. 28 FUEL TANK

REF. NO.	PART NO.	DESCRIPTION	4YPS				REMARKS
26	97801-03008	.SCREW, PAN HEAD	2				
27	4X8-24512-00	.O-RING	1				
28	3AJ-24523-00	.VALVE PACKING	1				
29	90202-05193	WASHER, PLATE	2				
30	90149-06011	SCREW	2				
31	4NK-24311-00	PIPE, FUEL 1	1				
32	90467-12053	CLIP	4				
33	1FK-24560-00	FILTER ASSY	1				
34	1FK-24566-00	BRACKET, FILTER	1				
35	4NK-24312-00	PIPE 2	1				
36	4NK-24802-10	CAP ASSY	1				
37	4NK-24321-01	PIPE 10	1				
38	90467-10041	CLIP	2				
39	25H-24180-00	ROLL OVER VALVE ASSY	1				
40	90461-15100	CLAMP	1				
41	98907-05012	SCREW, BIND	1				
42	90178-05054	NUT, CROWN	1				
43	90445-112K5	HOSE	1				
44	90467-10041	CLIP	1				
45	90464-13103	CLAMP	2				
46	4NK-85752-01	SENDER UNIT ASSY, FUEL METER	1				
47	5G3-85753-00	GASKET, SENDER UNIT	1				
48	90119-05071	BOLT, WITH WASHER	4				
49	90464-13073	CLAMP	1				
50	4NK-13907-00	FUEL PUMP COMP.	1				



4YP351-7290

FIG. 29 SEAT

REF. NO.	PART NO.	DESCRIPTION	4YP3	REMARKS
1	4NL-24710-00	SINGLE SEAT ASSY	1	
2	4NL-24711-00	.COVER, SINGLE SEAT	1	
3	22W-24741-00	.PAD, SEAT	5	
4	509-24724-00	.DAMPER, SEAT	2	
5	4NK-24728-00	.BRACKET, SEAT	1	
6	95707-06500	.NUT, FLANGE	2	
7	50W-24705-01	SEAT LOCK ASSY	1	
8	4NK-24792-00	PLATE	1	
9	95807-06014	BOLT, FLANGE	2	
10	4NK-2478E-00	CABLE, SEAT LOCK	1	
11	3CK-W2470-00	SEAT LOCK ASSY	1	
12	4NK-2478X-00	BRACKET, SEAT LOCK	1	
13	95027-06012	BOLT, FLANGE	2	
14	4YP-24750-00	TANDEM SEAT ASSY	1	
15	4NL-24751-00	.COVER, TANDEM SEAT	1	
16	22W-24741-00	.PAD, SEAT	3	
17	4NK-2471A-00	.STAY, SEAT	1	
18	95707-06500	.NUT, FLANGE	2	
19	97007-06020	.BOLT	2	
20	92907-06100	.WASHER, SPRING	2	
21	90201-06765	.WASHER, PLATE	2	
22	4YP-24754-00	.HOOK, SEAT	1	
23	95024-08012	BOLT, FLANGE	1	
24	4NK-24796-00	COVER	1	
25	90110-05201	BOLT, HEXAGON SOCKET HEAD	2	
26	90269-06046	RIVET	2	

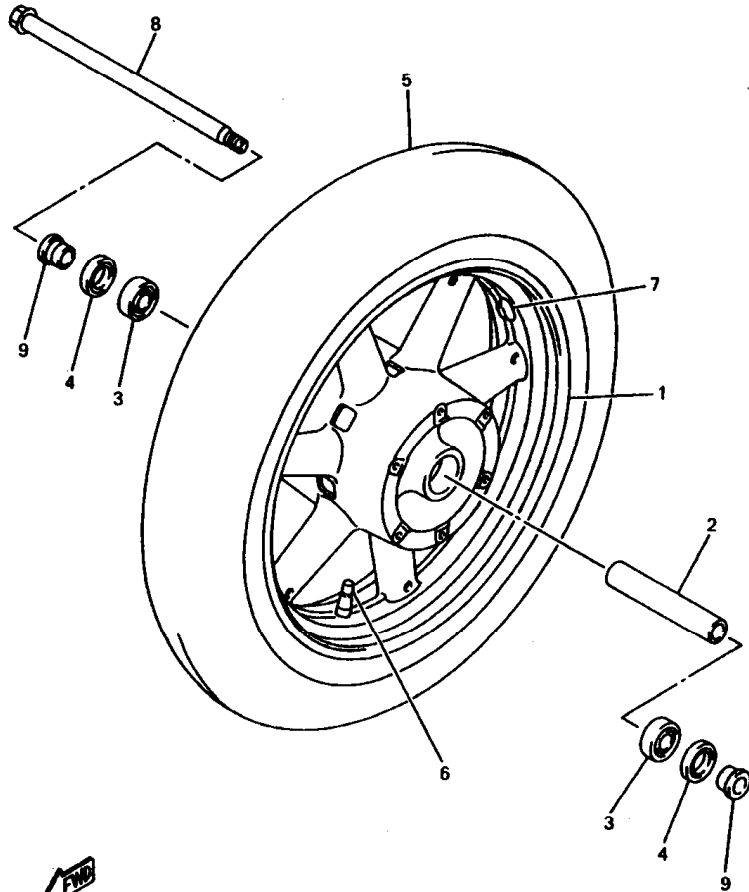

4NK110-6310

FIG. 30 FRONT WHEEL

REF. NO.	PART NO.	DESCRIPTION	QTY	REMARKS
1	4NK-25168-00-WG	CAST WHEEL, FRONT	1	HTS
2	90387-2208J	COLLAR	1	
3	93306-00420	BEARING (B6004)	2	
4	93102-28021	OIL SEAL	2	
5	94115-1811R	TIRE (150/80-16 71H D404F)	1	DUNLOP
6	93900-00030	VALVE, RIM	1	
7	29L-25398-00	BALANCER, WHEEL (10G)	1	UR
	29L-25398-10	BALANCER, WHEEL (20G)	1	UR
	29L-25398-20	BALANCER, WHEEL (30G)	1	UR
8	4NK-25181-00	AXLE, WHEEL	1	
9	90387-2200T	COLLAR	2	

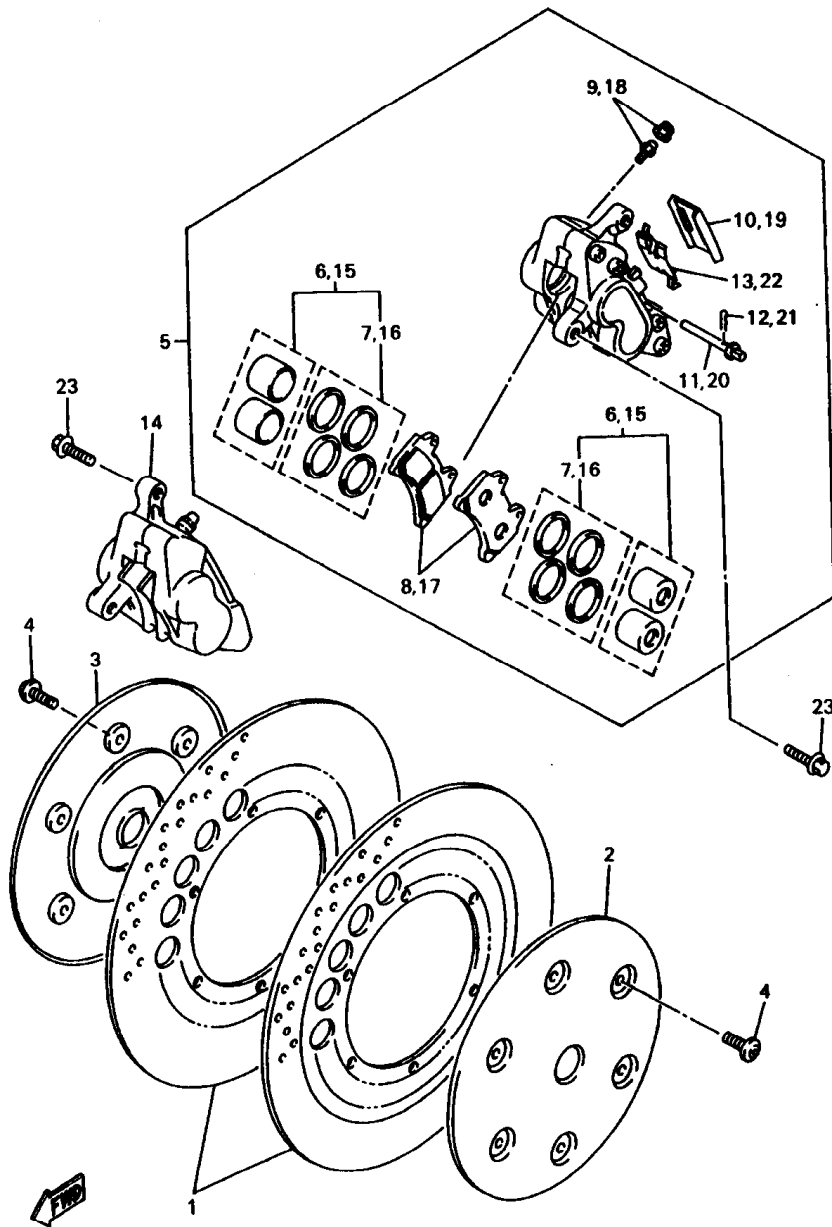

4NK110-6320

FIG. 31 FRONT BRAKE CALIPER

REF. NO.	PART NO.	DESCRIPTION	QTY	REMARKS
1	3JB-2582U-01	DISC, BRAKE (RIGHT)	2	
2	4NK-2514A-00	RING, WHEEL 1 (LEFT)	1	
3	4NK-2515A-00	RING, WHEEL 2 (RIGHT)	1	
4	90109-083G4	BOLT	12	
5	4NK-2580T-01	CALIPER ASSY (LEFT)	1	
6	1NL-W0057-00	.PISTON ASSY, CALIPER	2	
7	1NL-W0047-00	..CALIPER SEAL KIT	1	
8	4NK-W0045-01	.BRAKE PAD KIT	1	
9	1J3-W0048-00	.BLEED SCREW KIT	1	
10	1KT-25836-00	.COVER, DUST	1	
11	3HE-25924-00	.PIN, PAD	2	
12	3GM-25925-00	.CLIP	2	
13	2GH-25919-00	.SUPPORT, PAD	1	
14	4NK-2580U-01	CALIPER ASSY (RIGHT)	1	
15	1NL-W0057-00	.PISTON ASSY, CALIPER	2	
16	1NL-W0047-00	..CALIPER SEAL KIT	1	
17	4NK-W0045-01	.BRAKE PAD KIT	1	
18	1J3-W0048-00	.BLEED SCREW KIT	1	
19	1KT-25836-00	.COVER, DUST	1	
20	3HE-25924-00	.PIN, PAD	2	
21	3GM-25925-00	.CLIP	2	
22	2GH-25919-00	.SUPPORT, PAD	1	
23	90105-10638	BOLT, WASHER BASED	4	

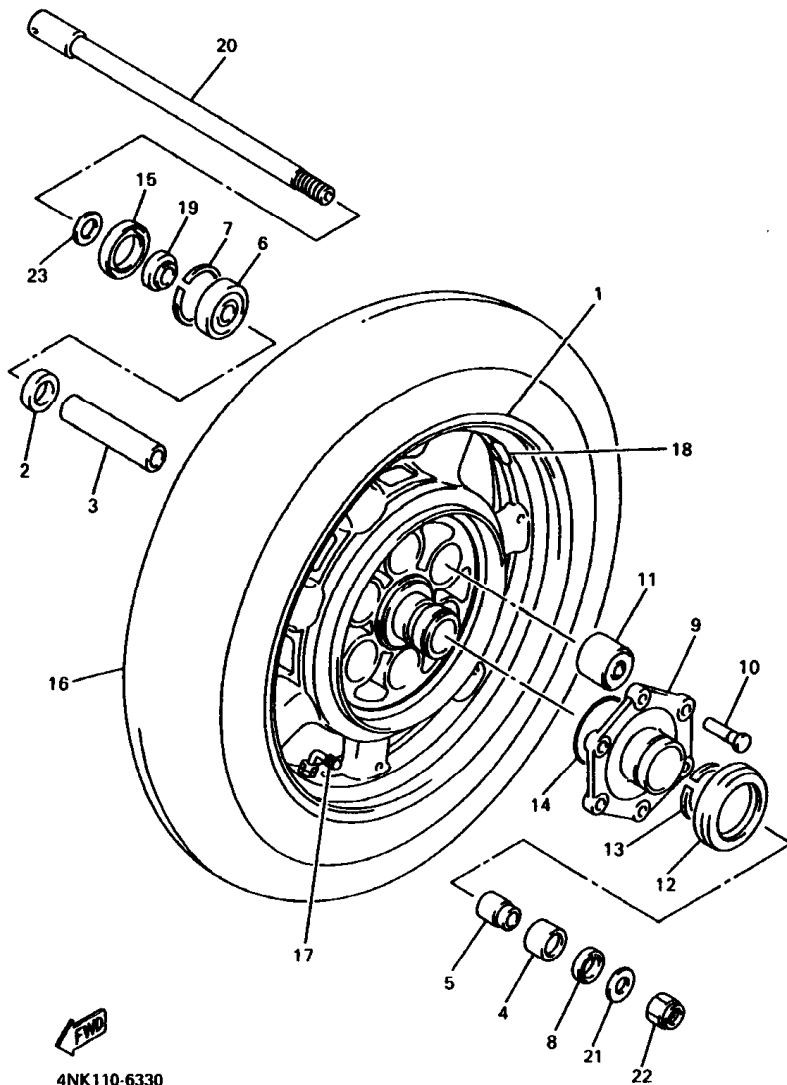

4NK110-6330

FIG. 32 REAR WHEEL

REF. NO.	PART NO.	DESCRIPTION	QTY	REMARKS
1	4NK-25338-00-WG	CAST WHEEL, REAR	1	HTS
2	2H7-25315-00	FLANGE, SPACER	1	
3	90387-2008H	COLLAR	1	
4	93317-32677	BEARING	1	
5	90387-2007J	COLLAR	1	
6	93306-30437	BEARING	1	
7	99009-52500	CIRCLIP	1	
8	93102-25064	OIL SEAL	1	
9	26H-25366-01	CLUTCH, HUB	1	
10	90249-12167	PIN	6	
11	1FK-25384-00	DAMPER	6	
12	1J7-25319-02	SEAL, HUB DUST	1	
13	93440-45022	CIRCLIP	1	
14	93210-68347	O-RING	1	
15	93102-40367	OIL SEAL	1	
16	94115-1513D	TIRE (150/90B15MC 74H D404)	1	DUNLOP
17	93900-00025	VALVE, RIM	1	
18	29L-25398-00	BALANCER, WHEEL (10G)	1	UR
	29L-25398-10	BALANCER, WHEEL (20G)	1	UR
	29L-25398-20	BALANCER, WHEEL (30G)	1	UR
19	90387-200J2	COLLAR	1	
20	4NK-25381-10	AXLE, WHEEL	1	
21	90201-181U5	WASHER, PLATE	1	
22	90185-18167	NUT, SELF-LOCKING	1	
23	92903-20600	WASHER	1	

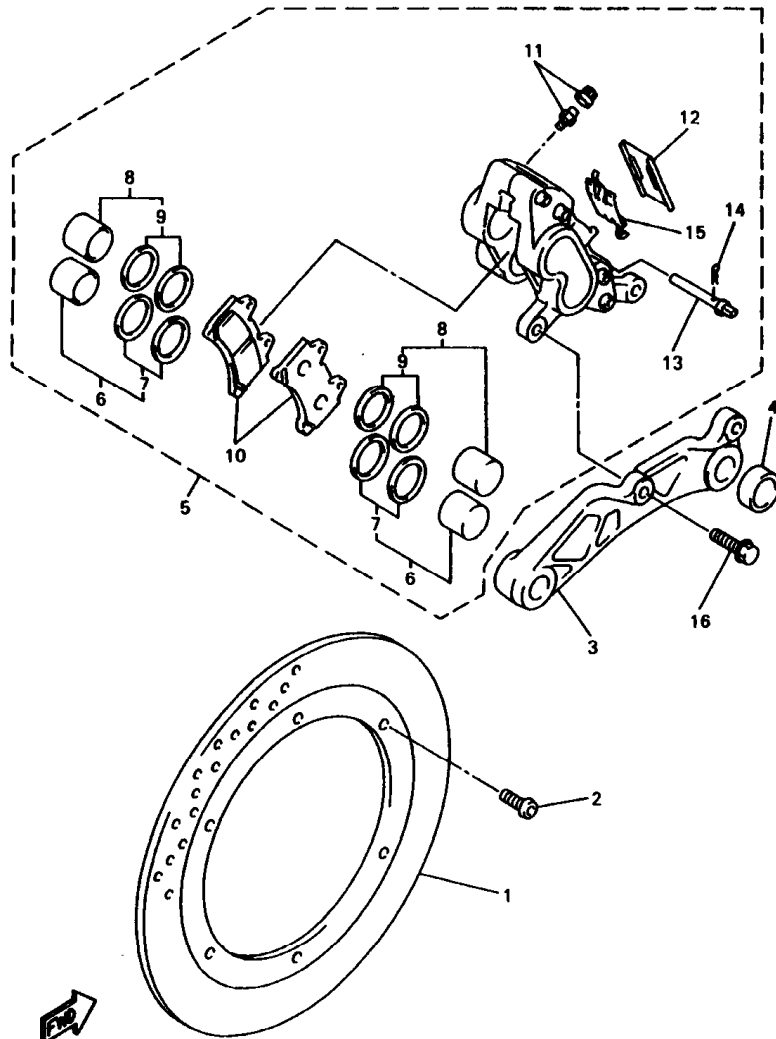

4NK110-6340

FIG. 33 REAR BRAKE CALIPER

REF. NO.	PART NO.	DESCRIPTION	4YP3			REMARKS
1	4NK-2582W-00	DISC, REAR BRAKE 2	1			
2	90109-083G4	BOLT	6			
3	4NK-25819-00	BRACKET, CALIPER	1			
4	4NK-25673-00	DAMPER, BRAKE	1			
5	4NK-2580W-00	CALIPER ASSY, REAR 2	1			
6	1KT-W0057-00	.PISTON ASSY, CALIPER	1			
7	1KT-W0047-00	..CALIPER SEAL KIT	1			
8	4NK-W0057-00	.PISTON ASSY, CALIPER	1			
9	4NK-W0047-00	..CALIPER SEAL KIT	1			
10	4NK-W0046-00	.BRAKE PAD KIT 2	1			
11	1J3-W0048-00	.BLEED SCREW KIT	1			
12	1NL-25836-00	.COVER, DUST	1			
13	3HE-25924-00	.PIN, PAD	2			
14	3GM-25925-00	.CLIP	2			
15	1NL-25919-00	.SUPPORT, PAD	1			
16	90105-10638	BOLT, WASHER BASED	2			

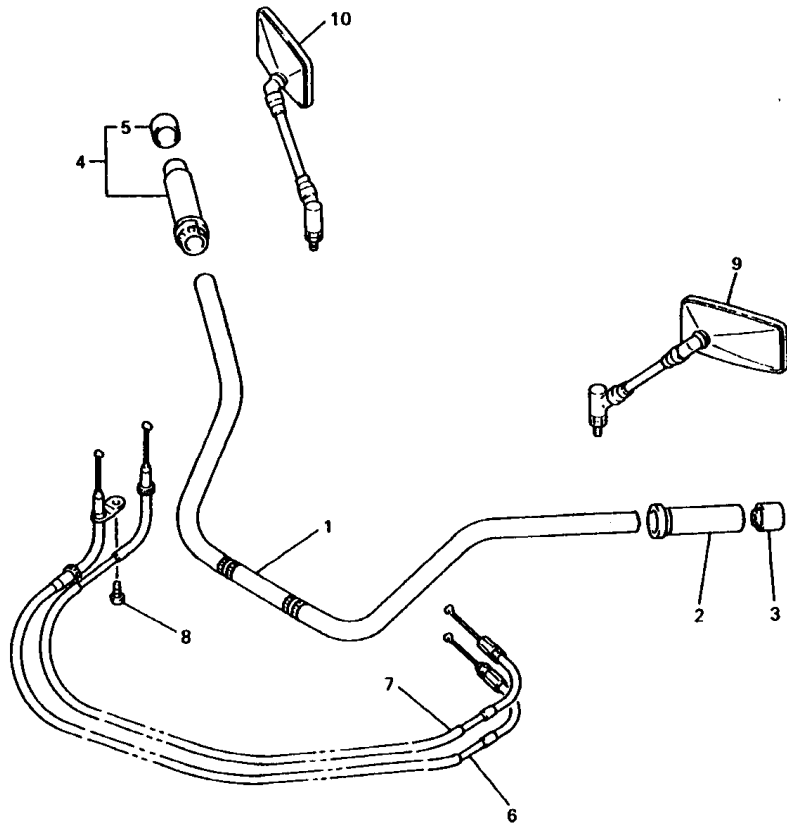

4YP351-7340

FIG. 34 STEERING HANDLE, CABLE

REF. NO.	PART NO.	DESCRIPTION	4YP3				REMARKS
1	5EY-28111-00	HANDLEBAR	1				
2	4NK-28241-00	GRIP (LEFT)	1				
3	4NK-2828J-00	CAP, GRIP	1				
4	4NK-28240-00	GRIP ASSY	1				
5	4NK-2835J-00	.CAP 2	1				
6	4NK-28311-00	CABLE, THROTTLE 1	1				
7	4NK-28312-00	CABLE, THROTTLE 2	1				
8	98507-05008	SCREW, PAN HEAD	1				
9	4H7-28290-A1	REAR VIEW MIRROR ASSY(LEFT)	1				
10	4H7-28290-E1	REAR VIEW MIRROR ASSY(RIGHT)	1				

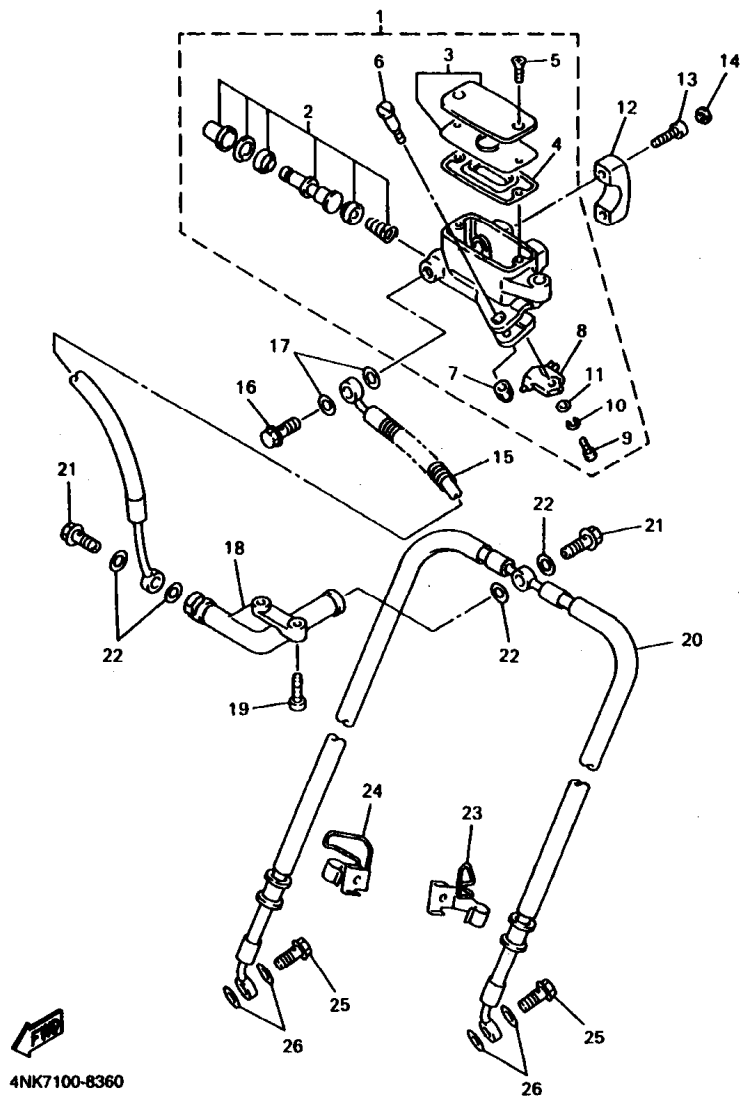
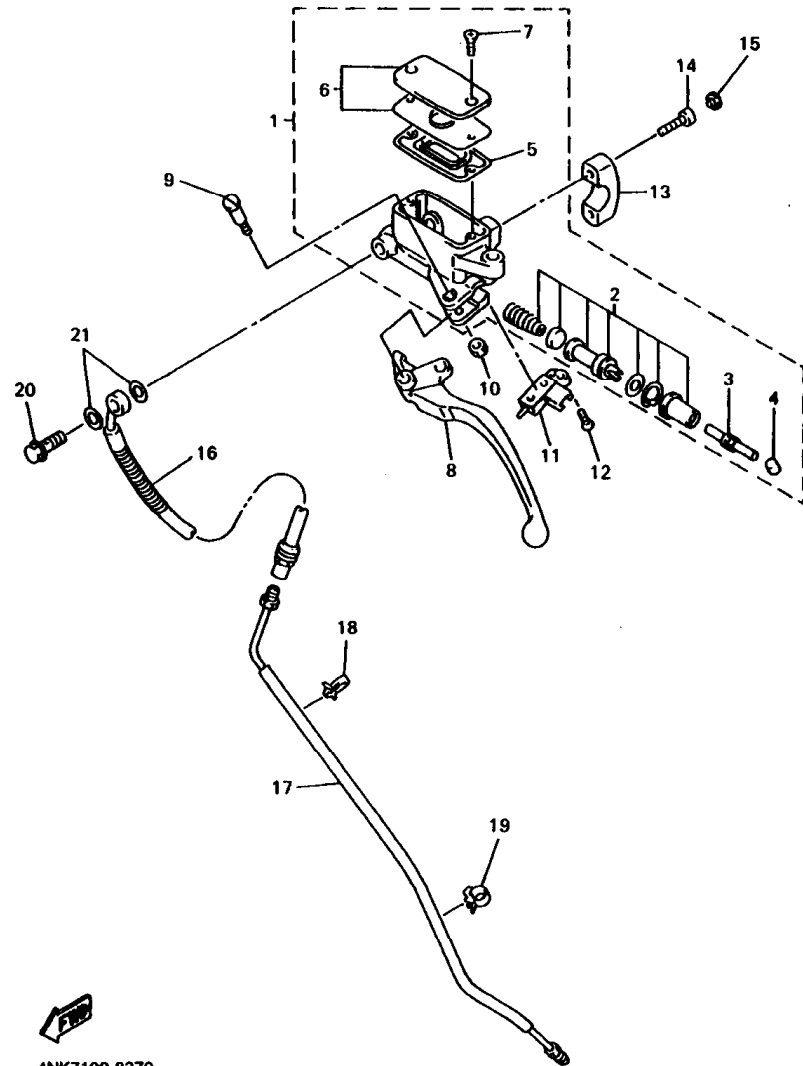

FIG. 35 FRONT MASTER CYLINDER

REF. NO.	PART NO.	DESCRIPTION	QTY	REMARKS
1	4NK-25870-00	MASTER CYLINDER SUB ASSY	1	
2	4K0-W0041-50	.CYLINDER KIT, MASTER	1	
3	4NK-W2585-00	.RESERVOIR CAP SET	1	
4	4NK-25854-00	.DIAPHRAGM, RESERVOIR	1	
5	4NK-2589H-00	.SCREW	2	
6	4NK-2589F-00	.BOLT, LEVER	1	
7	95804-06100	.NUT, U	1	
8	3FV-83980-00	.FRONT STOP SWITCH ASSY	1	
9	98502-04012	.SCREW, PAN HEAD	1	
10	92902-04100	.WASHER, SPRING	1	
11	92902-04800	.WASHER, PLATE	1	
12	4NK-25867-00	BRACKET, MASTER CYLINDER	1	
13	91314-06025	BOLT	2	
14	90338-06182	PLUG	2	
15	4NK-25872-01	HOSE, BRAKE 1	1	
16	90401-10159	BOLT, UNION	1	
17	90201-10118	WASHER, PLATE	2	
18	4NK-25885-00	JOINT	1	
19	91317-06020	BOLT	2	
20	4NK-25873-01	HOSE, BRAKE 2	1	
21	90401-10159	BOLT, UNION	2	
22	90201-10118	WASHER, PLATE	4	
23	4NK-25875-00	HOLDER, BRAKE HOSE 1	1	
24	4NK-25886-00	HOLDER, BRAKE HOSE	1	
25	90401-10159	BOLT, UNION	2	
26	90201-10118	WASHER, PLATE	4	



4NK7100-8370

FIG. 36 FRONT MASTER CYLINDER 2

REF. NO.	PART NO.	DESCRIPTION	4YP3				REMARKS
1	4NK-W2645-00	MASTER CYLINDER SUB ASSY	1				
2	3GM-W0099-00	.CYLINDER KIT, MASTER (CLUTCH)	1				
3	3GM-26464-00	.ROD, PUSH	1				
4	3GM-26455-00	.BUSH	1				
5	4NK-25854-00	.DIAPHRAGM, RESERVOIR	1				
6	4NK-W2585-00	.RESERVOIR CAP SET	1				
7	4NK-2589H-00	.SCREW	2				
8	4XY-83912-00	LEVER 1	1				
9	4NK-83945-00	BOLT, LEVER	1				
10	95604-06100	NUT, U	1				
11	3GM-83980-00	FRONT STOP SWITCH ASSY	1				
12	98706-04016	SCREW, FLAT HEAD	1				
13	4NK-25867-00	BRACKET, MASTER CYLINDER	1				
14	91314-06025	BOLT	2				
15	90338-06162	PLUG	2				
16	4NK-26472-00	HOSE, CLUTCH 1	1				
17	4NK-26471-00	PIPE	1				
18	90464-13133	CLAMP	1				
19	90464-10190	CLAMP	1				
20	90401-10159	BOLT, UNION	1				
21	90201-10118	WASHER, PLATE	2				

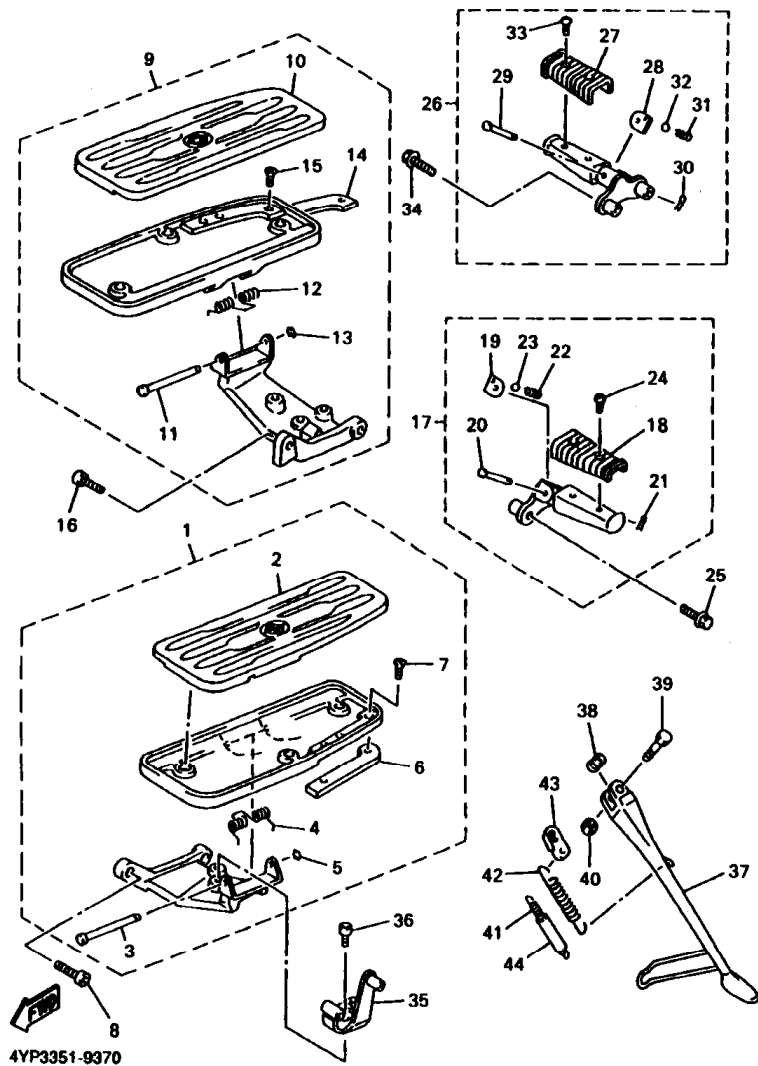

FIG. 37 STAND. FOOTREST

REF. NO.	PART NO.	DESCRIPTION	4YP3				REMARKS
1	4XY-27410-00	FRONT FOOTREST ASSY (LEFT)	1				
2	4XY-27413-00	.COVER, FOOTREST	1				
3	4NK-27427-00	.SHAFT	1				
4	4NK-27428-00	.SPRING, RETURN	1				
5	99001-06600	.CIRCLIP	1				
6	4NK-27498-00	.MOLE 1	1				
7	98780-05010	.SCREW, FLAT HEAD	2				
8	91314-10030	BOLT	2				
9	4XY-27420-00	FRONT FOOTREST ASSY (RIGHT)	1				
10	4XY-27423-00	.COVER, FOOTREST	1				
11	4NK-27427-00	.SHAFT	1				
12	4NK-27426-00	.SPRING, RETURN	1				
13	99001-06600	.CIRCLIP	1				
14	4NK-27497-00	.MOLE 2	1				
15	98780-05010	.SCREW, FLAT HEAD	2				
16	91314-10030	BOLT	2				
17	4NK-27430-00	REAR FOOTREST ASSY 1	1				
18	1NH-27433-00	.COVER, REAR FOOTREST	1				
19	2NT-27437-00	.WASHER, SPECIAL	1				
20	91701-06032	.PIN, CLEVIS	1				
21	91401-16012	.PIN, COTTER	1				
22	90501-12743	.SPRING, COMPRESSION	1				
23	93501-04011	.BALL	1				
24	98517-08012	.SCREW, PAN HEAD	2				
25	95024-08030	BOLT, FLANGE	2				
26	4NK-27440-00	REAR FOOTREST ASSY 2	1				
27	1NH-27433-00	.COVER, REAR FOOTREST	1				

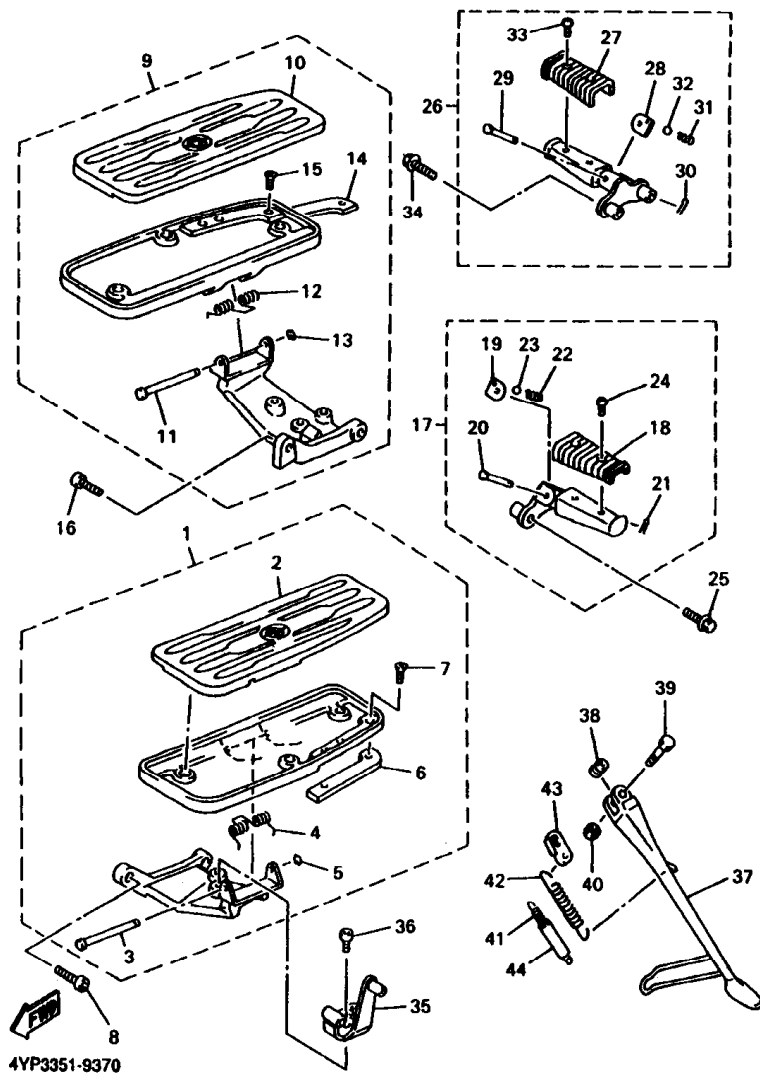

FIG. 37 STAND. FOOTREST

REF. NO.	PART NO.	DESCRIPTION	4YP3			REMARKS
28	2NT-27437-00	.WASHER, SPECIAL	1			
29	91701-06032	.PIN, CLEVIS	1			
30	91401-16012	.PIN, COTTER	1			
31	90501-12743	.SPRING, COMPRESSION	1			
32	93501-04011	.BALL	1			
33	98517-06012	.SCREW, PAN HEAD	2			
34	95024-08030	BOLT, FLANGE	2			
35	4NK-27443-00	BRACKET 3	1			
36	91317-08014	BOLT	2			
37	4NK-27311-01	STAND, SIDE	1			
38	90387-1007K	COLLAR	1			
39	90101-10778	BOLT	1			
40	90185-10037	NUT, SELF-LOCKING	1			
41	90506-18224	SPRING, TENSION	1			
42	90506-28225	SPRING, TENSION	1			
43	2KT-27315-00	LINK, SIDE STAND	1			
44	1TX-27351-00	GUIDE, SIDE STAND	1			

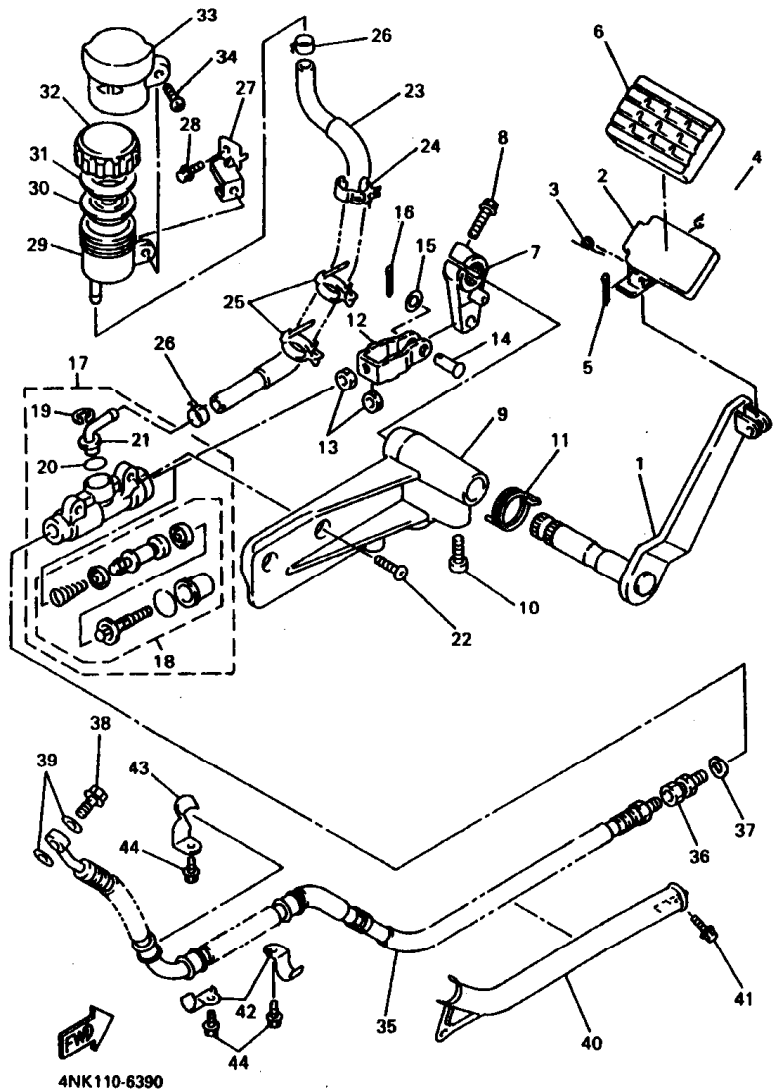
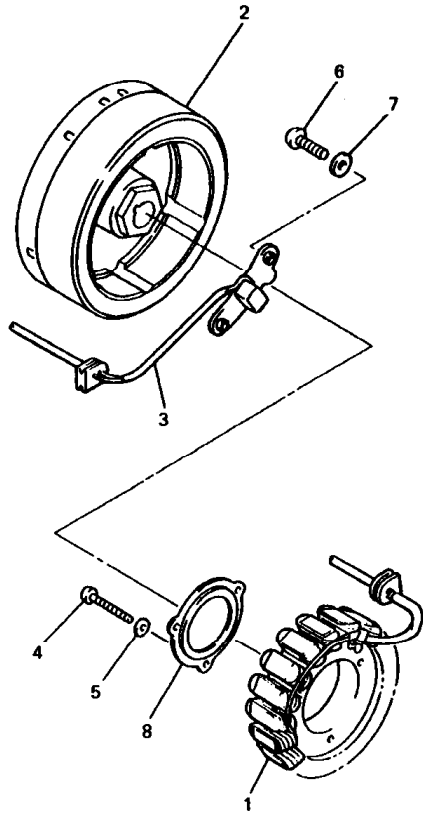

FIG. 38 REAR MASTER CYLINDER

REF. NO.	PART NO.	DESCRIPTION	4YF3				REMARKS
1	4NK-27211-00	PEDAL, BRAKE	1				
2	4NK-27242-00	PEDAL, BRAKE	1				
3	90508-140B8	SPRING, TORSION	1				
4	91701-06022	PIN, CLEVIS	1				
5	91401-20012	PIN, COTTER	1				
6	4NK-27285-00	CAP	1				
7	4NK-27262-00	LEVER	1				
8	95024-06025	BOLT, FLANGE	1				
9	4NK-2741L-00	BRACKET 4	1				
10	91317-08014	BOLT	3				
11	4NK-27318-00	SPRING, SIDE STAND	1				
12	4NK-27222-00	JOINT	1				
13	95307-08700	NUT	2				
14	90240-08013	PIN, CLEVIS	1				
15	90201-08083	WASHER, PLATE	1				
16	91401-16012	PIN, COTTER	1				
17	4NK-2583V-00	RR. MASTER CYLINDER ASSY.	1				
18	1FK-W0042-50	.CYLINDER KIT, MASTER	1				
19	2VN-25866-00	.CIRCLIP	1				
20	93210-15620	.O-RING	1				
21	3LD-2582A-00	.JOINT	1				
22	92014-08020	BOLT, BUTTON HEAD	2				
23	4NK-25895-00	HOSE, RESERVOIR	1				
24	90464-20191	CLAMP	1				
25	90464-20213	CLAMP	2				
26	90467-14057	CLIP	2				
27	4NK-21228-00	BRACKET, RESERVE TANK	1				

FIG. 39 GENERATOR



REF. NO.	PART NO.	DESCRIPTION	4YPS				REMARKS
1	4NK-81410-00	STATOR ASSY	1				
2	4NK-81450-00	ROTOR ASSY	1				
3	4NK-81670-00	PICK-UP ASSY	1				
4	98507-06030	SCREW, PAN HEAD	3				
5	92907-06600	WASHER, PLATE	3				
6	98507-06016	SCREW, PAN HEAD	2				
7	90201-06674	WASHER, PLATE	2				
8	4NK-15113-00	PLATE	1				

4NK110-6420

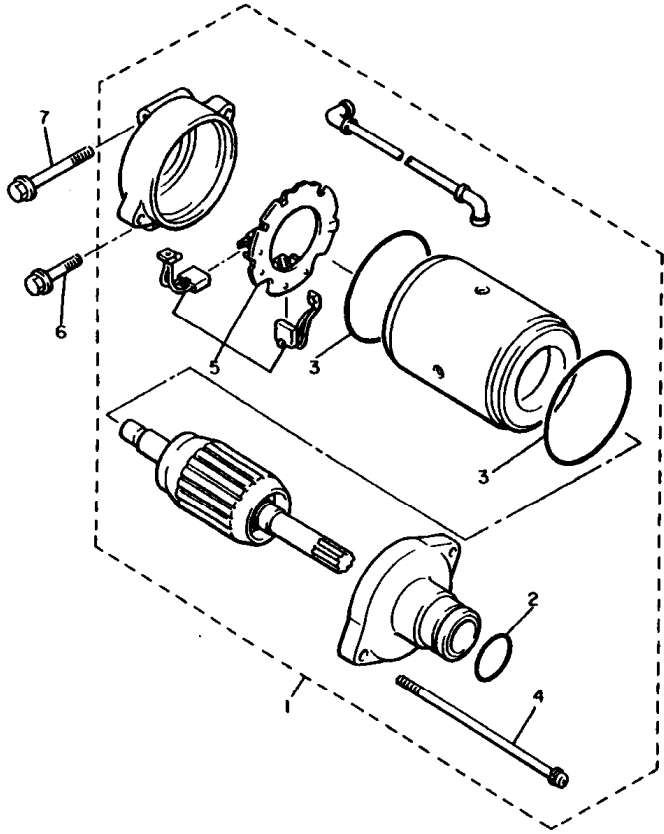

3LR351-0400

FIG. 40 STARTING MOTOR

REF. NO.	PART NO.	DESCRIPTION	4YP3				REMARKS
1	4NK-81800-00	STARTING MOTOR ASSY	1				
2	1FK-81847-00	.O-RING	1				
3	11H-81844-00	.GASKET	2				
4	3AJ-81826-00	.BOLT	2				
5	3AJ-81801-00	.BRUSH SET	1				
6	95827-06025	BOLT, FLANGE	1				
7	95827-06055	BOLT, FLANGE	1				

F9

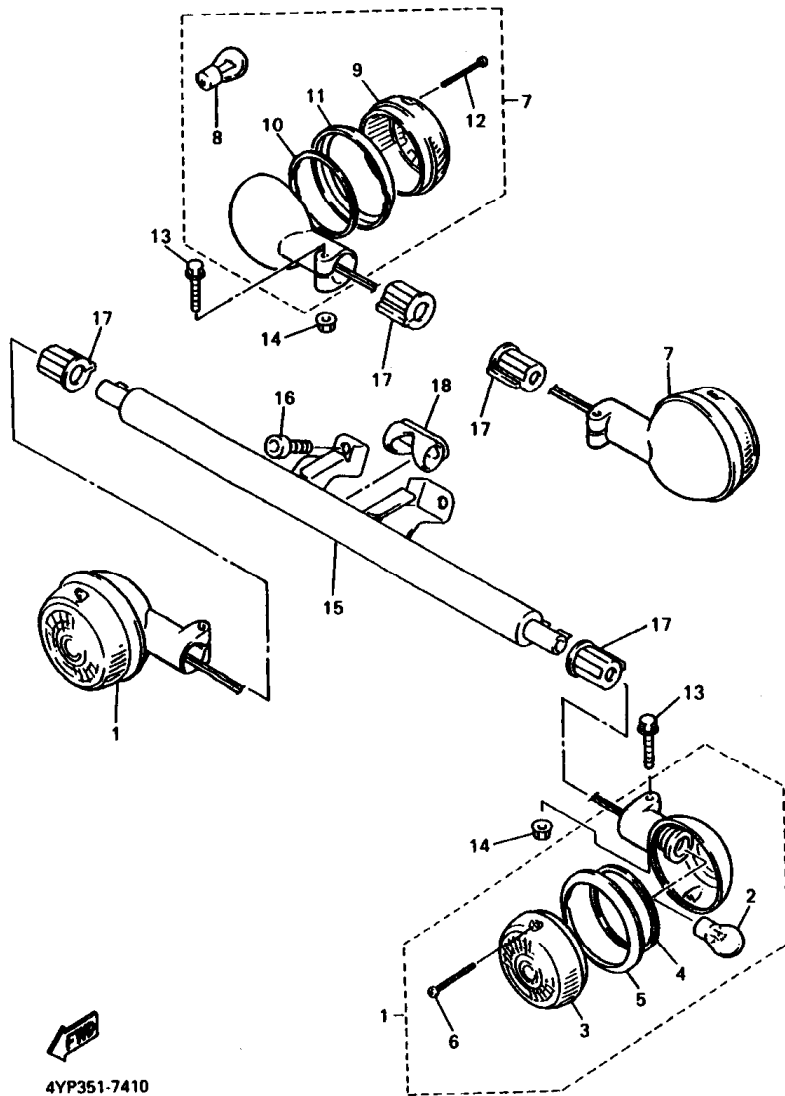

4YP351-7410

FIG. 41 FLASHER LIGHT

REF. NO.	PART NO.	DESCRIPTION	4YP3				REMARKS
1	2EN-83310-00	FRONT FLASHER LIGHT ASSY 1	2				
2	2AE-83311-00	.BULB, FLASHER (12V-21W)	1				
3	42X-83312-00	.LENS, FLASHER	1				
4	42X-83313-00	.GASKET, FLASHER LENS	1				
5	42X-83363-00	.LENS, RIM	1				
6	57M-83358-00	.SCREW, SPECIAL	2				
7	2EN-83330-00	REAR FLASHER LIGHT ASSY 1	2				
8	2AE-83311-00	.BULB, FLASHER (12V-21W)	1				
9	2AE-83312-00	.LENS, FLASHER	1				
10	42X-83313-00	.GASKET, FLASHER LENS	1				
11	42X-83363-00	.LENS, RIM	1				
12	57M-83358-00	.SCREW, SPECIAL	2				
13	95024-06030	BOLT, FLANGE	4				
14	95704-06500	NUT, FLANGE	4				
15	4NK-2317V-00	STAY, 8	1				
16	91314-08016	BOLT	2				
17	4NK-83321-00	DAMPER, FLASHER 1	4				
18	4NK-83345-00	PLUG, BLIND	1				

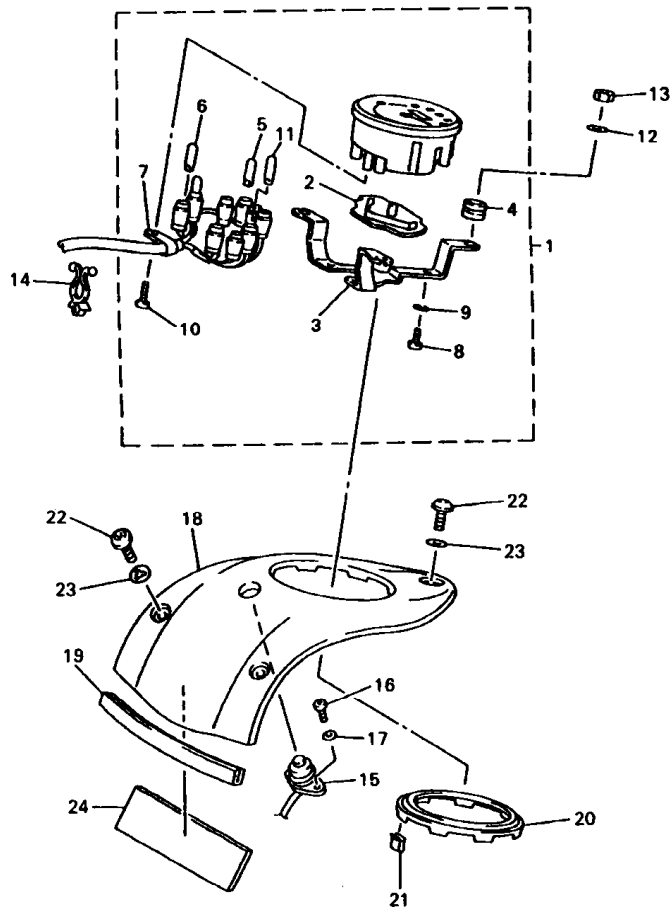

4YP351-7420

FIG. 42 METER

REF. NO.	PART NO.	DESCRIPTION	4YP3		REMARKS
1	4YE-83500-30	SPEEDOMETER ASSY	1		UR
	4YE-83500-20	SPEEDOMETER ASSY	1		UR FOR GBR
2	4NK-83579-00	.COVER, METER 2	1		
3	4NK-83519-00	.BRACKET, METER	1		
4	4NK-83523-00	.DAMPER	3		
5	2GV-83517-00	.BULB (12V-1.7W, T6.5)	6		
6	4NK-83517-00	.BULB (12V-1.4W, T6.5)	2		FOR ILLUMI
7	4NK-8357E-00	.CLAMP	1		
8	98507-04010	.SCREW, PAN HEAD	3		
9	92907-04100	.WASHER, SPRING	3		
10	97707-40012	.SCREW, TAPPING	1		
11	42X-83517-00	.BULB (12V-3W)	1		FOR FUEL
12	90201-05036	WASHER, PLATE	3		
13	95307-05600	NUT	3		
14	90464-13066	CLAMP	1		
15	4NK-8358J-00	SWITCH, METER CONTROL	1		
16	98507-05012	SCREW, PAN HEAD	2		
17	92907-05600	WASHER, PLATE	2		
18	4NK-83559-00	COVER, METER	1		
19	4NK-28345-00	MOLE 1	1		
20	4NK-28346-00	MOLE 2	1		
21	1FK-2171H-00	GUIDE	8		
22	90149-06264	SCREW	3		
23	4U5-2176E-00	PLATE	3		
24	11H-21747-00	DAMPER	1		

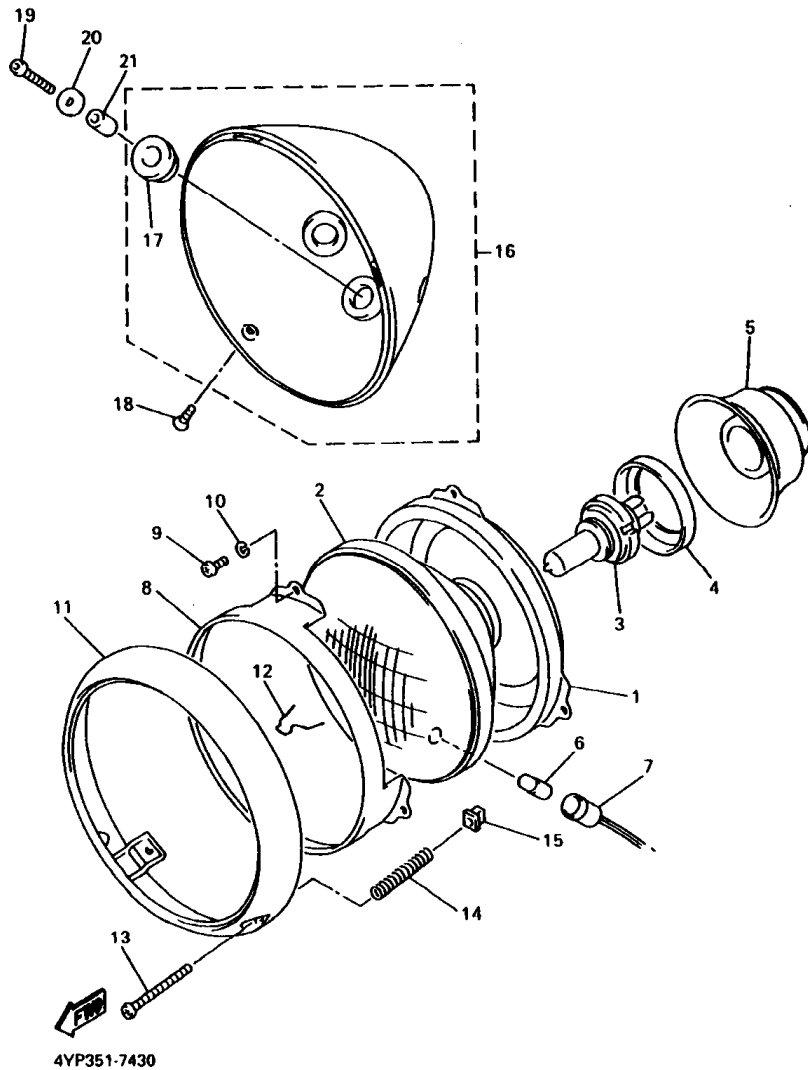
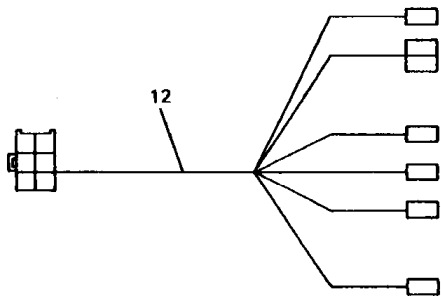
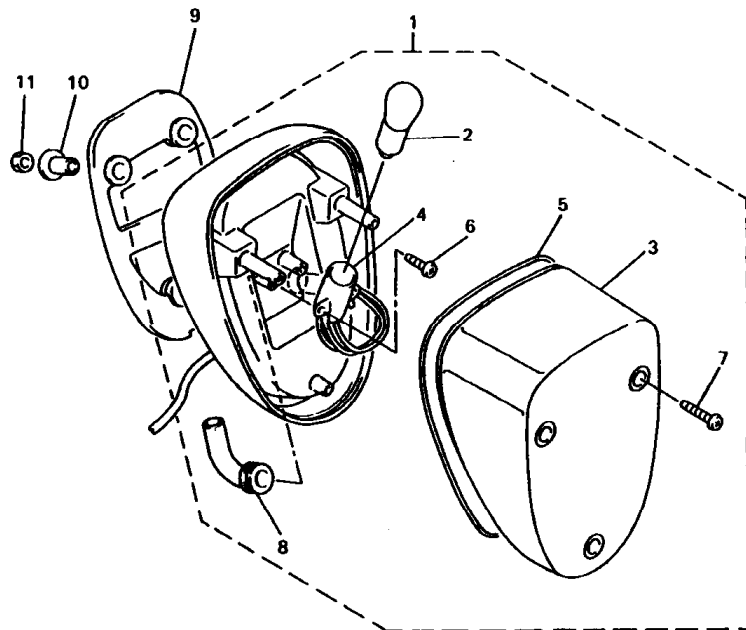

FIG. 43 HEADLIGHT

REF. NO.	PART NO.	DESCRIPTION	4YP3				REMARKS
1	4NK-84394-00	RING, MOUNTING	1				
2	2K3-84321-40	LENS ASSY	1				UR
	2F9-84321-00	LENS ASSY	1				UR FOR GBR
3	2F9-84314-00	BULB (12V-60/55W)	1				(H4)HALOGEN
4	2F9-84375-00	SETTING PLATE, BULB	1				
5	2F9-84397-01	COVER, SOCKET	1				
6	4E2-84347-00	BULB (12V-4W)	1				
7	306-84346-30	SOCKET, PILOT LIGHT	1				
8	2F9-84395-00	RING, RETAINING	1				
9	98502-04008	SCREW, PAN HEAD	3				
10	92902-04100	WASHER, SPRING	3				
11	4NK-84315-00	RIM, HEADLIGHT	1				
12	290-84124-21	SPRING, SET	1				
13	341-84331-60	SCREW, RIM ADJUSTING	2				
14	5G2-84332-60	SPRING, SCREW	2				
15	198-84334-60	NUT, ADJUSTING	2				
16	4NK-84330-00	BODY ASSY	1				
17	42X-84366-00	.DAMPER, HEADLIGHT 1	3				
18	98704-05012	SCREW, FLAT HEAD	2				
19	92017-06025	BOLT, BUTTON HEAD	3				
20	90201-060A3	WASHER, PLATE	3				
21	90387-0610J	COLLAR	3				



4NK7100-8450

FIG. 44 TAILLIGHT

REF. NO.	PART NO.	DESCRIPTION	4YP3	REMARKS
1	5BN-84700-10	TAILLIGHT ASSY	1	
2	31L-84714-00	.BULB, TAILLIGHT (12V-21/5W)	1	
3	4YP-84721-00	.LENS, TAILLIGHT	1	
4	5BN-84735-00	.CORD ASSY	1	
5	4NK-84702-00	.GASKET, TAILLENS	1	
6	97707-40516	.SCREW, TAPPING	2	
7	97780-40525	.SCREW, TAPPING	3	
8	5BN-84154-00	.GROMMET	1	
9	4NK-84527-01	DAMPER	1	
10	90387-063E6	COLLAR	3	
11	95307-06600	NUT	3	
12	4NK-84717-00	CORD, TAILLIGHT	1	

FIG. 45 HANDLE SWITCH. LEVER

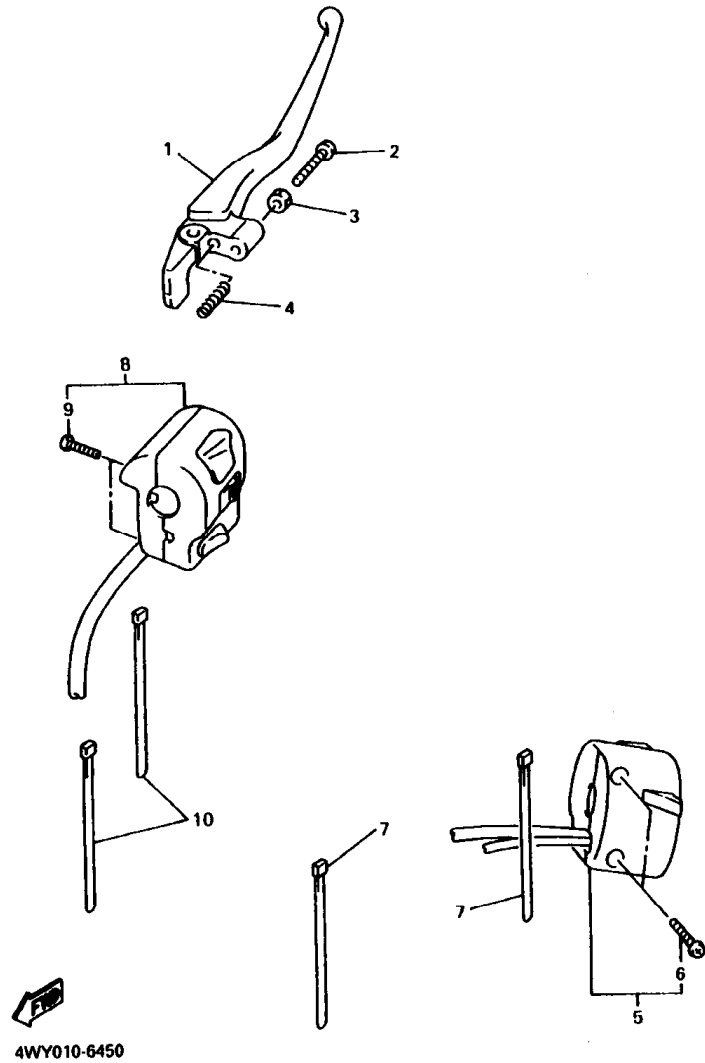

REF. NO.	PART NO.	DESCRIPTION	4YPS				REMARKS
1	5EY-83922-00	LEVER 2	1				
2	90149-08131	SCREW	1				
3	90170-08010	NUT	1				
4	90501-10312	SPRING, COMPRESSION	1				
5	4WY-83972-00	SWITCH, HANDLE 4	1				
6	98504-05025	.SCREW, PAN HEAD	2				
7	1UA-82591-00	BAND	2				
8	4YP-83963-00	SWITCH, HANDLE 3 (RIGHT)	1				
9	98504-05025	.SCREW, PAN HEAD	2				
10	1UA-82591-00	BAND	2				

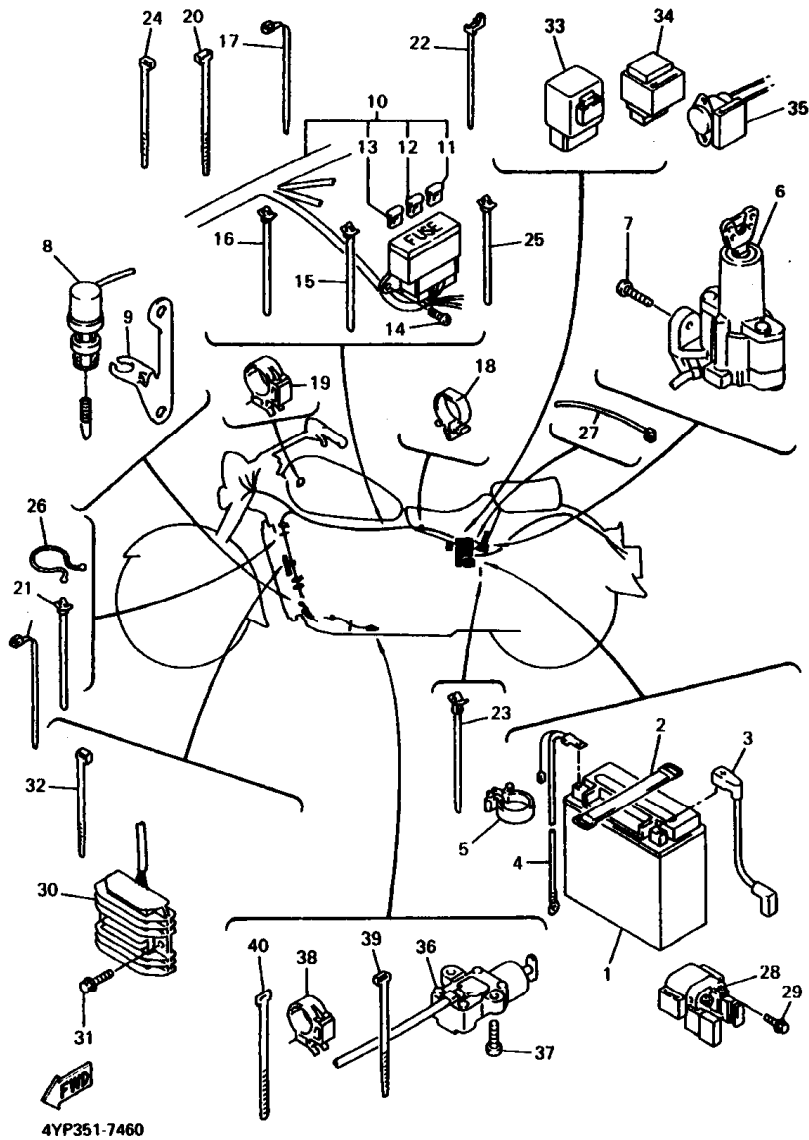

FIG. 46 ELECTRICAL 1

REF. NO.	PART NO.	DESCRIPTION	4YP3				REMARKS
1	4SH-82100-21	BATTERY ASSY (YTX20L-BS)	1				
2	120-82131-00	BAND, BATTERY	1				
3	4NK-82115-00	WIRE, PLUS LEAD	1				
4	4NK-82116-00	WIRE, MINUS LEAD	1				
5	90464-13133	CLAMP	1				
6	4YP-82510-00	MAIN SWITCH ASSY	1				
7	90149-06308	SCREW	2				
8	4NK-82530-00	STOP SWITCH ASSY	1				
9	4NK-82539-00	STAY, STOP SWITCH	1				
10	4YP-82590-10	WIRE HARNESS ASSY	1				
11	42X-82151-00	.FUSE (10A-BL)	3				
12	2GH-82151-00	.FUSE (20A-BL)	3				
13	1NL-82151-00	.FUSE (5A-BL)	2				
14	98907-06012	SCREW, BIND	2				
15	90464-12089	CLAMP	1				
16	90464-12089	CLAMP	1				
17	90464-13073	CLAMP	1				
18	90464-24230	CLAMP	1				
19	90464-10190	CLAMP	1				
20	1UA-82591-00	BAND	1				
21	90464-12089	CLAMP	2				
22	90464-15200	CLAMP	1				
23	90464-10112	CLAMP	2				
24	90464-16061	CLAMP	2				
25	90464-12036	CLAMP	1				
26	90464-30040	CLAMP	2				
27	90464-16061	CLAMP	1				

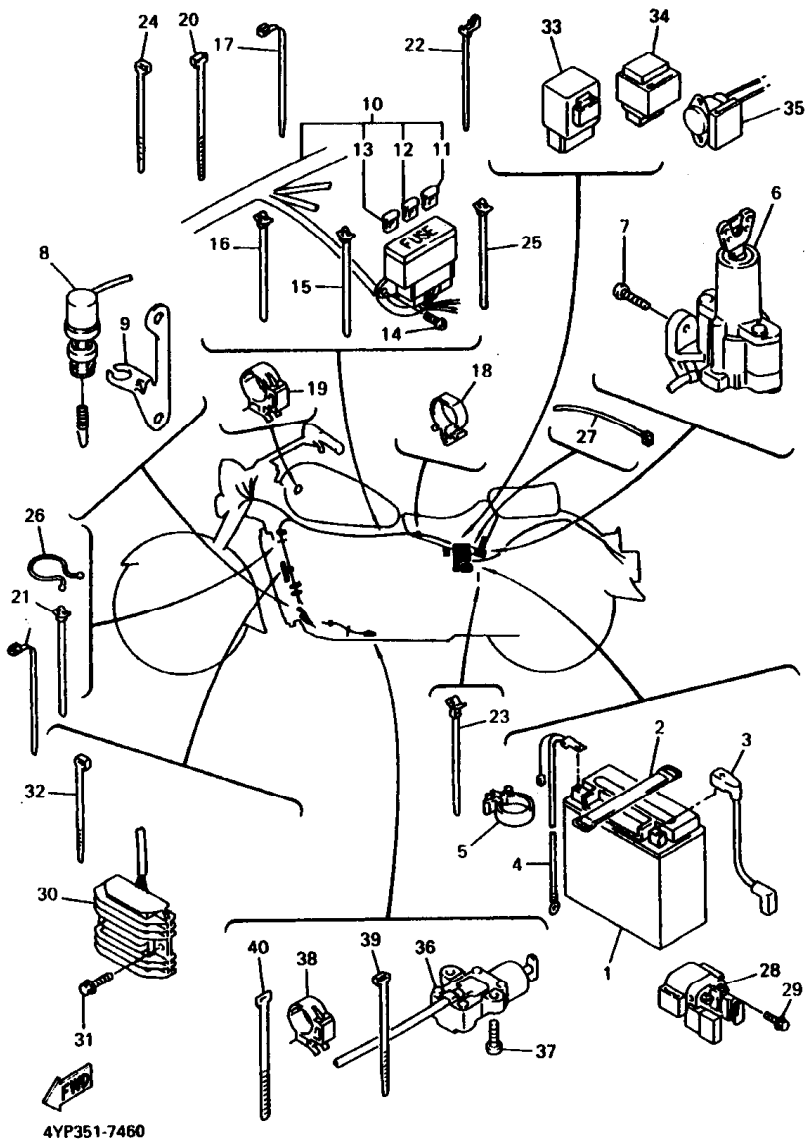

FIG. 46 ELECTRICAL 1

REF. NO.	PART NO.	DESCRIPTION	4YP3	REMARKS
28	4BH-81940-00	STARTER RELAY ASSY	1	
29	95027-06008	BOLT, FLANGE	2	
30	3LS-81960-01	RECTIFIER & REGULATOR ASSY	1	
31	95807-06020	BOLT, FLANGE	2	
32	90464-12045	CLAMP	1	
33	3EN-81950-00	RELAY ASSY	1	FOR SIDE STAND
34	4U8-81950-02	RELAY ASSY	1	
35	3BT-82560-00	THERMO SWITCH ASSY	1	
36	3LD-82566-50	SWITCH, SIDE STAND	1	
37	90157-05079	SCREW, PAN HEAD	2	
38	90464-10190	CLAMP	1	
39	1UA-82581-00	BAND	1	
40	90464-12045	CLAMP	1	
41	90464-13073	CLAMP	1	

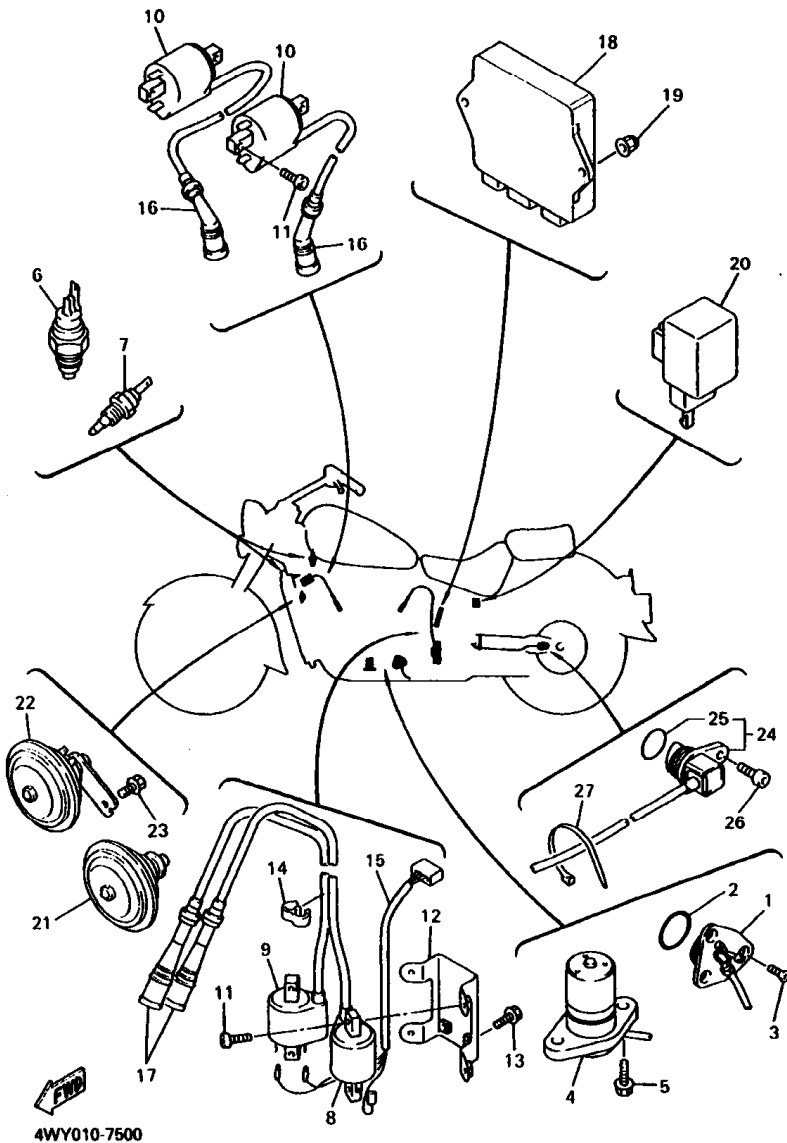

FIG. 47 ELECTRICAL 2

REF. NO.	PART NO.	DESCRIPTION	QTY	REMARKS
1	4WY-82540-00	NEUTRAL SWITCH ASSY	1	
2	93210-29196	O-RING	1	
3	90149-05321	SCREW	3	
4	1FK-85720-00	OIL LEVEL GAUGE ASSY	1	
5	95027-06018	BOLT, FLANGE	2	
6	3LN-82560-01	THERMO SWITCH ASSY	1	
7	3YX-82560-00	THERMO SWITCH ASSY	1	
8	4NK-82310-00	IGNITION COIL ASSY	1	
9	4NK-82310-10	IGNITION COIL ASSY	1	
10	4NK-82320-00	IGNITION COIL ASSY	2	
11	91317-05016	BOLT	8	
12	4NK-82316-00	BRACKET, IGNITION COIL	1	
13	95807-06010	BOLT, FLANGE	2	
14	90464-10075	CLAMP	1	
15	4NK-82509-00	WIRE, SUB LEAD	1	
16	4NK-82370-00	PLUG CAP ASSY	2	
17	1FK-82370-00	PLUG CAP ASSY	2	
18	4WY-82305-00	IGNITOR UNIT ASSY	1	
19	90176-08065	NUT, CROWN	2	
20	3GM-83350-01	FLASHER RELAY ASSY	1	
21	4KG-83371-01	HORN	1	
22	4KG-83371-11	HORN	1	
23	95807-06012	BOLT, FLANGE	2	
24	4NK-83755-00	SENSOR, SPEED	1	
25	4NK-85075-00	O-RING	1	
26	90109-081F0	BOLT	1	
27	90465-13275	CLAMP	1	

NUMERICAL INDEX

PARTNO.	GRID NO.	PARTNO.	GRID NO.	PARTNO.	GRID NO.	PARTNO.	GRID NO.	PARTNO.	GRID NO.	PARTNO.	GRID NO.
4K0-W0041-50	F-2	214-11198-01	B-10	26H-12168-80	B-7	4NK-12551-00	B-13	12R-14191-00	C-6	4NK-14935-00	C-6
1FK-W0042-50	F-6			26H-12169-E0	B-8	1AA-12561-00	B-12	3JD-14197-00	C-6	22V-14940-00	C-6
4NK-W0045-01	E-12			26H-12169-G0	B-8	4NK-12576-00	B-12	4FU-14197-00	C-7	4WY-14940-00	C-5
4NK-W0046-00	E-14	4NK-11400-00	B-5	26H-12169-J0	B-8	4NK-12577-00	B-13	1AE-14227-00	C-5	1HX-14965-00	C-6
1KT-W0047-00	E-14	1FK-11416-01	B-5	26H-12169-L0	B-8	4NK-12578-00	B-12	1HX-14231-23	C-6	22F-14991-00	C-5
1NL-W0047-00	E-12	1FK-11416-11	B-5	26H-12169-NO	B-8	4NK-12579-00	B-12	3G2-14231-19	C-5	4NK-15100-00	C-9
4NK-W0047-00	E-14	1FK-11416-21	B-5	26H-12169-TO	B-8	4NK-12580-00	B-13	1AE-14237-00	C-5	26H-15113-00	C-10
1J3-W0048-00	E-12	1FK-11416-31	B-5	26H-12169-10	B-7	4NK-12589-00	B-13	4HM-14239-00	C-7	4NK-15113-00	F-8
	E-14	1FK-11416-41	B-5	26H-12169-30	B-7	4NK-12590-00	B-13	4NK-14243-00	C-7	26H-15138-00	C-9
1NL-W0048-00	C-15	1FK-11416-51	B-5	26H-12169-50	B-7	4NK-12615-00	B-13	1WG-14251-00	C-6	4NK-15138-00	C-9
1KT-W0057-00	E-14	1FK-11416-61	B-5	26H-12169-70	B-7	4NK-12671-00	B-12	1AE-14261-00	C-5	26H-15148-00	C-9
1NL-W0057-00	E-12	1NL-11610-00	B-5	26H-12169-90	B-8	1FK-13151-00	C-3	4NK-14349-20	C-7	4H7-15189-00	C-9
4NK-W0057-00	E-14	1NL-11610-10	B-5	2WT-12171-00	B-9	26H-13161-00	C-2	4NK-14366-00	C-7	4NK-15191-00	C-11
26H-W0098-00	C-15	1NL-11610-20	B-5	26H-12176-02	B-9	26H-13171-00	C-2	4NK-14396-00	C-6	4NK-15316-00	B-3
3GM-W0099-00	F-3	4NK-11631-00-A0	B-5	26H-12177-01	B-9	26H-13181-03	C-2	4NK-14411-00	C-4	4WY-15316-00	C-11
4NK-W1241-01	B-10	1FK-11633-00	B-5	1NL-12181-00	B-9	26H-13300-02	B-15	4NK-14413-00	B-13	1AA-15326-00	C-9
26H-W1751-01	D-3	4NK-11635-00	B-5	26H-12210-03	B-9	26H-13325-00	B-15	4NK-14414-00	B-13	1AA-15336-00	C-9
4NK-W2211-00-35	D-14	4NK-11636-00	B-5	3JP-12213-01	B-9	26H-13337-01	C-2	31A-14419-00	C-4	2H7-15361-00	C-10
3CK-W2470-00	E-10	26H-11650-00	B-5	26H-12233-00	B-9	26H-13342-00	B-15	4NK-14419-00	C-4	2H7-15363-00	C-11
4NK-W2585-00	F-2	26H-11654-00	B-5	26H-12241-00	B-9	26H-13351-01	B-15	4NK-14421-00	C-4	4NK-15363-00	C-10
	F-3	1FK-11656-00	B-5	26H-12251-00	B-9	26H-13361-00	B-15	31A-14435-00	C-4	26H-15365-00	C-2
4NK-W2645-00	F-3	1FK-11656-10	B-5	26H-12252-00	B-9	3JP-13414-01	C-2	4NK-14437-00	C-4	26H-15366-01	C-2
26H-Y1319-10	C-2	1FK-11656-20	B-5	4WY-1240J-00	B-12	26H-13416-01	C-2	4NK-14451-00	C-4	26H-15373-00	C-10
4NK-Y2150-F0-33	D-10	1FK-11656-30	B-5	4WY-1240K-00	B-12	26H-13417-01	C-2	4NK-14452-00	C-4	26H-15381-00	C-10
4NK-Y2150-90-4X	D-10	1FK-11656-40	B-5	4NK-12405-01	B-12	3FV-13440-00	C-2	4NK-14453-00	C-4	26H-15383-00	C-10
4NK-Y2161-E0-7X	D-10	1FK-11656-50	B-5	1AE-12410-00	B-10	26H-13476-00	C-3	22U-14561-00	C-5	4NK-15411-00	C-11
4NK-Y2161-H0-33	D-10	26H-12111-11	B-7	4NK-12413-00	B-11	353-13552-01	B-10	1FN-14565-00	C-6	4NK-15421-00	C-11
4NK-Y2410-10-01	E-8	4NK-12114-00	B-7	4NK-12417-00	B-10	16G-13569-00	C-4	1HX-14565-00	C-5	4NK-15423-00	C-11
4NK-Y2410-10-02	E-8	26H-12116-00	B-7	4NK-12420-02	B-10	4DN-13575-00	C-4	1UY-14565-00	C-5	4NK-15427-00	C-11
4KG-1111G-00	B-3	26H-12117-00	B-7	26H-12427-00	B-13	4NK-13586-00	C-4	4NK-14610-00	C-8	4NK-15431-00	C-11
4NK-1111H-00	B-3	4G0-12118-00	B-7	26H-12428-00	B-13	4NK-13590-00	C-4	3GD-14613-00	C-8	4NK-15451-00	C-11
4NK-1111M-00	B-3	4KM-12119-00	B-7	1AA-12435-00	B-12	4NK-13782-00	C-3	4NK-14620-00	C-8	3JP-15461-01	C-11
4NK-1111N-00	B-3	26H-12121-11	B-7	11H-12438-00	B-10	4NK-13907-00	E-9	4NK-14630-00	C-8	4NK-15462-00	C-11
4NK-1111P-00	B-3	26H-12153-00-J0	B-7	4NK-1244E-00	B-10	4DN-1410A-01	C-6	4NK-14650-00	C-8	26H-15512-00	C-13
4NK-1111R-00	B-3	26H-12153-00-Y0	B-7	4NK-12449-00	B-10	4NK-14103-00	C-6	4YP-14703-00	C-8	26H-15514-00	C-13
4NK-11110-00	B-2	26H-12168-A0	B-7	1FK-12450-00	B-10	3KW-14105-00	C-5	4YP-14704-00	C-8	26H-15515-00	C-13
4NK-11120-00	B-2	26H-12168-F0	B-7	4NK-12450-00	B-11	3CF-14107-15	C-6	4BH-14714-00	C-8	4NK-15517-00	C-13
26H-11133-10	B-2	26H-12168-H0	B-7	26H-12459-00	B-10	22U-14115-00	C-5	4NK-14714-00	C-8	26H-15521-00	C-13
4NK-11142-00	B-4	26H-12168-K0	B-7	26H-1246A-03	B-13	4NK-14130-00	C-6	4NK-14867-00	C-7	26H-15522-00	C-13
4NK-11152-00	B-3	26H-12168-M0	B-7	26H-1246E-03	B-13	4NK-14130-12	C-6	4WY-1490J-00	C-5	4NK-15590-00	C-13
4NK-11166-00	B-13	26H-12168-R0	B-7	4NK-12461-02	B-12	4NK-14137-00	C-6	4NK-1490L-00	C-6	4NK-16150-01	C-14
1NL-11181-00	B-2	26H-12168-U0	B-7	3XP-12462-00	B-13	35H-14139-00	C-7	4NK-1490L-10	C-6	26H-16154-00	C-14
4NK-11185-00	B-3	26H-12168-W0	B-7	4NK-12465-00	B-12	3DM-14141-30	C-5	4YP-14900-00	C-5	26H-16307-00	C-14
4NK-11186-00	B-3	26H-12168-Y0	B-7	26H-12469-01	B-2	22F-14142-20	C-6	4YP-14901-00	C-5	26H-16321-00	C-14
4NK-11187-00	B-3	26H-12168-00	B-7	4NK-12481-00	B-13	1HX-14147-00	C-5	4YP-14902-00	C-5	26H-16324-00	C-14
4NK-11191-00	B-3	26H-12168-20	B-7	4NK-12482-00	B-14	36Y-14147-00	C-6	4YP-14903-00	C-5	4NK-16334-00	C-14
4NK-11193-00	B-3	26H-12168-40	B-7	4NK-12483-00	B-10	137-14153-00	C-5	4YP-14904-00	C-5	1FK-16335-00	C-14
4NK-11195-00	B-3	26H-12168-60	B-7	4NK-12484-00	B-13	353-14186-00	C-6	3KW-14933-00	C-5	132-16346-00	D-6

NUMERICAL INDEX

PARTNO.	GRID NO.	PARTNO.	GRID NO.	PARTNO.	GRID NO.	PARTNO.	GRID NO.	PARTNO.	GRID NO.	PARTNO.	GRID NO.
1FK-16351-00	C-14	4NK-18185-00	D-5	4NK-21721-00-FW	D-12	4NK-23147-00	E-8	4YE-24240-50	E-8	4NK-2580U-01	E-12
1FK-16352-00	C-14	4NK-18187-01	D-6	4NK-21721-00-33	D-12	4NK-23151-00	E-5	4YP-24240-01	E-8	4NK-2580W-00	E-14
4KG-16356-00	C-14	4NK-18511-00	D-5	4NK-21731-00	D-13			4NK-24311-00	E-9	4NK-2581J-01	F-7
4NK-16357-00	C-14	4NK-18512-00	D-5	1JK-21735-00	D-12	34L-23153-00	E-5	4NK-24312-00	E-9	4NK-25819-00	E-14
1FK-16371-00	C-14	4NK-18513-00	D-5	4NK-21735-00	D-10			4NK-24321-01	E-9	3LD-2582A-00	F-6
4NK-1638A-00	C-15	4NK-18531-00	D-5	4NK-21741-00	D-13	4NK-23157-00	E-5	4KM-24453-00	C-6	3JB-2582U-01	E-12
1FK-16381-11	C-14	26H-18536-00	D-6	11H-21747-00	F-11			3CV-24491-10	D-13	4NK-2582W-00	E-14
1FK-16383-00	C-14	4NK-18540-03	D-5	4U5-2178E-00	F-11	4NK-23163-00	E-8	2GU-24500-01	E-8	4NK-2583V-00	F-6
26H-16384-00	C-14	4UN-18542-00	D-5	4NK-2177G-00	D-12	4NK-23165-00	E-6	4X8-24512-00	E-9	1KT-25836-00	E-12
26H-16385-00	C-14	4UN-18566-00	D-5	26H-21828-00	D-13	4NK-23166-00	E-5	3AJ-24523-00	E-9	1NL-25836-00	E-14
26H-16399-00	C-14	4YP-21110-01-33	D-8	4NK-21871-00	D-13			3AJ-24534-00	E-8	2KF-25852-50	F-7
4NK-17121-01	D-2	4NK-21120-00-33	D-8	4NK-21875-00	D-13	4NK-2317V-00	F-10	1FK-24560-00	E-9	380-25854-01	F-7
4NK-17141-01	D-2	4NK-21150-00-33	D-8	4NK-2214H-00	D-14	4YP-2317W-00	D-10	1FK-24566-00	E-9	4NK-25854-00	F-2
4NK-17151-00	D-2	4NK-2117F-00	D-8	4NK-22141-00	D-14	4NK-23171-00	E-5	4NK-24602-10	E-9		F-3
4NK-17211-01	D-2	4NK-2117G-00	D-9	26H-22143-00	D-14			50W-24705-01	E-10	2GU-25855-00	F-7
4NK-17221-01	D-2	52W-2117G-00	D-12	4NK-2217A-00	D-14	1KT-23181-00	E-8	4NK-2471A-00	E-10	2VN-25866-00	F-6
4NK-17231-01	D-2	4NK-2117M-01	D-8	4NK-2217M-00	D-14	38W-23181-00	E-6	4NL-24710-00	E-10	4NK-25867-00	F-2
4NK-17241-01	D-2	4NK-2117X-00-FW	D-12	26H-22189-00	D-14	4NK-23181-00	E-5	4NL-24711-00	E-10		F-3
4NK-17251-00	D-2	4NK-2117X-00-33	D-12	2H7-2219X-00	D-14			509-24724-00	D-11	4NK-25870-00	F-2
4NK-17411-01	D-2	4XY-21190-00	D-8	4YP-22210-00	E-3	4NK-23181-10	E-6			4NK-25872-01	F-2
4NK-17421-00	D-2	4NK-21228-00	F-6	4YP-23102-00	E-5	4V1-23184-LO	E-5	4NK-24728-00	E-10	4NK-25873-01	F-2
2WE-17524-00	D-3	4NK-21243-00	D-13	4YP-23103-00	E-5			22W-24741-00	E-10	4NK-25875-00	F-2
2WE-17527-00	D-3	4NK-21268-00	D-10	4NK-23110-00	E-5	4NK-23193-00	E-5	4NK-2475H-00	D-11	3XV-25876-00	F-7
3UF-17531-00	D-3	4NK-21269-00	D-10	4YP-23111-00	E-5			4YP-24750-00	E-10	4NK-25876-00	F-7
3UF-17531-10	D-3	4YE-21398-00	D-9			4NK-2331E-00	E-6	4NL-24751-00	E-10	3LC-25885-00	F-7
3UF-17531-20	D-3	4NK-2141V-00	D-8	4NK-23118-01	E-5	4YP-23340-00	E-6	4YP-24754-00	E-10	4NK-25885-00	F-2
3UF-17531-30	D-3	4NK-21445-00	D-8			4NK-23369-00	E-6	4NK-2478E-00	E-10	4NK-25886-00	F-2
3UF-17531-40	D-3	4NK-21446-00	D-9	4NK-23121-00	E-6	1W1-23416-00	E-4	4NK-2478X-00	E-10	4NK-25887-00	F-7
3UF-17531-50	D-3	4X7-2149Y-00	C-4	4NK-23122-00	E-4	26H-23418-01	E-4	4NK-24792-00	E-10	4NK-25888-00	F-7
4X7-17531-00-15	D-3	1KT-21541-00	E-4	4KM-23123-01	E-7	4NK-23435-00	E-4	4NK-24796-00	E-10	4NK-2589F-00	F-2
4X7-17531-00-30	D-3	4NK-21570-50	D-10	4NK-23123-00	E-6	4NK-23437-00	E-4	4NK-2514A-00	E-12	4NK-2589H-00	F-2
4X7-17531-00-60	D-3	4YP-21570-00	D-10	4NK-23125-00	E-5	4NK-23441-00	E-4	4NK-2515A-00	E-12		F-3
1J7-17537-Y0-30	D-15	4NK-21621-00-E9	D-10			4NK-23442-00	E-4	4NK-25168-00-WG	E-11	31A-25894-01	F-7
1J7-17537-Y0-40	D-15	4NK-21621-00-33	D-10	4NK-23126-00	E-5	134-23484-10	D-9	4NK-25181-00	E-11	4NK-25895-00	F-6
1J7-17537-Y0-50	D-15	5A8-21639-00	D-11	3MA-23129-10	E-5	4NK-24129-00	E-8	2H7-25315-00	E-13	1NL-25919-00	E-14
26H-17551-00	D-3	51Y-21639-00	D-12			1LJ-2414J-00	D-8	1J7-25319-02	E-13	2GH-25919-00	E-12
26H-17556-00	D-3	4NK-2164F-00	D-10	4NK-23135-00	E-5	4NK-24161-00	E-8	4NK-25338-00-WG	E-13	3HE-25924-00	E-12
2H7-17571-01	D-3	4NK-2164G-00	D-10			4NK-24162-00	E-8	1FK-25384-00	E-13		E-14
56W-17590-00	E-2	4YP-21641-00	D-11	4NK-23136-00	E-5	25H-24180-00	E-9	26H-25386-01	E-13	3GM-25925-00	E-12
4NK-18101-01	D-6	4NK-21649-00	D-10	4NK-23141-01	E-5	2GH-24181-00	E-8	4NK-25381-10	E-13		E-14
4NK-18110-00	D-6	4NK-2165A-50	D-10	4NK-23142-00	E-5	4NK-24181-00	E-8	29L-25398-00	E-11	5EY-26111-00	E-15
4NK-18113-00	D-6	4YP-2165A-00	D-10	4NK-23144-00	E-5	4NK-24182-00	E-8			4NK-26240-00	E-15
4NK-18115-00	D-6	4NK-2171A-00	E-8			2GH-24183-00	E-8	29L-25398-10	E-11	4NK-26241-00	E-15
26H-18140-01	D-6	4NK-2171E-00-33	D-8	4NK-23145-00	E-5	4NK-24183-00	E-8			4NK-2626J-00	E-15
4NK-18141-00	D-5	1FK-2171H-00	F-11			2GH-24186-00	E-8	29L-25398-20	E-11	4H7-26290-A1	E-15
4NK-18150-02	D-6	4NK-2171X-00-33	D-8	4NK-23146-00	E-5	4NK-24186-00	E-8			4H7-26290-E1	E-15
4NK-18151-01	D-7	4NK-21711-00-FW	D-12			31A-24188-01	E-8	4NK-25673-00	E-14	4NK-26311-00	E-15
2H9-18154-00	D-6	4NK-21711-00-33	D-12	4NK-23147-00	E-5	4NK-24191-00	E-8	4NK-2580T-01	E-12	4NK-26312-00	E-15



NUMERICAL INDEX

PARTNO.	GRID NO.	PARTNO.	GRID NO.	PARTNO.	GRID NO.	PARTNO.	GRID NO.	PARTNO.	GRID NO.	PARTNO.	GRID NO.
4NK-2635J-00	E-15	4YE-46153-00	D-15	4NK-82594-00	D-9	2F9-84375-00	F-12	90118-10411	C-9	90201-06589	D-7
3GM-26455-00	F-3	1FK-46154-00	E-2	2EN-83310-00	F-10	4NK-84394-00	F-12	90118-10429	C-9	90201-06674	F-8
3GM-26464-00	F-3	1FK-46156-00	E-2	2AE-83311-00	F-10	2F9-84395-00	F-12	90118-10593	D-15	90201-06765	E-10
4NK-26471-00	F-3	1FK-46157-00-15	E-2	2AE-83312-00	F-10	2F9-84397-01	F-12	90119-05071	E-9	90201-08083	F-6
4NK-26472-00	F-3	1FK-46157-00-20	E-2	42X-83312-00	F-10	4NK-84527-01	F-13	90119-06044	D-13	90201-085R5	C-6
118-27114-00	C-8	4NK-46172-00	E-2	42X-83313-00	F-10	2AL-84553-00	D-14	90119-06096	D-13	90201-08676	D-4
4NK-27211-00	F-6	4X7-46180-00	E-2	4NK-83321-00	F-10	5BN-84700-10	F-13	90149-05321	D-5	90201-10118	C-15
4NK-27222-00	F-6	4NK-81410-00	F-8	2EN-83330-00	F-10	4NK-84702-00	F-13		G-3		F-2
4NK-27242-00	F-6	4NK-81450-00	F-8	4NK-83345-00	D-10	31L-84714-00	F-13	90149-08011	E-9		F-3
4NK-27262-00	F-6	4WY-81517-00	C-7		F-10	4NK-84717-00	F-13	90149-08131	F-14		F-7
4NK-27285-00	F-6	4NK-81670-00	F-8	3GM-83350-01	G-3	4YP-84721-00	F-13	90149-08229	D-7	90201-10128	C-2
4NK-27311-01	F-5	4NK-81800-00	F-9	57M-83358-00	F-10	5BN-84735-00	F-13	90149-08264	F-11	90201-102G9	B-3
2KT-27315-00	F-5	3AJ-81801-00	F-9	42X-83363-00	F-10	4NK-85075-00	G-3	90149-08280	D-6	90201-105A2	D-9
4NK-27316-00	F-6	3AJ-81826-00	F-9	4KG-83371-01	G-3	3Y6-85130-02	D-11	90149-08298	D-12	90201-11597	C-10
1TX-27351-00	F-5	11H-81844-00	F-9	4KG-83371-11	G-3	1FK-85720-00	G-3	90149-08308	F-15	90201-121H0	B-6
4NK-27411-00	F-6	1FK-81847-00	F-9	4YE-83500-20	F-11	4NK-85752-01	E-9	90149-08152	C-10	90201-122F8	E-4
4XY-27410-00	F-4	4BH-81940-00	G-2	4YE-83500-30	F-11	5G3-85753-00	E-9	90151-06013	D-5	90201-126A7	D-14
4XY-27413-00	F-4	3EN-81950-00	G-2	2GV-83517-00	F-11	4NK-85885-00	C-7	90151-06041	C-10		E-3
4XY-27420-00	F-4	4U8-81950-02	G-2	4NK-83517-00	F-11	90101-10778	F-5		D-6	90201-12688	D-6
4XY-27423-00	F-4	3LS-81980-01	G-2	42X-83517-00	F-11	90101-12498	E-3	90157-05079	G-2	90201-127E1	D-6
36Y-27424-00	D-9	4SH-82100-21	F-15	4NK-83519-00	F-11	90101-12749	D-14	90159-06033	D-13	90201-12790	C-10
4NK-27426-00	F-4	4DH-82103-00	C-6	4NK-83523-00	F-11		E-3	90159-06084	D-12	90201-166R5	D-15
4NK-27427-00	F-4	4NK-82115-00	F-15	4NK-83559-00	F-11	90105-06153	B-2	90170-06010	F-14	90201-166R6	D-3
4NK-27430-00	F-4	4NK-82116-00	F-15	4NK-8357E-00	F-11	90105-07342	B-9	90170-06228	D-6	90201-181U5	E-13
1NH-27433-00	F-4	120-82131-00	F-15	4NK-83579-00	F-11	90105-08310	D-9	90170-20323	C-14	90201-220T0	E-4
2NT-27437-00	F-4	1NL-82151-00	F-15	4NK-8358J-00	F-11	90105-10248	C-9	90178-05054	E-9	90201-231A2	E-2
	F-5	2GH-82151-00	F-15	4NK-83755-00	G-3	90105-10249	C-9	90178-06085	G-3	90201-232K5	D-2
4NK-27440-00	F-4	42X-82151-00	F-15	4EB-83790-00	C-6	90105-10638	E-12	90178-10075	D-8	90201-252K4	D-3
4NK-27443-00	F-5	4WY-82305-00	G-3	4XY-83912-00	F-3		E-14		E-2	90201-25634	D-3
4NK-27496-00	F-4	4NK-82310-00	G-3	5EY-83922-00	F-14	90105-10788	D-8	90178-12052	E-4	90201-350F3	C-13
4NK-27497-00	F-4	4NK-82310-10	G-3	4NK-83945-00	F-3	90105-12252	D-8	90178-22081	E-4	90202-05193	E-9
4NK-28100-00	D-9	4NK-82316-00	G-3	4YP-83963-00	F-14	90105-12584	B-5	90179-06327	B-5	90202-06170	D-10
4NK-28173-00	D-9	4NK-82320-00	G-3	4WY-83972-00	F-14	90109-063F8	D-6	90179-08442	C-8	90202-06172	D-12
4NK-28345-00	F-11	1FK-82370-00	G-3	3FV-83980-00	F-2	90109-066F0	B-3	90179-10414	B-3	90202-26142	E-4
4NK-28346-00	F-11	4NK-82370-00	G-3	3GM-83980-00	F-3	90109-081F0	G-3	90179-16661	D-15	90208-04029	D-9
4YE-46101-00	D-15	4NK-82509-00	G-3	290-84124-21	F-12	90109-083G4	E-12	90179-16662	D-3	90209-06174	D-8
2H7-46102-00	D-15	4YP-82510-00	F-15	5BN-84154-00	F-13		E-14	90179-25033	E-4	90209-12341	D-8
1J7-46117-Y0-30	E-2	4NK-82530-00	F-15	2F9-84314-00	F-12	90109-08441	D-6	90179-44328	D-3	90209-21281	D-3
1J7-46117-Y0-40	E-2	4NK-82539-00	F-15	4NK-84315-00	F-12	90109-103G0	C-9	90183-06053	D-10	90209-25198	D-2
1J7-46117-Y0-50	E-2	4WY-82540-00	G-3	2F9-84321-00	F-12	90109-104E4	D-14	90185-10037	F-5	90209-27192	D-2
22U-46118-00-12	D-15	3BT-82560-00	G-2	2K3-84321-40	F-12	90110-05201	E-10	90185-12119	D-14	90209-32231	D-2
22U-46118-00-14	D-15	3LN-82560-01	G-3	4NK-84330-00	F-12	90110-06035	C-15		E-3	90215-08115	D-6
22U-46118-00-16	D-15	3YX-82560-00	G-3	341-84331-60	F-12	90110-06200	D-10	90185-18167	E-13	90215-25218	C-14
22U-46118-00-18	D-15	3LD-82568-50	G-2	5G2-84332-60	F-12	90110-06243	C-15	90201-05036	F-11	90240-08013	F-6
22U-46118-00-20	D-15	4YP-82590-10	F-15	198-84334-60	F-12	90110-06193	C-13	90201-060A3	F-12	90249-12167	E-13
4H7-46123-01	D-15	1UA-82591-00	F-14	306-84346-30	F-12	90110-10161	D-8	90201-06043	D-10	90254-03006	B-2
4H7-46125-00	D-15		F-15	4E2-84347-00	F-12	90110-10181	D-8	90201-06070	D-6	90269-04003	D-9
1FK-46152-01	D-15		G-2	42X-84368-00	F-12	90118-08427	D-15	90201-08071	E-8	90269-05049	D-8

NUMERICAL INDEX

PART NO.	GRID NO.	PART NO.	GRID NO.	PART NO.	GRID NO.	PART NO.	GRID NO.	PART NO.	GRID NO.	PART NO.	GRID NO.
90269-06046	E-10	90430-08119	C-3	90467-11019	D-13	91314-06080	B-10	92907-06100	B-12	93306-20645	D-2
90269-07076	D-8	90445-05278	B-10	90467-11090	B-13	91314-08016	F-10		E-10	93306-20901	D-3
	E-8	90445-09117	D-13	90467-11108	C-4	91314-08025	D-10	92907-06600	B-12	93306-30430	D-2
90280-05029	B-5	90445-097F7	B-12	90467-12053	E-9		E-4		F-8	93306-30437	E-13
90331-15039	D-2	90445-112K5	E-9	90467-13123	C-4	91314-10030	F-4	92907-06700	E-2	93306-30533	D-15
90338-06162	F-2	90445-115J9	C-4	90467-14015	B-13	91317-05010	C-3	93101-10090	B-10	93306-36401	D-2
	F-3	90445-124J5	C-4	90467-14057	F-6	91317-05016	G-3	93101-30084	D-15	93306-90602	D-5
90338-08163	E-4	90446-07114	D-11	90467-23109	B-12	91317-06010	B-13	93101-35085	D-3	93311-21044	E-2
90338-09161	E-4	90450-28014	B-12		B-13		D-9	93101-38098	D-15	93311-43729	D-15
90338-10150	B-3		B-13	90480-13163	D-13	91317-06012	B-14	93102-14209	D-6	93316-01403	D-15
90338-11152	C-9	90450-32051	B-12	90480-13398	D-12	91317-06016	B-10	93102-25064	E-13	93317-32677	E-13
90338-20113	D-14	90450-38040	B-13	90480-13567	D-12	91317-06020	B-11	93102-28021	E-11	93317-41781	D-14
90340-14132	B-10	90460-54085	C-4		D-13		B-9	93102-40367	E-13		E-3
	C-2	90461-06087	C-6	90480-15061	D-10		C-4	93102-70167	E-2	93317-42060	D-14
	E-2	90461-15100	C-3	90480-16284	B-12		F-2	93106-28023	D-14	93332-00001	E-4
90340-14135	E-2		E-9		E-4	91317-06025	B-15	93106-23007	E-2	93332-00008	E-4
90340-14139	C-11	90462-10226	C-3	90480-18276	B-10	91317-06030	C-2	93109-09061	C-14	93332-00024	D-3
90340-18101	B-2	90464-10075	C-7	90480-18354	E-8	91317-08014	F-5	93210-06632	C-14	93332-00028	D-3
90387-06027	E-8		G-3	90480-19283	B-12		F-6	93210-06667	C-10	93332-00050	D-14
90387-0609L	B-12	90464-10112	F-15	90480-20384	D-12	91317-10040	D-9		C-2	93332-00051	D-14
90387-0610J	F-12	90464-10190	F-15	90501-06022	D-5	91401-18012	F-4	93210-13361	C-2	93410-22039	E-2
90387-062L2	D-13		F-3	90501-10312	F-14		F-5	93210-14389	C-11	93410-23058	D-2
90387-06299	E-8		G-2	90501-12743	F-4		F-6	93210-14579	C-2		E-2
90387-063E6	F-13	90464-12036	F-15		F-5	91401-20012	F-6	93210-14637	C-2	93440-12117	B-2
90387-06805	E-4	90464-12045	G-2	90501-16491	E-2	91701-06022	F-6	93210-15620	F-6	93440-20068	E-2
90387-067N5	D-12	90464-12089	F-15	90501-75638	D-3	91701-06032	F-4	93210-16629	B-2	93440-28062	D-2
90387-1007K	F-5	90464-13068	F-11	90506-06227	D-6		F-5	93210-18322	B-2	93440-30077	D-2
90387-104L8	D-9	90464-13073	C-10	90506-18224	F-5	91806-16023	B-2		C-14	93440-34025	D-2
90387-122J6	D-14		E-9	90506-26225	F-5	92014-06012	D-10	93210-18417	B-13	93440-45022	E-13
90387-126Y1	D-14		F-15	90507-14084	D-6	92014-06014	B-3		B-14	93440-52118	D-2
	E-3		G-2	90508-140B8	F-6		C-11	93210-21631	B-2	93450-19095	B-5
90387-200J2	E-13	90464-13103	E-9	90508-32588	D-6	92014-06016	F-7	93210-22382	C-9	93501-04011	F-4
90387-2007J	E-13	90464-13133	F-15	90560-30234	D-5	92014-06030	B-3	93210-23787	B-10		F-5
90387-2008H	E-13		F-3	91314-06014	B-10	92014-06020	F-6	93210-27370	C-10	93511-32017	C-14
90387-204H5	D-14	90464-15200	F-15	91314-06016	B-13	92014-06025	D-10		C-11	93603-07073	C-14
90387-2200T	E-11	90464-18061	F-15	91314-06020	B-3	92017-06010	B-12	93210-29196	G-3	93603-10049	D-5
90387-2206J	E-11	90464-20191	D-9	91314-06025	B-10	92017-06025	F-12	93210-45150	C-11	93603-14026	B-10
90401-06038	C-2		F-6		C-11	92017-06035	E-8	93210-49046	B-11	93604-12037	D-5
90401-06093	C-3	90464-20213	F-6		C-12	92017-06020	C-8	93210-60426	D-15	93604-16092	D-5
90401-10108	C-2	90464-24230	F-15		F-2	92017-06025	C-8	93210-62446	D-9	93900-00025	E-13
90401-10159	F-2	90464-30040	F-15		F-3	92902-04100	F-12	93210-68347	E-13	93900-00030	E-11
	F-3	90465-08193	C-3	91314-06030	B-10		F-2	93210-71360	D-3	94115-1513D	E-13
	F-7	90465-08233	C-10		E-4	92902-04600	F-2	93211-113A8	B-10	94115-1611R	E-11
90401-10168	C-15	90465-13275	G-3	91314-06035	C-11	92903-10100	E-2	93211-54898	D-15	94590-44118	B-9
90401-20145	C-2	90467-08003	B-12		C-12	92903-20600	E-13	93306-00006	B-10	94600-02001	B-9
90430-06014	C-11	90467-09006	D-13	91314-06040	B-13	92904-06600	D-14	93306-00304	C-14	94701-00262	B-2
90430-06186	C-9	90467-10039	C-4	91314-06045	C-11	92907-04100	F-11	93306-00420	E-11	94701-00379	B-2
90430-08119	C-2	90467-10041	E-9	91314-06060	C-11	92907-05600	F-11	93306-20555	D-2	95024-06010	D-11

NUMERICAL INDEX

PARTNO.	GRID NO.	PARTNO.	GRID NO.	PARTNO.	GRID NO.	PARTNO.	GRID NO.	PARTNO.	GRID NO.
95024-08012	F- 7	95817-08085	C- 9	98907-05010	D- 13				
95024-08025	F- 6	95817-08095	C- 9	98907-05012	E- 9				
95024-08030	F- 10	95817-10050	D- 15	98907-08012	F- 15				
95024-08012	E- 10	95827-08012	B- 13	99001-08800	F- 4				
95024-08030	F- 4	95827-08014	E- 8	99001-10800	D- 6				
	F- 5	95827-08025	F- 9	99009-10400	B- 10				
95027-08008	G- 2	95827-08055	F- 9	99009-11400	B- 15				
95027-08010	F- 7	95827-08030	D- 4	99009-12400	B- 15				
95027-08012	D- 11	95827-10035	D- 8	99009-52500	E- 13				
	E- 10	95827-10070	D- 8	99237-00080	D- 10				
95027-08018	F- 7	97007-05018	D- 8	99530-08018	C- 2				
	G- 3	97007-08012	B- 12	99530-10114	B- 10				
95027-08020	C- 8	97007-08020	D- 12		B- 15				
95304-08700	D- 6		E- 10		C- 11				
95307-05800	F- 11	97007-08025	C- 14		C- 9				
95307-08800	F- 13	97007-08040	B- 12	99530-14016	B- 3				
95307-08700	F- 6	97024-08020	D- 8						
95317-08800	D- 15	97024-08025	D- 14						
95317-10800	D- 9	97027-08020	D- 7						
95604-08100	F- 2	97080-08008	C- 8						
	F- 3	97707-40012	F- 11						
95807-10200	D- 14	97707-40518	F- 13						
95807-12200	E- 3	97707-50130	C- 4						
95817-08620	B- 2	97707-60018	D- 8						
95704-08500	F- 10	97780-40525	F- 13						
95707-05500	D- 11	97801-03008	E- 9						
95707-08500	D- 12	97890-04010	C- 5						
	E- 10	98502-04008	F- 12						
95804-08025	E- 4	98502-04012	F- 2						
95804-08035	E- 4	98504-05025	F- 14						
95807-08010	D- 13	98507-04010	F- 11						
	G- 3	98507-04014	C- 5						
95807-08012	G- 3	98507-05008	E- 15						
95807-08014	E- 10	98507-05010	C- 6						
95807-08020	G- 2		C- 7						
95807-08025	E- 8	98507-05012	C- 6						
95807-12018	C- 10		F- 11						
95814-08045	C- 9	98507-08018	C- 11						
95814-08070	C- 9		F- 8						
95814-08090	C- 9	98507-08030	F- 8						
95814-08045	C- 9	98517-08012	F- 4						
95814-08080	C- 9		F- 5						
95817-08012	C- 2	98580-04008	C- 5						
	C- 3	98704-05012	F- 12						
95817-08018	D- 13	98704-08018	C- 11						
95817-08095	C- 9	98708-04018	F- 3						
95817-08025	B- 9	98707-05008	C- 7						
95817-08050	C- 9	98780-05010	F- 4						