

YAMAHA

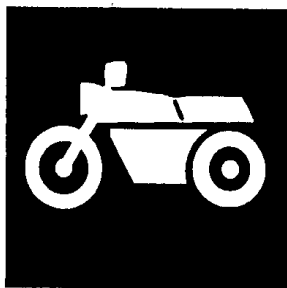

**PARTS
CATALOGUE**

WR250ZG (4JW3)

WR250Z'95 (4JW3)

WR250Z (4JW4)

ALL

YAMAHA
GENUINE
Parts & Accessories

154JW-100E1

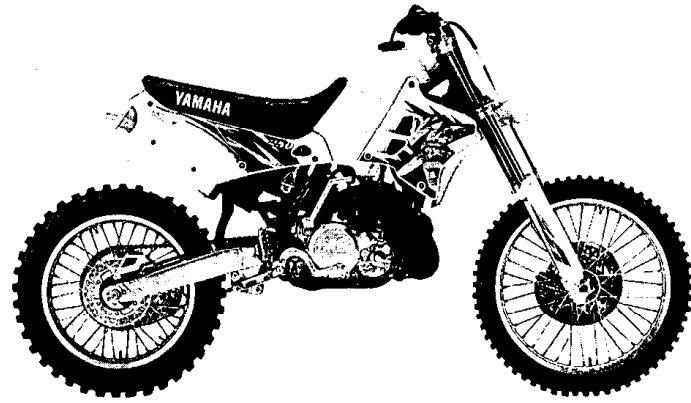

A3

FOREWORD

This Parts Catalogue is related to the parts for the model(s) in the below frame. When you are ordering replacement parts, please refer to this Parts Catalogue and quote both part numbers and part names correctly.

WR250ZG/WR250Z*95 (4JW3), WR250Z (4JW4)

1. Modifications or additions which have been made after issue of the Parts Catalogue will be announced in the Yamaha Parts News. It is advisable that you make necessary corrections to the Parts Catalogue according to the Yamaha Parts News.

2. Abbreviations

The following abbreviations are used in this Parts Catalogue.

- "UR" Use specified parts number.
- "UN" Use as many as needed.
- "AP" Alternate Parts
- "LM" Local Made (Parts need to be ordered locally)
- "F#" Frame No. (Applicable machine No.)

3. Parts, which are to be supplied in an assembly, are listed with a dot (.) in front of the part name as shown below.

EXAMPLE

- CARBURETOR ASSY
- . JET, PILOT
- . NOZZLE, MAIN

4. Number of component for assembly

The numeral appearing to the right of each component part indicates the quantity of parts for each assembly unit.

EXAMPLE

PART NO.	DESCRIPTION	Q'TY	REMARKS
2F5-83310-60	FRONT FLASHER LIGHT ASSY	2	
115-83311-60	. BULB (6V-18W)	1	

5. Applicable colors of graphics are represented in the "REMARKS" as shown below.

PART NO.	DESCRIPTION	Q'TY	REMARKS
2N4-24110-00-X5	FUEL TANK COMP.	1	MAXIM RED
3J1-24240-10	. GRAPHIC, FUEL TANK	1	for MXR

6. Applicable Serial No. and Color Code

4JW3	①	Frame Serial No.	4JW-011101	~
	②	Engine Serial No.	4JW-011101	~
4JW4	①	Frame Serial No.	4JW-016101	~
	②	Engine Serial No.	4JW	~

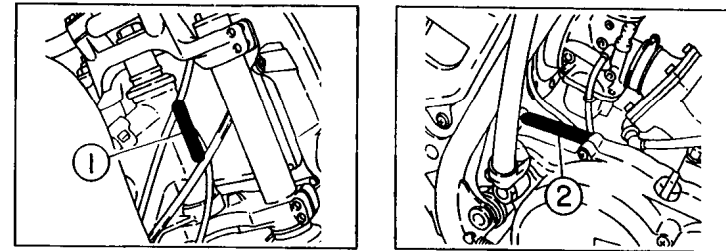

Color Code	Color Name	Abbreviation
0206	PURPLISH WHITE SOLID 1	PWS1

7. Note that the illustrations are for reference in finding parts numbers, not to be used for assembling. When assembling, please use the applicable service manual.
8. The asterisk (*) before a reference number indicates modification items after the first edition.

CONTENTS

ENGINE

Cylinder Head	B2~B3
Governor	B4
Crankshaft, Piston	B5
Water Pump	B6
Radiator, Hose	B7
Intake	B8
Carburetor	B9~B10
Exhaust	B11
Crankcase	B12
Crankcase Cover 1	B13
Starter	B14
Clutch	B15
Transmission	C2~C3
Shift Cam, Fork	C4
Shifter	C5

CHASSIS

Frame	C6~C7
Fender	C8
Side Cover	C9~C10
Rear Arm	C11~C12
Rear Suspension	C13
Steering	C14
Front Fork	C15~D3
Fuel Tank	D4
Seat	D5
Front Wheel	D6
Front Brake Caliper	D7
Rear Wheel	D8

Rear Brake Caliper	D9
Steering Handle, Cable	D10
Front Master Cylinder	D11
Stand, Footrest	D12
Rear Master Cylinder	D13
Generator	D14
Handle Switch, Lever	D15
Electrical 1	E2

ALTERNATE PARTS

Alternate (Chassis)	E3
---------------------------	----

REPAIR KIT

Repair Kit	E4
------------------	----

INDEX

Numerical Index	M1~M3
-----------------------	-------

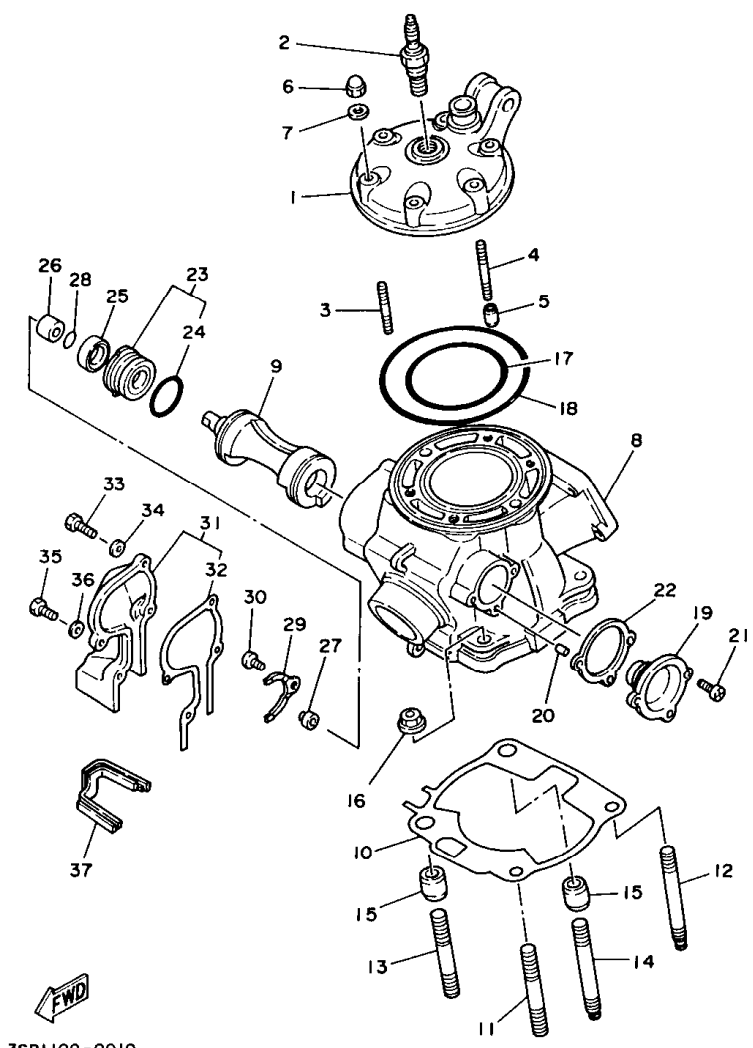
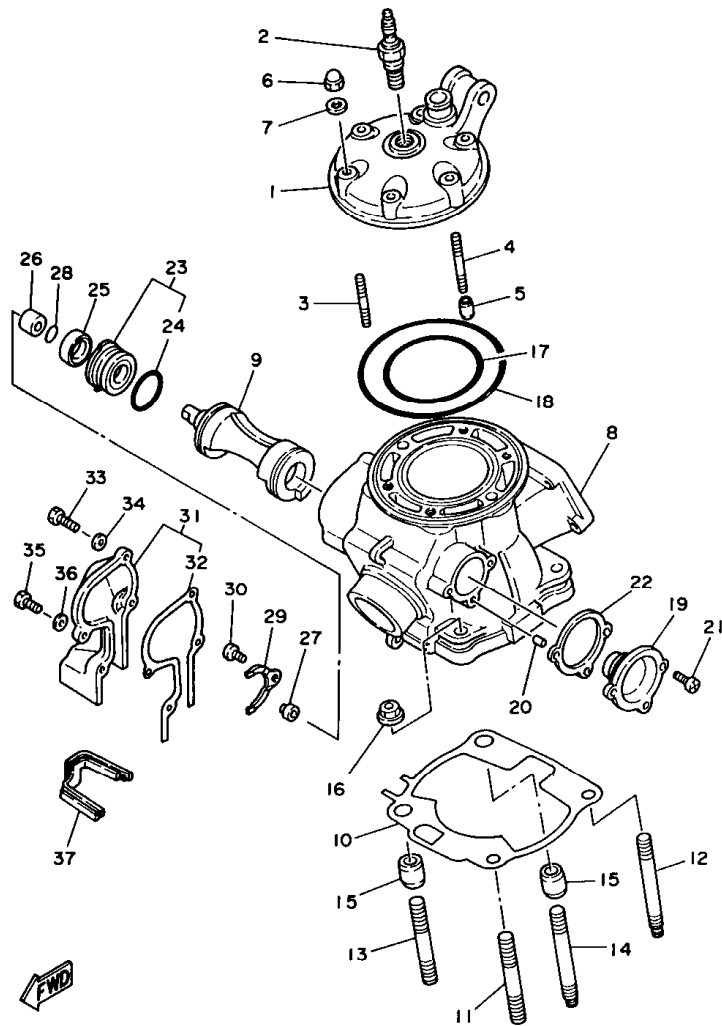

FIG. 1 CYLINDER HEAD

REF. NO.	PART NO.	DESCRIPTION	Q'TY	REMARKS
1	4EW-11111-00	HEAD, CYLINDER 1	1	
2	94702-00323	PLUG, SPARK (NGK BR8EG)	1	UR
	94702-00326	PLUG, SPARK (NGK BR8EG)	1	UR FOR CANADA
	94709-00323	PLUG, SPARK (NGK BR8EG)	1	UR FOR JAPAN
3	90116-08394	BOLT, STUD	4	
4	90116-08392	BOLT, STUD	2	
5	99510-10114	PIN, DOWEL	2	
6	90176-08026	NUT, CROWN	6	
7	90201-08087	WASHER, PLATE	6	
8	4JX-11311-00	CYLINDER 1	1	
9	4JX-1131A-00	VALVE 1	1	
10	2VM-11351-10	GASKET, CYLINDER	1	
11	90116-10314	BOLT, STUD	1	
12	90116-10547	BOLT, STUD	1	
13	90116-10314	BOLT, STUD	1	
14	90116-10547	BOLT, STUD	1	
15	99530-14016	PIN, DOWEL	2	
16	95707-10500	NUT, FLANGE	4	
17	93210-77363	O-RING	1	
18	93211-11770	O-RING	1	
19	3JE-Y113E-00	HOLDER 1	1	
20	93604-08071	PIN, DOWEL	1	
21	98507-05012	SCREW, PAN HEAD	2	
22	3JE-1131N-10	GASKET, HOLDER	1	
23	5X4-Y113F-10	HOLDER 2 ASSY	1	
24	93210-270A8	O-RING	1	
25	93104-16074	OIL SEAL	1	
26	90387-102W0	COLLAR	1	

B2



FWD
3SP1100-0010

FIG. 1 CYLINDER HEAD

REF. NO.	PART NO.	DESCRIPTION	Q'TY	REMARKS
27	3JE-11937-00	BOSS, LEVER	1	
28	93210-09192	O-RING	1	
29	1LX-11915-00	PLATE, THRUST 1	1	
30	98507-05008	SCREW, PAN HEAD	1	
31	3SP-11992-10	HOUSING 2	1	
32	3SP-11993-10	GASKET	1	
33	97007-05020	BOLT	2	
34	92907-05600	WASHER, PLATE	2	
35	97007-05016	BOLT	2	
36	92907-05600	WASHER, PLATE	2	
37	2VM-11995-00	SEAL, HOUSING	1	

B3

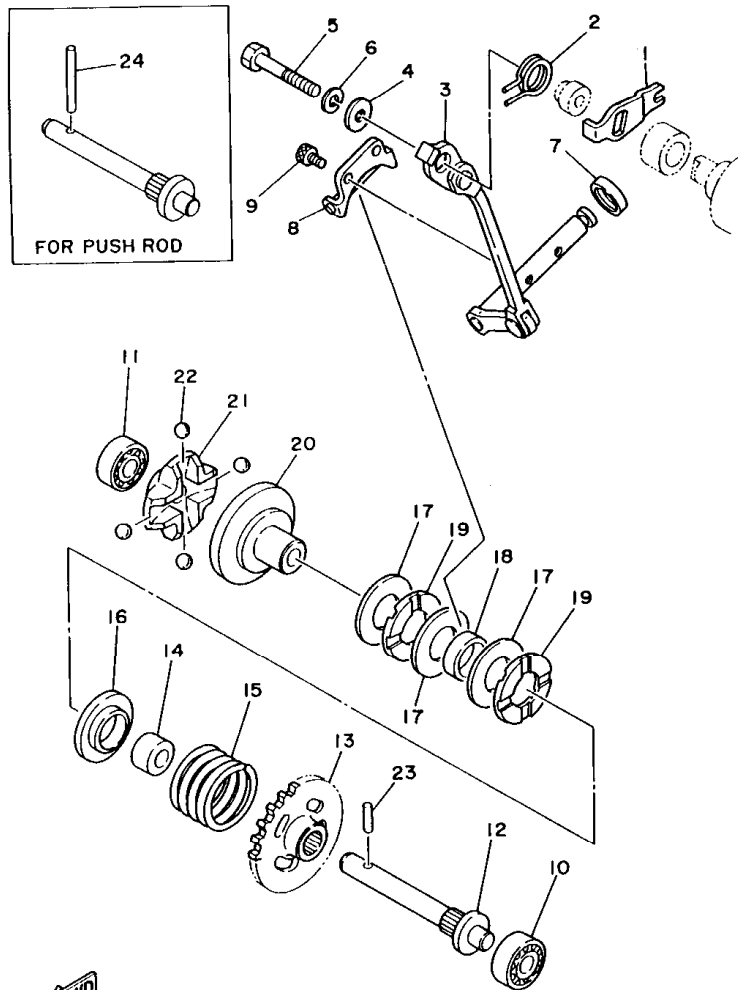

4EW1100-3020

FIG. 2 GOVERNOR

REF. NO.	PART NO.	DESCRIPTION	Q'TY	REMARKS
1	3JE-11931-01	LEVER	1	
2	90508-14783	SPRING, TORSION	1	
3	3SP-11990-00	PUSH ROD ASSY	1	
4	90201-057H5	WASHER, PLATE	1	
5	97007-05030	BOLT	1	
6	92907-05100	WASHER, SPRING	1	
7	93104-08040	OIL SEAL	1	
8	3JE-11922-00	FORK, GOVERNOR	1	
9	91317-04006	BOLT	2	
10	93300-60814	BEARING (608M4ML01)	1	NMB
11	93300-60814	BEARING (608M4ML01)	1	NMB
12	5X4-11921-02	SHAFT, GOVERNOR	1	
13	24X-11953-01	GEAR, GOVERNOR	1	
14	90560-08213	SPACER	1	
15	90501-240F4	SPRING, COMPRESSION	1	
16	5X4-11952-00	PLATE	1	
17	90201-154E9	WASHER, PLATE	3	
18	90387-152F2	COLLAR	1	
19	93340-21505	BEARING, THRUST	2	
20	5X5-11912-01	RETAINER, WEIGHT	1	
21	5X5-11911-01	RETAINER	1	
22	93521-64032	BALL	4	
23	93603-14179	PIN, DOWEL	1	
24	93604-29184	PIN, DOWEL	1	AP FOR PUSH ROD

B4

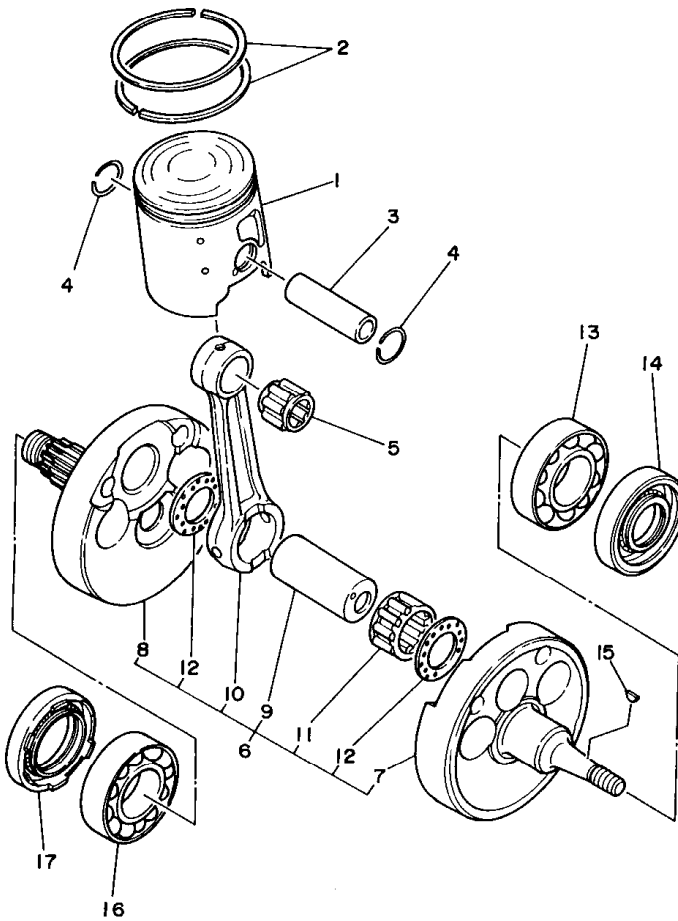

3SP1100-0030

FIG. 3 CRANKSHAFT. PISTON

REF. NO.	PART NO.	DESCRIPTION	Q'TY	REMARKS
1	4EW-11631-01-A0	PISTON (STD)	1	UR RED
	4EW-11631-01-B0	PISTON (STD)	1	UR ORANGE
	4EW-11631-01-C0	PISTON (STD)	1	UR GREEN
	4EW-11631-01-D0	PISTON (STD)	1	UR PURPLE
2	4JX-11603-00	PISTON RING SET (STD)	1	
3	2VM-11633-01	PIN, PISTON	1	
4	93450-19052	CIRCLIP	2	
5	93310-418E9	BEARING, CYLINDRICAL	1	
6	4JX-11400-00	CRANKSHAFT ASSY	1	
7	4JX-11412-00	.CRANK 1	1	
8	4JX-11422-00	.CRANK 2	1	
9	3JE-11681-01	.PIN, CRANK 1	1	
10	5X5-11651-03	.ROD, CONNECTING	1	
11	93310-425P2	.BEARING, CYLINDRICAL	1	
12	90209-25085	.WASHER	2	
13	93306-37802	BEARING	1	
14	93102-22363	OIL SEAL	1	
15	90280-03017	KEY, WOODRUFF	1	
16	93306-37802	BEARING	1	
17	93103-40091	OIL SEAL	1	

B5

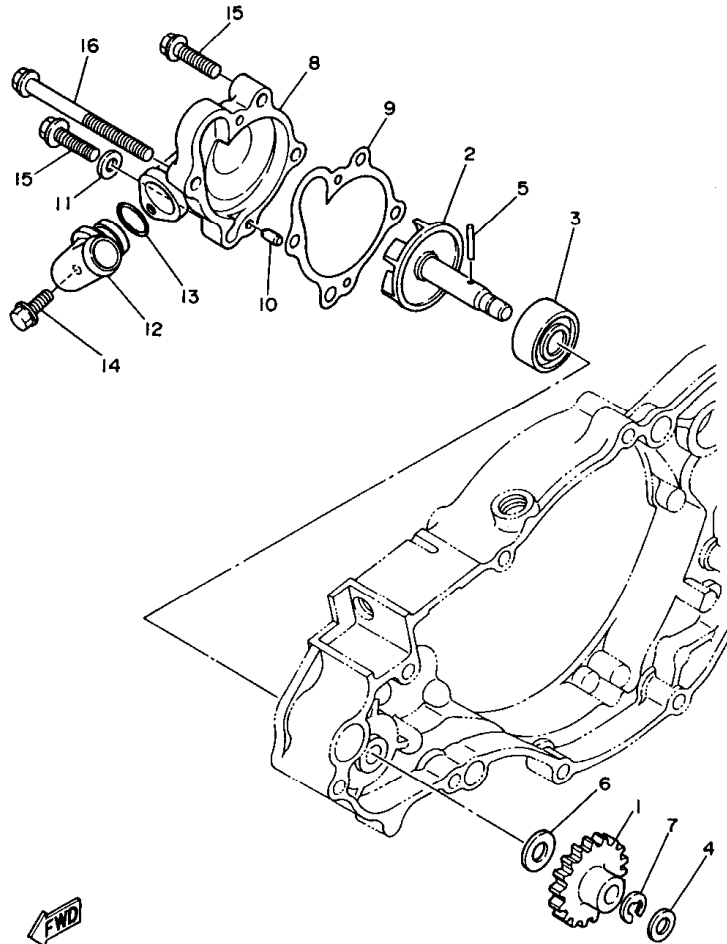

FIG. 4 WATER PUMP

REF. NO.	PART NO.	DESCRIPTION	Q'TY	REMARKS
1	2VM-12459-00	GEAR, IMPELLER SHAFT	1	
2	2VM-12450-00	IMPELLER SHAFT ASSY	1	
3	93103-10168	OIL SEAL	1	
4	90201-08759	WASHER, PLATE	1	
5	93603-22028	PIN, DOWEL	1	
6	90201-08784	WASHER, PLATE	1	
7	99009-06600	CIRCLIP	1	
8	3SP-12422-00	COVER, HOUSING	1	
9	2VM-12428-10	GASKET, HOUSING COVER 2	1	
10	93604-10011	PIN, DOWEL	2	
11	90430-06166	GASKET	1	
12	10V-12469-01	JOINT 1	1	
13	93210-16275	O-RING	1	
14	95027-06025	BOLT, FLANGE	1	
15	95027-06025	BOLT, FLANGE	3	
16	95027-06080	BOLT, FLANGE	1	



3SP1100-0040

B6

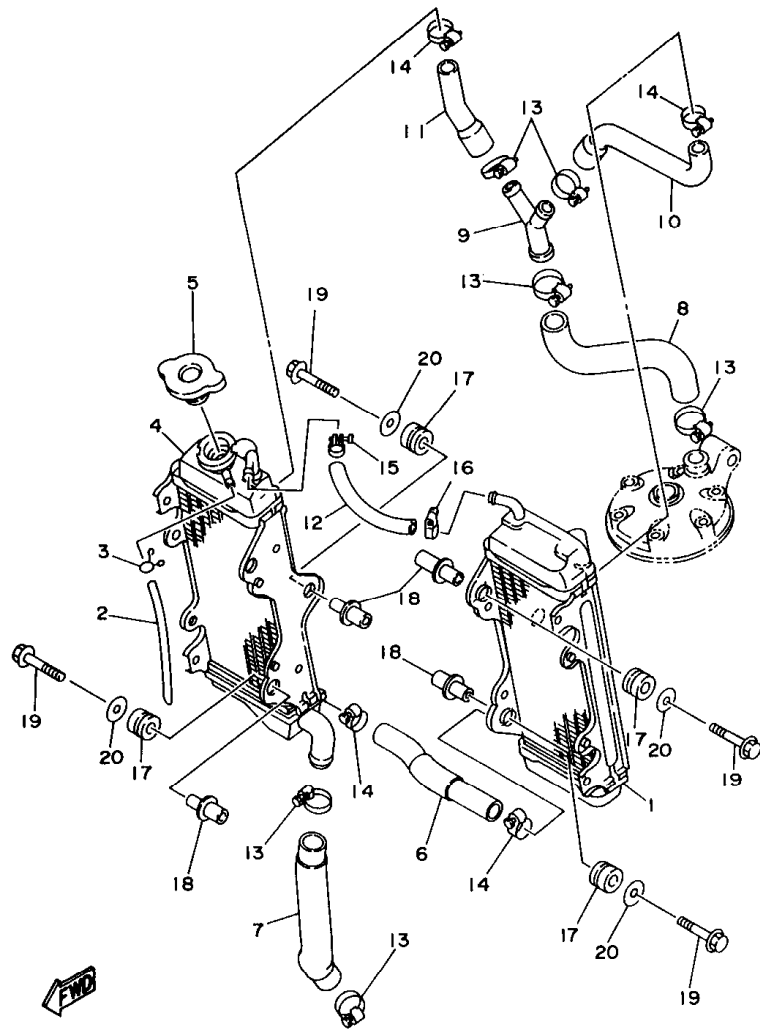

4JW3100-5050

FIG. 5 RADIATOR. HOSE

REF. NO.	PART NO.	DESCRIPTION	Q'TY	REMARKS
1	4EW-1240A-01	RADIATOR ASSY	1	
2	91A20-05065	TUBE, FLEXIBLE VINYL	1	
3	90467-09006	CLIP	1	
4	4JW-12461-00	RADIATOR ASSY	1	
5	22W-12462-00	CAP, RADIATOR	1	
6	4JW-12482-00	PIPE 2	1	
7	4JW-12483-00	PIPE 3	1	
8	4JW-12485-00	PIPE 5	1	
9	24X-12469-00	JOINT 1	1	
10	4JW-12476-00	PIPE 6	1	
11	4EW-12477-00	PIPE 7	1	
12	4JW-1248A-00	PIPE 8	1	
13	90450-28014	HOSE CLAMP ASSY	6	
14	90450-22052	HOSE CLAMP ASSY	4	
15	90450-15041	HOSE CLAMP ASSY	1	
16	90450-17036	HOSE CLAMP ASSY	1	
17	90480-15528	GROMMET	6	
18	90560-07382	SPACER	6	
19	95027-06050	BOLT, FLANGE	6	
20	90201-063J2	WASHER, PLATE	6	

B7

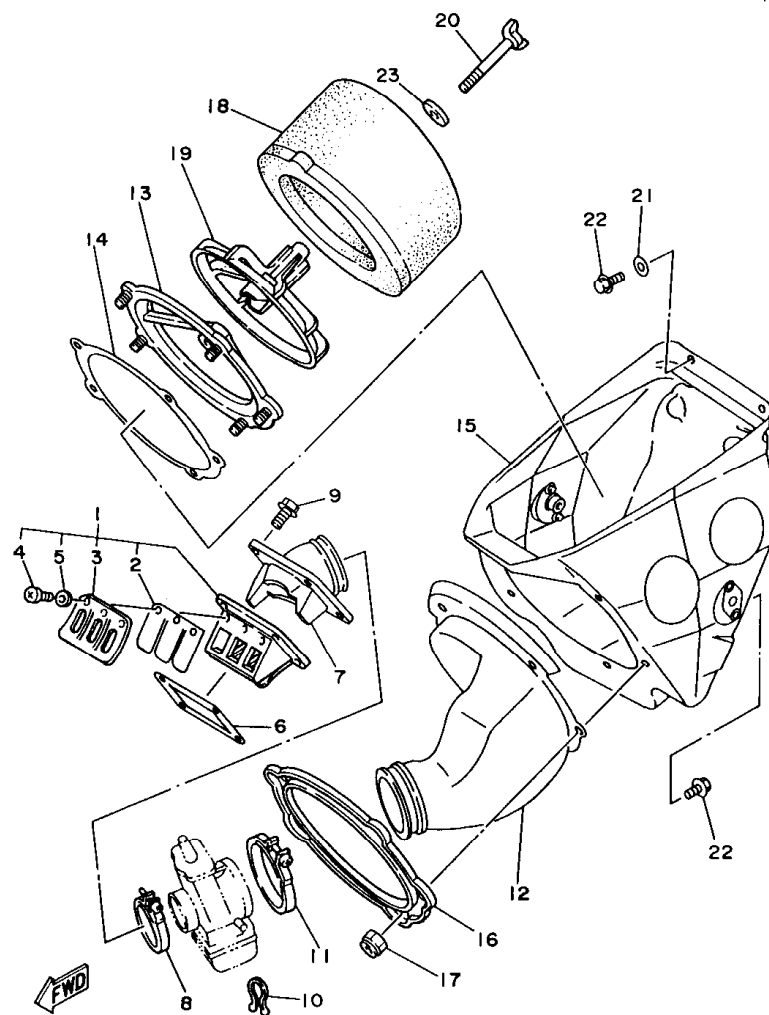

4JW1100-4060

FIG. 6 INTAKE

REF. NO.	PART NO.	DESCRIPTION	Q'TY	REMARKS
1	4DC-13610-00	REED VALVE ASSY	1	
2	3SP-13613-00	.REED, VALVE	2	
3	4DA-13616-00	.STOPPER, REED VALVE	2	
4	98507-03008	.SCREW, PAN HEAD	6	
5	92990-03100	.WASHER, SPRING	6	
6	2K7-13621-10	GASKET, VALVE SEAT	1	
7	4DC-13565-00	JOINT, CARBURETOR	1	
8	90450-51070	CLAMP, HOSE	1	
9	95027-06020	BOLT, FLANGE	4	
10	90464-16039	CLAMP	1	
11	90450-70072	HOSE CLAMP ASSY	1	
12	4JW-14453-00	JOINT, AIR CLEANER 1	1	
13	3JD-14459-00	HOLDER, GUIDE	1	
14	3JD-14462-00	SEAL	1	
15	4JW-14411-01	CASE, AIR CLEANER 1	1	
16	3JD-14477-00	PLATE	1	
17	95607-05100	NUT, U	5	
18	4PE-14451-00	ELEMENT, AIR CLEANER	1	
19	3JD-14458-00	GUIDE	1	
20	90122-06035	BOLT, WING	1	
21	90201-06380	WASHER, PLATE	2	
22	90105-06639	BOLT, WASHER BASED	2	
23	90209-06096	WASHER	1	

B8

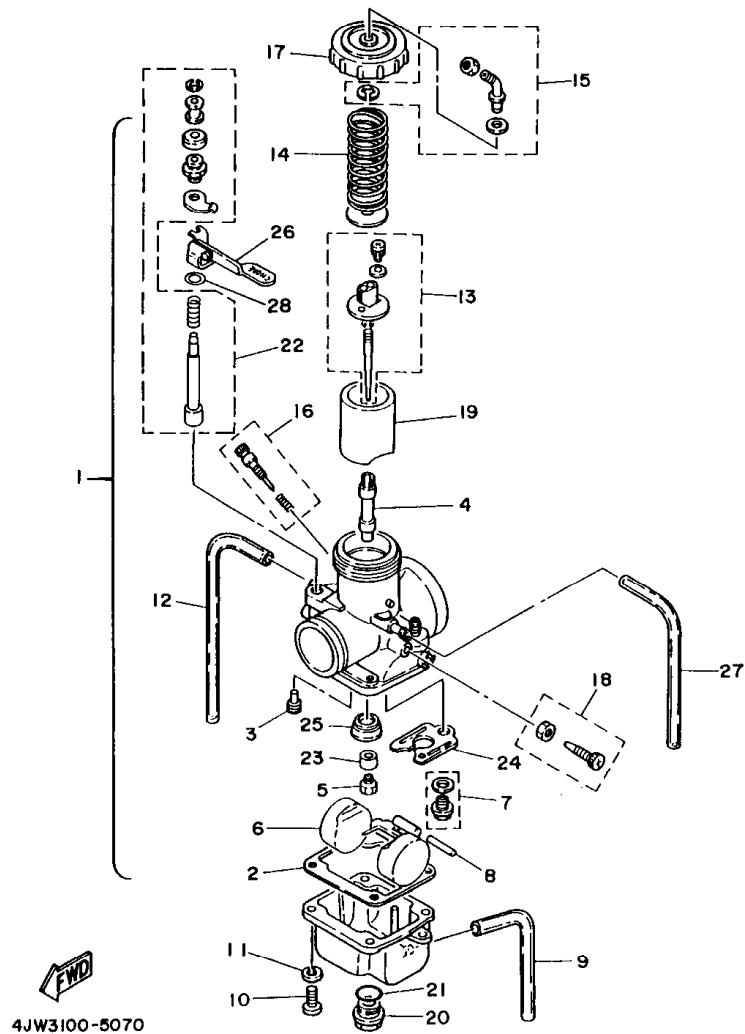

FIG. 7 CARBURETOR

REF. NO.	PART NO.	DESCRIPTION	Q'TY	REMARKS
1	4JW-14101-10	CARBURETOR ASSY 1	1	
2	363-14184-00	.GASKET, FLOAT CHAMBER	1	
3	193-14142-40-A1	.JET, PILOT (#40)	1	STD
	193-14142-35	.JET, PILOT (#35)	1	AP
	193-14142-45-A1	.JET, PILOT (#45)	1	AP
4	510-14141-R2	.NOZZLE, MAIN	1	STD
	510-14141-R0	.NOZZLE, MAIN	1	AP
	510-14141-R4	.NOZZLE, MAIN	1	AP
5	137-14143-78	.JET, MAIN (#390)	1	STD
	137-14143-76	.JET, MAIN (#380)	1	AP
	137-14143-80	.JET, MAIN (#400)	1	AP
6	2N7-14185-00	.FLOAT	1	
7	23X-14107-35	.NEEDLE VALVE SET	1	
8	537-14186-00	.PIN, FLOAT	1	
9	510-14197-00	.PIPE	1	
10	98507-05016	.SCREW, PAN HEAD	4	
11	92901-05100	.WASHER, SPRING	4	
12	2HH-14197-00	.PIPE	1	
13	23X-1490J-00	.NEEDLE SET	1	
14	431-14131-00	.SPRING, THROTTLE VALVE	1	
15	23X-14106-00	.CABLE ADJUST SCREW SET	1	
16	23X-14104-00	.AIR SCREW SET	1	
17	5Y9-14158-00	.TOP, MIXING CHAMBER	1	
18	23X-14103-00	.THROTTLE SCREW SET	1	
19	2X8-14112-40	.VALVE, THROTTLE 1	1	STD
	2X8-14112-35	.VALVE, THROTTLE 1	1	AP
	2X8-14112-45	.VALVE, THROTTLE 1	1	AP
20	510-14115-00	.PLUG, SCREW	1	

B9

4JW3100-5070

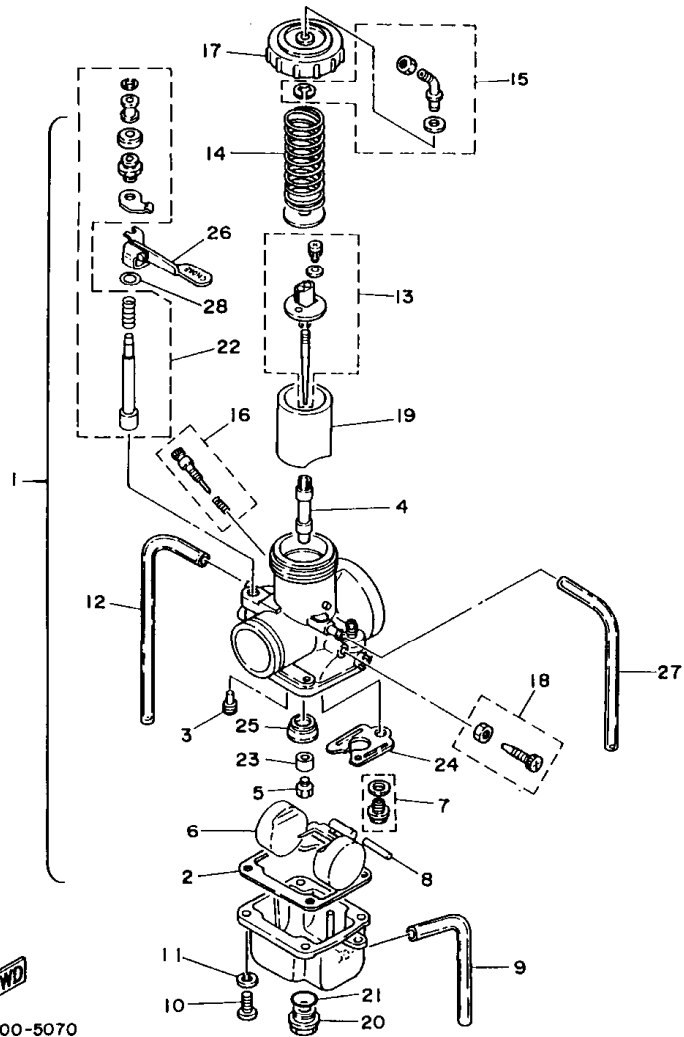

FIG. 7 CARBURETOR

REF. NO.	PART NO.	DESCRIPTION	Q'TY	REMARKS
21	558-14147-00	.O-RING	1	
22	26A-1410A-00	.STARTER SET	1	
23	5X5-14153-00	.WASHER, MAIN JET	1	
24	3R4-14146-00	.PLATE	1	
25	509-14145-00	.SETTER, NEEDLE JET	1	
26	1W3-14175-00	.LEVER, STARTER I	1	
27	35P-14149-00	.PIPE	1	
28	256-14954-00	.WASHER	1	

B10

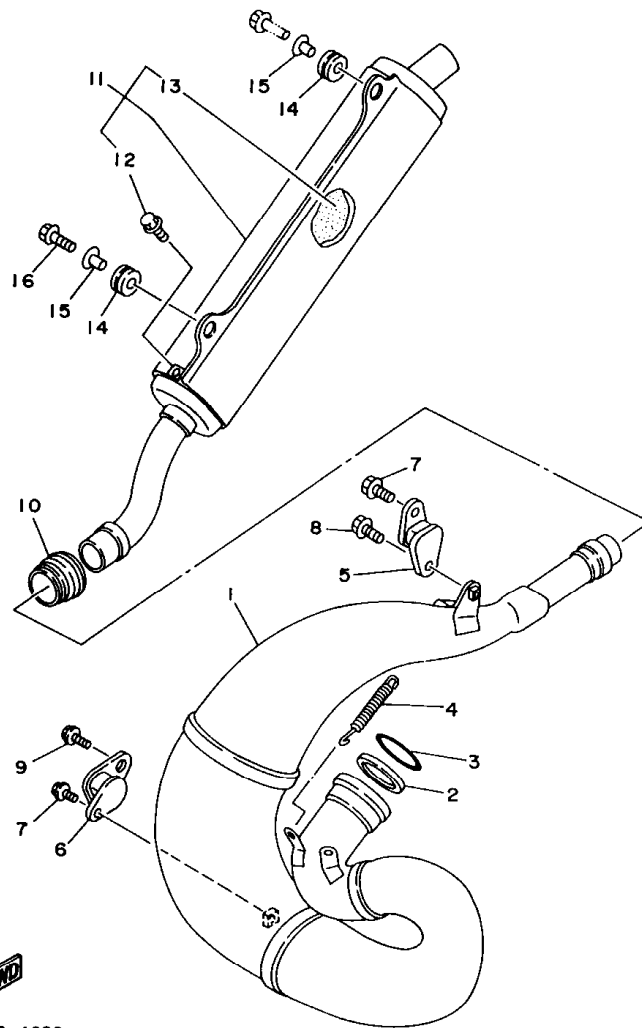
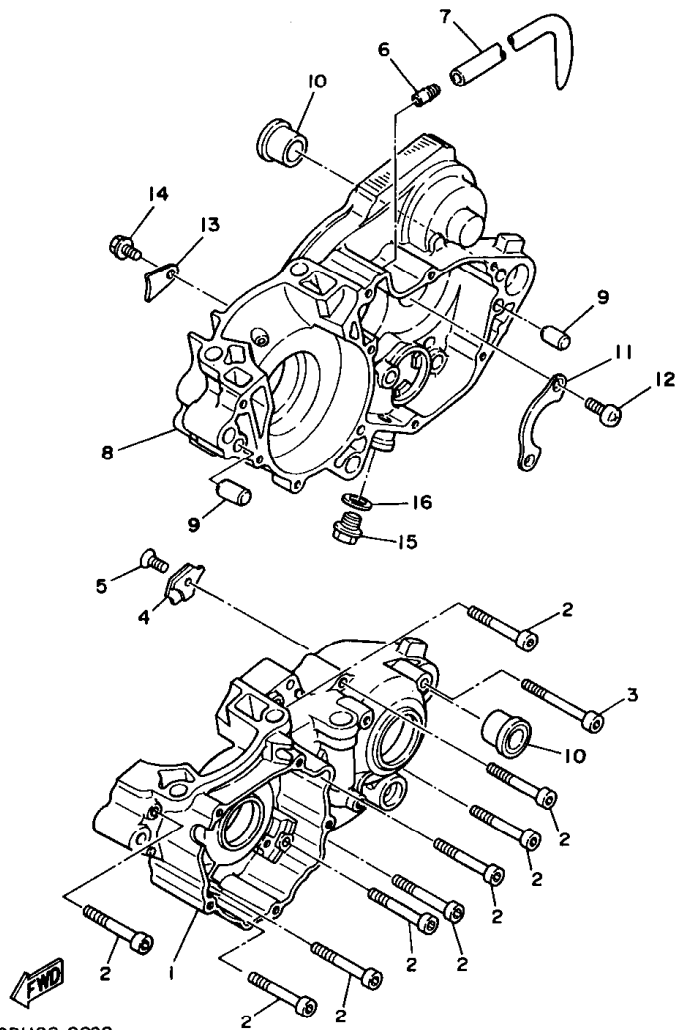

FIG. 8 EXHAUST

REF. NO.	PART NO.	DESCRIPTION	Q'TY	REMARKS
1	4EW-14610-02	EXHAUST PIPE ASSY 1	1	
2	3R4-14613-00	GASKET, EXHAUST PIPE	1	
3	93210-56743	O-RING	1	
4	90507-20052	SPRING, TENSION	3	
5	565-14771-00	STAY, MUFFLER 1	1	
6	483-14781-02	STAY, MUFFLER 2	1	
7	95027-06012	BOLT, FLANGE	2	
8	90119-06185	BOLT, WITH WASHER	1	
9	95027-08012	BOLT, FLANGE	1	
10	3JE-14615-01	JOINT, EXHAUST 1	1	
11	4EW-14753-01	SILENCER, EXHAUST	1	
12	92017-06010	.SCREW	2	
13	4EW-1469A-01	.FIBER	1	
14	90480-16561	GROMMET	2	
15	90387-063G3	COLLAR	2	
16	95027-06025	BOLT, FLANGE	1	

4JX1100-4080

B11



3SP1100-0090

FIG. 9 CRANKCASE

REF. NO.	PART NO.	DESCRIPTION	Q'TY	REMARKS
1	2VM-15111-05	CRANKCASE 1	1	
2	91317-06050	BOLT	9	
3	91317-06070	BOLT	1	
4	3SP-15381-00	PLATE, BEARING COVER	1	
5	98707-06012	SCREW, FLAT HEAD	1	
6	353-13115-01	CONNECTOR, SUCTION PIPE	1	
7	90445-086A8	HOSE	1	
8	2VM-15121-02	CRANKCASE 2	1	
9	99510-12016	PIN, DOWEL	2	
10	90387-160H4	COLLAR	2	
11	4L0-17471-00	PLATE, COVER	1	
12	98507-06012	SCREW, PAN HEAD	2	
13	4V4-15118-00	HOLDER	1	
14	95807-06010	BOLT, FLANGE	1	
15	90340-12097	PLUG, STRAIGHT SCREW	1	
16	90430-12207	GASKET	1	

B12

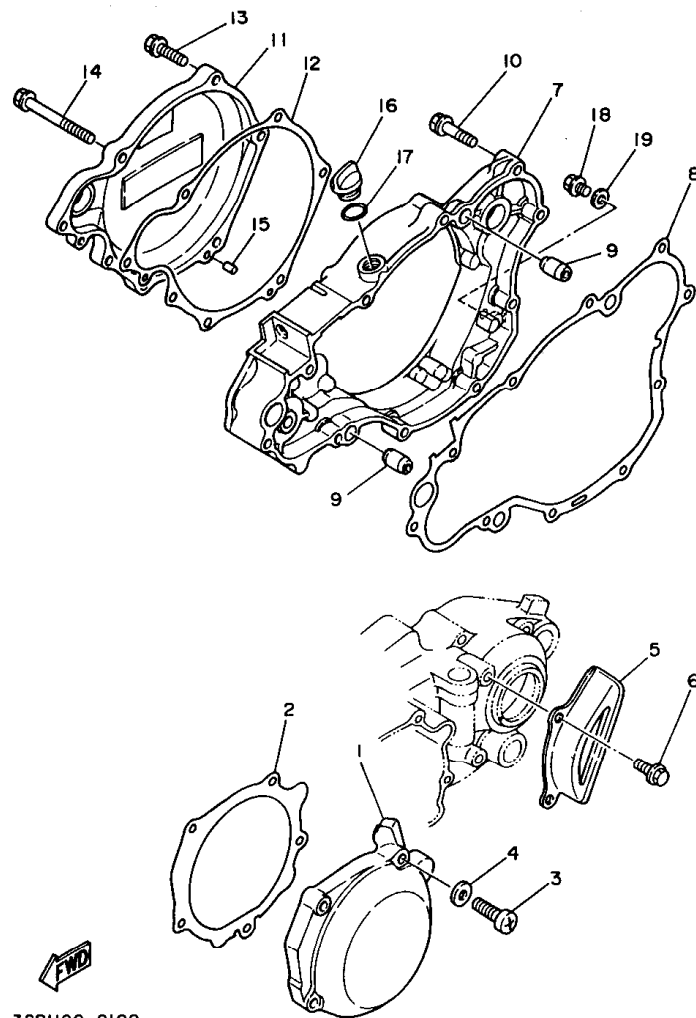
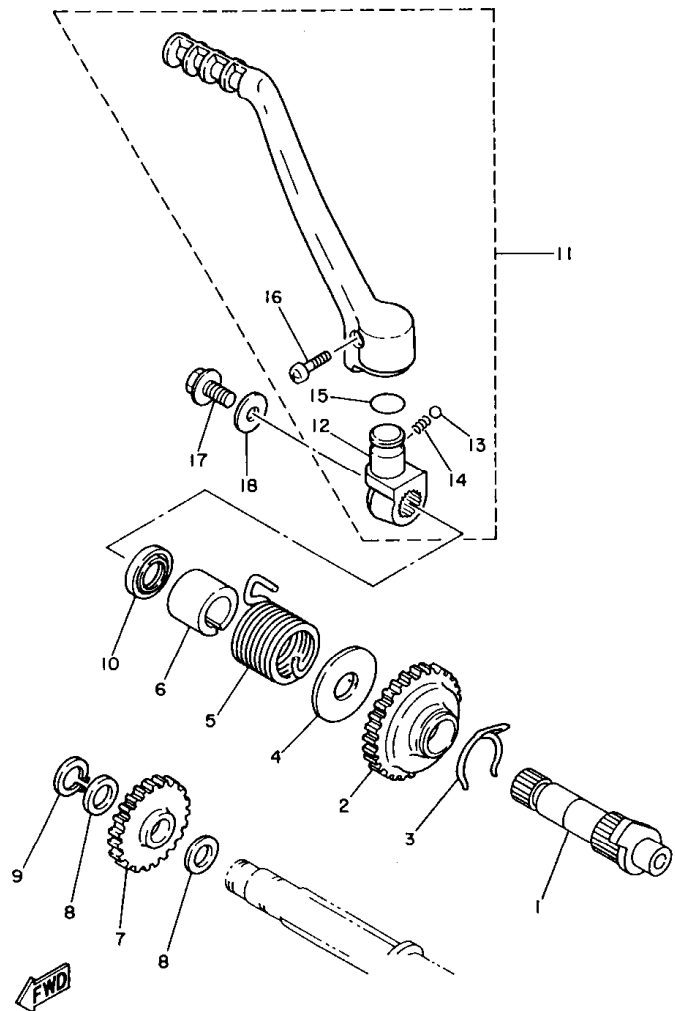

FIG. 10 CRANKCASE COVER 1

REF. NO.	PART NO.	DESCRIPTION	Q'TY	REMARKS
1	2VM-15411-00	COVER, CRANKCASE 1	1	
2	2VM-15451-10	GASKET, CRANKCASE COVER 1	1	
3	98507-06030	SCREW, PAN HEAD	5	
4	92907-06600	WASHER	5	
5	2VM-15421-02	COVER, CRANKCASE 2	1	
6	95027-06012	BOLT, FLANGE	2	
7	3SP-Y1543-00	COVER, CRANKCASE 3	1	
8	2VM-15462-10	GASKET, CRANKCASE COVER 3	1	
9	99510-12016	PIN, DOWEL	2	
10	95027-06030	BOLT, FLANGE	7	
11	4EW-15415-00	COVER, GENERATOR	1	
12	3SP-15463-11	GASKET, CARBURETOR COVER 2	1	
13	95027-06025	BOLT, FLANGE	5	
14	95027-06070	BOLT, FLANGE	2	
15	93604-10011	PIN, DOWEL	2	
16	1G8-15362-00	PLUG, OIL LEVEL	1	
17	93210-14104	O-RING	1	
18	95027-06008	BOLT, FLANGE	1	
19	90430-06014	GASKET	1	

B13



4JW1100-4110

FIG. 11 STARTER

REF. NO.	PART NO.	DESCRIPTION	Q'TY	REMARKS
1	4JW-15660-00	KICK AXLE ASSY	1	
2	3R4-15641-00	GEAR, KICK (26T)	1	
3	90468-26048	CLIP	1	
4	90201-20358	WASHER, PLATE	1	
5	90508-30743	SPRING, TORSION	1	
6	2VM-15664-00	GUIDE, SPRING	1	
7	38V-15651-00	GEAR, KICK IDLE (23T)	1	
8	90201-17545	WASHER, PLATE	2	
9	99009-17400	CIRCLIP	1	
10	93102-20309	OIL SEAL	1	
11	4JW-15620-00	KICK CRANK ASSY	1	
12	3SP-15621-02	.BOSS, KICK CRANK	1	
13	93501-04011	.BALL	1	
14	90501-13720	.SPRING, COMPRESSION	1	
15	93210-19216	.O-RING	1	
16	90157-06048	.SCREW, PAN HEAD	1	
17	95027-08020	BOLT, FLANGE	1	
18	90201-087A9	WASHER, PLATE	1	

B14

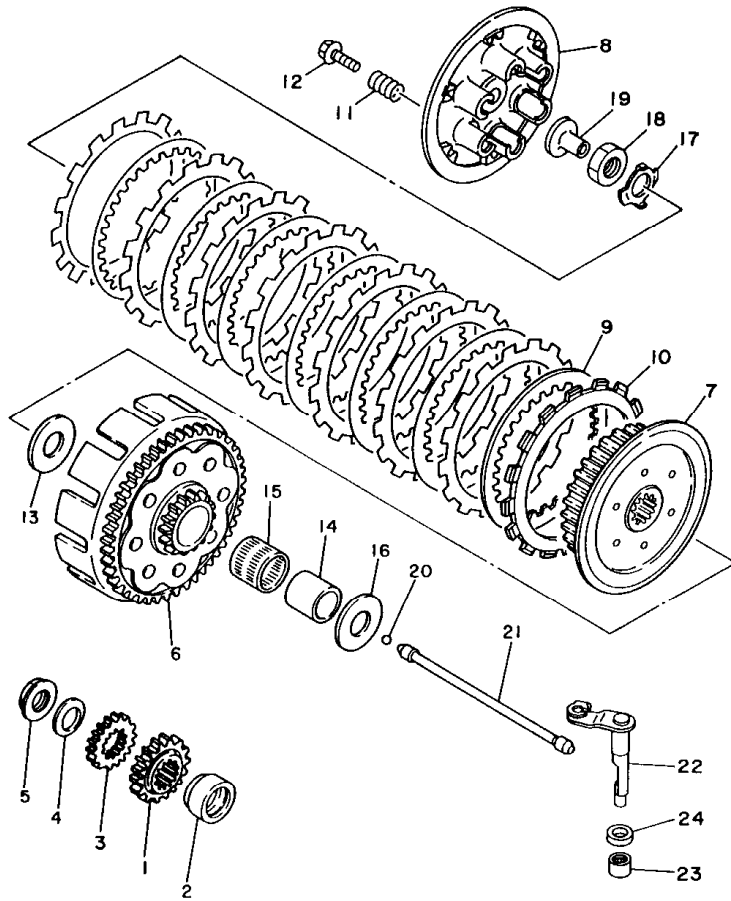

FWD
4JX1100-4120

FIG. 12 CLUTCH

REF. NO.	PART NO.	DESCRIPTION	Q'TY	REMARKS
1	2VM-16111-00	GEAR, PRIMARY DRIVE	1	
2	90387-252F6	COLLAR	1	
3	3XK-11956-00	GEAR, GOVERNOR DRIVE	1	
4	90208-18025	WASHER, CONICAL SPRING	1	
5	90179-18172	NUT	1	
6	4EW-16150-00	PRIMARY DRIVEN GEAR COMP.	1	
7	4EW-16371-01	BOSS, CLUTCH	1	
8	4EW-16351-00	PLATE, PRESSURE 1	1	
9	4X7-16325-00	PLATE, CLUTCH 2	7	
10	3XK-16321-00	PLATE, FRICTION	8	
11	90501-23598	SPRING, COMPRESSION	6	
12	90159-06016	SCREW, WITH WASHER	6	
13	2K7-16154-00	PLATE, THRUST 1	1	
14	2VM-16181-00	SPACER 1	1	
15	93310-230T7	BEARING, CYLINDRICAL	1	
16	3SP-16154-00	PLATE, THRUST 1	1	
17	90215-20231	WASHER, LOCK	1	
18	90170-20255	NUT	1	
19	4EW-16356-00	ROD, PUSH 1	1	
20	93511-32027	BALL	1	
21	4EW-16357-00	ROD, PUSH 2	1	
22	4EW-16381-01	PUSH LEVER COMP.	1	
23	93315-11206	BEARING, CYLINDRICAL	1	
24	93102-12224	OIL SEAL	1	

B15

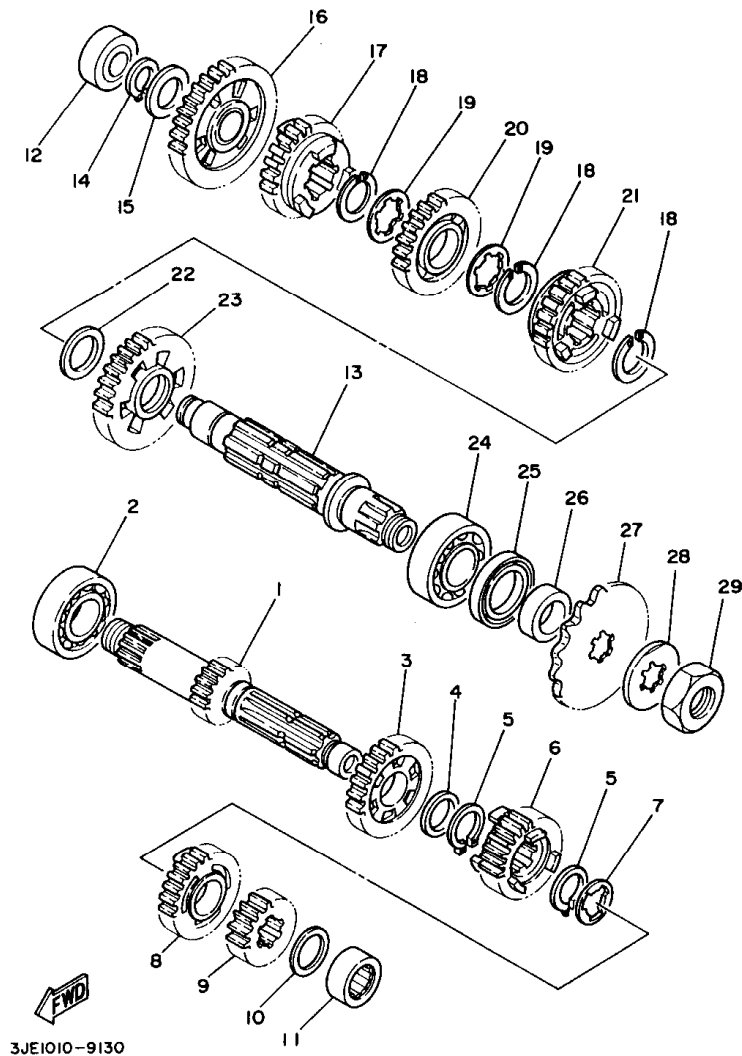

FIG. 13 TRANSMISSION

REF. NO.	PART NO.	DESCRIPTION	Q'TY	REMARKS
1	4JW-17411-00	AXLE, MAIN	1	
2	93306-20576	BEARING	1	
3	3RB-17151-00	GEAR, 5TH PINION (25T)	1	
4	90201-22555	WASHER, PLATE	1	
5	93410-22039	CIRCLIP	2	
6	3RB-17131-00	GEAR, 3RD PINION	1	
7	90209-18135	WASHER	1	
8	3RB-17141-10	GEAR, 4TH PINION	1	
9	2VM-17121-01	GEAR, 2ND PINION	1	
10	90209-17311	WASHER	1	
11	93311-41734	BEARING, CYLINDRICAL	1	
12	93311-62035	BEARING, CYLINDRICAL	1	
13	2VM-17421-01	AXLE, DRIVE	1	
14	93410-20038	CIRCLIP	1	
15	90201-20278	WASHER, PLATE	1	
16	3RB-17211-00	GEAR, 1ST WHEEL (32T)	1	
17	3RB-17251-00	GEAR, 5TH WHEEL (21T)	1	
18	93440-25084	CIRCLIP	3	
19	90209-22082	WASHER (0.5T)	2	
20	3RB-17231-00	GEAR, 3RD WHEEL	1	
21	3RB-17241-10	GEAR, 4TH WHEEL	1	
22	90201-253K0	WASHER, PLATE (T=1.0)	1	
23	2VM-17221-00	GEAR, 2ND WHEEL (29T)	1	
24	93306-20562	BEARING	1	
25	93102-32M07	OIL SEAL	1	
26	90387-25663	COLLAR	1	
27	93834-14049	SPROCKET, DRIVE 14T (1W41746140)	1	STD
	93834-13030	SPROCKET, DRIVE 13T (23X1746130)	1	AP

C2

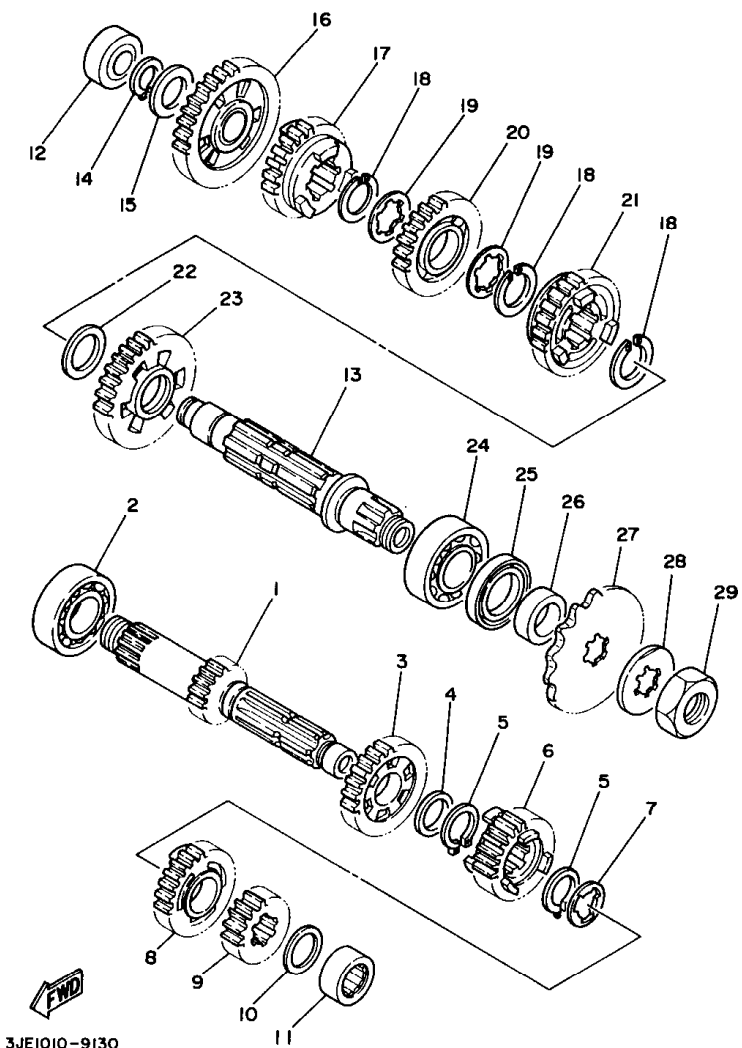

FIG. 13 TRANSMISSION

REF. NO.	PART NO.	DESCRIPTION	Q'TY	REMARKS
27	93834-15075	SPROCKET,DRIVE 15T (1W41746150)	1	AP
28	90215-21239	WASHER, LOCK	1	
29	90179-20255	NUT	1	

C3

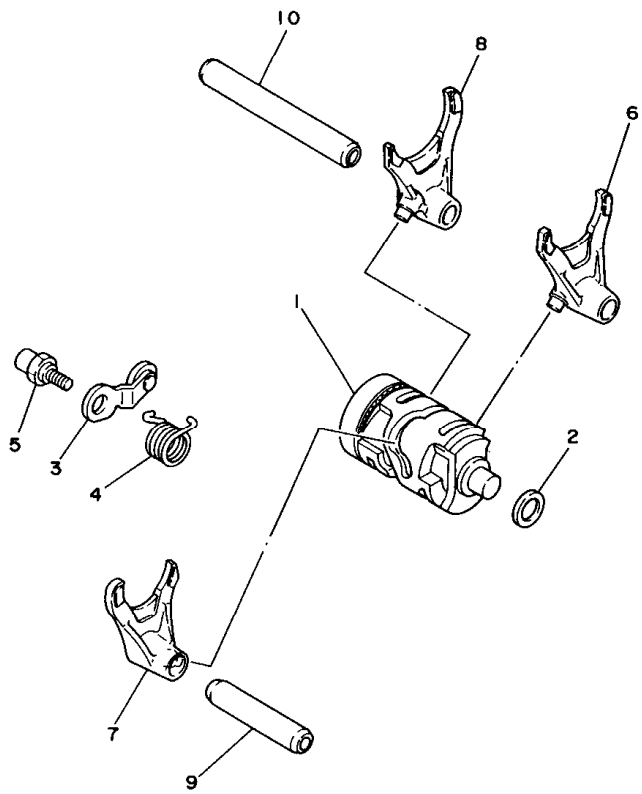

FIG. 14 SHIFT CAM. FORK

REF. NO.	PART NO.	DESCRIPTION	Q'TY	REMARKS
1	3XK-18540-01	SHIFT CAM ASSY	1	
2	90201-12166	WASHER, PLATE	1	
3	3XK-18140-00	STOPPER LEVER ASSY	1	
4	90508-26561	SPRING, TORSION	1	
5	3XK-18177-00	BOLT, STOPPER	1	
6	2VM-18511-00	FORK, SHIFT 1	1	
7	2VM-18512-00	FORK, SHIFT 2	1	
8	2VM-18513-00	FORK, SHIFT 3	1	
9	4EX-18531-00	BAR, SHIFT FORK GUIDE 1	1	
10	3XV-18535-00	BAR, SHIFT FORK GUIDE 2	1	



3XK1100-1140

C4

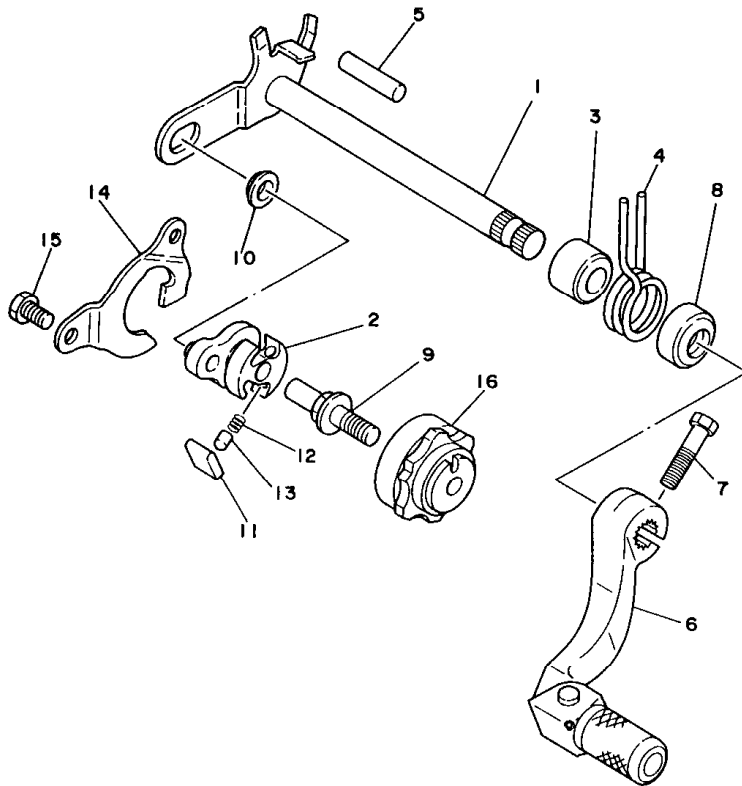

FIG. 15 SHIFTER

REF. NO.	PART NO.	DESCRIPTION	Q'TY	REMARKS
1	3XK-18101-01	SHIFT SHAFT ASSY	1	
2	3XK-18122-00	LEVER, SHIFT 2	1	
3	90560-12280	SPACER	1	
4	90508-291A8	SPRING, TORSION	1	
5	93608-33046	PIN, DOWEL	1	
6	2VM-18110-00	SHIFT PEDAL ASSY	1	
7	97017-06025	BOLT	1	
8	93102-12106	OIL SEAL	1	
9	3XJ-18173-00	PIN, SHIFT	1	
10	3XJ-18178-00	ROLLER, SHIFT LEVER	1	
11	3XJ-18182-00	PAWL, SHIFTER	2	
12	90501-052G5	SPRING, COMPRESSION	2	
13	3XJ-18184-00	PIN, PAWL	2	
14	4DA-18172-00	GUIDE, SHIFT	1	
15	90101-06664	BOLT	2	
16	4EW-18185-00	SEGMENT	1	



4DA2100-2150

C5

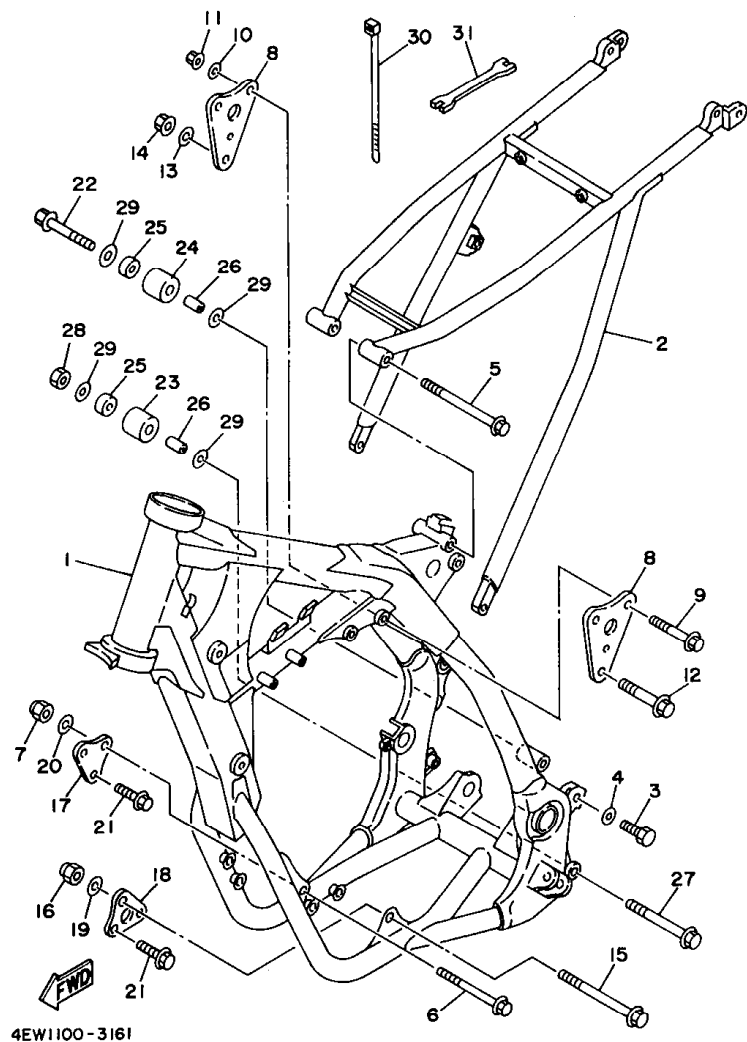
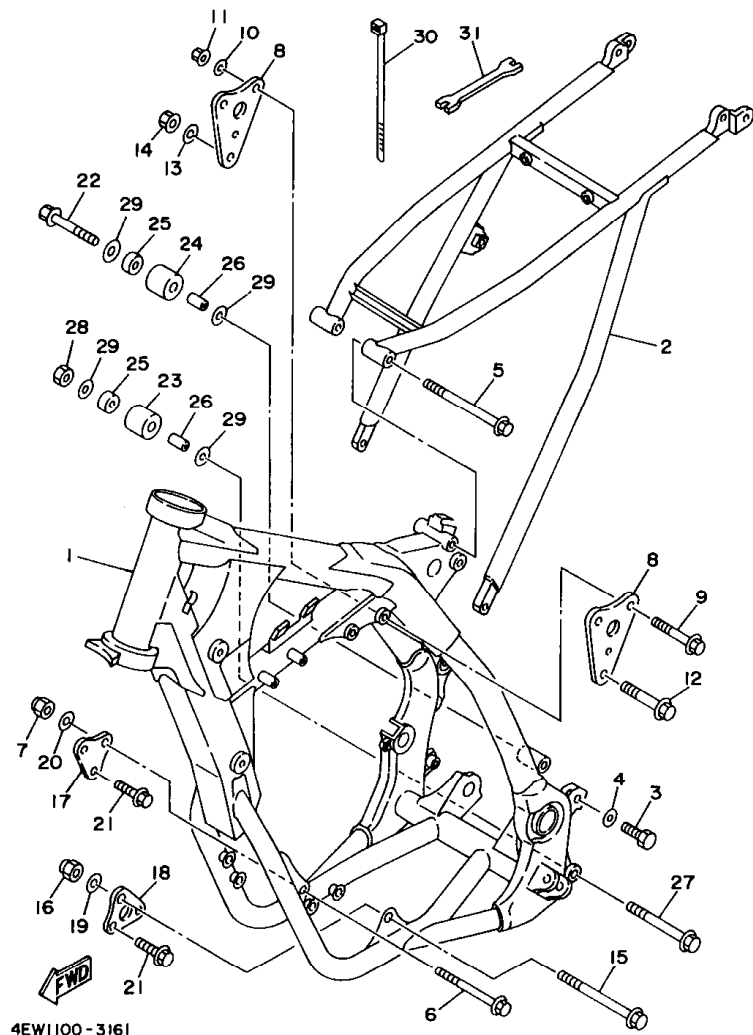

FIG. 16 FRAME

REF. NO.	PART NO.	DESCRIPTION	Q'TY	REMARKS
1	4JX-21101-00-G3	FRONT FRAME COMP.	1	FRENCH BLUE
2	4JX-21190-01-G3	REAR FRAME COMP.	1	FRENCH BLUE
3	90106-08051	BOLT	2	
4	90201-080E2	WASHER, PLATE	2	
5	90105-08120	BOLT, WASHER BASED	1	
6	90105-08592	BOLT, WASHER BASED	1	
7	95617-08100	NUT, U	1	
8	4EW-21425-00	BRACKET, REAR UPPER 1	2	
9	95817-08050	BOLT, FLANGE	2	
10	90201-08730	WASHER, PLATE	2	
11	95607-08200	NUT, SELF-LOCKING	2	
12	95817-10055	BOLT, FLANGE	1	
13	92907-10200	WASHER, PLAIN	1	
14	95617-10100	NUT, U	1	
15	90105-10733	BOLT, WASHER BASED	1	
16	95617-10200	NUT, SELF-LOCKING	1	
17	4EW-21417-00	BRACKET, FRONT LOWER 1	1	
18	4EW-21427-00	BRACKET, REAR LOWER 1	1	
19	90201-08326	WASHER, PLATE	1	
20	90201-101J1	WASHER, PLATE	1	
21	95817-08035	BOLT, FLANGE	4	
22	95027-08040	BOLT, FLANGE	1	
23	3JD-22178-10	TENSIONER	1	
24	4EW-22178-00	TENSIONER	1	
25	93300-60804	BEARING	2	
26	90387-086N4	COLLAR	2	
27	95027-08065	BOLT, FLANGE	1	
28	95317-08700	NUT	1	

C6



4EW1100-3161

FIG. 16 FRAME

REF. NO.	PART NO.	DESCRIPTION	Q'TY	REMARKS
29	90201-086P8	WASHER, PLATE	4	
30	12R-82591-00	BAND	1	
31	56A-28166-00	WRENCH, HEXAGON	1	

C7

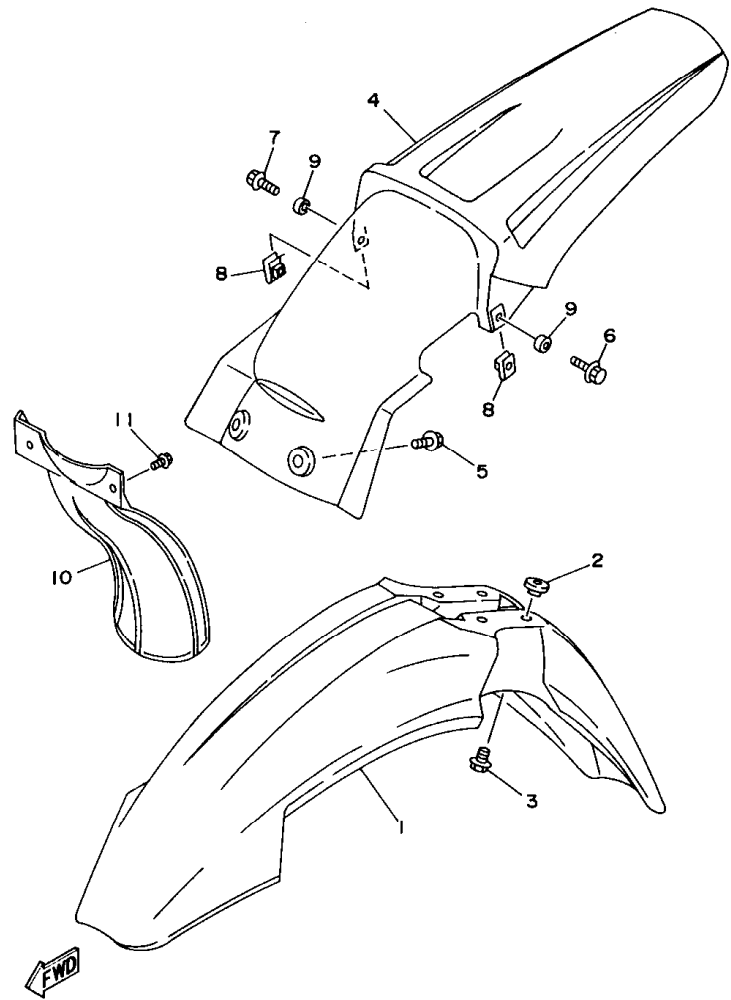

4EW1100-3170

FIG. 17 FENDER

REF. NO.	PART NO.	DESCRIPTION	Q'TY	REMARKS
1	4DA-21511-00	FENDER, FRONT	1	
2	3JD-21748-00	COLLAR	4	
3	90119-06063	BOLT, WITH WASHER	4	
4	4EW-21611-00	FENDER, REAR	1	
5	90119-06185	BOLT, WITH WASHER	2	
6	95027-06016	BOLT, FLANGE	1	
7	95027-06030	BOLT, FLANGE	1	
8	90183-06023	NUT, SPRING	2	
9	90387-0701A	COLLAR	2	
10	39X-21642-00	GUARD, FLAP	1	
11	90119-06185	BOLT, WITH WASHER	2	

C8

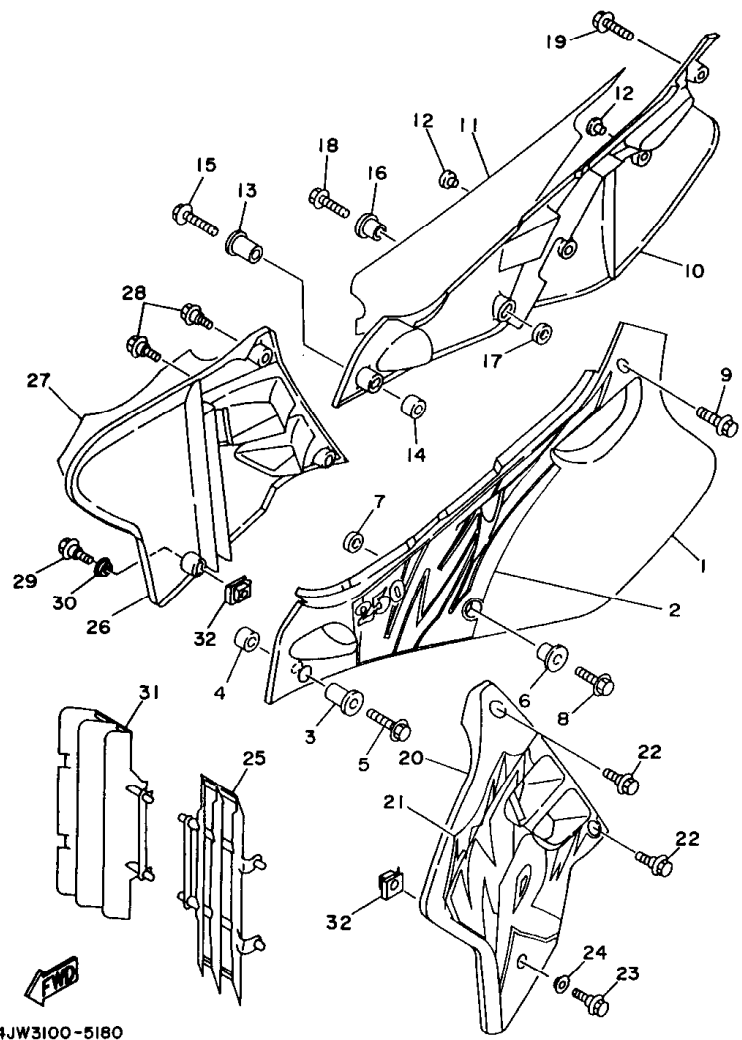

4JW3100-5180

FIG. 18 SIDE COVER

REF. NO.	PART NO.	DESCRIPTION	Q'TY	REMARKS
1	4EW-21711-01	COVER, SIDE 1	1	
2	4JW-2173E-11	GRAPHIC 1	1	
3	90387-0602Y	COLLAR	1	
4	90387-1003E	COLLAR	1	
5	95027-06025	BOLT, FLANGE	1	
6	90387-0602X	COLLAR	1	
7	90387-1003F	COLLAR	1	
8	95027-06020	BOLT, FLANGE	1	
9	90119-06225	BOLT, WITH WASHER	1	
10	4EW-21721-01	COVER, SIDE 2	1	
11	4JW-2173F-11	GRAPHIC 2	1	
12	22W-24181-00	DAMPER, LOCATING 1	2	
13	90387-0602Y	COLLAR	1	
14	90387-1003E	COLLAR	1	
15	95027-06025	BOLT, FLANGE	1	
16	90387-0602X	COLLAR	1	
17	90387-1003F	COLLAR	1	
18	95027-06020	BOLT, FLANGE	1	
19	90119-06225	BOLT, WITH WASHER	1	
20	4EW-21731-00	COVER, SIDE 3	1	
21	4JW-21783-11	EMBLEM 3	1	
22	90109-067F4	BOLT	2	
23	95027-06014	BOLT, FLANGE	1	
24	90387-0603J	COLLAR	1	
25	4EW-2172A-00	PANEL 1	1	
26	4EW-21741-00	COVER, SIDE 4	1	
27	4JW-2173G-11	EMBLEM SET 1	1	
28	90109-067F4	BOLT	2	

C9

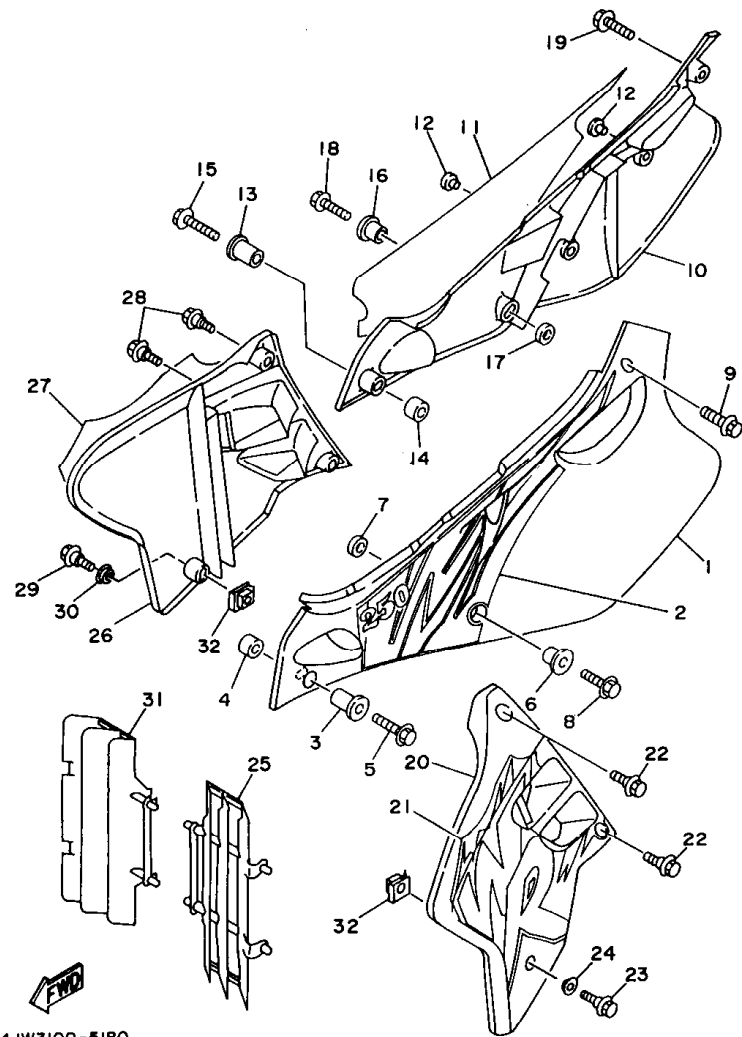

4JW3100-5180

FIG. 18 SIDE COVER

REF. NO.	PART NO.	DESCRIPTION	Q'TY	REMARKS
29	95027-06014	BOLT, FLANGE	1	
30	90387-0603J	COLLAR	1	
31	4EW-2172A-00	PANEL 1	1	
32	90183-06069	NUT, SPRING	2	

C10

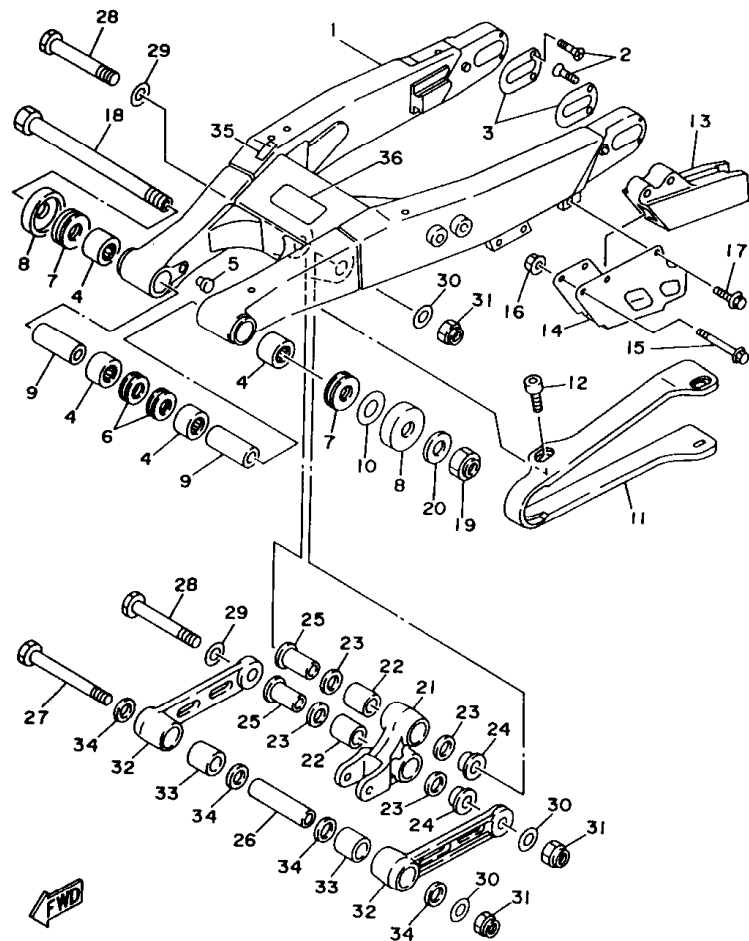

4JW3100-5190

FIG. 19 REAR ARM

REF. NO.	PART NO.	DESCRIPTION	Q'TY	REMARKS
1	4JW-22110-00	REAR ARM COMP.	1	
2	90151-04048	SCREW, COUNTERSUNK	4	
3	4JW-22355-00	PATCH A	2	
4	93317-22262	BEARING, CYLINDRICAL	4	
5	90338-10150	PLUG	2	
6	93106-22019	OIL SEAL (DC 22-28-8)	2	
7	93342-22215	BEARING, THRUST	2	
8	4EW-22129-00	COVER, THRUST 2	2	
9	90380-16158	BUSH, SOLID	2	
10	156-22127-00	SHIM (0.3T)	1 UN	
11	4EW-22151-01	SEAL, GUARD	1	
12	90110-05201	BOLT, HEXAGON SOCKET HEAD	4	
13	4EW-22199-01	SUPPORT, CHAIN	1	
14	4MX-22128-00	COVER, THRUST 1	1	
15	95027-06045	BOLT, FLANGE	2	
16	90179-06568	NUT	2	
17	95027-06010	BOLT, FLANGE	1	
18	1LX-22141-00	SHAFT, PIVOT	1	
19	90185-16127	NUT, SELF-LOCKING	1	
20	90201-164H4	WASHER, PLATE	1	
21	4EW-2217A-00	ARM, RELAY	1	
22	93315-22046	BEARING, CYLINDRICAL	2	
23	93109-20029	OIL SEAL	4	
24	90387-164N2	COLLAR	2	
25	90387-164N3	COLLAR	2	
26	90387-167Y9	COLLAR	1	
27	90109-147F2	BOLT	1	
28	90109-142F4	BOLT	2	

C11

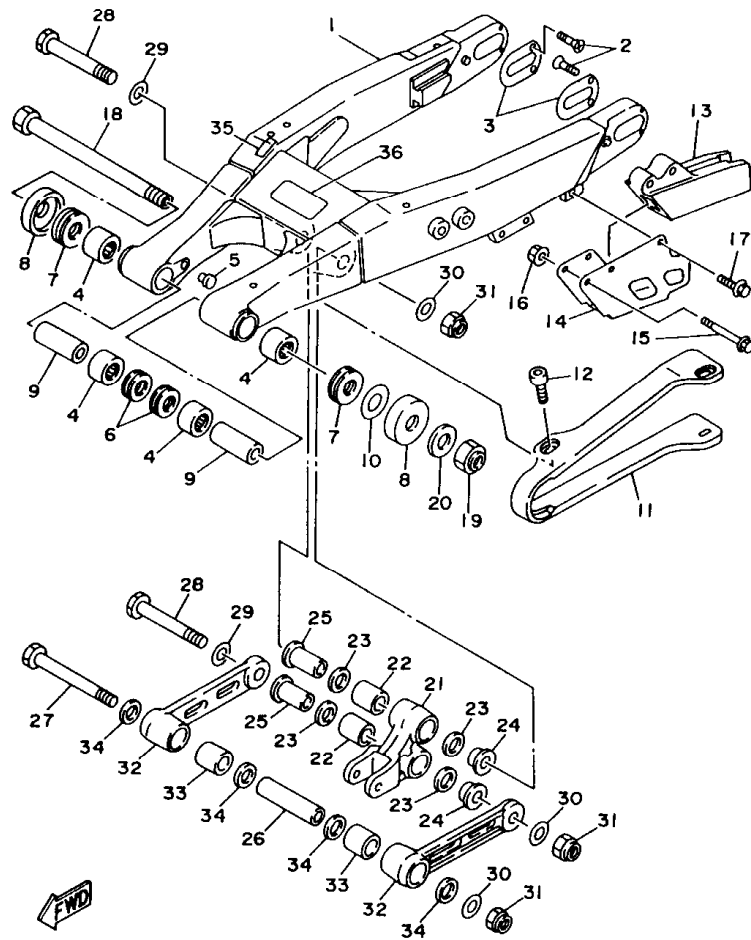

4JW3100-5190

FIG. 19 REAR ARM

REF. NO.	PART NO.	DESCRIPTION	Q'TY	REMARKS
29	90201-164H4	WASHER, PLATE	2	
30	90201-14740	WASHER, PLATE	3	
31	90185-14070	NUT, SELF-LOCKING	3	
32	4EW-2217F-00	ROD, CONNECTING 1	2	
33	93315-22046	BEARING, CYLINDRICAL	2	
34	93109-20029	OIL SEAL	4	
35	46X-21269-00	SEAL	1	
36	3XJ-21668-10	LABEL, TIRE	1	FOR JAPAN

C12

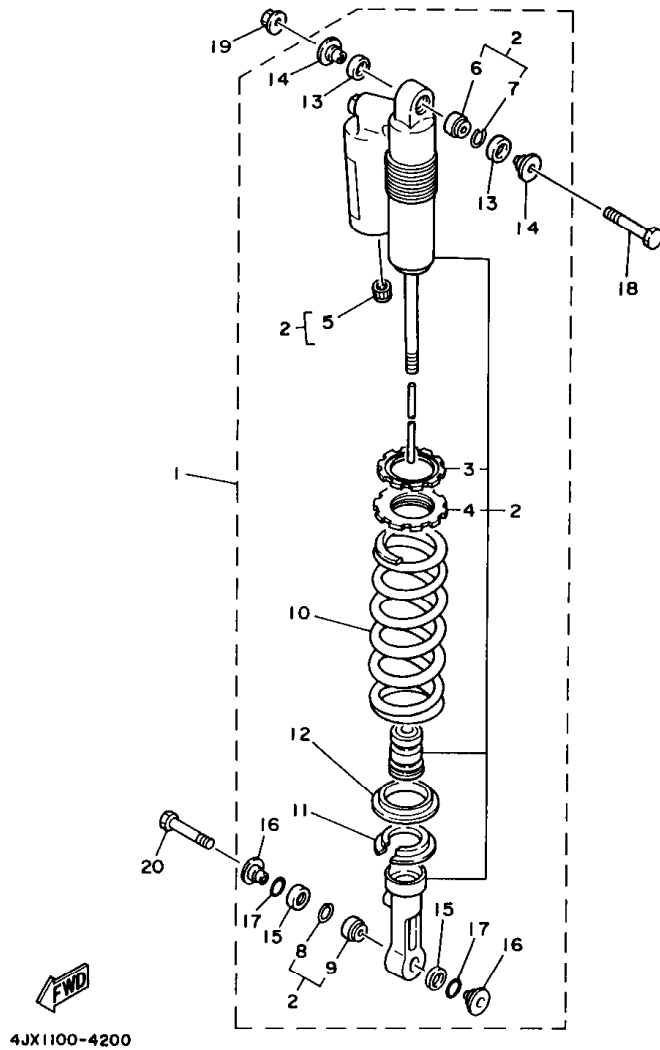
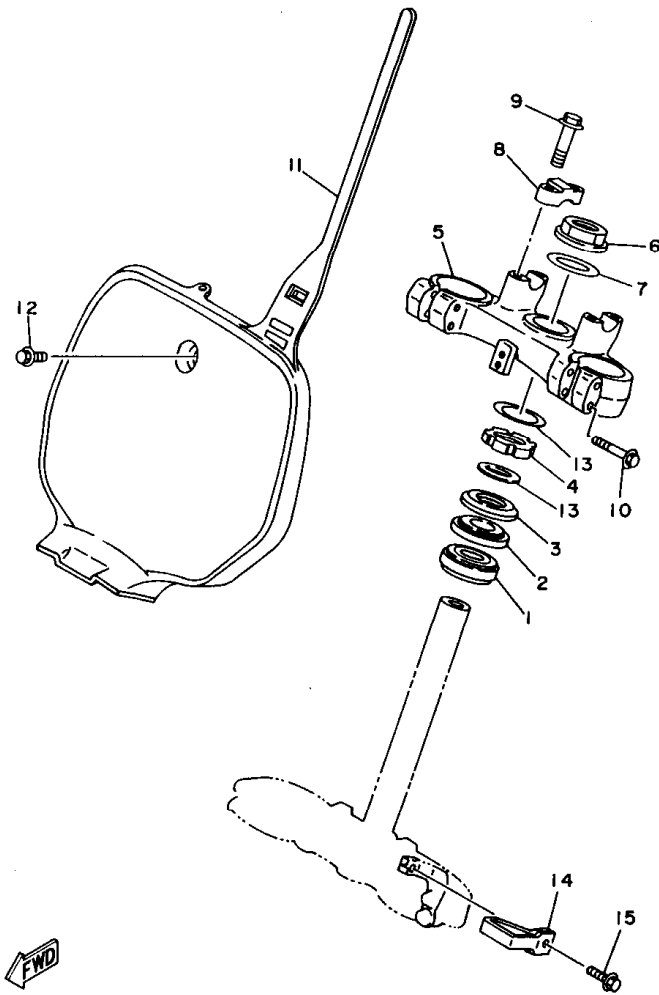

FIG. 20 REAR SUSPENSION

REF. NO.	PART NO.	DESCRIPTION	Q'TY	REMARKS
1	4JW-22210-50	SHOCK ABSORBER ASSY, REAR	1	UR
	4JW-22210-60	SHOCK ABSORBER ASSY, REAR	1	UR FOR CANADA
	4JW-22210-20	SHOCK ABSORBER ASSY, REAR	1	UR FOR JAPAN
	4JW-22210-40	SHOCK ABSORBER ASSY, REAR	1	UR FOR EUROPE/OCEANIA
2	4JW-22201-50	.DAMPER SUB ASSY	1	UR
	4JW-22201-60	.DAMPER SUB ASSY	1	UR FOR CANADA
	4JY-22201-20	.DAMPER SUB ASSY	1	UR FOR JAPAN
	4JW-22201-40	.DAMPER SUB ASSY	1	UR FOR EUROPE/OCEANIA
3	3SP-22234-00	..GUIDE, SPRING 3	1	
4	3SP-22213-00	..SEAT, SPRING UPPER	1	
5	24M-23184-00	..CAP, AIR VALVE	1	
6	4MX-22216-00	..BUSH, REAR SHOCK ABSORBER	1	
7	43M-22274-00	..RING, STOP	1	
8	3Y6-23183-00	..CIRCLIP	1	
9	4JX-22226-00	..BUSH, SHOCK ABSORBER LOWER	1	
10	4JW-22212-00	.SPRING (K=5.0)	1	
11	3JD-22214-00	.GUIDE, SPRING 1	1	
12	3JD-22224-00	.GUIDE, SPRING 2	1	
13	3JD-22475-00	.SEAL, DUST	2	
14	3XJ-22253-00	.COLLAR, DISTANCE	2	
15	3JE-22475-00	.SEAL, DUST	2	
16	4EW-22253-00	.COLLAR, DISTANCE	2	
17	4EW-22474-00	.SEAL, RING	2	
18	3SP-22241-00	BOLT 1	1	
19	95617-10200	NUT, SELF-LOCKING	1	
20	90105-10614	BOLT, WASHER BASED	1	

C13



4JX1100-4210

FIG. 21 STEERING

REF. NO.	PART NO.	DESCRIPTION	Q'TY	REMARKS
1	93332-00078	BEARING	1	
2	93332-00068	BEARING	1	
3	4EW-23416-00	COVER, BALL RACE 2	1	
4	90179-28650	NUT	1	
5	4JX-23435-00	CROWN, HANDLE	1	
6	90170-24373	NUT	1	
7	90201-247L2	WASHER, PLATE	1	
8	3SP-23441-00	HOLDER, HANDLE UPPER	2	
9	95027-08035	BOLT, FLANGE	4	
10	95027-08040	BOLT, FLANGE	4	
11	4DA-23485-01	PLATE, NUMBER	1	
12	90119-06185	BOLT, WITH WASHER	1	
13	90201-286K9	WASHER, PLATE	2	
14	4DA-23389-00	GUIDE, CABLE	1	
15	90105-05361	BOLT, WASHER BASED	1	

C14

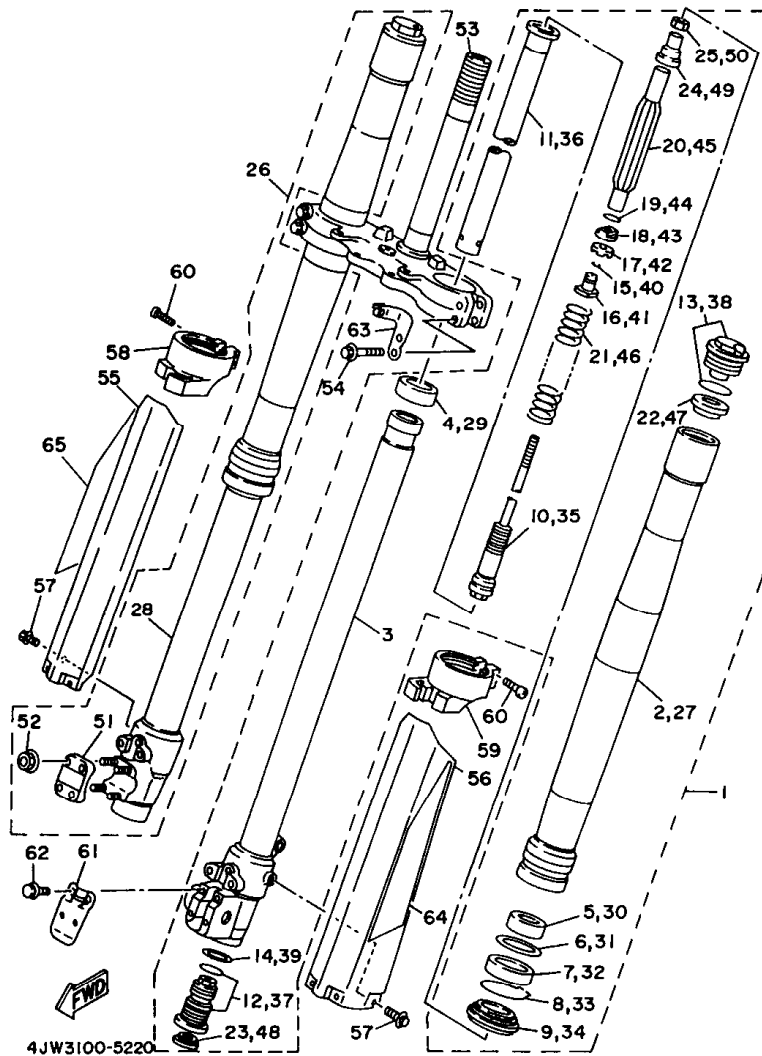

FIG. 22 FRONT FORK

REF. NO.	PART NO.	DESCRIPTION	Q'TY	REMARKS
1	4JW-23102-20	FRONT FORK ASSY (L.H)	1	UR
	4JW-23102-10	FRONT FORK ASSY (L.H)	1	UR FOR EUROPE/OCEANIA/JAPAN
2	4JX-23136-L0	.TUBE, OUTER (RIGHT)	1	
3	4EW-23120-L0	.INNER TUBE COMP. 2	1	
4	3XJ-23171-L0	.PISTON, FRONT FORK	1	
5	4EW-23125-L0	.METAL, SLIDE 1	1	
6	4V4-23146-L0	.WASHER, OIL SEAL	1	
7	3XJ-23145-L0	.OIL SEAL	1	
8	4V4-23153-L0	.RING, SNAP	1	
9	4DA-23144-L0	.SEAL, DUST	1	
10	4JW-2314A-10	.PISTON ROD ASSY	1	UR
	4JX-2314A-M0	.PISTON ROD ASSY	1	UR FOR EUROPE/OCEANIA/JAPAN
11	4JX-23170-L0	.CYLINDER COMP., FRONT FORK	1	
12	4JY-2316A-L0	.VALVE COMP.	1	UR
	4JW-2316A-10	.VALVE COMP.	1	UR FOR EUROPE/OCEANIA/JAPAN
13	4EW-23111-L0	.BOLT, CAP	1	
14	3JD-23158-L0	.GASKET	1	
15	3SP-23153-L0	.RING, SNAP	2	
16	3SP-23113-L0	.COLLAR	1	
17	3SP-23166-L0	.SPACER, OIL LOCK	1	
18	3SP-23393-L0	.NUT, SPECIAL	1	
19	3JD-23147-L0	.O-RING	1	
20	4JX-23142-L0	.SEAT, SPRING UPPER	1	
21	4JW-23141-00	.SPRING, FRONT FORK (K=0.420)	1	UR
	4JX-23141-M0	.SPRING, FRONT FORK (K=0.400)	1	UR FOR EUROPE/OCEANIA/JAPAN
22	3XJ-23143-L0	.SEAT, SPRING LOWER	1	
23	3JD-23126-L0	.PLUG	1	
24	4JX-23363-L0	.COLLAR 1	1	

C15

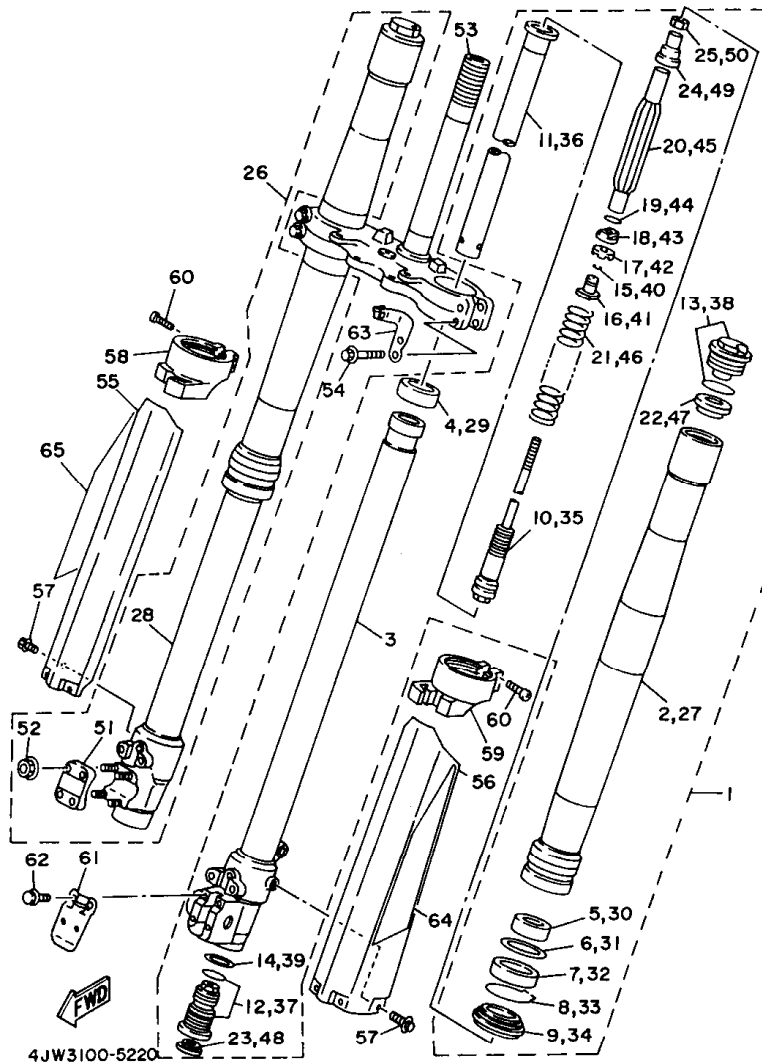

FIG. 22 FRONT FORK

REF. NO.	PART NO.	DESCRIPTION	Q'TY	REMARKS
25	3SP-23357-L0	.NUT	1	
26	4JW-23103-20	FRONT FORK ASSY (R.H)	1	UR
	4JW-23103-10	FRONT FORK ASSY (R.H)	1	UR FOR EUROPE/OCEANIA/JAPAN
27	4JX-23136-L0	.TUBE, OUTER (RIGHT)	1	
28	4EW-23110-L0	.INNER TUBE COMP. 1	1	
29	3XJ-23171-L0	.PISTON, FRONT FORK	1	
30	4EW-23125-L0	.METAL, SLIDE 1	1	
31	4V4-23146-L0	.WASHER, OIL SEAL	1	
32	3XJ-23145-L0	.OIL SEAL	1	
33	4V4-23153-L0	.RING, SNAP	1	
34	4DA-23144-L0	.SEAL, DUST	1	
35	4JW-2314A-10	.PISTON ROD ASSY	1	UR
	4JX-2314A-M0	.PISTON ROD ASSY	1	UR FOR EUROPE/OCEANIA/JAPAN
36	4JX-23170-L0	.CYLINDER COMP., FRONT FORK	1	
37	4JY-2316A-L0	.VALVE COMP.	1	UR
	4JW-2316A-10	.VALVE COMP.	1	UR FOR EUROPE/OCEANIA/JAPAN
38	4EW-23111-L0	.BOLT, CAP	1	
39	3JD-23158-L0	.GASKET	1	
40	3SP-23153-L0	.RING, SNAP	2	
41	3SP-23113-L0	.COLLAR	1	
42	3SP-23166-L0	.SPACER, OIL LOCK	1	
43	3SP-23393-L0	.NUT, SPECIAL	1	
44	3JD-23147-L0	.O-RING	1	
45	4JX-23142-L0	.SEAT, SPRING UPPER	1	
46	4JW-23141-00	.SPRING, FRONT FORK (K=0.420)	1	UR
	4JX-23141-M0	.SPRING, FRONT FORK (K=0.400)	1	UR FOR EUROPE/OCEANIA/JAPAN
47	3XJ-23143-L0	.SEAT, SPRING LOWER	1	
48	3JD-2312G-L0	.PLUG	1	

D2

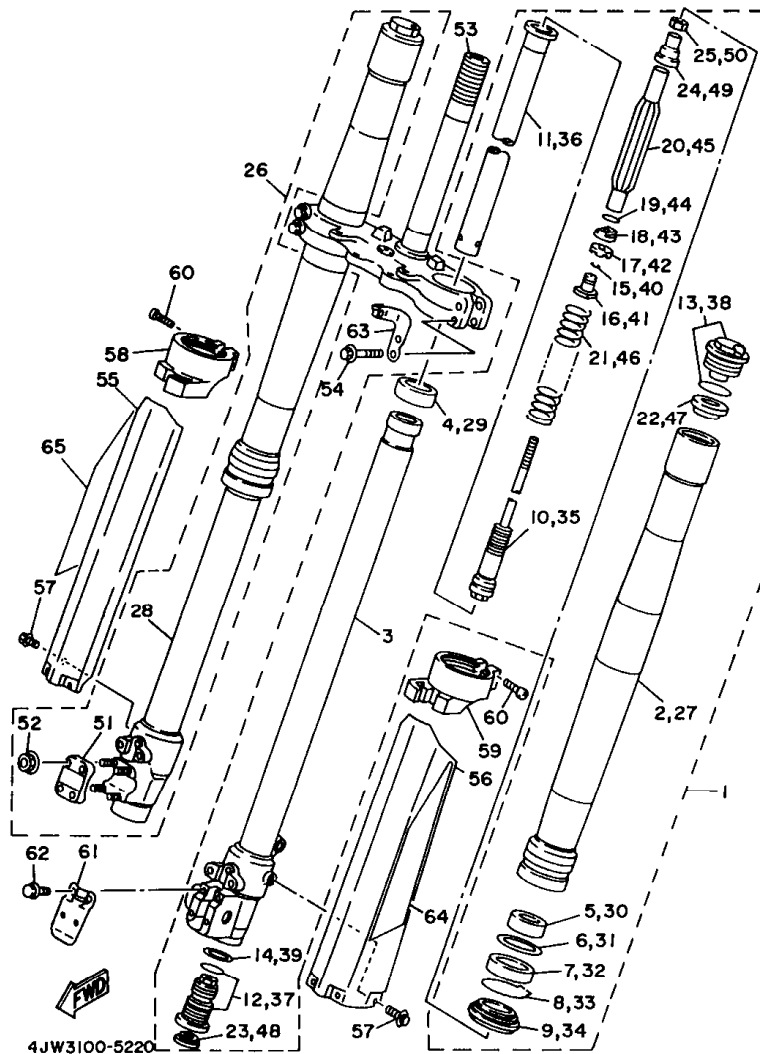
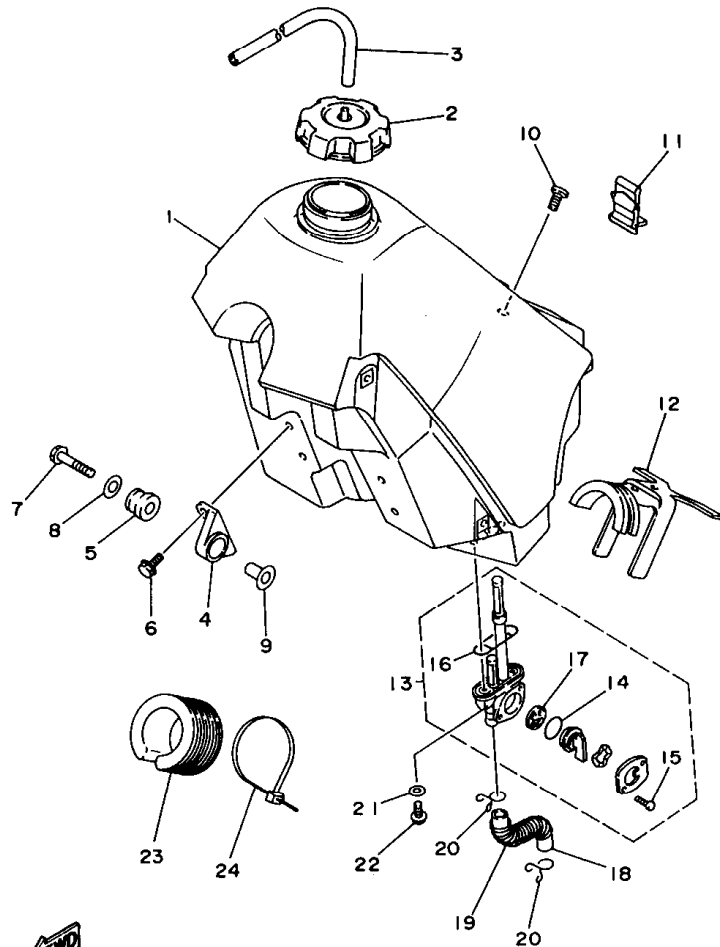

FIG. 22 FRONT FORK

REF. NO.	PART NO.	DESCRIPTION	Q'TY	REMARKS
49	4JX-23363-LO	.COLLAR 1	1	
50	3SP-23357-LO	.NUT	1	
51	4EW-23167-LO	.HOLDER, AXLE	1	
52	2KF-23127-01	.NUT, OUTER TUBE	4	
53	4JX-23340-LO	UNDER BRACKET COMP.	1	
54	95024-08040	BOLT, FLANGE	4	
55	4MX-2314J-LO	PROTECTOR COMP., 2	1	
56	4MX-2314H-L1	PROTECTOR COMP., 1	1	
57	3SP-23356-LO	BOLT 2	6	
58	4MX-2314G-LO	PROTECTOR GUIDE COMP., 2	1	
59	4MX-2314F-LO	PROTECTOR GUIDE COMP., 1	1	
60	4V4-23194-LO	SCREW, BOOT BAND	4	
61	4EW-2314E-LO	COVER, HOSE	1	
62	4DA-23346-LO	BOLT 1	4	
63	4EW-2331E-LO	GUIDE, CABLE	1	
64	4JW-2313B-11	EMBLEM1	1	
65	4JW-2313C-11	EMBLEM2	1	

D3



4JW1100-4230

FIG. 23 FUEL TANK

REF. NO.	PART NO.	DESCRIPTION	Q'TY	REMARKS
1	4JW-24110-00	FUEL TANK COMP.	1	
2	111Y-24610-00	CAP ASSY	1	
3	90445-09252	HOSE	1	
4	24X-24144-00	HOLDER, DAMPER	2	
5	90480-18549	GROMMET	2	
6	95027-06016	BOLT, FLANGE	4	
7	95027-06035	BOLT, FLANGE	2	
8	90201-06697	WASHER, PLATE	2	
9	3JD-24186-00	WASHER, SPECIAL	2	
10	98907-06020	SCREW, BIND	1	
11	3SP-24173-00	BAND, TANK FITTING 1	1	
12	4EW-24181-00	DAMPER, LOCATING 1	1	
13	4JW-24500-00	FUEL COCK ASSY 1	1	
14	3AJ-24534-00	.SEAL, COCK	1	
15	98503-03008	.SCREW, PAN HEAD	2	
16	4X8-24512-00	.O-RING	1	
17	3AJ-24523-00	.VALVE, PACKING	1	
18	4JW-24311-10	PIPE, FUEL 1	1	
19	90501-08364	SPRING, COMPRESSION	1	
20	90467-10008	CLIP	2	
21	90202-05187	WASHER, PLATE	2	
22	90149-06011	SCREW	2	
23	4EW-24182-00	DAMPER, LOCATING 2	1	
24	90464-14117	CLAMP	1	

D4

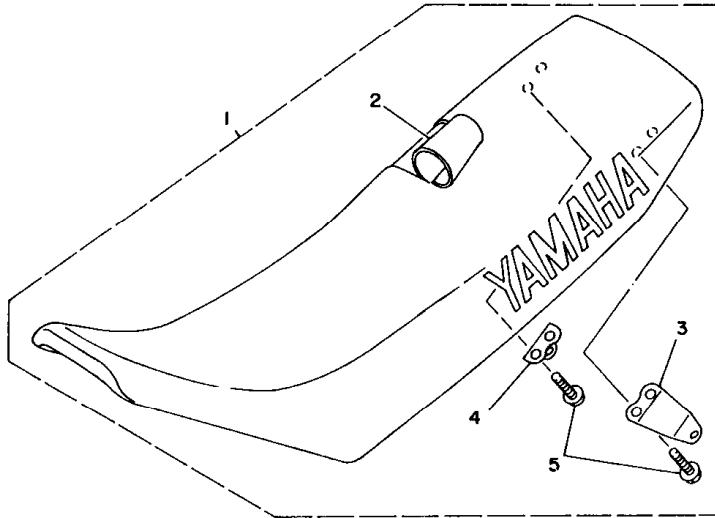

FIG. 24 SEAT

REF. NO.	PART NO.	DESCRIPTION	Q'TY	REMARKS
1	4JW-24770-00	SEMI-DOUBLE SEAT ASSY	1	
2	4JW-24731-00	.COVER, SEAT	1	
3	4EW-24728-00	.BRACKET, SEAT	1	
4	4EW-24738-00	.BRACKET, SEAT	1	
5	95027-06016	.BOLT, FLANGE	4	



4EW1100-324 I

D5

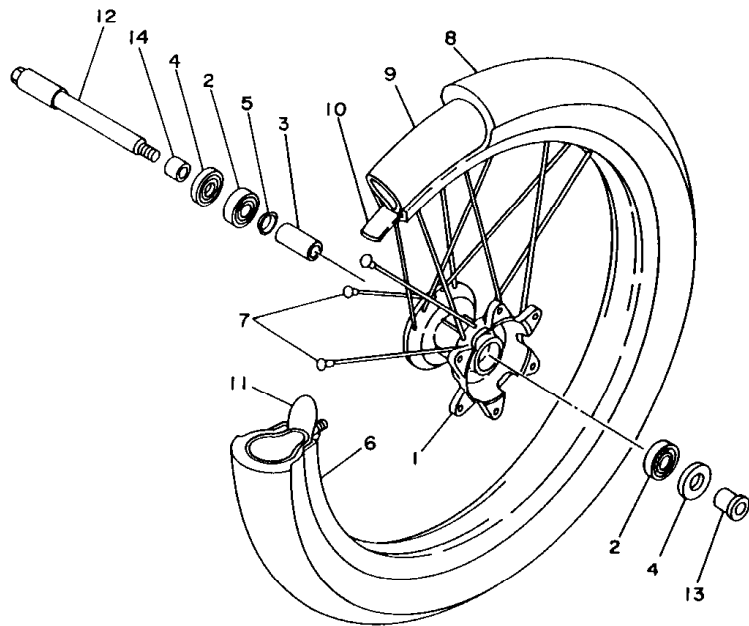

FIG. 25 FRONT WHEEL

REF. NO.	PART NO.	DESCRIPTION	Q'TY	REMARKS
1	4EW-25111-00	HUB, FRONT	1	
2	93306-00316	BEARING	2	
3	90560-17379	SPACER	1	
4	93106-22032	OIL SEAL	2	
5	146-25116-00	FLANGE, SPACER 2	1	
6	94416-21509	RIM (1.60-21)	1	
7	4DA-25104-00	SPOKE SET, FRONT	1	
8	94108-217X8	TIRE (80/100-21-ED11)	1	BRIDGESTONE
9	94209-21277	TUBE (MCS 90/90-21 TR-4)	1	BRIDGESTONE
10	94330-21084	BAND, RIM (3.00-21)	1	BRIDGESTONE
11	5X2-25394-00	SPACER, BEAD	1	
12	4JW-25181-00	AXLE, WHEEL	1	
13	90387-173Y0	COLLAR	1	
14	90387-172Y9	COLLAR	1	



4EW1100-3250

D6

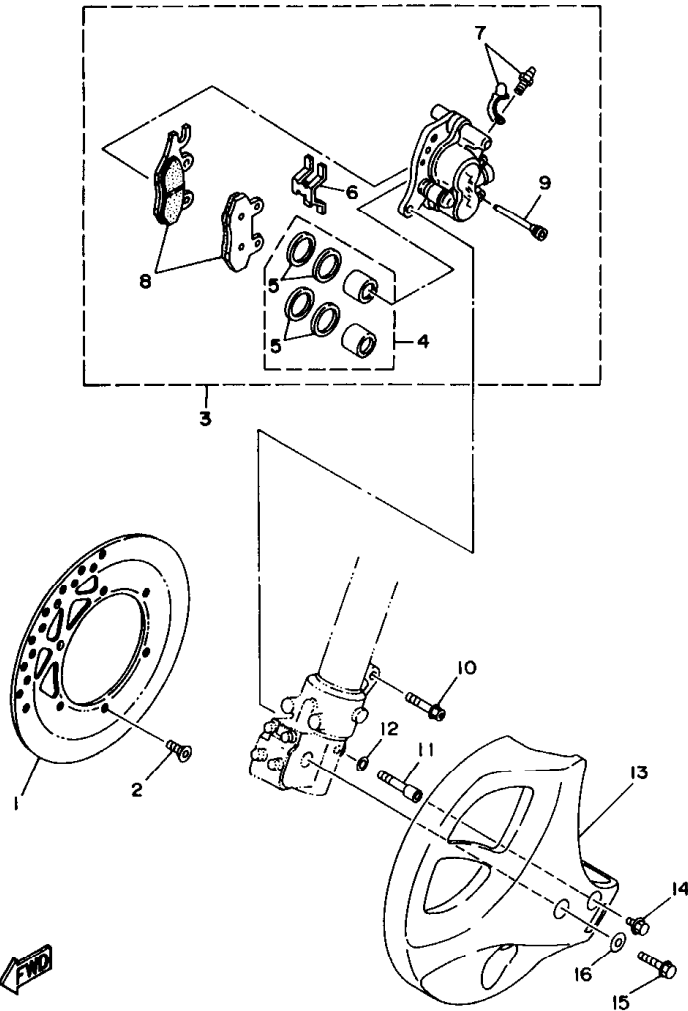
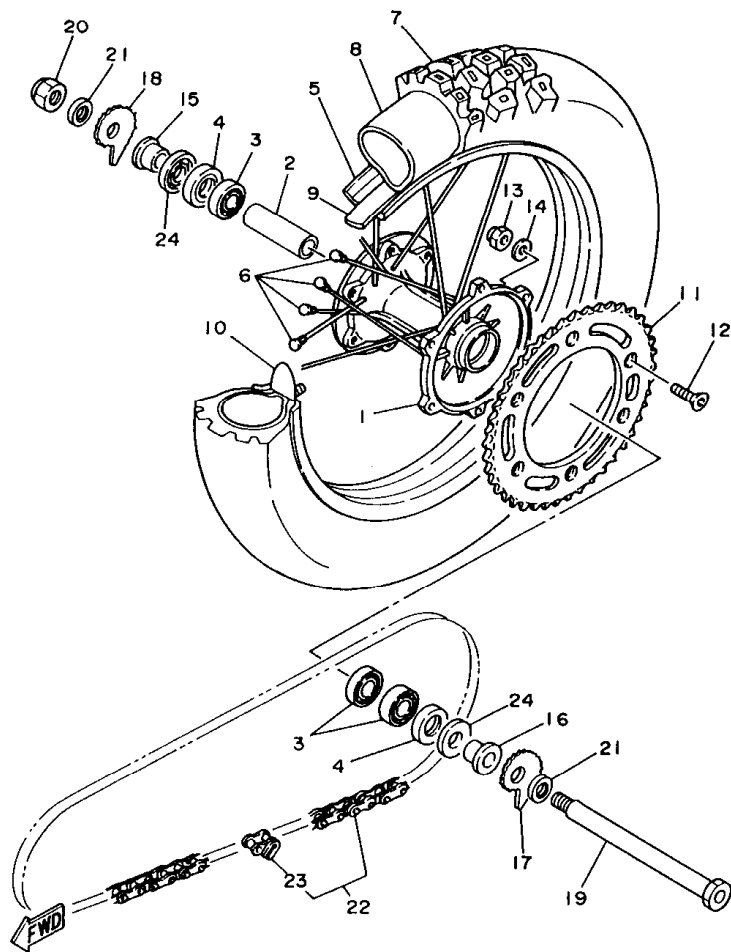

FIG. 26 FRONT BRAKE CALIPER

REF. NO.	PART NO.	DESCRIPTION	Q'TY	REMARKS
1	4JX-2582T-00	DISC, BRAKE	1	
2	90149-06272	SCREW	6	
3	4MX-2580T-00	CALIPER ASSY (LEFT)	1	
4	4EW-W0057-00	.PISTON ASSY, CALIPER	1	
5	3JD-W0047-00	..CALIPER SEAL KIT	1	
6	3SP-25919-01	.SUPPORT, PAD	1	
7	36Y-W0048-00	.BREED SCREW KIT	1	
8	4MX-W0045-00	.BRAKE PAD KIT	1	
9	3GD-25933-00	.PIN, PAD	2	
10	90105-08659	BOLT, WASHER BASED	1	
11	90109-08066	BOLT	1	
12	90201-090J9	WASHER, PLATE	1	
13	4JW-25717-00	PROTECTOR, DISK BRAKE	1	
14	95827-06012	BOLT, FLANGE	1	
15	95027-08035	BOLT, FLANGE	1	
16	92907-08200	WASHER, PLAIN	1	

4JW1100-4260

D7



4JW3100-5270

FIG. 27 REAR WHEEL

REF. NO.	PART NO.	DESCRIPTION	Q'TY	REMARKS
1	4EW-25311-00	HUB, REAR	1	
2	4EW-25317-00	SPACER, BEARING	1	
3	93306-00418	BEARING	3	
4	93106-28023	OIL SEAL	2	
5	94421-18498	RIM (2.15-18)	1	
6	2VN-25304-00	SPOKE SET, REAR	1	
7	94111-187X9	TIRE (110/100-18-ED12)	1	BRIDGESTONE
8	94213-18232	TUBE (MC130/80-18)	1	BRIDGESTONE
9	94340-18086	BAND, RIM (4.00-18)	1	BRIDGESTONE
10	39X-25394-00	SPACER, BEAD	2	
11	26A-25452-50	SPROCKET, DRIVEN (52T)	1	STD
	26A-25444-50	SPROCKET, DRIVEN (44T)	1	AP
	26A-25446-50	SPROCKET, DRIVEN (46T)	1	AP
	26A-25448-50	SPROCKET, DRIVEN (48T)	1	AP
	26A-25450-50	SPROCKET, DRIVEN (50T)	1	AP
12	90109-081G1	BOLT	6	
13	95617-08100	NUT, U	6	
14	90201-086P8	WASHER, PLATE	6	
15	90387-2000B	COLLAR	1	
16	90387-2000C	COLLAR	1	
17	3BN-25388-00	PULLER, CHAIN 1	1	
18	3BN-25389-00	PULLER, CHAIN 2	1	
19	23X-25381-00	AXLE, WHEEL	1	
20	90185-18104	NUT, SELF-LOCKING	1	
21	90201-206R3	WASHER, PLATE	2	
22	9Y581-08115	CHAIN (D.I.D 520V6-116L)	1	
23	94681-08011	.JOINT, CHAIN (D.I.D 520V6-FJ)	1	
24	4V4-25367-00	COVER, HUB DUST	2	

D8

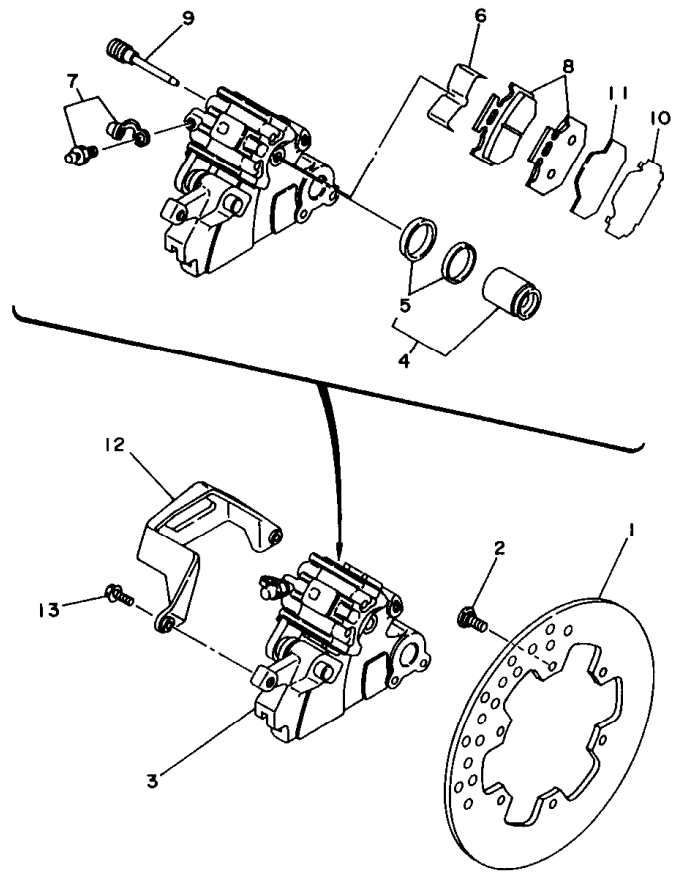

FIG. 28 REAR BRAKE CALIPER

REF. NO.	PART NO.	DESCRIPTION	Q'TY	REMARKS
1	4JX-2582W-00	DISC, REAR BRAKE 2	1	
2	90149-06272	SCREW	6	
3	4GY-2580W-00	CALIPER ASSY, REAR 2	1	
4	3SP-W0057-50	.PISTON ASSY, CALIPER	1	
5	3JD-W0047-50	..CALIPER SEAL KIT	1	
6	4GY-25919-50	.SUPPORT, PAD	1	
7	36Y-W0048-00	.BREED SCREW KIT	1	
8	4GY-W0046-00	.BRAKE PAD KIT 2	1	
9	3SP-25924-51	.PIN, PAD	2	
10	4GY-25827-50	.SHIM, CALIPER	1	
11	4GY-22898-50	.INSULATOR, HEAT	1	
12	4GY-27491-00	PROTECTOR	1	
13	95027-06016	BOLT, FLANGE	2	



4JX1100-4281

D9

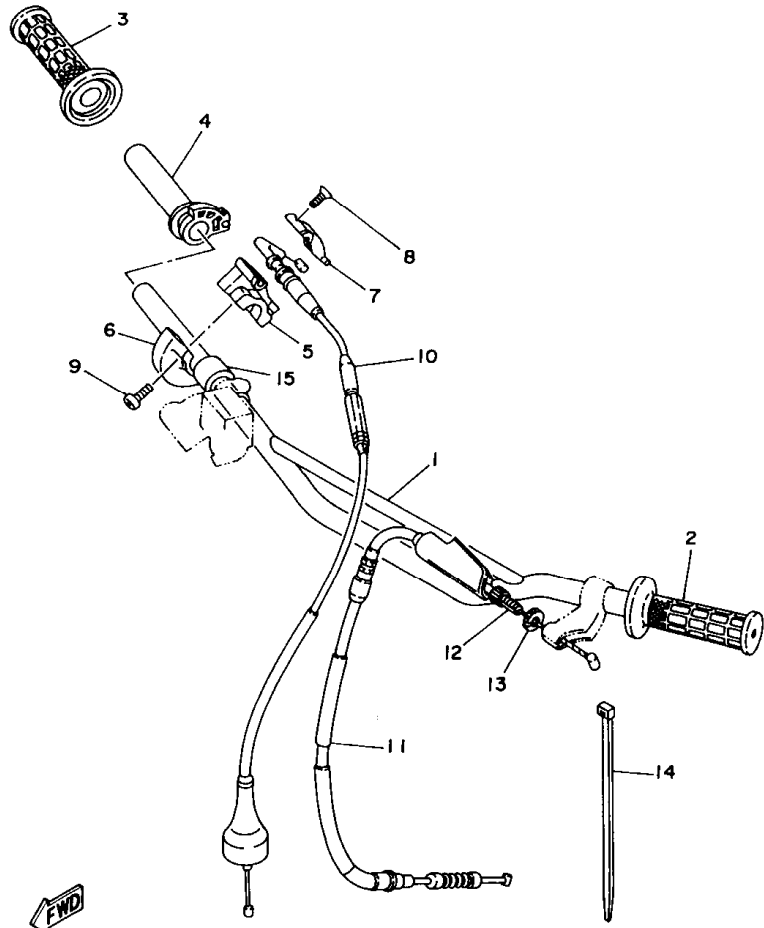

4DC1100-2290

FIG. 29 STEERING HANDLE. CABLE

REF. NO.	PART NO.	DESCRIPTION	Q'TY	REMARKS
1	4JX-26111-00	HANDLEBAR	1	
2	1LX-26241-01	GRIP (LEFT)	1	
3	1LX-26242-01	GRIP (RIGHT)	1	
4	23X-26243-00	TUBE, THROTTLE GUIDE	1	
5	23X-26281-00	CAP, GRIP UPPER	1	
6	431-26282-02	CAP, GRIP LOWER	1	
7	5X2-2628H-01	CAP, WIRE	1	
8	98707-04012	SCREW, FLAT HEAD	2	
9	98507-05016	SCREW, PAN HEAD	2	
10	4AA-26311-00	CABLE, THROTTLE 1	1	
11	4EW-26335-00	CABLE, CLUTCH	1	
12	90123-08090	BOLT	1	
13	90179-08401	NUT	1	
14	90464-14117	CLAMP	1	
15	90560-22281	SPACER	1	

D10

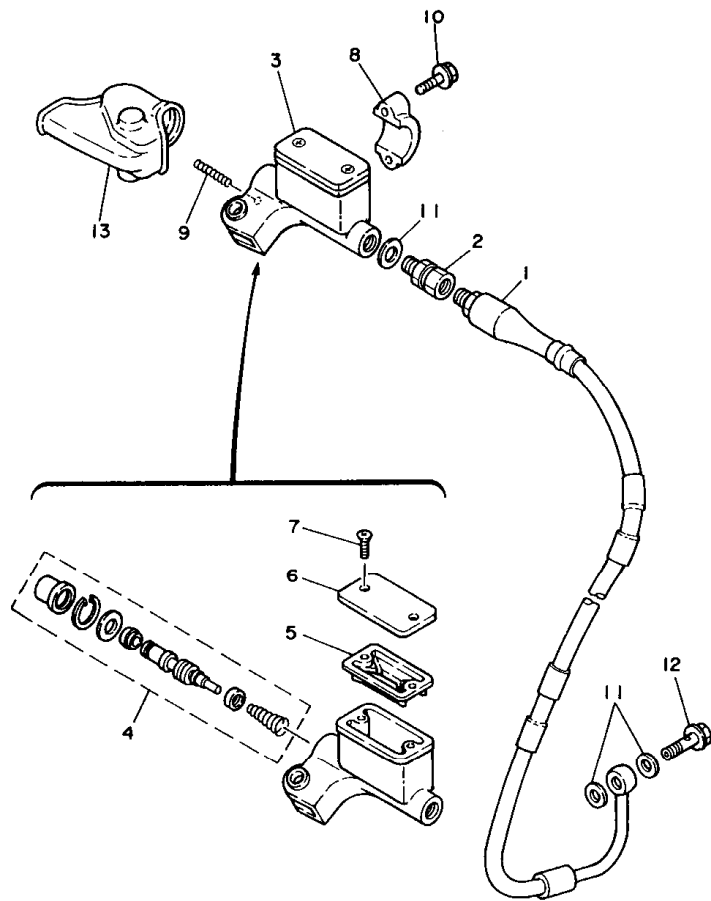

FIG. 30 FRONT MASTER CYLINDER

REF. NO.	PART NO.	DESCRIPTION	Q'TY	REMARKS
1	4MX-25872-00	HOSE, BRAKE 1	1	
2	3LC-25885-00	JOINT	1	
3	3SP-25870-01	MASTER CYLINDER SUB ASSY	1	
4	3SP-W0041-00	.CYLINDER KIT, MASTER	1	
5	56A-25854-00	.DIAPHRAGM, RESERVOIR	1	
6	2VN-25852-01	.CAP, RESERVOIR	1	
7	98707-04012	.SCREW, FLAT HEAD	2	
8	56A-25867-00	BRACKET, MASTER CYLINDER	1	
9	90501-061G2	SPRING, COMPRESSION	1	
10	95027-06025	BOLT, FLANGE	2	
11	90201-10118	WASHER, PLATE	3	
12	90401-10159	BOLT, UNION	1	
13	56A-26372-01	COVER, HANDLE LEVER 1	1	



3SP1100-0300

D11

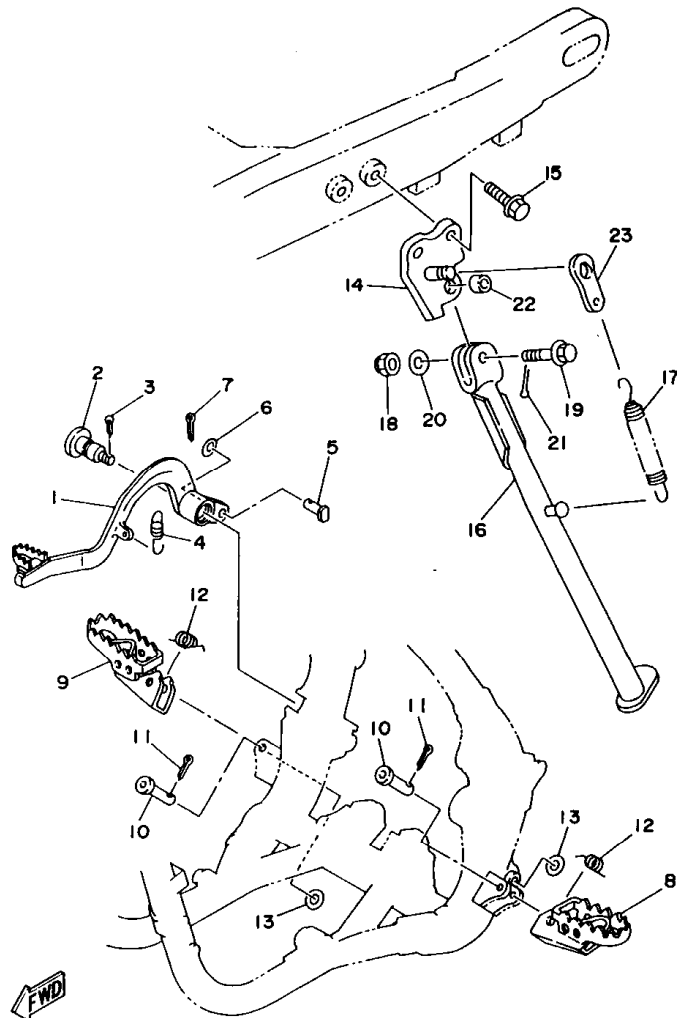

4DC1100-2310

FIG. 31 STAND, FOOTREST

REF. NO.	PART NO.	DESCRIPTION	Q'TY	REMARKS
1	4JX-27200-00	PEDAL, BRAKE	1	
2	4JX-27217-00	BOLT	1	
3	91490-20020	PIN, COTTER	1	
4	90506-15480	SPRING, TENSION	1	
5	90240-08120	PIN, CLEVIS	1	
6	92901-08600	WASHER, PLATE	1	
7	91401-25020	PIN, COTTER	1	
8	4DA-27411-00	FOOTREST 1	1	
9	4DA-27421-00	FOOTREST 2	1	
10	90240-10117	PIN, CLEVIS	2	
11	91401-25020	PIN, COTTER	2	
12	90508-28777	SPRING, TORSION	2	
13	90201-10119	WASHER, PLATE	2	
14	4JW-27321-00-T9	BRACKET, SIDE STAND	1	COMPETITION SILVER
15	90105-10666	BOLT, WASHER BASED	2	
16	4JW-27311-00	STAND, SIDE	1	
17	90507-32059	SPRING, TENSION	1	
18	90185-10120	NUT, SELF-LOCKING	1	
19	90105-10549	BOLT, WASHER BASED	1	
20	92990-10200	WASHER, PLAIN	1	
21	91401-25020	PIN, COTTER	1	
22	90387-1003G	COLLAR	1	
23	4AA-27263-00	BRACKET 1	1	

D12

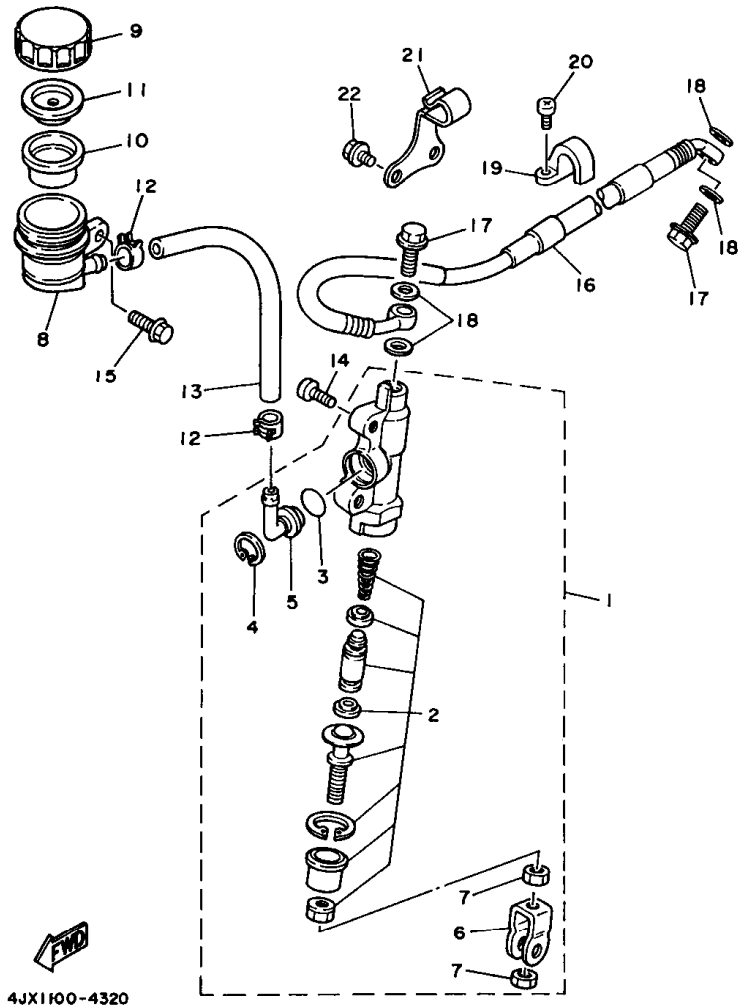

4JX1100-4320

FIG. 32 REAR MASTER CYLINDER

REF. NO.	PART NO.	DESCRIPTION	Q'TY	REMARKS
1	3SP-2583V-00	RR. MASTER CYLINDER ASSY	1	
2	1FK-W0042-50	.CYLINDER KIT, MASTER	1	
3	93210-15620	.O-RING	1	
4	2VN-25866-00	.CIRCLIP	1	
5	2VN-2582A-50	.JOINT	1	
6	3SP-27222-00	.JOINT	1	
7	95333-08600	.NUT	2	
8	4EW-25894-00	TANK, RESERVOIR	1	
9	3XP-25852-50	CAP, RESERVOIR	1	
10	2VN-25854-00	DIAPHRAGM, RESERVOIR	1	
11	2VN-25855-00	BUSH, DIAPHRAGM	1	
12	90467-11044	CLIP	2	
13	90445-137H9	HOSE	1	
14	92014-06016	BOLT, BUTTON HEAD	2	
15	95027-06012	BOLT, FLANGE	1	
16	4JX-25873-00	HOSE, BRAKE 2	1	
17	90401-10159	BOLT, UNION	2	
18	90201-10118	WASHER, PLATE	4	
19	2VM-25876-00	HOLDER, BRAKE HOSE 2	1	
20	97780-50110	SCREW, TAPPING	2	
21	90465-12362	CLAMP	1	
22	95027-06008	BOLT, FLANGE	2	

D13

FIG. 33 GENERATOR

REF. NO.	PART NO.	DESCRIPTION	Q'TY	REMARKS
1	3SP-85550-10	ROTOR ASSY	1	
2	3RB-85560-11	BASE ASSY	1	
3	90149-06011	SCREW	2	
4	90179-10394	NUT	1	
5	90201-10774	WASHER, PLATE	1	

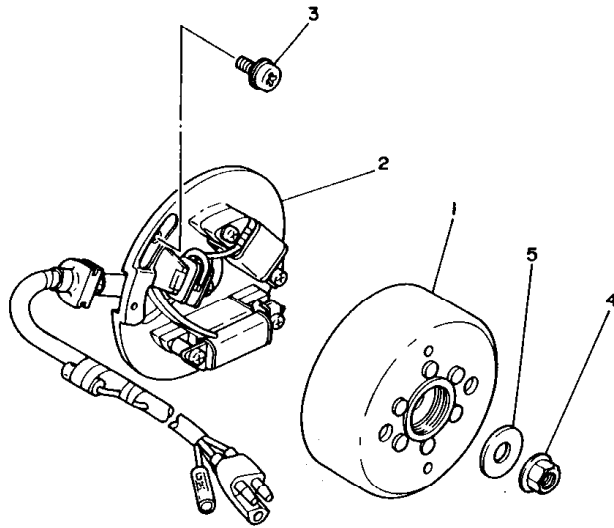

3RB2100-0330

D14

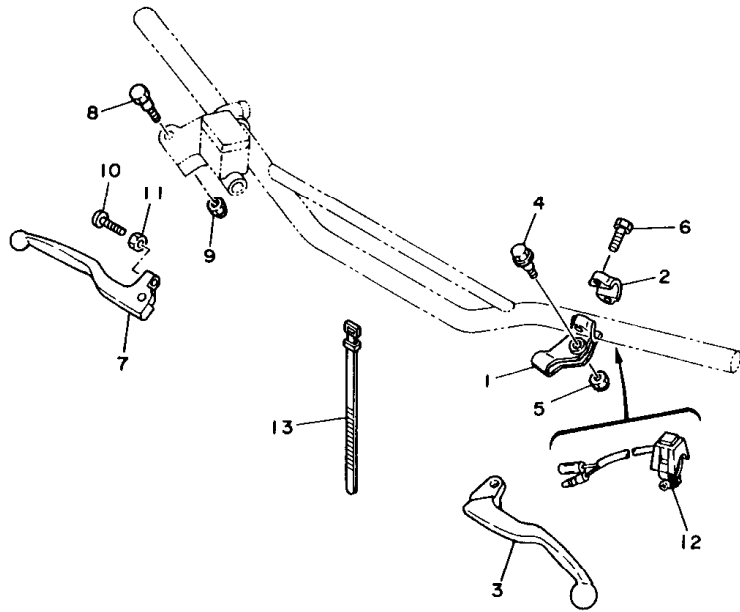

FIG. 34 HANDLE SWITCH. LEVER

REF. NO.	PART NO.	DESCRIPTION	Q'TY	REMARKS
1	38V-82911-00	HOLDER, LEVER 1	1	
2	38V-82913-00	HOLDER, LEVER LOWER 1	1	
3	4GY-83912-00	LEVER 1	1	
4	90109-06799	BOLT	1	
5	95607-06100	NUT, U	1	
6	97007-05016	BOLT	2	
7	3SP-83922-00	LEVER 2	1	
8	90109-06577	BOLT	1	
9	95607-06100	NUT, U	1	
10	90143-06024	SCREW, HEXAGON	1	
11	90170-06010	NUT	1	
12	23X-83976-00	SWITCH, HANDLE 1	1	
13	437-83936-01	BAND, SWITCH CORD	2	



4JX1100-4340

D15

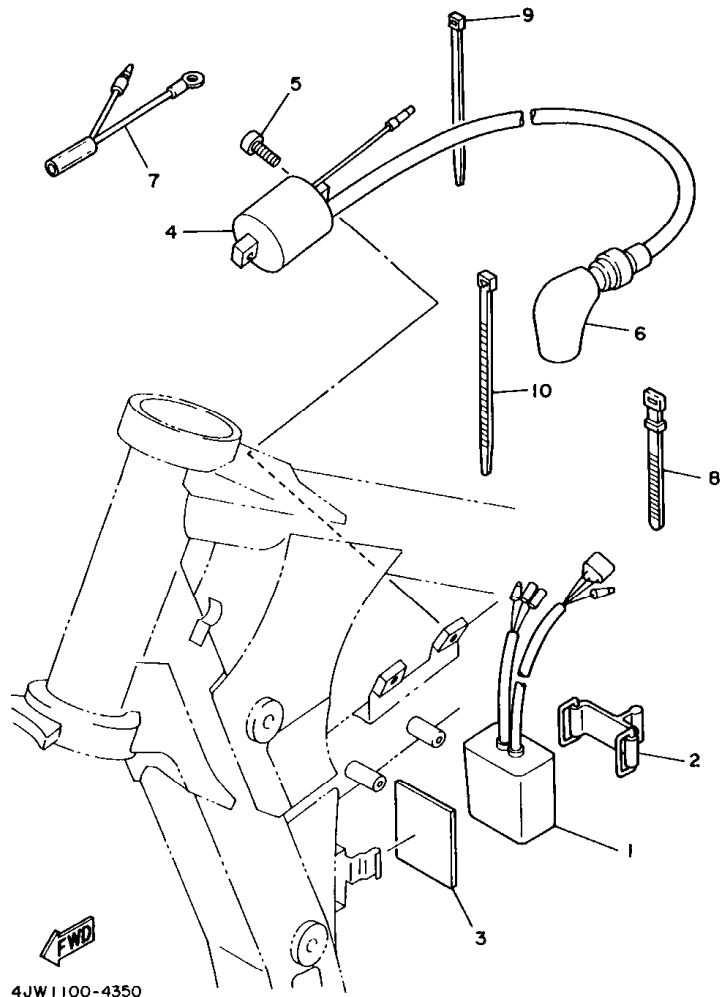
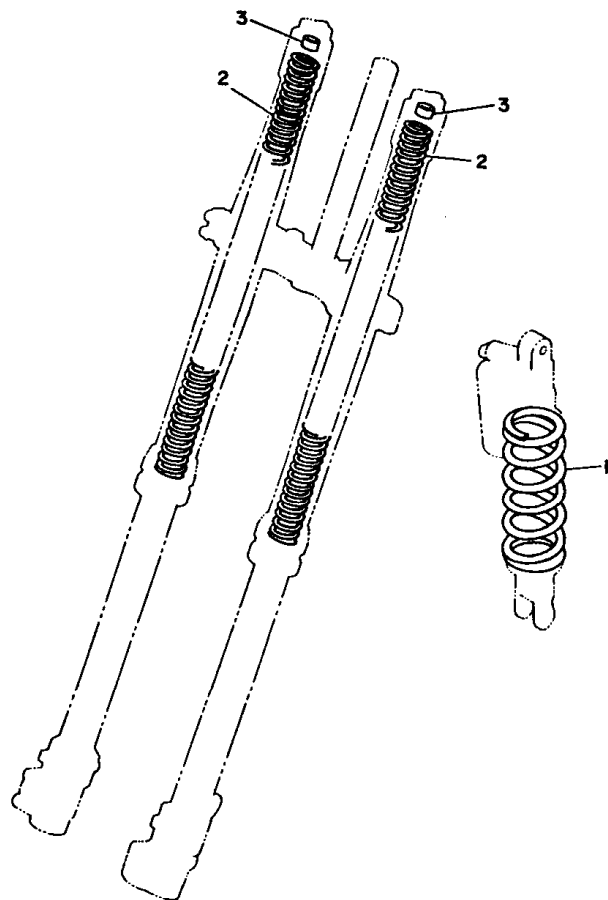

FIG. 35 ELECTRICAL 1

REF. NO.	PART NO.	DESCRIPTION	Q'TY	REMARKS
1	4EW-85540-00	C.D.I. UNIT ASSY	1	
2	5H9-21376-00	BAND, TOOL	1	
3	3RB-85547-01	DAMPER	1	
4	4JX-82310-00	IGNITION COIL ASSY	1	
5	91317-06016	BOLT	2	
6	81E-82370-20	PLUG CAP ASSY	1	
7	5X1-82519-01	WIRE, EARTH LEAD	1	
8	25G-83936-01	BAND, SWITCH CORD	1	
9	12R-82591-00	BAND	1	
10	1UA-82591-00	BAND	1	

E2

ALTERNATE PARTS



3XJ1100-1360

FIG. 36 ALTERNATE (CHASSIS)

REF. NO.	PART NO.	DESCRIPTION	Q'TY	REMARKS
1	4JX-22212-10	SPRING (K=4.4)	1	AP
	4JX-22212-20	SPRING (K=4.6)	1	AP
	4JX-22212-30	SPRING (K=4.8)	1	AP
	4JX-22212-40	SPRING (K=5.0)	1	AP
	4JX-22212-50	SPRING (K=5.2)	1	AP
	4JX-22212-60	SPRING (K=5.4)	1	AP
2	3XJ-23141-10	SPRING, FRONT FORK (K=0.350)	2	AP
	3XJ-23141-LO	SPRING, FRONT FORK (K=0.365)	2	AP
	3XJ-23141-30	SPRING, FRONT FORK (K=0.380)	2	AP
	3XK-23141-LO	SPRING, FRONT FORK (K=0.390)	2	AP
	3XJ-23141-50	SPRING, FRONT FORK (K=0.400)	2	AP
	3XK-23141-MO	SPRING, FRONT FORK (K=0.410)	2	AP
	3XJ-23141-70	SPRING, FRONT FORK (K=0.420)	2	AP
	3XJ-23141-80	SPRING, FRONT FORK (K=0.430)	2	AP
3	3XJ-23364-LO	COLLAR 2	1	UN

E3

REPAIR KIT

FIG. 37 REPAIR KIT

REF. NO.	PART NO.	DESCRIPTION	Q'TY	REMARKS
1	4JX-11630-00	PISTON ASSY (STD)	1	
2	4EW-11631-01-B0	.PISTON (STD)	1	ORANGE
3	4JX-11603-00	.PISTON RING SET (STD)	1	
4	2VM-11633-01	.PIN, PISTON	1	
5	93450-19052	.CIRCLIP	2	
6	4JX-11650-00	CONNECTING ROD ASSY	1	
7	5X5-11651-03	.ROD, CONNECTING	1	
8	3JE-11681-01	.PIN, CRANK 1	1	
9	90209-25085	.WASHER	2	
10	93310-425P2	.BEARING, CYLINDRICAL	1	
11	93310-418E9	.BEARING, CYLINDRICAL	1	

E4

INDEX

NUMERICAL INDEX

PART NO.	GRID NO.	PART NO.	GRID NO.	PART NO.	GRID NO.	PART NO.	GRID NO.	PART NO.	GRID NO.	PART NO.	GRID NO.
3SP-W0041-00	D-11	3SP-11993-10	B- 3	5Y9-14158-00	B- 9	4EW-16356-00	B-15	4JW-2173E-11	C- 9	4JW-23102-10	C-15
1FK-W0042-50	D-13	2VM-11995-00	B- 3	1W3-14175-00	B-10	4EW-16357-00	B-15	4JW-2173F-11	C- 9	4JW-23102-20	C-15
4MX-W0045-00	D- 7	4EW-1240A-01	B- 7	363-14184-00	B- 9	4EW-16371-01	B-15	4JW-2173G-11	C- 9	4JW-23103-10	D- 2
4GY-W0046-00	D- 9	3SP-12422-00	B- 6	2N7-14185-00	B- 9	4EW-16381-01	B-15	4EW-21731-00	C- 9	4JW-23103-20	D- 2
3JD-W0047-00	D- 7	2VM-12428-10	B- 6	537-14186-00	B- 9	2VM-17121-01	C- 2	4EW-21741-00	C- 9	4EW-23110-L0	D- 2
3JD-W0047-50	D- 9	2VM-12450-00	B- 6	2HH-14197-00	B- 9	3RB-17131-00	C- 2	3JD-21748-00	C- 8	4EW-23111-L0	C-15
36Y-W0048-00	D- 7	2VM-12459-00	B- 6	510-14197-00	B- 9	3RB-17141-10	C- 2	4JW-21783-11	C- 9		D- 2
	D- 9	4JW-12461-00	B- 7	4JW-14411-01	B- 8	3RB-17151-00	C- 2	4JW-22110-00	C-11	3SP-23113-L0	C-15
3SP-W0057-50	D- 9	22W-12462-00	B- 7	4PE-14451-00	B- 8	3RB-17211-00	C- 2	156-22127-00	C-11		D- 2
4EW-W0057-00	D- 7	10V-12469-01	B- 6	4JW-14453-00	B- 8	2VM-17221-00	C- 2	4MX-22128-00	C-11	3JD-2312G-L0	C-15
3JE-Y113E-00	B- 2	24X-12469-00	B- 7	3JD-14458-00	B- 8	3RB-17231-00	C- 2	4EW-22129-00	C-11		D- 2
5X4-Y113F-10	B- 2	4JW-12476-00	B- 7	3JD-14459-00	B- 8	3RB-17241-10	C- 2	1LX-22141-00	C-11	4EW-23120-L0	C-15
3SP-Y1543-00	B-13	4EW-12477-00	B- 7	3JD-14462-00	B- 8	3RB-17251-00	C- 2	4EW-22151-01	C-11	4EW-23125-L0	C-15
4EW-11111-00	B- 2	4JW-1248A-00	B- 7	3JD-14477-00	B- 8	4JW-17411-00	C- 2	4EW-2217A-00	C-11		D- 2
4JX-1131A-00	B- 2	4JW-12482-00	B- 7	4EW-14610-02	B-11	2VM-17421-01	C- 2	4EW-2217F-00	C-12	2XF-23127-01	D- 3
3JE-1131N-10	B- 2	4JW-12483-00	B- 7	3R4-14613-00	B-11	4L0-17471-00	B-12	3JD-22178-10	C- 6	4JW-2313B-11	D- 3
4JX-11311-00	B- 2	4JW-12485-00	B- 7	3JE-14615-01	B-11	3XK-18101-01	C- 5	4EW-22178-00	C- 6	4JW-2313C-11	D- 3
2VM-11351-10	B- 2	353-13115-01	B-12	4EW-1469A-01	B-11	2VM-18110-00	C- 5	4EW-22199-01	C-11	4JX-23136-L0	C-15
4JX-11400-00	B- 5	4DC-13655-00	B- 8	4EW-14753-01	B-11	3XK-18122-00	C- 5	4JW-22201-40	C-13		D- 2
4JX-11412-00	B- 5	4DC-13610-00	B- 8	565-14771-00	B-11	3XK-18140-00	C- 4	4JW-22201-50	C-13	4JW-2314A-10	C-15
4JX-11422-00	B- 5	3SP-13613-00	B- 8	483-14781-02	B-11	4DA-18172-00	C- 5	4JW-22201-60	C-13		D- 2
4JX-11603-00	B- 5	4DA-13616-00	B- 8	23X-1490J-00	B- 9	3XJ-18173-00	C- 5	4JY-22201-20	C-13	4JX-2314A-M0	C-15
	E- 4	2K7-13621-10	B- 8	256-14954-00	B-10	3XK-18177-00	C- 4	4JW-22210-20	C-13		D- 2
4JX-11630-00	E- 4	26A-1410A-00	B-10	2VM-15111-05	B-12	3XJ-18178-00	C- 5	4JW-22210-40	C-13	4EW-2314E-L0	D- 3
4EW-11631-01-A0	B- 5	4JW-14101-10	B- 9	4V4-15118-00	B-12	3XJ-18182-00	C- 5	4JW-22210-50	C-13	4MX-2314F-L0	D- 3
4EW-11631-01-B0	B- 5	23X-14103-00	B- 9	2VM-15121-02	B-12	3XJ-18184-00	C- 5	4JW-22210-60	C-13	4MX-2314G-L0	D- 3
	E- 4	23X-14104-00	B- 9	1G8-15362-00	B-13	4EW-18185-00	C- 5	4JW-22212-00	C-13	4MX-2314H-L1	D- 3
4EW-11631-01-C0	B- 5	23X-14106-00	B- 9	3SP-15381-00	B-12	2VM-18511-00	C- 4	4JX-22212-10	E- 3	4MX-2314J-L0	D- 3
4EW-11631-01-D0	B- 5	23X-14107-35	B- 9	2VM-15411-00	B-13	2VM-18512-00	C- 4	4JX-22212-20	E- 3	3XJ-23141-L0	E- 3
2VM-11633-01	B- 5	2X8-14112-35	B- 9	4EW-15415-00	B-13	2VM-18513-00	C- 4	4JX-22212-30	E- 3	3XJ-23141-10	E- 3
	E- 4	2X8-14112-40	B- 9	2VM-15421-02	B-13	4EX-18531-00	C- 4	4JX-22212-40	E- 3	3XJ-23141-30	E- 3
4JX-11650-00	E- 4	2X8-14112-45	B- 9	2VM-15451-10	B-13	3XV-18535-00	C- 4	4JX-22212-50	E- 3	3XJ-23141-50	E- 3
5X5-11651-03	B- 5	510-14115-00	B- 9	2VM-15462-10	B-13	3XK-18540-01	C- 4	4JX-22212-60	E- 3	3XJ-23141-70	E- 3
	E- 4	431-14131-00	B- 9	3SP-15463-11	B-13	4JX-21101-00-G3	C- 6	3SP-22213-00	C-13	3XJ-23141-80	E- 3
3JE-11681-01	B- 5	510-14141-R0	B- 9	4JW-15620-00	B-14	4JX-21190-01-G3	C- 6	3JD-22214-00	C-13	3XK-23141-L0	E- 3
	E- 4	510-14141-R2	B- 9	3SP-15621-02	B-14	46X-21269-00	C-12	4MX-22216-00	C-13	3XK-23141-M0	E- 3
5X5-11911-01	B- 4	510-14141-R4	B- 9	3R4-15641-00	B-14	5H9-21376-00	E- 2	3JD-22224-00	C-13	4JW-23141-00	C-15
5X5-11912-01	B- 4	193-14142-35	B- 9	38V-15651-00	B-14	4EW-21417-00	C- 6	4JX-22226-00	C-13		D- 2
1LX-11915-00	B- 3	193-14142-40-A1	B- 9	4JW-15660-00	B-14	4EW-21425-00	C- 6	3SP-22234-00	C-13	4JX-23141-M0	C-15
5X4-11921-02	B- 4	193-14142-45-A1	B- 9	2VM-15664-00	B-14	4EW-21427-00	C- 6	3SP-22241-00	C-13		D- 2
3JE-11922-00	B- 4	137-14143-76	B- 9	2VM-16111-00	B-15	4DA-21511-00	C- 8	3XJ-22253-00	C-13	4JX-23142-L0	C-15
3JE-11931-01	B- 4	137-14143-78	B- 9	4EW-16150-00	B-15	4EW-21611-00	C- 8	4EW-22253-00	C-13		D- 2
3JE-11937-00	B- 3	137-14143-80	B- 9	2K7-16154-00	B-15	39X-21642-00	C- 8	43M-22274-00	C-13	3XJ-23143-L0	C-15
5X4-11952-00	B- 4	509-14145-00	B-10	3SP-16154-00	B-15	3XJ-21668-10	C-12	4JW-22355-00	C-11		D- 2
24X-11953-01	B- 4	3R4-14146-00	B-10	2VM-16181-00	B-15	4EW-21711-01	C- 9	4EW-22474-00	C-13	4DA-23144-L0	C-15
3XK-11956-00	B-15	558-14147-00	B-10	3XK-16321-00	B-15	4EW-2172A-00	C- 9	3JD-22475-00	C-13		D- 2
3SP-11990-00	B- 4	3SP-14149-00	B-10	4X7-16325-00	B-15		C-10	3JE-22475-00	C-13	3XJ-23145-L0	C-15
3SP-11992-10	B- 3	5X5-14153-00	B-10	4EW-16351-00	B-15	4EW-21721-01	C- 9	4GY-22898-50	D- 9		D- 2

NUMERICAL INDEX

PART NO.	GRID NO.	PART NO.	GRID NO.	PART NO.	GRID NO.	PART NO.	GRID NO.	PART NO.	GRID NO.	PART NO.	GRID NO.
4V4-23146-LO	C-15	4JW-24500-00	D- 4	3SP-25919-01	D- 7	90105-10549	D-12	90183-06069	C-10	90240-10117	D-12
	D- 2	4X8-24512-00	D- 4	4GY-25919-50	D- 9	90105-10614	C-13	90185-10120	D-12	90280-03017	B- 5
3JD-23147-LO	C-15	3AJ-24523-00	D- 4	3SP-25924-51	D- 9	90105-10666	D-12	90185-14070	C-12	90338-10150	C-11
	D- 2	3AJ-24534-00	D- 4	3GD-25933-00	D- 7	90105-10733	C- 6	90185-16127	C-11	90340-12097	B-12
3SP-23153-LO	C-15	1UY-24610-00	D- 4	4JX-26111-00	D-10	90106-08051	C- 6	90185-18104	D- 8	90380-16158	C-11
	D- 2	4EW-24728-00	D- 5	1LX-26241-01	D-10	90109-06577	D-15	90201-057H5	B- 4	90387-0602X	C- 9
4V4-23153-LO	C-15	4JW-24731-00	D- 5	1LX-26242-01	D-10	90109-067F4	C- 9	90201-063J2	B- 7		C- 9
	D- 2	4EW-24738-00	D- 5	23X-26243-00	D-10		C- 9	90201-06380	B- 8	90387-0602Y	C- 9
3JD-23158-LO	C-15	4JW-24770-00	D- 5	5X2-2628H-01	D-10	90109-06799	D-15	90201-06697	D- 4		C- 9
	D- 2	4DA-25104-00	D- 6	23X-26281-00	D-10	90109-080G6	D- 7	90201-080E2	C- 6	90387-0603J	C- 9
4JW-2316A-10	C-15	4EW-25111-00	D- 6	431-26282-02	D-10	90109-081G1	D- 8	90201-08087	B- 2		C-10
	D- 2	146-25116-00	D- 6	4AA-26311-00	D-10	90109-142F4	C-11	90201-08326	C- 6	90387-063G3	B-11
4JY-2316A-LO	C-15	4JW-25181-00	D- 6	4EW-26335-00	D-10	90109-147F2	C-11	90201-086P8	C- 7	90387-0701A	C- 8
	D- 2	2VN-25304-00	D- 8	56A-26372-01	D-11	90110-05201	C-11		D- 8	90387-086N4	C- 6
3SP-23166-LO	C-15	4EW-25311-00	D- 8	4JX-27200-00	D-12	90116-08392	B- 2	90201-087A9	B-14	90387-1003E	C- 9
	D- 2	4EW-25317-00	D- 8	4JX-27217-00	D-12	90116-08394	B- 2	90201-08730	C- 6		C- 9
4EW-23167-LO	D- 3	4V4-25367-00	D- 8	3SP-27222-00	D-13	90116-10314	B- 2	90201-08759	B- 6	90387-1003F	C- 9
4JX-23170-LO	C-15	23X-25381-00	D- 8	4AA-27263-00	D-12		B- 2	90201-08784	B- 6		C- 9
	D- 2	3BN-25388-00	D- 8	4JW-27311-00	D-12	90116-10547	B- 2	90201-090J9	D- 7	90387-1003G	D-12
3XJ-23171-LO	C-15	3BN-25389-00	D- 8	4JW-27321-00-T9	D-12		B- 2	90201-101J1	C- 6	90387-102W0	B- 2
	D- 2	39X-25394-00	D- 8	4DA-27411-00	D-12	90119-06063	C- 8	90201-10118	D-11	90387-152F2	B- 4
	C-13	5X2-25394-00	D- 6	4DA-27421-00	D-12	90119-06185	B-11		D-13	90387-160H4	B-12
24M-23184-00	C-13	26A-25444-50	D- 8	4GY-27491-00	D- 9		C- 8	90201-10119	D-12	90387-164N2	C-11
4V4-23194-LO	D- 3	26A-25446-50	D- 8	56A-28166-00	C- 7		C- 8	90201-10774	D-14	90387-164N3	C-11
4EW-2331E-LO	D- 3	26A-25448-50	D- 8	4JX-82310-00	E- 2		C-14	90201-12166	C- 4	90387-167Y9	C-11
4JX-23340-LO	D- 3	26A-25450-50	D- 8	81E-82370-20	E- 2	90119-06225	C- 9	90201-14740	C-12	90387-172Y9	D- 6
4DA-23346-LO	D- 3	26A-25452-50	D- 8	5X1-82519-01	E- 2		C- 9	90201-154E9	B- 4	90387-173Y0	D- 6
3SP-23356-LO	D- 3	4JW-25717-00	D- 7	1UA-82591-00	E- 2	90122-06035	B- 8	90201-164H4	C-11	90387-2000B	D- 8
3SP-23357-LO	D- 2	4MX-2580T-00	D- 7	12R-82591-00	C- 7	90123-08090	D-10		C-12	90387-2000C	D- 8
	D- 3	4GY-2580W-00	D- 9		E- 2	90143-06024	D-15	90201-17545	B-14	90387-252F6	B-15
4JX-23363-LO	C-15	2VN-2582A-50	D-13	38V-82911-00	D-15	90149-06011	D- 4	90201-20278	C- 2	90387-25663	C- 2
	D- 3	4JX-2582T-00	D- 7	38V-82913-00	D-15		D-14	90201-20358	B-14	90401-10159	D-11
3XJ-23364-LO	E- 3	4JX-2582W-00	D- 9	4GY-83912-00	D-15	90149-06272	D- 7	90201-206R3	D- 8		D-13
4DA-23389-00	C-14	4GY-25827-50	D- 9	3SP-83922-00	D-15		D- 9	90201-22555	C- 2	90430-06014	B-13
3SP-23393-LO	C-15	3SP-2583V-00	D-13	25G-83936-01	E- 2	90151-04048	C-11	90201-247L2	C-14	90430-06166	B- 6
	D- 2	2VN-25852-01	D-11	437-83936-01	D-15	90157-06048	B-14	90201-253K0	C- 2	90430-12207	B-12
4EW-23416-00	C-14	3XP-25852-50	D-13	23X-83976-00	D-15	90159-06016	B-15	90201-286K9	C-14	90445-086A8	B-12
4JX-23435-00	C-14	2VN-25854-00	D-13	4EW-85540-00	E- 2	90170-06010	D-15	90202-05187	D- 4	90445-09252	D- 4
3SP-23441-00	C-14	56A-25854-00	D-11	3RB-85547-01	E- 2	90170-20255	B-15	90208-18025	B-15	90445-137H9	D-13
4DA-23485-01	C-14	2VN-25855-00	D-13	3SP-85550-10	D-14	90170-24373	C-14	90209-06096	B- 8	90450-15041	B- 7
4JW-24110-00	D- 4	2VN-25866-00	D-13	3RB-85560-11	D-14	90176-08026	B- 2	90209-17311	C- 2	90450-17036	B- 7
24X-24144-00	D- 4	56A-25867-00	D-11	9Y581-08115	D- 8	90179-06568	C-11	90209-18135	C- 2	90450-22052	B- 7
3SP-24173-00	D- 4	3SP-25870-01	D-11	90101-06664	C- 5	90179-08401	D-10	90209-22082	C- 2	90450-28014	B- 7
22W-24181-00	C- 9	4MX-25872-00	D-11	90105-05361	C-14	90179-10394	D-14	90209-25085	B- 5	90450-51070	B- 8
4EW-24181-00	D- 4	4JX-25873-00	D-13	90105-06639	B- 8	90179-18172	B-15		E- 4	90450-70072	B- 8
4EW-24182-00	D- 4	2VM-25876-00	D-13	90105-08120	C- 6	90179-20255	C- 3	90215-20231	B-15	90464-14117	D- 4
3JD-24186-00	D- 4	3LC-25885-00	D-11	90105-08592	C- 6	90179-28650	C-14	90215-21239	C- 3		D-10
4JW-24311-10	D- 4	4EW-25894-00	D-13	90105-08659	D- 7	90183-06023	C- 8	90240-08120	D-12	90464-16039	B- 8

NUMERICAL INDEX

PART NO.	GRID NO.	PART NO.	GRID NO.	PART NO.	GRID NO.	PART NO.	GRID NO.	PART NO.	GRID NO.	PART NO.	GRID NO.
90465-12362	D-13	93102-12106	C- 5	93410-22039	C- 2	95027-06025	B-13	98507-06030	B-13		
90467-09006	B- 7	93102-12224	B-15	93440-25084	C- 2			98707-04012	D-10		
90467-10008	D- 4	93102-20309	B-14	93450-19052	B- 5				D-11		
90467-11044	D-13	93102-22363	B- 5						B-12		
90468-26048	B-14	93102-32M07	C- 2	93501-04011	B-14	95027-06030	B-13	98707-06012	B-12		
90480-15528	B- 7	93103-10168	B- 6	93511-32027	B-15			98907-06020	D- 4		
90480-16561	B-11	93103-40091	B- 5	93521-64032	B- 4	95027-06035	C- 8	99009-06600	B- 6		
90480-18549	D- 4	93104-08040	B- 4	93603-14179	B- 4	95027-06045	D- 4	99009-17400	B-14		
90501-05265	C- 5	93104-16074	B- 2	93603-22028	B- 6	95027-06050	C-11	99510-10114	B- 2		
90501-06162	D-11	93106-22019	C-11	93604-08071	B- 2	95027-06070	B- 7	99510-12016	B-12		
90501-08364	D- 4	93106-22032	D- 6	93604-10011	B- 6	95027-06080	B- 6		B-13		
90501-13720	B-14	93106-28023	D- 8			95027-08012	B-11	99530-14016	B- 2		
90501-23598	B-15	93109-20029	C-11	93604-29184	B-13	95027-08020	B-14				
90501-240F4	B- 4		C-12	93608-33046	C- 5	95027-08035	C-14				
90506-15480	D-12	93210-09192	B- 3	93834-13030	C- 2				D- 7		
90507-20052	B-11	93210-14104	B-13	93834-14049	C- 2	95027-08040	C- 6		C- 6		
90507-32059	D-12	93210-15620	D-13	93834-15075	C- 3				C-14		
90508-14783	B- 4	93210-16275	B- 6	94108-217X8	D- 6	95027-08065	C- 6		C- 6		
90508-26561	C- 4	93210-19216	B-14	94111-187X9	D- 8	95317-08700	C- 6		C- 6		
90508-28777	D-12	93210-270A8	B- 2	94209-21277	D- 6	95333-08600	D-13		D-13		
90508-291A8	C- 5	93210-56743	B-11	94213-18232	D- 8	95607-05100	B- 8		B- 8		
90508-30743	B-14	93210-77363	B- 2	94330-21084	D- 6	95607-06100	D-15		D-15		
90560-07382	B- 7	93211-11770	B- 2	94340-18086	D- 8				D-15		
90560-08213	B- 4	93300-60804	C- 6	94416-21509	D- 6	95607-08200	C- 6		C- 6		
90560-12280	C- 5	93300-60814	B- 4	94421-18498	D- 8	95617-08100	C- 6		C- 6		
90560-17379	D- 6		B- 4	94681-08011	D- 8				D- 8		
90560-22281	D-10	93306-00316	D- 6	94702-00323	B- 2	95617-10100	C- 6		C- 6		
91A20-05065	B- 7	93306-00418	D- 8	94702-00326	B- 2	95617-10200	C- 6		C- 6		
91317-04006	B- 4	93306-20562	C- 2	94709-00323	B- 2				C-13		
91317-06016	E- 2	93306-20576	C- 2	95024-08040	D- 3	95707-10500	B- 2		B- 2		
91317-06050	B-12	93306-37802	B- 5	95027-06008	B-13	95807-06010	B-12		B-12		
91317-06070	B-12		B- 5						C- 6		
91401-25020	D-12	93310-230T7	B-15	95027-06010	C-11	95817-08035	C- 6		C- 6		
	D-12	93310-418E9	B- 5	95027-06012	B-11	95817-10055	C- 6		C- 6		
	D-12		E- 4			95827-06012	D- 7		D- 7		
91490-20020	D-12	93310-425P2	B- 5			97007-05016	B- 3		B- 3		
92014-06016	D-13		E- 4	95027-06014	C- 9		D-15		D-15		
92017-06010	B-11	93311-41734	C- 2						B- 3		
92901-05100	B- 9	93311-62035	C- 2	95027-06016	C- 8	97007-05020	B- 4		B- 4		
92901-08600	D-12	93315-11206	B-15			97007-05030	C- 5		C- 5		
92907-05100	B- 4	93315-22046	C-11			97017-06025	D-13		D-13		
92907-05600	B- 3		C-12			97780-50110	D- 4		D- 4		
	B- 3	93317-22262	C-11	95027-06020	D- 9	98503-03008	B- 8		B- 8		
92907-06600	B-13	93332-00068	C-14			98507-03008	B- 8		B- 8		
92907-08200	D- 7	93332-00078	C-14			98507-05008	B- 3		B- 3		
92907-10200	C- 6	93340-21505	B- 4	95027-06025	C- 9	98507-05012	B- 2		B- 2		
92990-03100	B- 8	93342-22215	C-11			98507-05016	B- 9		B- 9		
92990-10200	D-12	93410-20038	C- 2				D-10		D-10		
						98507-06012	B-12		B-12		

*COPY RIGHT: All rights reserved. No part of this publication
may be reproduced without permission.*

YAMAHA

YAMAHA MOTOR CO., LTD.
2500 SHINGA I IWATA SHIZUOKA JAPAN
SERVICE INFORMATION DIV.

Printed in Japan
First edition SEP., 1994