

# PARTS CATALOGUE

## WR250F (5UMM) OCEANIA, SOUTH AFRICA

---

WR250F  
PARTS CATALOGUE  
©2007 by Yamaha Motor Co., Ltd.  
1st edition, September 2007  
All rights reserved.  
Any reprinting or unauthorized use  
without the written permission of  
Yamaha Motor Co., Ltd.  
is expressly prohibited.  
Printed in Japan.

**A3**

# FOREWORD

This Parts Catalogue is related to the parts for the model(s) on the cover page. When you are ordering replacement parts, please refer to this Parts Catalogue and quote both part numbers and part names correctly.

1. Modifications or additions which have been made after the issue of the Parts Catalogue will be announced in the Parts News.

It is advisable that you make the necessary corrections to the Parts Catalogue according to the Parts News.

2. Abbreviations

The following abbreviations are used in this Parts Catalogue.

“UR” Use specified parts number.

“UN” Use as many as needed.

“AP” Alternate Parts

“LM” Locally Made (Parts need to be ordered locally)

“F#” Frame No. (Applicable machine No.)

“O/S” Over Size

3. The number of components for assembly

- Parts, which are to be supplied in an assembly, are listed with a dot (.) in front of the part name as shown below.
- The numeral appearing to the right of each component part indicates the quantity of parts for each assembly unit.

PART NO.	DESCRIPTION	Q'TY	REMARKS
2F5-83310-60	FRONT FLASHER LIGHT ASSY	2	
115-83311-60	.BULB (6V-18W)	1	

4. Applicable colours of graphics are represented in the “REMARKS” as shown below.

PART NO.	DESCRIPTION	Q'TY	REMARKS
2N4-24110-00-X5	FUEL TANK COMP.	2	MXR
3J1-24240-10	.GRAPHIC, FUEL TANK	1	FOR MXR

5. Note that the illustrations for reference in finding parts numbers are not to be used for assembling. When assembling, please use the applicable service manual.

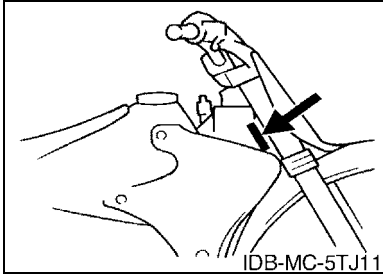
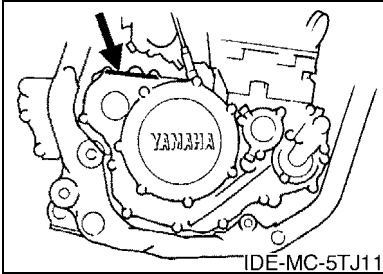
6. The asterisk (\*) before a reference number indicates modified items after the first edition.

# FOREWORD

7. Applicable Serial No.

Engine Serial No.

Frame Serial No.



8. Applicable Colour Code (The (\*) mark shows Model colour.)

Abbreviation	Colour Name	Colour Code
DPBSE(*)	DEEP PURPLISH BLUE SOLID E	0583

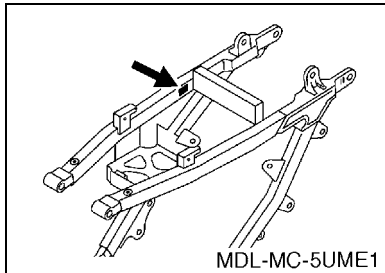
# MODEL LABEL

(1) A label called "Model Label" is affixed in the location as indicated in (3) below.  
When using this parts catalogue, please be sure to cross-reference the "model code – production code No." in the catalogue with the "model code – production code No." indicated on the Model Label affixed onto the product concerned.

(2) "Model Label" Indication

<table style="border: none;"> <tr> <td style="padding-right: 10px;">a</td> <td>b</td> </tr> <tr> <td>○ xxxx – xxx</td> <td></td> </tr> <tr> <td>● x<sup>c</sup></td> <td></td> </tr> </table>	a	b	○ xxxx – xxx		● x <sup>c</sup>		<p>a: Model Type Code b: Production Code No. c: Colouring Type</p>	<table style="border: none;"> <tr> <td style="padding-right: 10px;">○ 4TW1-010</td> </tr> <tr> <td>● A</td> </tr> </table>	○ 4TW1-010	● A
a	b									
○ xxxx – xxx										
● x <sup>c</sup>										
○ 4TW1-010										
● A										

(3) Model Label Affixing Location



(4) Colouring Information

Model Code	Colouring Type Code	Colour Code	Colour Name	Abbrevia-tion
5UMM	A	0583	DEEP PURPLISH BLUE SOLID E	DPBSE

(5) Model Code – Production Code Number of Model Listed in This Parts Catalogue

Model Code	Production Code No.	Country (destination)	Model Code	Production Code No.	Country (destination)
5UMM	010	AUSTRALIA			
		NEW ZEALAND			
	020	SOUTH AFRICA			

# CONTENTS

## ENGINE

CYLINDER .....	B2
CRANKSHAFT & PISTON .....	B4
VALVE .....	B5
CAMSHAFT & CHAIN .....	B7
WATER PUMP .....	B8
RADIATOR & HOSE .....	B9
OIL PUMP .....	B10
OIL CLEANER .....	B12
INTAKE .....	B13
CARBURETOR .....	B15
AIR INDUCTION SYSTEM .....	C5
EXHAUST .....	C6
CRANKCASE .....	C7
CRANKCASE COVER 1 .....	C8
STARTER .....	C10
STARTER CLUTCH .....	C11
CLUTCH .....	C12
TRANSMISSION .....	C14
SHIFT CAM & FORK .....	D2
SHIFT SHAFT .....	D3

## CHASSIS

FRAME .....	D4
FENDER .....	D6
SIDE COVER .....	D7
REAR ARM .....	D8
REAR SUSPENSION .....	D10
STEERING .....	D11
FRONT FORK .....	D12
FUEL TANK .....	D14
SEAT .....	E2
FRONT WHEEL .....	E3
FRONT BRAKE CALIPER .....	E4
REAR WHEEL .....	E5
REAR BRAKE CALIPER .....	E7
STEERING HANDLE & CABLE .....	E8
FRONT MASTER CYLINDER .....	E9
STAND & FOOTREST .....	E10
REAR MASTER CYLINDER .....	E11
GENERATOR .....	E12
STARTING MOTOR .....	E13

METER .....	E14
HEADLIGHT .....	E15
TAILLIGHT .....	F2
HANDLE SWITCH & LEVER .....	F3
ELECTRICAL 1 .....	F4
ALTERNATE FOR CHASSIS .....	F6

## INDEX

NUMERICAL INDEX .....	M1
-----------------------	----

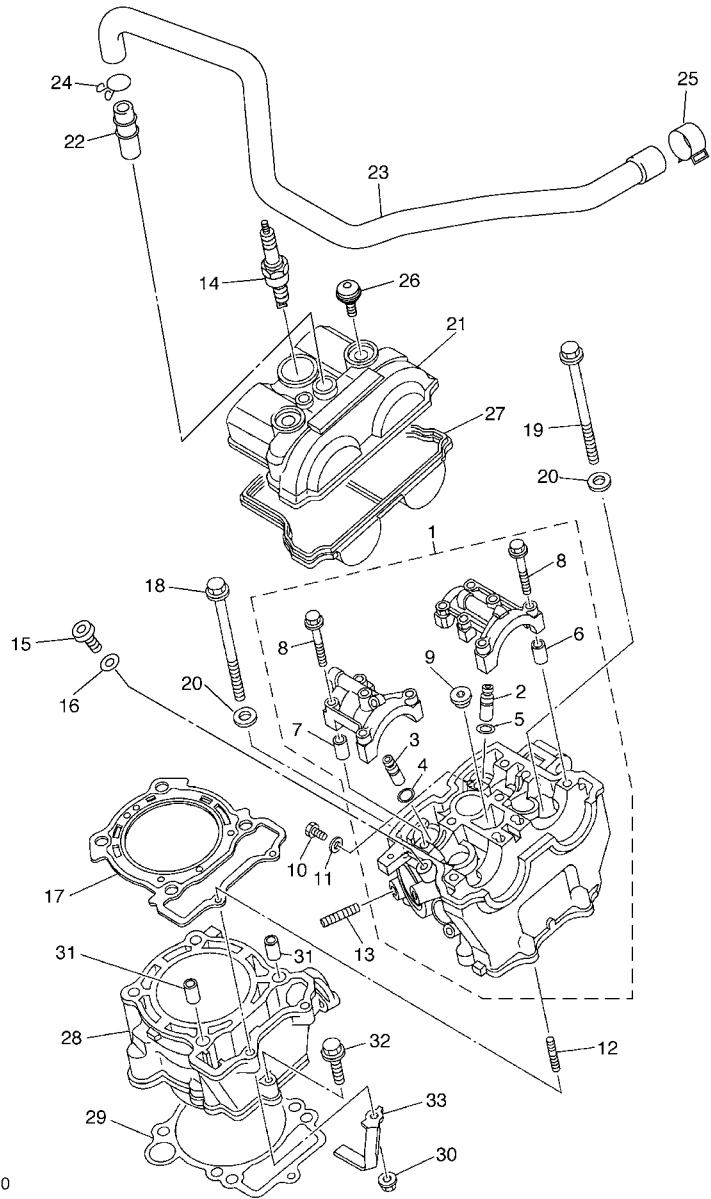
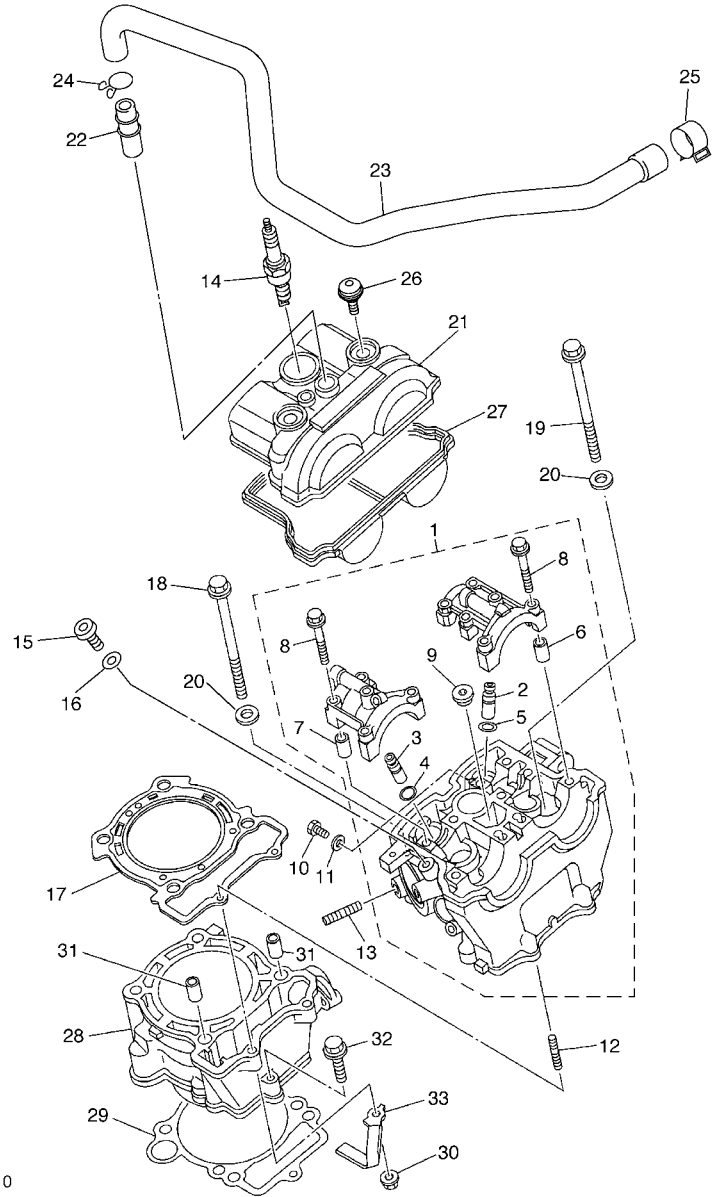


FIG. 1 CYLINDER

REF. NO.	PART NO.	DESCRIPTION	SUMM				REMARKS
1	5UM-11101-10	CYLINDER HEAD ASSY	1				
2	5XC-11133-10	.GUIDE, VALVE 1	3				
3	5NL-11134-10	.GUIDE, VALVE 2	2				
4	93440-10153	.CIRCLIP	2				
5	93440-07149	.CIRCLIP	3				
6	91808-16023	.PIN, DOWEL	2				
7	91808-16023	.PIN, DOWEL	2				
8	90105-06027	.BOLT, FLANGE	10				
9	90340-12007	.PLUG, STRAIGHT SCREW	1				
10	95022-06010	BOLT, FLANGE	1				
11	90430-06014	GASKET	1				
12	90116-06038	BOLT, STUD	2				
13	95612-08620	BOLT, STUD	2				
14	94701-00410	PLUG, SPARK (NGK R CR9E)	1				STD
	94701-00411	PLUG, SPARK (NGK R CR8E)	1				AP
15	90340-12007	PLUG, STRAIGHT SCREW	1				
16	90201-12790	WASHER, PLATE	1				
17	5NL-11181-00	GASKET, CYLINDER HEAD 1	1				
18	90105-09004	BOLT, FLANGE	2				
19	90105-09002	BOLT, FLANGE	2				
20	90201-096J9	WASHER, PLATE	4				
21	5NL-11191-30	COVER, CYLINDER HEAD 1	1				
22	371-11167-01	PIPE, BREATHER 2	1				
23	5UM-11166-00	PIPE, BREATHER 1	1				
24	90467-140A4	CLIP	1				
25	90467-17089	CLIP	1				
26	5UM-1119E-00	BOLT, COVER HEAD	2				



5UM100-F010



5UME100-F010

FIG. 1 CYLINDER

REF. NO.	PART NO.	DESCRIPTION	SUMM				REMARKS
27	5NL-11193-00	GASKET, HEAD COVER 1	1				
28	5XC-11311-10	CYLINDER 1	1				
29	5NL-11351-00	GASKET, CYLINDER	1				
30	95702-06500	NUT, WITH WASHER	2				
31	93612-16254	PIN, DOWEL	2				
32	95022-06035	BOLT, FLANGE	1				
33	5UM-11387-00	CLAMP, HOSE 1	1				





5UME100-F020

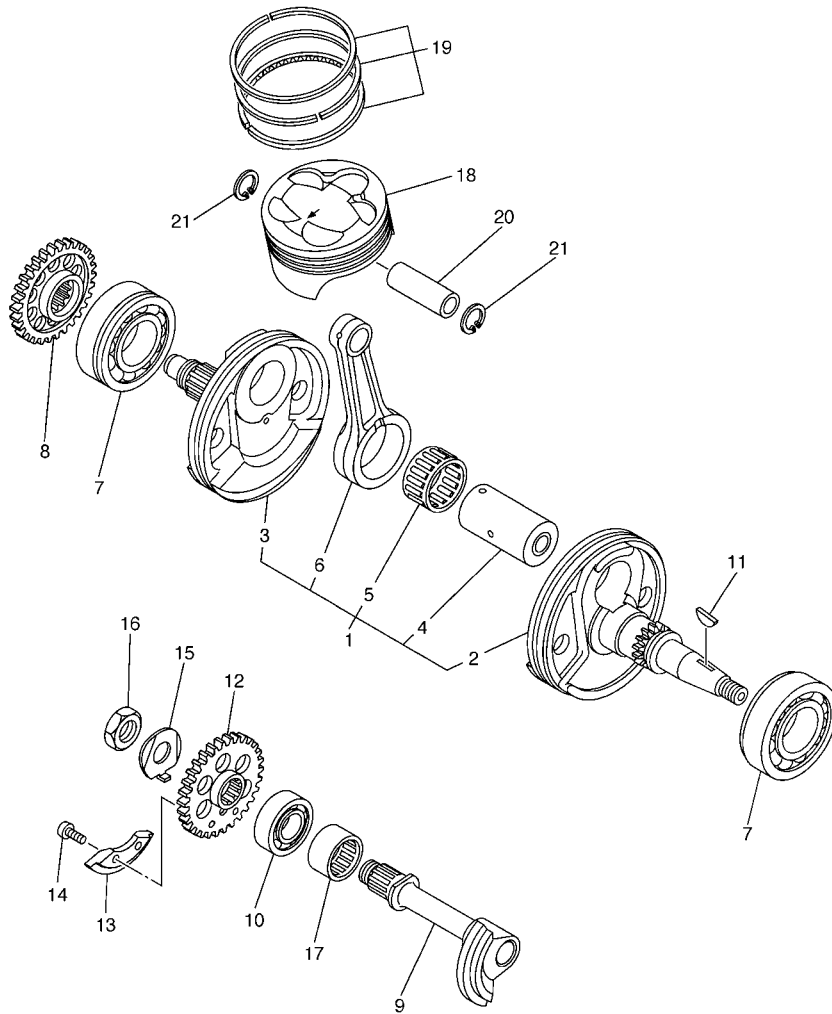
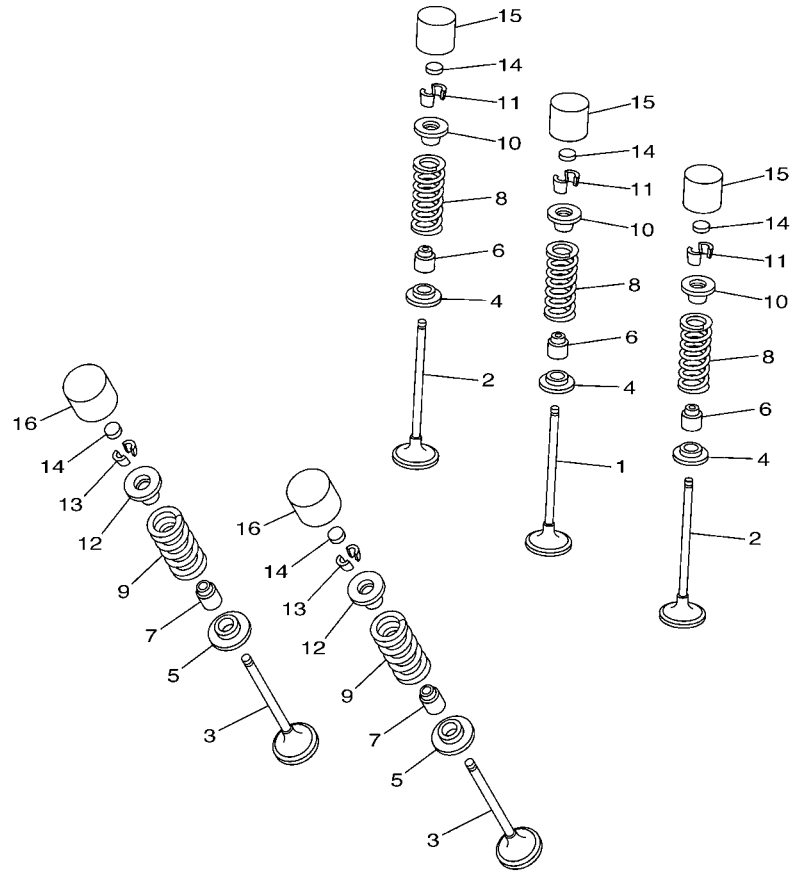


FIG. 2 CRANKSHAFT & PISTON

REF. NO.	PART NO.	DESCRIPTION	SUMM				REMARKS
1	5UM-11400-30	CRANKSHAFT ASSY	1				
2	5UM-11412-20	.CRANK 1	1				
3	5UL-11422-10	.CRANK 2	1				
4	5XC-11681-00	.PIN, CRANK 1	1				
5	93310-63238	.BEARING	1				
6	5XC-11651-00	.ROD, CONNECTING	1				
7	93306-20648	BEARING	2				
8	5NL-11536-10	GEAR, DRIVE	1				
9	5NL-11455-00	SHAFT 1	1				
10	93306-20335	BEARING	1				
11	90280-03006	KEY, WOODRUFF	1				
12	5NL-11531-00	GEAR, BALANCE WEIGHT	1				
13	5NL-11454-00	WEIGHT 1	1				
14	90149-06084	SCREW	2				
15	90215-14204	WASHER, LOCK	1				
16	90170-14171	NUT	1				
17	93311-32261	BEARING	1				
18	5NL-11631-20	PISTON (STD)	1				
19	5NL-11603-00	PISTON RING SET (STD)	1				
20	5NL-11633-00	PIN, PISTON	1				
21	93420-16086	CIRCLIP	2				



5NL1100-1030

FIG. 3 VALVE

REF. NO.	PART NO.	DESCRIPTION	SUMM				REMARKS
1	5NL-12111-20	VALVE, INTAKE	1				
2	5NL-12112-20	VALVE, INTAKE 2	2				
3	5NL-12121-10	VALVE, EXHAUST	2				
4	5NL-12116-00	SEAT, VALVE SPRING	3				
5	3GM-12126-00	SEAT, VALVE SPRING 2	2				
6	4TV-12119-00	SEAL, VALVE STEM	3				
7	4SV-12119-00	SEAL, VALVE STEM	2				
8	5UM-12113-00	SPRING, VALVE INNER	3				
9	5NL-12114-00	SPRING, VALVE OUTER	2				
10	1HX-12117-00	RETAINER, VALVE SPRING	3				
11	1HX-12118-00	COTTER, VALVE	6				
12	1WG-12117-00	RETAINER, VALVE SPRING	2				
13	1WG-12118-00	COTTER, VALVE	4				
14	1HX-12168-00	PAD, ADJUSTING 2 (1.20)	5				UR
	1HX-12168-20	PAD, ADJUSTING 2 (1.25)	5				UR
	1HX-12168-40	PAD, ADJUSTING 2 (1.30)	5				UR
	1HX-12168-60	PAD, ADJUSTING 2 (1.35)	5				UR
	1HX-12168-80	PAD, ADJUSTING 2 (1.40)	5				UR
	1HX-12168-A0	PAD, ADJUSTING 2 (1.45)	5				UR
	1HX-12168-F0	PAD, ADJUSTING 2 (1.50)	5				UR
	1HX-12168-H1	PAD, ADJUSTING 2 (1.55)	5				UR
	1HX-12168-K1	PAD, ADJUSTING 2 (1.60)	5				UR
	1HX-12168-M1	PAD, ADJUSTING 2 (1.65)	5				UR
	1HX-12168-R1	PAD, ADJUSTING 2 (1.70)	5				UR
	1HX-12168-U1	PAD, ADJUSTING 2 (1.75)	5				UR
	1HX-12168-W1	PAD, ADJUSTING 2 (1.80)	5				UR
	1HX-12168-Y1	PAD, ADJUSTING 2 (1.85)	5				UR

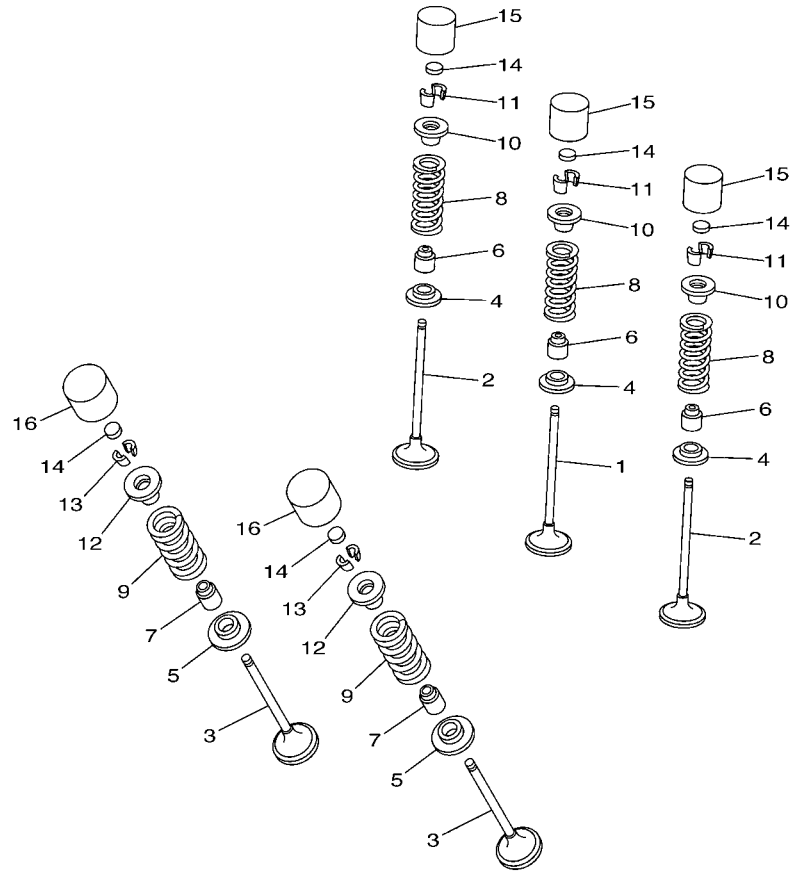
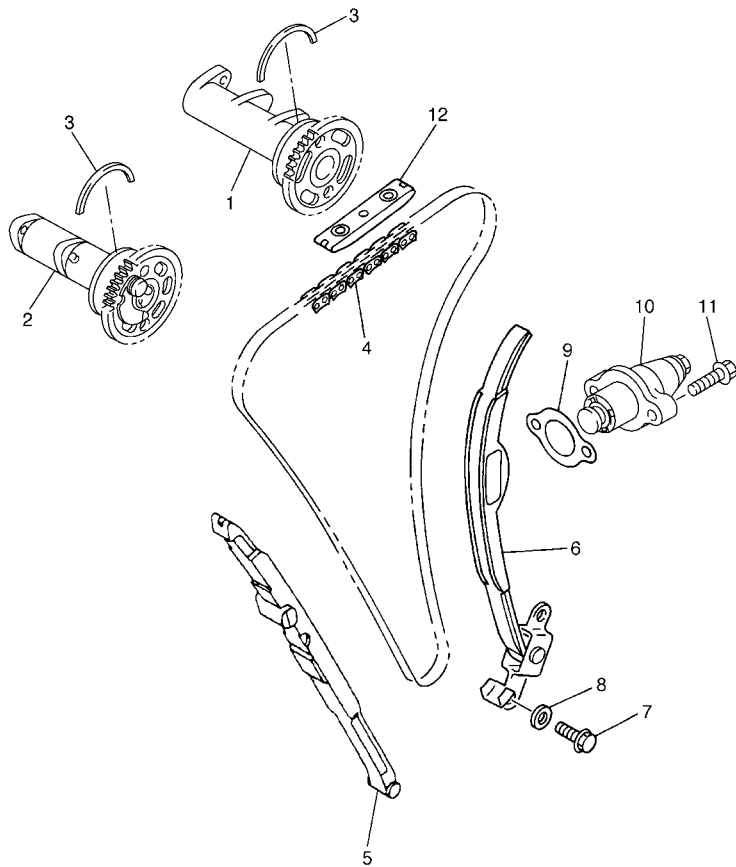


FIG. 3 VALVE

REF. NO.	PART NO.	DESCRIPTION	SUMM				REMARKS
14	1HX-12169-11	PAD, ADJUSTING 2 (1.90)	5				UR
	1HX-12169-31	PAD, ADJUSTING 2 (1.95)	5				UR
	1HX-12169-50	PAD, ADJUSTING 2 (2.00)	5				UR
	1HX-12169-70	PAD, ADJUSTING 2 (2.05)	5				UR
	1HX-12169-90	PAD, ADJUSTING 2 (2.10)	5				UR
	1HX-12169-E0	PAD, ADJUSTING 2 (2.15)	5				UR
	1HX-12169-G0	PAD, ADJUSTING 2 (2.20)	5				UR
	1HX-12169-J0	PAD, ADJUSTING 2 (2.25)	5				UR
	1HX-12169-L0	PAD, ADJUSTING 2 (2.30)	5				UR
	1HX-12169-N0	PAD, ADJUSTING 2 (2.35)	5				UR
	1HX-12169-T0	PAD, ADJUSTING 2 (2.40)	5				UR
15	3LN-12153-10	LIFTER, VALVE	3				YELLOW
16	3FV-12153-10	LIFTER, VALVE	2				YELLOW



5NL1100-1030

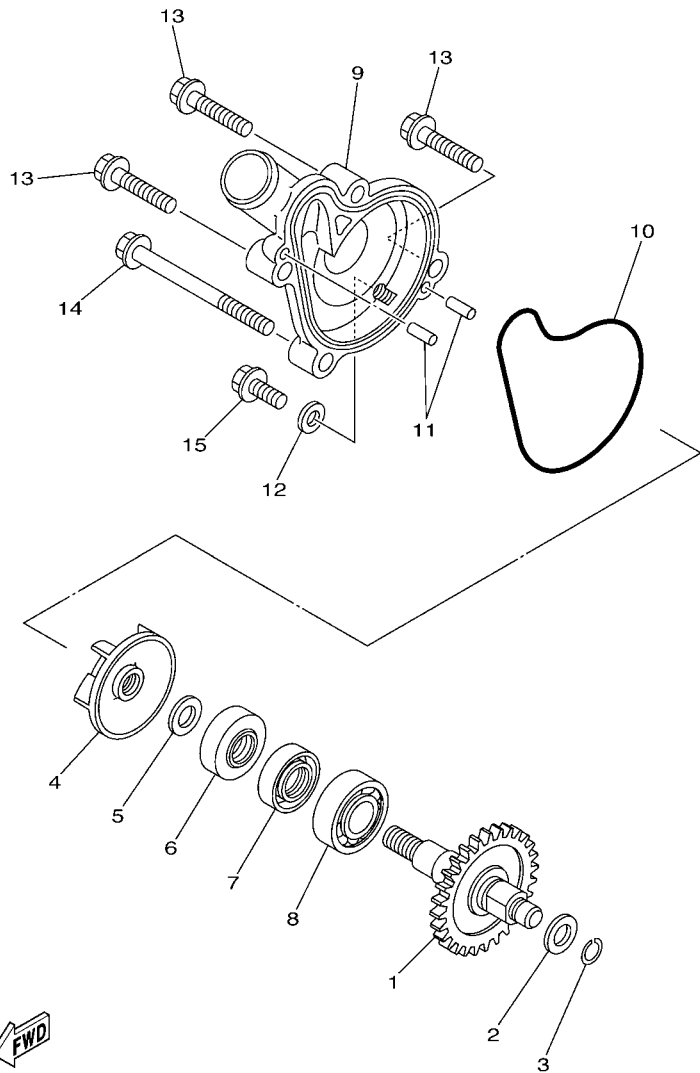


**FIG. 4 CAMSHAFT & CHAIN**

REF. NO.	PART NO.	DESCRIPTION	SUMM				REMARKS
1	5UM-12170-10	CAMSHAFT ASSY 1	1				
2	5UM-12180-20	CAMSHAFT ASSY 2	1				
3	93440-41178	CIRCLIP	2				
4	94591-53114	CHAIN	1				
5	5NL-12251-10	DAMPER, CHAIN 1	1				
6	5NL-12252-00	DAMPER, CHAIN 2	1				
7	97022-06016	BOLT	2				
8	92902-06600	WASHER, PLATE	2				
9	4FM-12213-00	GASKET, TENSIONER CASE	1				
10	5TA-12210-20	TENSIONER ASSY, CAM CHAIN	1				
11	95022-06025	BOLT, FLANGE	2				
12	5BE-12241-00	GUIDE, STOPPER 2	1				



5UMB100-E040



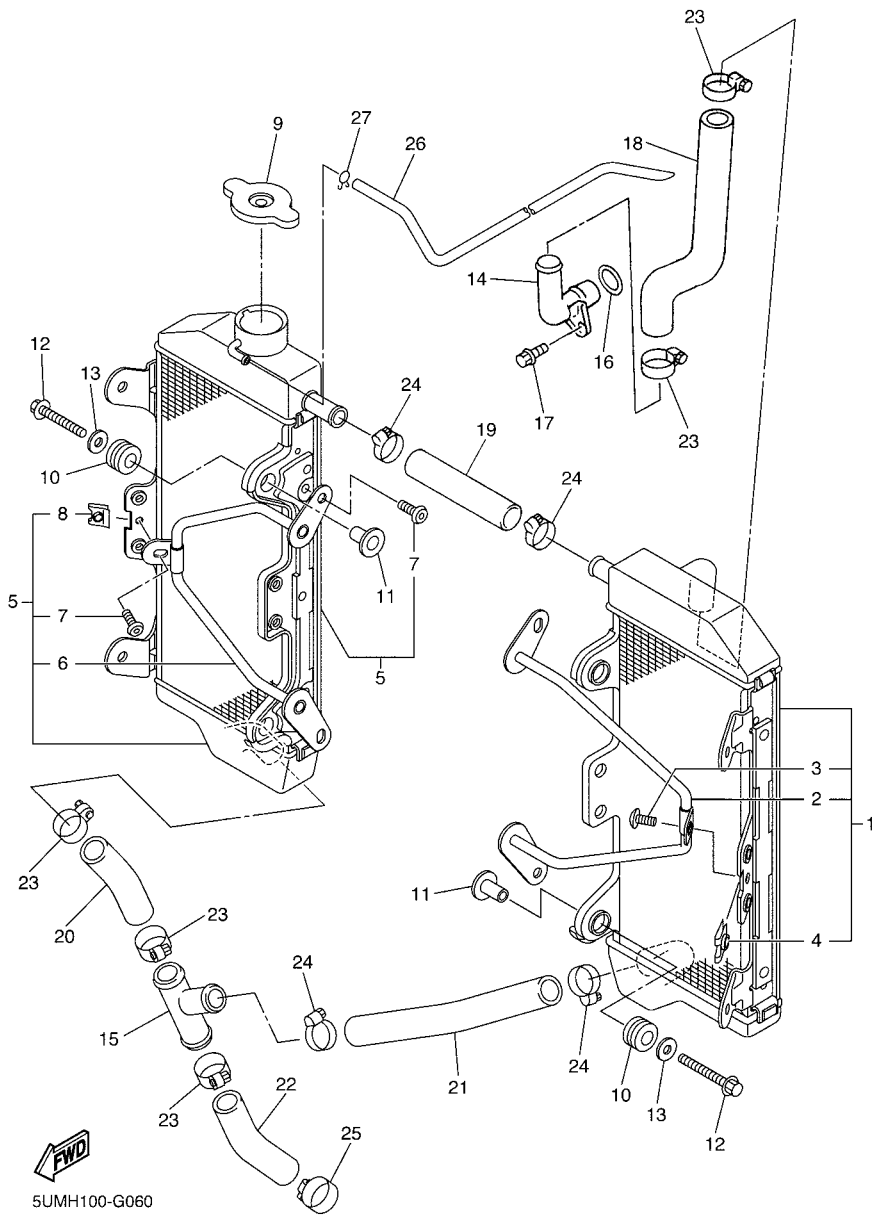
**FWD**  
5NL1100-1050

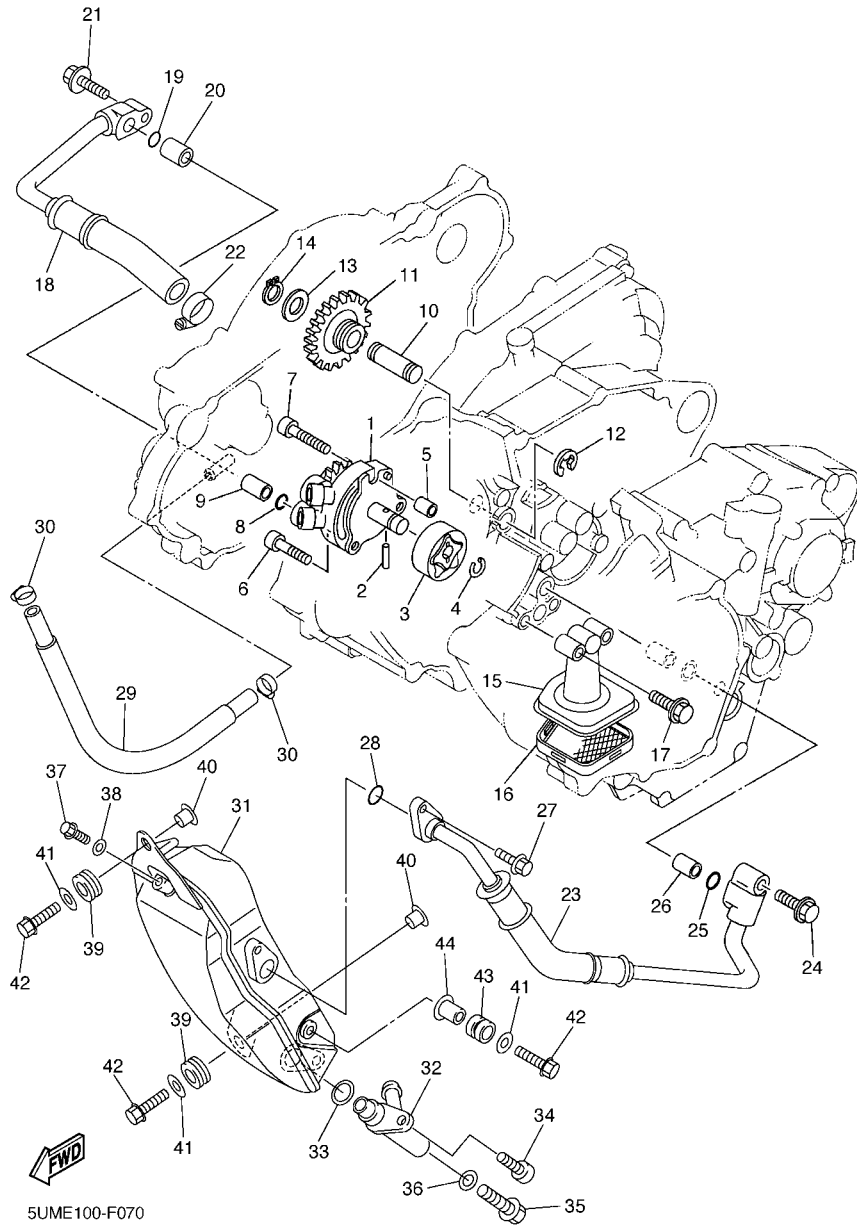
**FIG. 5 WATER PUMP**

REF. NO.	PART NO.	DESCRIPTION	SUMM				REMARKS
1	5XC-12459-00	GEAR, IMPELLER SHAFT	1				
2	90201-08512	WASHER, PLATE	1				
3	93440-07182	CIRCLIP	1				
4	5DH-12451-00	IMPELLER, WATER PUMP	1				
5	90201-08512	WASHER, PLATE	1				
6	93109-11073	OIL SEAL	1				
7	93102-12106	OIL SEAL (SD 12-22-5 HS)	1				
8	93306-00105	BEARING	1				
9	5NL-12422-10	COVER, HOUSING	1				
10	5NL-12439-00	O-RING	1				
11	93604-10011	PIN, DOWEL	2				
12	90430-06014	GASKET	1				
13	95022-06025	BOLT, FLANGE	3				
14	95022-06065	BOLT, FLANGE	1				
15	95022-06012	BOLT, FLANGE	1				

FIG. 6 RADIATOR & HOSE

REF. NO.	PART NO.	DESCRIPTION	SUMM				REMARKS
1	5UM-1240A-E0	RADIATOR ASSY	1				
2	2S2-12464-70	.STAY, RADIATOR	1				
3	92012-06010	.BOLT, BUTTON HEAD	3				
4	90183-060A6	.NUT, SPRING	1				
5	5UM-12461-E0	RADIATOR ASSY	1				
6	2S2-12464-70	.STAY, RADIATOR	1				
7	92012-06010	.BOLT, BUTTON HEAD	3				
8	90183-060A6	.NUT, SPRING	1				
9	22W-12462-00	CAP, RADIATOR	1				
10	90480-15528	GROMMET	4				
11	90387-06065	COLLAR	4				
12	90105-06111	BOLT, FLANGE	4				
13	90201-06571	WASHER, PLATE	4				
14	5XC-12481-90	PIPE 1	1				
15	5XC-12482-90	PIPE 2	1				
16	93210-15414	O-RING	1				
17	91312-06012	BOLT	1				
18	5XC-12576-90	HOSE 1	1				
19	1C3-12482-00	PIPE 2	1				
20	5XC-12578-90	HOSE 3	1				
21	5XC-12579-91	HOSE 4	1				
22	5XC-1244H-90	HOSE 5	1				
23	90450-25001	HOSE CLAMP ASSY	5				
24	90450-22001	HOSE CLAMP ASSY	4				
25	90450-32003	HOSE CLAMP ASSY	1				
26	91A20-05140	TUBE, FLEXIBLE VINYL	1				
27	90467-090A2	CLIP	1				

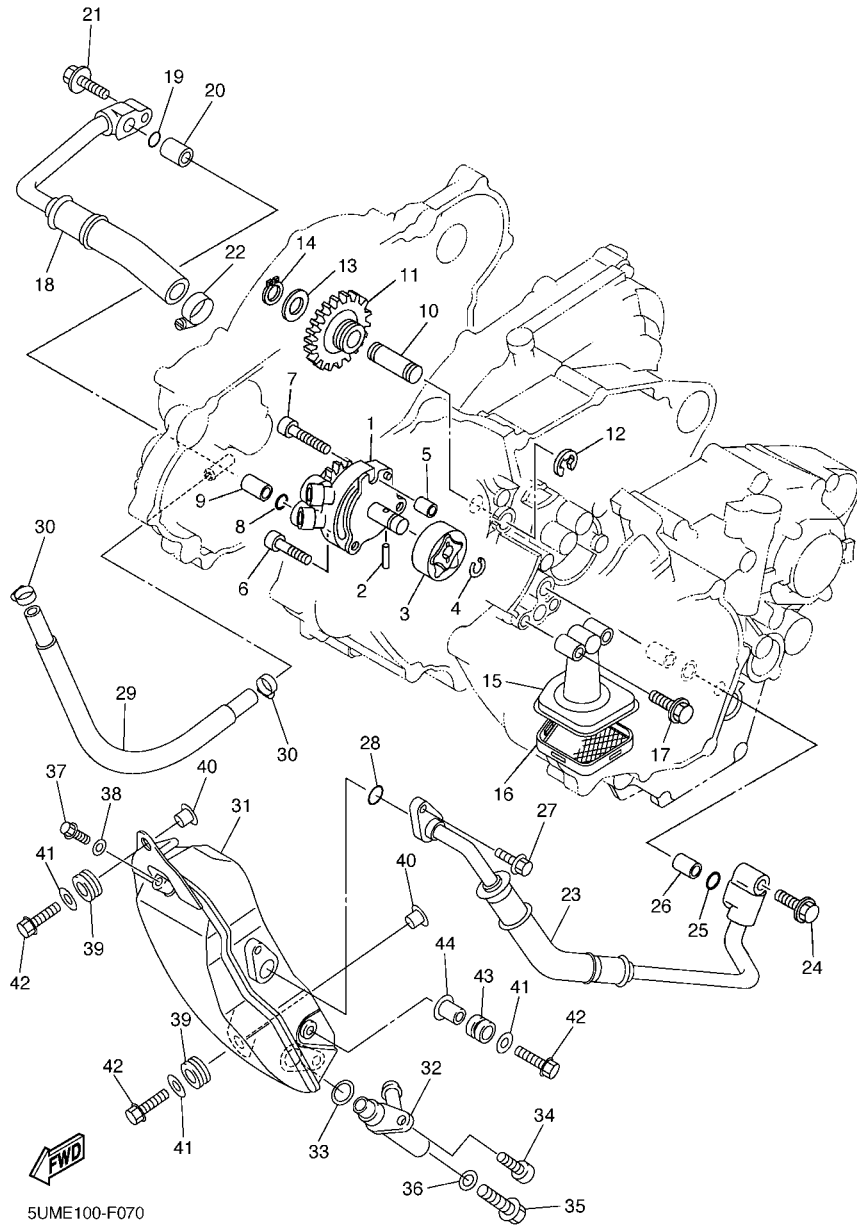




5UME100-F070

FIG. 7 OIL PUMP

REF. NO.	PART NO.	DESCRIPTION	SUMM				REMARKS
1	5SG-13300-00	OIL PUMP ASSY	1				
2	93603-16219	PIN, DOWEL	1				
3	5NL-13320-00	ROTOR ASSY 2	1				
4	93440-10153	CIRCLIP	1				
5	99530-08012	PIN, DOWEL	1				
6	91312-06025	BOLT	2				
7	91317-06030	BOLT	1				
8	93210-10197	O-RING	1				
9	99530-10114	PIN, DOWEL	1				
10	5BE-13342-00	SHAFT, IDLE GEAR	1				
11	5NL-13341-00	GEAR, OIL PUMP IDLE	1				
12	99001-08600	CIRCLIP	1				
13	90201-12166	WASHER, PLATE	1				
14	99009-12400	CIRCLIP	1				
15	5XC-13412-00	HOUSING, STRAINER	1				
16	5NL-13411-00	STRAINER, OIL	1				
17	95022-06025	BOLT, FLANGE	2				
18	5XC-13464-20	HOSE, OIL 1	1				
19	93210-10197	O-RING	1				
20	99530-10114	PIN, DOWEL	1				
21	95022-06025	BOLT, FLANGE	1				
22	90450-22001	HOSE CLAMP ASSY	1				
23	5XC-13465-10	HOSE, OIL 2	1				
24	95022-06025	BOLT, FLANGE	1				
25	93210-10197	O-RING	1				
26	99530-10114	PIN, DOWEL	1				
27	95022-06016	BOLT, FLANGE	1				



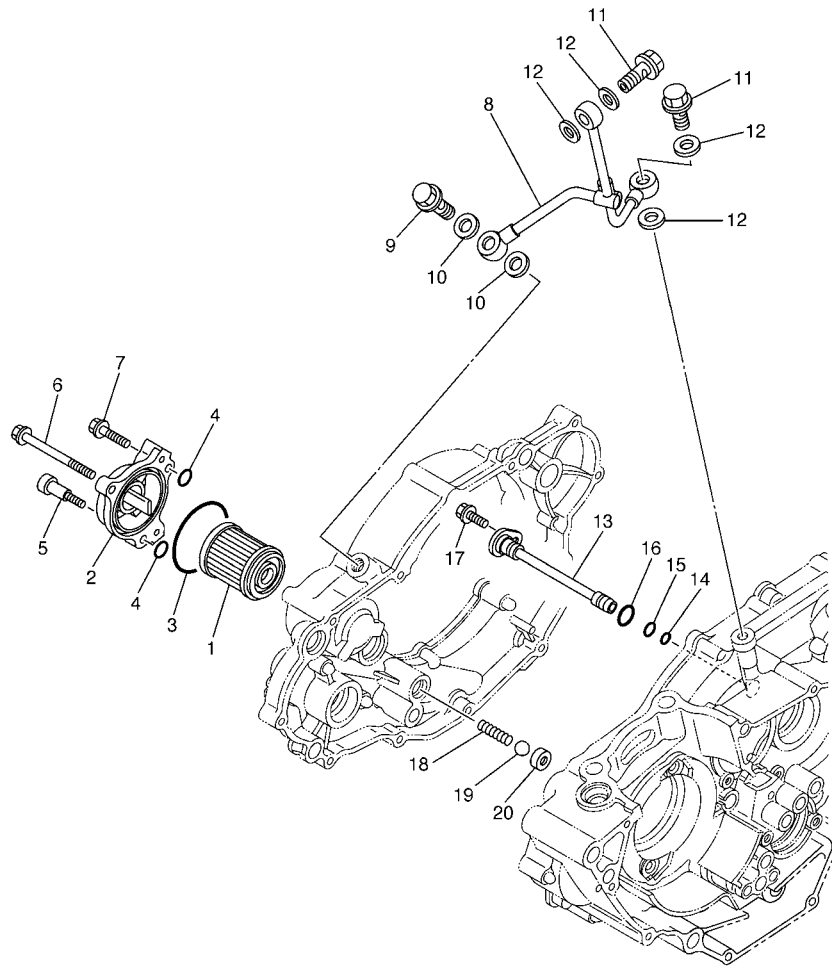
5UME100-F070

FIG. 7 OIL PUMP

REF. NO.	PART NO.	DESCRIPTION	SUMM				REMARKS
28	93210-09754	O-RING	1				
29	90445-14010	HOSE	1				
30	90450-17001	HOSE CLAMP ASSY	2				
31	5XC-21751-90	TANK, OIL	1				
32	5XC-13416-90	PIPE, OIL 1	1				
33	93210-14369	O-RING	1				
34	91312-06016	BOLT	1				
35	90105-08151	BOLT, FLANGE	1				
36	90201-082A6	WASHER, PLATE	1				
37	90105-06128	BOLT, FLANGE	1				
38	90201-06630	WASHER, PLATE	1				
39	90480-10289	GROMMET	2				
40	90387-06150	COLLAR	2				
41	90201-06571	WASHER, PLATE	3				
42	90105-06112	BOLT, FLANGE	3				
43	90480-14433	GROMMET	1				
44	90387-06161	COLLAR	1				



**FIG. 8 OIL CLEANER**

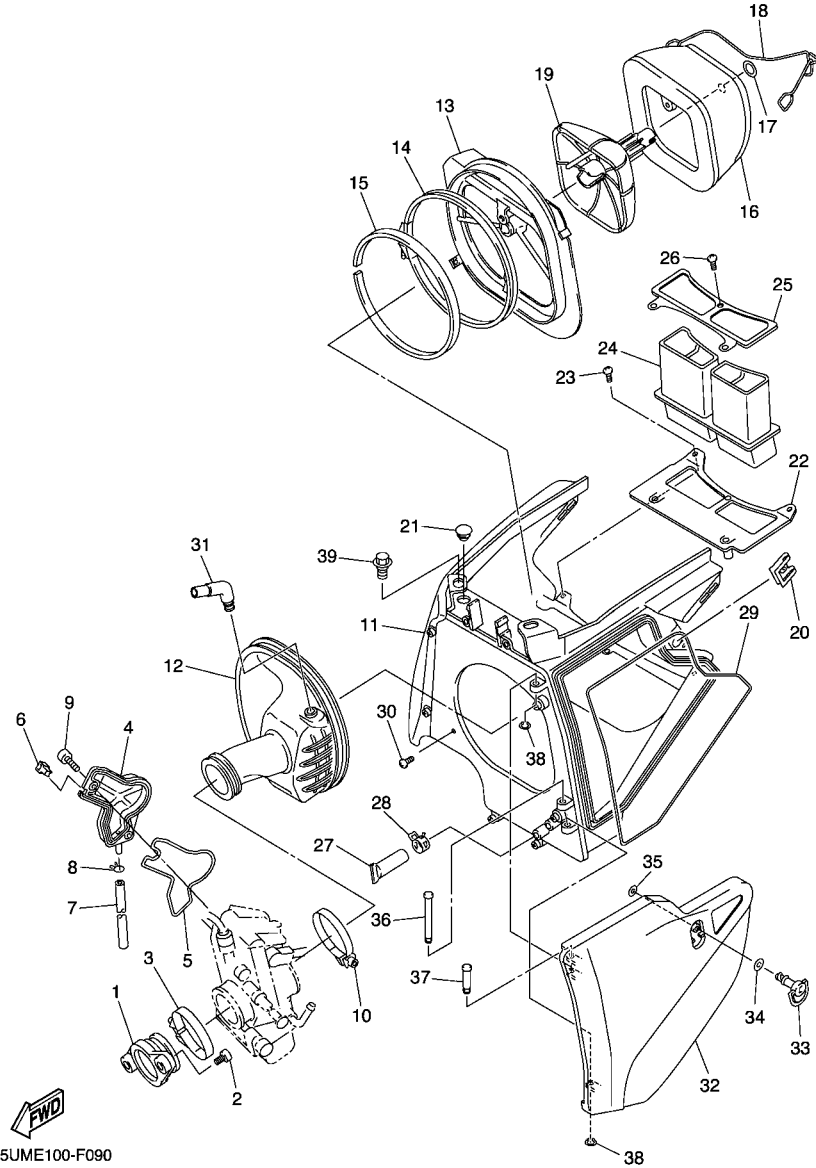


REF. NO.	PART NO.	DESCRIPTION	SUMM				REMARKS
1	5TA-13440-00	ELEMENT ASSY, OIL CLEANER	1				
2	5BE-13447-20	COVER, OIL ELEMENT	1				
3	93210-47675	O-RING	1				
4	93210-07135	O-RING	3				
5	90110-06228	BOLT, HEXAGON SOCKET HEAD	1				
6	91312-06065	BOLT	1				
7	91312-06025	BOLT	1				
8	5NL-13161-20	PIPE, DELIVERY 1	1				
9	90401-10015	BOLT, UNION	1				
10	90430-10188	GASKET	2				
11	90401-08006	BOLT, UNION	2				
12	90430-08119	GASKET	4				
13	5NL-13171-00	PIPE, DELIVERY 2	1				
14	93210-07003	O-RING	1				
15	93210-09008	O-RING	1				
16	93210-12759	O-RING	1				
17	95022-06012	BOLT, FLANGE	1				
18	90501-043E0	SPRING, COMPRESSION	1				
19	93503-08007	BALL	1				
20	583-13113-00	SEAT, CHECK BALL	1				



5XC9100-E080

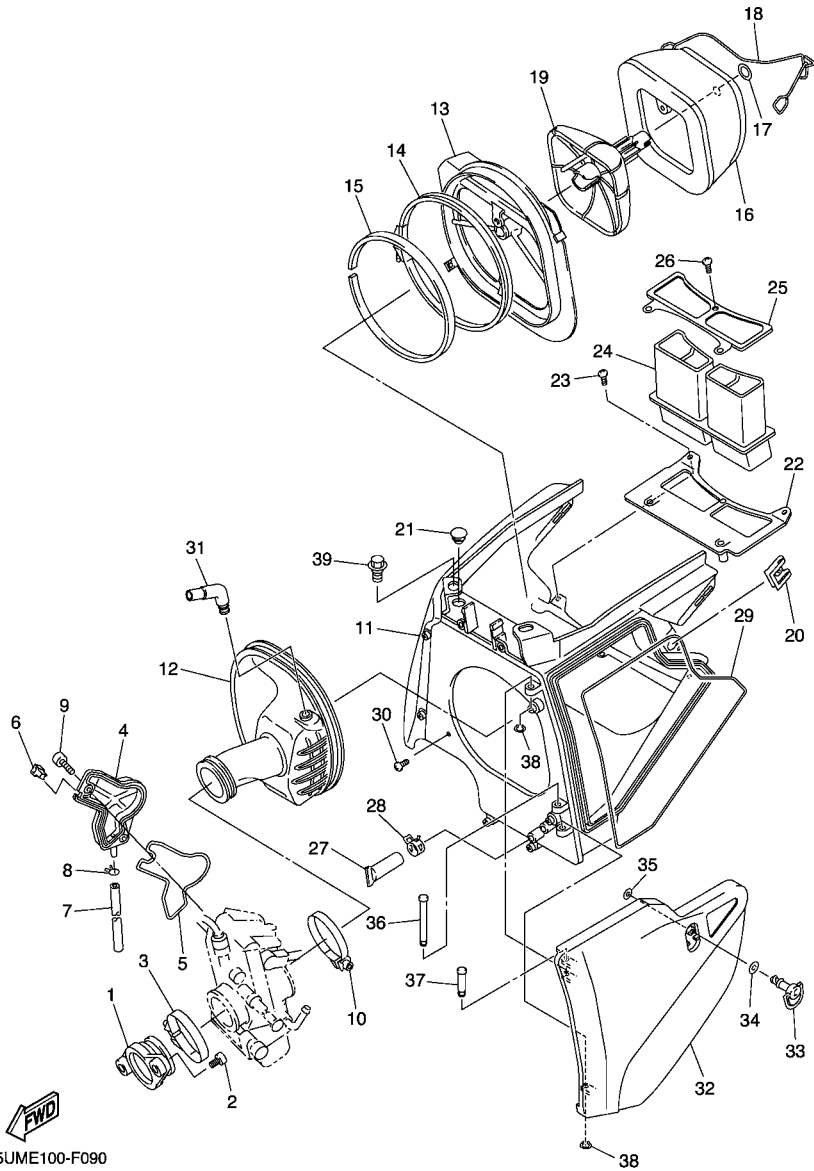
FIG. 9 INTAKE



5UME100-F090

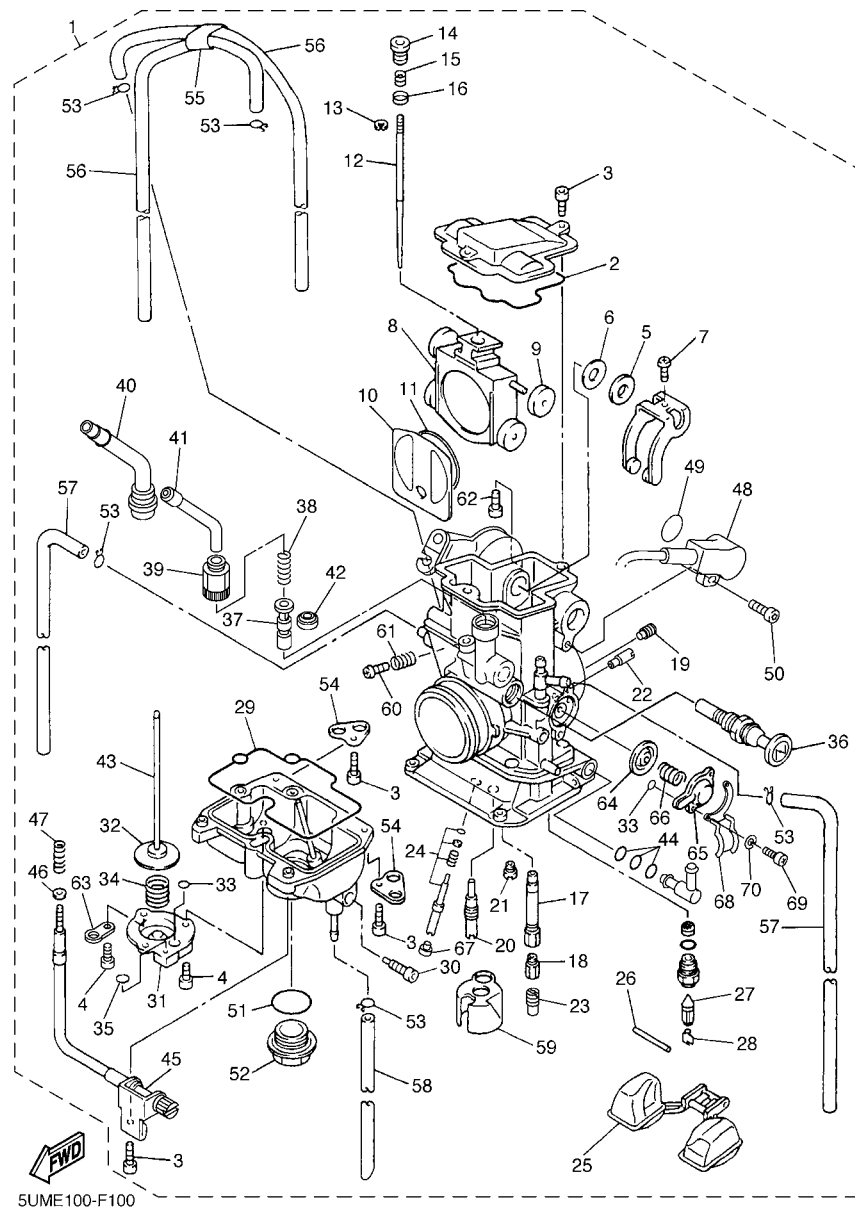
REF. NO.	PART NO.	DESCRIPTION	SUMM				REMARKS
1	5XC-13597-30	JOINT, CARBURETOR 3	1				
2	91312-06025	BOLT	2				
3	90450-57010	HOSE CLAMP ASSY	1				
4	5TA-14293-00	COVER 1	1				
5	5TA-14227-00	GASKET	1				
6	5TA-14239-00	SEAL	1				
7	5TA-14987-00	HOSE	1				
8	3TJ-14137-40	CLIP	1				
9	90110-05038	BOLT, HEXAGON SOCKET HEAD	2				
10	90450-61002	HOSE CLAMP ASSY	1				
11	5UM-14401-E0	AIR CLEANER CASE ASSY	1				
12	5UM-14453-E0	JOINT, AIR CLEANER 1	1				
13	5TJ-14459-01	HOLDER, GUIDE	1				
14	5NY-14455-20	BAND	1				
15	5NY-14442-00	SPACER	1				
16	5UM-14451-E0	ELEMENT, AIR CLEANER	1				
17	5TJ-14475-00	WASHER	1				
18	5UM-1441G-E0	BINDER 1	1				
19	5TJ-14458-00	GUIDE	1				
20	4XV-2177L-01	PLATE, SPRING	1				
21	90338-07043	PLUG	1				
22	5UM-14437-E0	DUCT	1				
23	97702-50516	SCREW, TAPPING	2				
24	5UM-1443A-E0	DUCT	1				
25	5UM-14417-E0	COVER 1	1				
26	97702-50516	SCREW, TAPPING	3				
27	5BF-1443E-00	PIPE, DRAIN	1				

**FIG. 9 INTAKE**



5UME100-F090

REF. NO.	PART NO.	DESCRIPTION	SUMM				REMARKS
28	90467-17089	CLIP	1				
29	5UM-14462-E0	SEAL	1				
30	97702-50516	SCREW, TAPPING	1				
31	5TJ-14419-00	PIPE	1				
32	5UM-1441A-E0	COVER, CLEANER CASE 1	1				
33	3FV-28386-00	HEAD	1				
34	2TK-21757-00	WASHER, SPECIAL 1	1				
35	5TJ-21757-00	WASHER, SPECIAL 1	1				
36	90249-05005	PIN	1				
37	90249-05004	PIN	1				
38	99002-04600	CIRCLIP	2				
39	90109-06245	BOLT	2				



5UME100-F100

FIG. 10 CARBURETOR

REF. NO.	PART NO.	DESCRIPTION	SUMM			REMARKS
1	5UM-14101-E0	CARBURETOR ASSY 1	1			
2	5JG-14959-00	.GASKET	1			
3	91316-04012	.BOLT	6			
4	688-14592-00	.SCREW	3			
5	90202-08045	.WASHER, PLATE	1			
6	5JG-14951-00	.WASHER	1			
7	5JG-14522-00	.SCREW, ADJUST	1			
8	2S2-14388-00	.VALVE, VACUUM CONTROL	1			
9	3TJ-14267-40	.ROLLER	1			
10	5JG-14546-01	.VALVE, NEEDLE	1			
11	4FN-14997-00	.SEAL	1			
12	5UM-14916-RU	.NEEDLE (NJRU)	1			STD
	5UM-14916-BN	.NEEDLE (GDEPN)	1			AP
	5UM-14916-BP	.NEEDLE (GDEPP)	1			AP
	5UM-14916-B1	.NEEDLE (GDEPQ)	1			AP
	5UM-14916-BR	.NEEDLE (GDEPR)	1			AP
	5UM-14916-BS	.NEEDLE (GDEPS)	1			AP
	5UM-14916-BT	.NEEDLE (GDEPT)	1			AP
	5UM-14916-BU	.NEEDLE (GDEPU)	1			AP
	5UM-14916-BV	.NEEDLE (GDEPV)	1			AP
13	3TJ-14159-40	.CLIP	1			
14	5JG-14521-00	.SCREW, ADJUST	1			
15	5JG-14275-00	.SPRING	1			
16	5JG-14264-00	.COLLAR	1			
17	5TJ-14947-00	.JET, NEEDLE	1			
18	4MX-14943-41	.JET, MAIN (#170)	1			STD
	4MX-14943-89	.JET, MAIN (#158)	1			AP

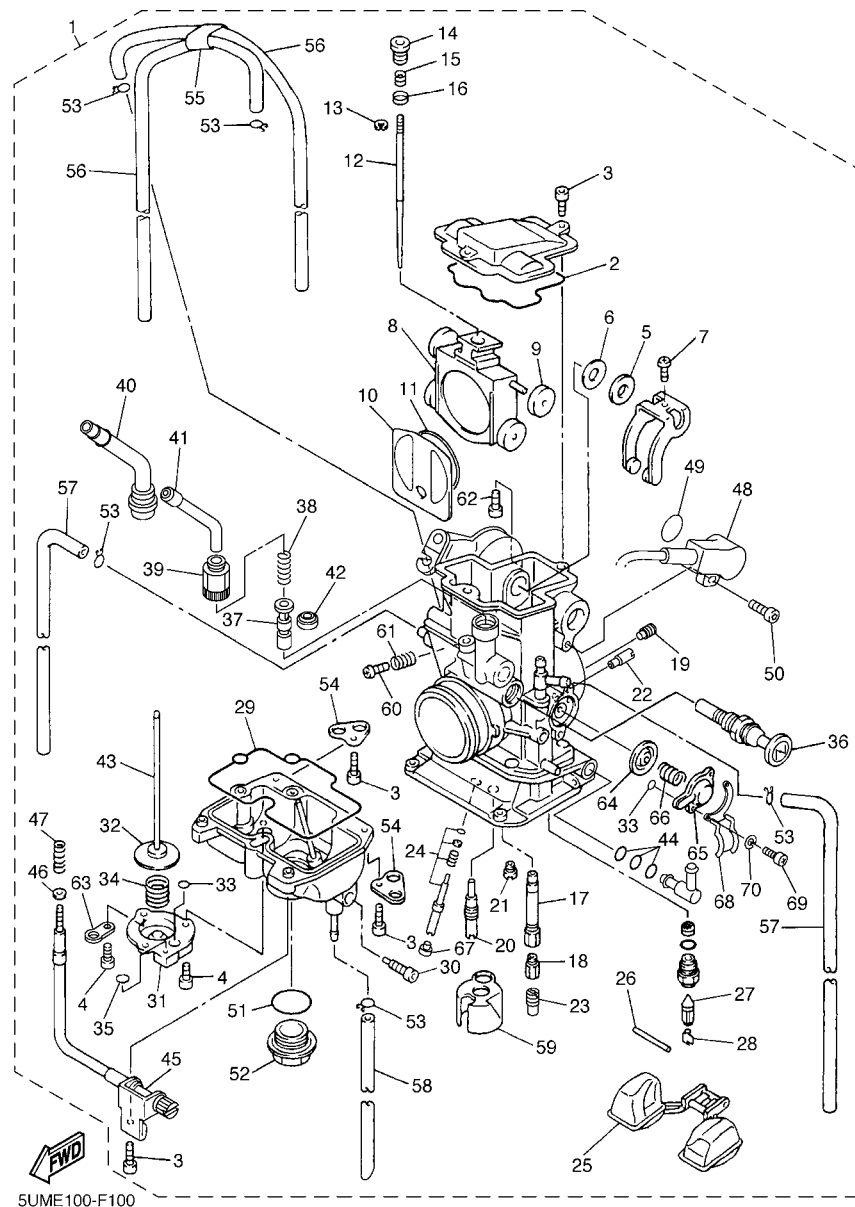
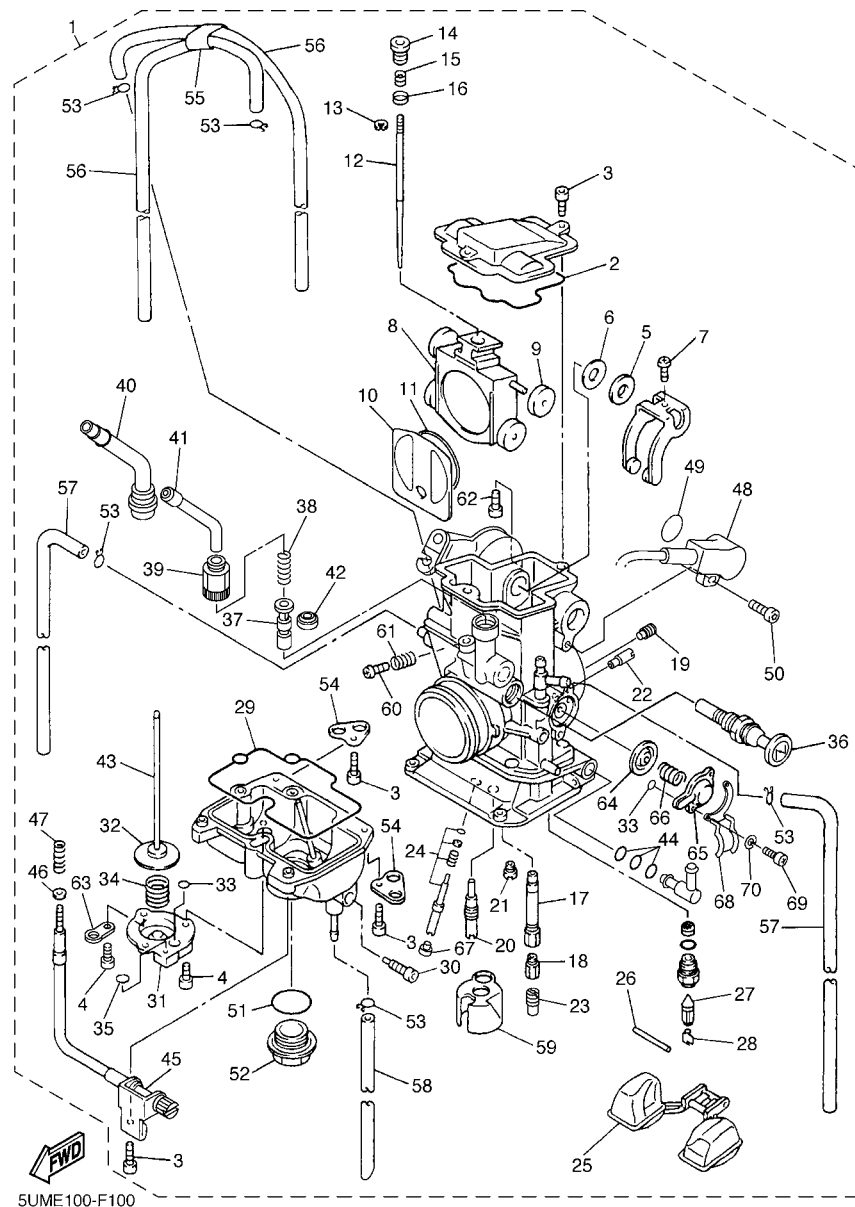


FIG. 10 CARBURETOR

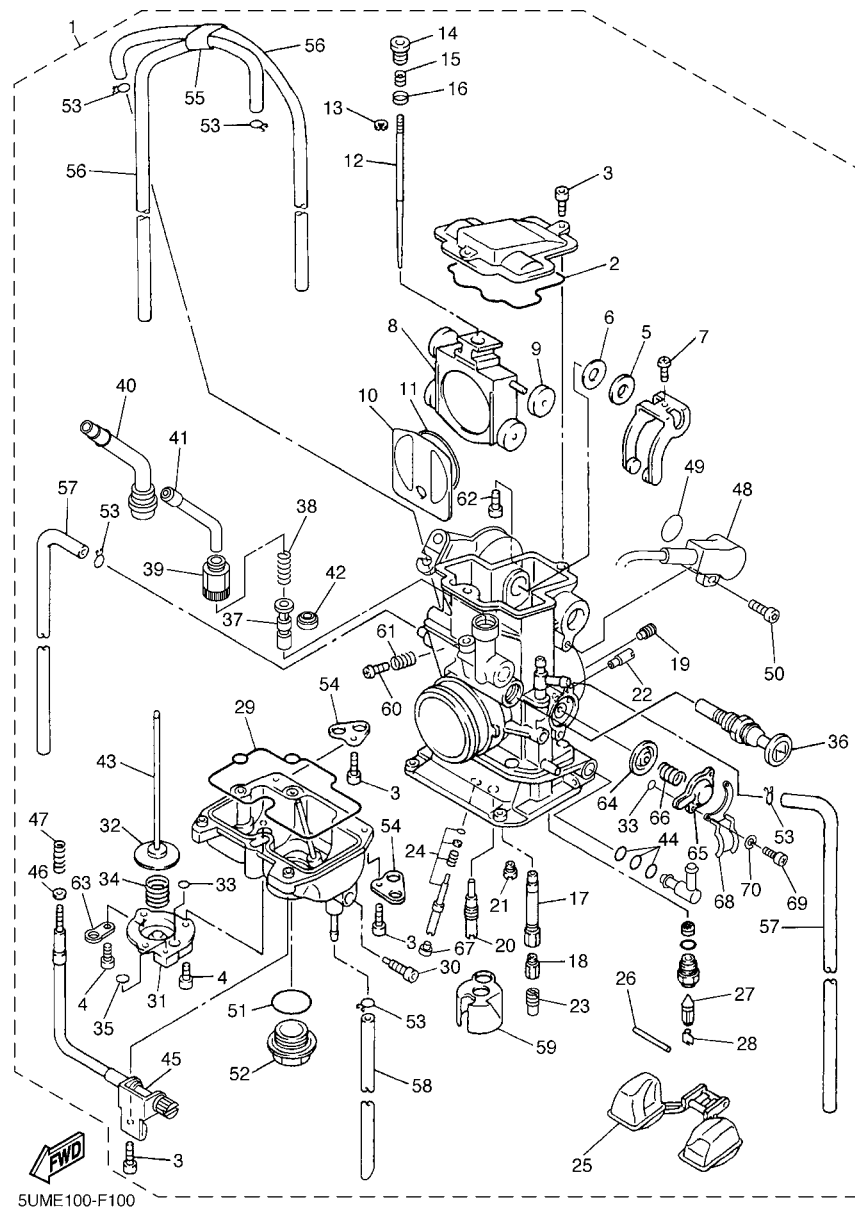
REF. NO.	PART NO.	DESCRIPTION	SUMM			REMARKS
18	4MX-14943-39	.JET, MAIN (#160)	1			AP
	4MX-14943-90	.JET, MAIN (#162)	1			AP
	4MX-14943-40	.JET, MAIN (#165)	1			AP
	4MX-14943-91	.JET, MAIN (#168)	1			AP
	4MX-14943-92	.JET, MAIN (#172)	1			AP
	4MX-14943-42	.JET, MAIN (#175)	1			AP
	4MX-14943-93	.JET, MAIN (#178)	1			AP
	4MX-14943-43	.JET, MAIN (#180)	1			AP
	4MX-14943-94	.JET, MAIN (#182)	1			AP
19	5UM-1494F-30	.JET (#115)	1			
20	4MX-14948-04	.JET, SLOW (#42)	1			STD
	4MX-14948-03	.JET, SLOW (#40)	1			AP
	4MX-14948-05	.JET, SLOW (#45)	1			AP
	4MX-14948-06	.JET, SLOW (#48)	1			AP
	4MX-14948-07	.JET, SLOW (#50)	1			AP
21	3TJ-1494F-14	.JET (#68)	1			STD
	3TJ-1494F-12	.JET (#62)	1			AP
	3TJ-1494F-13	.JET (#65)	1			AP
	3TJ-1494F-15	.JET (#70)	1			AP
	3TJ-1494F-16	.JET (#72)	1			AP
22	5TA-14943-15	.JET, MAIN (#70)	1			
23	4JT-1494F-15	.JET (#70)	1			STD
	4JT-1494F-11	.JET (#60)	1			AP
	4JT-1494F-19	.JET (#80)	1			AP
	4JT-1494F-23	.JET (#90)	1			AP
	4JT-1494F-27	.JET(#100)	1			AP
	4JT-1494F-29	.JET(#110)	1			AP



5UME100-F100

FIG. 10 CARBURETOR

REF. NO.	PART NO.	DESCRIPTION	SUMM			REMARKS
23	4JT-1494F-31	.JET(#120)	1			AP
24	5NL-14105-00	.PILOT SCREW SET	1			
25	4SR-14985-00	.FLOAT	1			
26	676-14548-00	.PIN, FLOAT ARM	1			
27	4MX-14392-00	.VALVE, NEEDLE	1			
28	633-14159-00	.CLIP	1			
29	5JG-14984-00	.GASKET, FLOAT CHAMBER	1			
30	3TJ-14191-40	.PLUG, DRAIN	1			
31	3TJ-14293-40	.COVER 1	1			
32	5JG-14940-76	.DIAPHRAGM ASSY	1			STD
	5JG-14940-16	.DIAPHRAGM ASSY	1			AP
	5JG-14940-17	.DIAPHRAGM ASSY	1			AP
	5JG-14940-18	.DIAPHRAGM ASSY	1			AP
33	3TJ-14536-40	.GASKET	2			
34	3TJ-14933-40	.SPRING, DIAPHRAGM	1			
35	6H4-14561-00	.O-RING	1			
36	5XC-14171-00	.PLUNGER, STARTER	1			
37	5TA-14371-00	.PLUNGER, STARTER	1			
38	5TA-14335-00	.SPRING, PLUNGER	1			
39	5TA-14991-00	.SCREW	1			
40	2S2-14374-00	.CAP, PLUNGER	1			
41	5TA-14155-00	.GUIDE, CABLE	1			
42	5TA-14997-00	.SEAL	1			
43	5JG-14379-00	.ROD, STARTER	1			
44	3TJ-14564-40	.O-RING	3			
45	5XC-14922-00	.SCREW, THROTTLE	1			
46	90201-08410	.WASHER, PLATE	1			

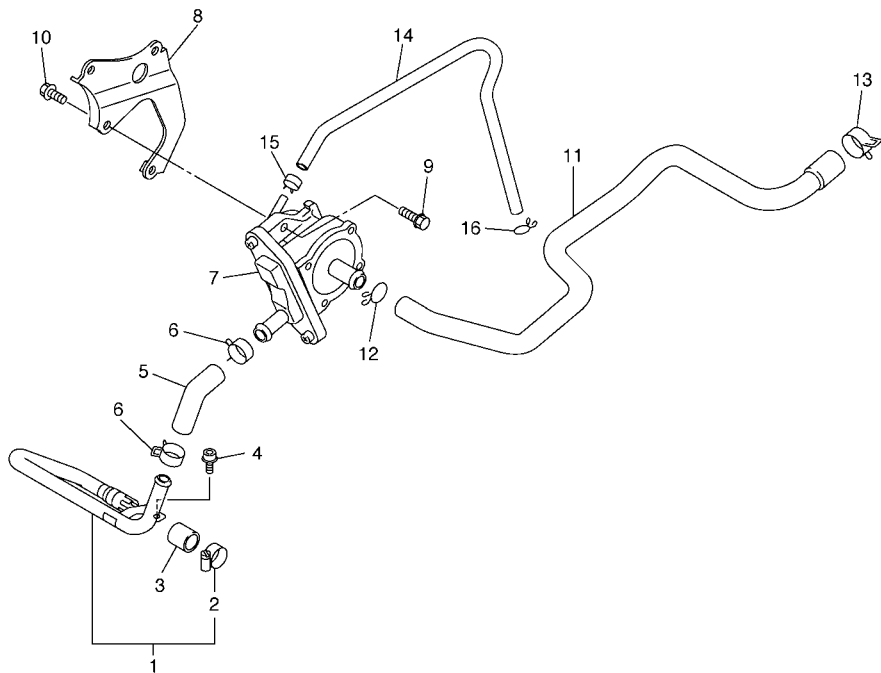


5UME100-F100

FIG. 10 CARBURETOR

REF. NO.	PART NO.	DESCRIPTION	SUMM				REMARKS
47	5TA-14934-00	.SPRING, THROTTLE STOP	1				
48	5XC-85885-00	.THROTTLE SENSOR ASSY	1				
49	5NX-14562-00	.O-RING	1				
50	5NX-14216-00	.SCREW	1				
51	4MX-14561-00	.O-RING	1				
52	4MX-14115-00	.PLUG, SCREW	1				
53	3TJ-14137-40	.CLIP	5				
54	5BE-14146-00	.PLATE	2				
55	5TA-14261-00	.HOLDER	1				
56	5UL-14196-00	.PIPE	2				
57	5TA-14197-00	.PIPE	2				
58	5TJ-14987-00	.HOSE	1				
59	5JG-14346-00	.PLATE	1				
60	5JG-14565-00	.SCREW	1				
61	5JG-14531-00	.SPRING, ADJUST SCREW	1				
62	5GS-14591-00	.SCREW	1				
63	5PA-14146-00	.PLATE	1				
64	5GS-14940-00	.DIAPHRAGM ASSY	1				
65	5GS-14958-00	.COVER, DIAPHRAGM	1				
66	5GS-14933-00	.SPRING, DIAPHRAGM	1				
67	5TJ-14118-00	.CAP	1				
68	5TJ-14243-00	.PLATE	1				
69	98502-04010	.SCREW, PAN HEAD	2				
70	92902-04100	.WASHER, SPRING	2				

**FIG. 11 AIR INDUCTION SYSTEM**

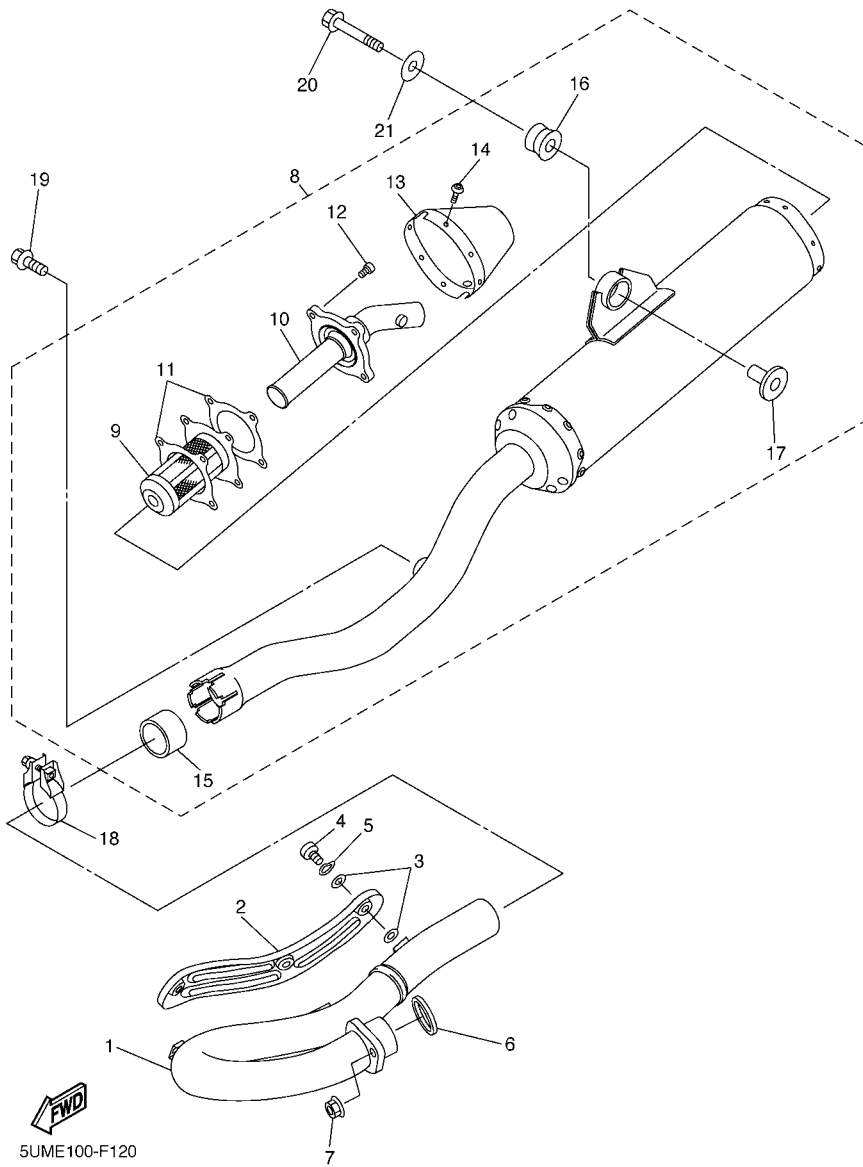


REF. NO.	PART NO.	DESCRIPTION	SUMM				REMARKS
1	5UM-14871-10	PIPE 1	1				
2	90450-20078	.HOSE CLAMP ASSY	1				
3	4KM-14714-01	GASKET, MUFFLER	1				
4	90109-060E9	BOLT	1				
5	5UM-14881-00	HOSE, BEND 1	1				
6	90467-16063	CLIP	2				
7	5UM-14803-00	AIR INDUCTION SYSTEM ASSY	1				
8	5UM-14834-E0	STAY	1				
9	90105-06107	BOLT, FLANGE	2				
10	90105-06105	BOLT, FLANGE	2				
11	5UM-14882-00	HOSE, BEND 2	1				
12	90467-140A4	CLIP	1				
13	90467-17089	CLIP	1				
14	90445-08027	HOSE	1				
15	90467-07138	CLIP	1				
16	90467-09006	CLIP	1				



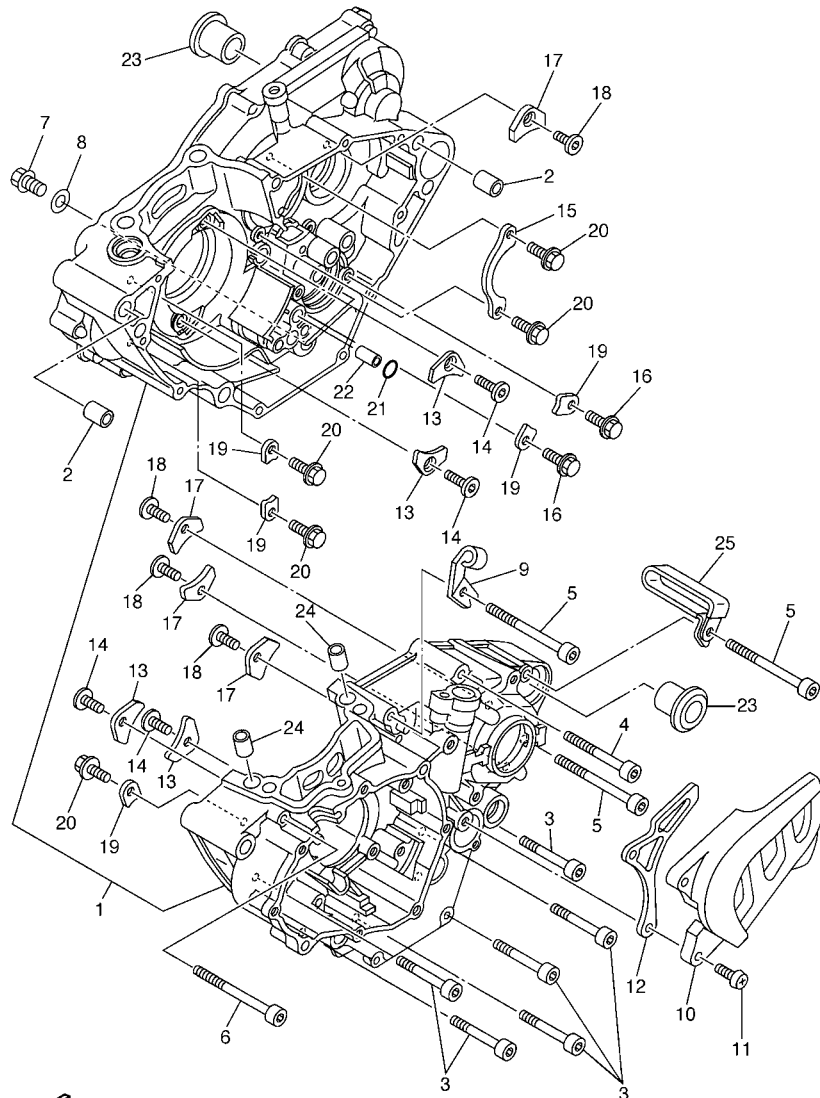
5UME100-F110





**FIG. 12 EXHAUST**

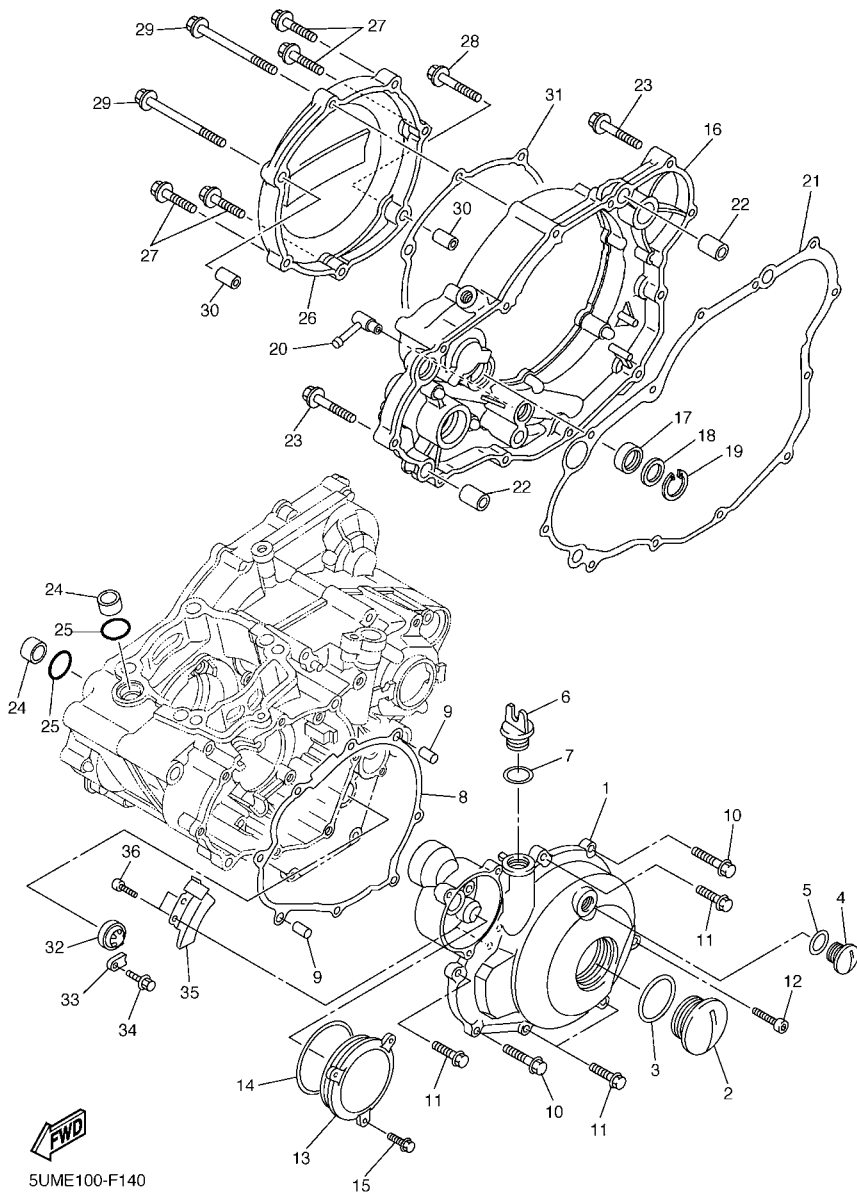
REF. NO.	PART NO.	DESCRIPTION	SUMM				REMARKS
1	5UM-14611-10	PIPE, EXHAUST 1	1				
2	5XC-14628-00	PROTECTOR, EXHAUST PIPE	1				
3	4BD-14766-00	WASHER, PROTECTOR	6				
4	98980-06008	SCREW, BIND	3				
5	90206-06090	WASHER, WAVE	3				
6	5NL-14613-00	GASKET, EXHAUST PIPE	1				
7	95702-08500	NUT, WITH WASHER	2				
8	5UM-14710-E0	MUFFLER ASSY 1	1				
9	5TJ-14780-00	.SPARK ARRESTER ASSY	1				
10	5TJ-14784-00	.PIPE, TAIL	1				
11	5TJ-14623-00	.GASKET, EXHAUST PIPE	2				
12	90110-05041	.BOLT, HEXAGON SOCKET HEAD	4				
13	5TJ-14799-00	.CAP	1				
14	92012-05008	.BOLT, BUTTON HEAD	6				
15	5PH-14714-00	.GASKET, MUFFLER	1				
16	5BE-14747-00	.DAMPER, MUFFLER	1				
17	90387-08081	.COLLAR	1				
18	5BE-14788-00	BAND, SILENCER	1				
19	90105-08307	BOLT, FLANGE	1				
20	90105-08137	BOLT, FLANGE	1				
21	90201-08061	WASHER, PLATE	1				



**FWD**  
5UME100-F130

**FIG. 13 CRANKCASE**

REF. NO.	PART NO.	DESCRIPTION	SUMM				REMARKS
1	5UM-15150-20-YX	CRANKCASE ASSY	1				
2	93612-16254	PIN, DOWEL	2				
3	91312-06045	BOLT	5				
4	91312-06055	BOLT	1				
5	91312-06070	BOLT	3				
6	91312-06100	BOLT	1				
7	95022-10016	BOLT, FLANGE	1				
8	90430-10188	GASKET	1				
9	5NL-15441-01	HOLDER, CLUTCH CABLE	1				
10	5BE-15421-30	COVER, CRANKCASE 2	1				
11	98502-06025	SCREW, PAN HEAD	2				
12	5NL-17466-00	GUIDE, CHAIN	1				
13	5BE-15383-01	PLATE, BEARING COVER	4				
14	90151-06044	SCREW, COUNTERSUNK	4				
15	5NL-15388-00	PLATE, BEARING COVER	1				
16	90105-06081	BOLT, FLANGE	2				
17	4JT-15381-01	PLATE, BEARING COVER	4				
18	90149-06074	SCREW	4				
19	5DH-18562-00	PLATE, STOPPER 2	5				
20	90105-06081	BOLT, FLANGE	5				
21	93210-10197	O-RING	1				
22	99530-10114	PIN, DOWEL	1				
23	90387-18007	COLLAR	2				
24	99530-10116	PIN, DOWEL	2				
25	90465-10013	CLAMP	1				

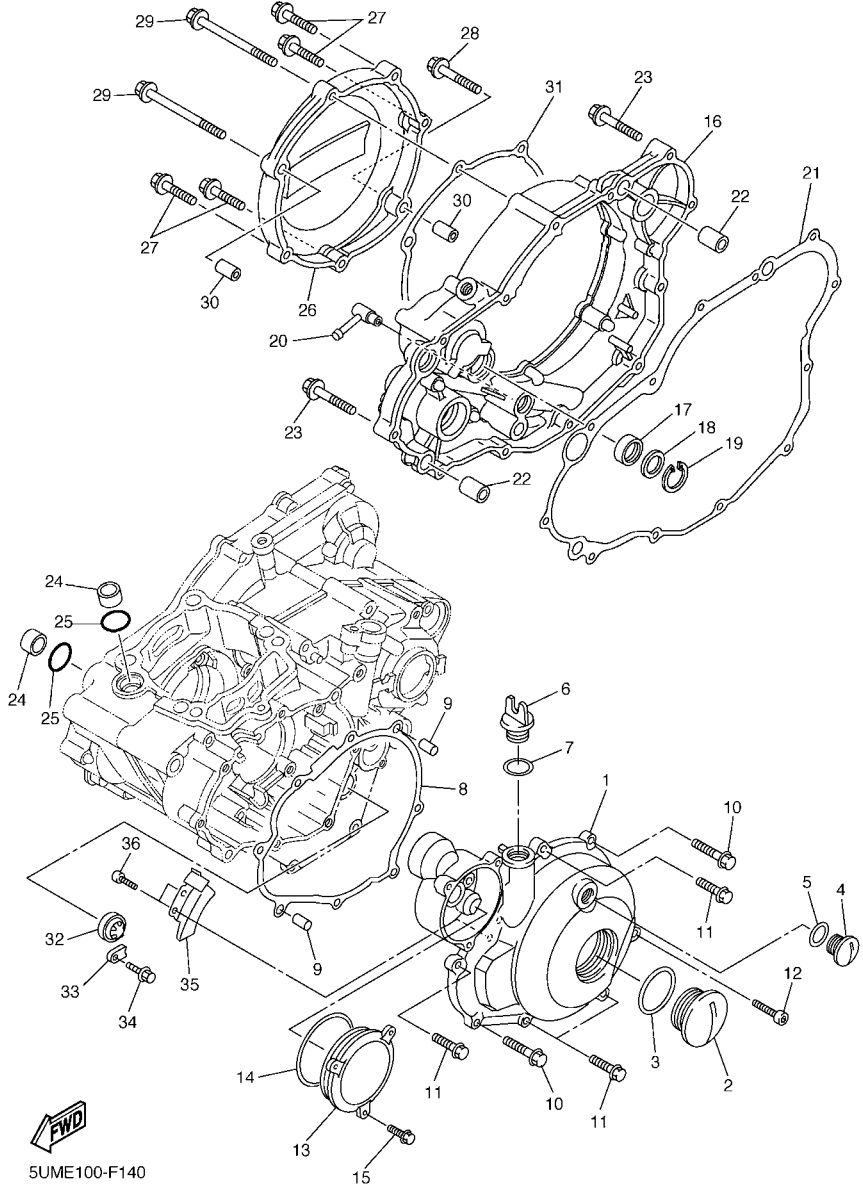


SUME100-F140

FIG. 14 CRANKCASE COVER 1

REF. NO.	PART NO.	DESCRIPTION	SUMM				REMARKS
1	5UM-15411-20	COVER, CRANKCASE 1	1				
2	90340-27004	PLUG, STRAIGHT SCREW	1				
3	93210-27370	O-RING	1				
4	90340-14015	PLUG, STRAIGHT SCREW	1				
5	93210-14369	O-RING	1				
6	3Y1-15363-00	PLUG, OIL	1				
7	93210-19123	O-RING	1				
8	5UM-15451-00	GASKET, CRANKCASE COVER 1	1				
9	99530-08016	PIN, DOWEL	2				
10	95022-06040	BOLT, FLANGE	2				
11	95022-06030	BOLT, FLANGE	4				
12	91312-06110	BOLT	1				
13	5UM-1549B-20	COVER ASSY 2	1				
14	93210-60426	O-RING	1				
15	95022-06016	BOLT, FLANGE	3				
16	5XC-15431-01	COVER, CRANKCASE 3	1				
17	93101-14164	OIL SEAL	1				
18	90201-15701	WASHER, PLATE (T=1.0)	1				
19	99009-22500	CIRCLIP	1				
20	5XC-15373-00	PIPE, BREATHER	1				
21	5NL-15462-00	GASKET, CRANKCASE COVER 3	1				
22	91812-16001	PIN, DOWEL	2				
23	95022-06035	BOLT, FLANGE	8				
24	5NL-12564-00	PIPE, WATER	2				
25	93210-16716	O-RING	2				
26	5NL-15415-30	COVER, GENERATOR	1				
27	95022-06025	BOLT, FLANGE	4				

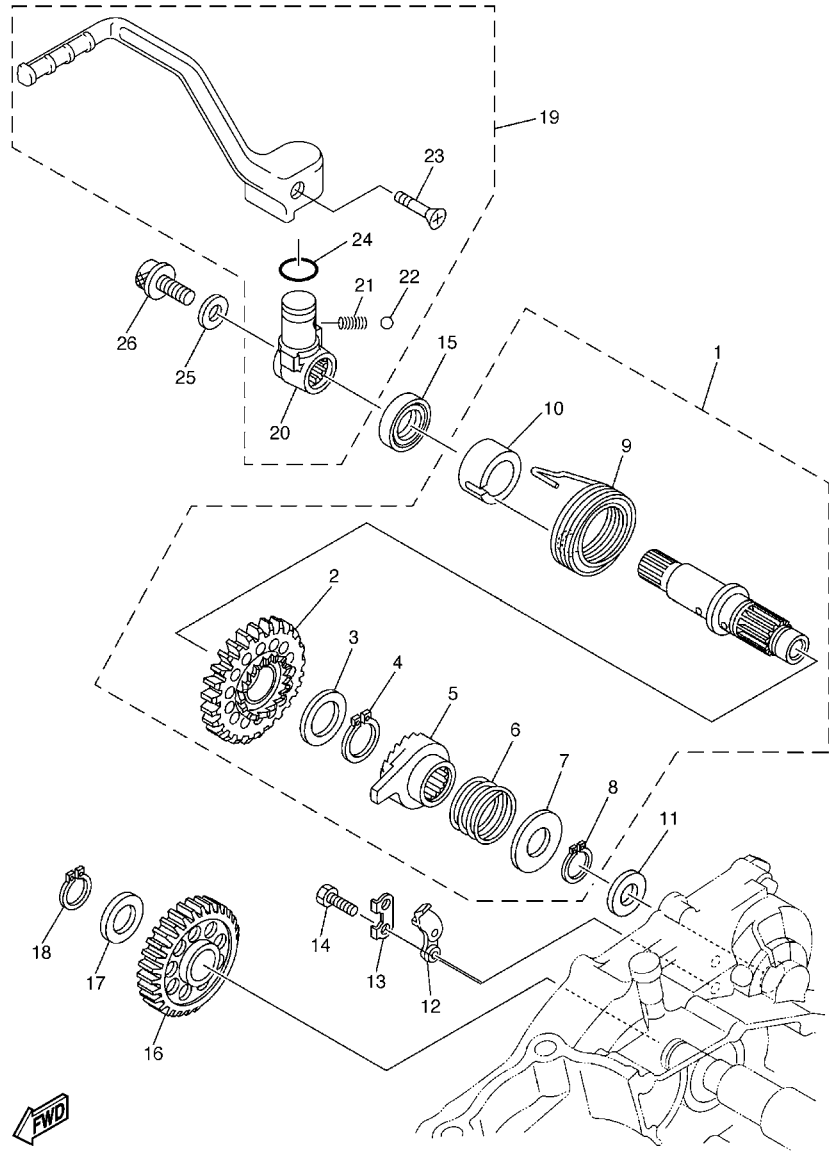
**FIG. 14 CRANKCASE COVER 1**



SUME100-F140

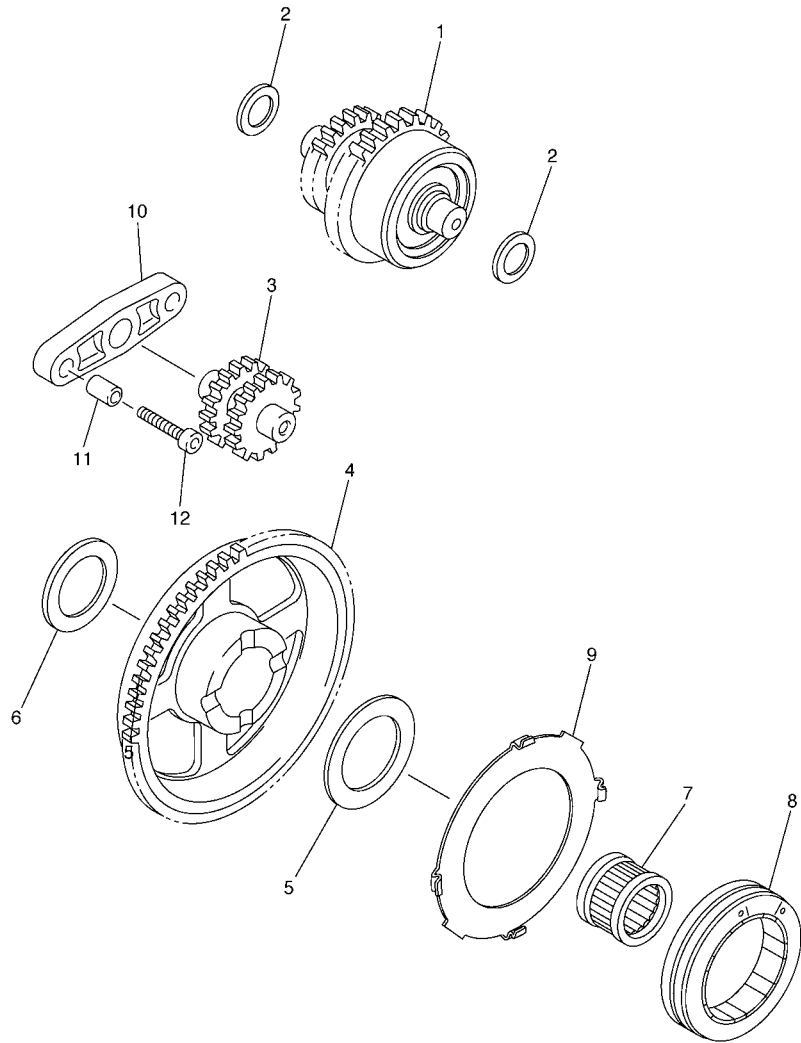
REF. NO.	PART NO.	DESCRIPTION	SUMM				REMARKS
28	95022-06035	BOLT, FLANGE	1				
29	90105-06098	BOLT, FLANGE	2				
30	99530-08016	PIN, DOWEL	2				
31	5NL-15453-10	GASKET	1				
32	3Y1-15361-00	GAUGE, LEVEL	1				
33	5XC-15118-00	HOLDER	1				
34	90105-06094	BOLT, FLANGE	1				
35	5UM-81528-00	CLAMP 1	1				
36	91312-05012	BOLT	2				
-----							
-----							
-----							
-----							
-----							
-----							
-----							
-----							
-----							
-----							
-----							

FIG. 15 STARTER



  
SUME100-F150

REF. NO.	PART NO.	DESCRIPTION	SUMMM				REMARKS
1	5NL-15601-20	KICK SHAFT ASSY	1				
2	5NL-15641-20	.GEAR, KICK	1				
3	90201-20685	.WASHER, PLATE (T=0.5)	1				
4	93410-20038	.CIRCLIP	1				
5	2S2-15671-00	.WHEEL, RATCHET	1				
6	90501-160A2	.SPRING, COMPRESSION	1				
7	90201-167P7	.WASHER, PLATE	1				
8	99009-16400	.CIRCLIP	1				
9	90508-30743	.SPRING, TORSION	1				
10	5NL-15664-00	.GUIDE, SPRING	1				
11	90201-162H4	WASHER, PLATE	1				
12	5SG-15668-00	STOPPER	1				
13	214-15686-00	WASHER, LOCK	1				
14	90101-06044	BOLT	2				
15	93102-18278	OIL SEAL	1				
16	5NL-15651-00	GEAR, KICK IDLE	1				
17	90201-177G4	WASHER, PLATE	1				
18	99009-17400	CIRCLIP	1				
19	5XC-15620-10	KICK CRANK ASSY	1				
20	5XC-15621-10	.BOSS, KICK CRANK	1				
21	90501-147A5	.SPRING, COMPRESSION	1				
22	93507-32009	.BALL	1				
23	90152-06010	.SCREW, COUNTERSUNK	1				
24	93210-17570	.O-RING	1				
25	90201-08048	WASHER, PLATE	1				
26	90110-08051	BOLT, HEXAGON SOCKET HEAD	1				

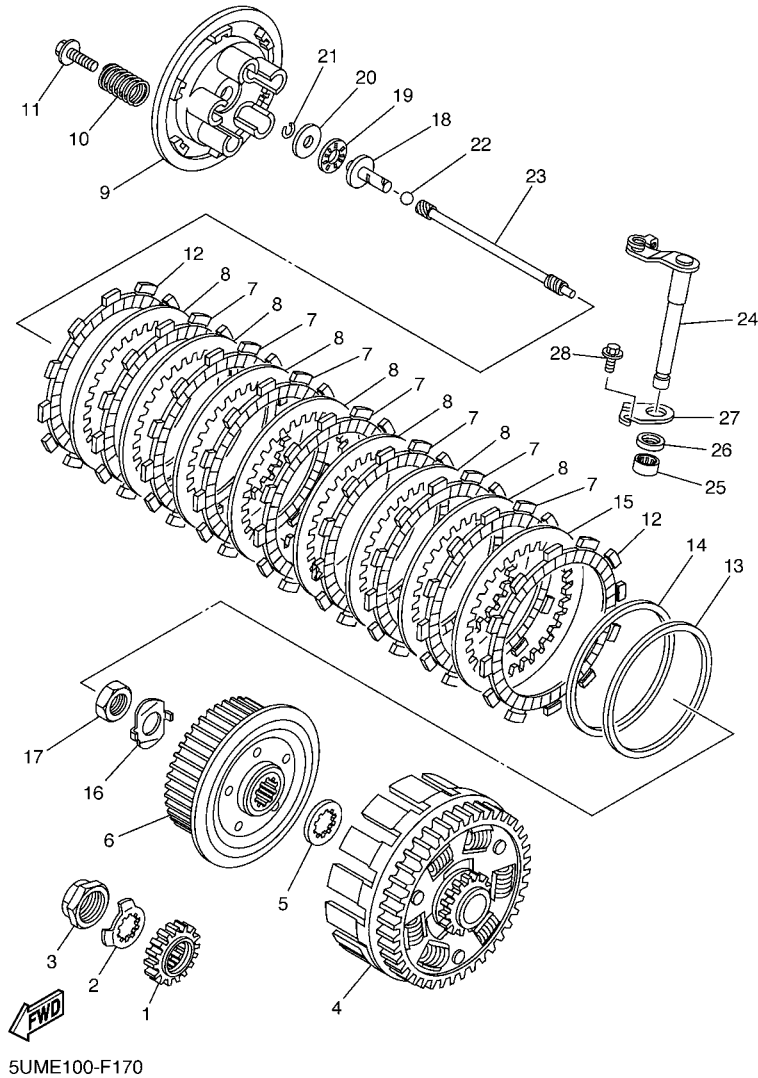


**FIG. 16 STARTER CLUTCH**

REF. NO.	PART NO.	DESCRIPTION	SUMM				REMARKS
1	5UM-15560-10	DAMPER ASSY	1				
2	90201-104R2	WASHER, PLATE	2				
3	5UM-15517-00	GEAR, IDLER 2	1				
4	5UM-15515-20	GEAR 3	1				
5	90201-20021	WASHER, PLATE (T=1.0)	1				
6	90201-203L1	WASHER, PLATE	1				
7	93310-42057	BEARING	1				
8	5UM-15570-00	STARTER CLUTCH ASSY	1				
9	5VY-15586-00	PLATE, STARTER CLUTCH ASSY	1				
10	5UM-15532-00	PLATE, IDLE GEAR	1				
11	99530-08012	PIN, DOWEL	2				
12	91312-06025	BOLT	2				



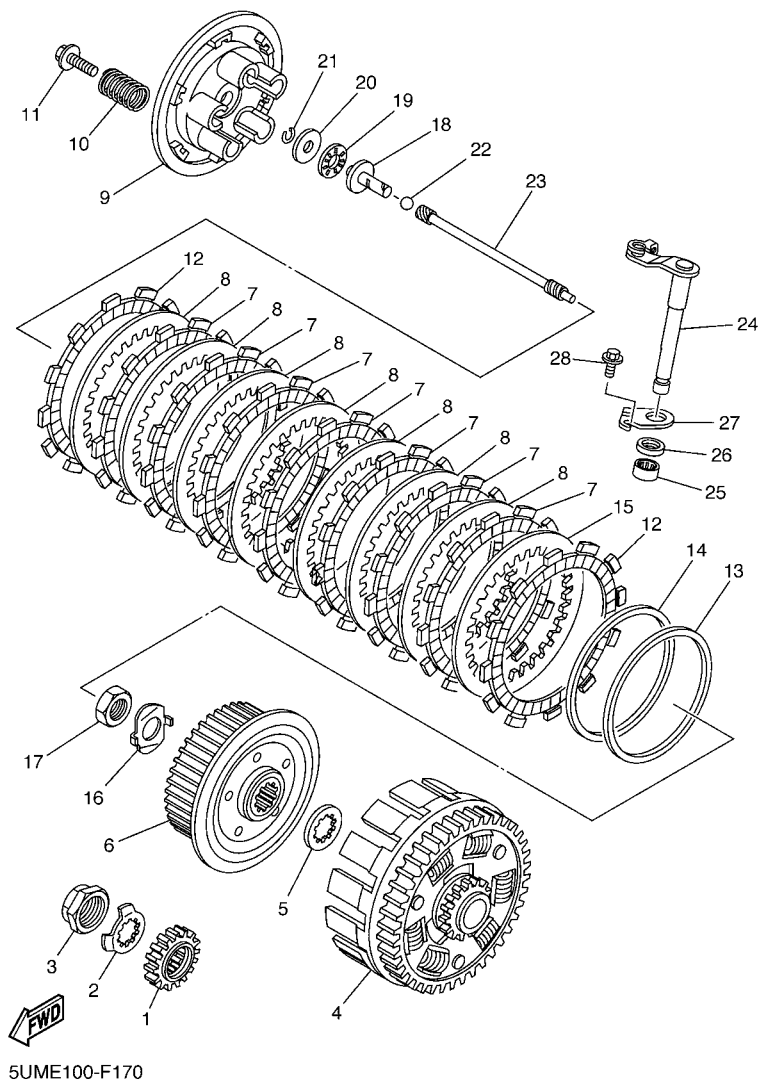
5UMB100-E160



**FIG. 17 CLUTCH**

REF. NO.	PART NO.	DESCRIPTION	SUMM				REMARKS
1	5NL-16111-01	GEAR, PRIMARY DRIVE	1				
2	90215-20003	WASHER, LOCK	1				
3	90179-18001	NUT	1				
4	5NL-16150-10	PRIMARY DRIVEN GEAR COMP.	1				
5	5NL-16154-00	PLATE, THRUST 1	1				
6	5NL-16371-00	BOSS, CLUTCH	1				
7	5DH-16321-00	PLATE, FRICTION	7				
8	5NL-16325-00	PLATE, CLUTCH 2	7				
9	5HD-16351-00	PLATE, PRESSURE 1	1				
10	90501-220A0	SPRING, COMPRESSION	5				
11	90159-06092	SCREW, WITH WASHER	5				
12	3XJ-16321-00	PLATE, FRICTION	2				
13	5NL-16384-00	PLATE, SEAT	1				
14	5NL-16383-10	SPRING, CLUTCH BOSS	1				
15	5NL-16325-10	PLATE, CLUTCH 2	1				
16	90215-16289	WASHER, LOCK	1				
17	90170-16326	NUT	1				
18	5XC-16356-00	ROD, PUSH 1	1				
19	93340-21008	BEARING	1				
20	90201-080H1	WASHER, PLATE	1				
21	93440-07182	CIRCLIP	1				
22	93511-32027	BALL	1				
23	5NL-16357-10	ROD, PUSH 2	1				
24	5JG-16381-10	PUSH LEVER COMP.	1				
25	93317-11287	BEARING	1				
26	93102-12224	OIL SEAL	1				
27	4JT-16384-00	PLATE, SEAT	1				

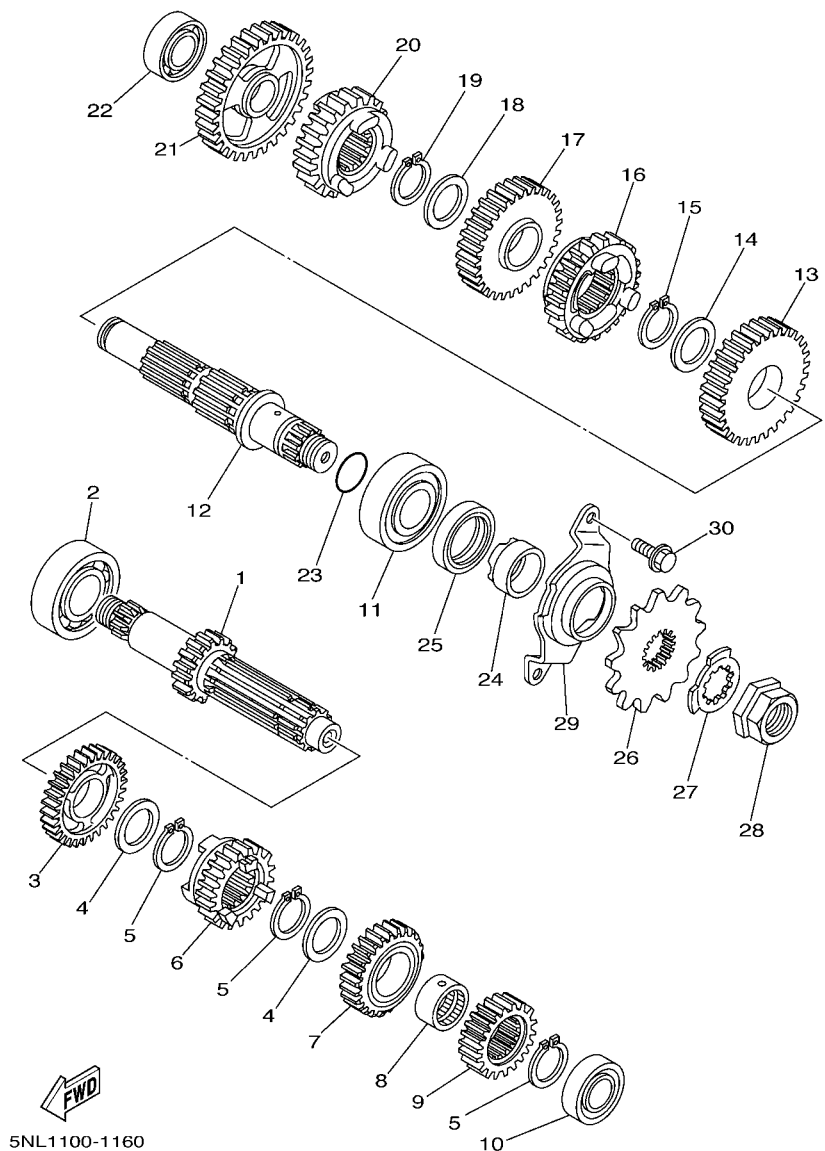
FIG. 17 CLUTCH



REF. NO.	PART NO.	DESCRIPTION	SUMM			REMARKS
28	95022-06010	BOLT, FLANGE	1			



FIG. 18 TRANSMISSION



REF. NO.	PART NO.	DESCRIPTION	SUMM				REMARKS
1	5UM-17411-00	AXLE, MAIN (13T)	1				
2	93306-20447	BEARING	1				
3	5UM-17151-00	GEAR,5TH PINION (19T)	1				
4	90209-20008	WASHER	2				
5	93410-22039	CIRCLIP	3				
6	5UM-17131-00	GEAR,3RD PINION (17T)	1				
7	5UM-17141-00	GEAR, 4TH PINION (21T)	1				
8	90387-20006	COLLAR	1				
9	5NL-17121-00	GEAR, 2ND PINION (16T)	1				
10	93306-00320	BEARING	1				
11	93306-27208	BEARING	1				
12	5NL-17402-00	DRIVE AXLE ASSY	1				
13	5NL-17221-00	GEAR, 2ND WHEEL (28T)	1				
14	90209-23012	WASHER	1				
15	93410-26067	CIRCLIP	1				
16	5UM-17241-00	GEAR, 4TH WHEEL (23T)	1				
17	5UM-17231-00	GEAR,3RD WHEEL (23T)	1				
18	90209-20008	WASHER	1				
19	93410-22039	CIRCLIP	1				
20	5UM-17251-00	GEAR,5TH WHEEL (17T)	1				
21	5PH-17211-00	GEAR,1ST WHEEL (31T)	1				
22	93306-00317	BEARING	1				
23	93210-196A4	O-RING	1				
24	90387-22001	COLLAR	1				
25	93102-28010	OIL SEAL	1				
26	9383B-13218	SPROCKET, DRIVE (13T)	1				STD
	9383B-14222	SPROCKET, DRIVE (14T)	1				AP FOR OCE

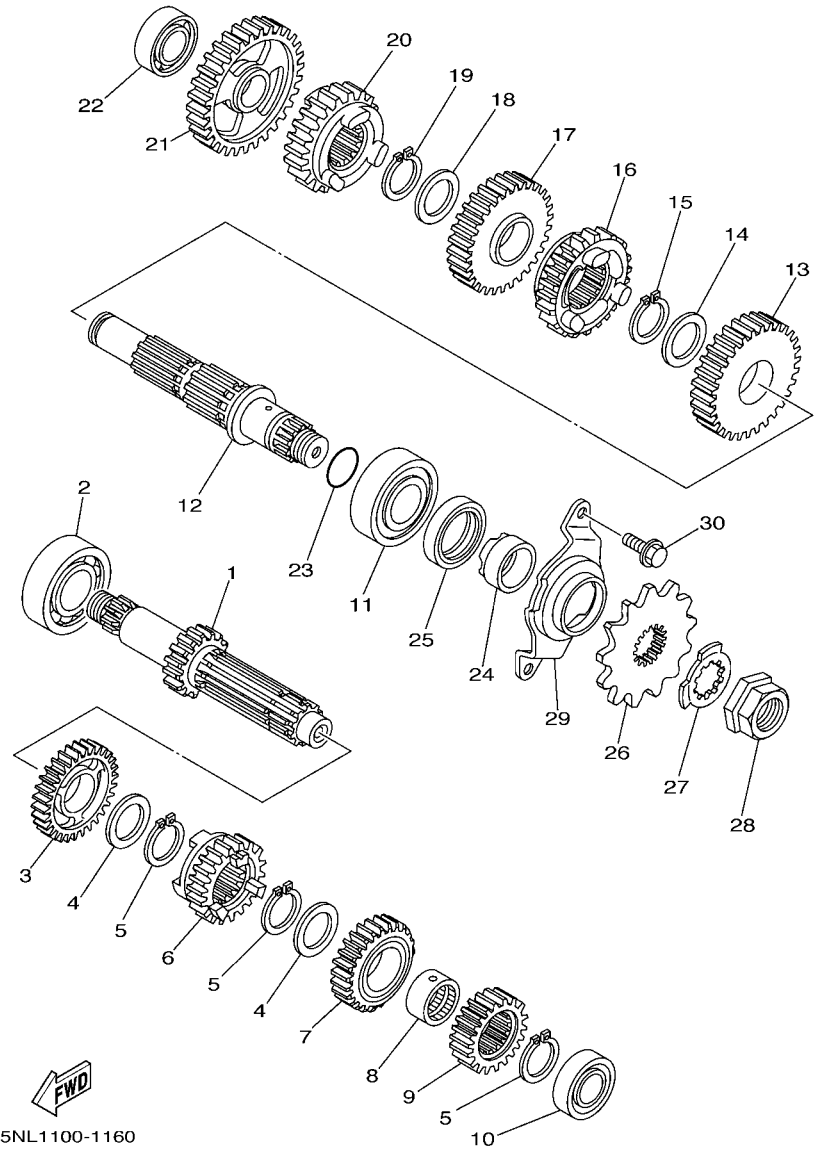
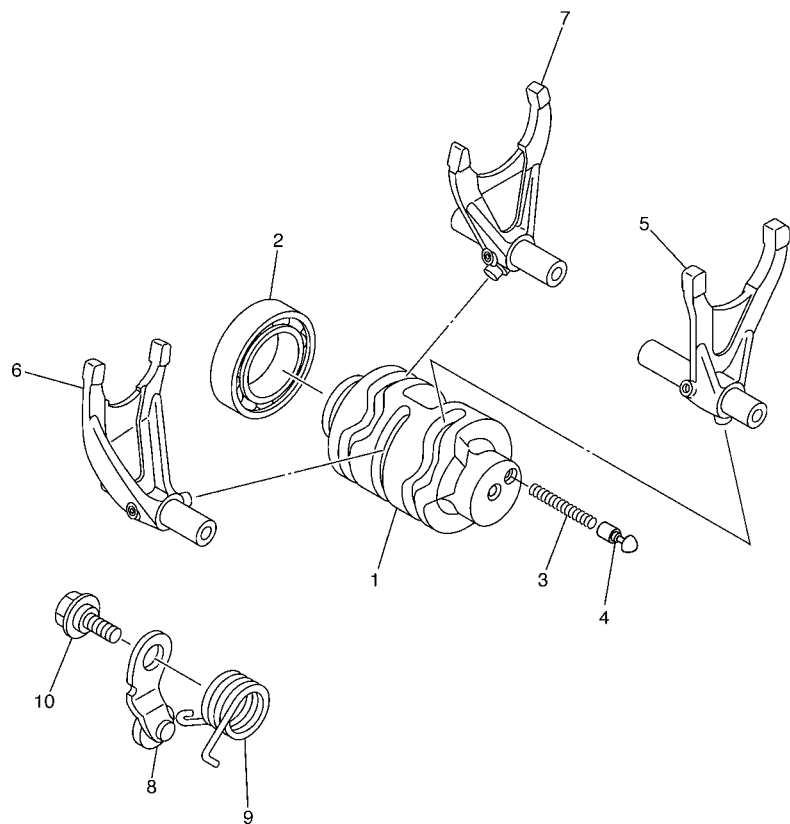


FIG. 18 TRANSMISSION

REF. NO.	PART NO.	DESCRIPTION	SUMM				REMARKS
27	90215-20003	WASHER, LOCK	1				
28	90179-18001	NUT	1				
29	5NL-17471-10	PLATE, COVER	1				
30	90105-06081	BOLT, FLANGE	2				
-----							
-----							
-----							
-----							
-----							
-----							

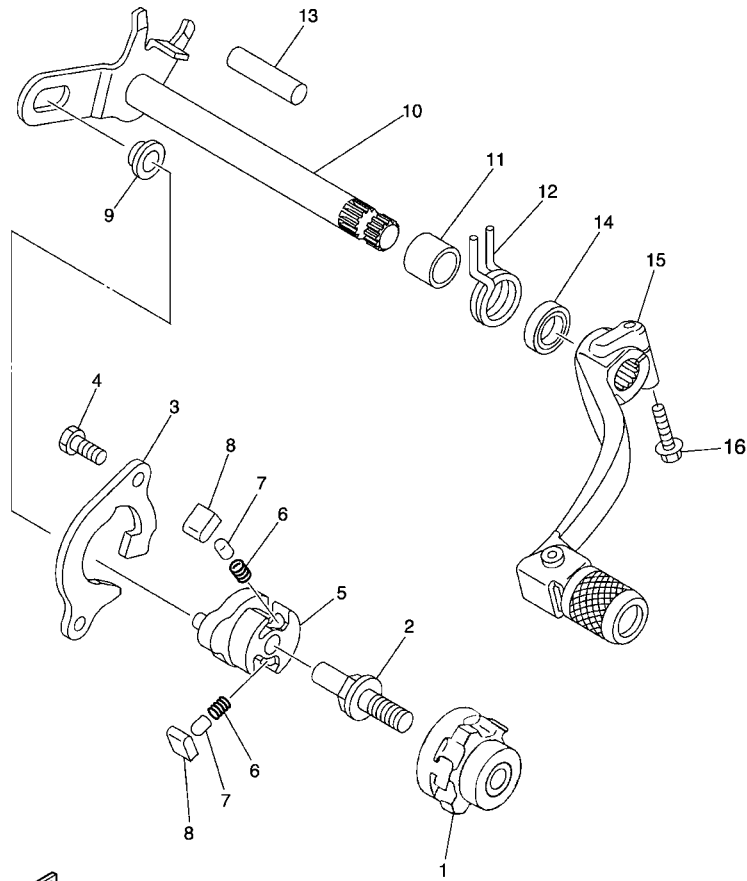
**FIG. 19 SHIFT CAM & FORK**



REF. NO.	PART NO.	DESCRIPTION	SUMM				REMARKS
1	5NL-18541-00	CAM, SHIFT	1				
2	93306-90509	BEARING	1				
3	90501-06022	SPRING, COMPRESSION	1				
4	4UN-18542-00	POINT, NEUTRAL	1				
5	5NL-18501-00	FORK, SHIFT 1	1				
6	5NL-18502-00	FORK, SHIFT 2	1				
7	5NL-18503-00	FORK, SHIFT 3	1				
8	3XK-18140-00	STOPPER LEVER ASSY	1				
9	90508-26561	SPRING, TORSION	1				
10	90109-06193	BOLT	1				

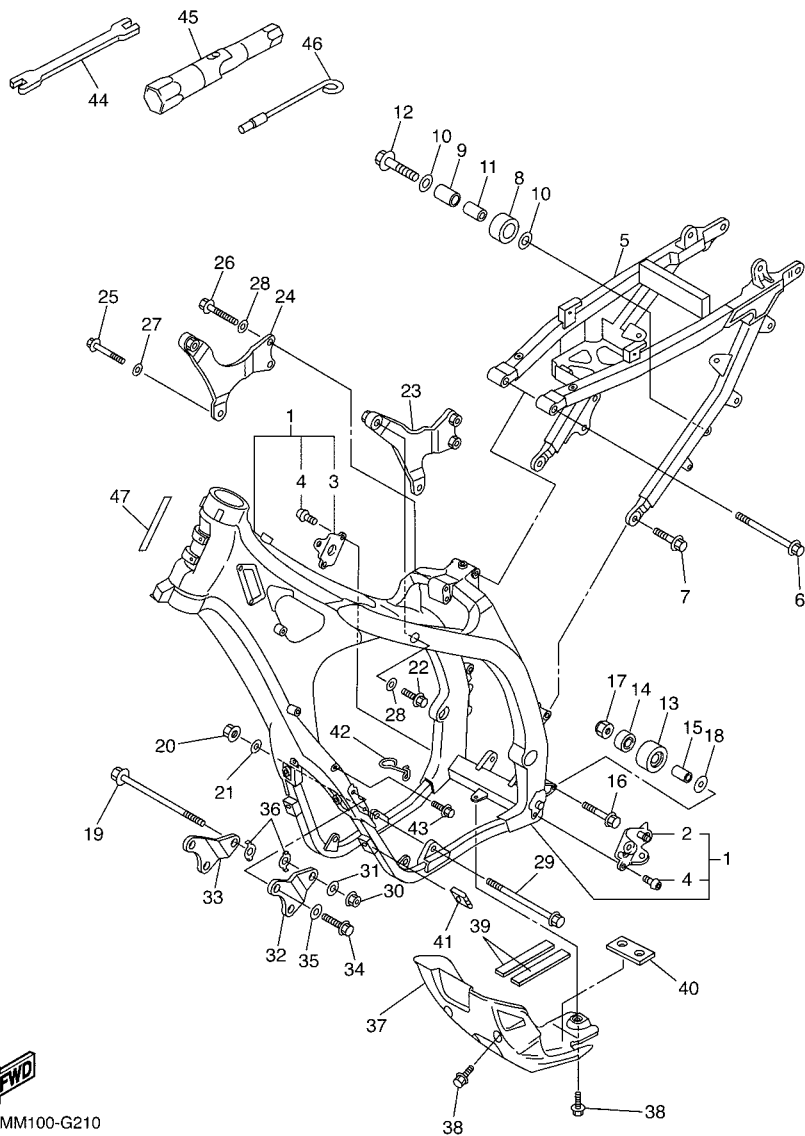
  
5UMB100-E190

**FIG. 20 SHIFT SHAFT**



5UME100-F200

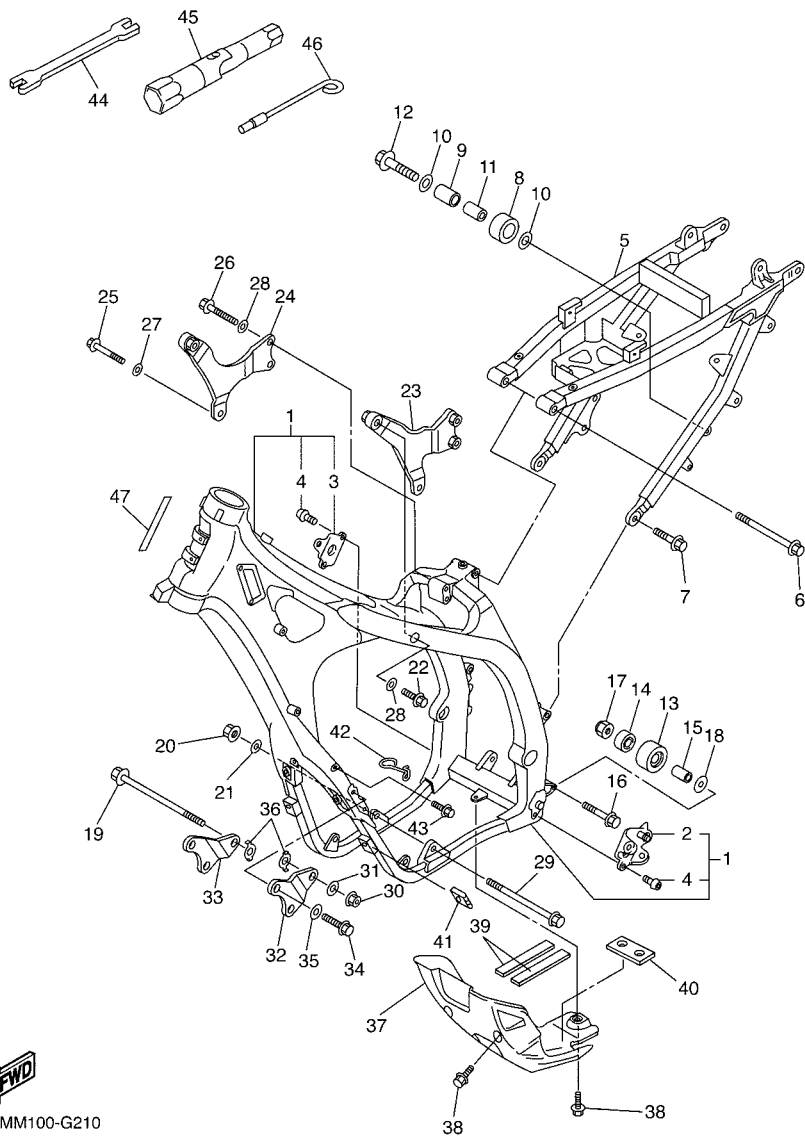
REF. NO.	PART NO.	DESCRIPTION	SUMM				REMARKS
1	2S2-18185-00	SEGMENT	1				
2	3XJ-18173-10	PIN, SHIFT	1				
3	5BE-18172-00	GUIDE, SHIFT	1				
4	90101-06041	BOLT	2				
5	5LP-18122-01	LEVER, SHIFT 2	1				
6	90501-052G5	SPRING, COMPRESSION	2				
7	3XJ-18184-00	PIN, PAWL	2				
8	3XJ-18182-00	PAWL, SHIFTER	2				
9	3XJ-18178-00	ROLLER, SHIFT LEVER	1				
10	5UL-18101-10	SHIFT SHAFT ASSY	1				
11	90387-124F4	COLLAR	1				
12	90508-291A8	SPRING, TORSION	1				
13	93608-33002	PIN, DOWEL	1				
14	93102-12224	OIL SEAL	1				
15	5XC-18110-00	SHIFT PEDAL ASSY	1				
16	95022-06020	BOLT, FLANGE	1				



5UMM100-G210

FIG. 21 FRAME

REF. NO.	PART NO.	DESCRIPTION	SUMM				REMARKS
1	5UM-21101-E0	FRONT FRAME COMP.	1				
2	5UM-21447-E0	.BRACKET, FOOTREST	1				
3	1C3-21448-10	.BRACKET, FOOTREST	1				
4	90149-10031	.SCREW	4				
5	5UM-21190-E0	REAR FRAME COMP.	1				
6	90105-08156	BOLT, FLANGE	1				
7	90105-08307	BOLT, FLANGE	2				
8	30X-22178-00	TENSIONER	1				
9	4V4-22184-00	BUSH	1				
10	90201-08045	WASHER, PLATE	2				
11	90387-08041	COLLAR	1				
12	95022-08040	BOLT, FLANGE	1				
13	3JD-22178-20	TENSIONER	1				
14	93300-60839	BEARING	1				
15	90387-086N4	COLLAR	1				
16	90105-08133	BOLT, FLANGE	1				
17	90185-08009	NUT, SELF-LOCKING	1				
18	90201-08043	WASHER, PLATE	1				
19	90105-10174	BOLT, FLANGE	1				
20	90179-10658	NUT	1				
21	90201-10045	WASHER, PLATE	1				
22	90105-08150	BOLT, FLANGE	2				
23	5UM-21425-E0	BRACKET, REAR UPPER 1	1				
24	5UM-21426-E0	BRACKET, REAR UPPER 2	1				
25	90105-10191	BOLT, FLANGE	1				
26	90105-08147	BOLT, FLANGE	2				
27	90201-10045	WASHER, PLATE	1				

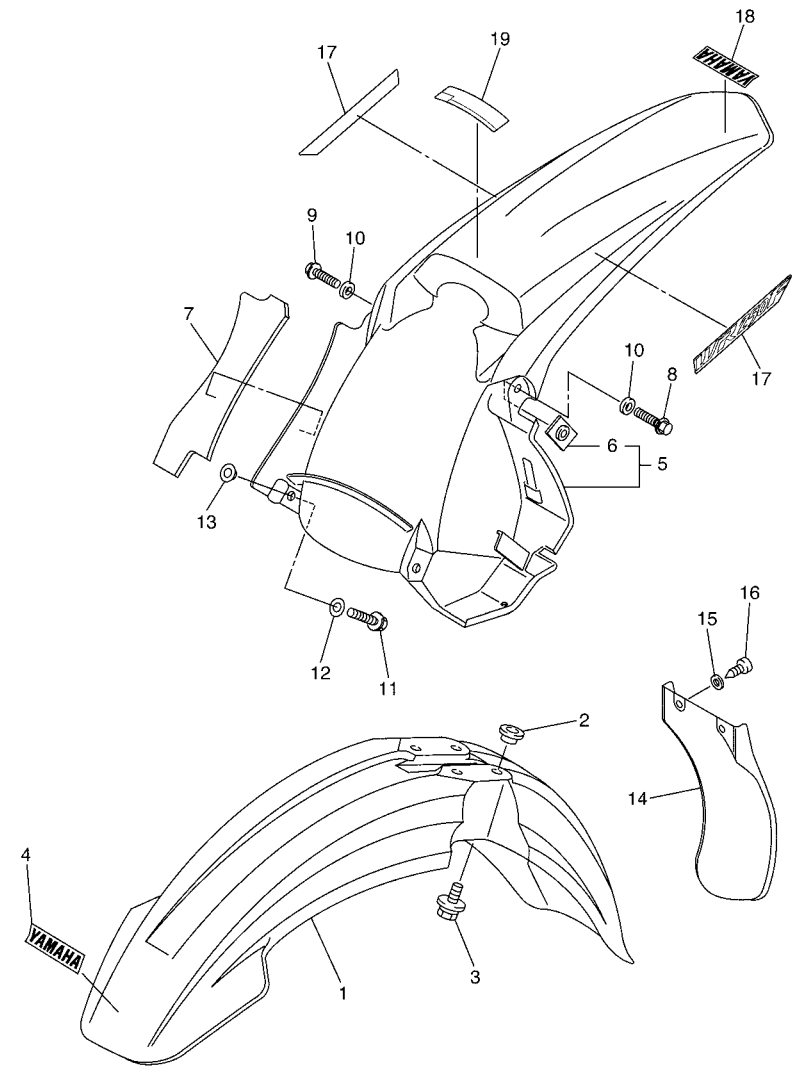


5UMM100-G210

FIG. 21 FRAME

REF. NO.	PART NO.	DESCRIPTION	SUMM				REMARKS
28	92902-08200	WASHER	4				
29	90105-10176	BOLT, FLANGE	1				
30	90179-10658	NUT	1				
31	90201-10045	WASHER, PLATE	1				
32	5UM-21417-E0	BRACKET, FRONT LOWER 1	1				
33	5UM-21418-E0	BRACKET, FRONT LOWER 2	1				
34	90105-08143	BOLT, FLANGE	4				
35	92902-08200	WASHER	4				
36	5XC-21456-90	PLATE, PATCH	2				
37	5UM-2147A-E0	GUARD, ENGINE 1	1				
38	90119-06166	BOLT, WITH WASHER	3				
39	5UM-21486-E0	DAMPER 2	2				
40	5UM-21485-E0	DAMPER, RUBBER 1	1				
41	5UM-21455-E0	PLATE, PATCH	2				
42	5XC-21288-90	GUIDE, CABLE	1				
43	90105-05014	BOLT, FLANGE	1				
44	5ET-28166-10	WRENCH, HEXAGON	1				
45	5TA-2814F-00	BOX, SPARK PLUG	1				
46	5XC-28116-00	TOOL, SPECIAL	1				
47	5UM-21268-E0	SEAL	1				

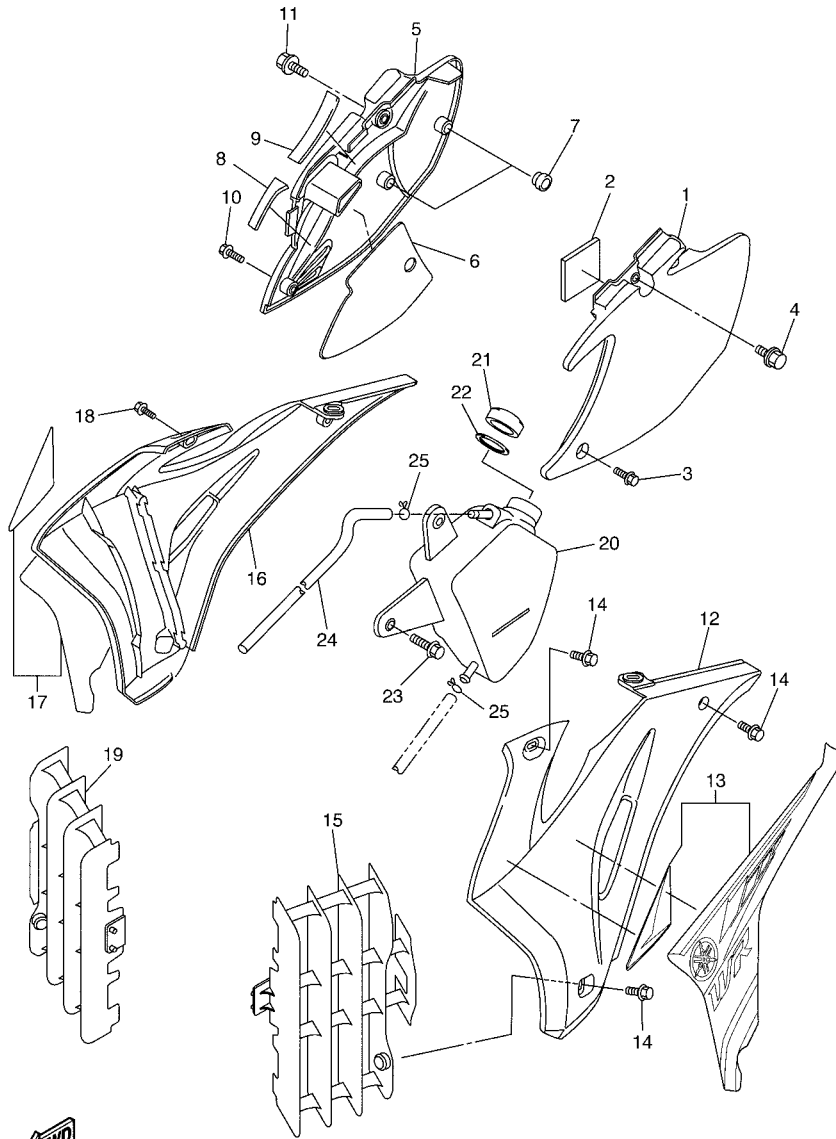
FIG. 22 FENDER



  
5UMM100-G220

REF. NO.	PART NO.	DESCRIPTION	SUMM				REMARKS
1	1C3-21511-51	FENDER, FRONT	1				
2	90387-06090	COLLAR	4				
3	90119-06147	BOLT, WITH WASHER	4				
4	4ES-2153E-01	EMBLEM, YAMAHA	1				
5	5UM-21610-E0	REAR FENDER COMP.	1				
6	5XE-21635-10	.NUT, REAR FENDER	2				
7	5UM-2174T-E0	INSULATOR, SIDE COVER 2	1				
8	90105-06127	BOLT, FLANGE	1				
9	90105-06100	BOLT, FLANGE	1				
10	90201-06032	WASHER, PLATE	2				
11	90105-06106	BOLT, FLANGE	2				
12	90201-06571	WASHER, PLATE	2				
13	90387-06009	COLLAR	2				
14	5TA-21642-00	GUARD, FLAP	1				
15	90201-06084	WASHER, PLATE	2				
16	97702-60016	SCREW, TAPPING	2				
17	5UM-2163G-20	EMBLEM 1	2				
18	5UM-2153E-00	EMBLEM, YAMAHA	1				
19	5PA-21568-00	LABEL, WARNING	1				

**FIG. 23 SIDE COVER**



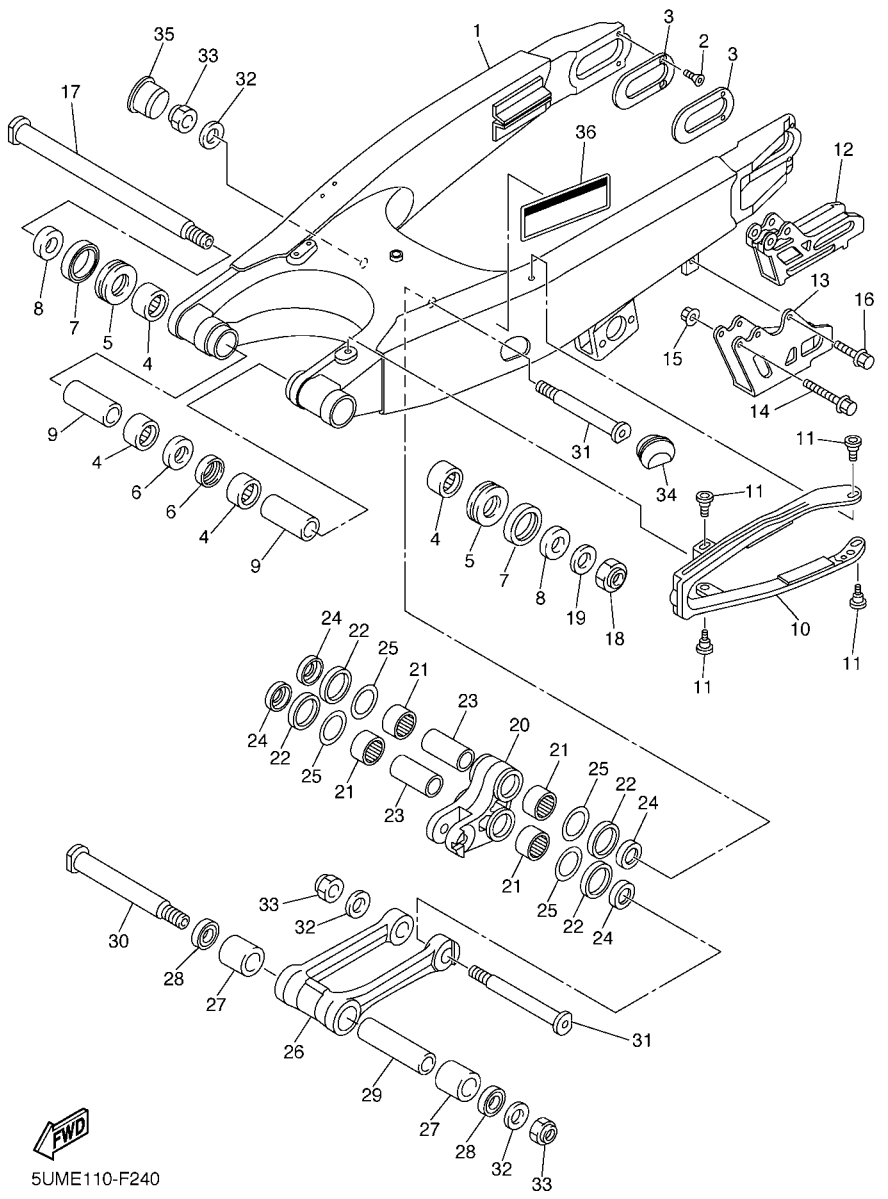
**FWD**  
5TJJ100-G230

REF. NO.	PART NO.	DESCRIPTION	SUMM				REMARKS
1	5UM-21711-E0	COVER, SIDE 1	1				
2	5UM-21717-E0	DAMPER	1				
3	90105-06103	BOLT, FLANGE	1				
4	90119-08095	BOLT, WITH WASHER	1				
5	5UM-21721-E0	COVER, SIDE 2	1				
6	5UM-2174A-E0	INSULATOR, SIDE COVER	1				
7	5XC-21719-90	GROMMET	2				
8	5UM-2172S-E0	INSULATOR 3	1				
9	5UM-2173S-E0	INSULATOR 4	1				
10	90105-06103	BOLT, FLANGE	1				
11	90119-08095	BOLT, WITH WASHER	1				
12	5UM-21730-E0	SIDE COVER ASSY 3	1				
13	5TJ-2173L-00	GRAPHIC SET 1	1				
14	90105-06064	BOLT, FLANGE	4				
15	2S2-2172A-70	PANEL 1	1				
16	5UM-21740-E0	SIDE COVER ASSY 4	1				
17	5TJ-2174L-00	GRAPHIC SET 2	1				
18	90105-06064	BOLT, FLANGE	4				
19	2S2-2172A-80	PANEL 1	1				
20	5UM-21860-E0	TANK ASSY	1				
21	26H-21875-00	CAP	1				
22	26H-21874-00	GASKET	1				
23	90119-06146	BOLT, WITH WASHER	1				
24	5UM-1244J-E0	HOSE 6	1				
25	90467-090A2	CLIP	2				



FIG. 24 REAR ARM

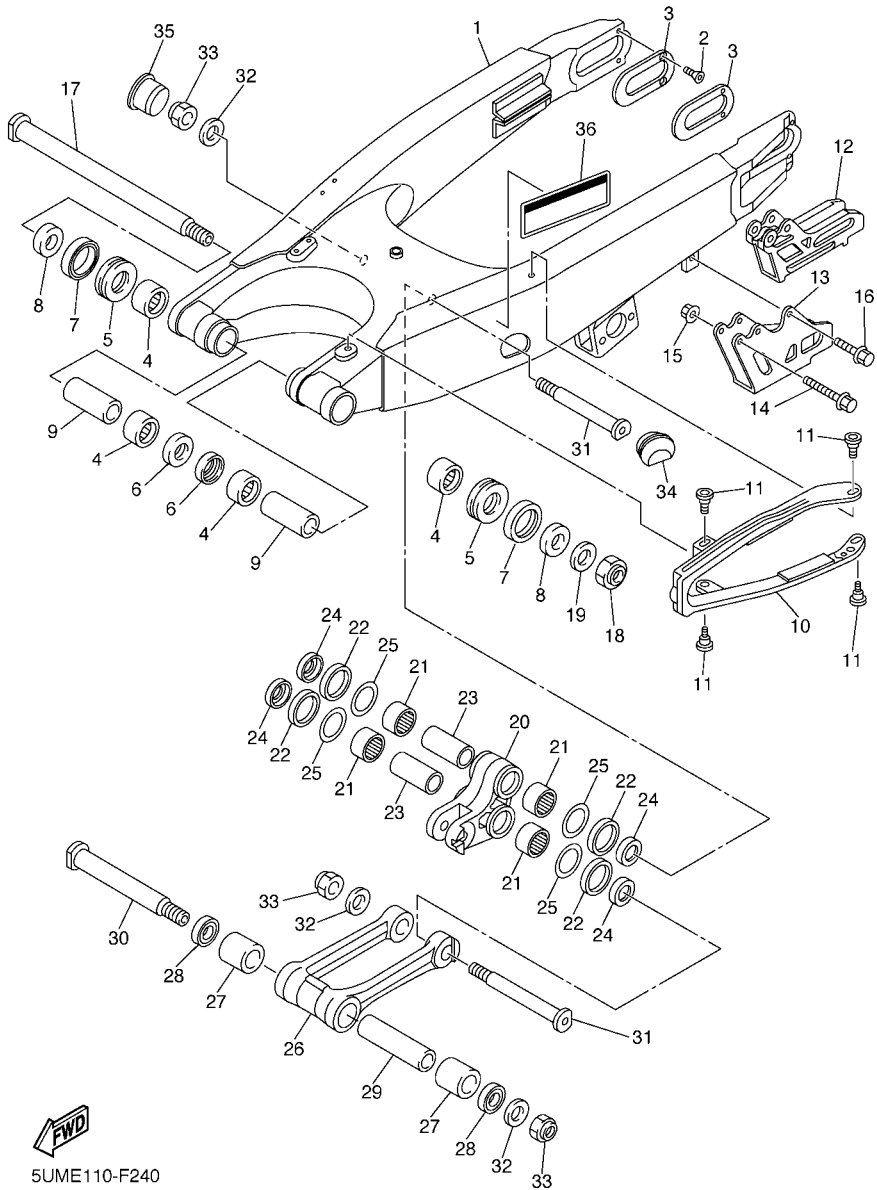
REF. NO.	PART NO.	DESCRIPTION	SUMM				REMARKS
1	2S2-22110-70	REAR ARM COMP.	1				
2	90151-04003	SCREW, COUNTERSUNK	4				
3	1P8-22355-00	PATCH	2				
4	93317-22262	BEARING	4				
5	93342-22217	BEARING	2				
6	93106-22002	OIL SEAL	2				
7	93109-28043	OIL SEAL	2				
8	90387-18012	COLLAR	2				
9	90387-18004	COLLAR	2				
10	2S2-22151-70	SEAL, GUARD	1				
11	1C3-22969-90	SCREW, 1	4				
12	5UM-22199-E0	SUPPORT, CHAIN	1				
13	2S2-22128-70	COVER, THRUST 1	1				
14	90105-06104	BOLT, FLANGE	2				
15	90179-06028	NUT	2				
16	90105-06105	BOLT, FLANGE	1				
17	1C3-22141-10	SHAFT, PIVOT	1				
18	90185-16002	NUT, SELF-LOCKING	1				
19	90201-16018	WASHER, PLATE	1				
20	5XC-2217A-90	ARM, RELAY	1				
21	93315-32166	BEARING	4				
22	93109-25001	OIL SEAL	4				
23	90387-16010	COLLAR	2				
24	90209-16011	WASHER	4				
25	90201-21014	WASHER, PLATE	4				
26	5XC-2217F-90	ROD, CONNECTING 1	1				
27	93315-32269	BEARING	2				

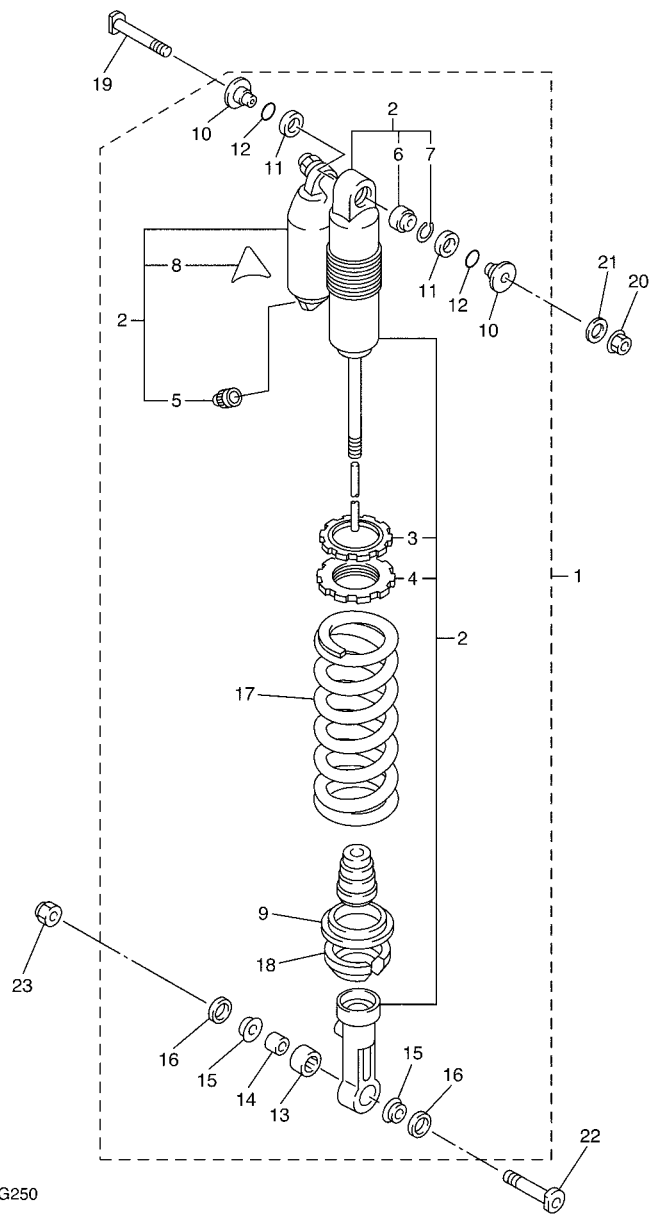


5UME110-F240

**FIG. 24 REAR ARM**

REF. NO.	PART NO.	DESCRIPTION	SUMM				REMARKS
28	93109-22019	OIL SEAL	2				
29	90387-14009	COLLAR	1				
30	5XC-22121-91	SHAFT 1	1				
31	1C3-22122-00	SHAFT 2	2				
32	90201-14020	WASHER, PLATE	3				
33	90185-14010	NUT, SELF-LOCKING	3				
34	1C3-2135F-00	COVER	1				
35	1C3-2139R-00	COVER 2	1				
36	3RV-21668-A0	LABEL, TIRE	1				
-----							
-----							
-----							
-----							
-----							

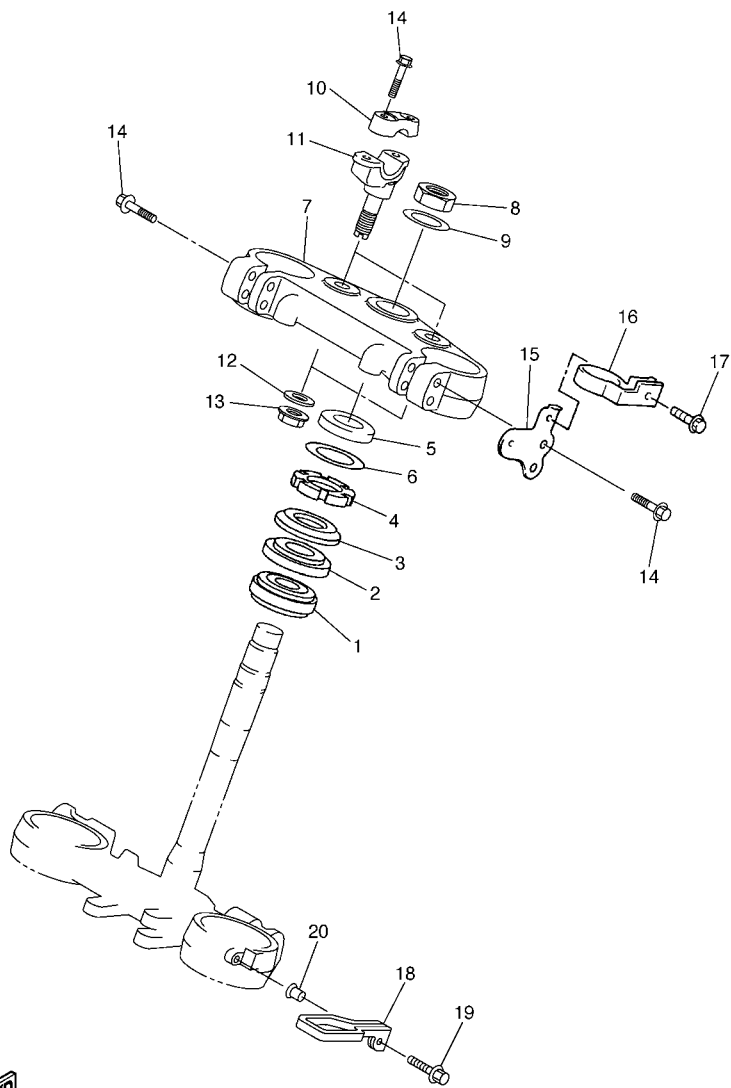




**FWD**  
5UMM100-G250

**FIG. 25 REAR SUSPENSION**

REF. NO.	PART NO.	DESCRIPTION	SUMM				REMARKS
1	5UM-22210-G0	SHOCK ABSORBER ASSY, REAR	1				
2	5UM-22201-G0	.DAMPER SUB ASSY	1				
3	3SP-22234-00	..GUIDE, SPRING 3	1				
4	3SP-22213-00	..SEAT, SPRING UPPER	1				
5	509-23184-L0	..CAP, AIR VALVE	1				
6	4JX-22226-00	..BUSH, SHOCK ABSORBER LOWER	1				
7	5DH-23183-00	..CIRCLIP	1				
8	4AA-22259-40	..LABEL, WARNING	1				
9	5MV-22224-00	.GUIDE, SPRING 2	1				
10	1C3-22253-50	.COLLAR, DISTANCE	2				
11	3JE-22475-00	.SEAL, DUST	2				
12	4EW-22474-00	.SEAL, RING	2				
13	5UN-22176-00	.BEARING	1				
14	5MV-22184-00	.BUSH	1				
15	5MV-22253-00	.COLLAR, DISTANCE	2				
16	5NY-22475-00	.SEAL, DUST	2				
17	5UN-22212-50	.SPRING (K=52N/MM)	1				
18	5XE-22214-00	.GUIDE, SPRING 1	1				
19	5XE-22242-00	BOLT 2	1				
20	95602-10200	NUT, U FLANGE	1				
21	92902-10200	WASHER	1				
22	5NY-22241-00	BOLT 1	1				
23	90185-10012	NUT, SELF-LOCKING	1				

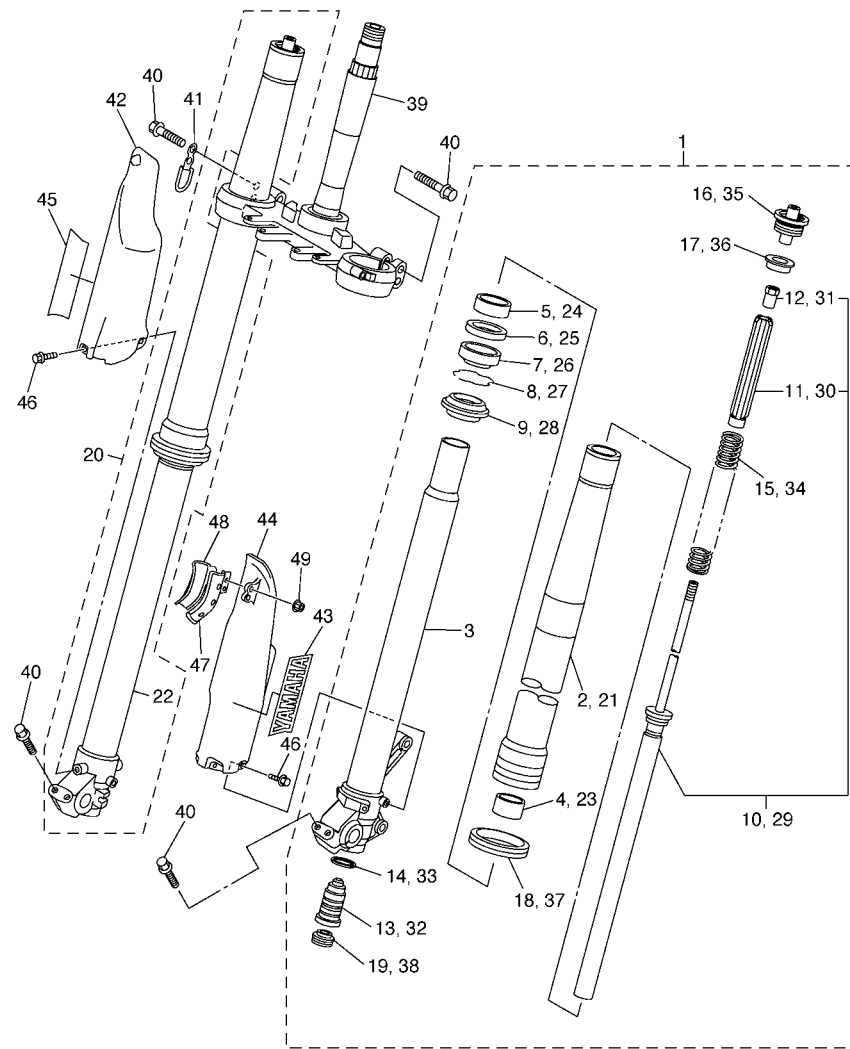


**FWD**  
5UME100-F260

**FIG. 26 STEERING**

REF. NO.	PART NO.	DESCRIPTION	SUMM				REMARKS
1	93332-00081	BEARING	1				
2	93332-00068	BEARING	1				
3	4EW-23416-00	COVER, BALL RACE 2	1				
4	90179-28003	NUT	1				
5	5UM-23113-E0	COLLAR	1				
6	90201-286K9	WASHER, PLATE (T1.0)	1				
7	5UM-23435-E1	CROWN, HANDLE	1				
8	90170-24003	NUT	1				
9	90201-24016	WASHER, PLATE	1				
10	5XC-23441-90	HOLDER, HANDLE UPPER	2				
11	5UM-23442-E0	HOLDER, HANDLE LOWER	2				
12	92902-10200	WASHER	2				
13	95602-10200	NUT, U FLANGE	2				
14	90105-08154	BOLT, FLANGE	8				
15	5UM-2831V-E0	STAY, HEAD LIGHT 1	1				
16	5TJ-2331E-80	GUIDE, CABLE	1				
17	90105-05016	BOLT, FLANGE	1				
18	5TJ-23389-80	GUIDE, CABLE	1				
19	90105-06107	BOLT, FLANGE	1				
20	90387-06104	COLLAR	1				

**D11**



5TJB100-E270

FIG. 27 FRONT FORK

REF. NO.	PART NO.	DESCRIPTION	SUMM				REMARKS
1	5UM-23102-F0	FRONT FORK ASSY (L.H)	1				
2	5TJ-23136-C0	.TUBE, OUTER (RIGHT)	1				
3	5TJ-23120-C0	.INNER TUBE COMP.2	1				
4	5XE-23171-L0	.PISTON, FRONT FORK	1				
5	5XE-23125-L0	.METAL, SLIDE 1	1				
6	5XE-23146-L0	.WASHER, OIL SEAL	1				
7	1C3-23145-L0	.OIL SEAL	1				
8	5XE-23153-L0	.RING, SNAP	1				
9	5XE-23144-L0	.SEAL, DUST	1				
10	5UM-23170-E0	.CYLINDER COMP., FRONT FORK	1				
11	5XE-23142-L0	..SEAT, SPRING UPPER	1				
12	5XE-23393-L0	..NUT, SPECIAL	1				
13	5UM-2316A-F0	.VALVE COMP.	1				
14	4SS-23158-L0	.GASKET	1				
15	5TJ-23141-A0	.SPRING,FRONT FORK(K=4.4N/MM)	1				
16	5XE-23111-L0	.BOLT, CAP	1				
17	5XE-23117-L0	.GUIDE, SPRING	1				
18	1C3-2314F-M0	.PROTECTOR GUIDE COMP, 1	1				
19	3JD-2312G-L0	.PLUG	1				
20	5UM-23103-F0	FRONT FORK ASSY (R.H)	1				
21	5TJ-23136-C0	.TUBE, OUTER (RIGHT)	1				
22	5TJ-23110-C0	.INNER TUBE COMP.1	1				
23	5XE-23171-L0	.PISTON, FRONT FORK	1				
24	5XE-23125-L0	.METAL, SLIDE 1	1				
25	5XE-23146-L0	.WASHER, OIL SEAL	1				
26	1C3-23145-L0	.OIL SEAL	1				
27	5XE-23153-L0	.RING, SNAP	1				

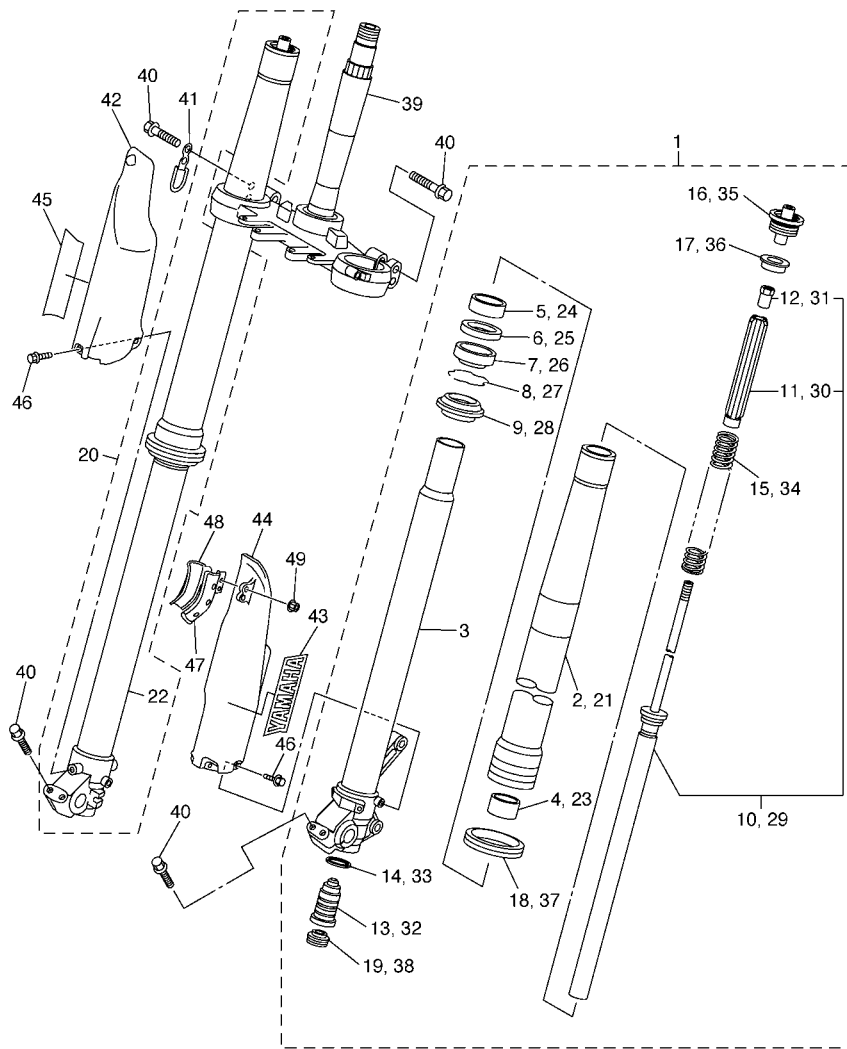


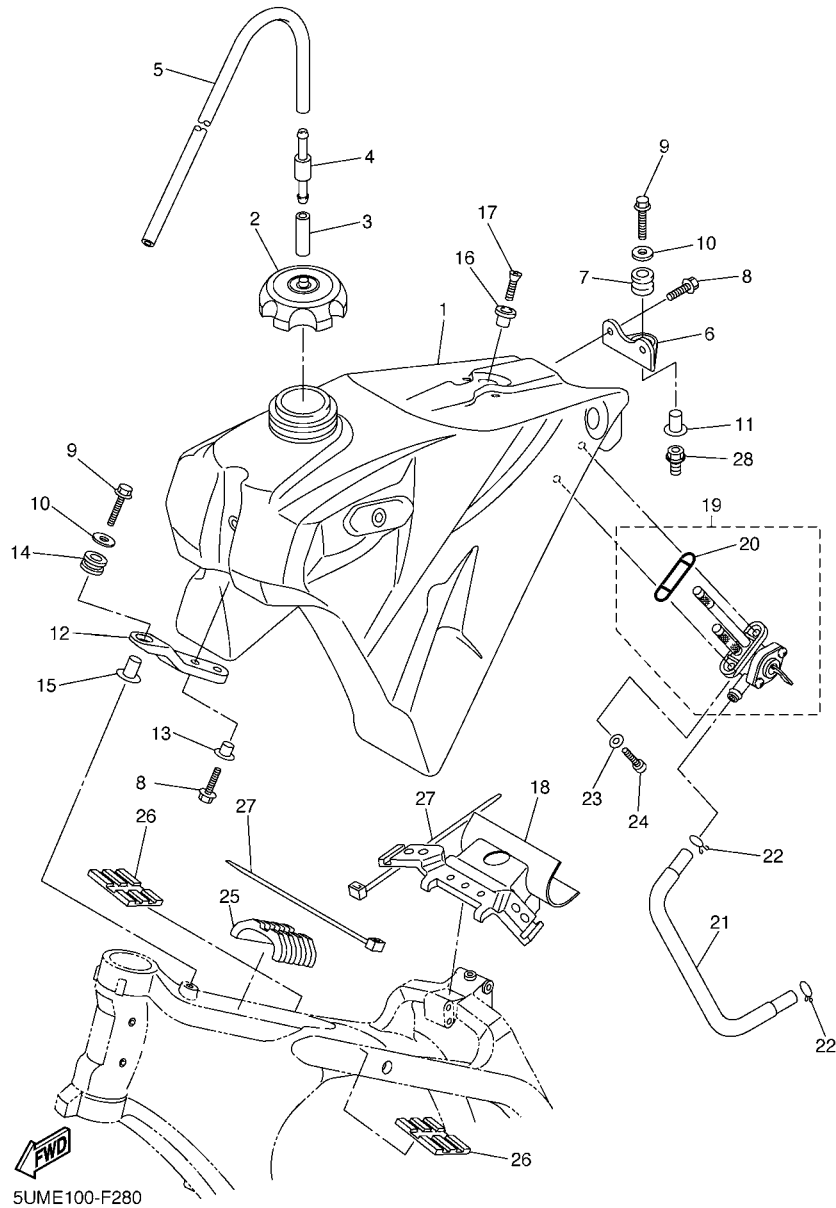
FIG. 27 FRONT FORK

REF. NO.	PART NO.	DESCRIPTION	SUMM				REMARKS
28	5XE-23144-L0	.SEAL, DUST	1				
29	5UM-23170-E0	.CYLINDER COMP., FRONT FORK	1				
30	5XE-23142-L0	..SEAT, SPRING UPPER	1				
31	5XE-23393-L0	..NUT, SPECIAL	1				
32	5UM-2316A-F0	.VALVE COMP.	1				
33	4SS-23158-L0	.GASKET	1				
34	5TJ-23141-A0	.SPRING,FRONT FORK(K=4.4N/MM)	1				
35	5XE-23111-L0	.BOLT, CAP	1				
36	5XE-23117-L0	.GUIDE, SPRING	1				
37	1C3-2314F-M0	.PROTECTOR GUIDE COMP., 1	1				
38	3JD-2312G-L0	.PLUG	1				
39	5UM-23340-L0	UNDER BRACKET COMP.	1				
40	90105-08134	BOLT, FLANGE	8				
41	5TJ-23525-C0	GUIDE	1				
42	5TJ-2315J-C0	PROTECTOR 2	1				
43	4XL-2153A-10	EMBLEM, YAMAHA	1				
44	1C3-2315H-10	PROTECTOR 1	1				
45	4XL-2153A-10	EMBLEM, YAMAHA	1				
46	3SP-23356-L0	BOLT 2	6				
47	5XC-23466-L0	CLAMP	1				
48	5XC-23467-L0	CLAMP	1				
49	95702-06500	NUT, WITH WASHER	2				



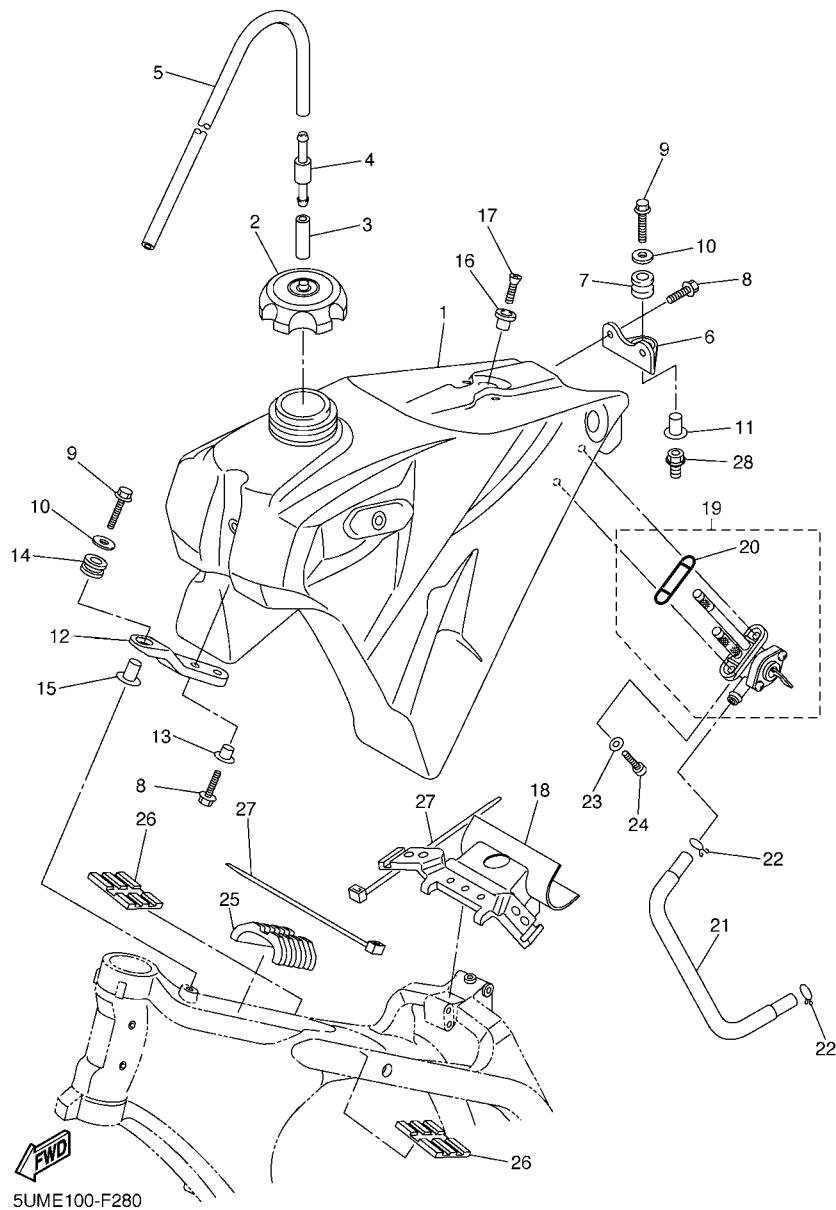
5TJB100-E270

**FIG. 28 FUEL TANK**



REF. NO.	PART NO.	DESCRIPTION	SUMM				REMARKS
1	5UM-24110-E1	FUEL TANK COMP.	1				
2	5NY-24610-00	CAP ASSY	1				
3	90445-09220	HOSE (L30)	1				
4	3XJ-24380-00	PIPE JOINT ASSY	1				
5	90445-09251	HOSE (L350)	1				
6	5XE-24144-00	HOLDER, DAMPER	1				
7	90480-18549	GROMMET	1				
8	90105-06107	BOLT, FLANGE	4				
9	90105-06111	BOLT, FLANGE	2				
10	90201-06570	WASHER, PLATE	2				
11	3JD-24186-00	WASHER, SPECIAL	1				
12	5UM-2419A-E0	HOLDER	1				
13	90387-06090	COLLAR	2				
14	5XC-24339-90	GROMMET	1				
15	90387-06065	COLLAR	1				
16	4EW-2412F-00	BRACKET, SEAT	1				
17	98702-06025	SCREW, FLAT HEAD	1				
18	5UM-24181-E0	DAMPER, LOCATING 1	1				
19	5UM-24500-E0	FUEL COCK ASSY 1	1				
20	1P6-24512-00	.GASKET	1				
21	5UM-24311-E0	PIPE, FUEL 1	1				
22	90467-100A1	CLIP	2				
23	90202-05193	WASHER, PLATE	2				
24	90149-06108	SCREW	2				
25	5XC-24182-90	DAMPER, LOCATING 2	1				
26	5XC-24183-90	DAMPER, LOCATING 3	2				
27	90465-13275	CLAMP	3				

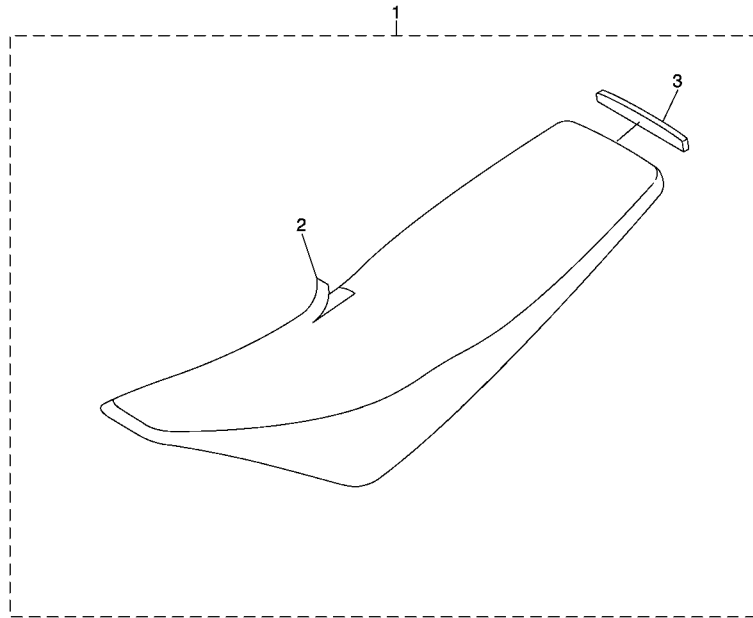
FIG. 28 FUEL TANK



REF. NO.	PART NO.	DESCRIPTION	SUMM				REMARKS
28	1C3-21244-10	NUT	1				

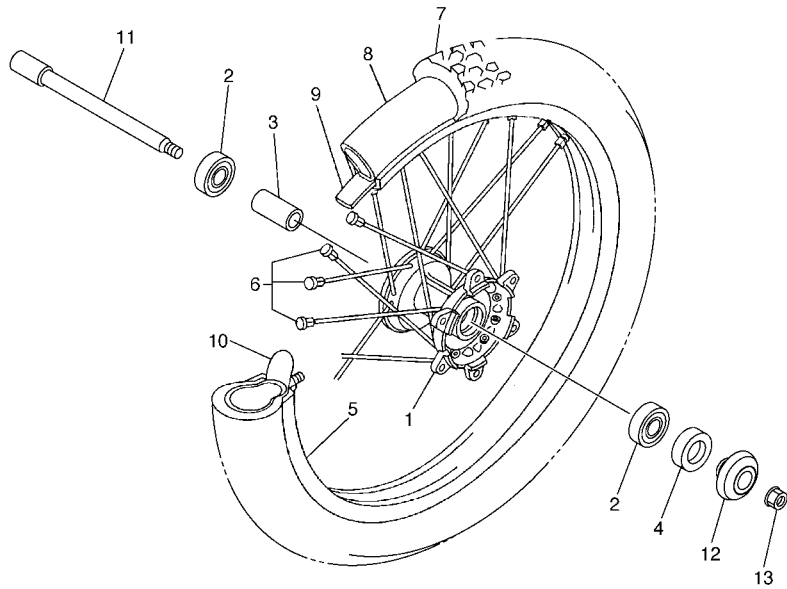


**FIG. 29 SEAT**



REF. NO.	PART NO.	DESCRIPTION	SUMM					REMARKS
1	5UM-24710-E0	SINGLE SEAT ASSY	1					
2	5UM-2470F-E0	.SEAT COVER COMP.	1					
3	5UM-24723-E0	.DAMPER, SEAT	1					

  
5TJE100-F290



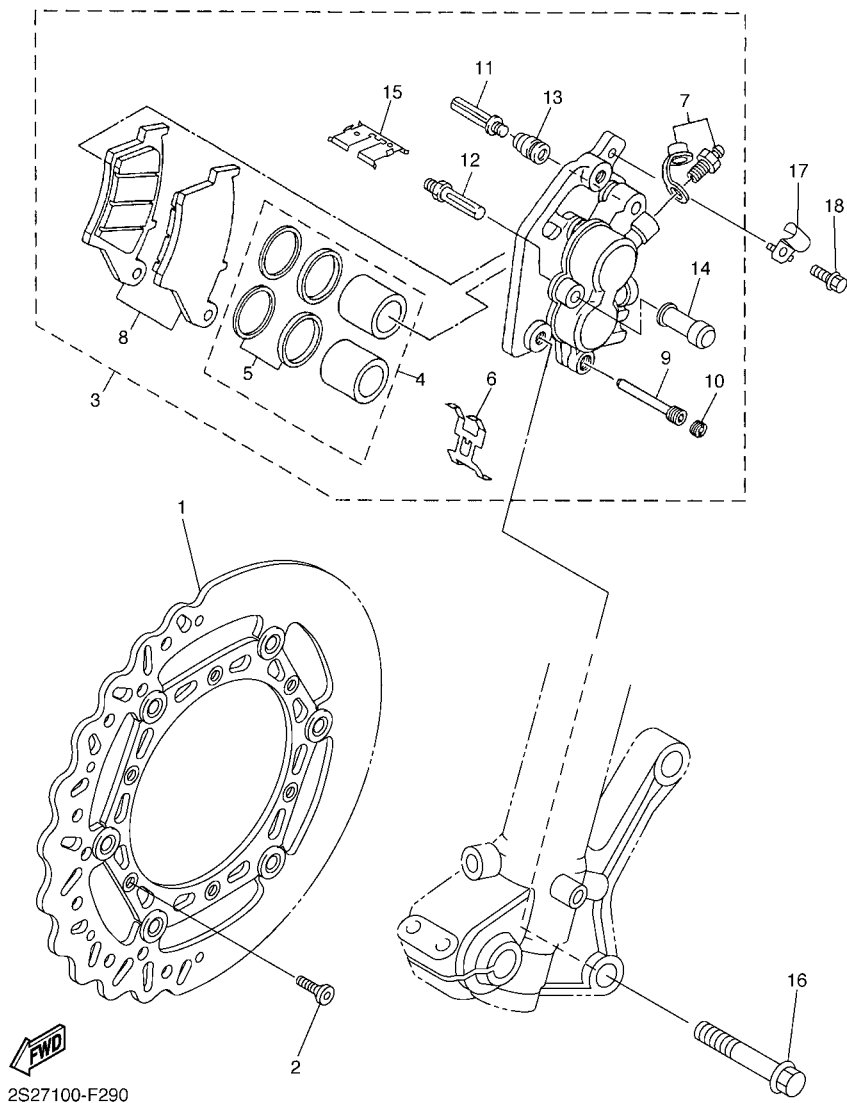
**FIG. 30 FRONT WHEEL**

REF. NO.	PART NO.	DESCRIPTION	SUMM				REMARKS
1	5NG-25111-50	HUB, FRONT	1				
2	93306-90409	BEARING	2				
3	5NY-25117-00	SPACER, BEARING	1				
4	93102-26468	OIL SEAL	1				
5	94416-21005	RIM (1.60-21)	1				
6	5NY-25104-00	SPOKE SET, FRONT	1				
7	94109-21009	TIRE (90/90-21 M/C 54R D908F)	1				UR DUNLOP(OCE)
	94108-21015	TIRE (80/100-21 51M D739FA)	1				UR DUNLOP(ZAF)
8	94227-21101	TUBE (80/100-21 M/C TR4)	1				DUNLOP
9	94309-21161	BAND, RIM (1.60-21)	1				DUNLOP
10	5SF-25394-00	SPACER, BEAD	1				
11	1C3-25181-10	AXLE, WHEEL	1				
12	5TJ-2510C-80	COLLAR ASSY.	1				
13	90179-16011	NUT	1				
-----							
-----							
-----							
-----							



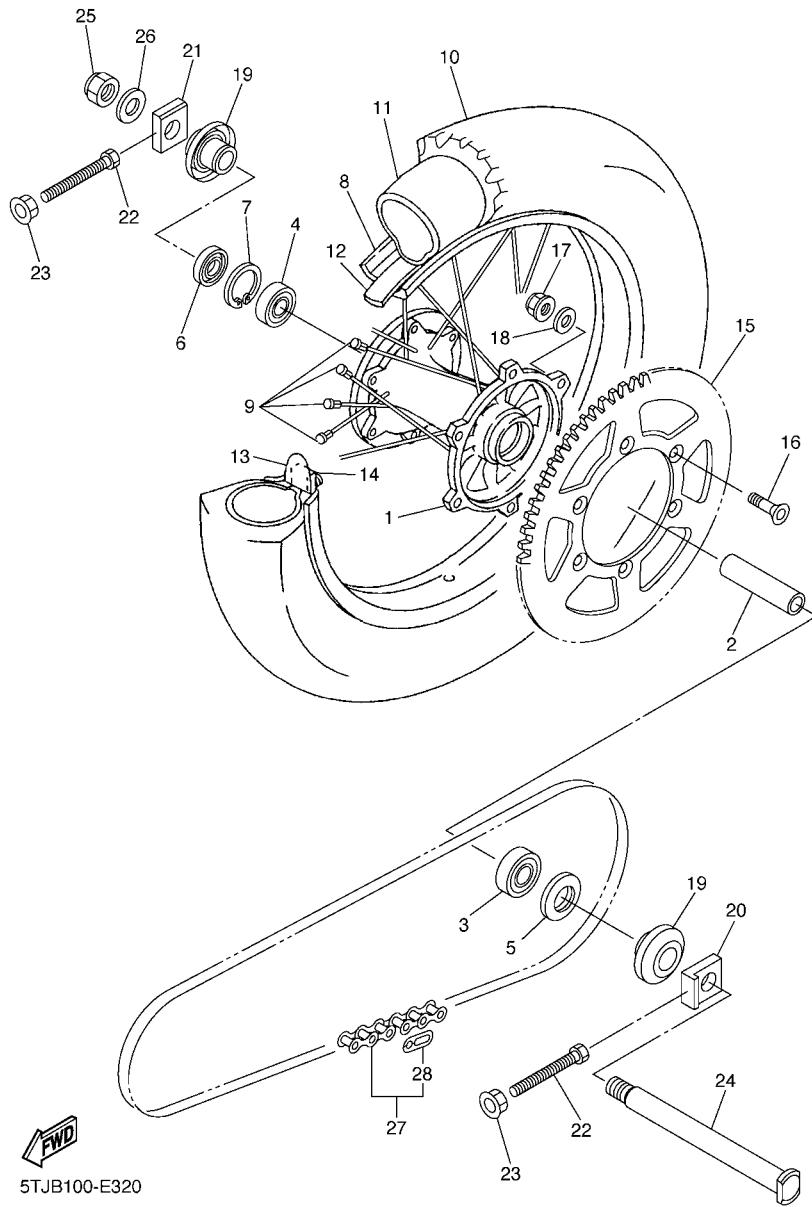
5TJB100-E300

**FIG. 31 FRONT BRAKE CALIPER**



2S27100-F290

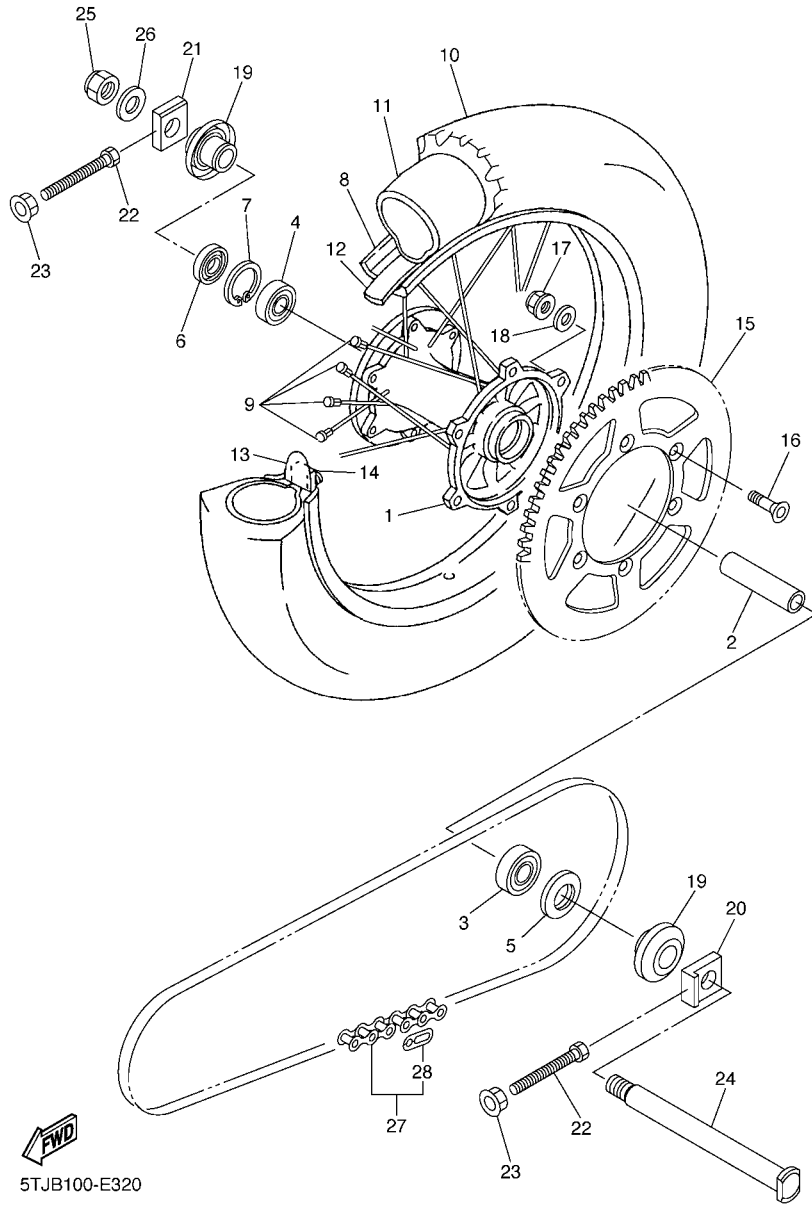
REF. NO.	PART NO.	DESCRIPTION	SUMM				REMARKS
1	2S2-2581T-70	DISK BRAKE ASSY	1				
2	90151-06051	SCREW, COUNTERSUNK	6				
3	1C3-2580T-00	CALIPER ASSY (LEFT)	1				
4	5UN-W0057-00	.PISTON ASSY, CALIPER	1				
5	3JD-W0047-00	..CALIPER SEAL KIT	1				
6	5DH-25919-00	.SUPPORT, PAD	1				
7	1UY-W0048-50	.BLEED SCREW KIT	1				
8	5MV-W0045-01	.BRAKE PAD KIT	1				
9	5DH-25933-00	.PIN, PAD	1				
10	5DH-25916-00	.PLUG	1				
11	3SP-25926-51	.BOLT	1				
12	3SP-25914-51	.PIN, SLIDE	1				
13	3JD-25917-00	.BOOT, CALIPER	1				
14	1UY-25937-51	.BOOT 2	1				
15	5DH-25849-00	.RETAINER, CALIPER	1				
16	90105-08137	BOLT, FLANGE	2				
17	1C3-25875-50	HOLDER, BRAKE HOSE 1	1				
18	90105-06105	BOLT, FLANGE	1				



5TJB100-E320

FIG. 32 REAR WHEEL

REF. NO.	PART NO.	DESCRIPTION	SUMM				REMARKS
1	5ET-25311-00	HUB, REAR	1				
2	5ET-25317-00	SPACER, BEARING	1				
3	93306-27212	BEARING	1				
4	93306-07202	BEARING	1				
5	93106-30001	OIL SEAL	1				
6	93106-30045	OIL SEAL	1				
7	99009-45500	CIRCLIP	1				
8	94421-18005	RIM (2.15-18)	1				UR FOR OCE
	94418-18006	RIM (1.85-18)	1				UR FOR ZAF
9	5GS-25304-00	SPOKE SET, REAR	1				
10	94113-18015	TIRE (130/90-18 M/C 69R D908)	1				UR DUNLOP(OCE)
	94110-18009	TIRE (100/100-18 59M D756)	1				UR DUNLOP(ZAF)
11	94213-18012	TUBE (4.50,5.10,130/90-18)	1				UR DUNLOP(OCE)
	94211-18176	TUBE (100/100-18 M/C TR4)	1				UR DUNLOP(ZAF)
12	94309-18146	BAND, RIM (2.15-18)	1				DUNLOP
13	3JE-25394-00	SPACER, BEAD	2				UR FOR OCE
	4XM-25394-00	SPACER, BEAD	2				UR FOR ZAF
14	4XM-25364-00	DAMPER	2				
15	1C3-25450-00	SPROCKET, DRIVEN (50T)	1				STD FOR OCE
	5TJ-25450-80	SPROCKET, DRIVEN (50T)	1				STD FOR ZAF
	1C3-25448-00	SPROCKET, DRIVEN (48T)	1				AP FOR OCE
	1C3-25449-00	SPROCKET, DRIVEN (49T)	1				AP FOR OCE
	1C3-25451-00	SPROCKET, DRIVEN (51T)	1				AP FOR OCE
	1C3-25452-00	SPROCKET, DRIVEN (52T)	1				AP FOR OCE
	5GS-25448-50	SPROCKET, DRIVEN (48T)	1				AP FOR ZAF
	5TJ-25452-80	SPROCKET, DRIVEN (52T)	1				AP FOR ZAF
16	90109-08078	BOLT	6				



**FIG. 32 REAR WHEEL**

REF. NO.	PART NO.	DESCRIPTION	SUMM				REMARKS
17	90185-08008	NUT, SELF-LOCKING	6				
18	90201-08048	WASHER, PLATE	6				
19	5TJ-2530S-80	COLLAR ASSY	2				
20	1C3-25388-50	PULLER, CHAIN 1	1				
21	1C3-25389-00	PULLER, CHAIN 2	1				
22	90101-08006	BOLT	2				
23	90179-08019	NUT	2				
24	1C3-25381-90	AXLE, WHEEL	1				
25	90185-20002	NUT, SELF-LOCKING	1				
26	90201-20020	WASHER, PLATE	1				
27	9Y58A-76113	CHAIN (DID 520VM-114LL)	1				
28	94681-76021	.JOINT, CHAIN (DID 520VM-ZJ)	1				
-----							
-----							
-----							
-----							
-----							

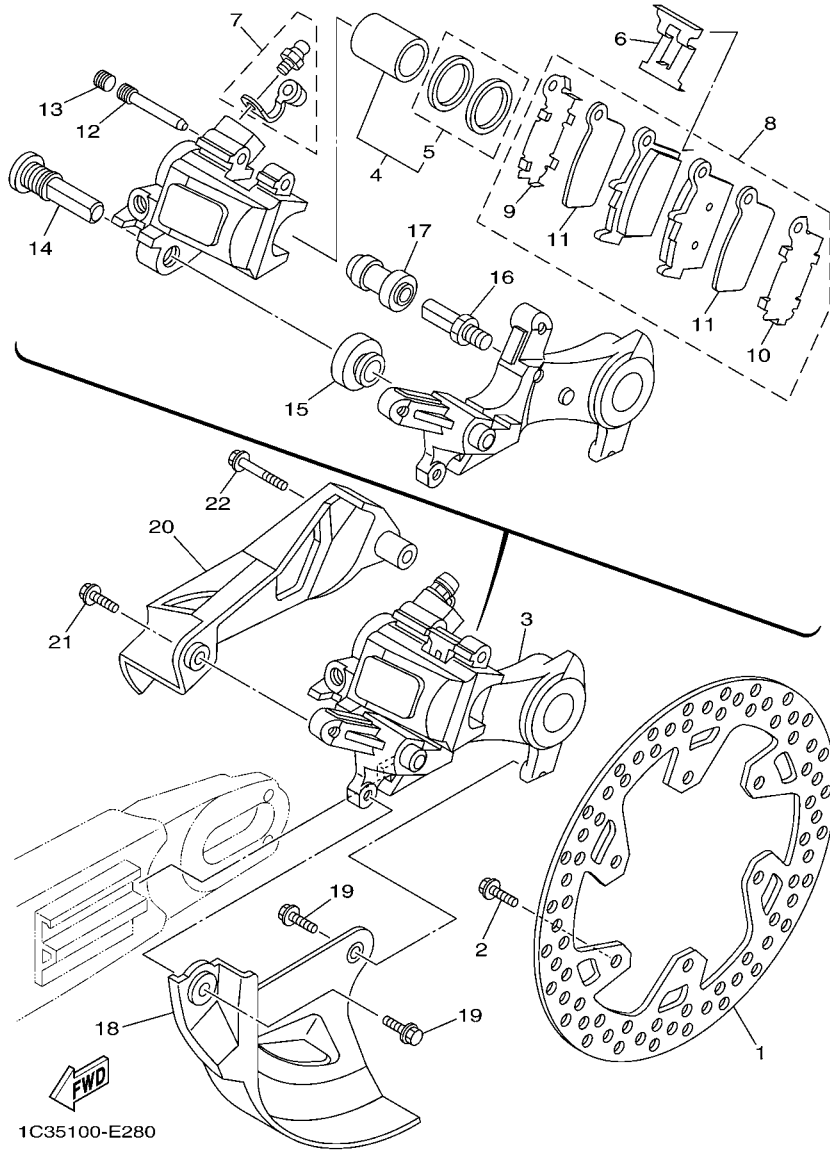
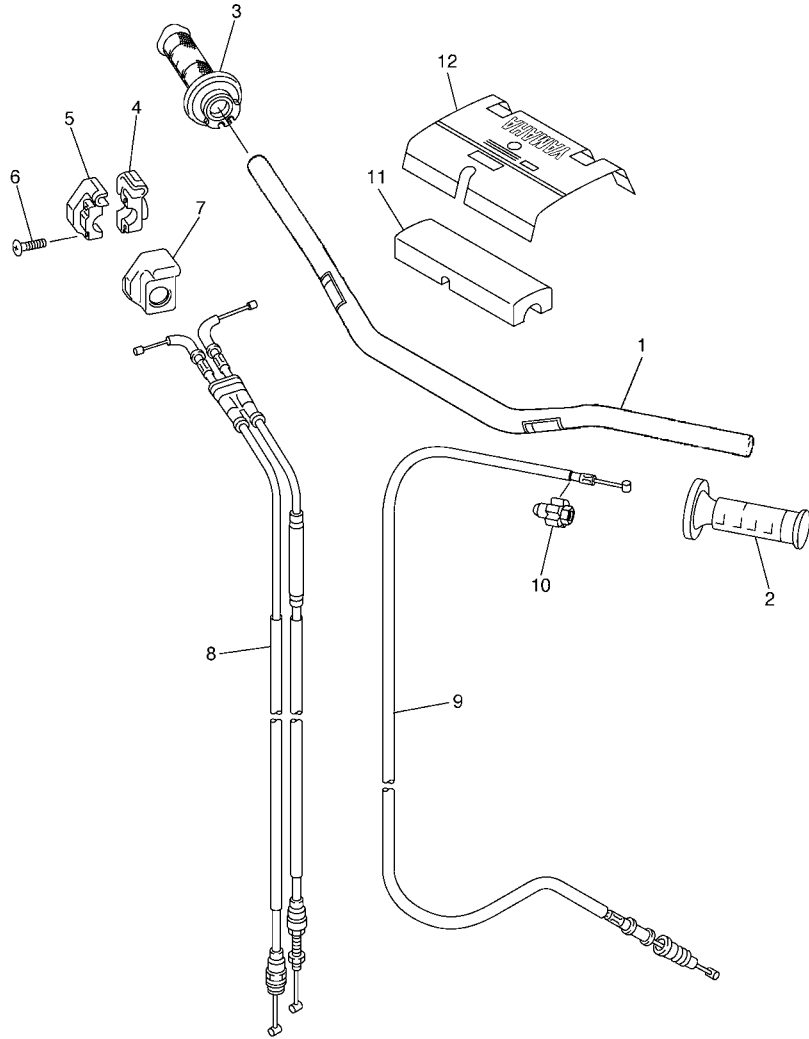


FIG. 33 REAR BRAKE CALIPER

REF. NO.	PART NO.	DESCRIPTION	SUMM				REMARKS
1	2S2-2582W-70	DISK, REAR BRAKE 2	1				
2	90105-06108	BOLT, FLANGE	6				
3	1C3-2580W-71	CALIPER ASSY, REAR 2	1				
4	5UN-W0057-50	.PISTON ASSY, CALIPER	1				
5	5UN-W0047-50	..CALIPER SEAL KIT	1				
6	5DH-25919-50	..SUPPORT, PAD	1				
7	1UY-W0048-50	.BLEED SCREW KIT	1				
8	1C3-W0046-B0	.BRAKE PAD KIT 2	1				
9	5UN-25828-60	..SHIM, CALIPER	1				
10	5UN-25827-60	..SHIM, CALIPER	1				
11	5UN-22898-60	..INSULATOR, HEAT	2				
12	8CR-25924-00	.PIN, PAD	1				
13	5DH-25916-00	.PLUG	1				
14	5DH-25914-50	.PIN, SLIDE	1				
15	3JD-25917-00	.BOOT, CALIPER	1				
16	5UN-25914-00	.PIN, SLIDE	1				
17	1UY-25937-51	.BOOT 2	1				
18	1C3-25718-50	PROTECTOR, DISK BRAKE	1				
19	90105-06110	BOLT, FLANGE	2				
20	1C3-27491-50	PROTECTOR	1				
21	90105-06107	BOLT, FLANGE	1				
22	90105-06111	BOLT, FLANGE	1				

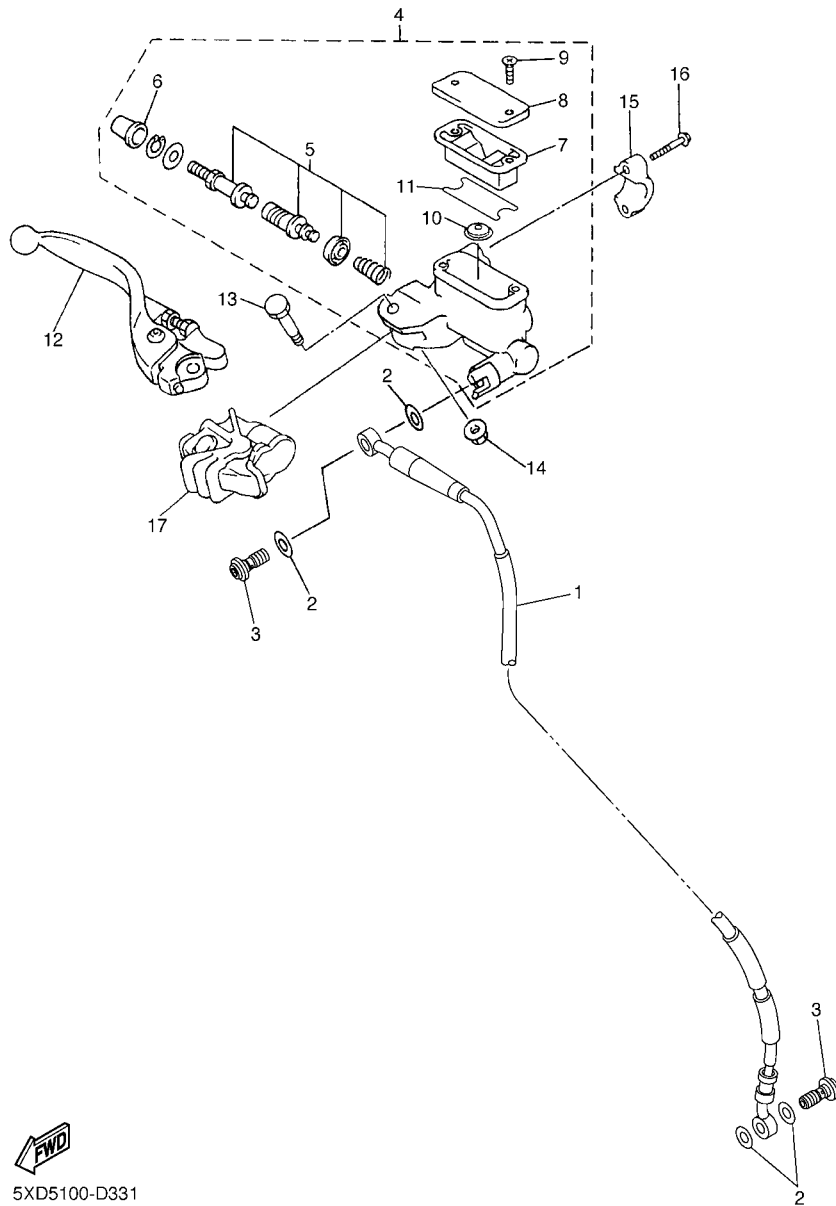


**FIG. 34 STEERING HANDLE & CABLE**

REF. NO.	PART NO.	DESCRIPTION	SUMM				REMARKS
1	5XC-26111-L0	HANDLEBAR	1				
2	4GY-26241-00	GRIP	1				
3	5TJ-26240-C0	GRIP ASSY	1				
4	5BE-26281-00	CAP, GRIP UPPER	1				
5	5BE-26282-00	CAP, GRIP LOWER	1				
6	98502-05020	SCREW, PAN HEAD	2				
7	5SF-26287-10	COVER, CAP GRIP	1				
8	5UM-26302-E0	THROTTLE CABLE ASSY	1				
9	5UM-26335-E0	CABLE, CLUTCH	1				
10	1C3-26342-50	BOOT, CABLE	1				
11	5XC-26124-90	PROTECTOR, HANDLEBAR	1				
12	5XC-26143-L0	COVER, HANDLEBAR UPPER 1	1				

  
5UME100-F340

**FIG. 35 FRONT MASTER CYLINDER**



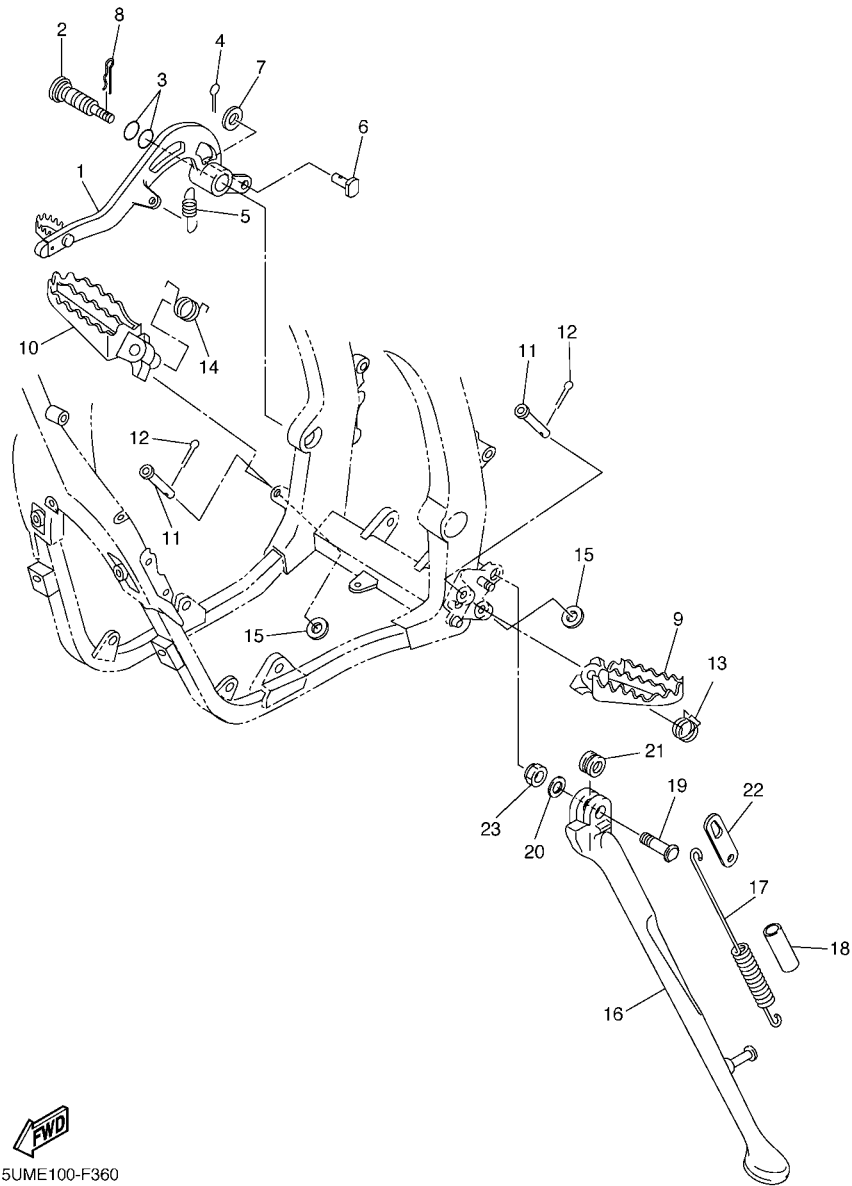
REF. NO.	PART NO.	DESCRIPTION	SUMM				REMARKS
1	5TJ-25872-80	HOSE, BRAKE 1	1				
2	90430-10005	GASKET	4				
3	90401-10172	BOLT, UNION	2				
4	5XE-W2587-10	MASTER CYLINDER SUB ASSY	1				
5	5NY-W0041-00	.CYLINDER KIT, MASTER	1				
6	5NY-25868-00	.BOOT, MASTER CYLINDER	1				
7	5XE-25854-00	.DIAPHRAGM, RESERVOIR	1				
8	5MV-25852-01	.CAP, RESERVOIR	1				
9	98706-04012	.SCREW, FLAT HEAD	2				
10	5CG-25715-00	.SEPARATOR ASSY	1				
11	5XE-25853-00	.FLOAT, RESERVOIR	1				
12	1C3-83922-50	LEVER 2	1				
13	5MV-2589F-00	BOLT, LEVER	1				
14	95701-06500	NUT, WITH WASHER	1				
15	5MV-25867-00	BRACKET, MASTER CYLINDER	1				
16	5MV-25833-00	BOLT, FITTING	2				
17	5NY-26372-00	COVER, HANDLE LEVER 1	1				



5XD5100-D331

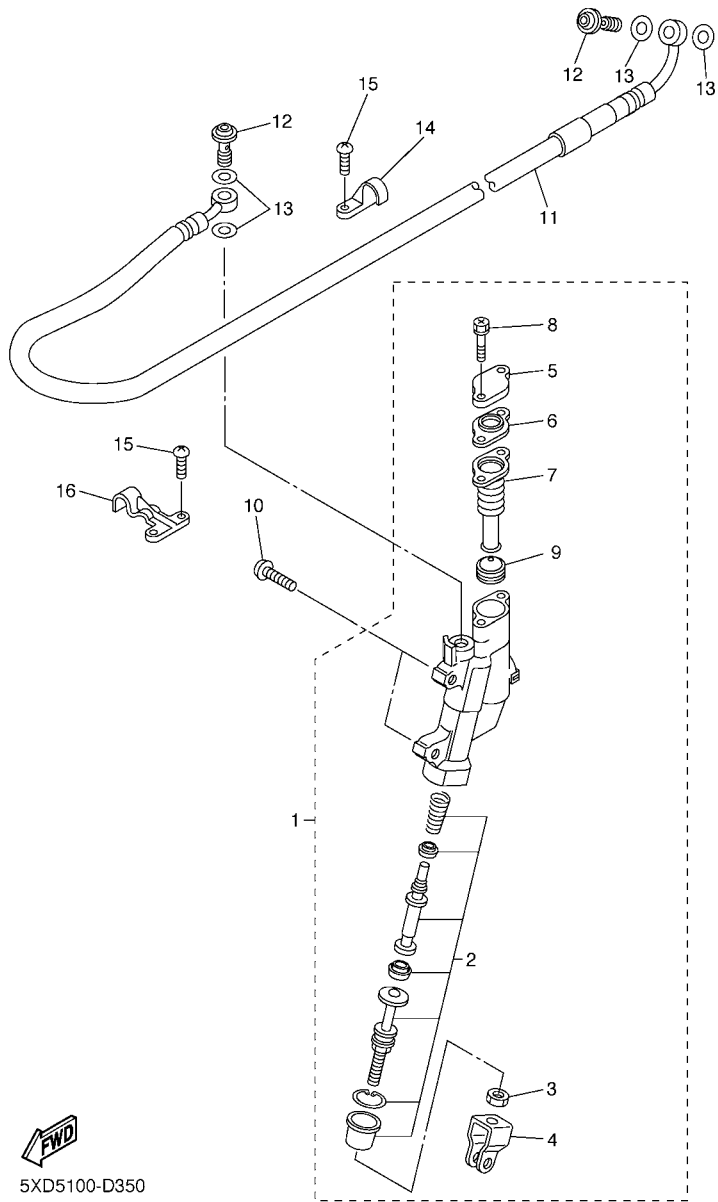


FIG. 36 STAND & FOOTREST



  
5UME100-F360

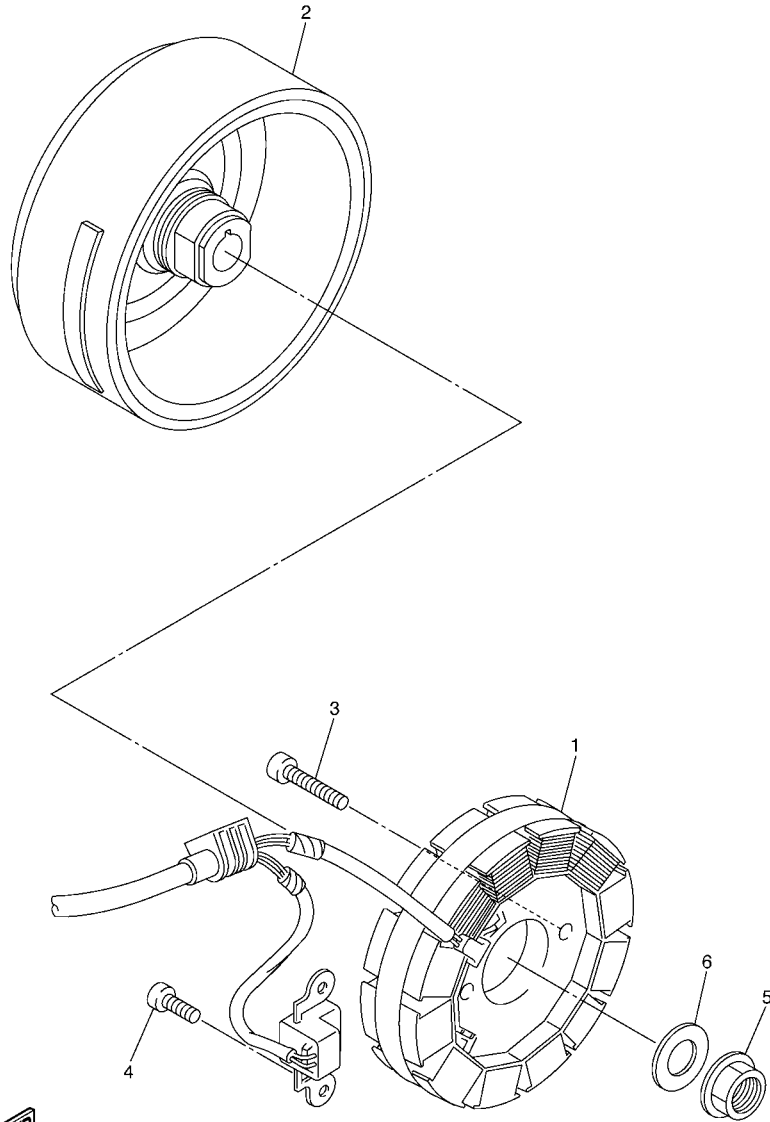
REF. NO.	PART NO.	DESCRIPTION	SUMM				REMARKS
1	5XC-27200-A0	PEDAL, BRAKE	1				
2	5XC-27217-90	BOLT	1				
3	93210-11073	O-RING	2				
4	91402-20012	PIN, COTTER	1				
5	90506-16007	SPRING, TENSION	1				
6	90240-08120	PIN, CLEVIS	1				
7	90201-08044	WASHER, PLATE	1				
8	90468-16001	CLIP	1				
9	5XC-27411-M0	FOOTREST 1	1				
10	5XC-27421-M0	FOOTREST 2	1				
11	90240-10004	PIN, CLEVIS	2				
12	91402-25015	PIN, COTTER	2				
13	90508-28015	SPRING, TORSION	1				
14	90508-28018	SPRING, TORSION	1				
15	90201-10032	WASHER, PLATE	2				
16	5UM-27311-E0	STAND, SIDE	1				
17	90506-30005	SPRING, TENSION	1				
18	90445-217G3	HOSE (L70)	1				
19	90109-10026	BOLT	1				
20	90201-10045	WASHER, PLATE	1				
21	90387-1003G	COLLAR	1				
22	5UM-27315-E0	LINK, SIDE STAND	1				
23	90185-10018	NUT, SELF-LOCKING	1				



5XD5100-D350

FIG. 37 REAR MASTER CYLINDER

REF. NO.	PART NO.	DESCRIPTION	SUMM				REMARKS
1	1C3-2583V-00	RR. MASTER CYLINDER ASSY.	1				
2	5UN-W0042-50	.CYLINDER KIT, MASTER	1				
3	5UN-27218-00	.NUT	1				
4	5UN-27222-00	.JOINT	1				
5	5UN-25852-50	.CAP, RESERVOIR	1				
6	5UN-2585B-00	.PLATE, DIAPHRAGM	1				
7	5UN-25854-00	.DIAPHRAGM, RESERVOIR	1				
8	5UN-27217-00	.BOLT	2				
9	5CG-25715-00	.SEPARATOR ASSY	1				
10	90111-06059	BOLT,HEX. SOCKET BUTTON	2				
11	5XC-25873-L0	HOSE, BRAKE 2	1				
12	90401-10172	BOLT, UNION	2				
13	90430-10005	GASKET	4				
14	1C3-25886-50	HOLDER, BRAKE HOSE	1				
15	98502-05010	SCREW, PAN HEAD	4				
16	1C3-25876-50	HOLDER, BRAKE HOSE 2	1				



5UM5100-C370

FIG. 38 GENERATOR

REF. NO.	PART NO.	DESCRIPTION	SUMM				REMARKS
1	5UM-81410-30	STATOR ASSY	1				
2	5UM-81450-00	ROTOR ASSY	1				
3	91312-05020	BOLT	2				
4	91312-06014	BOLT	2				
5	90179-12657	NUT	1				
6	90201-12020	WASHER, PLATE	1				
-----							
-----							
-----							
-----							
-----							
-----							
-----							

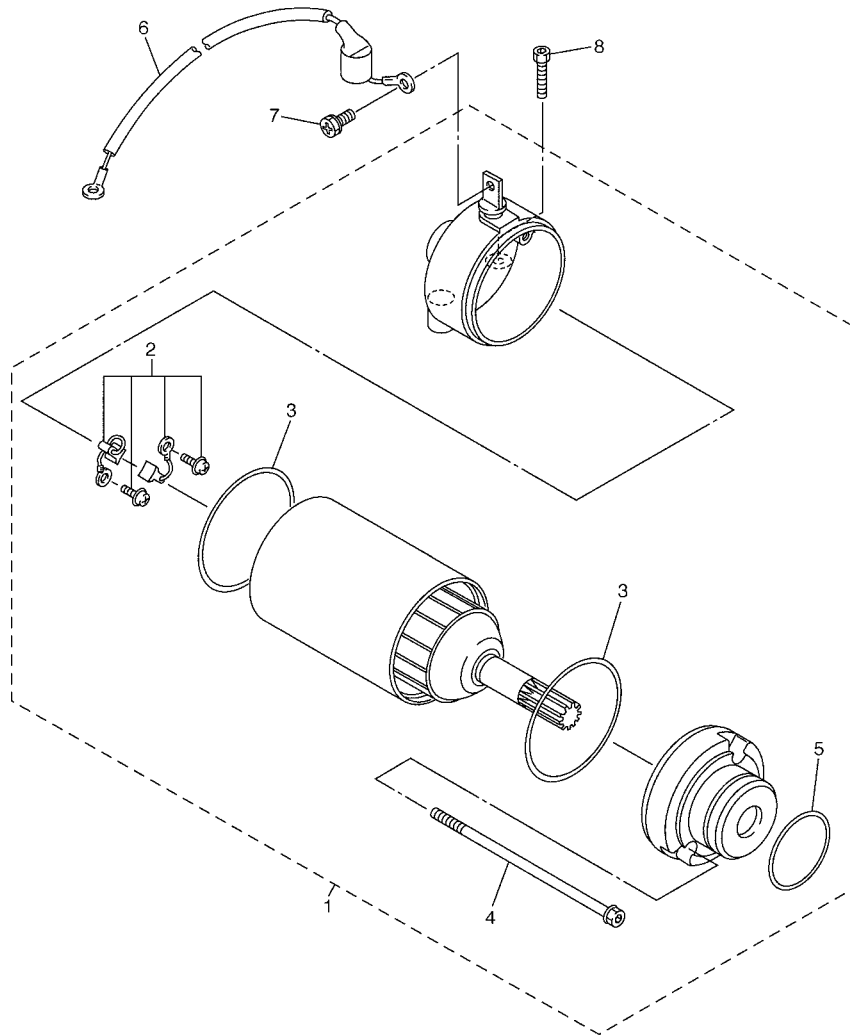


FIG. 39 STARTING MOTOR

REF. NO.	PART NO.	DESCRIPTION	SUMM				REMARKS
1	5UM-81890-10	MOTOR ASSY	1				
2	5UM-81801-10	.BRUSH SET	1				
3	5UM-81861-00	.GASKET	2				
4	5UM-81828-10	.BOLT 2	2				
5	93210-25711	.O-RING	1				
6	5UM-8183G-20	CORD COMP.	1				
7	5TJ-81828-01	BOLT 2	1				
8	91312-06025	BOLT	2				



5UM5100-C380

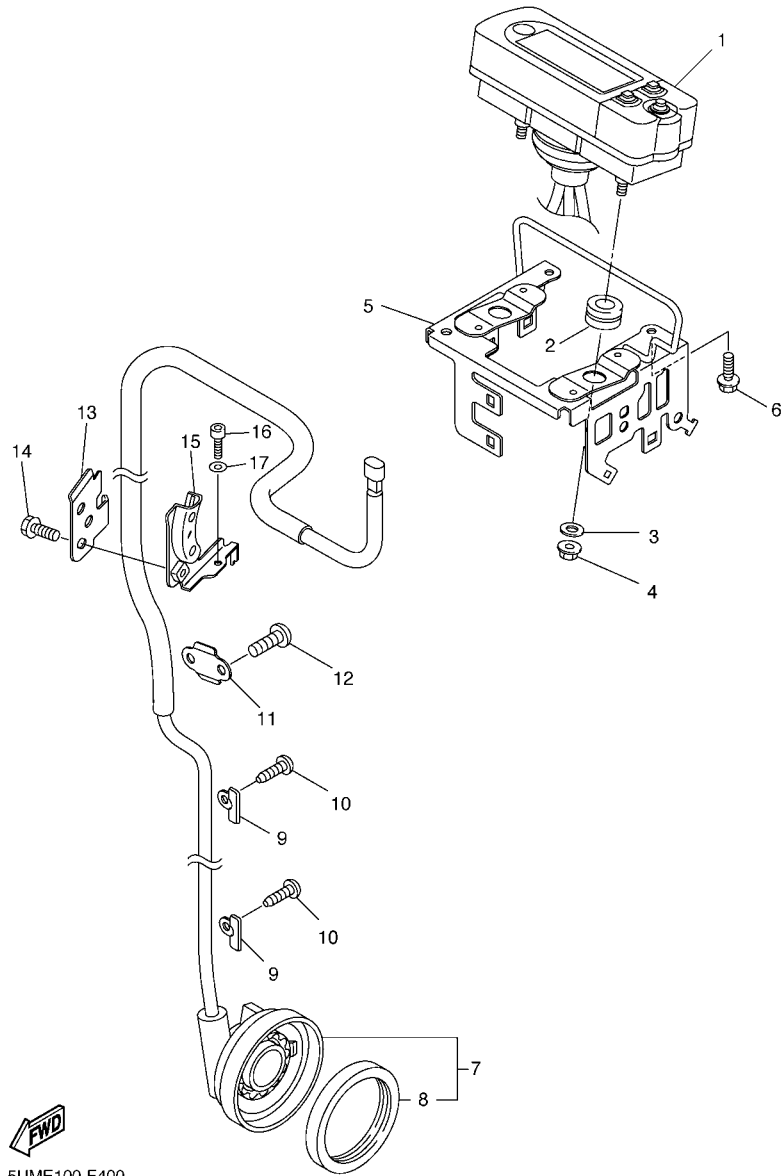


FIG. 40 METER

REF. NO.	PART NO.	DESCRIPTION	SUMM				REMARKS
1	5TJ-83500-F0	SPEEDOMETER ASSY (KM/H)	1				
2	90480-14012	GROMMET	2				
3	90201-05021	WASHER, PLATE	2				
4	95702-05500	NUT, WITH WASHER	2				
5	5UM-83519-E0	BRACKET, METER	1				
6	90105-06110	BOLT, FLANGE	2				
7	5TJ-83755-C0	SENSOR, SPEED	1				
8	93105-47007	.OIL SEAL	1				
9	5TJ-8375F-C0	PLATE 2	2				
10	97702-40010	SCREW, TAPPING	2				
11	5TJ-8375E-C0	PLATE 1	1				
12	92012-05008	BOLT, BUTTON HEAD	2				
13	5UM-83595-E0	CLAMP	1				
14	90105-06105	BOLT, FLANGE	1				
15	5UM-23591-E0	BRACKET 1	1				
16	92012-06012	BOLT, BUTTON HEAD	1				
17	92902-06600	WASHER, PLATE	1				

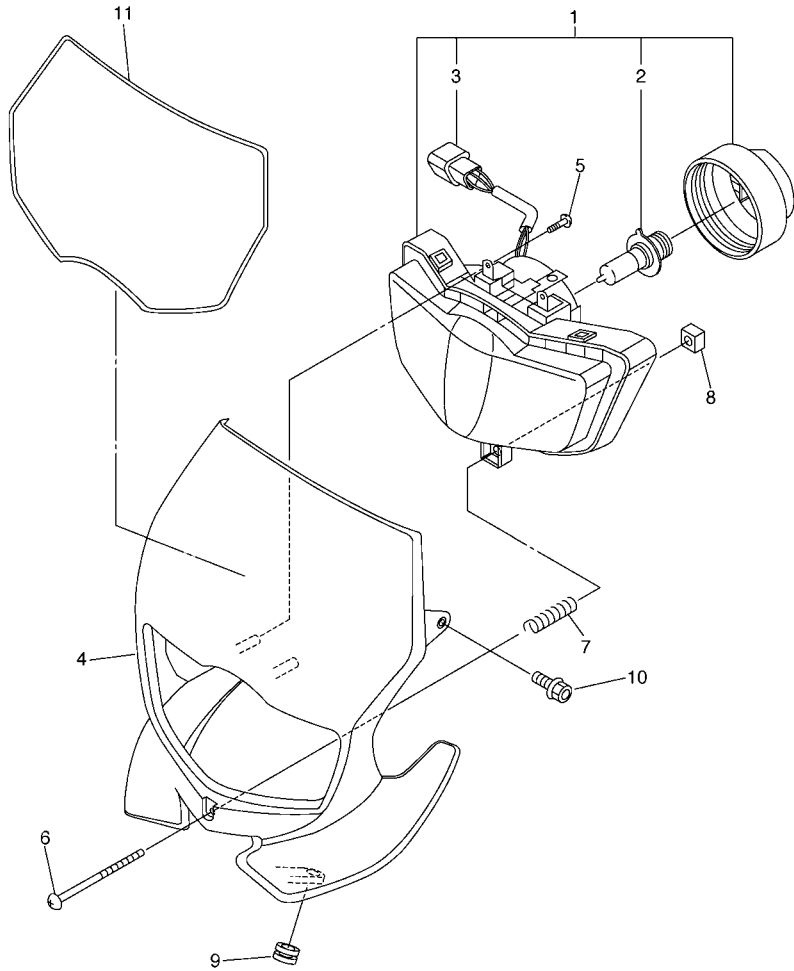


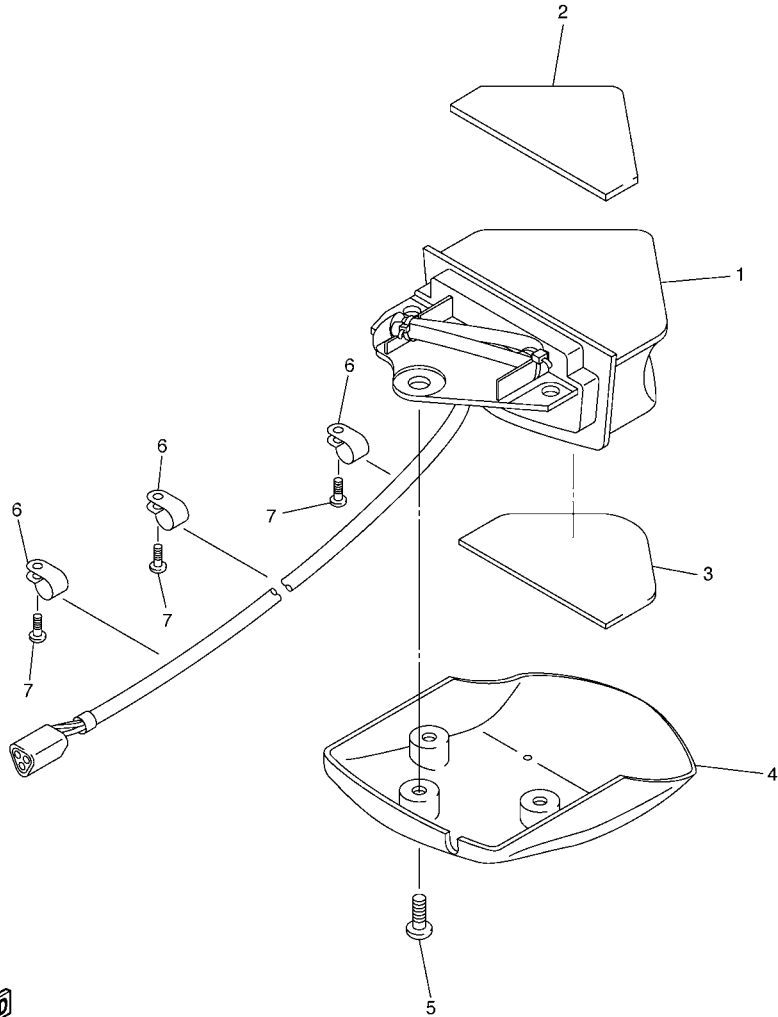
FIG. 41 HEADLIGHT

REF. NO.	PART NO.	DESCRIPTION	SUMM				REMARKS
1	5UM-84310-E1	HEADLIGHT UNIT ASSY	1				
2	5VM-84314-00	.BULB, HEADLIGHT(12V-35/36.5W)	1				HALOGEN
3	5UM-84340-E1	.SOCKET CORD ASSY 1	1				
4	5UM-84330-E0	BODY ASSY	1				
5	97702-50516	SCREW, TAPPING	2				
6	90157-04005	SCREW, PAN HEAD	1				
7	90501-120A3	SPRING, COMPRESSION	1				
8	5BF-84334-00	NUT, ADJUSTING	1				
9	90480-12020	GROMMET	2				
10	90105-06064	BOLT, FLANGE	2				
11	5TJ-2339E-00	GRAPHIC 1	1				



5UME100-F410

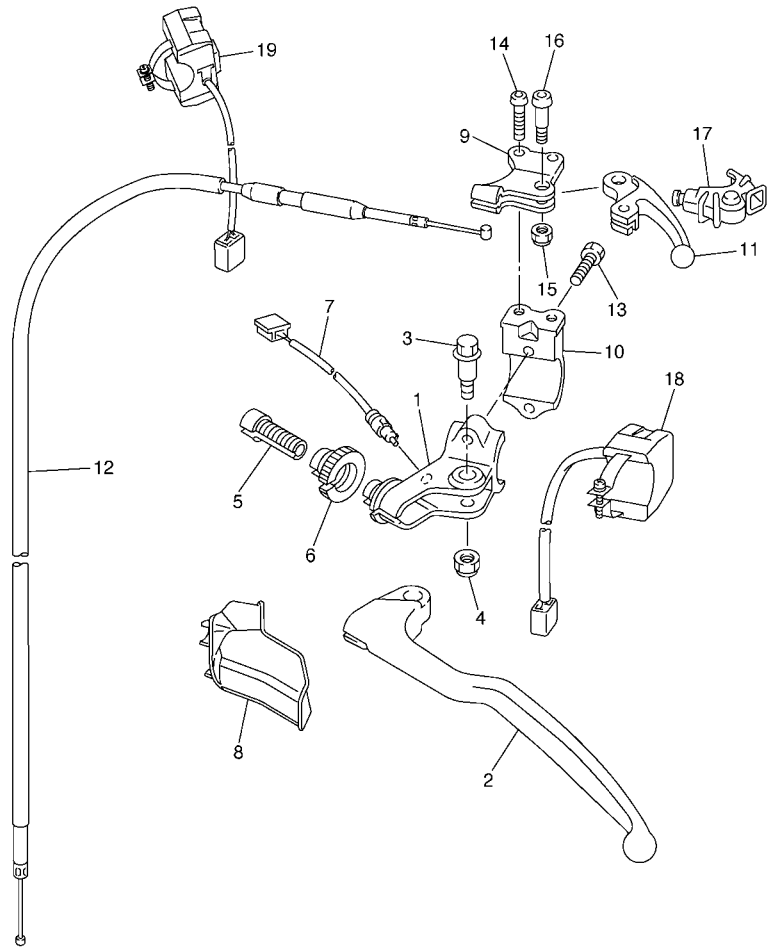
FIG. 42 TAILLIGHT



REF. NO.	PART NO.	DESCRIPTION	SUMM				REMARKS
1	5UM-84710-E0	TAILLIGHT UNIT ASSY	1				
2	5UM-84736-E0	DAMPER, TAIL 1	1				
3	5UM-84737-E0	DAMPER, TAIL 2	1				
4	5UM-84716-E0	COVER, TAILLIGHT	1				
5	97702-50016	SCREW, TAPPING	3				
6	90464-11M18	CLAMP	3				
7	97702-40010	SCREW, TAPPING	3				



5UME100-F420

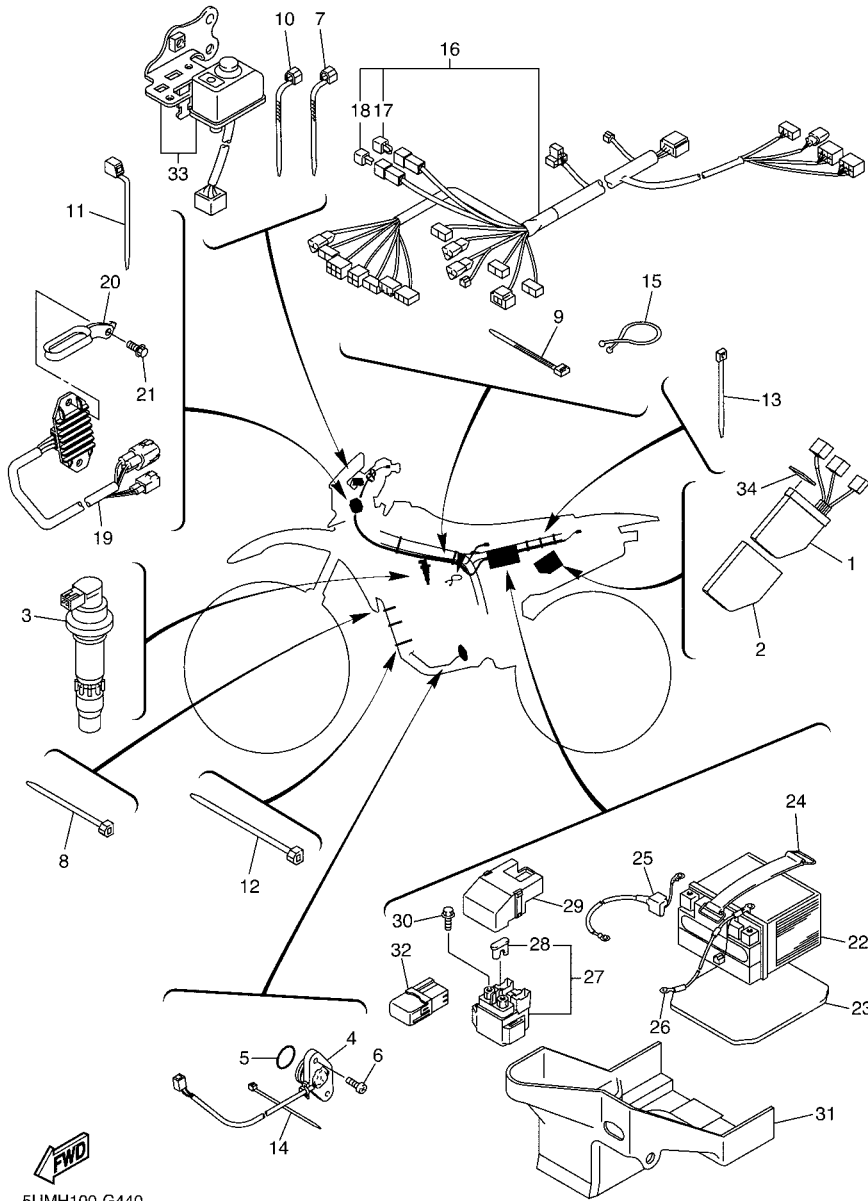


**FIG. 43 HANDLE SWITCH & LEVER**

REF. NO.	PART NO.	DESCRIPTION	SUMM				REMARKS
1	5TJ-82911-80	HOLDER, LEVER 1	1				
2	5TJ-83912-80	LEVER 1	1				
3	90109-06034	BOLT	1				
4	5LP-84126-10	NUT, LENS FITTING	1				
5	5HD-26337-00	BOLT, ADJUSTING	1				
6	5HD-83951-00	BOLT, CABLE ADJUSTING	1				
7	5TJ-82917-02	SWITCH	1				
8	5TJ-26372-80	COVER, HANDLE LEVER 1	1				
9	5XD-82946-00	HOLDER, STARTER LEVER	1				
10	5XD-82913-00	HOLDER, LEVER LOWER 1	1				
11	5TA-83941-00	LEVER, STARTER	1				
12	5UM-26334-E0	CABLE, STARTER 2	1				
13	97002-05016	BOLT	2				
14	92012-05012	BOLT, BUTTON HEAD	2				
15	95602-05100	NUT, U	1				
16	90149-05162	SCREW	1				
17	5TA-26339-00	BOOT	1				
18	5UM-83976-E1	SWITCH, ENGINE STOP	1				
19	5UM-83976-F1	SWITCH, HANDLE 1	1				

  
5UME100-F430

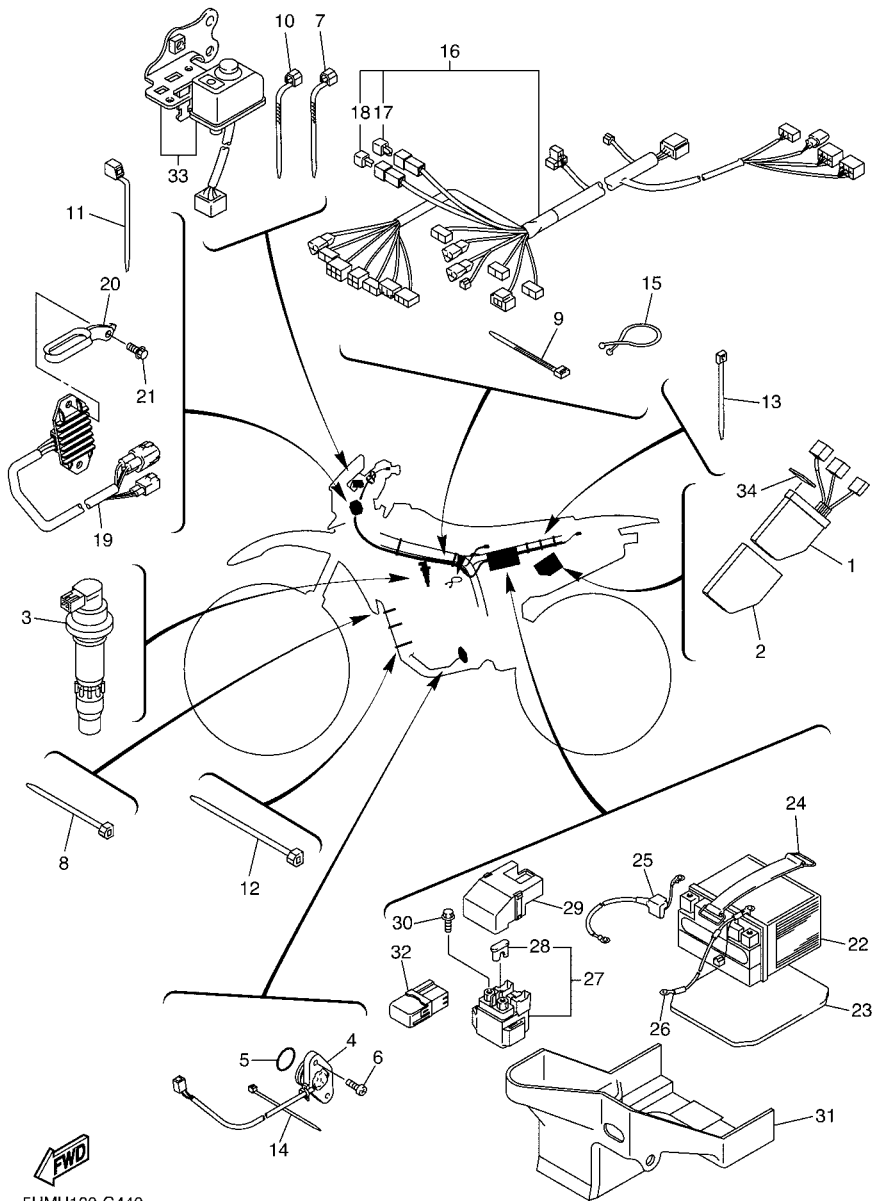




5UMH100-G440

FIG. 44 ELECTRICAL 1

REF. NO.	PART NO.	DESCRIPTION	SUMM				REMARKS
1	5UM-85540-F0	C.D.I. UNIT ASSY	1				
2	5UM-85546-E0	BAND	1				
3	5UL-82310-10	IGNITION COIL ASSY	1				
4	5TJ-82540-01	NEUTRAL SWITCH ASSY	1				
5	93210-21001	O-RING	1				
6	90154-05022	SCREW, BINDING	2				
7	90464-13077	CLAMP	2				
8	90464-15152	CLAMP	3				
9	90465-13275	CLAMP	8				
10	90464-13073	CLAMP	3				
11	90464-16061	CLAMP	2				
12	90464-15195	CLAMP	3				
13	90465-13152	CLAMP	5				
14	5Y9-12491-00	CLAMP 1	2				
15	90464-23041	CLAMP	1				
16	5TJ-82590-E0	WIRE HARNESS ASSY	1				
17	5TJ-81980-00	.DIODE ASSY	1				
18	4WA-81980-00	.DIODE ASSY	1				
19	5UM-81960-E0	RECTIFIER & REGULATOR ASSY	1				
20	5UM-21288-E0	GUIDE, CABLE	1				
21	90105-06110	BOLT, FLANGE	2				
22	5TJ-82100-01	BATTERY ASSY (YTZ7S)	1				
23	5UM-82176-E0	DAMPER	1				
24	8CY-82131-00	BAND, BATTERY	1				
25	5TJ-82115-00	WIRE, PLUS LEAD	1				
26	5UM-82116-E0	WIRE, MINUS LEAD	1				
27	5TJ-81940-12	STARTER RELAY ASSY	1				

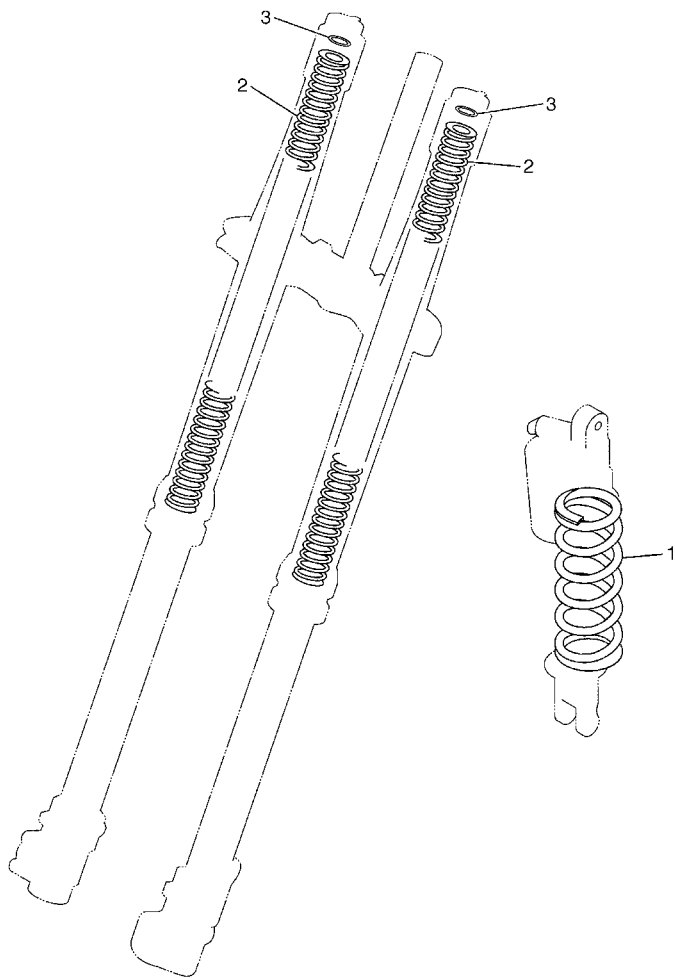


5UMH100-G440

FIG. 44 ELECTRICAL 1

REF. NO.	PART NO.	DESCRIPTION	SUMM				REMARKS
28	42X-82151-00	.FUSE (10A-BL)	2				
29	5SL-82119-10	COVER, LEAD WIRE	1				
30	95022-06008	BOLT, FLANGE	2				
31	5UM-81952-E0	HOLDER, RELAY	1				
32	5UM-81950-E0	RELAY ASSY	1				
33	5UM-82510-E1	MAIN SWITCH ASSY	1				
34	5UM-8235Y-E0	DAMPER	1				

FIG. 45 ALTERNATE FOR CHASSIS



REF. NO.	PART NO.	DESCRIPTION	SUMM				REMARKS
1	5UN-22212-00	SPRING (K=42N/MM)	1				AP
	5UN-22212-10	SPRING (K=44N/MM)	1				AP
	5UN-22212-20	SPRING (K=46N/MM)	1				AP
	5UN-22212-30	SPRING (K=48N/MM)	1				AP
	5UN-22212-40	SPRING (K=50N/MM)	1				AP
	5UN-22212-60	SPRING (K=54N/MM)	1				AP
	5UN-22212-70	SPRING (K=56N/MM)	1				AP
2	5TJ-23141-00	SPRING (K=4.0N/MM)	1				AP
	5TJ-23141-10	SPRING (K=4.1N/MM)	1				AP
	5TJ-23141-20	SPRING (K=4.2N/MM)	1				AP
	5TJ-23141-30	SPRING (K=4.3N/MM)	1				AP
	5TJ-23141-50	SPRING (K=4.5N/MM)	1				AP
	5TJ-23141-60	SPRING (K=4.6N/MM)	1				AP
3	5XE-23364-00	COLLAR 2	1				AP



5XC1100-C390

NUMERICAL INDEX

PART NO.	GRID NO.	PART NO.	GRID NO.	PART NO.	GRID NO.	PART NO.	GRID NO.	PART NO.	GRID NO.	PART NO.	GRID NO.
5UM-11101-10	B - 2	1HX-12168-M1	B - 5	5NL-13411-00	B - 10	5NY-14442-00	B - 13	5XC-14922-00	C - 3	4FN-14997-00	B - 15
5XC-11133-10	B - 2	1HX-12168-R1	B - 5	5XC-13412-00	B - 10	5UM-14451-E0	B - 13	5GS-14933-00	C - 4	5TA-14997-00	C - 3
5NL-11134-10	B - 2	1HX-12168-U1	B - 5	5XC-13416-90	B - 11	5UM-14453-E0	B - 13	3TJ-14933-40	C - 3	5XC-15118-00	C - 9
5UM-11166-00	B - 2	1HX-12168-W1	B - 5	5TA-13440-00	B - 12	5NY-14455-20	B - 13	5TA-14934-00	C - 4	5UM-15150-20-YX	C - 7
371-11167-01	B - 2	1HX-12168-Y1	B - 5	5BE-13447-20	B - 12	5TJ-14458-00	B - 13	5GS-14940-00	C - 4	3Y1-15361-00	C - 9
5NL-11181-00	B - 2	1HX-12169-11	B - 6	5XC-13464-20	B - 10	5TJ-14459-01	B - 13	5JG-14940-16	C - 3	3Y1-15363-00	C - 8
5NL-11191-30	B - 2	1HX-12169-31	B - 6	5XC-13465-10	B - 10	5UM-14462-E0	B - 14	5JG-14940-17	C - 3	5XC-15373-00	C - 8
5NL-11193-00	B - 3	1HX-12169-50	B - 6	5XC-13597-30	B - 13	5TJ-14475-00	B - 13	5JG-14940-18	C - 3	4JT-15381-01	C - 7
5UM-1119E-00	B - 2	1HX-12169-70	B - 6	5UM-14101-E0	B - 15	5JG-14521-00	B - 15	5JG-14940-76	C - 3	5BE-15383-01	C - 7
5XC-11311-10	B - 3	1HX-12169-90	B - 6	5NL-14105-00	C - 3	5JG-14522-00	B - 15	5TA-14943-15	C - 2	5NL-15388-00	C - 7
5NL-11351-00	B - 3	1HX-12169-E0	B - 6	4MX-14115-00	C - 4	5JG-14531-00	C - 4	4MX-14943-39	C - 2	5UM-15411-20	C - 8
5UM-11387-00	B - 3	1HX-12169-G0	B - 6	5TJ-14118-00	C - 4	3TJ-14536-40	C - 3	4MX-14943-40	C - 2	5NL-15415-30	C - 8
5UM-11400-30	B - 4	1HX-12169-J0	B - 6	3TJ-14137-40	B - 13	5JG-14546-01	B - 15	4MX-14943-41	B - 15	5BE-15421-30	C - 7
5UM-11412-20	B - 4	1HX-12169-L0	B - 6			676-14548-00	C - 3	4MX-14943-42	C - 2	5XC-15431-01	C - 8
5UL-11422-10	B - 4	1HX-12169-N0	B - 6	5BE-14146-00	C - 4	4MX-14561-00	C - 4	4MX-14943-43	C - 2	5NL-15441-01	C - 7
5NL-11454-00	B - 4	1HX-12169-T0	B - 6	5PA-14146-00	C - 4	6H4-14561-00	C - 3	4MX-14943-89	B - 15	5UM-15451-00	C - 8
5NL-11455-00	B - 4	5UM-12170-10	B - 7	5TA-14155-00	C - 3	5NX-14562-00	C - 4	4MX-14943-90	C - 2	5NL-15453-10	C - 9
5NL-11531-00	B - 4	5UM-12180-20	B - 7	633-14159-00	C - 3	3TJ-14564-40	C - 3	4MX-14943-91	C - 2	5NL-15462-00	C - 8
5NL-11536-10	B - 4	5TA-12210-20	B - 7	3TJ-14159-40	B - 15	5JG-14565-00	C - 4	4MX-14943-92	C - 2	5UM-1549B-20	C - 8
5NL-11603-00	B - 4	4FM-12213-00	B - 7	5XC-14171-00	C - 3	5GS-14591-00	C - 4	4MX-14943-93	C - 2	5UM-15515-20	C - 11
5NL-11631-20	B - 4	5BE-12241-00	B - 7	3TJ-14191-40	C - 3	688-14592-00	B - 15	4MX-14943-94	C - 2	5UM-15517-00	C - 11
5NL-11633-00	B - 4	5NL-12251-10	B - 7	5UL-14196-00	C - 4	5UM-14611-10	C - 6	5TJ-14947-00	B - 15	5UM-15532-00	C - 11
5XC-11651-00	B - 4	5NL-12252-00	B - 7	5TA-14197-00	C - 4	5NL-14613-00	C - 6	4MX-14948-03	C - 2	5UM-15560-10	C - 11
5XC-11681-00	B - 4	5UM-1240A-E0	B - 9	5NX-14216-00	C - 4	5TJ-14623-00	C - 6	4MX-14948-04	C - 2	5UM-15570-00	C - 11
5NL-12111-20	B - 5	5NL-12422-10	B - 8	5TA-14227-00	B - 13	5XC-14628-00	C - 6	4MX-14948-05	C - 2	5VY-15586-00	C - 11
5NL-12112-20	B - 5	5NL-12439-00	B - 8	5TA-14239-00	B - 13	5UM-14710-E0	C - 6	4MX-14948-06	C - 2	5NL-15601-20	C - 10
5UM-12113-00	B - 5	5XC-1244H-90	B - 9	5TJ-14243-00	C - 4	5PH-14714-00	C - 6	4MX-14948-07	C - 2	5XC-15620-10	C - 10
5NL-12114-00	B - 5	5UM-1244J-E0	D - 7	5TA-14261-00	C - 4	4KM-14714-01	C - 5	4JT-1494F-11	C - 2	5XC-15621-10	C - 10
5NL-12116-00	B - 5	5DH-12451-00	B - 8	5JG-14264-00	B - 15	5BE-14747-00	C - 6	3TJ-1494F-12	C - 2	5NL-15641-20	C - 10
1HX-12117-00	B - 5	5XC-12459-00	B - 8	3TJ-14267-40	B - 15	4BD-14766-00	C - 6	3TJ-1494F-13	C - 2	5NL-15651-00	C - 10
1WG-12117-00	B - 5	5UM-12461-E0	B - 9	5JG-14275-00	B - 15	5TJ-14780-00	C - 6	3TJ-1494F-14	C - 2	5NL-15664-00	C - 10
1HX-12118-00	B - 5	22W-12462-00	B - 9	5TA-14293-00	B - 13	5TJ-14784-00	C - 6	3TJ-1494F-15	C - 2	5SG-15668-00	C - 10
1WG-12118-00	B - 5	2S2-12464-70	B - 9	3TJ-14293-40	C - 3	5BE-14788-00	C - 6	4JT-1494F-15	C - 2	2S2-15671-00	C - 10
4SV-12119-00	B - 5	5XC-12481-90	B - 9	5TA-14335-00	C - 3	5TJ-14799-00	C - 6	3TJ-1494F-16	C - 2	214-15686-00	C - 10
4TV-12119-00	B - 5	1C3-12482-00	B - 9	5JG-14346-00	C - 4	5UM-14803-00	C - 5	4JT-1494F-19	C - 2	5NL-16111-01	C - 12
5NL-12121-10	B - 5	5XC-12482-90	B - 9	5TA-14371-00	C - 3	5UM-14834-E0	C - 5	4JT-1494F-23	C - 2	5NL-16150-10	C - 12
3GM-12126-00	B - 5	5Y9-12491-00	F - 4	2S2-14374-00	C - 3	5UM-14871-10	C - 5	4JT-1494F-27	C - 2	5NL-16154-00	C - 12
3FV-12153-10	B - 6	5NL-12564-00	C - 8	5JG-14379-00	C - 3	5UM-14881-00	C - 5	4JT-1494F-29	C - 2	3XJ-16321-00	C - 12
3LN-12153-10	B - 6	5XC-12576-90	B - 9	2S2-14388-00	B - 15	5UM-14882-00	C - 5	5UM-1494F-30	C - 2	5DH-16321-00	C - 12
1HX-12168-00	B - 5	5XC-12578-90	B - 9	4MX-14392-00	C - 3	5UM-14916-B1	B - 15	4JT-1494F-31	C - 3	5NL-16325-00	C - 12
1HX-12168-20	B - 5	5XC-12579-91	B - 9	5UM-14401-E0	B - 13	5UM-14916-BN	B - 15	5JG-14951-00	B - 15	5NL-16325-10	C - 12
1HX-12168-40	B - 5	583-13113-00	B - 12	5UM-14417-E0	B - 13	5UM-14916-BP	B - 15	5GS-14958-00	C - 4	5HD-16351-00	C - 12
1HX-12168-60	B - 5	5NL-13116-20	B - 12	5TJ-14419-00	B - 14	5UM-14916-BR	B - 15	5JG-14959-00	B - 15	5XC-16356-00	C - 12
1HX-12168-80	B - 5	5NL-13171-00	B - 12	5UM-1441A-E0	B - 14	5UM-14916-BS	B - 15	5JG-14984-00	C - 3	5NL-16357-10	C - 12
1HX-12168-A0	B - 5	5SG-13300-00	B - 10	5UM-1441G-E0	B - 13	5UM-14916-BT	B - 15	4SR-14985-00	C - 3	5NL-16371-00	C - 12
1HX-12168-F0	B - 5	5NL-13320-00	B - 10	5UM-14437-E0	B - 13	5UM-14916-BU	B - 15	5TA-14987-00	B - 13	5JG-16381-10	C - 12
1HX-12168-H1	B - 5	5NL-13341-00	B - 10	5UM-1443A-E0	B - 13	5UM-14916-BV	B - 15	5TJ-14987-00	C - 4	5NL-16383-10	C - 12
1HX-12168-K1	B - 5	5BE-13342-00	B - 10	5BF-1443E-00	B - 13	5UM-14916-RU	B - 15	5TA-14991-00	C - 3	4JT-16384-00	C - 12

NUMERICAL INDEX

PART NO.	GRID NO.	PART NO.	GRID NO.	PART NO.	GRID NO.	PART NO.	GRID NO.	PART NO.	GRID NO.	PART NO.	GRID NO.
5NL-16384-00	C - 12	5UM-21486-E0	D - 5	5UN-22212-00	F - 6	1C3-2315H-10	D - 13	4XM-25364-00	E - 5	5DH-25919-00	E - 4
5NL-17121-00	C - 14	1C3-21511-51	D - 6	5UN-22212-10	F - 6	5TJ-2315J-C0	D - 13	1C3-25381-90	E - 6	5DH-25919-50	E - 7
5UM-17131-00	C - 14	4XL-2153A-10	D - 13	5UN-22212-20	F - 6	5UM-2316A-F0	D - 12	1C3-25388-50	E - 6	8CR-25924-00	E - 7
5UM-17141-00	C - 14	5UM-2153E-00	D - 6	5UN-22212-30	F - 6	5UM-23170-E0	D - 12	1C3-25389-00	E - 6	3SP-25926-51	E - 4
5UM-17151-00	C - 14	4ES-2153E-01	D - 6	5UN-22212-40	F - 6	5XE-23171-L0	D - 12	3JE-25394-00	E - 5	5DH-25933-00	E - 4
5PH-17211-00	C - 14	5PA-21568-00	D - 6	5UN-22212-50	D - 10	5DH-23183-00	D - 10	4XM-25394-00	E - 5	1UY-25937-51	E - 4
5NL-17221-00	C - 14	5UM-21610-E0	D - 6	5UN-22212-60	F - 6	509-23184-L0	D - 10	5SF-25394-00	E - 3		
5UM-17231-00	C - 14	5XE-21635-10	D - 6	5UN-22212-70	F - 6	5TJ-2331E-80	D - 11	1C3-25448-00	E - 5	5XC-26111-L0	E - 8
5UM-17241-00	C - 14	5UM-2163G-20	D - 6	3SP-22213-00	D - 10	5UM-23340-L0	D - 13	5GS-25448-50	E - 5	5XC-26124-90	E - 8
5UM-17251-00	C - 14	5TA-21642-00	D - 6	5XE-22214-00	D - 10	3SP-23356-L0	D - 13	1C3-25449-00	E - 5	5XC-26143-L0	E - 8
5NL-17402-00	C - 14	3RV-21668-A0	D - 9	5MV-22224-00	D - 10	5XE-23364-00	F - 6	1C3-25450-00	E - 5	5TJ-26240-C0	E - 8
5UM-17411-00	C - 14	5UM-21711-E0	D - 7	4JX-22226-00	D - 10	5TJ-23389-80	D - 11	5TJ-25450-80	E - 5	4GY-26241-00	E - 8
5NL-17466-00	C - 7	5UM-21717-E0	D - 7	3SP-22234-00	D - 10	5XE-23393-L0	D - 12	1C3-25451-00	E - 5	5BE-26281-00	E - 8
5NL-17471-10	C - 15	5XC-21719-90	D - 7	5NY-22241-00	D - 10	5TJ-2339E-00	E - 15	1C3-25452-00	E - 5	5BE-26282-00	E - 8
5UL-18101-10	D - 3	5UM-21721-E0	D - 7	5XE-22242-00	D - 10	4EW-23416-00	D - 11	5TJ-25452-80	E - 5	5SF-26287-10	E - 8
5XC-18110-00	D - 3	2S2-2172A-70	D - 7	5MV-22253-00	D - 10	5UM-23435-E1	D - 11	5CG-25715-00	E - 9	5UM-26302-E0	E - 8
5LP-18122-01	D - 3	2S2-2172A-80	D - 7	1C3-22253-50	D - 10	5XC-23441-90	D - 11			5UM-26334-E0	F - 3
3XK-18140-00	D - 2	5UM-2172S-E0	D - 7	4AA-22259-40	D - 10	5UM-23442-E0	D - 11	1C3-25718-50	E - 7	5UM-26335-E0	E - 8
5BE-18172-00	D - 3	5UM-21730-E0	D - 7	1P8-22355-00	D - 8	5XC-23466-L0	D - 13	1C3-2580T-00	E - 4	5HD-26337-00	F - 3
3XJ-18173-10	D - 3	5TJ-2173L-00	D - 7	4EW-22474-00	D - 10	5XC-23467-L0	D - 13	1C3-2580W-71	E - 7	5TA-26339-00	F - 3
3XJ-18178-00	D - 3	5UM-2173S-E0	D - 7	3JE-22475-00	D - 10	5TJ-23525-C0	D - 13	2S2-2581T-70	E - 4	1C3-26342-50	E - 8
3XJ-18182-00	D - 3	5UM-21740-E0	D - 7	5NY-22475-00	D - 10	5UM-23591-E0	E - 14	5UN-25827-60	E - 7	5NY-26372-00	E - 9
3XJ-18184-00	D - 3	5UM-2174A-E0	D - 7	5UN-22898-60	E - 7	5UM-24110-E1	D - 14	5UN-25828-60	E - 7	5TJ-26372-80	F - 3
2S2-18185-00	D - 3	5TJ-2174L-00	D - 7	1C3-22969-90	D - 8	4EW-2412F-00	D - 14	2S2-2582W-70	E - 7	5XC-27200-A0	E - 10
5NL-18501-00	D - 2	5UM-2174T-E0	D - 6	5UM-23102-F0	D - 12	5XE-24144-00	D - 14	5MV-25833-00	E - 9	5UN-27217-00	E - 11
5NL-18502-00	D - 2	5XC-21751-90	B - 11	5UM-23103-F0	D - 12	5UM-24181-E0	D - 14	1C3-2583V-00	E - 11	5XC-27217-90	E - 10
5NL-18503-00	D - 2	2TK-21757-00	B - 14	5TJ-23110-C0	D - 12	5XC-24182-90	D - 14	5DH-25849-00	E - 4	5UN-27218-00	E - 11
5NL-18541-00	D - 2	5TJ-21757-00	B - 14	5XE-23111-L0	D - 12	5XC-24183-90	D - 14	5MV-25852-01	E - 9	5UN-27222-00	E - 11
4UN-18542-00	D - 2	4XV-2177L-01	B - 13	5UM-23113-E0	D - 11	3JD-24186-00	D - 14	5UN-25852-50	E - 11	5UM-27311-E0	E - 10
5DH-18562-00	C - 7	5UM-21860-E0	D - 7	5XE-23117-L0	D - 12	5UM-2419A-E0	D - 14	5XE-25853-00	E - 9	5UM-27315-E0	E - 10
5UM-21101-E0	D - 4	26H-21874-00	D - 7	5TJ-23120-C0	D - 12	5UM-24311-E0	D - 14	5UN-25854-00	E - 11	5XC-27411-M0	E - 10
5UM-21190-E0	D - 4	26H-21875-00	D - 7	5XE-23125-L0	D - 12	5XC-24339-90	D - 14	5XE-25854-00	E - 9	5XC-27421-M0	E - 10
1C3-21244-10	D - 15	2S2-22110-70	D - 8	3JD-2312G-L0	D - 12	3XJ-24380-00	D - 14	5UN-2585B-00	E - 11	1C3-27491-50	E - 7
5UM-21268-E0	D - 5	5XC-22121-91	D - 9	5TJ-23136-C0	D - 12	5UM-24500-E0	D - 14	5MV-25867-00	E - 9	5XC-28116-00	D - 5
5XC-21288-90	D - 5	1C3-22122-00	D - 9	5TJ-23141-00	F - 6	1P6-24512-00	D - 14	5NY-25868-00	E - 9	5TA-2814F-00	D - 5
5UM-21288-E0	F - 4	2S2-22128-70	D - 8	5TJ-23141-10	F - 6	5NY-24610-00	D - 14	5TJ-25872-80	E - 9	5ET-28166-10	D - 5
1C3-2135F-00	D - 9	1C3-22141-10	D - 8	5TJ-23141-20	F - 6	5UM-2470F-E0	E - 2	5XC-25873-L0	E - 11	5UM-2831V-E0	D - 11
1C3-2139R-00	D - 9	2S2-22151-70	D - 8	5TJ-23141-30	F - 6	5UM-24710-E0	E - 2	1C3-25875-50	E - 4	3FV-28386-00	B - 14
5UM-21417-E0	D - 5	5UM-22176-00	D - 10	5TJ-23141-50	F - 6	5UM-24723-E0	E - 2	1C3-25876-50	E - 11	5UM-81410-30	E - 12
5UM-21418-E0	D - 5	30X-22178-00	D - 4	5TJ-23141-60	F - 6	5NY-25104-00	E - 3	1C3-25886-50	E - 11	5UM-81450-00	E - 12
5UM-21425-E0	D - 4	3JD-22178-20	D - 4	5TJ-23141-A0	D - 12	5TJ-2510C-80	E - 3	5MV-2589F-00	E - 9	5UM-81528-00	C - 9
5UM-21426-E0	D - 4	5XC-2217A-90	D - 8	5XE-23142-L0	D - 12	5NG-25111-50	E - 3	5UN-25914-00	E - 7	5UM-81801-10	E - 13
5UM-21447-E0	D - 4	5XC-2217F-90	D - 8	5XE-23144-L0	D - 12	5NY-25117-00	E - 3	5DH-25914-50	E - 7	5TJ-81828-01	E - 13
1C3-21448-10	D - 4	4V4-22184-00	D - 4	1C3-23145-L0	D - 12	1C3-25181-10	E - 3	3SP-25914-51	E - 4	5UM-81828-10	E - 13
5UM-21455-E0	D - 5	5MV-22184-00	D - 10	5XE-23146-L0	D - 12	5GS-25304-00	E - 5	5DH-25916-00	E - 4	5UM-8183G-20	E - 13
5XC-21456-90	D - 5	5UM-22199-E0	D - 8	1C3-2314F-M0	D - 12	5TJ-2530S-80	E - 6			5UM-81861-00	E - 13
5UM-2147A-E0	D - 5	5UM-22201-G0	D - 10	5XE-23153-L0	D - 12	5ET-25311-00	E - 5	3JD-25917-00	E - 4	5UM-81890-10	E - 13
5UM-21485-E0	D - 5	5UM-22210-G0	D - 10	4SS-23158-L0	D - 12	5ET-25317-00	E - 5			5TJ-81940-12	F - 4

NUMERICAL INDEX

PART NO.	GRID NO.	PART NO.	GRID NO.	PART NO.	GRID NO.	PART NO.	GRID NO.	PART NO.	GRID NO.	PART NO.	GRID NO.
5UM-81950-E0	F - 5	5MV-W0045-01	E - 4	90105-08147	D - 4	90179-18001	C - 12	90201-24016	D - 11	90430-10005	E - 9
5UM-81952-E0	F - 5	1C3-W0046-B0	E - 7	90105-08150	D - 4		C - 15	90201-286K9	D - 11		E - 11
5UM-81960-E0	F - 4	3JD-W0047-00	E - 4	90105-08151	B - 11	90179-28003	D - 11	90202-05193	D - 14	90430-10188	B - 12
4WA-81980-00	F - 4	5UN-W0047-50	E - 7	90105-08154	D - 11	90183-060A6	B - 9	90202-08045	B - 15		C - 7
5TJ-81980-00	F - 4	1UY-W0048-50	E - 4	90105-08156	D - 4	90185-08008	E - 6	90206-06090	C - 6	90445-08027	C - 5
5TJ-82100-01	F - 4		E - 7	90105-08307	C - 6	90185-08009	D - 4	90209-16011	D - 8	90445-09220	D - 14
5TJ-82115-00	F - 4	5UN-W0057-00	E - 4		D - 4	90185-10012	D - 10	90209-20008	C - 14	90445-09251	D - 14
5UM-82116-E0	F - 4	5UN-W0057-50	E - 7	90105-09002	B - 2	90185-10018	E - 10	90209-20008	C - 14	90445-14010	B - 11
5SL-82119-10	F - 5	5XE-W2587-10	E - 9	90105-09004	B - 2	90185-14010	D - 9	90215-14204	B - 4	90445-217G3	E - 10
8CY-82131-00	F - 4	90101-06041	D - 3	90105-10174	D - 4	90185-16002	D - 8	90215-16289	C - 12	90450-17001	B - 11
42X-82151-00	F - 5	90101-06044	C - 10	90105-10176	D - 5	90185-20002	E - 6	90215-20003	C - 12	90450-20078	C - 5
5UM-82176-E0	F - 4	90101-08006	E - 6	90105-10191	D - 4	90201-05021	E - 14		C - 15	90450-22001	B - 9
5UL-82310-10	F - 4	90105-05014	D - 5	90109-06034	F - 3	90201-06032	D - 6	90240-08120	E - 10		B - 10
5UM-8235Y-E0	F - 5	90105-05016	D - 11	90109-060E9	C - 5	90201-06084	D - 6	90240-10004	E - 10	90450-25001	B - 9
5UM-82510-E1	F - 5	90105-06027	B - 2	90109-06193	D - 2	90201-06570	D - 14	90249-05004	B - 14	90450-32003	B - 9
5TJ-82540-01	F - 4	90105-06064	D - 7	90109-06245	B - 14	90201-06571	B - 9	90249-05005	B - 14	90450-57010	B - 13
5TJ-82590-E0	F - 4		E - 15	90109-08078	E - 5		B - 11	90280-03006	B - 4	90450-61002	B - 13
5TJ-82911-80	F - 3	90105-06081	C - 7	90109-10026	E - 10		D - 6	90338-07043	B - 13	90464-11M18	F - 2
5XD-82913-00	F - 3		C - 15	90110-05038	B - 13	90201-06630	B - 11	90340-12007	B - 2	90464-13073	F - 4
5TJ-82917-02	F - 3	90105-06094	C - 9	90110-05041	C - 6	90201-08043	D - 4	90340-14015	C - 8	90464-13077	F - 4
5XD-82946-00	F - 3	90105-06098	C - 9	90110-06228	B - 12	90201-08044	E - 10	90340-27004	C - 8	90464-15152	F - 4
5TJ-83500-F0	E - 14	90105-06100	D - 6	90110-08051	C - 10	90201-08045	D - 4	90387-06009	D - 6	90464-15195	F - 4
5UM-83519-E0	E - 14	90105-06103	D - 7	90111-06059	E - 11	90201-08048	C - 10	90387-06065	B - 9	90464-16061	F - 4
5UM-83595-E0	E - 14	90105-06104	D - 8	90116-06038	B - 2		E - 6		D - 14	90464-23041	F - 4
5TJ-83755-C0	E - 14	90105-06105	C - 5	90119-06146	D - 7	90201-08061	C - 6	90387-06090	D - 6	90465-10013	C - 7
5TJ-8375E-C0	E - 14		D - 8	90119-06147	D - 6	90201-080H1	C - 12		D - 14	90465-13152	F - 4
5TJ-8375F-C0	E - 14		E - 4	90119-06166	D - 5	90201-082A6	B - 11	90387-06104	D - 11	90465-13275	D - 14
5TJ-83912-80	F - 3		E - 14	90119-08095	D - 7	90201-08410	C - 3	90387-06150	B - 11		F - 4
1C3-83922-50	E - 9	90105-06106	D - 6	90149-05162	F - 3	90201-08512	B - 8	90387-06161	B - 11	90467-07138	C - 5
5TA-83941-00	F - 3	90105-06107	C - 5	90149-06074	C - 7	90201-089J9	B - 2	90387-08041	D - 4	90467-09006	C - 5
5HD-83951-00	F - 3		D - 11	90149-06084	B - 4	90201-10032	E - 10	90387-08081	C - 6	90467-090A2	B - 9
5UM-83976-E1	F - 3		D - 14	90149-06108	D - 14	90201-10045	D - 4	90387-086N4	D - 4		D - 7
5UM-83976-F1	F - 3		E - 7	90149-10031	D - 4		E - 10	90387-1003G	E - 10	90467-100A1	D - 14
5LP-84126-10	F - 3	90105-06108	E - 7	90151-04003	D - 8	90201-104R2	C - 11	90387-124F4	D - 3	90467-140A4	B - 2
5UM-84310-E1	E - 15	90105-06110	E - 7	90151-06044	C - 7	90201-12020	E - 12	90387-14009	D - 9		C - 5
5VM-84314-00	E - 15		E - 14	90151-06051	E - 4	90201-12166	B - 10	90387-16010	D - 8	90467-16063	C - 5
5UM-84330-E0	E - 15		F - 4	90152-06010	C - 10	90201-12790	B - 2	90387-18004	D - 8	90467-17089	B - 2
5BF-84334-00	E - 15	90105-06111	B - 9	90154-05022	F - 4	90201-14020	D - 9	90387-18007	C - 7		B - 14
5UM-84340-E1	E - 15		D - 14	90157-04005	E - 15	90201-15701	C - 8	90387-18012	D - 8		C - 5
5UM-84710-E0	F - 2		E - 7	90159-06092	C - 12	90201-16018	D - 8	90387-20006	C - 14	90468-16001	E - 10
5UM-84716-E0	F - 2	90105-06112	B - 11	90170-14171	B - 4	90201-162H4	C - 10	90387-22001	C - 14	90480-10289	B - 11
5UM-84736-E0	F - 2	90105-06127	D - 6	90170-16326	C - 12	90201-167P7	C - 10	90401-08006	B - 12	90480-12020	E - 15
5UM-84737-E0	F - 2	90105-06128	B - 11	90170-24003	D - 11	90201-177G4	C - 10	90401-10015	B - 12	90480-14012	E - 14
5UM-85540-F0	F - 4	90105-08133	D - 4	90179-06028	D - 8	90201-20020	E - 6	90401-10172	E - 9	90480-14433	B - 11
5UM-85546-E0	F - 4	90105-08134	D - 13	90179-08019	E - 6	90201-20021	C - 11		E - 11	90480-15528	B - 9
5XC-85885-00	C - 4	90105-08137	C - 6	90179-10658	D - 4	90201-203L1	C - 11	90430-06014	B - 2	90480-18549	D - 14
5NY-W0041-00	E - 9		E - 4	90179-12657	E - 12	90201-20685	C - 10		B - 8	90501-043E0	B - 12
5UN-W0042-50	E - 11	90105-08143	D - 5	90179-16011	E - 3	90201-21014	D - 8	90430-08119	B - 12	90501-052G5	D - 3

NUMERICAL INDEX

PART NO.	GRID NO.	PART NO.	GRID NO.	PART NO.	GRID NO.	PART NO.	GRID NO.	PART NO.	GRID NO.	PART NO.	GRID NO.
90501-06022	D - 2	93102-12224	C - 12	93315-32166	D - 8	95022-06012	B - 12	99530-08016	C - 8		
90501-120A3	E - 15		D - 3	93315-32269	D - 8	95022-06016	B - 10	99530-10114	B - 10		
90501-147A5	C - 10	93102-18278	C - 10	93317-11287	C - 12		C - 8		C - 7		
90501-160A2	C - 10	93102-26468	E - 3	93317-22262	D - 8	95022-06020	D - 3	99530-10116	C - 7		
90501-220A0	C - 12	93102-28010	C - 14	93332-00068	D - 11	95022-06025	B - 7	9Y58A-76113	E - 6		
90506-16007	E - 10	93105-47007	E - 14	93332-00081	D - 11		B - 8				
90506-30005	E - 10	93106-22002	D - 8	93340-21008	C - 12		B - 10				
90508-26561	D - 2	93106-30001	E - 5	93342-22217	D - 8		C - 8				
90508-28015	E - 10	93106-30045	E - 5	93410-20038	C - 10	95022-06030	C - 8				
90508-28018	E - 10	93109-11073	B - 8	93410-22039	C - 14	95022-06035	B - 3				
90508-291A8	D - 3	93109-22019	D - 9	93410-26067	C - 14		C - 8				
90508-30743	C - 10	93109-25001	D - 8	93420-16086	B - 4	95022-06040	C - 8				
91312-05012	C - 9	93109-28043	D - 8	93440-07149	B - 2	95022-06065	B - 8				
91312-05020	E - 12	93210-07003	B - 12	93440-07182	B - 8	95022-08040	D - 4				
91312-06012	B - 9	93210-07135	B - 12		C - 12	95022-10016	C - 7				
91312-06014	E - 12	93210-09008	B - 12	93440-10153	B - 2	95602-05100	F - 3				
91312-06016	B - 11	93210-09754	B - 11		B - 10	95602-10200	D - 10				
91312-06025	B - 10	93210-10197	B - 10	93440-41178	B - 7		D - 11				
	B - 12		C - 7	93503-08007	B - 12	95612-08620	B - 2				
	B - 13	93210-11073	E - 10	93507-32009	C - 10	95701-06500	E - 9				
	C - 11	93210-12759	B - 12	93511-32027	C - 12	95702-05500	E - 14				
	E - 13	93210-14369	B - 11	93603-16219	B - 10	95702-06500	B - 3				
91312-06045	C - 7		C - 8	93604-10011	B - 8		D - 13				
91312-06055	C - 7	93210-15414	B - 9	93608-33002	D - 3	95702-08500	C - 6				
91312-06065	B - 12	93210-16716	C - 8	93612-16254	B - 3	97002-05016	F - 3				
91312-06070	C - 7	93210-17570	C - 10		C - 7	97022-06016	B - 7				
91312-06100	C - 7	93210-19123	C - 8	9383B-13218	C - 14	97702-40010	E - 14				
91312-06110	C - 8	93210-196A4	C - 14	9383B-14222	C - 14		F - 2				
91316-04012	B - 15	93210-21001	F - 4	94108-21015	E - 3	97702-50016	F - 2				
91317-06030	B - 10	93210-25711	E - 13	94109-21009	E - 3	97702-50516	B - 13				
91402-20012	E - 10	93210-27370	C - 8	94110-18009	E - 5		E - 15				
91402-25015	E - 10	93210-47675	B - 12	94113-18015	E - 5	97702-60016	D - 6				
91808-16023	B - 2	93210-60426	C - 8	94211-18176	E - 5	98502-04010	C - 4				
91812-16001	C - 8	93300-60839	D - 4	94213-18012	E - 5	98502-05010	E - 11				
91A20-05140	B - 9	93306-00105	B - 8	94227-21101	E - 3	98502-05020	E - 8				
92012-05008	C - 6	93306-00317	C - 14	94309-18146	E - 5	98502-06025	C - 7				
	E - 14	93306-00320	C - 14	94309-21161	E - 3	98702-06025	D - 14				
92012-05012	F - 3	93306-07202	E - 5	94416-21005	E - 3	98706-04012	E - 9				
92012-06010	B - 9	93306-20335	B - 4	94418-18006	E - 5	98980-06008	C - 6				
92012-06012	E - 14	93306-20447	C - 14	94421-18005	E - 5	99001-08600	B - 10				
92902-04100	C - 4	93306-20648	B - 4	94591-53114	B - 7	99002-04600	B - 14				
92902-06600	B - 7	93306-27208	C - 14	94681-76021	E - 6	99009-12400	B - 10				
	E - 14	93306-27212	E - 5	94701-00410	B - 2	99009-16400	C - 10				
92902-08200	D - 5	93306-90409	E - 3	94701-00411	B - 2	99009-17400	C - 10				
92902-10200	D - 10	93306-90509	D - 2	95022-06008	F - 5	99009-22500	C - 8				
	D - 11	93310-42057	C - 11	95022-06010	B - 2	99009-45500	E - 5				
93101-14164	C - 8	93310-63238	B - 4		C - 13	99530-08012	B - 10				
93102-12106	B - 8	93311-32261	B - 4	95022-06012	B - 8		C - 11				