



# PARTS CATALOGUE

WR400FL	(5GS1)	U.S.A.
WR400F'99	(5GS2)	EUROPE
WR400F	(5GS3)	JAPAN
WR400FL	(5GS4)	OCEANIA,CANADA,S.AFRICA

---



A3

# FOREWORD

This Parts Catalogue is related to the parts for the model(s) in the below frame. When you are ordering replacement parts, please refer to this Parts Catalogue and quote both part numbers and part names correctly.

WR400FL(5GS1/5GS4),WR400F'99(5GS2),WR400F(5GS3)

1. Modifications or additions which have been made after issue of the Parts Catalogue will be announced in the Yamaha Parts News. It is advisable that you make necessary corrections to the Parts Catalogue according to the Yamaha Parts News.

## 2. Abbreviations

The Following abbreviations are used in this Parts Catalogue.

"UR" Use specified parts number.

"UN" Use as many as needed.

"AP" Alternate Parts

"LM" Local Made (Parts need to be ordered locally)

"F#" Frame No. (Applicable machine No.)

3. Parts, which are to be supplied in an assembly, are listed with a dot(.) in front of the part name as shown below.

### EXAMPLE

CARBURETOR ASSY

.JET, PILOT

.NOZZLE, MAIN

4. Number of component for assembly

The numeral appearing to the right of each component part indicates the quantity of parts for each assembly unit.

### EXAMPLE

PART NO.	DESCRIPTION	Q'TY	REMARKS
2F5-83310-60	FRONT FLASHER LIGHT ASSY	2	
115-83311-60	.BULB (6V-18W)	1	
1M1-83309-60	.REFLECTOR	1	

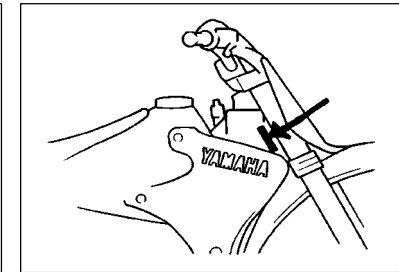
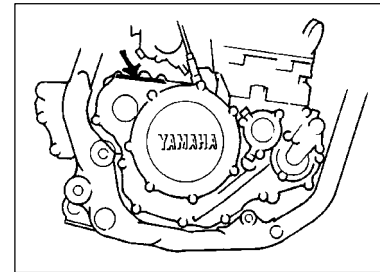
5. Applicable colors of graphics are represented in the "REMARKS" as shown below.

PART NO.	DESCRIPTION	Q'TY	REMARKS
2N4-24110-00-X5	.FUEL TANK COMP.	2	MXR
3J1-24240-10	.GRAPHIC, FUEL TANK	1	for MXR

6. Applicable Serial No.

Engine Serial No.

Frame Serial No.

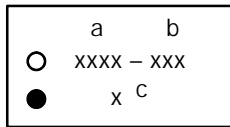


7. Note that the illustrations for reference in funding parts numbers, not to be used for assembling. When assembling, please use the applicable service manual.
8. The asterisk (\*) before a reference number indicates modification items after the first edition.

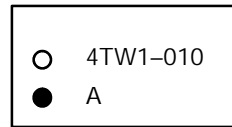
# MODEL LABEL

(1) A label called "Model Label" is affixed in the location as indicated in (3) below.  
When using this parts catalogue, please be sure to cross-refer the "model code – production code No." in the catalogue to the "model code – production code No." indicated on the Model Label affixed onto the product concerned.

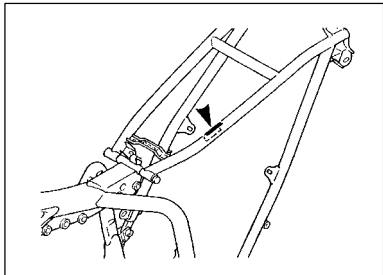
(2) "Model Label" Indication



a: Model Type Code  
b: Production Code No.  
c: Colouring Type



(3) Model Label Affixing Location

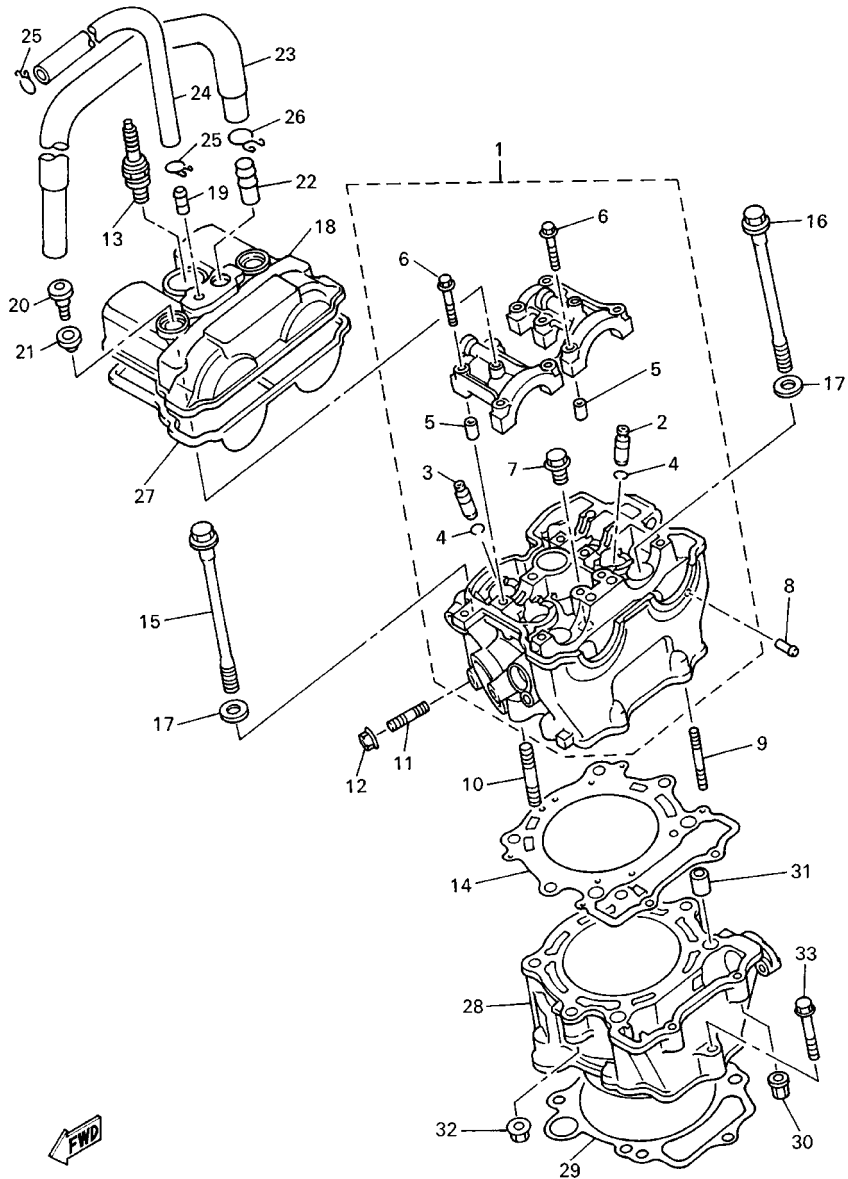


(4) Model Code – Production Code Number of Model Listed in This Parts Catalog

Model Code	Production Code No.	Country (destination)	Model Code	Production Code No.	Country (destination)
5GS1	010	U.S.A.	5GS4	030	NEWZEALAND
	010	FRANCE		040	S.AFRICA
	020	BELGIUM			
	030	GERMANY			
	040	SPAIN			
	050	FINLAND			
	050	IRELAND			
	060	ENGLAND			
	070	GREECE			
	080	ITALY			
5GS2	090	PORTUGAL			
	100	SWEDEN			
5GS3	010	JAPAN			
5GS4	010	AUSTRALIA			
	020	CANADA			

(5) Colouring Information

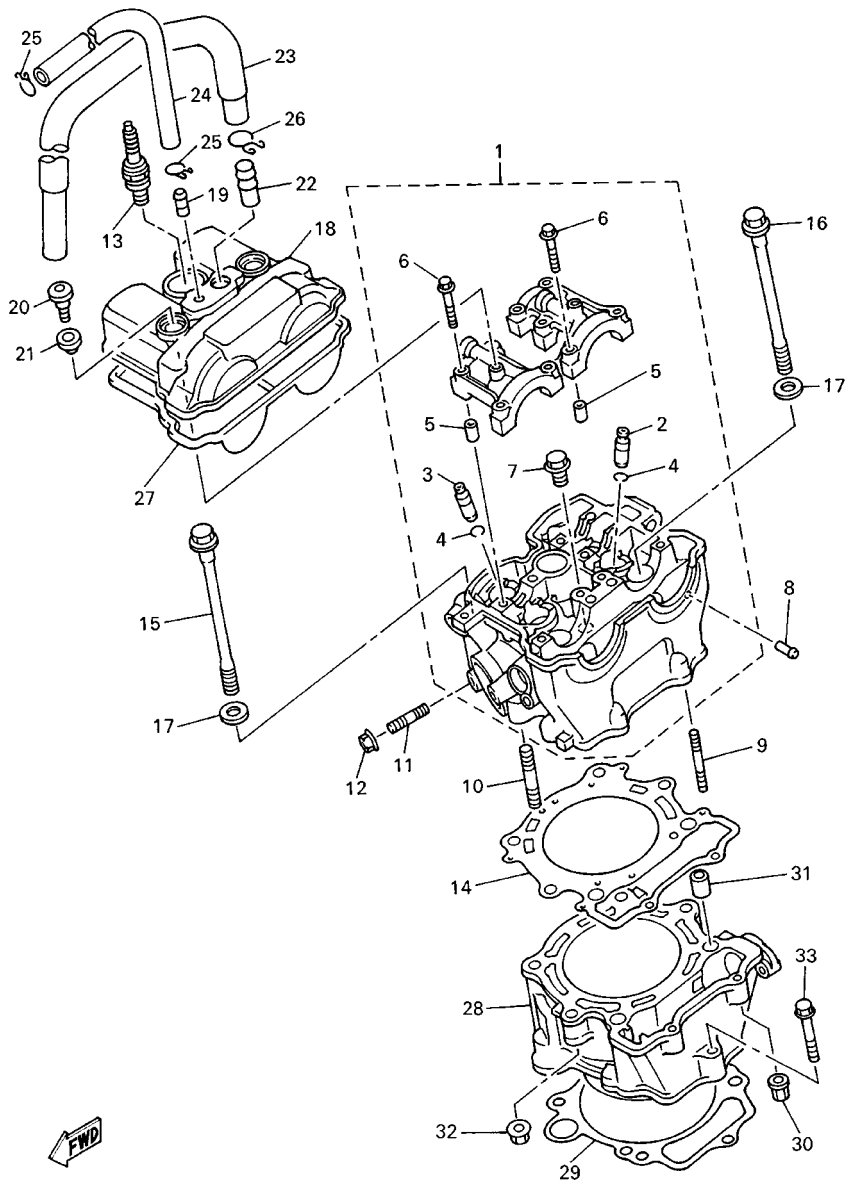
Colouring type code	Colour code	Colour Name	Abbreviation
A	0583	DEEP PURPLISH BLUE SOLID E	DPBSE



5BE100-8010

FIG. 1 CYLINDER

REF. NO.	PART NO.	DESCRIPTION	USA	CAN	OCE	EUR	JPN	REMARKS
1	5BE-11102-10	CYLINDER HEAD ASSY	1	1	1	1	1	
2	5BE-11133-10	.GUIDE, INTAKE VALVE	3	3	3	3	3	
3	5BE-11134-10	.GUIDE, EXHAUST VALVE	2	2	2	2	2	
4	93440-10153	.CIRCLIP	5	5	5	5	5	
5	91808-16023	.PIN, DOWEL	4	4	4	4	4	
6	90105-067A6	.BOLT, WASHER BASED	10	10	10	10	10	
7	90340-12112	.PLUG, STRAIGHT SCREW	1	1	1	1	1	
8	5BE-13582-00	PIPE	1	1	1	1	1	
9	95617-06635	BOLT, STUD	2	2	2	2	2	
10	95617-08635	BOLT, STUD	2	2	2	2	2	
11	95617-08620	BOLT, STUD	1	1	1	1	1	
12	95707-08500	NUT, FLANGE	1	1	1	1	1	
13	94701-00330	PLUG, SPARK (NGK-R CR8E)	1	1	1	1		UR
	94703-00330	PLUG, SPARK (NGK-R CR8E)					1	UR
	94701-00329	PLUG, SPARK (U24ESR-N)	1	1	1	1		UR
	94703-00329	PLUG, SPARK (U24ESR-N)					1	UR
14	5GR-11181-00	GASKET, CYLINDER HEAD 1	1	1	1	1	1	
15	90105-104A7	BOLT, WASHER BASED	2	2	2	2	2	
16	90105-106A3	BOLT, WASHER BASED	2	2	2	2	2	
17	90201-101A4	WASHER, PLATE	4	4	4	4	4	
18	5BE-11191-00	COVER, CYLINDER HEAD 1	1	1	1	1	1	
19	5BE-11167-00	PIPE, BREATHER 2	1	1	1	1	1	
20	90109-066F0	BOLT	2	2	2	2	2	
21	4KG-1111G-00	RUBBER, MOUNT 1	2	2	2	2	2	
22	371-11167-01	PIPE, BREATHER 2	1	1	1	1	1	
23	5BE-11166-00	PIPE, BREATHER 1	1	1	1	1	1	
24	90445-112K0	HOSE	1	1	1	1	1	

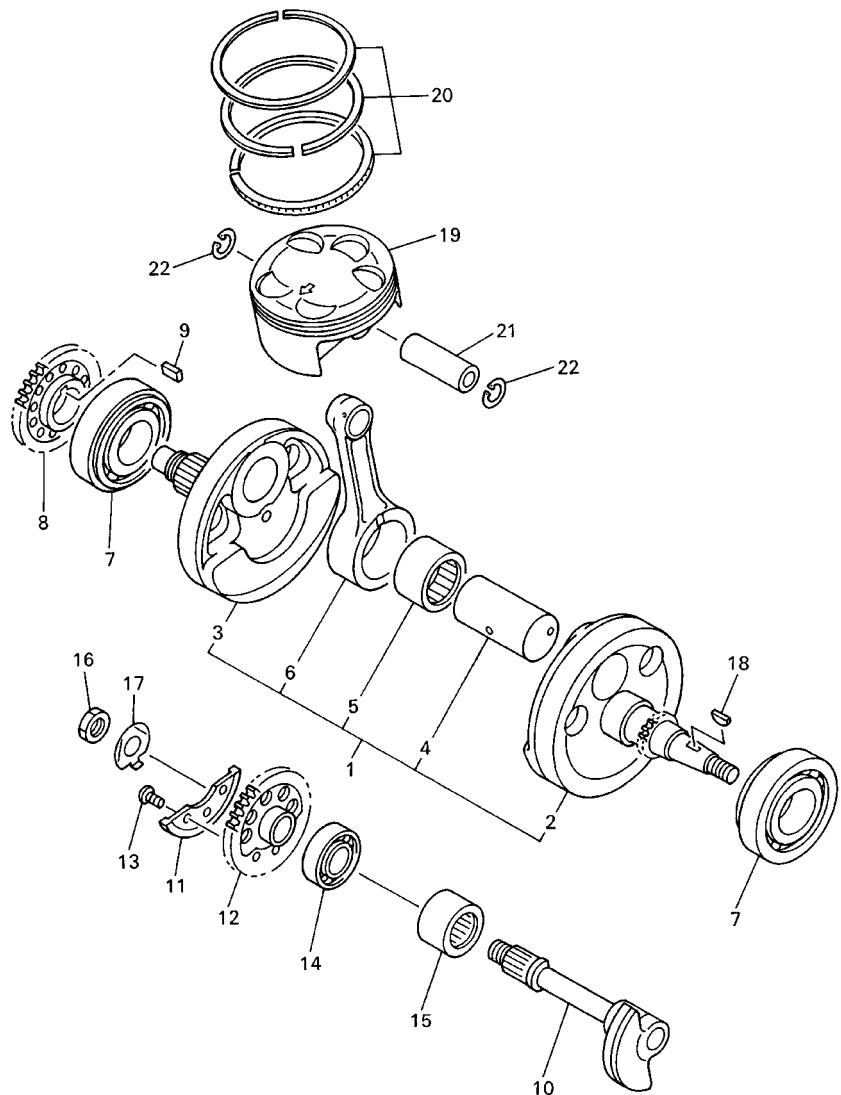


5BE100-8010

FIG. 1 CYLINDER

REF. NO.	PART NO.	DESCRIPTION	USA	CAN	OCE	EUR	JPN	REMARKS
25	90467-11106	CLIP	2	2	2	2	2	
26	90467-14015	CLIP	1	1	1	1	1	
27	5BE-11193-00	GASKET, HEAD COVER 1	1	1	1	1	1	
28	5BE-11311-10	CYLINDER 1	1	1	1	1	1	
29	5BF-11351-00	GASKET, CYLINDER	1	1	1	1	1	
30	90179-06500	NUT	2	2	2	2	2	
31	93612-16254	PIN, DOWEL	2	2	2	2	2	
32	90179-08270	NUT	2	2	2	2	2	
33	95027-06040	BOLT, FLANGE	1	1	1	1	1	

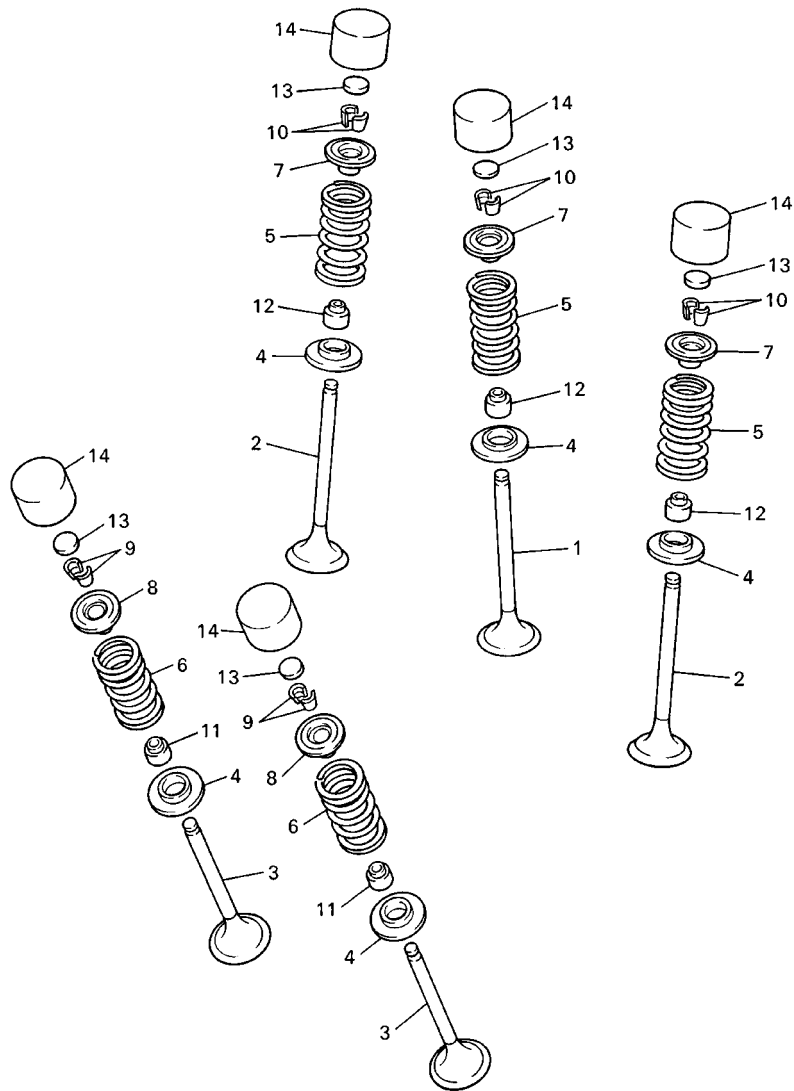
FIG. 2 CRANKSHAFT. PISTON



**FWD**  
5BE100-8020

REF. NO.	PART NO.	DESCRIPTION	USA	CAN	OCE	EUR	JPN	REMARKS
1	5GR-11400-00	CRANKSHAFT ASSY	1	1	1	1	1	
2	5GR-11412-00	.CRANK 1	1	1	1	1	1	
3	5GR-11422-00	.CRANK 2	1	1	1	1	1	
4	5BE-11681-00	.PIN, CRANK 1	1	1	1	1	1	
5	93310-6340H	.BEARING	1	1	1	1	1	
6	5BE-11651-00	.ROD, CONNECTING	1	1	1	1	1	
7	93306-30633	BEARING	2	2	2	2	2	
8	5BE-11536-00	GEAR, DRIVE	1	1	1	1	1	
9	90282-05034	KEY, STRAIGHT	1	1	1	1	1	
10	5BE-11455-00	SHAFT 1	1	1	1	1	1	
11	5BE-11454-00	WEIGHT 1	1	1	1	1	1	
12	5BE-11531-00	GEAR, BALANCE WT	1	1	1	1	1	
13	90149-06250	SCREW	3	3	3	3	3	
14	93306-20335	BEARING	1	1	1	1	1	
15	93311-62574	BEARING	1	1	1	1	1	
16	90170-14171	NUT	1	1	1	1	1	
17	90215-14204	WASHER, LOCK	1	1	1	1	1	
18	90280-03045	KEY, WOODRUFF	1	1	1	1	1	
19	5GR-11631-00	PISTON (STD)	1	1	1	1	1	
20	5BE-11603-00	PISTON RING SET (STD)	1	1	1	1	1	
21	5GR-11633-00	PIN, PISTON	1	1	1	1	1	
22	93420-18082	CIRCLIP	2	2	2	2	2	

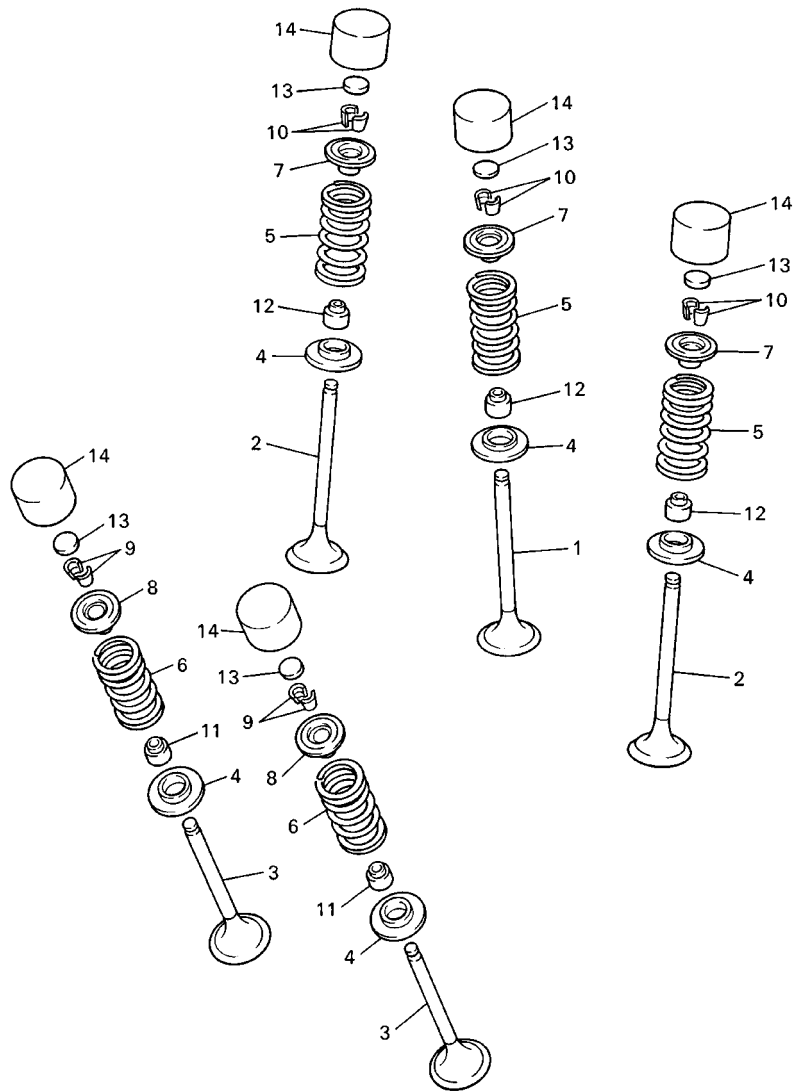
FIG. 3 VALVE



5BE100-8030

REF. NO.	PART NO.	DESCRIPTION	USA	CAN	OCE	EUR	JPN	REMARKS
1	5BE-12111-00	VALVE, INTAKE	1	1	1	1	1	
2	5BE-12112-00	VALVE, INTAKE 2	2	2	2	2	2	
3	5BE-12121-00	VALVE, EXHAUST	2	2	2	2	2	
4	3GM-12126-00	SEAT, VALVE SPRING 2	5	5	5	5	5	
5	5BE-12113-00	SPRING, VALVE INNER	3	3	3	3	3	
6	5GR-12114-00	SPRING, VALVE OUTER	2	2	2	2	2	
7	5BE-12117-00	RETAINER, VALVE SPRING	3	3	3	3	3	
8	4GY-12117-00	RETAINER, VALVE SPRING	2	2	2	2	2	
9	1AA-12118-00	COTTER, VALVE	4	4	4	4	4	
10	1WG-12118-00	COTTER, VALVE	6	6	6	6	6	
11	33M-12119-00	SEAL, VALVE STEM	2	2	2	2	2	
12	4SV-12119-00	SEAL, VALVE STEM	3	3	3	3	3	
13	3LD-12168-00	PAD, ADJUSTING (1.20)	5	5	5	5	5	UR
	3LD-12168-20	PAD, ADJUSTING (1.25)	5	5	5	5	5	UR
	3LD-12168-40	PAD, ADJUSTING (1.30)	5	5	5	5	5	UR
	3LD-12168-60	PAD, ADJUSTING (1.35)	5	5	5	5	5	UR
	3LD-12168-80	PAD, ADJUSTING (1.40)	5	5	5	5	5	UR
	3LD-12168-A0	PAD, ADJUSTING (1.45)	5	5	5	5	5	UR
	3LD-12168-F0	PAD, ADJUSTING (1.50)	5	5	5	5	5	UR
	3LD-12168-H1	PAD, ADJUSTING (1.55)	5	5	5	5	5	UR
	3LD-12168-K1	PAD, ADJUSTING (1.60)	5	5	5	5	5	UR
	3LD-12168-M1	PAD, ADJUSTING (1.65)	5	5	5	5	5	UR
	3LD-12168-R1	PAD, ADJUSTING (1.70)	5	5	5	5	5	UR
	3LD-12168-U1	PAD, ADJUSTING (1.75)	5	5	5	5	5	UR
	3LD-12168-W1	PAD, ADJUSTING (1.80)	5	5	5	5	5	UR
	3LD-12168-Y1	PAD, ADJUSTING (1.85)	5	5	5	5	5	UR
	3LD-12169-11	PAD, ADJUSTING (1.90)	5	5	5	5	5	UR



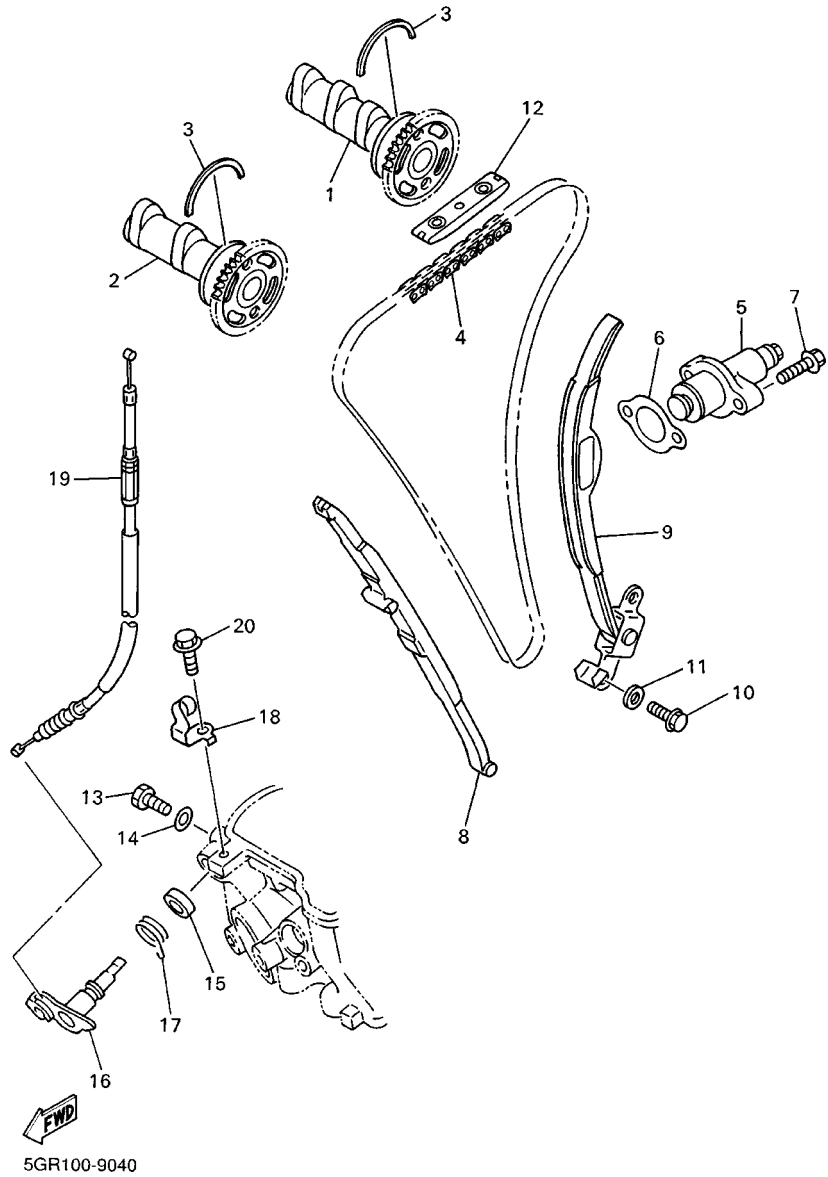


5BE100-8030

FIG. 3 VALVE

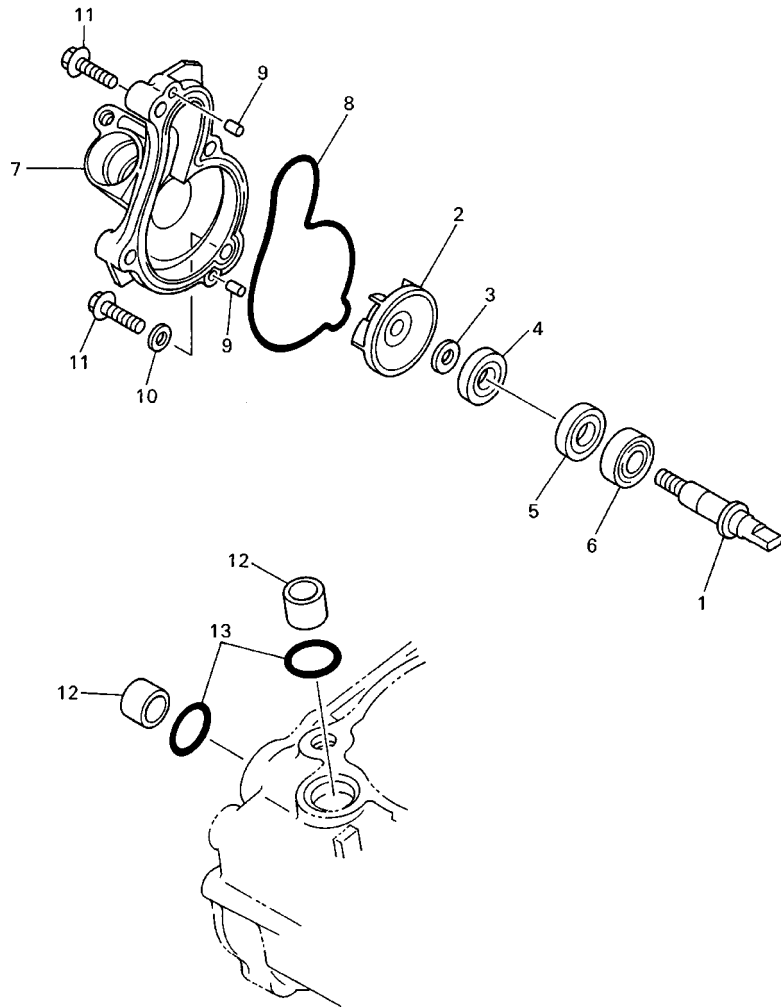
REF. NO.	PART NO.	DESCRIPTION	USA	CAN	OCE	EUR	JPN	REMARKS
13	3LD-12169-31	PAD, ADJUSTING (1.95)	5	5	5	5	5	UR
	3LD-12169-50	PAD, ADJUSTING (2.00)	5	5	5	5	5	UR
	3LD-12169-70	PAD, ADJUSTING (2.05)	5	5	5	5	5	UR
	3LD-12169-90	PAD, ADJUSTING (2.10)	5	5	5	5	5	UR
	3LD-12169-E0	PAD, ADJUSTING (2.15)	5	5	5	5	5	UR
	3LD-12169-G0	PAD, ADJUSTING (2.20)	5	5	5	5	5	UR
	3LD-12169-J0	PAD, ADJUSTING (2.25)	5	5	5	5	5	UR
	3LD-12169-L0	PAD, ADJUSTING (2.30)	5	5	5	5	5	UR
	3LD-12169-N0	PAD, ADJUSTING (2.35)	5	5	5	5	5	UR
	3LD-12169-T0	PAD, ADJUSTING (2.40)	5	5	5	5	5	UR
14	3FV-12153-00	LIFTER, VALVE	5	5	5	5	5	UR BLACK
	3FV-12153-10	LIFTER, VALVE	5	5	5	5	5	UR YELLOW
	3FV-12153-20	LIFTER, VALVE	5	5	5	5	5	UR BLUE

FIG. 4 CAMSHAFT. CHAIN



REF. NO.	PART NO.	DESCRIPTION	USA	CAN	OCE	EUR	JPN	REMARKS
1	5BF-12170-00	CAMSHAFT ASSY 1	1	1	1	1	1	
2	5BF-12180-00	CAMSHAFT ASSY 2	1	1	1	1	1	
3	93440-41178	CIRCLIP	2	2	2	2	2	
4	94591-50120	CHAIN	1	1	1	1	1	
5	5BE-12210-00	TENSIONER ASSY, CAM CHAIN	1	1	1	1	1	
6	4FM-12213-00	GASKET, TENSIONER CASE	1	1	1	1	1	
7	95027-06025	BOLT, FLANGE	2	2	2	2	2	
8	5BE-12251-00	DAMPER, CHAIN 1	1	1	1	1	1	
9	5BE-12252-00	DAMPER, CHAIN 2	1	1	1	1	1	
10	97027-06016	BOLT	2	2	2	2	2	
11	92907-06600	WASHER, PLATE	2	2	2	2	2	
12	5BE-12241-00	GUIDE, STOPPER 2	1	1	1	1	1	
13	90109-06418	BOLT	1	1	1	1	1	
14	90430-06014	GASKET	1	1	1	1	1	
15	93102-12224	OIL SEAL	1	1	1	1	1	
16	5BE-12280-10	DECOMPRESSION ASSY	1	1	1	1	1	
17	90508-162B2	SPRING, TORSION	1	1	1	1	1	
18	5BE-12283-00	BRACKET, DECOMPRESSION	1	1	1	1	1	
19	5BE-12292-00	CABLE, DECOMPRESSION	1	1	1	1	1	
20	95827-06014	BOLT, FLANGE	1	1	1	1	1	

FIG. 5 WATER PUMP

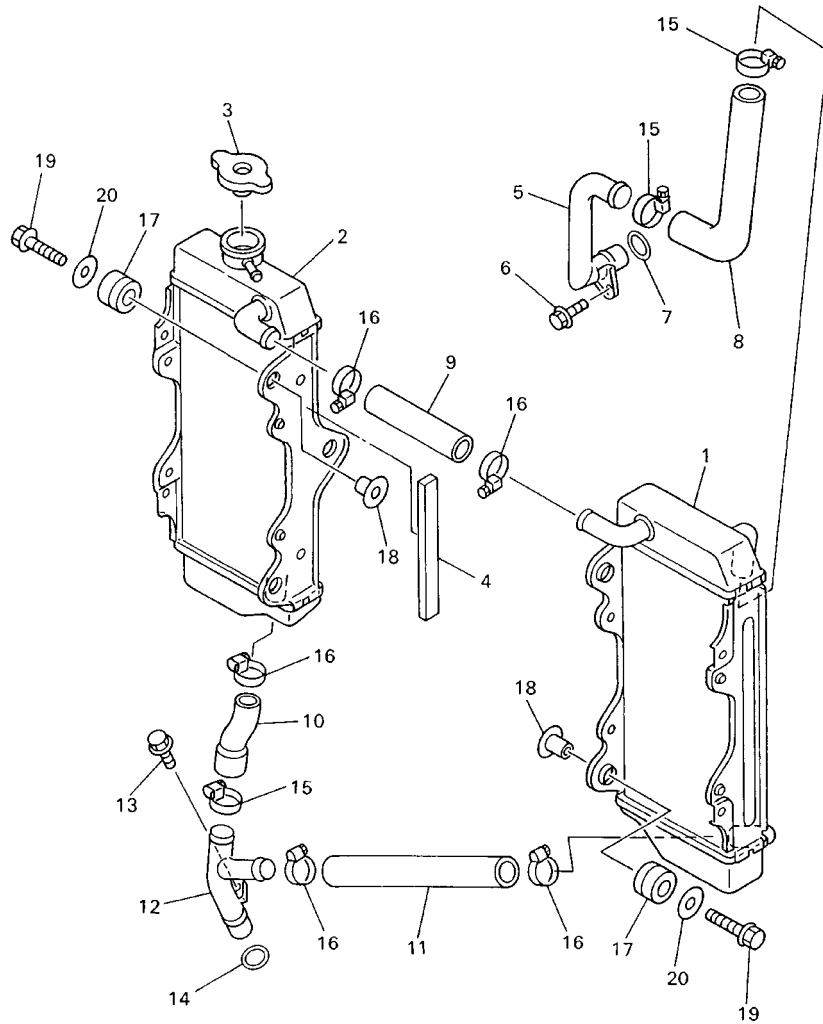


REF. NO.	PART NO.	DESCRIPTION	USA	CAN	OCE	EUR	JPN	REMARKS
1	5GR-12458-00	SHAFT, IMPELLER	1	1	1	1	1	
2	5DJ-12451-00	IMPELLER, WATER PUMP	1	1	1	1	1	
3	90201-08512	WASHER, PLATE	1	1	1	1	1	
4	93109-11073	OIL SEAL	1	1	1	1	1	
5	93102-12106	OIL SEAL (SD 12-22-5 HS)	1	1	1	1	1	
6	93306-00105	BEARING (B6001)	1	1	1	1	1	
7	5BE-12422-10	COVER, HOUSING	1	1	1	1	1	
8	5BE-12439-00	O-RING	1	1	1	1	1	
9	93604-10011	PIN, DOWEL	2	2	2	2	2	
10	90430-06014	GASKET	1	1	1	1	1	
11	95027-06025	BOLT, FLANGE	4	4	4	4	4	
12	5BE-12564-00	PIPE, WATER	2	2	2	2	2	
13	93210-19758	O-RING	2	2	2	2	2	



5BE100-8050

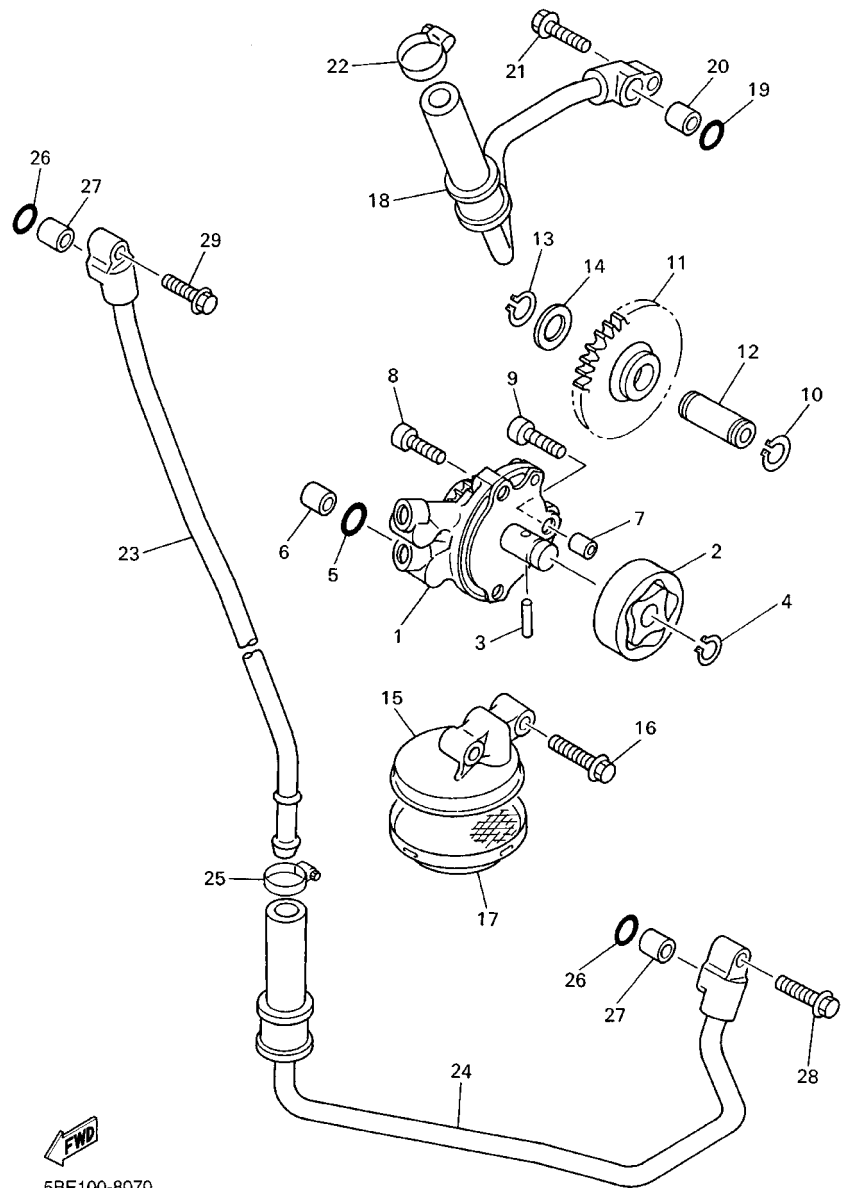
FIG. 6 RADIATOR. HOSE



5BF100-8060

REF. NO.	PART NO.	DESCRIPTION	USA	CAN	OCE	EUR	JPN	REMARKS
1	5BF-1240A-00	RADIATOR ASSY	1	1	1	1	1	
2	5BF-12461-00	RADIATOR ASSY	1	1	1	1	1	
3	22W-12462-00	CAP, RADIATOR	1	1	1	1	1	
4	3GD-24181-00	DAMPER, LOCATING 1	1	1	1	1	1	
5	5BE-12481-00	PIPE 1	1	1	1	1	1	
6	95027-06012	BOLT, FLANGE	1	1	1	1	1	
7	93210-16500	O-RING	1	1	1	1	1	
8	5BE-12576-00	HOSE 1	1	1	1	1	1	
9	5BE-12577-00	HOSE 2	1	1	1	1	1	
10	5BE-12578-00	HOSE 3	1	1	1	1	1	
11	5BE-12579-00	HOSE 4	1	1	1	1	1	
12	5BE-12482-00	PIPE 2	1	1	1	1	1	
13	95027-06012	BOLT, FLANGE	1	1	1	1	1	
14	93210-16500	O-RING	1	1	1	1	1	
15	90450-28014	HOSE CLAMP ASSY	3	3	3	3	3	
16	90450-25037	HOSE CLAMP ASSY	5	5	5	5	5	
17	90480-15528	GROMMET	6	6	6	6	6	
18	90387-0614M	COLLAR	6	6	6	6	6	
19	95027-06025	BOLT, FLANGE	6	6	6	6	6	
20	90201-06071	WASHER, PLATE	6	6	6	6	6	

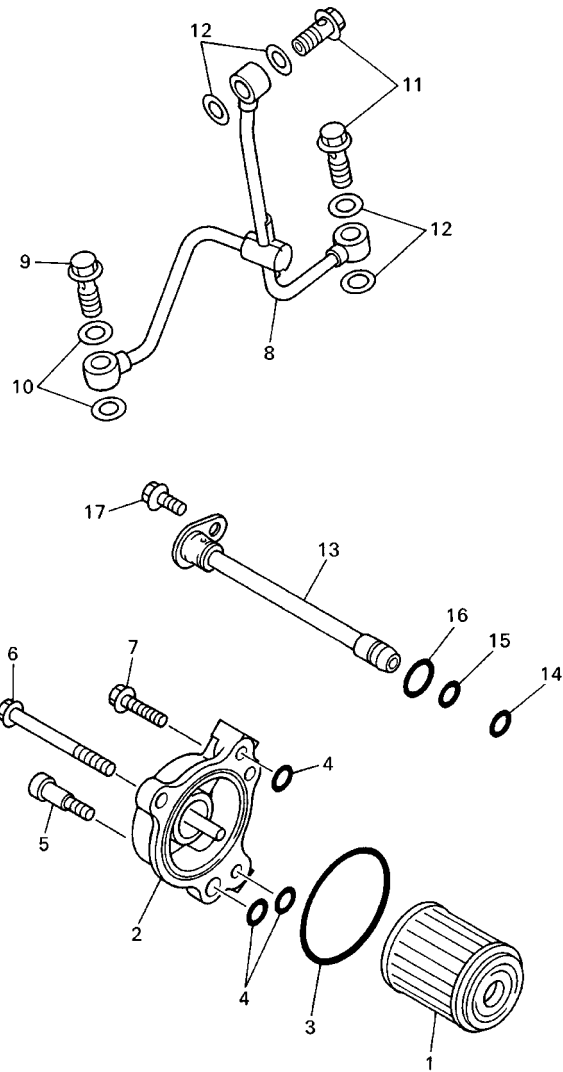
FIG. 7 OIL PUMP



**FWD**  
5BE100-8070

REF. NO.	PART NO.	DESCRIPTION	USA	CAN	OCE	EUR	JPN	REMARKS
1	5BE-13300-00	OIL PUMP ASSY	1	1	1	1	1	
2	1HX-13310-00	ROTOR ASSY 1	1	1	1	1	1	
3	93603-17070	PIN, DOWEL	1	1	1	1	1	
4	93440-10085	CIRCLIP	1	1	1	1	1	
5	93210-10197	O-RING	1	1	1	1	1	
6	99530-10114	PIN, DOWEL	1	1	1	1	1	
7	99530-08012	PIN, DOWEL	1	1	1	1	1	
8	91317-06025	BOLT	2	2	2	2	2	
9	91314-06030	BOLT	1	1	1	1	1	
10	99001-08600	CIRCLIP	1	1	1	1	1	
11	5BE-13341-00	GEAR, OIL PUMP IDLE	1	1	1	1	1	
12	5BE-13342-00	SHAFT, IDLE GEAR	1	1	1	1	1	
13	99009-12400	CIRCLIP	1	1	1	1	1	
14	90201-12166	WASHER, PLATE	1	1	1	1	1	
15	5BE-13412-00	HOUSING, STRAINER	1	1	1	1	1	
16	95027-06025	BOLT, FLANGE	2	2	2	2	2	
17	5BE-13411-00	STRAINER, OIL	1	1	1	1	1	
18	5BE-13464-00	HOSE, OIL 1	1	1	1	1	1	
19	93210-10197	O-RING	1	1	1	1	1	
20	99530-10114	PIN, DOWEL	1	1	1	1	1	
21	95027-06025	BOLT, FLANGE	1	1	1	1	1	
22	90450-22017	HOSE CLAMP ASSY	1	1	1	1	1	
23	5BE-13416-00	PIPE, OIL 1	1	1	1	1	1	
24	5BE-13465-00	HOSE, OIL 2	1	1	1	1	1	
25	90450-22017	HOSE CLAMP ASSY	1	1	1	1	1	
26	93210-10197	O-RING	2	2	2	2	2	
27	99530-10114	PIN, DOWEL	2	2	2	2	2	

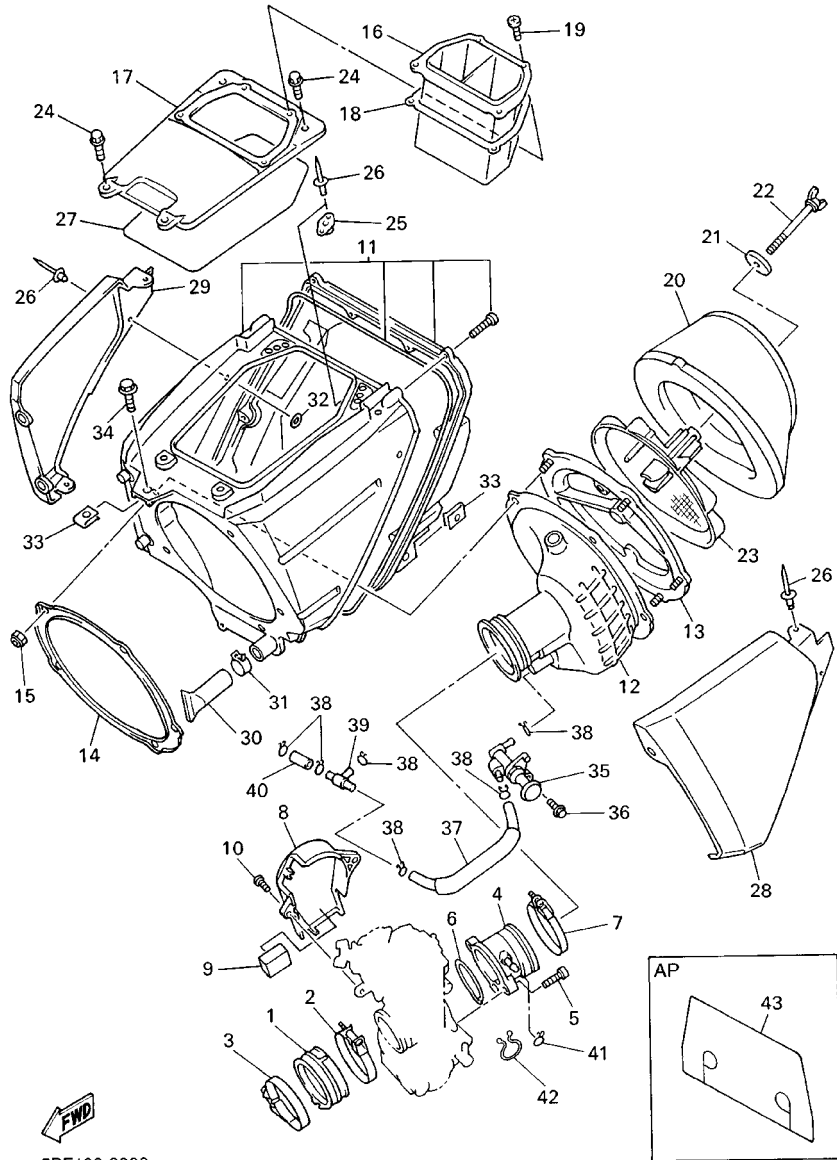




  
5BE100-8080

FIG. 8 OIL CLEANER

REF. NO.	PART NO.	DESCRIPTION	USA	CAN	OCE	EUR	JPN	REMARKS
1	1UY-13440-02	ELEMENT ASSY, OIL CLEANER	1	1	1	1	1	
2	5BE-13447-00	COVER, OIL ELEMENT	1	1	1	1	1	
3	93210-50553	O-RING	1	1	1	1	1	
4	93210-07135	O-RING	3	3	3	3	3	
5	90109-065G2	BOLT	1	1	1	1	1	
6	95027-06065	BOLT, FLANGE	1	1	1	1	1	
7	95027-06020	BOLT, FLANGE	1	1	1	1	1	
8	5BE-13161-01	PIPE, DELIVERY 1	1	1	1	1	1	
9	90401-10159	BOLT, UNION	1	1	1	1	1	
10	90430-10188	GASKET	2	2	2	2	2	
11	90401-08038	BOLT, UNION	2	2	2	2	2	
12	90430-08119	GASKET	4	4	4	4	4	
13	5BE-13171-00	PIPE, DELIVERY 2	1	1	1	1	1	
14	93210-07003	O-RING	1	1	1	1	1	
15	93210-09008	O-RING	1	1	1	1	1	
16	93210-12759	O-RING	1	1	1	1	1	
17	95027-06012	BOLT, FLANGE	1	1	1	1	1	

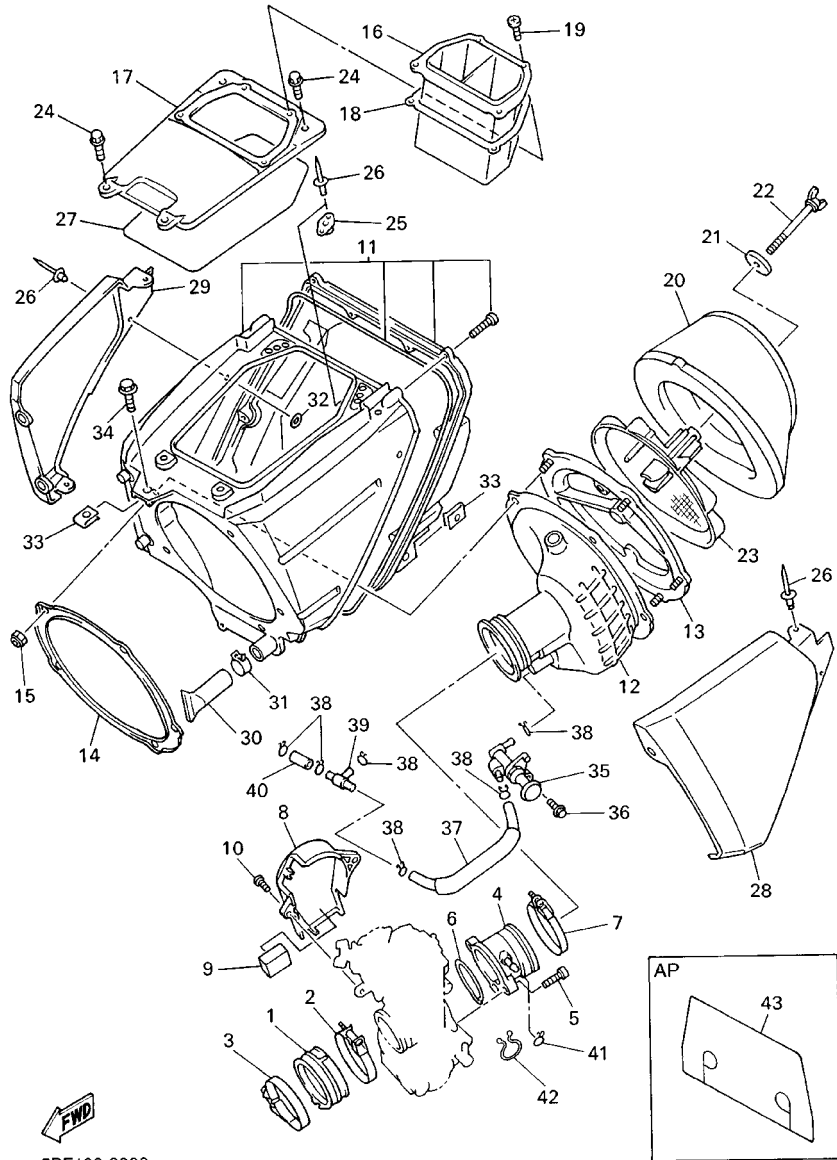


5BF100-8090

FIG. 9 INTAKE

REF. NO.	PART NO.	DESCRIPTION	USA	CAN	OCE	EUR	JPN	REMARKS
1	5BE-13597-01	JOINT, CARBURETOR 3	1	1	1	1	1	
2	90450-57092	HOSE CLAMP ASSY	1	1	1	1	1	
3	90450-59091	HOSE CLAMP ASSY	1	1	1	1	1	
4	5BF-1440F-00	JOINT, AIR FILTER 1	1	1	1	1	1	
5	91317-05014	BOLT	2	2	2	2	2	
6	4FN-14561-00	O-RING	1	1	1	1	1	
7	90460-61162	CLAMP, HOSE	1	1	1	1	1	
8	5BE-14293-00	COVER 1	1	1	1	1	1	
9	5BF-14409-00	DAMPER	1	1	1	1	1	
10	90111-06017	BOLT	2	2	2	2	2	
11	5BE-14401-00	AIR CLEANER CASE ASSY	1	1	1	1	1	
12	5BE-14453-00	JOINT, AIR CLEANER 1	1	1	1	1	1	
13	3JD-14459-01	HOLDER, GUIDE	1	1	1	1	1	
14	3JD-14477-00	PLATE	1	1	1	1	1	
15	95607-05100	NUT, U	5	5	5	5	5	
16	5BF-14437-00	DUCT	1	1	1	1	1	
17	5BF-1441A-00	COVER, CLEANER CASE 1	1	1	1	1	1	
18	5BF-14452-00	SEAL	1	1	1	1	1	
19	97707-50012	SCREW, TAPPING	4	4	4	4	4	
20	4XM-14451-00	ELEMENT, AIR CLEANER	1	1	1	1	1	
21	90209-06096	WASHER	1	1	1	1	1	
22	90122-06035	BOLT, WING	1	1	1	1	1	
23	5BE-14458-00	GUIDE	1	1	1	1	1	
24	90146-06014	SCREW, OVAL FILLISTER	4	4	4	4	4	
25	5BF-14493-00	STAY 1	2	2	2	2	2	
26	90267-32070	RIVET, BLIND	9	9	9	9	9	
27	5BF-14457-00	SEAL	1	1	1	1	1	

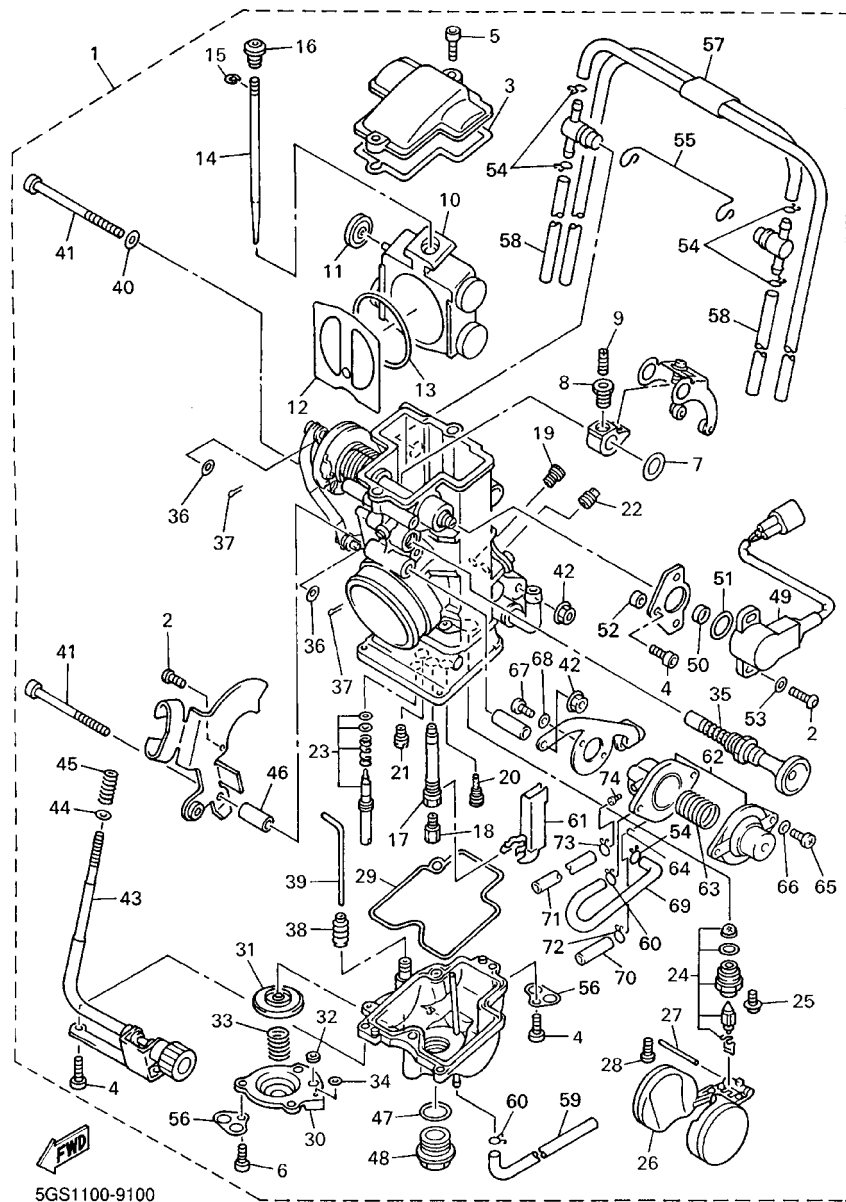




5BF100-8090

FIG. 9 INTAKE

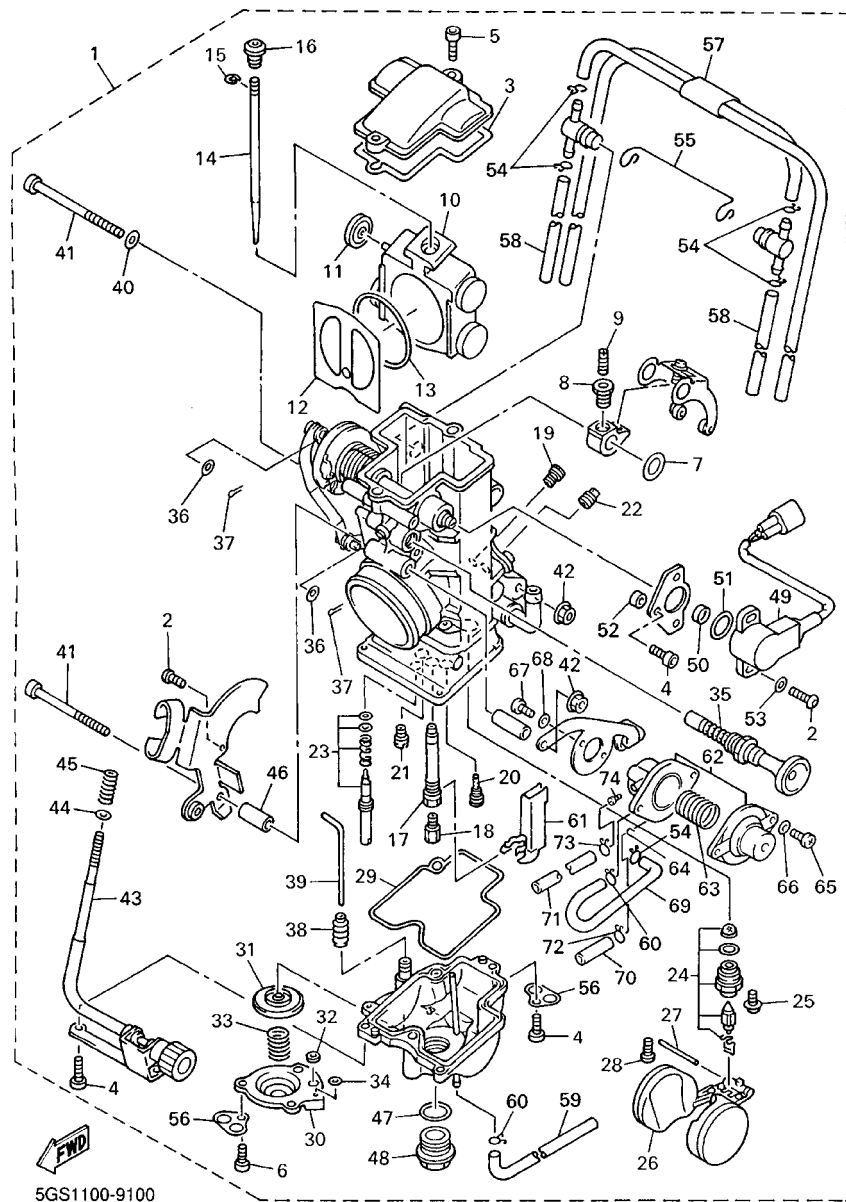
REF. NO.	PART NO.	DESCRIPTION	USA	CAN	OCE	EUR	JPN	REMARKS
28	5BE-1441A-00	COVER, CLEANER CASE 1	1	1	1	1	1	
29	5BE-1441E-00	COVER, CLEANER CASE 2	1	1	1	1	1	
30	5BF-1443E-00	PIPE, DRAIN	1	1	1	1	1	
31	90467-17089	CLIP	1	1	1	1	1	
32	90201-03313	WASHER, PLATE	5	5	5	5	5	
33	90183-06023	NUT, SPRING	2	2	2	2	2	
34	95027-06012	BOLT, FLANGE	1	1	1	1	1	
35	5GR-14340-00	VALVE ASSY	1	1	1	1	1	
36	95027-06016	BOLT, FLANGE	1	1	1	1	1	
37	5BF-14349-00	PIPE	1	1	1	1	1	
38	90467-09103	CLIP	6	6	6	6	6	
39	90413-06031	WAY 3	1	1	1	1	1	
40	90445-095K0	HOSE	1	1	1	1	1	
41	90467-08017	CLIP	1	1	1	1	1	
42	90464-16039	CLAMP	1	1	1	1	1	
43	5BE-14417-00	COVER 1	1	1	1	1	1	AP



5GS1100-9100

FIG. 10 CARBURETOR

REF. NO.	PART NO.	DESCRIPTION	USA	CAN	OCE	EUR	JPN	REMARKS
1	5GS-14101-00	CARBURETOR ASSY 1	1					
	5GS-14101-10	CARBURETOR ASSY 1		1	1	1	1	
2	3TJ-14496-40	.BOLT	5	5	5	5	5	
3	5BE-14959-00	.GASKET	1	1	1	1	1	
4	91316-04012	.BOLT	4	4	4	4	4	
5	91316-04012	.BOLT	2	2	2	2	2	
6	91316-04008	.BOLT	3	3	3	3	3	
7	90202-08045	.WASHER, PLATE	1	1	1	1	1	
8	3TJ-14393-40	.NUT, CROWN	1	1	1	1	1	
9	3TJ-14522-40	.SCREW, ADJUST	1	1	1	1	1	
10	5BE-14388-00	.VALVE ASSY	1	1	1	1	1	
11	3TJ-14267-40	.ROLLER	1	1	1	1	1	
12	4FN-14546-00	.VALVE, NEEDLE	1	1	1	1	1	
13	4FN-14997-00	.SEAL	1	1	1	1	1	
14	5BF-14916-DM	.NEEDLE (#DTM)	1					STD
	5GS-14916-DM	.NEEDLE (#DXM)		1	1	1	1	STD
	5BF-14916-DJ	.NEEDLE (#DTJ)	1					AP
	5GS-14916-DJ	.NEEDLE (#DXJ)		1	1	1	1	AP
	5BF-14916-DK	.NEEDLE (#DTK)	1					AP
	5GS-14916-DK	.NEEDLE (#DXK)		1	1	1	1	AP
	5BF-14916-DL	.NEEDLE (#DTL)	1					AP
	5GS-14916-DL	.NEEDLE (#DXL)		1	1	1	1	AP
	5BF-14916-DN	.NEEDLE (#DTN)	1					AP
	5GS-14916-DN	.NEEDLE (#DXN)		1	1	1	1	AP
	5BF-14916-DP	.NEEDLE (#DTP)	1					AP
	5GS-14916-DP	.NEEDLE (#DXP)		1	1	1	1	AP
	5BF-14916-D1	.NEEDLE (#DTQ)	1					AP

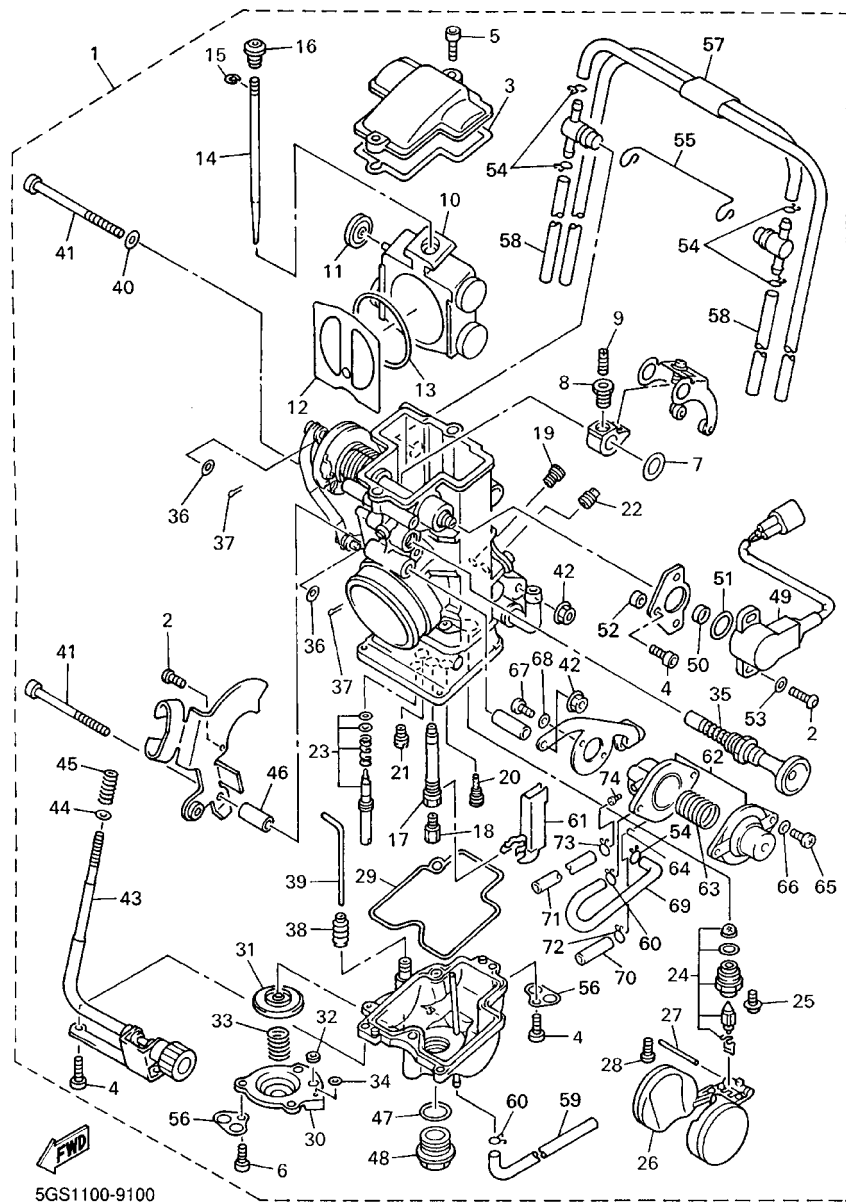


5GS1100-9100

FIG. 10 CARBURETOR

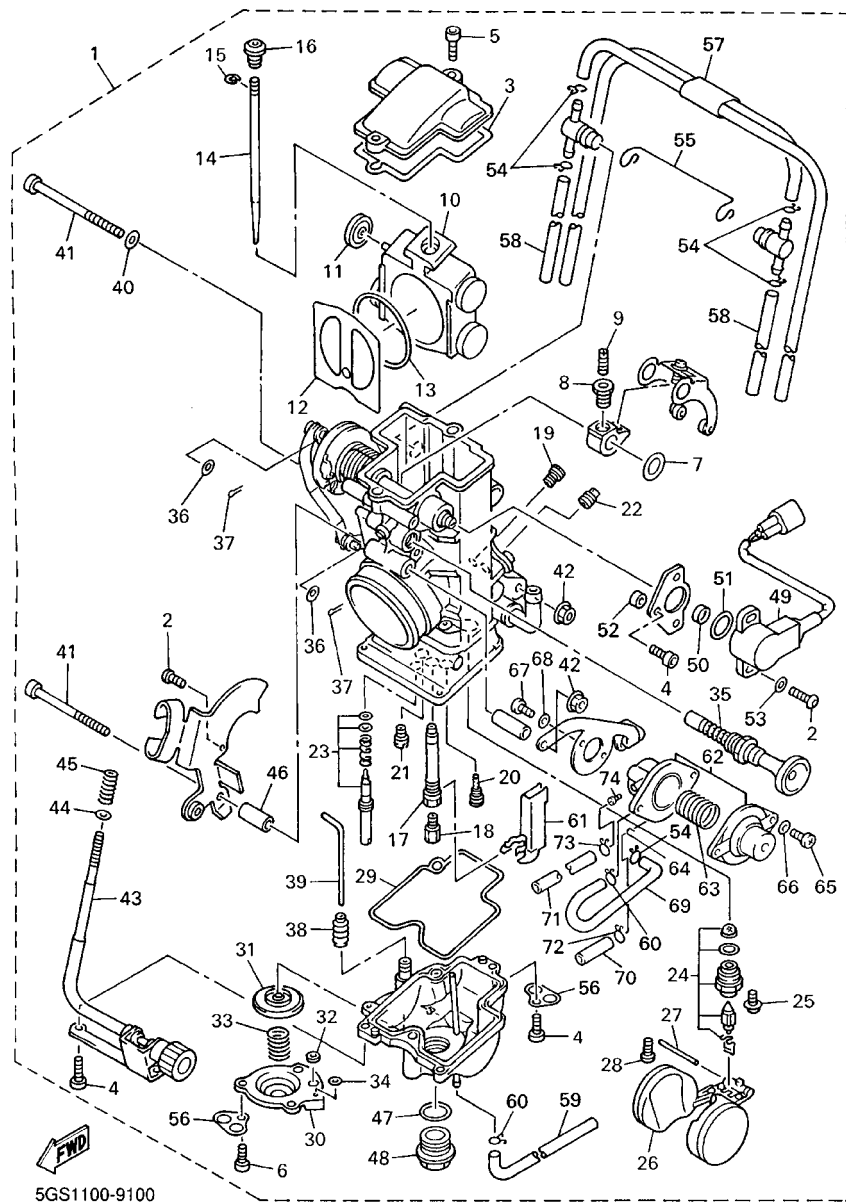
REF. NO.	PART NO.	DESCRIPTION	USA	CAN	OCE	EUR	JPN	REMARKS
14	5GS-14916-D1	.NEEDLE (#DXQ)		1	1	1	1	AP
15	3TJ-14159-40	.CLIP	1	1	1	1	1	
16	5BE-14521-00	.SCREW, ADJUST	1	1	1	1	1	
17	5BE-14947-00	.JET, NEEDLE	1	1	1	1	1	
18	4MX-14943-91	.JET, MAIN (#168)	1	1	1	1	1	STD
	4MX-14943-89	.JET, MAIN (#158)	1	1	1	1	1	AP
	4MX-14943-39	.JET, MAIN (#160)	1	1	1	1	1	AP
	4MX-14943-90	.JET, MAIN (#162)	1	1	1	1	1	AP
	4MX-14943-40	.JET, MAIN (#165)	1	1	1	1	1	AP
	4MX-14943-41	.JET, MAIN (#170)	1	1	1	1	1	AP
	4MX-14943-92	.JET, MAIN (#172)	1	1	1	1	1	AP
	4MX-14943-42	.JET, MAIN (#175)	1	1	1	1	1	AP
	4MX-14943-93	.JET, MAIN (#178)	1	1	1	1	1	AP
	4MX-14943-43	.JET, MAIN (#180)	1	1	1	1	1	AP
19	3TJ-14943-47	.JET (#200)	1	1	1	1	1	
20	3TJ-14948-05	.JET (#45)	1	1	1	1	1	STD
	3TJ-14948-03	.JET (#40)	1	1	1	1	1	AP
	3TJ-14948-04	.JET (#42)	1	1	1	1	1	AP
	3TJ-14948-06	.JET (#48)	1	1	1	1	1	AP
	3TJ-14948-07	.JET (#50)	1	1	1	1	1	AP
21	3TJ-1494F-11	.JET (#60)	1					STD
	3TJ-1494F-12	.JET (#62)		1	1	1	1	STD
	3TJ-1494F-18	.JET (#78)	1	1	1	1	1	AP
	3TJ-1494F-19	.JET (#80)	1	1	1	1	1	AP
	3TJ-1494F-20	.JET (#82)	1	1	1	1	1	AP
	3TJ-1494F-21	.JET (#85)	1	1	1	1	1	AP
	3TJ-1494F-22	.JET (#88)	1	1	1	1	1	AP

FIG. 10 CARBURETOR



5GS1100-9100

REF. NO.	PART NO.	DESCRIPTION	USA	CAN	OCE	EUR	JPN	REMARKS
21	3TJ-1494F-23	.JET (#90)	1	1	1	1	1	AP
22	7A9-14943-17	.JET, MAIN (#75)	1	1	1	1	1	STD
	7A9-14943-11	.JET, MAIN (#60)	1	1	1	1	1	AP
23	3TJ-14105-40	.PILOT SCREW SET	1	1	1	1	1	
24	5BE-14107-00	.NEEDLE VALVE SET	1	1	1	1	1	
25	5BE-14216-00	.SCREW	1	1	1	1	1	
26	5BE-14985-00	.FLOAT	1	1	1	1	1	
27	676-14548-00	.PIN, FLOAT ARM	1	1	1	1	1	
28	688-14592-00	.SCREW	1	1	1	1	1	
29	3TJ-14984-40	.GASKET, FLOAT CHAMBER	1	1	1	1	1	
30	3TJ-14293-40	.COVER 1	1	1	1	1	1	
31	5BE-14940-18	.DIAPHRAGM ASSY	1	1	1	1	1	STD
	5BE-14940-17	.DIAPHRAGM ASSY	1	1	1	1	1	AP
	5BE-14940-19	.DIAPHRAGM ASSY	1	1	1	1	1	AP
32	3TJ-14536-40	.GASKET	1	1	1	1	1	
33	3TJ-14933-40	.SPRING, DIAPHRAGM	1	1	1	1	1	
34	6H4-14561-00	.O-RING	1	1	1	1	1	
35	5BE-14171-00	.PLUNGER, STARTER	1	1	1	1	1	
36	90202-03052	.WASHER, PLATE	2	2	2	2	2	
37	3TJ-14365-40	.PIN, CLEVIS	2	2	2	2	2	
38	5BE-14968-00	.CAP	1	1	1	1	1	
39	5BE-14379-01	.ROD, STARTER	1	1	1	1	1	
40	5BE-14557-00	.WASHER	1	1	1	1	1	
41	5BE-14162-00	.BOLT, HOLDING	2	2	2	2	2	
42	95704-05500	.NUT, FLANGE	2	2	2	2	2	
43	5BE-14922-01	.SCREW, THROTTLE	1	1	1	1	1	
44	90201-08410	.WASHER, PLATE	1	1	1	1	1	



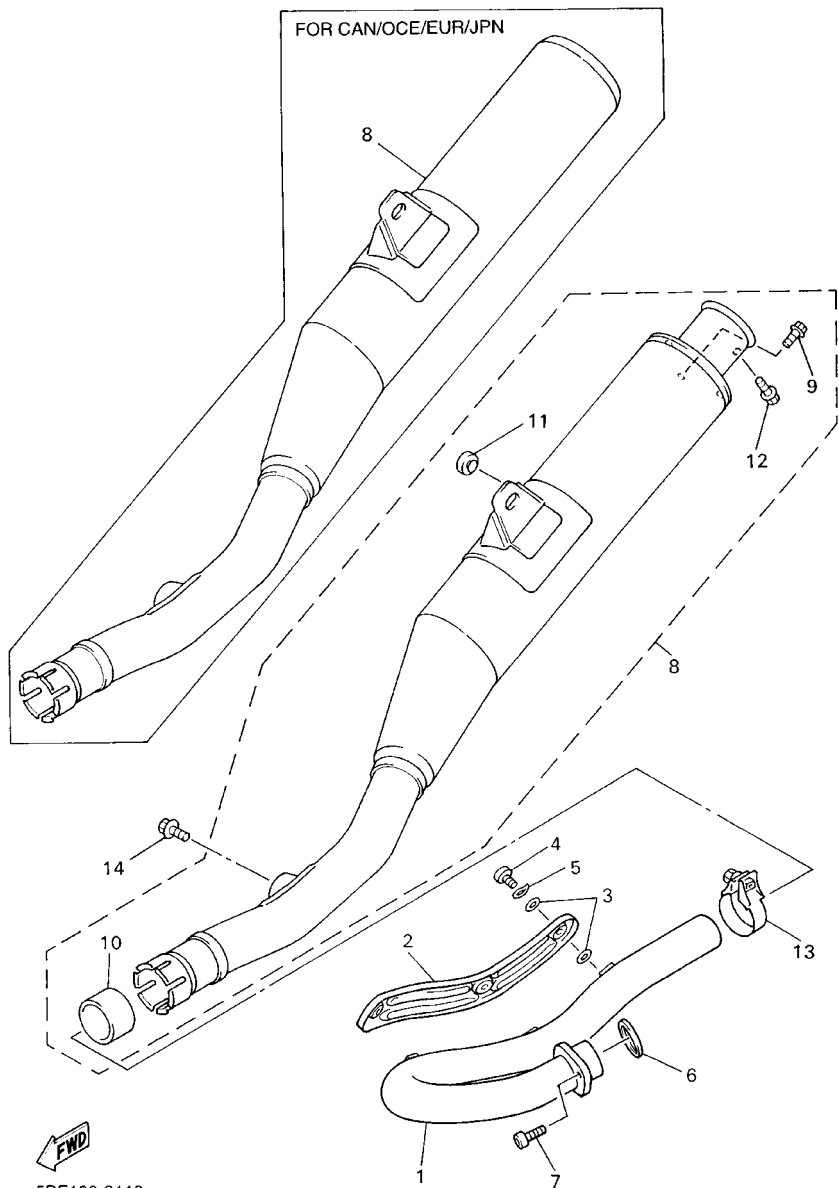
5GS1100-9100

FIG. 10 CARBURETOR

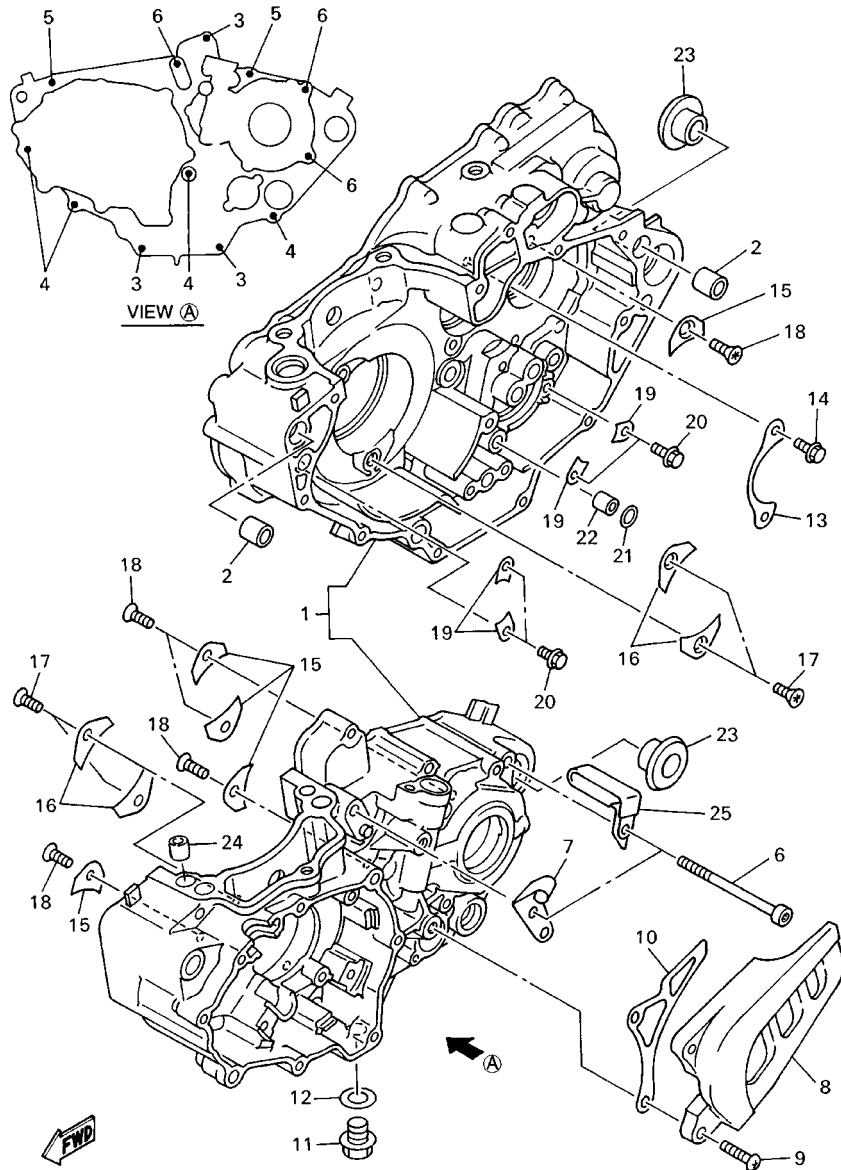
REF. NO.	PART NO.	DESCRIPTION	USA	CAN	OCE	EUR	JPN	REMARKS
45	4FN-14934-00	.SPRING, THROTTLE STOP	1	1	1	1	1	
46	5BE-14535-00	.COLLAR	1	1	1	1	1	
47	5BE-14561-00	.O-RING	1	1	1	1	1	
48	5BE-14115-00	.PLUG, SCREW	1	1	1	1	1	
49	5BE-85885-00	.THROTTLE SENSOR ASSY	1	1	1	1	1	
50	5BE-14449-00	.COLLAR	1	1	1	1	1	
51	5BE-14562-00	.O-RING	1	1	1	1	1	
52	5BE-14265-00	.COLLAR	1	1	1	1	1	
53	5BE-14596-00	.WASHER	2	2	2	2	2	
54	3TJ-14137-40	.CLIP	5	5	5	5	5	
55	5BE-14137-00	.CLIP	1	1	1	1	1	
56	5BE-14146-00	.PLATE	2	2	2	2	2	
57	5BE-14197-00	.PIPE	1	1	1	1	1	
58	5BE-14148-00	.PIPE	2	2	2	2	2	
59	5BE-14987-00	.HOSE	1	1	1	1	1	
60	5BE-14937-00	.CLIP	2	2	2	2	2	
61	5BE-14346-00	.PLATE	1	1	1	1	1	
62	5BF-14940-00	.DIAPHRAGM ASSY	1	1	1	1	1	
63	5BF-14933-00	.SPRING, DIAPHRAGM	1	1	1	1	1	
64	5BF-14854-00	.U-RING	1	1	1	1	1	
65	98502-04010	.SCREW, PAN HEAD	2	2	2	2	2	
66	92902-04100	.WASHER, SPRING	2	2	2	2	2	
67	98502-04008	.SCREW, PAN HEAD	2	2	2	2	2	
68	92902-04100	.WASHER, SPRING	2	2	2	2	2	
69	5BF-14871-00	.PIPE 1	1	1	1	1	1	
70	5BF-14872-00	.PIPE 2	1	1	1	1	1	
71	5BF-14873-00	.PIPE 3	1	1	1	1	1	



FIG. 11 EXHAUST



REF. NO.	PART NO.	DESCRIPTION	USA	CAN	OCE	EUR	JPN	REMARKS
1	5BE-14611-00	PIPE, EXHAUST 1	1	1	1	1	1	
2	5BE-14628-00	PROTECTOR, EXHAUST PIPE	1	1	1	1	1	
3	4BD-14766-00	WASHER, PROTECTOR	6	6	6	6	6	
4	98980-06008	SCREW, BIND	3	3	3	3	3	
5	90206-06090	WASHER, WAVE	3	3	3	3	3	
6	3VD-14613-00	GASKET, EXHAUST PIPE	1	1	1	1	1	
7	91317-08020	BOLT	1	1	1	1	1	
8	5BF-14710-00	MUFFLER ASSY 1	1					
	5BF-14710-10	MUFFLER ASSY 1		1	1	1	1	
9	95804-06010	BOLT, FLANGE	3					
10	3GW-14714-00	GASKET, MUFFLER	1	1	1	1	1	
11	22W-24181-00	DAMPER, LOCATING 1	1	1	1	1	1	
12	95804-06016	BOLT, FLANGE	1					
13	5BE-14788-00	BAND, SILENCER	1	1	1	1	1	
14	95817-08012	BOLT, FLANGE	2	2	2	2	2	



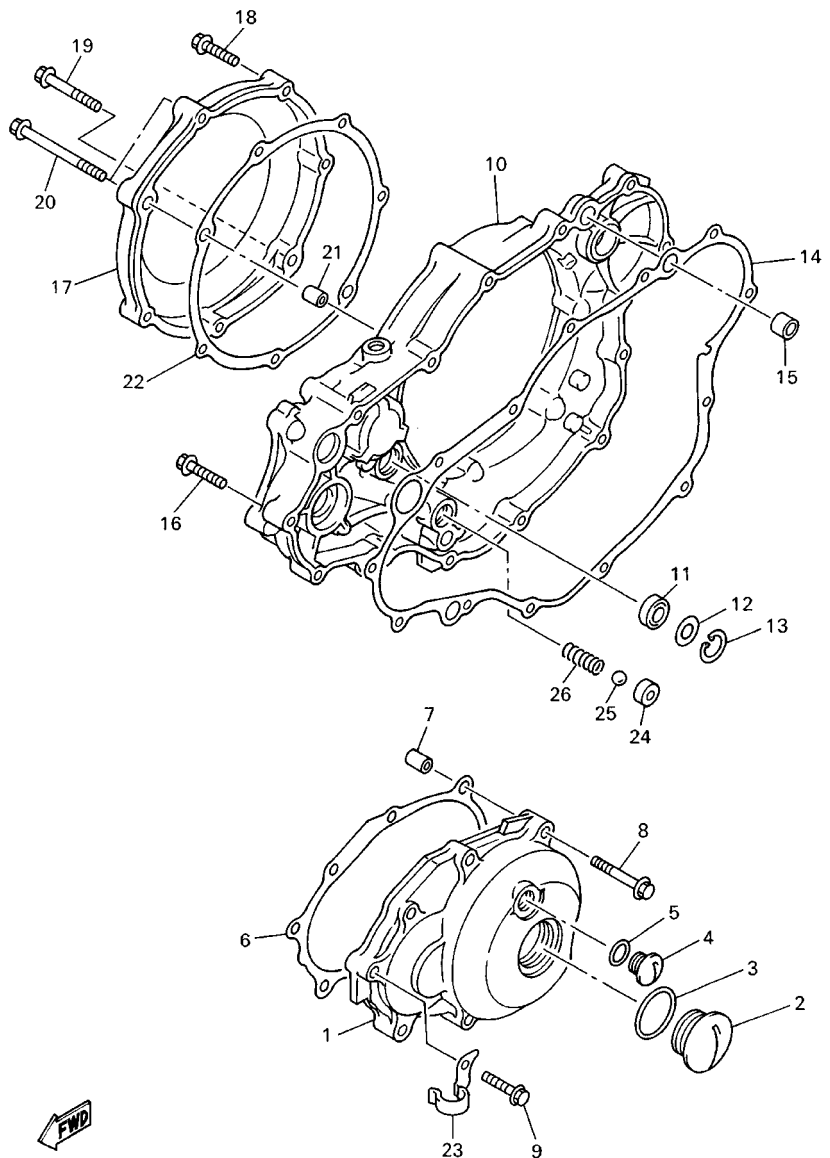
5BE100-8120

FIG. 12 CRANKCASE

REF. NO.	PART NO.	DESCRIPTION	USA	CAN	OCE	EUR	JPN	REMARKS
1	5BE-15150-02	CRANKCASE ASSY	1	1	1	1	1	
2	99530-14016	PIN, DOWEL	2	2	2	2	2	
3	91317-06040	BOLT	3	3	3	3	3	
4	91317-06050	BOLT	4	4	4	4	4	
5	91317-06060	BOLT	2	2	2	2	2	
6	91317-06075	BOLT	3	3	3	3	3	
7	5BE-15441-00	HOLDER, CLUTCH CABLE	1	1	1	1	1	
8	5BE-15421-00	COVER, CRANKCASE 2	1	1	1	1	1	
9	98507-06025	SCREW, PAN HEAD	2	2	2	2	2	
10	5BE-17466-10	GUIDE, CHAIN	1	1	1	1	1	
11	90340-12059	PLUG, STRAIGHT SCREW	1	1	1	1	1	
12	90430-12213	GASKET	1	1	1	1	1	
13	4L0-17471-00	PLATE, COVER	1	1	1	1	1	
14	90105-06553	BOLT, WASHER BASED	2	2	2	2	2	
15	4JT-15381-01	PLATE, BEARING COVER	5	5	5	5	5	
16	5BE-15383-00	PLATE, BEARING COVER	4	4	4	4	4	
17	90149-06286	SCREW	4	4	4	4	4	
18	90149-06326	SCREW	5	5	5	5	5	
19	5DH-18562-00	PLATE, STOPPER 2	4	4	4	4	4	
20	90105-06553	BOLT, WASHER BASED	4	4	4	4	4	
21	93210-10197	O-RING	1	1	1	1	1	
22	99530-10114	PIN, DOWEL	1	1	1	1	1	
23	90387-1712Y	COLLAR	2	2	2	2	2	
24	99530-10116	PIN, DOWEL	2	2	2	2	2	
25	90461-10136	CLAMP	1	1	1	1	1	

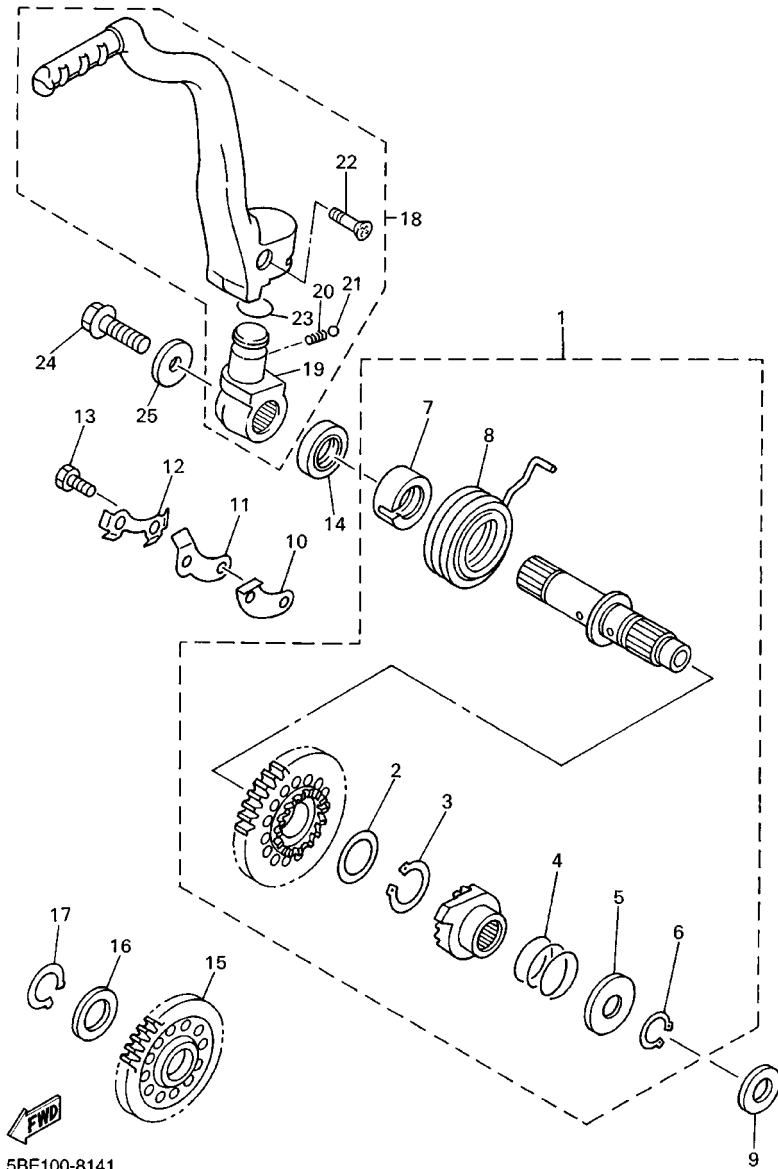


FIG. 13 CRANKCASE COVER 1



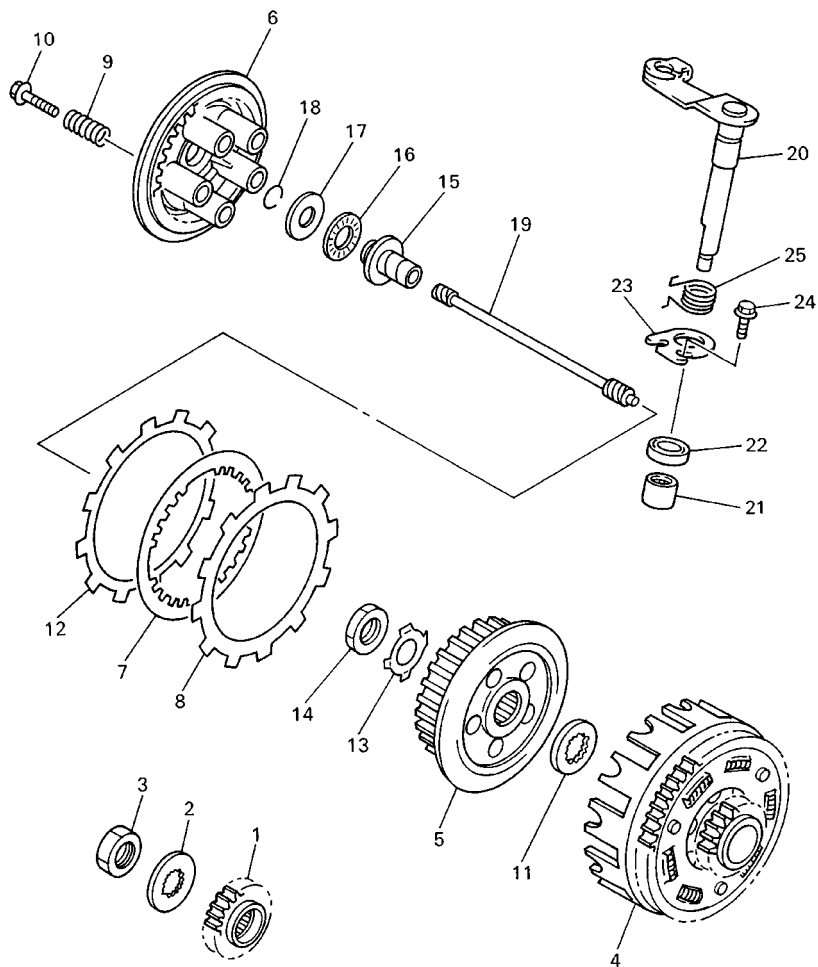
REF. NO.	PART NO.	DESCRIPTION	USA	CAN	OCE	EUR	JPN	REMARKS
1	5BE-15411-00	COVER, CRANKCASE 1	1	1	1	1	1	
2	90340-32123	PLUG, STRAIGHT SCREW	1	1	1	1	1	
3	93210-32172	O-RING	1	1	1	1	1	
4	90340-14128	PLUG, STRAIGHT SCREW	1	1	1	1	1	
5	93210-14369	O-RING	1	1	1	1	1	
6	5BE-15451-00	GASKET, CRANKCASE COVER 1	1	1	1	1	1	
7	99530-08016	PIN, DOWEL	2	2	2	2	2	
8	95027-06040	BOLT, FLANGE	2	2	2	2	2	
9	95027-06030	BOLT, FLANGE	6	6	6	6	6	
10	5BE-15431-00	COVER, CRANKCASE 3	1	1	1	1	1	
11	93101-14164	OIL SEAL	1	1	1	1	1	
12	90201-15701	WASHER, PLATE (1.0T)	1	1	1	1	1	
13	99009-22500	CIRCLIP	1	1	1	1	1	
14	5BE-15462-00	GASKET, CRANKCASE COVER 3	1	1	1	1	1	
15	91812-16001	PIN, DOWEL	2	2	2	2	2	
16	95027-06030	BOLT, FLANGE	10	10	10	10	10	
17	5BE-15415-00	COVER, GENERATOR	1	1	1	1	1	
18	95027-06030	BOLT, FLANGE	4	4	4	4	4	
19	95027-06040	BOLT, FLANGE	1	1	1	1	1	
20	90105-065A1	BOLT, WASHER BASED	2	2	2	2	2	
21	99530-08016	PIN, DOWEL	2	2	2	2	2	
22	5BE-15453-00	GASKET	1	1	1	1	1	
23	90462-10241	CLAMP	1	1	1	1	1	
24	583-13113-00	SEAT, CHECK BALL	1	1	1	1	1	
25	93503-08007	BALL	1	1	1	1	1	
26	90501-043E0	SPRING, COMPRESSION	1	1	1	1	1	

FIG. 14 STARTER



REF. NO.	PART NO.	DESCRIPTION	USA	CAN	OCE	EUR	JPN	REMARKS
1	5GR-15601-00	KICK SHAFT ASSY	1	1	1	1	1	
2	90201-20685	.WASHER, PLATE (0.5T)	1	1	1	1	1	
3	93410-20038	.CIRCLIP	1	1	1	1	1	
4	90501-16107	.SPRING, COMPRESSION	1	1	1	1	1	
5	90201-167P7	.WASHER, PLATE	1	1	1	1	1	
6	99009-16400	.CIRCLIP	1	1	1	1	1	
7	5GR-15664-00	.GUIDE, SPRING	1	1	1	1	1	
8	90508-30743	.SPRING, TORSION	1	1	1	1	1	
9	90201-162H4	WASHER, PLATE	1	1	1	1	1	
10	5BE-15668-00	STOPPER	1	1	1	1	1	
11	5BE-15674-00	GUIDE, RATCHET WHEEL	1	1	1	1	1	
12	5BE-15686-01	WASHER, LOCK	1	1	1	1	1	
13	90101-06001	BOLT	2	2	2	2	2	
14	93102-20108	OIL SEAL	1	1	1	1	1	
15	5BE-15651-00	GEAR, KICK IDLE	1	1	1	1	1	
16	90201-20276	WASHER, PLATE (1.0T)	1	1	1	1	1	
17	99009-20400	CIRCLIP	1	1	1	1	1	
18	5BE-15620-02	KICK CRANK ASSY	1	1	1	1	1	
19	3SP-15621-02	.BOSS, KICK CRANK	1	1	1	1	1	
20	90501-13720	.SPRING, COMPRESSION	1	1	1	1	1	
21	93501-04011	.BALL	1	1	1	1	1	
22	90152-06010	.SCREW, COUNTERSUNK	1	1	1	1	1	
23	93210-19216	.O-RING	1	1	1	1	1	
24	90105-08752	BOLT, WASHER BASED	1	1	1	1	1	
25	90201-087A9	WASHER, PLATE	1	1	1	1	1	

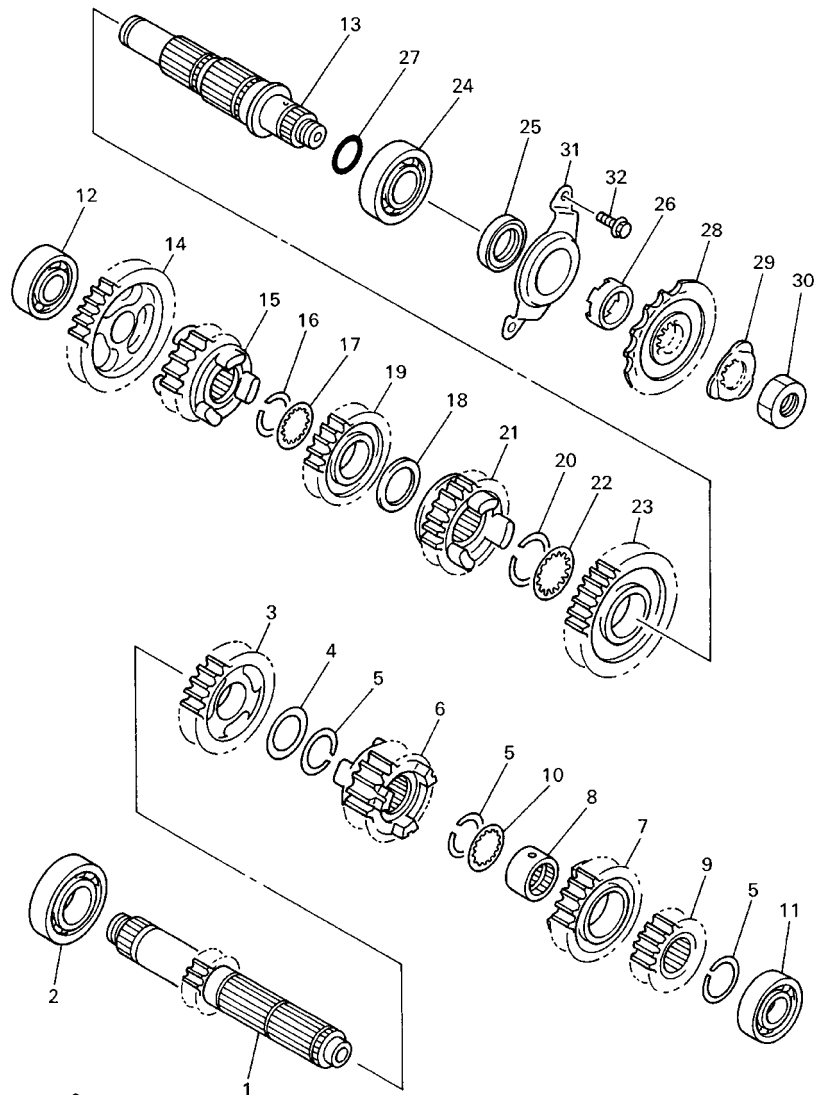
FIG. 15 CLUTCH



5BE100-8150

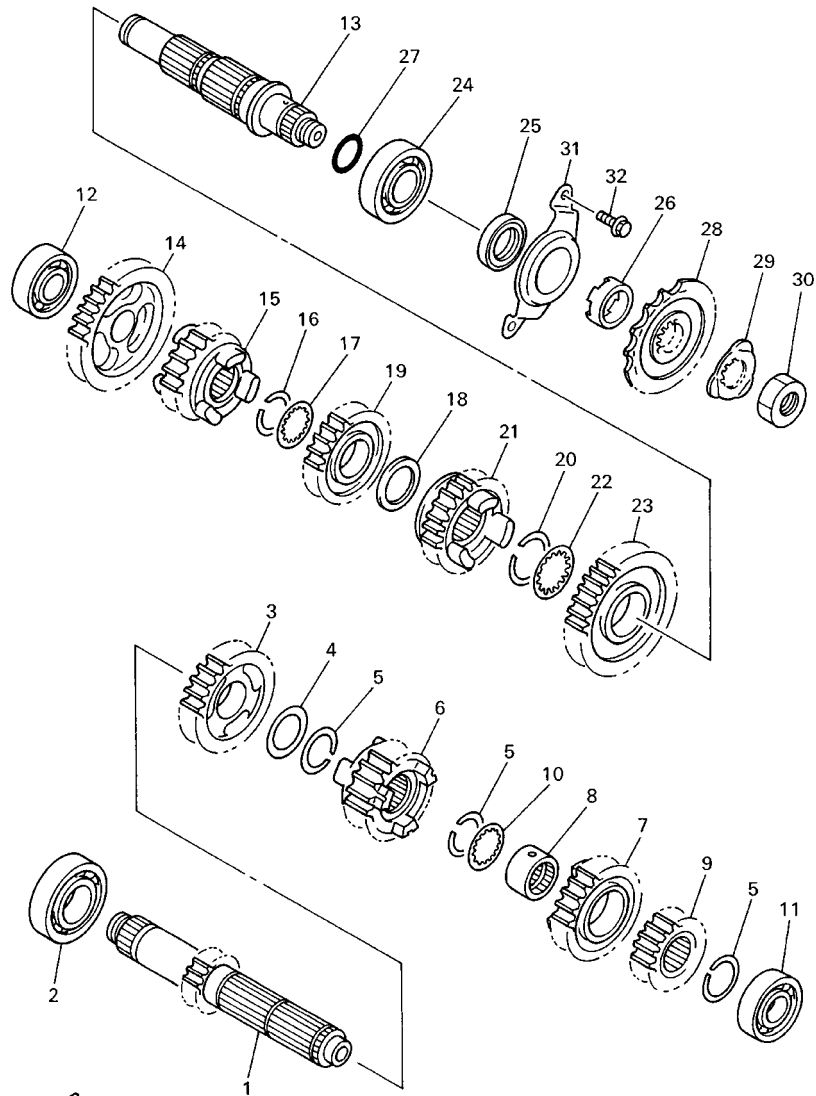
REF. NO.	PART NO.	DESCRIPTION	USA	CAN	OCE	EUR	JPN	REMARKS
1	5BE-16111-00	GEAR, PRIMARY DRIVE	1	1	1	1	1	
2	90215-21290	WASHER, LOCK	1	1	1	1	1	
3	90179-20255	NUT	1	1	1	1	1	
4	5BE-16150-00	PRIMARY DRIVEN GEAR COMP.	1	1	1	1	1	
5	2JN-16371-00	BOSS, CLUTCH	1	1	1	1	1	
6	3YF-16351-00	PLATE, PRESSURE 1	1	1	1	1	1	
7	360-16325-00	PLATE, CLUTCH 2	7	7	7	7	7	
8	5BE-16321-00	PLATE, FRICTION	7	7	7	7	7	
9	90501-23141	SPRING, COMPRESSION	5	5	5	5	5	
10	90159-06092	SCREW, WITH WASHER	5	5	5	5	5	
11	2JN-16154-00	PLATE, THRUST 1	1	1	1	1	1	
12	5BE-16331-00	PLATE, FRICTION 2	1	1	1	1	1	
13	90215-20231	WASHER, LOCK	1	1	1	1	1	
14	90170-20327	NUT	1	1	1	1	1	
15	5BE-16356-00	ROD, PUSH 1	1	1	1	1	1	
16	93340-21505	BEARING	1	1	1	1	1	
17	90201-125L6	WASHER, PLATE	1	1	1	1	1	
18	93440-10085	CIRCLIP	1	1	1	1	1	
19	5BE-16357-00	ROD, PUSH 2	1	1	1	1	1	
20	5BE-16381-00	PUSH LEVER COMP.	1	1	1	1	1	
21	93315-11206	BEARING	1	1	1	1	1	
22	93102-12224	OIL SEAL	1	1	1	1	1	
23	4JT-16384-00	PLATE, SEAT	1	1	1	1	1	
24	95027-06010	BOLT, FLANGE	1	1	1	1	1	
25	90508-142B5	SPRING, TORSION	1	1	1	1	1	

FIG. 16 TRANSMISSION



**FWD**  
5BE100-8160

REF. NO.	PART NO.	DESCRIPTION	USA	CAN	OCE	EUR	JPN	REMARKS
1	5BF-17411-00	AXLE, MAIN	1	1	1	1	1	
2	93306-20532	BEARING	1	1	1	1	1	
3	5BF-17151-00	GEAR, 5TH PINION	1	1	1	1	1	
4	90201-253K0	WASHER, PLATE (T=1.0)	1	1	1	1	1	
5	93440-25084	CIRCLIP	3	3	3	3	3	
6	5BF-17131-00	GEAR, 3RD PINION	1	1	1	1	1	
7	5BF-17141-00	GEAR, 4TH PINION	1	1	1	1	1	
8	90387-2113G	COLLAR	1	1	1	1	1	
9	5BF-17121-00	GEAR, 2ND PINION	1	1	1	1	1	
10	90209-21332	WASHER	1	1	1	1	1	
11	93306-00431	BEARING	1	1	1	1	1	
12	93306-00426	BEARING	1	1	1	1	1	
13	5BE-17421-00	AXLE, DRIVE	1	1	1	1	1	
14	5BF-17211-00	GEAR, 1ST WHEEL	1	1	1	1	1	
15	5BF-17251-00	GEAR, 5TH WHEEL	1	1	1	1	1	
16	93440-25084	CIRCLIP	1	1	1	1	1	
17	90209-21332	WASHER	1	1	1	1	1	
18	90201-253K0	WASHER, PLATE (T=1.0)	1	1	1	1	1	
19	5BF-17231-00	GEAR, 3RD WHEEL	1	1	1	1	1	
20	93440-28062	CIRCLIP	1	1	1	1	1	
21	5BF-17241-00	GEAR, 4TH WHEEL	1	1	1	1	1	
22	90209-26348	WASHER	1	1	1	1	1	
23	5BF-17221-00	GEAR, 2ND WHEEL	1	1	1	1	1	
24	93306-20593	BEARING	1	1	1	1	1	
25	93102-32480	OIL SEAL	1	1	1	1	1	
26	90387-2513F	COLLAR	1	1	1	1	1	
27	93210-22298	O-RING	1	1	1	1	1	

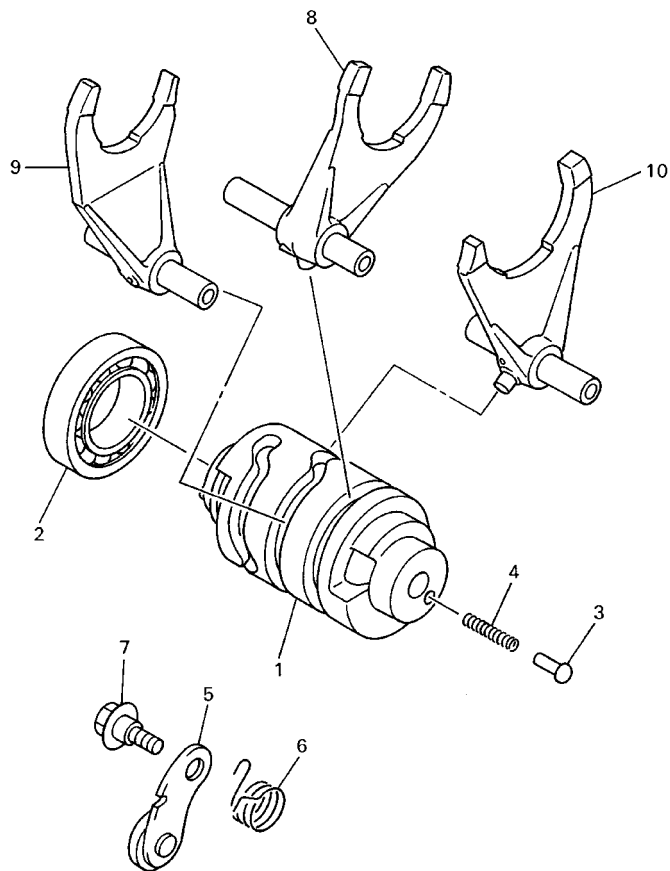


FWD  
5BE100-8160

FIG. 16 TRANSMISSION

REF. NO.	PART NO.	DESCRIPTION	USA	CAN	OCE	EUR	JPN	REMARKS
28	9383E-14210	SPROCKET, DRIVE (14T)	1	1	1	1	1	
29	90215-21256	WASHER, LOCK	1	1	1	1	1	
30	90179-20255	NUT	1	1	1	1	1	
31	5GR-17471-00	PLATE, COVER	1	1	1	1	1	
32	90105-06553	BOLT, WASHER BASED	2	2	2	2	2	
<hr/>								
<hr/>								
<hr/>								
<hr/>								
<hr/>								
<hr/>								
<hr/>								
<hr/>								

FIG. 17 SHIFT CAM. FORK

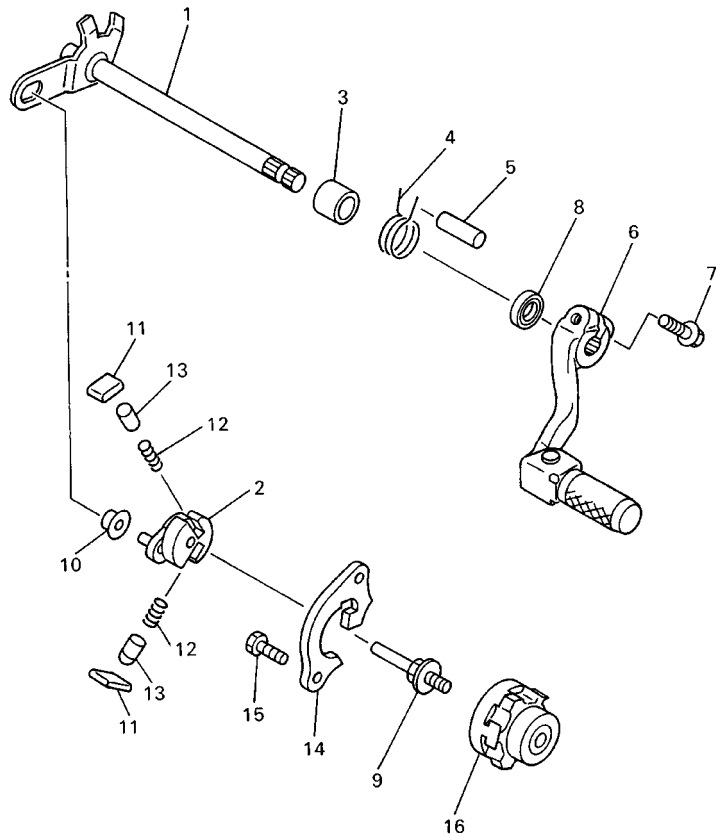


REF. NO.	PART NO.	DESCRIPTION	USA	CAN	OCE	EUR	JPN	REMARKS
1	5BE-18541-00	CAM, SHIFT	1	1	1	1	1	
2	93306-90501	BEARING	1	1	1	1	1	
3	4BA-18542-00	POINT, NEUTRAL	1	1	1	1	1	
4	90501-06022	SPRING, COMPRESSION	1	1	1	1	1	
5	3XK-18140-00	STOPPER LEVER ASSY	1	1	1	1	1	
6	90508-26561	SPRING, TORSION	1	1	1	1	1	
7	90109-063F8	BOLT	1	1	1	1	1	
8	5BE-18501-00	FORK, SHIFT 1	1	1	1	1	1	
9	5BE-18502-00	FORK, SHIFT 2	1	1	1	1	1	
10	5BE-18503-00	FORK, SHIFT 3	1	1	1	1	1	



5BE100-8170

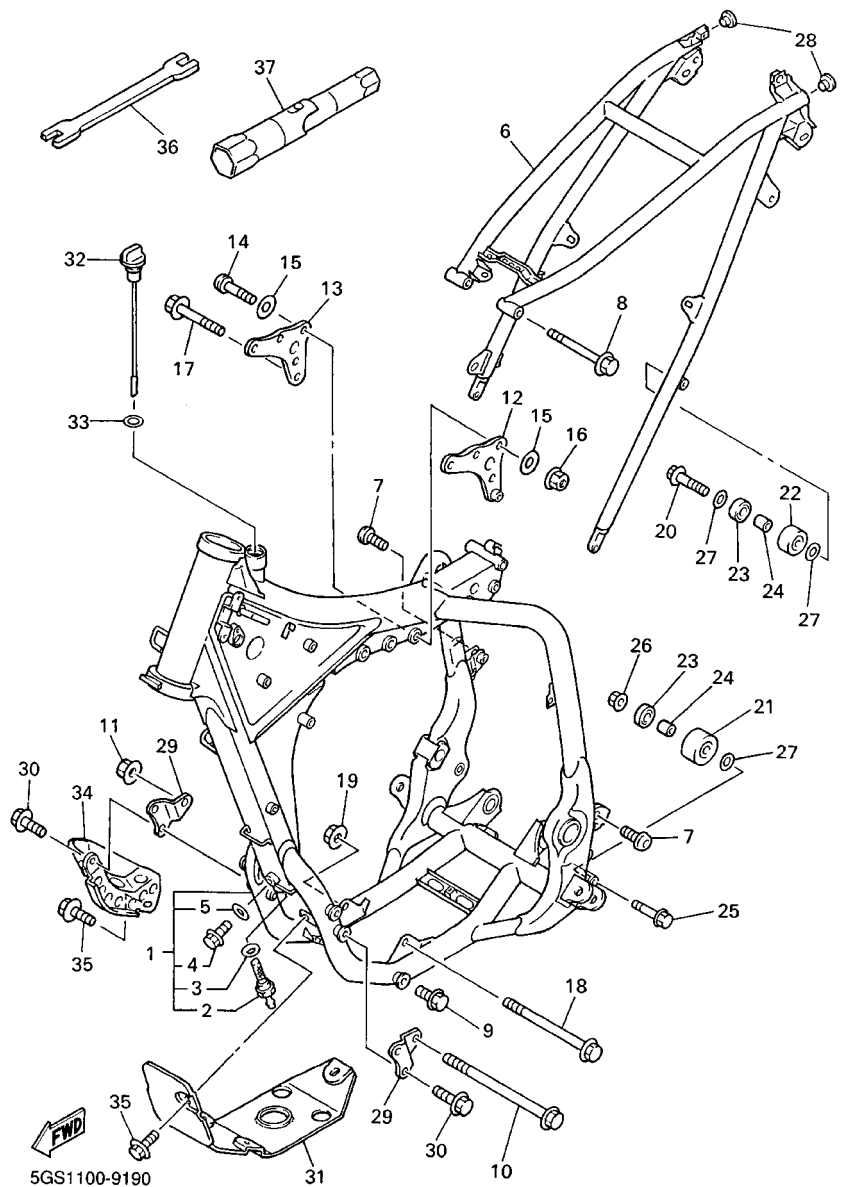
FIG. 18 SHIFT SHAFT



5BE100-8180

REF. NO.	PART NO.	DESCRIPTION	USA	CAN	OCE	EUR	JPN	REMARKS
1	3XK-18101-02	SHIFT SHAFT ASSY	1	1	1	1	1	
2	3XK-18122-00	LEVER, SHIFT 2	1	1	1	1	1	
3	90387-124F4	COLLAR	1	1	1	1	1	
4	90508-291A8	SPRING, TORSION	1	1	1	1	1	
5	93608-33046	PIN, DOWEL	1	1	1	1	1	
6	5BE-18110-00	SHIFT PEDAL ASSY	1	1	1	1	1	
7	95027-06020	BOLT, FLANGE	1	1	1	1	1	
8	93102-12106	OIL SEAL (SD 12-22-5 HS)	1	1	1	1	1	
9	3XJ-18173-00	PIN, SHIFT	1	1	1	1	1	
10	3XJ-18178-00	ROLLER, SHIFT LEVER	1	1	1	1	1	
11	3XJ-18182-00	PAWL, SHIFTER	2	2	2	2	2	
12	90501-052G5	SPRING, COMPRESSION	2	2	2	2	2	
13	3XJ-18184-00	PIN, PAWL	2	2	2	2	2	
14	5BE-18172-00	GUIDE, SHIFT	1	1	1	1	1	
15	90101-06664	BOLT	2	2	2	2	2	
16	4EW-18185-00	SEGMENT	1	1	1	1	1	

FIG. 19 FRAME



REF. NO.	PART NO.	DESCRIPTION	USA	CAN	OCÉ	EUR	JPN	REMARKS
1	5GS-21101-00-P0	FRONT FRAME COMP.	1	1	1	1	1	DPBMC
2	5BE-21756-00	.NET, FILTER	1	1	1	1	1	
3	90430-18130	.GASKET	1	1	1	1	1	
4	95827-08012	.BOLT, FLANGE	1	1	1	1	1	
5	90430-08119	.GASKET	1	1	1	1	1	
6	5BF-21190-00-P0	REAR FRAME COMP.	1	1	1	1	1	DPBMC
7	90110-08096	BOLT, HEXAGON SOCKET HEAD	2	2	2	2	2	
8	90105-08099	BOLT, WASHER BASED	1	1	1	1	1	
9	95827-08016	BOLT, FLANGE	1	1	1	1	1	
10	95817-10160	BOLT, FLANGE	1	1	1	1	1	
11	95607-10200	NUT, SELF-LOCKING	1	1	1	1	1	
12	5GR-21425-00	BRACKET, REAR UPPER 1	1	1	1	1	1	
13	5BE-21425-00	BRACKET, REAR UPPER 1	1	1	1	1	1	
14	92017-08055	BOLT, BUTTON HEAD	3	3	3	3	3	
15	90201-086P8	WASHER, PLATE	6	6	6	6	6	
16	90185-08169	NUT, SELF-LOCKING	3	3	3	3	3	
17	95817-10050	BOLT, FLANGE	1	1	1	1	1	
18	90105-10733	BOLT, WASHER BASED	1	1	1	1	1	
19	95607-10200	NUT, SELF-LOCKING	1	1	1	1	1	
20	95027-08040	BOLT, FLANGE	1	1	1	1	1	
21	3JD-22178-10	TENSIONER	1	1	1	1	1	
22	4EW-22178-00	TENSIONER	1	1	1	1	1	
23	93300-60804	BEARING	2	2	2	2	2	
24	90387-086N4	COLLAR	2	2	2	2	2	
25	95027-08065	BOLT, FLANGE	1	1	1	1	1	
26	95707-08500	NUT, FLANGE	1	1	1	1	1	
27	90201-086P8	WASHER, PLATE	3	3	3	3	3	



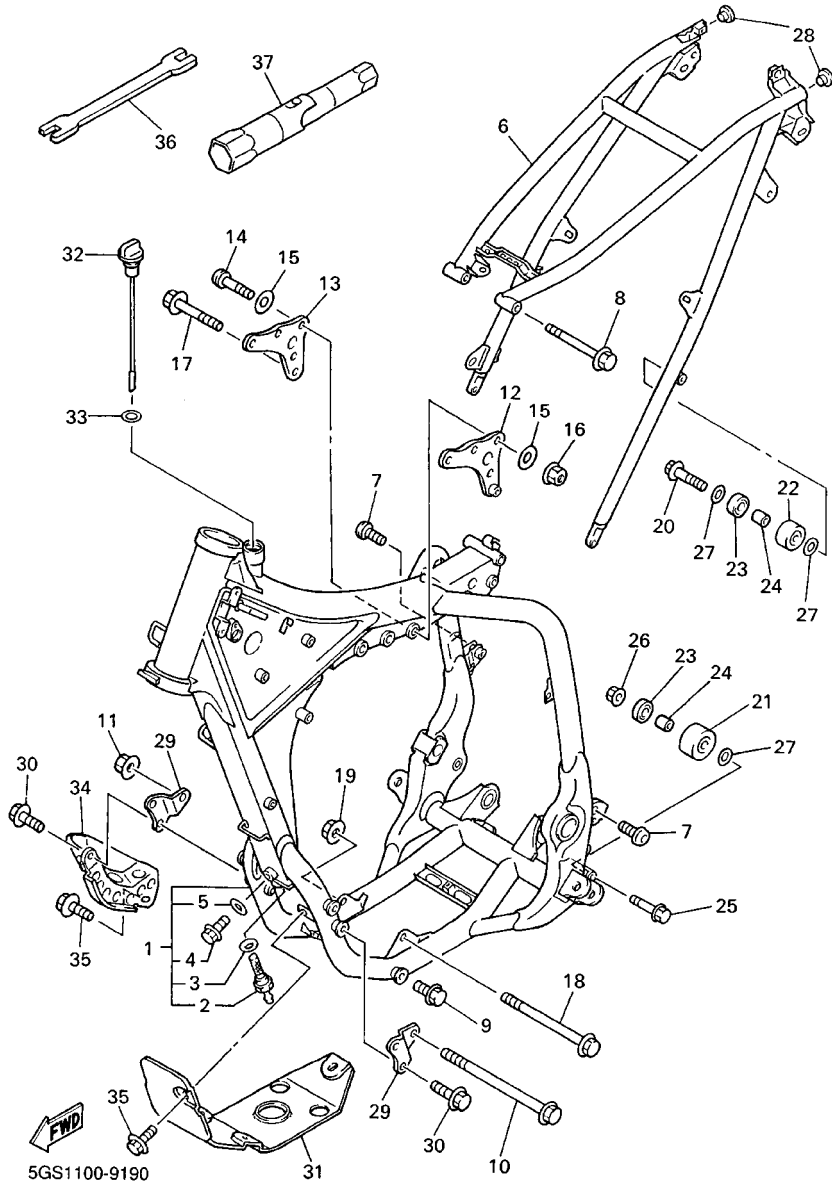
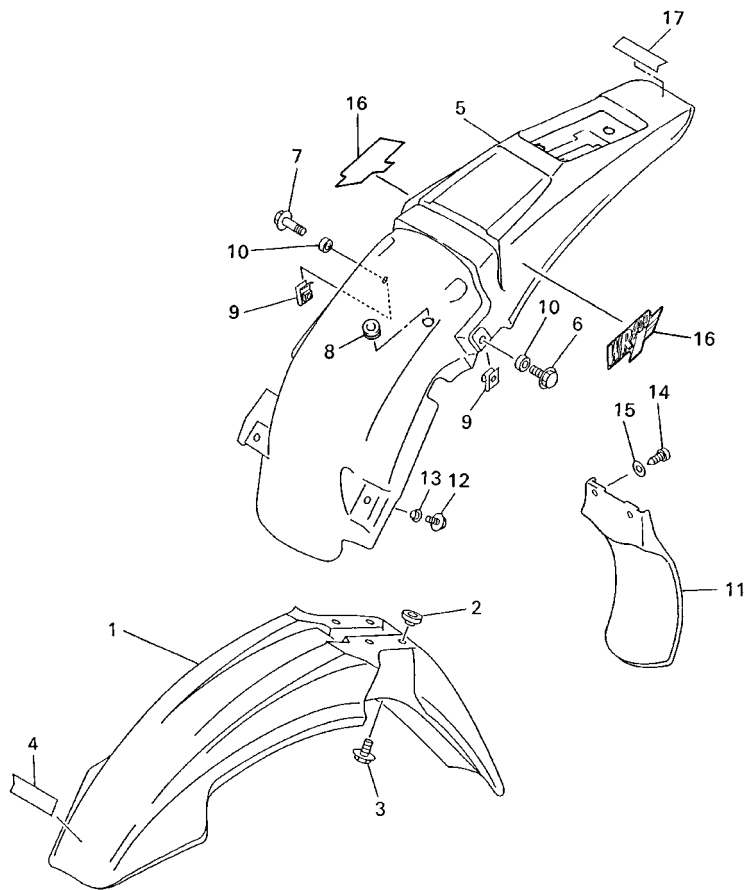


FIG. 19 FRAME

REF. NO.	PART NO.	DESCRIPTION	USA	CAN	OCE	EUR	JPN	REMARKS
28	90480-17218	GROMMET	2	2	2	2	2	
29	5BE-21417-00	BRACKET, FRONT LOWER 1	2	2	2	2	2	
30	95827-08016	BOLT, FLANGE	4	4	4	4	4	
31	5BE-21471-00	PROTECTOR, ENGINE	1	1	1	1	1	
32	5BE-15362-00	PLUG, OIL LEVEL	1	1	1	1	1	
33	93210-19123	O-RING	1	1	1	1	1	
34	5BE-2147A-00	GUARD, ENGINE 1	1	1	1	1	1	
35	95027-08012	BOLT, FLANGE	5	5	5	5	5	
36	5ET-28166-00	WRENCH, HEXAGON	1	1	1	1	1	
37	5BE-2814F-00	BOX, SPARK PLUG	1	1	1	1	1	

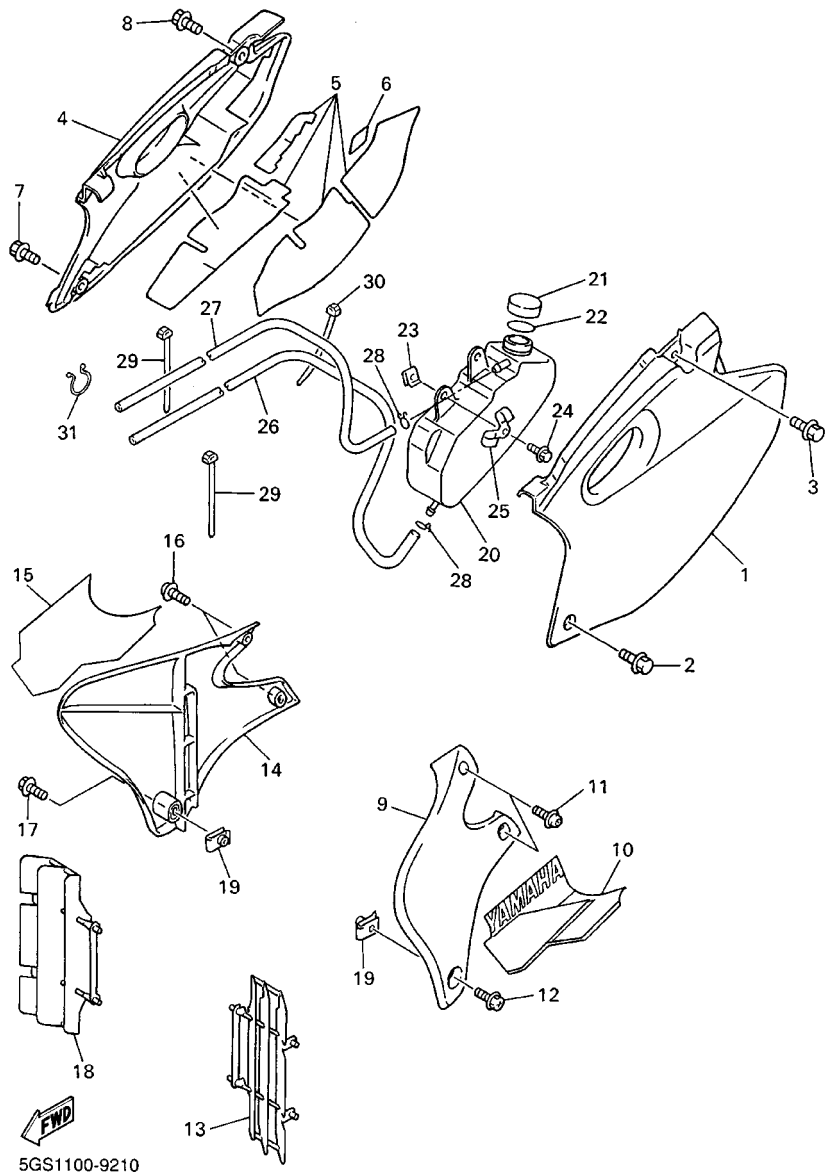
FIG. 20 FENDER



  
5GS1100-9200

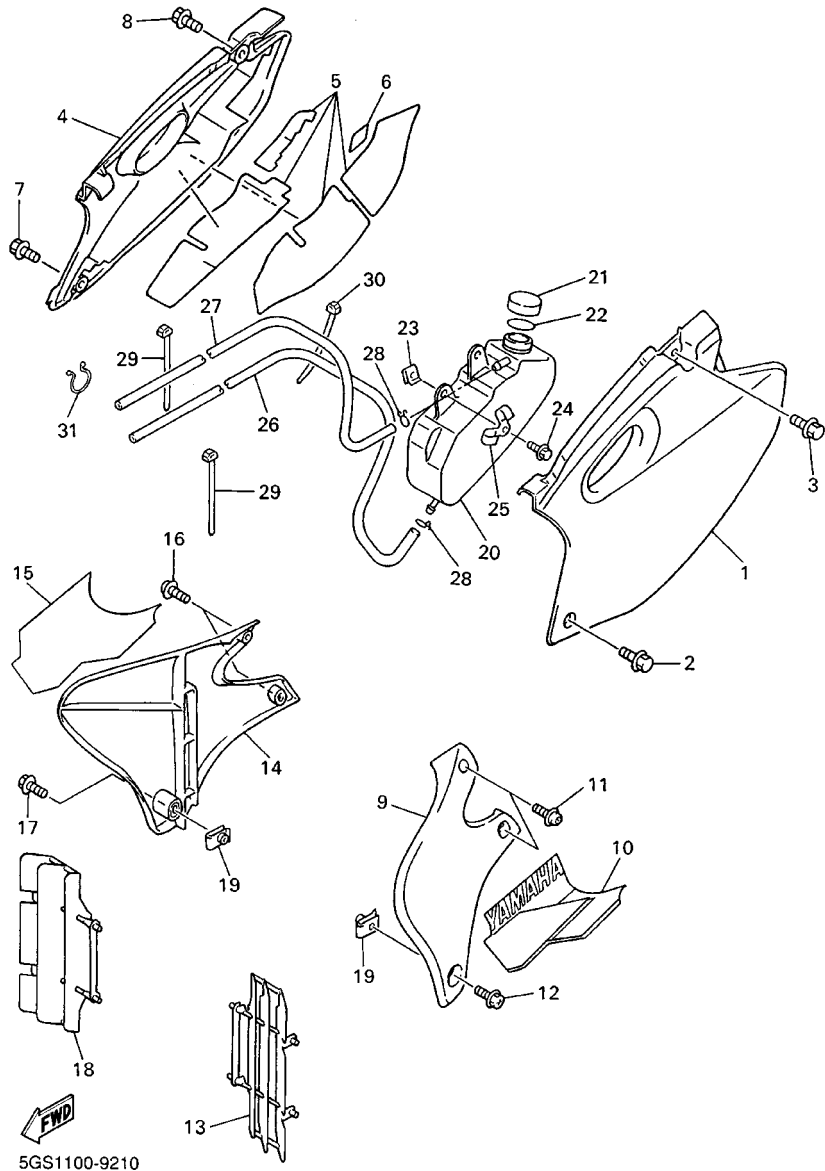
REF. NO.	PART NO.	DESCRIPTION	USA	CAN	OCE	EUR	JPN	REMARKS
1	4DA-21511-20	FENDER, FRONT	1	1	1	1	1	
2	3JD-21748-00	COLLAR	4	4	4	4	4	
3	90119-06096	BOLT, WITH WASHER	4	4	4	4	4	
4	99241-00080	EMBLEM, YAMAHA	1	1	1	1	1	
5	5BF-21611-00	FENDER, REAR	1	1	1	1	1	
6	95027-06012	BOLT, FLANGE	1	1	1	1	1	
7	90119-06163	BOLT, WITH WASHER	1	1	1	1	1	
8	90480-14323	GROMMET	1	1	1	1	1	
9	90183-06023	NUT, SPRING	2	2	2	2	2	
10	90387-0701A	COLLAR	2	2	2	2	2	
11	5BE-21642-00	GUARD, FLAP	1	1	1	1	1	
12	95027-06014	BOLT, FLANGE	2	2	2	2	2	
13	90387-0600F	COLLAR	2	2	2	2	2	
14	97707-60016	SCREW, TAPPING	2	2	2	2	2	
15	90201-06557	WASHER, PLATE	2	2	2	2	2	
16	5GS-2163G-00	EMBLEM 1	2	2	2	2	2	
17	99241-00080	EMBLEM, YAMAHA	1	1	1	1	1	

FIG. 21 SIDE COVER



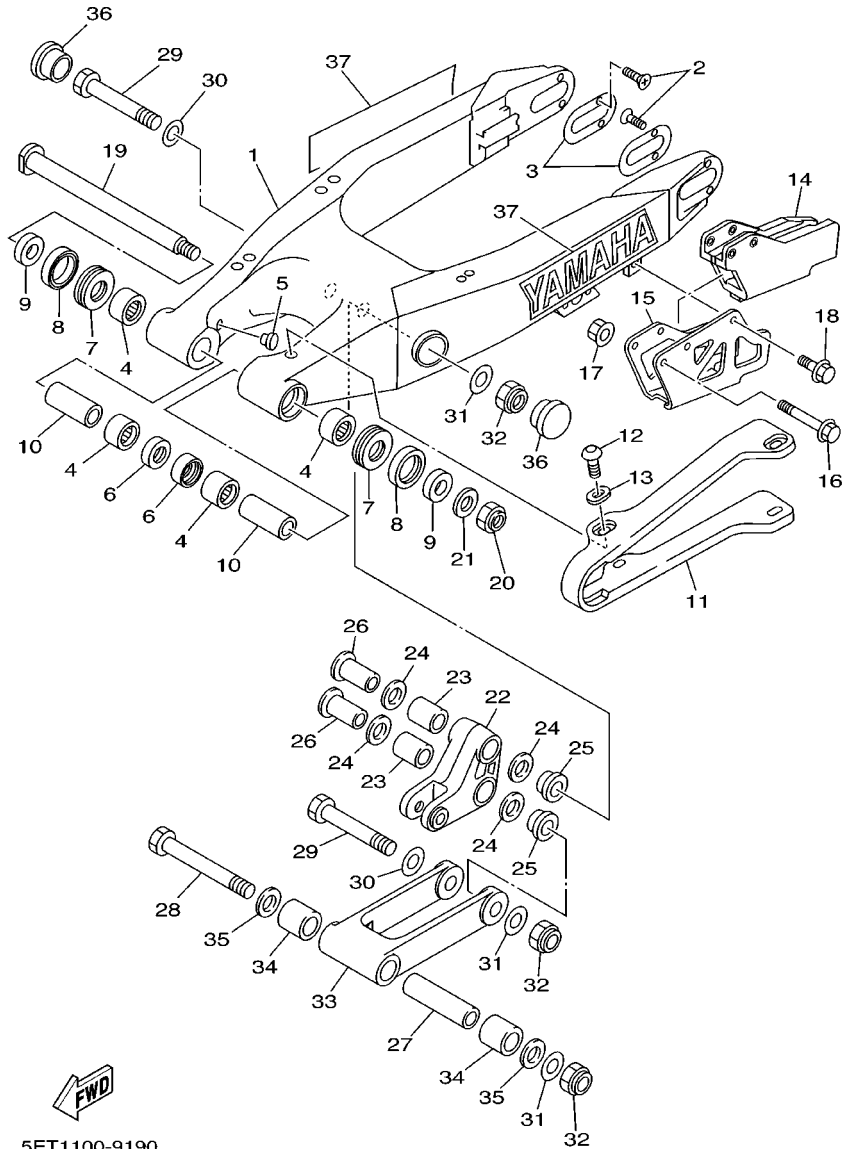
REF. NO.	PART NO.	DESCRIPTION	USA	CAN	OCE	EUR	JPN	REMARKS
1	5BF-21711-00	COVER, SIDE 1	1	1	1	1	1	
2	95827-06016	BOLT, FLANGE	1	1	1	1	1	
3	90119-08238	BOLT, WITH WASHER	1	1	1	1	1	
4	5BF-21721-00	COVER, SIDE 2	1	1	1	1	1	
5	5BF-2174A-00	INSULATOR, SIDE COVER	1	1	1	1	1	
6	3FY-21575-01	SEAL 1	1	1	1	1	1	
7	95827-06016	BOLT, FLANGE	1	1	1	1	1	
8	90119-08238	BOLT, WITH WASHER	1	1	1	1	1	
9	5BE-21731-10	COVER, SIDE 3	1	1	1	1	1	
10	5GS-2173E-00	GRAPHIC 1	1	1	1	1	1	
11	90159-06182	SCREW, WITH WASHER	2	2	2	2	2	
12	90159-06078	SCREW, WITH WASHER	1	1	1	1	1	
13	5BF-2172A-00	PANEL 1	1	1	1	1	1	
14	5BE-21741-10	COVER, SIDE 4	1	1	1	1	1	
15	5GS-2173F-00	GRAPHIC 2	1	1	1	1	1	
16	90159-06182	SCREW, WITH WASHER	2	2	2	2	2	
17	90159-06078	SCREW, WITH WASHER	1	1	1	1	1	
18	5BF-2172A-00	PANEL 1	1	1	1	1	1	
19	90183-06069	NUT, SPRING	2	2	2	2	2	
20	5GS-21871-00	TANK, RECOVERY	1	1	1	1	1	
21	26H-21875-00	CAP	1	1	1	1	1	
22	26H-21874-00	GASKET	1	1	1	1	1	
23	90183-06023	NUT, SPRING	1	1	1	1	1	
24	90119-06060	BOLT, WITH WASHER	1	1	1	1	1	
25	5BF-21823-00	CLAMP, HOSE	1	1	1	1	1	
26	91A20-05130	TUBE, FLEXIBLE VINYL	1	1	1	1	1	
27	91A21-05105	TUBE, FLEXIBLE	1	1	1	1	1	

FIG. 21 SIDE COVER



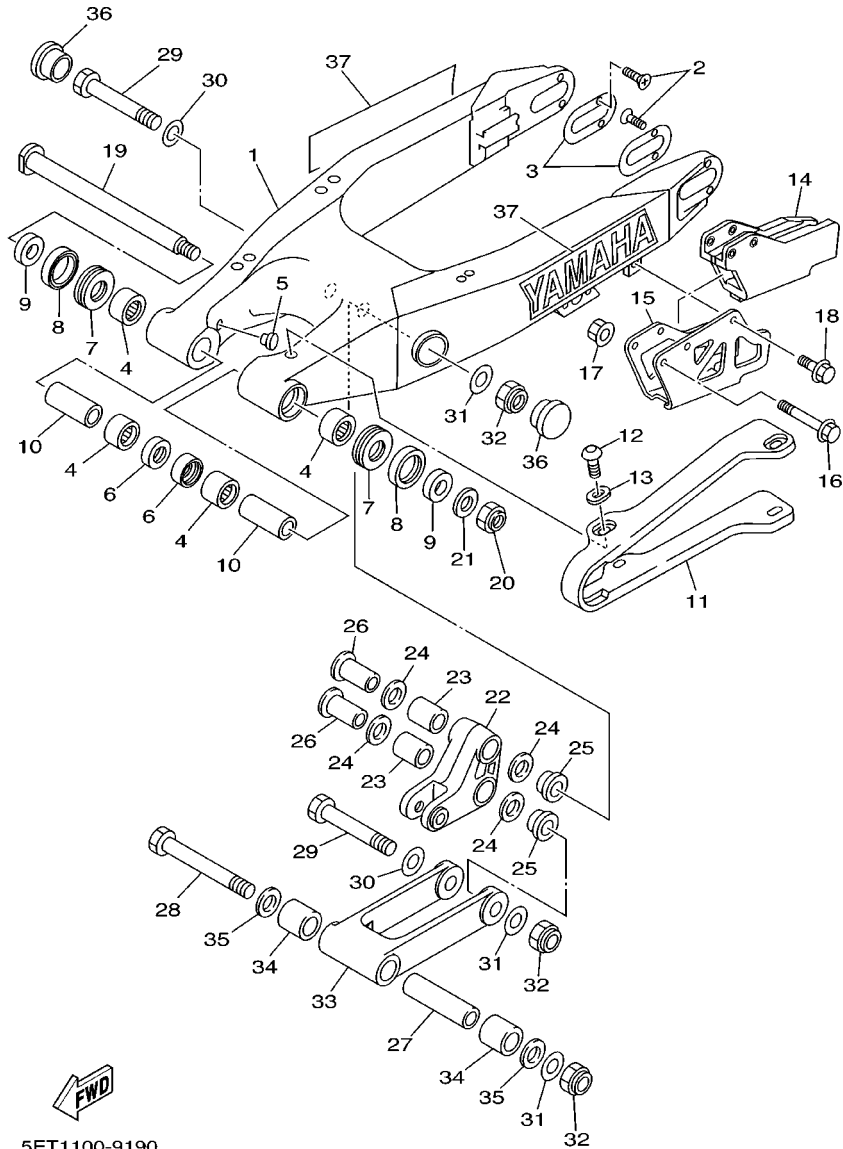
REF. NO.	PART NO.	DESCRIPTION	USA	CAN	OCE	EUR	JPN	REMARKS
28	90467-08017	CLIP	3	3	3	3	3	
29	90464-13077	CLAMP	2	2	2	2	2	
30	90464-13073	CLAMP	1	1	1	1	1	
31	90464-16039	CLAMP	1	1	1	1	1	
-----								
-----								
-----								
-----								
-----								
-----								
-----								
-----								
-----								

FIG. 22 REAR ARM



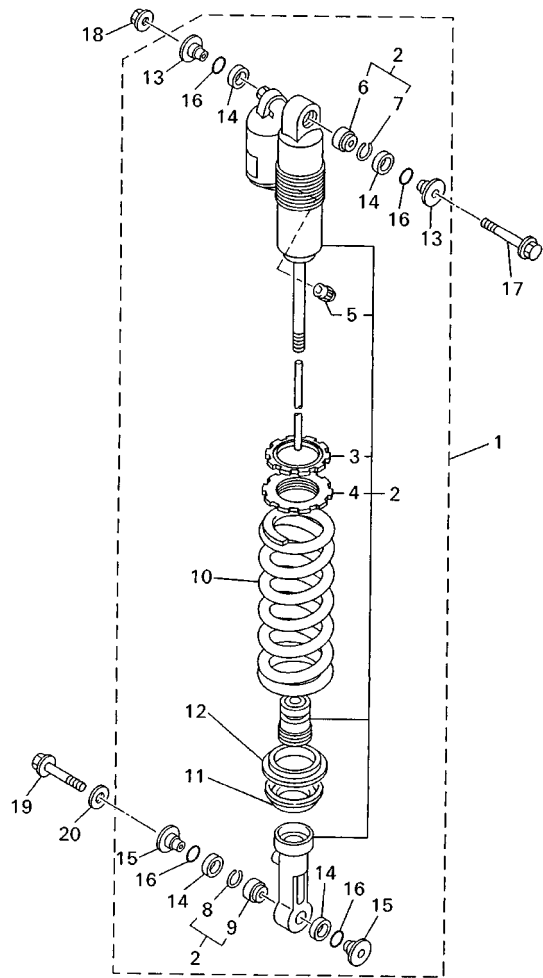
REF. NO.	PART NO.	DESCRIPTION	USA	CAN	OCE	EUR	JPN	REMARKS
1	5CU-22110-00	REAR ARM COMP.	1	1	1	1	1	
2	90151-04048	SCREW, COUNTERSUNK	4	4	4	4	4	
3	5ET-22355-00	PATCH	2	2	2	2	2	
4	93317-22262	BEARING	4	4	4	4	4	
5	90338-16148	PLUG	2	2	2	2	2	
6	93106-22019	OIL SEAL (DC 22-28-8)	2	2	2	2	2	
7	93342-22217	BEARING	2	2	2	2	2	
8	93109-28043	OIL SEAL	2	2	2	2	2	
9	90387-1714R	COLLAR	2	2	2	2	2	
10	90387-1714S	COLLAR	2	2	2	2	2	
11	4EW-22151-20	SEAL, GUARD	1	1	1	1	1	
12	90110-05201	BOLT, HEXAGON SOCKET HEAD	4	4	4	4	4	
13	5ET-22156-00	WASHER, PLATE	4	4	4	4	4	
14	4XM-22199-00	SUPPORT, CHAIN	1	1	1	1	1	
15	4XM-22128-00	COVER, THRUST 1	1	1	1	1	1	
16	95027-06050	BOLT, FLANGE	2	2	2	2	2	
17	90179-06568	NUT	2	2	2	2	2	
18	95027-06010	BOLT, FLANGE	1	1	1	1	1	
19	5DH-22141-00	SHAFT, PIVOT	1	1	1	1	1	
20	90185-16127	NUT, SELF-LOCKING	1	1	1	1	1	
21	90201-164H4	WASHER, PLATE	1	1	1	1	1	
22	5ET-2217A-00	ARM, RELAY	1	1	1	1	1	
23	93315-32056	BEARING	2	2	2	2	2	
24	93109-20076	OIL SEAL	4	4	4	4	4	
25	90387-164N2	COLLAR	2	2	2	2	2	
26	90387-164N3	COLLAR	2	2	2	2	2	
27	90387-167Y9	COLLAR	1	1	1	1	1	

FIG. 22 REAR ARM



REF. NO.	PART NO.	DESCRIPTION	USA	CAN	OCE	EUR	JPN	REMARKS
28	90109-147F2	BOLT	1	1	1	1	1	
29	90109-142F4	BOLT	2	2	2	2	2	
30	90201-164H4	WASHER, PLATE	2	2	2	2	2	
31	90201-14740	WASHER, PLATE	3	3	3	3	3	
32	90185-14112	NUT, SELF-LOCKING	3	3	3	3	3	
33	5DH-2217F-00	ROD, CONNECTING 1	1	1	1	1	1	
34	93315-32056	BEARING	2	2	2	2	2	
35	93109-20076	OIL SEAL	2	2	2	2	2	
36	1HX-2135F-10	COVER	2	2	2	2	2	
37	99244-00200	EMBLEM, YAMAHA	2	2	2	2	2	
-----								
-----								
-----								
-----								
-----								
-----								

FIG. 23 REAR SUSPENSION



5GR100-9230

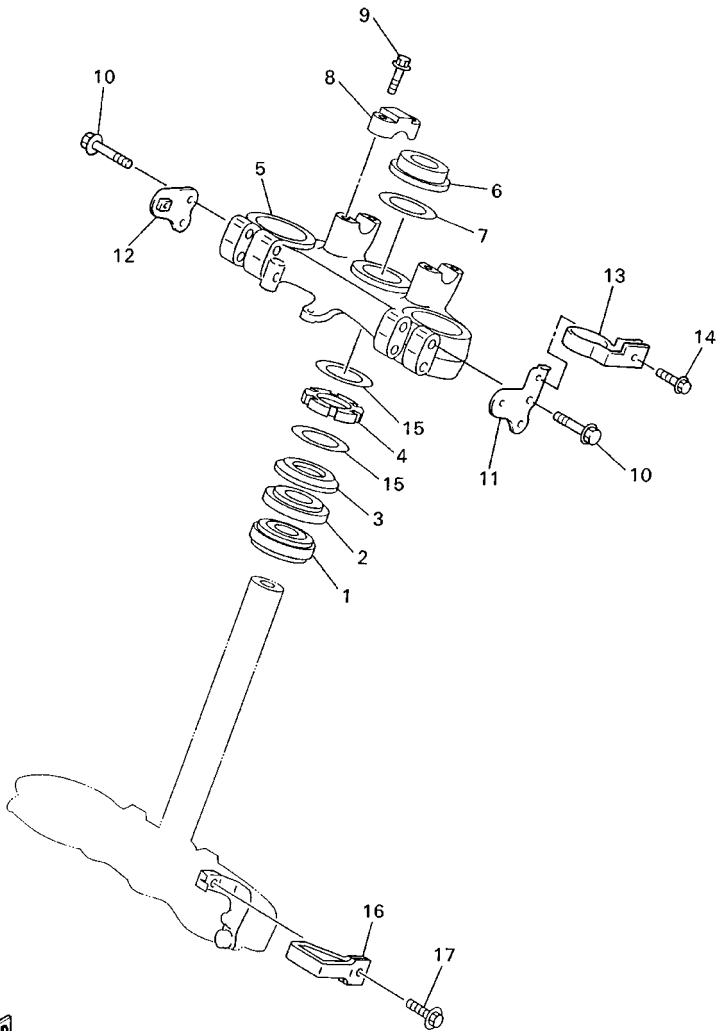
REF. NO.	PART NO.	DESCRIPTION	USA	CAN	OCE	EUR	JPN	REMARKS
1	5GS-22210-00	SHOCK ABSORBER ASSY, REAR	1					
	5GS-22210-30	SHOCK ABSORBER ASSY, REAR		1				
	5GS-22210-40	SHOCK ABSORBER ASSY, REAR			1			
	5GS-22210-10	SHOCK ABSORBER ASSY, REAR				1		
	5GS-22210-20	SHOCK ABSORBER ASSY, REAR					1	
2	5GS-22201-00	.DAMPER SUB ASSY	1					
	5GS-22201-30	.DAMPER SUB ASSY		1				
	5GS-22201-40	DAMPER SUB ASSY			1			
	5GS-22201-10	.DAMPER SUB ASSY				1		
	5GS-22201-20	.DAMPER SUB ASSY					1	
3	3SP-22234-00	..GUIDE, SPRING 3	1	1	1	1	1	
4	3SP-22213-00	..SEAT, SPRING UPPER	1	1	1	1	1	
5	509-23184-L0	..CAP, AIR VALVE	1	1	1	1	1	
6	4JX-22226-00	..BUSH, SHOCK ABSORBER LOWER	1	1	1	1	1	
7	5DH-23183-00	..CIRCLIP	1	1	1	1	1	
8	5DH-23183-00	..CIRCLIP	1	1	1	1	1	
9	4JX-22226-00	..BUSH, SHOCK ABSORBER LOWER	1	1	1	1	1	
10	5DH-22212-30	..SPRING (K=5.0)	1	1	1			
	5DH-22212-20	..SPRING (K=4.8)				1	1	
11	5DH-22214-00	..GUIDE, SPRING 1	1	1	1	1	1	
12	5DH-22224-00	..GUIDE, SPRING 2	1	1	1	1	1	
13	5DH-22253-00	..COLLAR, DISTANCE	2	2	2	2	2	
14	3JE-22475-00	..SEAL, DUST	4	4	4	4	4	
15	4EW-22253-00	..COLLAR, DISTANCE	2	2	2	2	2	
16	4EW-22474-00	..SEAL, RING	4	4	4	4	4	
17	90105-10323	BOLT, WASHÉR BASÉD	1	1	1	1	1	
18	95607-10200	NUT, SELF-LOCKING	1	1	1	1	1	





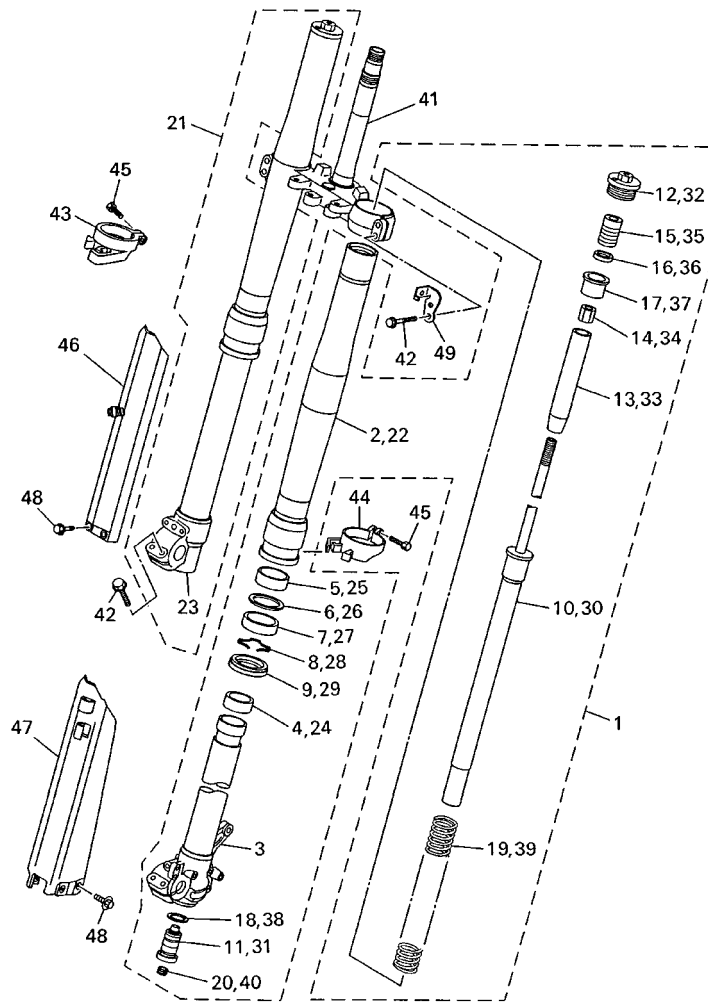
FIG. 24 STEERING

REF. NO.	PART NO.	DESCRIPTION	USA	CAN	OCE	EUR	JPN	REMARKS
1	93332-00081	BEARING	1	1	1	1	1	
2	93332-00068	BEARING	1	1	1	1	1	
3	4EW-23416-00	COVER, BALL RACE 2	1	1	1	1	1	
4	90179-28650	NUT	1	1	1	1	1	
5	5BF-23435-00	CROWN, HANDLE	1	1	1	1	1	
6	90170-24373	NUT	1	1	1	1	1	
7	90201-247L2	WASHER, PLATE	1	1	1	1	1	
8	3SP-23441-00	HOLDER, HANDLE UPPER	2	2	2	2	2	
9	95027-08035	BOLT, FLANGE	4	4	4	4	4	
10	95027-08040	BOLT, FLANGE	4	4	4	4	4	
11	4GY-2831V-00	STAY, HEAD LIGHT 1	1	1	1	1	1	
12	4GY-2832V-00	STAY, HEAD LIGHT 2	1	1	1	1	1	
13	4GY-23389-00	GUIDE, CABLE	1	1	1	1	1	
14	90105-05361	BOLT, WASHER BASED	1	1	1	1	1	
15	90201-286K9	WASHER, PLATE	2	2	2	2	2	
16	4DA-23389-00	GUIDE, CABLE	1	1	1	1	1	
17	90105-05361	BOLT, WASHER BASED	1	1	1	1	1	



5BF100-8240

FIG. 25 FRONT FORK

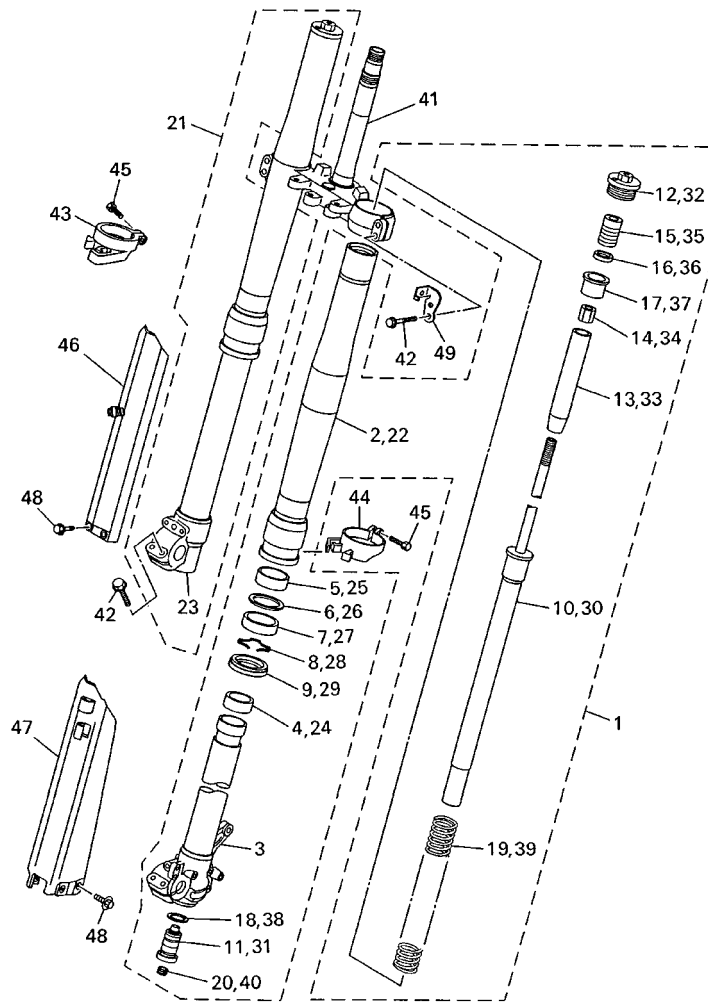


REF. NO.	PART NO.	DESCRIPTION	USA	CAN	OCE	EUR	JPN	REMARKS
1	5GS-23102-L0	FRONT FORK ASSY (L.H)	1	1	1		1	
	5GS-23102-M0	FRONT FORK ASSY (L.H)				1		
2	5ET-23136-L0	.TUBE, OUTER (RIGHT)	1	1	1	1	1	
3	5DH-23120-L0	.INNER TUBE COMP.2	1	1	1	1	1	
4	5ET-23171-L0	.PISTON, FRONT FORK	1	1	1	1	1	
5	5ET-23125-L0	.METAL, SLIDE 1	1	1	1	1	1	
6	4SS-23146-L0	.WASHER, OIL SEAL	1	1	1	1	1	
7	5ET-23145-L0	.OIL SEAL	1	1	1	1	1	
8	4SS-23153-L0	.RING, SNAP	1	1	1	1	1	
9	4SS-23144-L0	.SEAL, DUST	1	1	1	1	1	
10	5GR-23170-L0	.CYLINDER COMP., FRONT FORK	1	1	1		1	
	5GS-23170-L0	.CYLINDER COMP., FRONT FORK					1	
11	5GS-2316A-L0	.VALVE COMP.	1	1	1		1	
	5EN-2316A-L0	.VALVE COMP.					1	
12	5DH-23111-L0	.BOLT, CAP	1	1	1	1	1	
13	5DH-23142-L0	.SEAT, SPRING UPPER	1	1	1	1	1	
14	5ET-23393-L0	.NUT, SPECIAL	1	1	1	1	1	
15	5DH-23195-L0	.RUBBER	1	1	1	1	1	
16	5DH-23149-L0	.WASHER, SPRING UPPER	1	1	1	1	1	
17	5DH-23118-L0	.SPACER	1	1	1	1	1	
18	4SS-23158-L0	.GASKET	1	1	1	1	1	
19	5GR-23141-L0	.SPRING, FRONT FORK (K=0.46)	1	1	1		1	
	4SR-23141-L0	.SPRING, FRONT FORK (K=0.42)					1	
20	3JD-2312G-L0	.PLUG	1	1	1	1	1	
21	5GS-23103-L0	FRONT FORK ASSY (R.H)	1	1	1		1	
	5GS-23103-M0	FRONT FORK ASSY (R.H)					1	
22	5ET-23136-L0	.TUBE, OUTER (RIGHT)	1	1	1	1	1	



5GS1100-9250

FIG. 25 FRONT FORK

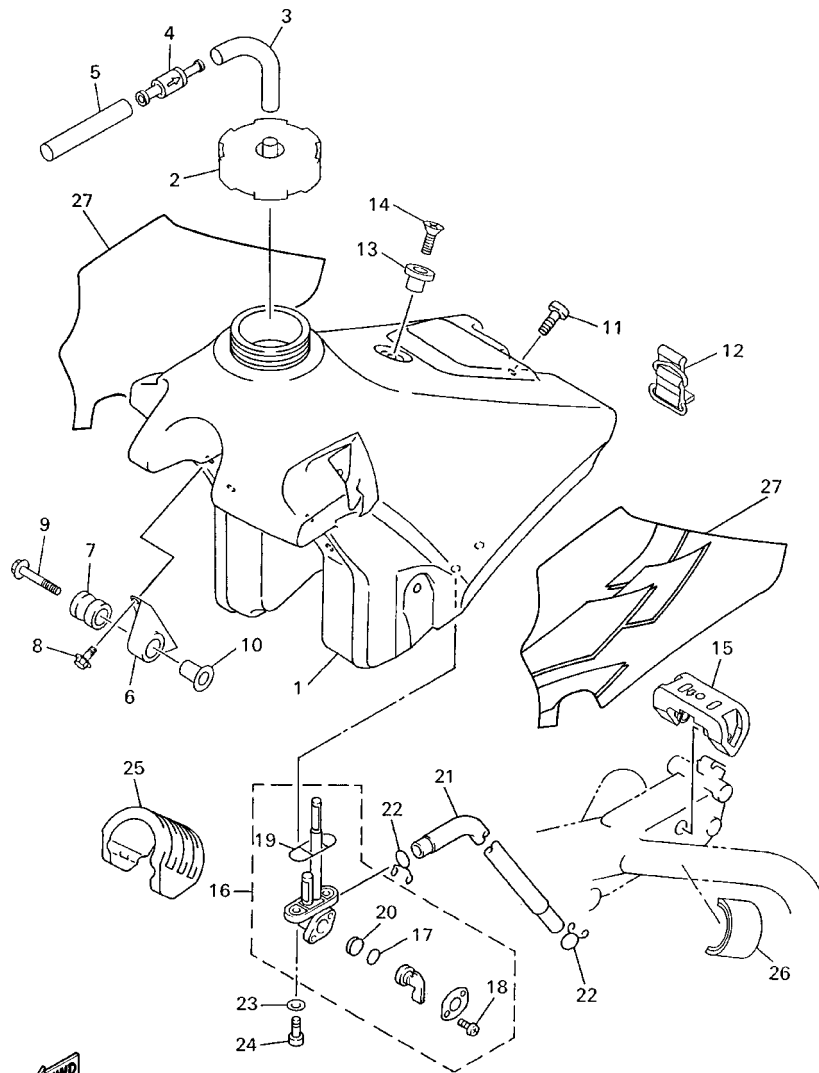


5GS1100-9250

REF. NO.	PART NO.	DESCRIPTION	USA	CAN	OCE	EUR	JPN	REMARKS
23	5BF-23110-L0	.INNER TUBE COMP.1	1	1	1	1	1	
24	5ET-23171-L0	.PISTON, FRONT FORK	1	1	1	1	1	
25	5ET-23125-L0	.METAL, SLIDE 1	1	1	1	1	1	
26	4SS-23146-L0	.WASHER, OIL SEAL	1	1	1	1	1	
27	5ET-23145-L0	.OIL SEAL	1	1	1	1	1	
28	4SS-23153-L0	.RING, SNAP	1	1	1	1	1	
29	4SS-23144-L0	.SEAL, DUST	1	1	1	1	1	
30	5GR-23170-L0	.CYLINDER COMP., FRONT FORK	1	1	1		1	
	5GS-23170-L0	.CYLINDER COMP., FRONT FORK					1	
31	5GS-2316A-L0	.VALVE COMP.	1	1	1		1	
	5EN-2316A-L0	.VALVE COMP.					1	
32	5DH-23111-L0	.BOLT, CAP	1	1	1	1	1	
33	5DH-23142-L0	.SEAT, SPRING UPPER	1	1	1	1	1	
34	5ET-23393-L0	.NUT, SPECIAL	1	1	1	1	1	
35	5DH-23195-L0	.RUBBER	1	1	1	1	1	
36	5DH-23149-L0	.WASHER, SPRING UPPER	1	1	1	1	1	
37	5DH-23118-L0	.SPACER	1	1	1	1	1	
38	4SS-23158-L0	.GASKET	1	1	1	1	1	
39	5GR-23141-L0	.SPRING, FRONT FORK (K=0.46)	1	1	1		1	
	4SR-23141-L0	.SPRING, FRONT FORK (K=0.42)					1	
40	3JD-2312G-L0	.PLUG	1	1	1	1	1	
41	5BF-23340-L0	UNDER BRACKET COMP.	1	1	1	1	1	
42	95021-08040	BOLT, FLANGE	8	8	8	8	8	
43	4SS-2314G-L0	PROTECTOR GUIDE COMP., 2	1	1	1	1	1	
44	5DH-2314F-L0	PROTECTOR GUIDE COMP., 1	1	1	1	1	1	
45	4SS-23346-L0	BOLT 1	2	2	2	2	2	
46	5BF-2314J-00	PROTECTOR COMP., 2	1	1	1	1	1	



FIG. 26 FUEL TANK

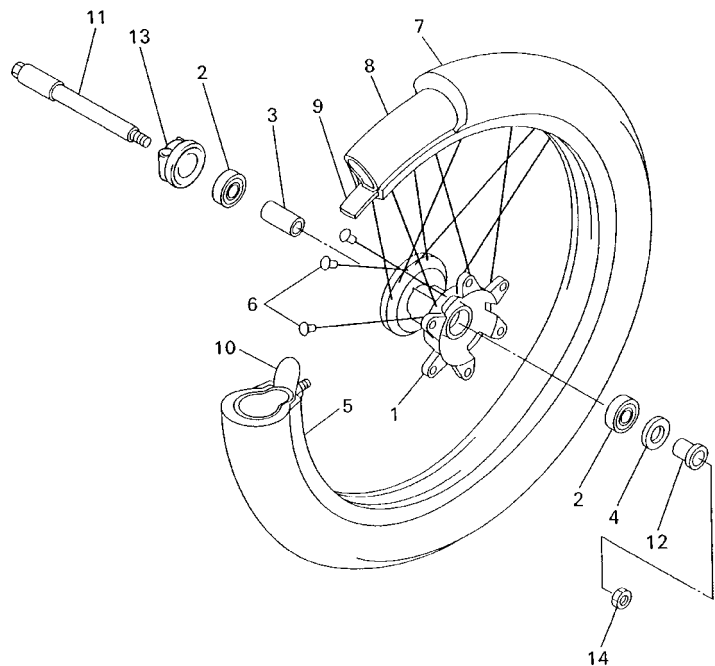


5GS1100-9260

REF. NO.	PART NO.	DESCRIPTION	USA	CAN	OCE	EUR	JPN	REMARKS
1	5GS-24110-00	FUEL TANK COMP.	1	1	1	1	1	
2	1UY-24610-00	CAP ASSY	1	1	1	1	1	
3	90445-09220	HOSE	1	1	1	1	1	
4	3XJ-24380-00	PIPE JOINT ASSY	1	1	1	1	1	
5	90445-09100	HOSE	1	1	1	1	1	
6	24X-24144-00	HOLDER, DAMPER	2	2	2	2	2	
7	90480-18549	GROMMET	2	2	2	2	2	
8	95027-06016	BOLT, FLANGE	4	4	4	4	4	
9	90119-06214	BOLT, WITH WASHER	2	2	2	2	2	
10	3JD-24186-00	WASHER, SPECIAL	2	2	2	2	2	
11	98907-06020	SCREW, BIND	1	1	1	1	1	
12	3SP-24173-00	BAND, TANK FITTING 1	1	1	1	1	1	
13	4EW-2412F-00	BRACKET, SEAT	1	1	1	1	1	
14	98707-06025	SCREW, FLAT HEAD	1	1	1	1	1	
15	4SS-24181-00	DAMPER, LOCATING 1	1	1	1	1	1	
16	2GU-24500-01	FUEL COCK ASSY 1	1	1	1	1	1	
17	3AJ-24534-00	.SEAL, COCK	1	1	1	1	1	
18	97801-03008	.SCREW, PAN HEAD	2	2	2	2	2	
19	4X8-24512-00	.O-RING	1	1	1	1	1	
20	3AJ-24523-00	.VALVE PACKING	1	1	1	1	1	
21	90445-114K8	HOSE	1	1	1	1	1	
22	90467-10008	CLIP	2	2	2	2	2	
23	90202-05193	WASHER, PLATE	2	2	2	2	2	
24	90149-06011	SCREW	2	2	2	2	2	
25	5BE-24182-00	DAMPER, LOCATING 2	1	1	1	1	1	
26	3V6-22358-00	SEAL 1	2	2	2	2	2	
27	5GS-24240-00	GRAPHIC SET	1	1	1	1	1	



FIG. 28 FRONT WHEEL

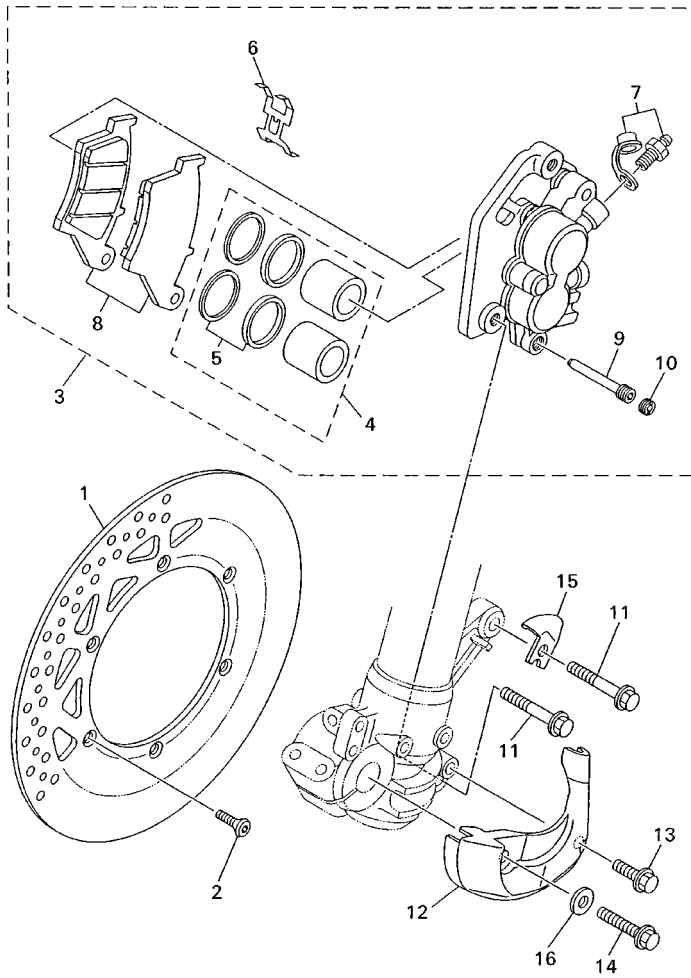


REF. NO.	PART NO.	DESCRIPTION	USA	CAN	OCE	EUR	JPN	REMARKS
1	5BF-25111-00	HUB, FRONT	1	1	1	1	1	
2	93306-90403	BEARING	2	2	2	2	2	
3	5DH-25117-00	SPACER, BEARING	1	1	1	1	1	
4	93102-26468	OIL SEAL	1	1	1	1	1	
5	94416-21613	RIM (1.60-21)	1	1	1	1	1	
6	4DA-25104-00	SPOKE SET, FRONT	1	1	1	1	1	
7	94108-21008	TIRE (80/100-21 51M D739F)	1	1	1			DUNLOP(FOR ZAF)
	*	TIRE (90/90-21)				1	1	LM MICHELIN (FOR OCE)
	94108-2115D	TIRE (80/100-21 51M M59)					1	BRIDGESTONE
8	94227-21101	TUBE (80/100-21 TR4 BTL)	1	1	1			DUNLOP(FOR ZAF)
	*	TUBE (90/90-21)				1	1	LM MICHELIN (FOR OCE)
	94209-21229	TUBE (80/100C-21 TR4)					1	BRIDGESTONE
9	94309-21161	BAND, RIM (70-80/100-21)	1	1	1			DUNLOP(FOR ZAF)
	*	BAND, RIM (2.75-21)				1	1	LM MICHELIN (FOR OCE)
	94330-21084	BAND, RIM (3.00-21)					1	BRIDGESTONE
10	2J5-25394-01	SPACER, BEAD	1	1	1	1	1	
11	5BE-25181-00	AXLE, WHEEL	1	1	1	1	1	
12	5DH-25183-00	COLLAR, WHEEL	1	1	1	1	1	
13	5BF-25190-00	GEAR UNIT ASSY	1	1	1	1	1	
14	90179-16672	NUT	1	1	1	1	1	



5BF100-8280

FIG. 29 FRONT BRAKE CALIPER



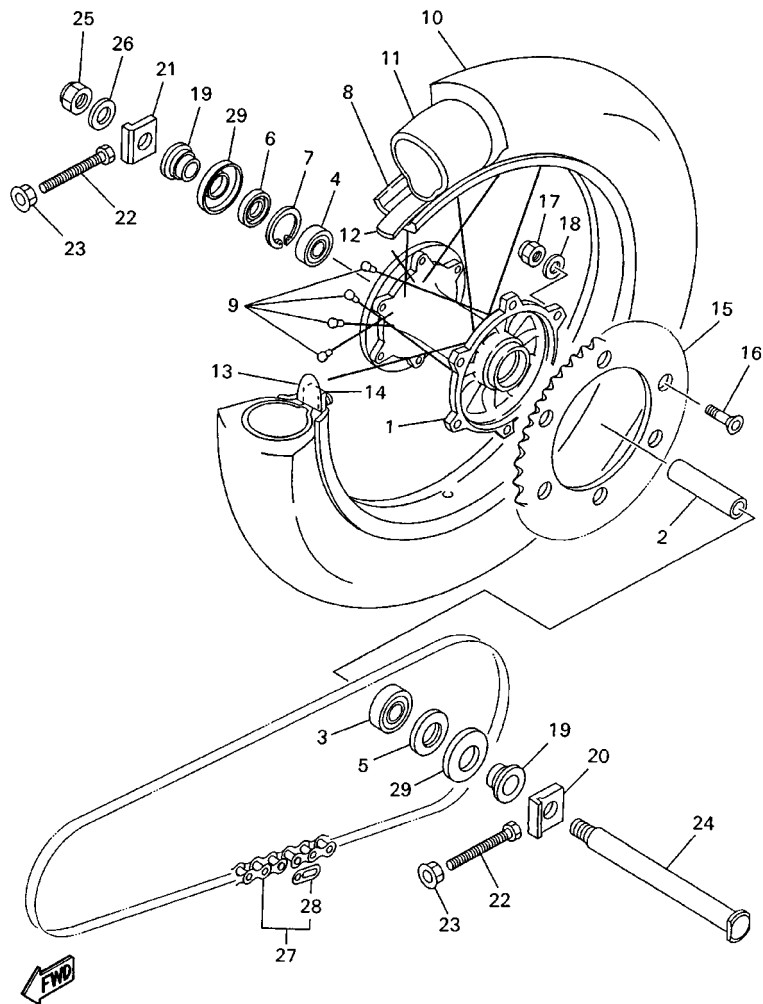
REF. NO.	PART NO.	DESCRIPTION	USA	CAN	OCE	EUR	JPN	REMARKS
1	4XM-2582T-00	DISC, BRAKE	1	1	1	1	1	
2	90149-06327	SCREW	6	6	6	6	6	
3	5DH-2580T-00	CALIPER ASSY (LEFT)	1	1	1	1	1	
4	4EW-W0057-00	.PISTON ASSY, CALIPER	1	1	1	1	1	
5	3JD-W0047-00	..CALIPER SEAL KIT	1	1	1	1	1	
6	5DH-25919-00	.SUPPORT, PAD	1	1	1	1	1	
7	1UY-W0048-50	.BLEED SCREW KIT	1	1	1	1	1	
8	5DH-W0045-00	.BRAKE PAD KIT	1	1	1	1	1	
9	5DH-25933-00	.PIN, PAD	1	1	1	1	1	
10	5DH-25916-00	.PLUG	1	1	1	1	1	
11	90105-08659	BOLT, WASHER BASED	2	2	2	2	2	
12	5DH-2314E-00	COVER, HOSE	1	1	1	1	1	
13	95827-06012	BOLT, FLANGE	1	1	1	1	1	
14	95027-08020	BOLT, FLANGE	1	1	1	1	1	
15	5DH-25875-00	HOLDER, BRAKE HOSE 1	1	1	1	1	1	
16	92907-08200	WASHER	1	1	1	1	1	



5BE100-8290



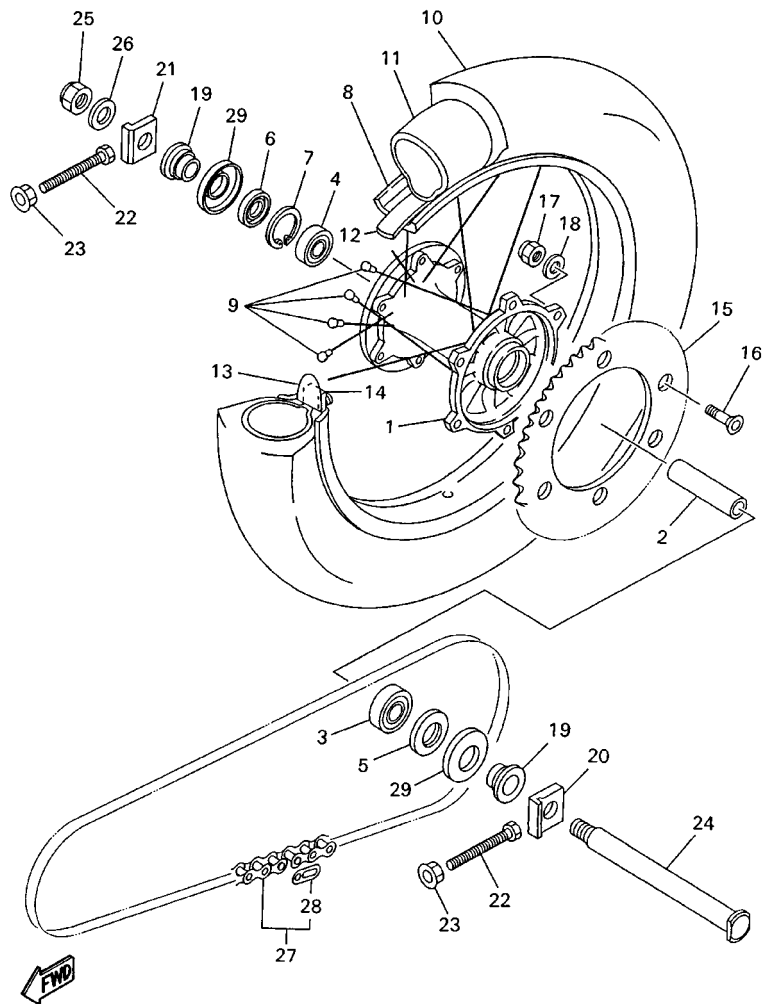
FIG. 30 REAR WHEEL



5GS1100-9300

REF. NO.	PART NO.	DESCRIPTION	USA	CAN	OCE	EUR	JPN	REMARKS
1	5ET-25311-00	HUB, REAR	1	1	1	1	1	
2	5ET-25317-00	SPACER, BEARING	1	1	1	1	1	
3	93306-27205	BEARING	1	1	1	1	1	
4	93306-07202	BEARING	1	1	1	1	1	
5	93106-30044	OIL SEAL	1	1	1	1	1	
6	93106-30045	OIL SEAL	1	1	1	1	1	
7	99009-45500	CIRCLIP	1	1	1	1	1	
8	94421-18610	RIM (2.15-18)	1	1	1	1	1	
9	5GS-25304-00	SPOKE SET, REAR	1	1	1	1	1	
10	94111-18008	TIRE (110/100-18 64M D739)	1	1	1			DUNLOP(FOR ZAF)
*		TIRE (120/90-18)				1	1	LM MICHELIN (FOR OCE)
	94111-1815E	TIRE (110/100-18 64M M60)					1	BRIDGESTONE
11	94212-18188	TUBE (120/90-18)	1	1	1			DUNLOP(FOR ZAF)
*		TUBE (120/90-18)				1	1	LM MICHELIN (FOR OCE)
	94213-18232	TUBE (MC130/80-18)					1	BRIDGESTONE
12	94309-18146	BAND, RIM (110/100-18)	1	1	1			DUNLOP(FOR ZAF)
*		BAND, RIM (2.15-18)				1	1	LM MICHELIN (FOR OCE)
	94340-18086	BAND, RIM (4.00-18)					1	BRIDGESTONE
13	3JE-25394-00	SPACER, BEAD	2	2	2	2	2	
14	4XM-25364-00	DAMPER	2	2	2	2	2	
15	5GS-25450-50	SPROCKET, DRIVEN (50T)	1	1	1	1	1	STD
	5GS-25448-50	SPROCKET, DRIVEN (48T)	1	1	1	1	1	AP
	5GS-25452-50	SPROCKET, DRIVEN (52T)	1	1	1	1	1	AP
16	90109-081G1	BOLT	6	6	6	6	6	
17	90185-08169	NUT, SELF-LOCKING	6	6	6	6	6	
18	90201-08326	WASHER, PLATE	6	6	6	6	6	
19	5ET-25383-00	COLLAR, WHEEL	2	2	2	2	2	

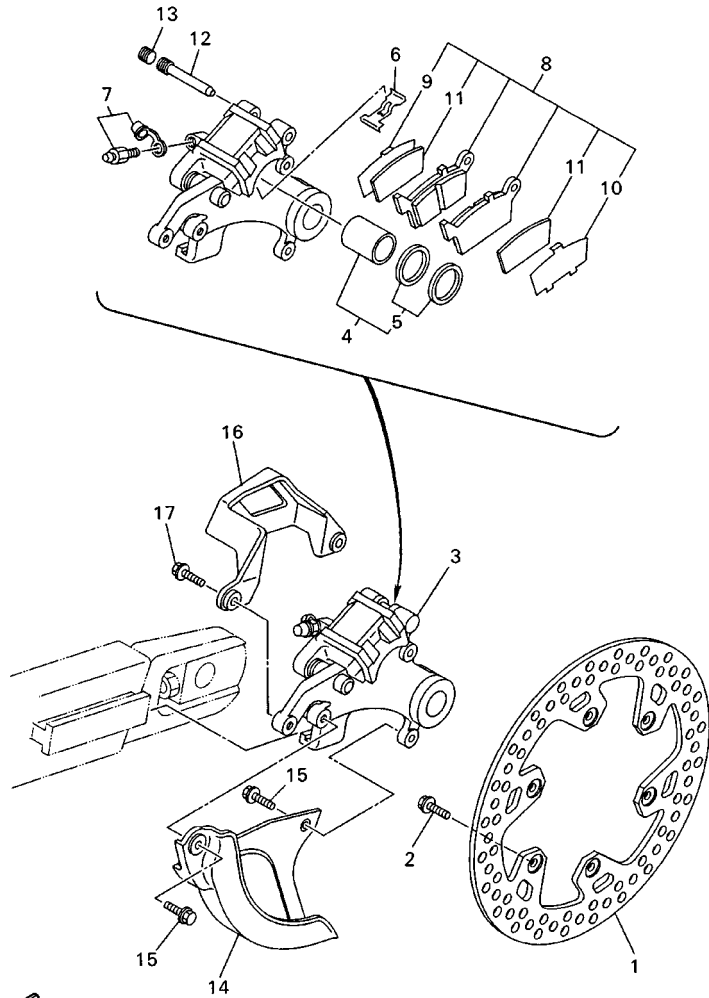
FIG. 30 REAR WHEEL



5GS1100-9300

REF. NO.	PART NO.	DESCRIPTION	USA	CAN	OCE	EUR	JPN	REMARKS
20	5ET-25388-00	PULLER, CHAIN 1	1	1	1	1	1	
21	5ET-25389-00	PULLER, CHAIN 2	1	1	1	1	1	
22	90101-08777	BOLT	2	2	2	2	2	
23	90179-08299	NUT	2	2	2	2	2	
24	5ET-25381-00	AXLE, WHEEL	1	1	1	1	1	
25	90185-20168	NUT, SELF-LOCKING	1	1	1	1	1	
26	90201-203U1	WASHER, PLATE	1	1	1	1	1	
27	9Y581-76113	CHAIN (DID 520VM-114LL)	1	1	1	1	1	
28	94681-76001	JOINT, CHAIN	1	1	1	1	1	
29	5ET-25367-00	COVER, HUB DUST	2	2	2	2	2	

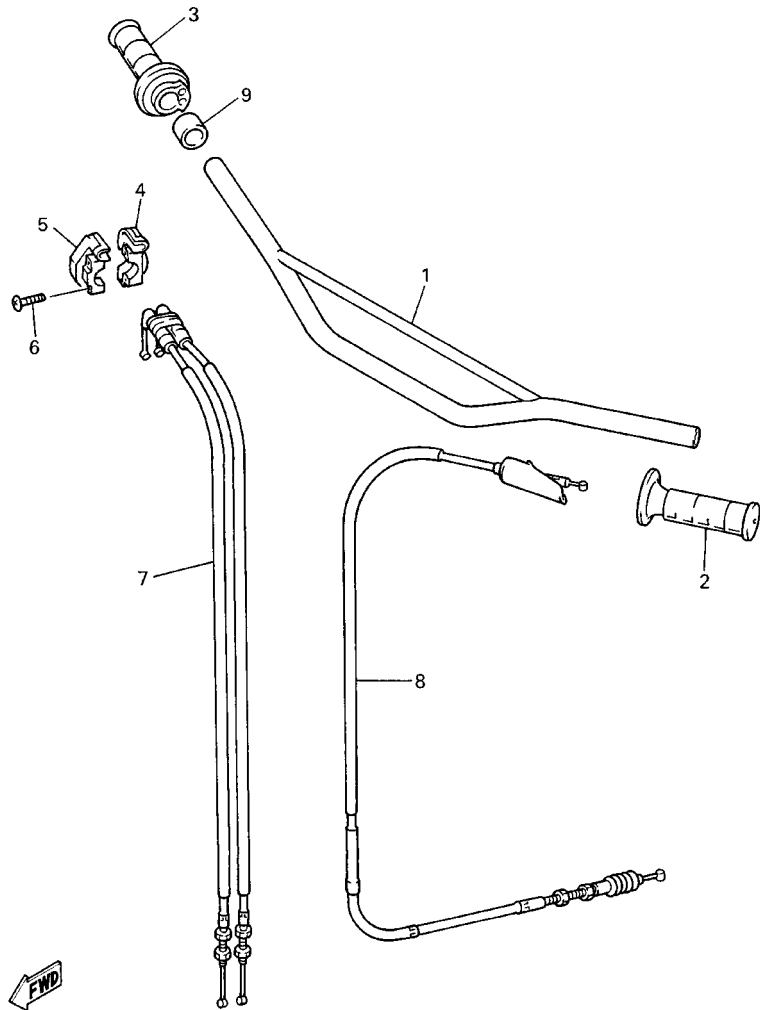
FIG. 31 REAR BRAKE CALIPER



5GS1100-9310

REF. NO.	PART NO.	DESCRIPTION	USA	CAN	OCE	EUR	JPN	REMARKS
1	5DH-2582W-00	DISC, REAR BRAKE 2	1	1	1	1	1	
2	90109-065G4	BOLT	6	6	6	6	6	
3	5GR-2580W-00	CALIPER ASSY, REAR 2	1	1	1	1	1	
4	5ET-W0057-50	.PISTON ASSY, CALIPER	1	1	1	1	1	
5	5ET-W0047-50	..CALIPER SEAL KIT	1	1	1	1	1	
6	5DH-25919-50	..SUPPORT, PAD	1	1	1	1	1	
7	1UY-W0048-50	..BLEED SCREW KIT	1	1	1	1	1	
8	5GR-W0046-00	..BRAKE PAD KIT 2	1	1	1	1	1	
9	5DH-25828-50	..SHIM, CALIPER	1	1	1	1	1	
10	5DH-25827-50	..SHIM, CALIPER	1	1	1	1	1	
11	5GR-22898-50	..INSULATOR, HEAT	2	2	2	2	2	
12	8CR-25924-00	..PIN, PAD	1	1	1	1	1	
13	5DH-25916-00	..PLUG	1	1	1	1	1	
14	5DH-25718-00	PROTECTOR, DISK BRAKE	1	1	1	1	1	
15	95027-06012	BOLT, FLANGE	2	2	2	2	2	
16	4GY-27491-00	PROTECTOR	1	1	1	1	1	
17	95027-06016	BOLT, FLANGE	2	2	2	2	2	

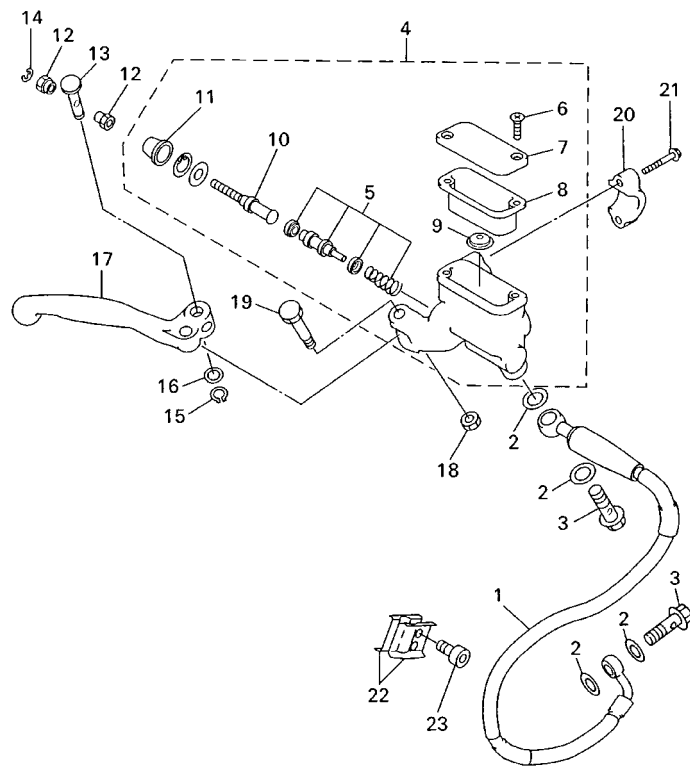
FIG. 32 STEERING HANDLE. CABLE



5BE100-8320

REF. NO.	PART NO.	DESCRIPTION	USA	CAN	OCE	EUR	JPN	REMARKS
1	4XM-26111-00	HANDLEBAR	1	1	1	1	1	
2	4GY-26241-00	GRIP (LEFT)	1	1	1	1	1	
3	5BE-26240-00	GRIP ASSY	1	1	1	1	1	
4	5BE-26281-00	CAP, GRIP UPPER	1	1	1	1	1	
5	5BE-26282-00	CAP, GRIP LOWER	1	1	1	1	1	
6	98507-05020	SCREW, PAN HEAD	2	2	2	2	2	
7	5BE-26302-01	THROTTLE CABLE ASSY	1	1	1	1	1	
8	5BE-26335-01	CABLE, CLUTCH	1	1	1	1	1	
9	90387-225N2	COLLAR	1	1	1	1	1	

FIG. 33 FRONT MASTER CYLINDER

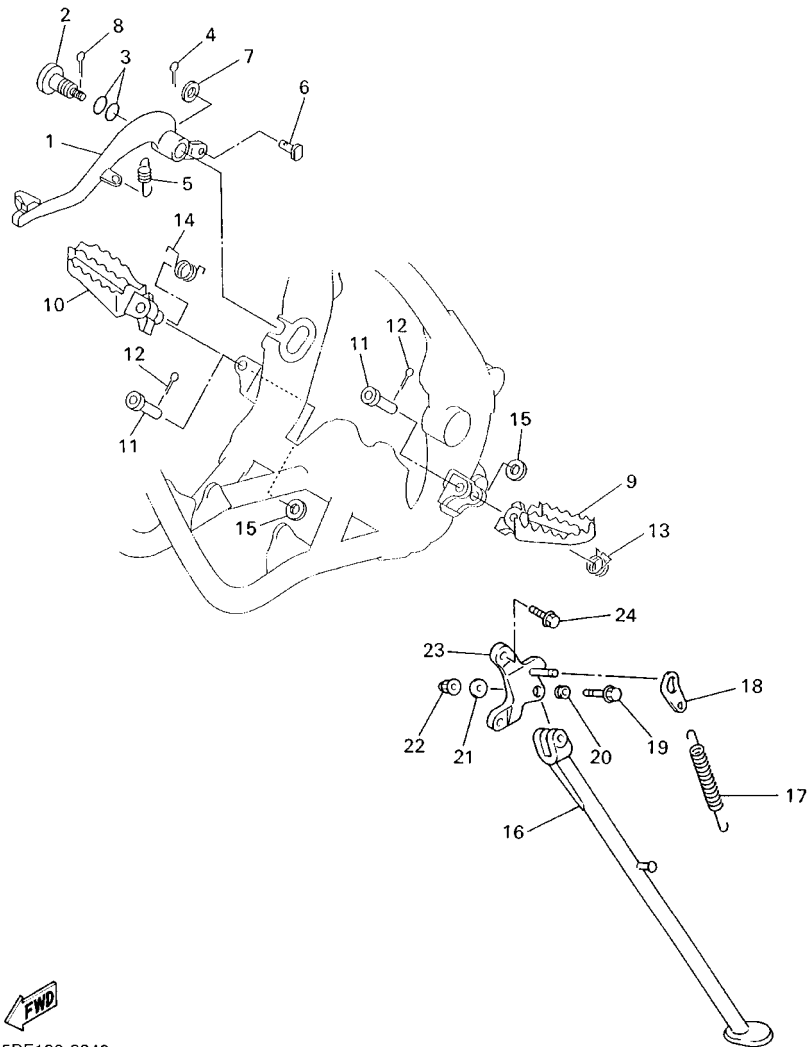


REF. NO.	PART NO.	DESCRIPTION	USA	CAN	OCE	EUR	JPN	REMARKS
1	5GS-25872-00	HOSE, BRAKE 1	1	1	1	1	1	
2	90201-10118	WASHER, PLATE	4	4	4	4	4	
3	90401-10172	BOLT, UNION	2	2	2	2	2	
4	4SS-W2587-00	MASTER CYLINDER SUB ASSY	1	1	1	1	1	
5	4SS-W0041-00	.CYLINDER KIT, MASTER	1	1	1	1	1	
6	98706-04012	.SCREW, FLAT HEAD	2	2	2	2	2	
7	4SS-25852-00	.CAP, RESERVOIR	1	1	1	1	1	
8	4SS-25854-00	.DIAPHRAGM, RESERVOIR	1	1	1	1	1	
9	4SS-25889-00	.SEPARATOR ASSY	1	1	1	1	1	
10	4SS-25880-00	.PUSH ROD COMP.	1	1	1	1	1	
11	4SS-25868-00	.BOOT, MASTER CYLINDER	1	1	1	1	1	
12	4SS-2538E-00	NUT, ADJUSTING	2	2	2	2	2	
13	4SS-83913-00	COLLAR, LEVER 1	1	1	1	1	1	
14	3YX-25866-10	CIRCLIP	1	1	1	1	1	
15	4SS-25866-00	CIRCLIP	1	1	1	1	1	
16	4SS-2583G-00	WASHER	1	1	1	1	1	
17	4SS-83922-01	LEVER 2	1	1	1	1	1	
18	95606-06100	NUT, U	1	1	1	1	1	
19	4SS-2589F-00	BOLT, LEVER	1	1	1	1	1	
20	3YK-25867-00	BRACKET, MASTER CYLINDER	1	1	1	1	1	
21	4SS-25833-00	BOLT, FITTING	2	2	2	2	2	
22	90465-16258	CLAMP	2	2	2	2	2	
23	91317-06014	BOLT	2	2	2	2	2	



5BE100-8330

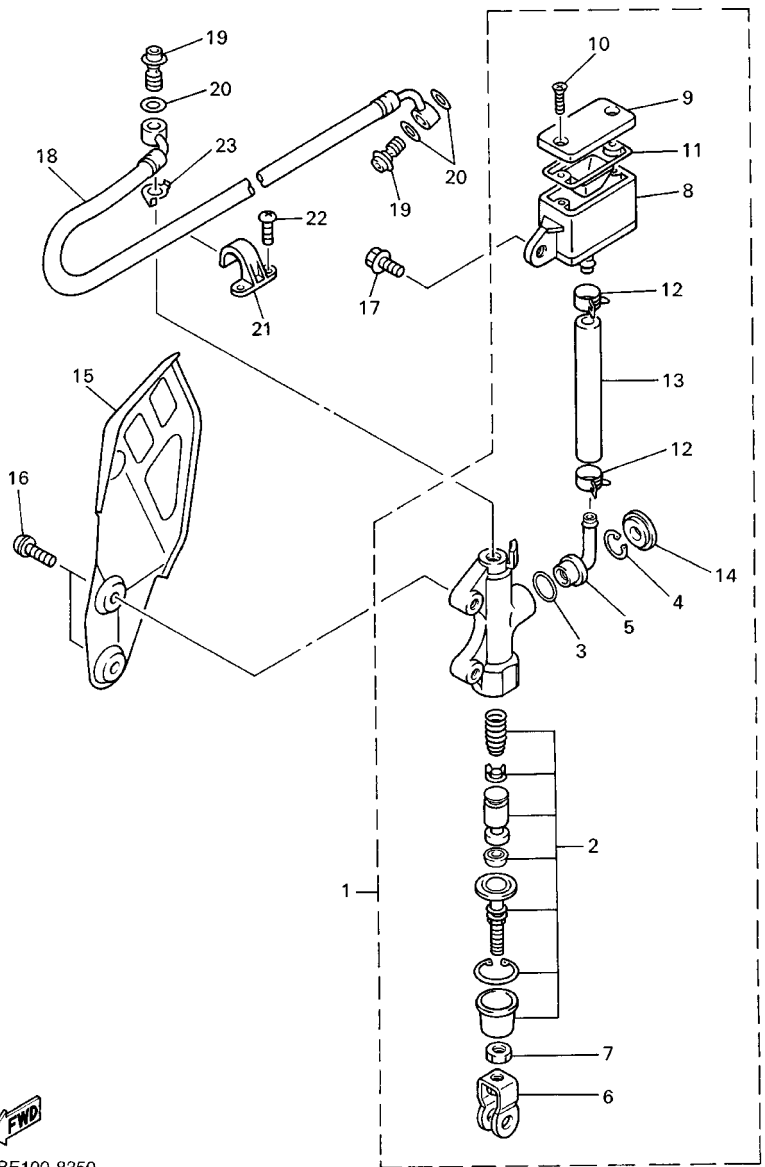
FIG. 34 STAND, FOOTREST



5BF100-8340

REF. NO.	PART NO.	DESCRIPTION	USA	CAN	OCE	EUR	JPN	REMARKS
1	4XM-27200-00	PEDAL, BRAKE	1	1	1	1	1	
2	4SS-27217-00	BOLT	1	1	1	1	1	
3	93210-11073	O-RING	2	2	2	2	2	
4	91401-20012	PIN, COTTER	1	1	1	1	1	
5	90506-16500	SPRING, TENSION	1	1	1	1	1	
6	90240-08120	PIN, CLEVIS	1	1	1	1	1	
7	90201-08089	WASHER, PLATE	1	1	1	1	1	
8	90468-16191	CLIP	1	1	1	1	1	
9	5ET-27411-00	FOOTREST 1	1	1	1	1	1	
10	5ET-27421-00	FOOTREST 2	1	1	1	1	1	
11	90240-10142	PIN, CLEVIS	2	2	2	2	2	
12	91401-25015	PIN, COTTER	2	2	2	2	2	
13	90508-282B8	SPRING, TORSION	1	1	1	1	1	
14	90508-282B9	SPRING, TORSION	1	1	1	1	1	
15	90201-10119	WASHER, PLATE	2	2	2	2	2	
16	5BF-27311-00	STAND, SIDE	1	1	1	1	1	
17	90506-35473	SPRING, TENSION	1	1	1	1	1	
18	5BF-27315-00	LINK, SIDE STAND	1	1	1	1	1	
19	90105-10728	BOLT, WASHER BASED	1	1	1	1	1	
20	90387-1003G	COLLAR	1	1	1	1	1	
21	92990-10200	WASHER, PLAIN	1	1	1	1	1	
22	95617-10100	NUT, U	1	1	1	1	1	
23	5BF-21458-00	BRACKET, SIDE STAND	1	1	1	1	1	
24	95027-10020	BOLT, FLANGE	2	2	2	2	2	

FIG. 35 REAR MASTER CYLINDER



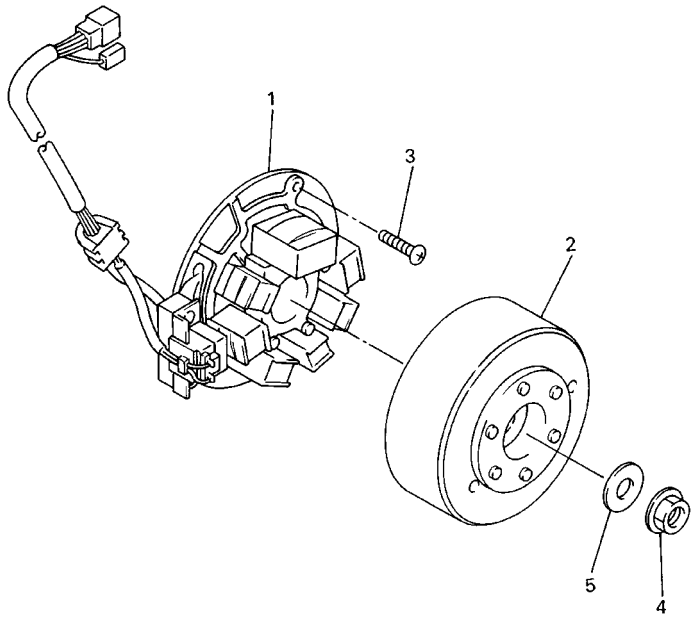
REF. NO.	PART NO.	DESCRIPTION	USA	CAN	OCE	EUR	JPN	REMARKS
1	5BE-2583V-00	RR. MASTER CYLINDER ASSY.	1	1	1	1	1	
2	5BE-W0042-00	.CYLINDER KIT, MASTER	1	1	1	1	1	
3	93210-15620	.O-RING	1	1	1	1	1	
4	2VN-25866-00	.CIRCLIP	1	1	1	1	1	
5	4ML-2582A-50	.JOINT	1	1	1	1	1	
6	3SP-27222-00	.JOINT	1	1	1	1	1	
7	95301-08700	.NUT	2	2	2	2	2	
8	5BE-25894-00	.TANK, RESERVOIR	1	1	1	1	1	
9	5BE-25852-00	.CAP, RESERVOIR	1	1	1	1	1	
10	98706-04040	.SCREW, FLAT HEAD	2	2	2	2	2	
11	56A-25854-00	.DIAPHRAGM, RESERVOIR	1	1	1	1	1	
12	90467-12085	.CLIP	2	2	2	2	2	
13	5BE-25895-00	.HOSE, RESERVOIR	1	1	1	1	1	
14	3FV-2589A-00	.COVER, DUST	1	1	1	1	1	
15	5BE-2117M-00	COVER 2	1	1	1	1	1	
16	92014-06016	BOLT, BUTTON HEAD	2	2	2	2	2	
17	95027-06012	BOLT, FLANGE	1	1	1	1	1	
18	5DH-25873-00	HOSE, BRAKE 2	1	1	1	1	1	
19	90401-10172	BOLT, UNION	2	2	2	2	2	
20	90201-10118	WASHER, PLATE	3	3	3	3	3	
21	2VM-25876-00	HOLDER, BRAKE HOSE 2	2	2	2	2	2	
22	97780-50510	SCREW, TAPPING	4	4	4	4	4	
23	5BE-25844-00	WASHER, LOCK	1	1	1	1	1	



5BE100-8350

FIG. 36 GENERATOR

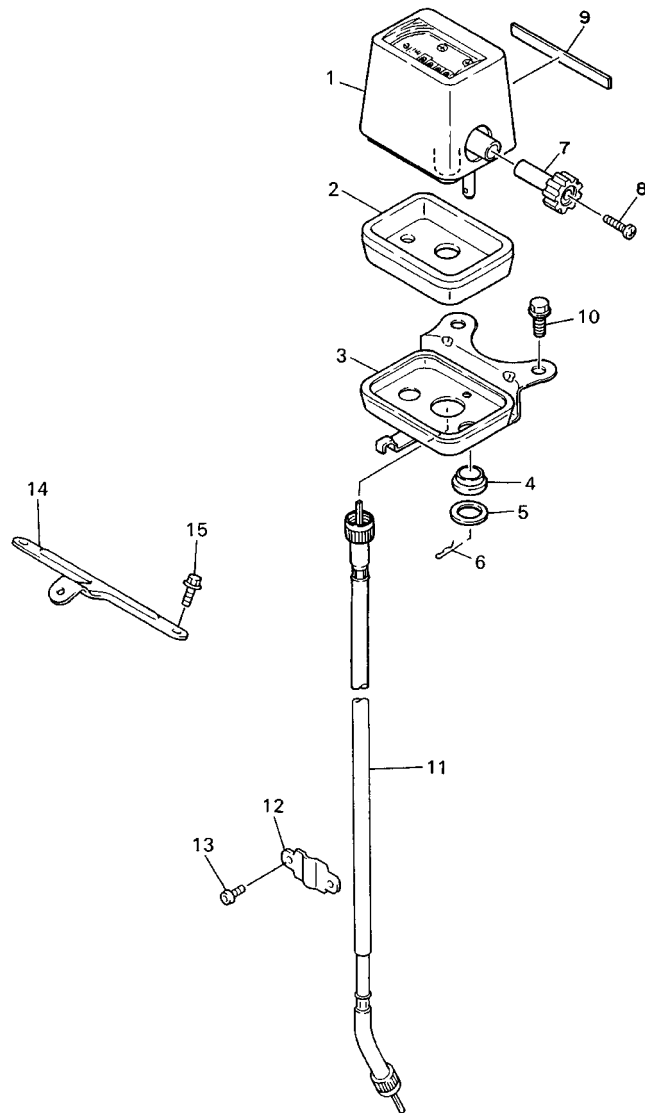
REF. NO.	PART NO.	DESCRIPTION	USA	CAN	OCE	EUR	JPN	REMARKS
1	5BF-85560-00	BASE ASSY	1	1	1	1	1	
2	5BF-85550-00	ROTOR ASSY	1	1	1	1	1	
3	90149-06324	SCREW	3	3	3	3	3	
4	90179-10247	NUT	1	1	1	1	1	
5	90201-101J1	WASHER, PLATE	1	1	1	1	1	



 5BF100-8360



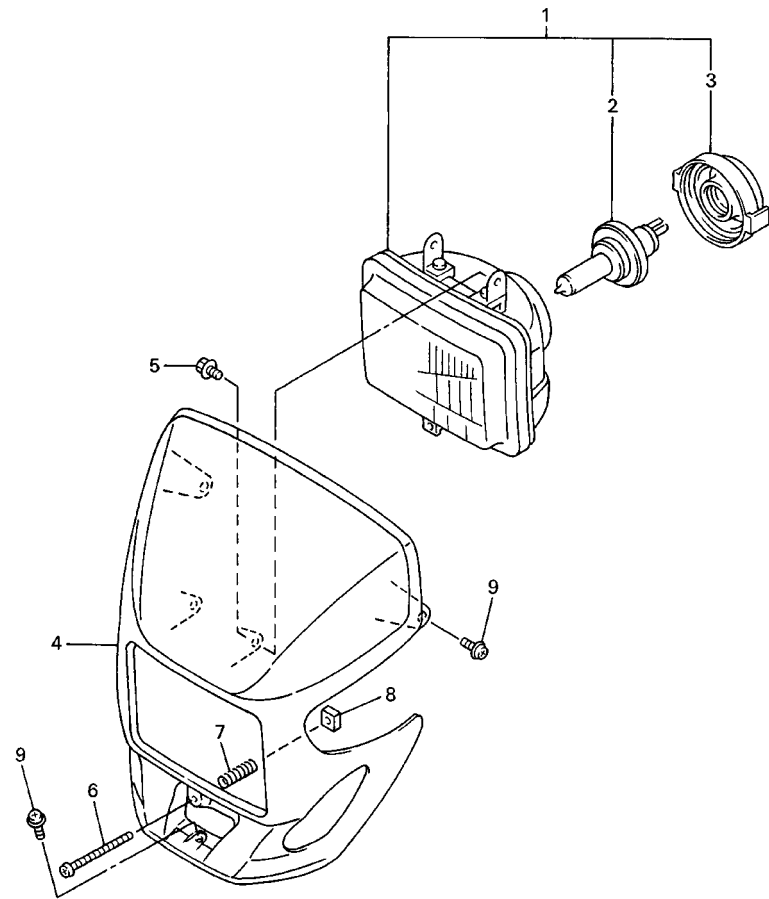
FIG. 37 METER



5BF100-8370

REF. NO.	PART NO.	DESCRIPTION	USA	CAN	OCE	EUR	JPN	REMARKS
1	2HR-83505-G0	TRIP METER COMP.	1			1		MILE(FOR GBR)
	2HR-83505-F0	TRIP METER COMP.		1	1	1	1	KM
2	4V5-83513-00	DAMPER	1	1	1	1	1	
3	2HR-83519-01	BRACKET, METER	1	1	1	1	1	
4	1M1-83526-00	DAMPER 2	2	2	2	2	2	
5	90201-05033	WASHER, PLATE	2	2	2	2	2	
6	437-83525-00	CLIP	2	2	2	2	2	
7	11H-83578-00	KNOB, TRIP METER	1	1	1	1	1	
8	90157-02031	SCREW, PAN HEAD	1	1	1	1	1	
9	2HR-83592-00	DAMPER	1	1	1	1	1	
10	95027-06010	BOLT, FLANGE	2	2	2	2	2	
11	5BF-83550-00	SPEEDOMETER CABLE ASSY	1	1	1	1	1	
12	5BF-2317M-00	STAY 3	1	1	1	1	1	
13	92017-05008	BOLT, BUTTON HEAD	2	2	2	2	2	
14	5BF-84319-00	STAY, HEADLIGHT 2	1	1	1	1	1	
15	95027-06010	BOLT, FLANGE	2	2	2	2	2	

FIG. 38 HEADLIGHT

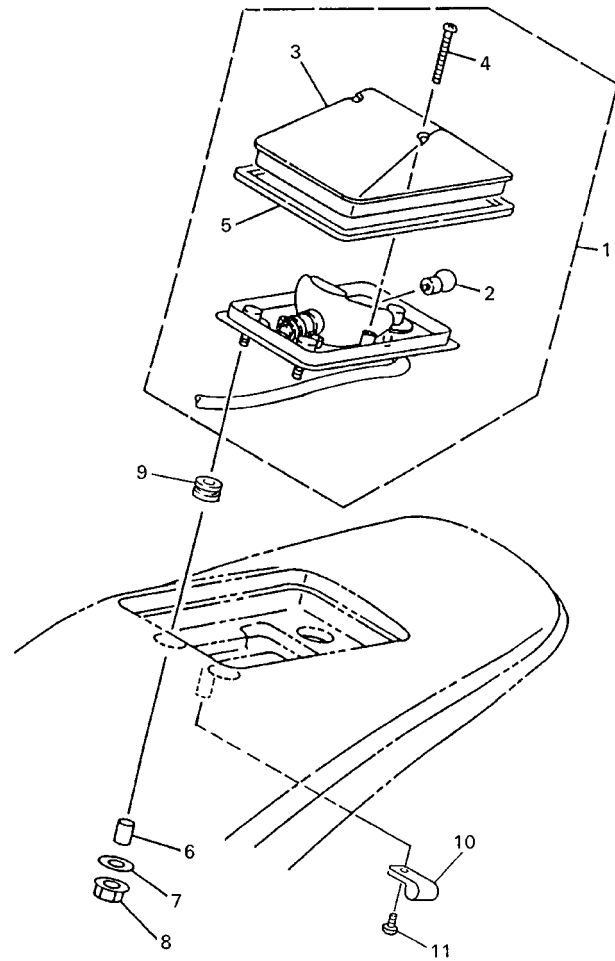


5GS1100-9380

REF. NO.	PART NO.	DESCRIPTION	USA	CAN	OCE	EUR	JPN	REMARKS
1	5BF-84310-00	HEADLIGHT UNIT ASSY	1	1	1	1	1	
2	8G9-84314-00	.BULB (12V-60/55W)	1	1	1	1	1	(H4)HALOGEN
3	5BF-84397-00	.COVER, SOCKET	1	1	1	1	1	
4	5BF-84330-00	BODY ASSY	1	1	1	1	1	
5	55U-84337-00	BOLT, SPECIAL	2	2	2	2	2	
6	5BF-8433E-00	SCREW, ADJUSTING	1	1	1	1	1	
7	5BF-84335-00	SPRING	1	1	1	1	1	
8	5BF-84334-00	NUT, ADJUSTING	1	1	1	1	1	
9	90159-06189	SCREW, WITH WASHER	3	3	3	3	3	

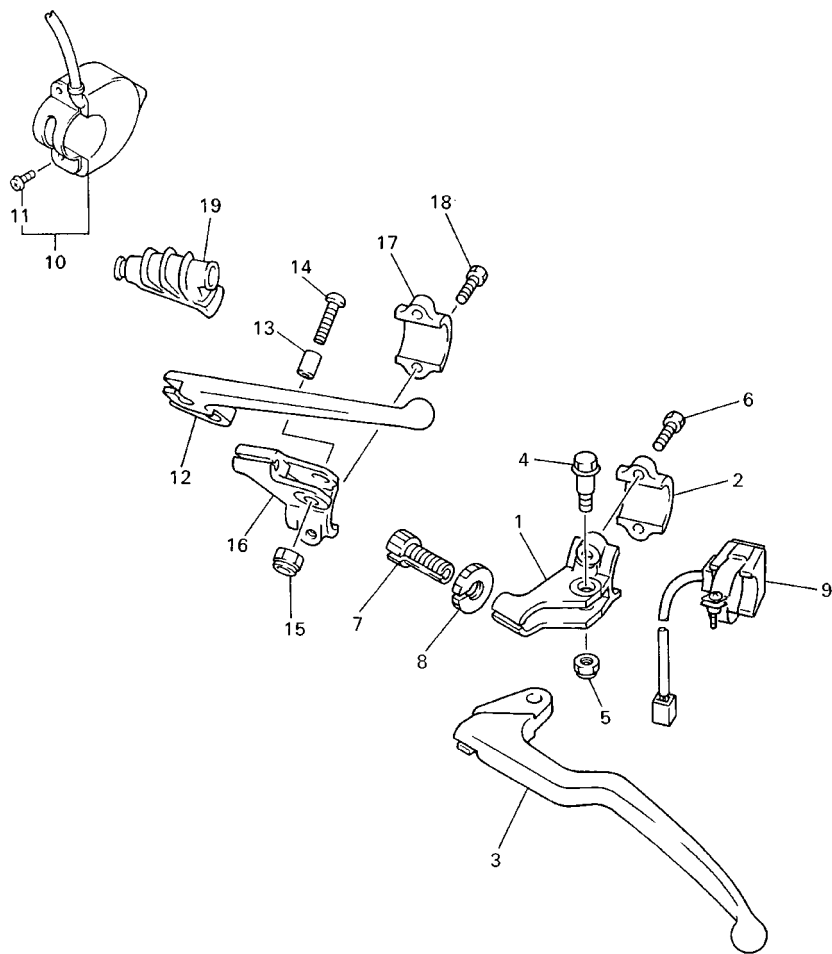
FIG. 39 TAILLIGHT

REF. NO.	PART NO.	DESCRIPTION	USA	CAN	OCE	EUR	JPN	REMARKS
1	5BF-84710-00	TAILLIGHT UNIT ASSY	1	1	1	1	1	
2	36Y-84714-40	.BULB, TAILLIGHT (12V-21/5W)	1	1	1	1	1	
3	4GY-84733-00	.LENS, TAILLIGHT	1	1	1	1	1	
4	97706-40530	.SCREW, TAPPING	2	2	2	2	2	
5	4GY-84723-00	.GASKET, TAIL LENS	1	1	1	1	1	
6	90387-065L5	COLLAR	3	3	3	3	3	
7	90201-06057	WASHER, PLATE	3	3	3	3	3	
8	95707-06500	NUT, FLANGE	3	3	3	3	3	
9	90480-14102	GROMMET	3	3	3	3	3	
10	90461-11099	CLAMP	2	2	2	2	2	
11	97780-40010	SCREW, TAPPING	2	2	2	2	2	



5BF100-8390

FIG. 40 HANDLE SWITCH. LEVER

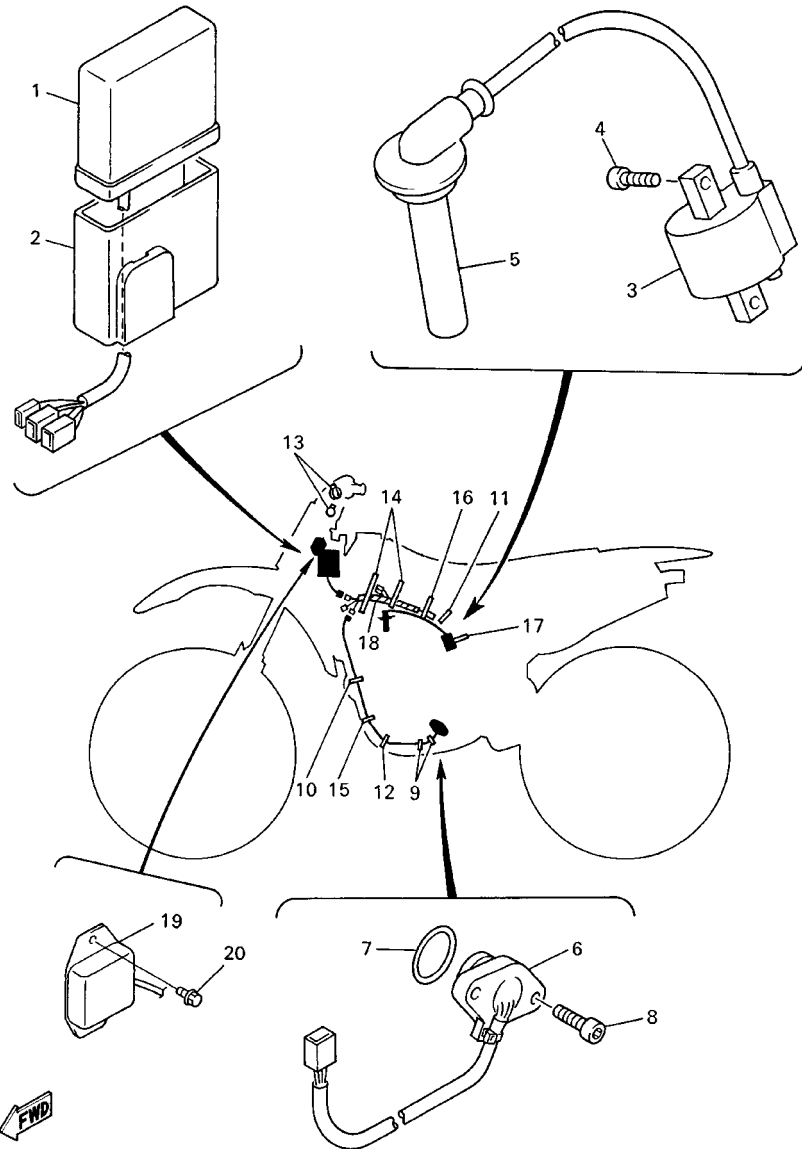


REF. NO.	PART NO.	DESCRIPTION	USA	CAN	OCE	EUR	JPN	REMARKS
1	38V-82911-00	HOLDER, LEVER 1	1	1	1	1	1	
2	38V-82913-00	HOLDER, LEVER LOWER 1	1	1	1	1	1	
3	4GY-83912-00	LEVER 1	1	1	1	1	1	
4	90109-06799	BOLT	1	1	1	1	1	
5	95607-06100	NUT, U	1	1	1	1	1	
6	97007-05016	BOLT	2	2	2	2	2	
7	90123-08090	BOLT	1	1	1	1	1	
8	90179-08401	NUT	1	1	1	1	1	
9	23X-83976-00	SWITCH, HANDLE 1	1	1	1	1	1	
10	5BF-83976-00	SWITCH, HANDLE 1	1	1	1	1	1	
11	98507-04014	.SCREW, PAN HEAD	2	2	2	2	2	
12	583-83981-00	LEVER, DECOMPRESSION	1	1	1	1	1	
13	5BE-83913-00	COLLAR, LEVER 1	1	1	1	1	1	
14	98907-05020	SCREW, BIND	1	1	1	1	1	
15	95607-05100	NUT, U	1	1	1	1	1	
16	5BE-82912-00	HOLDER, LEVER UPPER 1	1	1	1	1	1	
17	38V-82913-00	HOLDER, LEVER LOWER 1	1	1	1	1	1	
18	97007-05016	BOLT	2	2	2	2	2	
19	583-26352-00	COVER, DECOMPRESSION CABLE	1	1	1	1	1	



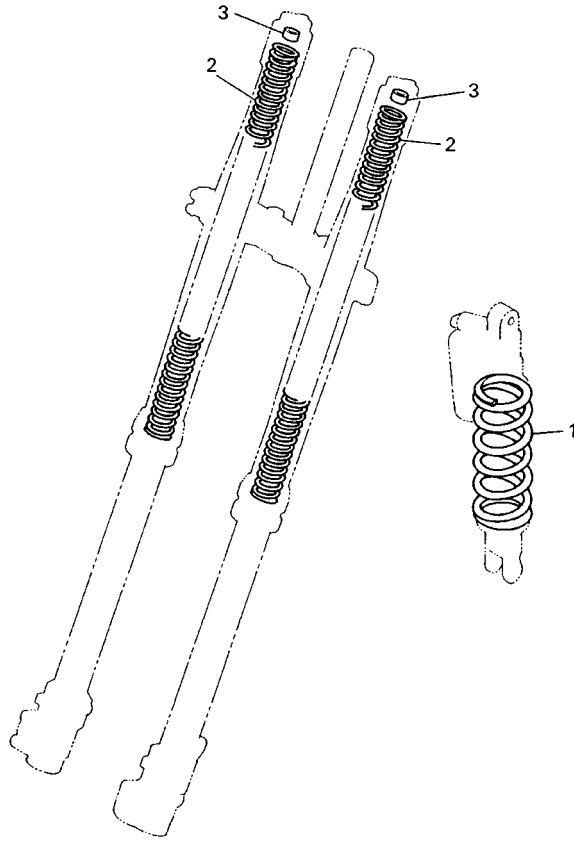
5BF100-8400

FIG. 41 ELECTRICAL 1



REF. NO.	PART NO.	DESCRIPTION	USA	CAN	OCE	EUR	JPN	REMARKS
1	5BF-85540-00	C.D.I. UNIT ASSY	1					
	5BF-85540-10	C.D.I. UNIT ASSY		1	1	1	1	
2	5BE-85546-00	BAND	1	1	1	1	1	
3	5BE-82310-00	IGNITION COIL ASSY	1	1	1	1	1	
4	91317-06016	BOLT	2	2	2	2	2	
5	5BE-82370-00	PLUG CAP ASSY	1	1	1	1	1	
6	5BE-82540-01	NEUTRAL SWITCH ASSY	1	1	1	1	1	
7	93210-21276	O-RING	1	1	1	1	1	
8	90154-05073	SCREW, BINDING	2	2	2	2	2	
9	90464-16061	CLAMP	2	2	2	2	2	
10	90464-13073	CLAMP	1	1	1	1	1	
11	90464-15195	CLAMP	1	1	1	1	1	
12	90460-15126	CLAMP, HOSE	1	1	1	1	1	
13	90464-13077	CLAMP	2	2	2	2	2	
14	90464-15152	CLAMP	2	2	2	2	2	
15	90464-13073	CLAMP	1	1	1	1	1	
16	90465-13275	CLAMP	1	1	1	1	1	
17	90464-15195	CLAMP	1	1	1	1	1	
18	5BF-82509-00	WIRE, SUB LEAD	1					
	5BF-82509-10	WIRE, SUB LEAD		1	1	1	1	
19	82M-81910-A0	VOLTAGE REGULATOR ASSY	1	1	1	1	1	
20	95827-06008	BOLT, FLANGE	2	2	2	2	2	

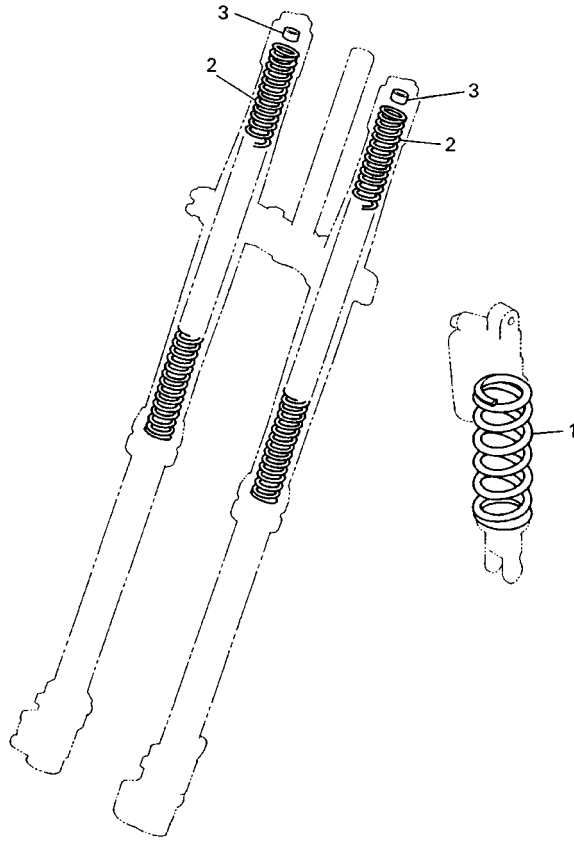
FIG. 42 ALTERNATE (CHASSIS)



REF. NO.	PART NO.	DESCRIPTION	USA	CAN	OCE	EUR	JPN	REMARKS
1	5DH-22212-70	SPRING (K=4.4)	1	1	1	1	1	AP
	5DH-22212-10	SPRING (K=4.6)	1	1	1	1	1	AP
	5DH-22212-20	SPRING (K=4.8)	1	1	1	1	1	AP
	5DH-22212-30	SPRING (K=5.0)	1	1	1	1	1	AP
	5DH-22212-40	SPRING (K=5.2)	1	1	1	1	1	AP
	5DH-22212-50	SPRING (K=5.4)	1	1	1	1	1	AP
	5DH-22212-60	SPRING (K=5.6)	1	1	1	1	1	AP
	5ET-22212-20	SPRING (K=Approx.4.6)	1	1	1	1	1	AP
	5ET-22212-00	SPRING (K=Approx.4.8)	1	1	1	1	1	AP
	5ET-22212-10	SPRING (K=Approx.5.0)	1	1	1	1	1	AP
	5ET-22212-30	SPRING (K=Approx.5.2)	1	1	1	1	1	AP
	5ET-22212-40	SPRING (K=Approx.5.4)	1	1	1	1	1	AP
	5ET-22212-50	SPRING (K=Approx.5.6)	1	1	1	1	1	AP
2	4SS-23141-10	SPRING, FRONT FORK (K=0.38)	2	2	2	2	2	AP
	4SS-23141-20	SPRING, FRONT FORK (K=0.39)	2	2	2	2	2	AP
	4SS-23141-30	SPRING, FRONT FORK (K=0.40)	2	2	2	2	2	AP
	4SS-23141-40	SPRING, FRONT FORK (K=0.41)	2	2	2	2	2	AP
	4SS-23141-50	SPRING, FRONT FORK (K=0.42)	2	2	2	2	2	AP
	4SS-23141-60	SPRING, FRONT FORK (K=0.43)	2	2	2	2	2	AP
	4SS-23141-70	SPRING, FRONT FORK (K=0.44)	2	2	2	2	2	AP
	5BE-23141-L0	SPRING, FRONT FORK (K=0.45)	2	2	2	2	2	AP
	5BE-23141-00	SPRING, FRONT FORK (K=0.46)	2	2	2	2	2	AP
	5GR-23141-00	SPRING, FRONT FORK (K=0.47)	2	2	2	2	2	AP
	5ET-23141-20	SPRING (K=Approx.0.40)	2	2	2	2	2	AP
	5ET-23141-00	SPRING (K=Approx.0.41)	2	2	2	2	2	AP
	5ET-23141-30	SPRING (K=Approx.0.42)	2	2	2	2	2	AP
	5ET-23141-10	SPRING (K=Approx.0.43)	2	2	2	2	2	AP

 5BE100-8390

FIG. 42 ALTERNATE (CHASSIS)



REF. NO.	PART NO.	DESCRIPTION	USA	CAN	OCE	EUR	JPN	REMARKS
2	5ET-23141-40	SPRING (K=Approx.0.44)	2	2	2	2	2	AP
3	4SS-23364-L0	COLLAR 2	1	1	1	1	1	UN


  
 5BE100-8390

NUMERICAL INDEX

PART NO.	GRID NO.	PART NO.	GRID NO.	PART NO.	GRID NO.	PART NO.	GRID NO.	PART NO.	GRID NO.	PART NO.	GRID NO.
4SS-W0041-00	E - 8	3FV-12153-10	B - 6	5BE-12577-00	B - 9	5BF-14409-00	B - 13	5BF-14916-D1	B - 15	3TJ-14984-40	C - 3
5BE-W0042-00	E - 10	3FV-12153-20	B - 6	5BE-12578-00	B - 9	5BE-1441A-00	B - 14	5GS-14916-DJ	B - 15	5BE-14985-00	C - 3
5DH-W0045-00	E - 3	3LD-12168-A0	B - 5	5BE-12579-00	B - 9	5BF-1441A-00	B - 13	5GS-14916-DK	B - 15	5BE-14987-00	C - 4
5GR-W0046-00	E - 6	3LD-12168-F0	B - 5	583-13113-00	C - 8	5BE-1441E-00	B - 14	5GS-14916-DL	B - 15	4FN-14997-00	B - 15
3JD-W0047-00	E - 3	3LD-12168-H1	B - 5	5BE-13161-01	B - 12	5BE-14417-00	B - 14	5GS-14916-DM	B - 15	5BE-15150-02	C - 7
5ET-W0047-50	E - 6	3LD-12168-K1	B - 5	5BE-13171-00	B - 12	5BF-1443E-00	B - 14	5BF-14916-DN	B - 15	5BE-15362-00	D - 2
1UY-W0048-50	E - 3	3LD-12168-M1	B - 5	5BE-13300-00	B - 10	5BF-14437-00	B - 13	5GS-14916-DP	B - 15	4JT-15381-01	C - 7
	E - 6	3LD-12168-R1	B - 5	1HX-13310-00	B - 10	5BE-14449-00	C - 4	5GS-14916-D1	C - 2	5BE-15383-00	C - 7
4EW-W0057-00	E - 3	3LD-12168-U1	B - 5	5BE-13341-00	B - 10	4XM-14451-00	B - 13	5BF-14919-00	C - 5	5BE-15411-00	C - 8
5ET-W0057-50	E - 6	3LD-12168-W1	B - 5	5BE-13342-00	B - 10	5BF-14452-00	B - 13	5BE-14922-01	C - 3	5BE-15415-00	C - 8
4SS-W2587-00	E - 8	3LD-12168-Y1	B - 5	5BE-13411-00	B - 10	5BE-14453-00	B - 13	3TJ-14933-40	C - 3	5BE-15421-00	C - 7
5BE-11102-10	B - 2	3LD-12168-00	B - 5	5BE-13412-00	B - 10	5BF-14457-00	B - 13	5BF-14933-00	C - 4	5BE-15431-00	C - 8
4KG-1111G-00	B - 2	3LD-12168-20	B - 5	5BE-13416-00	B - 10	5BE-14458-00	B - 13	4FN-14934-00	C - 4	5BE-15441-00	C - 7
5BE-11133-10	B - 2	3LD-12168-40	B - 5	1UY-13440-02	B - 12	3JD-14459-01	B - 13	5BE-14937-00	C - 4	5BE-15451-00	C - 8
5BE-11134-10	B - 2	3LD-12168-60	B - 5	3LD-13447-00	B - 12	3JD-14477-00	B - 13	5BF-14937-00	C - 5	5BE-15453-00	C - 8
5BE-11166-00	B - 2	3LD-12168-80	B - 5	5BE-13464-00	B - 10	5BF-14493-00	B - 13	3TJ-1494F-11	C - 2	5BE-15462-00	C - 8
371-11167-01	B - 2	3LD-12169-E0	B - 6	5BE-13465-00	B - 10	3TJ-14496-40	B - 15	3TJ-1494F-12	C - 2	5GR-15601-00	C - 9
5BE-11167-00	B - 2	3LD-12169-G0	B - 6	5BE-13582-00	B - 2	5BE-14521-00	C - 2	3TJ-1494F-18	C - 2	5BE-15620-02	C - 9
5GR-11181-00	B - 2	3LD-12169-J0	B - 6	5BE-13597-01	B - 13	3TJ-14522-40	B - 15	3TJ-1494F-19	C - 2	3SP-15621-02	C - 9
5BE-11191-00	B - 2	3LD-12169-L0	B - 6	5GS-14101-00	B - 15	5BE-14535-00	C - 4	3TJ-1494F-20	C - 2	5BE-15651-00	C - 9
5BE-11193-00	B - 3	3LD-12169-N0	B - 6	5GS-14101-10	B - 15	3TJ-14536-40	C - 3	3TJ-1494F-21	C - 2	5GR-15664-00	C - 9
5BE-11311-10	B - 3	3LD-12169-T0	B - 6	3TJ-14105-40	C - 3	4FN-14546-00	B - 15	3TJ-1494F-22	C - 2	5BE-15668-00	C - 9
5BF-11351-00	B - 3	3LD-12169-11	B - 5	5BE-14107-00	C - 3	676-14548-00	C - 3	3TJ-1494F-23	C - 3	5BE-15674-00	C - 9
5GR-11400-00	B - 4	3LD-12169-31	B - 6	5BE-14115-00	C - 4	5BE-14557-00	C - 3	5BE-14940-17	C - 3	5BE-15686-01	C - 9
5GR-11412-00	B - 4	3LD-12169-50	B - 6	3TJ-14137-40	C - 4	4FN-14561-00	B - 13	5BE-14940-18	C - 3	5BE-16111-00	C - 10
5GR-11422-00	B - 4	3LD-12169-70	B - 6	5BE-14137-00	C - 4	5BE-14561-00	C - 4	5BE-14940-19	C - 3	5BE-16150-00	C - 10
5BE-11454-00	B - 4	3LD-12169-90	B - 6	5BE-14146-00	C - 4	6H4-14561-00	C - 3	5BF-14940-00	C - 4	2JN-16154-00	C - 10
5BE-11455-00	B - 4	5BF-12170-00	B - 7	5BE-14148-00	C - 4	5BE-14562-00	C - 4	3TJ-14943-47	C - 2	5BE-16321-00	C - 10
5BE-11531-00	B - 4	5BF-12180-00	B - 7	3TJ-14159-40	C - 2	688-14592-00	C - 3	4MX-14943-39	C - 2	360-16325-00	C - 10
5BE-11536-00	B - 4	5BE-12210-00	B - 7	5BE-14162-00	C - 3	5BE-14596-00	C - 4	4MX-14943-40	C - 2	5BE-16331-00	C - 10
5BE-11603-00	B - 4	4FM-12213-00	B - 7	5BE-14171-00	C - 3	5BE-14611-00	C - 6	4MX-14943-41	C - 2	3YF-16351-00	C - 10
5GR-11631-00	B - 4	5BE-12241-00	B - 7	5BE-14197-00	C - 4	3VD-14613-00	C - 6	4MX-14943-42	C - 2	5BE-16356-00	C - 10
5GR-11633-00	B - 4	5BE-12251-00	B - 7	5BE-14216-00	C - 3	5BE-14628-00	C - 6	4MX-14943-43	C - 2	5BE-16357-00	C - 10
5BE-11651-00	B - 4	5BE-12252-00	B - 7	5BE-14265-00	C - 4	5BF-14710-00	C - 6	4MX-14943-89	C - 2	2JN-16371-00	C - 10
5BE-11681-00	B - 4	5BE-12280-10	B - 7	3TJ-14267-40	B - 15	5BF-14710-10	C - 6	4MX-14943-90	C - 2	5BE-16381-00	C - 10
5BE-12111-00	B - 5	5BE-12283-00	B - 7	3TJ-14293-40	C - 3	3GW-14714-00	C - 6	4MX-14943-91	C - 2	4JT-16384-00	C - 10
5BE-12112-00	B - 5	5BE-12292-00	B - 7	5BE-14293-00	B - 13	4BD-14766-00	C - 6	4MX-14943-92	C - 2	5BF-17121-00	C - 11
5BE-12113-00	B - 5	5BF-1240A-00	B - 9	5GR-14340-00	B - 14	5BE-14788-00	C - 6	4MX-14943-93	C - 2	5BF-17131-00	C - 11
5GR-12114-00	B - 5	5BE-12422-10	B - 8	5BE-14346-00	C - 4	5BF-14854-00	C - 4	7A9-14943-11	C - 3	5BF-17141-00	C - 11
4GY-12117-00	B - 5	5BF-12439-00	B - 8	5BF-14347-23	C - 5	5BF-14871-00	C - 4	7A9-14943-17	C - 3	5BF-17151-00	C - 11
5BE-12117-00	B - 5	5DJ-12451-00	B - 8	5BF-14347-27	C - 5	5BF-14872-00	C - 4	5BE-14947-00	C - 2	5BF-17211-00	C - 11
1AA-12118-00	B - 5	5GR-12458-00	B - 8	5BF-14349-00	B - 14	5BF-14873-00	C - 4	3TJ-14948-03	C - 2	5BF-17221-00	C - 11
1WG-12118-00	B - 5	5BF-12461-00	B - 9	3TJ-14365-40	C - 3	5BF-14916-DJ	B - 15	3TJ-14948-04	C - 2	5BF-17231-00	C - 11
33M-12119-00	B - 5	22W-12462-00	B - 9	5BE-14379-01	C - 3	5BF-14916-DK	B - 15	3TJ-14948-05	C - 2	5BF-17241-00	C - 11
4SV-12119-00	B - 5	5BE-12481-00	B - 9	5BE-14388-00	B - 15	5BF-14916-DL	B - 15	3TJ-14948-06	C - 2	5BF-17251-00	C - 11
5BE-12121-00	B - 5	5BE-12482-00	B - 9	3TJ-14393-40	B - 15	5BF-14916-DM	B - 15	3TJ-14948-07	C - 2	5BF-17411-00	C - 11
3GM-12126-00	B - 5	5BE-12564-00	B - 8	5BF-1440F-00	B - 13	5BF-14916-DN	B - 15	5BE-14959-00	B - 15	5BE-17421-00	C - 11
3FV-12153-00	B - 6	5BE-12576-00	B - 9	5BE-14401-00	B - 13	5BF-14916-DP	B - 15	5BE-14968-00	C - 3	5BE-17466-10	C - 7



NUMERICAL INDEX

PART NO.	GRID NO.	PART NO.	GRID NO.	PART NO.	GRID NO.	PART NO.	GRID NO.	PART NO.	GRID NO.	PART NO.	GRID NO.
4L0-17471-00	C - 7	4XM-22128-00	D - 6	5GS-23103-L0	D - 11	4SS-23153-L0	D - 12	5GS-24731-00	D - 15	4SS-25889-00	E - 8
5GR-17471-00	C - 12	5DH-22141-00	D - 6	5GS-23103-M0	D - 11	4SS-23158-L0	D - 11	4DA-25104-00	E - 2	3FV-2589A-00	E - 10
3XK-18101-02	C - 14	4EW-22151-20	D - 6	5BF-23110-L0	D - 12	5BF-25111-00	D - 12	5BF-25111-00	E - 2	4SS-2589F-00	E - 8
5BE-18110-00	C - 14	5ET-22156-00	D - 6	5DH-23111-L0	D - 11	5EN-2316A-L0	D - 11	5DH-25117-00	E - 2	5BE-25894-00	E - 10
3XK-18122-00	C - 14	5ET-2217A-00	D - 6		D - 12		D - 12	5BE-25181-00	E - 2	5BE-25895-00	E - 10
3XK-18140-00	C - 13	5DH-2217F-00	D - 7	5DH-23118-L0	D - 11	5GS-2316A-L0	D - 11	5DH-25183-00	E - 2	5DH-25916-00	E - 3
5BE-18172-00	C - 14	3JD-22178-10	C - 15		D - 12		D - 12	5BF-25190-00	E - 2		E - 6
3XJ-18173-00	C - 14	4EW-22178-00	C - 15	3JD-2312G-L0	D - 11	5BF-2317M-00	E - 12	5GS-25304-00	E - 4	5DH-25919-00	E - 3
3XJ-18178-00	C - 14	4XM-22199-00	D - 6		D - 12	5GR-23170-L0	D - 11	5ET-25311-00	E - 4	5DH-25919-50	E - 6
3XJ-18182-00	C - 14	5GS-22201-00	D - 8	5DH-23120-L0	D - 11		D - 12	5ET-25317-00	E - 4	8CR-25924-00	E - 6
3XJ-18184-00	C - 14	5GS-22201-10	D - 8	5ET-23125-L0	D - 11	5GS-23170-L0	D - 11	5ET-25317-00	E - 4	5DH-25933-00	E - 3
4EW-18185-00	C - 14	5GS-22201-20	D - 8		D - 12		D - 12	4XM-25364-00	E - 4	4XM-26111-00	E - 7
5BE-18501-00	C - 13	5GS-22201-30	D - 8	5ET-23136-L0	D - 11	5ET-23171-L0	D - 11	4SS-2538E-00	E - 8	5BE-26240-00	E - 7
5BE-18502-00	C - 13	5GS-22201-40	D - 8	5DH-2314E-00	E - 3		D - 12	5ET-25381-00	E - 5	4GY-26241-00	E - 7
5BE-18503-00	C - 13	5GS-22210-00	D - 8	5DH-2314F-L0	D - 12	5DH-23183-00	D - 8	5ET-25383-00	E - 4	5BE-26281-00	E - 7
5BE-18541-00	C - 13	5GS-22210-10	D - 8	4SS-2314G-L0	D - 12	509-23184-L0	D - 8	5ET-25388-00	E - 5	5BE-26282-00	E - 7
4BA-18542-00	C - 13	5GS-22210-20	D - 8	5DH-2314H-00	D - 13	5DH-23195-L0	D - 11	5ET-25389-00	E - 5	5BE-26302-01	E - 7
5DH-18562-00	C - 7	5GS-22210-30	D - 8	5BF-2314J-00	D - 12		D - 12	2J5-25394-01	E - 2	5BE-26335-01	E - 7
5GS-21101-00-P0	C - 15	5GS-22210-40	D - 8	4SR-23141-L0	D - 11	4EW-2331E-L0	D - 13	3JE-25394-00	E - 4	583-26352-00	E - 15
5BE-2117M-00	E - 10	5DH-22212-10	F - 3		D - 12	5BF-23340-L0	D - 12	5GS-25448-50	E - 4	4XM-27200-00	E - 9
5BF-21190-00-P0	C - 15	5DH-22212-20	D - 8	4SS-23141-10	F - 3	4SS-23346-L0	D - 12	5GS-25450-50	E - 4	4SS-27217-00	E - 9
1HX-2135F-10	D - 7		F - 3	4SS-23141-20	F - 3	3SP-23356-L0	D - 13	5GS-25452-50	E - 4	3SP-27222-00	E - 10
5BE-21417-00	D - 2	5DH-22212-30	D - 8	4SS-23141-30	F - 3	4SS-23364-L0	F - 4	5DH-25718-00	E - 6	5BF-27311-00	E - 9
5BE-21425-00	C - 15		F - 3	4SS-23141-40	F - 3	4DA-23389-00	D - 10	5DH-2582T-00	E - 3	5BF-27315-00	E - 9
5GR-21425-00	C - 15	5DH-22212-40	F - 3	4SS-23141-50	F - 3	4GY-23389-00	D - 10	5GR-2580W-00	E - 6	5ET-27411-00	E - 9
5BF-21458-00	E - 9	5DH-22212-50	F - 3	4SS-23141-60	F - 3	5ET-23393-L0	D - 11	4ML-2582A-50	E - 10	5ET-27421-00	E - 9
5BE-2147A-00	D - 2	5DH-22212-60	F - 3	4SS-23141-70	F - 3		D - 12	4XM-2582T-00	E - 3	4GY-27491-00	E - 6
5BE-21471-00	D - 2	5DH-22212-70	F - 3	5BE-23141-L0	F - 3	4EW-23416-00	D - 10	5DH-2582W-00	E - 6	5BE-2814F-00	D - 2
4DA-21511-20	D - 3	5ET-22212-00	F - 3	5BE-23141-00	F - 3	5BF-23435-00	D - 10	5DH-25827-50	E - 6	5ET-28166-00	D - 2
3FY-21575-01	D - 4	5ET-22212-10	F - 3	5ET-23141-00	F - 3	3SP-23441-00	D - 10	5DH-25828-50	E - 6	4GY-2831V-00	D - 10
5BF-21611-00	D - 3	5ET-22212-20	F - 3	5ET-23141-10	F - 3	5GS-24110-00	D - 14	4SS-2583G-00	E - 8	4GY-2832V-00	D - 10
5GS-2163G-00	D - 3	5ET-22212-30	F - 3	5ET-23141-20	F - 3	4EW-2412F-00	D - 14	5BE-2583V-00	E - 10	82M-81910-A0	F - 2
5BE-21642-00	D - 3	5ET-22212-40	F - 3	5ET-23141-30	F - 3	24X-24144-00	D - 14	4SS-25833-00	E - 8	5BE-82310-00	F - 2
5BF-21711-00	D - 4	5ET-22212-50	F - 3	5ET-23141-40	F - 4	3SP-24173-00	D - 14	5BE-25844-00	E - 10	5BE-82370-00	F - 2
5BF-2172A-00	D - 4	3SP-22213-00	D - 8	5GR-23141-L0	D - 11	22W-24181-00	C - 6	4SS-25852-00	E - 8	5BF-82509-00	F - 2
5BF-21721-00	D - 4	5DH-22214-00	D - 8		D - 12	3GD-24181-00	B - 9	5BE-25852-00	E - 10	5BF-82509-10	F - 2
5GS-2173E-00	D - 4	5DH-22224-00	D - 8	5GR-23141-00	F - 3	4SS-24181-00	D - 14	4SS-25854-00	E - 8	5BE-82540-01	F - 2
5GS-2173F-00	D - 4	4JX-22226-00	D - 8	5DH-23142-L0	D - 11	5BE-24182-00	D - 14	56A-25854-00	E - 10	38V-82911-00	E - 15
5BE-21731-10	D - 4	3SP-22234-00	D - 8		D - 12	3JD-24186-00	D - 14	2VN-25866-00	E - 10	5BE-82912-00	E - 15
5BF-2174A-00	D - 4	4EW-22253-00	D - 8	4SS-23144-L0	D - 11	5GS-24240-00	D - 14	3YX-25866-10	E - 8	38V-82913-00	E - 15
5BE-21741-10	D - 4	5DH-22253-00	D - 8		D - 12	3XJ-24380-00	D - 14	4SS-25866-00	E - 8	2HR-83505-F0	E - 12
3JD-21748-00	D - 3	5ET-22355-00	D - 6	5ET-23145-L0	D - 11	2GU-24500-01	D - 14	3YK-25867-00	E - 8	2HR-83505-G0	E - 12
5BE-21756-00	C - 15	3V6-22358-00	D - 14		D - 12	4X8-24512-00	D - 14	4SS-25868-00	E - 8	4V5-83513-00	E - 12
5BF-21823-00	D - 4	4EW-22474-00	D - 8	4SS-23146-L0	D - 11	3AJ-24523-00	D - 14	5GS-25872-00	E - 8	2HR-83519-01	E - 12
5GS-21871-00	D - 4	3JE-22475-00	D - 8		D - 12	3AJ-24534-00	D - 14	5DH-25873-00	E - 10	437-83525-00	E - 12
26H-21874-00	D - 4	5GR-22898-50	E - 6	5DH-23149-L0	D - 11	1UY-24610-00	D - 14	5DH-25875-00	E - 3	1M1-83526-00	E - 12
26H-21875-00	D - 4	5GS-23102-L0	D - 11		D - 12	5GS-24710-00	D - 15	2VM-25876-00	E - 10	5BF-83550-00	E - 12
5CU-22110-00	D - 6	5GS-23102-M0	D - 11	4SS-23153-L0	D - 11	5BE-24728-00	D - 15	4SS-25880-00	E - 8	11H-83578-00	E - 12

NUMERICAL INDEX

PART NO.	GRID NO.	PART NO.	GRID NO.	PART NO.	GRID NO.	PART NO.	GRID NO.	PART NO.	GRID NO.	PART NO.	GRID NO.
2HR-83592-00	E - 12	90109-065G4	E - 6	90185-08169	C - 15	90240-10142	E - 9	90460-61162	B - 13	91316-04012	B - 15
4GY-83912-00	E - 15	90109-066F0	B - 2		E - 4	90267-32070	B - 13	90461-10136	C - 7	91317-05014	B - 13
4SS-83913-00	E - 8	90109-06799	E - 15	90185-14112	D - 7	90280-03045	B - 4	90461-11099	E - 14	91317-06014	E - 8
5BE-83913-00	E - 15	90109-081G1	E - 4	90185-16127	D - 6	90282-05034	B - 4	90462-10241	C - 8	91317-06016	F - 2
4SS-83922-01	E - 8	90109-142F4	D - 7	90185-20168	E - 5	90338-16148	D - 6	90464-13073	D - 5	91317-06025	B - 10
23X-83976-00	E - 15	90109-147F2	D - 7	90201-03313	B - 14	90340-12059	C - 7		F - 2	91317-06040	C - 7
5BF-83976-00	E - 15	90110-05201	D - 6	90201-05033	E - 12	90340-12112	B - 2	90464-13077	D - 5	91317-06050	C - 7
583-83981-00	E - 15	90110-08096	C - 15	90201-06057	E - 14	90340-14128	C - 8		F - 2	91317-06060	C - 7
5BF-84310-00	E - 13	90111-06017	B - 13	90201-06071	B - 9	90340-32123	C - 8	90464-15152	F - 2	91317-06075	C - 7
8G9-84314-00	E - 13	90119-06060	D - 4	90201-06557	D - 3	90387-0600F	D - 3	90464-15195	F - 2	91317-08020	C - 6
5BF-84319-00	E - 12	90119-06096	D - 3	90201-08089	E - 9	90387-0614M	B - 9	90464-16039	B - 14	91401-20012	E - 9
5BF-8433E-00	E - 13	90119-06163	D - 3	90201-08326	E - 4	90387-065L5	E - 14		D - 5	91401-25015	E - 9
5BF-84330-00	E - 13	90119-06214	D - 14	90201-08410	C - 3	90387-0701A	D - 3	90464-16061	F - 2	91808-16023	B - 2
5BF-84334-00	E - 13	90119-08238	D - 4	90201-08512	B - 8	90387-086N4	C - 15	90465-13275	F - 2	91812-16001	C - 8
5BF-84335-00	E - 13	90122-06035	B - 13	90201-086P8	C - 15	90387-1003G	E - 9	90465-16258	E - 8	92014-06016	E - 10
55U-84337-00	E - 13	90123-08090	E - 15	90201-087A9	C - 9	90387-124F4	C - 14	90467-08017	B - 14	92017-05008	E - 12
5BF-84397-00	E - 13	90146-06014	B - 13	90201-101A4	B - 2	90387-164N2	D - 6		D - 5	92017-08055	C - 15
5BF-84710-00	E - 14	90149-06011	D - 14	90201-101J1	E - 11	90387-164N3	D - 6	90467-09103	B - 14	92902-04100	C - 4
36Y-84714-40	E - 14	90149-06250	B - 4	90201-10118	E - 10	90387-167Y9	D - 6	90467-10008	D - 14	92907-06100	D - 15
4GY-84723-00	E - 14	90149-06286	C - 7		E - 8	90387-1712Y	C - 7	90467-11106	B - 3	92907-06600	B - 7
4GY-84733-00	E - 14	90149-06324	E - 11	90201-10119	E - 9	90387-1714R	D - 6	90467-12085	E - 10	92907-08200	E - 3
5BF-85540-00	F - 2	90149-06326	C - 7	90201-112U6	D - 9	90387-1714S	D - 6	90467-14015	B - 3	92990-10200	E - 9
5BF-85540-10	F - 2	90149-06327	E - 3	90201-12166	B - 10	90387-2113G	C - 11	90467-17089	B - 14	93101-14164	C - 8
5BE-85546-00	F - 2	90151-04048	D - 6	90201-125L6	C - 10	90387-225N2	E - 7	90468-16191	E - 9	93102-12106	B - 8
5BF-85550-00	E - 11	90152-06010	C - 9	90201-14740	D - 7	90387-2513F	C - 11	90480-14102	E - 14		C - 14
5BF-85560-00	E - 11	90154-05073	F - 2	90201-15701	C - 8	90401-08038	B - 12	90480-14323	D - 3	93102-12224	B - 7
5BE-85885-00	C - 4	90157-02031	E - 12	90201-162H4	C - 9	90401-10159	B - 12	90480-15528	B - 9		C - 10
9Y581-76113	E - 5	90159-06078	D - 4	90201-164H4	D - 6	90401-10172	E - 10	90480-17218	D - 2	93102-20108	C - 9
90101-06001	C - 9	90159-06092	C - 10		D - 7		E - 8	90480-18549	D - 14	93102-26468	E - 2
90101-06664	C - 14	90159-06182	D - 4	90201-167P7	C - 9	90413-06031	B - 14	90501-043E0	C - 8	93102-32480	C - 11
90101-08777	E - 5	90159-06189	E - 13	90201-20276	C - 9	90430-06014	B - 7	90501-052G5	C - 14	93106-22019	D - 6
90105-05361	D - 10	90170-14171	B - 4	90201-203U1	E - 5		B - 8	90501-06022	C - 13	93106-30044	E - 4
90105-065A1	C - 8	90170-20327	C - 10	90201-20685	C - 9	90430-08119	B - 12	90501-13720	C - 9	93106-30045	E - 4
90105-06553	C - 12	90170-24373	D - 10	90201-247L2	D - 10		C - 15	90501-16107	C - 9	93109-11073	B - 8
	C - 7	90179-06500	B - 3	90201-253K0	C - 11	90430-10188	B - 12	90501-23141	C - 10	93109-20076	D - 6
90105-067A6	B - 2	90179-06568	D - 6	90201-286K9	D - 10	90430-12213	C - 7	90506-16500	E - 9		D - 7
90105-08099	C - 15	90179-08270	B - 3	90202-03052	C - 3	90430-18130	C - 15	90506-35473	E - 9	93109-28043	D - 6
90105-08659	E - 3	90179-08299	E - 5	90202-05193	D - 14	90445-09100	D - 14	90508-142B5	C - 10	93210-07003	B - 12
90105-08752	C - 9	90179-08401	E - 15	90202-08045	B - 15	90445-09220	D - 14	90508-162B2	B - 7	93210-07135	B - 12
90105-10323	D - 8	90179-10247	E - 11	90206-06090	C - 6	90445-095K0	B - 14	90508-26561	C - 13	93210-09008	B - 12
90105-104A7	B - 2	90179-16672	E - 2	90209-06096	B - 13	90445-112K0	B - 2	90508-282B8	E - 9	93210-10197	B - 10
90105-105A2	D - 9	90179-20255	C - 10	90209-21332	C - 11	90445-114K8	D - 14	90508-282B9	E - 9		C - 7
90105-106A3	B - 2		C - 12	90209-26348	C - 11	90450-22017	B - 10	90508-291A8	C - 14	93210-11073	E - 9
90105-10728	E - 9	90179-28650	D - 10	90215-14204	B - 4	90450-25037	B - 9	90508-30743	C - 9	93210-12759	B - 12
90105-10733	C - 15	90183-06023	B - 14	90215-20231	C - 10	90450-28014	B - 9	91A20-05130	D - 4	93210-14369	C - 8
90109-063F8	C - 13		D - 3	90215-21256	C - 12	90450-57092	B - 13	91A21-05105	D - 4	93210-15620	E - 10
90109-06418	B - 7		D - 4	90215-21290	C - 10	90450-59091	B - 13	91314-06030	B - 10	93210-16500	B - 9
90109-065G2	B - 12	90183-06069	D - 4	90240-08120	E - 9	90460-15126	F - 2	91316-04008	B - 15	93210-19123	D - 2

NUMERICAL INDEX

PART NO.	GRID NO.	PART NO.	GRID NO.	PART NO.	GRID NO.	PART NO.	GRID NO.	PART NO.	GRID NO.	PART NO.	GRID NO.
93210-19216	C - 9	94212-18188	E - 4	95027-10020	E - 9	99001-08600	B - 10				
93210-19758	B - 8	94213-18232	E - 4	95301-08700	E - 10	99009-12400	B - 10				
93210-21276	F - 2	94227-21101	E - 2	95606-06100	E - 8	99009-16400	C - 9				
93210-22298	C - 11	94309-18146	E - 4	95607-05100	B - 13	99009-20400	C - 9				
93210-32172	C - 8	94309-21161	E - 2		E - 15	99009-22500	C - 8				
93210-50553	B - 12	94330-21084	E - 2	95607-06100	E - 15	99009-45500	E - 4				
93300-60804	C - 15	94340-18086	E - 4	95607-10200	C - 15	99241-00080	D - 3				
93306-00105	B - 8	94416-21613	E - 2		D - 8	99244-00200	D - 7				
93306-00426	C - 11	94421-18610	E - 4	95617-06635	B - 2	99530-08012	B - 10				
93306-00431	C - 11	94591-50120	B - 7	95617-08620	B - 2	99530-08016	C - 8				
93306-07202	E - 4	94681-76001	E - 5	95617-08635	B - 2	99530-10114	B - 10				
93306-20335	B - 4	94701-00329	B - 2	95617-10100	E - 9		C - 7				
93306-20532	C - 11	94701-00330	B - 2	95704-05500	C - 3	99530-10116	C - 7				
93306-20593	C - 11	94703-00329	B - 2	95707-06500	E - 14	99530-14016	C - 7				
93306-27205	E - 4	94703-00330	B - 2	95707-08500	B - 2						
93306-30633	B - 4	95021-08040	D - 12		C - 15						
93306-90403	E - 2	95024-06020	B - 11	95804-06010	C - 6						
93306-90501	C - 13	95027-06010	C - 10	95804-06016	C - 6						
93310-6340H	B - 4		D - 6	95817-08012	C - 6						
93311-62574	B - 4		E - 12	95817-10050	C - 15						
93315-11206	C - 10	95027-06012	B - 12	95817-10160	C - 15						
93315-32056	D - 6		B - 14	95827-06008	F - 2						
	D - 7		B - 9	95827-06012	E - 3						
93317-22262	D - 6		D - 3	95827-06014	B - 7						
93332-00068	D - 10		E - 10	95827-06016	D - 4						
93332-00081	D - 10		E - 6	95827-08012	C - 15						
93340-21505	C - 10	95027-06014	D - 3	95827-08016	C - 15						
93342-22217	D - 6	95027-06016	B - 14		D - 2						
93410-20038	C - 9		D - 14	97007-05016	E - 15						
93420-18082	B - 4		E - 6	97007-06012	D - 15						
93440-10085	B - 10	95027-06020	B - 12	97027-06016	B - 7						
	C - 10		C - 14	97706-40530	E - 14						
93440-10153	B - 2	95027-06025	B - 10	97707-50012	B - 13						
93440-25084	C - 11		B - 11	97707-60016	D - 3						
93440-28062	C - 11		B - 7	97780-40010	E - 14						
93440-41178	B - 7		B - 8	97780-50510	E - 10						
93501-04011	C - 9		B - 9	97801-03008	D - 14						
93503-08007	C - 8	95027-06030	C - 8	98502-04008	C - 4						
93603-17070	B - 10	95027-06040	B - 3	98502-04010	C - 4						
93604-10011	B - 8		C - 8	98507-04014	E - 15						
93608-33046	C - 14	95027-06050	D - 6	98507-05020	E - 7						
93612-16254	B - 3	95027-06065	B - 12	98507-06025	C - 7						
9383E-14210	C - 12	95027-08012	D - 2	98706-04012	E - 8						
94108-21008	E - 2	95027-08020	E - 3	98706-04040	E - 10						
94108-2115D	E - 2	95027-08035	D - 10	98707-06025	D - 14						
94111-18008	E - 4	95027-08040	C - 15	98907-05020	E - 15						
94111-1815E	E - 4		D - 10	98907-06020	D - 14						
94209-21229	E - 2	95027-08065	C - 15	98980-06008	C - 6						

# CONTENTS

## ENGINE

CYLINDER .....	B2
CRANKSHAFT. PISTON .....	B4
VALVE .....	B5
CAMSHAFT. CHAIN .....	B7
WATER PUMP .....	B8
RADIATOR. HOSE .....	B9
OIL PUMP .....	B10
OIL CLEANER .....	B12
INTAKE .....	B13
CARBURETOR .....	B15
EXHAUST .....	C6
CRANKCASE .....	C7
CRANKCASE COVER 1 .....	C8
STARTER .....	C9
CLUTCH .....	C10
TRANSMISSION .....	C11
SHIFT CAM. FORK .....	C13
SHIFT SHAFT .....	C14

## CHASSIS

FRAME .....	C15
FENDER .....	D3
SIDE COVER .....	D4
REAR ARM .....	D6
REAR SUSPENSION .....	D8
STEERING .....	D10
FRONT FORK .....	D11
FUEL TANK .....	D14
SEAT .....	D15
FRONT WHEEL .....	E2
FRONT BRAKE CALIPER .....	E3
REAR WHEEL .....	E4

REAR BRAKE CALIPER .....	E6
STEERING HANDLE. CABLE .....	E7
FRONT MASTER CYLINDER .....	E8
STAND. FOOTREST .....	E9
REAR MASTER CYLINDER .....	E10
GENERATOR .....	E11
METER .....	E12
HEADLIGHT .....	E13
TAILLIGHT .....	E14
HANDLE SWITCH. LEVER .....	E15
ELECTRICAL 1 .....	F2
ALTERNATE (CHASSIS) .....	F3

## INDEX

NUMERICAL INDEX .....	M1
-----------------------	----