



PARTS CATALOGUE

WR450FR (5TJ1) U49

WR450F (5TJ2) EUROPE

WR450FR (5TJ4) CANADA, OCEANIA, SOUTH AFRICA

YAMAHA
GENUINE
Parts & Accessories

1B5TJ-100E1

(2B5TJ-100E1)

WR450FR/WR450F
PARTS CATALOGUE
©2002 by Yamaha Motor Co., Ltd.
1st edition, November 2002
All rights reserved.
Any reprinting or unauthorized use
without the written permission of
Yamaha Motor Co., Ltd.
is expressly prohibited.
Printed in Japan.

A3

WR450FR/WR450F



A4

FOREWORD

This Parts Catalogue is related to the parts for the model(s) on the cover page. When you are ordering replacement parts, please refer to this Parts Catalogue and quote both part numbers and part names correctly.

1. Modifications or additions which have been made after the issue of the Parts Catalogue will be announced in the Yamaha Parts News.
It is advisable that you make the necessary corrections to the Parts Catalogue according to the Yamaha Parts News.

2. Abbreviations

The following abbreviations are used in this Parts Catalogue.

“UR” Use specified parts number.

“UN” Use as many as needed.

“AP” Alternate Parts

“LM” Locally Made (Parts need to be ordered locally)

“F#” Frame No. (Applicable machine No.)

“O/S” Over Size

3. The number of components for assembly

- Parts, which are to be supplied in an assembly, are listed with a dot (.) in front of the part name as shown below.
- The numeral appearing to the right of each component part indicates the quantity of parts for each assembly unit.

PART NO.	DESCRIPTION	Q'TY	REMARKS
2F5-83310-60	FRONT FLASHER LIGHT ASSY	2	
115-83311-60	.BULB (6V-18W)	1	

4. Applicable colours of graphics are represented in the “REMARKS” as shown below.

PART NO.	DESCRIPTION	Q'TY	REMARKS
2N4-24110-00-X5	FUEL TANK COMP.	2	MXR
3J1-24240-10	.GRAPHIC, FUEL TANK	1	FOR MXR

5. Note that the illustrations for reference in finding parts numbers are not to be used for assembling. When assembling, please use the applicable service manual.

6. The asterisk (*) before a reference number indicates modified items after the first edition.

FOREWORD

7. Applicable Serial No.

Engine Serial No.

Frame Serial No.

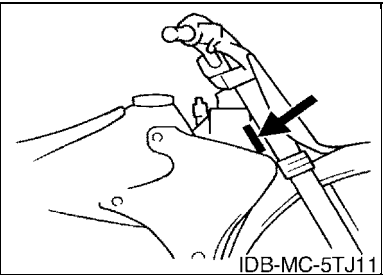
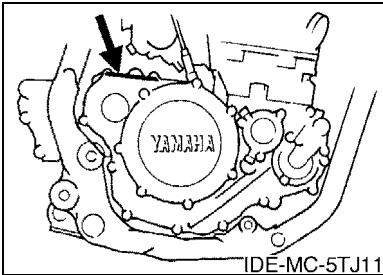

8. Applicable Colour Code

Abbreviation	Colour Name	Colour Code

MODEL LABEL

(1) A label called "Model Label" is affixed in the location as indicated in (3) below. When using this parts catalogue, please be sure to cross-reference the "model code – production code No." in the catalogue with the "model code – production code No." indicated on the Model Label affixed onto the product concerned.

(2) "Model Label" Indication

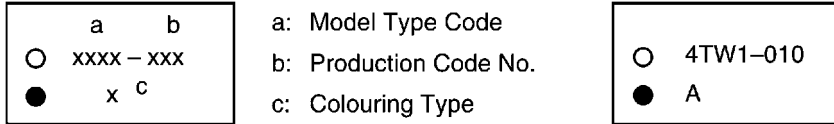

(3) Model Label Affixing Location

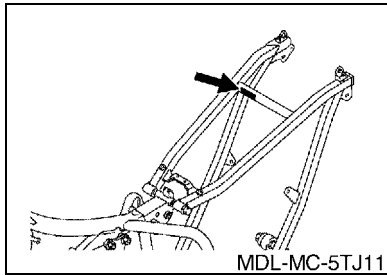

(4) Colouring Information

Model Code	Colouring Type Code	Colour Code	Colour Name	Abbreviation
5TJ1	A	0583	DEEP PURPLISH BLUE SOLID E	DPBSE
5TJ2	A	0583	DEEP PURPLISH BLUE SOLID E	DPBSE
5TJ4	A	0583	DEEP PURPLISH BLUE SOLID E	DPBSE

(5) Model Code – Production Code Number of Model Listed in This Parts Catalogue

Model Code	Production Code No.	Country (destination)	Model Code	Production Code No.	Country (destination)
5TJ1	010	U49			
5TJ2	010	FRANCE			
	020	BELGIUM			
	030	GERMANY			
	040	SPAIN			
	050	FINLAND			
		IRELAND			
	060	UNITED KINGDOM			
	070	GREECE			
	080	ITALY			
	090	PORTUGAL			
100	SWEDEN				
5TJ4	010	AUSTRALIA			
	020	CANADA			
	030	NEW ZEALAND			
	040	SOUTH AFRICA			

CONTENTS

ENGINE

CYLINDER	B2
CRANKSHAFT. PISTON	B4
VALVE	B5
CAMSHAFT. CHAIN	B7
WATER PUMP	B8
RADIATOR. HOSE	B9
OIL PUMP	B10
OIL CLEANER	B11
INTAKE	B12
CARBURETOR	B14
EXHAUST	C4
CRANKCASE	C5
CRANKCASE COVER 1	C6
STARTER	C8
STARTER CLUTCH	C9
CLUTCH	C10
TRANSMISSION	C12
SHIFT CAM. FORK	C14
SHIFT SHAFT	C15

CHASSIS

FRAME	D2
FENDER	D4
SIDE COVER	D5
REAR ARM	D6
REAR SUSPENSION	D8
STEERING	D10
FRONT FORK	D11
FUEL TANK	D14
SEAT	E2
FRONT WHEEL	E3
FRONT BRAKE CALIPER	E4
REAR WHEEL	E5
REAR BRAKE CALIPER	E7
STEERING HANDLE. CABLE	E8
FRONT MASTER CYLINDER	E9
STAND. FOOTREST	E10
REAR MASTER CYLINDER	E11
GENERATOR	E12
STARTING MOTOR	E13
METER	E14

HEADLIGHT	E15
TAILLIGHT	F2
HANDLE SWITCH. LEVER	F3
ELECTRICAL 1	F4
ALTERNATE (CHASSIS)	F6
ALTERNATE	F8

INDEX

NUMERICAL INDEX	M1
-----------------------	----

FIG. 1 CYLINDER

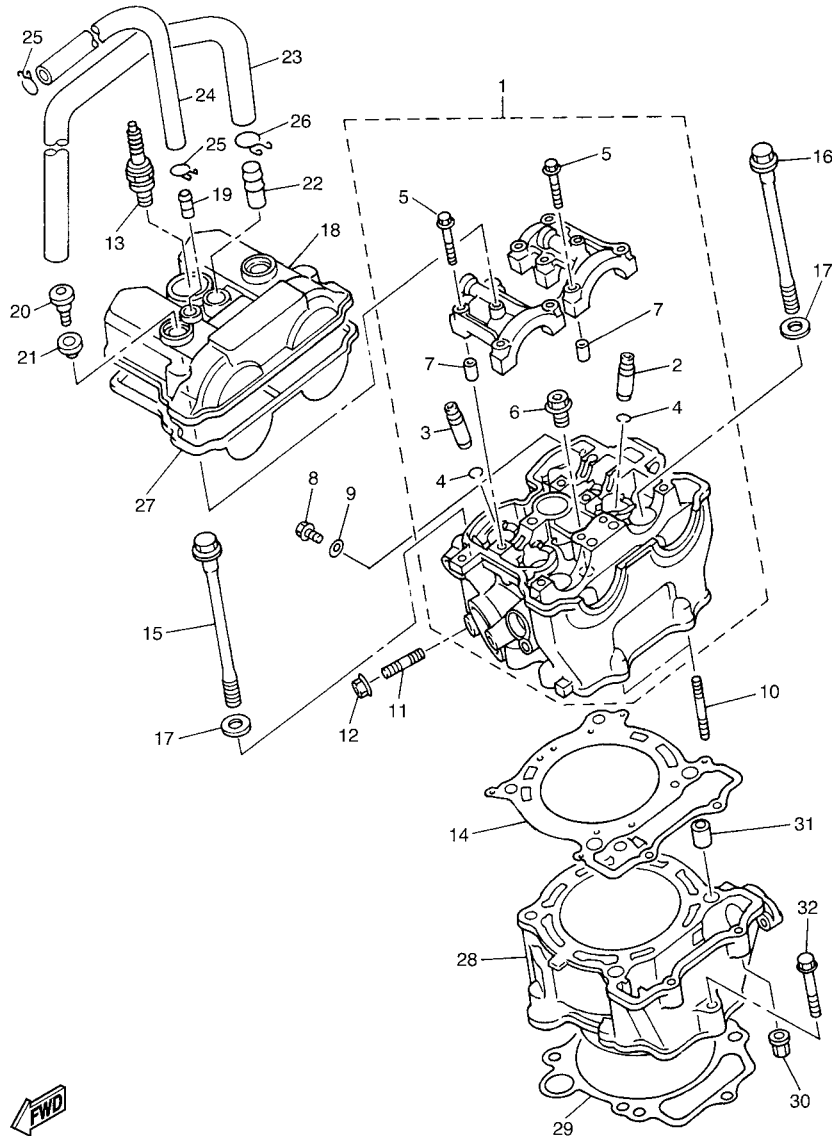

5TA1100-B010

REF. NO.	PART NO.	DESCRIPTION	5TJ1	5TJ2	5TJ4	REMARKS
1	5TA-11102-00	CYLINDER HEAD ASSY	1	1	1	
2	5TA-11133-10	.GUIDE, INTAKE VALVE	3	3	3	
3	5TA-11134-10	.GUIDE, EXHAUST VALVE	2	2	2	
4	93440-10153	.CIRCLIP	5	5	5	
5	90105-06027	.BOLT, FLANGE	10	10	10	
6	90340-12112	.PLUG, STRAIGHT SCREW	1	1	1	
7	91808-16023	.PIN, DOWEL	4	4	4	
8	95027-06010	BOLT, FLANGE	1	1	1	
9	90430-06014	GASKET	1	1	1	
10	95617-06635	BOLT, STUD	2	2	2	
11	95617-08620	BOLT, STUD	1	1	1	
12	95707-08500	NUT, FLANGE	1	1	1	
13	94701-00411	PLUG, SPARK (NGK R CR8E)	1	1	1	
14	5TA-11181-00	GASKET, CYLINDER HEAD 1	1	1	1	
15	90105-104A7	BOLT, FLANGE	2	2	2	
16	90105-106A3	BOLT, FLANGE	2	2	2	
17	90201-10025	WASHER, PLATE	4	4	4	
18	5TA-11191-00	COVER, CYLINDER HEAD 1	1	1	1	
19	5BE-11167-00	PIPE, BREATHER 2	1	1	1	
20	90109-066F0	BOLT	2	2	2	
21	4KG-1111G-00	RUBBER, MOUNT 1	2	2	2	
22	371-11167-01	PIPE, BREATHER 2	1	1	1	
23	5TA-11166-00	PIPE, BREATHER 1	1	1	1	
24	90445-112K0	HOSE (L285)	1	1	1	
25	90467-11106	CLIP	2	2	2	
26	90467-14015	CLIP	1	1	1	
27	5TA-11193-00	GASKET, HEAD COVER 1	1	1	1	

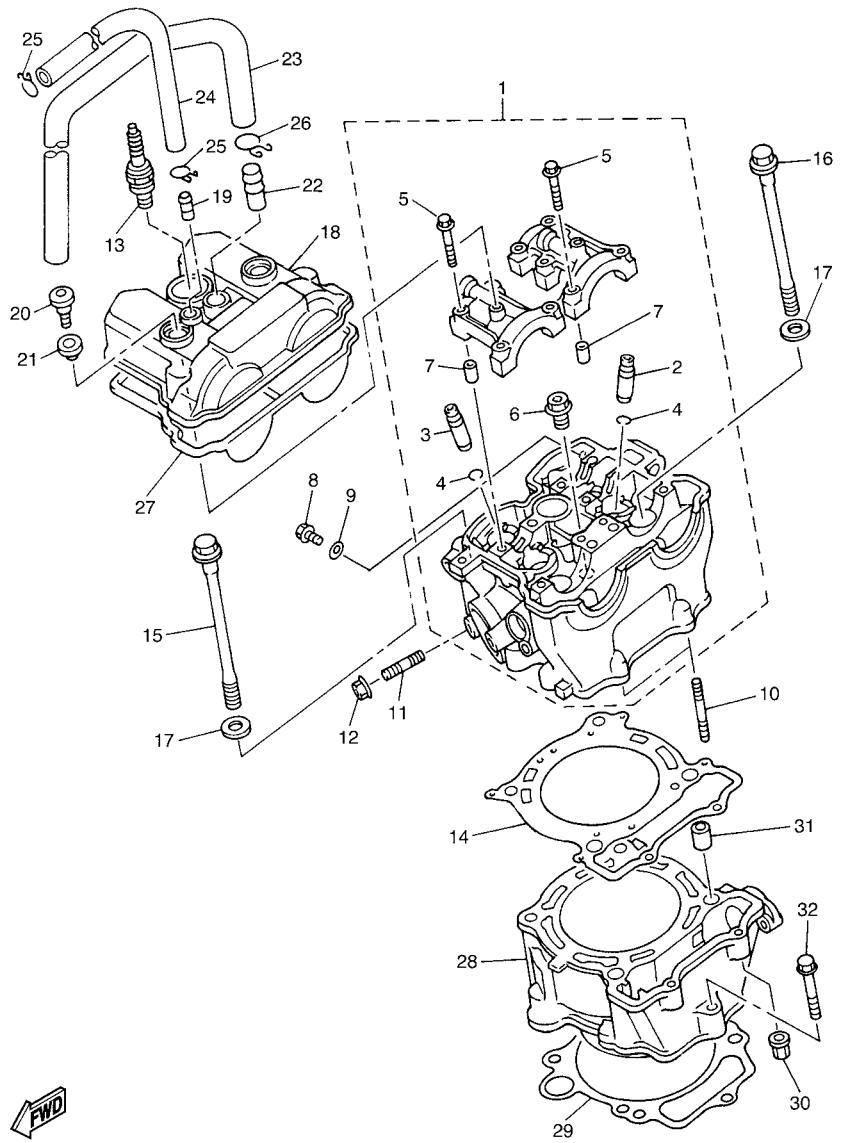

5TA1100-B010

FIG. 1 CYLINDER

REF. NO.	PART NO.	DESCRIPTION	5TJ1	5TJ2	5TJ4	REMARKS
28	5TA-11311-01	CYLINDER 1	1	1	1	
29	5TA-11351-00	GASKET, CYLINDER	1	1	1	
30	90179-06500	NUT	2	2	2	
31	93612-16254	PIN, DOWEL	2	2	2	
32	95027-06035	BOLT, FLANGE	1	1	1	

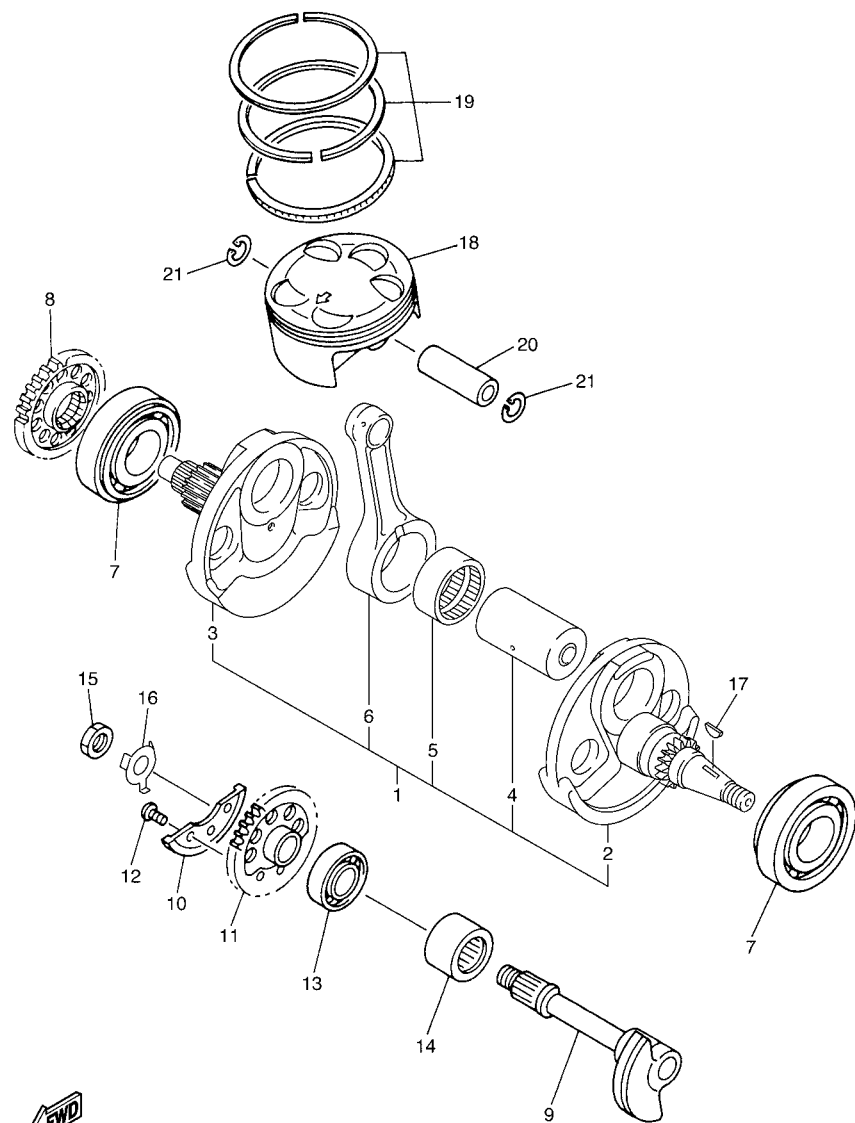

5TA1100-B020

FIG. 2 CRANKSHAFT. PISTON

REF. NO.	PART NO.	DESCRIPTION	5TJ1	5TJ2	5TJ4	REMARKS
1	5TJ-11400-00	CRANKSHAFT ASSY	1	1	1	
2	5TJ-11412-00	.CRANK 1	1	1	1	
3	5TA-11422-00	.CRANK 2	1	1	1	
4	5TA-11681-00	.PIN, CRANK 1	1	1	1	
5	93310-63417	.BEARING	1	1	1	
6	5TA-11651-00	.ROD, CONNECTING	1	1	1	
7	93306-30633	BEARING	2	2	2	
8	5TA-11536-00	GEAR, DRIVE	1	1	1	
9	5TA-11455-00	SHAFT 1	1	1	1	
10	5BE-11454-00	WEIGHT 1	1	1	1	
11	5TA-11531-01	GEAR, BALANCE WEIGHT	1	1	1	
12	90149-06250	SCREW	3	3	3	
13	93306-20335	BEARING	1	1	1	
14	93311-62574	BEARING	1	1	1	
15	90170-14171	NUT	1	1	1	
16	90215-14287	WASHER, LOCK	1	1	1	
17	90280-03001	KEY, WOODRUFF	1	1	1	
18	5TA-11631-00	PISTON (STD)	1	1	1	
19	5JG-11603-00	PISTON RING SET (STD)	1	1	1	
20	5TA-11633-00	PIN, PISTON	1	1	1	
21	93420-18082	CIRCLIP	2	2	2	

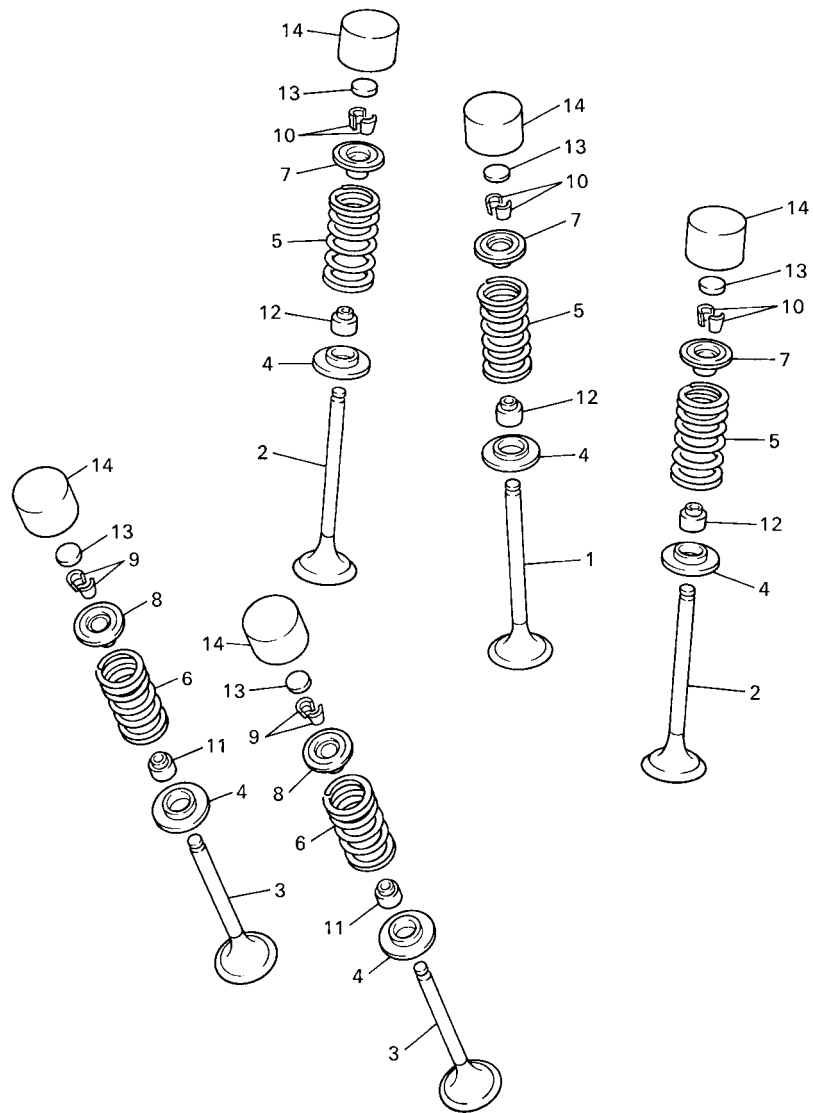

5BE100-8030

FIG. 3 VALVE

REF. NO.	PART NO.	DESCRIPTION	5TJ1	5TJ2	5TJ4	REMARKS
1	5TA-12111-00	VALVE, INTAKE	1	1	1	
2	5TA-12112-00	VALVE, INTAKE 2	2	2	2	
3	5TA-12121-00	VALVE, EXHAUST	2	2	2	
4	3GM-12126-00	SEAT, VALVE SPRING 2	5	5	5	
5	5TA-12113-00	SPRING, VALVE INNER	3	3	3	
6	5TA-12114-00	SPRING, VALVE OUTER	2	2	2	
7	5BE-12117-00	RETAINER, VALVE SPRING	3	3	3	
8	4GY-12117-00	RETAINER, VALVE SPRING	2	2	2	
9	1AA-12118-00	COTTER, VALVE	4	4	4	
10	1WG-12118-00	COTTER, VALVE	6	6	6	
11	33M-12119-00	SEAL, VALVE STEM	2	2	2	
12	4SV-12119-00	SEAL, VALVE STEM	3	3	3	
13	3LD-12168-00	PAD, ADJUSTING (1.20)	5	5	5	UR
	3LD-12168-20	PAD, ADJUSTING (1.25)	5	5	5	UR
	3LD-12168-40	PAD, ADJUSTING (1.30)	5	5	5	UR
	3LD-12168-60	PAD, ADJUSTING (1.35)	5	5	5	UR
	3LD-12168-80	PAD, ADJUSTING (1.40)	5	5	5	UR
	3LD-12168-A0	PAD, ADJUSTING (1.45)	5	5	5	UR
	3LD-12168-F0	PAD, ADJUSTING (1.50)	5	5	5	UR
	3LD-12168-H1	PAD, ADJUSTING (1.55)	5	5	5	UR
	3LD-12168-K1	PAD, ADJUSTING (1.60)	5	5	5	UR
	3LD-12168-M1	PAD, ADJUSTING (1.65)	5	5	5	UR
	3LD-12168-R1	PAD, ADJUSTING (1.70)	5	5	5	UR
	3LD-12168-U1	PAD, ADJUSTING (1.75)	5	5	5	UR
	3LD-12168-W1	PAD, ADJUSTING (1.80)	5	5	5	UR
	3LD-12168-Y1	PAD, ADJUSTING (1.85)	5	5	5	UR
	3LD-12169-11	PAD, ADJUSTING (1.90)	5	5	5	UR

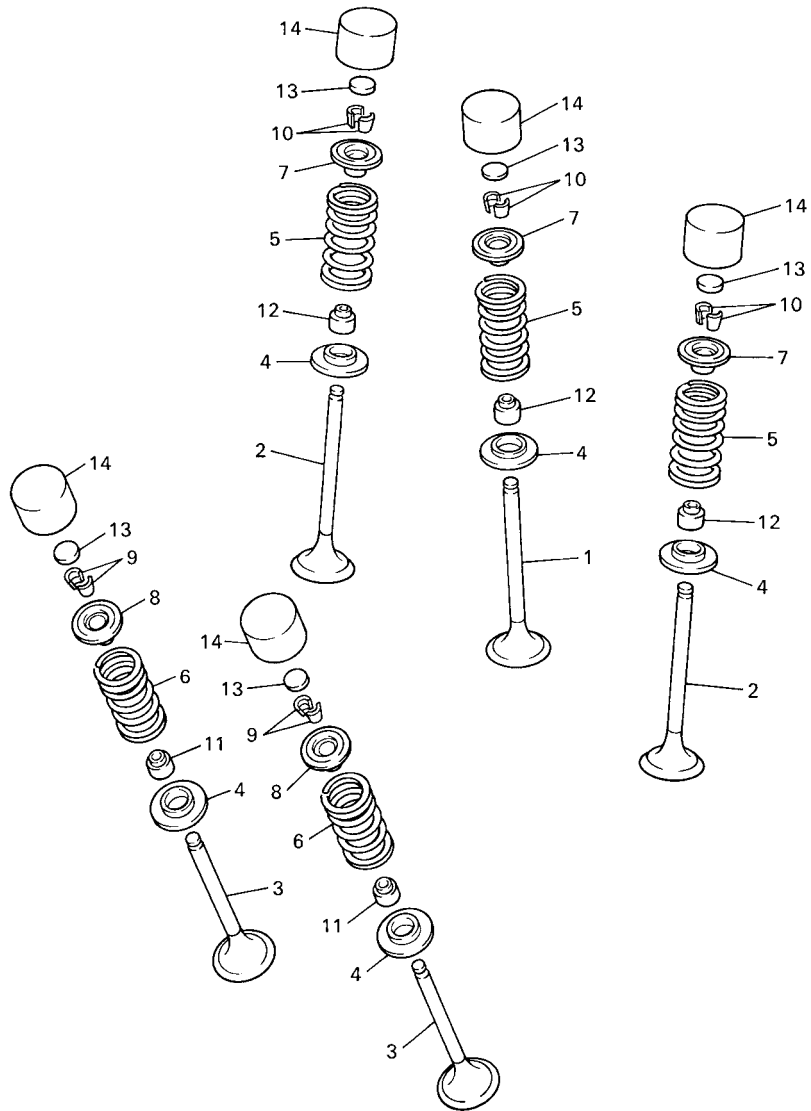

5BE100-8030

FIG. 3 VALVE

REF. NO.	PART NO.	DESCRIPTION	5TJ1	5TJ2	5TJ4	REMARKS
13	3LD-12169-31	PAD, ADJUSTING (1.95)	5	5	5	UR
	3LD-12169-50	PAD, ADJUSTING (2.00)	5	5	5	UR
	3LD-12169-70	PAD, ADJUSTING (2.05)	5	5	5	UR
	3LD-12169-90	PAD, ADJUSTING (2.10)	5	5	5	UR
	3LD-12169-E0	PAD, ADJUSTING (2.15)	5	5	5	UR
	3LD-12169-G0	PAD, ADJUSTING (2.20)	5	5	5	UR
	3LD-12169-J0	PAD, ADJUSTING (2.25)	5	5	5	UR
	3LD-12169-L0	PAD, ADJUSTING (2.30)	5	5	5	UR
	3LD-12169-N0	PAD, ADJUSTING (2.35)	5	5	5	UR
	3LD-12169-T0	PAD, ADJUSTING (2.40)	5	5	5	UR
14	3FV-12153-00	LIFTER, VALVE	5	5	5	UR BLACK
	3FV-12153-10	LIFTER, VALVE	5	5	5	UR YELLOW
	3FV-12153-20	LIFTER, VALVE	5	5	5	UR BLUE

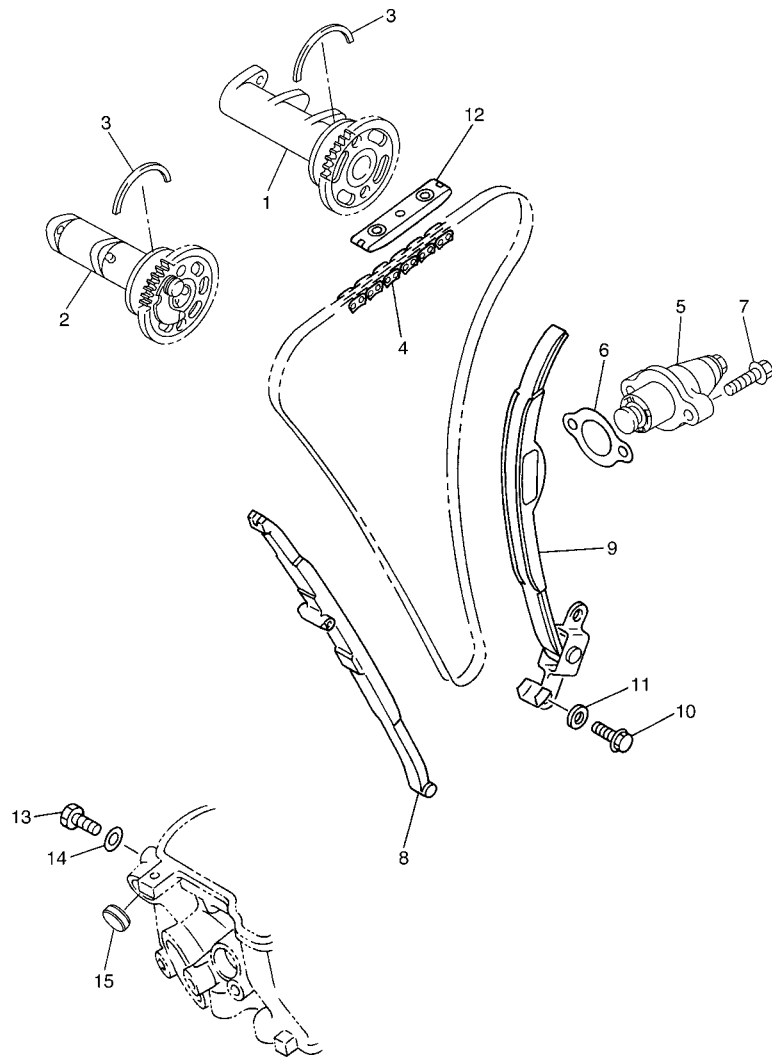

5TA1100-B040

FIG. 4 CAMSHAFT. CHAIN

REF. NO.	PART NO.	DESCRIPTION	5TJ1	5TJ2	5TJ4	REMARKS
1	5TA-12170-00	CAMSHAFT ASSY 1	1	1	1	
2	5TJ-12180-10	CAMSHAFT ASSY 2	1	1	1	
3	93440-41178	CIRCLIP	2	2	2	
4	94591-57118	CHAIN	1	1	1	
5	5TA-12210-00	TENSIONER ASSY, CAM CHAIN	1	1	1	
6	4FM-12213-00	GASKET, TENSIONER CASE	1	1	1	
7	95027-06025	BOLT, FLANGE	2	2	2	
8	5TA-12251-01	DAMPER, CHAIN 1	1	1	1	
9	5TA-12252-00	DAMPER, CHAIN 2	1	1	1	
10	97027-06016	BOLT	2	2	2	
11	92907-06600	WASHER, PLATE	2	2	2	
12	5BE-12241-00	GUIDE, STOPPER 2	1	1	1	
13	90109-06418	BOLT	1	1	1	
14	90430-06014	GASKET	1	1	1	
15	90338-18064	PLUG	1	1	1	

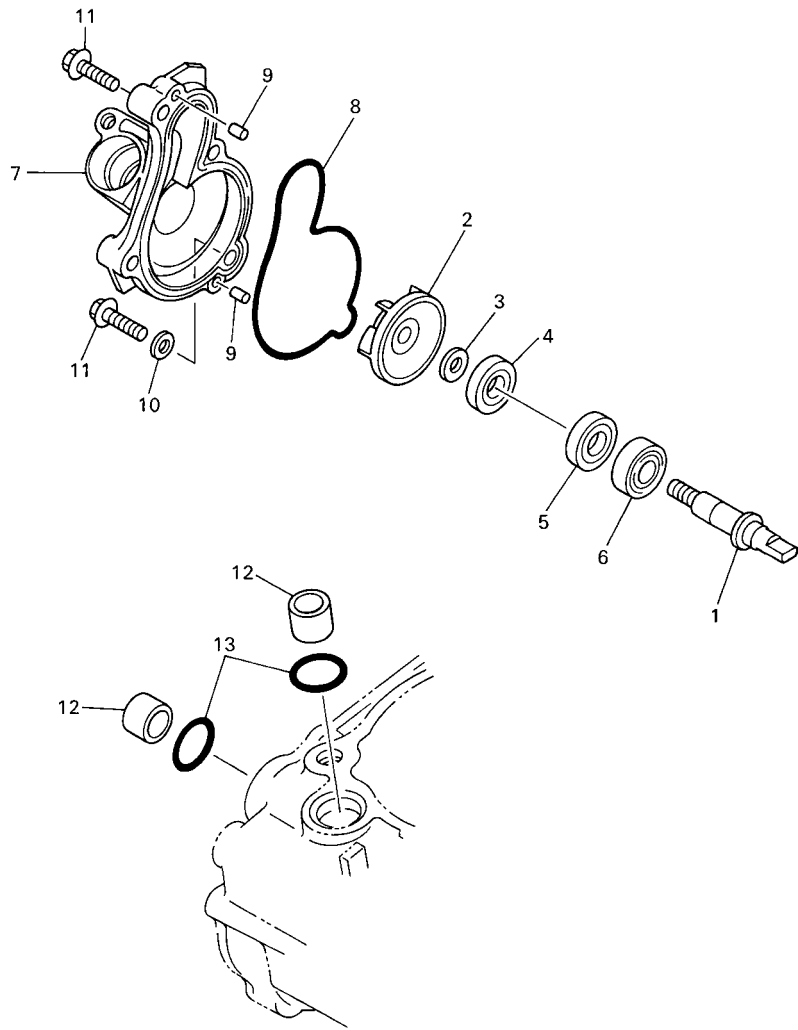

FIG. 5 WATER PUMP

REF. NO.	PART NO.	DESCRIPTION	5TJ1	5TJ2	5TJ4	REMARKS
1	5GR-12458-00	SHAFT, IMPELLER	1	1	1	
2	5DJ-12451-00	IMPELLER, WATER PUMP	1	1	1	
3	90201-08512	WASHER, PLATE	1	1	1	
4	93109-11073	OIL SEAL	1	1	1	
5	93102-12106	OIL SEAL (SD 12-22-5 HS)	1	1	1	
6	93306-00105	BEARING (B6001)	1	1	1	
7	5BE-12422-20	COVER, HOUSING	1	1	1	
8	5BE-12439-00	O-RING	1	1	1	
9	93604-10011	PIN, DOWEL	2	2	2	
10	90430-06014	GASKET	1	1	1	
11	95027-06030	BOLT, FLANGE	4	4	4	
12	5BE-12564-00	PIPE, WATER	2	2	2	
13	93210-19758	O-RING	2	2	2	



5BE100-8050

FIG. 6 RADIATOR. HOSE

REF. NO.	PART NO.	DESCRIPTION				REMARKS
			5TJ1	5TJ2	5TJ4	
1	5TJ-1240A-00	RADIATOR ASSY	1	1	1	
2	5TJ-12461-00	RADIATOR ASSY	1	1	1	
3	5HD-12462-00	CAP, RADIATOR	1	1	1	
4	5TA-12481-00	PIPE 1	1	1	1	
5	95027-06012	BOLT, FLANGE	1	1	1	
6	93210-16500	O-RING	1	1	1	
7	5TA-12576-00	HOSE 1	1	1	1	
8	5SG-12579-00	HOSE 4	1	1	1	
9	5TA-12578-00	HOSE 3	1	1	1	
10	5TA-12579-00	HOSE 4	1	1	1	
11	5TA-12482-00	PIPE 2	1	1	1	
12	95027-06012	BOLT, FLANGE	1	1	1	
13	93210-16500	O-RING	1	1	1	
14	90450-28014	HOSE CLAMP ASSY	3	3	3	
15	90450-25037	HOSE CLAMP ASSY	3	3	3	
16	90450-22017	HOSE CLAMP ASSY	2	2	2	
17	90480-15528	GROMMET	6	6	6	
18	90387-06065	COLLAR	6	6	6	
19	95027-06025	BOLT, FLANGE	6	6	6	
20	90201-06571	WASHER, PLATE	6	6	6	
21	95827-06010	BOLT, FLANGE	2	2	2	

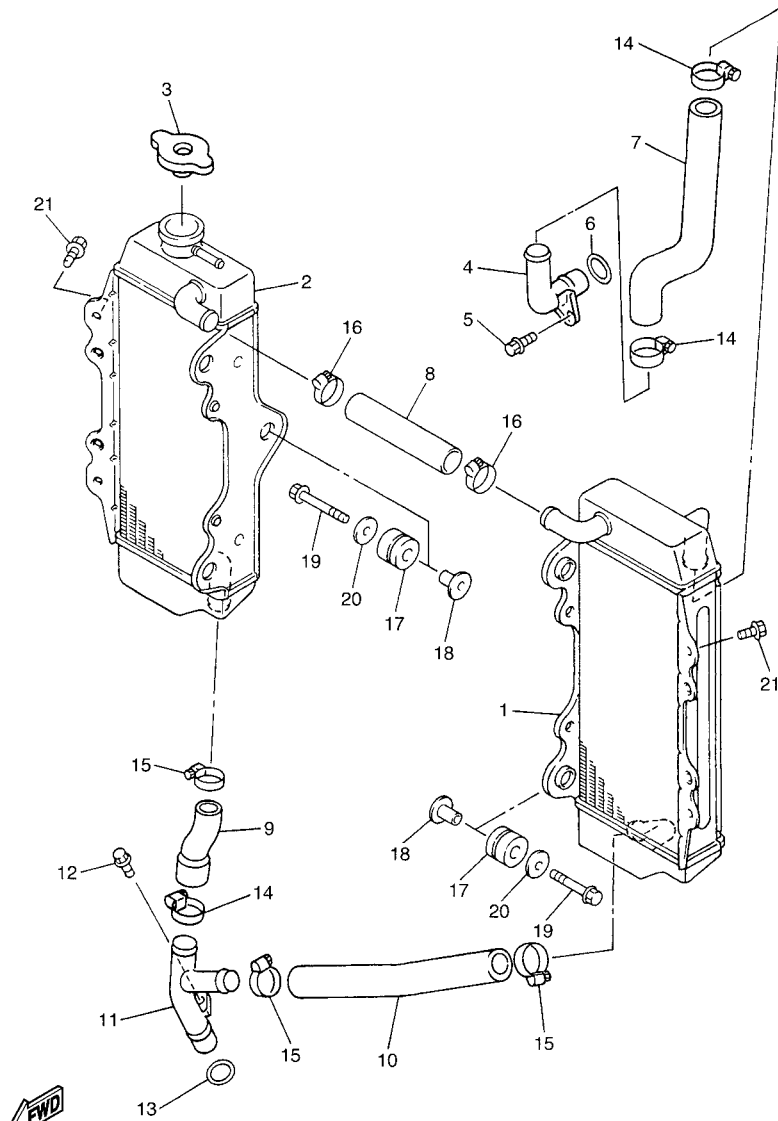

5TJ1100-B060

FIG. 7 OIL PUMP

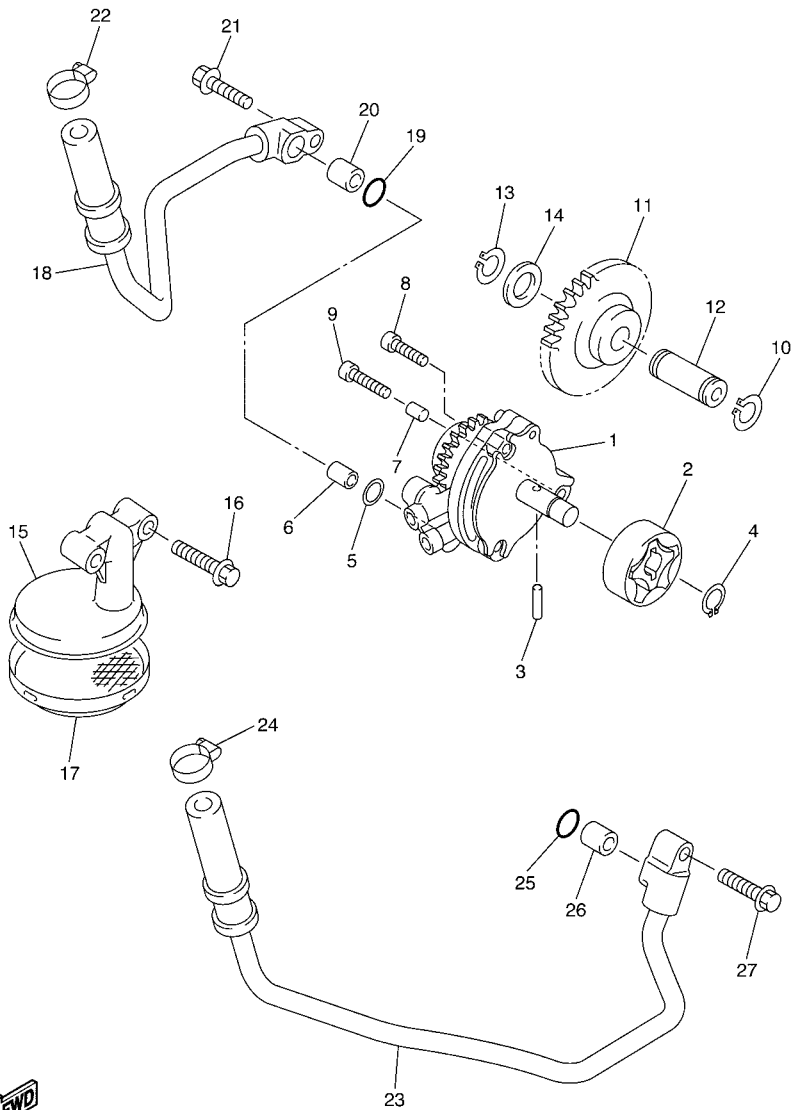

5TA1100-B070

REF. NO.	PART NO.	DESCRIPTION	5TJ1	5TJ2	5TJ4	REMARKS
1	5TA-13300-00	OIL PUMP ASSY	1	1	1	
2	5TA-13320-00	ROTOR ASSY 2	1	1	1	
3	93603-16219	PIN, DOWEL	1	1	1	
4	93440-10153	CIRCLIP	1	1	1	
5	93210-10197	O-RING	1	1	1	
6	99530-10114	PIN, DOWEL	1	1	1	
7	99530-08012	PIN, DOWEL	1	1	1	
8	90110-06058	BOLT, HEXAGON SOCKET HEAD	2	2	2	
9	91314-06030	BOLT	1	1	1	
10	99001-08600	CIRCLIP	1	1	1	
11	5TA-13341-00	GEAR, OIL PUMP IDLE	1	1	1	
12	5BE-13342-00	SHAFT, IDLE GEAR	1	1	1	
13	99009-12400	CIRCLIP	1	1	1	
14	90201-12166	WASHER, PLATE	1	1	1	
15	5TA-13412-00	HOUSING, STRAINER	1	1	1	
16	95027-06025	BOLT, FLANGE	2	2	2	
17	5BE-13411-00	STRAINER, OIL	1	1	1	
18	5TA-13464-00	HOSE, OIL 1	1	1	1	
19	93210-10197	O-RING	1	1	1	
20	99530-10114	PIN, DOWEL	1	1	1	
21	95027-06025	BOLT, FLANGE	1	1	1	
22	90450-22017	HOSE CLAMP ASSY	1	1	1	
23	5TA-13465-00	HOSE, OIL 2	1	1	1	
24	90450-22017	HOSE CLAMP ASSY	1	1	1	
25	93210-10197	O-RING	1	1	1	
26	99530-10114	PIN, DOWEL	1	1	1	
27	95027-06025	BOLT, FLANGE	1	1	1	

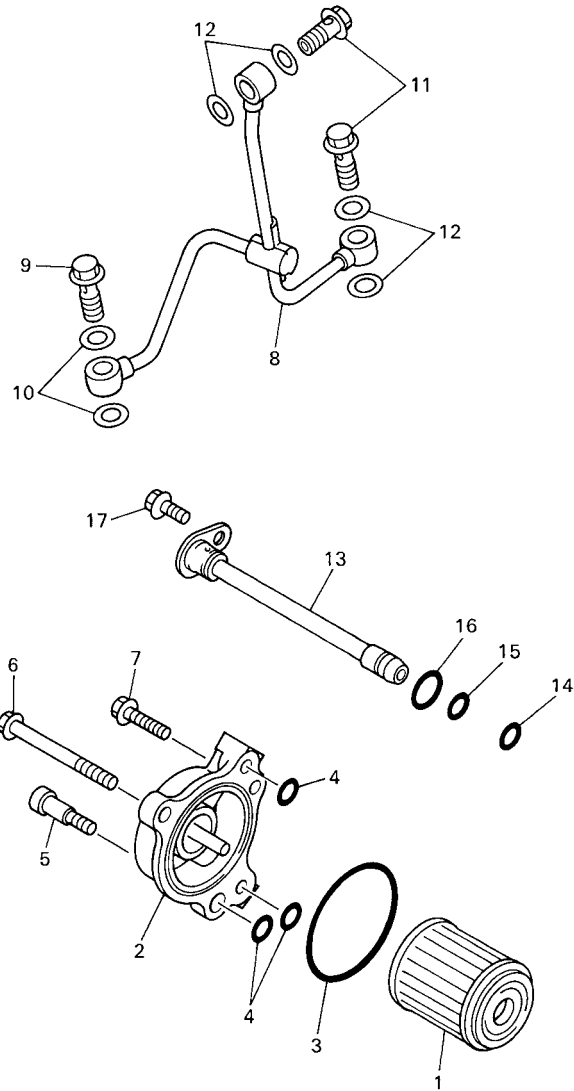

5BE100-8080

FIG. 8 OIL CLEANER

REF. NO.	PART NO.	DESCRIPTION	5TJ1	5TJ2	5TJ4	REMARKS
1	5TA-13440-00	ELEMENT ASSY, OIL CLEANER	1	1	1	
2	5BE-13447-10	COVER, OIL ELEMENT	1	1	1	
3	93210-47675	O-RING	1	1	1	
4	93210-07135	O-RING	3	3	3	
5	90109-065G2	BOLT	1	1	1	
6	95027-06065	BOLT, FLANGE	1	1	1	
7	95027-06020	BOLT, FLANGE	1	1	1	
8	5TA-13161-00	PIPE, DELIVERY 1	1	1	1	
9	90401-10159	BOLT, UNION	1	1	1	
10	90430-10188	GASKET	2	2	2	
11	90401-08038	BOLT, UNION	2	2	2	
12	90430-08119	GASKET	4	4	4	
13	5TA-13171-00	PIPE, DELIVERY 2	1	1	1	
14	93210-07003	O-RING	1	1	1	
15	93210-09008	O-RING	1	1	1	
16	93210-12759	O-RING	1	1	1	
17	95027-06012	BOLT, FLANGE	1	1	1	

FIG. 9 INTAKE

REF. NO.	PART NO.	DESCRIPTION	5TJ1	5TJ2	5TJ4	REMARKS
1	5TA-13597-00	JOINT, CARBURETOR 3	1	1	1	
2	90450-57004	HOSE CLAMP ASSY	1	1	1	
3	90450-59002	HOSE CLAMP ASSY	1	1	1	
4	5TA-14293-00	COVER 1	1	1	1	
5	5TA-14227-00	GASKET	1	1	1	
6	5TA-14239-00	SEAL	1	1	1	
7	5TA-14987-00	HOSE	1	1	1	
8	3TJ-14137-40	CLIP	1	1	1	
9	5TA-14428-00	BOLT	2	2	2	
10	90450-61001	HOSE CLAMP ASSY	1	1	1	
11	5TJ-14401-00	AIR CLEANER CASE ASSY	1	1	1	
12	5TA-14453-00	JOINT, AIR CLEANER 1	1	1	1	
13	5TJ-14459-00	HOLDER, GUIDE	1	1	1	
14	5NY-14455-10	BAND	1	1	1	
15	5NY-14442-00	SPACER	1	1	1	
16	5TJ-14451-00	ELEMENT, AIR CLEANER	1	1	1	
17	5TJ-14475-00	WASHER	1	1	1	
18	5TJ-1441G-00	BINDER 1	1	1	1	
19	5TJ-14458-00	GUIDE	1	1	1	
20	4XV-2177L-00	PLATE, SPRING	3	3	3	
21	5TJ-1441E-00	COVER, CLEANER CASE 2	1	1	1	
22	90267-32146	RIVET, BLIND	2	2	2	
23	90201-03313	WASHER, PLATE	2	2	2	
24	5TJ-14437-00	DUCT	1	1	1	
25	5TJ-14425-00	DAMPER 1	2	2	2	
26	5TJ-14426-00	DAMPER 2	3	3	3	
27	5TJ-14436-00	HOOK	1	1	1	

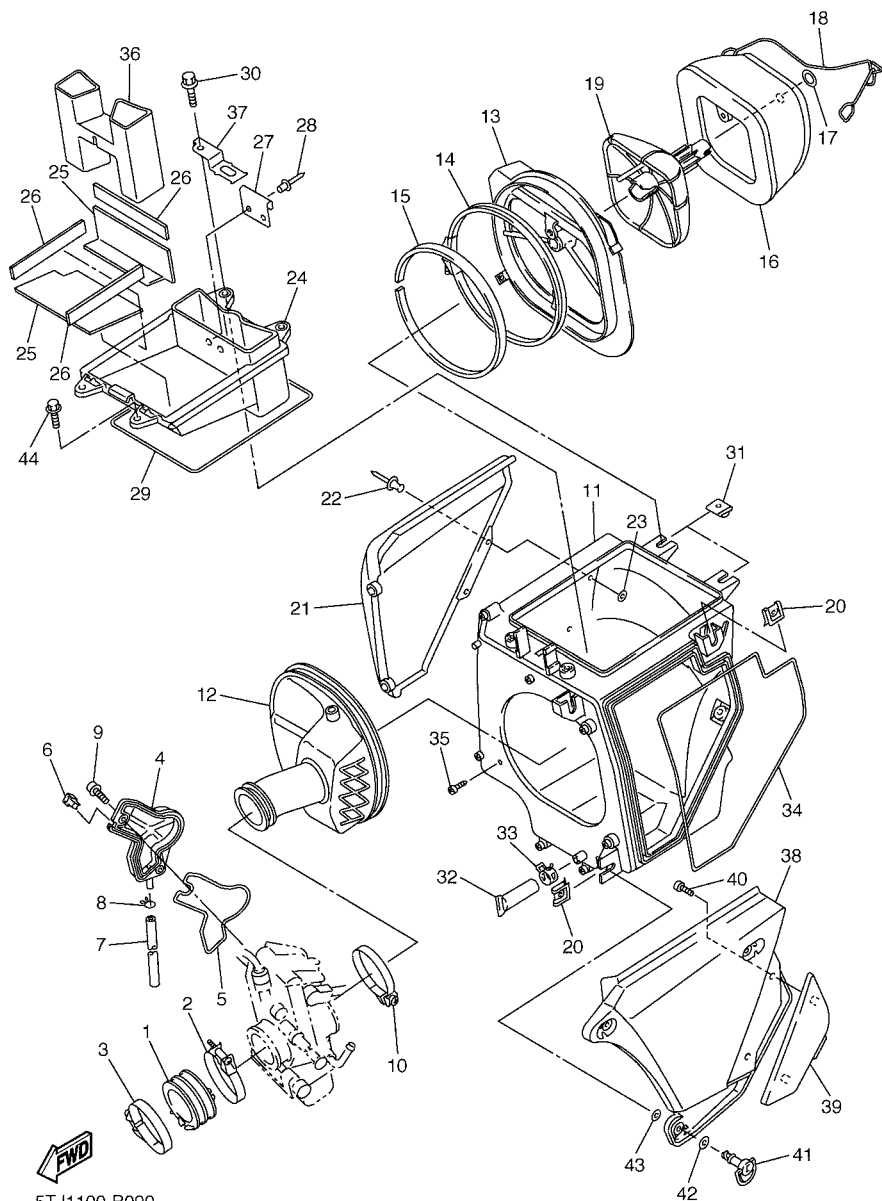

5TJ1100-B090

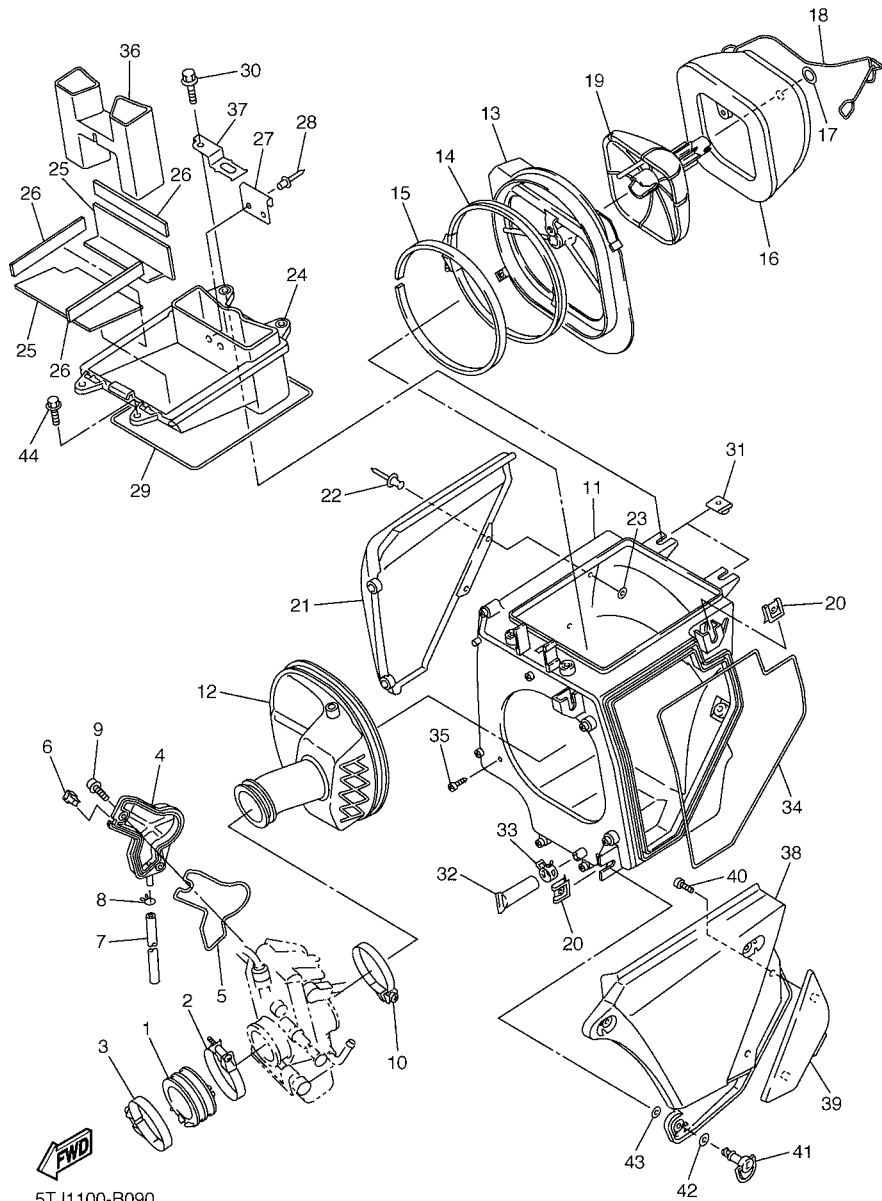

5TJ1100-B090

FIG. 9 INTAKE

REF. NO.	PART NO.	DESCRIPTION	5TJ1	5TJ2	5TJ4	REMARKS
28	90267-32146	RIVET, BLIND	2	2	2	
29	5TJ-14457-00	SEAL	1	1	1	
30	95027-06020	BOLT, FLANGE	2	2	2	
31	90183-06023	NUT, SPRING	2	2	2	
32	5BF-1443E-00	PIPE, DRAIN	1	1	1	
33	90467-17089	CLIP	1	1	1	
34	5TJ-14462-00	SEAL	1	1	1	
35	97707-50516	SCREW, TAPPING	1	1	1	
36	5TJ-1443A-00	DUCT	1			
37	5TJ-81953-00	STAY, RELAY	1	1	1	
38	5TJ-1441A-00	COVER, CLEANER CASE 1	1	1	1	
39	5TJ-1442A-00	COVER, CLEANER CASE 3	1	1	1	
40	97707-30512	SCREW, TAPPING	2	2	2	
41	3FV-28386-00	HEAD	3	3	3	
42	2TK-21757-00	WASHER, SPECIAL 1	3	3	3	
43	5TJ-21757-00	WASHER, SPECIAL 1	3	3	3	
44	95827-06016	BOLT, FLANGE	2	2	2	

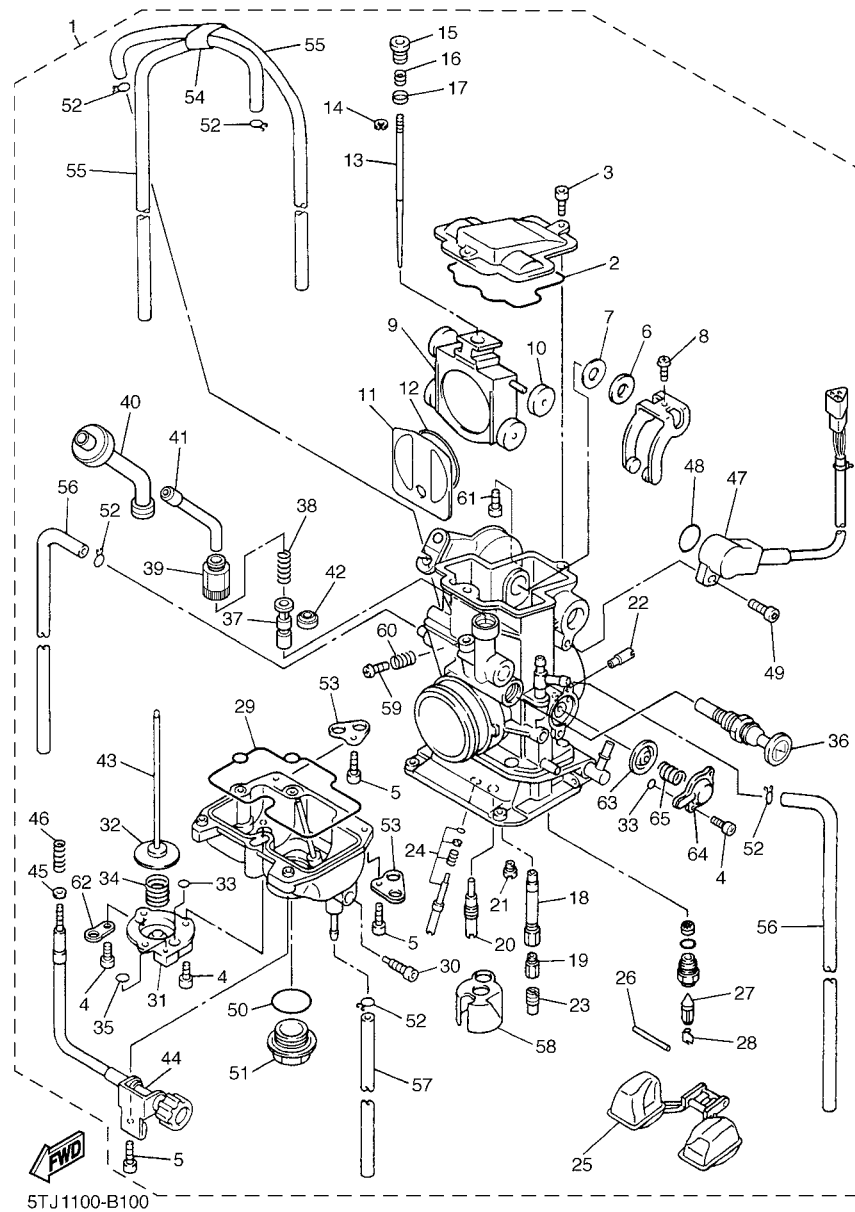

5TJ1100-B100

FIG. 10 CARBURETOR

REF. NO.	PART NO.	DESCRIPTION	5TJ1	5TJ2	5TJ4	REMARKS
1	5TJ-14101-00	CARBURETOR ASSY 1	1			
	5TJ-14101-10	CARBURETOR ASSY 1		1	1	
2	5JG-14959-00	.GASKET	1	1	1	
3	91316-04012	.BOLT	2	2	2	
4	688-14592-00	.SCREW	5	5	5	
5	98502-04012	.SCREW, PAN HEAD	4	4	4	
6	90202-08045	.WASHER, PLATE	1	1	1	
7	5JG-14951-00	.WASHER	1	1	1	
8	5JG-14522-00	.SCREW, ADJUST	1	1	1	
9	5JG-14388-00	.VALVE, VACUUM CONTROL	1	1	1	
10	3TJ-14267-40	.ROLLER	1	1	1	
11	5JG-14546-01	.VALVE, NEEDLE	1	1	1	
12	4FN-14997-00	.SEAL	1	1	1	
13	5TJ-14916-DT	.NEEDLE (#DUT)	1			STD
	5TJ-14916-D1	.NEEDLE (#DUQ)		1	1	STD
	5TJ-14916-DR	.NEEDLE (#DUR)	1	1	1	AP
	5TJ-14916-DS	.NEEDLE (#DUS)	1	1	1	AP
	5TJ-14916-D1	.NEEDLE (#DUQ)	1			AP
	5TJ-14916-DU	.NEEDLE (#DUU)	1			AP
	5TJ-14916-DV	.NEEDLE (#DUV)	1			AP
	5TJ-14916-DW	.NEEDLE (#DUW)	1			AP
	5TJ-14916-DM	.NEEDLE (#DUM)		1	1	AP
	5TJ-14916-DN	.NEEDLE (#DUN)		1	1	AP
	5TJ-14916-DP	.NEEDLE (#DUP)		1	1	AP
	5TJ-14916-DT	.NEEDLE (#DUT)		1	1	AP
14	3TJ-14159-40	.CLIP	1	1	1	
15	5JG-14521-00	.SCREW, ADJUST	1	1	1	

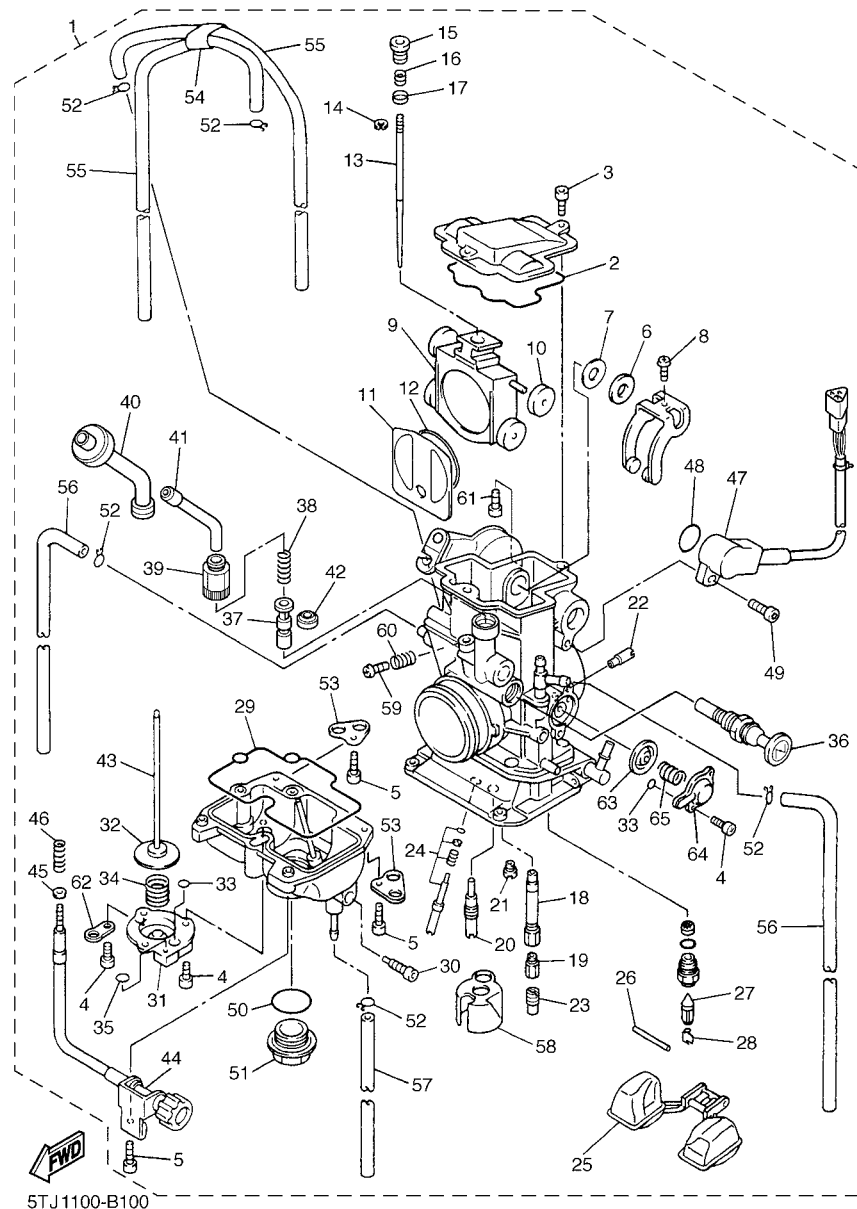

5TJ1100-B100

FIG. 10 CARBURETOR

REF. NO.	PART NO.	DESCRIPTION	5TJ1	5TJ2	5TJ4	REMARKS
16	5JG-14275-00	.SPRING	1	1	1	
17	5JG-14264-00	.COLLAR	1	1	1	
18	5JG-14947-00	.NOZZLE, MAIN	1	1	1	
19	4MX-14943-37	.JET, MAIN (#150)	1			STD
	4MX-14943-39	.JET, MAIN (#160)		1	1	STD
	4MX-14943-35	.JET, MAIN (#140)	1			AP
	4MX-14943-86	.JET, MAIN (#142)	1			AP
	4MX-14943-36	.JET, MAIN (#145)	1			AP
	4MX-14943-87	.JET, MAIN (#148)	1			AP
	4MX-14943-37	.JET, MAIN (#150)		1	1	AP
	4MX-14943-88	.JET, MAIN (#152)	1	1	1	AP
	4MX-14943-38	.JET, MAIN (#155)	1	1	1	AP
	4MX-14943-89	.JET, MAIN (#158)	1	1	1	AP
	4MX-14943-39	.JET, MAIN (#160)	1			AP
	4MX-14943-90	.JET, MAIN (#162)		1	1	AP
	4MX-14943-40	.JET, MAIN (#165)		1	1	AP
	4MX-14943-91	.JET, MAIN (#168)		1	1	AP
	4MX-14943-41	.JET, MAIN (#170)		1	1	AP
20	4MX-14948-05	.JET, SLOW (#45)	1			STD
	4MX-14948-06	.JET, SLOW (#48)		1	1	STD
	4MX-14948-03	.JET, SLOW (#40)	1			AP
	4MX-14948-04	.JET, SLOW (#42)	1	1	1	AP
	4MX-14948-06	.JET, SLOW (#48)	1			AP
	4MX-14948-05	.JET, SLOW (#45)		1	1	AP
	4MX-14948-07	.JET, SLOW (#50)	1	1	1	AP
	4MX-14948-08	.JET, SLOW (#52)		1	1	AP
21	3TJ-1494F-13	.JET (#65)	1	1	1	STD

B15

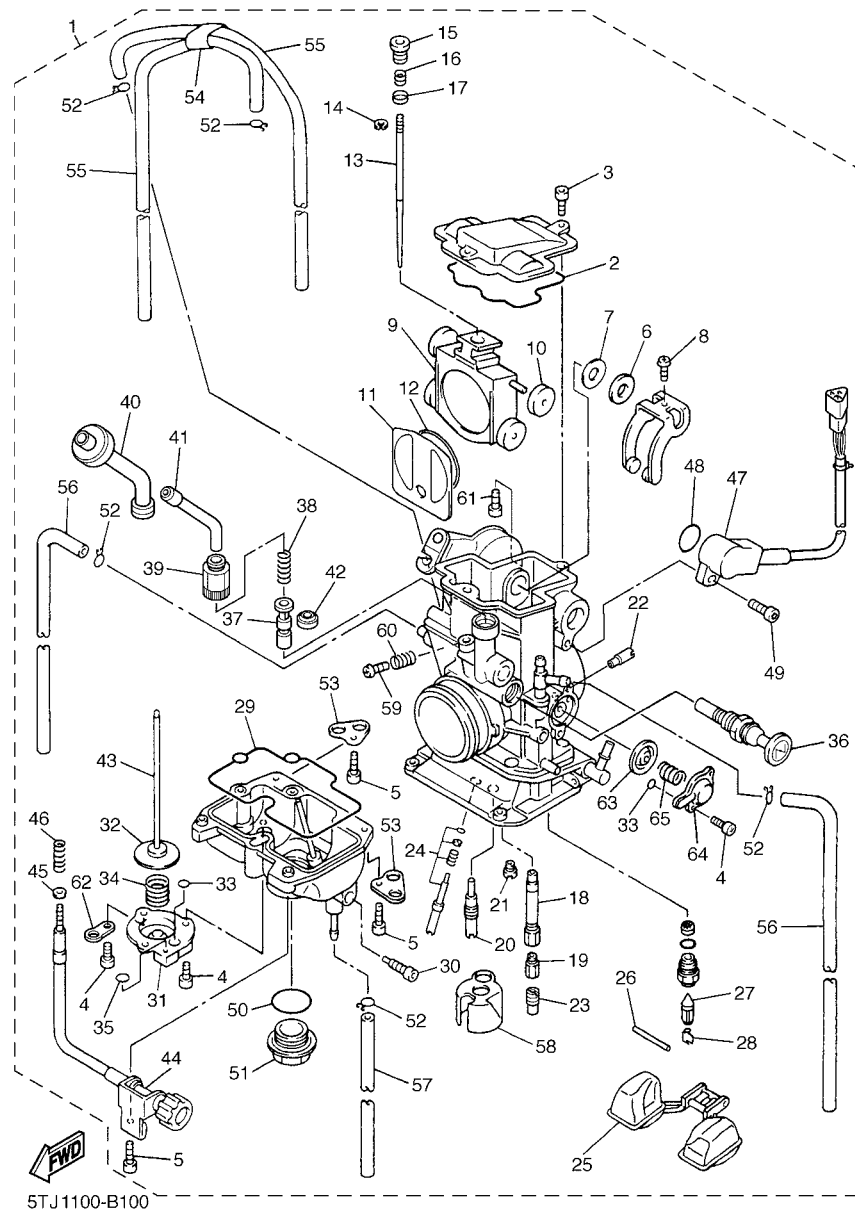

5TJ1100-B100

FIG. 10 CARBURETOR

REF. NO.	PART NO.	DESCRIPTION	5TJ1	5TJ2	5TJ4	REMARKS
21	3TJ-1494F-10	.JET (#58)	1	1	1	AP
	3TJ-1494F-11	.JET (#60)	1	1	1	AP
	3TJ-1494F-12	.JET (#62)	1	1	1	AP
	3TJ-1494F-14	.JET (#68)	1	1	1	AP
	3TJ-1494F-15	.JET (#70)	1	1	1	AP
22	5TA-14943-21	.JET, MAIN (#85)	1			
	5TA-14943-19	.JET, MAIN (#80)		1	1	
23	4JT-1494F-15	.JET (#70)	1			
	4JT-1494F-07	.JET (#50)		1	1	
24	5NL-14105-00	.PILOT SCREW SET	1	1	1	
25	4SR-14985-00	.FLOAT	1	1	1	
26	676-14548-00	.PIN, FLOAT ARM	1	1	1	
27	4MX-14392-00	.VALVE, NEEDLE	1	1	1	
28	633-14159-00	.CLIP	1	1	1	
29	5JG-14984-00	.GASKET, FLOAT CHAMBER	1	1	1	
30	3TJ-14191-40	.PLUG, DRAIN	1	1	1	
31	3TJ-14293-40	.COVER 1	1	1	1	
32	5JG-14940-18	.DIAPHRAGM ASSY	1	1	1	STD
	5JG-14940-17	.DIAPHRAGM ASSY	1	1	1	AP
	5JG-14940-19	.DIAPHRAGM ASSY	1	1	1	AP
33	3TJ-14536-40	.GASKET	2	2	2	
34	5GS-14933-40	.SPRING, DIAPHRAGM	1	1	1	
35	6H4-14561-00	.O-RING	1	1	1	
36	5TA-14171-00	.PLUNGER, STARTER	1	1	1	
37	5TA-14371-00	.PLUNGER, STARTER	1	1	1	
38	5TA-14335-00	.SPRING, PLUNGER	1	1	1	
39	5TA-14991-00	.SCREW	1	1	1	

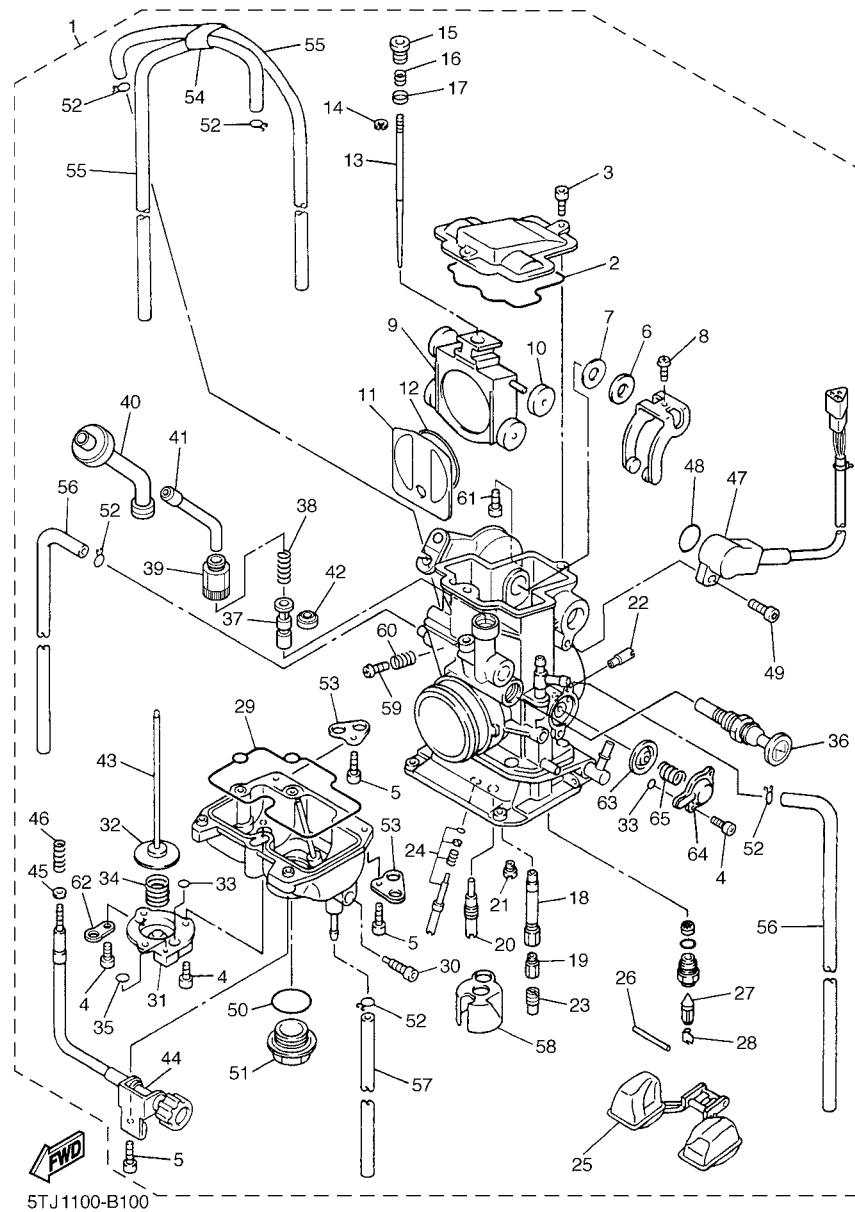

5TJ1100-B100

FIG. 10 CARBURETOR

REF. NO.	PART NO.	DESCRIPTION	5TJ1	5TJ2	5TJ4	REMARKS
40	5TA-14374-00	.CAP, PLUNGER	1	1	1	
41	5TA-14155-00	.GUIDE, CABLE	1	1	1	
42	5TA-14997-00	.SEAL	1	1	1	
43	5JG-14379-00	.ROD, STARTER	1	1	1	
44	5JG-14922-00	.SCREW, THROTTLE	1	1	1	
45	90201-08410	.WASHER, PLATE	1	1	1	
46	5TA-14934-00	.SPRING, THROTTLE STOP	1	1	1	
47	5TA-85885-00	.THROTTLE SENSOR ASSY	1	1	1	
48	5NX-14562-00	.O-RING	1	1	1	
49	5NX-14216-00	.SCREW	1	1	1	
50	4MX-14561-00	.O-RING	1	1	1	
51	4MX-14115-00	.PLUG, SCREW	1	1	1	
52	3TJ-14137-40	.CLIP	5	5	5	
53	5BE-14146-00	.PLATE	2	2	2	
54	5TA-14261-00	.HOLDER	1	1	1	
55	5TA-14196-00	.PIPE	2	2	2	
56	5TA-14197-00	.PIPE	2	2	2	
57	5TJ-14987-00	.HOSE	1	1	1	
58	5JG-14346-00	.PLATE	1	1	1	
59	5JG-14565-00	.SCREW	1	1	1	
60	5JG-14531-00	.SPRING, ADJUST SCREW	1	1	1	
61	5TJ-14591-00	.SCREW	1			
	5JG-14591-00	.SCREW		1	1	
62	5PA-14146-00	.PLATE	1	1	1	
63	5GS-14940-00	.DIAPHRAGM ASSY	1	1	1	
64	5GS-14958-00	.COVER, DIAPHRAGM	1	1	1	
65	5GS-14933-00	.SPRING, DIAPHRAGM	1	1	1	

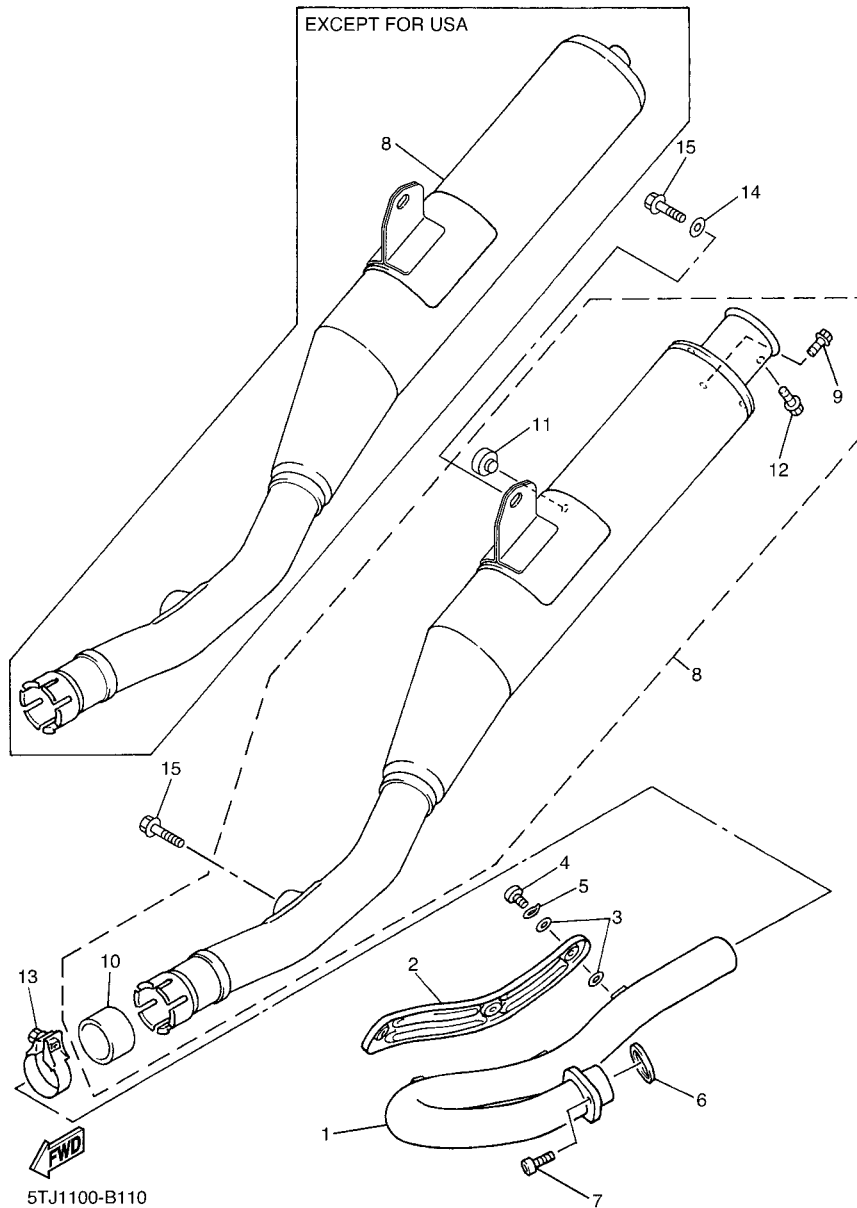
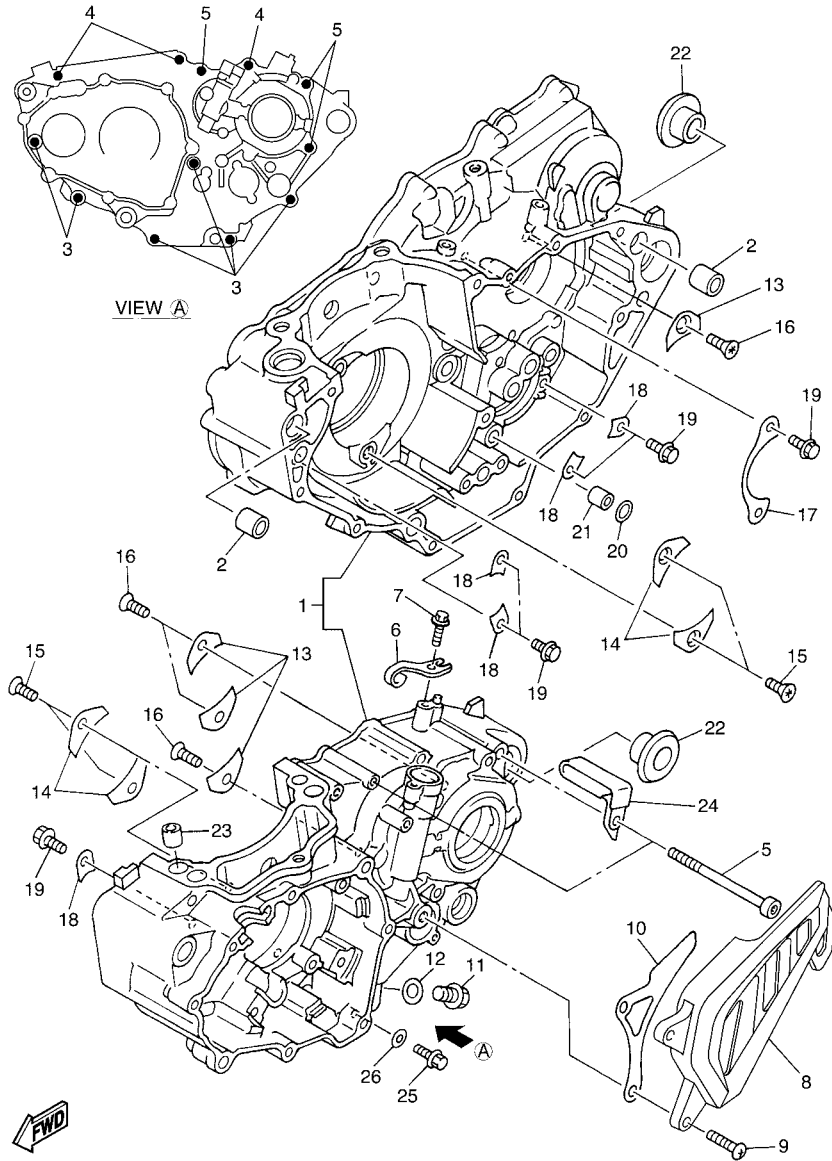

FIG. 11 EXHAUST

REF. NO.	PART NO.	DESCRIPTION	5TJ1	5TJ2	5TJ4	REMARKS
1	5TA-14611-00	PIPE, EXHAUST 1	1	1	1	
2	5TA-14628-00	PROTECTOR, EXHAUST PIPE	1	1	1	
3	4BD-14766-00	WASHER, PROTECTOR	6	6	6	
4	98980-06008	SCREW, BIND	3	3	3	
5	90206-06090	WASHER, WAVE	3	3	3	
6	3VD-14613-01	GASKET, EXHAUST PIPE	1	1	1	
7	91317-08020	BOLT	1	1	1	
8	5TJ-14710-00	MUFFLER ASSY 1	1			
	5TJ-14710-10	MUFFLER ASSY 1		1	1	
9	95804-06010	.BOLT, FLANGE	3			
10	3GW-14714-00	.GASKET, MUFFLER	1	1	1	
11	4FU-24181-00	.DAMPER, LOCATING 1	1	1	1	
12	95804-06016	.BOLT, FLANGE	1			
13	5BE-14788-00	BAND, SILENCER	1	1	1	
14	90201-086P8	WASHER, PLATE	1	1	1	
15	95817-08020	BOLT, FLANGE	2	2	2	



5TA1100-B120

FIG. 12 CRANKCASE

REF. NO.	PART NO.	DESCRIPTION	5TJ1	5TJ2	5TJ4	REMARKS
1	5TJ-15150-00	CRANKCASE ASSY	1	1	1	
2	99530-14016	PIN, DOWEL	2	2	2	
3	91317-06050	BOLT	6	6	6	
4	91317-06060	BOLT	3	3	3	
5	91317-06075	BOLT	3	3	3	
6	5TA-15441-00	HOLDER, CLUTCH CABLE	1	1	1	
7	95027-06016	BOLT, FLANGE	1	1	1	
8	5TA-15421-00	COVER, CRANKCASE 2	1	1	1	
9	98507-06025	SCREW, PAN HEAD	2	2	2	
10	5TA-17466-00	GUIDE, CHAIN	1	1	1	
11	95027-10016	BOLT, FLANGE	1	1	1	
12	90430-10188	GASKET	1	1	1	
13	4JT-15381-01	PLATE, BEARING COVER	4	4	4	
14	5BE-15383-01	PLATE, BEARING COVER	4	4	4	
15	90149-06126	SCREW	4	4	4	
16	90149-06326	SCREW	4	4	4	
17	4L0-17471-00	PLATE, COVER	1	1	1	
18	5DH-18562-00	PLATE, STOPPER 2	5	5	5	
19	90105-06553	BOLT, FLANGE	7	7	7	
20	93210-10197	O-RING	1	1	1	
21	99530-10114	PIN, DOWEL	1	1	1	
22	90387-18007	COLLAR	2	2	2	
23	99530-10116	PIN, DOWEL	2	2	2	
24	90461-10136	CLAMP	1	1	1	
25	95024-06010	BOLT, FLANGE	1	1	1	
26	90430-06014	GASKET	1	1	1	

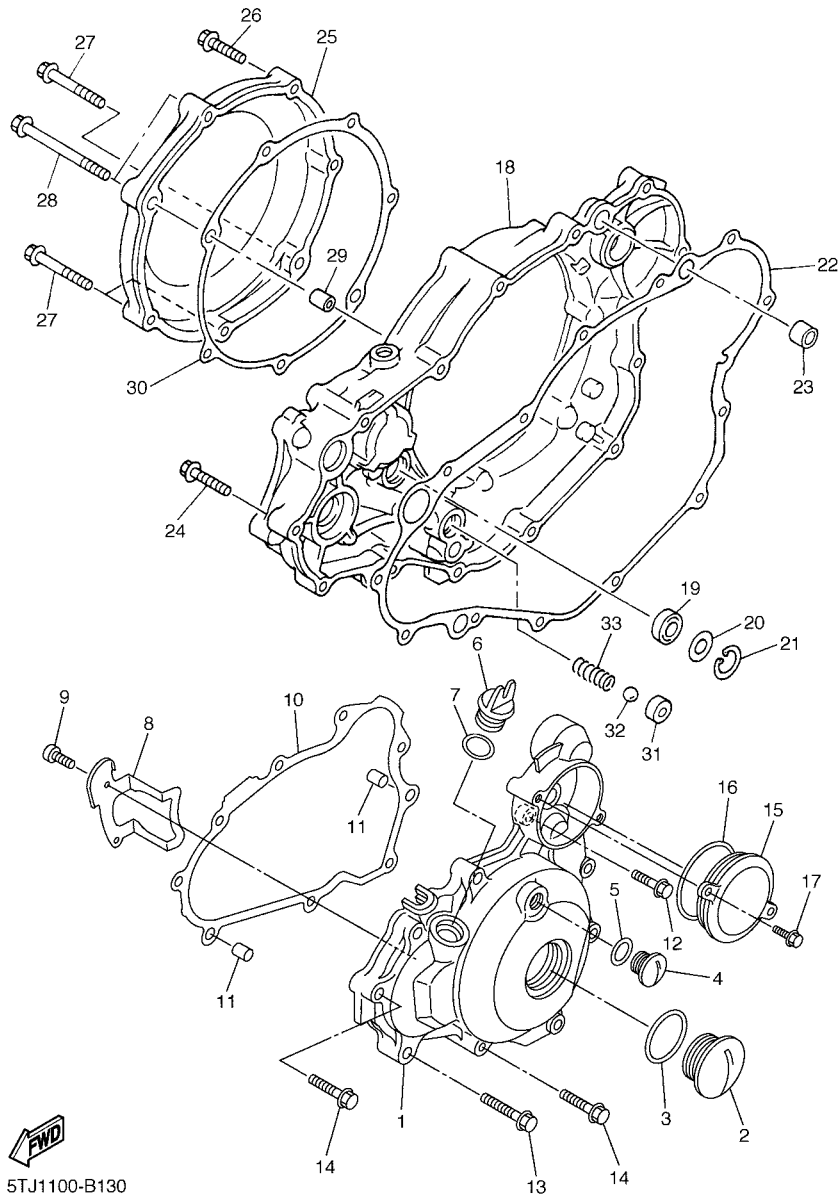

5TJ1100-B130

FIG. 13 CRANKCASE COVER 1

REF. NO.	PART NO.	DESCRIPTION	5TJ1	5TJ2	5TJ4	REMARKS
1	5TJ-15411-00	COVER, CRANKCASE 1	1	1	1	
2	90340-27002	PLUG, STRAIGHT SCREW	1	1	1	
3	93210-27370	O-RING	1	1	1	
4	90340-14128	PLUG, STRAIGHT SCREW	1	1	1	
5	93210-14369	O-RING	1	1	1	
6	3Y1-15363-00	PLUG, OIL	1	1	1	
7	93210-19123	O-RING	1	1	1	
8	90465-10017	CLAMP	1	1	1	
9	91317-05012	BOLT	2	2	2	
10	5TJ-15451-00	GASKET, CRANKCASE COVER 1	1	1	1	
11	99530-08016	PIN, DOWEL	2	2	2	
12	95027-06020	BOLT, FLANGE	1	1	1	
13	95027-06040	BOLT, FLANGE	2	2	2	
14	95027-06030	BOLT, FLANGE	6	6	6	
15	5TJ-15423-00	COVER 2	1	1	1	
16	93210-57428	O-RING	1	1	1	
17	95027-06016	BOLT, FLANGE	2	2	2	
18	5TA-15431-00	COVER, CRANKCASE 3	1	1	1	
19	93101-14164	OIL SEAL	1	1	1	
20	90201-15701	WASHER, PLATE (T=1.0)	1	1	1	
21	99009-22500	CIRCLIP	1	1	1	
22	5TA-15462-00	GASKET, CRANKCASE COVER 3	1	1	1	
23	91812-16001	PIN, DOWEL	2	2	2	
24	95027-06030	BOLT, FLANGE	10	10	10	
25	5TA-15415-00	COVER, GENERATOR	1	1	1	
26	95027-06030	BOLT, FLANGE	2	2	2	
27	95027-06040	BOLT, FLANGE	3	3	3	

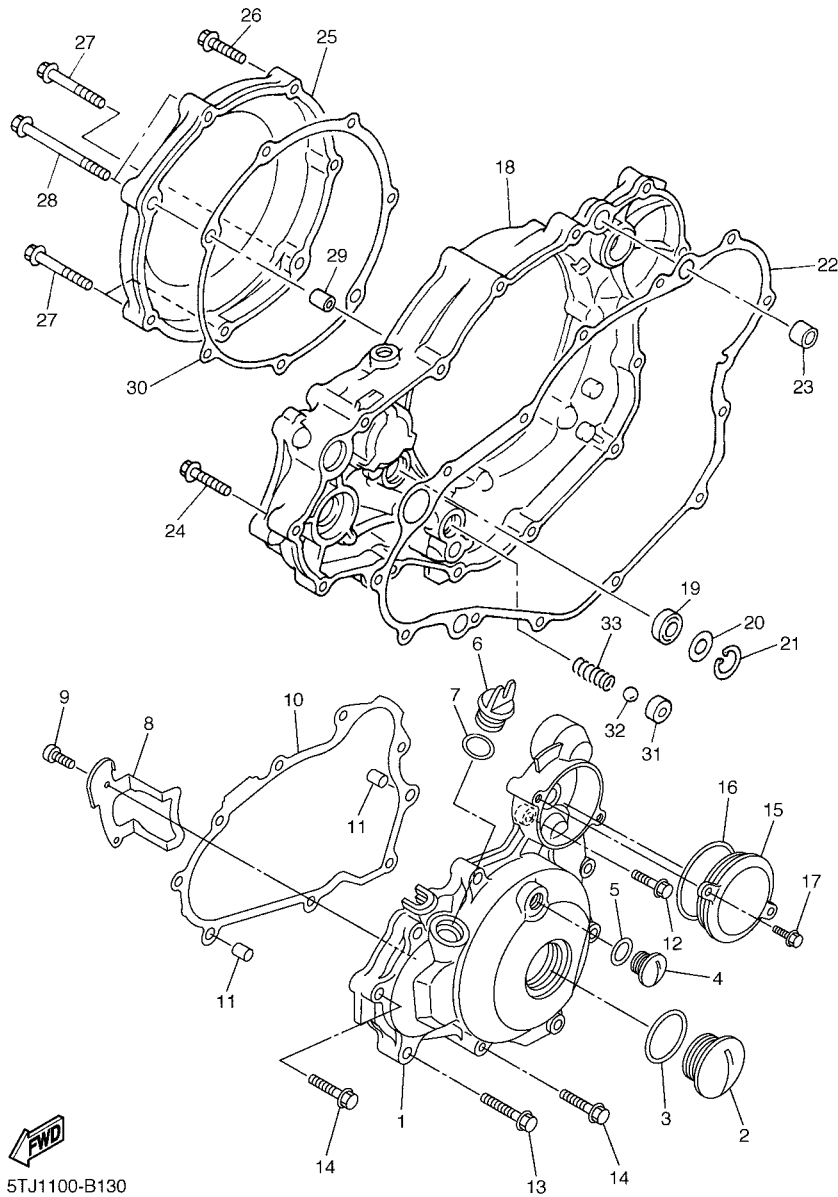

5TJ1100-B130

FIG. 13 CRANKCASE COVER 1

REF. NO.	PART NO.	DESCRIPTION	5TJ1	5TJ2	5TJ4	REMARKS
28	95027-06080	BOLT, FLANGE	2	2	2	
29	99530-08016	PIN, DOWEL	2	2	2	
30	5TA-15453-00	GASKET	1	1	1	
31	583-13113-00	SEAT, CHECK BALL	1	1	1	
32	93503-08007	BALL	1	1	1	
33	90501-043E0	SPRING, COMPRESSION	1	1	1	

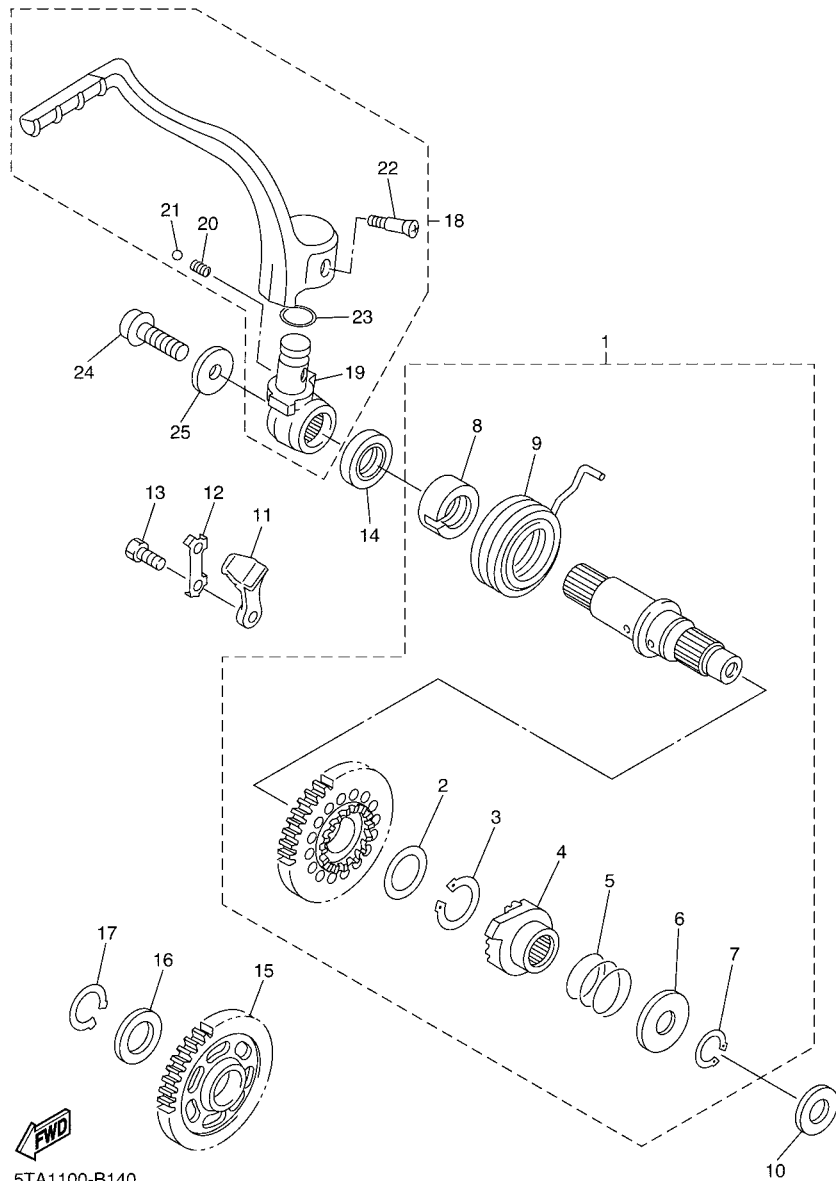
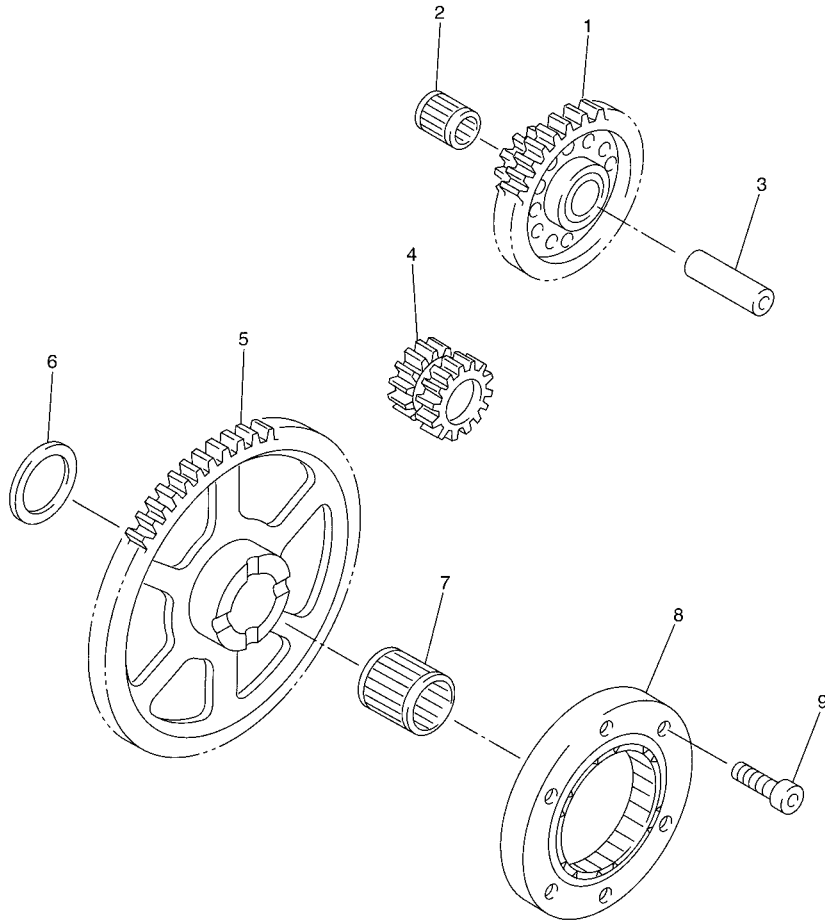

FIG. 14 STARTER

REF. NO.	PART NO.	DESCRIPTION	5TJ1	5TJ2	5TJ4	REMARKS
1	5TA-15601-00	KICK SHAFT ASSY	1	1	1	
2	90201-20685	.WASHER, PLATE (T=0.5)	1	1	1	
3	93410-20038	.CIRCLIP	1	1	1	
4	4GY-15671-00	.WHEEL, RATCHET	1	1	1	
5	90501-16016	.SPRING, COMPRESSION	1	1	1	
6	90201-167P7	.WASHER, PLATE	1	1	1	
7	99009-16400	.CIRCLIP	1	1	1	
8	5NL-15664-00	.GUIDE, SPRING	1	1	1	
9	90508-30743	.SPRING, TORSION	1	1	1	
10	90201-162H4	WASHER, PLATE	1	1	1	
11	5SG-15668-00	STOPPER	1	1	1	
12	214-15686-00	WASHER, LOCK	1	1	1	
13	90101-06001	BOLT	2	2	2	
14	93102-18278	OIL SEAL	1	1	1	
15	5TA-15651-00	GEAR, KICK IDLE	1	1	1	
16	90201-20276	WASHER, PLATE (T=1.0)	1	1	1	
17	99009-20400	CIRCLIP	1	1	1	
18	5TA-15620-01	KICK CRANK ASSY	1	1	1	
19	5TA-15621-01	.BOSS, KICK CRANK	1	1	1	
20	90501-147A5	.SPRING, COMPRESSION	1	1	1	
21	93507-32009	.BALL	1	1	1	
22	90152-06010	.SCREW, COUNTERSUNK	1	1	1	
23	93210-17570	.O-RING	1	1	1	
24	90109-082G0	BOLT	1	1	1	
25	90201-08326	WASHER, PLATE	1	1	1	

FIG. 15 STARTER CLUTCH



REF. NO.	PART NO.	DESCRIPTION	5TJ1	5TJ2	5TJ4	REMARKS
1	5TJ-15512-00	GEAR, IDLER 1	1	1	1	
2	93310-212R6	BEARING	2	2	2	
3	4GY-15521-00	SHAFT 1	2	2	2	
4	5TJ-15517-00	GEAR, IDLER 2	1	1	1	
5	5TJ-15515-00	GEAR 3	1	1	1	
6	90201-20272	WASHER, PLATE	1	1	1	
7	93310-22037	BEARING	1	1	1	
8	5TJ-15590-00	STARTER ONE-WAY ASSY	1	1	1	
9	90110-06004	BOLT, HEXAGON SOCKET HEAD	6	6	6	



5TJ1100-B150

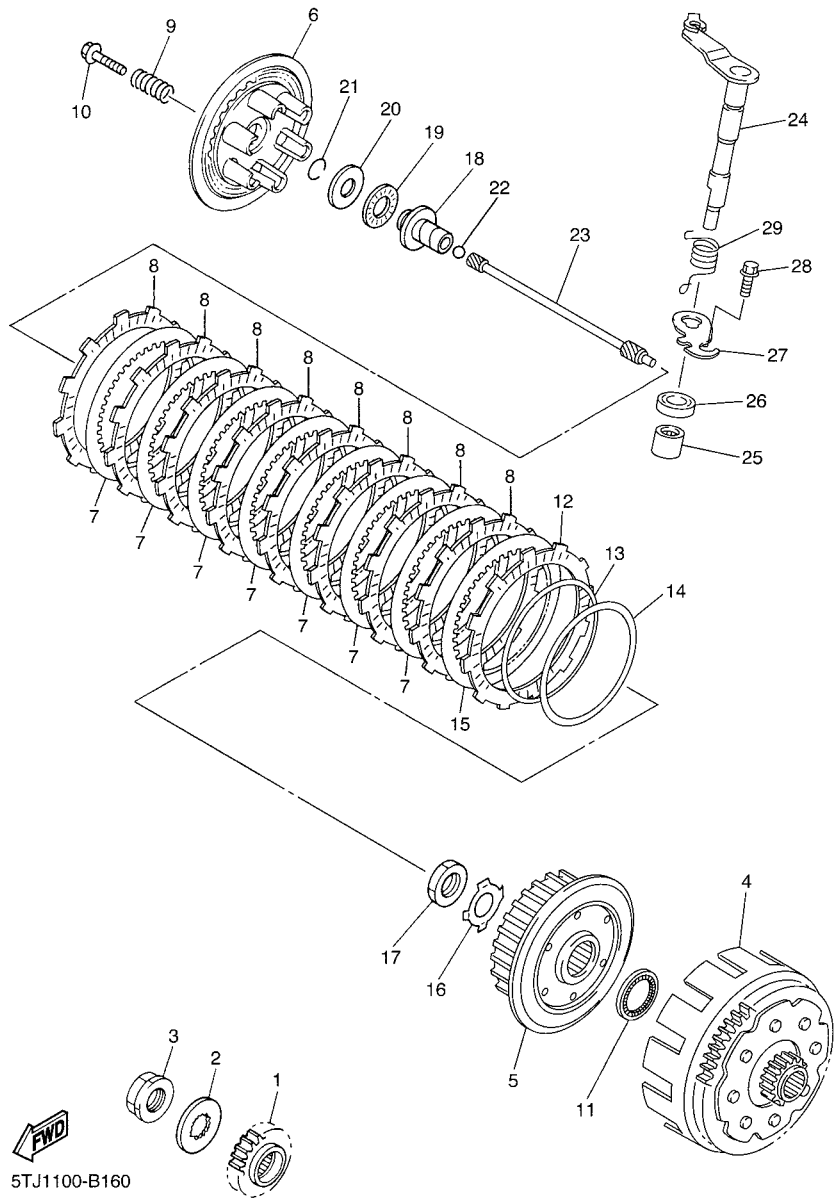

FIG. 16 CLUTCH

REF. NO.	PART NO.	DESCRIPTION	5TJ1	5TJ2	5TJ4	REMARKS
1	5TA-16111-00	GEAR, PRIMARY DRIVE	1	1	1	
2	90215-21001	WASHER, LOCK	1	1	1	
3	90179-20001	NUT	1	1	1	
4	5TA-16150-11	PRIMARY DRIVEN GEAR COMP.	1	1	1	
5	5TA-16371-00	BOSS, CLUTCH	1	1	1	
6	5JG-16351-00	PLATE, P <small>RE</small> SSURE 1	1	1	1	
7	5JG-16325-00	PLATE, CLUTCH 2	7	7	7	
8	5TA-16321-00	PLATE, FRICTION	8	8	8	
9	90501-22003	SPRING, COMPRESSION	6	6	6	
10	90159-06092	SCREW, WITH WASHER	6	6	6	
11	5TA-16154-00	PLATE, THRUST 1	1	1	1	
12	5JG-16321-00	PLATE, FRICTION	1	1	1	
13	5JG-16383-00	SPRING, CLUTCH BOSS	1	1	1	
14	5JG-16384-00	PLATE, SEAT	1	1	1	
15	5TJ-16325-00	PLATE, CLUTCH 2	1	1	1	
16	90215-20231	WASHER, LOCK	1	1	1	
17	90170-20327	NUT	1	1	1	
18	5JG-16356-00	ROD, PUSH 1	1	1	1	
19	93340-21505	BEARING	1	1	1	
20	90201-125L6	WASHER, PLATE	1	1	1	
21	93440-10085	C <small>IR</small> CLIP	1	1	1	
22	93511-32027	BALL	1	1	1	
23	5TA-16357-00	ROD, PUSH 2	1	1	1	
24	5TJ-16381-00	PUSH LEVER COMP.	1	1	1	
25	93317-11287	BEARING	1	1	1	
26	93102-12224	OIL SEAL	1	1	1	
27	5TA-16384-00	PLATE, SEAT	1	1	1	

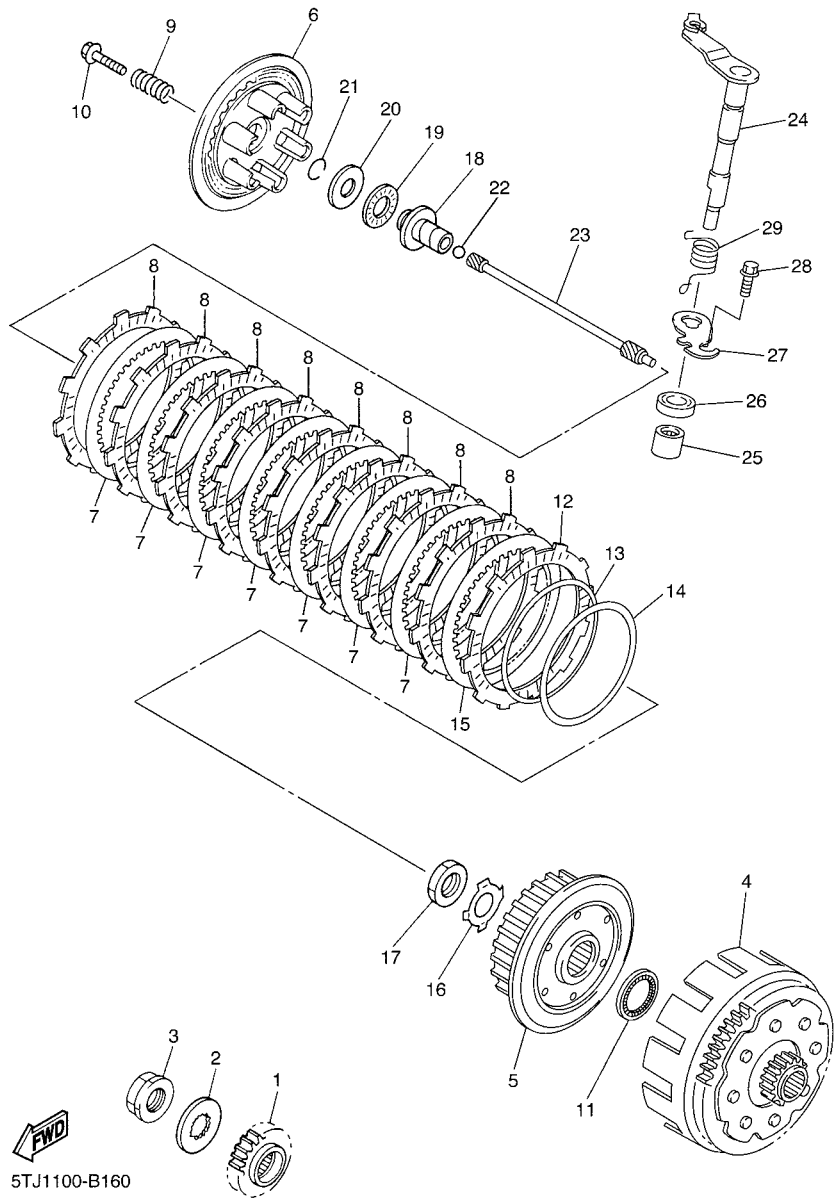
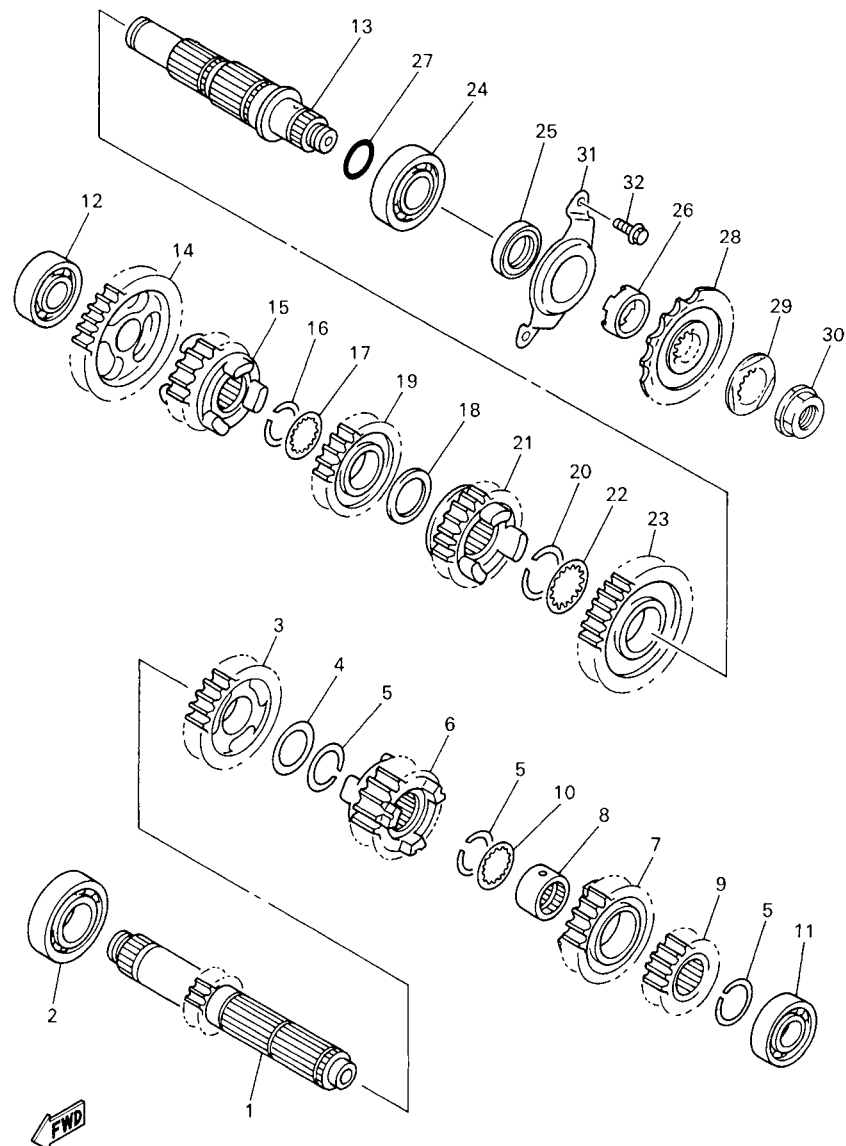

FIG. 16 CLUTCH

REF. NO.	PART NO.	DESCRIPTION	5TJ1	5TJ2	5TJ4	REMARKS
28	95027-06012	BOLT, FLANGE	1	1	1	
29	90508-14020	SPRING, TORSION	1	1	1	



5GS5100-0160

FIG. 17 TRANSMISSION

REF. NO.	PART NO.	DESCRIPTION	5TJ1	5TJ2	5TJ4	REMARKS
1	5TJ-17411-00	AXLE, MAIN (12T)	1	1	1	
2	93306-20532	BEARING	1	1	1	
3	5TJ-17151-00	GEAR, 5TH PINION (25T)	1	1	1	
4	90201-253K0	WASHER, PLATE (T=1.0)	1	1	1	
5	93440-25084	CIRCLIP	3	3	3	
6	5TJ-17131-00	GEAR, 3RD PINION (16T)	1	1	1	
7	5TJ-17141-00	GEAR, 4TH PINION (20T)	1	1	1	
8	90387-2113G	COLLAR	1	1	1	
9	5BF-17121-00	GEAR, 2ND PINION (15T)	1	1	1	
10	90209-21332	WASHER	1	1	1	
11	93306-00431	BEARING	1	1	1	
12	93306-00426	BEARING	1	1	1	
13	5BE-17402-00	DRIVE AXLE ASSY	1	1	1	
14	5BF-17211-00	GEAR, 1ST WHEEL (29T)	1	1	1	
15	5BF-17251-00	GEAR, 5TH WHEEL (21T)	1	1	1	
16	93440-25084	CIRCLIP	1	1	1	
17	90209-21332	WASHER	1	1	1	
18	90201-253K0	WASHER, PLATE (T=1.0)	1	1	1	
19	5TJ-17231-00	GEAR, 3RD WHEEL (21T)	1	1	1	
20	93440-28062	CIRCLIP	1	1	1	
21	5TJ-17241-00	GEAR, 4TH WHEEL (21T)	1	1	1	
22	90209-26348	WASHER	1	1	1	
23	5TJ-17221-00	GEAR, 2ND WHEEL (26T)	1	1	1	
24	93306-20593	BEARING	1	1	1	
25	93102-32480	OIL SEAL	1	1	1	
26	90387-2513F	COLLAR	1	1	1	
27	93210-22164	O-RING	1	1	1	

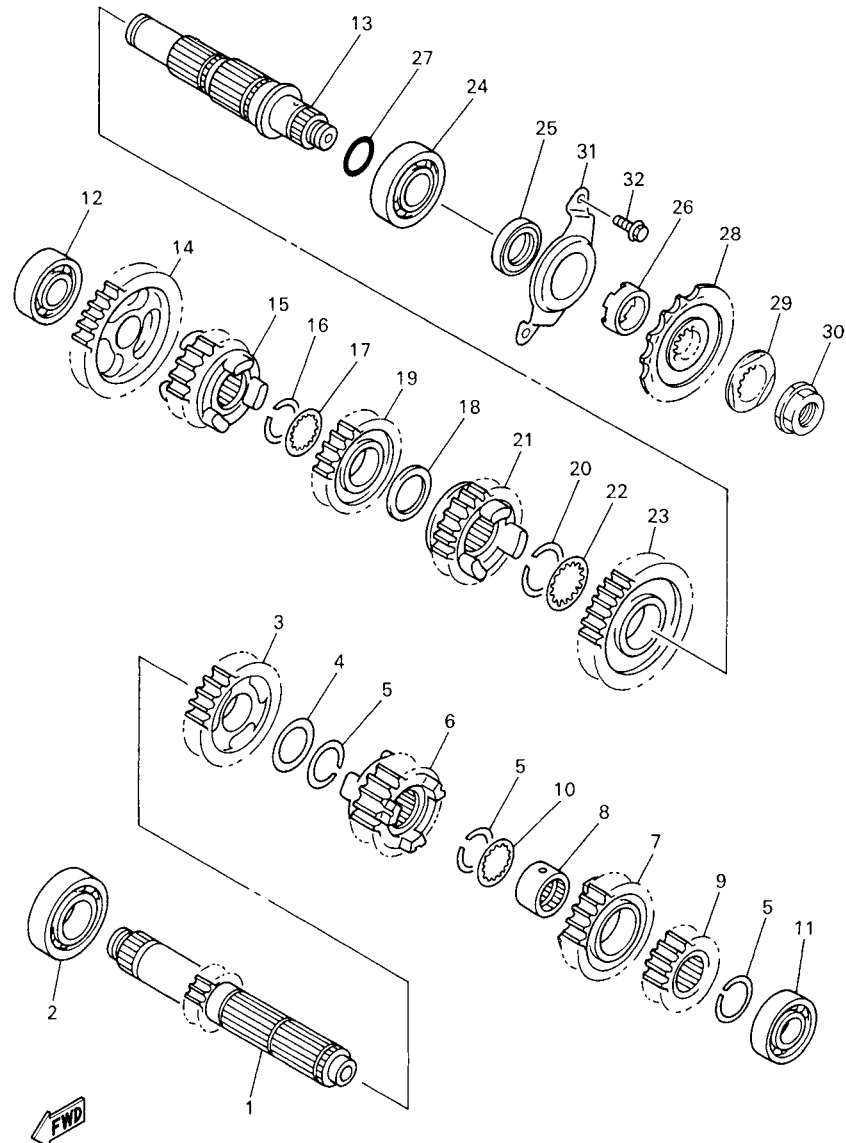

5GS5100-0160

FIG. 17 TRANSMISSION

REF. NO.	PART NO.	DESCRIPTION	5TJ1	5TJ2	5TJ4	REMARKS
28	5NG-17460-00	SPROCKET, DRIVE (14T)	1			STD
	9383E-14215	SPROCKET, DRIVE (14T)		1	1	STD
	9383E-15082	SPROCKET,DRIVE (15T)			1	AP FOR OCE
29	90215-21001	WASHER, LOCK	1	1	1	
30	90179-20001	NUT	1	1	1	
31	5GR-17471-00	PLATE, COVER	1	1	1	
32	90105-06553	BOLT, FLANGE	2	2	2	

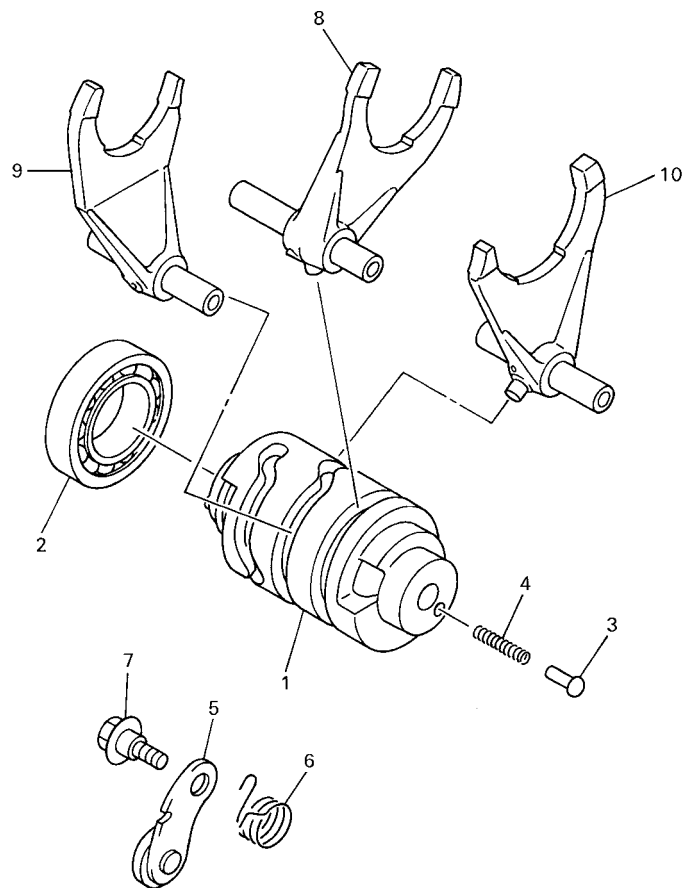

5BE100-8170

FIG. 18 SHIFT CAM. FORK

REF. NO.	PART NO.	DESCRIPTION	5TJ1	5TJ2	5TJ4	REMARKS
1	5NL-18541-00	CAM, SHIFT	1	1	1	
2	93306-90501	BEARING	1	1	1	
3	278-18542-00	POINT, NEUTRAL	1	1	1	
4	90501-06022	SPRING, COMPRESSION	1	1	1	
5	3XK-18140-00	STOPPER LEVER ASSY	1	1	1	
6	90508-26561	SPRING, TORSION	1	1	1	
7	90109-063F8	BOLT	1	1	1	
8	5BE-18501-00	FORK, SHIFT 1	1	1	1	
9	5BE-18502-10	FORK, SHIFT 2	1	1	1	
10	5BE-18503-00	FORK, SHIFT 3	1	1	1	

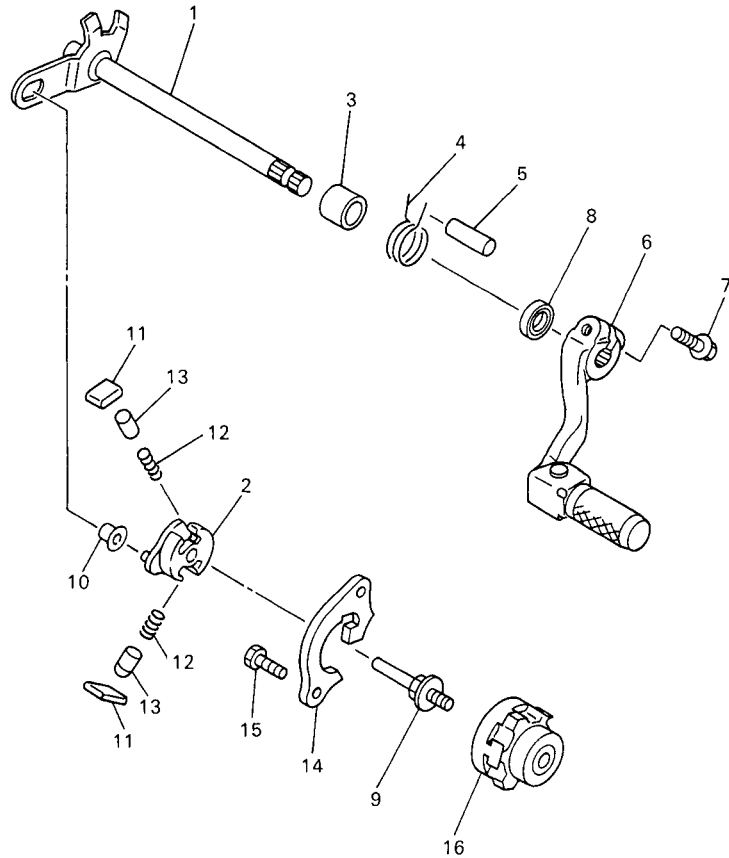

5NG1100-1180

FIG. 19 SHIFT SHAFT

REF. NO.	PART NO.	DESCRIPTION	5TJ1	5TJ2	5TJ4	REMARKS
1	5TA-18101-00	SHIFT SHAFT ASSY	1	1	1	
2	5LP-18122-00	LEVER, SHIFT 2	1	1	1	
3	90387-124F4	COLLAR	1	1	1	
4	90508-291A8	SPRING, TORSION	1	1	1	
5	93608-33002	PIN, DOWEL	1	1	1	
6	5UL-18110-00	SHIFT PEDAL ASSY	1	1	1	
7	95027-06020	BOLT, FLANGE	1	1	1	
8	93102-12224	OIL SEAL	1	1	1	
9	3XJ-18173-00	PIN, SHIFT	1	1	1	
10	3XJ-18178-00	ROLLER, SHIFT LEVER	1	1	1	
11	3XJ-18182-00	PAWL, SHIFTER	2	2	2	
12	90501-052G5	SPRING, COMPRESSION	2	2	2	
13	3XJ-18184-00	PIN, PAWL	2	2	2	
14	5BE-18172-00	GUIDE, SHIFT	1	1	1	
15	90101-06664	BOLT	2	2	2	
16	4EW-18185-00	SEGMENT	1	1	1	

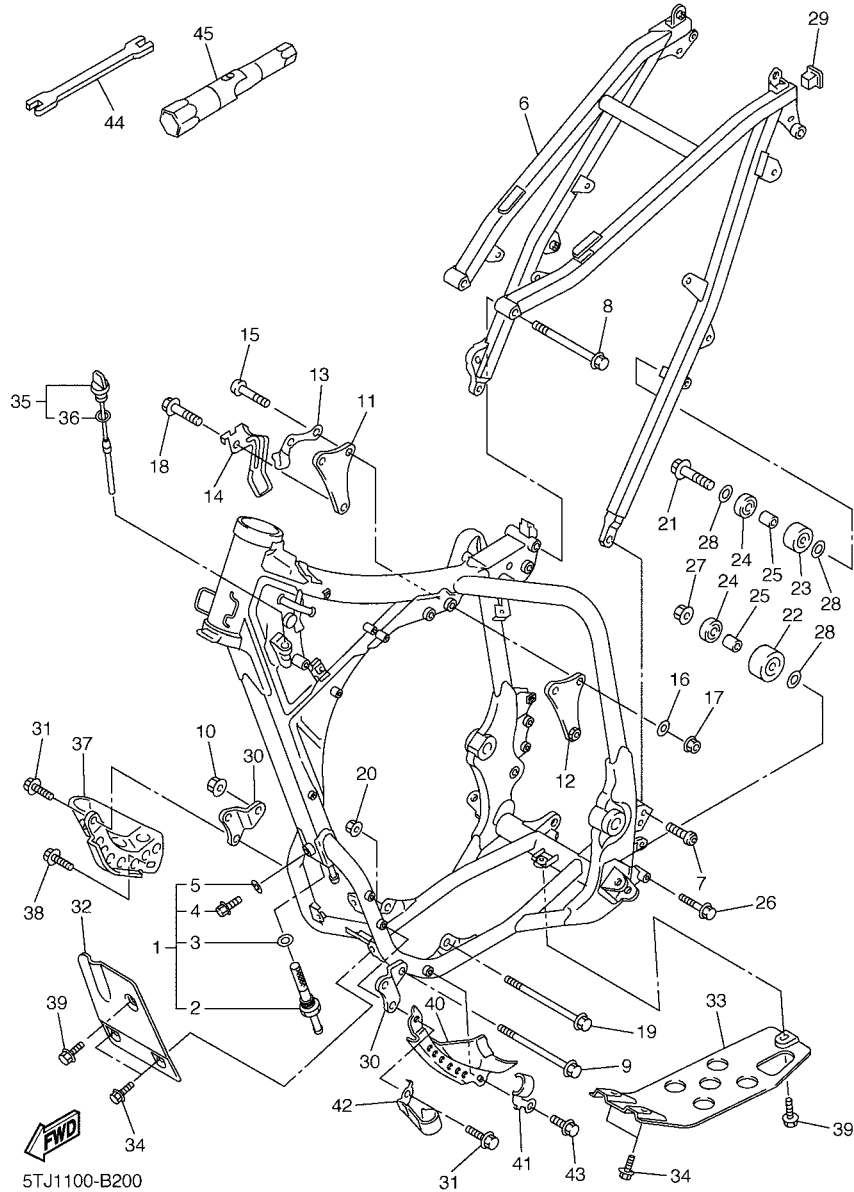

5TJ1100-B200

FIG. 20 FRAME

REF. NO.	PART NO.	DESCRIPTION	5TJ1	5TJ2	5TJ4	REMARKS
1	5TJ-21101-00	FRONT FRAME COMP.	1	1	1	
2	5TA-21756-00	.NET, FILTER	1	1	1	
3	90201-145M4	.WASHER, PLATE	1	1	1	
4	95827-08012	.BOLT, FLANGE	1	1	1	
5	90430-08119	.GASKET	1	1	1	
6	5TJ-21190-00	REAR FRAME COMP.	1	1	1	
7	90110-08096	BOLT, HEXAGON SOCKET HEAD	2	2	2	
8	90105-08120	BOLT, FLANGE	1	1	1	
9	95817-10160	BOLT, FLANGE	1	1	1	
10	90185-10002	NUT, SELF-LOCKING	1	1	1	
11	5TA-21425-00	BRACKET, REAR UPPER 1	1	1	1	
12	5TA-21425-10	BRACKET, REAR UPPER 1	1	1	1	
13	5TA-21161-00	HOLDER, CABLE	1	1	1	
14	5TJ-21335-00	CLAMP, WIRE HARNESS 1	1	1	1	
15	92017-10060	BOLT, BUTTON HEAD	2	2	2	
16	90201-104R2	WASHER, PLATE	3	3	3	
17	90179-10658	NUT	2	2	2	
18	95817-10055	BOLT, FLANGE	1	1	1	
19	90105-10733	BOLT, FLANGE	1	1	1	
20	90185-10002	NUT, SELF-LOCKING	1	1	1	
21	95027-08040	BOLT, FLANGE	1	1	1	
22	3JD-22178-10	TENSIONER	1	1	1	
23	4EW-22178-00	TENSIONER	1	1	1	
24	93300-60804	BEARING	2	2	2	
25	90387-086N4	COLLAR	2	2	2	
26	95027-08065	BOLT, FLANGE	1	1	1	
27	95707-08500	NUT, FLANGE	1	1	1	

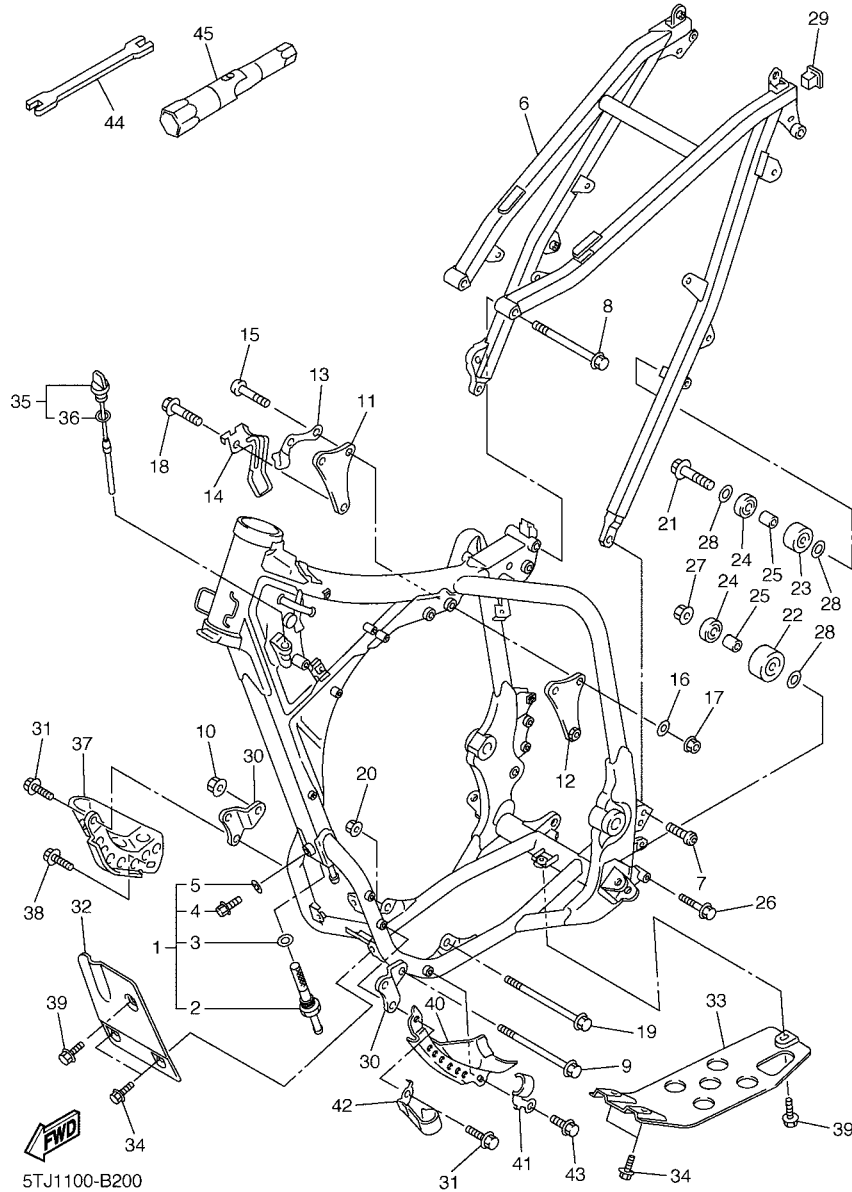

5TJ1100-B200

FIG. 20 FRAME

REF. NO.	PART NO.	DESCRIPTION	5TJ1	5TJ2	5TJ4	REMARKS
28	90201-086P8	WASHER, PLATE	3	3	3	
29	90338-18176	PLUG	1	1	1	
30	5TA-21417-00	BRACKET, FRONT LOWER 1	2	2	2	
31	95817-08016	BOLT, FLANGE	4	4	4	
32	5TA-21471-00	PROTECTOR, ENGINE	1	1	1	
33	5TA-2147E-00	GUARD, ENGINE 2	1	1	1	
34	95027-06012	BOLT, FLANGE	4	4	4	
35	5TA-15362-01	PLUG, OIL LEVEL	1	1	1	
36	93210-08001	.O-RING	1	1	1	
37	5TA-2147A-00	GUARD, ENGINE 1	1	1	1	
38	95027-08012	BOLT, FLANGE	1	1	1	
39	90119-06001	BOLT, WITH WASHER	2	2	2	
40	5TJ-2147F-00	GUARD, ENGINE 3	1	1	1	
41	5NG-21338-00	CLAMP	1	1	1	
42	5TJ-21338-00	CLAMP	1	1	1	
43	95027-08012	BOLT, FLANGE	1	1	1	
44	5ET-28166-00	WRENCH, HEXAGON	1	1	1	
45	5TA-2814F-00	BOX, SPARK PLUG	1	1	1	

FIG. 21 FENDER

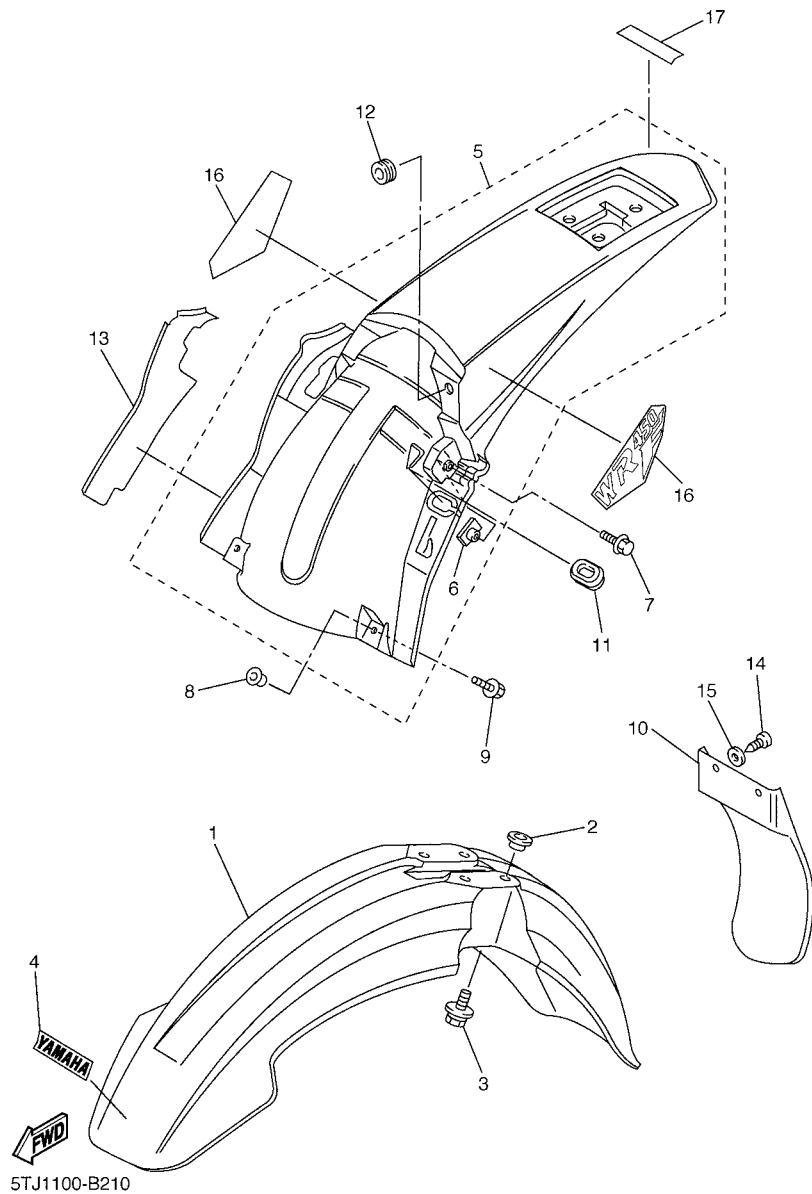

REF. NO.	PART NO.	DESCRIPTION				REMARKS
			5TJ1	5TJ2	5TJ4	
1	5HD-21511-00	FENDER, FRONT	1	1	1	
2	3JD-21748-00	COLLAR	4	4	4	
3	90119-06096	BOLT, WITH WASHER	4	4	4	
4	4ES-2153E-01	EMBLEM, YAMAHA	1	1	1	
5	5TJ-21610-00	REAR FENDER COMP.	1	1	1	
6	5TA-21635-00	.NUT, REAR FENDER	2	2	2	
7	90105-06154	BOLT, FLANGE	2	2	2	
8	90387-06009	COLLAR	2	2	2	
9	90119-06225	BOLT, WITH WASHER	2	2	2	
10	5TA-21642-00	GUARD, FLAP	1	1	1	
11	90480-01512	GROMMET	1	1	1	
12	90480-14532	GROMMET	1	1	1	
13	5TJ-2174T-00	INSULATOR, SIDE COVER 2	1	1	1	
14	97707-60016	SCREW, TAPPING	2	2	2	
15	90201-06557	WASHER, PLATE	2	2	2	
16	5TJ-2163G-00	EMBLEM 1	2	2	2	
17	4ES-2153E-01	EMBLEM, YAMAHA	1	1	1	

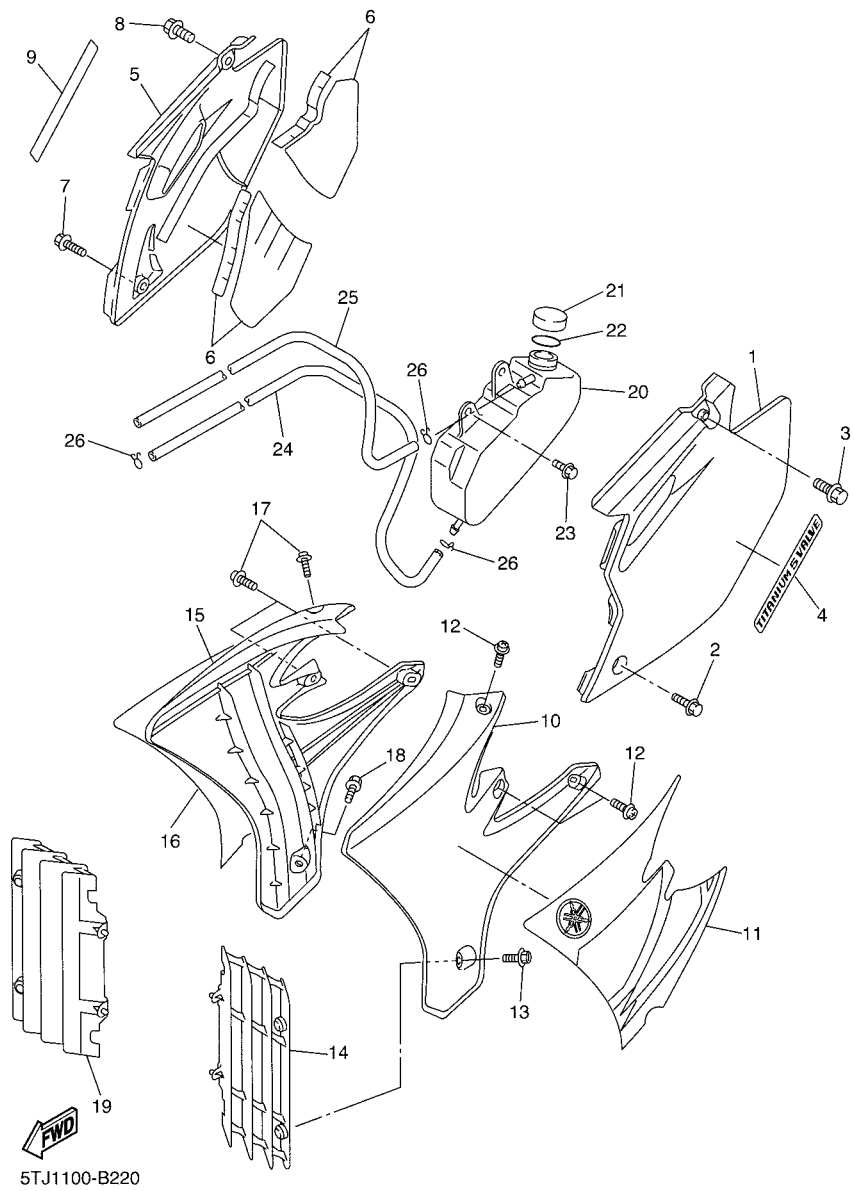
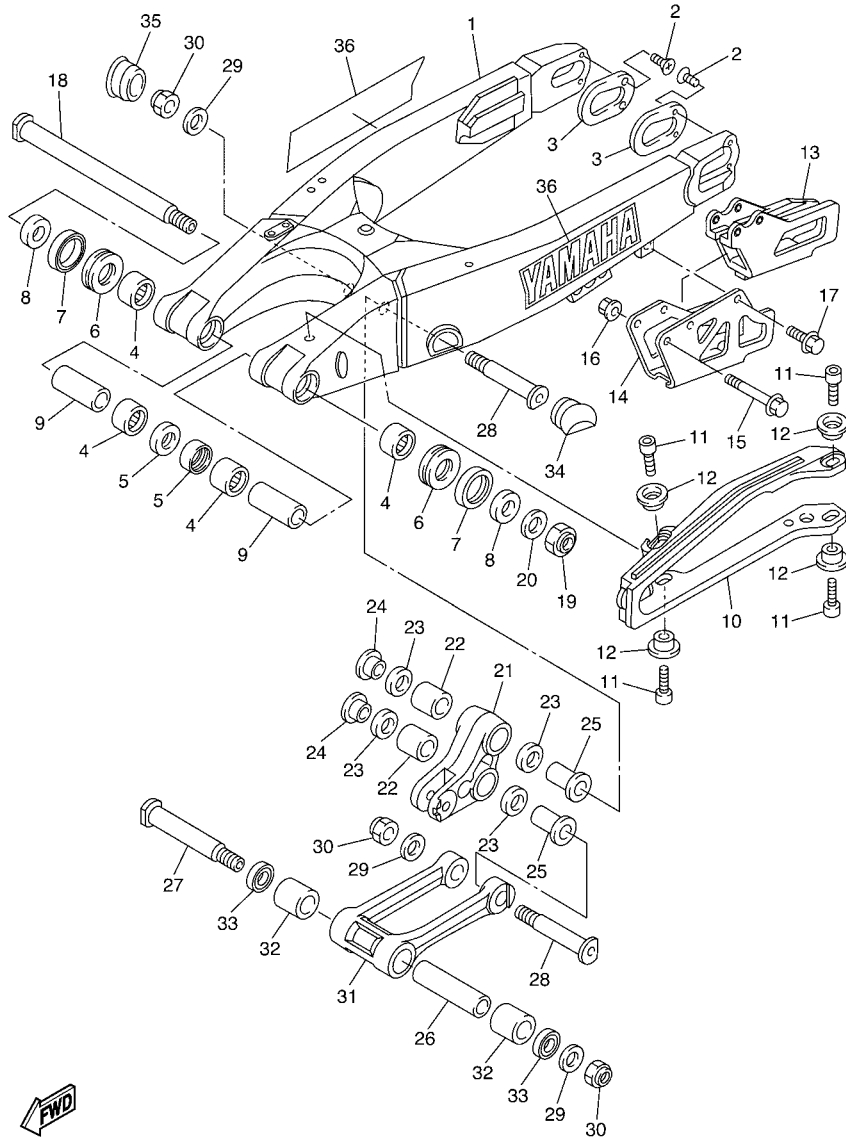

FIG. 22 SIDE COVER

REF. NO.	PART NO.	DESCRIPTION	5TJ1	5TJ2	5TJ4	REMARKS
1	5TJ-21711-00	COVER, SIDE 1	1	1	1	
2	95827-06016	BOLT, FLANGE	1	1	1	
3	90119-08238	BOLT, WITH WASHER	1	1	1	
4	5JG-21781-50	EMBLEM 1	1	1	1	
5	5TJ-21721-00	COVER, SIDE 2	1	1	1	
6	5TJ-2174A-00	INSULATOR, SIDE COVER	1	1	1	
7	95827-06016	BOLT, FLANGE	1	1	1	
8	90119-08238	BOLT, WITH WASHER	1	1	1	
9	5JG-21781-50	EMBLEM 1	1	1	1	
10	5TJ-21730-00	SIDE COVER ASSY 3	1	1	1	
11	5TJ-2173E-00	GRAPHIC 1	1	1	1	
12	90159-06182	SCREW, WITH WASHER	3	3	3	
13	90159-06078	SCREW, WITH WASHER	1	1	1	
14	5TJ-2172A-00	PANEL 1	1	1	1	
15	5TJ-21740-00	SIDE COVER ASSY 4	1	1	1	
16	5TJ-2173F-00	GRAPHIC 2	1	1	1	
17	90159-06182	SCREW, WITH WASHER	3	3	3	
18	90159-06078	SCREW, WITH WASHER	1	1	1	
19	5TJ-2172A-00	PANEL 1	1	1	1	
20	5GS-21871-00	TANK, RECOVERY	1	1	1	
21	26H-21875-00	CAP	1	1	1	
22	26H-21874-00	GASKET	1	1	1	
23	90119-06051	BOLT, WITH WASHER	2	2	2	
24	91A20-05140	TUBE, FLEXIBLE VINYL	1	1	1	
25	91A21-05125	TUBE, FLEXIBLE	1	1	1	
26	90467-09006	CLIP	3	3	3	



5TA1100-B220

FIG. 23 REAR ARM

REF. NO.	PART NO.	DESCRIPTION	5TJ1	5TJ2	5TJ4	REMARKS
1	5UN-22110-00	REAR ARM COMP.	1	1	1	
2	90151-04048	SCREW, COUNTERSUNK	4	4	4	
3	5UN-22355-00	PATCH	2	2	2	
4	93317-22262	BEARING	4	4	4	
5	93106-22019	OIL SEAL (DC 22-28-8)	2	2	2	
6	93342-22217	BEARING	2	2	2	
7	93109-28043	OIL SEAL	2	2	2	
8	90387-18005	COLLAR	2	2	2	
9	90387-18004	COLLAR	2	2	2	
10	5UN-22151-00	SEAL, GUARD	1	1	1	
11	91317-05008	BOLT	4	4	4	
12	5JG-22156-00	WASHER, PLATE	4	4	4	
13	5UN-22199-00	SUPPORT, CHAIN	1	1	1	
14	5UN-22128-00	COVER, THRUST 1	1	1	1	
15	95027-06050	BOLT, FLANGE	2	2	2	
16	90179-06568	NUT	2	2	2	
17	95027-06010	BOLT, FLANGE	1	1	1	
18	5NY-22141-01	SHAFT, PIVOT	1	1	1	
19	90185-16127	NUT, SELF-LOCKING	1	1	1	
20	90201-160F6	WASHER, PLATE	1	1	1	
21	5NY-2217A-00	ARM, RELAY	1	1	1	
22	93315-32056	BEARING	2	2	2	
23	93109-20076	OIL SEAL	4	4	4	
24	90387-16005	COLLAR	2	2	2	
25	90387-16007	COLLAR	2	2	2	
26	90387-167Y9	COLLAR	1	1	1	
27	5NY-22121-00	SHAFT 1	1	1	1	

D6

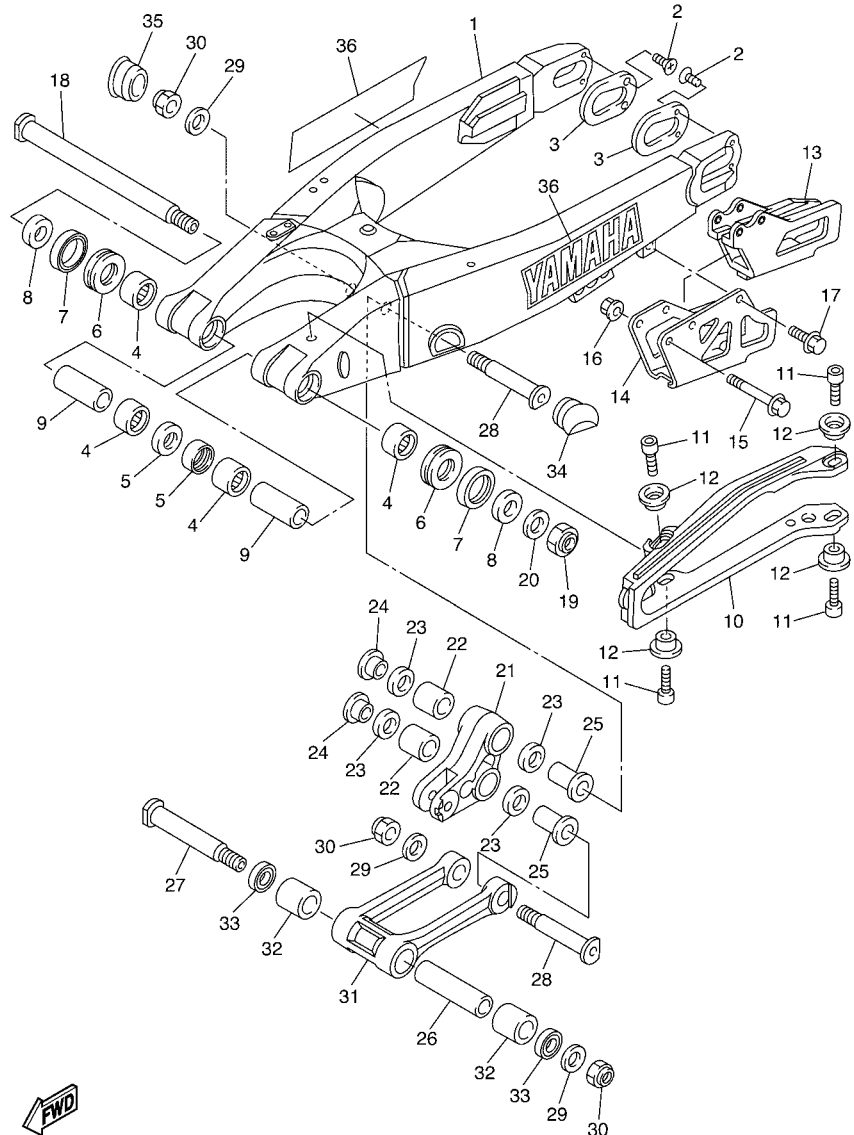

5TA1100-B220

FIG. 23 REAR ARM

REF. NO.	PART NO.	DESCRIPTION				REMARKS
			5TU1	5TU2	5TU4	
28	5NY-22122-00	SHAFT 2	2	2	2	
29	90201-14740	WASHER, PLATE	3	3	3	
30	90185-14007	NUT, SELF-LOCKING	3	3	3	
31	5NY-2217F-00	ROD, CONNECTING 1	1	1	1	
32	93315-32053	BEARING	2	2	2	
33	93109-20076	OIL SEAL	2	2	2	
34	5NY-2135F-00	COVER	1	1	1	
35	5HD-2135F-00	COVER	1	1	1	
36	5UN-2153A-00	EMBLEM, YAMAHA	2	2	2	

D7

FIG. 24 REAR SUSPENSION

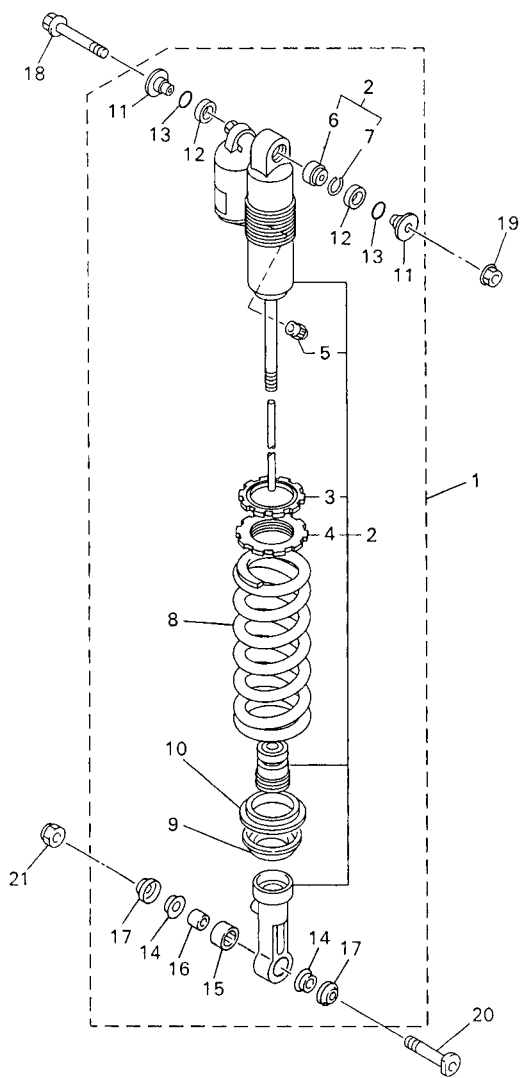

5SF1100-2230

REF. NO.	PART NO.	DESCRIPTION	5TJ1	5TJ2	5TJ4	REMARKS
1	5TJ-22210-00	SHOCK ABSORBER ASSY, REAR	1			
	5TJ-22210-10	SHOCK ABSORBER ASSY, REAR		1		
	5TJ-22210-30	SHOCK ABSORBER ASSY, REAR			1	UR FOR CAN
	5TJ-22210-40	SHOCK ABSORBER ASSY, REAR			1	UR FOR OCE,ZAF
2	5TJ-22201-00	.DAMPER SUB ASSY	1			
	5TJ-22201-10	.DAMPER SUB ASSY		1		
	5TJ-22201-30	.DAMPER SUB ASSY			1	UR FOR CAN
	5TJ-22201-40	.DAMPER SUB ASSY			1	UR FOR OCE,ZAF
3	3SP-22234-00	..GUIDE, SPRING 3	1	1	1	
4	3SP-22213-00	..SEAT, SPRING UPPER	1	1	1	
5	509-23184-L0	..CAP, AIR VALVE	1	1	1	
6	4JX-22226-00	..BUSH, SHOCK ABSORBER LOWER	1	1	1	
7	5DH-23183-00	..CIRCLIP	1	1	1	
8	5UN-22212-90	.SPRING (K=5.2)	1		1	UR FOR U49,CAN
	5UN-22212-30	.SPRING (K=4.9)			1	
	5UN-22212-50	.SPRING (K=5.3)			1	UR FOR OCE,ZAF
9	5DH-22214-00	.GUIDE, SPRING 1	1	1	1	
10	5MV-22224-00	.GUIDE, SPRING 2	1	1	1	
11	5DH-22253-00	.COLLAR, DISTANCE	2	2	2	
12	3JE-22475-00	.SEAL, DUST	2	2	2	
13	4EW-22474-00	.SEAL, RING	2	2	2	
14	5MV-22253-00	.COLLAR, DISTANCE	2	2	2	
15	5MV-22176-00	.BEARING	1	1	1	
16	5MV-22184-00	.BUSH	1	1	1	
17	5NY-22475-00	.SEAL, DUST	2	2	2	
18	90105-10323	BOLT, FLANGE	1	1	1	
19	95607-10200	NUT, SELF-LOCKING	1	1	1	

D8

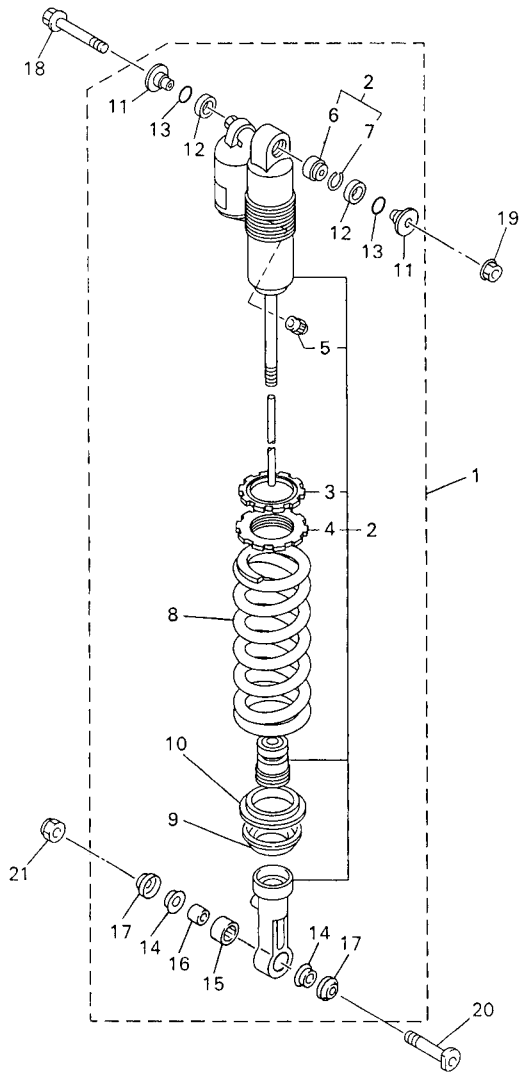

5SF1100-2230

FIG. 24 REAR SUSPENSION

REF. NO.	PART NO.	DESCRIPTION	5TJ1	5TJ2	5TJ4	REMARKS
20	5NY-22241-00	BOLT 1	1	1	1	
21	90185-10060	NUT, SELF-LOCKING	1	1	1	

D9

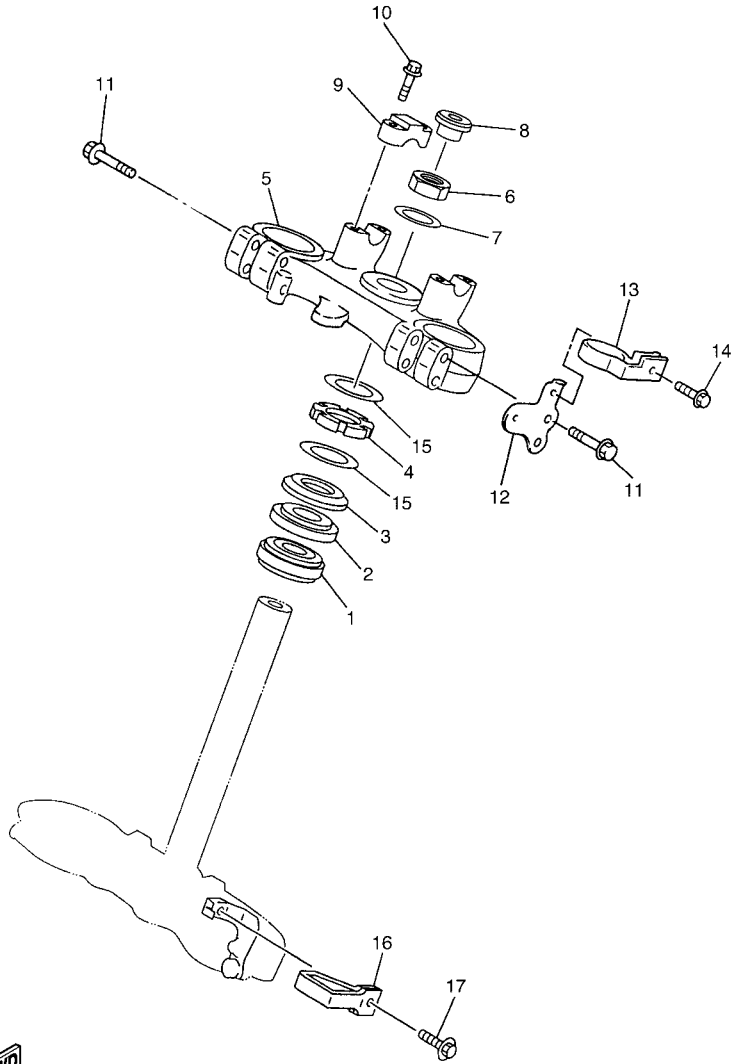

5TJ1100-B250

FIG. 25 STEERING

REF. NO.	PART NO.	DESCRIPTION	5TJ1	5TJ2	5TJ4	REMARKS
1	93332-00081	BEARING	1	1	1	
2	93332-00068	BEARING	1	1	1	
3	4EW-23416-00	COVER, BALL RACE 2	1	1	1	
4	90179-28650	NUT	1	1	1	
5	5PH-23435-00	CROWN, HANDLE	1	1	1	
6	90170-24373	NUT	1	1	1	
7	90201-247L2	WASHER, PLATE	1	1	1	
8	5TJ-2319U-00	CAP	1	1	1	
9	3SP-23441-00	HOLDER, HANDLE UPPER	2	2	2	
10	95027-08035	BOLT, FLANGE	4	4	4	
11	95027-08040	BOLT, FLANGE	4	4	4	
12	5TJ-2831V-00	STAY, HEAD LIGHT 1	1	1	1	
13	4GY-23389-00	GUIDE, CABLE	1	1	1	
14	90105-05361	BOLT, FLANGE	1	1	1	
15	90201-286K9	WASHER, PLATE	2	2	2	
16	4DA-23389-00	GUIDE, CABLE	1	1	1	
17	90119-05071	BOLT, WITH WASHER	1	1	1	

D10

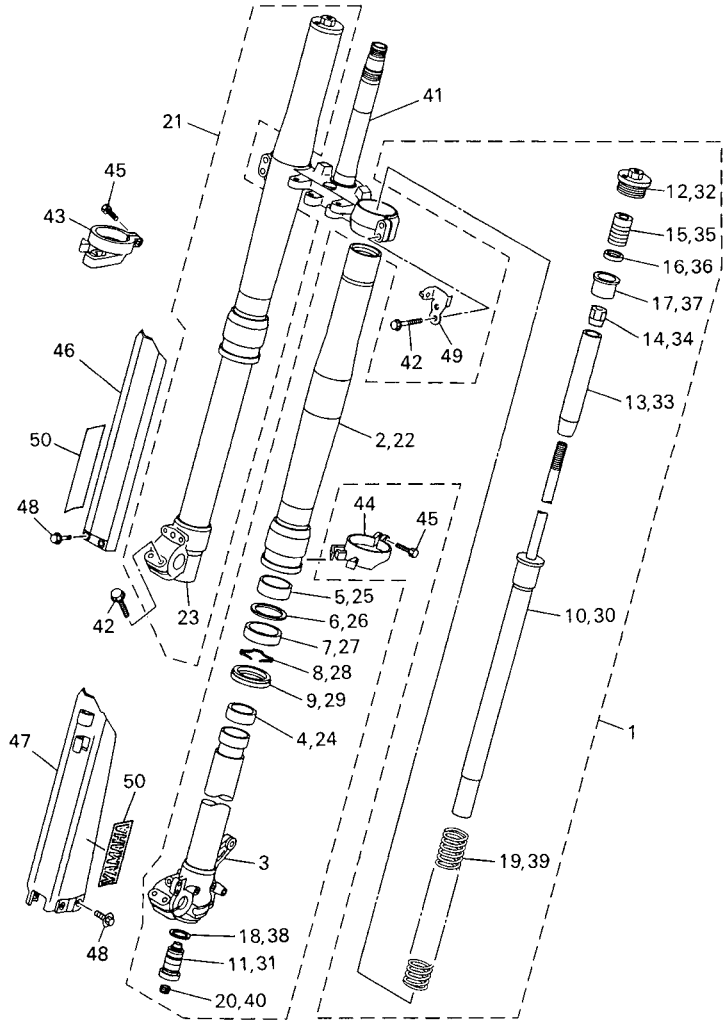

5JG5100-1250

FIG. 26 FRONT FORK

REF. NO.	PART NO.	DESCRIPTION	5TJ1	5TJ2	5TJ4	REMARKS
1	5TJ-23102-00	FRONT FORK ASSY (L.H)	1		1	UR FOR U49,CAN
	5TJ-23102-10	FRONT FORK ASSY (L.H)		1		
	5TJ-23102-40	FRONT FORK ASSY (L.H)			1	UR FOR OCE,ZAF
2	5TA-23136-L0	.TUBE, OUTER (RIGHT)	1	1	1	
3	5DH-23120-L0	.INNER TUBE COMP.2	1	1	1	
4	5ET-23171-L0	.PISTON, FRONT FORK	1	1	1	
5	5ET-23125-L0	.METAL, SLIDE 1	1	1	1	
6	5UN-23146-L0	.WASHER, OIL SEAL	1	1	1	
7	5UN-23145-L0	.OIL SEAL	1	1	1	
8	4SS-23153-L0	.RING, SNAP	1	1	1	
9	5HD-23144-L0	.SEAL, DUST	1	1	1	
10	5TJ-23170-L0	.CYLINDER COMP., FRONT FORK	1	1	1	
11	5TJ-2316A-L0	.VALVE COMP.	1		1	UR FOR U49,CAN
	5TJ-2316A-M0	.VALVE COMP.		1	1	UR FOR OCE,ZAF
12	5UN-23111-L0	.BOLT, CAP	1	1	1	
13	5DH-23142-L0	.SEAT, SPRING UPPER	1	1	1	
14	5HD-23393-L0	.NUT, SPECIAL	1	1	1	
15	5MV-23195-L0	.RUBBER	1	1	1	
16	5DH-23149-L0	.WASHER, SPRING UPPER	1	1	1	
17	5DH-23118-L0	.SPACER	1	1	1	
18	4SS-23158-L0	.GASKET	1	1	1	
19	5GR-23141-L0	.SPRING, FRONT FORK (K=0.46)	1		1	UR FOR U49,CAN
	4SR-23141-L0	.SPRING, FRONT FORK (K=0.42)		1		
	5NL-23141-00	.SPRING,FRONT FORK (K=0.44)			1	UR FOR OCE,ZAF
20	3JD-2312G-L0	.PLUG	1	1	1	
21	5TJ-23103-00	FRONT FORK ASSY (R.H)	1		1	UR FOR U49,CAN
	5TJ-23103-10	FRONT FORK ASSY (R.H)		1		

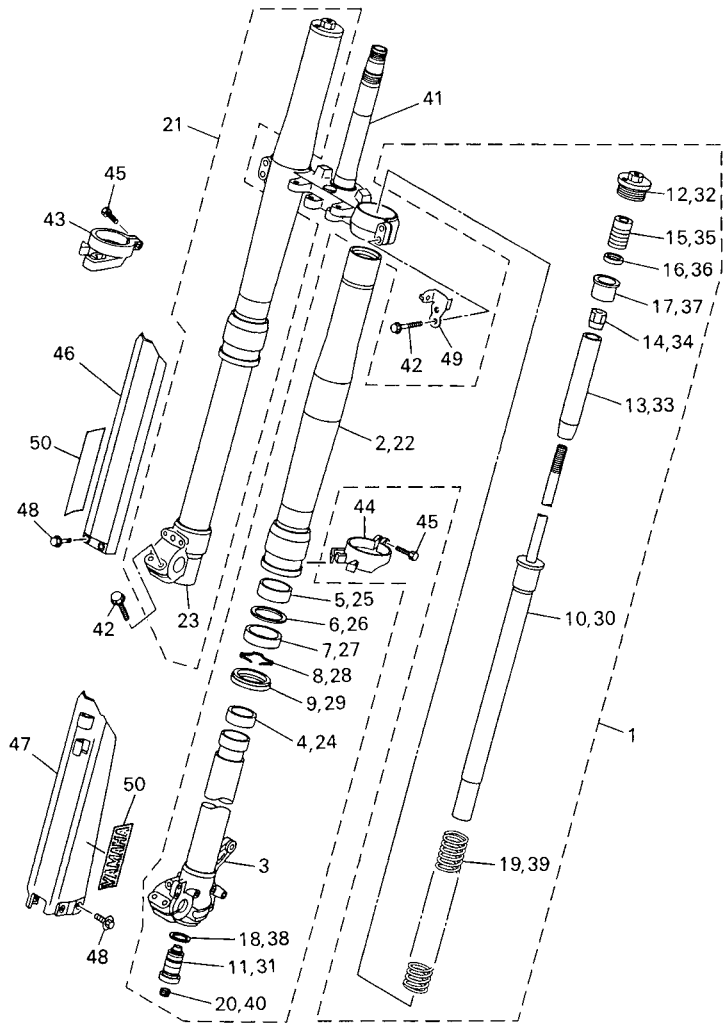

5JG5100-1250

FIG. 26 FRONT FORK

REF. NO.	PART NO.	DESCRIPTION	5TJ1	5TJ2	5TJ4	REMARKS
21	5TJ-23103-40	FRONT FORK ASSY (R.H)			1	UR FOR OCE,ZAF
22	5TA-23136-L0	.TUBE, OUTER (RIGHT)	1	1	1	
23	5BF-23110-L0	.INNER TUBE COMP.1	1	1	1	
24	5ET-23171-L0	.PISTON, FRONT FORK	1	1	1	
25	5ET-23125-L0	.METAL, SLIDE 1	1	1	1	
26	5UN-23146-L0	.WASHER, OIL SEAL	1	1	1	
27	5UN-23145-L0	.OIL SEAL	1	1	1	
28	4SS-23153-L0	.RING, SNAP	1	1	1	
29	5HD-23144-L0	.SEAL, DUST	1	1	1	
30	5TJ-23170-L0	.CYLINDER COMP., FRONT FORK	1	1	1	
31	5TJ-2316A-L0	.VALVE COMP.	1	1		UR FOR U49,CAN
	5TJ-2316A-M0	.VALVE COMP.		1	1	UR FOR OCE,ZAF
32	5UN-23111-L0	.BOLT, CAP	1	1	1	
33	5DH-23142-L0	.SEAT, SPRING UPPER	1	1	1	
34	5HD-23393-L0	.NUT, SPECIAL	1	1	1	
35	5MV-23195-L0	.RUBBER	1	1	1	
36	5DH-23149-L0	.WASHER, SPRING UPPER	1	1	1	
37	5DH-23118-L0	.SPACER	1	1	1	
38	4SS-23158-L0	.GASKET	1	1	1	
39	5GR-23141-L0	.SPRING, FRONT FORK (K=0.46)	1	1		UR FOR U49,CAN
	4SR-23141-L0	.SPRING, FRONT FORK (K=0.42)		1		
	5NL-23141-00	.SPRING,FRONT FORK (K=0.44)			1	UR FOR OCE,ZAF
40	3JD-2312G-L0	.PLUG	1	1	1	
41	5UP-23340-L0	UNDER BRACKET COMP.	1	1	1	
42	5NY-23346-L0	BOLT 1	8	8	8	
43	4SS-2314G-L0	PROTECTOR GUIDE COMP., 2	1	1	1	
44	5DH-2314F-L0	PROTECTOR GUIDE COMP., 1	1	1	1	

FIG. 26 FRONT FORK

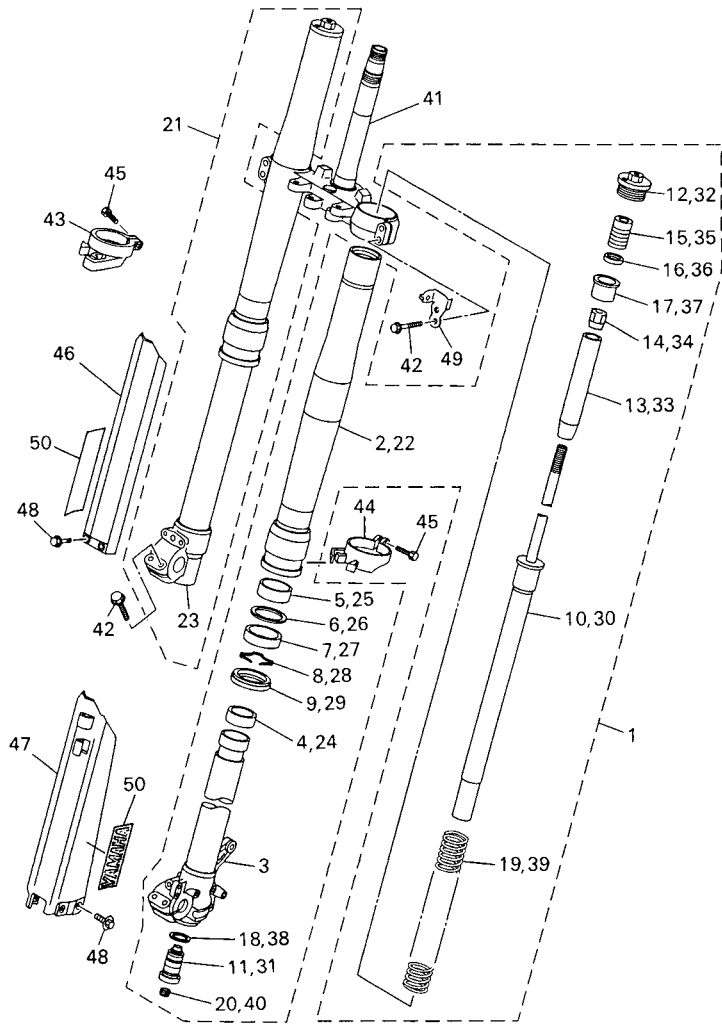

REF. NO.	PART NO.	DESCRIPTION	5TJ1	5TJ2	5TJ4	REMARKS
45	4SS-23346-L0	BOLT 1	2	2	2	
46	5TJ-2314J-00	PROTECTOR COMP., 2	1	1	1	
47	5TA-2314H-00	PROTECTOR COMP., 1	1	1	1	
48	3SP-23356-L0	BOLT 2	6	6	6	
49	5HC-2331E-00	GUIDE, CABLE	1	1	1	
50	4XL-2153A-10	EMBLEM, YAMAHA	2	2	2	



5JG5100-1250

D13

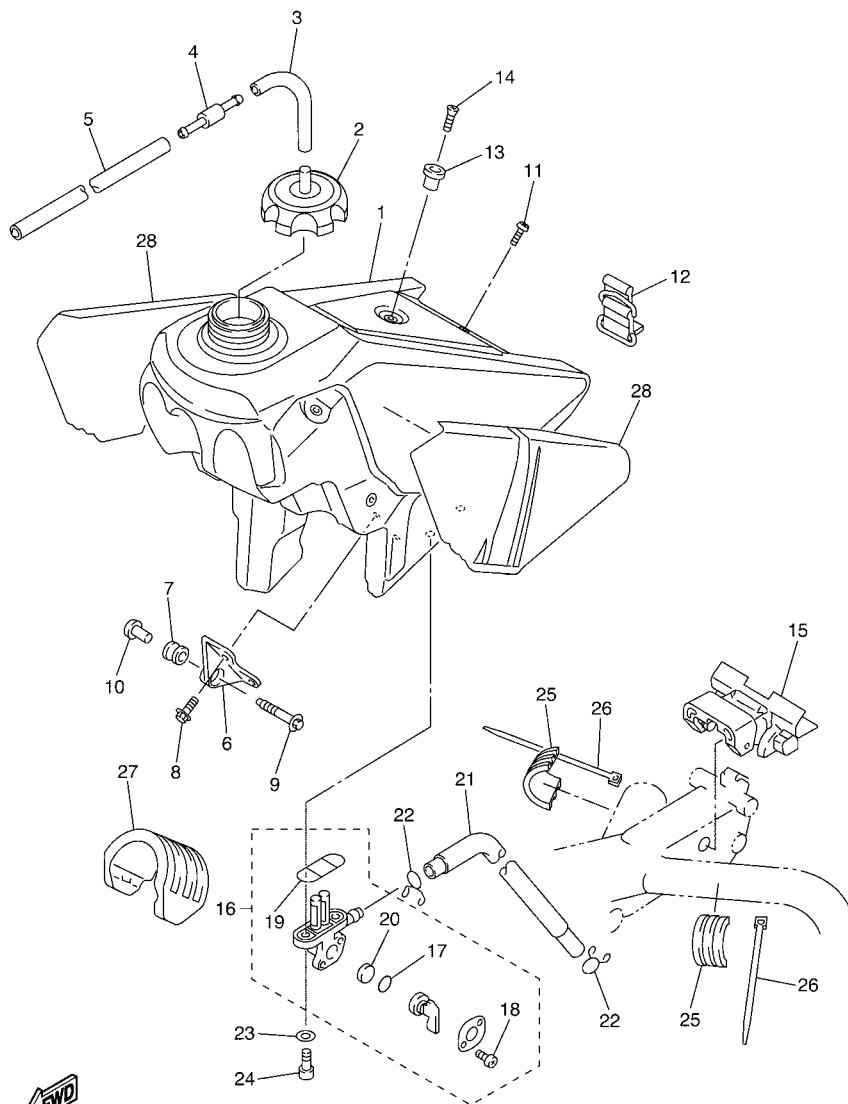

5TJ1100-B270

FIG. 27 FUEL TANK

REF. NO.	PART NO.	DESCRIPTION	5TJ1	5TJ2	5TJ4	REMARKS
1	5TJ-24110-00	FUEL TANK COMP.	1	1	1	
2	5NY-24610-00	CAP ASSY	1	1	1	
3	90445-09220	HOSE (L30)	1	1	1	
4	3XJ-24380-00	PIPE JOINT ASSY	1	1	1	
5	90445-09100	HOSE	1	1	1	
6	24X-24144-00	HOLDER, DAMPER	2	2	2	
7	90480-18549	GROMMET	2	2	2	
8	95027-06016	BOLT, FLANGE	4	4	4	
9	90119-06214	BOLT, WITH WASHER	2	2	2	
10	5NY-24186-00	WASHER, SPECIAL	2	2	2	
11	98907-06025	SCREW, BIND	1	1	1	
12	5SF-24173-00	BAND, TANK FITTING 1	1	1	1	
13	4EW-2412F-00	BRACKET, SEAT	1	1	1	
14	98707-06025	SCREW, FLAT HEAD	1	1	1	
15	5TJ-24181-00	DAMPER, LOCATING 1	1	1	1	
16	2GU-24500-01	FUEL COCK ASSY 1	1	1	1	
17	3AJ-24534-00	.SEAL, COCK	1	1	1	
18	97801-03008	.SCREW, PAN HEAD	2	2	2	
19	4X8-24512-00	.O-RING	1	1	1	
20	3AJ-24523-00	.VALVE PACKING	1	1	1	
21	90445-11185	HOSE	1	1	1	
22	90467-10008	CLIP	2	2	2	
23	90202-05193	WASHER, PLATE	2	2	2	
24	90149-06011	SCREW	2	2	2	
25	5NY-24183-00	DAMPER, LOCATING 3	2	2	2	
26	90465-13152	CLAMP	2	2	2	
27	5BE-24182-00	DAMPER, LOCATING 2	1	1	1	

FIG. 27 FUEL TANK

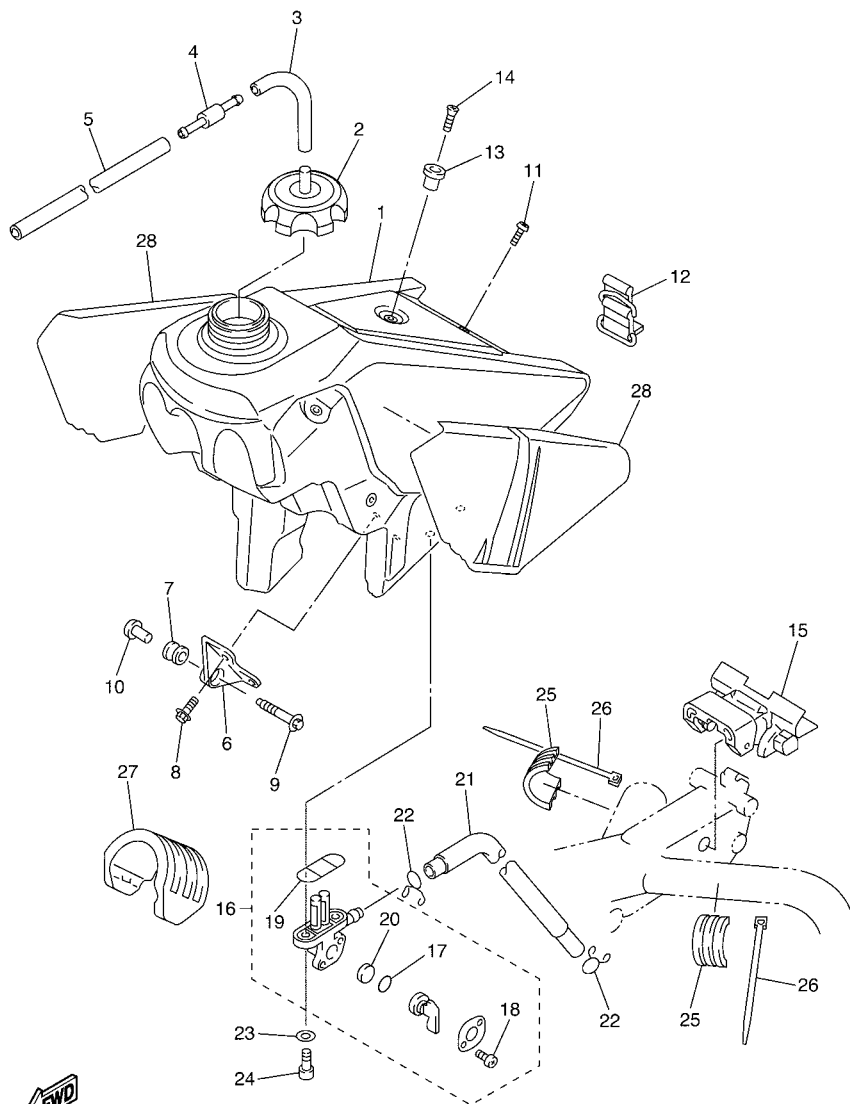

5TJ1100-B270

REF. NO.	PART NO.	DESCRIPTION	5TJ1	5TJ2	5TJ4	REMARKS
28	5TJ-24240-01	GRAPHIC SET	1	1	1	

FIG. 28 SEAT

REF. NO.	PART NO.	DESCRIPTION	5TJ1	5TJ2	5TJ4			REMARKS
1	5TJ-24710-00	SINGLE SEAT ASSY	1	1	1			
2	5TJ-2470F-00	.SEAT COVER COMP.	1	1	1			

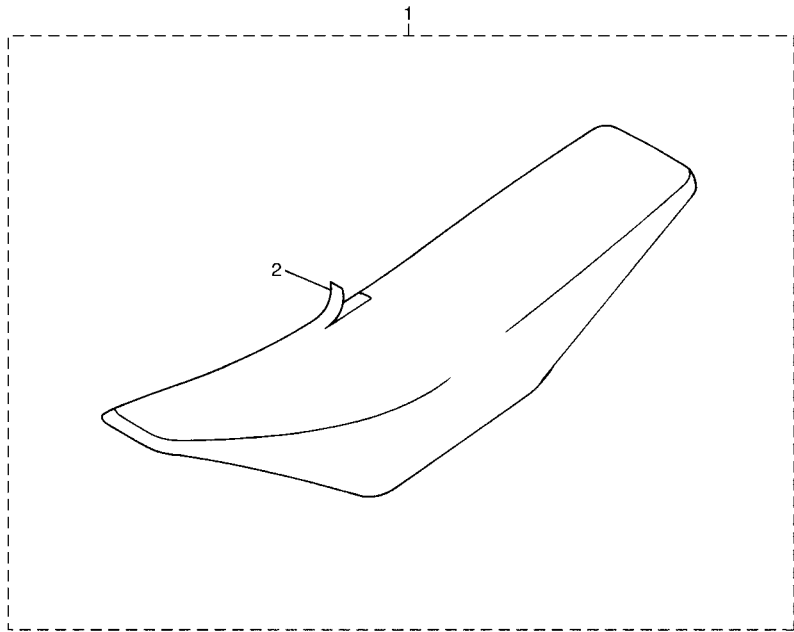

5TA1100-B270

FIG. 29 FRONT WHEEL

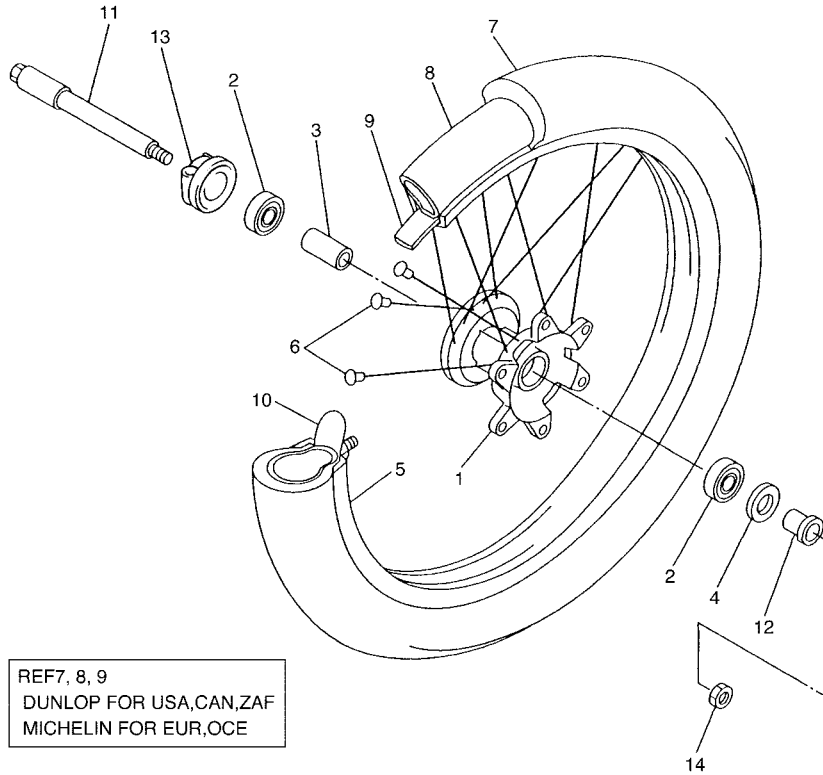

REF7, 8, 9
DUNLOP FOR USA,CAN,ZAF
MICHELIN FOR EUR,OCE

REF. NO.	PART NO.	DESCRIPTION	5TJ1	5TJ2	5TJ4	REMARKS
1	5NG-25111-50	HUB, FRONT	1	1	1	
2	93306-90403	BEARING	2	2	2	
3	5NY-25117-00	SPACER, BEARING	1	1	1	
4	93102-26468	OIL SEAL	1	1	1	
5	94416-21003	RIM (1.60-21)	1	1	1	
6	5NY-25104-00	SPOKE SET, FRONT	1	1	1	
7	94108-21008	TIRE (80/100-21 51M D739FA)	1	1		UR DUNLOP
	*	TIRE (90/90-21 M/C 54R ENDURO)		1	1	UR LM MICHELIN
8	94227-21101	TUBE (80/100-21 M/C TR4)	1	1		UR DUNLOP
	*	TUBE (90/90-21)		1	1	UR LM MICHELIN
9	94309-21161	BAND, RIM (1.60-21)	1	1		UR DUNLOP
	*	BAND, RIM (1.60-21)		1	1	UR LM MICHELIN
10	5SF-25394-00	SPACER, BEAD	1	1	1	
11	5BE-25181-00	AXLE, WHEEL	1	1	1	
12	5NY-25183-00	COLLAR, WHEEL	1	1	1	
13	5NG-25190-50	GEAR UNIT ASSY	1	1	1	
14	90179-16672	NUT	1	1	1	



5TJ1100-B290

FIG. 30 FRONT BRAKE CALIPER

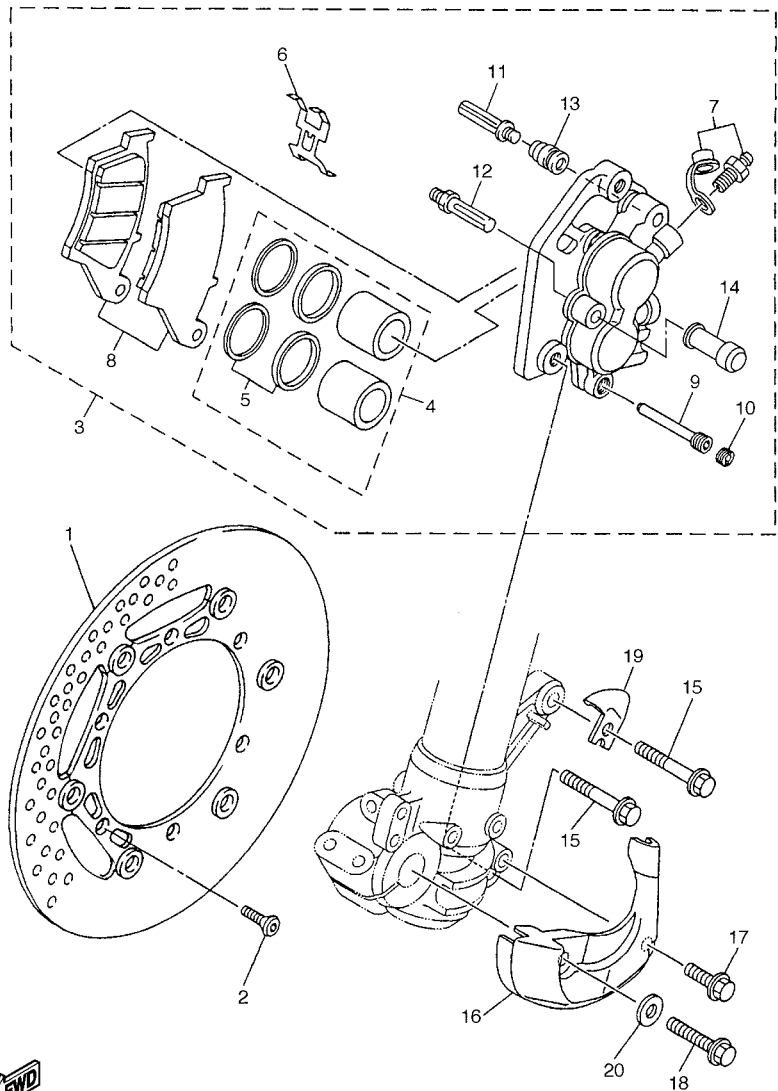

5TJ1100-B300

REF. NO.	PART NO.	DESCRIPTION	5TJ1	5TJ2	5TJ4	REMARKS
1	5MV-2581T-00	DISC BRAKE ASSY	1	1	1	
2	90149-06327	SCREW	6	6	6	
3	5UN-2580T-00	CALIPER ASSY (LEFT)	1	1	1	
4	5UN-W0057-00	.PISTON ASSY, CALIPER	1	1	1	
5	3JD-W0047-00	..CALIPER SEAL KIT	1	1	1	
6	5DH-25919-00	.SUPPORT, PAD	1	1	1	
7	1UY-W0048-50	.BLEED SCREW KIT	1	1	1	
8	5MV-W0045-01	.BRAKE PAD KIT	1	1	1	
9	5DH-25933-00	.WASHER, PAD PIN	1	1	1	
10	5DH-25916-00	.PLUG	1	1	1	
11	3SP-25926-51	.BOLT	1	1	1	
12	3SP-25914-51	.PIN, SLIDE	1	1	1	
13	3JD-25917-00	.BOOT, CALIPER	1	1	1	
14	1UY-25937-51	.BOOT 2	1	1	1	
15	90105-08659	BOLT, FLANGE	2	2	2	
16	5DH-2314E-00	COVER, HOSE	1	1	1	
17	95827-06012	BOLT, FLANGE	1	1	1	
18	95027-08020	BOLT, FLANGE	1	1	1	
19	5DH-25875-00	HOLDER, BRAKE HOSE 1	1	1	1	
20	92907-08200	WASHER	1	1	1	

FIG. 31 REAR WHEEL

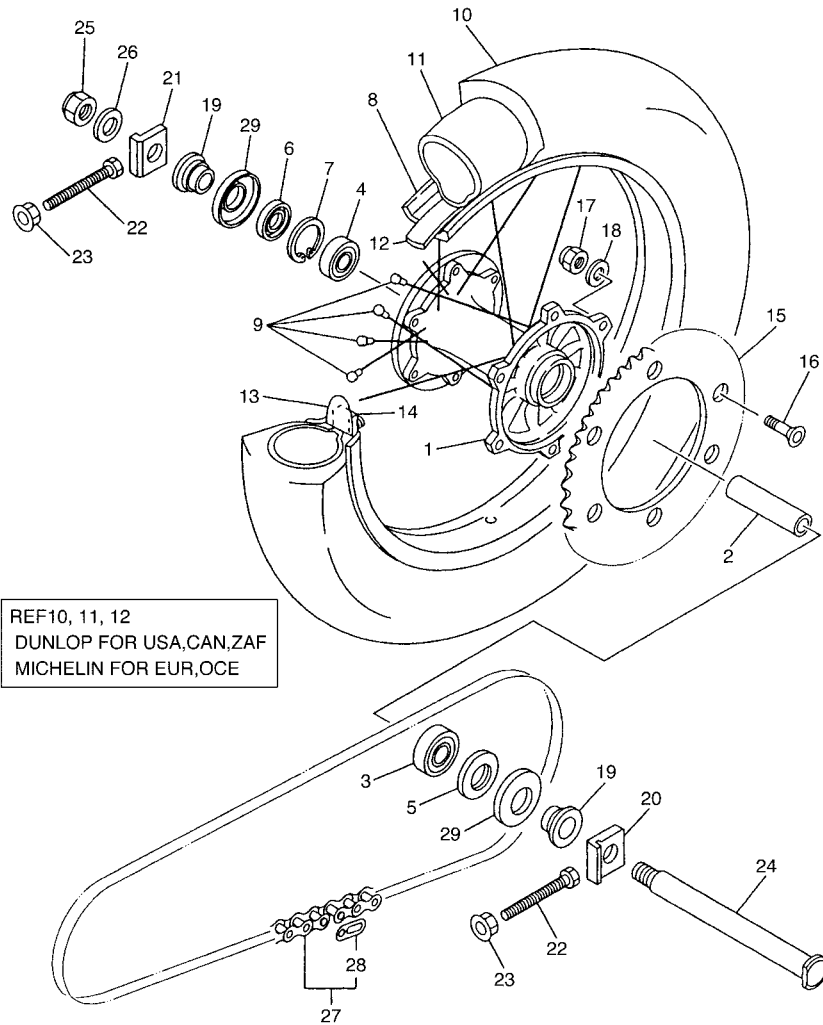

REF10, 11, 12
DUNLOP FOR USA,CAN,ZAF
MICHELIN FOR EUR,OCE



5TJ1100-B310

REF. NO.	PART NO.	DESCRIPTION	5TJ1	5TJ2	5TJ4	REMARKS
1	5ET-25311-00	HUB, REAR	1	1	1	
2	5ET-25317-00	SPACER, BEARING	1	1	1	
3	93306-27205	BEARING	1	1	1	
4	93306-07202	BEARING	1	1	1	
5	93106-30044	OIL SEAL	1	1	1	
6	93106-30045	OIL SEAL	1	1	1	
7	99009-45500	CIRCLIP	1	1	1	
8	94421-18610	RIM (2.15-18)	1	1	1	
9	5GS-25304-00	SPOKE SET, REAR	1	1	1	
10	94111-18008	TIRE (110/100-18 64M D739)	1	1		UR DUNLOP
*		TIRE(130/90-18 M/C 69R ENDURO)		1	1	UR LM MICHELIN
11	94212-18188	TUBE (110-140/80-100-18 M/C)	1	1		UR DUNLOP
*		TUBE TIRE (130/90-18M/C)		1	1	UR LM MICHELIN
12	94309-18146	BAND, RIM (2.15-18)	1	1		UR DUNLOP
*		BAND, RIM (2.15-18)		1	1	UR LM MICHELIN
13	3JE-25394-00	SPACER, BEAD	2	2	2	
14	4XM-25364-00	DAMPER	2	2	2	
15	5GS-25450-50	SPROCKET, DRIVEN (50T)	1	1	1	STD FOR CAN,ZAF
	5GS-25448-50	SPROCKET, DRIVEN (48T)	1	1	1	AP FOR CAN,ZAF
	5GS-25452-50	SPROCKET, DRIVEN (52T)	1	1	1	AP FOR CAN,ZAF
	5NY-25450-00	SPROCKET, DRIVEN (50T)			1	STD FOR OCE
	5NY-25448-00	SPROCKET, DRIVEN (48T)			1	AP FOR OCE
	5NY-25449-00	SPROCKET, DRIVEN (49T)			1	AP FOR OCE
	5NY-25451-00	SPROCKET, DRIVEN (51T)			1	AP FOR OCE
	5NY-25452-00	SPROCKET, DRIVEN (52T)			1	AP FOR OCE
16	90109-081G1	BOLT	6	6	6	
17	90185-08169	NUT, SELF-LOCKING	6	6	6	

FIG. 31 REAR WHEEL

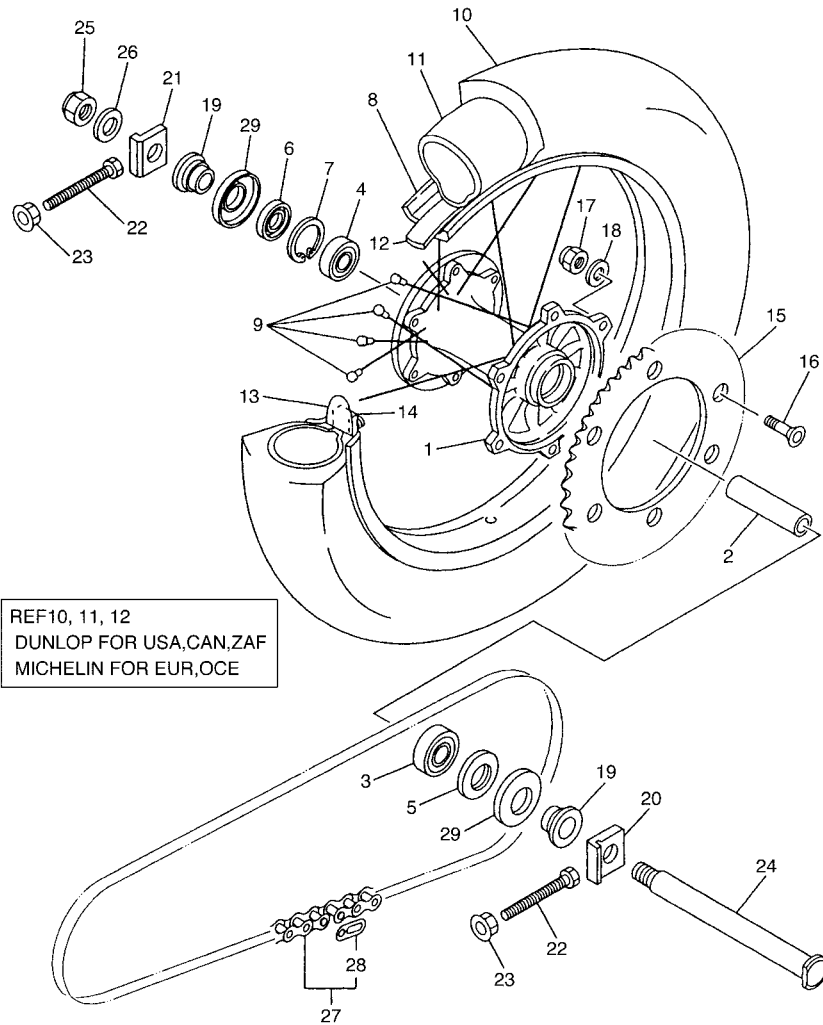

REF 10, 11, 12
DUNLOP FOR USA,CAN,ZAF
MICHELIN FOR EUR,OCE



5TJ1100-B310

REF. NO.	PART NO.	DESCRIPTION	5TJ1	5TJ2	5TJ4	REMARKS
18	90201-08326	WASHER, PLATE	6	6	6	
19	5UN-25383-00	COLLAR, WHEEL	2	2	2	
20	5NY-25388-00	PULLER, CHAIN 1	1	1	1	
21	5NY-25389-00	PULLER, CHAIN 2	1	1	1	
22	90101-08777	BOLT	2	2	2	
23	95707-08500	NUT, FLANGE	2	2	2	
24	5ET-25381-00	AXLE, WHEEL	1	1	1	
25	90185-20168	NUT, SELF-LOCKING	1	1	1	
26	90201-203U1	WASHER, PLATE	1	1	1	
27	9Y58A-76113	CHAIN (DID 520VM-114LL)	1	1	1	
28	94681-76021	JOINT, CHAIN	1	1	1	
29	5ET-25367-00	COVER, HUB DUST	2	2	2	

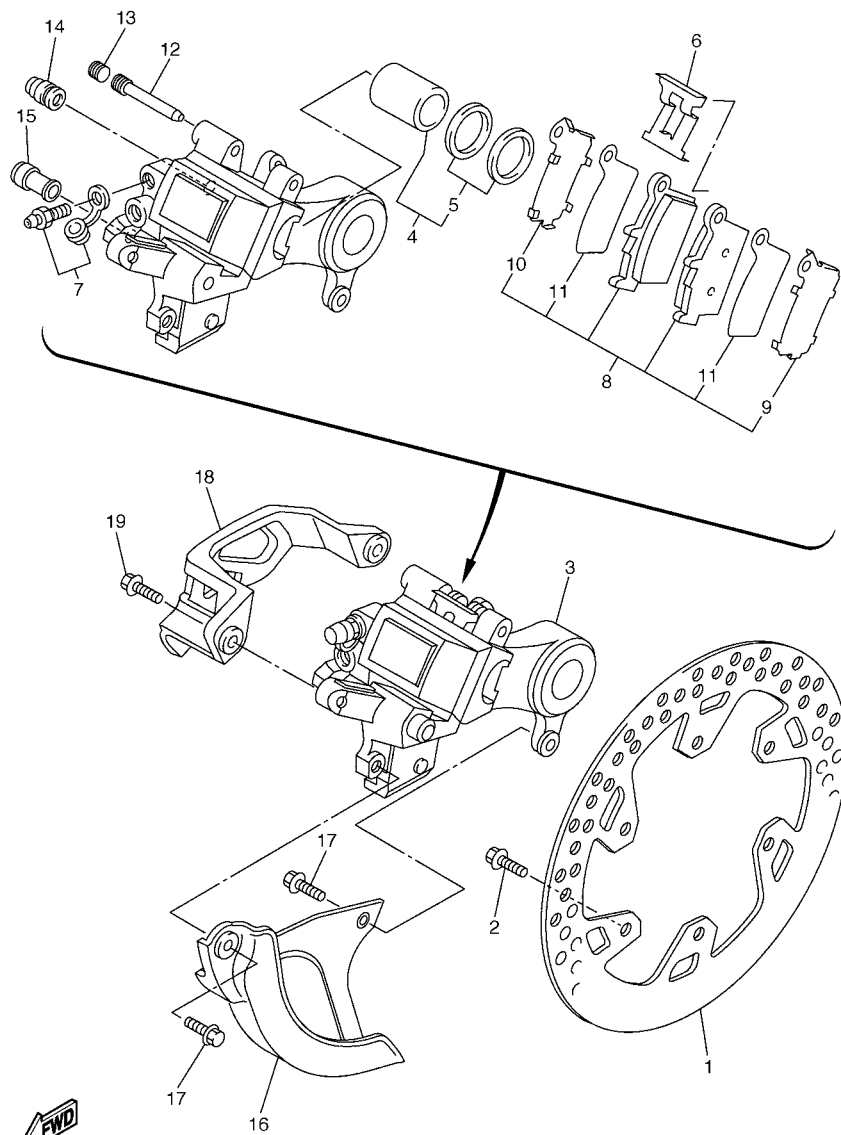
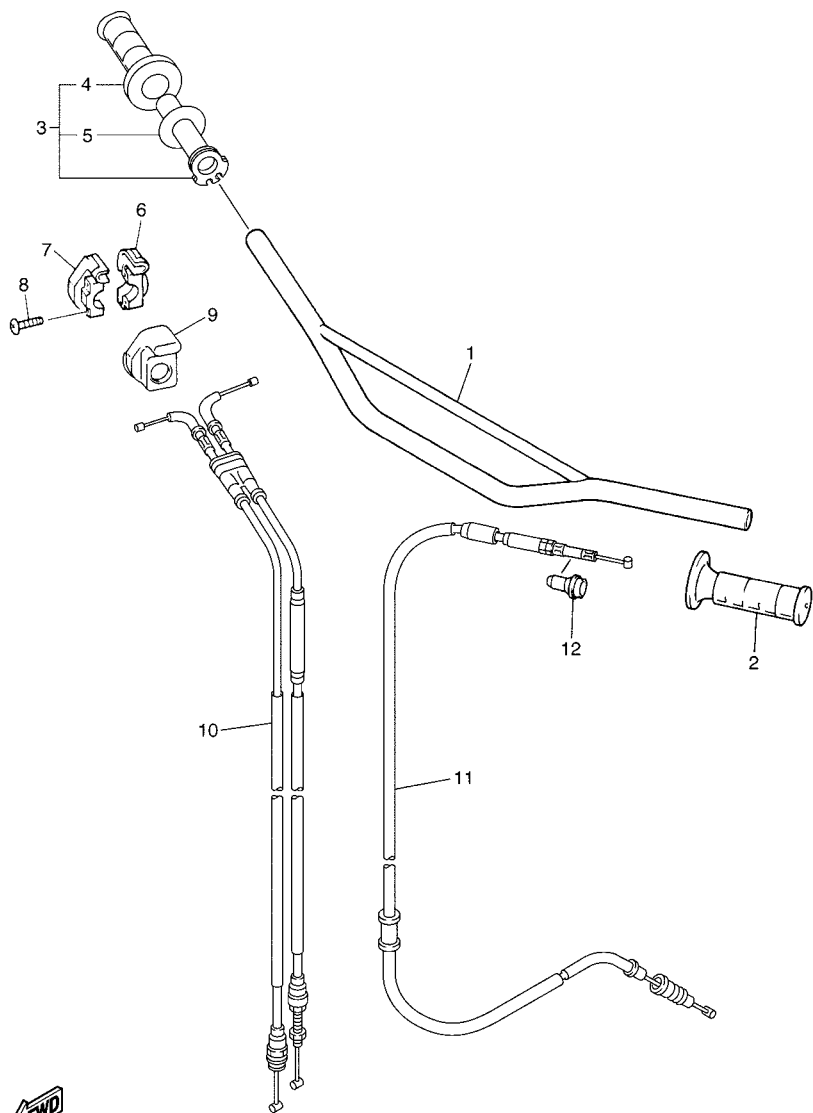

FIG. 32 REAR BRAKE CALIPER

REF. NO.	PART NO.	DESCRIPTION	5TJ1	5TJ2	5TJ4	REMARKS
1	5NY-2582W-00	DISC, REAR BRAKE 2	1	1	1	
2	90109-065G4	BOLT	6	6	6	
3	5UN-2580W-20	CALIPER ASSY, REAR 2	1	1	1	
4	5UN-W0057-50	.PISTON ASSY, CALIPER	1	1	1	
5	5UN-W0047-50	..CALIPER SEAL KIT	1	1	1	
6	5DH-25919-50	..SUPPORT, PAD	1	1	1	
7	1UY-W0048-50	.BLEED SCREW KIT	1	1	1	
8	5UN-W0046-60	.BRAKE PAD KIT 2	1	1	1	
9	5UN-25828-60	..SHIM, CALIPER	1	1	1	
10	5UN-25827-60	..SHIM, CALIPER	1	1	1	
11	5UN-22898-60	..INSULATOR, HEAT	2	2	2	
12	8CR-25924-00	.PIN, PAD	1	1	1	
13	5DH-25916-00	.PLUG	1	1	1	
14	3JD-25917-00	.BOOT, CALIPER	1	1	1	
15	1UY-25937-51	.BOOT 2	1	1	1	
16	5DH-25718-01	PROTECTOR, DISK BRAKE	1	1	1	
17	95027-06012	BOLT, FLANGE	2	2	2	
18	5TA-27491-00	PROTECTOR	1	1	1	
19	95027-06016	BOLT, FLANGE	2	2	2	

5TJ1100-B320

FIG. 33 STEERING HANDLE. CABLE



5TJ1100-B330

REF. NO.	PART NO.	DESCRIPTION	5TJ1	5TJ2	5TJ4	REMARKS
1	4XM-26111-00	HANDLEBAR	1	1	1	
2	4GY-26241-00	GRIP	1	1	1	
3	5BE-26240-00	GRIP ASSY	1	1	1	
4	4GY-26242-00	.GRIP (RIGHT)	1	1	1	
5	3Y1-26249-00	.RING, LEAF	1	1	1	
6	5BE-26281-00	CAP, GRIP UPPER	1	1	1	
7	5BE-26282-00	CAP, GRIP LOWER	1	1	1	
8	98507-05020	SCREW, PAN HEAD	2	2	2	
9	5SF-26287-00	COVER, CAP GRIP	1	1	1	
10	5TA-26302-01	THROTTLE CABLE ASSY	1	1	1	
11	5TJ-26335-00	CABLE, CLUTCH	1	1	1	
12	5HD-26342-00	BOOT, CABLE	1	1	1	

FIG. 34 FRONT MASTER CYLINDER

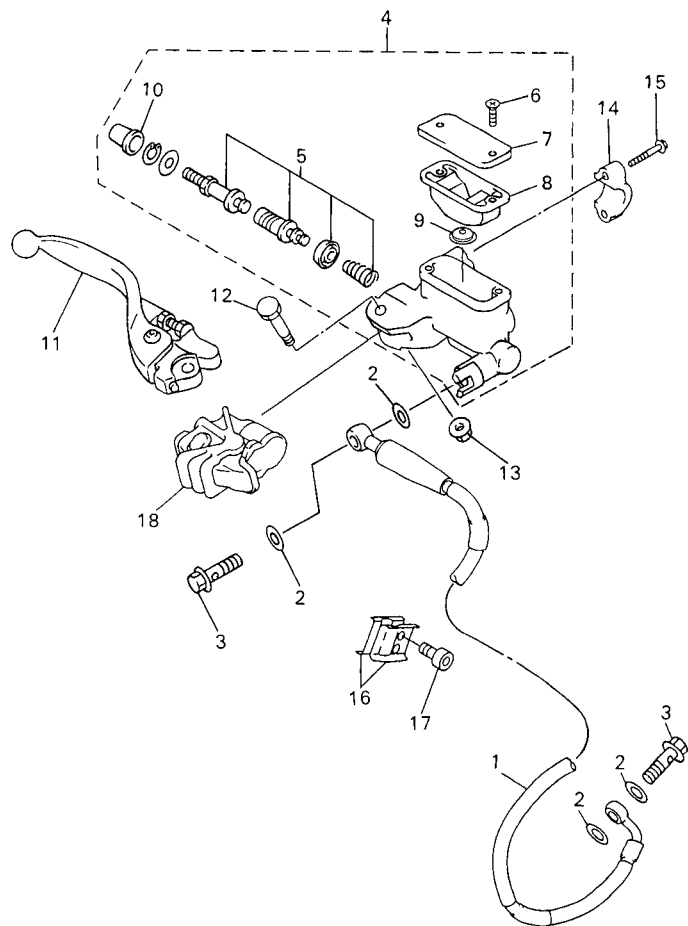

REF. NO.	PART NO.	DESCRIPTION	5TJ1	5TJ2	5TJ4	REMARKS
1	5TJ-25872-00	HOSE, BRAKE 1	1	1	1	
2	90201-10118	WASHER, PLATE	4	4	4	
3	90401-10172	BOLT, UNION	2	2	2	
4	5UN-W2587-00	MASTER CYLINDER SUB ASSY	1	1	1	
5	5NY-W0041-00	.CYLINDER KIT, MASTER	1	1	1	
6	98706-04012	.SCREW, FLAT HEAD	2	2	2	
7	5MV-25852-01	.CAP, RESERVOIR	1	1	1	
8	56A-25854-00	.DIAPHRAGM, RESERVOIR	1	1	1	
9	5CG-25715-00	.SEPARATOR ASSY	1	1	1	
10	5NY-25868-00	.BOOT, MASTER CYLINDER	1	1	1	
11	5MV-83922-00	LEVER 2	1	1	1	
12	5MV-2589F-00	BOLT, LEVER	1	1	1	
13	95701-06500	NUT, FLANGE	1	1	1	
14	5MV-25867-00	BRACKET, MASTER CYLINDER	1	1	1	
15	5MV-25833-00	BOLT, FITTING	2	2	2	
16	90465-16258	CLAMP	2	2	2	
17	91317-06014	BOLT	2	2	2	
18	5NY-26372-00	COVER, HANDLE LEVER 1	1	1	1	



5SF1100-2330

FIG. 35 STAND, FOOTREST

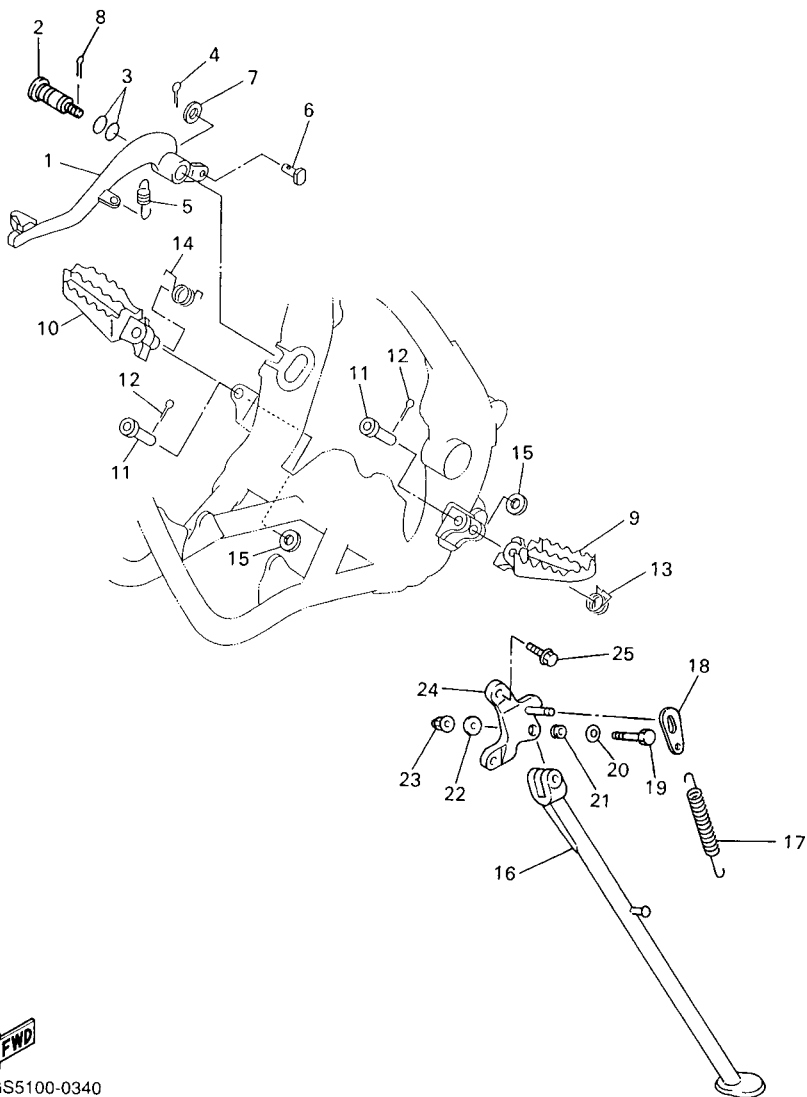

5GS5100-0340

REF. NO.	PART NO.	DESCRIPTION	5TJ1	5TJ2	5TJ4	REMARKS
1	5TA-27200-00	PEDAL, BRAKE	1	1	1	
2	5JG-27217-00	BOLT	1	1	1	
3	93210-11073	O-RING	2	2	2	
4	91401-20012	PIN, COTTER	1	1	1	
5	90506-16500	SPRING, TENSION	1	1	1	
6	90240-08120	PIN, CLEVIS	1	1	1	
7	90201-08089	WASHER, PLATE	1	1	1	
8	90468-16191	CLIP	1	1	1	
9	5ET-27411-00	FOOTREST 1	1	1	1	
10	5ET-27421-00	FOOTREST 2	1	1	1	
11	90240-10142	PIN, CLEVIS	2	2	2	
12	91401-25015	PIN, COTTER	2	2	2	
13	90508-282B8	SPRING, TORSION	1	1	1	
14	90508-282B9	SPRING, TORSION	1	1	1	
15	90201-10119	WASHER, PLATE	2	2	2	
16	5BF-27311-00	STAND, SIDE	1	1	1	
17	90506-35473	SPRING, TENSION	1	1	1	
18	5GS-27315-50	LINK, SIDE STAND	1	1	1	
19	90101-10738	BOLT	1	1	1	
20	90201-112U6	WASHER, PLATE	1	1	1	
21	90387-1003G	COLLAR	1	1	1	
22	92990-10200	WASHER, PLAIN	1	1	1	
23	95617-10100	NUT, U	1	1	1	
24	5GS-21458-50	BRACKET, SIDE STAND	1	1	1	
25	95027-10020	BOLT, FLANGE	2	2	2	

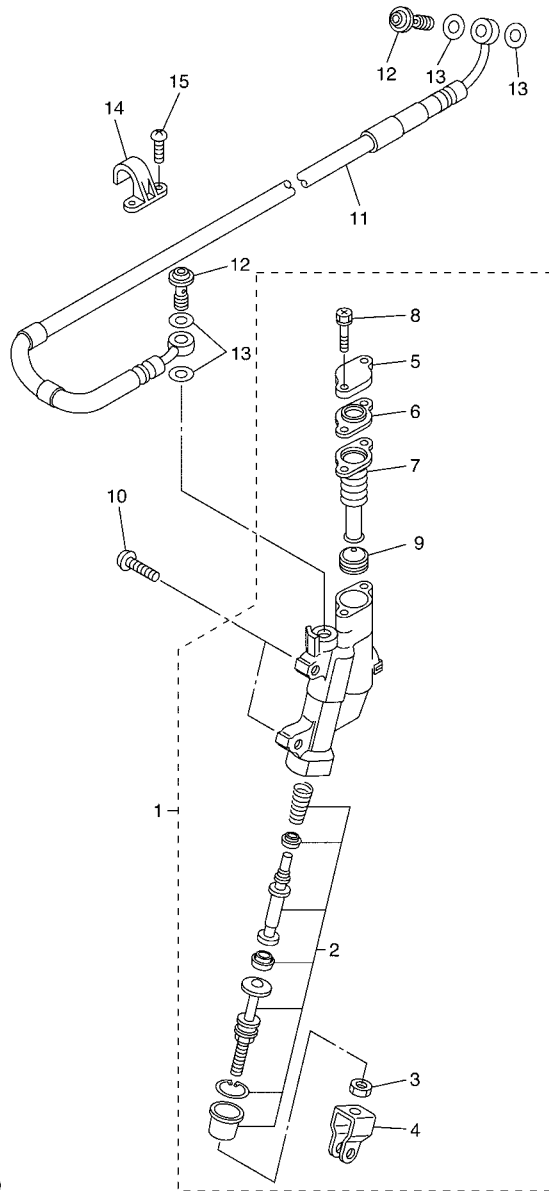

5TA1100-B350

FIG. 36 REAR MASTER CYLINDER

REF. NO.	PART NO.	DESCRIPTION	5TJ1	5TJ2	5TJ4	REMARKS
1	5UN-2583V-00	RR. MASTER CYLINDER ASSY.	1	1	1	
2	5UN-W0042-50	.CYLINDER KIT, MASTER	1	1	1	
3	5UN-27218-00	.NUT	1	1	1	
4	5UN-27222-00	.JOINT	1	1	1	
5	5UN-25852-50	.CAP, RESERVOIR	1	1	1	
6	5UN-2585B-00	.PLATE, DIAPHRAGM	1	1	1	
7	5UN-25854-00	.DIAPHRAGM, RESERVOIR	1	1	1	
8	5UN-27217-00	.BOLT	2	2	2	
9	5CG-25715-00	.SEPARATOR ASSY	2	2	2	
10	90111-06029	BOLT	2	2	2	
11	5UN-25873-00	HOSE, BRAKE 2	1	1	1	
12	90401-10172	BOLT, UNION	2	2	2	
13	90201-10118	WASHER, PLATE	4	4	4	
14	2VM-25876-00	HOLDER, BRAKE HOSE 2	2	2	2	
15	98507-05010	SCREW, PAN HEAD	4	4	4	

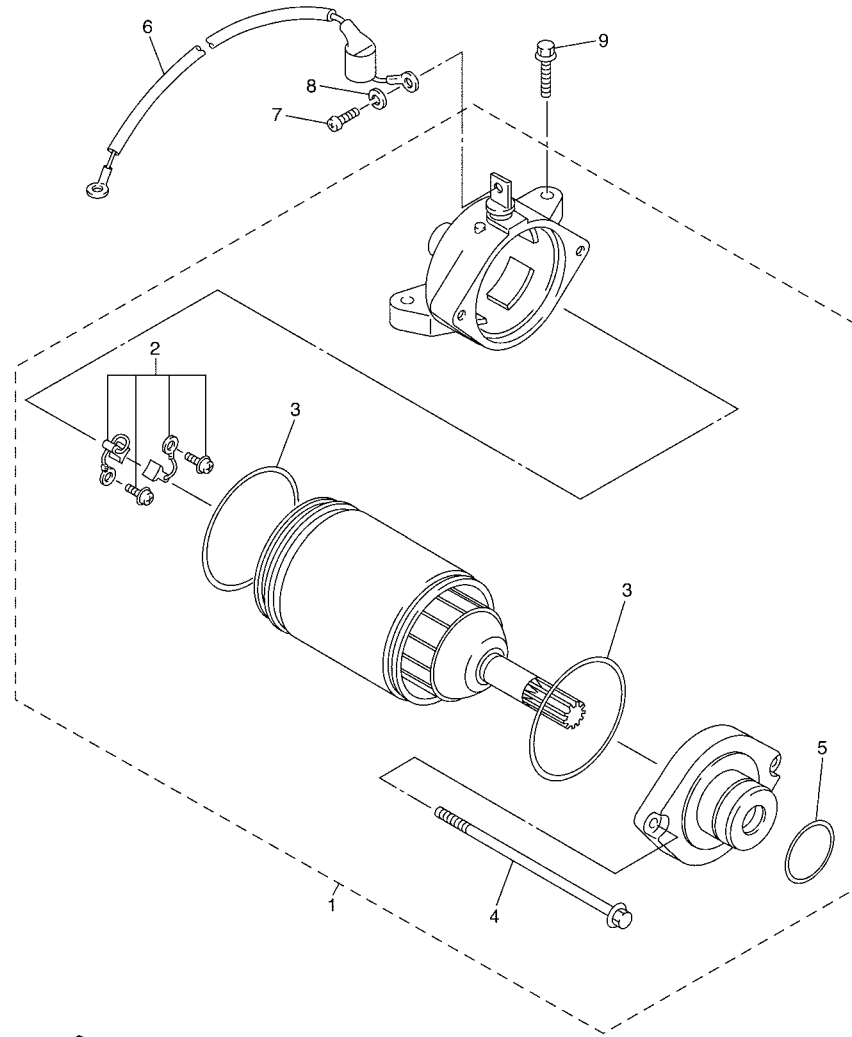
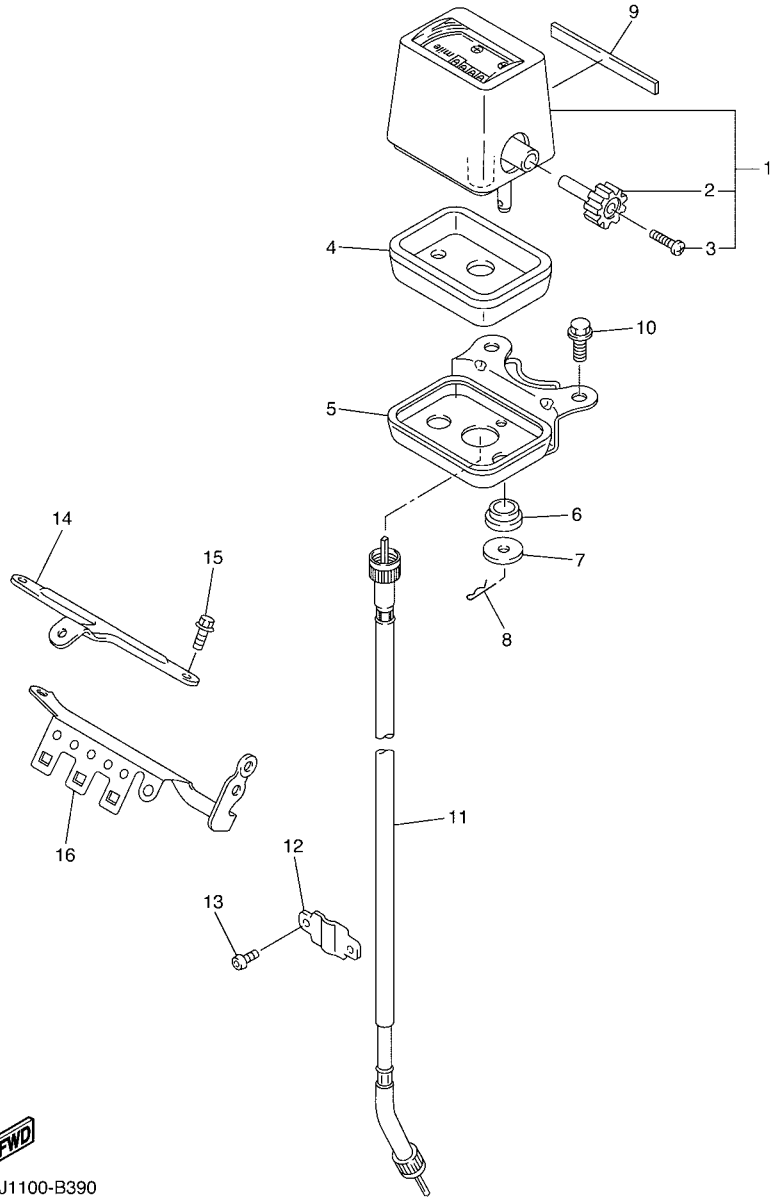

FIG. 38 STARTING MOTOR

REF. NO.	PART NO.	DESCRIPTION	5TJ1	5TJ2	5TJ4	REMARKS
1	5TJ-81890-00	MOTOR ASSY	1	1	1	
2	5TJ-81801-00	.BRUSH SET	1	1	1	
3	93210-44678	.O-RING	2	2	2	
4	50W-81846-M0	.SCREW	2	2	2	
5	93210-25711	.O-RING	1	1	1	
6	5TJ-8183G-00	CORD COMP.	1	1	1	
7	98507-05008	SCREW, PAN HEAD	1	1	1	
8	92907-05100	WASHER, SPRING	1	1	1	
9	95027-06025	BOLT, FLANGE	2	2	2	



5TJ1100-B380



FWD
5TJ1100-B390

FIG. 39 METER

REF. NO.	PART NO.	DESCRIPTION	5TJ1	5TJ2	5TJ4	REMARKS
1	5TJ-8355W-10	TRIP METER COMP. (MILE)	1	1		FOR GBR
	5TJ-8355W-00	TRIP METER COMP. (KM/H)		1	1	
2	1AE-83578-00	.KNOB, TRIP METER	1	1	1	
3	90157-02031	.SCREW, PAN HEAD	1	1	1	
4	4V5-83513-00	DAMPER	1	1	1	
5	5NG-83519-00	BRACKET, METER	1	1	1	
6	1M1-83526-00	DAMPER 2	2	2	2	
7	90201-05033	WASHER, PLATE	2	2	2	
8	437-83525-00	CLIP	2	2	2	
9	2HR-83592-00	DAMPER	1	1	1	
10	95027-06010	BOLT, FLANGE	2	2	2	
11	5BF-83550-00	SPEEDOMETER CABLE ASSY	1	1	1	
12	5BF-2317M-00	STAY 3	1	1	1	
13	92017-05008	BOLT, BUTTON HEAD	2	2	2	
14	5NG-84319-50	STAY, HEADLIGHT 2	1	1	1	
15	95027-08012	BOLT, FLANGE	2	2	2	
16	5TJ-8350E-00	BRACKET	1	1	1	

FIG. 40 HEADLIGHT

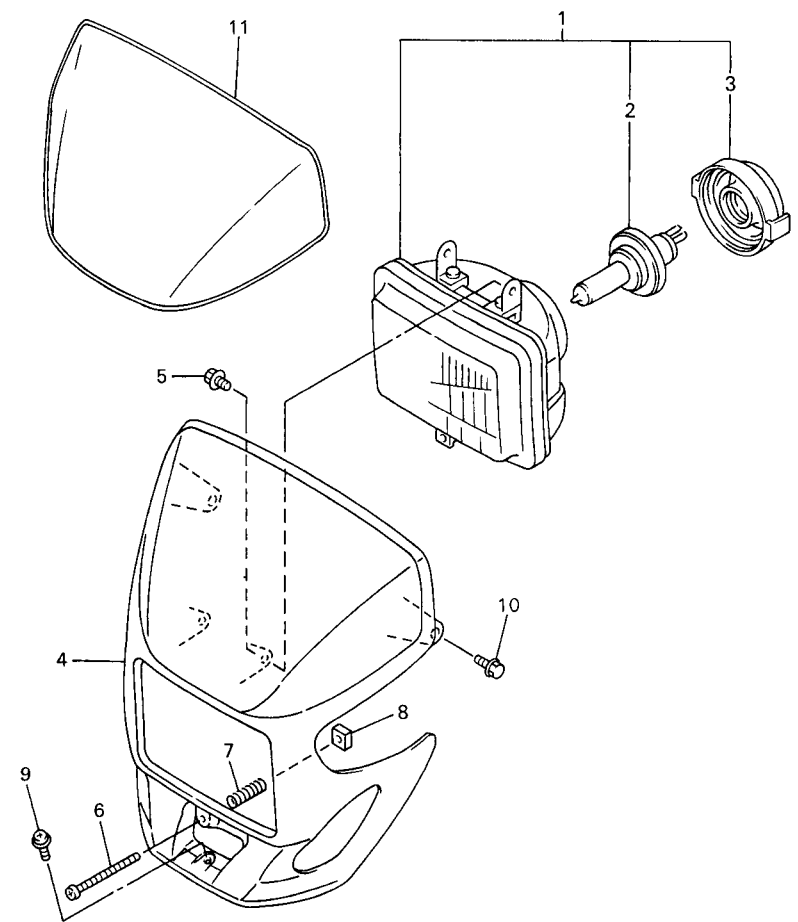

FWD
5NG1100-1380

REF. NO.	PART NO.	DESCRIPTION	5TJ1	5TJ2	5TJ4	REMARKS
1	5BF-84310-00	HEADLIGHT UNIT ASSY	1	1	1	
2	8G9-84314-00	.BULB (12V-60/55W)	1	1	1	(H4)HALOGEN
3	5BF-84397-00	.COVER, SOCKET	1	1	1	
4	5BF-84330-00	BODY ASSY	1	1	1	
5	55U-84337-00	BOLT, SPECIAL	2	2	2	
6	5BF-8433E-00	SCREW, ADJUSTING	1	1	1	
7	5BF-84335-00	SPRING	1	1	1	
8	5BF-84334-00	NUT, ADJUSTING	1	1	1	
9	90159-06189	SCREW, WITH WASHER	1	1	1	
10	95827-06010	BOLT, FLANGE	2	2	2	
11	5BF-2339E-00	GRAPHIC 1	1	1	1	

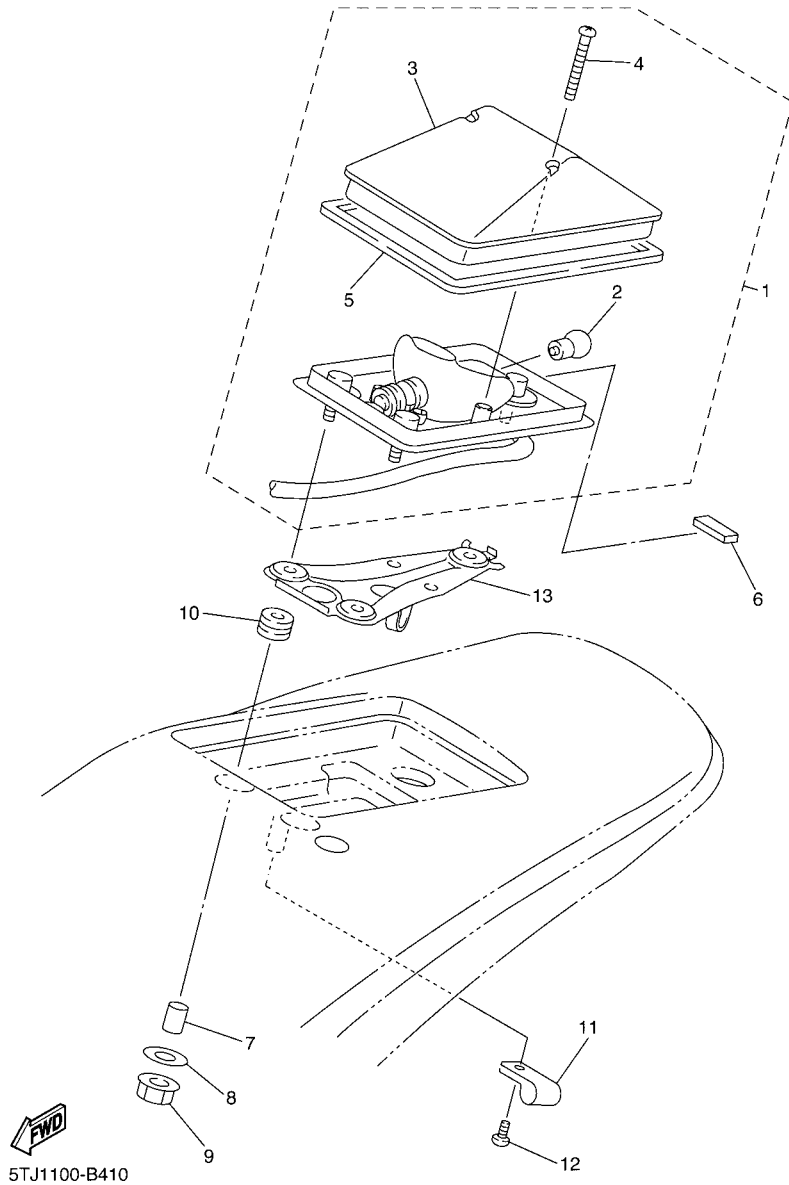

FIG. 41 TAILLIGHT

REF. NO.	PART NO.	DESCRIPTION	5TJ1	5TJ2	5TJ4	REMARKS
1	5TJ-84710-00	TAILLIGHT UNIT ASSY	1	1	1	
2	36Y-84714-40	.BULB, TAILLIGHT (12V-21/5W)	1	1	1	
3	4GY-84733-00	.LENS, TAILLIGHT	1	1	1	
4	97706-40530	.SCREW, TAPPING	2	2	2	
5	4GY-84723-00	.GASKET, TAIL LENS	1	1	1	
6	1HX-27415-00	PLATE, DAMPER	1	1	1	
7	90387-065L5	COLLAR	3	3	3	
8	90201-06057	WASHER, PLATE	3	3	3	
9	95707-06500	NUT, FLANGE	3	3	3	
10	90480-14102	GROMMET	3	3	3	
11	90461-11099	CLAMP	2	2	2	
12	97780-40010	SCREW, TAPPING	2	2	2	
13	5TJ-21677-00	PLATE, FITTING 3	1	1	1	

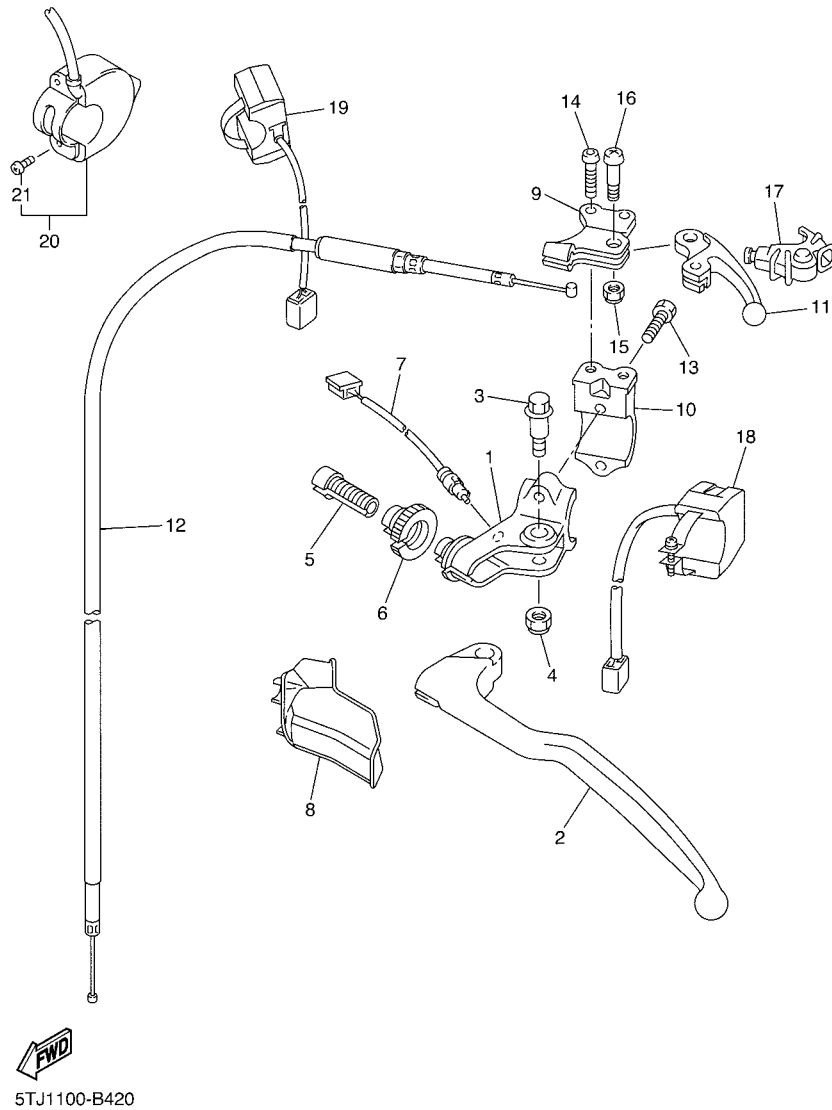
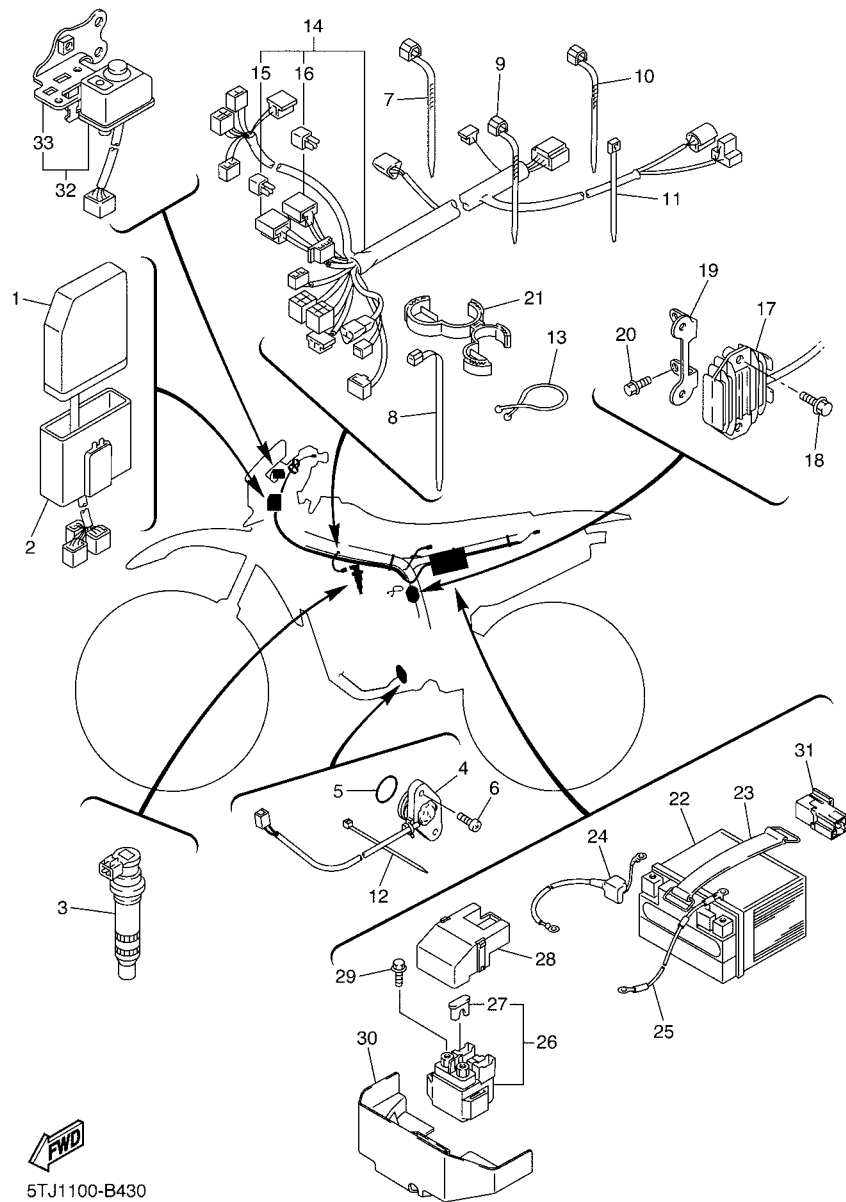

FIG. 42 HANDLE SWITCH. LEVER

REF. NO.	PART NO.	DESCRIPTION	5TJ1	5TJ2	5TJ4	REMARKS
1	5TJ-82911-00	HOLDER, LEVER 1	1	1	1	
2	5TJ-83912-00	LEVER 1	1	1	1	
3	90109-06027	BOLT	1	1	1	
4	95607-06100	NUT, U	1	1	1	
5	5TA-26337-00	BOLT, ADJUSTING	1	1	1	
6	5HD-83951-00	BOLT, CABLE ADJUSTING	1	1	1	
7	5TJ-82917-00	SWITCH	1	1	1	
8	5TJ-26372-00	COVER, HANDLE LEVER 1	1	1	1	
9	5TA-82946-00	HOLDER, STARTER LEVER	1	1	1	
10	5TA-82913-01	HOLDER, LEVER LOWER 1	1	1	1	
11	5TA-83941-00	LEVER, STARTER	1	1	1	
12	5TA-26334-00	CABLE, STARTER 2	1	1	1	
13	97007-05016	BOLT	2	2	2	
14	92017-05012	BOLT, BUTTON HEAD	2	2	2	
15	95607-05100	NUT, U	1	1	1	
16	90149-05163	SCREW	1	1	1	
17	5TA-26339-00	BOOT	1	1	1	
18	5TJ-83976-00	SWITCH, HANDLE 1	1	1	1	
19	5TJ-83976-10	SWITCH, HANDLE 1	1	1	1	
20	5NG-83976-50	SWITCH, HANDLE 1	1	1	1	
21	98507-04014	SCREW, PAN HEAD	2	2	2	



5TJ1100-B430

FIG. 43 ELECTRICAL 1

REF. NO.	PART NO.	DESCRIPTION	5TJ1	5TJ2	5TJ4	REMARKS
1	5TJ-85540-00	C.D.I. UNIT ASSY	1			
	5TJ-85540-10	C.D.I. UNIT ASSY		1	1	
2	5TJ-85546-00	BAND	1	1	1	
3	5TA-82310-00	IGNITION COIL ASSY	1	1	1	
4	5TJ-82540-00	NEUTRAL SWITCH ASSY	1	1	1	
5	93210-21276	O-RING	1	1	1	
6	90154-05026	SCREW, BINDING	2	2	2	
7	90464-13077	CLAMP	4	4	4	
8	90465-13275	CLAMP	5	5	5	
9	90464-13073	CLAMP	5	5	5	
10	90464-15195	CLAMP	1	1	1	
11	90465-13152	CLAMP	3	3	3	
12	5Y9-12491-00	CLAMP 1	5	5	5	
13	90464-23041	CLAMP	1	1	1	
14	5TJ-82590-00	WIRE HARNESS ASSY	1			
	5TJ-82590-10	WIRE HARNESS ASSY		1	1	
15	5TJ-81980-00	.DIODE ASSY	1	1	1	
16	4WA-81980-00	.DIODE ASSY	1	1	1	
17	5TJ-81960-00	RECTIFIER & REGULATOR ASSY	1	1	1	
18	95027-06020	BOLT, FLANGE	2	2	2	
19	5TJ-2128A-00	BRACKET, REGULATOR	1	1	1	
20	95027-06010	BOLT, FLANGE	2	2	2	
21	90464-29223	CLAMP	1	1	1	
22	5TJ-82100-00	BATTERY ASSY (YTZ7S)	1	1	1	
23	8CY-82131-00	BAND, BATTERY	1	1	1	
24	5TJ-82115-00	WIRE, PLUS LEAD	1	1	1	
25	5TJ-82116-00	WIRE, MINUS LEAD	1	1	1	

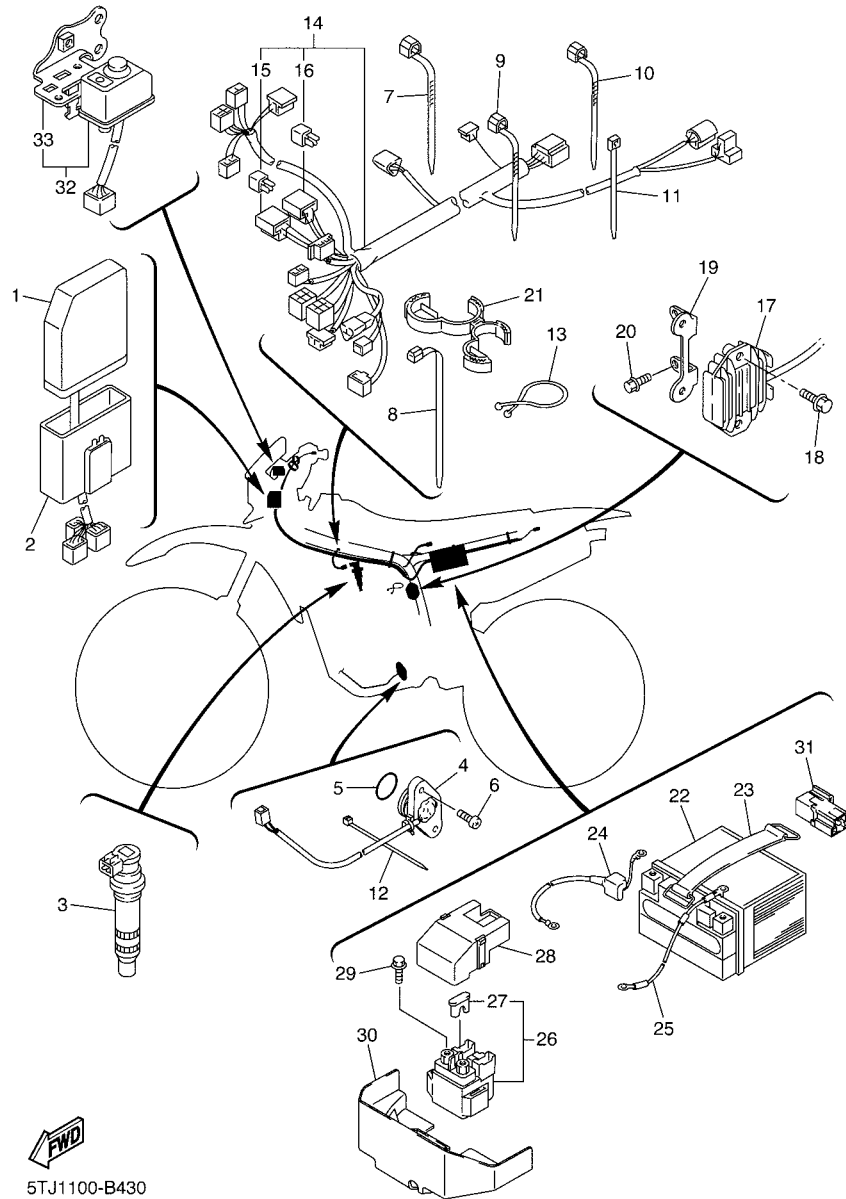
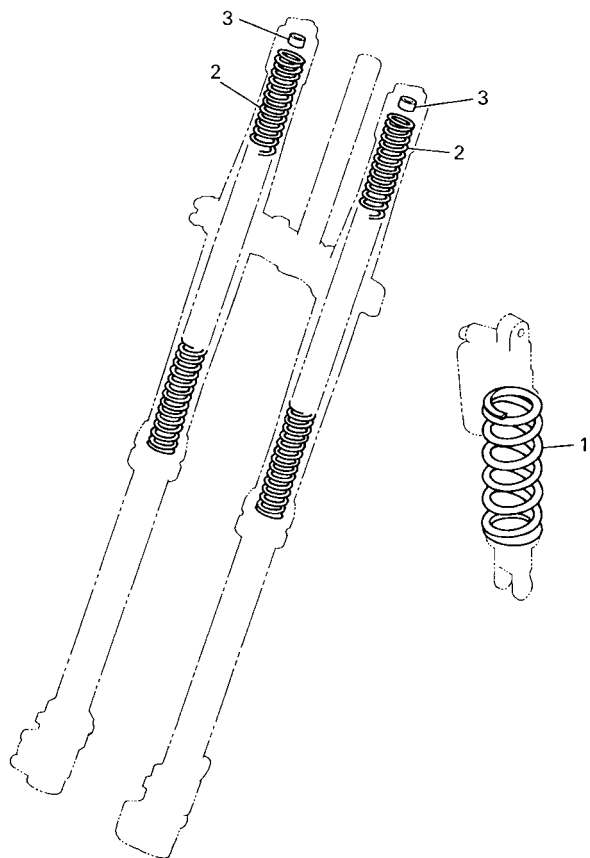

FIG. 43 ELECTRICAL 1

REF. NO.	PART NO.	DESCRIPTION	5TJ1	5TJ2	5TJ4	REMARKS
26	5TJ-81940-10	STARTER RELAY ASSY	1	1	1	
27	42X-82151-00	.FUSE (10A-BL)	2	2	2	
28	5SL-82119-10	COVER, LEAD WIRE	1	1	1	
29	95027-06008	BOLT, FLANGE	2	2	2	
30	5TJ-81952-00	HOLDER, RELAY	1	1	1	
31	8DM-81950-00	RELAY ASSY	1	1	1	
32	5TJ-82510-00	MAIN SWITCH ASSY	1	1	1	
33	5TJ-82514-00	.STAY, MAIN SWITCH	1	1	1	

FIG. 44 ALTERNATE (CHASSIS)



REF. NO.	PART NO.	DESCRIPTION	5TJ1	5TJ2	5TJ4	REMARKS
1	5UN-22212-00	SPRING (K=4.3)	1	1	1	AP
	5UN-22212-10	SPRING (K=4.5)	1	1	1	AP
	5UN-22212-20	SPRING (K=4.7)	1	1	1	AP
	5UN-22212-30	SPRING (K=4.9)	1	1	1	AP
	5UN-22212-40	SPRING (K=5.1)	1	1	1	AP
	5UN-22212-50	SPRING (K=5.3)	1	1	1	AP
	5UN-22212-60	SPRING (K=5.5)	1	1	1	AP
	5UN-22212-70	SPRING (K=5.7)	1	1	1	AP
	5UN-22212-A0	SPRING (K=APPROX.4.5)	1	1	1	AP
	5UN-22212-B0	SPRING (K=APPROX.4.7)	1	1	1	AP
	5UN-22212-C0	SPRING (K=APPROX.4.9)	1	1	1	AP
	5UN-22212-D0	SPRING (K=APPROX.5.1)	1	1	1	AP
	5UN-22212-E0	SPRING (K=APPROX.5.3)	1	1	1	AP
	5UN-22212-F0	SPRING (K=APPROX.5.5)	1	1	1	AP
	5UN-22212-G0	SPRING (K=APPROX.5.7)	1	1	1	AP
2	4SS-23141-10	SPRING, FRONT FORK (K=0.38)	2	2	2	AP
	4SS-23141-20	SPRING, FRONT FORK (K=0.39)	2	2	2	AP
	4SS-23141-30	SPRING, FRONT FORK (K=0.40)	2	2	2	AP
	4SS-23141-40	SPRING, FRONT FORK (K=0.41)	2	2	2	AP
	4SS-23141-50	SPRING, FRONT FORK (K=0.42)	2	2	2	AP
	4SS-23141-60	SPRING, FRONT FORK (K=0.43)	2	2	2	AP
	4SS-23141-70	SPRING, FRONT FORK (K=0.44)	2	2	2	AP
	5BE-23141-L0	SPRING, FRONT FORK (K=0.45)	2	2	2	AP
	5BE-23141-00	SPRING, FRONT FORK (K=0.46)	2	2	2	AP
	5GR-23141-00	SPRING, FRONT FORK (K=0.47)	2	2	2	AP
	5ET-23141-20	SPRING (K=APPROX.0.40)	2	2	2	AP
	5ET-23141-00	SPRING (K=APPROX.0.41)	2	2	2	AP



5BE100-8390

F6

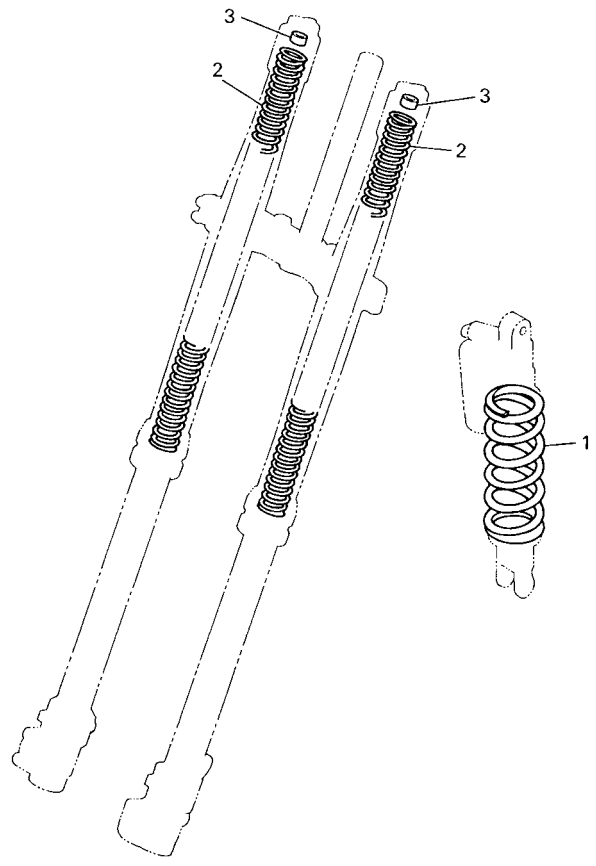
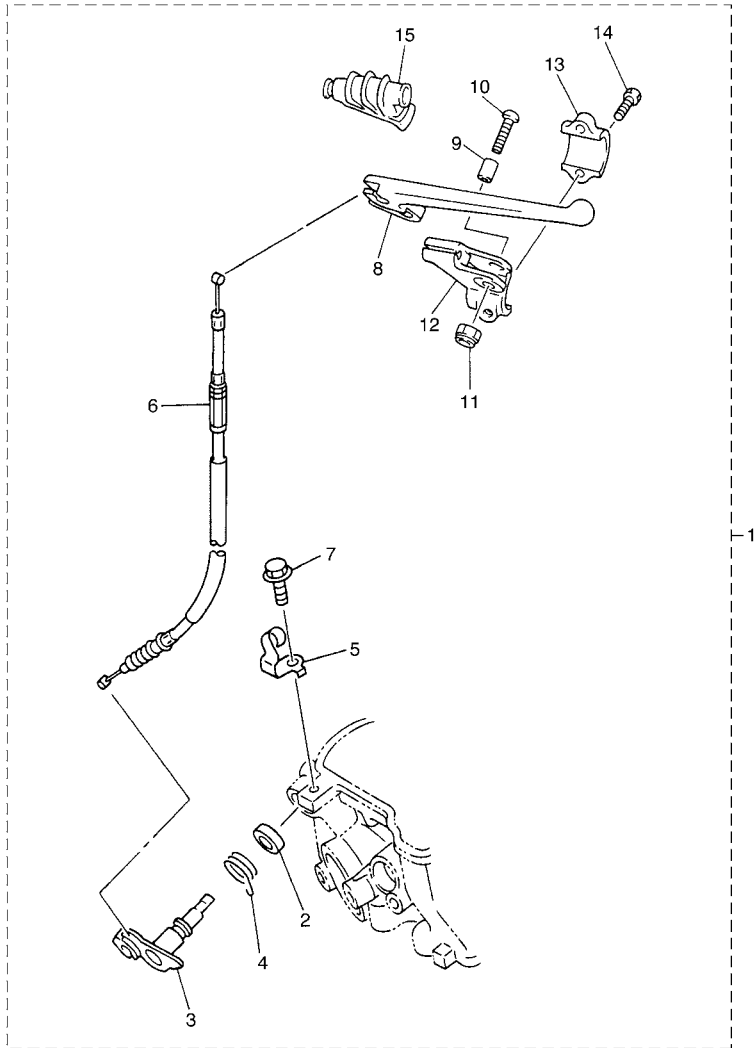

FIG. 44 ALTERNATE (CHASSIS)

REF. NO.	PART NO.	DESCRIPTION	5TJ1	5TJ2	5TJ4	REMARKS
2	5ET-23141-30	SPRING (K=APPROX.0.42)	2	2	2	AP
	5ET-23141-10	SPRING (K=APPROX.0.43)	2	2	2	AP
	5ET-23141-40	SPRING (K=APPROX.0.44)	2	2	2	AP
3	4SS-23364-L0	COLLAR 2	2	2	2	UN
<hr style="border-top: 1px dashed black;"/>						
<hr style="border-top: 1px dashed black;"/>						
<hr style="border-top: 1px dashed black;"/>						
<hr style="border-top: 1px dashed black;"/>						
<hr style="border-top: 1px dashed black;"/>						
<hr style="border-top: 1px dashed black;"/>						
<hr style="border-top: 1px dashed black;"/>						
<hr style="border-top: 1px dashed black;"/>						



5BE100-8390



5TA1100-B400

FIG. 45 ALTERNATE

REF. NO.	PART NO.	DESCRIPTION	5TJ1	5TJ2	5TJ4	REMARKS
1	5TA-W1228-00	DECOMPRESSION KIT	1			AP
2	93102-12224	.OIL SEAL	1			
3	5BE-12280-10	.DECOMPRESSION ASSY	1			
4	90508-162B2	.SPRING, TORSION	1			
5	5NL-12283-00	.BRACKET, DECOMPRESSION	1			
6	5BE-12292-10	.CABLE, DECOMPRESSION	1			
7	95827-06014	.BOLT, FLANGE	1			
8	583-83981-00	.LEVER, DECOMPRESSION	1			
9	5BE-83913-00	.COLLAR, LEVER 1	1			
10	98507-05020	.SCREW, PAN HEAD	1			
11	95607-05100	.NUT, U	1			
12	5BE-82912-00	.HOLDER, LEVER UPPER 1	1			
13	38V-82913-00	.HOLDER, LEVER LOWER 1	1			
14	97007-05016	.BOLT	2			
15	583-26352-00	.COVER, DECOMPRESSION CABLE	1			

NUMERICAL INDEX

PART NO.	GRID NO.	PART NO.	GRID NO.	PART NO.	GRID NO.	PART NO.	GRID NO.	PART NO.	GRID NO.	PART NO.	GRID NO.
5TA-11102-00	B - 2	3LD-12168-M1	B - 5	5BE-13411-00	B - 10	5TJ-1443A-00	B - 13	5JG-14940-18	C - 2	5TA-15415-00	C - 6
4KG-1111G-00	B - 2	3LD-12168-R1	B - 5	5TA-13412-00	B - 10	5BF-1443E-00	B - 13	5JG-14940-19	C - 2	5TA-15421-00	C - 5
5TA-11133-10	B - 2	3LD-12168-U1	B - 5	5TA-13440-00	B - 11	5NY-14442-00	B - 12	5TA-14943-19	C - 2	5TJ-15423-00	C - 6
5TA-11134-10	B - 2	3LD-12168-W1	B - 5	5BE-13447-10	B - 11	5TJ-14451-00	B - 12	5TA-14943-21	C - 2	5TA-15431-00	C - 6
5TA-11166-00	B - 2	3LD-12168-Y1	B - 5	5TA-13464-00	B - 10	5TA-14453-00	B - 12	4MX-14943-35	B - 15	5TA-15441-00	C - 5
5BE-11167-00	B - 2	3LD-12169-11	B - 5	5TA-13465-00	B - 10	5NY-14455-10	B - 12	4MX-14943-36	B - 15	5TJ-15451-00	C - 6
371-11167-01	B - 2	3LD-12169-31	B - 6	5TA-13597-00	B - 12	5TJ-14457-00	B - 13	4MX-14943-37	B - 15	5TA-15453-00	C - 7
5TA-11181-00	B - 2	3LD-12169-50	B - 6	5TJ-14101-00	B - 14	5TJ-14458-00	B - 12	4MX-14943-38	B - 15	5TA-15462-00	C - 6
5TA-11191-00	B - 2	3LD-12169-70	B - 6	5TJ-14101-10	B - 14	5TJ-14459-00	B - 12	4MX-14943-39	B - 15	5TJ-15512-00	C - 9
5TA-11193-00	B - 2	3LD-12169-90	B - 6	5NL-14105-00	C - 2	5TJ-14462-00	B - 13	4MX-14943-40	B - 15	5TJ-15515-00	C - 9
5TA-11311-01	B - 3	3LD-12169-E0	B - 6	4MX-14115-00	C - 3	5TJ-14475-00	B - 12	4MX-14943-41	B - 15	5TJ-15517-00	C - 9
5TA-11351-00	B - 3	3LD-12169-G0	B - 6	3TJ-14137-40	B - 12	5JG-14521-00	B - 14	4MX-14943-86	B - 15	4GY-15521-00	C - 9
5TJ-11400-00	B - 4	3LD-12169-J0	B - 6		C - 3	5JG-14522-00	B - 14	4MX-14943-87	B - 15	5TJ-15590-00	C - 9
5TJ-11412-00	B - 4	3LD-12169-L0	B - 6	5BE-14146-00	C - 3	5JG-14531-00	C - 3	4MX-14943-88	B - 15	5TA-15601-00	C - 8
5TA-11422-00	B - 4	3LD-12169-N0	B - 6	5PA-14146-00	C - 3	3TJ-14536-40	C - 2	4MX-14943-89	B - 15	5TA-15620-01	C - 8
5BE-11454-00	B - 4	3LD-12169-T0	B - 6	5TA-14155-00	C - 3	5JG-14546-01	B - 14	4MX-14943-90	B - 15	5TA-15621-01	C - 8
5TA-11455-00	B - 4	5TA-12170-00	B - 7	633-14159-00	C - 2	676-14548-00	C - 2	4MX-14943-91	B - 15	5TA-15651-00	C - 8
5TA-11531-01	B - 4	5TJ-12180-10	B - 7	3TJ-14159-40	B - 14	4MX-14561-00	C - 3	5JG-14947-00	B - 15	5NL-15664-00	C - 8
5TA-11536-00	B - 4	5TA-12210-00	B - 7	5TA-14171-00	C - 2	6H4-14561-00	C - 2	4MX-14948-03	B - 15	5SG-15668-00	C - 8
5JG-11603-00	B - 4	4FM-12213-00	B - 7	3TJ-14191-40	C - 2	5NX-14562-00	C - 3	4MX-14948-04	B - 15	4GY-15671-00	C - 8
5TA-11631-00	B - 4	5BE-12241-00	B - 7	5TA-14196-00	C - 3	5JG-14565-00	C - 3	4MX-14948-05	B - 15	214-15686-00	C - 8
5TA-11633-00	B - 4	5TA-12251-01	B - 7	5TA-14197-00	C - 3	5JG-14591-00	C - 3	4MX-14948-06	B - 15	5TA-16111-00	C - 10
5TA-11651-00	B - 4	5TA-12252-00	B - 7	5NX-14216-00	C - 3	5TJ-14591-00	C - 3	4MX-14948-07	B - 15	5TA-16150-11	C - 10
5TA-11681-00	B - 4	5BE-12280-10	F - 8	5TA-14227-00	B - 12	688-14592-00	B - 14	4MX-14948-08	B - 15	5TA-16154-00	C - 10
5TA-12111-00	B - 5	5NL-12283-00	F - 8	5TA-14239-00	B - 12	5TA-14611-00	C - 4	4JT-1494F-07	C - 2	5JG-16321-00	C - 10
5TA-12112-00	B - 5	5BE-12292-10	F - 8	5TA-14261-00	C - 3	3VD-14613-01	C - 4	3TJ-1494F-10	C - 2	5TA-16321-00	C - 10
5TA-12113-00	B - 5	5TJ-1240A-00	B - 9	5JG-14264-00	B - 15	5TA-14628-00	C - 4	3TJ-1494F-11	C - 2	5JG-16325-00	C - 10
5TA-12114-00	B - 5	5BE-12422-20	B - 8	3TJ-14267-40	B - 14	5TJ-14710-00	C - 4	3TJ-1494F-12	C - 2	5TJ-16325-00	C - 10
4GY-12117-00	B - 5	5BE-12439-00	B - 8	5JG-14275-00	B - 15	5TJ-14710-10	C - 4	3TJ-1494F-13	B - 15	5JG-16351-00	C - 10
5BE-12117-00	B - 5	5DJ-12451-00	B - 8	5TA-14293-00	B - 12	3GW-14714-00	C - 4	3TJ-1494F-14	C - 2	5JG-16356-00	C - 10
1AA-12118-00	B - 5	5GR-12458-00	B - 8	3TJ-14293-40	C - 2	4BD-14766-00	C - 4	3TJ-1494F-15	C - 2	5TA-16357-00	C - 10
1WG-12118-00	B - 5	5TJ-12461-00	B - 9	5TA-14335-00	C - 2	5BE-14788-00	C - 4	4JT-1494F-15	C - 2	5TA-16371-00	C - 10
33M-12119-00	B - 5	5HD-12462-00	B - 9	5JG-14346-00	C - 3	5TJ-14916-D1	B - 14	5JG-14951-00	B - 14	5TJ-16381-00	C - 10
4SV-12119-00	B - 5	5TA-12481-00	B - 9	5TA-14371-00	C - 2	5TJ-14916-DM	B - 14	5GS-14958-00	C - 3	5JG-16383-00	C - 10
5TA-12121-00	B - 5	5TA-12482-00	B - 9	5TA-14374-00	C - 3	5TJ-14916-DN	B - 14	5JG-14959-00	B - 14	5JG-16384-00	C - 10
3GM-12126-00	B - 5	5Y9-12491-00	F - 4	5JG-14379-00	C - 3	5TJ-14916-DP	B - 14	5JG-14984-00	C - 2	5TA-16384-00	C - 10
3FV-12153-00	B - 6	5BE-12564-00	B - 8	5JG-14388-00	B - 14	5TJ-14916-DR	B - 14	4SR-14985-00	C - 2	5BF-17121-00	C - 12
3FV-12153-10	B - 6	5TA-12576-00	B - 9	4MX-14392-00	C - 2	5TJ-14916-DS	B - 14	5TA-14987-00	B - 12	5TJ-17131-00	C - 12
3FV-12153-20	B - 6	5TA-12578-00	B - 9	5TJ-14401-00	B - 12	5TJ-14916-DT	B - 14	5TJ-14987-00	C - 3	5TJ-17141-00	C - 12
3LD-12168-00	B - 5	5SG-12579-00	B - 9	5TJ-1441A-00	B - 13	5TJ-14916-DU	B - 14	5TA-14991-00	C - 2	5TJ-17151-00	C - 12
3LD-12168-20	B - 5	5TA-12579-00	B - 9	5TJ-1441E-00	B - 12	5TJ-14916-DV	B - 14	4FN-14997-00	B - 14	5BF-17211-00	C - 12
3LD-12168-40	B - 5	583-13113-00	C - 7	5TJ-1441G-00	B - 12	5TA-14916-DW	B - 14	5TA-14997-00	C - 3	5TJ-17221-00	C - 12
3LD-12168-60	B - 5	5TA-13161-00	B - 11	5TJ-14425-00	B - 12	5JG-14922-00	C - 3	5TJ-15150-00	C - 5	5TJ-17231-00	C - 12
3LD-12168-80	B - 5	5TA-13171-00	B - 11	5TJ-14426-00	B - 12	5GS-14933-00	C - 3	5TA-15362-01	D - 3	5TJ-17241-00	C - 12
3LD-12168-A0	B - 5	5TA-13300-00	B - 10	5TA-14428-00	B - 12	5GS-14933-40	C - 2	3Y1-15363-00	C - 6	5BF-17251-00	C - 12
3LD-12168-F0	B - 5	5TA-13320-00	B - 10	5TJ-1442A-00	B - 13	5TA-14934-00	C - 3	4JT-15381-01	C - 5	5BE-17402-00	C - 12
3LD-12168-H1	B - 5	5TA-13341-00	B - 10	5TJ-14436-00	B - 12	5GS-14940-00	C - 3	5BE-15383-01	C - 5	5TJ-17411-00	C - 12
3LD-12168-K1	B - 5	5BE-13342-00	B - 10	5TJ-14437-00	B - 12	5JG-14940-17	C - 2	5TJ-15411-00	C - 6	5NG-17460-00	C - 13

NUMERICAL INDEX

PART NO.	GRID NO.	PART NO.	GRID NO.	PART NO.	GRID NO.	PART NO.	GRID NO.	PART NO.	GRID NO.	PART NO.	GRID NO.
5TA-17466-00	C - 5	5TJ-21730-00	D - 5	5UN-22212-A0	F - 6	4SR-23141-L0	D - 11	2GU-24500-01	D - 14	5MV-25867-00	E - 9
4L0-17471-00	C - 5	5TJ-2173E-00	D - 5	5UN-22212-B0	F - 6	5BE-23141-L0	F - 6	4X8-24512-00	D - 14	5NY-25868-00	E - 9
5GR-17471-00	C - 13	5TJ-2173F-00	D - 5	5UN-22212-C0	F - 6	5GR-23141-L0	D - 11	3AJ-24523-00	D - 14	5TJ-25872-00	E - 9
5TA-18101-00	C - 15	5TJ-21740-00	D - 5	5UN-22212-D0	F - 6	5DH-23142-L0	D - 11	3AJ-24534-00	D - 14	5UN-25873-00	E - 11
5UL-18110-00	C - 15	3JD-21748-00	D - 4	5UN-22212-E0	F - 6	5HD-23144-L0	D - 11	5NY-24610-00	D - 14	5DH-25875-00	E - 4
5LP-18122-00	C - 15	5TJ-2174A-00	D - 5	5UN-22212-F0	F - 6	5UN-23145-L0	D - 11	5TJ-2470F-00	E - 2	2VM-25876-00	E - 11
3XK-18140-00	C - 14	5TJ-2174T-00	D - 4	5UN-22212-G0	F - 6	5UN-23146-L0	D - 11	5TJ-24710-00	E - 2	5MV-2589F-00	E - 9
5BE-18172-00	C - 15	5TA-21756-00	D - 2	3SP-22213-00	D - 8	5DH-23149-L0	D - 11	5NY-25104-00	E - 3	3SP-25914-51	E - 4
3XJ-18173-00	C - 15	2TK-21757-00	B - 13	5DH-22214-00	D - 8	5DH-2314E-00	E - 4	5NG-25111-50	E - 3	5DH-25916-00	E - 4
3XJ-18178-00	C - 15	5TJ-21757-00	B - 13	5MV-22224-00	D - 8	5DH-2314F-L0	D - 12	5NY-25117-00	E - 3		E - 7
3XJ-18182-00	C - 15	4XV-2177L-00	B - 12	4JX-22226-00	D - 8	4SS-2314G-L0	D - 12	5BE-25181-00	E - 3	3JD-25917-00	E - 4
3XJ-18184-00	C - 15	5JG-21781-50	D - 5	3SP-22234-00	D - 8	5TA-2314H-00	D - 13	5NY-25183-00	E - 3		E - 7
4EW-18185-00	C - 15	5GS-21871-00	D - 5	5NY-22241-00	D - 9	5TJ-2314J-00	D - 13	5NG-25190-50	E - 3	5DH-25919-00	E - 4
5BE-18501-00	C - 14	26H-21874-00	D - 5	5DH-22253-00	D - 8	4SS-23153-L0	D - 11	5GS-25304-00	E - 5	5DH-25919-50	E - 7
5BE-18502-10	C - 14	26H-21875-00	D - 5	5MV-22253-00	D - 8	4SS-23158-L0	D - 11	5ET-25311-00	E - 5	8CR-25924-00	E - 7
5BE-18503-00	C - 14	5UN-22110-00	D - 6	5UN-22355-00	D - 6	5TJ-2316A-L0	D - 11	5ET-25317-00	E - 5	3SP-25926-51	E - 4
5NL-18541-00	C - 14	5NY-22121-00	D - 6	4EW-22474-00	D - 8	5TJ-2316A-M0	D - 11	4XM-25364-00	E - 5	5DH-25933-00	E - 4
278-18542-00	C - 14	5NY-22122-00	D - 7	3JE-22475-00	D - 8	5TJ-23170-L0	D - 11	5ET-25367-00	E - 6	1UY-25937-51	E - 4
5DH-18562-00	C - 5	5UN-22128-00	D - 6	5NY-22475-00	D - 8	5ET-23171-L0	D - 11	5ET-25381-00	E - 6		E - 7
5TJ-21101-00	D - 2	5NY-22141-01	D - 6	5UN-22898-60	E - 7	5BF-2317M-00	E - 14	5UN-25383-00	E - 6	4XM-26111-00	E - 8
5TA-21161-00	D - 2	5UN-22151-00	D - 6	5TJ-23102-00	D - 11	5DH-23183-00	D - 8	5NY-25388-00	E - 6	5BE-26240-00	E - 8
5TJ-21190-00	D - 2	5JG-22156-00	D - 6	5TJ-23102-10	D - 11	509-23184-L0	D - 8	5NY-25389-00	E - 6	4GY-26241-00	E - 8
5TJ-2128A-00	F - 4	5MV-22176-00	D - 8	5TJ-23102-40	D - 11	5MV-23195-L0	D - 11	3JE-25394-00	E - 5	4GY-26242-00	E - 8
5TJ-21335-00	D - 2	4EW-22178-00	D - 2	5TJ-23103-00	D - 11	5TJ-2319U-00	D - 10	5SF-25394-00	E - 3	3Y1-26249-00	E - 8
5NG-21338-00	D - 3	3JD-22178-10	D - 2	5TJ-23103-10	D - 11	5HC-2331E-00	D - 13	5NY-25448-00	E - 5	5BE-26281-00	E - 8
5TJ-21338-00	D - 3	5NY-2217A-00	D - 6	5TJ-23103-40	D - 12	5UP-23340-L0	D - 12	5GS-25448-50	E - 5	5BE-26282-00	E - 8
5HD-2135F-00	D - 7	5NY-2217F-00	D - 7	5BF-23110-L0	D - 12	4SS-23346-L0	D - 13	5NY-25449-00	E - 5	5SF-26287-00	E - 8
5NY-2135F-00	D - 7	5MV-22184-00	D - 8	5UN-23111-L0	D - 11	5NY-23346-L0	D - 12	5NY-25450-00	E - 5	5TA-26302-01	E - 8
5TA-21417-00	D - 3	5UN-22199-00	D - 6	5DH-23118-L0	D - 11	3SP-23356-L0	D - 13	5GS-25450-50	E - 5	5TA-26334-00	F - 3
5TA-21425-00	D - 2	5TJ-22201-00	D - 8	5DH-23120-L0	D - 11	4SS-23364-L0	F - 7	5NY-25451-00	E - 5	5TJ-26335-00	E - 8
5TA-21425-10	D - 2	5TJ-22201-10	D - 8	5ET-23125-L0	D - 11	4DA-23389-00	D - 10	5NY-25452-00	E - 5	5TA-26337-00	F - 3
5GS-21458-50	E - 10	5TJ-22201-30	D - 8	3JD-2312G-L0	D - 11	4GY-23389-00	D - 10	5GS-25452-50	E - 5	5TA-26339-00	F - 3
5TA-21471-00	D - 3	5TJ-22201-40	D - 8	5TA-23136-L0	D - 11	5HD-23393-L0	D - 11	5CG-25715-00	E - 9	5HD-26342-00	E - 8
5TA-2147A-00	D - 3	5TJ-22210-00	D - 8	5BE-23141-00	F - 6	5BF-2339E-00	E - 15		E - 11	583-26352-00	F - 8
5TA-2147E-00	D - 3	5TJ-22210-10	D - 8	5ET-23141-00	F - 6	4EW-23416-00	D - 10	5DH-25718-01	E - 7	5NY-26372-00	E - 9
5TJ-2147F-00	D - 3	5TJ-22210-30	D - 8	5GR-23141-00	F - 6	5PH-23435-00	D - 10	5UN-2580T-00	E - 4	5TJ-26372-00	F - 3
5HD-21511-00	D - 4	5TJ-22210-40	D - 8	5NL-23141-00	D - 11	3SP-23441-00	D - 10	5UN-2580W-20	E - 7	5TA-27200-00	E - 10
5UN-2153A-00	D - 7	5UN-22212-00	F - 6	4SS-23141-10	F - 6	5TJ-24110-00	D - 14	5MV-2581T-00	E - 4	5JG-27217-00	E - 10
4XL-2153A-10	D - 13	5UN-22212-10	F - 6	5ET-23141-10	F - 7	4EW-2412F-00	D - 14	5UN-25827-60	E - 7	5UN-27217-00	E - 11
4ES-2153E-01	D - 4	5UN-22212-20	F - 6	4SS-23141-20	F - 6	24X-24144-00	D - 14	5UN-25828-60	E - 7	5UN-27218-00	E - 11
5TJ-21610-00	D - 4	5UN-22212-30	D - 8	5ET-23141-20	F - 6	5SF-24173-00	D - 14	5NY-2582W-00	E - 7	5UN-27222-00	E - 11
5TA-21635-00	D - 4		F - 6	4SS-23141-30	F - 6	4FU-24181-00	C - 4	5MV-25833-00	E - 9	5BF-27311-00	E - 10
5TJ-2163G-00	D - 4	5UN-22212-40	F - 6	5ET-23141-30	F - 7	5TJ-24181-00	D - 14	5UN-2583V-00	E - 11	5GS-27315-50	E - 10
5TA-21642-00	D - 4	5UN-22212-50	D - 8	4SS-23141-40	F - 6	5BE-24182-00	D - 14	5MV-25852-01	E - 9	5ET-27411-00	E - 10
5TJ-21677-00	F - 2		F - 6	5ET-23141-40	F - 7	5NY-24183-00	D - 14	5UN-25852-50	E - 11	1HX-27415-00	F - 2
5TJ-21711-00	D - 5	5UN-22212-60	F - 6	4SS-23141-50	F - 6	5NY-24186-00	D - 14	56A-25854-00	E - 9	5ET-27421-00	E - 10
5TJ-21721-00	D - 5	5UN-22212-70	F - 6	4SS-23141-60	F - 6	5TJ-24240-01	D - 15	5UN-25854-00	E - 11	5TA-27491-00	E - 7
5TJ-2172A-00	D - 5	5UN-22212-90	D - 8	4SS-23141-70	F - 6	3XJ-24380-00	D - 14	5UN-2585B-00	E - 11	5TA-2814F-00	D - 3

NUMERICAL INDEX

PART NO.	GRID NO.	PART NO.	GRID NO.	PART NO.	GRID NO.	PART NO.	GRID NO.	PART NO.	GRID NO.	PART NO.	GRID NO.
5ET-28166-00	D - 3	5HD-83951-00	F - 3	90105-10733	D - 2	90185-10060	D - 9	90240-10142	E - 10	90464-13077	F - 4
5TJ-2831V-00	D - 10	5TJ-83976-00	F - 3	90109-06027	F - 3	90185-14007	D - 7	90267-32146	B - 12	90464-15195	F - 4
3FV-28386-00	B - 13	5TJ-83976-10	F - 3	90109-063F8	C - 14	90185-16127	D - 6	90280-03001	B - 4	90464-23041	F - 4
5TJ-81410-00	E - 12	5NG-83976-50	F - 3	90109-06418	B - 7	90185-20168	E - 6	90338-18064	B - 7	90464-29223	F - 4
5TJ-81450-00	E - 12	583-83981-00	F - 8	90109-065G2	B - 11	90201-03313	B - 12	90338-18176	D - 3	90465-10017	C - 6
5TJ-81801-00	E - 13	5BF-84310-00	E - 15	90109-065G4	E - 7	90201-05033	E - 14	90340-12112	B - 2	90465-13152	D - 14
5TJ-8183G-00	E - 13	8G9-84314-00	E - 15	90109-066F0	B - 2	90201-06057	F - 2	90340-14128	C - 6		F - 4
50W-81846-M0	E - 13	5NG-84319-50	E - 14	90109-081G1	E - 5	90201-06557	D - 4	90340-27002	C - 6	90465-13275	F - 4
5TJ-81890-00	E - 13	5BF-84330-00	E - 15	90109-082G0	C - 8	90201-06571	B - 9	90387-06009	D - 4	90465-16258	E - 9
5TJ-81940-10	F - 5	5BF-84334-00	E - 15	90110-06004	C - 9	90201-08089	E - 10	90387-06065	B - 9	90467-09006	D - 5
8DM-81950-00	F - 5	5BF-84335-00	E - 15	90110-06058	B - 10	90201-08326	C - 8	90387-065L5	F - 2	90467-10008	D - 14
5TJ-81952-00	F - 5	55U-84337-00	E - 15	90110-08096	D - 2		E - 6	90387-086N4	D - 2	90467-11106	B - 2
5TJ-81953-00	B - 13	5BF-8433E-00	E - 15	90111-06029	E - 11	90201-08410	C - 3	90387-1003G	E - 10	90467-14015	B - 2
5TJ-81960-00	F - 4	5BF-84397-00	E - 15	90119-05071	D - 10	90201-08512	B - 8	90387-124F4	C - 15	90467-17089	B - 13
4WA-81980-00	F - 4	5TJ-84710-00	F - 2	90119-06001	D - 3	90201-086P8	C - 4	90387-16005	D - 6	90468-16191	E - 10
5TJ-81980-00	F - 4	36Y-84714-40	F - 2	90119-06051	D - 5		D - 3	90387-16007	D - 6	90480-01512	D - 4
5TJ-82100-00	F - 4	4GY-84723-00	F - 2	90119-06096	D - 4	90201-10025	B - 2	90387-167Y9	D - 6	90480-14102	F - 2
5TJ-82115-00	F - 4	4GY-84733-00	F - 2	90119-06214	D - 14	90201-10118	E - 9	90387-18004	D - 6	90480-14532	D - 4
5TJ-82116-00	F - 4	5TJ-85540-00	F - 4	90119-06225	D - 4		E - 11	90387-18005	D - 6	90480-15528	B - 9
5SL-82119-10	F - 5	5TJ-85540-10	F - 4	90119-08238	D - 5	90201-10119	E - 10	90387-18007	C - 5	90480-18549	D - 14
8CY-82131-00	F - 4	5TJ-85546-00	F - 4	90149-05163	F - 3	90201-104R2	D - 2	90387-2113G	C - 12	90501-043E0	C - 7
42X-82151-00	F - 5	5TA-85885-00	C - 3	90149-06011	D - 14	90201-112U6	E - 10	90387-2513F	C - 12	90501-052G5	C - 15
5TA-82310-00	F - 4	5NY-W0041-00	E - 9	90149-06126	C - 5	90201-12020	E - 12	90401-08038	B - 11	90501-06022	C - 14
5TJ-82510-00	F - 5	5UN-W0042-50	E - 11	90149-06250	B - 4	90201-12166	B - 10	90401-10159	B - 11	90501-147A5	C - 8
5TJ-82514-00	F - 5	5MV-W0045-01	E - 4	90149-06326	C - 5	90201-125L6	C - 10	90401-10172	E - 9	90501-16016	C - 8
5TJ-82540-00	F - 4	5UN-W0046-60	E - 7	90149-06327	E - 4	90201-145M4	D - 2		E - 11	90501-22003	C - 10
5TJ-82590-00	F - 4	3JD-W0047-00	E - 4	90151-04048	D - 6	90201-14740	D - 7	90430-06014	B - 2	90506-16500	E - 10
5TJ-82590-10	F - 4	5UN-W0047-50	E - 7	90152-06010	C - 8	90201-15701	C - 6		B - 7	90506-35473	E - 10
5TJ-82911-00	F - 3	1UY-W0048-50	E - 4	90154-05026	F - 4	90201-160F6	D - 6		B - 8	90508-14020	C - 11
5BE-82912-00	F - 8		E - 7	90157-02031	E - 14	90201-162H4	C - 8		C - 5	90508-162B2	F - 8
38V-82913-00	F - 8	5UN-W0057-00	E - 4	90159-06078	D - 5	90201-167P7	C - 8	90430-08119	B - 11	90508-26561	C - 14
5TA-82913-01	F - 3	5UN-W0057-50	E - 7	90159-06092	C - 10	90201-20272	C - 9		D - 2	90508-282B8	E - 10
5TJ-82917-00	F - 3	5TA-W1228-00	F - 8	90159-06182	D - 5	90201-20276	C - 8	90430-10188	B - 11	90508-282B9	E - 10
5TA-82946-00	F - 3	5UN-W2587-00	E - 9	90159-06189	E - 15	90201-203U1	E - 6		C - 5	90508-291A8	C - 15
5TJ-8350E-00	E - 14	90101-06001	C - 8	90170-14171	B - 4	90201-20685	C - 8	90445-09100	D - 14	90508-30743	C - 8
4V5-83513-00	E - 14	90101-06664	C - 15	90170-20327	C - 10	90201-247L2	D - 10	90445-09220	D - 14	91314-06030	B - 10
5NG-83519-00	E - 14	90101-08777	E - 6	90170-24373	D - 10	90201-253K0	C - 12	90445-11185	D - 14	91316-04012	B - 14
437-83525-00	E - 14	90101-10738	E - 10	90179-06500	B - 3	90201-286K9	D - 10	90445-112K0	B - 2	91317-05008	D - 6
1M1-83526-00	E - 14	90105-05361	D - 10	90179-06568	D - 6	90202-05193	D - 14	90450-22017	B - 9	91317-05012	C - 6
5BF-83550-00	E - 14	90105-06027	B - 2	90179-10658	D - 2	90202-08045	B - 14		B - 10	91317-05020	E - 12
5TJ-8355W-00	E - 14	90105-06154	D - 4	90179-12657	E - 12	90206-06090	C - 4	90450-25037	B - 9	91317-06014	E - 9
5TJ-8355W-10	E - 14	90105-06553	C - 5	90179-16672	E - 3	90209-21332	C - 12	90450-28014	B - 9		E - 12
1AE-83578-00	E - 14		C - 13	90179-20001	C - 10	90209-26348	C - 12	90450-57004	B - 12	91317-06050	C - 5
2HR-83592-00	E - 14	90105-08120	D - 2		C - 13	90215-14287	B - 4	90450-59002	B - 12	91317-06060	C - 5
5TJ-83912-00	F - 3	90105-08659	E - 4	90179-28650	D - 10	90215-20231	C - 10	90450-61001	B - 12	91317-06075	C - 5
5BE-83913-00	F - 8	90105-10323	D - 8	90183-06023	B - 13	90215-21001	C - 10	90461-10136	C - 5	91317-08020	C - 4
5MV-83922-00	E - 9	90105-104A7	B - 2	90185-08169	E - 5		C - 13	90461-11099	F - 2	91401-20012	E - 10
5TA-83941-00	F - 3	90105-106A3	B - 2	90185-10002	D - 2	90240-08120	E - 10	90464-13073	F - 4	91401-25015	E - 10

NUMERICAL INDEX

PART NO.	GRID NO.	PART NO.	GRID NO.	PART NO.	GRID NO.	PART NO.	GRID NO.	PART NO.	GRID NO.	PART NO.	GRID NO.
91808-16023	B - 2	93306-00431	C - 12	94701-00411	B - 2	95701-06500	E - 9	99530-10116	C - 5		
91812-16001	C - 6	93306-07202	E - 5	95024-06010	C - 5	95707-06500	F - 2	99530-14016	C - 5		
91A20-05140	D - 5	93306-20335	B - 4	95027-06008	F - 5	95707-08500	B - 2	9Y58A-76113	E - 6		
91A21-05125	D - 5	93306-20532	C - 12	95027-06010	B - 2		D - 2				
92017-05008	E - 14	93306-20593	C - 12		D - 6		E - 6				
92017-05012	F - 3	93306-27205	E - 5		E - 14	95804-06010	C - 4				
92017-10060	D - 2	93306-30633	B - 4		F - 4	95804-06016	C - 4				
92907-05100	E - 13	93306-90403	E - 3	95027-06012	B - 9	95817-08016	D - 3				
92907-06600	B - 7	93306-90501	C - 14		B - 11	95817-08020	C - 4				
92907-08200	E - 4	93310-212R6	C - 9		C - 11	95817-10055	D - 2				
92990-10200	E - 10	93310-22037	C - 9		D - 3	95817-10160	D - 2				
93101-14164	C - 6	93310-63417	B - 4		E - 7	95827-06010	B - 9				
93102-12106	B - 8	93311-62574	B - 4	95027-06016	C - 5		E - 15				
93102-12224	C - 10	93315-32053	D - 7		C - 6	95827-06012	E - 4				
	C - 15	93315-32056	D - 6		D - 14	95827-06014	F - 8				
	F - 8	93317-11287	C - 10		E - 7	95827-06016	B - 13				
93102-18278	C - 8	93317-22262	D - 6	95027-06020	B - 11		D - 5				
93102-26468	E - 3	93332-00068	D - 10		B - 13	95827-08012	D - 2				
93102-32480	C - 12	93332-00081	D - 10		C - 6	97007-05016	F - 3				
93106-22019	D - 6	93340-21505	C - 10		C - 15		F - 8				
93106-30044	E - 5	93342-22217	D - 6		F - 4	97027-06016	B - 7				
93106-30045	E - 5	93410-20038	C - 8	95027-06025	B - 7	97706-40530	F - 2				
93109-11073	B - 8	93420-18082	B - 4		B - 9	97707-30512	B - 13				
93109-20076	D - 6	93440-10085	C - 10		B - 10	97707-50516	B - 13				
93109-28043	D - 6	93440-10153	B - 2		E - 13	97707-60016	D - 4				
93210-07003	B - 11		B - 10	95027-06030	B - 8	97780-40010	F - 2				
93210-07135	B - 11	93440-25084	C - 12		C - 6	97801-03008	D - 14				
93210-08001	D - 3	93440-28062	C - 12	95027-06035	B - 3	98502-04012	B - 14				
93210-09008	B - 11	93440-41178	B - 7	95027-06040	C - 6	98507-04014	F - 3				
93210-10197	B - 10	93503-08007	C - 7	95027-06050	D - 6	98507-05008	E - 13				
	C - 5	93507-32009	C - 8	95027-06065	B - 11	98507-05010	E - 11				
93210-11073	E - 10	93511-32027	C - 10	95027-06080	C - 7	98507-05020	E - 8				
93210-12759	B - 11	93603-16219	B - 10	95027-08012	D - 3		F - 8				
93210-14369	C - 6	93604-10011	B - 8		E - 14	98507-06025	C - 5				
93210-16500	B - 9	93608-33002	C - 15	95027-08020	E - 4	98706-04012	E - 9				
93210-17570	C - 8	93612-16254	B - 3	95027-08035	D - 10	98707-06025	D - 14				
93210-19123	C - 6	9383E-14215	C - 13	95027-08040	D - 2	98907-06025	D - 14				
93210-19758	B - 8	9383E-15082	C - 13		D - 10	98980-06008	C - 4				
93210-21276	F - 4	94108-21008	E - 3	95027-08065	D - 2	99001-08600	B - 10				
93210-22164	C - 12	94111-18008	E - 5	95027-10016	C - 5	99009-12400	B - 10				
93210-25711	E - 13	94212-18188	E - 5	95027-10020	E - 10	99009-16400	C - 8				
93210-27370	C - 6	94227-21101	E - 3	95607-05100	F - 3	99009-20400	C - 8				
93210-44678	E - 13	94309-18146	E - 5		F - 8	99009-22500	C - 6				
93210-47675	B - 11	94309-21161	E - 3	95607-06100	F - 3	99009-45500	E - 5				
93210-57428	C - 6	94416-21003	E - 3	95607-10200	D - 8	99530-08012	B - 10				
93300-60804	D - 2	94421-18610	E - 5	95617-06635	B - 2	99530-08016	C - 6				
93306-00105	B - 8	94591-57118	B - 7	95617-08620	B - 2	99530-10114	B - 10				
93306-00426	C - 12	94681-76021	E - 6	95617-10100	E - 10		C - 5				