

# PARTS CATALOGUE

**WR450FT** (5TJ8) U.S.A.

**WR450F** (5TJ9) EUROPE

**WR450FT** (5TJA) CANADA, OCEANIA, SOUTH AFRICA

WR450FT/WR450T  
PARTS CATALOGUE  
©2004 by Yamaha Motor Co., Ltd.  
1st edition, September 2004  
All rights reserved.  
Any reprinting or unauthorized use  
without the written permission of  
Yamaha Motor Co., Ltd.  
is expressly prohibited.  
Printed in Japan.

**A3**

**WR450FT/WR450F**



**A4**

# FOREWORD

This Parts Catalogue is related to the parts for the model(s) on the cover page. When you are ordering replacement parts, please refer to this Parts Catalogue and quote both part numbers and part names correctly.

1. Modifications or additions which have been made after the issue of the Parts Catalogue will be announced in the Parts News.

It is advisable that you make the necessary corrections to the Parts Catalogue according to the Parts News.

2. Abbreviations

The following abbreviations are used in this Parts Catalogue.

“UR” Use specified parts number.

“UN” Use as many as needed.

“AP” Alternate Parts

“LM” Locally Made (Parts need to be ordered locally)

“F#” Frame No. (Applicable machine No.)

“O/S” Over Size

3. The number of components for assembly

- Parts, which are to be supplied in an assembly, are listed with a dot (.) in front of the part name as shown below.
- The numeral appearing to the right of each component part indicates the quantity of parts for each assembly unit.

PART NO.	DESCRIPTION	Q'TY	REMARKS
2F5-83310-60	FRONT FLASHER LIGHT ASSY	2	
115-83311-60	.BULB (6V-18W)	1	

4. Applicable colours of graphics are represented in the “REMARKS” as shown below.

PART NO.	DESCRIPTION	Q'TY	REMARKS
2N4-24110-00-X5	FUEL TANK COMP.	2	MXR
3J1-24240-10	.GRAPHIC, FUEL TANK	1	FOR MXR

5. Note that the illustrations for reference in finding parts numbers are not to be used for assembling. When assembling, please use the applicable service manual.

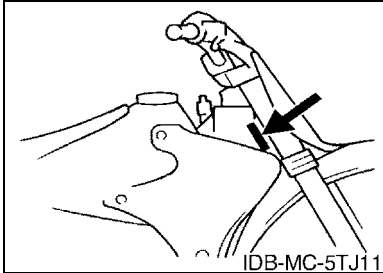
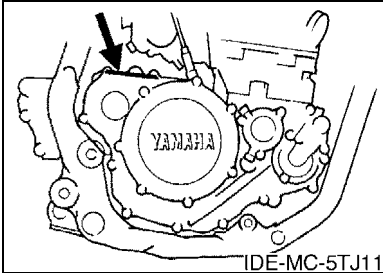
6. The asterisk (\*) before a reference number indicates modified items after the first edition.

# FOREWORD

7. Applicable Serial No.

Engine Serial No.

Frame Serial No.



8. Applicable Colour Code (The (\*) mark shows Model colour.)

Abbreviation	Colour Name	Colour Code
DPBSE(*)	DEEP PURPLISH BLUE SOLID E	0583



# CONTENTS

## ENGINE

CYLINDER .....	B2
CRANKSHAFT & PISTON .....	B4
VALVE .....	B5
CAMSHAFT & CHAIN .....	B7
WATER PUMP .....	B8
RADIATOR & HOSE .....	B9
OIL PUMP .....	B10
OIL CLEANER .....	B11
INTAKE .....	B12
CARBURETOR .....	B14
AIR INDUCTION SYSTEM .....	C4
EXHAUST .....	C5
CRANKCASE .....	C6
CRANKCASE COVER 1 .....	C7
STARTER .....	C9
STARTER CLUTCH .....	C10
CLUTCH .....	C11
TRANSMISSION .....	C12
SHIFT CAM & FORK .....	C14
SHIFT SHAFT .....	C15

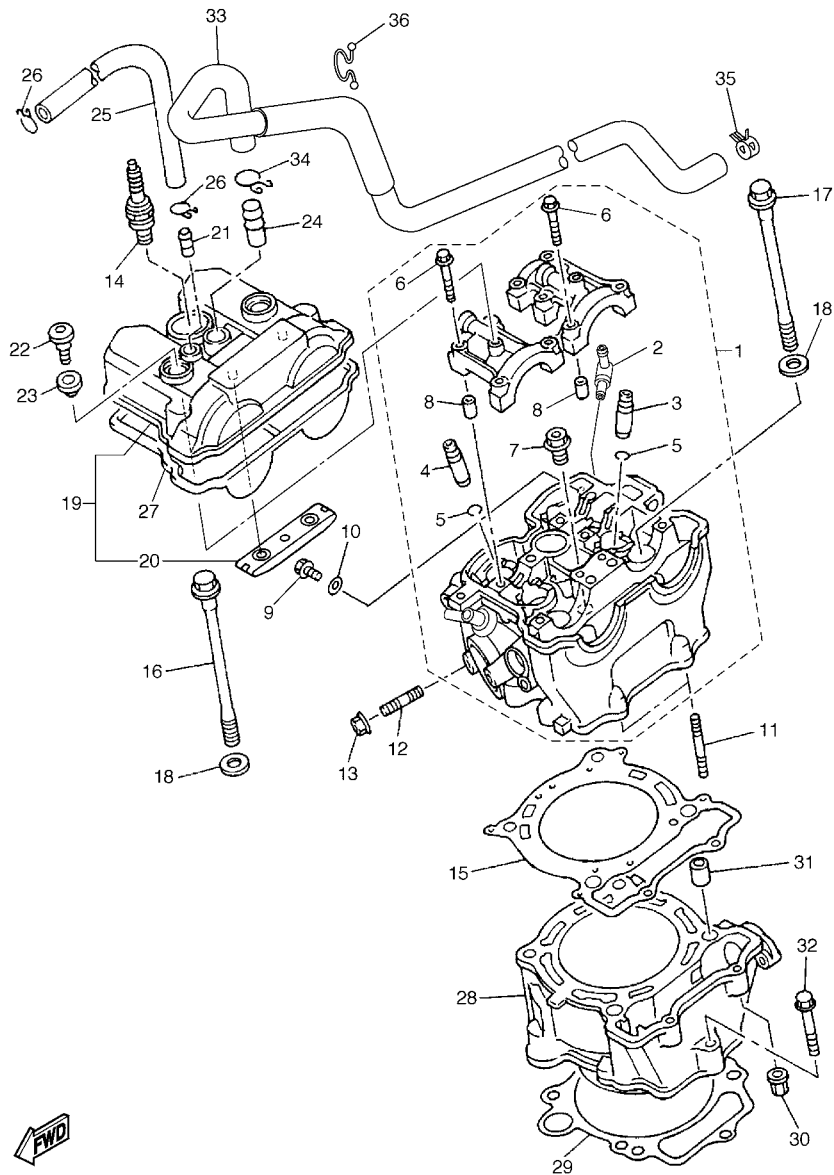
## CHASSIS

FRAME .....	D2
FENDER .....	D4
SIDE COVER .....	D5
REAR ARM .....	D6
REAR SUSPENSION .....	D8
STEERING .....	D10
FRONT FORK .....	D11
FUEL TANK .....	D14
SEAT .....	E2
FRONT WHEEL .....	E3
FRONT BRAKE CALIPER .....	E4
REAR WHEEL .....	E5
REAR BRAKE CALIPER .....	E7
STEERING HANDLE & CABLE .....	E8
FRONT MASTER CYLINDER .....	E9
STAND & FOOTREST .....	E10
REAR MASTER CYLINDER .....	E12
GENERATOR .....	E13
STARTING MOTOR .....	E14

METER .....	E15
HEADLIGHT .....	F2
TAILLIGHT .....	F3
HANDLE SWITCH & LEVER .....	F4
ELECTRICAL 1 .....	F5
ALTERNATE FOR CHASSIS .....	F7

## INDEX

NUMERICAL INDEX .....	M1
-----------------------	----



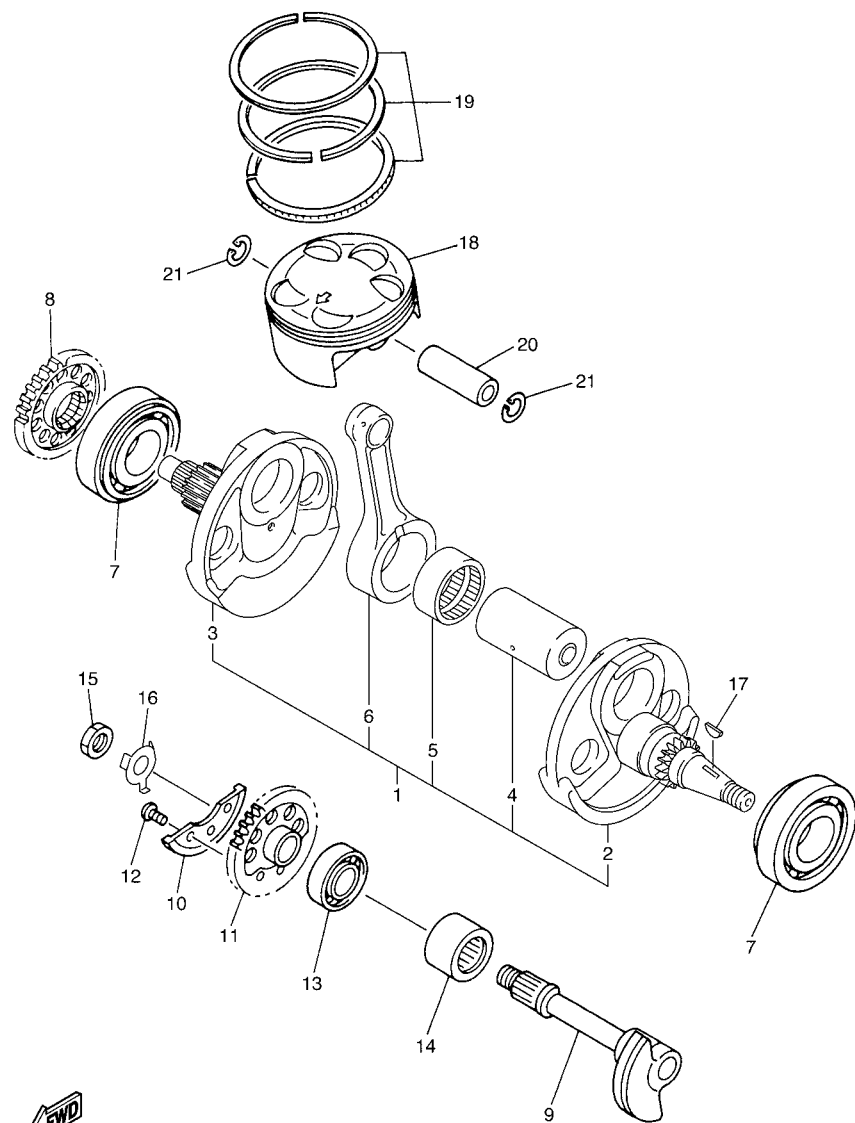
5TJ8100-D010

FIG. 1 CYLINDER

REF. NO.	PART NO.	DESCRIPTION	5TJ8	5TJ9	5TJA	REMARKS
1	5TJ-11101-00	CYLINDER HEAD ASSY	1	1	1	
2	353-13115-01	.CONNECTOR, SUCTION PIPE	1	1	1	
3	5TA-11133-10	.GUIDE, VALVE 1	3	3	3	
4	5TA-11134-10	.GUIDE, VALVE 2	2	2	2	
5	93440-10153	.CIRCLIP	5	5	5	
6	90105-06027	.BOLT, FLANGE	10	10	10	
7	90340-12112	.PLUG, STRAIGHT SCREW	1	1	1	
8	91808-16023	.PIN, DOWEL	4	4	4	
9	95027-06010	BOLT, FLANGE	1	1	1	
10	90430-06014	GASKET	1	1	1	
11	95617-06635	BOLT, STUD	2	2	2	
12	95617-08620	BOLT, STUD	1	1	1	
13	95707-08500	NUT, FLANGE	1	1	1	
14	94701-00411	PLUG, SPARK (NGK R CR8E)	1	1	1	
15	5TA-11181-00	GASKET, CYLINDER HEAD 1	1	1	1	
16	90105-104A7	BOLT, FLANGE	2	2	2	
17	90105-106A3	BOLT, FLANGE	2	2	2	
18	90201-10025	WASHER, PLATE	4	4	4	
19	5TG-11190-10	COVER, CYLINDER HEAD 1	1	1	1	
20	5BE-12241-00	.GUIDE, STOPPER 2	1	1	1	
21	5BE-11167-00	PIPE, BREATHER 2	1	1	1	
22	90109-066F0	BOLT	2	2	2	
23	4KG-1111G-00	RUBBER, MOUNT 1	2	2	2	
24	371-11167-01	PIPE, BREATHER 2	1	1	1	
25	90445-112K0	HOSE (L285)	1	1	1	
26	90467-11106	CLIP	2	2	2	
27	5TA-11193-00	GASKET, HEAD COVER 1	1	1	1	



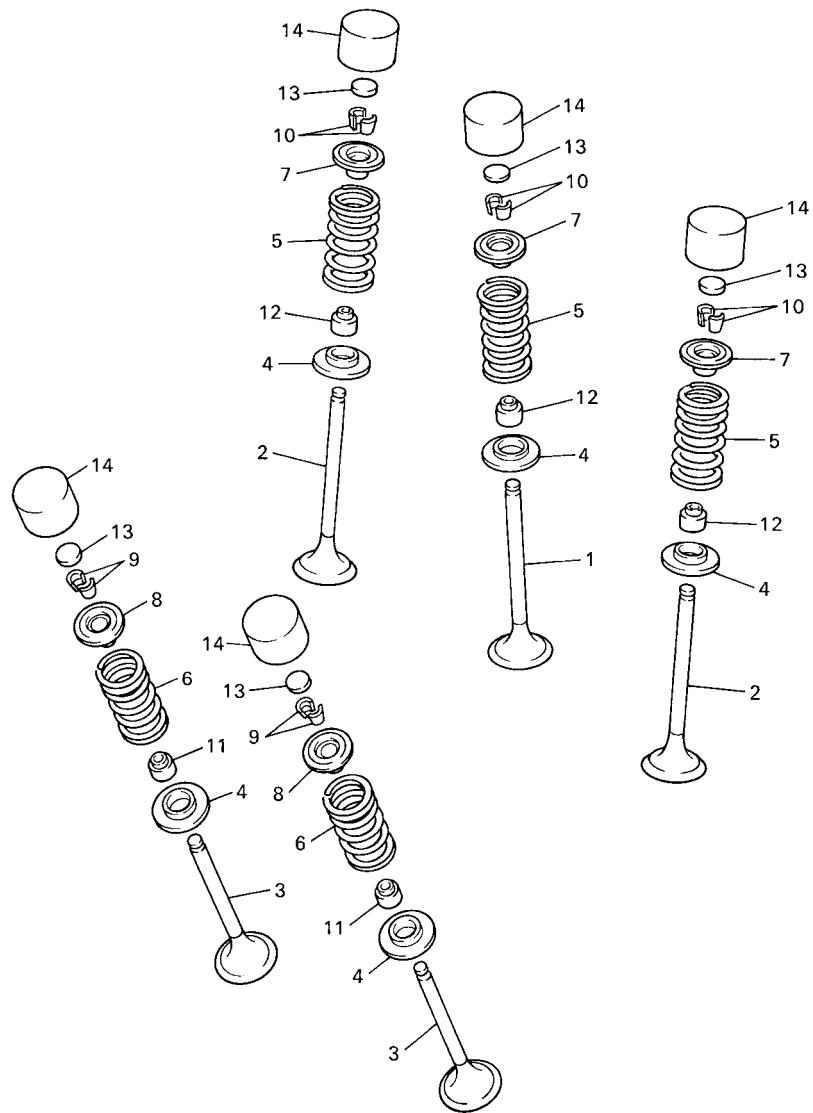




5TA1100-B020

FIG. 2 CRANKSHAFT & PISTON

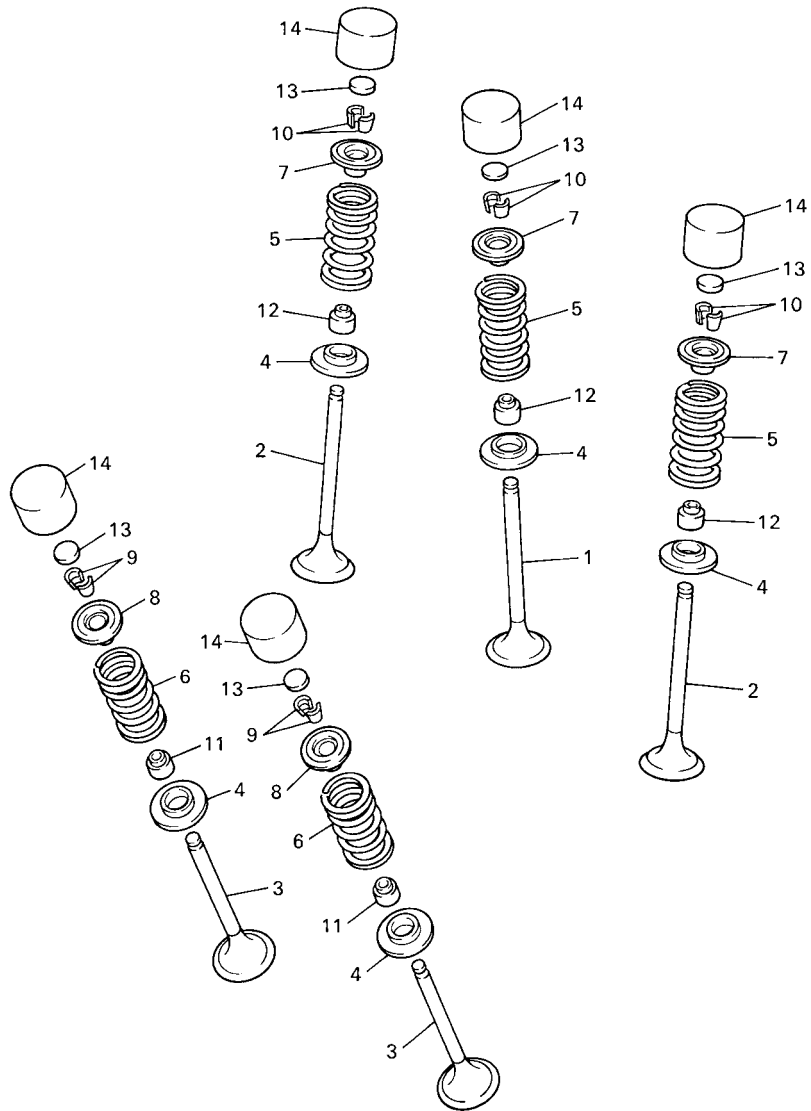
REF. NO.	PART NO.	DESCRIPTION	5TJ8	5TJ9	5TJA	REMARKS
1	5TJ-11400-10	CRANKSHAFT ASSY	1	1	1	
2	5TJ-11412-10	.CRANK 1	1	1	1	
3	5TA-11422-00	.CRANK 2	1	1	1	
4	5TA-11681-00	.PIN, CRANK 1	1	1	1	
5	93310-63417	.BEARING	1	1	1	
6	5XD-11651-00	.ROD, CONNECTING	1	1	1	
7	93306-30633	BEARING	2	2	2	
8	5TA-11536-00	GEAR, DRIVE	1	1	1	
9	5TA-11455-11	SHAFT 1	1	1	1	
10	5BE-11454-00	WEIGHT 1	1	1	1	
11	5TA-11531-01	GEAR, BALANCE WEIGHT	1	1	1	
12	90149-06250	SCREW	3	3	3	
13	93306-20335	BEARING	1	1	1	
14	93311-62574	BEARING	1	1	1	
15	90170-14171	NUT	1	1	1	
16	90215-14287	WASHER, LOCK	1	1	1	
17	90280-03006	KEY, WOODRUFF	1	1	1	
18	5TJ-11631-00	PISTON (STD)	1	1	1	
19	5JG-11603-00	PISTON RING SET (STD)	1	1	1	
20	5TA-11633-00	PIN, PISTON	1	1	1	
21	93420-18082	CIRCLIP	2	2	2	



5BE100-8030

FIG. 3 VALVE

REF. NO.	PART NO.	DESCRIPTION	5TJ8	5TJ9	5TJA	REMARKS
1	5TA-12111-00	VALVE, INTAKE	1	1	1	
2	5TA-12112-00	VALVE, INTAKE 2	2	2	2	
3	5TA-12121-00	VALVE, EXHAUST	2	2	2	
4	3GM-12126-00	SEAT, VALVE SPRING 2	5	5	5	
5	5TA-12113-00	SPRING, VALVE INNER	3	3	3	
6	5TA-12114-00	SPRING, VALVE OUTER	2	2	2	
7	5BE-12117-00	RETAINER, VALVE SPRING	3	3	3	
8	4GY-12117-00	RETAINER, VALVE SPRING	2	2	2	
9	1AA-12118-00	COTTER, VALVE	4	4	4	
10	1WG-12118-00	COTTER, VALVE	6	6	6	
11	33M-12119-00	SEAL, VALVE STEM	2	2	2	
12	4SV-12119-00	SEAL, VALVE STEM	3	3	3	
13	3LD-12168-00	PAD, ADJUSTING (1.20)	5	5	5	UR
	3LD-12168-20	PAD, ADJUSTING (1.25)	5	5	5	UR
	3LD-12168-40	PAD, ADJUSTING (1.30)	5	5	5	UR
	3LD-12168-60	PAD, ADJUSTING (1.35)	5	5	5	UR
	3LD-12168-80	PAD, ADJUSTING (1.40)	5	5	5	UR
	3LD-12168-A0	PAD, ADJUSTING (1.45)	5	5	5	UR
	3LD-12168-F0	PAD, ADJUSTING (1.50)	5	5	5	UR
	3LD-12168-H1	PAD, ADJUSTING (1.55)	5	5	5	UR
	3LD-12168-K1	PAD, ADJUSTING (1.60)	5	5	5	UR
	3LD-12168-M1	PAD, ADJUSTING (1.65)	5	5	5	UR
	3LD-12168-R1	PAD, ADJUSTING (1.70)	5	5	5	UR
	3LD-12168-U1	PAD, ADJUSTING (1.75)	5	5	5	UR
	3LD-12168-W1	PAD, ADJUSTING (1.80)	5	5	5	UR
	3LD-12168-Y1	PAD, ADJUSTING (1.85)	5	5	5	UR
	3LD-12169-11	PAD, ADJUSTING (1.90)	5	5	5	UR

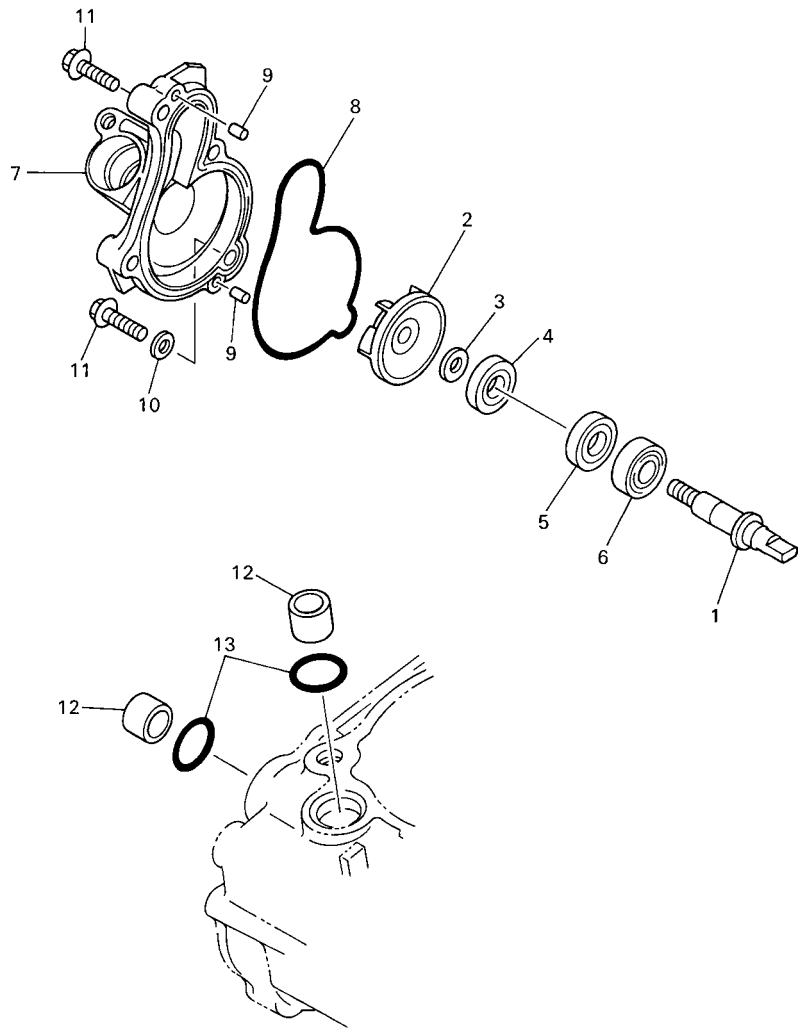


5BE100-8030

FIG. 3 VALVE

REF. NO.	PART NO.	DESCRIPTION	5TJ8	5TJ9	5TJA	REMARKS
13	3LD-12169-31	PAD, ADJUSTING (1.95)	5	5	5	UR
	3LD-12169-50	PAD, ADJUSTING (2.00)	5	5	5	UR
	3LD-12169-70	PAD, ADJUSTING (2.05)	5	5	5	UR
	3LD-12169-90	PAD, ADJUSTING (2.10)	5	5	5	UR
	3LD-12169-E0	PAD, ADJUSTING (2.15)	5	5	5	UR
	3LD-12169-G0	PAD, ADJUSTING (2.20)	5	5	5	UR
	3LD-12169-J0	PAD, ADJUSTING (2.25)	5	5	5	UR
	3LD-12169-L0	PAD, ADJUSTING (2.30)	5	5	5	UR
	3LD-12169-N0	PAD, ADJUSTING (2.35)	5	5	5	UR
	3LD-12169-T0	PAD, ADJUSTING (2.40)	5	5	5	UR
14	3FV-12153-10	LIFTER, VALVE	5	5	5	YELLOW





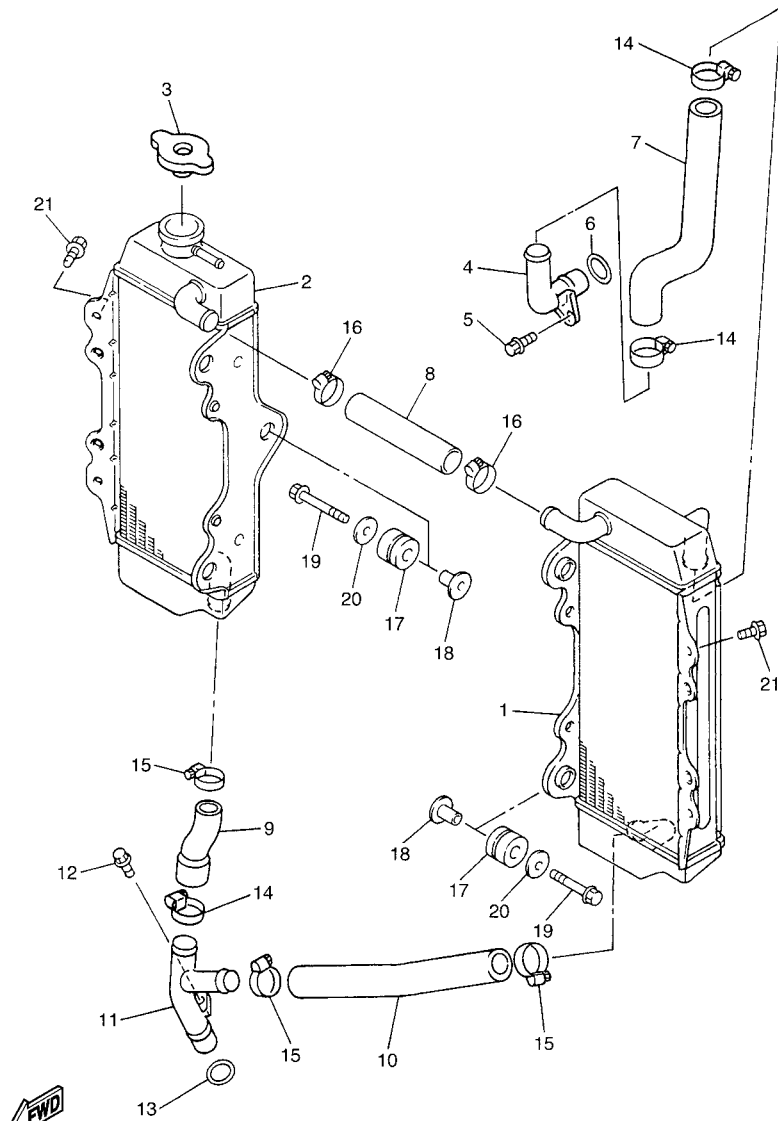
**FIG. 5 WATER PUMP**

REF. NO.	PART NO.	DESCRIPTION	5TJ8	5TJ9	5TJA	REMARKS
1	5GR-12458-00	SHAFT, IMPELLER	1	1	1	
2	5DJ-12451-00	IMPELLER, WATER PUMP	1	1	1	
3	90201-08512	WASHER, PLATE	1	1	1	
4	93109-11073	OIL SEAL	1	1	1	
5	93102-12106	OIL SEAL (SD 12-22-5 HS)	1	1	1	
6	93306-00105	BEARING (B6001)	1	1	1	
7	5BE-12422-20	COVER, HOUSING	1	1	1	
8	5BE-12439-00	O-RING	1	1	1	
9	93604-10011	PIN, DOWEL	2	2	2	
10	90430-06014	GASKET	1	1	1	
11	95027-06030	BOLT, FLANGE	4	4	4	
12	5BE-12564-00	PIPE, WATER	2	2	2	
13	93210-19758	O-RING	2	2	2	



5BE100-8050

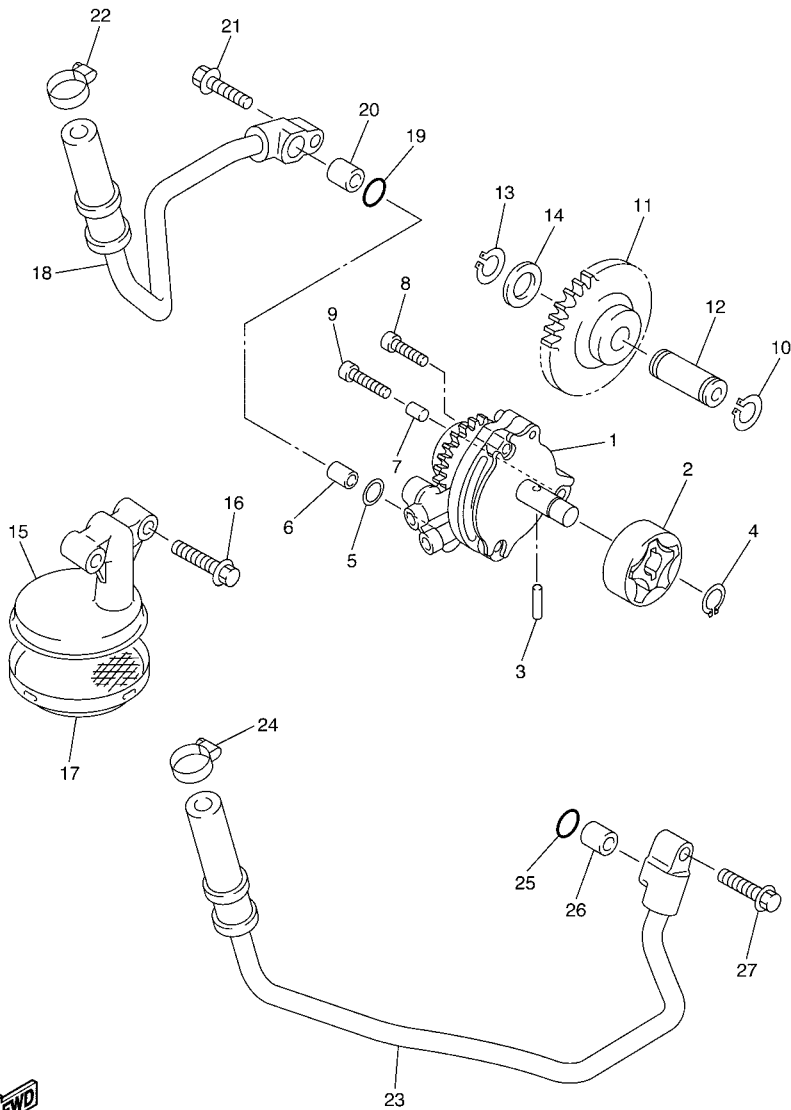
**FIG. 6 RADIATOR & HOSE**



5TJ1100-B060

REF. NO.	PART NO.	DESCRIPTION	5TJ8	5TJ9	5TJA	REMARKS
1	5TA-1240A-00	RADIATOR ASSY	1	1	1	
2	5TA-12461-00	RADIATOR ASSY	1	1	1	
3	5HD-12462-00	CAP, RADIATOR	1	1	1	
4	5TA-12481-00	PIPE 1	1	1	1	
5	91317-06012	BOLT	1	1	1	
6	93210-16500	O-RING	1	1	1	
7	5TA-12576-00	HOSE 1	1	1	1	
8	5SG-12579-00	HOSE 4	1	1	1	
9	5TA-12578-00	HOSE 3	1	1	1	
10	5TA-12579-00	HOSE 4	1	1	1	
11	5TA-12482-00	PIPE 2	1	1	1	
12	95027-06012	BOLT, FLANGE	1	1	1	
13	93210-16500	O-RING	1	1	1	
14	90450-28014	HOSE CLAMP ASSY	3	3	3	
15	90450-25037	HOSE CLAMP ASSY	3	3	3	
16	90450-22017	HOSE CLAMP ASSY	2	2	2	
17	90480-15528	GROMMET	6	6	6	
18	90387-06065	COLLAR	6	6	6	
19	95027-06025	BOLT, FLANGE	6	6	6	
20	90201-06571	WASHER, PLATE	6	6	6	
21	95827-06010	BOLT, FLANGE	2	2	2	

FIG. 7 OIL PUMP



5TA1100-B070

REF. NO.	PART NO.	DESCRIPTION	5TJ8	5TJ9	5TJA	REMARKS
1	5TA-13300-00	OIL PUMP ASSY	1	1	1	
2	5TA-13320-00	ROTOR ASSY 2	1	1	1	
3	93603-16219	PIN, DOWEL	1	1	1	
4	93440-10153	CIRCLIP	1	1	1	
5	93210-10197	O-RING	1	1	1	
6	99530-10114	PIN, DOWEL	1	1	1	
7	99530-08012	PIN, DOWEL	1	1	1	
8	90110-06058	BOLT, HEXAGON SOCKET HEAD	2	2	2	
9	91314-06030	BOLT	1	1	1	
10	99001-08600	CIRCLIP	1	1	1	
11	5TA-13341-00	GEAR, OIL PUMP IDLE	1	1	1	
12	5BE-13342-00	SHAFT, IDLE GEAR	1	1	1	
13	99009-12400	CIRCLIP	1	1	1	
14	90201-12166	WASHER, PLATE	1	1	1	
15	5TA-13412-00	HOUSING, STRAINER	1	1	1	
16	95027-06025	BOLT, FLANGE	2	2	2	
17	5BE-13411-00	STRAINER, OIL	1	1	1	
18	5TA-13464-00	HOSE, OIL 1	1	1	1	
19	93210-10197	O-RING	1	1	1	
20	99530-10114	PIN, DOWEL	1	1	1	
21	95027-06025	BOLT, FLANGE	1	1	1	
22	90450-22017	HOSE CLAMP ASSY	1	1	1	
23	5TA-13465-00	HOSE, OIL 2	1	1	1	
24	90450-22017	HOSE CLAMP ASSY	1	1	1	
25	93210-10197	O-RING	1	1	1	
26	99530-10114	PIN, DOWEL	1	1	1	
27	95027-06025	BOLT, FLANGE	1	1	1	



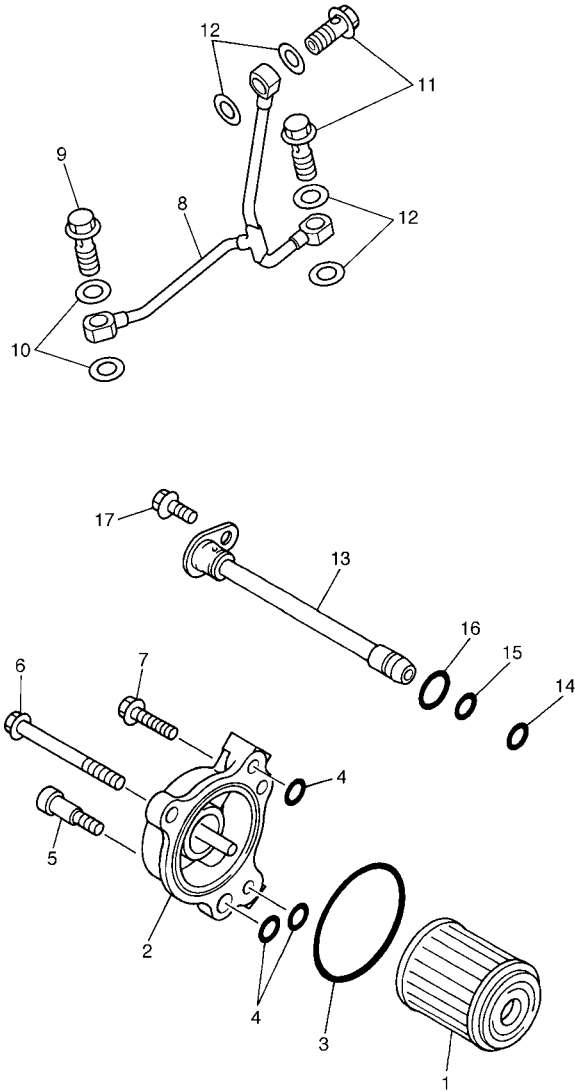


FIG. 8 OIL CLEANER

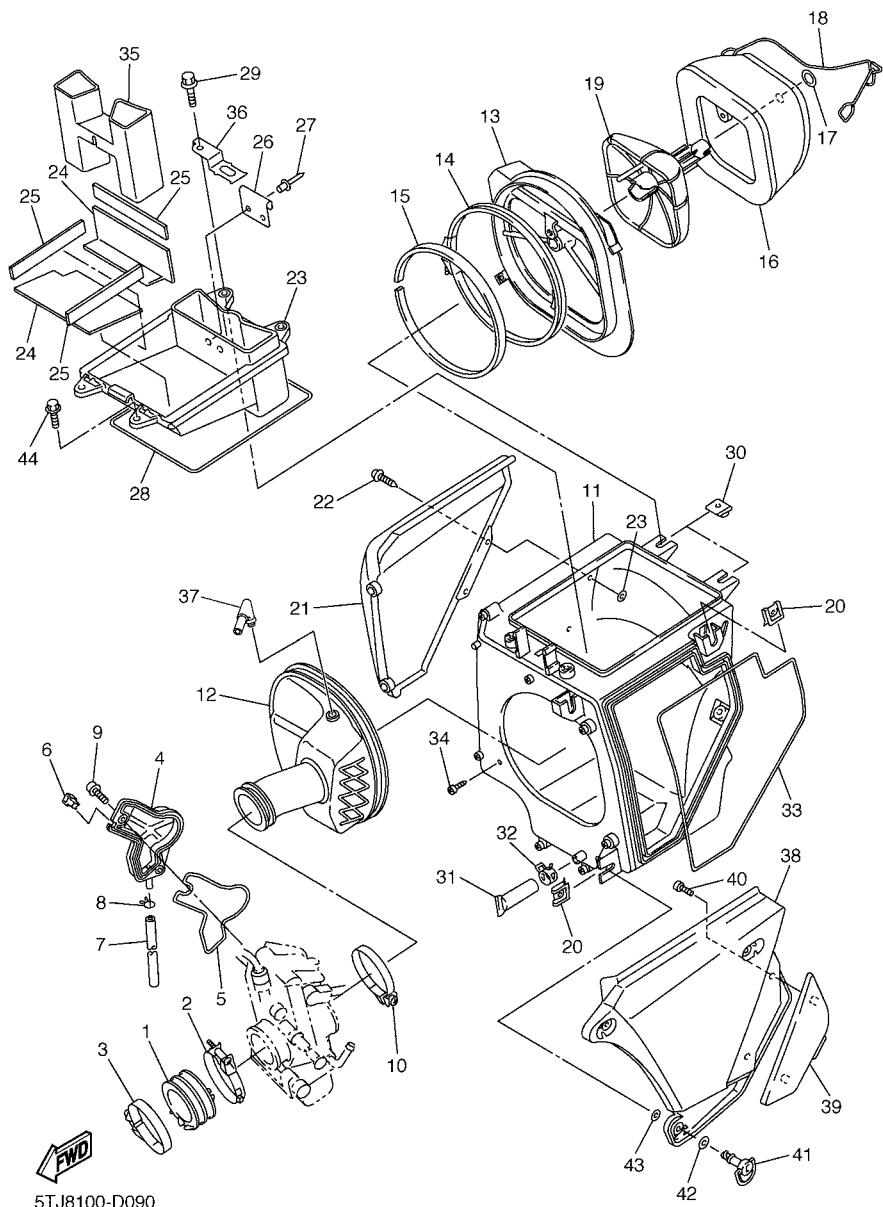
REF. NO.	PART NO.	DESCRIPTION	5TJ8	5TJ9	5TJA	REMARKS
1	5TA-13440-00	ELEMENT ASSY, OIL CLEANER	1	1	1	
2	5BE-13447-10	COVER, OIL ELEMENT	1	1	1	
3	93210-47675	O-RING	1	1	1	
4	93210-07135	O-RING	3	3	3	
5	90109-065G2	BOLT	1	1	1	
6	91317-06065	BOLT	1	1	1	
7	91317-06020	BOLT	1	1	1	
8	5TG-13161-00	PIPE, DELIVERY 1	1	1	1	
9	90401-10159	BOLT, UNION	1	1	1	
10	90430-10188	GASKET	2	2	2	
11	90401-08038	BOLT, UNION	2	2	2	
12	90430-08119	GASKET	4	4	4	
13	5TA-13171-00	PIPE, DELIVERY 2	1	1	1	
14	93210-07003	O-RING	1	1	1	
15	93210-09008	O-RING	1	1	1	
16	93210-12759	O-RING	1	1	1	
17	95027-06012	BOLT, FLANGE	1	1	1	



5XD1100-C080

**FIG. 9 INTAKE**

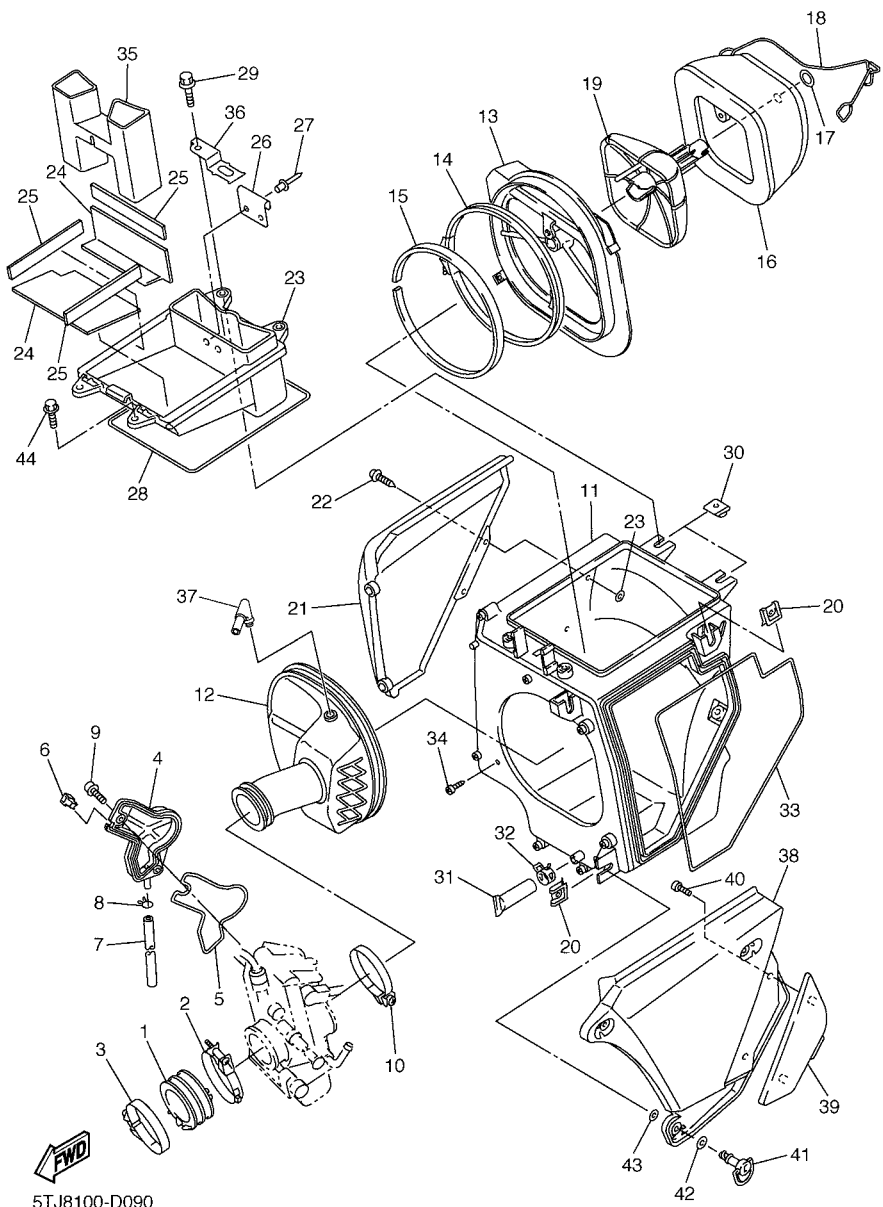
REF. NO.	PART NO.	DESCRIPTION	5TJ8	5TJ9	5TJA	REMARKS
1	5XD-13597-10	JOINT, CARBURETOR 3	1	1	1	
2	90450-57009	HOSE CLAMP ASSY	1	1	1	
3	90450-59002	HOSE CLAMP ASSY	1	1	1	
4	5TA-14293-00	COVER 1	1	1	1	
5	5TA-14227-00	GASKET	1	1	1	
6	5TA-14239-00	SEAL	1	1	1	
7	5TA-14987-00	HOSE	1	1	1	
8	3TJ-14137-40	CLIP	1	1	1	
9	5TA-14428-00	BOLT	2	2	2	
10	90450-61001	HOSE CLAMP ASSY	1	1	1	
11	5TJ-14401-20	AIR CLEANER CASE ASSY	1	1	1	
12	5TJ-14453-00	JOINT, AIR CLEANER 1	1	1	1	
13	5TJ-14459-00	HOLDER, GUIDE	1	1	1	
14	5NY-14455-10	BAND	1	1	1	
15	5NY-14442-00	SPACER	1	1	1	
16	5TJ-14451-00	ELEMENT, AIR CLEANER	1	1	1	
17	5TJ-14475-00	WASHER	1	1	1	
18	5TJ-1441G-00	BINDER 1	1	1	1	
19	5TJ-14458-00	GUIDE	1	1	1	
20	4XV-2177L-01	PLATE, SPRING	3	3	3	
21	5TJ-1441E-10	COVER, CLEANER CASE 2	1	1	1	
22	97707-40016	SCREW, TAPPING	2	2	2	
23	5TJ-14437-10	DUCT	1	1	1	
24	5TJ-14425-10	DAMPER 1	2	2	2	
25	5TJ-14426-00	DAMPER 2	3	3	3	
26	5TJ-14436-00	HOOK	1	1	1	
27	90267-32146	RIVET, BLIND	2	2	2	



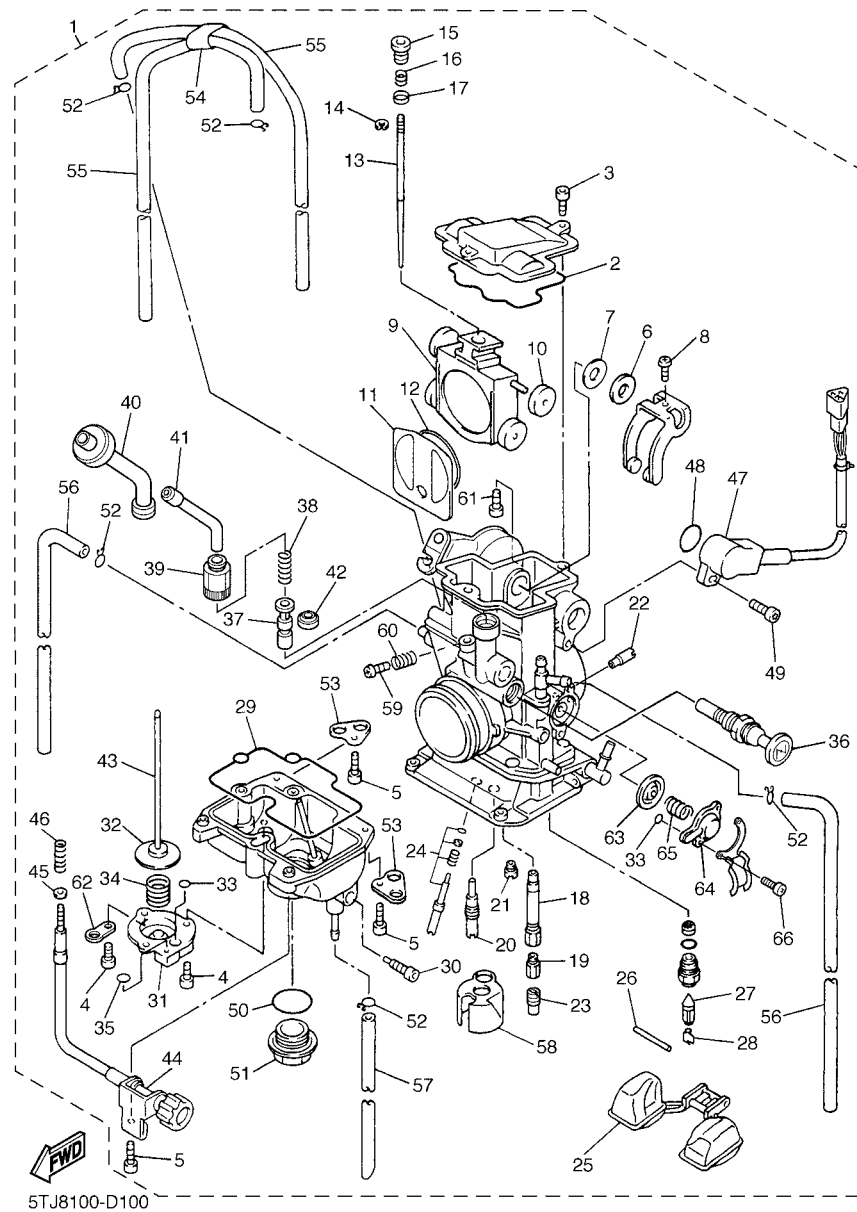
5TJ8100-D090

**FIG. 9 INTAKE**

REF. NO.	PART NO.	DESCRIPTION	5TJ8	5TJ9	5TJA	REMARKS
28	5TJ-14457-00	SEAL	1	1	1	
29	95027-06020	BOLT, FLANGE	2	2	2	
30	90183-06023	NUT, SPRING	2	2	2	
31	5BF-1443E-00	PIPE, DRAIN	1	1	1	
32	90467-17089	CLIP	1	1	1	
33	5TJ-14462-00	SEAL	1	1	1	
34	97707-50516	SCREW, TAPPING	1	1	1	
35	5TJ-1443A-00	DUCT	1	1	1	
36	5TJ-81953-00	STAY, RELAY	1	1	1	
37	5TJ-14419-00	PIPE	1	1	1	
38	5TJ-1441A-00	COVER, CLEANER CASE 1	1	1	1	
39	5TJ-1442A-00	COVER, CLEANER CASE 3	1	1	1	
40	97707-30512	SCREW, TAPPING	2	2	2	
41	3FV-28386-00	HEAD	3	3	3	
42	2TK-21757-00	WASHER, SPECIAL 1	3	3	3	
43	5TJ-21757-00	WASHER, SPECIAL 1	3	3	3	
44	95827-06016	BOLT, FLANGE	2	2	2	



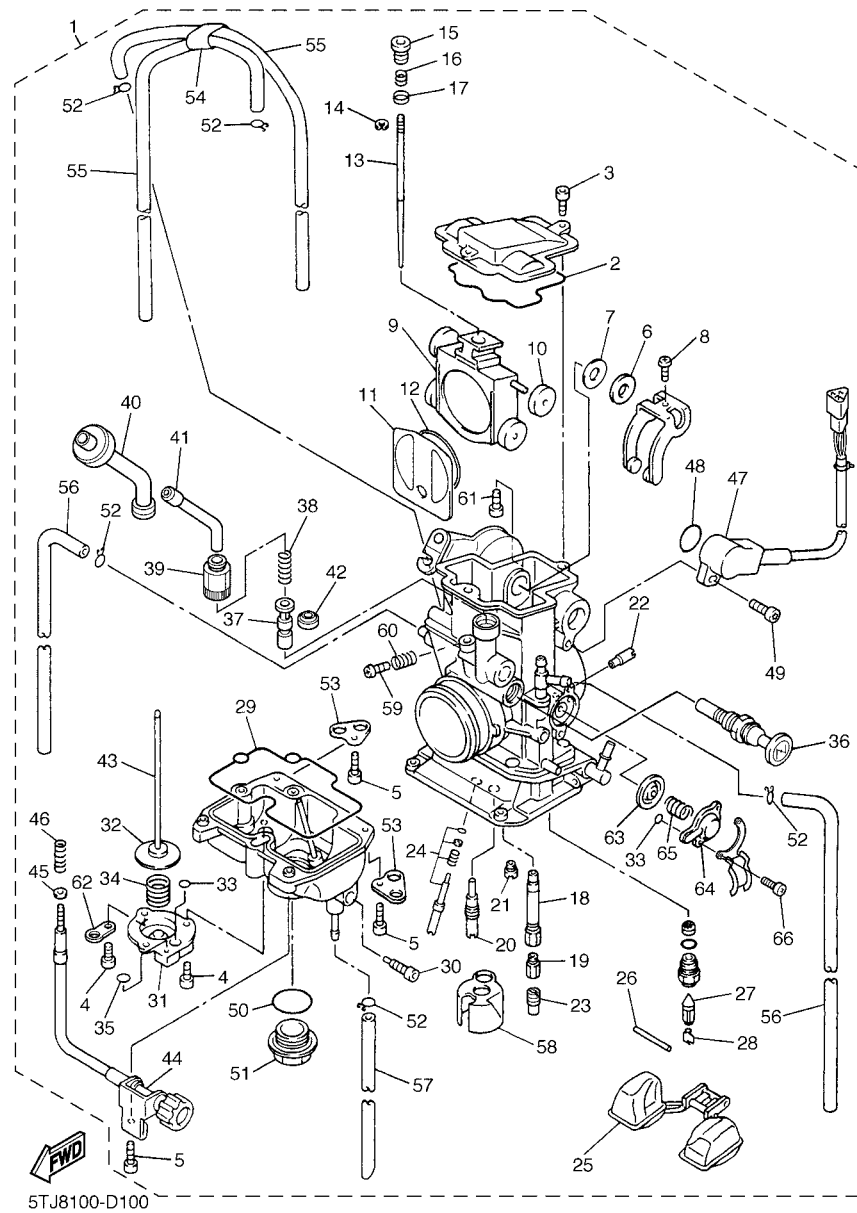
5TJ8100-D090



5TJ8100-D100

FIG. 10 CARBURETOR

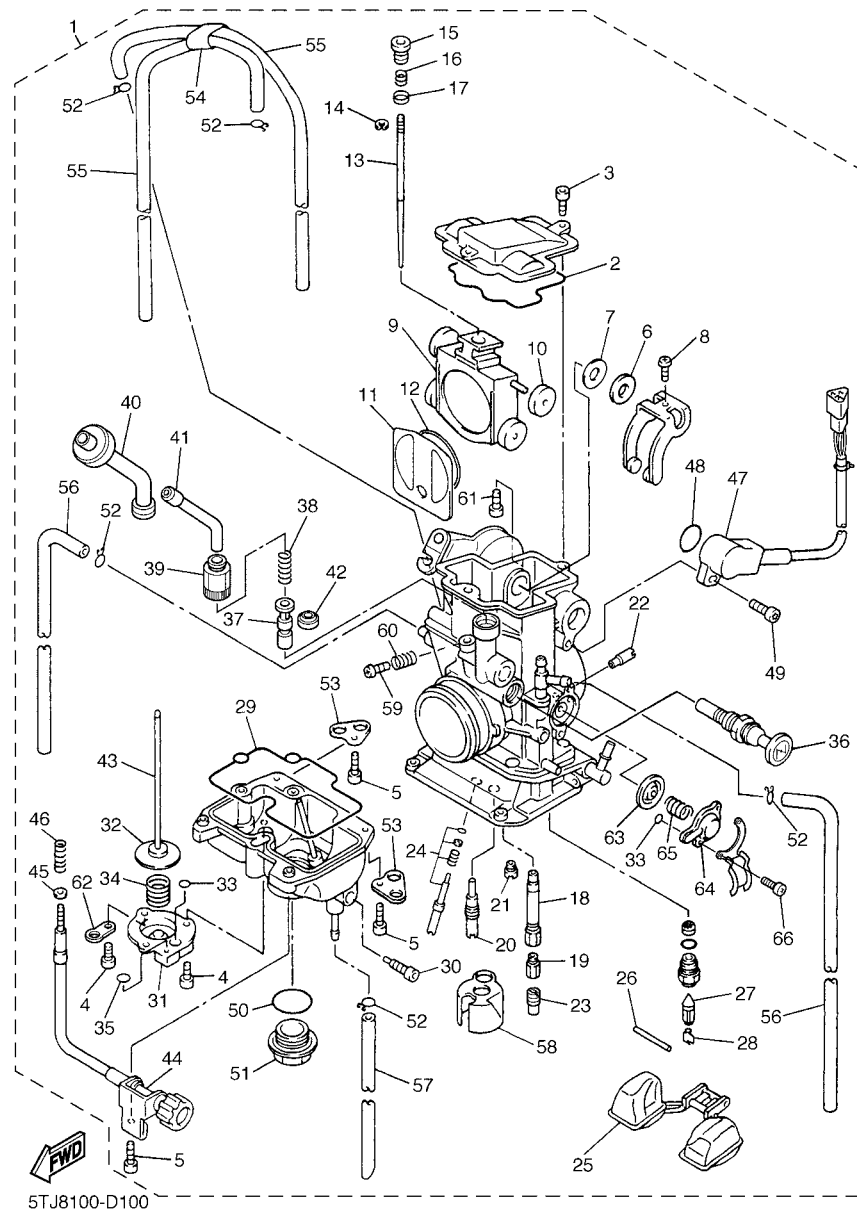
REF. NO.	PART NO.	DESCRIPTION	5TJ8	5TJ9	5TJA	REMARKS
1	5TJ-14101-80	CARBURETOR ASSY 1	1	1	1	
2	5JG-14959-00	.GASKET	1	1	1	
3	91316-04012	.BOLT	2	2	2	
4	688-14592-00	.SCREW	3	3	3	
5	98502-04012	.SCREW, PAN HEAD	4	4	4	
6	90202-08045	.WASHER, PLATE	1	1	1	
7	5JG-14951-00	.WASHER	1	1	1	
8	5JG-14522-00	.SCREW, ADJUST	1	1	1	
9	5JG-14388-00	.VALVE, VACUUM CONTROL	1	1	1	
10	3TJ-14267-40	.ROLLER	1	1	1	
11	5JG-14546-01	.VALVE, NEEDLE	1	1	1	
12	4FN-14997-00	.SEAL	1	1	1	
13	5TJ-14916-NT	.NEEDLE (#NFNT)	1	1	1	STD
	5TJ-14916-9P	.NEEDLE (#DUP-K)	1	1	1	AP
	5TJ-14916-91	.NEEDLE (#DUQ-K)	1	1	1	AP
	5TJ-14916-9R	.NEEDLE (#DUR-K)	1	1	1	AP
	5TJ-14916-9S	.NEEDLE (#DUS-K)	1	1	1	AP
	5TJ-14916-9T	.NEEDLE (#DUT-K)	1	1	1	AP
	5TJ-14916-9U	.NEEDLE (#DUU-K)	1	1	1	AP
	5TJ-14916-9V	.NEEDLE (#DUV-K)	1	1	1	AP
14	3TJ-14159-40	.CLIP	1	1	1	
15	5JG-14521-00	.SCREW, ADJUST	1	1	1	
16	5JG-14275-00	.SPRING	1	1	1	
17	5JG-14264-00	.COLLAR	1	1	1	
18	5TJ-14947-00	.JET, NEEDLE	1	1	1	
19	4MX-14943-40	.JET, MAIN (#165)	1	1	1	STD
	4MX-14943-38	.JET, MAIN (#155)	1	1	1	AP



5TJ8100-D100

FIG. 10 CARBURETOR

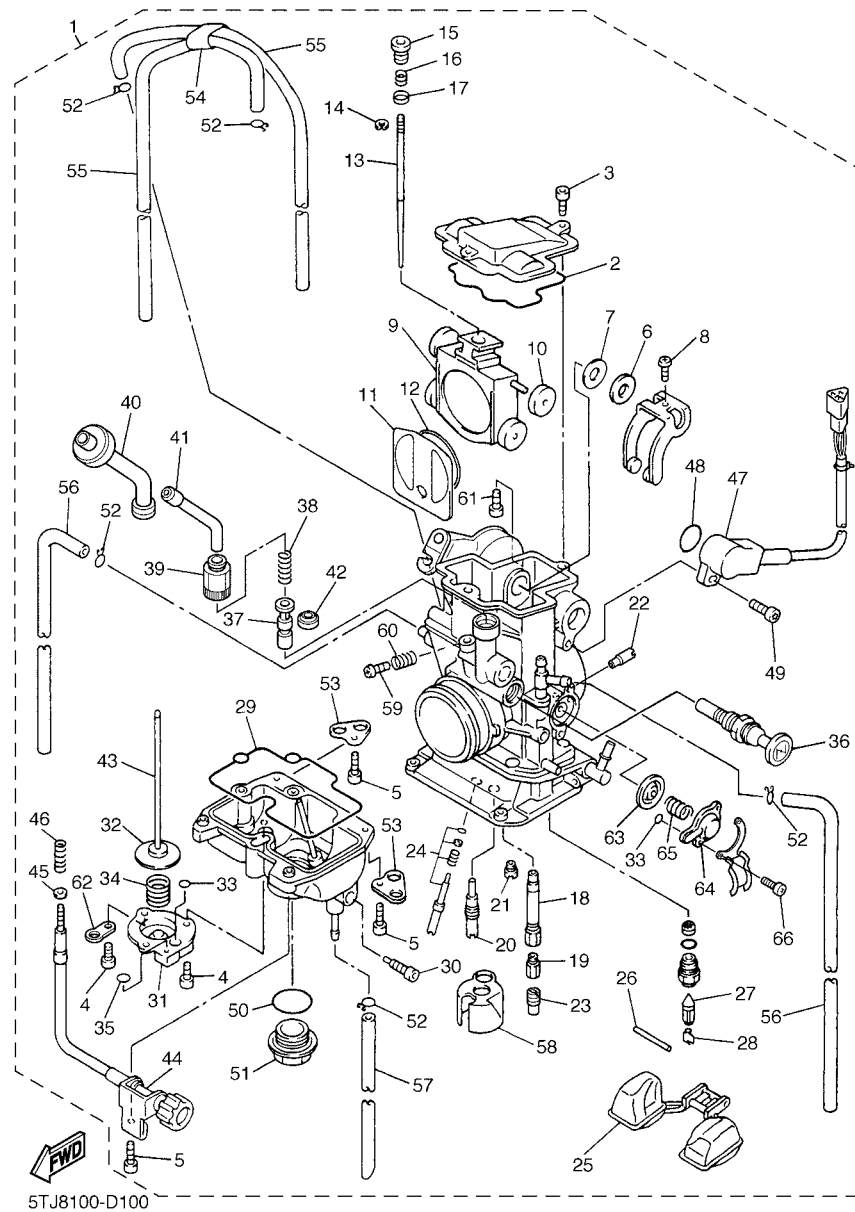
REF. NO.	PART NO.	DESCRIPTION	5TJ8	5TJ9	5TJA	REMARKS
19	4MX-14943-89	.JET, MAIN (#158)	1	1	1	AP
	4MX-14943-39	.JET, MAIN (#160)	1	1	1	AP
	4MX-14943-90	.JET, MAIN (#162)	1	1	1	AP
	4MX-14943-91	.JET, MAIN (#168)	1	1	1	AP
	4MX-14943-41	.JET, MAIN (#170)	1	1	1	AP
	4MX-14943-92	.JET, MAIN (#172)	1	1	1	AP
	4MX-14943-42	.JET, MAIN (#175)	1	1	1	AP
20	4MX-14948-05	.JET, SLOW (#45)	1	1	1	STD
	4MX-14948-03	.JET, SLOW (#40)	1	1	1	AP
	4MX-14948-04	.JET, SLOW (#42)	1	1	1	AP
	4MX-14948-06	.JET, SLOW (#48)	1	1	1	AP
	4MX-14948-07	.JET, SLOW (#50)	1	1	1	AP
21	3TJ-1494F-13	.JET (#65)	1	1	1	STD
	3TJ-1494F-11	.JET (#60)		1	1	AP
	3TJ-1494F-12	.JET (#62)		1	1	AP
	3TJ-1494F-14	.JET (#68)		1	1	AP
	3TJ-1494F-15	.JET (#70)		1	1	AP
22	5TA-14943-19	.JET, MAIN (#80)	1	1	1	
23	4JT-1494F-07	.JET (#50)	1	1	1	STD
	4JT-1494F-01	.JET (#35)	1	1	1	AP
	4JT-1494F-03	.JET (#40)	1	1	1	AP
	4JT-1494F-05	.JET (#45)	1	1	1	AP
	4JT-1494F-09	.JET (#55)	1	1	1	AP
	4JT-1494F-11	.JET (#60)	1	1	1	AP
	4JT-1494F-13	.JET (#65)	1	1	1	AP
24	5NL-14105-00	.PILOT SCREW SET	1	1	1	
25	4SR-14985-00	.FLOAT	1	1	1	



5TJ8100-D100

FIG. 10 CARBURETOR

REF. NO.	PART NO.	DESCRIPTION	5TJ8	5TJ9	5TJA	REMARKS
26	676-14548-00	.PIN, FLOAT ARM	1	1	1	
27	4MX-14392-00	.VALVE, NEEDLE	1	1	1	
28	633-14159-00	.CLIP	1	1	1	
29	5JG-14984-00	.GASKET, FLOAT CHAMBER	1	1	1	
30	3TJ-14191-40	.PLUG, DRAIN	1	1	1	
31	3TJ-14293-40	.COVER 1	1	1	1	
32	5JG-14940-18	.DIAPHRAGM ASSY	1	1	1	STD
	5JG-14940-17	.DIAPHRAGM ASSY		1	1	AP
	5JG-14940-19	.DIAPHRAGM ASSY		1	1	AP
33	3TJ-14536-40	.GASKET	2	2	2	
34	5GS-14933-40	.SPRING, DIAPHRAGM	1	1	1	
35	6H4-14561-00	.O-RING	1	1	1	
36	5TA-14171-00	.PLUNGER, STARTER	1	1	1	
37	5TA-14371-00	.PLUNGER, STARTER	1	1	1	
38	5TA-14335-00	.SPRING, PLUNGER	1	1	1	
39	5TA-14991-00	.SCREW	1	1	1	
40	5TA-14374-00	.CAP, PLUNGER	1	1	1	
41	5TA-14155-00	.GUIDE, CABLE	1	1	1	
42	5TA-14997-00	.SEAL	1	1	1	
43	5JG-14379-00	.ROD, STARTER	1	1	1	
44	5JG-14922-00	.SCREW, THROTTLE	1	1	1	
45	90201-08410	.WASHER, PLATE	1	1	1	
46	5TA-14934-00	.SPRING, THROTTLE STOP	1	1	1	
47	5TA-85885-00	.THROTTLE SENSOR ASSY	1	1	1	
48	5NX-14562-00	.O-RING	1	1	1	
49	5NX-14216-00	.SCREW	1	1	1	
50	4MX-14561-00	.O-RING	1	1	1	

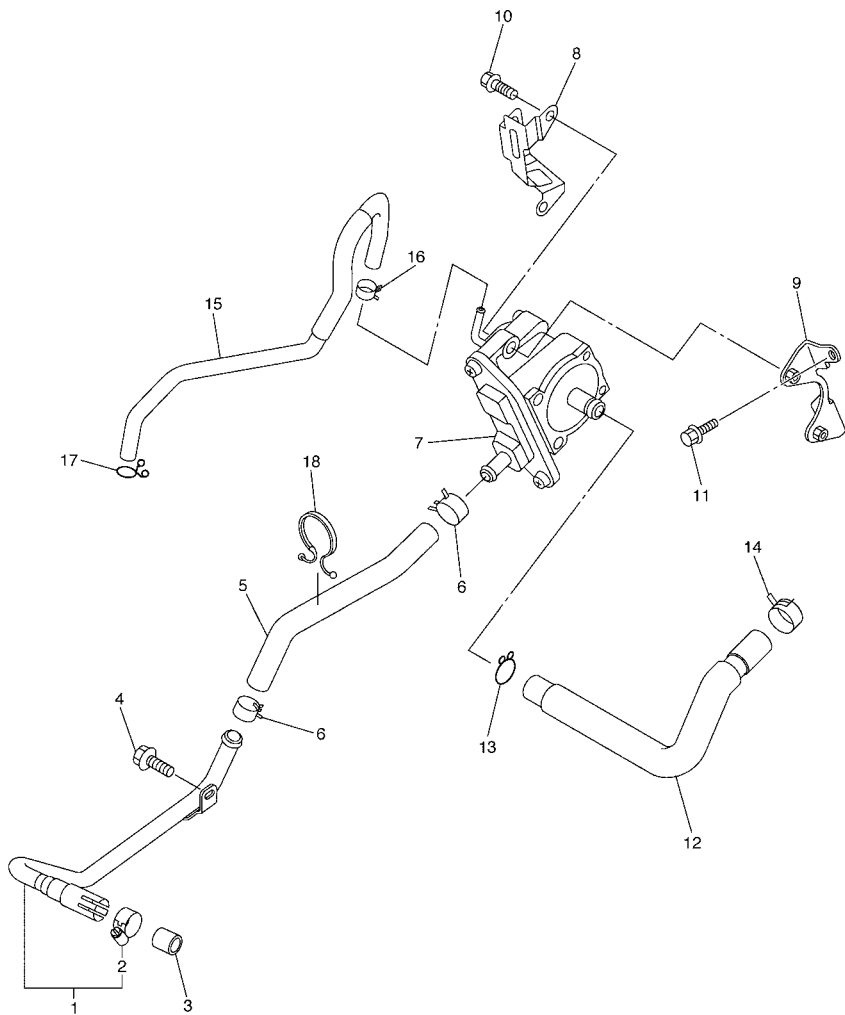


5TJ8100-D100

FIG. 10 CARBURETOR

REF. NO.	PART NO.	DESCRIPTION	5TJ8	5TJ9	5TJA	REMARKS
51	4MX-14115-00	.PLUG, SCREW	1	1	1	
52	3TJ-14137-40	.CLIP	5	5	5	
53	5BE-14146-00	.PLATE	2	2	2	
54	5TA-14261-00	.HOLDER	1	1	1	
55	5TA-14196-00	.PIPE	2	2	2	
56	5TA-14197-00	.PIPE	2	2	2	
57	5TJ-14987-00	.HOSE	1	1	1	
58	5JG-14346-00	.PLATE	1	1	1	
59	5JG-14565-00	.SCREW	1	1	1	
60	5JG-14531-00	.SPRING, ADJUST SCREW	1	1	1	
61	5TJ-14591-10	.SCREW	1	1	1	
62	5PA-14146-00	.PLATE	1	1	1	
63	5GS-14940-00	.DIAPHRAGM ASSY	1	1	1	
64	5GS-14958-00	.COVER, DIAPHRAGM	1	1	1	
65	5GS-14933-00	.SPRING, DIAPHRAGM	1	1	1	
66	97602-04110	.SCREW, PAN HEAD WITH WASHER	2	2	2	

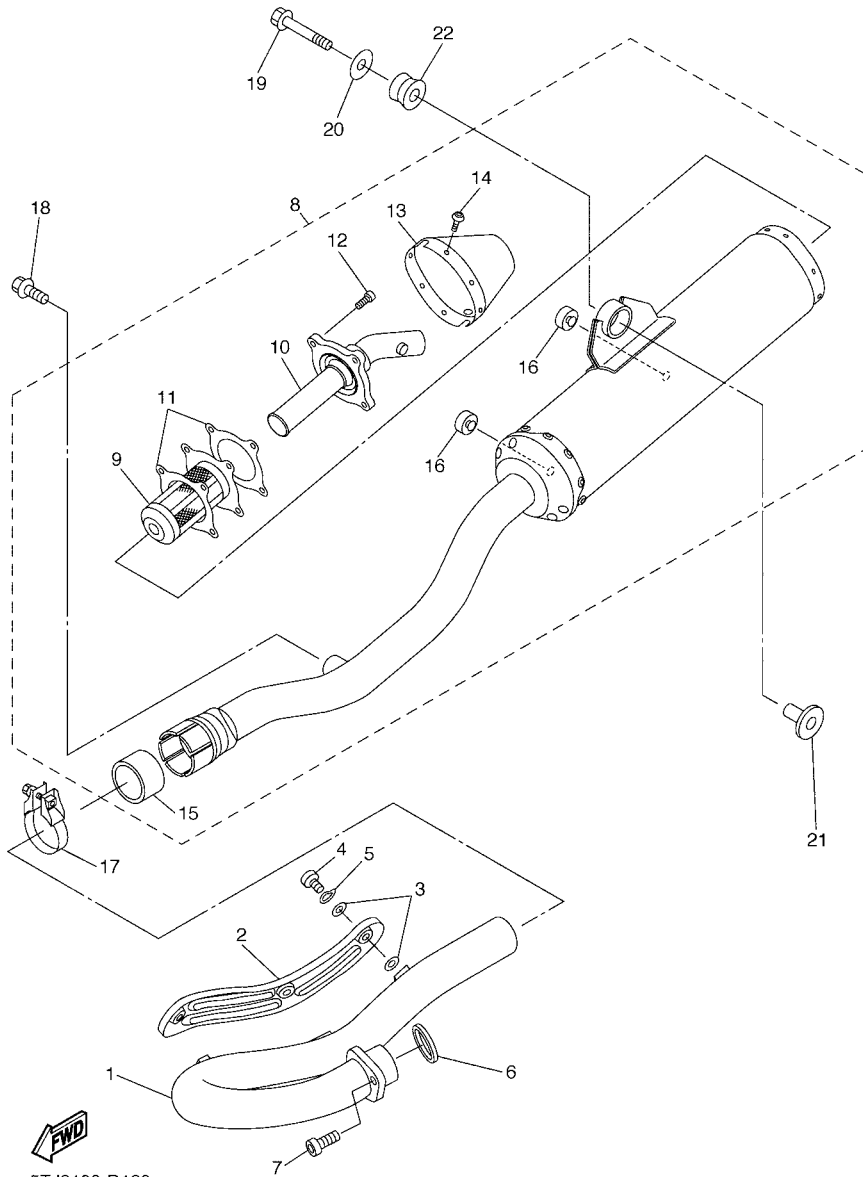
**FIG. 11 AIR INDUCTION SYSTEM**



5TJ8100-D110

REF. NO.	PART NO.	DESCRIPTION	5TJ8	5TJ9	5TJA	REMARKS
1	5TJ-14871-00	PIPE 1	1	1	1	
2	90450-20078	.HOSE CLAMP ASSY	1	1	1	
3	4KM-14714-01	GASKET, MUFFLER	1	1	1	
4	95027-06012	BOLT, FLANGE	1	1	1	
5	5TJ-14881-00	HOSE, BEND 1	1	1	1	
6	90467-15054	CLIP	2	2	2	
7	5TJ-14803-00	AIR INDUCTION SYSTEM ASSY	1	1	1	
8	5TJ-1482K-00	PLATE	1	1	1	
9	5TJ-14834-00	STAY	1	1	1	
10	95027-06020	BOLT, FLANGE	2	2	2	
11	95027-06010	BOLT, FLANGE	2	2	2	
12	5TJ-14882-00	HOSE, BEND 2	1	1	1	
13	90467-15197	CLIP	1	1	1	
14	90468-08104	CLIP	1	1	1	
15	5TJ-13542-00	HOSE, VACUUM SENSING 1	1	1	1	
16	90467-07138	CLIP	1	1	1	
17	90467-09006	CLIP	1	1	1	
18	90464-23041	CLAMP	1	1	1	

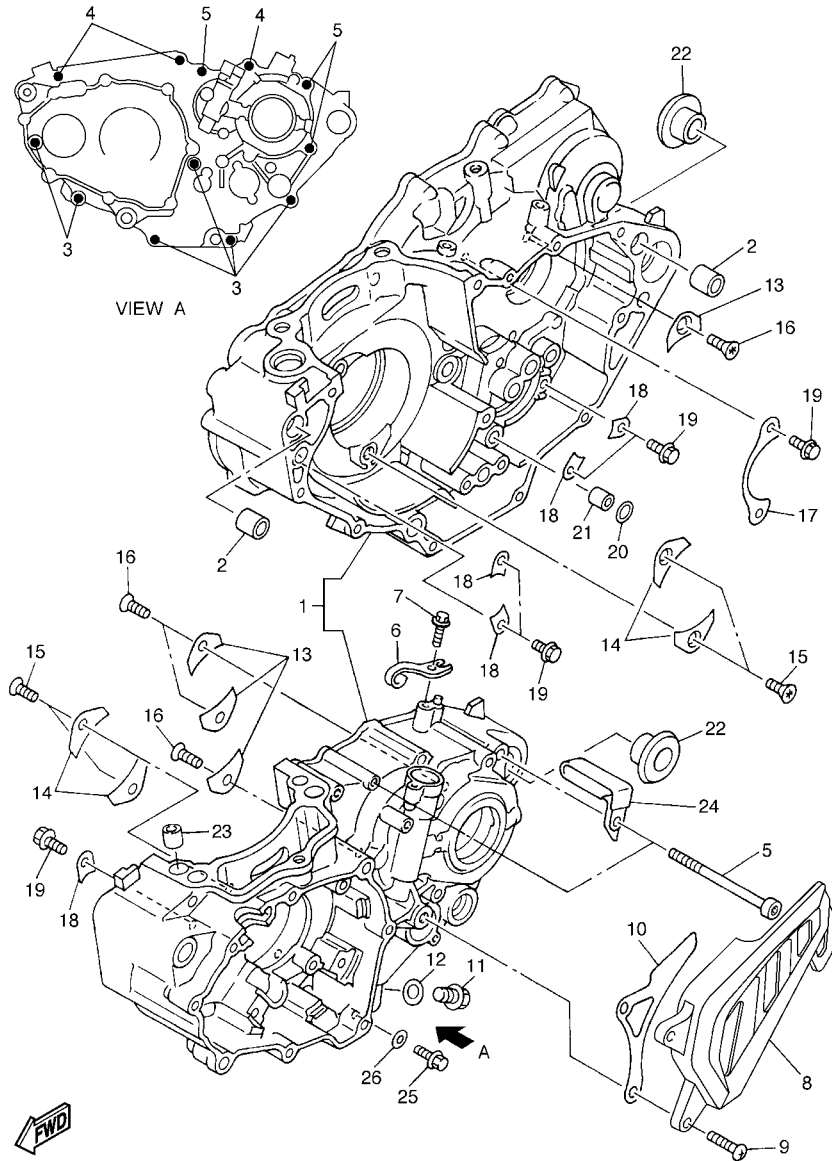




5TJ8100-D120

FIG. 12 EXHAUST

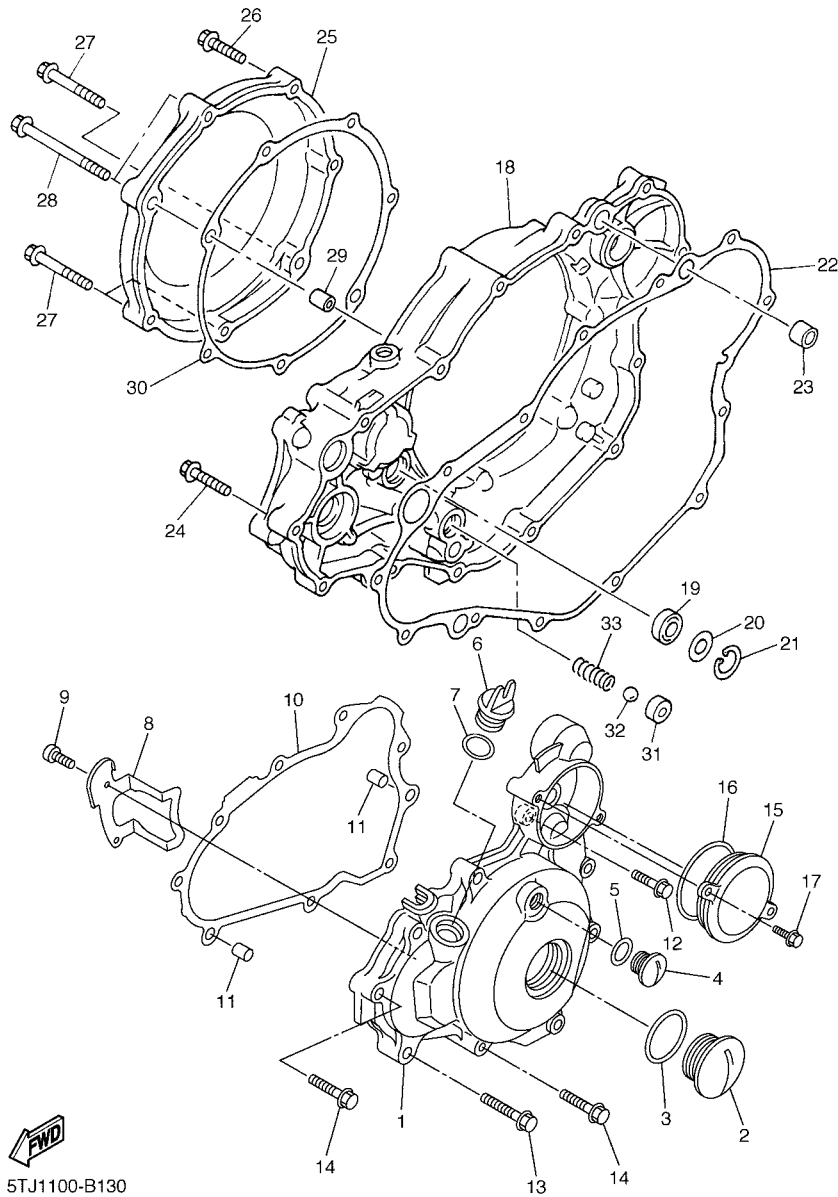
REF. NO.	PART NO.	DESCRIPTION	5TJ8	5TJ9	5TJA	REMARKS
1	5TJ-14611-00	PIPE, EXHAUST 1	1	1	1	
2	5TA-14628-00	PROTECTOR, EXHAUST PIPE	1	1	1	
3	4BD-14766-00	WASHER, PROTECTOR	6	6	6	
4	98980-06008	SCREW, BIND	3	3	3	
5	90206-06090	WASHER, WAVE	3	3	3	
6	3VD-14613-01	GASKET, EXHAUST PIPE	1	1	1	
7	91317-08020	BOLT	1	1	1	
8	5TJ-14710-80	MUFFLER ASSY 1	1	1	1	
9	5TJ-14780-00	.SPARK ARRESTER ASSY	1	1	1	
10	5TJ-14784-00	.PIPE, TAIL	1	1	1	
11	5TJ-14623-00	.GASKET, EXHAUST PIPE	2	2	2	
12	91314-05008	.BOLT	4	4	4	
13	5TJ-14799-00	.CAP	1	1	1	
14	92014-05008	.BOLT, BUTTON HEAD	6	6	6	
15	5XD-14714-00	.GASKET, MUFFLER	1	1	1	
16	22W-24181-00	.DAMPER, LOCATING 1	2	2	2	
17	5BE-14788-00	BAND, SILENCER	1	1	1	
18	90105-08057	BOLT, FLANGE	1	1	1	
19	90105-08659	BOLT, FLANGE	1	1	1	
20	90201-08008	WASHER, PLATE	1	1	1	
21	90387-0814J	COLLAR	1	1	1	
22	5BE-14747-00	DAMPER, MUFFLER	1	1	1	



5TJ5100-C120

FIG. 13 CRANKCASE

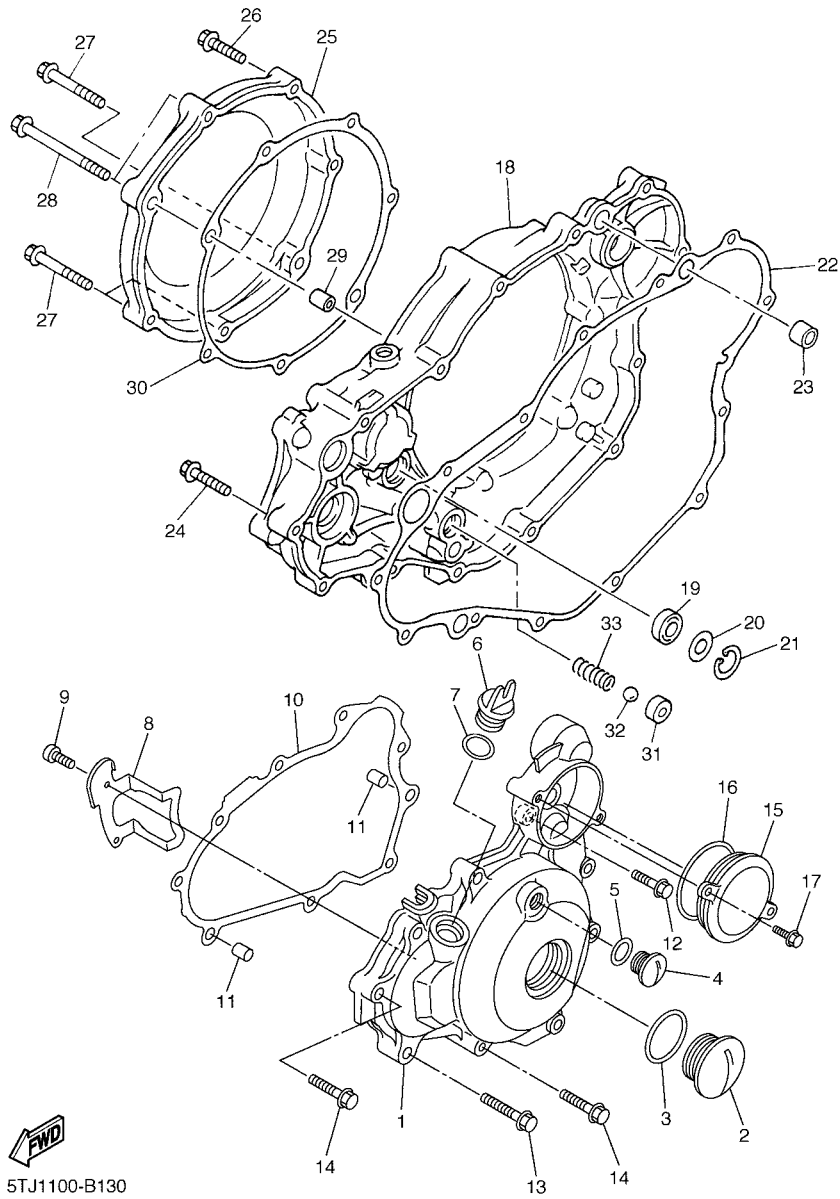
REF. NO.	PART NO.	DESCRIPTION	5TJ8	5TJ9	5TJA	REMARKS
1	5TJ-15150-10	CRANKCASE ASSY	1	1	1	
2	99530-14016	PIN, DOWEL	2	2	2	
3	91317-06050	BOLT	6	6	6	
4	91317-06060	BOLT	3	3	3	
5	91317-06075	BOLT	3	3	3	
6	5TA-15441-01	HOLDER, CLUTCH CABLE	1	1	1	
7	95027-06016	BOLT, FLANGE	1	1	1	
8	5TA-15421-00	COVER, CRANKCASE 2	1	1	1	
9	98507-06025	SCREW, PAN HEAD	2	2	2	
10	5TA-17466-00	GUIDE, CHAIN	1	1	1	
11	95027-10016	BOLT, FLANGE	1	1	1	
12	90430-10188	GASKET	1	1	1	
13	4JT-15381-01	PLATE, BEARING COVER	4	4	4	
14	5BE-15383-01	PLATE, BEARING COVER	4	4	4	
15	90149-06126	SCREW	4	4	4	
16	90149-06326	SCREW	4	4	4	
17	4L0-17471-00	PLATE, COVER	1	1	1	
18	5DH-18562-00	PLATE, STOPPER 2	5	5	5	
19	90105-06553	BOLT, FLANGE	7	7	7	
20	93210-10197	O-RING	1	1	1	
21	99530-10114	PIN, DOWEL	1	1	1	
22	90387-18007	COLLAR	2	2	2	
23	99530-10116	PIN, DOWEL	2	2	2	
24	90461-10136	CLAMP	1	1	1	
25	95024-06010	BOLT, FLANGE	1	1	1	
26	90430-06014	GASKET	1	1	1	



5TJ1100-B130

FIG. 14 CRANKCASE COVER 1

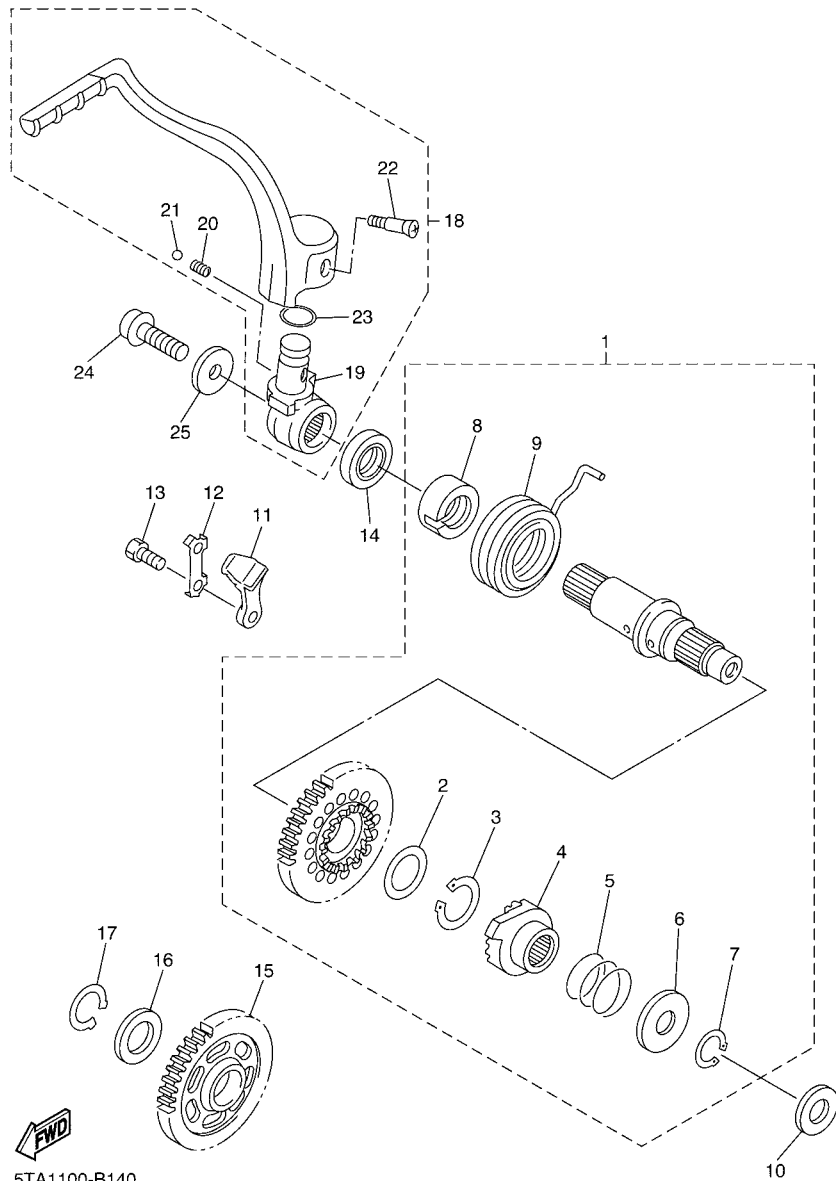
REF. NO.	PART NO.	DESCRIPTION	5TJ8	5TJ9	5TJA	REMARKS
1	5TJ-15411-10	COVER, CRANKCASE 1	1	1	1	
2	90340-27002	PLUG, STRAIGHT SCREW	1	1	1	
3	93210-27370	O-RING	1	1	1	
4	90340-14128	PLUG, STRAIGHT SCREW	1	1	1	
5	93210-14369	O-RING	1	1	1	
6	3Y1-15363-00	PLUG, OIL	1	1	1	
7	93210-19123	O-RING	1	1	1	
8	90465-10017	CLAMP	1	1	1	
9	91317-05012	BOLT	2	2	2	
10	5TJ-15451-00	GASKET, CRANKCASE COVER 1	1	1	1	
11	99530-08016	PIN, DOWEL	2	2	2	
12	95027-06020	BOLT, FLANGE	1	1	1	
13	95027-06040	BOLT, FLANGE	2	2	2	
14	95027-06030	BOLT, FLANGE	6	6	6	
15	5TJ-1549B-10	COVER ASSY 2	1	1	1	
16	93210-58346	O-RING	1	1	1	
17	95027-06016	BOLT, FLANGE	2	2	2	
18	5XD-15431-00	COVER, CRANKCASE 3	1	1	1	
19	93101-14164	OIL SEAL	1	1	1	
20	90201-15701	WASHER, PLATE (T=1.0)	1	1	1	
21	99009-22500	CIRCLIP	1	1	1	
22	5TA-15462-00	GASKET, CRANKCASE COVER 3	1	1	1	
23	91812-16001	PIN, DOWEL	2	2	2	
24	95027-06030	BOLT, FLANGE	10	10	10	
25	5TA-15415-10	COVER, GENERATOR	1	1	1	
26	95027-06030	BOLT, FLANGE	2	2	2	
27	95027-06040	BOLT, FLANGE	3	3	3	



5TJ1100-B130

FIG. 14 CRANKCASE COVER 1

REF. NO.	PART NO.	DESCRIPTION	5TJ8	5TJ9	5TJA	REMARKS
28	95027-06080	BOLT, FLANGE	2	2	2	
29	99530-08016	PIN, DOWEL	2	2	2	
30	5TA-15453-00	GASKET	1	1	1	
31	583-13113-00	SEAT, CHECK BALL	1	1	1	
32	93503-08007	BALL	1	1	1	
33	90501-043E0	SPRING, COMPRESSION	1	1	1	
-----						
-----						
-----						
-----						
-----						
-----						
-----						
-----						
-----						
-----						

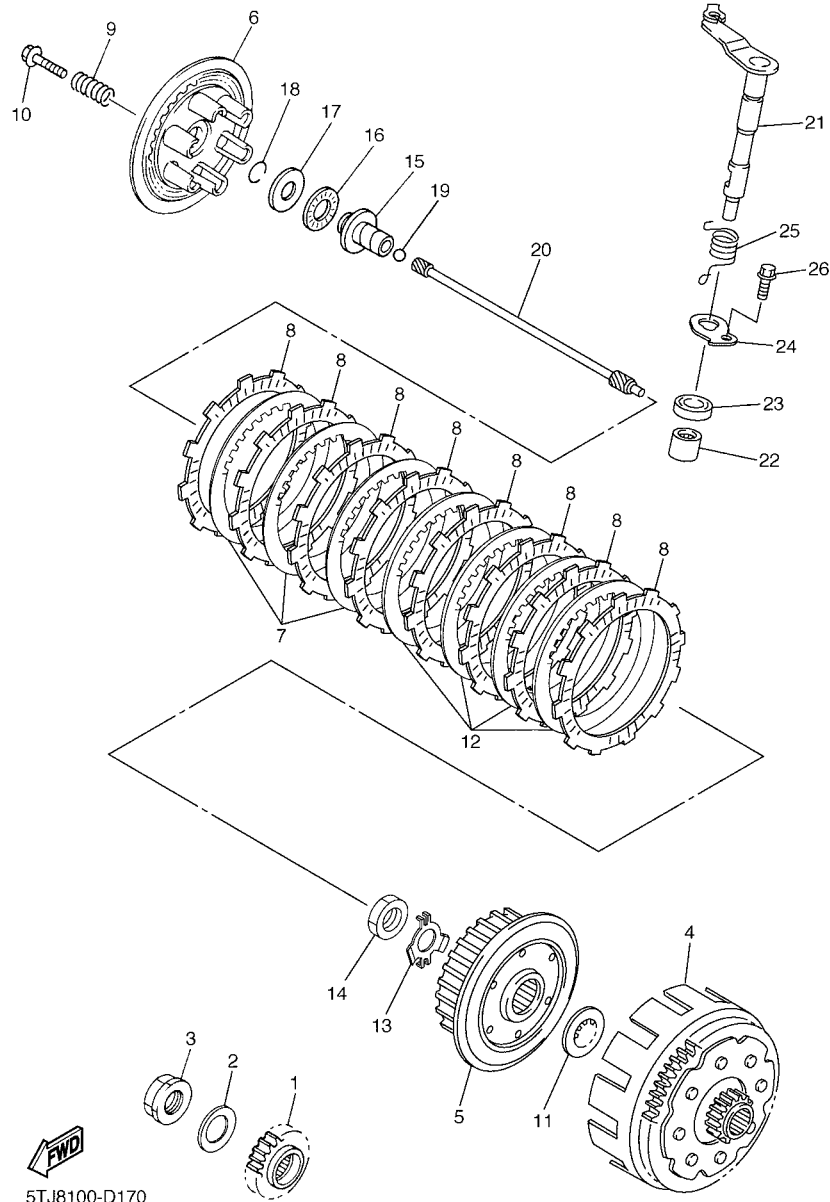


5TA1100-B140

FIG. 15 STARTER

REF. NO.	PART NO.	DESCRIPTION	5TJ8	5TJ9	5TJA	REMARKS
1	5XD-15601-00	KICK SHAFT ASSY	1	1	1	
2	90201-20685	.WASHER, PLATE (T=0.5)	1	1	1	
3	93410-20038	.CIRCLIP	1	1	1	
4	4GY-15671-00	.WHEEL, RATCHET	1	1	1	
5	90501-16016	.SPRING, COMPRESSION	1	1	1	
6	90201-167P7	.WASHER, PLATE	1	1	1	
7	99009-16400	.CIRCLIP	1	1	1	
8	5GR-15664-00	.GUIDE, SPRING	1	1	1	
9	90508-305B0	.SPRING, TORSION	1	1	1	
10	90201-162H4	WASHER, PLATE	1	1	1	
11	5SG-15668-00	STOPPER	1	1	1	
12	214-15686-00	WASHER, LOCK	1	1	1	
13	90101-06001	BOLT	2	2	2	
14	93102-20108	OIL SEAL	1	1	1	
15	5TA-15651-00	GEAR, KICK IDLE	1	1	1	
16	90201-20276	WASHER, PLATE (T=1.0)	1	1	1	
17	99009-20400	CIRCLIP	1	1	1	
18	5XD-15620-00	KICK CRANK ASSY	1	1	1	
19	5XD-15621-00	.BOSS, KICK CRANK	1	1	1	
20	90501-147A5	.SPRING, COMPRESSION	1	1	1	
21	93507-32009	.BALL	1	1	1	
22	90152-06010	.SCREW, COUNTERSUNK	1	1	1	
23	93210-17570	.O-RING	1	1	1	
24	90110-08035	BOLT, HEXAGON SOCKET HEAD	1	1	1	
25	90201-087A9	WASHER, PLATE	1	1	1	

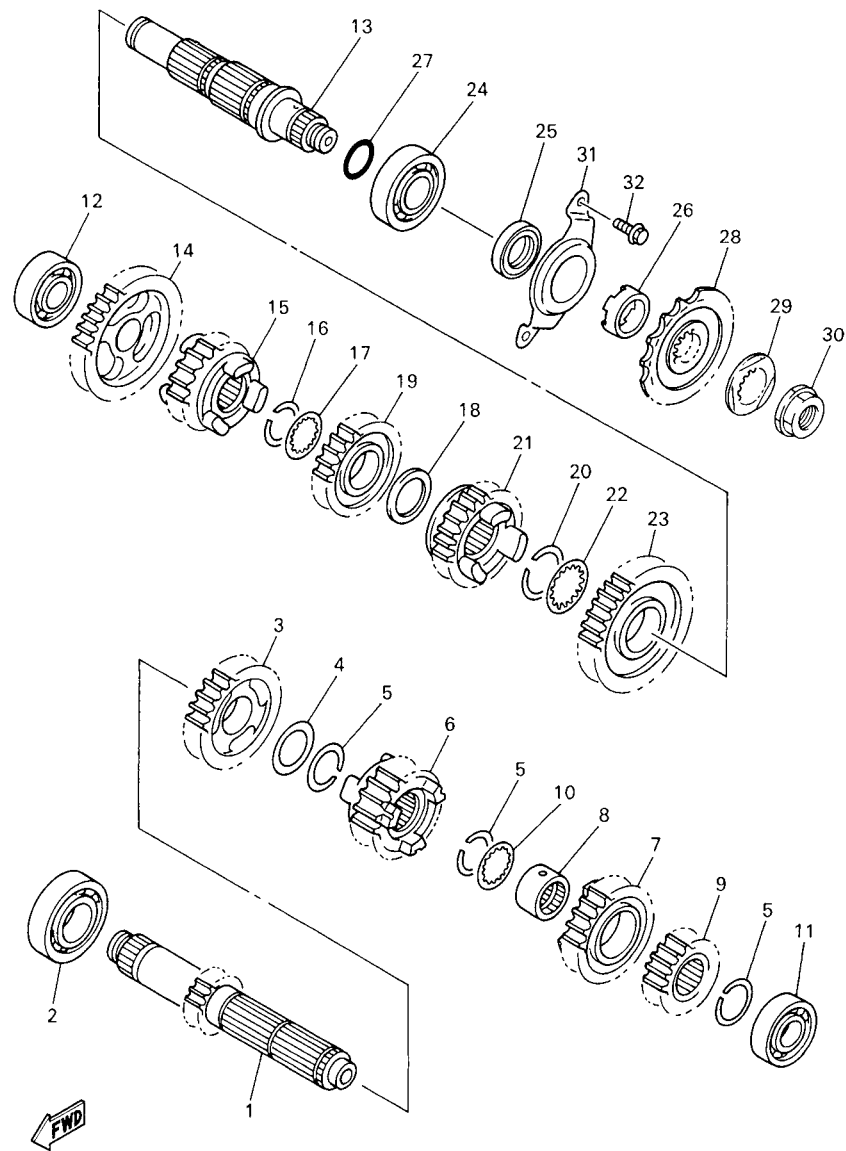




5TJ8100-D170

FIG. 17 CLUTCH

REF. NO.	PART NO.	DESCRIPTION	5TJ8	5TJ9	5TJA	REMARKS
1	5TJ-16111-00	GEAR, PRIMARY DRIVE	1	1	1	
2	90208-25045	WASHER, CONICAL SPRING	1	1	1	
3	90179-20009	NUT	1	1	1	
4	5XD-16150-20	PRIMARY DRIVEN GEAR COMP.	1	1	1	
5	5TA-16371-10	BOSS, CLUTCH	1	1	1	
6	5JG-16351-00	PLATE, P <small>RE</small> SSURE 1	1	1	1	
7	4X7-16325-00	PLATE, CLUTCH 2	3	3	3	
8	5TA-16321-00	PLATE, FRICTION	8	8	8	
9	90501-237L0	SPRING, COMPRESSION	6	6	6	
10	90159-06092	SCREW, WITH WASHER	6	6	6	
11	5XD-16154-00	PLATE, THRUST 1	1	1	1	
12	1TA-16325-00	PLATE, CLUTCH 2	4	4	4	
13	90215-20005	WASHER, LOCK	1	1	1	
14	90170-20327	NUT	1	1	1	
15	5JG-16356-00	ROD, PUSH 1	1	1	1	
16	93340-21505	BEARING	1	1	1	
17	90201-125L6	WASHER, PLATE	1	1	1	
18	93440-10085	CIRCLIP	1	1	1	
19	93511-32027	BALL	1	1	1	
20	5TA-16357-10	ROD, PUSH 2	1	1	1	
21	5TJ-16381-10	PUSH LEVER COMP.	1	1	1	
22	93317-11287	BEARING	1	1	1	
23	93102-12224	OIL SEAL	1	1	1	
24	5TA-16384-01	PLATE, SEAT	1	1	1	
25	90508-14020	SPRING, TORSION	1	1	1	
26	95027-06012	BOLT, FLANGE	1	1	1	



5GS5100-0160

FIG. 18 TRANSMISSION

REF. NO.	PART NO.	DESCRIPTION	5TJ8	5TJ9	5TJA	REMARKS
1	5TJ-17411-10	AXLE, MAIN (12T)	1	1	1	
2	93306-20532	BEARING	1	1	1	
3	5TJ-17151-00	GEAR, 5TH PINION (25T)	1	1	1	
4	90201-253K0	WASHER, PLATE (T=1.0)	1	1	1	
5	93440-25084	CIRCLIP	3	3	3	
6	5TJ-17131-00	GEAR, 3RD PINION (16T)	1	1	1	
7	5TJ-17141-10	GEAR, 4TH PINION (20T)	1	1	1	
8	90387-2113G	COLLAR	1	1	1	
9	5BF-17121-00	GEAR, 2ND PINION (15T)	1	1	1	
10	90209-21332	WASHER	1	1	1	
11	93306-00431	BEARING	1	1	1	
12	93306-00426	BEARING	1	1	1	
13	5BE-17402-00	DRIVE AXLE ASSY	1	1	1	
14	5BF-17211-00	GEAR, 1ST WHEEL (29T)	1	1	1	
15	5BF-17251-00	GEAR, 5TH WHEEL (21T)	1	1	1	
16	93440-25084	CIRCLIP	1	1	1	
17	90209-21332	WASHER	1	1	1	
18	90201-253K0	WASHER, PLATE (T=1.0)	1	1	1	
19	5TJ-17231-10	GEAR, 3RD WHEEL (21T)	1	1	1	
20	93440-28062	CIRCLIP	1	1	1	
21	5TJ-17241-10	GEAR, 4TH WHEEL (21T)	1	1	1	
22	90209-26348	WASHER	1	1	1	
23	5TJ-17221-00	GEAR, 2ND WHEEL (26T)	1	1	1	
24	93306-20593	BEARING	1	1	1	
25	93102-32480	OIL SEAL	1	1	1	
26	90387-2513F	COLLAR	1	1	1	
27	93210-22164	O-RING	1	1	1	







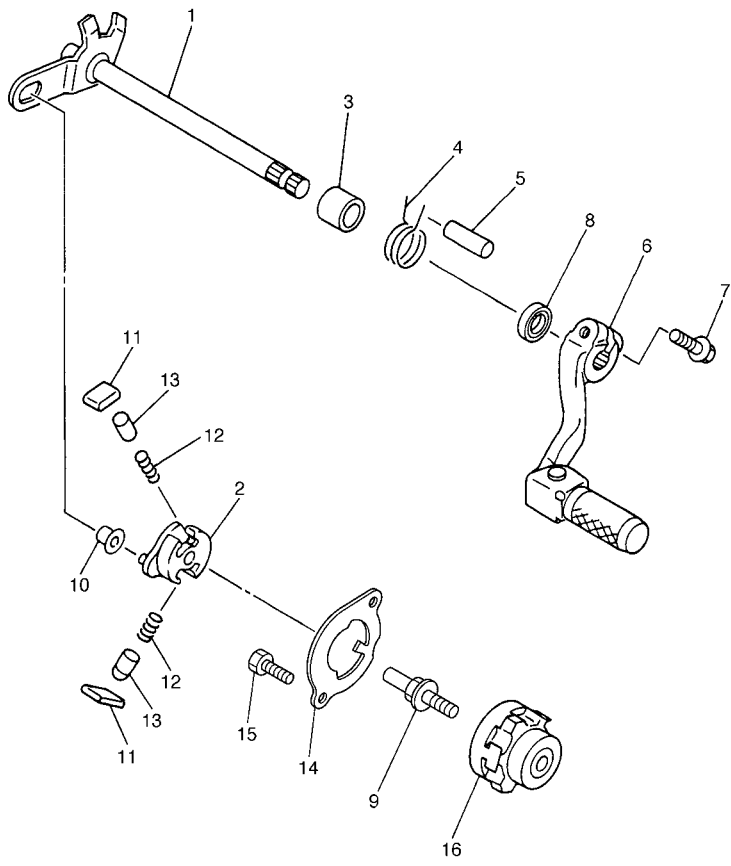


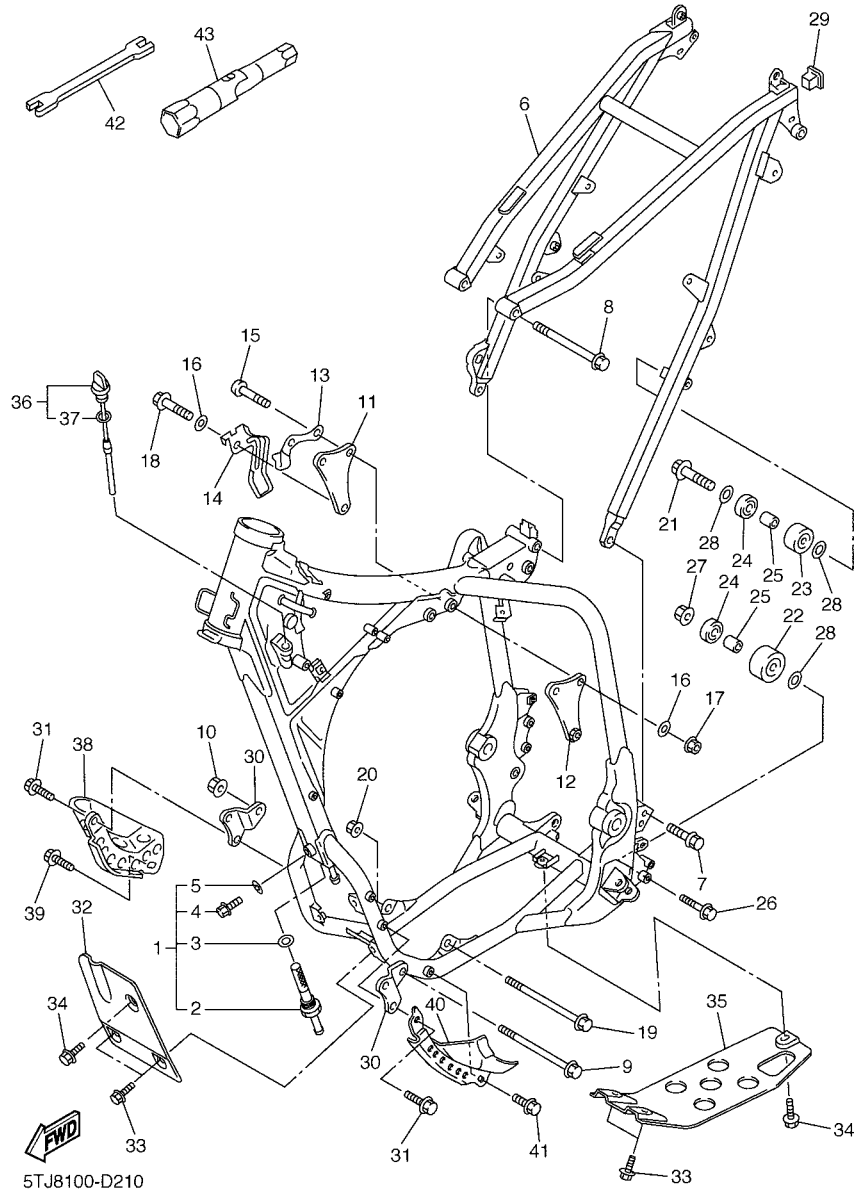
FIG. 20 SHIFT SHAFT

REF. NO.	PART NO.	DESCRIPTION	5TJ8	5TJ9	5TJA	REMARKS
1	5TJ-18101-00	SHIFT SHAFT ASSY	1	1	1	
2	5MW-18122-01	LEVER, SHIFT 2	1	1	1	
3	90387-124F4	COLLAR	1	1	1	
4	90508-291A8	SPRING, TORSION	1	1	1	
5	93608-33002	PIN, DOWEL	1	1	1	
6	5UL-18110-00	SHIFT PEDAL ASSY	1	1	1	
7	95027-06020	BOLT, FLANGE	1	1	1	
8	93102-12224	OIL SEAL	1	1	1	
9	3XJ-18173-10	PIN, SHIFT	1	1	1	
10	3XJ-18178-00	ROLLER, SHIFT LEVER	1	1	1	
11	3XJ-18182-00	PAWL, SHIFTER	2	2	2	
12	90501-052G5	SPRING, COMPRESSION	2	2	2	
13	3XJ-18184-00	PIN, PAWL	2	2	2	
14	5TJ-18172-00	GUIDE, SHIFT	1	1	1	
15	90101-06034	BOLT	2	2	2	
16	4EW-18185-00	SEGMENT	1	1	1	



5TJ5100-C190

**C15**



5TJ8100-D210

FIG. 21 FRAME

REF. NO.	PART NO.	DESCRIPTION	5TJ8	5TJ9	5TJA	REMARKS
1	5TJ-21101-80	FRONT FRAME COMP.	1	1	1	
2	5TA-21756-00	.NET, FILTER	1	1	1	
3	90201-145M4	.WASHER, PLATE	1	1	1	
4	95827-08012	.BOLT, FLANGE	1	1	1	
5	90430-08119	.GASKET	1	1	1	
6	5TJ-21190-80	REAR FRAME COMP.	1	1	1	
7	90105-08057	BOLT, FLANGE	2	2	2	
8	90105-08120	BOLT, FLANGE	1	1	1	
9	90105-10099	BOLT, FLANGE	1	1	1	
10	90179-10658	NUT	1	1	1	
11	5XD-21425-00	BRACKET, REAR UPPER 1	1	1	1	
12	5XD-21425-10	BRACKET, REAR UPPER 1	1	1	1	
13	5TA-21161-00	HOLDER, CABLE	1	1	1	
14	5TJ-21335-00	CLAMP, WIRE HARNESS 1	1	1	1	
15	92017-10060	BOLT, BUTTON HEAD	2	2	2	
16	90201-104R2	WASHER, PLATE	3	3	3	
17	90179-10658	NUT	2	2	2	
18	95817-10055	BOLT, FLANGE	1	1	1	
19	90105-10733	BOLT, FLANGE	1	1	1	
20	90179-10658	NUT	1	1	1	
21	95027-08040	BOLT, FLANGE	1	1	1	
22	3JD-22178-20	TENSIONER	1	1	1	
23	4EW-22178-01	TENSIONER	1	1	1	
24	93300-60804	BEARING	2	2	2	
25	90387-086N4	COLLAR	2	2	2	
26	95027-08065	BOLT, FLANGE	1	1	1	
27	95707-08500	NUT, FLANGE	1	1	1	

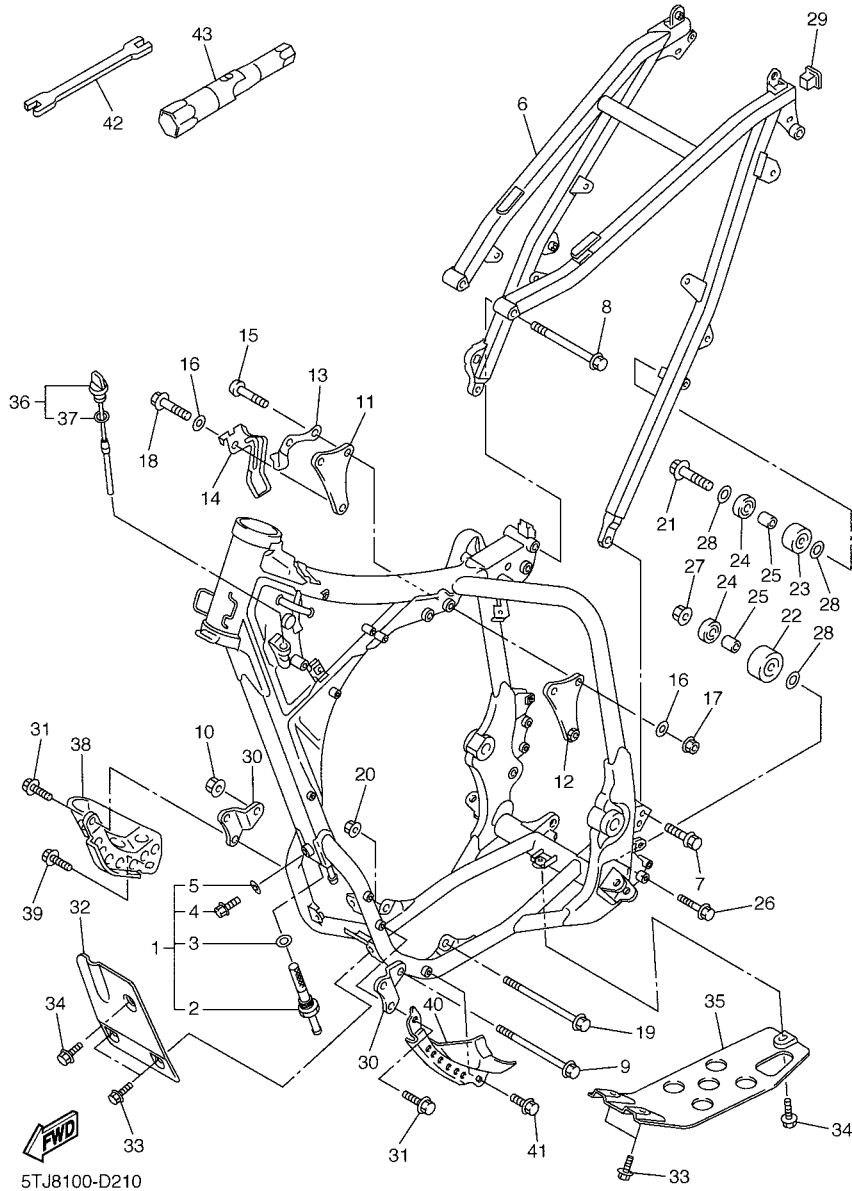
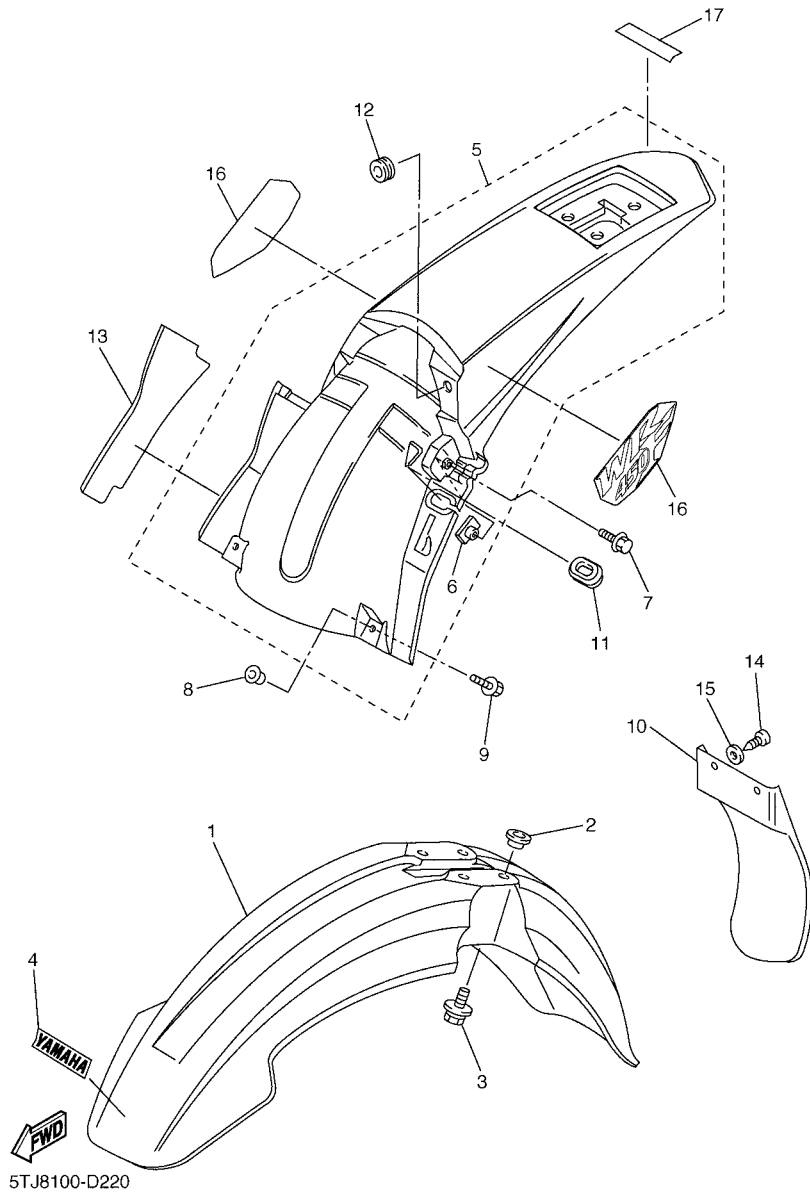


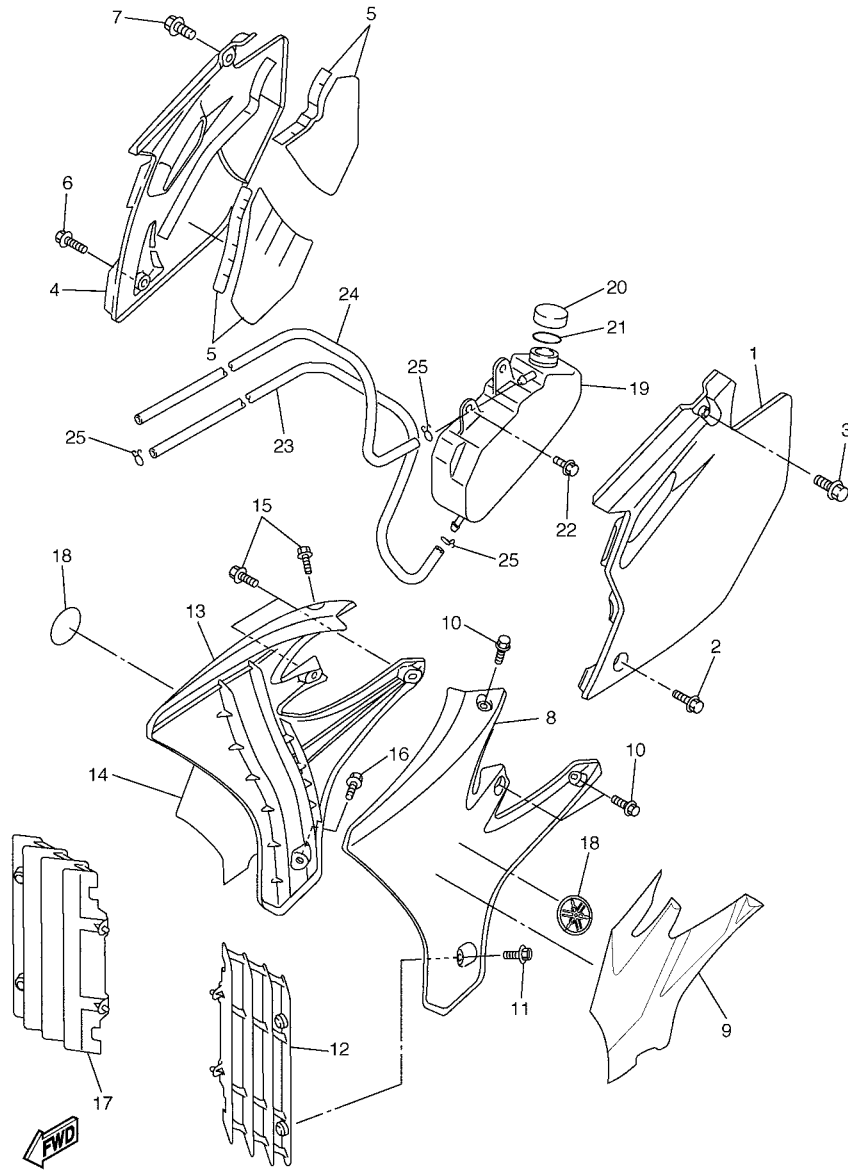
FIG. 21 FRAME

REF. NO.	PART NO.	DESCRIPTION	5TJ8	5TJ9	5TJA	REMARKS
28	90201-086P8	WASHER, PLATE	3	3	3	
29	90338-18176	PLUG	1	1	1	
30	5XD-21417-50	BRACKET, FRONT LOWER 1	2	2	2	
31	95817-08016	BOLT, FLANGE	4	4	4	
32	5TA-21471-00	PROTECTOR, ENGINE	1	1	1	
33	95027-06012	BOLT, FLANGE	4	4	4	
34	90119-06001	BOLT, WITH WASHER	2	2	2	
35	5TA-2147E-00	GUARD, ENGINE 2	1	1	1	
36	5TA-15362-01	PLUG, OIL LEVEL	1	1	1	
37	93210-08001	.O-RING	1	1	1	
38	5TA-2147A-00	GUARD, ENGINE 1	1	1	1	
39	95027-08012	BOLT, FLANGE	1	1	1	
40	5TJ-2147F-00	GUARD, ENGINE 3	1	1	1	
41	95027-08012	BOLT, FLANGE	1	1	1	
42	5ET-28166-00	WRENCH, HEXAGON	1	1	1	
43	5TA-2814F-00	BOX, SPARK PLUG	1	1	1	

FIG. 22 FENDER



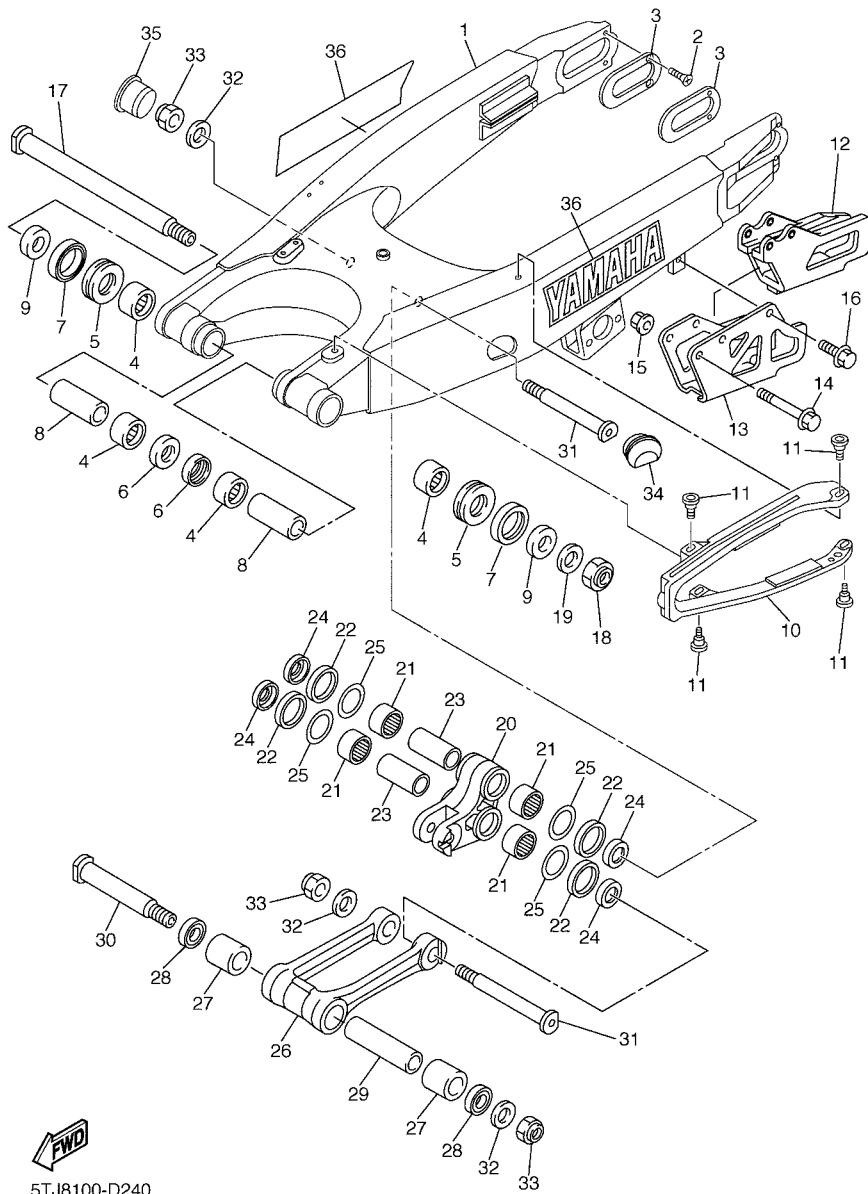
REF. NO.	PART NO.	DESCRIPTION	5TJ8	5TJ9	5TJA	REMARKS
1	5HD-21511-00	FENDER, FRONT	1	1	1	
2	90387-06090	COLLAR	4	4	4	
3	90119-06096	BOLT, WITH WASHER	4	4	4	
4	4ES-2153E-01	EMBLEM, YAMAHA	1	1	1	
5	5TJ-21610-80	REAR FENDER COMP.	1	1	1	
6	5XD-21635-00	.NUT, REAR FENDER	2	2	2	
7	90119-06192	BOLT, WITH WASHER	2	2	2	
8	90387-06009	COLLAR	2	2	2	
9	90119-06225	BOLT, WITH WASHER	2	2	2	
10	5TA-21642-00	GUARD, FLAP	1	1	1	
11	90480-01512	GROMMET	1	1	1	
12	90480-14532	GROMMET	1	1	1	
13	5TA-2174T-00	INSULATOR, SIDE COVER 2	1	1	1	
14	97707-60016	SCREW, TAPPING	2	2	2	
15	90201-06557	WASHER, PLATE	2	2	2	
16	5TJ-2163G-10	EMBLEM 1	2	2	2	
17	4ES-2153E-01	EMBLEM, YAMAHA	1	1	1	



5TJ8100-D230

FIG. 23 SIDE COVER

REF. NO.	PART NO.	DESCRIPTION	5TJ8	5TJ9	5TJA	REMARKS
1	5TJ-21711-80	COVER, SIDE 1	1	1	1	
2	95827-06016	BOLT, FLANGE	1	1	1	
3	90119-08238	BOLT, WITH WASHER	1	1	1	
4	5TJ-21721-00	COVER, SIDE 2	1	1	1	
5	5TJ-2174A-00	INSULATOR, SIDE COVER	1	1	1	
6	95827-06016	BOLT, FLANGE	1	1	1	
7	90119-08238	BOLT, WITH WASHER	1	1	1	
8	5TA-21730-00	SIDE COVER ASSY 3	1	1	1	
9	5XD-2173E-10	GRAPHIC 1	1	1	1	
10	90105-06055	BOLT, FLANGE	3	3	3	
11	90159-06078	SCREW, WITH WASHER	1	1	1	
12	5TA-2172A-00	PANEL 1	1	1	1	
13	5TA-21740-00	SIDE COVER ASSY 4	1	1	1	
14	5XD-2173F-10	GRAPHIC 2	1	1	1	
15	90105-06055	BOLT, FLANGE	3	3	3	
16	90159-06078	SCREW, WITH WASHER	1	1	1	
17	5TA-2172A-00	PANEL 1	1	1	1	
18	5MV-2175C-00	TUNING FORK MARK	2	2	2	
19	5GS-21871-00	TANK, RECOVERY	1	1	1	
20	26H-21875-00	CAP	1	1	1	
21	26H-21874-00	GASKET	1	1	1	
22	90119-06051	BOLT, WITH WASHER	2	2	2	
23	91A20-05140	TUBE, FLEXIBLE VINYL	1	1	1	
24	91A11-05125	TUBE, FLEXIBLE	1	1	1	
25	90467-09006	CLIP	3	3	3	



5TJ8100-D240

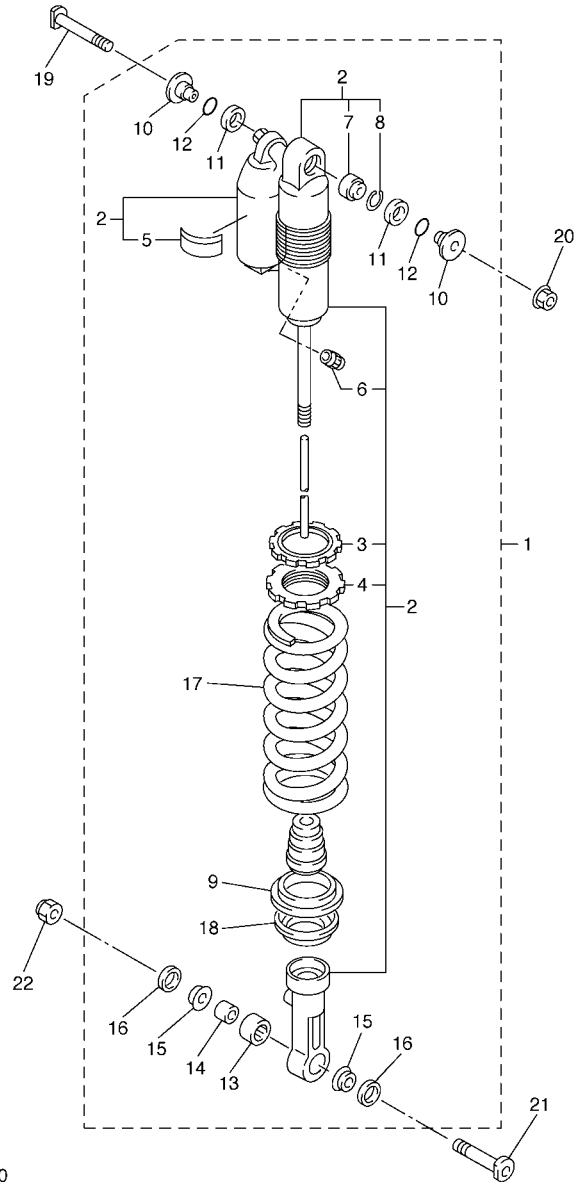
FIG. 24 REAR ARM

REF. NO.	PART NO.	DESCRIPTION	5TJ8	5TJ9	5TJA	REMARKS
1	1C3-22110-00	REAR ARM COMP.	1	1	1	
2	90151-04001	SCREW, COUNTERSUNK	4	4	4	
3	1P8-22355-00	PATCH	2	2	2	
4	93317-22262	BEARING	4	4	4	
5	93342-22217	BEARING	2	2	2	
6	93106-22019	OIL SEAL (DC 22-28-8)	2	2	2	
7	93109-28043	OIL SEAL	2	2	2	
8	90387-18004	COLLAR	2	2	2	
9	90387-18009	COLLAR	2	2	2	
10	1C3-22151-00	SEAL, GUARD	1	1	1	
11	1C3-22969-10	SCREW, 1	4	4	4	
12	5UN-22199-00	SUPPORT, CHAIN	1	1	1	
13	5UN-22128-00	COVER, THRUST 1	1	1	1	
14	95027-06050	BOLT, FLANGE	2	2	2	
15	90179-06568	NUT	2	2	2	
16	95027-06010	BOLT, FLANGE	1	1	1	
17	5XD-22141-50	SHAFT, PIVOT	1	1	1	
18	90185-16127	NUT, SELF-LOCKING	1	1	1	
19	90201-160F6	WASHER, PLATE	1	1	1	
20	1C3-2217A-00	ARM, RELAY	1	1	1	
21	93315-32166	BEARING	4	4	4	
22	93109-25001	OIL SEAL	4	4	4	
23	90387-16010	COLLAR	2	2	2	
24	90209-16008	WASHER	4	4	4	
25	90201-21013	WASHER, PLATE	4	4	4	
26	1C3-2217F-00	ROD, CONNECTING 1	1	1	1	
27	93315-32165	BEARING	2	2	2	



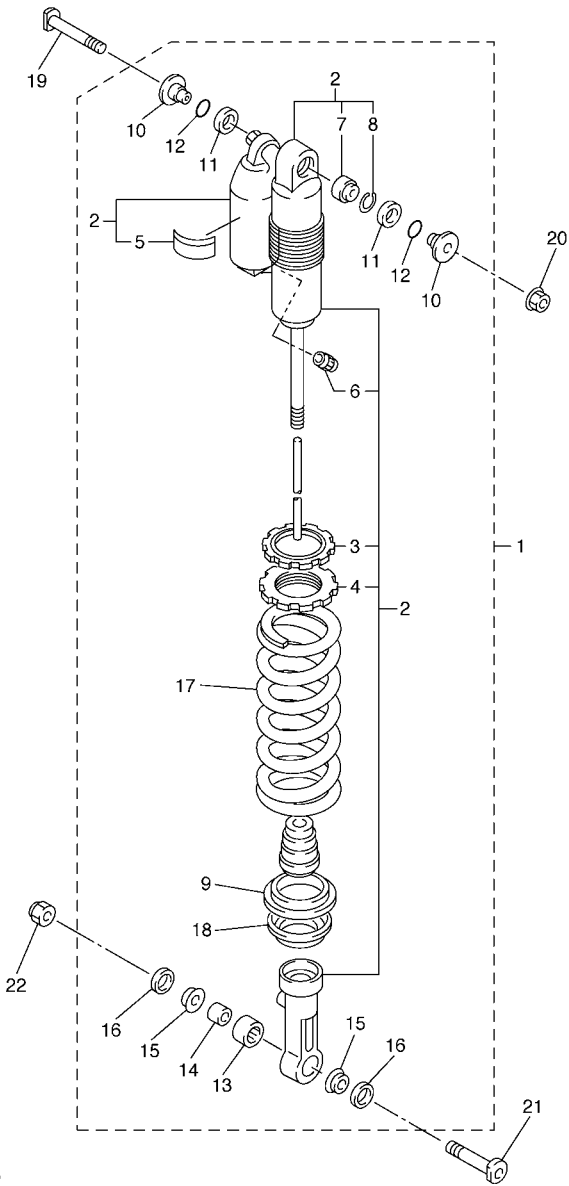


**FIG. 25 REAR SUSPENSION**



**FWD**  
5XD1100-C230

REF. NO.	PART NO.	DESCRIPTION	5TJ8	5TJ9	5TJA	REMARKS
1	5TJ-22210-L0	SHOCK ABSORBER ASSY, REAR	1			
	5TJ-22210-90	SHOCK ABSORBER ASSY, REAR		1		
	5TJ-22210-M0	SHOCK ABSORBER ASSY, REAR			1	UR FOR CAN
	5TJ-22210-A0	SHOCK ABSORBER ASSY, REAR			1	UR FOR OCE,ZAF
2	5TJ-22201-L0	.DAMPER SUB ASSY	1			
	5TJ-22201-90	.DAMPER SUB ASSY		1		
	5TJ-22201-M0	.DAMPER SUB ASSY			1	UR FOR CAN
	5TJ-22201-A0	.DAMPER SUB ASSY			1	UR FOR OCE,ZAF
3	3SP-22234-00	..GUIDE, SPRING 3	1	1	1	
4	3SP-22213-00	..SEAT, SPRING UPPER	1	1	1	
5	4AA-22259-80	..LABEL, WARNING	1			
	4AA-22259-40	..LABEL, WARNING		1	1	UR FOR OCE,ZAF
	4AA-22259-60	..LABEL, WARNING			1	UR FOR CAN
6	509-23184-L0	..CAP, AIR VALVE	1	1	1	
7	4JX-22226-00	..BUSH, SHOCK ABSORBER LOWER	1	1	1	
8	5DH-23183-00	..CIRCLIP	1	1	1	
9	5MV-22224-00	.GUIDE, SPRING 2	1	1	1	
10	1C3-22253-00	.COLLAR, DISTANCE	2	2	2	
11	3JE-22475-00	.SEAL, DUST	2	2	2	
12	4EW-22474-00	.SEAL, RING	2	2	2	
13	5UN-22176-00	.BEARING	1	1	1	
14	5MV-22184-00	.BUSH	1	1	1	
15	5MV-22253-00	.COLLAR, DISTANCE	2	2	2	
16	5NY-22475-00	.SEAL, DUST	2	2	2	
17	5UN-22212-50	.SPRING (K=52N/MM)	1		1	UR FOR CAN
	5UN-22212-30	.SPRING (K=48N/MM)		1		
	5UN-22212-60	.SPRING (K=54N/MM)			1	UR FOR OCE,ZAF



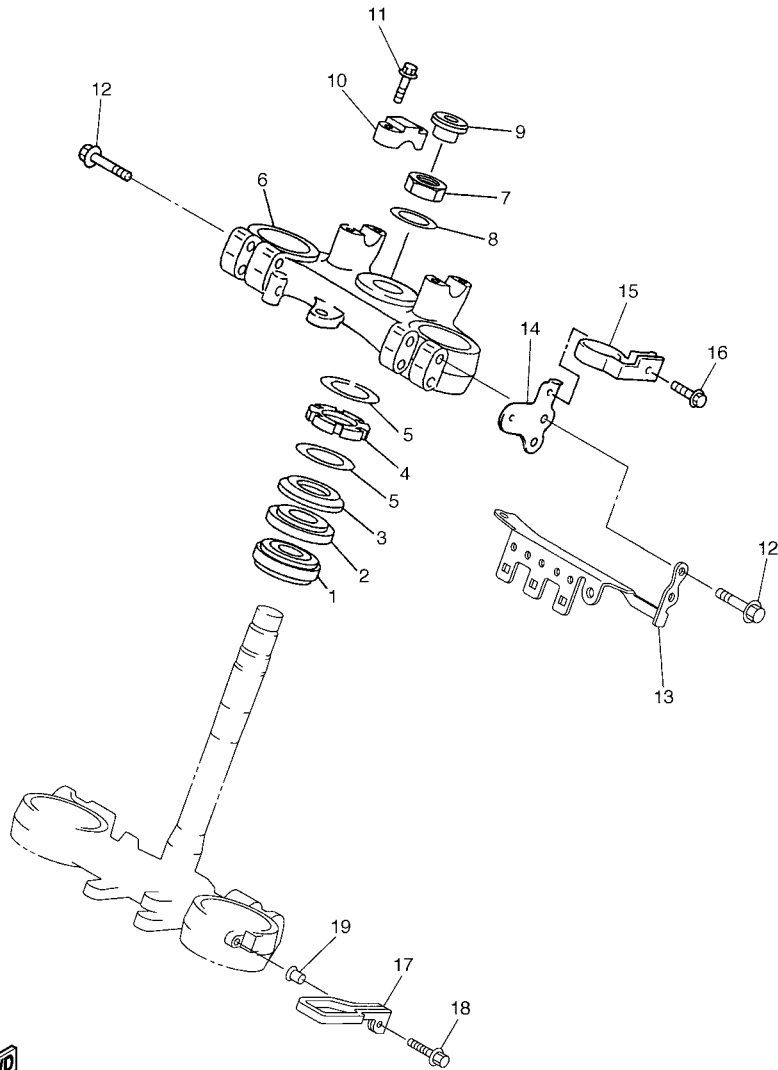
**FWD**  
5XD1100-C230

**FIG. 25 REAR SUSPENSION**

REF. NO.	PART NO.	DESCRIPTION	5TJ8	5TJ9	5TJA	REMARKS
18	5XE-22214-00	.GUIDE, SPRING 1	1	1	1	
19	5XE-22242-00	BOLT 2	1	1	1	
20	95607-10200	NUT, U FLANGE	1	1	1	
21	5NY-22241-00	BOLT 1	1	1	1	
22	90185-10060	NUT, SELF-LOCKING	1	1	1	
-----						
-----						
-----						
-----						
-----						
-----						
-----						
-----						
-----						
-----						

**D9**

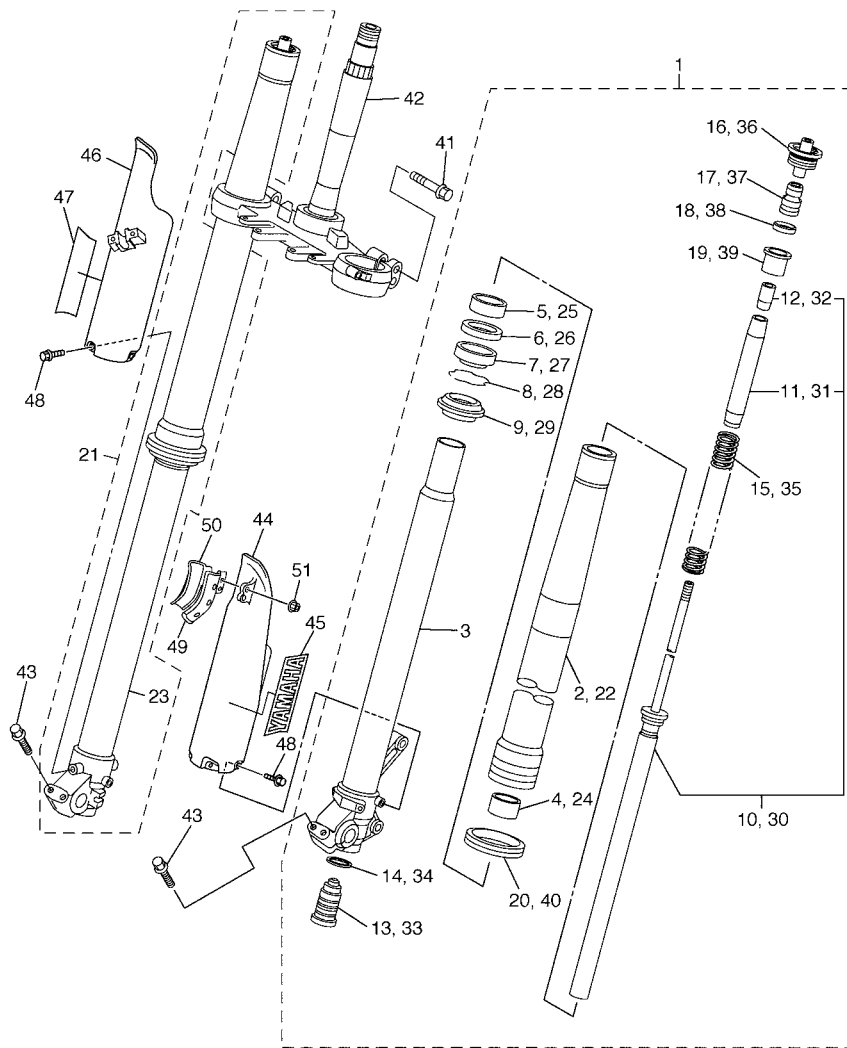
FIG. 26 STEERING



REF. NO.	PART NO.	DESCRIPTION	5TJ8	5TJ9	5TJA	REMARKS
1	93332-00081	BEARING	1	1	1	
2	93332-00068	BEARING	1	1	1	
3	4EW-23416-00	COVER, BALL RACE 2	1	1	1	
4	90179-28650	NUT	1	1	1	
5	90201-286K9	WASHER, PLATE	2	2	2	
6	5TJ-23435-80	CROWN, HANDLE	1	1	1	
7	90170-24373	NUT	1	1	1	
8	90201-247L2	WASHER, PLATE	1	1	1	
9	5TJ-2319U-00	CAP	1	1	1	
10	5XE-23441-00	HOLDER, HANDLE UPPER	2	2	2	
11	95027-08035	BOLT, FLANGE	4	4	4	
12	95027-08040	BOLT, FLANGE	4	4	4	
13	5TJ-8350E-80	BRACKET	1	1	1	
14	5TJ-2831V-80	STAY, HEAD LIGHT 1	1	1	1	
15	5TJ-2331E-80	GUIDE, CABLE	1	1	1	
16	90105-05361	BOLT, FLANGE	1	1	1	
17	5TJ-23389-80	GUIDE, CABLE	1	1	1	
18	95027-06020	BOLT, FLANGE	1	1	1	
19	5XE-23113-00	COLLAR	1	1	1	



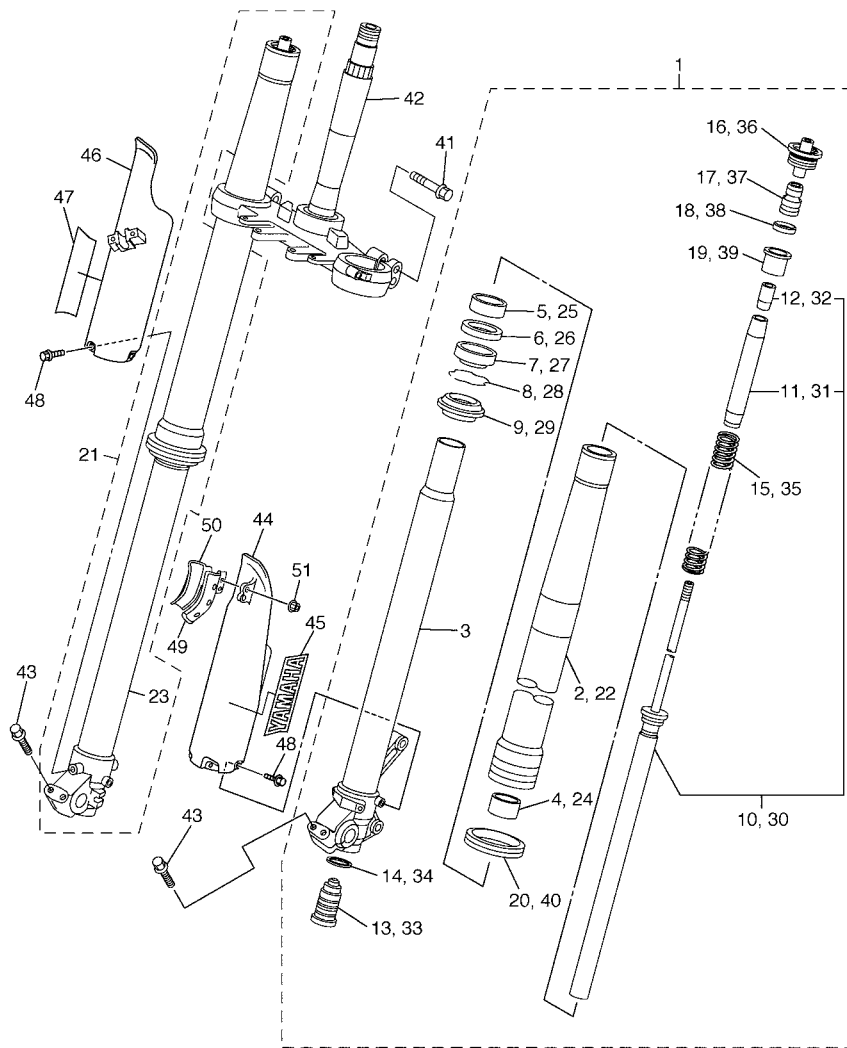
5TJ8100-D260



5TJ8100-D270

FIG. 27 FRONT FORK

REF. NO.	PART NO.	DESCRIPTION	5TJ8	5TJ9	5TJA	REMARKS
1	5TJ-23102-L0	FRONT FORK ASSY (L.H)	1		1	UR FOR USA,CAN
	5TJ-23102-90	FRONT FORK ASSY (L.H)		1		
	5TJ-23102-A0	FRONT FORK ASSY (L.H)			1	UR FOR OCE,ZAF
2	5TJ-23136-L0	.TUBE, OUTER	1	1	1	
3	5TJ-23120-L0	.INNER TUBE COMP.2	1		1	FOR USA,CAN
	5TJ-23120-90	.INNER TUBE COMP.2		1	1	FOR EUR,OCE,ZAF
4	5XE-23171-L0	.PISTON, FRONT FORK	1	1	1	
5	5XE-23125-L0	.METAL, SLIDE 1	1	1	1	
6	5XE-23146-L0	.WASHER, OIL SEAL	1	1	1	
7	1C3-23145-L0	.OIL SEAL	1	1	1	
8	5XE-23153-L0	.RING, SNAP	1	1	1	
9	5XE-23144-L0	.SEAL, DUST	1	1	1	
10	5TJ-23170-80	.CYLINDER COMP., FRONT FORK	1		1	FOR USA,CAN
	5TJ-23170-90	.CYLINDER COMP., FRONT FORK		1	1	FOR EUR,OCE,ZAF
11	5TJ-23142-L0	..SEAT, SPRING UPPER	1	1	1	
12	5HD-23393-L0	..NUT, SPECIAL	1	1	1	
13	5TJ-2316A-80	.VALVE COMP.	1		1	UR FOR USA,CAN
	5TJ-2316A-90	.VALVE COMP.		1		
	5TJ-2316A-A0	.VALVE COMP.			1	UR FOR OCE,ZAF
14	3JD-23158-L0	.GASKET	1	1	1	
15	5TJ-23141-L0	.SPRING,FRONT FORK(K=4.5N/MM)	1		1	UR FOR USA,CAN
	5TJ-23141-90	.SPRING,FRONT FORK(K=4.2N/MM)		1		
	5TJ-23141-A0	.SPRING,FRONT FORK(K=4.4N/MM)			1	UR FOR OCE,ZAF
16	5XE-23111-L0	.BOLT, CAP	1	1	1	
17	5MV-23195-L0	.RUBBER	1	1	1	
18	5TJ-23149-L0	.WASHER, SPRING UPPER	1	1	1	
19	5TJ-23118-L0	.SPACER	1	1	1	



5TJ8100-D270

FIG. 27 FRONT FORK

REF. NO.	PART NO.	DESCRIPTION	5TJ8	5TJ9	5TJA	REMARKS
20	1C3-2314F-L0	.PROTECTOR GUIDE COMP, 1	1	1	1	
21	5TJ-23103-L0	FRONT FORK ASSY (R.H)	1	1		UR FOR USA,CAN
	5TJ-23103-90	FRONT FORK ASSY (R.H)		1		
	5TJ-23103-A0	FRONT FORK ASSY (R.H)			1	UR FOR OCE,ZAF
22	5TJ-23136-L0	.TUBE, OUTER	1	1	1	
23	5TJ-23110-L0	.INNER TUBE COMP.1	1	1	1	FOR USA,CAN
	5TJ-23110-90	.INNER TUBE COMP.1		1	1	FOR EUR,OCE,ZAF
24	5XE-23171-L0	.PISTON, FRONT FORK	1	1	1	
25	5XE-23125-L0	.METAL, SLIDE 1	1	1	1	
26	5XE-23146-L0	.WASHER, OIL SEAL	1	1	1	
27	1C3-23145-L0	.OIL SEAL	1	1	1	
28	5XE-23153-L0	.RING, SNAP	1	1	1	
29	5XE-23144-L0	.SEAL, DUST	1	1	1	
30	5TJ-23170-80	.CYLINDER COMP., FRONT FORK	1	1		FOR USA,CAN
	5TJ-23170-90	.CYLINDER COMP., FRONT FORK		1	1	FOR EUR,OCE,ZAF
31	5TJ-23142-L0	..SEAT, SPRING UPPER	1	1	1	
32	5HD-23393-L0	..NUT, SPECIAL	1	1	1	
33	5TJ-2316A-80	.VALVE COMP.	1	1		UR FOR USA,CAN
	5TJ-2316A-90	.VALVE COMP.		1		
	5TJ-2316A-A0	.VALVE COMP.			1	UR FOR OCE,ZAF
34	3JD-23158-L0	.GASKET	1	1	1	
35	5TJ-23141-L0	.SPRING,FRONT FORK(K=4.5N/MM)	1	1		UR FOR USA,CAN
	5TJ-23141-90	.SPRING,FRONT FORK(K=4.2N/MM)		1		
	5TJ-23141-A0	.SPRING,FRONT FORK(K=4.4N/MM)			1	UR FOR OCE,ZAF
36	5XE-23111-L0	.BOLT, CAP	1	1	1	
37	5MV-23195-L0	.RUBBER	1	1	1	
38	5TJ-23149-L0	.WASHER, SPRING UPPER	1	1	1	

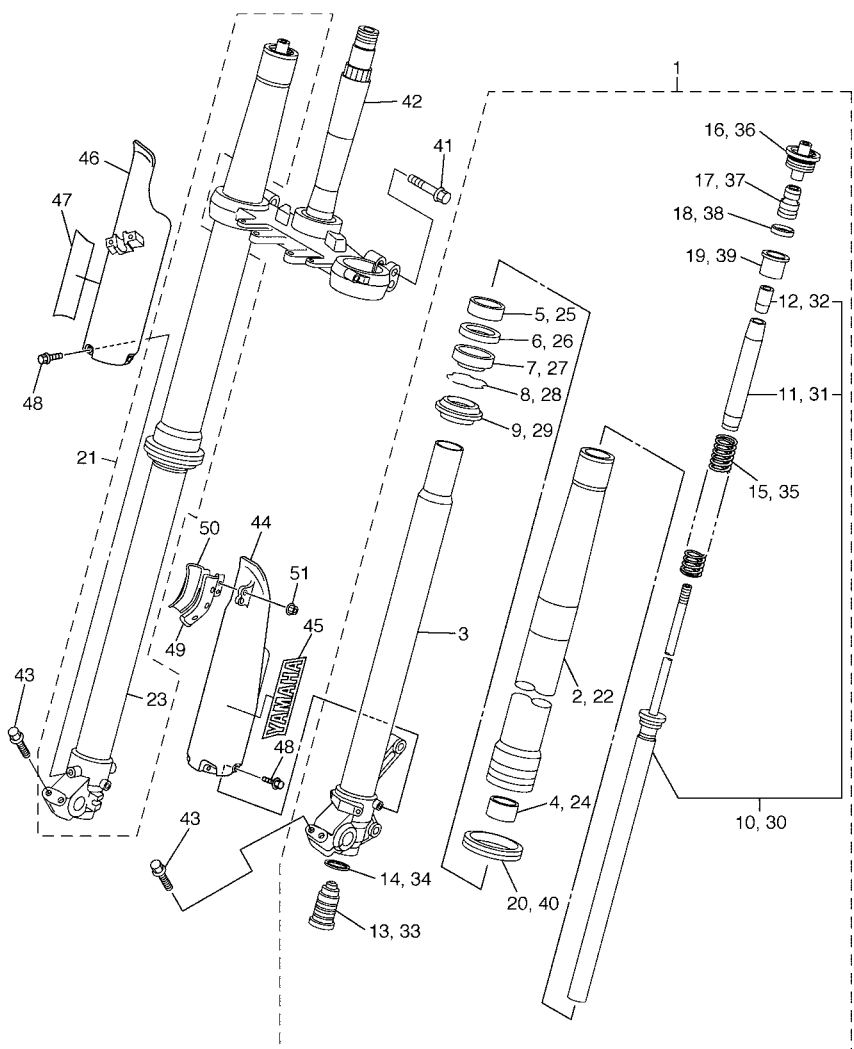


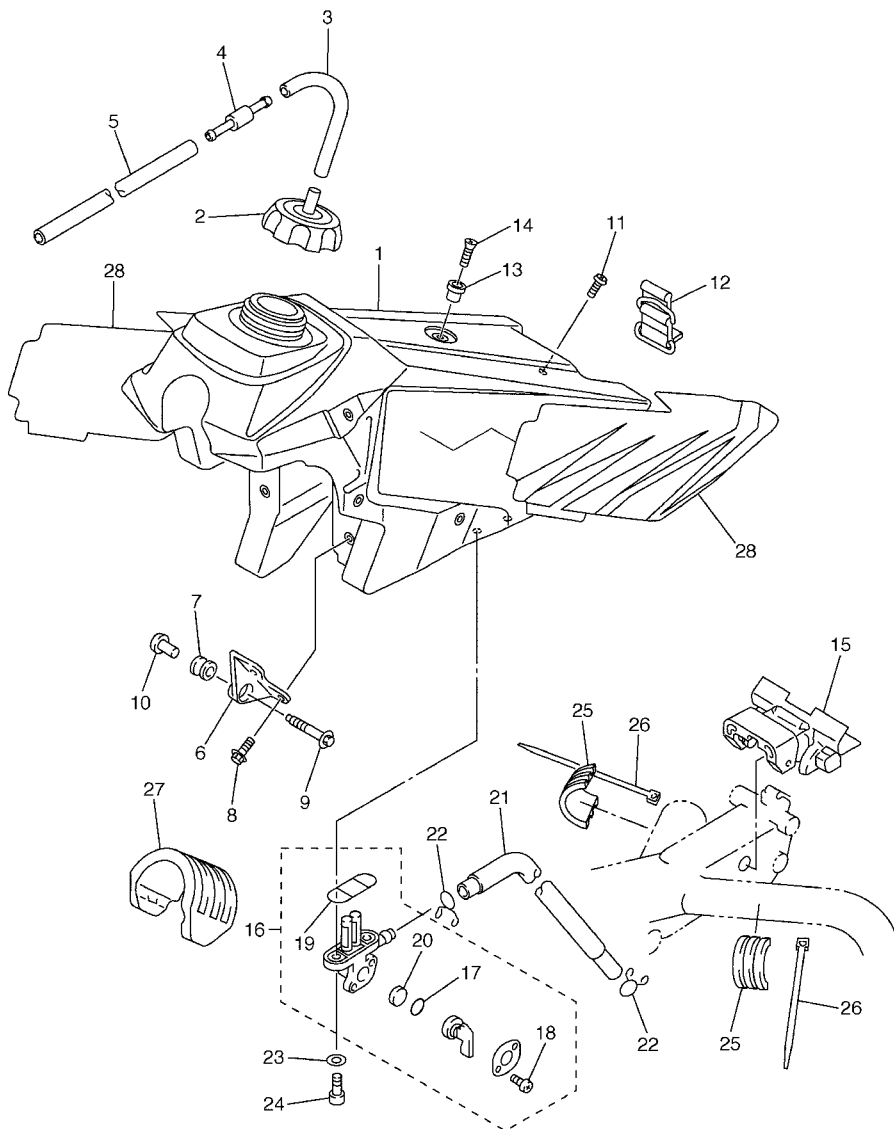
FIG. 27 FRONT FORK

REF. NO.	PART NO.	DESCRIPTION	5TJ8	5TJ9	5TJA	REMARKS
39	5TJ-23118-L0	.SPACER	1	1	1	
40	1C3-2314F-L0	.PROTECTOR GUIDE COMP, 1	1	1	1	
41	5NY-23346-L0	BOLT 1	4	4	4	
42	5TJ-23340-L0	UNDER BRACKET COMP.	1	1	1	
43	95027-08040	BOLT, FLANGE	4	4	4	
44	5TJ-2315J-80	PROTECTOR 2	1	1	1	
45	4XL-2153A-10	EMBLEM, YAMAHA	1	1	1	
46	1C3-2315H-00	PROTECTOR 1	1	1	1	
47	4XL-2153A-10	EMBLEM, YAMAHA	1	1	1	
48	3SP-23356-L0	BOLT 2	6	6	6	
49	1C3-23466-00	CLAMP	1	1	1	
50	1C3-23467-00	CLAMP	1	1	1	
51	95707-06500	NUT, FLANGE	2	2	2	

 5TJ8100-D270

FIG. 28 FUEL TANK

REF. NO.	PART NO.	DESCRIPTION	5TJ8	5TJ9	5TJA	REMARKS
1	5TJ-24110-80	FUEL TANK COMP.	1	1	1	
2	5NY-24610-00	CAP ASSY	1	1	1	
3	90445-09220	HOSE (L30)	1	1	1	
4	3XJ-24380-00	PIPE JOINT ASSY	1	1	1	
5	90445-09100	HOSE	1	1	1	
6	5XE-24144-00	HOLDER, DAMPER	2	2	2	
7	90480-18549	GROMMET	2	2	2	
8	95027-06016	BOLT, FLANGE	4	4	4	
9	5XE-24176-00	BOLT 1	2	2	2	
10	5NY-24186-00	WASHER, SPECIAL	2	2	2	
11	98907-06025	SCREW, BIND	1	1	1	
12	5SF-24173-00	BAND, TANK FITTING 1	1	1	1	
13	4EW-2412F-00	BRACKET, SEAT	1	1	1	
14	98707-06025	SCREW, FLAT HEAD	1	1	1	
15	5TJ-24181-00	DAMPER, LOCATING 1	1	1	1	
16	2GU-24500-02	FUEL COCK ASSY 1	1	1	1	
17	3AJ-24534-01	.SEAL, COCK	1	1	1	
18	98507-03008	.SCREW, PAN HEAD	2	2	2	
19	4X8-24512-00	.O-RING	1	1	1	
20	3AC-24523-00	.VALVE PACKING	1	1	1	
21	90445-11185	HOSE	1	1	1	
22	90467-10008	CLIP	2	2	2	
23	90202-05193	WASHER, PLATE	2	2	2	
24	90149-06011	SCREW	2	2	2	
25	5NY-24183-00	DAMPER, LOCATING 3	2	2	2	
26	90465-13152	CLAMP	2	2	2	
27	5BE-24182-00	DAMPER, LOCATING 2	1	1	1	



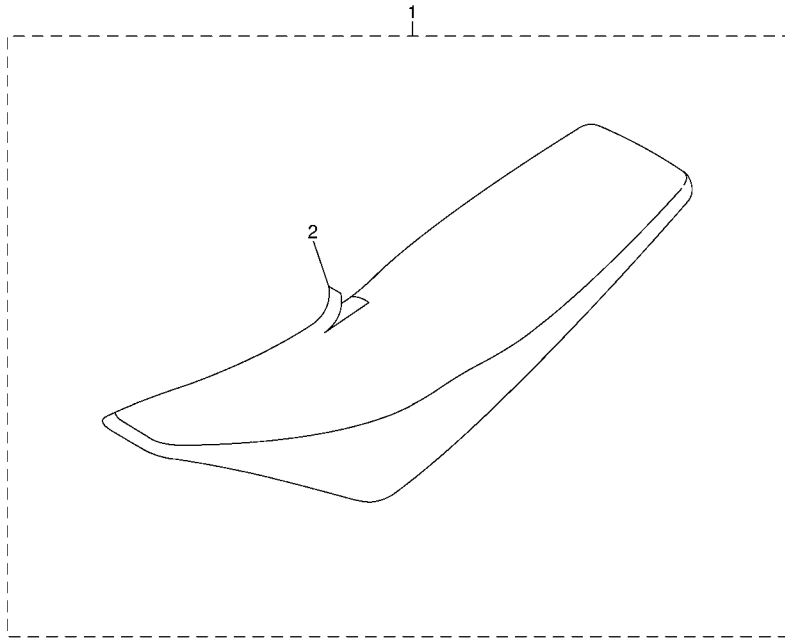
5TJ8100-D280



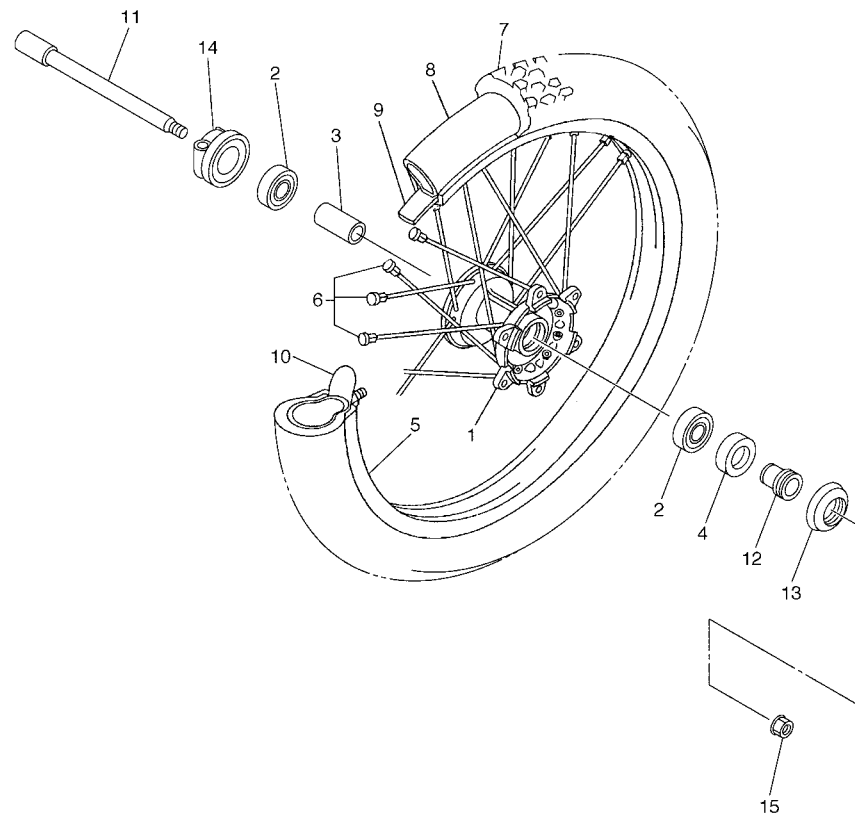


**FIG. 29 SEAT**

REF. NO.	PART NO.	DESCRIPTION	5TJ8	5TJ9	5TJA	REMARKS
1	5TJ-24710-80	SINGLE SEAT ASSY	1	1	1	
2	5TJ-2470F-80	.SEAT COVER COMP.	1	1	1	



5XD1100-C270



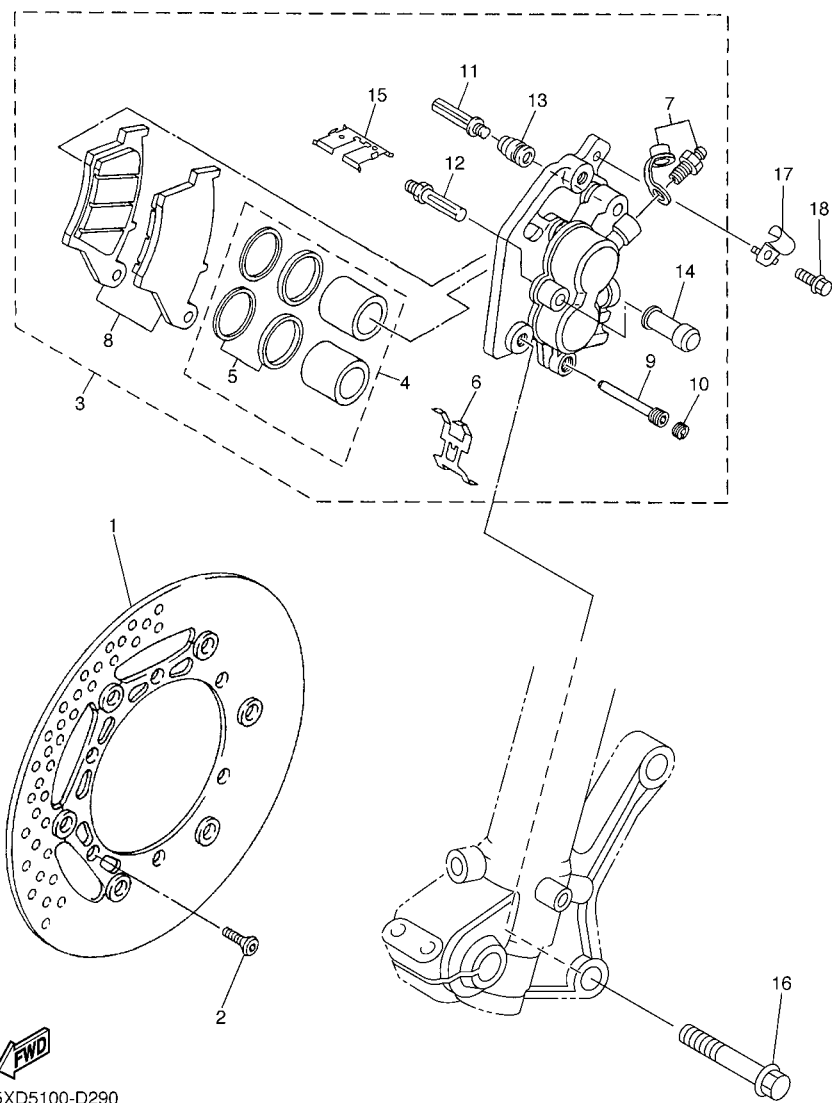
**FIG. 30 FRONT WHEEL**

REF. NO.	PART NO.	DESCRIPTION	5TJ8	5TJ9	5TJA	REMARKS
1	5NG-25111-50	HUB, FRONT	1	1	1	
2	93306-90403	BEARING	2	2	2	
3	5NY-25117-00	SPACER, BEARING	1	1	1	
4	93102-26468	OIL SEAL	1	1	1	
5	94416-21003	RIM (1.60-21)	1	1	1	
6	5NY-25104-00	SPOKE SET, FRONT	1	1	1	
7	94108-21015	TIRE (80/100-21 51M D739FA)	1	1	1	DUNLOP(CAN,ZAF)
	94109-21009	TIRE (90/90-21 M/C 54R D908F)		1	1	DUNLOP(OCE)
8	94227-21101	TUBE (80/100-21 M/C TR4)	1	1	1	DUNLOP
9	94309-21161	BAND, RIM (1.60-21)	1	1	1	DUNLOP
10	5SF-25394-00	SPACER, BEAD	1	1	1	
11	1C3-25181-00	AXLE, WHEEL	1	1	1	
12	5TJ-25183-80	COLLAR, WHEEL	1	1	1	
13	5TJ-25118-80	COVER, HUB DUST	1	1	1	
14	5NG-25190-50	GEAR UNIT ASSY	1	1	1	
15	90179-16002	NUT	1	1	1	

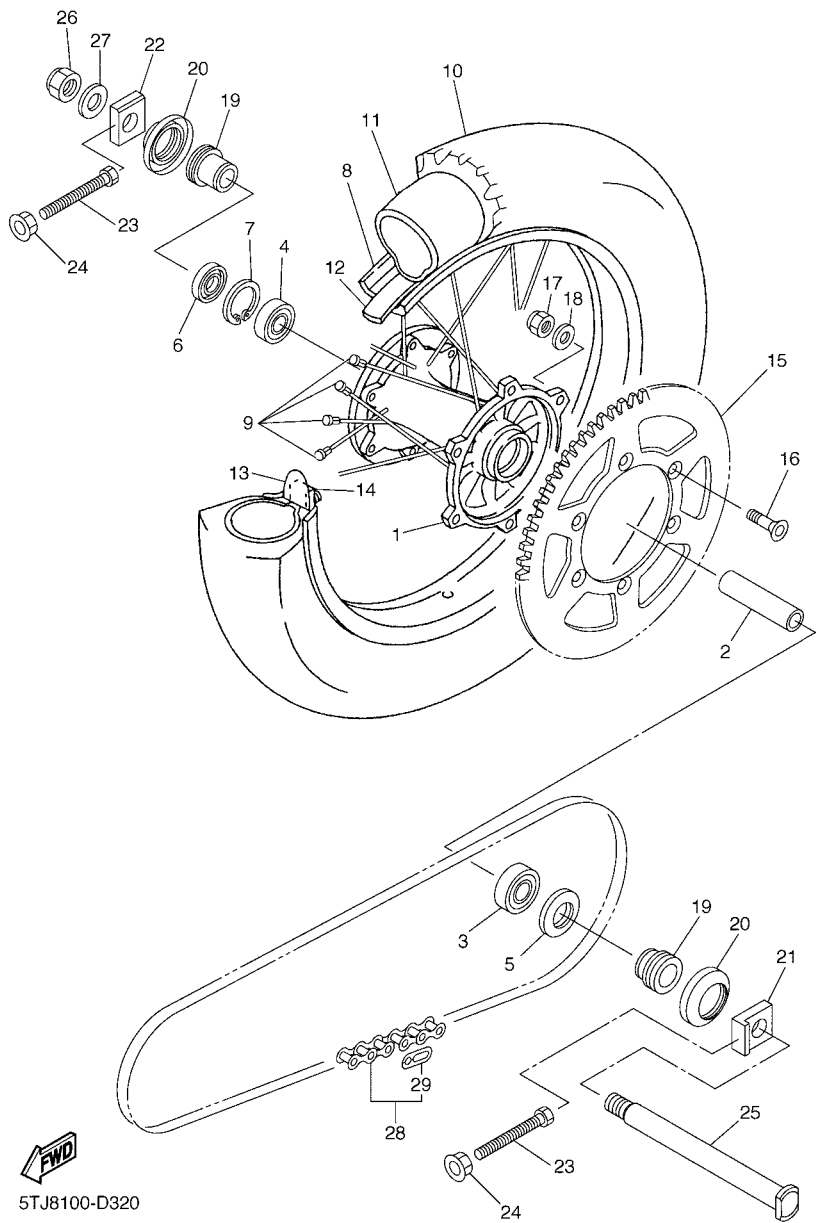


5TJ8100-D300

**FIG. 31 FRONT BRAKE CALIPER**



REF. NO.	PART NO.	DESCRIPTION	5TJ8	5TJ9	5TJA	REMARKS
1	5MV-2581T-00	DISK BRAKE ASSY	1	1	1	
2	90149-06327	SCREW	6	6	6	
3	1C3-2580T-00	CALIPER ASSY (LEFT)	1	1	1	
4	5UN-W0057-00	.PISTON ASSY, CALIPER	1	1	1	
5	3JD-W0047-00	..CALIPER SEAL KIT	1	1	1	
6	5DH-25919-00	.SUPPORT, PAD	1	1	1	
7	1UY-W0048-50	.BLEED SCREW KIT	1	1	1	
8	5MV-W0045-01	.BRAKE PAD KIT	1	1	1	
9	5DH-25933-00	.PIN, PAD	1	1	1	
10	5DH-25916-00	.PLUG	1	1	1	
11	3SP-25926-51	.BOLT	1	1	1	
12	3SP-25914-51	.PIN, SLIDE	1	1	1	
13	3JD-25917-00	.BOOT, CALIPER	1	1	1	
14	1UY-25937-51	.BOOT 2	1	1	1	
15	5DH-25849-00	.RETAINER, CALIPER	1	1	1	
16	90105-08659	BOLT, FLANGE	2	2	2	
17	1C3-25875-00	HOLDER, BRAKE HOSE 1	1	1	1	
18	95027-06010	BOLT, FLANGE	1	1	1	

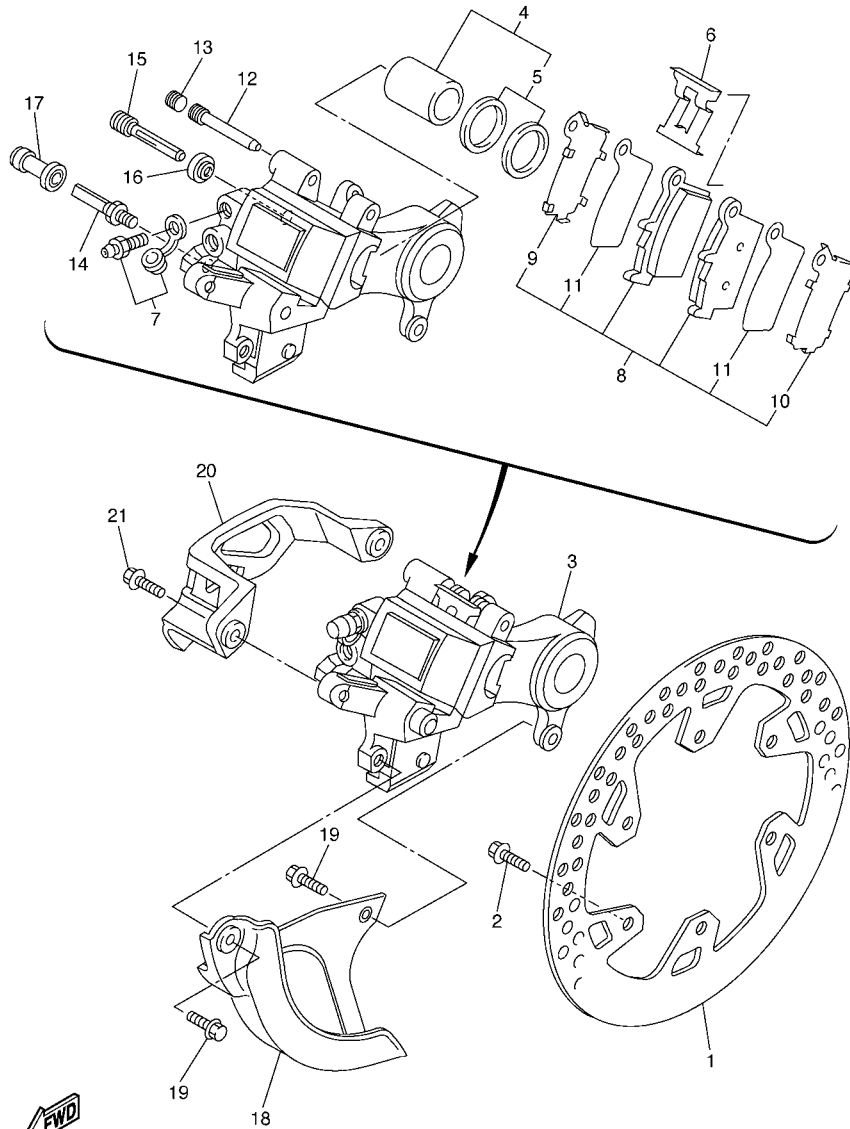


5TJ8100-D320

FIG. 32 REAR WHEEL

REF. NO.	PART NO.	DESCRIPTION	5TJ8	5TJ9	5TJA	REMARKS
1	5ET-25311-00	HUB, REAR	1	1	1	
2	5ET-25317-00	SPACER, BEARING	1	1	1	
3	93306-27205	BEARING	1	1	1	
4	93306-07202	BEARING	1	1	1	
5	93106-30001	OIL SEAL	1	1	1	
6	93106-30045	OIL SEAL	1	1	1	
7	99009-45500	CIRCLIP	1	1	1	
8	94421-18610	RIM (2.15-18)	1	1	1	
9	5GS-25304-00	SPOKE SET, REAR	1	1	1	
10	94111-18012	TIRE (110/100-18 64M D756)	1	1	1	DUNLOP(CAN,ZAF)
	94113-18015	TIRE (130/90-18 M/C 69R D908)	1	1	1	DUNLOP(OCE)
11	94212-18188	TUBE (110-140/80-100-18 M/C)	1	1	1	DUNLOP(CAN,ZAF)
	94213-18012	TUBE (4.50,5.10,130/90-18)	1	1	1	DUNLOP(OCE)
12	94309-18146	BAND, RIM (2.15-18)	1	1	1	DUNLOP
13	3JE-25394-00	SPACER, BEAD	2	2	2	
14	4XM-25364-00	DAMPER	2	2	2	
15	5TJ-25450-80	SPROCKET, DRIVEN (50T)	1	1	1	STD FOR CAN,ZAF
	1C3-25450-00	SPROCKET, DRIVEN (50T)			1	STD FOR OCE
	5GS-25448-50	SPROCKET, DRIVEN (48T)	1	1	1	AP FOR CAN,ZAF
	5TJ-25452-80	SPROCKET, DRIVEN (52T)	1	1	1	AP FOR CAN,ZAF
	1C3-25448-00	SPROCKET, DRIVEN (48T)			1	AP FOR OCE
	1C3-25449-00	SPROCKET, DRIVEN (49T)			1	AP FOR OCE
	1C3-25451-00	SPROCKET, DRIVEN (51T)			1	AP FOR OCE
	1C3-25452-00	SPROCKET, DRIVEN (52T)			1	AP FOR OCE
16	90109-081G1	BOLT	6	6	6	
17	90185-08169	NUT, SELF-LOCKING	6	6	6	
18	90201-08326	WASHER, PLATE	6	6	6	

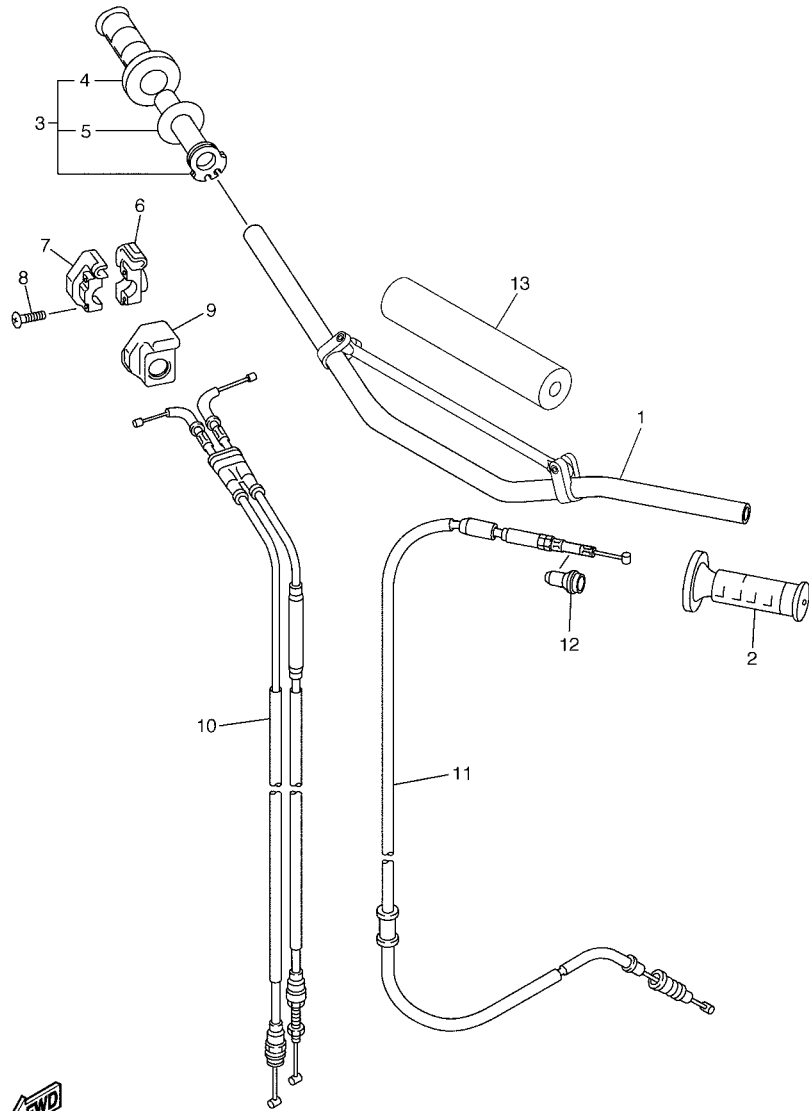




5XD5100-D310

FIG. 33 REAR BRAKE CALIPER

REF. NO.	PART NO.	DESCRIPTION	5TJ8	5TJ9	5TJA	REMARKS
1	5NY-2582W-00	DISK, REAR BRAKE 2	1	1	1	
2	90109-065G4	BOLT	6	6	6	
3	1C3-2580W-00	CALIPER ASSY, REAR 2	1	1	1	
4	5UN-W0057-50	.PISTON ASSY, CALIPER	1	1	1	
5	5UN-W0047-50	..CALIPER SEAL KIT	1	1	1	
6	5DH-25919-50	..SUPPORT, PAD	1	1	1	
7	1UY-W0048-50	.BLEED SCREW KIT	1	1	1	
8	1C3-W0046-00	.BRAKE PAD KIT 2	1	1	1	
9	5UN-25828-60	..SHIM, CALIPER	1	1	1	
10	5UN-25827-60	..SHIM, CALIPER	1	1	1	
11	5UN-22898-60	..INSULATOR, HEAT	2	2	2	
12	8CR-25924-00	.PIN, PAD	1	1	1	
13	5DH-25916-00	.PLUG	1	1	1	
14	5UN-25914-00	.PIN, SLIDE	1	1	1	
15	5DH-25914-50	.PIN, SLIDE	1	1	1	
16	3JD-25917-00	.BOOT, CALIPER	1	1	1	
17	1UY-25937-51	.BOOT 2	1	1	1	
18	5DH-25718-01	PROTECTOR, DISK BRAKE	1	1	1	
19	95027-06012	BOLT, FLANGE	2	2	2	
20	5TA-27491-00	PROTECTOR	1	1	1	
21	95027-06016	BOLT, FLANGE	2	2	2	

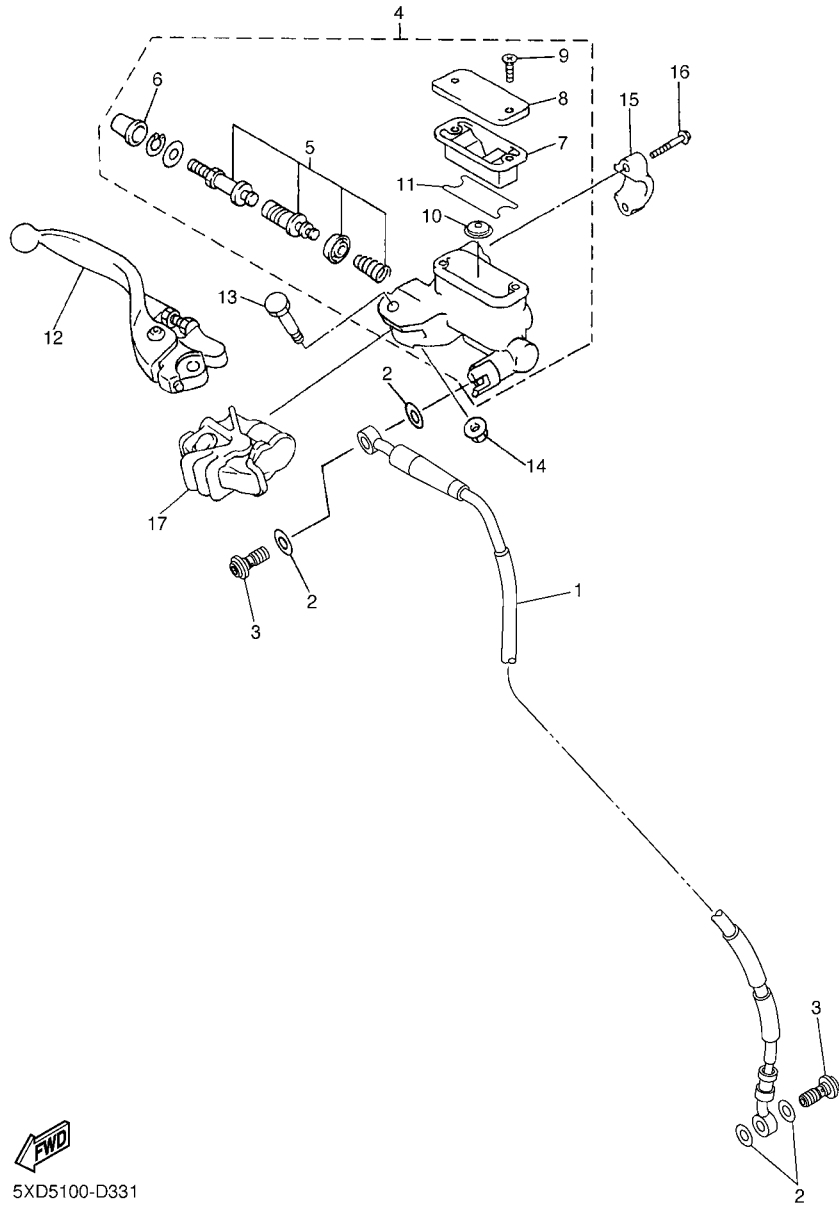


5TJ8100-D340

FIG. 34 STEERING HANDLE & CABLE

REF. NO.	PART NO.	DESCRIPTION	5TJ8	5TJ9	5TJA	REMARKS
1	1C3-26111-00	HANDLEBAR	1	1	1	
2	4GY-26241-00	GRIP	1	1	1	
3	5BE-26240-00	GRIP ASSY	1	1	1	
4	4GY-26242-00	.GRIP (RIGHT)	1	1	1	
5	3Y1-26249-00	.RING, LEAF	1	1	1	
6	5BE-26281-00	CAP, GRIP UPPER	1	1	1	
7	5BE-26282-00	CAP, GRIP LOWER	1	1	1	
8	98507-05020	SCREW, PAN HEAD	2	2	2	
9	5SF-26287-00	COVER, CAP GRIP	1	1	1	
10	5XD-26302-00	THROTTLE CABLE ASSY	1	1	1	
11	5TJ-26335-80	CABLE, CLUTCH	1	1	1	
12	5HD-26342-00	BOOT, CABLE	1	1	1	
13	1C3-26124-00	PROTECTOR, HANDLEBAR	1	1	1	



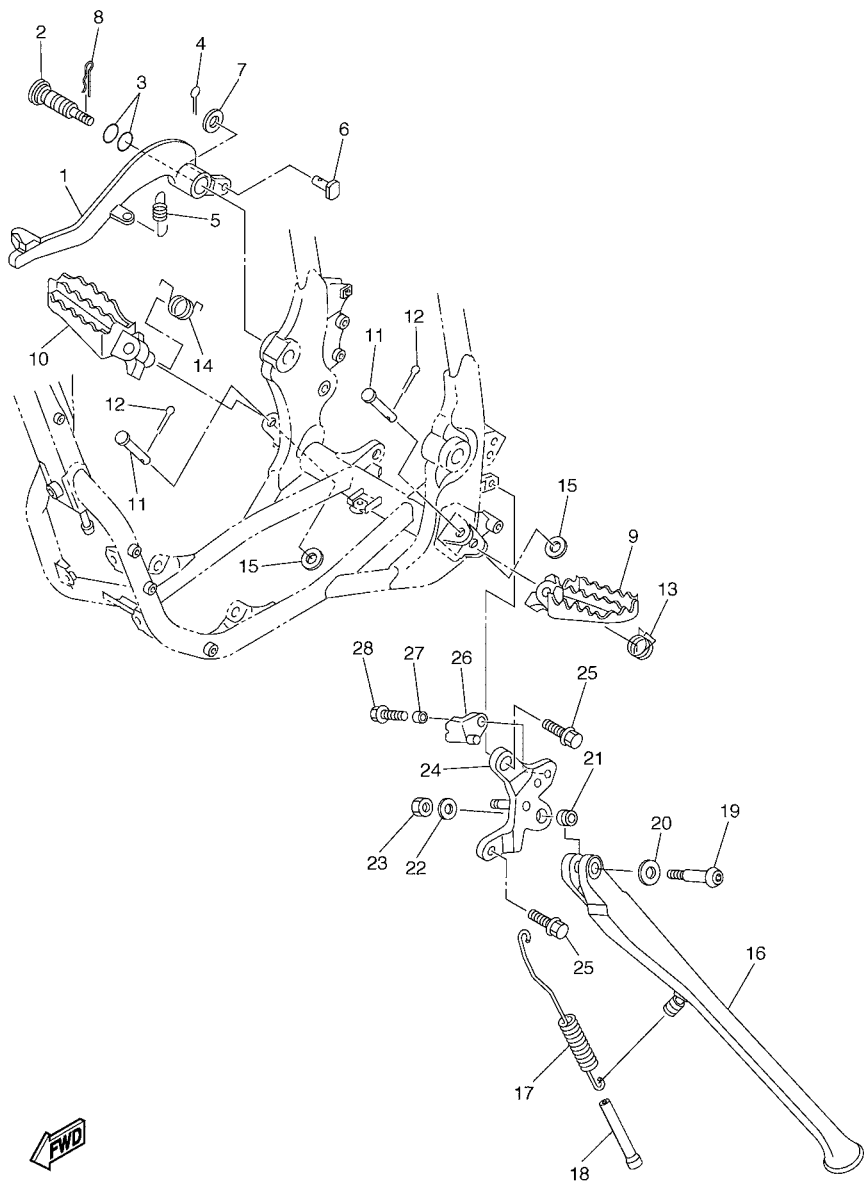


5XD5100-D331

FIG. 35 FRONT MASTER CYLINDER

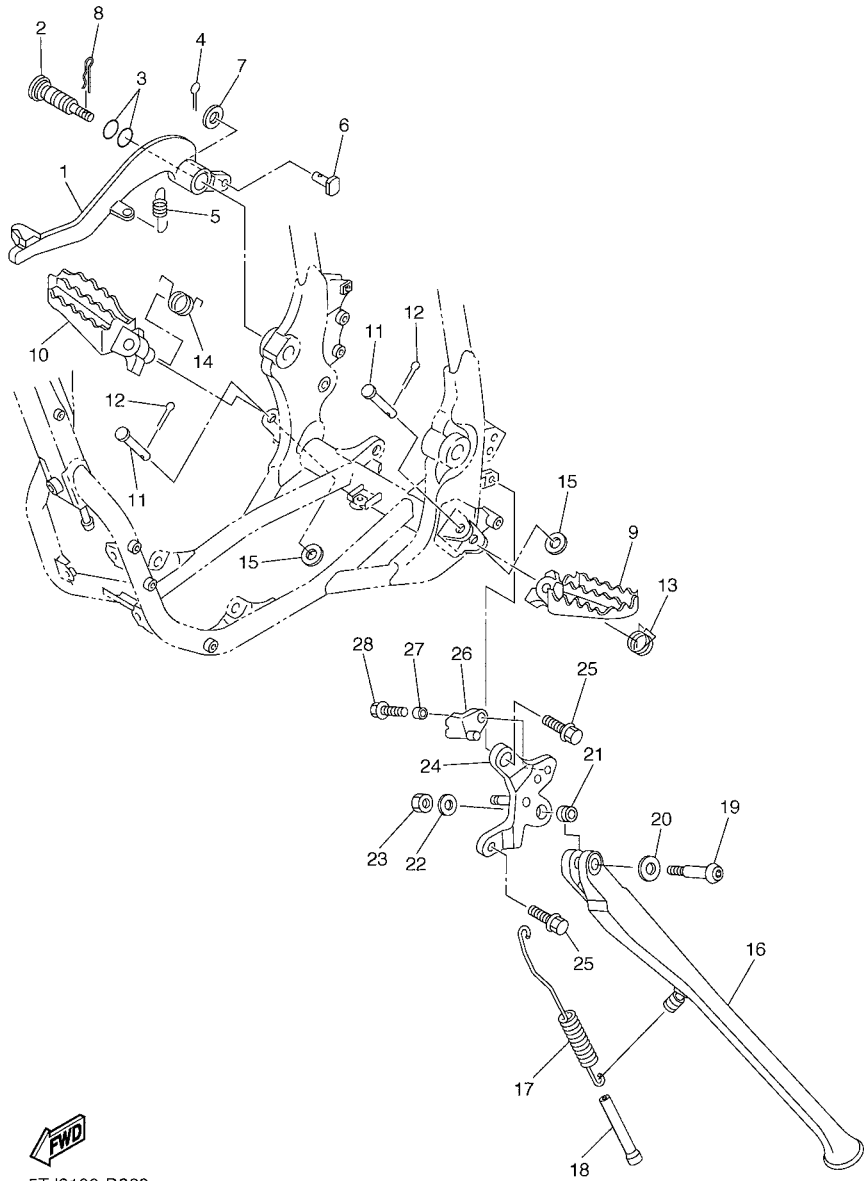
REF. NO.	PART NO.	DESCRIPTION	5TJ8	5TJ9	5TJA	REMARKS
1	5TJ-25872-80	HOSE, BRAKE 1	1	1	1	
2	90201-10118	WASHER, PLATE	4	4	4	
3	90401-10172	BOLT, UNION	2	2	2	
4	5XE-W2587-00	MASTER CYLINDER SUB ASSY	1	1	1	
5	5NY-W0041-00	.CYLINDER KIT, MASTER	1	1	1	
6	5NY-25868-00	.BOOT, MASTER CYLINDER	1	1	1	
7	5XE-25854-00	.DIAPHRAGM, RESERVOIR	1	1	1	
8	5MV-25852-01	.CAP, RESERVOIR	1	1	1	
9	98706-04012	.SCREW, FLAT HEAD	2	2	2	
10	5CG-25715-00	.SEPARATOR ASSY	1	1	1	
11	5XE-25853-00	.FLOAT, RESERVOIR	1	1	1	
12	5MV-83922-00	LEVER 2	1	1	1	
13	5MV-2589F-00	BOLT, LEVER	1	1	1	
14	95701-06500	NUT, FLANGE	1	1	1	
15	5MV-25867-00	BRACKET, MASTER CYLINDER	1	1	1	
16	5MV-25833-00	BOLT, FITTING	2	2	2	
17	5NY-26372-00	COVER, HANDLE LEVER 1	1	1	1	

FIG. 36 STAND & FOOTREST



5TJ8100-D360

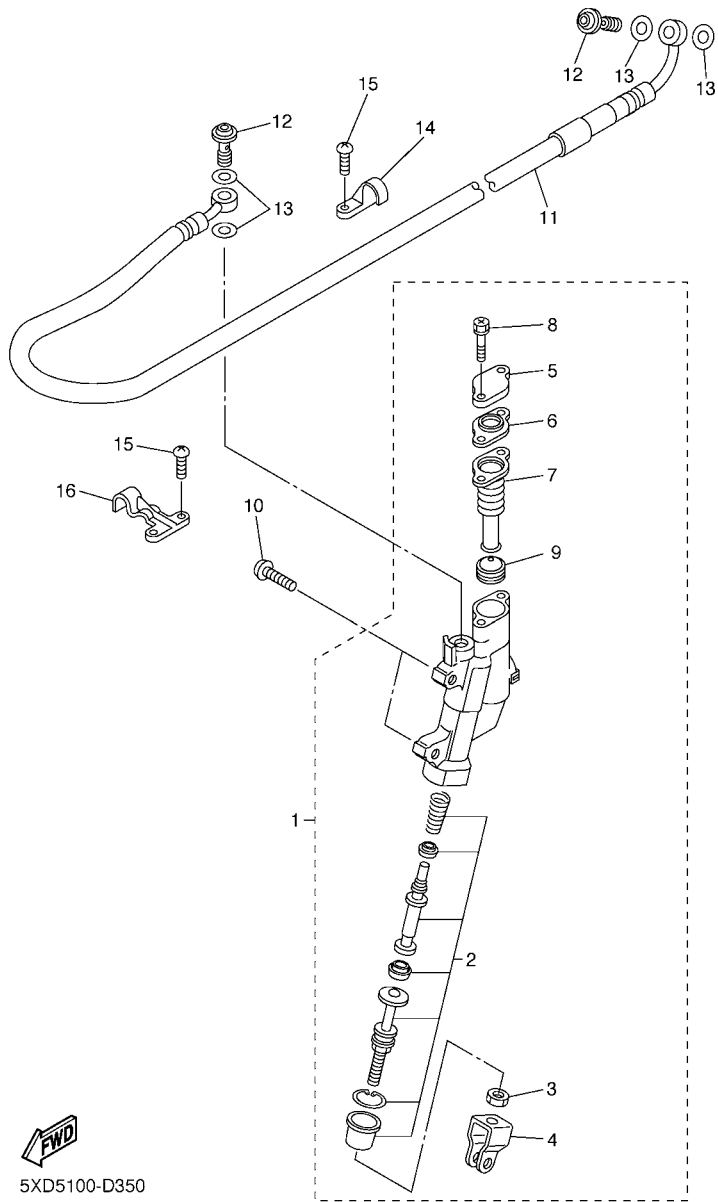
REF. NO.	PART NO.	DESCRIPTION	5TJ8	5TJ9	5TJA	REMARKS
1	5TA-27200-00	PEDAL, BRAKE	1	1	1	
2	1C3-27217-00	BOLT	1	1	1	
3	93210-11073	O-RING	2	2	2	
4	91401-20012	PIN, COTTER	1	1	1	
5	90506-16500	SPRING, TENSION	1	1	1	
6	90240-08120	PIN, CLEVIS	1	1	1	
7	90201-08089	WASHER, PLATE	1	1	1	
8	90468-16099	CLIP	1	1	1	
9	5ET-27411-00	FOOTREST 1	1	1	1	
10	5ET-27421-00	FOOTREST 2	1	1	1	
11	90240-10142	PIN, CLEVIS	2	2	2	
12	91401-25015	PIN, COTTER	2	2	2	
13	90508-282B8	SPRING, TORSION	1	1	1	
14	90508-282B9	SPRING, TORSION	1	1	1	
15	90201-10119	WASHER, PLATE	2	2	2	
16	5TJ-27311-80	STAND, SIDE	1	1	1	
17	90506-30002	SPRING, TENSION	1	1	1	
18	5TJ-27414-80	DAMPER, FOOTREST	1	1	1	
19	90109-08051	BOLT	1	1	1	
20	92990-10200	WASHER, PLAIN	1	1	1	
21	90387-1003G	COLLAR	1	1	1	
22	90201-086P8	WASHER, PLATE	1	1	1	
23	90185-08055	NUT, SELF-LOCKING	1	1	1	
24	5TJ-21458-50	BRACKET, SIDE STAND	1	1	1	
25	95027-10020	BOLT, FLANGE	2	2	2	
26	5TJ-27314-50	STOPPER	1	1	1	
27	90387-06M24	COLLAR	1	1	1	



5TJ8100-D360

FIG. 36 STAND & FOOTREST

REF. NO.	PART NO.	DESCRIPTION	5TJ8	5TJ9	5TJA	REMARKS
28	95807-06016	BOLT, FLANGE	1	1	1	



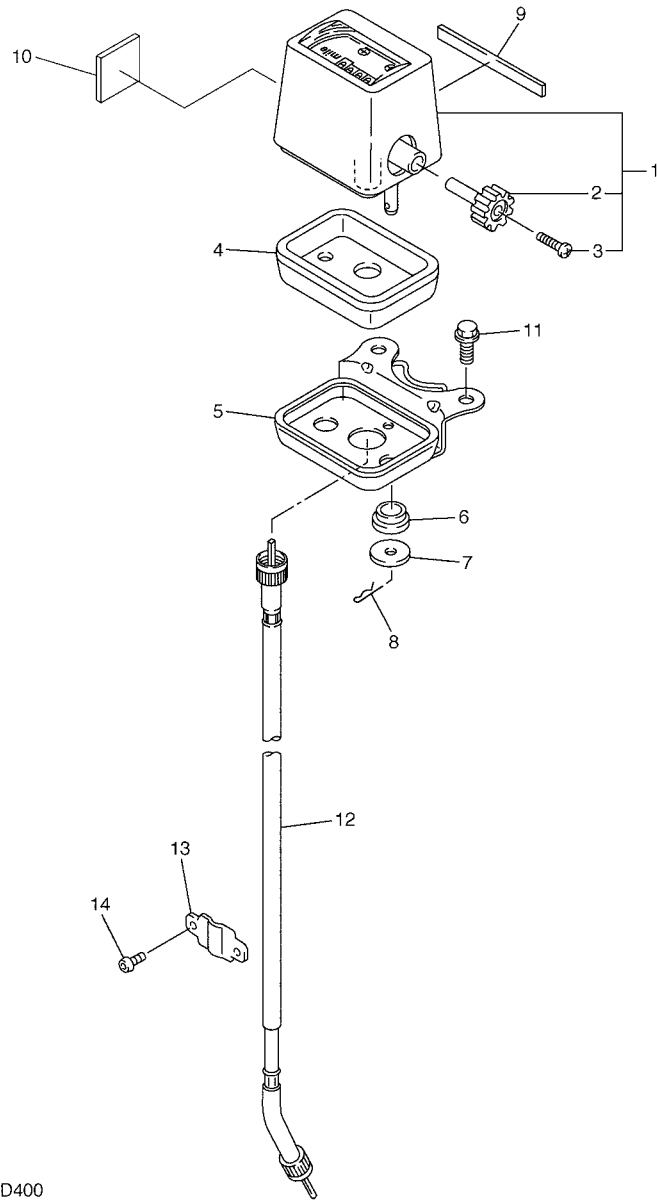
5XD5100-D350

FIG. 37 REAR MASTER CYLINDER

REF. NO.	PART NO.	DESCRIPTION	5TJ8	5TJ9	5TJA	REMARKS
1	5UN-2583V-00	RR. MASTER CYLINDER ASSY.	1	1	1	
2	5UN-W0042-50	.CYLINDER KIT, MASTER	1	1	1	
3	5UN-27218-00	.NUT	1	1	1	
4	5UN-27222-00	.JOINT	1	1	1	
5	5UN-25852-50	.CAP, RESERVOIR	1	1	1	
6	5UN-2585B-00	.PLATE, DIAPHRAGM	1	1	1	
7	5UN-25854-00	.DIAPHRAGM, RESERVOIR	1	1	1	
8	5UN-27217-00	.BOLT	2	2	2	
9	5CG-25715-00	.SEPARATOR ASSY	1	1	1	
10	90111-06029	BOLT	2	2	2	
11	5UN-25873-00	HOSE, BRAKE 2	1	1	1	
12	90401-10172	BOLT, UNION	2	2	2	
13	90201-10118	WASHER, PLATE	4	4	4	
14	2VM-25876-00	HOLDER, BRAKE HOSE 2	1	1	1	
15	98507-05010	SCREW, PAN HEAD	4	4	4	
16	1C3-25876-00	HOLDER, BRAKE HOSE 2	1	1	1	



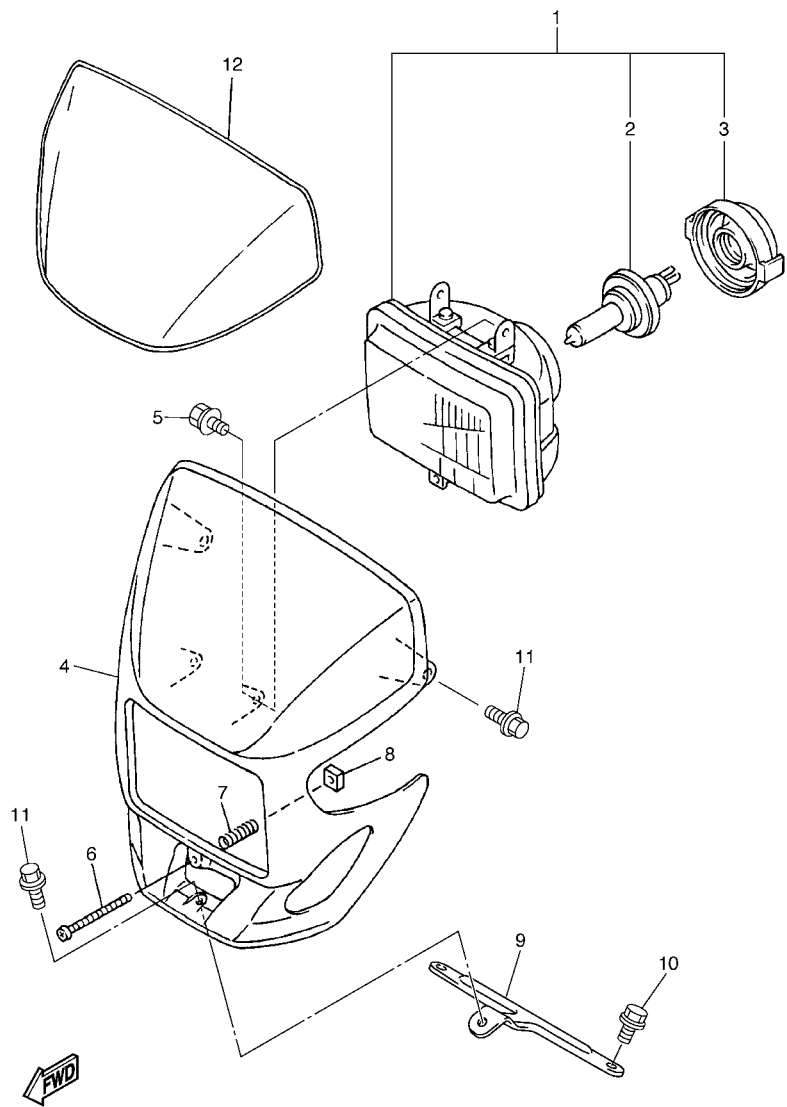




**FWD**  
5TJ8100-D400

**FIG. 40 METER**

REF. NO.	PART NO.	DESCRIPTION	5TJ8	5TJ9	5TJA	REMARKS
1	5TJ-8355W-10	TRIP METER COMP. (MILE)	1	1		FOR GBR
	5TJ-8355W-00	TRIP METER COMP. (KM/H)		1	1	
2	1AE-83578-00	.KNOB, TRIP METER	1	1	1	
3	90157-02031	.SCREW, PAN HEAD	1	1	1	
4	4V5-83513-00	DAMPER	1	1	1	
5	5NG-83519-00	BRACKET, METER	1	1	1	
6	1M1-83526-00	DAMPER 2	2	2	2	
7	90201-05033	WASHER, PLATE	2	2	2	
8	437-83525-00	CLIP	2	2	2	
9	2HR-83592-00	DAMPER	1	1	1	
10	5TJ-83513-80	DAMPER	1	1	1	
11	95027-06012	BOLT, FLANGE	2	2	2	
12	5BF-83550-00	SPEEDOMETER CABLE ASSY	1	1	1	
13	5BF-2317M-00	STAY 3	1	1	1	
14	92017-05008	BOLT, BUTTON HEAD	2	2	2	

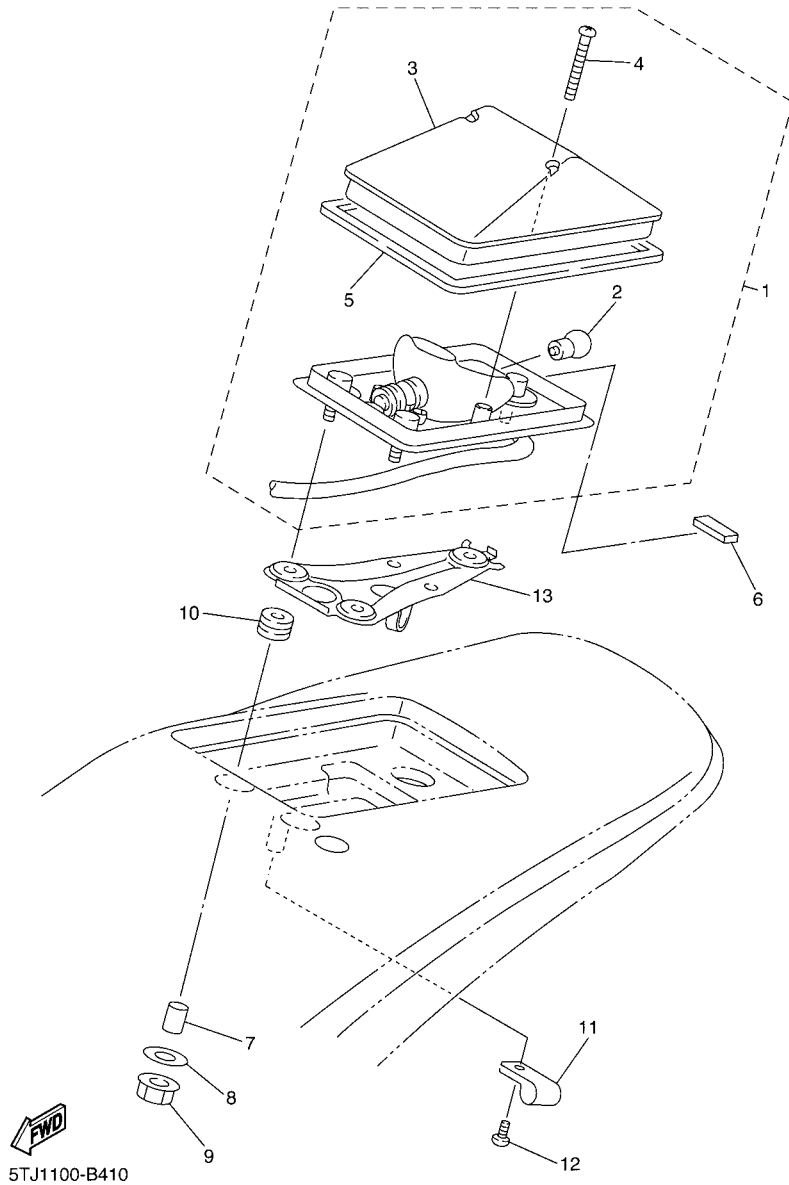


5TJ8100-D410

FIG. 41 HEADLIGHT

REF. NO.	PART NO.	DESCRIPTION	5TJ8	5TJ9	5TJA	REMARKS
1	5BF-84310-01	HEADLIGHT UNIT ASSY	1	1	1	
2	8G9-84314-00	.BULB (12V-60/55W)	1	1	1	(H4)HALOGEN
3	5BF-84397-00	.COVER, SOCKET	1	1	1	
4	5BF-84330-01	BODY ASSY	1	1	1	
5	55U-84337-00	BOLT, SPECIAL	2	2	2	
6	5BF-8433E-00	SCREW, ADJUSTING	1	1	1	
7	5BF-84335-00	SPRING	1	1	1	
8	5BF-84334-00	NUT, ADJUSTING	1	1	1	
9	5PH-84319-50	STAY, HEADLIGHT 2	1	1	1	
10	95027-08012	BOLT, FLANGE	2	2	2	
11	90105-06055	BOLT, FLANGE	3	3	3	
12	5BF-2339E-00	GRAPHIC 1	1	1	1	

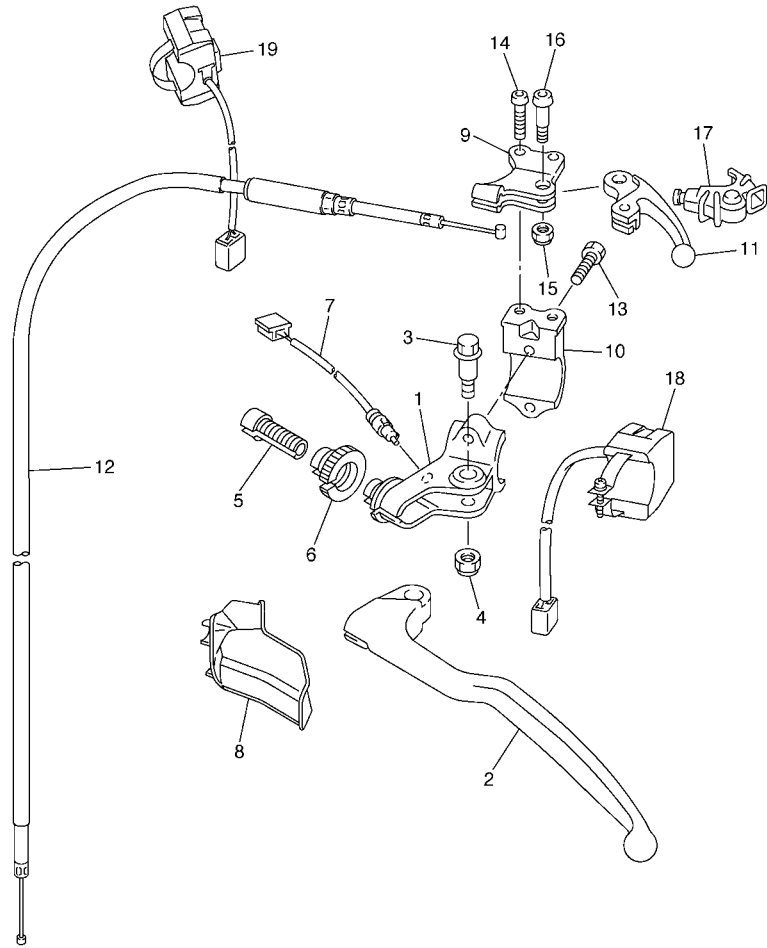




5TJ1100-B410

FIG. 42 TAILLIGHT

REF. NO.	PART NO.	DESCRIPTION	5TJ8	5TJ9	5TJA	REMARKS
1	5TJ-84710-00	TAILLIGHT UNIT ASSY	1	1	1	
2	36Y-84714-40	.BULB, TAILLIGHT (12V-21/5W)	1	1	1	
3	4GY-84733-00	.LENS, TAILLIGHT	1	1	1	
4	97706-40530	.SCREW, TAPPING	2	2	2	
5	4GY-84723-00	.GASKET, TAIL LENS	1	1	1	
6	1HX-27415-00	PLATE, DAMPER	1	1	1	
7	90387-065L5	COLLAR	3	3	3	
8	90201-06057	WASHER, PLATE	3	3	3	
9	95707-06500	NUT, FLANGE	3	3	3	
10	90480-14102	GROMMET	3	3	3	
11	90461-11099	CLAMP	2	2	2	
12	97780-40010	SCREW, TAPPING	2	2	2	
13	5TJ-21677-00	PLATE, FITTING 3	1	1	1	



**FIG. 43 HANDLE SWITCH & LEVER**

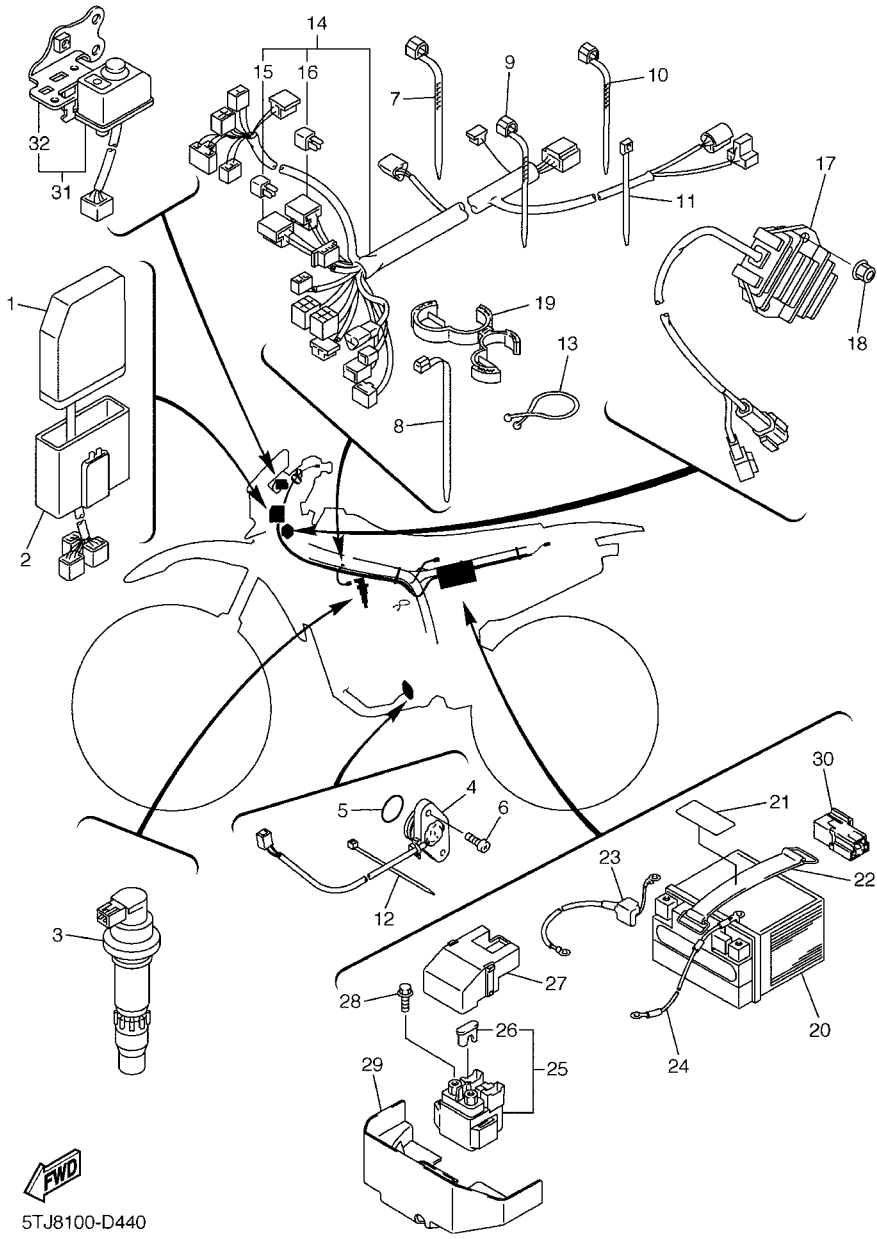
REF. NO.	PART NO.	DESCRIPTION	5TJ8	5TJ9	5TJA	REMARKS
1	5TJ-82911-80	HOLDER, LEVER 1	1	1	1	
2	5TJ-83912-80	LEVER 1	1	1	1	
3	90109-06034	BOLT	1	1	1	
4	5LP-84126-10	NUT, LENS FITTING	1	1	1	
5	5HD-26337-00	BOLT, ADJUSTING	1	1	1	
6	5HD-83951-00	BOLT, CABLE ADJUSTING	1	1	1	
7	5TJ-82917-01	SWITCH	1	1	1	
8	5TJ-26372-80	COVER, HANDLE LEVER 1	1	1	1	
9	5XD-82946-00	HOLDER, STARTER LEVER	1	1	1	
10	5XD-82913-00	HOLDER, LEVER LOWER 1	1	1	1	
11	5TA-83941-00	LEVER, STARTER	1	1	1	
12	5TA-26334-00	CABLE, STARTER 2	1	1	1	
13	90101-05033	BOLT	2	2	2	
14	92014-05012	BOLT, BUTTON HEAD	2	2	2	
15	95607-05100	NUT, U	1	1	1	
16	90149-05162	SCREW	1	1	1	
17	5TA-26339-00	BOOT	1	1	1	
18	5TJ-83976-01	SWITCH, HANDLE 1	1	1	1	
19	5TJ-83976-11	SWITCH, HANDLE 1	1	1	1	



5TJ5100-C420

FIG. 44 ELECTRICAL 1

REF. NO.	PART NO.	DESCRIPTION	5TJ8	5TJ9	5TJA	REMARKS
1	5TJ-85540-80	C.D.I. UNIT ASSY	1			
	5TJ-85540-90	C.D.I. UNIT ASSY		1	1	
2	5TJ-85546-00	BAND	1	1	1	
3	5TA-82310-10	IGNITION COIL ASSY	1	1	1	
4	5TJ-82540-01	NEUTRAL SWITCH ASSY	1	1	1	
5	93210-21276	O-RING	1	1	1	
6	90154-05026	SCREW, BINDING	2	2	2	
7	90464-13077	CLAMP	4	4	4	
8	90465-13275	CLAMP	5	5	5	
9	90464-13073	CLAMP	5	5	5	
10	90464-15195	CLAMP	1	1	1	
11	90465-13152	CLAMP	4	4	4	
12	5Y9-12491-00	CLAMP 1	4	4	4	
13	90464-23041	CLAMP	1	1	1	
14	5TJ-82590-80	WIRE HARNESS ASSY	1			
	5TJ-82590-90	WIRE HARNESS ASSY		1	1	
15	5TJ-81980-00	.DIODE ASSY	1	1	1	
16	4WA-81980-00	.DIODE ASSY	1	1	1	
17	5TJ-81960-80	RECTIFIER & REGULATOR ASSY	1	1	1	
18	95707-06500	NUT, FLANGE	2	2	2	
19	90464-29223	CLAMP	1	1	1	
20	5TJ-82100-00	BATTERY ASSY (YTZ7S)	1	1	1	
21	1JK-21268-00	SEAL	1	1	1	
22	8CY-82131-00	BAND, BATTERY	1	1	1	
23	5TJ-82115-00	WIRE, PLUS LEAD	1	1	1	
24	5TJ-82116-00	WIRE, MINUS LEAD	1	1	1	
25	5TJ-81940-11	STARTER RELAY ASSY	1	1	1	



**FWD**  
5TJ8100-D440



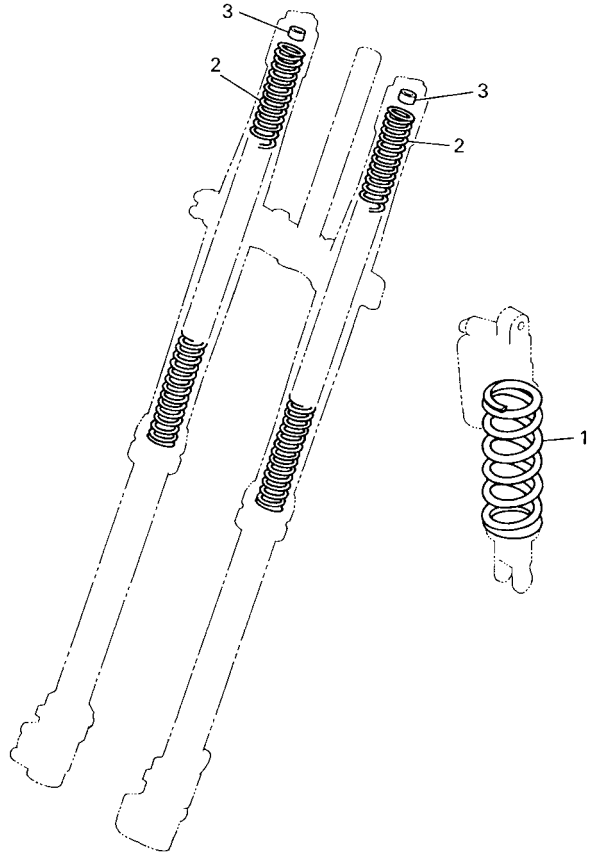


FIG. 45 ALTERNATE FOR CHASSIS

REF. NO.	PART NO.	DESCRIPTION	5TJ8	5TJ9	5TJA	REMARKS
1	5UN-22212-00	SPRING (K=42N/MM)	1	1	1	AP
	5UN-22212-10	SPRING (K=44N/MM)	1	1	1	AP
	5UN-22212-20	SPRING (K=46N/MM)	1	1	1	AP
	5UN-22212-40	SPRING (K=50N/MM)	1	1	1	AP
	5UN-22212-70	SPRING (K=56N/MM)	1	1	1	AP
2	5TJ-23141-00	SPRING (K=4.0N/MM)	2	2	2	AP
	5TJ-23141-10	SPRING (K=4.1N/MM)	2	2	2	AP
	5TJ-23141-30	SPRING (K=4.3N/MM)	2	2	2	AP
	5TJ-23141-60	SPRING (K=4.6N/MM)	2	2	2	AP
3	5XE-23364-00	COLLAR 2	2	2	2	UN AP



5BE100-8390

NUMERICAL INDEX

PART NO.	GRID NO.	PART NO.	GRID NO.	PART NO.	GRID NO.	PART NO.	GRID NO.	PART NO.	GRID NO.	PART NO.	GRID NO.
5TJ-11101-00	B - 2	3LD-12168-U1	B - 5	5BE-13447-10	B - 11	5NY-14442-00	B - 12	5JG-14922-00	C - 2	3Y1-15363-00	C - 7
4KG-1111G-00	B - 2	3LD-12168-W1	B - 5	5TA-13464-00	B - 10	5TA-14451-00	B - 12	5GS-14933-00	C - 3	4JT-15381-01	C - 6
5TA-11133-10	B - 2	3LD-12168-Y1	B - 5	5TA-13465-00	B - 10	5TJ-14453-00	B - 12	5GS-14933-40	C - 2	5BE-15383-01	C - 6
5TA-11134-10	B - 2	3LD-12169-11	B - 5	5TJ-13542-00	C - 4	5NY-14455-10	B - 12	5TA-14934-00	C - 2	5TJ-15411-10	C - 7
5TJ-11166-00	B - 3	3LD-12169-31	B - 6	5XD-13597-10	B - 12	5TJ-14457-00	B - 13	5GS-14940-00	C - 3	5TA-15415-10	C - 7
5BE-11167-00	B - 2	3LD-12169-50	B - 6	5TJ-14101-80	B - 14	5TJ-14458-00	B - 12	5JG-14940-17	C - 2	5TA-15421-00	C - 6
371-11167-01	B - 2	3LD-12169-70	B - 6	5NL-14105-00	B - 15	5TJ-14459-00	B - 12	5JG-14940-18	C - 2	5XD-15431-00	C - 7
5TA-11181-00	B - 2	3LD-12169-90	B - 6	4MX-14115-00	C - 3	5TJ-14462-00	B - 13	5JG-14940-19	C - 2	5TA-15441-01	C - 6
5TG-11190-10	B - 2	3LD-12169-E0	B - 6	3TJ-14137-40	B - 12	5TJ-14475-00	B - 12	5TA-14943-19	B - 15	5TJ-15451-00	C - 7
5TA-11193-00	B - 2	3LD-12169-G0	B - 6		C - 3	5JG-14521-00	B - 14	4MX-14943-38	B - 14	5TA-15453-00	C - 8
5TA-11311-01	B - 3	3LD-12169-J0	B - 6	5BE-14146-00	C - 3	5JG-14522-00	B - 14	4MX-14943-39	B - 15	5TA-15462-00	C - 7
5TA-11351-00	B - 3	3LD-12169-L0	B - 6	5PA-14146-00	C - 3	5JG-14531-00	C - 3	4MX-14943-40	B - 14	5TJ-1549B-10	C - 7
5TJ-11400-10	B - 4	3LD-12169-N0	B - 6	5TA-14155-00	C - 2	3TJ-14536-40	C - 2	4MX-14943-41	B - 15	5TG-15515-01	C - 10
5TJ-11412-10	B - 4	3LD-12169-T0	B - 6	633-14159-00	C - 2	5JG-14546-01	B - 14	4MX-14943-42	B - 15	5TJ-15517-00	C - 10
5TA-11422-00	B - 4	5TA-12170-00	B - 7	3TJ-14159-40	B - 14	676-14548-00	C - 2	4MX-14943-89	B - 15	4GY-15521-00	C - 10
5BE-11454-00	B - 4	5TJ-12180-00	B - 7	5TA-14171-00	C - 2	4MX-14561-00	C - 2	4MX-14943-90	B - 15	5TJ-15560-00	C - 10
5TA-11455-11	B - 4	5TA-12210-00	B - 7	3TJ-14191-40	C - 2	6H4-14561-00	C - 2	4MX-14943-91	B - 15	5TJ-15590-00	C - 10
5TA-11531-01	B - 4	4FM-12213-00	B - 7	5TA-14196-00	C - 3	5NX-14562-00	C - 2	4MX-14943-92	B - 15	5XD-15601-00	C - 9
5TA-11536-00	B - 4	5BE-12241-00	B - 2	5TA-14197-00	C - 3	5JG-14565-00	C - 3	5TJ-14947-00	B - 14	5XD-15620-00	C - 9
5JG-11603-00	B - 4	5TA-12251-01	B - 7	5NX-14216-00	C - 2	5TJ-14591-10	C - 3	4MX-14948-03	B - 15	5XD-15621-00	C - 9
5TJ-11631-00	B - 4	5TA-12252-00	B - 7	5TA-14227-00	B - 12	688-14592-00	B - 14	4MX-14948-04	B - 15	5TA-15651-00	C - 9
5TA-11633-00	B - 4	5TG-12299-00	B - 7	5TA-14239-00	B - 12	5TJ-14611-00	C - 5	4MX-14948-05	B - 15	5GR-15664-00	C - 9
5XD-11651-00	B - 4	5TA-1240A-00	B - 9	5TA-14261-00	C - 3	3VD-14613-01	C - 5	4MX-14948-06	B - 15	5SG-15668-00	C - 9
5TA-11681-00	B - 4	5BE-12422-20	B - 8	5JG-14264-00	B - 14	5TJ-14623-00	C - 5	4MX-14948-07	B - 15	4GY-15671-00	C - 9
5TA-12111-00	B - 5	5BE-12439-00	B - 8	3TJ-14267-40	B - 14	5TA-14628-00	C - 5	4JT-1494F-01	B - 15	214-15686-00	C - 9
5TA-12112-00	B - 5	5DJ-12451-00	B - 8	5JG-14275-00	B - 14	5TJ-14710-80	C - 5	4JT-1494F-03	B - 15	5TJ-16111-00	C - 11
5TA-12113-00	B - 5	5GR-12458-00	B - 8	5TA-14293-00	B - 12	5XD-14714-00	C - 5	4JT-1494F-05	B - 15	5XD-16150-20	C - 11
5TA-12114-00	B - 5	5TA-12461-00	B - 9	3TJ-14293-40	C - 2	4KM-14714-01	C - 4	4JT-1494F-07	B - 15	5XD-16154-00	C - 11
4GY-12117-00	B - 5	5HD-12462-00	B - 9	5TA-14335-00	C - 2	5BE-14747-00	C - 5	4JT-1494F-09	B - 15	5TA-16321-00	C - 11
5BE-12117-00	B - 5	5TA-12481-00	B - 9	5JG-14346-00	C - 3	4BD-14766-00	C - 5	3TJ-1494F-11	B - 15	1TA-16325-00	C - 11
1AA-12118-00	B - 5	5TA-12482-00	B - 9	5TA-14371-00	C - 2	5TJ-14780-00	C - 5	4JT-1494F-11	B - 15	4X7-16325-00	C - 11
1WG-12118-00	B - 5	5Y9-12491-00	F - 5	5TA-14374-00	C - 2	5TJ-14784-00	C - 5	3TJ-1494F-12	B - 15	5JG-16351-00	C - 11
33M-12119-00	B - 5	5BE-12564-00	B - 8	5JG-14379-00	C - 2	5BE-14788-00	C - 5	3TJ-1494F-13	B - 15	5JG-16356-00	C - 11
4SV-12119-00	B - 5	5TA-12576-00	B - 9	5JG-14388-00	B - 14	5TJ-14799-00	C - 5	4JT-1494F-13	B - 15	5TA-16357-10	C - 11
5TA-12121-00	B - 5	5TA-12578-00	B - 9	4MX-14392-00	C - 2	5TJ-14803-00	C - 4	3TJ-1494F-14	B - 15	5TA-16371-10	C - 11
3GM-12126-00	B - 5	5SG-12579-00	B - 9	5TJ-14401-20	B - 12	5TJ-1482K-00	C - 4	3TJ-1494F-15	B - 15	5TJ-16381-10	C - 11
3FV-12153-10	B - 6	5TA-12579-00	B - 9	5TJ-14419-00	B - 13	5TJ-14834-00	C - 4	5JG-14951-00	B - 14	5TA-16384-01	C - 11
3LD-12168-00	B - 5	583-13113-00	C - 8	5TJ-1441A-00	B - 13	5TJ-14871-00	C - 4	5GS-14958-00	C - 3	5BF-17121-00	C - 12
3LD-12168-20	B - 5	353-13115-01	B - 2	5TJ-1441E-10	B - 12	5TJ-14881-00	C - 4	5JG-14959-00	B - 14	5TJ-17131-00	C - 12
3LD-12168-40	B - 5	5TG-13161-00	B - 11	5TJ-1441G-00	B - 12	5TJ-14882-00	C - 4	5JG-14984-00	C - 2	5TJ-17141-10	C - 12
3LD-12168-60	B - 5	5TA-13171-00	B - 11	5TJ-14425-10	B - 12	5TJ-14916-91	B - 14	4SR-14985-00	B - 15	5TJ-17151-00	C - 12
3LD-12168-80	B - 5	5TA-13300-00	B - 10	5TJ-14426-00	B - 12	5TA-14916-9P	B - 14	5TA-14987-00	B - 12	5BF-17211-00	C - 12
3LD-12168-A0	B - 5	5TA-13320-00	B - 10	5TA-14428-00	B - 12	5TJ-14916-9R	B - 14	5TJ-14987-00	C - 3	5TJ-17221-00	C - 12
3LD-12168-F0	B - 5	5TA-13341-00	B - 10	5TJ-1442A-00	B - 13	5TJ-14916-9S	B - 14	5TA-14991-00	C - 2	5TJ-17231-10	C - 12
3LD-12168-H1	B - 5	5BE-13342-00	B - 10	5TJ-14436-00	B - 12	5TJ-14916-9T	B - 14	4FN-14997-00	B - 14	5TJ-17241-10	C - 12
3LD-12168-K1	B - 5	5BE-13411-00	B - 10	5TJ-14437-10	B - 12	5TA-14916-9U	B - 14	5TA-14997-00	C - 2	5BF-17251-00	C - 12
3LD-12168-M1	B - 5	5TA-13412-00	B - 10	5TJ-1443A-00	B - 13	5TJ-14916-9V	B - 14	5TJ-15150-10	C - 6	5BE-17402-00	C - 12
3LD-12168-R1	B - 5	5TA-13440-00	B - 11	5BF-1443E-00	B - 13	5TJ-14916-NT	B - 14	5TA-15362-01	D - 3	5TJ-17411-10	C - 12

NUMERICAL INDEX

PART NO.	GRID NO.	PART NO.	GRID NO.	PART NO.	GRID NO.	PART NO.	GRID NO.	PART NO.	GRID NO.	PART NO.	GRID NO.
5NG-17460-00	C - 13	5XD-2173E-10	D - 5	5XE-22242-00	D - 9	5TJ-23170-90	D - 11	5ET-25317-00	E - 5	3JD-25917-00	E - 4
5TA-17466-00	C - 6	5XD-2173F-10	D - 5	1C3-22253-00	D - 8	5XE-23171-L0	D - 11	4XM-25364-00	E - 5		E - 7
4L0-17471-00	C - 6	5TA-21740-00	D - 5	5MV-22253-00	D - 8	5BF-2317M-00	E - 15	5TJ-25367-80	E - 6	5DH-25919-00	E - 4
5GR-17471-00	C - 13	5TJ-2174A-00	D - 5	4AA-22259-40	D - 8	5DH-23183-00	D - 8	1C3-25381-00	E - 6	5DH-25919-50	E - 7
5TJ-18101-00	C - 15	5TA-2174T-00	D - 4	4AA-22259-60	D - 8	509-23184-L0	D - 8	5TJ-25383-80	E - 6	8CR-25924-00	E - 7
5UL-18110-00	C - 15	5TA-21756-00	D - 2	4AA-22259-80	D - 8	5MV-23195-L0	D - 11	1C3-25388-00	E - 6	3SP-25926-51	E - 4
5MW-18122-01	C - 15	2TK-21757-00	B - 13	1P8-22355-00	D - 6	5TJ-2319U-00	D - 10	1C3-25389-00	E - 6	5DH-25933-00	E - 4
3XK-18140-00	C - 14	5TJ-21757-00	B - 13	4EW-22474-00	D - 8	5TJ-2331E-80	D - 10	3JE-25394-00	E - 5	1UY-25937-51	E - 4
5TJ-18172-00	C - 15	5MV-2175C-00	D - 5	3JE-22475-00	D - 8	5TJ-23340-L0	D - 13	5SF-25394-00	E - 3		E - 7
3XJ-18173-10	C - 15	4XV-2177L-01	B - 12	5NY-22475-00	D - 8	5NY-23346-L0	D - 13	1C3-25448-00	E - 5	1C3-26111-00	E - 8
3XJ-18178-00	C - 15	5GS-21871-00	D - 5	5UN-22898-60	E - 7	3SP-23356-L0	D - 13	5GS-25448-50	E - 5	1C3-26124-00	E - 8
3XJ-18182-00	C - 15	26H-21874-00	D - 5	1C3-22969-10	D - 6	5XE-23364-00	F - 7	1C3-25449-00	E - 5	5BE-26240-00	E - 8
3XJ-18184-00	C - 15	26H-21875-00	D - 5	5TJ-23102-90	D - 11	5TJ-23389-80	D - 10	1C3-25450-00	E - 5	4GY-26241-00	E - 8
4EW-18185-00	C - 15	1C3-22110-00	D - 6	5TJ-23102-A0	D - 11	5HD-23393-L0	D - 11	5TJ-25450-80	E - 5	4GY-26242-00	E - 8
5BE-18501-00	C - 14	5XD-22121-50	D - 7	5TJ-23102-L0	D - 11	5BF-2339E-00	F - 2	1C3-25451-00	E - 5	3Y1-26249-00	E - 8
5BE-18502-00	C - 14	1C3-22122-00	D - 7	5TJ-23103-90	D - 12	4EW-23416-00	D - 10	1C3-25452-00	E - 5	5BE-26281-00	E - 8
5BE-18503-00	C - 14	5UN-22128-00	D - 6	5TJ-23103-A0	D - 12	5TJ-23103-80	D - 10	5TJ-25452-80	E - 5	5BE-26282-00	E - 8
5NL-18541-00	C - 14	5XD-22141-50	D - 6	5TJ-23103-L0	D - 12	5XE-23441-00	D - 10	5CG-25715-00	E - 9	5SF-26287-00	E - 8
278-18542-00	C - 14	1C3-22151-00	D - 6	5TJ-23110-90	D - 12	1C3-23466-00	D - 13		E - 12	5XD-26302-00	E - 8
5DH-18562-00	C - 6	5UN-22176-00	D - 8	5TJ-23110-L0	D - 12	1C3-23467-00	D - 13	5DH-25718-01	E - 7	5TA-26334-00	F - 4
5TJ-21101-80	D - 2	4EW-22178-01	D - 2	5XE-23111-L0	D - 11	5TJ-24110-80	D - 14	1C3-2580T-00	E - 4	5TJ-26335-80	E - 8
5TA-21161-00	D - 2	3JD-22178-20	D - 2	5XE-23113-00	D - 10	4EW-2412F-00	D - 14	1C3-2580W-00	E - 7	5HD-26337-00	F - 4
5TJ-21190-80	D - 2	1C3-2217A-00	D - 6	5TJ-23118-L0	D - 11	5XE-24144-00	D - 14	5MV-2581T-00	E - 4	5TA-26339-00	F - 4
1JK-21268-00	F - 5	1C3-2217F-00	D - 6	5TJ-23120-90	D - 11	5SF-24173-00	D - 14	5HD-26342-60	E - 7	5HD-26342-00	E - 8
5TJ-21335-00	D - 2	5MV-22184-00	D - 8	5TJ-23120-L0	D - 11	5XE-24176-00	D - 14	5UN-25828-60	E - 7	5NY-26372-00	E - 9
1C3-2135F-00	D - 7	5UN-22199-00	D - 6	5XE-23125-L0	D - 11	22W-24181-00	C - 5	5NY-2582W-00	E - 7	5TJ-26372-80	F - 4
1C3-2139R-00	D - 7	5TJ-22201-90	D - 8	5TJ-23136-L0	D - 11	5TJ-24181-00	D - 14	5MV-25833-00	E - 9	5TA-27200-00	E - 10
5XD-21417-50	D - 3	5TJ-22201-A0	D - 8	5TJ-23141-00	F - 7	5BE-24182-00	D - 14	5UN-2583V-00	E - 12	1C3-27217-00	E - 10
5XD-21425-00	D - 2	5TJ-22201-L0	D - 8	5TJ-23141-10	F - 7	5NY-24183-00	D - 14	5DH-25849-00	E - 4	5UN-27217-00	E - 12
5XD-21425-10	D - 2	5TJ-22201-M0	D - 8	5TJ-23141-30	F - 7	5NY-24186-00	D - 14	5MV-25852-01	E - 9	5UN-27218-00	E - 12
5TJ-21458-50	E - 10	5TJ-22210-90	D - 8	5TJ-23141-60	F - 7	5TJ-24240-20	D - 15	5UN-25852-50	E - 12	5UN-27222-00	E - 12
5TA-21471-00	D - 3	5TJ-22210-A0	D - 8	5TJ-23141-90	D - 11	3XJ-24380-00	D - 14	5XE-25853-00	E - 9	5TJ-27311-80	E - 10
5TA-2147A-00	D - 3	5TJ-22210-L0	D - 8	5TJ-23141-A0	D - 11	2GU-24500-02	D - 14	5UN-25854-00	E - 12	5TJ-27314-50	E - 10
5TA-2147E-00	D - 3	5TJ-22210-M0	D - 8	5TJ-23141-L0	D - 11	4X8-24512-00	D - 14	5XE-25854-00	E - 9	5ET-27411-00	E - 10
5TJ-2147F-00	D - 3	5UN-22212-00	F - 7	5TJ-23142-L0	D - 11	3AC-24523-00	D - 14	5UN-2585B-00	E - 12	5TJ-27414-80	E - 10
5HD-21511-00	D - 4	5UN-22212-10	F - 7	5XE-23144-L0	D - 11	3AJ-24534-01	D - 14	5MV-25867-00	E - 9	1HX-27415-00	F - 3
5UN-2153A-00	D - 7	5UN-22212-20	F - 7	1C3-23145-L0	D - 11	5NY-24610-00	D - 14	5NY-25868-00	E - 9	5ET-27421-00	E - 10
4XL-2153A-10	D - 13	5UN-22212-30	D - 8	5XE-23146-L0	D - 11	5TJ-2470F-80	E - 2	5TJ-25872-80	E - 9	5TA-27491-00	E - 7
4ES-2153E-01	D - 4	5UN-22212-40	F - 7	5TJ-23149-L0	D - 11	5UN-24710-80	E - 2	5UN-25873-00	E - 12	5TA-2814F-00	D - 3
5TJ-21610-80	D - 4	5UN-22212-50	D - 8	1C3-2314F-L0	D - 12	5NY-25104-00	E - 3	1C3-25875-00	E - 4	5ET-28166-00	D - 3
5XD-21635-00	D - 4	5UN-22212-60	D - 8	5XE-23153-L0	D - 11	5NG-25111-50	E - 3	1C3-25876-00	E - 12	5TJ-2831V-80	D - 10
5TJ-2163G-10	D - 4	5UN-22212-70	F - 7	3JD-23158-L0	D - 11	5NY-25117-00	E - 3	2VW-25876-00	E - 12	3FV-28386-00	B - 13
5TA-21642-00	D - 4	3SP-22213-00	D - 8	1C3-2315H-00	D - 13	5TJ-25118-80	E - 3	5MV-2589F-00	E - 9	5TJ-81410-10	E - 13
5TJ-21677-00	F - 3	5XE-22214-00	D - 9	5TJ-2315J-80	D - 13	1C3-25181-00	E - 3	5UN-25914-00	E - 7	5TJ-81450-20	E - 13
5TJ-21711-80	D - 5	5MV-22224-00	D - 8	5TJ-2316A-80	D - 11	5TJ-25183-80	E - 3	5DH-25914-50	E - 7	5TJ-81801-00	E - 14
5TJ-21721-00	D - 5	4JX-22226-00	D - 8	5TJ-2316A-90	D - 11	5NG-25190-50	E - 3	3SP-25914-51	E - 4	5TJ-81828-00	E - 14
5TA-2172A-00	D - 5	3SP-22234-00	D - 8	5TJ-2316A-A0	D - 11	5GS-25304-00	E - 5	5DH-25916-00	E - 4	5TJ-8183G-00	E - 14
5TA-21730-00	D - 5	5NY-22241-00	D - 9	5TJ-23170-80	D - 11	5ET-25311-00	E - 5		E - 7	50W-81846-M0	E - 14

NUMERICAL INDEX

PART NO.	GRID NO.	PART NO.	GRID NO.	PART NO.	GRID NO.	PART NO.	GRID NO.	PART NO.	GRID NO.	PART NO.	GRID NO.
5TJ-81890-10	E - 14	55U-84337-00	F - 2	90110-06004	C - 10	90201-08089	E - 10	90387-06065	B - 9	90465-13152	D - 14
5TJ-81940-11	F - 5	5BF-8433E-00	F - 2	90110-06058	B - 10	90201-08326	E - 5	90387-06090	D - 4		F - 5
8DM-81950-00	F - 6	5BF-84397-00	F - 2	90110-06110	E - 13	90201-08410	C - 2	90387-065L5	F - 3	90465-13275	F - 5
5TJ-81952-80	F - 6	5TJ-84710-00	F - 3	90110-08035	C - 9	90201-08512	B - 8	90387-06M24	E - 10	90467-07138	C - 4
5TJ-81953-00	B - 13	36Y-84714-40	F - 3	90111-06029	E - 12	90201-086P8	D - 3	90387-0814J	C - 5	90467-09006	C - 4
5TJ-81960-80	F - 5	4GY-84723-00	F - 3	90119-06001	D - 3		E - 10	90387-086N4	D - 2		D - 5
4WA-81980-00	F - 5	4GY-84733-00	F - 3	90119-06051	D - 5	90201-087A9	C - 9	90387-1003G	E - 10	90467-10008	D - 14
5TJ-81980-00	F - 5	5TJ-85540-80	F - 5	90119-06096	D - 4	90201-10025	B - 2	90387-124F4	C - 15	90467-11106	B - 2
5TJ-82100-00	F - 5	5TJ-85540-90	F - 5	90119-06192	D - 4	90201-10118	E - 9	90387-14006	D - 7	90467-14015	B - 3
5TJ-82115-00	F - 5	5TJ-85546-00	F - 5	90119-06225	D - 4		E - 12	90387-16010	D - 6	90467-15054	C - 4
5TJ-82116-00	F - 5	5TA-85885-00	C - 2	90119-08238	D - 5	90201-10119	E - 10	90387-18004	D - 6	90467-15197	C - 4
5SL-82119-10	F - 6	5NY-W0041-00	E - 9	90149-05162	F - 4	90201-104R2	D - 2	90387-18007	C - 6	90467-17089	B - 13
8CY-82131-00	F - 5	5UN-W0042-50	E - 12	90149-05283	E - 13	90201-105A8	C - 10	90387-18009	D - 6	90468-08104	B - 3
42X-82151-00	F - 6	5MV-W0045-01	E - 4	90149-06011	D - 14	90201-12020	E - 13	90387-2113G	C - 12		C - 4
5TA-82310-10	F - 5	1C3-W0046-00	E - 7	90149-06126	C - 6	90201-12166	B - 10	90387-2513F	C - 12	90468-16099	E - 10
5TJ-82510-80	F - 6	3JD-W0047-00	E - 4	90149-06250	B - 4	90201-125L6	C - 11	90401-08038	B - 11	90480-01512	D - 4
5TJ-82514-80	F - 6	5UN-W0047-50	E - 7	90149-06326	C - 6	90201-145M4	D - 2	90401-10159	B - 11	90480-14102	F - 3
5TJ-82540-01	F - 5	1UY-W0048-50	E - 4	90149-06327	E - 4	90201-14740	D - 7	90401-10172	E - 9	90480-14532	D - 4
5TJ-82590-80	F - 5		E - 7	90151-04001	D - 6	90201-15701	C - 7		E - 12	90480-15528	B - 9
5TJ-82590-90	F - 5	5UN-W0057-00	E - 4	90152-06010	C - 9	90201-160F6	D - 6	90430-06014	B - 2	90480-18549	D - 14
5TJ-82911-80	F - 4	5UN-W0057-50	E - 7	90154-05026	F - 5	90201-162H4	C - 9		B - 8	90501-043E0	C - 8
5XD-82913-00	F - 4	5XE-W2587-00	E - 9	90157-02031	E - 15	90201-167P7	C - 9		C - 6	90501-052G5	C - 15
5TJ-82917-01	F - 4	90101-05033	F - 4	90159-06078	D - 5	90201-20276	C - 9	90430-08119	B - 11	90501-06022	C - 14
5XD-82946-00	F - 4	90101-06001	C - 9	90159-06092	C - 11	90201-203U1	E - 6		D - 2	90501-147A5	C - 9
5TJ-8350E-80	D - 10	90101-06034	C - 15	90170-14171	B - 4	90201-20685	C - 9	90430-10188	B - 11	90501-16016	C - 9
4V5-83513-00	E - 15	90101-08777	E - 6	90170-20327	C - 11	90201-21013	D - 6		C - 6	90501-237L0	C - 11
5TJ-83513-80	E - 15	90105-05361	D - 10	90170-24373	D - 10	90201-247L2	D - 10	90445-09100	D - 14	90506-16500	E - 10
5NG-83519-00	E - 15	90105-06027	B - 2	90179-06500	B - 3	90201-253K0	C - 12	90445-09220	D - 14	90506-30002	E - 10
437-83525-00	E - 15	90105-06055	D - 5	90179-06568	D - 6	90201-286K9	D - 10	90445-11185	D - 14	90508-14020	C - 11
1M1-83526-00	E - 15		F - 2	90179-08299	E - 6	90202-05193	D - 14	90445-112K0	B - 2	90508-26561	C - 14
5BF-83550-00	E - 15	90105-06553	C - 6	90179-10658	D - 2	90202-08045	B - 14	90450-20078	C - 4	90508-282B8	E - 10
5TJ-8355W-00	E - 15		C - 13	90179-12657	E - 13	90206-06090	C - 5	90450-22017	B - 9	90508-282B9	E - 10
5TJ-8355W-10	E - 15	90105-08057	C - 5	90179-16002	E - 3	90208-25045	C - 11		B - 10	90508-291A8	C - 15
1AE-83578-00	E - 15		D - 2	90179-20001	C - 13	90209-16008	D - 6	90450-25037	B - 9	90508-305B0	C - 9
2HR-83592-00	E - 15	90105-08120	D - 2	90179-20009	C - 11	90209-21332	C - 12	90450-28014	B - 9	91314-05008	C - 5
5TJ-83912-80	F - 4	90105-08659	C - 5	90179-28650	D - 10	90209-26348	C - 12	90450-57009	B - 12	91314-06030	B - 10
5MV-83922-00	E - 9		E - 4	90183-06023	B - 13	90215-14287	B - 4	90450-59002	B - 12	91316-04012	B - 14
5TA-83941-00	F - 4	90105-10099	D - 2	90185-08055	E - 10	90215-20005	C - 11	90450-61001	B - 12	91317-05012	C - 7
5HD-83951-00	F - 4	90105-104A7	B - 2	90185-08169	E - 5	90215-21003	C - 13	90461-10136	C - 6	91317-06012	B - 9
5TJ-83976-01	F - 4	90105-106A3	B - 2	90185-10060	D - 9	90240-08120	E - 10	90461-11099	F - 3	91317-06020	B - 11
5TJ-83976-11	F - 4	90105-10733	D - 2	90185-14007	D - 7	90240-10142	E - 10	90464-13073	F - 5	91317-06050	C - 6
5LP-84126-10	F - 4	90109-06034	F - 4	90185-16127	D - 6	90267-32146	B - 12	90464-13077	F - 5	91317-06060	C - 6
5BF-84310-01	F - 2	90109-063F8	C - 14	90185-20168	E - 6	90280-03006	B - 4	90464-15195	F - 5	91317-06065	B - 11
8G9-84314-00	F - 2	90109-065G2	B - 11	90201-05033	E - 15	90338-18176	D - 3	90464-23041	C - 4	91317-06075	C - 6
5PH-84319-50	F - 2	90109-065G4	E - 7	90201-06057	F - 3	90340-12112	B - 2		F - 5	91317-08020	C - 5
5BF-84330-01	F - 2	90109-066F0	B - 2	90201-06557	D - 4	90340-14128	C - 7	90464-25267	B - 3	91401-20012	E - 10
5BF-84334-00	F - 2	90109-08051	E - 10	90201-06571	B - 9	90340-27002	C - 7	90464-29223	F - 5	91401-25015	E - 10
5BF-84335-00	F - 2	90109-081G1	E - 5	90201-08008	C - 5	90387-06009	D - 4	90465-10017	C - 7	91808-16023	B - 2



NUMERICAL INDEX

PART NO.	GRID NO.	PART NO.	GRID NO.	PART NO.	GRID NO.	PART NO.	GRID NO.	PART NO.	GRID NO.	PART NO.	GRID NO.
91812-16001	C - 7	93306-20532	C - 12	95024-06010	C - 6	95707-06500	F - 5				
91A11-05125	D - 5	93306-20593	C - 12	95027-06008	F - 6	95707-08500	B - 2				
91A20-05140	D - 5	93306-27205	E - 5	95027-06010	B - 2		D - 2				
92014-05008	C - 5	93306-30633	B - 4		C - 4	95807-06016	E - 11				
92014-05012	F - 4	93306-90403	E - 3		D - 6	95817-08016	D - 3				
92017-05008	E - 15	93306-90501	C - 14		E - 4	95817-10055	D - 2				
92017-10060	D - 2	93310-212R6	C - 10	95027-06012	B - 9	95827-06010	B - 9				
92990-10200	E - 10	93310-63417	B - 4		B - 11	95827-06016	B - 13				
93101-14164	C - 7	93311-62574	B - 4		C - 4		D - 5				
93102-12106	B - 8	93315-32165	D - 6		C - 11	95827-08012	D - 2				
93102-12224	C - 11	93315-32166	D - 6		D - 3	97602-04110	C - 3				
	C - 15	93317-11287	C - 11		E - 7	97706-40530	F - 3				
93102-20108	C - 9	93317-22262	D - 6		E - 15	97707-30512	B - 13				
93102-26468	E - 3	93332-00068	D - 10	95027-06016	C - 6	97707-40016	B - 12				
93102-32480	C - 12	93332-00081	D - 10		C - 7	97707-50516	B - 13				
93106-22019	D - 6	93340-21505	C - 11		D - 14	97707-60016	D - 4				
93106-30001	E - 5	93342-22217	D - 6		E - 7	97780-40010	F - 3				
93106-30045	E - 5	93410-20038	C - 9	95027-06020	B - 13	98502-04012	B - 14				
93109-11073	B - 8	93420-18082	B - 4		C - 4	98507-03008	D - 14				
93109-21001	D - 7	93440-10085	C - 11		C - 7	98507-05010	E - 12				
93109-25001	D - 6	93440-10153	B - 2		C - 15	98507-05020	E - 8				
93109-28043	D - 6		B - 10		D - 10	98507-06025	C - 6				
93210-07003	B - 11	93440-25084	C - 12	95027-06025	B - 7	98706-04012	E - 9				
93210-07135	B - 11	93440-28062	C - 12		B - 9	98707-06025	D - 14				
93210-08001	D - 3	93440-41178	B - 7		B - 10	98907-06025	D - 14				
93210-09008	B - 11	93503-08007	C - 8		E - 14	98980-06008	C - 5				
93210-10197	B - 10	93507-32009	C - 9	95027-06030	B - 8	99001-08600	B - 10				
	C - 6	93511-32027	C - 11		C - 7	99009-12400	B - 10				
93210-11073	E - 10	93603-16219	B - 10	95027-06035	B - 3	99009-16400	C - 9				
93210-12759	B - 11	93604-10011	B - 8	95027-06040	C - 7	99009-20400	C - 9				
93210-14369	C - 7	93608-33002	C - 15	95027-06050	D - 6	99009-22500	C - 7				
93210-16500	B - 9	93612-16254	B - 3	95027-06080	C - 8	99009-45500	E - 5				
93210-17570	C - 9	9383E-14215	C - 13	95027-08012	D - 3	99530-08012	B - 10				
93210-19123	C - 7	9383E-15082	C - 13		F - 2	99530-08016	C - 7				
93210-19758	B - 8	94108-21015	E - 3	95027-08035	D - 10	99530-10114	B - 10				
93210-21276	F - 5	94109-21009	E - 3	95027-08040	D - 2		C - 6				
93210-22164	C - 12	94111-18012	E - 5		D - 10	99530-10116	C - 6				
93210-25711	E - 14	94113-18015	E - 5		D - 13	99530-14016	C - 6				
93210-27370	C - 7	94212-18188	E - 5	95027-08065	D - 2	9Y58A-76113	E - 6				
93210-44678	E - 14	94213-18012	E - 5	95027-10016	C - 6						
93210-47675	B - 11	94227-21101	E - 3	95027-10020	E - 10						
93210-58346	C - 7	94309-18146	E - 5	95607-05100	F - 4						
93300-60804	D - 2	94309-21161	E - 3	95607-10200	D - 9						
93306-00105	B - 8	94416-21003	E - 3	95617-06635	B - 2						
93306-00426	C - 12	94421-18610	E - 5	95617-08620	B - 2						
93306-00431	C - 12	94591-57118	B - 7	95701-06500	E - 9						
93306-07202	E - 5	94681-76021	E - 6	95707-06500	D - 13						
93306-20335	B - 4	94701-00411	B - 2		F - 3						