



PARTS CATALOGUE

WR450FA (1HB2) CANADA

WR450F (1HB3) EUROPE

WR450FA (1HB4) OCEANIA, SOUTH AFRICA

1K1HB-100E1

()



2010-12-17

NEWS No.	DATE	COMMENT
PE0-MC-100026	Sep.,27,2010	MOD: FIG.4: CAMSHAFT & CHAIN LIST/ILLUSTRATION REVISION
PE0-MC-100034	Nov.,30,2010	MOD: FIG.23: SIDE COVER LIST/ILLUSTRATION REVISION

WR450FA/WR450F
PARTS CATALOGUE
©2010 by Yamaha Motor Co., Ltd.
1st edition, May 2010
All rights reserved.
Any reprinting or unauthorized use
without the written permission of
Yamaha Motor Co., Ltd.
is expressly prohibited.
Printed in Japan.

FOREWORD

This Parts Catalogue is related to the parts for the model(s) on the cover page. When you are ordering replacement parts, please refer to this Parts Catalogue and quote both part numbers and part names correctly.

1. Modifications or additions which have been made after the issue of the Parts Catalogue will be announced in the Parts News.

It is advisable that you make the necessary corrections to the Parts Catalogue according to the Parts News.

2. Abbreviations

The following abbreviations are used in this Parts Catalogue.

“UR” Use specified parts number.

“UN” Use as many as needed.

“AP” Alternate Parts

“LM” Locally Made (Parts need to be ordered locally)

“F#” Frame No. (Applicable machine No.)

“O/S” Over Size

3. The number of components for assembly

- Parts, which are to be supplied in an assembly, are listed with a dot (.) in front of the part name as shown below.
- The numeral appearing to the right of each component part indicates the quantity of parts for each assembly unit.

PART NO.	DESCRIPTION	Q'TY	REMARKS
2F5-83310-60	FRONT FLASHER LIGHT ASSY	2	
115-83311-60	.BULB (6V-18W)	1	

4. Applicable colours of graphics are represented in the “REMARKS” as shown below.

PART NO.	DESCRIPTION	Q'TY	REMARKS
2N4-24110-00-X5	FUEL TANK COMP.	2	MXR
3J1-24240-10	.GRAPHIC, FUEL TANK	1	FOR MXR

5. Note that the illustrations for reference in finding parts numbers are not to be used for assembling. When assembling, please use the applicable service manual.

6. The asterisk (*) before a reference number indicates modified items after the first edition.

CONTENTS

ENGINE

CYLINDER	1
CRANKSHAFT & PISTON	2
VALVE	3
CAMSHAFT & CHAIN	5
WATER PUMP	6
RADIATOR & HOSE	7
OIL PUMP	9
OIL CLEANER	10
INTAKE	11
CARBURETOR	13
AIR INDUCTION SYSTEM	18
EXHAUST	19
CRANKCASE	20
CRANKCASE COVER 1	22
STARTER	24
STARTER CLUTCH	25
CLUTCH	26
TRANSMISSION	27
SHIFT CAM & FORK	29
SHIFT SHAFT	30

CHASSIS

FRAME	31
FENDER	33
SIDE COVER	35
REAR ARM	37
REAR SUSPENSION	39
STEERING	41
FRONT FORK	42
FUEL TANK	45
SEAT	47
FRONT WHEEL	48
FRONT BRAKE CALIPER	49
REAR WHEEL	50
REAR BRAKE CALIPER	52
STEERING HANDLE & CABLE	53
FRONT MASTER CYLINDER	54
STAND & FOOTREST	55
REAR MASTER CYLINDER	56
GENERATOR	57
STARTING MOTOR	58

METER	59
HEADLIGHT	60
TAILLIGHT	61
HANDLE SWITCH & LEVER	62
ELECTRICAL 1	63
ALTERNATE FOR CHASSIS	65

INDEX

NUMERICAL INDEX	66
-----------------------	----

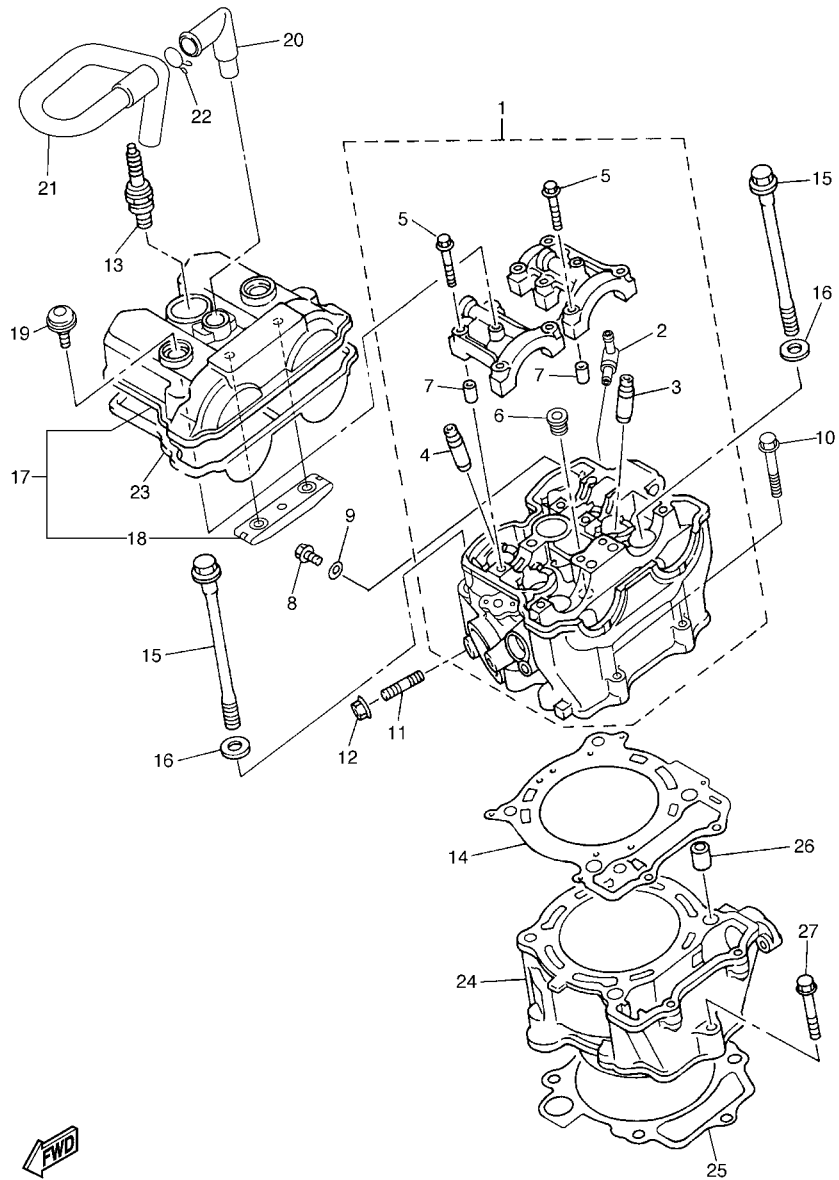

5TJE100-F010

FIG. 1 CYLINDER

REF. NO.	PART NO.	DESCRIPTION	1HB2	1HB3	1HB4	REMARKS
1	5TJ-11101-10	CYLINDER HEAD ASSY	1	1	1	
2	353-13115-01	.CONNECTOR, SUCTION PIPE	1	1	1	
3	5TA-11133-10	.GUIDE, VALVE 1	3	3	3	
4	5TA-11134-10	.GUIDE, VALVE 2	2	2	2	
5	90105-06027	.BOLT, FLANGE	10	10	10	
6	90340-12007	.PLUG, STRAIGHT SCREW	1	1	1	
7	91808-16023	.PIN, DOWEL	4	4	4	
8	95022-06010	BOLT, FLANGE	1	1	1	
9	90430-06014	GASKET	1	1	1	
10	95022-06035	BOLT, FLANGE	2	2	2	
11	90116-08022	BOLT, STUD	1	1	1	
12	95702-08500	NUT, FLANGE	1	1	1	
13	94701-00411	PLUG, SPARK (NGK R CR8E)	1	1	1	
14	2S2-11181-00	GASKET, CYLINDER HEAD 1	1	1	1	
15	90105-10163	BOLT, FLANGE	4	4	4	
16	90201-10025	WASHER, PLATE	4	4	4	
17	2S2-11190-20	COVER, CYLINDER HEAD 1	1	1	1	
18	5BE-12241-00	.GUIDE, STOPPER 2	1	1	1	
19	5UM-1119E-00	BOLT, COVER HEAD	2	2	2	
20	3P6-11167-00	PIPE, BREATHER 2	1	1	1	
21	5TJ-11166-10	PIPE, BREATHER 1	1	1	1	
22	90467-160A4	CLIP	1	1	1	
23	2S2-11193-00	GASKET, HEAD COVER 1	1	1	1	
24	2S2-11311-10	CYLINDER 1	1	1	1	
25	2S2-11351-00	GASKET, CYLINDER	1	1	1	
26	93612-16254	PIN, DOWEL	2	2	2	
27	95022-06035	BOLT, FLANGE	1	1	1	

FIG. 2 CRANKSHAFT & PISTON

REF. NO.	PART NO.	DESCRIPTION	1HB2	1HB3	1HB4	REMARKS
1	5TJ-11400-21	CRANKSHAFT ASSY	1	1	1	
2	5TJ-11412-20	.CRANK 1	1	1	1	
3	2S2-11422-00	.CRANK 2	1	1	1	
4	5TG-11681-01	.PIN, CRANK 1	1	1	1	
5	93310-63417	.BEARING	1	1	1	
6	2S2-11651-00	.ROD, CONNECTING	1	1	1	
7	93306-30633	BEARING	2	2	2	
8	2S2-11536-00	GEAR, DRIVE	1	1	1	
9	2S2-11455-00	SHAFT 1	1	1	1	
10	93304-20310	BEARING	2	2	2	
11	2S2-11531-00	GEAR, BALANCE WEIGHT	1	1	1	
12	90170-14171	NUT	1	1	1	
13	90215-14287	WASHER, LOCK	1	1	1	
14	2S2-11454-00	WEIGHT 1	1	1	1	
15	90149-06083	SCREW	3	3	3	
16	2S2-11464-00	WEIGHT 2	1	1	1	
17	90282-05034	KEY, STRAIGHT	1	1	1	
18	90170-10405	NUT	1	1	1	
19	90215-10009	WASHER, LOCK	1	1	1	
20	90280-03006	KEY, WOODRUFF	1	1	1	
21	2S2-11631-20	PISTON (STD)	1	1	1	
22	5JG-11603-00	PISTON RING SET (STD)	1	1	1	
23	5TA-11633-00	PIN, PISTON	1	1	1	
24	93420-18082	CIRCLIP	2	2	2	

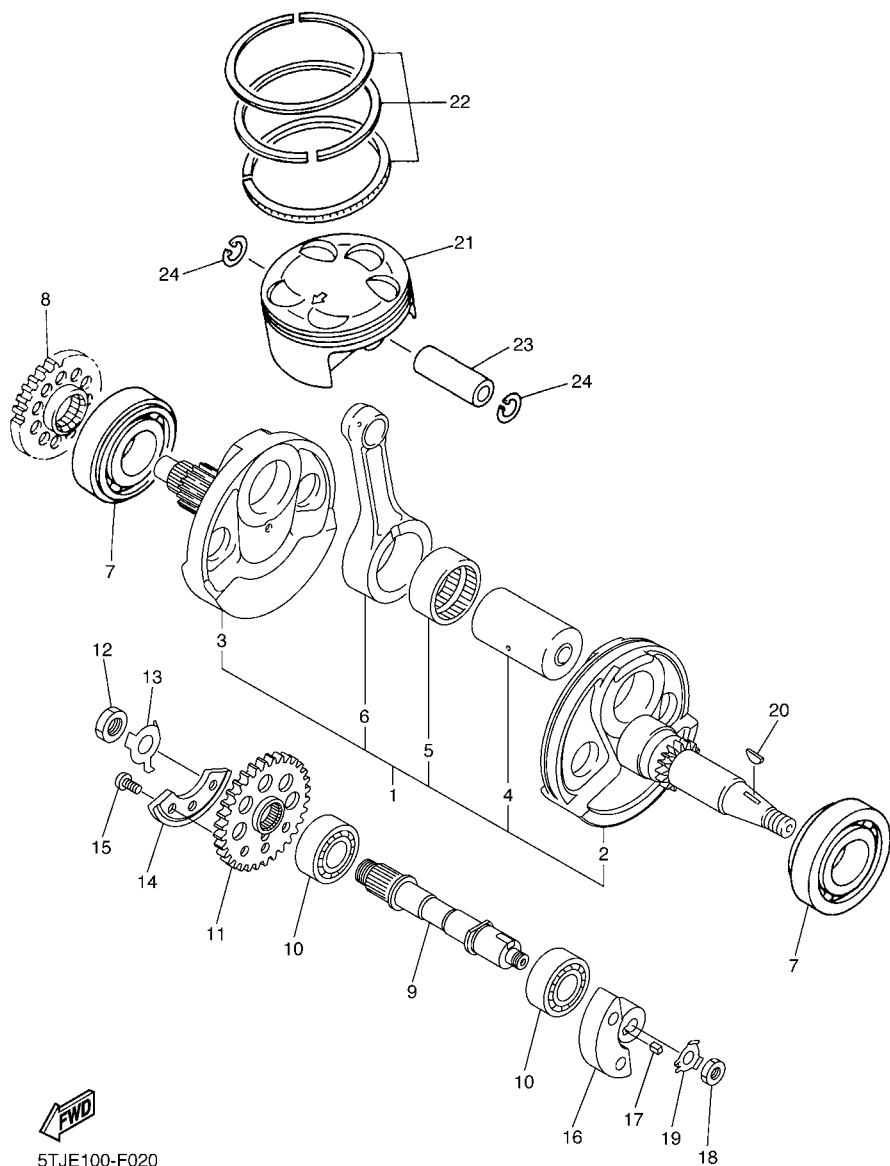

5TJE100-F020

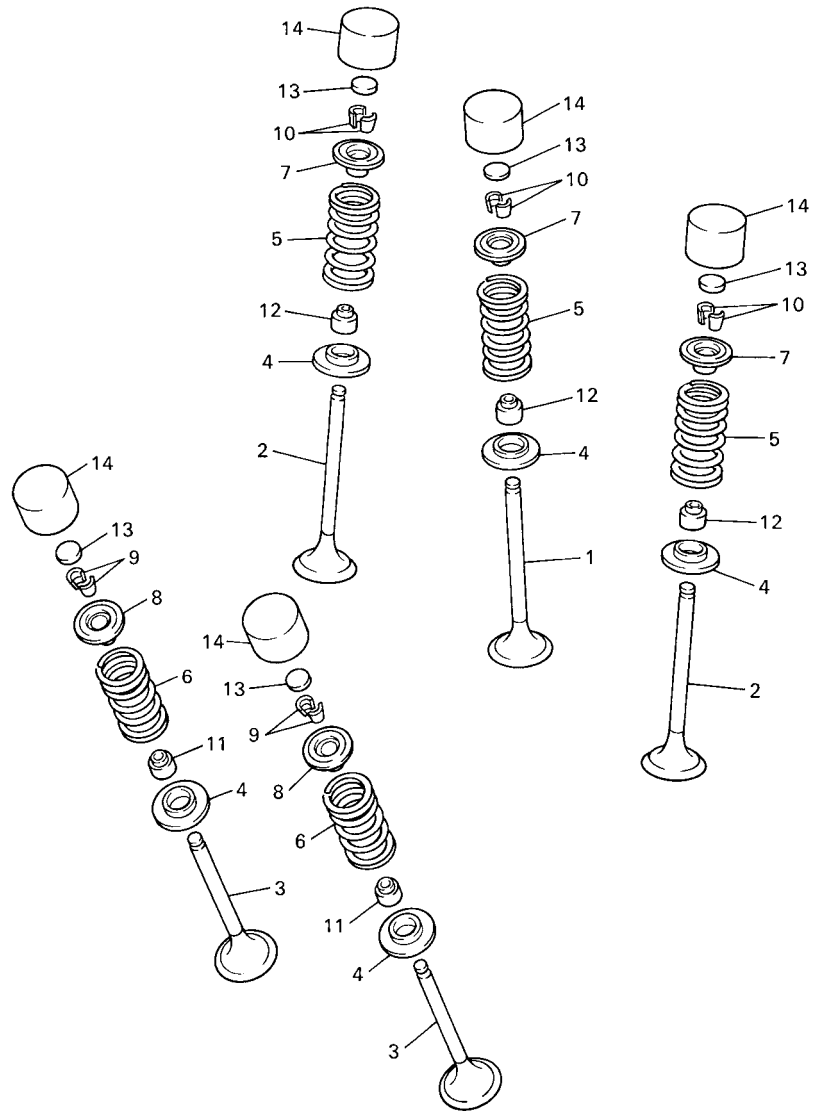

5BE100-8030

FIG. 3 VALVE

REF. NO.	PART NO.	DESCRIPTION	1HB2	1HB3	1HB4	REMARKS
1	5TA-12111-00	VALVE, INTAKE	1	1	1	
2	5TA-12112-00	VALVE, INTAKE 2	2	2	2	
3	5TA-12121-00	VALVE, EXHAUST	2	2	2	
4	3GM-12126-00	SEAT, VALVE SPRING 2	5	5	5	
5	5TJ-12113-00	SPRING, VALVE INNER	3	3	3	
6	5TJ-12114-00	SPRING, VALVE OUTER	2	2	2	
7	5BE-12117-00	RETAINER, VALVE SPRING	3	3	3	
8	4GY-12117-00	RETAINER, VALVE SPRING	2	2	2	
9	1AA-12118-00	COTTER, VALVE	4	4	4	
10	1WG-12118-00	COTTER, VALVE	6	6	6	
11	33M-12119-00	SEAL, VALVE STEM	2	2	2	
12	4SV-12119-00	SEAL, VALVE STEM	3	3	3	
13	3LD-12168-00	PAD, ADJUSTING (1.20)	5	5	5	UR
	3LD-12168-20	PAD, ADJUSTING (1.25)	5	5	5	UR
	3LD-12168-40	PAD, ADJUSTING (1.30)	5	5	5	UR
	3LD-12168-60	PAD, ADJUSTING (1.35)	5	5	5	UR
	3LD-12168-80	PAD, ADJUSTING (1.40)	5	5	5	UR
	3LD-12168-A0	PAD, ADJUSTING (1.45)	5	5	5	UR
	3LD-12168-F0	PAD, ADJUSTING (1.50)	5	5	5	UR
	3LD-12168-H1	PAD, ADJUSTING (1.55)	5	5	5	UR
	3LD-12168-K1	PAD, ADJUSTING (1.60)	5	5	5	UR
	3LD-12168-M1	PAD, ADJUSTING (1.65)	5	5	5	UR
	3LD-12168-R1	PAD, ADJUSTING (1.70)	5	5	5	UR
	3LD-12168-U1	PAD, ADJUSTING (1.75)	5	5	5	UR
	3LD-12168-W1	PAD, ADJUSTING (1.80)	5	5	5	UR
	3LD-12168-Y1	PAD, ADJUSTING (1.85)	5	5	5	UR
	3LD-12169-11	PAD, ADJUSTING (1.90)	5	5	5	UR

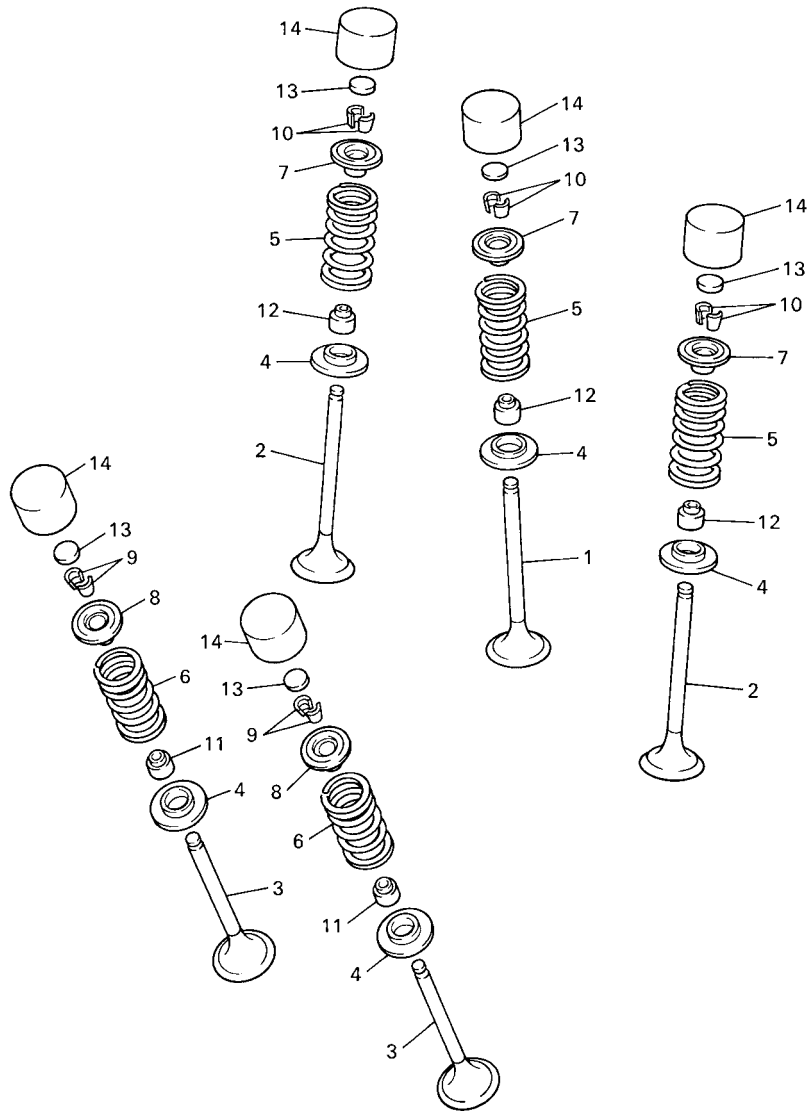

5BE100-8030

FIG. 3 VALVE

REF. NO.	PART NO.	DESCRIPTION	1HB2	1HB3	1HB4	REMARKS
13	3LD-12169-31	PAD, ADJUSTING (1.95)	5	5	5	UR
	3LD-12169-50	PAD, ADJUSTING (2.00)	5	5	5	UR
	3LD-12169-70	PAD, ADJUSTING (2.05)	5	5	5	UR
	3LD-12169-90	PAD, ADJUSTING (2.10)	5	5	5	UR
	3LD-12169-E0	PAD, ADJUSTING (2.15)	5	5	5	UR
	3LD-12169-G0	PAD, ADJUSTING (2.20)	5	5	5	UR
	3LD-12169-J0	PAD, ADJUSTING (2.25)	5	5	5	UR
	3LD-12169-L0	PAD, ADJUSTING (2.30)	5	5	5	UR
	3LD-12169-N0	PAD, ADJUSTING (2.35)	5	5	5	UR
	3LD-12169-T0	PAD, ADJUSTING (2.40)	5	5	5	UR
14	3FV-12153-10	LIFTER, VALVE	5	5	5	YELLOW

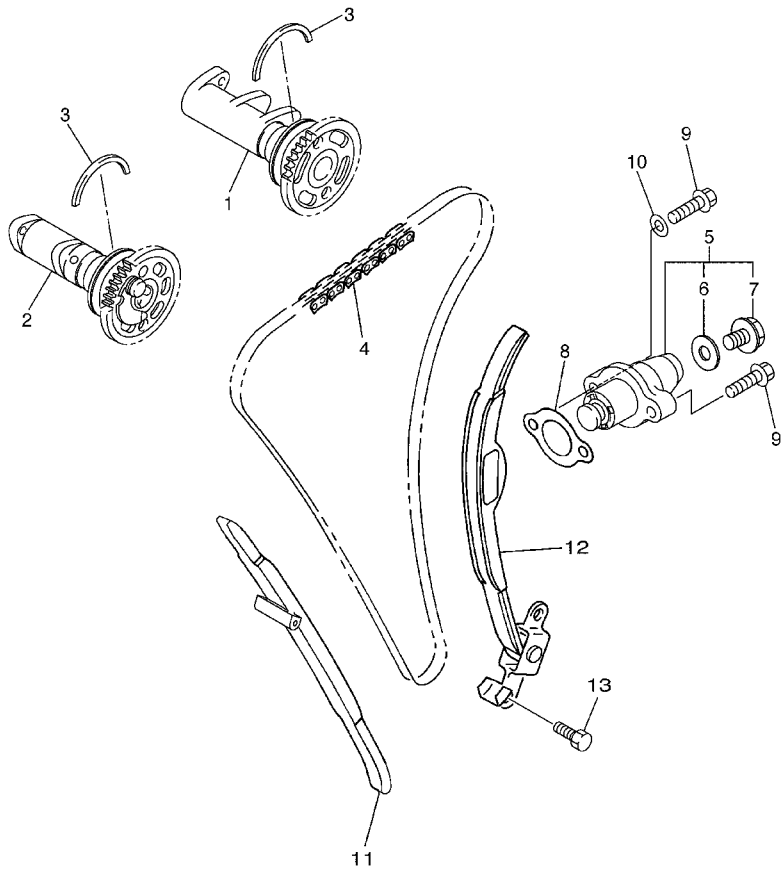

FIG. 4 CAMSHAFT & CHAIN

REF. NO.	PART NO.	DESCRIPTION	1HB2	1HB3	1HB4	REMARKS
1	5TJ-12170-00	CAMSHAFT ASSY 1	1	1	1	
2	5TJ-12180-30	CAMSHAFT ASSY 2	1	1	1	
3	93440-41178	CIRCLIP	2	2	2	
4	94591-57118	CHAIN (98XRH2010-118M)	1	1	1	
5	5TA-12210-10	TENSIONER ASSY, CAM CHAIN	1	1	1	
6	5EL-12214-00	.GASKET	1	1	1	
7	5EL-12228-00	.BOLT, FLANGE	1	1	1	
8	4FM-12213-00	GASKET, TENSIONER CASE	1	1	1	
9	95022-06025	BOLT, FLANGE	2	2	2	
10	90430-06014	GASKET	1	1	1	
11	2S2-12251-00	DAMPER, CHAIN 1	1	1	1	
12	5TA-12252-00	DAMPER, CHAIN 2	1	1	1	
13	5TJ-12299-00	BOLT, STOPPER	2	2	2	



5TJE100-F041

FIG. 6 RADIATOR & HOSE

REF. NO.	PART NO.	DESCRIPTION	1HB2	1HB3	1HB4	REMARKS
1	5TJ-1240A-E0	RADIATOR ASSY	1	1	1	
2	2S2-12464-70	.STAY, RADIATOR	1	1	1	
3	92012-06010	.BOLT, BUTTON HEAD	3	3	3	
4	90183-060A6	.NUT, SPRING	1	1	1	
5	2S2-12461-70	RADIATOR COMP	1	1	1	
6	2S2-12464-70	.STAY, RADIATOR	1	1	1	
7	92012-06010	.BOLT, BUTTON HEAD	3	3	3	
8	90183-060A6	.NUT, SPRING	1	1	1	
9	22W-12462-00	CAP, RADIATOR	1	1	1	
10	91A20-05140	TUBE, FLEXIBLE VINYL	1	1	1	
11	90467-090A2	CLIP	1	1	1	
12	2S2-12481-00	PIPE 1	1	1	1	
13	91312-06012	BOLT	1	1	1	
14	93210-16500	O-RING	1	1	1	
15	2S2-12576-00	HOSE 1	1	1	1	
16	1C3-12482-00	PIPE 2	1	1	1	
17	2S2-12578-00	HOSE 3	1	1	1	
18	5TJ-12579-E0	HOSE 4	1	1	1	
19	2S2-12482-00	PIPE 2	1	1	1	
20	95022-06012	BOLT, FLANGE	1	1	1	
21	93210-16500	O-RING	1	1	1	
22	90450-28001	HOSE CLAMP ASSY	3	3	3	
23	90450-25001	HOSE CLAMP ASSY	3	3	3	
24	90450-22001	HOSE CLAMP ASSY	2	2	2	
25	90480-15528	GROMMET	4	4	4	
26	90387-06065	COLLAR	4	4	4	
27	90105-06111	BOLT, FLANGE	4	4	4	

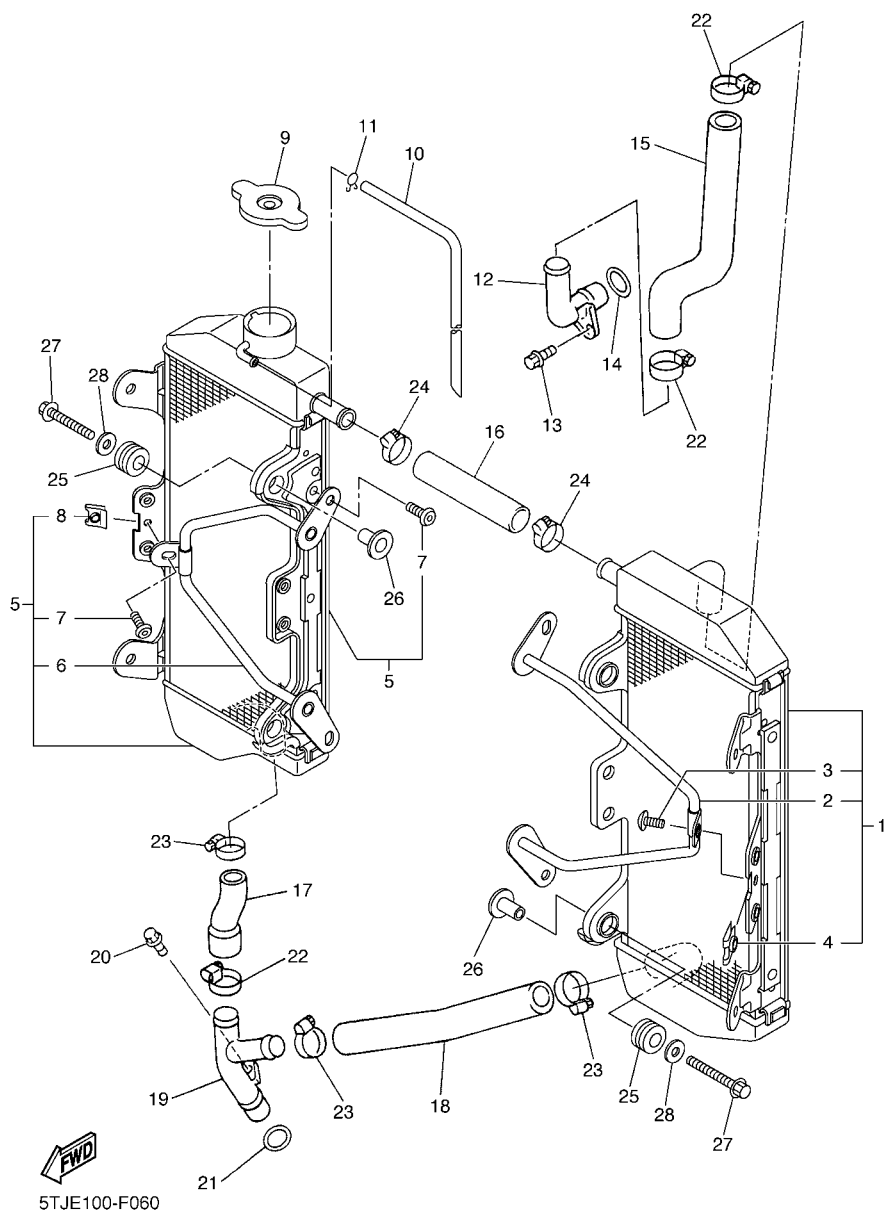

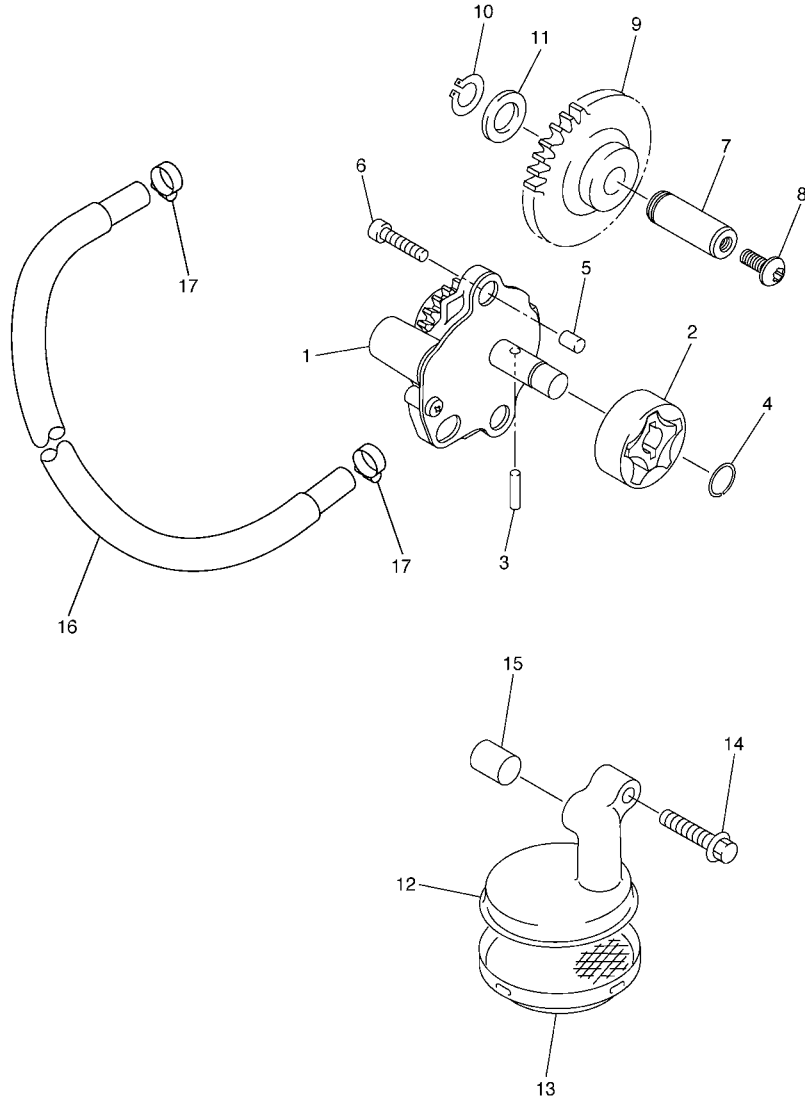

FIG. 7 OIL PUMP

REF. NO.	PART NO.	DESCRIPTION	1HB2	1HB3	1HB4	REMARKS
1	2S2-13300-10	OIL PUMP ASSY	1	1	1	
2	5TA-13320-00	ROTOR ASSY 2	1	1	1	
3	93603-16219	PIN, DOWEL	1	1	1	
4	93440-10153	CIRCLIP	1	1	1	
5	99530-08012	PIN, DOWEL	2	2	2	
6	91312-06030	BOLT	2	2	2	
7	2S2-13342-00	SHAFT, IDLE GEAR	1	1	1	
8	90149-06068	SCREW	1	1	1	
9	2S2-13341-00	GEAR, OIL PUMP IDLE	1	1	1	
10	99009-12400	CIRCLIP	1	1	1	
11	90201-12166	WASHER, PLATE	1	1	1	
12	2S2-13412-00	HOUSING, STRAINER	1	1	1	
13	5BE-13411-00	STRAINER, OIL	1	1	1	
14	95022-06030	BOLT, FLANGE	1	1	1	
15	99530-10114	PIN, DOWEL	1	1	1	
16	90445-14009	HOSE	1	1	1	
17	90450-17001	HOSE CLAMP ASSY	2	2	2	



2S21100-E070

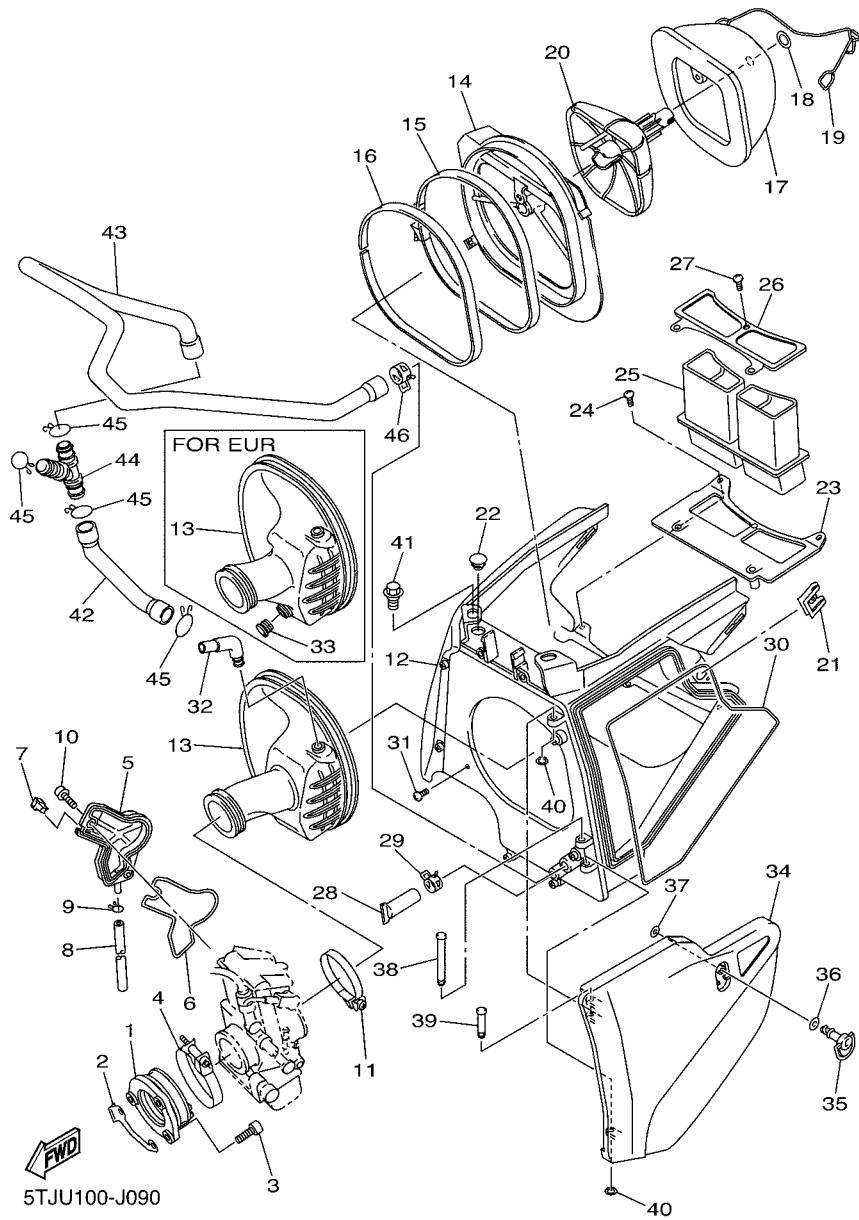

FIG. 9 INTAKE

REF. NO.	PART NO.	DESCRIPTION	1HB2	1HB3	1HB4	REMARKS
1	2S2-13597-00	JOINT, CARBURETOR 3	1	1	1	
2	5TJ-14291-00	BRACKET 1	1	1	1	
3	91312-06020	BOLT	3	3	3	
4	90450-57010	HOSE CLAMP ASSY	1	1	1	
5	5TA-14293-00	COVER 1	1	1	1	
6	5TA-14227-00	GASKET	1	1	1	
7	5TA-14239-00	SEAL	1	1	1	
8	5TA-14987-00	HOSE	1	1	1	
9	3TJ-14137-40	CLIP	1	1	1	
10	90110-05038	BOLT, HEXAGON SOCKET HEAD	2	2	2	
11	90450-61002	HOSE CLAMP ASSY	1	1	1	
12	5UM-14401-E0	AIR CLEANER CASE ASSY	1	1	1	
13	5TJ-14453-E0	JOINT, AIR CLEANER 1	1	1		
	5TJ-14453-L0	JOINT, AIR CLEANER 1		1		
14	5TJ-14459-01	HOLDER, GUIDE	1	1	1	
15	5NY-14455-20	BAND	1	1	1	
16	5NY-14442-00	SPACER	1	1	1	
17	5UM-14451-E0	ELEMENT, AIR CLEANER	1	1	1	
18	5TJ-14475-00	WASHER	1	1	1	
19	5UM-1441G-E0	BINDER 1	1	1	1	
20	5TJ-14458-00	GUIDE	1	1	1	
21	4XV-2177L-01	PLATE, SPRING	1	1	1	
22	90338-07043	PLUG	1	1	1	
23	5UM-14437-E0	DUCT	1	1	1	
24	97702-50516	SCREW, TAPPING	2	2	2	
25	5UM-1443A-E0	DUCT	1	1	1	
26	5UM-14417-E0	COVER 1	1	1	1	

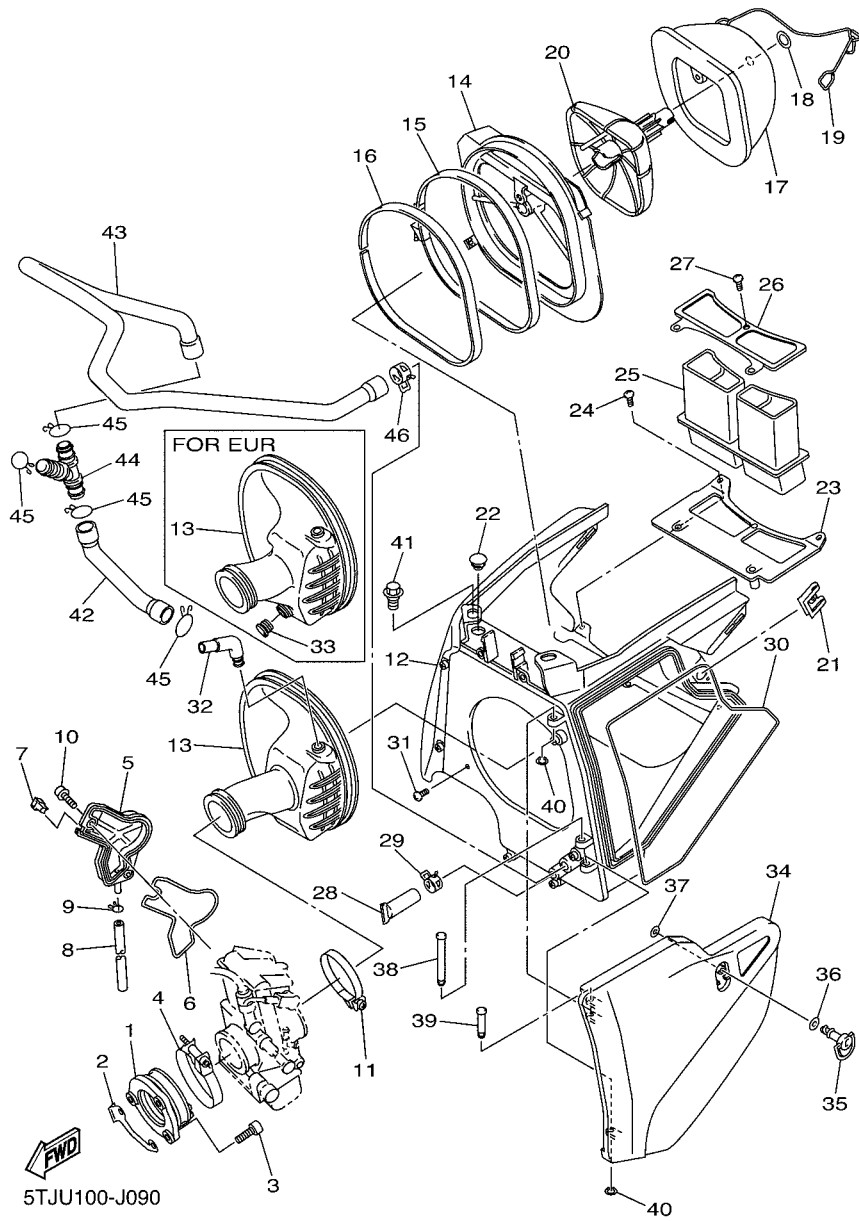

FIG. 9 INTAKE

REF. NO.	PART NO.	DESCRIPTION	1HB2	1HB3	1HB4	REMARKS
27	97702-50516	SCREW, TAPPING	3	3	3	
28	5BF-1443E-00	PIPE, DRAIN	1	1	1	
29	90467-17089	CLIP	1	1	1	
30	5UM-14462-E0	SEAL	1	1	1	
31	97702-50516	SCREW, TAPPING	1	1	1	
32	5TJ-14419-00	PIPE	1	1	1	
33	5UM-1443B-L0	PLUG, BLIND		1		
34	5UM-1441A-E0	COVER, CLEANER CASE 1	1	1	1	
35	3FV-28386-00	HEAD	1	1	1	
36	2TK-21757-00	WASHER, SPECIAL 1	1	1	1	
37	5TJ-21757-00	WASHER, SPECIAL 1	1	1	1	
38	90249-05005	PIN	1	1	1	
39	90249-05004	PIN	1	1	1	
40	99002-04600	CIRCLIP	2	2	2	
41	90109-06245	BOLT	2	2	2	
42	5TJ-11167-10	PIPE, BREATHER 2	1	1	1	
43	5TJ-11126-00	PIPE, BREATHER 3	1	1	1	
44	90413-14001	WAY 3	1	1	1	
45	90467-160A4	CLIP	4	4	4	
46	90467-17089	CLIP	1	1	1	

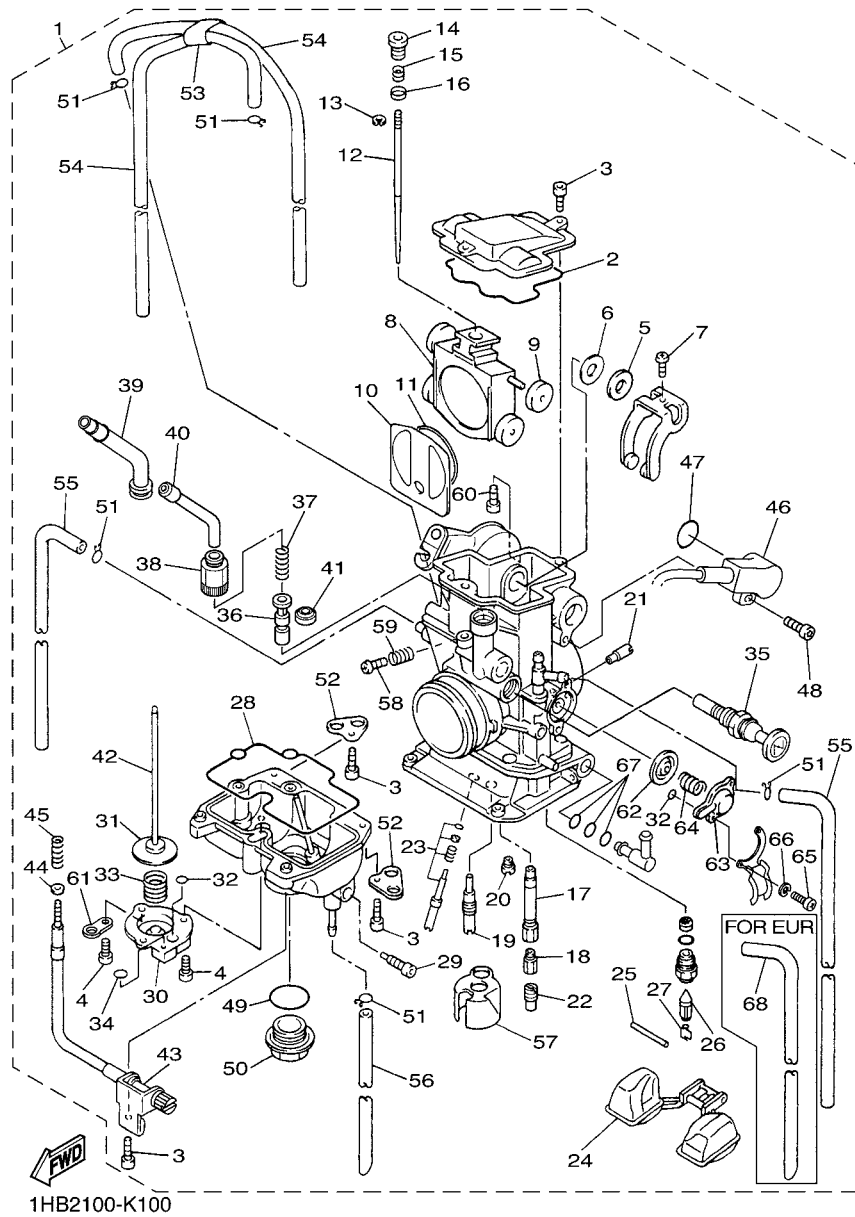

FIG. 10 CARBURETOR

REF. NO.	PART NO.	DESCRIPTION	1HB2	1HB3	1HB4	REMARKS
1	5TJ-14101-E0	CARBURETOR ASSY 1	1		1	
	5TJ-14101-L0	CARBURETOR ASSY 1		1		
2	5JG-14959-00	.GASKET	1	1	1	
3	91316-04012	.BOLT	6	6	6	
4	688-14592-00	.SCREW	3	3	3	
5	90202-08045	.WASHER, PLATE	1	1	1	
6	5JG-14951-00	.WASHER	1	1	1	
7	5JG-14522-00	.SCREW, ADJUST	1	1	1	
8	2S2-14388-00	.VALVE, VACUUM CONTROL	1	1	1	
9	3TJ-14267-40	.ROLLER	1	1	1	
10	5JG-14546-01	.VALVE, NEEDLE	1	1	1	
11	4FN-14997-00	.SEAL	1	1	1	
12	5TJ-14916-NT	.NEEDLE (NFNT)	1		1	STD
	5TJ-14916-LU	.NEEDLE (NNHU)		1		STD
	5BF-14916-8N	.NEEDLE (#DTN-K)		1		AP
	5BF-14916-8P	.NEEDLE (#DTP-K)	1			AP
	5BF-14916-81	.NEEDLE (#DTQ-K)	1			AP
	5BF-14916-8R	.NEEDLE (#DTR-K)	1			AP
	5BF-14916-8S	.NEEDLE (#DTS-K)	1			AP
	5BF-14916-8T	.NEEDLE (#DTT-K)	1			AP
	5BF-14916-8U	.NEEDLE (#DTU-K)	1			AP
	5TJ-14916-9M	.NEEDLE (GDDUM)		1		AP
	5TJ-14916-9N	.NEEDLE (GDDUN)		1		AP
	5TJ-14916-9P	.NEEDLE (GDDUP)		1		AP
	5TJ-14916-91	.NEEDLE (GDDUQ)		1		AP
	5TJ-14916-9R	.NEEDLE (GDDUR)		1		AP
	5TJ-14916-9S	.NEEDLE (GDDUS)		1		AP

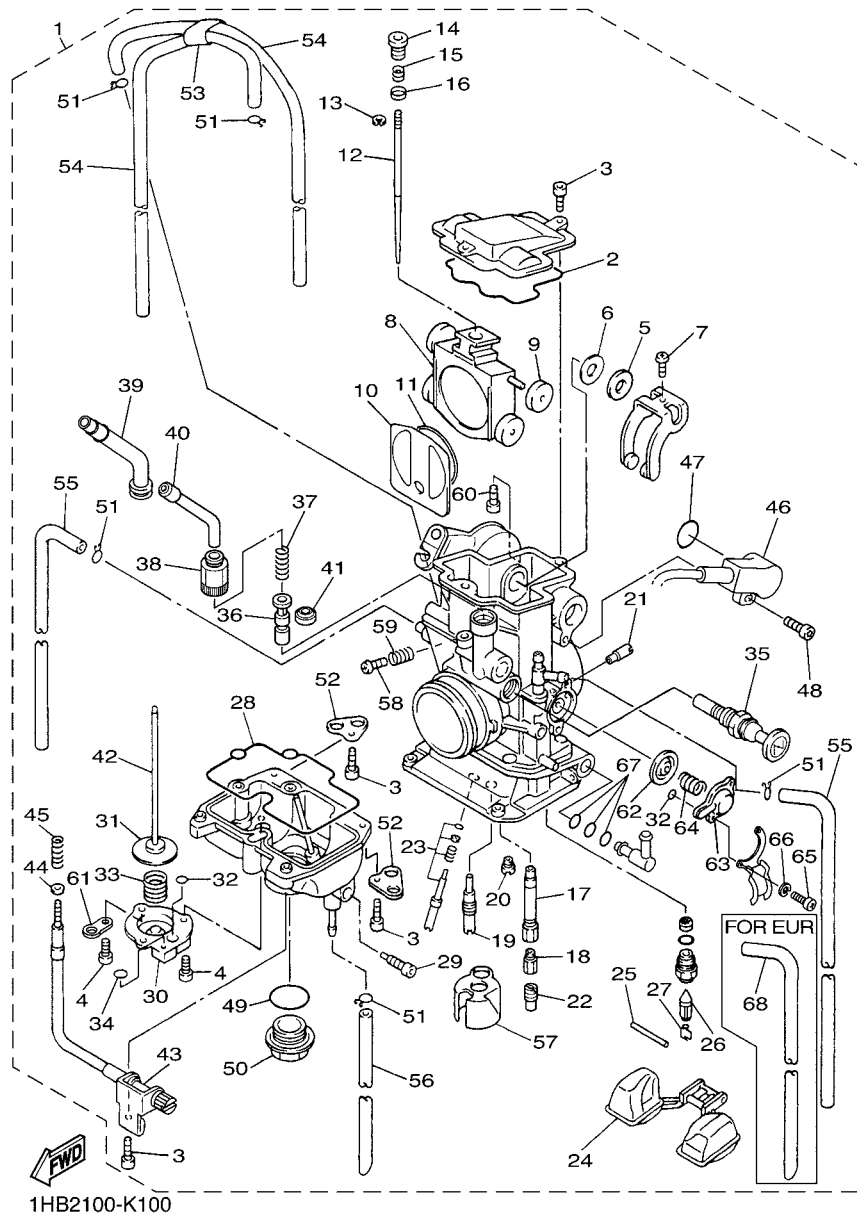

FIG. 10 CARBURETOR

REF. NO.	PART NO.	DESCRIPTION	1HB2	1HB3	1HB4	REMARKS
12	5TJ-14916-9T	.NEEDLE (GDDUT)		1		AP
	5TJ-14916-AM	.NEEDLE (GDDSM)			1	AP
	5TJ-14916-AN	.NEEDLE (GDDSN)			1	AP
	5TJ-14916-AP	.NEEDLE (GDDSP)			1	AP
	5TJ-14916-A1	.NEEDLE (GDDSQ)			1	AP
	5TJ-14916-AR	.NEEDLE (GDDSR)			1	AP
	5TJ-14916-AS	.NEEDLE (GDDSS)			1	AP
	5TJ-14916-AT	.NEEDLE (GDDST)			1	AP
13	3TJ-14159-40	.CLIP	1	1	1	
14	5JG-14521-00	.SCREW, ADJUST	1	1	1	
15	5JG-14275-00	.SPRING	1	1	1	
16	5JG-14264-00	.COLLAR	1	1	1	
17	5TJ-14947-00	.JET, NEEDLE	1	1	1	
18	4MX-14943-90	.JET, MAIN (#162)	1		1	STD
	4MX-14943-39	.JET, MAIN (#160)			1	STD
	4MX-14943-90	.JET, MAIN (#162)			1	AP
	4MX-14943-40	.JET, MAIN (#165)			1 1	AP
	4MX-14943-91	.JET, MAIN (#168)			1 1	AP
	4MX-14943-41	.JET, MAIN (#170)			1 1	AP
	4MX-14943-92	.JET, MAIN (#172)			1 1	AP
	4MX-14943-42	.JET, MAIN (#175)			1 1	AP
	4MX-14943-93	.JET, MAIN (#178)			1 1	AP
	4MX-14943-43	.JET, MAIN (#180)			1 1	AP
	4MX-14943-94	.JET, MAIN (#182)			1 1	AP
	4MX-14943-44	.JET, MAIN (#185)			1 1	AP
19	4MX-14948-05	.JET, SLOW (#45)	1		1	STD
	4MX-14948-06	.JET, SLOW (#48)			1	STD

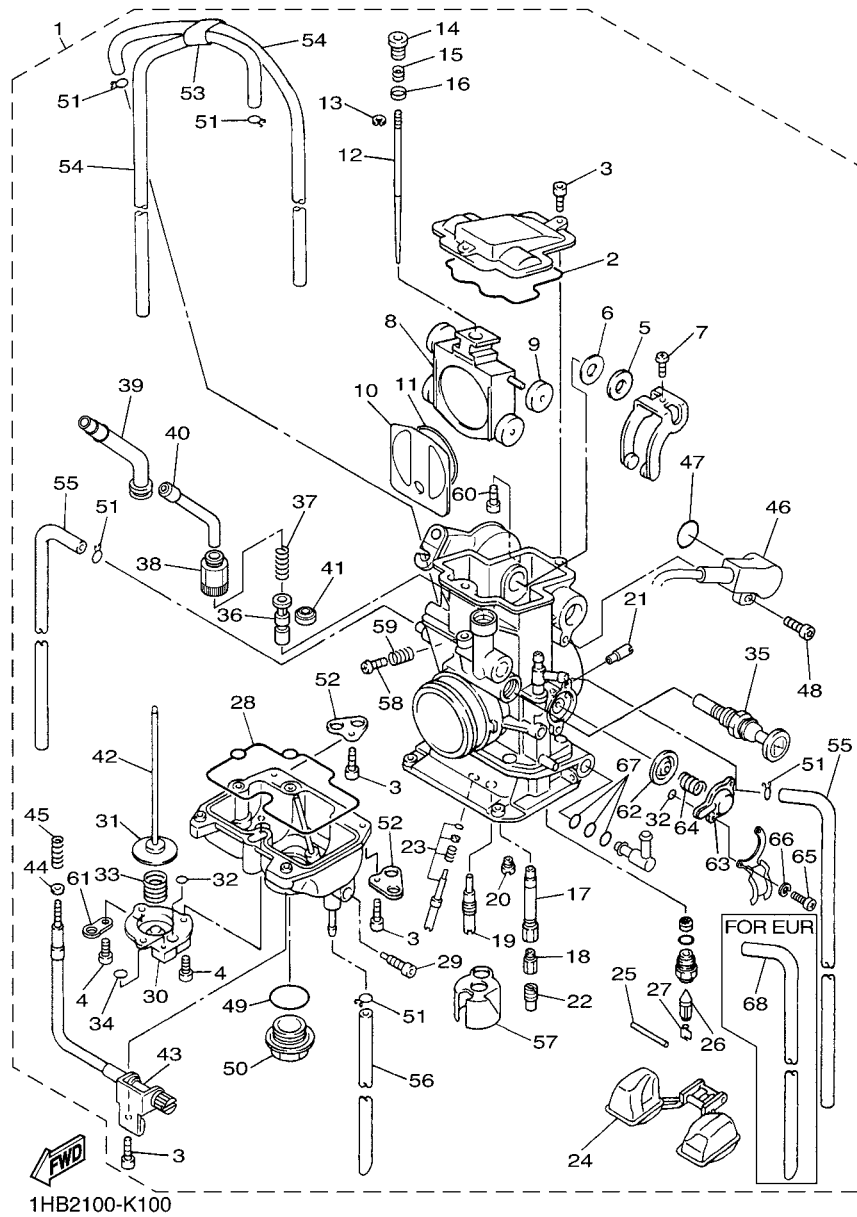

FIG. 10 CARBURETOR

REF. NO.	PART NO.	DESCRIPTION	1HB2	1HB3	1HB4	REMARKS
19	4MX-14948-05	.JET, SLOW (#45)		1		AP
	4MX-14948-06	.JET, SLOW (#48)			1	AP
	4MX-14948-07	.JET, SLOW (#50)		1	1	AP
	4MX-14948-08	.JET, SLOW (#52)		1	1	AP
	4MX-14948-09	.JET, SLOW (#55)		1	1	AP
20	3TJ-1494F-13	.JET (#65)	1	1	1	STD
	3TJ-1494F-11	.JET (#60)		1	1	AP
	3TJ-1494F-12	.JET (#62)		1	1	AP
	3TJ-1494F-14	.JET (#68)		1	1	AP
	3TJ-1494F-15	.JET (#70)		1	1	AP
21	5TA-14943-15	.JET, MAIN (#70)	1	1	1	
22	4JT-1494F-11	.JET (#60)	1	1	1	STD
	4JT-1494F-01	.JET (#35)		1	1	AP
	4JT-1494F-03	.JET (#40)		1	1	AP
	4JT-1494F-05	.JET (#45)		1	1	AP
	4JT-1494F-07	.JET (#50)		1	1	AP
	4JT-1494F-09	.JET (#55)		1	1	AP
	4JT-1494F-13	.JET (#65)		1	1	AP
	5UM-1494F-29	.JET (#110)			1	AP
23	5NL-14105-00	.PILOT SCREW SET	1	1	1	
24	4SR-14985-00	.FLOAT	1	1	1	
25	676-14548-00	.PIN, FLOAT ARM	1	1	1	
26	4MX-14392-00	.VALVE, NEEDLE	1	1	1	
27	633-14159-00	.CLIP	1	1	1	
28	5JG-14984-00	.GASKET, FLOAT CHAMBER	1	1	1	
29	3TJ-14191-40	.PLUG, DRAIN	1	1	1	
30	3TJ-14293-40	.COVER 1	1	1	1	

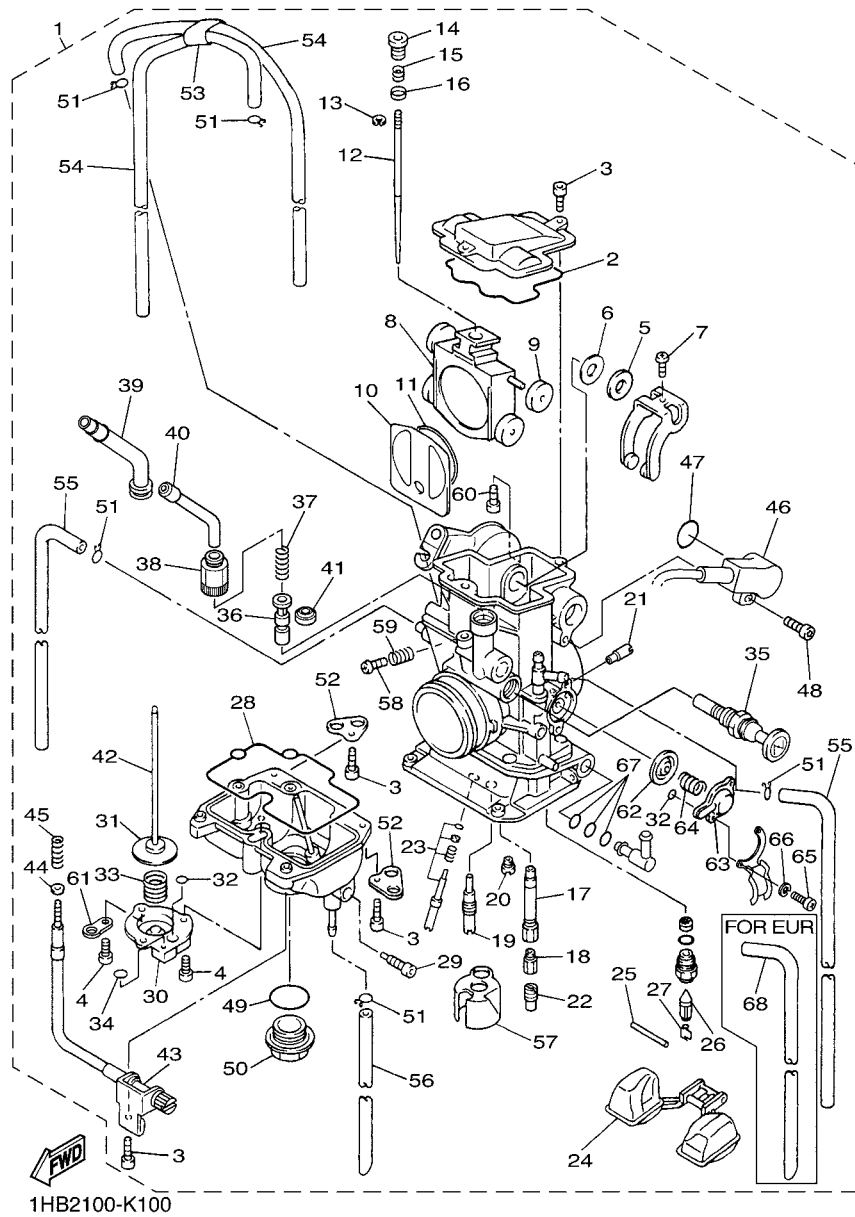

FIG. 10 CARBURETOR

REF. NO.	PART NO.	DESCRIPTION	1HB2	1HB3	1HB4	REMARKS
31	5JG-14940-18	.DIAPHRAGM, ACC PUMP (DPH#25)	1	1	1	STD
	5JG-14940-17	.DIAPHRAGM, ACC PUMP (DPH#35)		1	1	AP
	5JG-14940-19	.DIAPHRAGM, ACC PUMP (DPH#15)		1	1	AP
32	3TJ-14536-40	.GASKET	2	2	2	
33	5GS-14933-40	.SPRING, DIAPHRAGM	1	1	1	
34	6H4-14561-00	.O-RING	1	1	1	
35	5XC-14171-00	.PLUNGER, STARTER	1	1	1	
36	5TA-14371-00	.PLUNGER, STARTER	1	1	1	
37	5TA-14335-00	.SPRING, PLUNGER	1	1	1	
38	5TA-14991-00	.SCREW	1	1	1	
39	2S2-14208-00	.LEVER COMP. 1	1	1	1	
40	5TA-14155-00	.GUIDE, CABLE	1	1	1	
41	5TA-14997-00	.SEAL	1	1	1	
42	5JG-14379-00	.ROD, STARTER	1	1	1	
43	5XC-14922-00	.SCREW, THROTTLE	1	1	1	
44	90201-08410	.WASHER, PLATE	1	1	1	
45	5TA-14934-00	.SPRING, THROTTLE STOP	1	1	1	
46	5XC-85885-00	.THROTTLE SENSOR ASSY	1	1	1	
47	5NX-14562-00	.O-RING	1	1	1	
48	5NX-14216-00	.SCREW	1	1	1	
49	4MX-14561-00	.O-RING	1	1	1	
50	4MX-14115-00	.PLUG, SCREW	1	1	1	
51	3TJ-14137-40	.CLIP	5	5	5	
52	5BE-14146-00	.PLATE	2	2	2	
53	5TA-14261-00	.HOLDER	1	1	1	
54	5UL-14196-00	.PIPE, OVER FLOW 1	2	2	2	
55	5TA-14197-00	.PIPE	2	2		

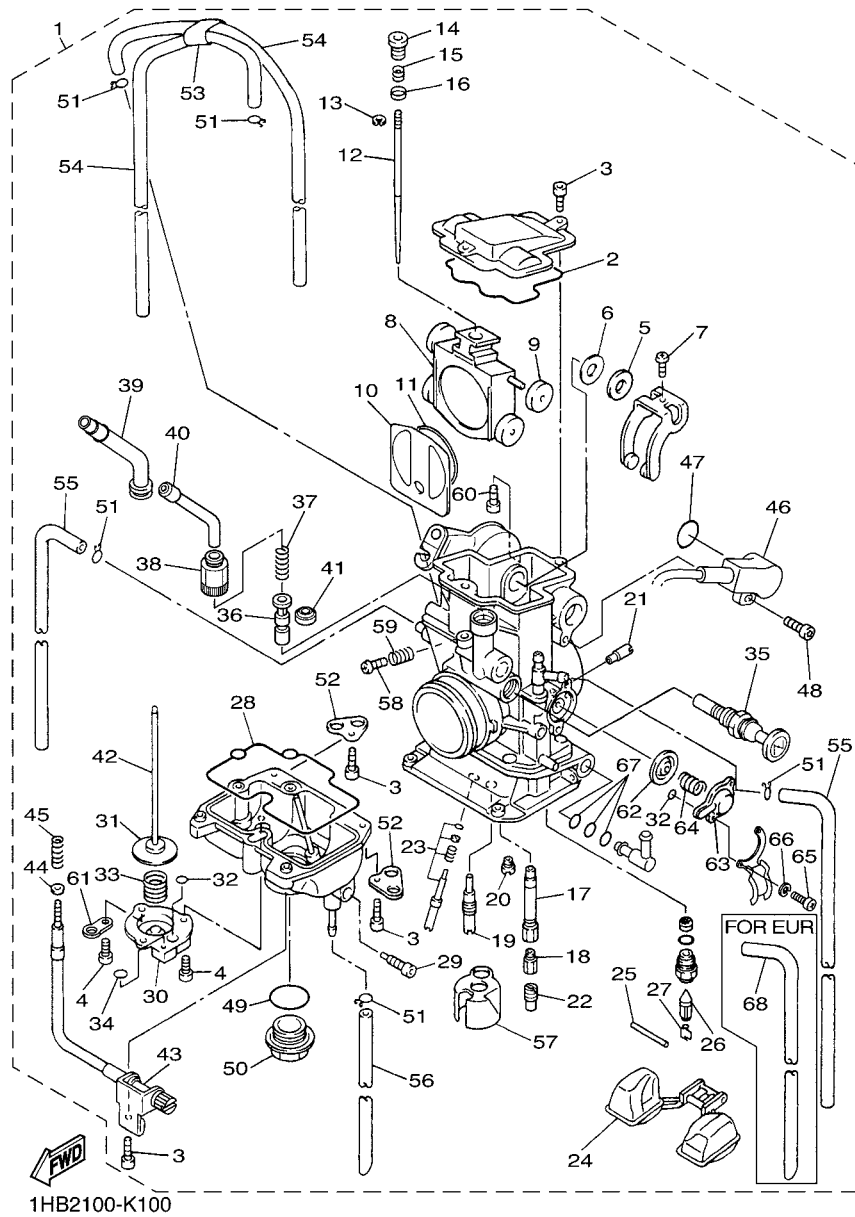
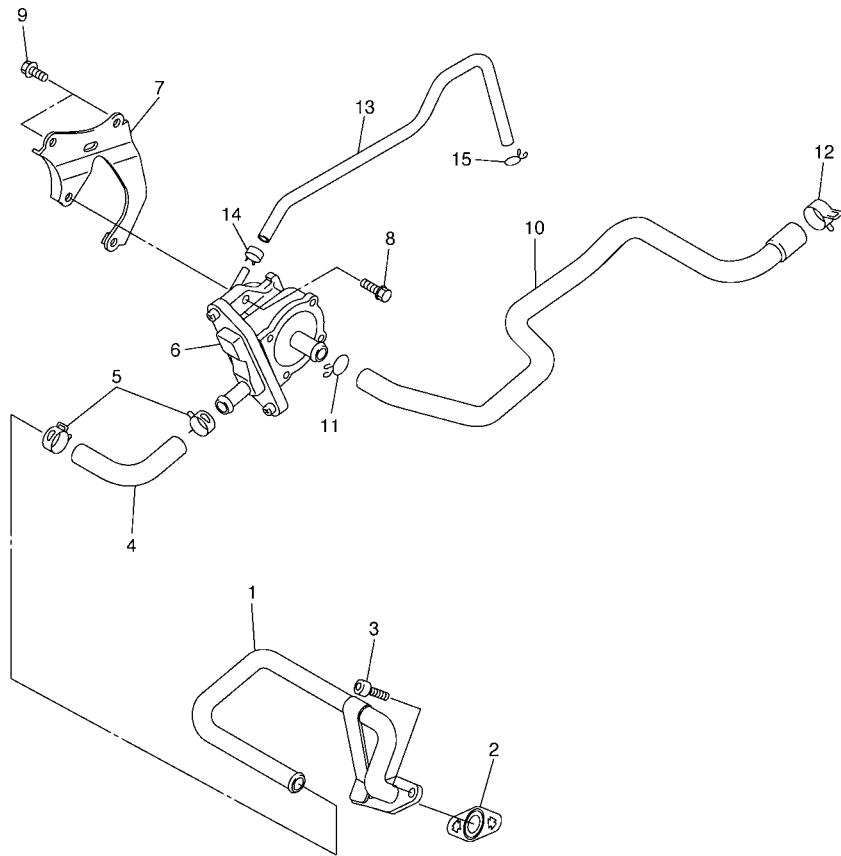

FIG. 10 CARBURETOR

REF. NO.	PART NO.	DESCRIPTION	1HB2	1HB3	1HB4	REMARKS
55	5TA-14197-00	.PIPE		1		
56	5TJ-14987-00	.HOSE	1	1	1	
57	5JG-14346-00	.PLATE	1	1	1	
58	5JG-14565-00	.SCREW	1	1	1	
59	5JG-14531-00	.SPRING, ADJUST SCREW	1	1	1	
60	5TJ-14591-10	.SCREW	1		1	
	5TJ-14591-20	.SCREW		1		
61	5PA-14146-00	.PLATE	1	1	1	
62	5GS-14940-00	.DIAPHRAGM ASSY	1	1	1	
63	5GS-14958-00	.COVER, DIAPHRAGM	1	1	1	
64	5GS-14933-00	.SPRING, DIAPHRAGM	1	1	1	
65	98502-04010	.SCREW, PAN HEAD	2	2	2	
66	92902-04100	.WASHER, SPRING	2	2	2	
67	3TJ-14564-40	.O-RING	3	3	3	
68	5UM-14197-00	.PIPE		1		



5TJE100-F110

FIG. 11 AIR INDUCTION SYSTEM

REF. NO.	PART NO.	DESCRIPTION	1HB2	1HB3	1HB4	REMARKS
1	5TJ-14871-10	PIPE 1	1	1	1	
2	5TJ-14815-00	GASKET	1	1	1	
3	91314-06016	BOLT, HEXAGON SOCKET HEAD	2	2	2	
4	5TJ-14881-10	HOSE, BEND 1	1	1	1	
5	90467-16063	CLIP	2	2	2	
6	5UM-14803-00	AIR INDUCTION SYSTEM ASSY	1	1	1	
7	5TJ-14834-E0	STAY	1	1	1	
8	90105-06107	BOLT, FLANGE	2	2	2	
9	90105-06105	BOLT, FLANGE	2	2	2	
10	5TJ-14882-10	HOSE, BEND 2	1	1	1	
11	90467-140A4	CLIP	1	1	1	
12	90467-17089	CLIP	1	1	1	
13	90445-082K4	HOSE (L250)	1	1	1	
14	90467-07138	CLIP	1	1	1	
15	90467-09006	CLIP	1	1	1	

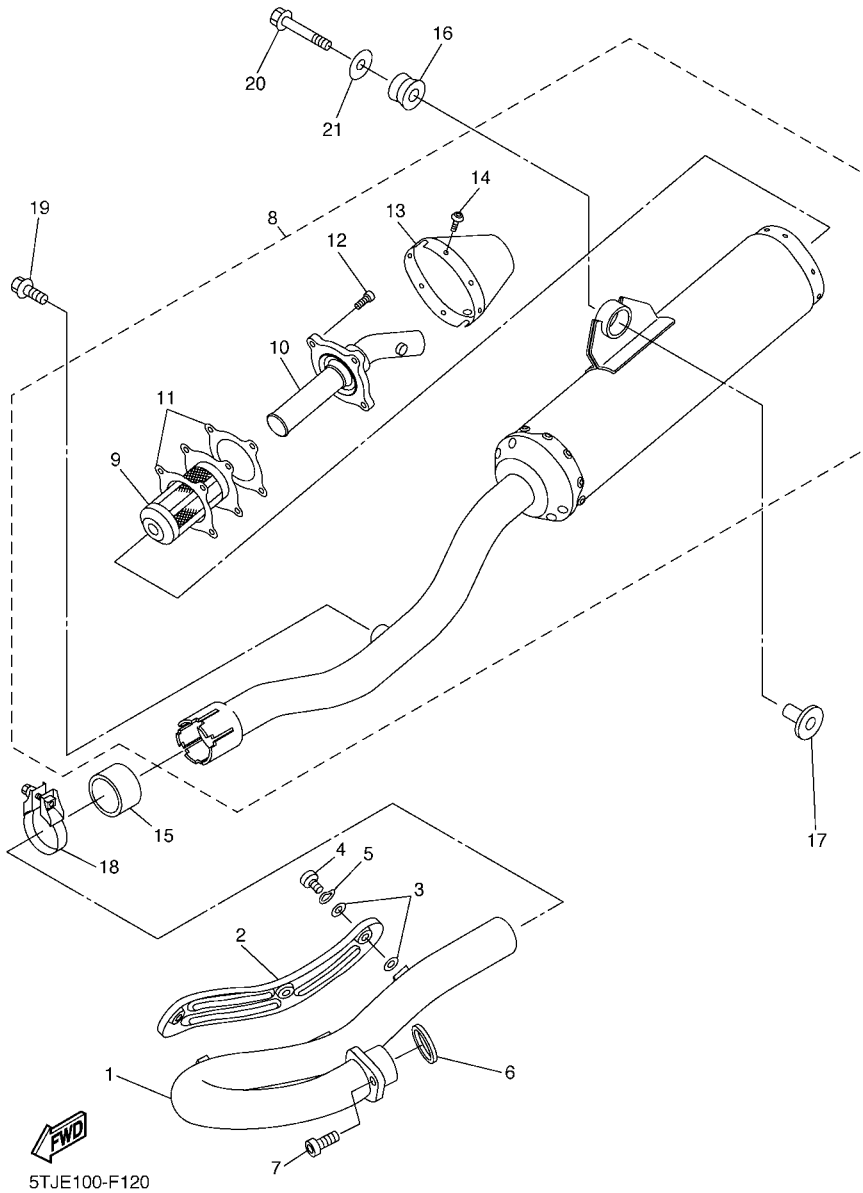
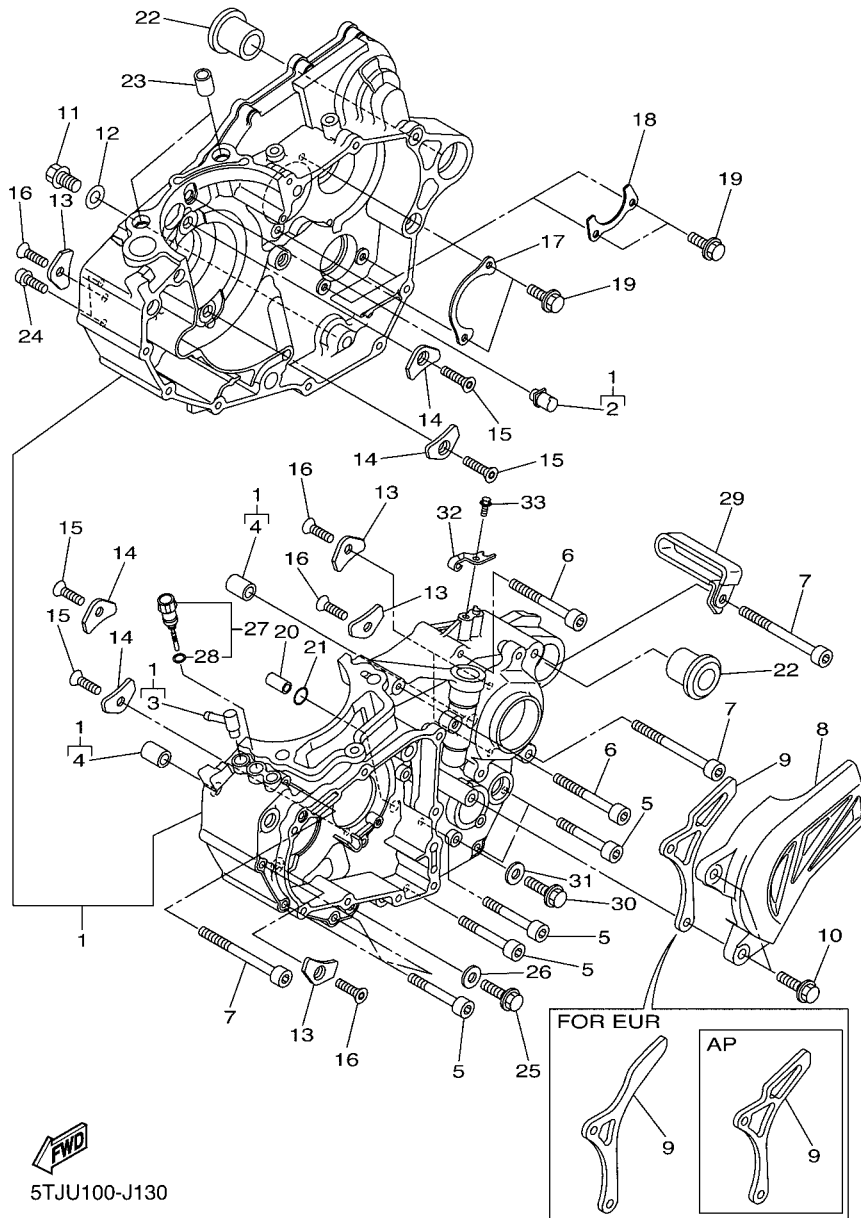

FIG. 12 EXHAUST

REF. NO.	PART NO.	DESCRIPTION	1HB2	1HB3	1HB4	REMARKS
1	5TJ-14611-10	PIPE, EXHAUST 1	1	1	1	
2	5TA-14628-00	PROTECTOR, EXHAUST PIPE	1	1	1	
3	4BD-14766-00	WASHER, PROTECTOR	6	6	6	
4	98980-06008	SCREW, BIND	3	3	3	
5	90206-06090	WASHER, WAVE	3	3	3	
6	3VD-14613-01	GASKET, EXHAUST PIPE	1	1	1	
7	90110-08097	BOLT, HEXAGON SOCKET HEAD	1	1	1	
8	5TJ-14710-E0	MUFFLER ASSY 1	1	1	1	
9	5TJ-14780-00	.SPARK ARRESTER ASSY	1	1	1	
10	5TJ-14784-00	.PIPE, TAIL	1	1	1	
11	5TJ-14623-00	.GASKET, EXHAUST PIPE	2	2	2	
12	90110-05041	.BOLT, HEXAGON SOCKET HEAD	4	4	4	
13	5TJ-14799-00	.CAP	1	1	1	
14	92012-05008	.BOLT, BUTTON HEAD	6	6	6	
15	5PH-14714-00	GASKET, MUFFLER	1	1	1	
16	5BE-14747-00	DAMPER, MUFFLER	1	1	1	
17	90387-08081	COLLAR	1	1	1	
18	5BE-14788-00	BAND, SILENCER	1	1	1	
19	90105-08307	BOLT, FLANGE	1	1	1	
20	90105-08137	BOLT, FLANGE	1	1	1	
21	90201-08061	WASHER, PLATE	1	1	1	



5TJU100-J130

FIG. 13 CRANKCASE

REF. NO.	PART NO.	DESCRIPTION	1HB2	1HB3	1HB4	REMARKS
1	2S2-15100-11	CRANKCASE ASSY	1	1	1	
2	2S2-15155-10	.NOZZLE 3	1	1	1	
3	5XC-15373-00	.PIPE, BREATHER	1	1	1	
4	99530-14016	.PIN, DOWEL	2	2	2	
5	91312-06050	BOLT	7	7	7	
6	91312-06060	BOLT	2	2	2	
7	91312-06080	BOLT	3	3	3	
8	2S2-15421-10	COVER, CRANKCASE 2	1	1	1	
9	2S2-17466-00	GUIDE, CHAIN	1	1		
	5TJ-17466-00	GUIDE, CHAIN		1		STD
	2S2-17466-00	GUIDE, CHAIN		1		AP 13T SPROCKET
10	90105-06189	BOLT, FLANGE	2	2	2	
11	95022-10016	BOLT, FLANGE	1	1	1	
12	90430-10188	GASKET	1	1	1	
13	4JT-15381-01	PLATE, BEARING COVER	4	4	4	
14	5BE-15383-01	PLATE, BEARING COVER	4	4	4	
15	90151-06071	SCREW, COUNTERSUNK	4	4	4	
16	90149-06074	SCREW	4	4	4	
17	2S2-15388-00	PLATE, BEARING COVER	1	1	1	
18	2S2-18562-00	PLATE, STOPPER 2	1	1	1	
19	90105-06081	BOLT, FLANGE	4	4	4	
20	99530-10114	PIN, DOWEL	1	1	1	
21	93210-10197	O-RING	1	1	1	
22	90387-18007	COLLAR	2	2	2	
23	99530-14016	PIN, DOWEL	2	2	2	
24	91312-06030	BOLT	2	2	2	
25	95822-08016	BOLT, FLANGE	1	1	1	

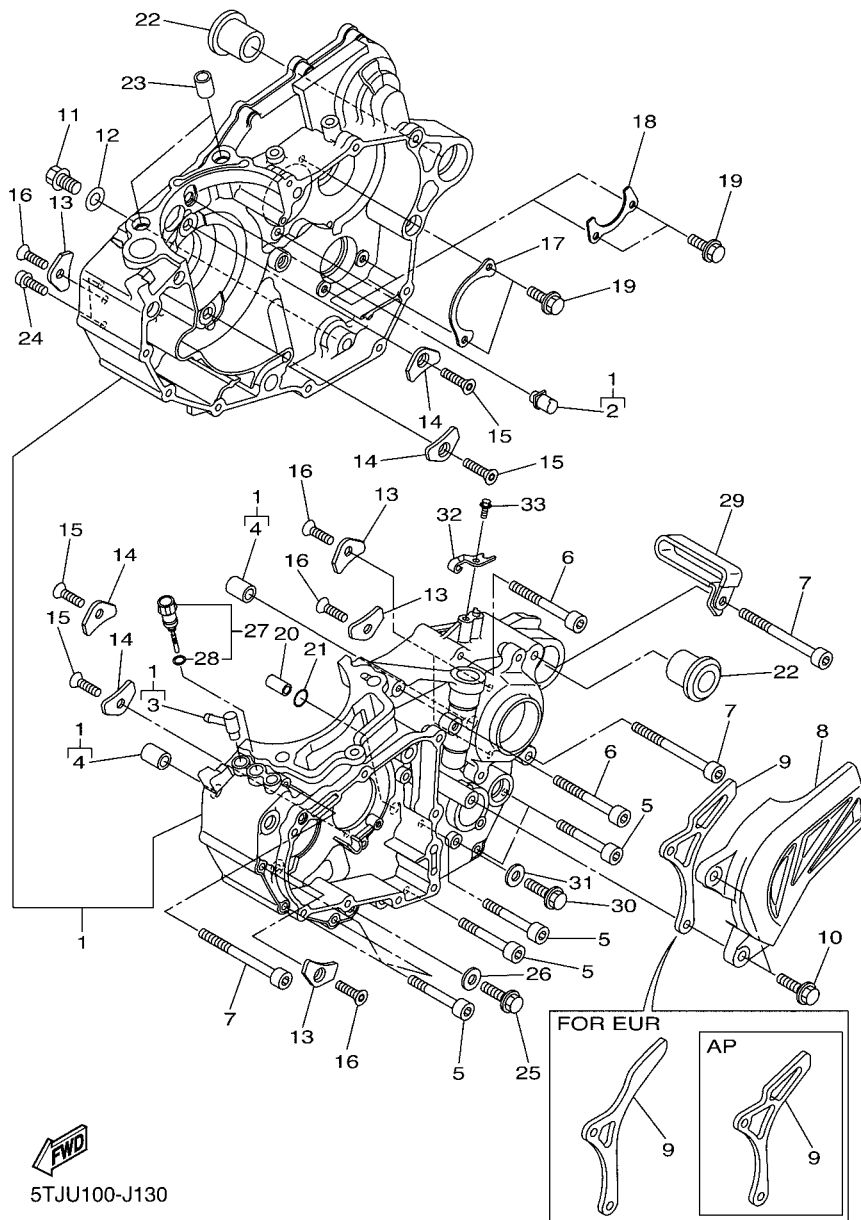

FWD
5TJU100-J130

FIG. 13 CRANKCASE

REF. NO.	PART NO.	DESCRIPTION	1HB2	1HB3	1HB4	REMARKS
26	90430-08119	GASKET	1	1	1	
27	2S2-1536A-00	PLUG, OIL LEVEL	1	1	1	
28	93210-09165	.O-RING	1	1	1	
29	90461-10136	CLAMP	1	1	1	
30	95022-06012	BOLT, FLANGE	1	1	1	
31	90430-06014	GASKET	1	1	1	
32	5TA-15441-01	HOLDER, CLUTCH CABLE	1	1	1	
33	95022-06016	BOLT, FLANGE	1	1	1	

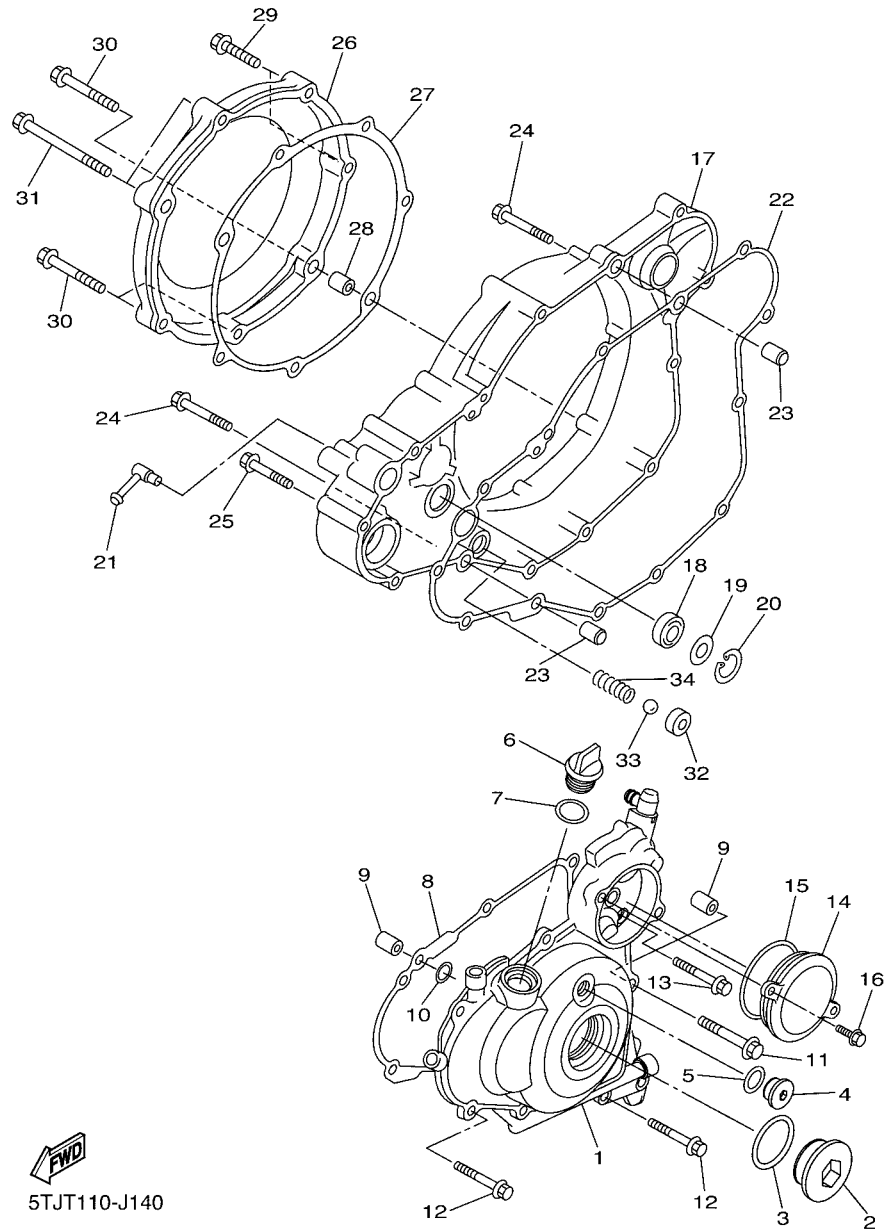

5TJT110-J140

FIG. 14 CRANKCASE COVER 1

REF. NO.	PART NO.	DESCRIPTION	1HB2	1HB3	1HB4	REMARKS
1	5TJ-15411-30	COVER, CRANKCASE 1	1	1	1	
2	90340-27003	PLUG, STRAIGHT SCREW	1	1	1	
3	93210-27370	O-RING	1	1	1	
4	90340-14003	PLUG, STRAIGHT SCREW	1	1	1	
5	93210-14369	O-RING	1	1	1	
6	3Y1-15363-10	PLUG, OIL	1	1	1	
7	93210-19123	O-RING	1	1	1	
8	2S2-15451-00	GASKET, CRANKCASE COVER 1	1	1	1	
9	99530-08016	PIN, DOWEL	2	2	2	
10	93210-08003	O-RING	1	1	1	
11	95022-06040	BOLT, FLANGE	1	1	1	
12	95022-06030	BOLT, FLANGE	6	6	6	
13	95022-06020	BOLT, FLANGE	1	1	1	
14	5TJ-1549B-20	COVER ASSY 2	1	1	1	
15	93210-58346	O-RING	1	1	1	
16	95022-06016	BOLT, FLANGE	2	2	2	
17	2S2-15431-00	COVER, CRANKCASE 3	1	1	1	
18	93101-14164	OIL SEAL	1	1	1	
19	90201-15701	WASHER, PLATE (T=1.0)	1	1	1	
20	99009-22500	CIRCLIP	1	1	1	
21	5XC-15373-00	PIPE, BREATHER	1	1	1	
22	2S2-15462-10	GASKET, CRANKCASE COVER 3	1	1	1	
23	91812-16001	PIN, DOWEL	2	2	2	
24	95022-06040	BOLT, FLANGE	2	2	2	
25	95022-06030	BOLT, FLANGE	6	6	6	
26	5TA-15415-20	COVER, GENERATOR	1	1	1	
27	5TA-15453-00	GASKET	1	1	1	

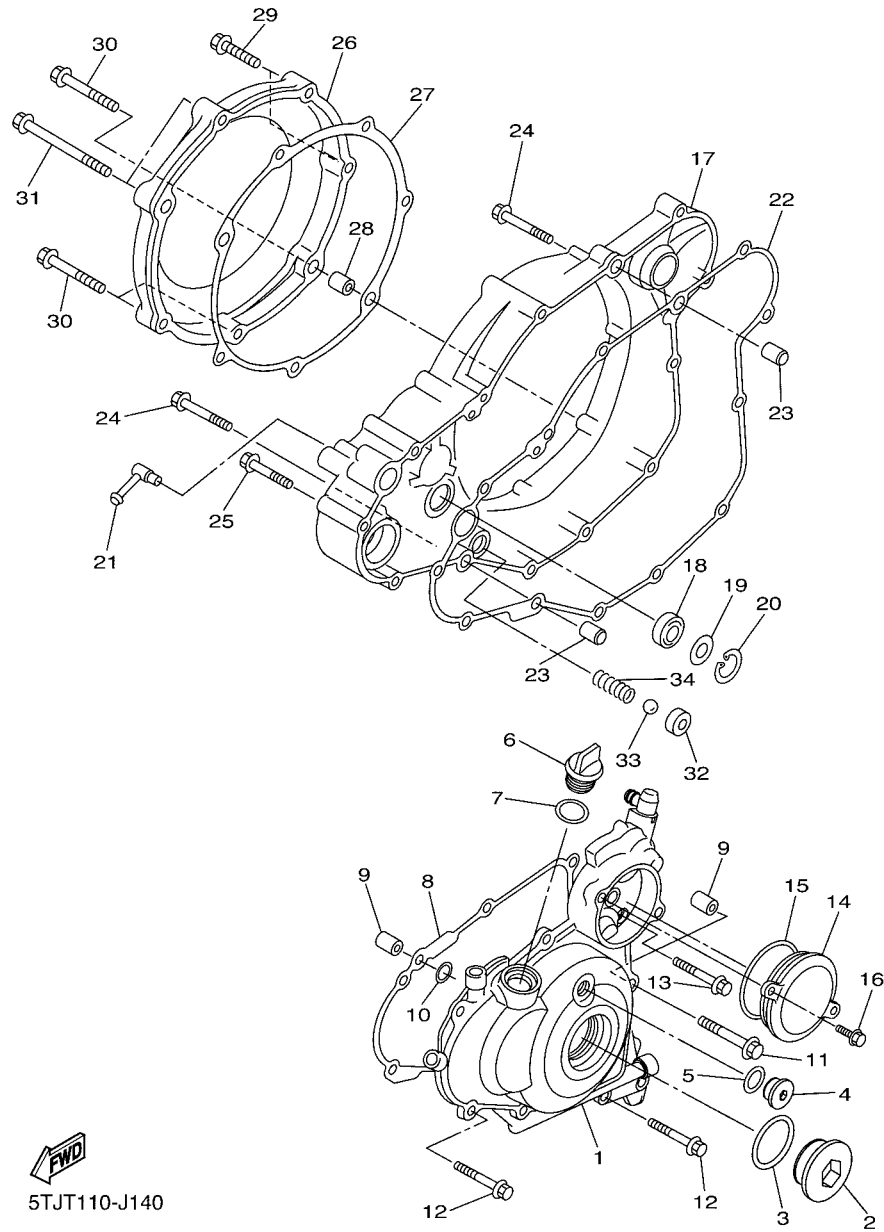

5TJT110-J140

FIG. 14 CRANKCASE COVER 1

REF. NO.	PART NO.	DESCRIPTION	1HB2	1HB3	1HB4	REMARKS
28	99530-08016	PIN, DOWEL	2	2	2	
29	95022-06030	BOLT, FLANGE	2	2	2	
30	95022-06040	BOLT, FLANGE	3	3	3	
31	95022-06080	BOLT, FLANGE	2	2	2	
32	583-13113-00	SEAT, CHECK BALL	1	1	1	
33	93503-08007	BALL	1	1	1	
34	90501-043E0	SPRING, COMPRESSION	1	1	1	

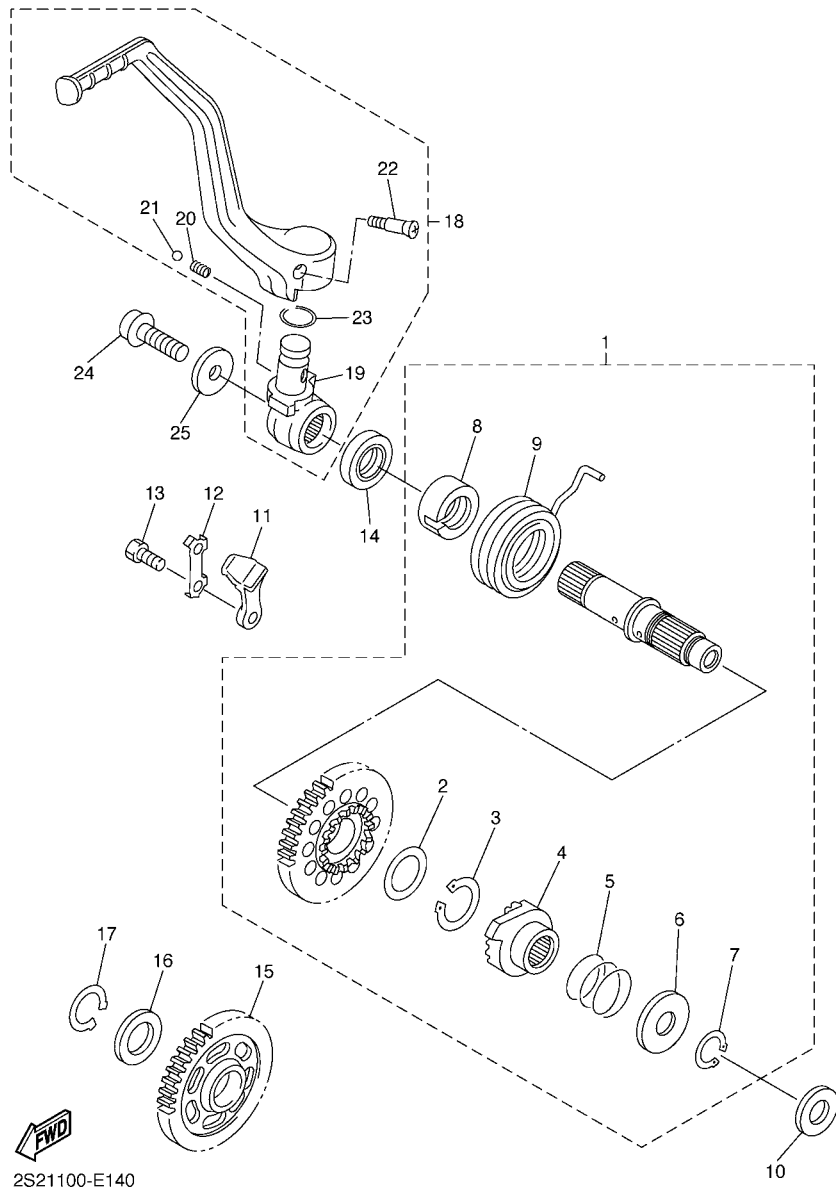
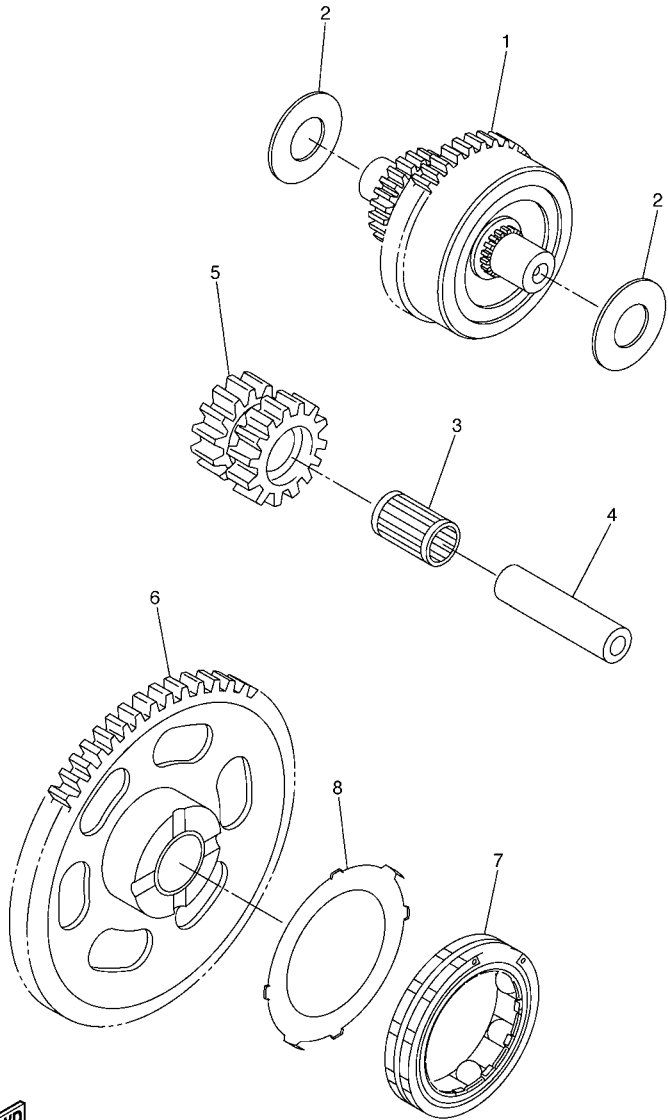

FIG. 15 STARTER

REF. NO.	PART NO.	DESCRIPTION	1HB2	1HB3	1HB4	REMARKS
1	2S2-15601-00	KICK SHAFT ASSY	1	1	1	
2	90201-20685	.WASHER, PLATE (T=0.5)	1	1	1	
3	93410-20038	.CIRCLIP	1	1	1	
4	2S2-15671-00	.WHEEL, RATCHET	1	1	1	
5	90501-160A2	.SPRING, COMPRESSION	1	1	1	
6	90201-167P7	.WASHER, PLATE	1	1	1	
7	99009-16400	.CIRCLIP	1	1	1	
8	5GR-15664-00	.GUIDE, SPRING	1	1	1	
9	90508-305B0	.SPRING, TORSION	1	1	1	
10	90201-162H4	WASHER, PLATE	1	1	1	
11	5SG-15668-00	STOPPER	1	1	1	
12	214-15686-00	WASHER, LOCK	1	1	1	
13	90101-06044	BOLT	2	2	2	
14	93102-20108	OIL SEAL	1	1	1	
15	5TA-15651-00	GEAR, KICK IDLE	1	1	1	
16	90201-20685	WASHER, PLATE (T=0.5)	1	1	1	
17	99009-20400	CIRCLIP	1	1	1	
18	2S2-15620-01	KICK CRANK ASSY	1	1	1	
19	5XD-15621-00	.BOSS, KICK CRANK	1	1	1	
20	90501-147A5	.SPRING, COMPRESSION	1	1	1	
21	93507-32009	.BALL	1	1	1	
22	90152-06010	.SCREW, COUNTERSUNK	1	1	1	
23	93210-17570	.O-RING	1	1	1	
24	90110-08087	BOLT, HEXAGON SOCKET HEAD	1	1	1	
25	90201-08047	WASHER, PLATE	1	1	1	



5TJE100-F160

FIG. 16 STARTER CLUTCH

REF. NO.	PART NO.	DESCRIPTION	1HB2	1HB3	1HB4	REMARKS
1	5TJ-15560-20	DAMPER ASSY	1	1	1	
2	90201-105A8	WASHER, PLATE	2	2	2	
3	93310-212R6	BEARING	1	1	1	
4	4GY-15521-00	SHAFT 1	1	1	1	
5	5TJ-15517-00	GEAR, IDLER 2	1	1	1	
6	5TG-15515-01	GEAR 3	1	1	1	
7	5UM-15570-00	STARTER CLUTCH ASSY	1	1	1	
8	5VY-15586-00	PLATE, STARTER CLUTCH ASSY	1	1	1	

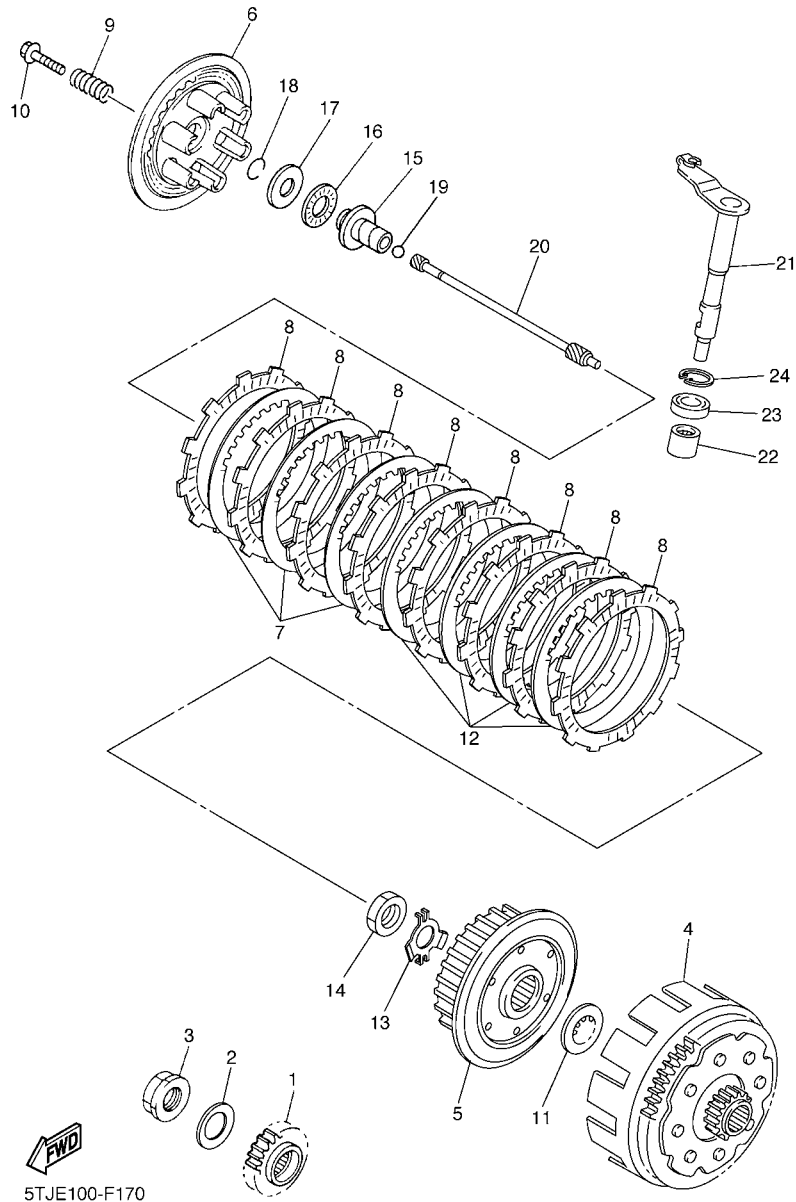

5TJE100-F170

FIG. 17 CLUTCH

REF. NO.	PART NO.	DESCRIPTION	1HB2	1HB3	1HB4	REMARKS
1	2S2-16111-60	GEAR, PRIMARY DRIVE	1	1	1	
2	90208-25045	WASHER, CONICAL SPRING	1	1	1	
3	90179-20009	NUT	1	1	1	
4	5XD-16150-60	PRIMARY DRIVEN GEAR COMP.	1	1	1	
5	5TA-16371-10	BOSS, CLUTCH	1	1	1	
6	5JG-16351-00	PLATE, PRESSURE 1	1	1	1	
7	4X7-16325-00	PLATE, CLUTCH 2	3	3	3	
8	5TA-16321-00	PLATE, FRICTION	8	8	8	
9	90501-237L0	SPRING, COMPRESSION	6	6	6	
10	90159-06092	SCREW, WITH WASHER	6	6	6	
11	5XD-16154-00	PLATE, THRUST 1	1	1	1	
12	1TA-16325-00	PLATE, CLUTCH 2	4	4	4	
13	90215-20005	WASHER, LOCK	1	1	1	
14	90170-20327	NUT	1	1	1	
15	5JG-16356-00	ROD, PUSH 1	1	1	1	
16	93340-21505	BEARING	1	1	1	
17	90201-125L6	WASHER, PLATE	1	1	1	
18	93440-10085	CIRCLIP	1	1	1	
19	93511-32027	BALL	1	1	1	
20	2S2-16357-00	ROD, PUSH 2	1	1	1	
21	5TJ-16381-20	PUSH LEVER COMP.	1	1	1	
22	93317-11287	BEARING	1	1	1	
23	93102-12224	OIL SEAL	1	1	1	
24	99009-20500	CIRCLIP	1	1	1	

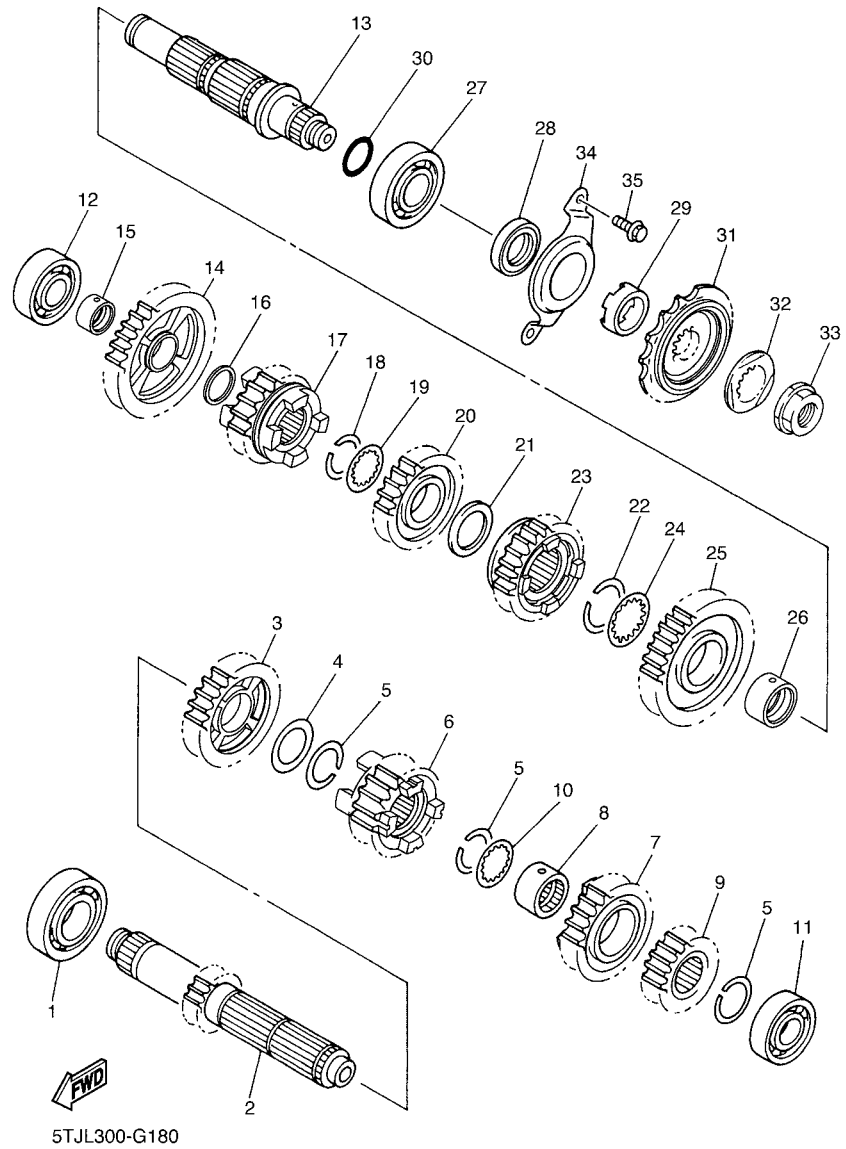

FIG. 18 TRANSMISSION

REF. NO.	PART NO.	DESCRIPTION	1HB2	1HB3	1HB4	REMARKS
1	93306-20532	BEARING	1	1	1	
2	5TJ-17411-20	AXLE,MAIN(12T)	1	1	1	
3	5TJ-17151-20	GEAR, 5TH PINION(25T)	1	1	1	
4	90201-253K0	WASHER, PLATE (T=1.0)	1	1	1	
5	93440-25084	CIRCLIP	3	3	3	
6	5TJ-17131-20	GEAR, 3RD PINION(16T)	1	1	1	
7	5TJ-17141-20	GEAR, 4TH PINION (20T)	1	1	1	
8	90387-21005	COLLAR	1	1	1	
9	5TJ-17121-20	GEAR, 2ND PINION(15T)	1	1	1	
10	90209-21332	WASHER	1	1	1	
11	93306-00431	BEARING	1	1	1	
12	93306-00426	BEARING	1	1	1	
13	2S2-17402-00	DRIVE AXLE ASSY	1	1	1	
14	5TJ-17211-20	GEAR, 1ST WHEEL(29T)	1	1	1	
15	90387-20028	COLLAR	1	1	1	
16	90201-203E7	WASHER, PLATE	1	1	1	
17	5TJ-17251-20	GEAR, 5TH WHEEL(21T)	1	1	1	
18	93440-25084	CIRCLIP	1	1	1	
19	90209-21332	WASHER	1	1	1	
20	5TJ-17231-20	GEAR, 3RD WHEEL(21T)	1	1	1	
21	90201-253K0	WASHER, PLATE (T=1.0)	1	1	1	
22	93440-28062	CIRCLIP	1	1	1	
23	5TJ-17241-20	GEAR, 4TH WHEEL(21T)	1	1	1	
24	90209-26348	WASHER	1	1	1	
25	5TJ-17221-20	GEAR, 2ND WHEEL(26T)	1	1	1	
26	90387-28012	COLLAR	1	1	1	
27	93306-205A5	BEARING	1	1	1	

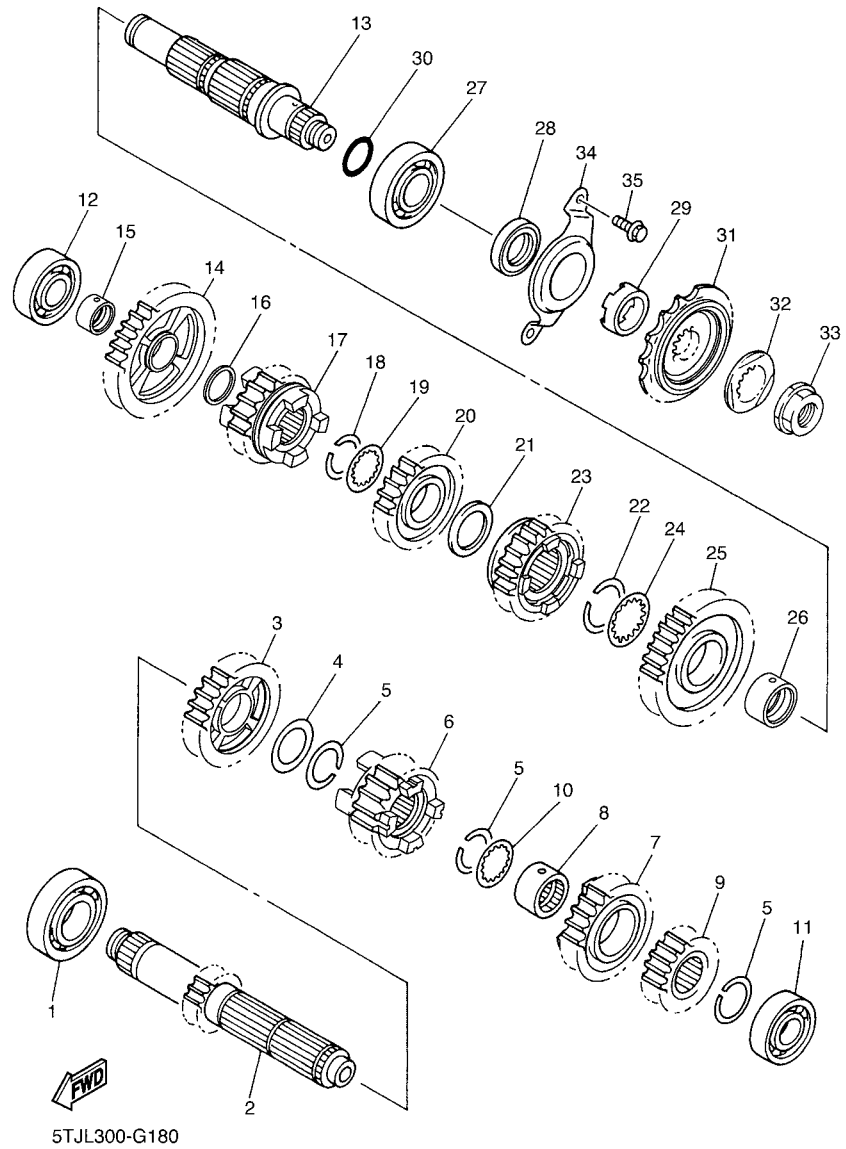
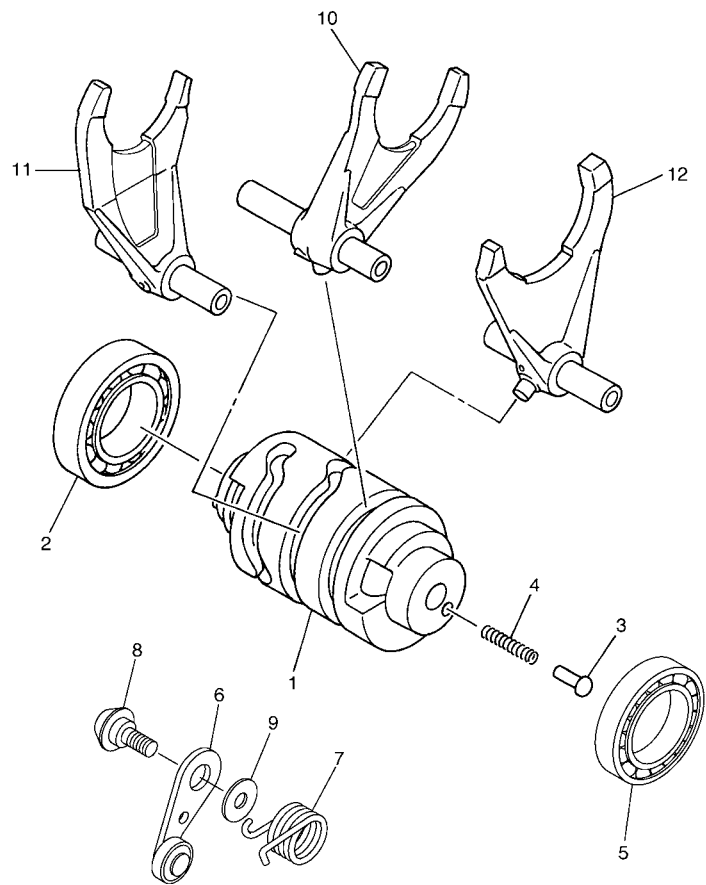

FIG. 18 TRANSMISSION

REF. NO.	PART NO.	DESCRIPTION	1HB2	1HB3	1HB4	REMARKS
28	93102-32480	OIL SEAL	1	1	1	
29	90387-2513F	COLLAR	1	1	1	
30	93210-22164	O-RING	1	1	1	
31	5TJ-17460-00	SPROCKET DRIVE(13T)	1			
	5NG-17460-00	SPROCKET, DRIVE (14T)		1		STD
	9383E-13233	SPROCKET, DRIVE (13T)		1		AP
	9383E-13233	SPROCKET, DRIVE (13T)			1	STD
	9383E-14215	SPROCKET, DRIVE (14T)			1	AP FOR OCE
32	90215-21003	WASHER, LOCK	1	1	1	
33	90179-20001	NUT	1	1	1	
34	2S2-17471-00	PLATE, COVER	1	1	1	
35	90105-06081	BOLT, FLANGE	2	2	2	



2S27100-F170

FIG. 19 SHIFT CAM & FORK

REF. NO.	PART NO.	DESCRIPTION	1HB2	1HB3	1HB4	REMARKS
1	5NL-18541-00	CAM, SHIFT	1	1	1	
2	93306-90509	BEARING	1	1	1	
3	278-18542-00	POINT, NEUTRAL	1	1	1	
4	90501-06022	SPRING, COMPRESSION	1	1	1	
5	93306-80502	BEARING	1	1	1	
6	2S2-18140-10	STOPPER LEVER ASSY	1	1	1	
7	90508-26021	SPRING, TORSION	1	1	1	
8	90109-06198	BOLT	1	1	1	
9	90201-06013	WASHER, PLATE	1	1	1	
10	34P-18501-00	FORK, SHIFT 1	1	1	1	
11	2S2-18502-00	FORK, SHIFT 2	1	1	1	
12	34P-18503-00	FORK, SHIFT 3	1	1	1	

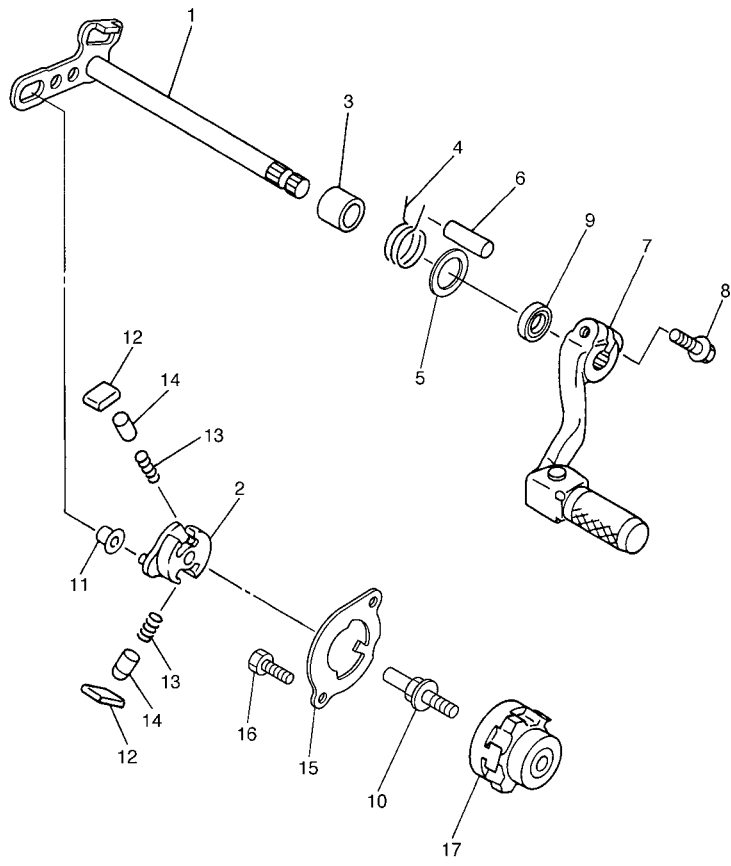
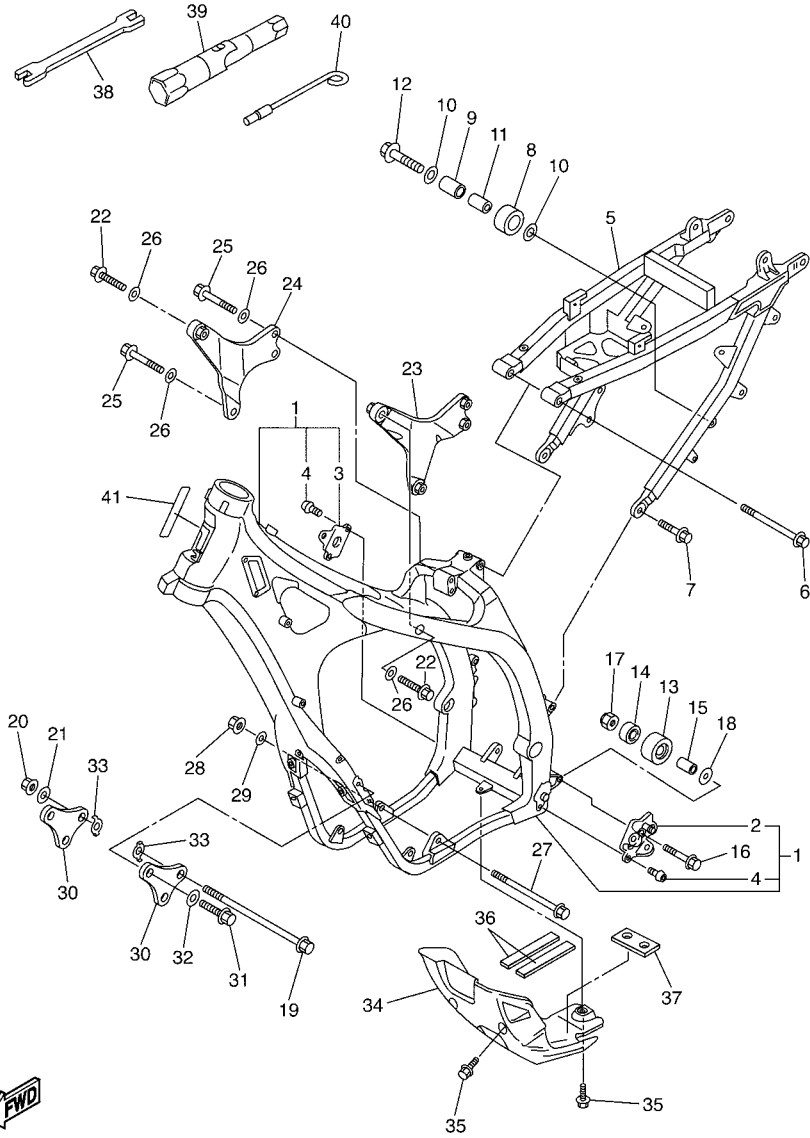

FIG. 20 SHIFT SHAFT

REF. NO.	PART NO.	DESCRIPTION	1HB2	1HB3	1HB4	REMARKS
1	2S2-18101-00	SHIFT SHAFT ASSY	1	1	1	
2	5MW-18122-01	LEVER, SHIFT 2	1	1	1	
3	90387-124F4	COLLAR	1	1	1	
4	90508-29021	SPRING, TORSION	1	1	1	
5	90201-127E1	WASHER, PLATE	1	1	1	
6	93608-33002	PIN, DOWEL	1	1	1	
7	5XC-18110-00	SHIFT PEDAL ASSY	1	1	1	
8	90105-06127	BOLT, FLANGE	1	1	1	
9	93102-12224	OIL SEAL	1	1	1	
10	3XJ-18173-10	PIN, SHIFT	1	1	1	
11	3XJ-18178-00	ROLLER, SHIFT LEVER	1	1	1	
12	3XJ-18182-00	PAWL, SHIFTER	2	2	2	
13	90501-052G5	SPRING, COMPRESSION	2	2	2	
14	3XJ-18184-00	PIN, PAWL	2	2	2	
15	5TJ-18172-00	GUIDE, SHIFT	1	1	1	
16	90101-06041	BOLT	2	2	2	
17	2S2-18185-00	SEGMENT	1	1	1	



2S21100-E180



5TJP100-H210

FIG. 21 FRAME

REF. NO.	PART NO.	DESCRIPTION	1HB2	1HB3	1HB4	REMARKS
1	5TJ-21101-E0	FRONT FRAME COMP.	1	1	1	
2	5UM-21447-E0	.BRACKET, FOOTREST	1	1	1	
3	1C3-21448-10	.BRACKET, FOOTREST	1	1	1	
4	90149-10031	.SCREW	4	4	4	
5	5UM-21190-E0	REAR FRAME COMP.	1	1	1	
6	90105-08156	BOLT, FLANGE	1	1	1	
7	90105-08307	BOLT, FLANGE	2	2	2	
8	30X-22178-00	TENSIONER	1	1	1	
9	4V4-22184-00	BUSH	1	1	1	
10	90201-08045	WASHER, PLATE	2	2	2	
11	90387-08041	COLLAR	1	1	1	
12	95022-08040	BOLT, FLANGE	1	1	1	
13	3JD-22178-20	TENSIONER	1	1	1	
14	93300-60839	BEARING	1	1	1	
15	90387-086N4	COLLAR	1	1	1	
16	90105-08133	BOLT, FLANGE	1	1	1	
17	90185-08009	NUT, SELF-LOCKING	1	1	1	
18	90201-08043	WASHER, PLATE	1	1	1	
19	90105-10193	BOLT, FLANGE	1	1	1	
20	90179-10658	NUT	1	1	1	
21	90201-10045	WASHER, PLATE	1	1	1	
22	90105-10189	BOLT, FLANGE	2	2	2	
23	2S2-21425-70	BRACKET, REAR UPPER 1	1	1	1	
24	2S2-21426-70	BRACKET, REAR UPPER 2	1	1	1	
25	90105-10191	BOLT, FLANGE	3	3	3	
26	90201-10045	WASHER, PLATE	5	5	5	
27	90105-10176	BOLT, FLANGE	1	1	1	

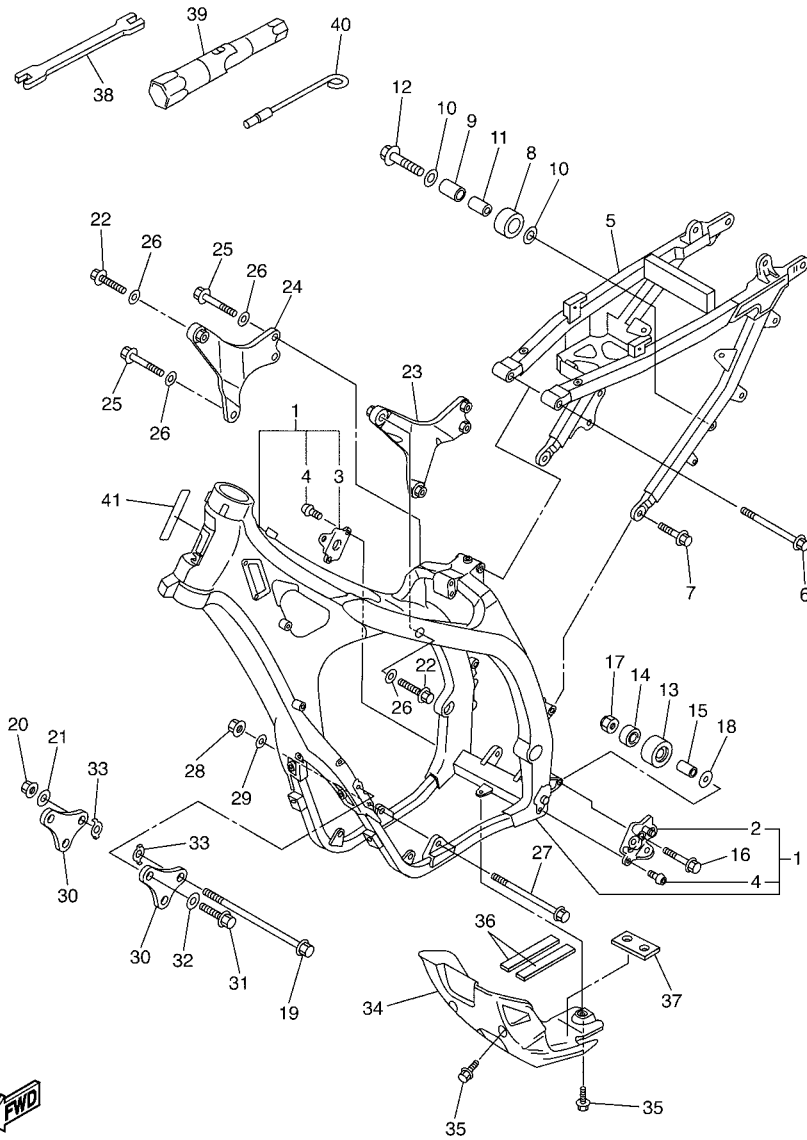

5TJP100-H210

FIG. 21 FRAME

REF. NO.	PART NO.	DESCRIPTION	1HB2	1HB3	1HB4	REMARKS
28	90179-10658	NUT	1	1	1	
29	90201-10045	WASHER, PLATE	1	1	1	
30	2S2-21417-00	BRACKET, FRONT LOWER 1	2	2	2	
31	90105-08143	BOLT, FLANGE	4	4	4	
32	92902-08200	WASHER	4	4	4	
33	5XC-21456-90	PLATE, PATCH	2	2	2	
34	5UM-2147A-E0	GUARD, ENGINE 1	1	1	1	
35	90119-06166	BOLT, WITH WASHER	3	3	3	
36	5UM-21486-E0	DAMPER 2	2	2	2	
37	5TJ-21485-E0	DAMPER, RUBBER 1	1	1	1	
38	5ET-28166-10	WRENCH, HEXAGON	1	1	1	
39	5TA-2814F-00	BOX, SPARK PLUG	1	1	1	
40	5XC-28116-00	TOOL, SPECIAL		1	1	
41	5UM-21268-E0	SEAL	1	1	1	

FIG. 22 FENDER

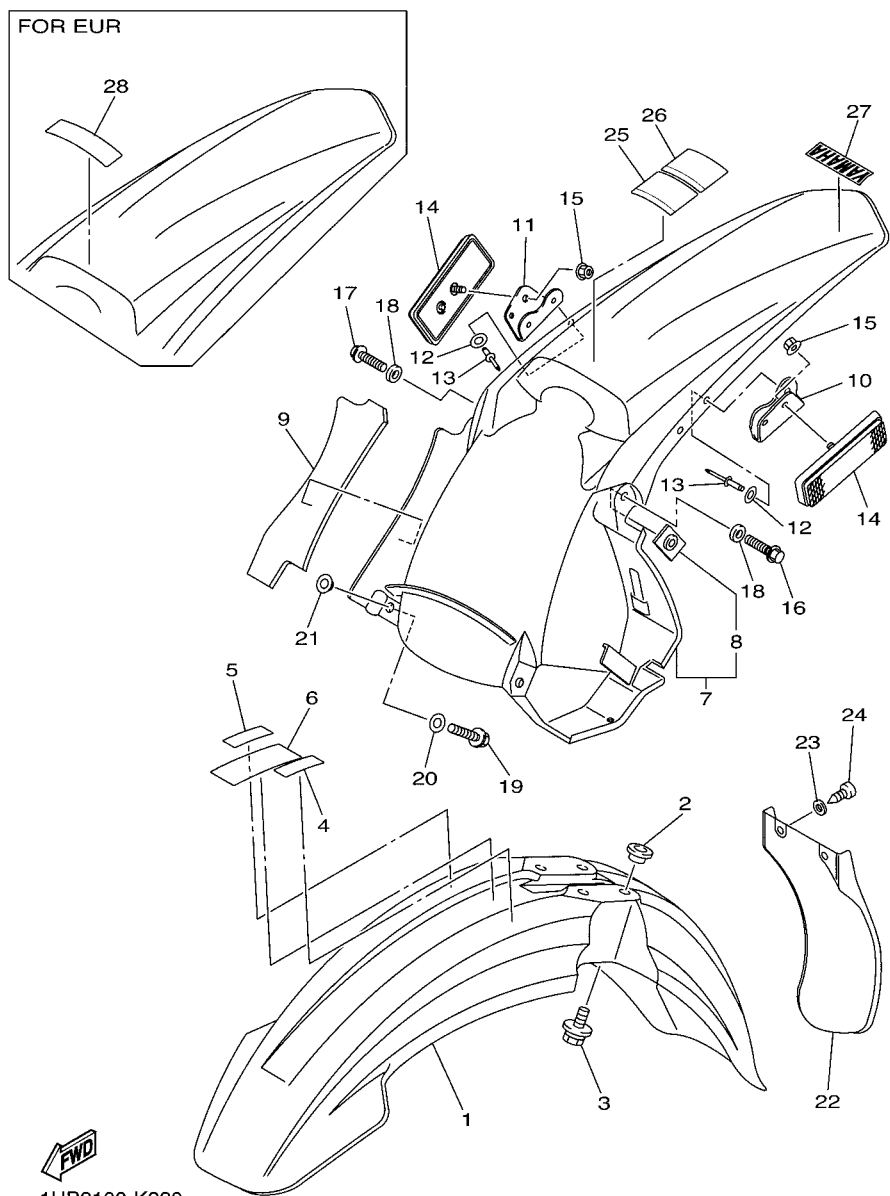

REF. NO.	PART NO.	DESCRIPTION	1HB2	1HB3	1HB4	REMARKS
1	1C3-21511-51	FENDER, FRONT	1	1	1	
2	90387-06090	COLLAR	4	4	4	
3	90119-06147	BOLT, WITH WASHER	4	4	4	
4	3FB-2415E-02	LABEL, CAUTION	1			
5	3FB-2415E-12	LABEL, CAUTION	1			
6	3PT-2416E-10	LABEL, CAUTION CANADA	1			
7	5TJ-21610-U0	REAR FENDER COMP.	1			
	5UM-21610-E0	REAR FENDER COMP.		1	1	
8	5XE-21635-10	.NUT, REAR FENDER	2	2	2	
9	5UM-2174T-E0	INSULATOR, SIDE COVER 2	1	1	1	
10	5TJ-2164F-U0	STAY 1	1			
11	5TJ-2164G-U0	STAY 2	1			
12	90201-04018	WASHER, PLATE	4			
13	90267-40129	RIVET, BLIND	4			
14	3Y6-85130-02	REAR REFLECTOR ASSY	2			
15	95602-05200	NUT, SELF-LOCKING	2			
16	90105-06127	BOLT, FLANGE	1	1	1	
17	90105-06100	BOLT, FLANGE	1	1	1	
18	90201-06032	WASHER, PLATE	2	2	2	
19	90105-06106	BOLT, FLANGE	2	2	2	
20	90201-06571	WASHER, PLATE	2	2	2	
21	90387-06009	COLLAR	2	2	2	
22	5TA-21642-00	GUARD, FLAP	1	1	1	
23	90201-06084	WASHER, PLATE	2	2	2	
24	97702-60016	SCREW, TAPPING	2	2	2	
25	5PA-2118K-00	LABEL, CAUTION	1		1	
26	5PA-2118K-10	LABEL, CAUTION	1			

FIG. 23 SIDE COVER

REF. NO.	PART NO.	DESCRIPTION	1HB2	1HB3	1HB4	REMARKS
1	5UM-21711-E0	COVER, SIDE 1	1	1	1	
4	5UM-21717-E0	DAMPER	1	1	1	
5	90105-06103	BOLT, FLANGE	1	1	1	
6	90119-08095	BOLT, WITH WASHER	1	1	1	
7	5UM-21721-E0	COVER, SIDE 2	1	1	1	
10	5UM-2174A-E0	INSULATOR, SIDE COVER	1	1	1	
11	5XC-21719-90	GROMMET	2	2	2	
12	5UM-2172S-E0	INSULATOR 3	1	1	1	
13	5UM-2173S-E0	INSULATOR 4	1	1	1	
14	90105-06103	BOLT, FLANGE	1	1	1	
15	90119-08095	BOLT, WITH WASHER	1	1	1	
16	5UM-21730-E0	SIDE COVER ASSY 3	1	1	1	
20	1HB-2173E-00	GRAPHIC, 1	1	1	1	
21	1HB-2174G-00	GRAPHIC, 3	1	1	1	
22	1HB-2174J-00	GRAPHIC, 5	1	1	1	
23	90105-06064	BOLT, FLANGE	4	4	4	
24	5TJ-2172A-E0	PANEL 1	1	1	1	
25	5UM-21740-E0	SIDE COVER ASSY 4	1	1	1	
29	1HB-2173F-00	GRAPHIC, 2	1	1	1	
30	1HB-2174H-00	GRAPHIC, 4	1	1	1	
31	1HB-2174K-00	GRAPHIC, 6	1	1	1	
32	90105-06064	BOLT, FLANGE	4	4	4	
33	2S2-2172A-80	PANEL 1	1	1	1	
34	5UM-21860-E0	TANK ASSY	1	1	1	
35	26H-21875-00	CAP	1	1	1	
36	26H-21874-00	GASKET	1	1	1	
37	90119-06146	BOLT, WITH WASHER	1	1	1	

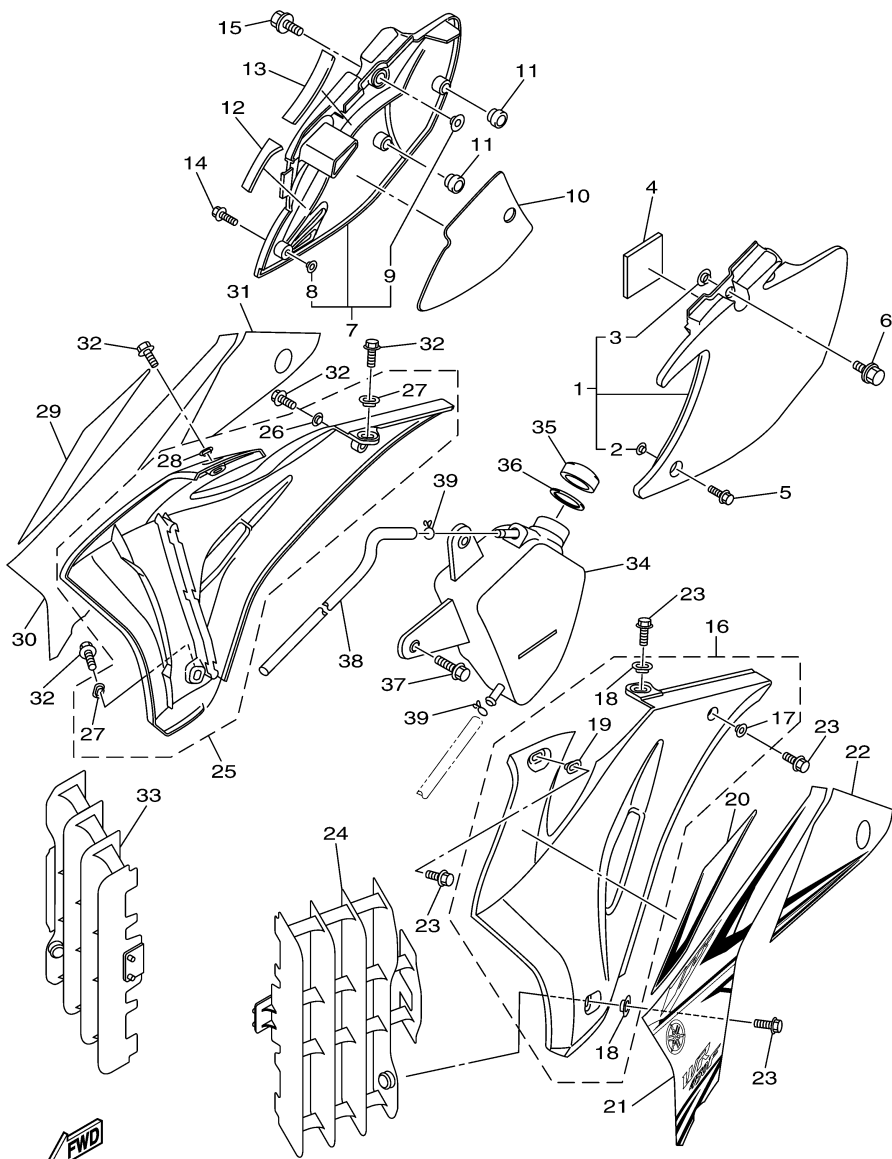

1HB1110-K231

FIG. 23 SIDE COVER

REF. NO.	PART NO.	DESCRIPTION	1HB2	1HB3	1HB4	REMARKS
38	5UM-1244J-E0	HOSE 6	1	1	1	
39	90467-090A2	CLIP	2	2	2	
2	90387-06009	.COLLAR	1	1	1	
3	5BE-21749-00	.COLLAR	1	1	1	
8	90387-06009	.COLLAR	1	1	1	
9	5BE-21749-00	.COLLAR	1	1	1	
17	90387-06009	.COLLAR	1	1	1	
18	5TA-21749-00	.COLLAR	2	2	2	
19	5XC-21749-90	.COLLAR	1	1	1	
26	90387-06009	.COLLAR	1	1	1	
27	5TA-21749-00	.COLLAR	2	2	2	
28	5XC-21749-90	.COLLAR	1	1	1	

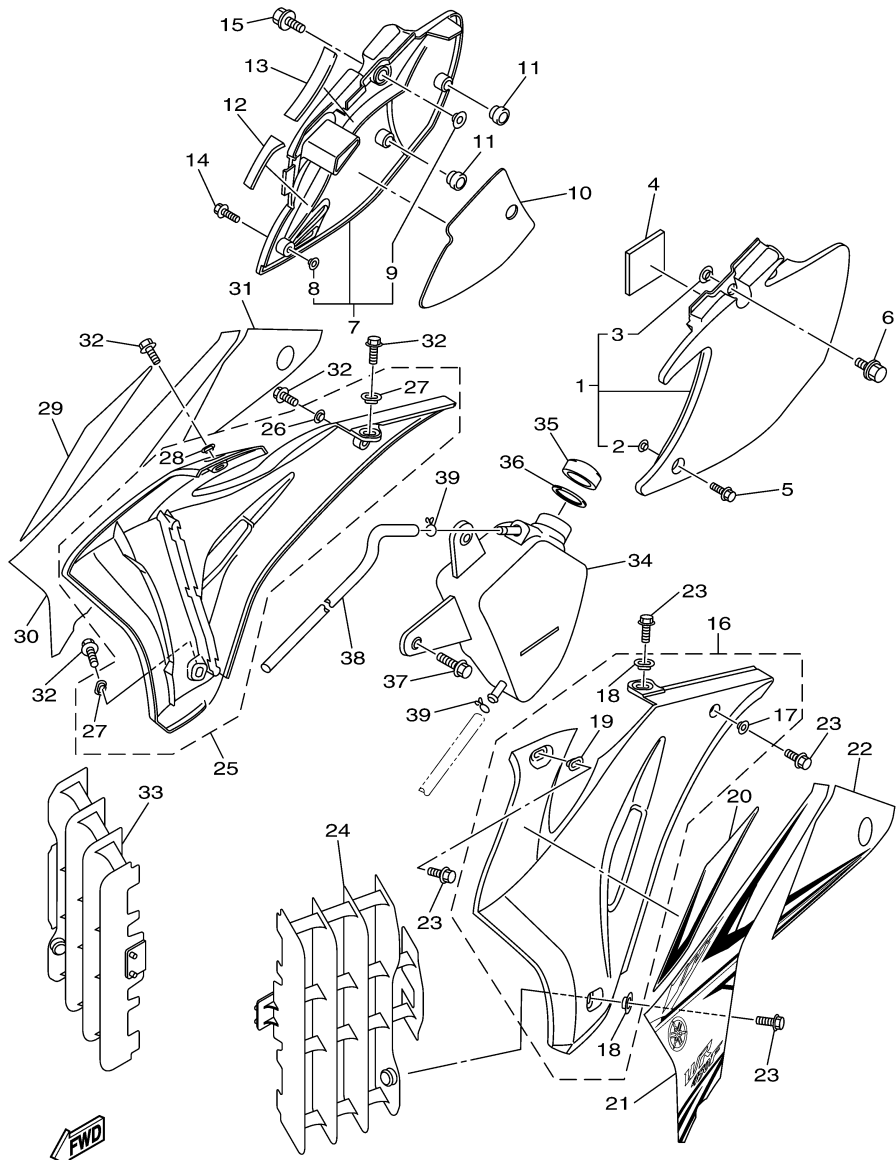

1HB1110-K231

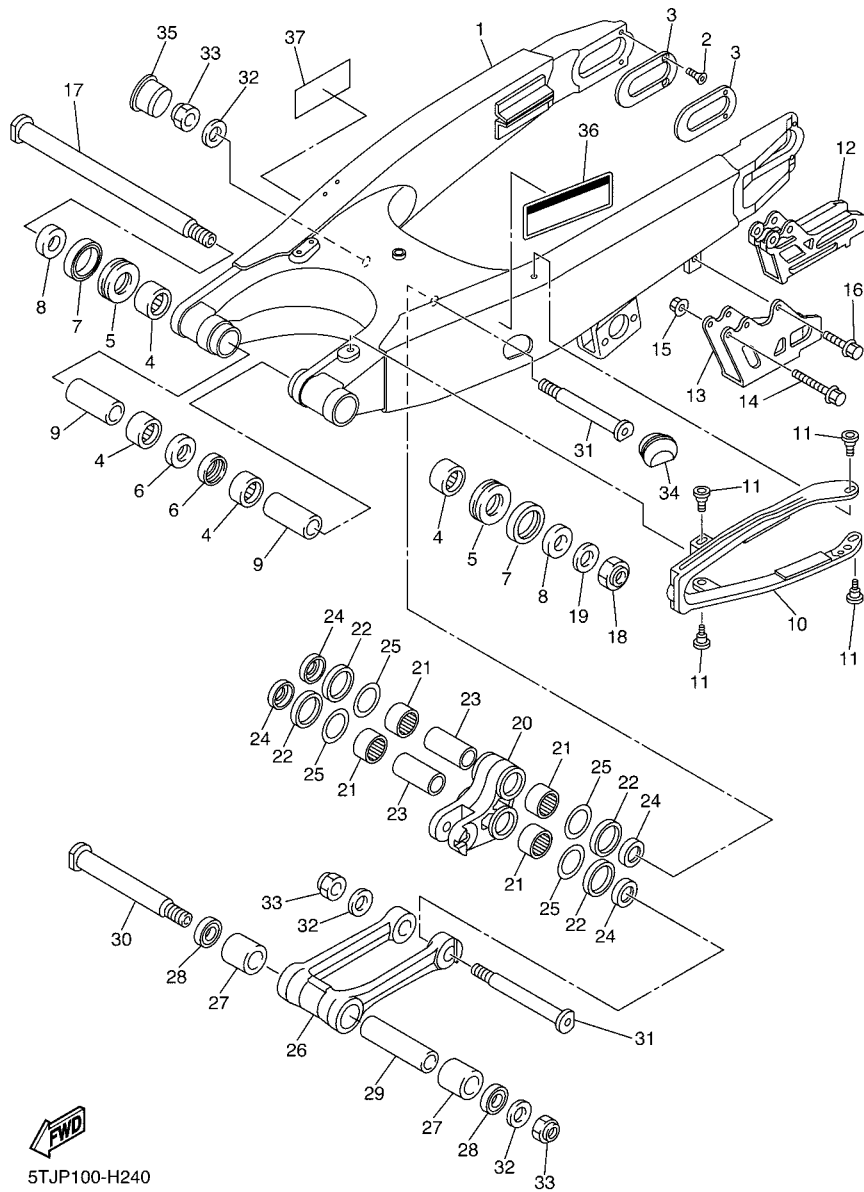

5TJP100-H240

FIG. 24 REAR ARM

REF. NO.	PART NO.	DESCRIPTION	1HB2	1HB3	1HB4	REMARKS
1	1C3-22110-90	REAR ARM COMP.	1	1	1	
2	90151-04003	SCREW, COUNTERSUNK	4	4	4	
3	1P8-22355-00	PATCH	2	2	2	
4	93317-22262	BEARING	4	4	4	
5	93342-22217	BEARING	2	2	2	
6	93106-22002	OIL SEAL	2	2	2	
7	93109-28043	OIL SEAL	2	2	2	
8	90387-18012	COLLAR	2	2	2	
9	90387-18004	COLLAR	2	2	2	
10	2S2-22151-70	SEAL, GUARD	1	1	1	
11	1C3-22969-90	SCREW, 1	4	4	4	
12	5UM-22199-E0	SUPPORT, CHAIN	1	1	1	
13	2S2-22128-70	COVER, THRUST 1	1	1	1	
14	90105-06104	BOLT, FLANGE	2	2	2	
15	90179-06028	NUT	2	2	2	
16	90105-06105	BOLT, FLANGE	1	1	1	
17	1C3-22141-10	SHAFT, PIVOT	1	1	1	
18	90185-16002	NUT, SELF-LOCKING	1	1	1	
19	90201-16018	WASHER, PLATE	1	1	1	
20	5XC-2217A-90	ARM, RELAY	1	1	1	
21	93315-32166	BEARING	4	4	4	
22	93109-25001	OIL SEAL	4	4	4	
23	90387-16025	COLLAR	2	2	2	
24	90209-16011	WASHER	4	4	4	
25	90201-21014	WASHER, PLATE	4	4	4	
26	5XC-2217F-90	ROD, CONNECTING 1	1	1	1	
27	93315-32269	BEARING	2	2	2	

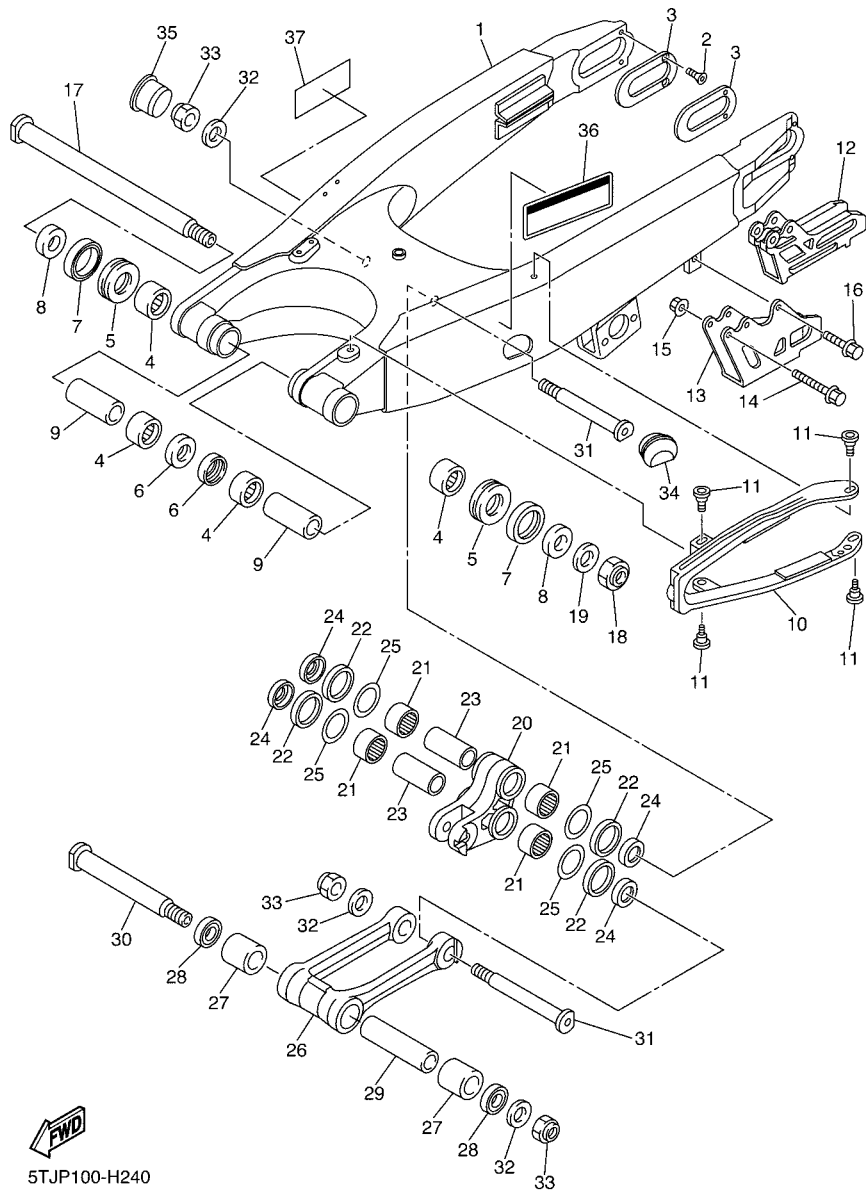

5TJP100-H240

FIG. 24 REAR ARM

REF. NO.	PART NO.	DESCRIPTION	1HB2	1HB3	1HB4	REMARKS
28	93109-22019	OIL SEAL	2	2	2	
29	90387-14009	COLLAR	1	1	1	
30	5XC-22121-91	SHAFT 1	1	1	1	
31	1C3-22122-00	SHAFT 2	2	2	2	
32	90201-14020	WASHER, PLATE	3	3	3	
33	90185-14010	NUT, SELF-LOCKING	3	3	3	
34	1C3-2135F-00	COVER	1	1	1	
35	1C3-2139R-00	COVER 2	1	1	1	
36	3RV-21668-A0	LABEL, TIRE	1	1		
37	3RV-21668-B0	LABEL, TIRE	1			

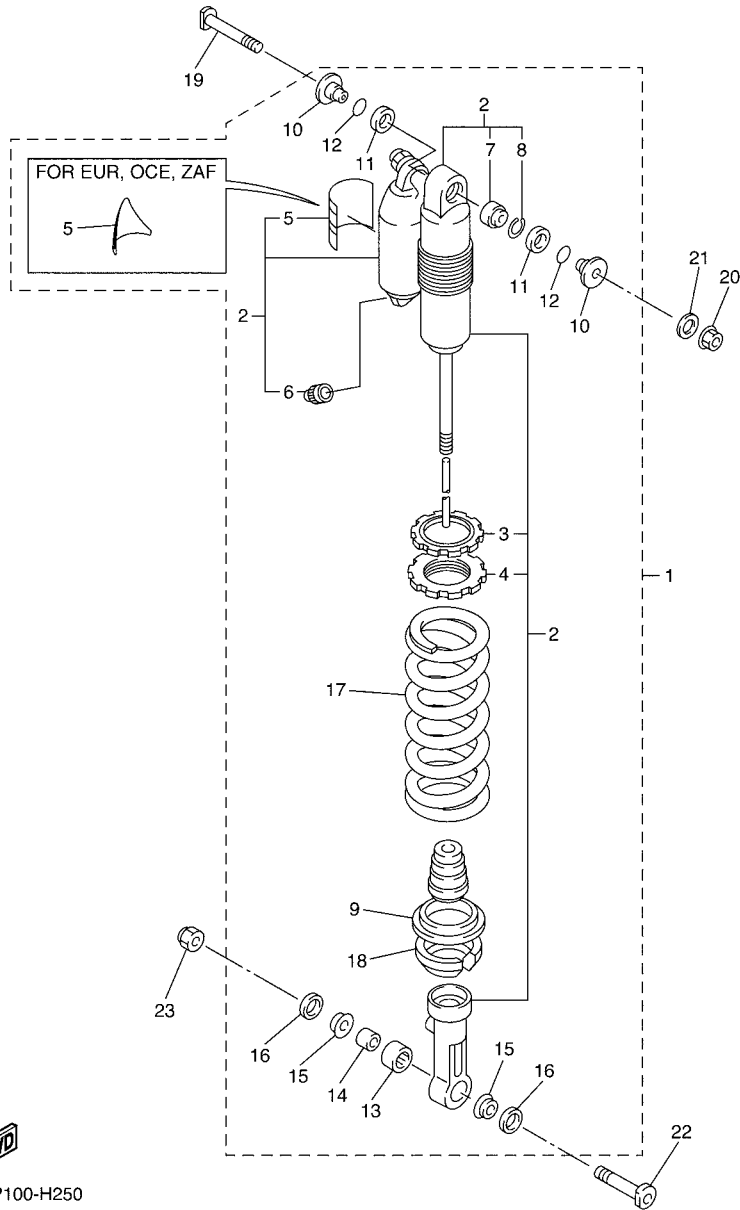

5TJP100-H250

FIG. 25 REAR SUSPENSION

REF. NO.	PART NO.	DESCRIPTION	1HB2	1HB3	1HB4	REMARKS
1	5TJ-22210-21	SHOCK ABSORBER ASSY, REAR	1			
	5TJ-22210-F1	SHOCK ABSORBER ASSY, REAR		1		
	5TJ-22210-G1	SHOCK ABSORBER ASSY, REAR			1	
2	5TJ-22201-20	.DAMPER SUB ASSY	1			
	5TJ-22201-F0	.DAMPER SUB ASSY		1		
	5TJ-22201-G0	.DAMPER SUB ASSY			1	
3	3SP-22234-00	..GUIDE, SPRING 3	1	1	1	
4	3SP-22213-00	..SEAT, SPRING UPPER	1	1	1	
5	4AA-22259-60	..LABEL, WARNING	1			
	4AA-22259-40	..LABEL, WARNING		1	1	
6	509-23184-L0	..CAP, AIR VALVE	1	1	1	
7	4JX-22226-00	..BUSH, SHOCK ABSORBER LOWER	1	1	1	
8	5DH-23183-00	..CIRCLIP	1	1	1	
9	5MV-22224-00	.GUIDE, SPRING 2	1	1	1	
10	1C3-22253-50	.COLLAR, DISTANCE	2	2	2	
11	3JE-22475-00	.SEAL, DUST	2	2	2	
12	4EW-22474-00	.SEAL, RING	2	2	2	
13	5UN-22176-00	.BEARING	1	1	1	
14	5MV-22184-00	.BUSH	1	1	1	
15	5MV-22253-00	.COLLAR, DISTANCE	2	2	2	
16	5NY-22475-00	.SEAL, DUST	2	2	2	
17	5UN-22212-60	.SPRING (K=54N/MM)	1	1	1	
18	5XE-22214-00	.GUIDE, SPRING 1	1	1	1	
19	5XE-22242-00	BOLT 2	1	1	1	
20	95602-10200	NUT, U FLANGE	1	1	1	
21	92902-10200	WASHER	1	1	1	
22	5NY-22241-00	BOLT 1	1	1	1	

FIG. 26 STEERING

REF. NO.	PART NO.	DESCRIPTION	1HB2	1HB3	1HB4	REMARKS
1	93332-00081	BEARING	1	1	1	
2	93332-00068	BEARING	1	1	1	
3	4EW-23416-00	COVER, BALL RACE 2	1	1	1	
4	90179-28013	NUT	1	1	1	
5	90201-286K9	WASHER, PLATE (T1.0)	1	1	1	
6	5UM-23435-E1	CROWN, HANDLE	1	1	1	
7	90170-24003	NUT	1	1	1	
8	90201-24016	WASHER, PLATE	1	1	1	
9	18P-23441-00	HOLDER, HANDLE UPPER	2	2	2	
10	17D-23442-00	HOLDER, HANDLE LOWER	2	2	2	
11	92902-10200	WASHER	2	2	2	
12	95602-10200	NUT, U FLANGE	2	2	2	
13	90105-08154	BOLT, FLANGE	4	8	8	
14	90105-08134	BOLT, FLANGE	4			
15	5UM-2831V-E0	STAY, HEAD LIGHT 1	1	1	1	
16	5TJ-2331E-80	GUIDE, CABLE	1	1	1	
17	90105-05016	BOLT, FLANGE	1	1	1	
18	5TJ-23389-80	GUIDE, CABLE	1	1	1	
19	90105-06107	BOLT, FLANGE	1	1	1	
20	90387-06104	COLLAR	1	1	1	
21	5TJ-2317E-U0	STAY 1	2			
22	4AG-85111-00	REFLECTOR, 1	2			
23	95602-06200	NUT, SELF-LOCKING	2			

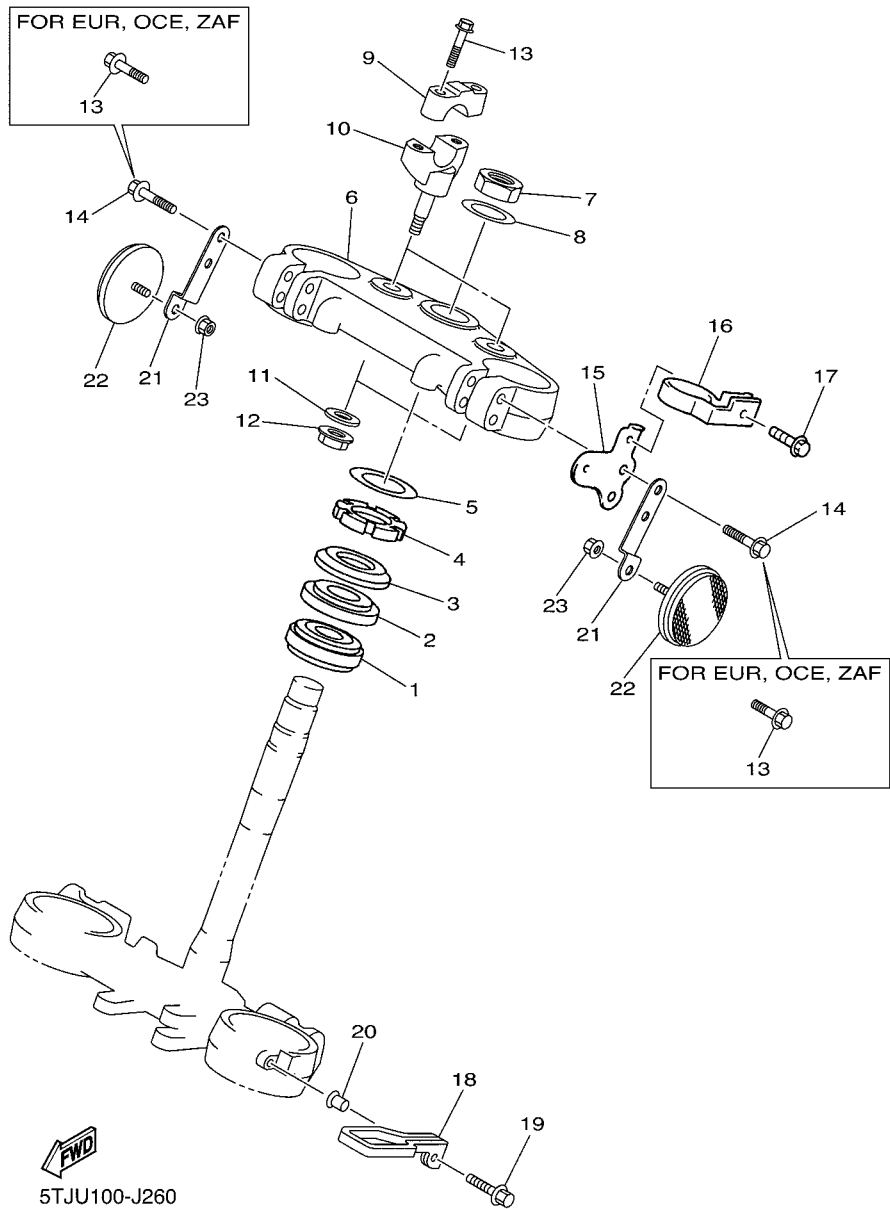

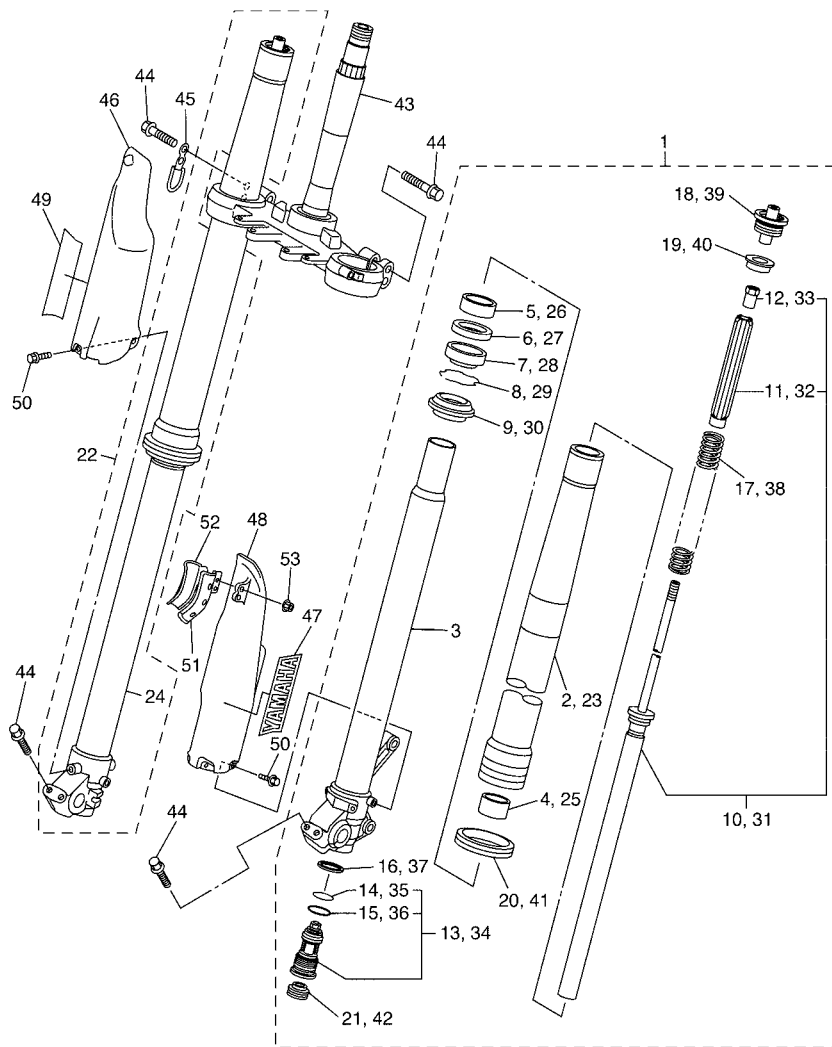

5TJP100-H270

FIG. 27 FRONT FORK

REF. NO.	PART NO.	DESCRIPTION	1HB2	1HB3	1HB4	REMARKS
1	5TJ-23102-E0	FRONT FORK ASSY (L.H)	1			
	5TJ-23102-F0	FRONT FORK ASSY (L.H)		1	1	
2	5TJ-23136-C0	.TUBE, OUTER	1	1	1	
3	5TJ-23120-C0	.INNER TUBE COMP.2	1	1	1	
4	5XE-23171-L0	.PISTON, FRONT FORK	1	1	1	
5	5XE-23125-L0	.METAL, SLIDE 1	1	1	1	
6	5XE-23146-L0	.WASHER, OIL SEAL	1	1	1	
7	1C3-23145-L0	.OIL SEAL	1	1	1	
8	5XE-23153-L0	.RING, SNAP	1	1	1	
9	5XE-23144-L0	.SEAL, DUST	1	1	1	
10	5UM-23170-E0	.CYLINDER COMP., FRONT FORK	1	1	1	
11	5XE-23142-L0	..SEAT, SPRING UPPER	1	1	1	
12	5XE-23393-L0	..NUT, SPECIAL	1	1	1	
13	5TJ-2316A-F0	.VALVE COMP.	1	1	1	
14	5NY-23188-L0	..O-RING	1	1	1	
15	5NY-23147-L0	..O-RING	1	1	1	
16	4SS-23158-L0	.GASKET	1	1	1	
17	5TJ-23141-L0	.SPRING,FRONT FORK(K=4.5N/MM)	1	1	1	
18	5XE-23111-L0	.BOLT, CAP	1	1	1	
19	5XE-23117-L0	.GUIDE, SPRING	1	1	1	
20	1C3-2314F-M0	.PROTECTOR GUIDE COMP., 1	1	1	1	
21	3JD-2312G-L0	.PLUG	1	1	1	
22	5TJ-23103-E0	FRONT FORK ASSY (R.H)	1			
	5TJ-23103-F0	FRONT FORK ASSY (R.H)		1	1	
23	5TJ-23136-C0	.TUBE, OUTER	1	1	1	
24	5TJ-23110-C0	.INNER TUBE COMP.1	1	1	1	
25	5XE-23171-L0	.PISTON, FRONT FORK	1	1	1	

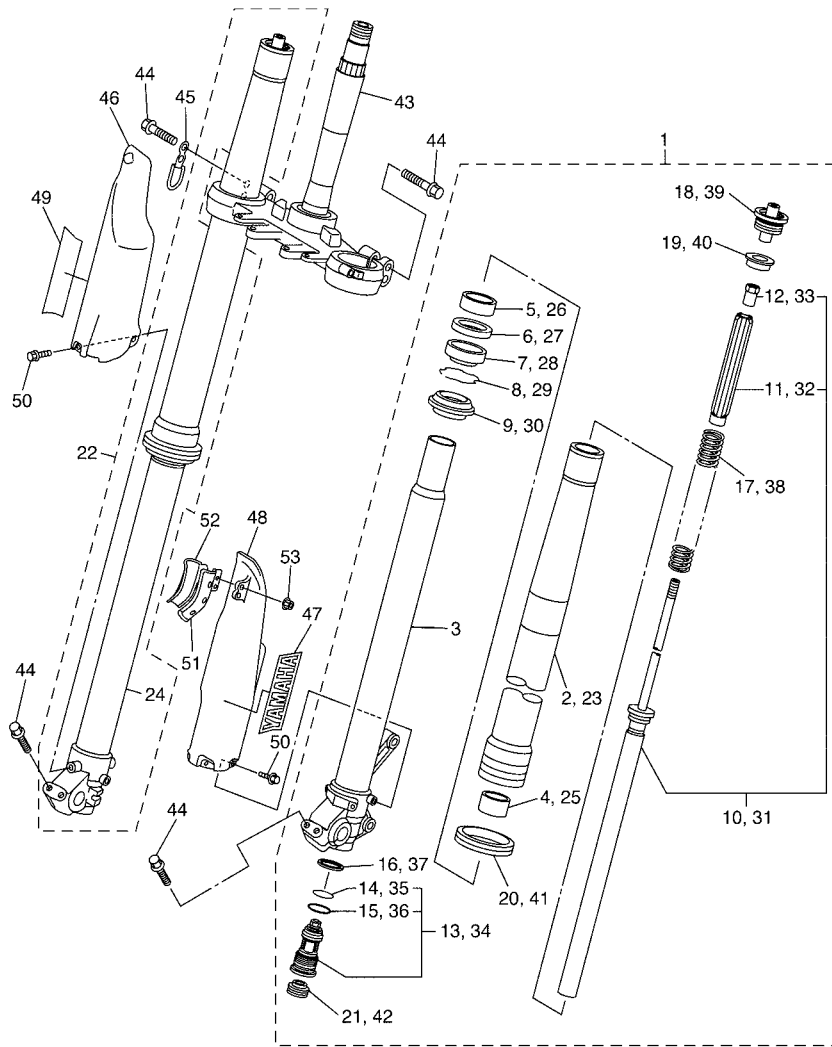

5TJP100-H270

FIG. 27 FRONT FORK

REF. NO.	PART NO.	DESCRIPTION	1HB2	1HB3	1HB4	REMARKS
26	5XE-23125-L0	.METAL, SLIDE 1	1	1	1	
27	5XE-23146-L0	.WASHER, OIL SEAL	1	1	1	
28	1C3-23145-L0	.OIL SEAL	1	1	1	
29	5XE-23153-L0	.RING, SNAP	1	1	1	
30	5XE-23144-L0	.SEAL, DUST	1	1	1	
31	5UM-23170-E0	.CYLINDER COMP., FRONT FORK	1	1	1	
32	5XE-23142-L0	..SEAT, SPRING UPPER	1	1	1	
33	5XE-23393-L0	..NUT, SPECIAL	1	1	1	
34	5TJ-2316A-F0	.VALVE COMP.	1	1	1	
35	5NY-23188-L0	..O-RING	1	1	1	
36	5NY-23147-L0	..O-RING	1	1	1	
37	4SS-23158-L0	.GASKET	1	1	1	
38	5TJ-23141-L0	.SPRING, FRONT FORK (K=4.5N/MM)	1	1	1	
39	5XE-23111-L0	.BOLT, CAP	1	1	1	
40	5XE-23117-L0	.GUIDE, SPRING	1	1	1	
41	1C3-2314F-M0	.PROTECTOR GUIDE COMP., 1	1	1	1	
42	3JD-2312G-L0	.PLUG	1	1	1	
43	5TJ-23340-M0	UNDER BRACKET COMP.	1	1	1	
44	90105-08134	BOLT, FLANGE	8	8	8	
45	5TJ-23525-C0	GUIDE	1	1	1	
46	5TJ-2315J-C0	PROTECTOR 2	1	1	1	
47	4XL-2153A-10	EMBLEM, YAMAHA	1	1	1	
48	1C3-2315H-10	PROTECTOR 1	1	1	1	
49	4XL-2153A-10	EMBLEM, YAMAHA	1	1	1	
50	3SP-23356-L0	BOLT 2	6	6	6	
51	5XC-23466-L0	CLAMP	1	1	1	
52	5XC-23467-L0	CLAMP	1	1	1	

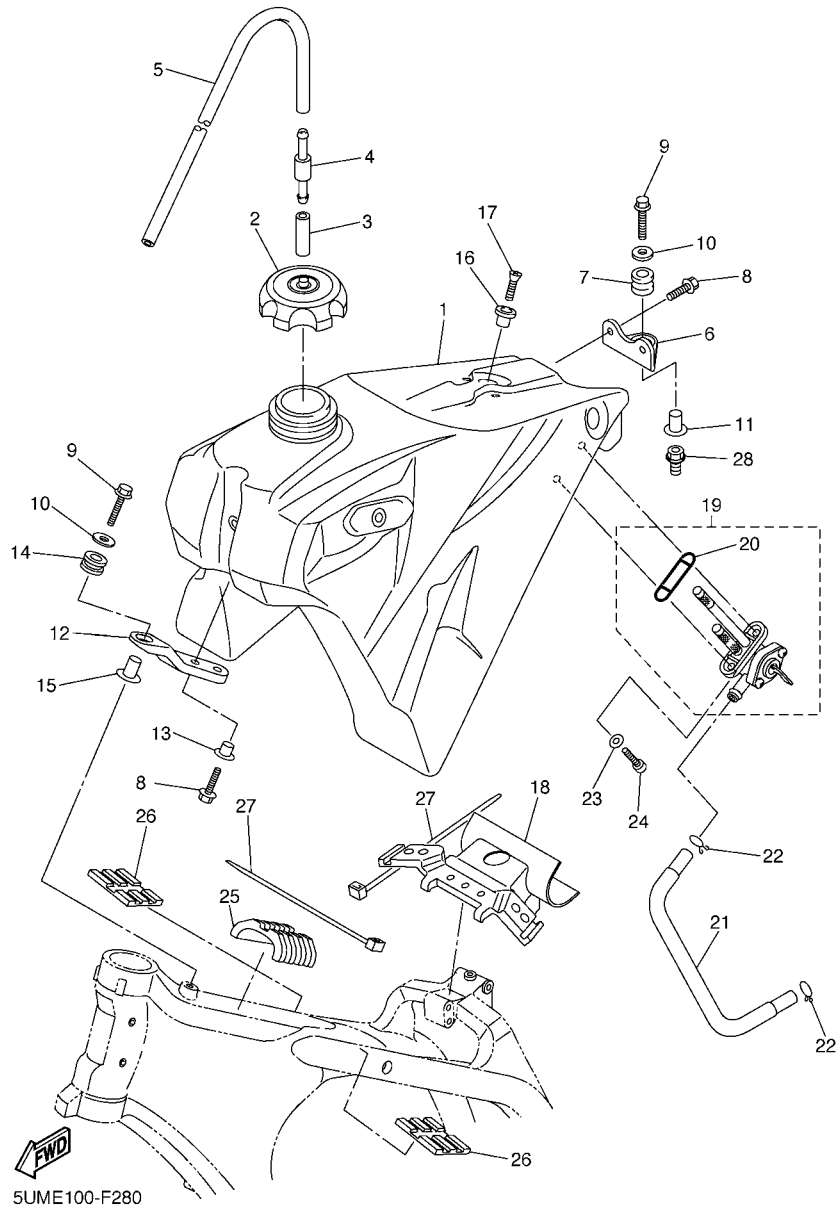

FIG. 28 FUEL TANK

REF. NO.	PART NO.	DESCRIPTION	1HB2	1HB3	1HB4	REMARKS
1	5TJ-24110-J0	FUEL TANK COMP.	1			
	5UM-24110-E1	FUEL TANK COMP.		1	1	
2	5NY-24610-00	CAP ASSY	1	1	1	
3	90445-09027	HOSE (L30)	1			
	90445-09220	HOSE (L30)		1	1	
4	3XJ-24380-00	PIPE JOINT ASSY	1	1	1	
5	90445-09251	HOSE (L350)	1	1	1	
6	5XE-24144-00	HOLDER, DAMPER	1	1	1	
7	90480-18549	GROMMET	1	1	1	
8	90105-06107	BOLT, FLANGE	4	4	4	
9	90105-06111	BOLT, FLANGE	2	2	2	
10	90201-06570	WASHER, PLATE	2	2	2	
11	3JD-24186-00	WASHER, SPECIAL	1	1	1	
12	5XC-2419A-90	HOLDER	1	1	1	
13	90387-06090	COLLAR	2	2	2	
14	5XC-24339-90	GROMMET	1	1	1	
15	90387-06065	COLLAR	1	1	1	
16	4EW-2412F-00	BRACKET, SEAT	1	1	1	
17	98702-06025	SCREW, FLAT HEAD	1	1	1	
18	5UM-24181-E0	DAMPER, LOCATING 1	1	1	1	
19	5UM-24500-E0	FUEL COCK ASSY 1	1	1	1	
20	1P6-24512-00	.GASKET	1	1	1	
21	5TJ-24311-J0	PIPE, FUEL 1	1			
	5TJ-24311-E0	PIPE, FUEL 1		1	1	
22	90467-100A1	CLIP	2	2	2	
23	90202-05193	WASHER, PLATE	2	2	2	
24	90149-06108	SCREW	2	2	2	

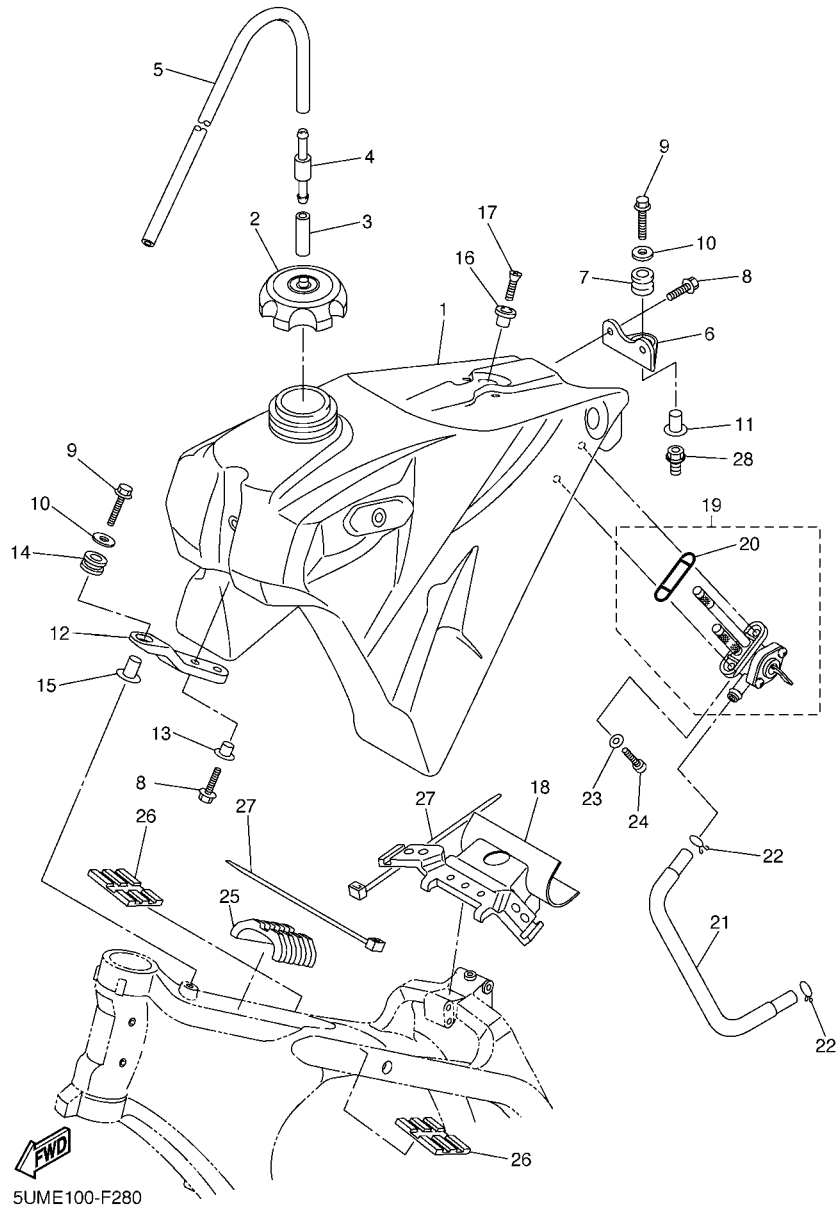
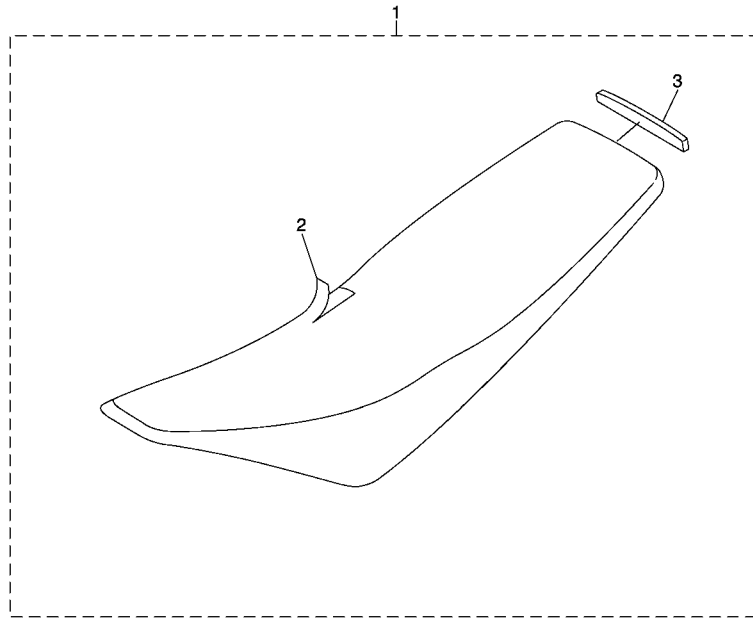

FIG. 28 FUEL TANK

REF. NO.	PART NO.	DESCRIPTION	1HB2	1HB3	1HB4	REMARKS
25	5XC-24182-90	DAMPER, LOCATING 2	1	1	1	
26	5XC-24183-90	DAMPER, LOCATING 3	2	2	2	
27	90465-13275	CLAMP	3	3	3	
28	1C3-21244-10	NUT	1	1	1	

FIG. 29 SEAT



REF. NO.	PART NO.	DESCRIPTION	1HB2	1HB3	1HB4	REMARKS
1	5UM-24710-T0	SINGLE SEAT ASSY	1	1	1	
2	5UM-2470F-T0	.SEAT COVER COMP.	1	1	1	
3	5UM-24723-E0	.DAMPER, SEAT	1	1	1	

 5TJE100-F290

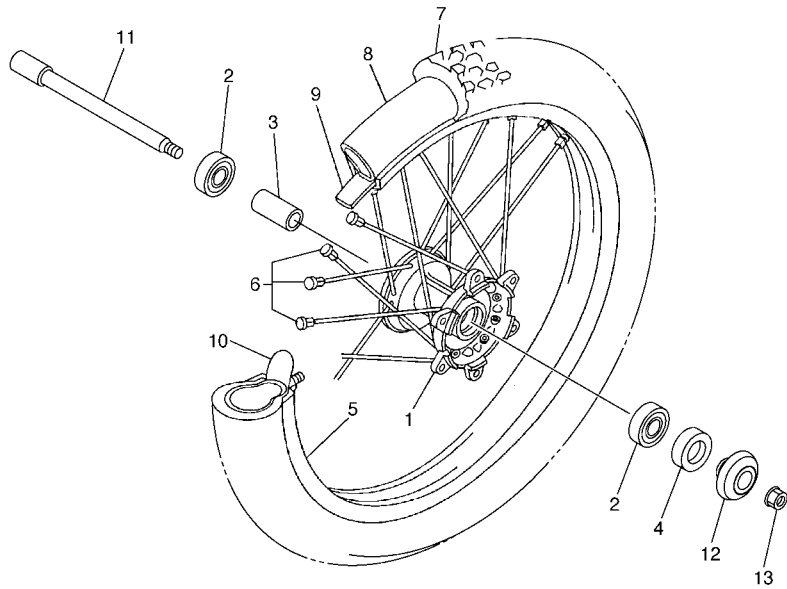

FIG. 30 FRONT WHEEL

REF. NO.	PART NO.	DESCRIPTION	1HB2	1HB3	1HB4	REMARKS
1	5NG-25111-50	HUB, FRONT	1	1	1	
2	93306-90409	BEARING	2	2	2	
3	5NY-25117-00	SPACER, BEARING	1	1	1	
4	93102-26468	OIL SEAL	1	1	1	
5	94416-21018	RIM (1.60-21)	1	1	1	
6	5NY-25104-00	SPOKE SET, FRONT	1	1	1	
7	94108-21015	TIRE (80/100-21 51M D739FA)	1	1		DUNLOP(ZAF)
	*	TIRE (90/90-21 M/C 54M M+S)		1	1	LM METZELER(OCE)
8	94227-21101	TUBE (80/100-21 M/C TR4)	1	1		DUNLOP(ZAF)
	*	TUBE (80/100-21)		1	1	LM PIRELLI(OCE)
9	94309-21161	BAND, RIM (22-21)	1	1		DUNLOP(ZAF)
	*	BAND, RIM (80/100-21)		1	1	LM PIRELLI(OCE)
10	5SF-25394-00	SPACER, BEAD	1	1	1	
11	1C3-25181-10	AXLE, WHEEL	1	1	1	
12	5TJ-2510C-80	COLLAR ASSY.	1	1	1	
13	90179-16011	NUT	1	1	1	



5TJB100-E300

FIG. 31 FRONT BRAKE CALIPER

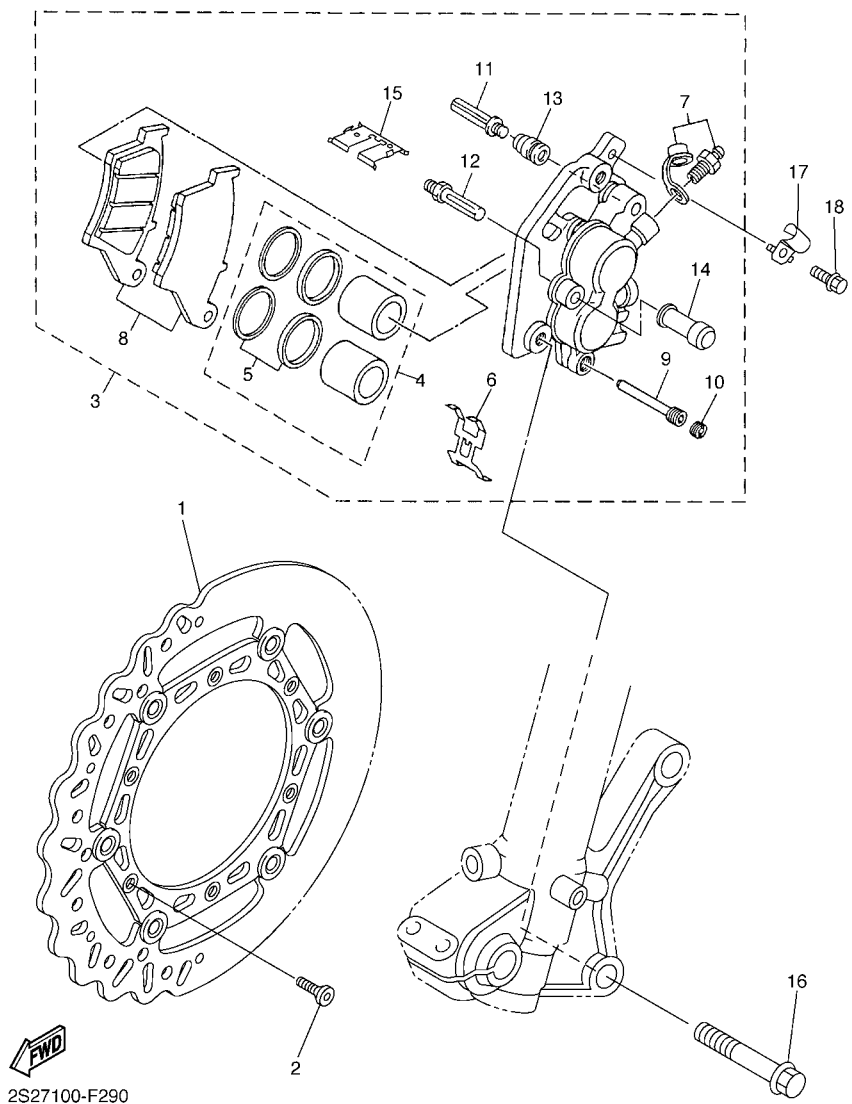

REF. NO.	PART NO.	DESCRIPTION	1HB2	1HB3	1HB4	REMARKS
1	2S2-2581T-70	DISK BRAKE ASSY	1	1	1	
2	90151-06051	SCREW, COUNTERSUNK	6	6	6	
3	1C3-2580T-00	CALIPER ASSY (LEFT)	1	1	1	
4	5UN-W0057-00	.PISTON ASSY, CALIPER	1	1	1	
5	3JD-W0047-00	..CALIPER SEAL KIT	1	1	1	
6	5DH-25919-00	.SUPPORT, PAD	1	1	1	
7	1UY-W0048-50	.BLEED SCREW KIT	1	1	1	
8	5MV-W0045-01	.BRAKE PAD KIT	1	1	1	
9	5DH-25933-00	.PIN, PAD	1	1	1	
10	5DH-25916-00	.PLUG	1	1	1	
11	3SP-25926-51	.BOLT	1	1	1	
12	3SP-25914-51	.PIN, SLIDE	1	1	1	
13	3JD-25917-00	.BOOT, CALIPER	1	1	1	
14	1UY-25937-51	.BOOT 2	1	1	1	
15	5DH-25849-00	.RETAINER, CALIPER	1	1	1	
16	90105-08137	BOLT, FLANGE	2	2	2	
17	1C3-25875-50	HOLDER, BRAKE HOSE 1	1	1	1	
18	90105-06105	BOLT, FLANGE	1	1	1	

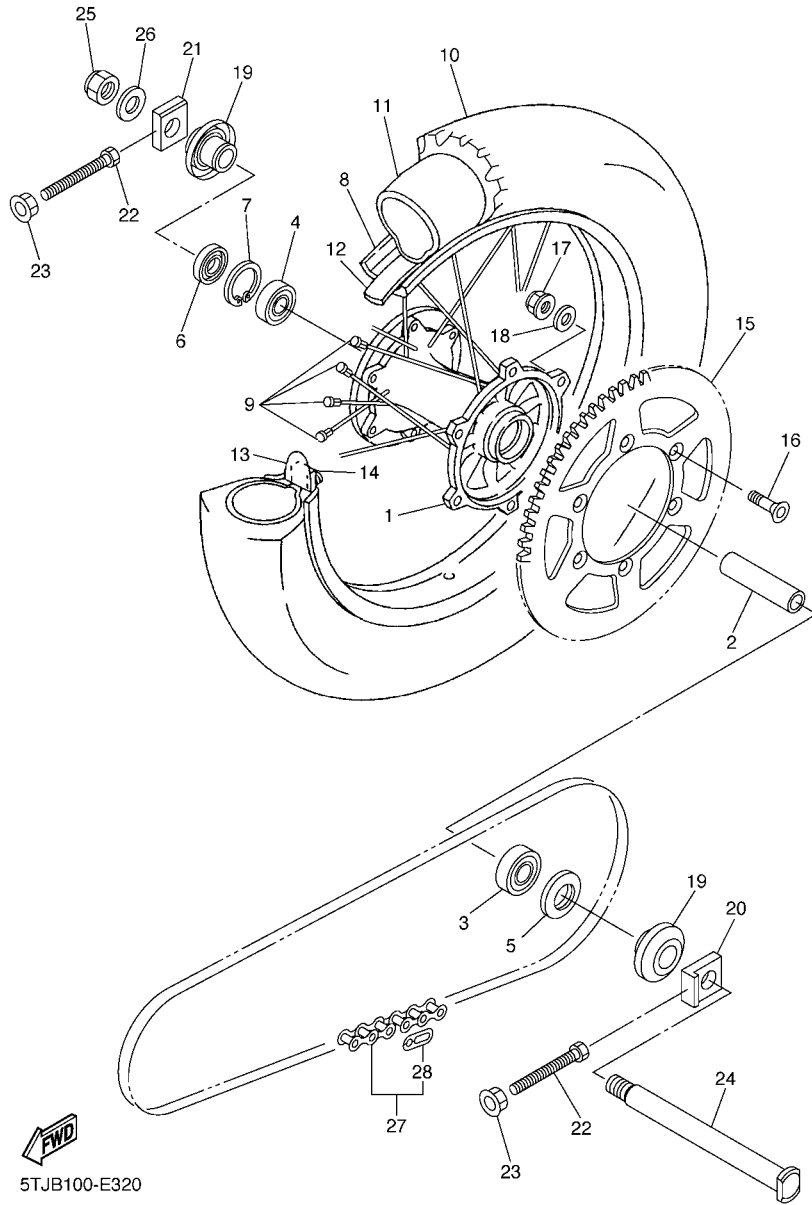

5TJB100-E320

FIG. 32 REAR WHEEL

REF. NO.	PART NO.	DESCRIPTION	1HB2	1HB3	1HB4	REMARKS
1	5ET-25311-00	HUB, REAR	1	1	1	
2	5ET-25317-00	SPACER, BEARING	1	1	1	
3	93306-27212	BEARING	1	1	1	
4	93306-07202	BEARING	1	1	1	
5	93106-30001	OIL SEAL	1	1	1	
6	93106-30045	OIL SEAL	1	1	1	
7	99009-45500	CIRCLIP	1	1	1	
8	94421-18008	RIM (2.15-18)	1	1	1	
9	5GS-25304-00	SPOKE SET, REAR	1	1	1	
10	94111-18012	TIRE (110/100-18 64M D756)	1	1		DUNLOP(ZAF)
*		TIRE (130/90-18 M/C 69M M+S)		1	1	LM METZELER(OCE)
11	94212-18188	TUBE (110-140/80-100-18 M/C)	1	1		DUNLOP(ZAF)
*		TUBE (120-150/70-90-18 M/C)		1	1	LM METZELER(OCE)
12	94309-18146	BAND, RIM (25-18)	1	1		DUNLOP(ZAF)
*		BAND, RIM (3.50-18)		1	1	LM METZELER(OCE)
13	3JE-25394-00	SPACER, BEAD	2	2	2	
14	4XM-25364-00	DAMPER	2	2	2	
15	5TJ-25450-80	SPROCKET, DRIVEN (50T)	1	1		STD FOR CAN,ZAF
	1C3-25447-00	SPROCKET, DRIVEN (47T)		1		STD
	1C3-25450-00	SPROCKET, DRIVEN (50T)		1		STD FOR OCE
	5GS-25448-50	SPROCKET, DRIVEN (48T)	1	1	1	AP EXCEPT FOR OCE
	5TJ-25452-80	SPROCKET, DRIVEN (52T)	1	1	1	AP EXCEPT FOR OCE
	5TJ-25450-80	SPROCKET, DRIVEN (50T)		1		AP
	1C3-25448-00	SPROCKET, DRIVEN (48T)		1		AP FOR OCE
	1C3-25449-00	SPROCKET, DRIVEN (49T)		1		AP FOR OCE
	1C3-25451-00	SPROCKET, DRIVEN (51T)		1		AP FOR OCE
	1C3-25452-00	SPROCKET, DRIVEN (52T)		1		AP FOR OCE

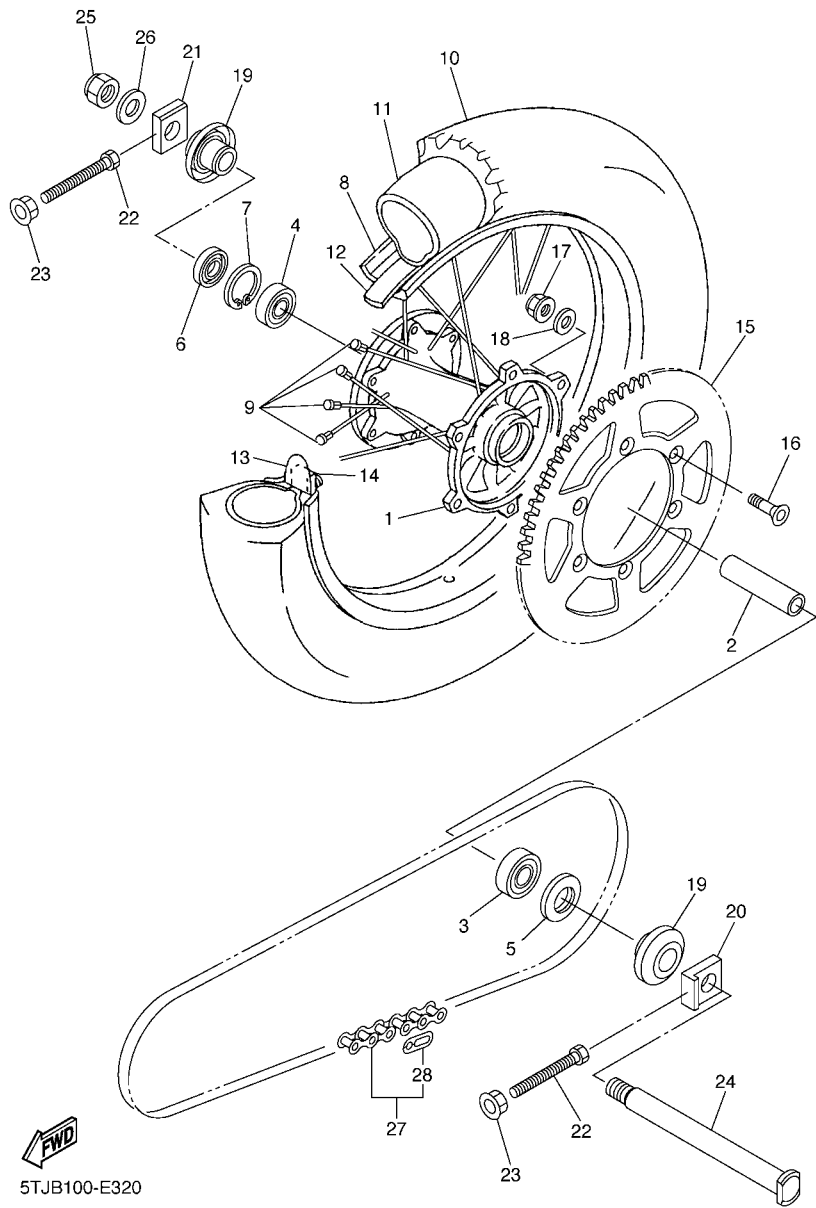

FIG. 32 REAR WHEEL

REF. NO.	PART NO.	DESCRIPTION	1HB2	1HB3	1HB4	REMARKS
16	90109-08078	BOLT	6	6	6	
17	90185-08008	NUT, SELF-LOCKING	6	6	6	
18	90201-08048	WASHER, PLATE	6	6	6	
19	5TJ-2530S-80	COLLAR ASSY	2	2	2	
20	1C3-25388-H0	PULLER, CHAIN 1	1	1	1	
21	1C3-25389-H0	PULLER, CHAIN 2	1	1	1	
22	90101-08006	BOLT	2	2	2	
23	90179-08019	NUT	2	2	2	
24	1C3-25381-90	AXLE, WHEEL	1	1	1	
25	90185-20002	NUT, SELF-LOCKING	1	1	1	
26	90201-20020	WASHER, PLATE	1	1	1	
27	9Y58A-76113	CHAIN (DID 520VM-114LL)	1	1	1	
28	94681-76021	.JOINT, CHAIN (DID 520VM-ZJ)	1	1	1	

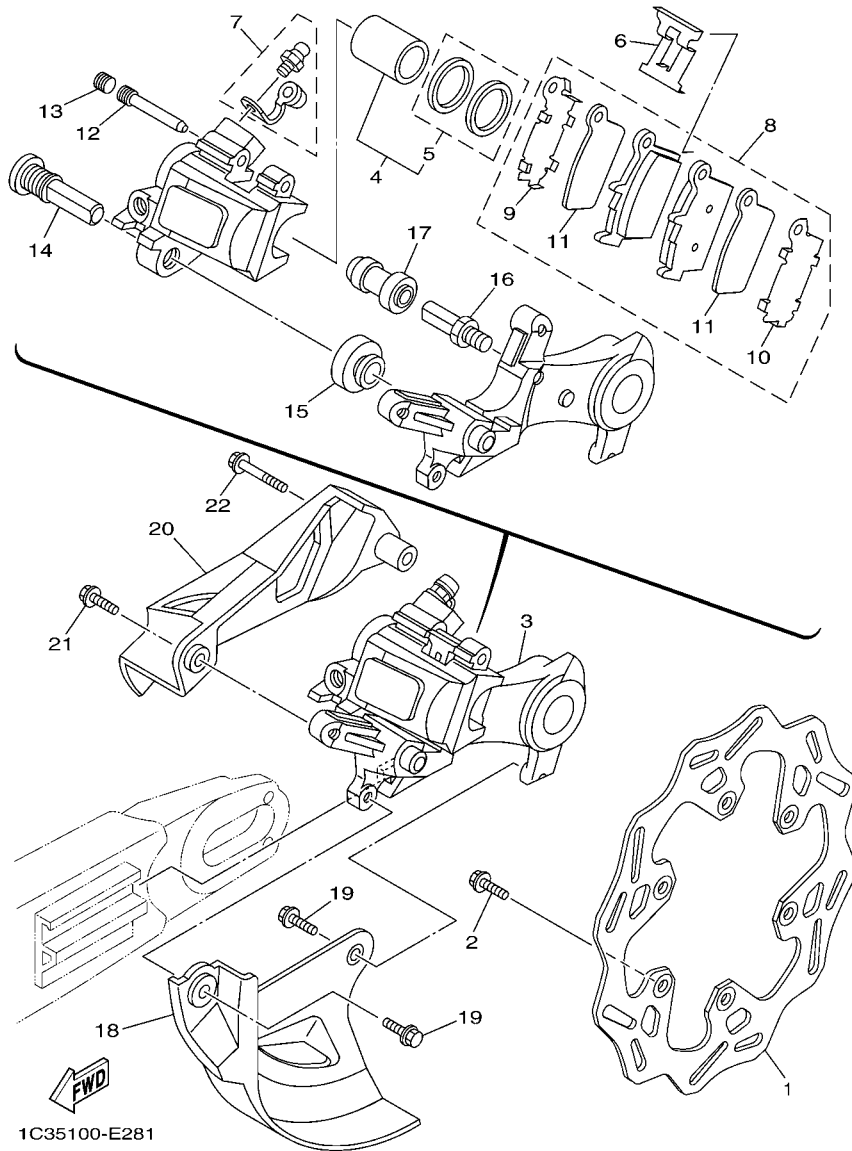
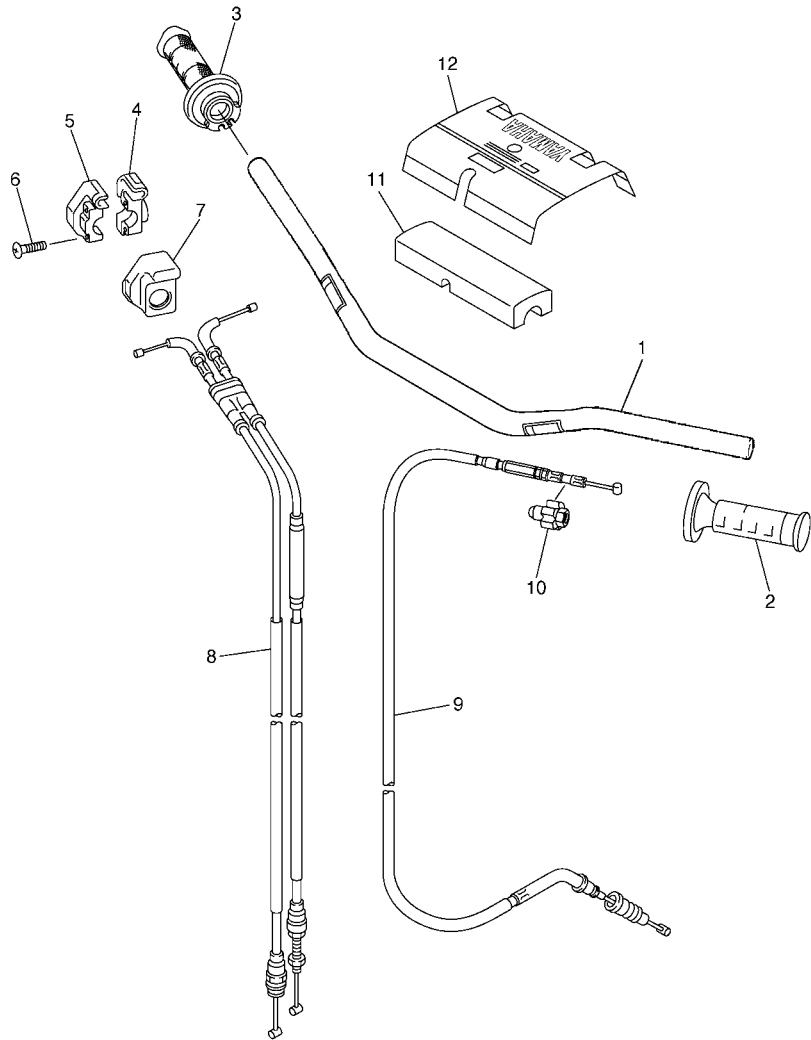

FIG. 33 REAR BRAKE CALIPER

REF. NO.	PART NO.	DESCRIPTION	1HB2	1HB3	1HB4	REMARKS
1	2S2-2582W-70	DISK, REAR BRAKE 2	1	1	1	
2	90105-06108	BOLT, FLANGE	6	6	6	
3	1C3-2580W-72	CALIPER ASSY, REAR 2	1	1	1	
4	5UN-W0057-50	.PISTON ASSY, CALIPER	1	1	1	
5	5UN-W0047-50	..CALIPER SEAL KIT	1	1	1	
6	5DH-25919-50	..SUPPORT, PAD	1	1	1	
7	1UY-W0048-50	.BLEED SCREW KIT	1	1	1	
8	1C3-W0046-B0	.BRAKE PAD KIT 2	1	1	1	
9	5UN-25828-60	..SHIM, CALIPER	1	1	1	
10	5UN-25827-60	..SHIM, CALIPER	1	1	1	
11	5UN-22898-60	..INSULATOR, HEAT	2	2	2	
12	8CR-25924-00	.PIN, PAD	1	1	1	
13	5DH-25916-00	.PLUG	1	1	1	
14	5DH-25914-50	.PIN, SLIDE	1	1	1	
15	3JD-25917-00	.BOOT, CALIPER	1	1	1	
16	5UN-25914-00	.PIN, SLIDE	1	1	1	
17	1UY-25937-51	.BOOT 2	1	1	1	
18	1C3-25718-50	PROTECTOR, DISK BRAKE	1	1	1	
19	90105-06110	BOLT, FLANGE	2	2	2	
20	1C3-27491-50	PROTECTOR	1	1	1	
21	90105-06107	BOLT, FLANGE	1	1	1	
22	90105-06111	BOLT, FLANGE	1	1	1	



5TJE100-F340

FIG. 34 STEERING HANDLE & CABLE

REF. NO.	PART NO.	DESCRIPTION	1HB2	1HB3	1HB4	REMARKS
1	5XC-26111-L1	HANDLEBAR	1	1	1	
2	4GY-26241-00	GRIP	1	1	1	
3	5TJ-26240-C0	GRIP ASSY	1	1	1	
4	5BE-26281-00	CAP, GRIP UPPER	1	1	1	
5	5BE-26282-00	CAP, GRIP UNDER	1	1	1	
6	98507-05020	SCREW, PAN HEAD	2	2	2	
7	5SF-26287-10	COVER, CAP GRIP	1	1	1	
8	5UM-26302-E0	THROTTLE CABLE ASSY	1	1	1	
9	5TJ-26335-E0	CABLE, CLUTCH	1	1	1	
10	1C3-26342-50	BOOT, CABLE	1	1	1	
11	5XC-26124-90	PROTECTOR, HANDLEBAR	1	1	1	
12	5XC-26143-L0	COVER,HAND,UPPER 1	1	1	1	

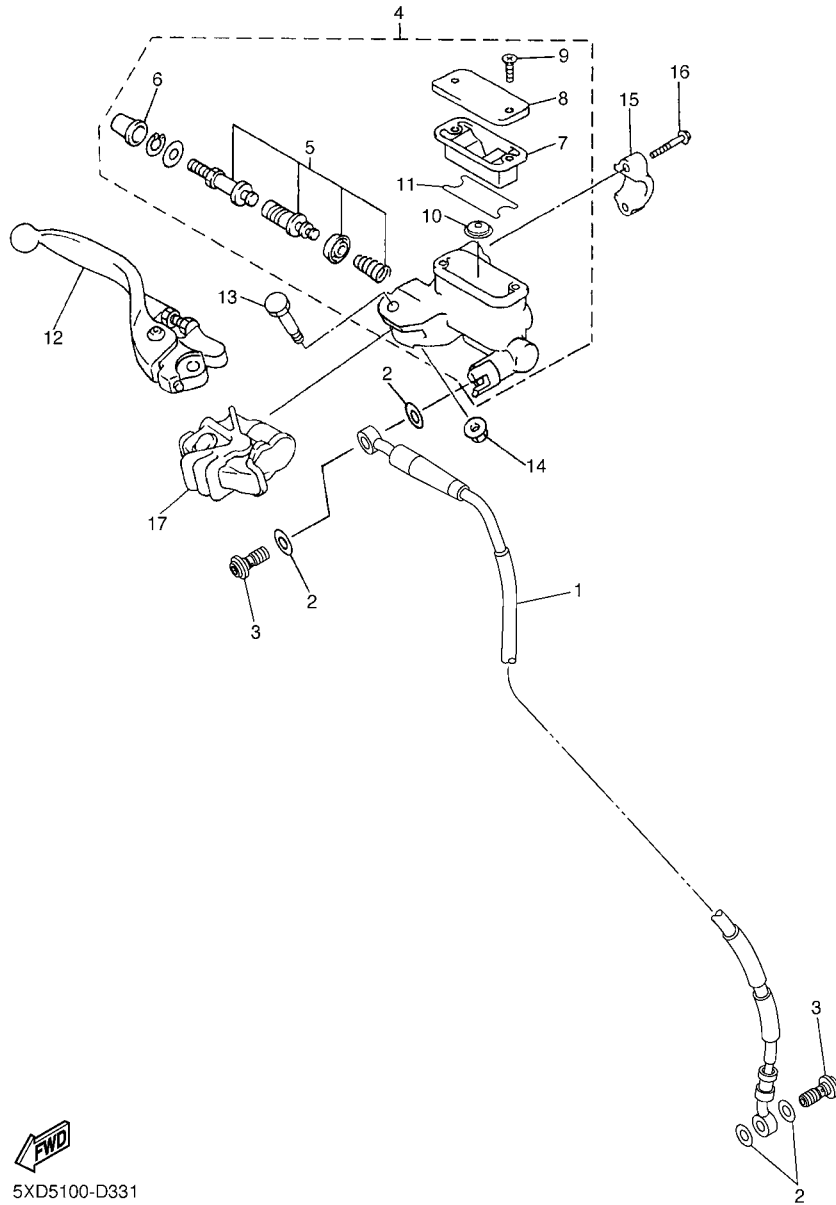

5XD5100-D331

FIG. 35 FRONT MASTER CYLINDER

REF. NO.	PART NO.	DESCRIPTION	1HB2	1HB3	1HB4	REMARKS
1	5TJ-25872-80	HOSE, BRAKE 1	1	1	1	
2	90430-10005	GASKET	4	4	4	
3	90401-10172	BOLT, UNION	2	2	2	
4	5XE-W2587-10	MASTER CYLINDER SUB ASSY	1	1	1	
5	5NY-W0041-00	.CYLINDER KIT, MASTER	1	1	1	
6	5NY-25868-00	.BOOT, MASTER CYLINDER	1	1	1	
7	5XE-25854-00	.DIAPHRAGM, RESERVOIR	1	1	1	
8	5MV-25852-01	.CAP, RESERVOIR	1	1	1	
9	98706-04012	.SCREW, FLAT HEAD	2	2	2	
10	5CG-25715-00	.SEPARATOR ASSY	1	1	1	
11	5XE-25853-00	.FLOAT, RESERVOIR	1	1	1	
12	1C3-83922-50	LEVER 2	1	1	1	
13	5MV-2589F-00	BOLT, LEVER	1	1	1	
14	95701-06500	NUT, WITH WASHER	1	1	1	
15	5MV-25867-00	BRACKET, MASTER CYLINDER	1	1	1	
16	5MV-25833-00	BOLT, FITTING	2	2	2	
17	5NY-26372-00	COVER, HANDLE LEVER 1	1	1	1	

FIG. 36 STAND & FOOTREST

REF. NO.	PART NO.	DESCRIPTION	1HB2	1HB3	1HB4	REMARKS
1	2S2-27200-11	PEDAL, BRAKE	1	1	1	
2	1C3-27217-10	BOLT	1	1	1	
3	93210-11073	O-RING	2	2	2	
4	91402-20012	PIN, COTTER	1	1	1	
5	90506-16007	SPRING, TENSION	1	1	1	
6	90240-08120	PIN, CLEVIS	1	1	1	
7	90201-08044	WASHER, PLATE	1	1	1	
8	90468-16001	CLIP	1	1	1	
9	5XC-27411-M1	FOOTREST 1	1	1	1	
10	5XC-27421-M1	FOOTREST 2	1	1	1	
11	90240-10004	PIN, CLEVIS	2	2	2	
12	91402-25015	PIN, COTTER	2	2	2	
13	90508-28015	SPRING, TORSION	1	1	1	
14	90508-28018	SPRING, TORSION	1	1	1	
15	90201-10032	WASHER, PLATE	2	2	2	
16	5UM-27311-E0	STAND, SIDE	1	1	1	
17	90506-30005	SPRING, TENSION	1	1	1	
18	90445-217G3	HOSE (L70)	1	1	1	
19	90109-10026	BOLT	1	1	1	
20	90201-10045	WASHER, PLATE	1	1	1	
21	90387-1003G	COLLAR	1	1	1	
22	5UM-27315-E0	LINK, SIDE STAND	1	1	1	
23	90185-10018	NUT, SELF-LOCKING	1	1	1	

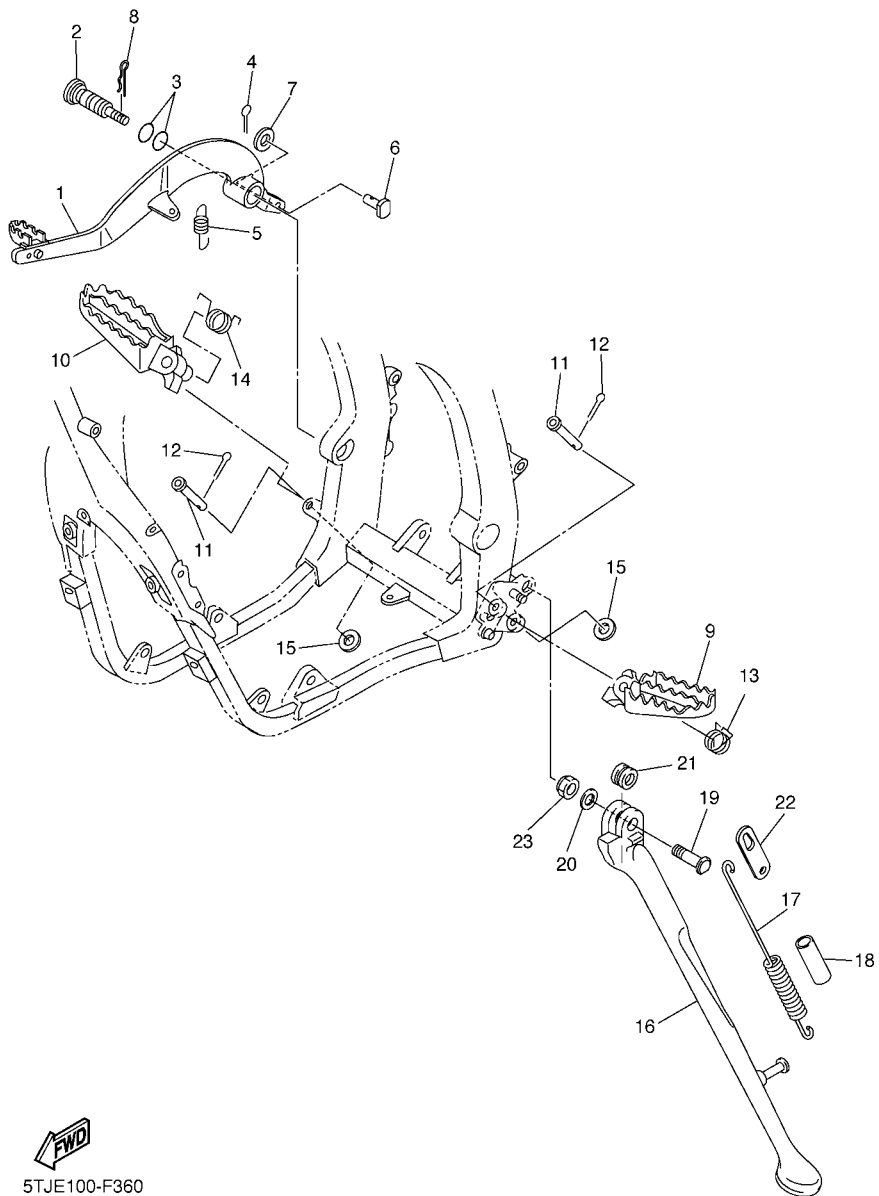

FWD
5TJP100-H370

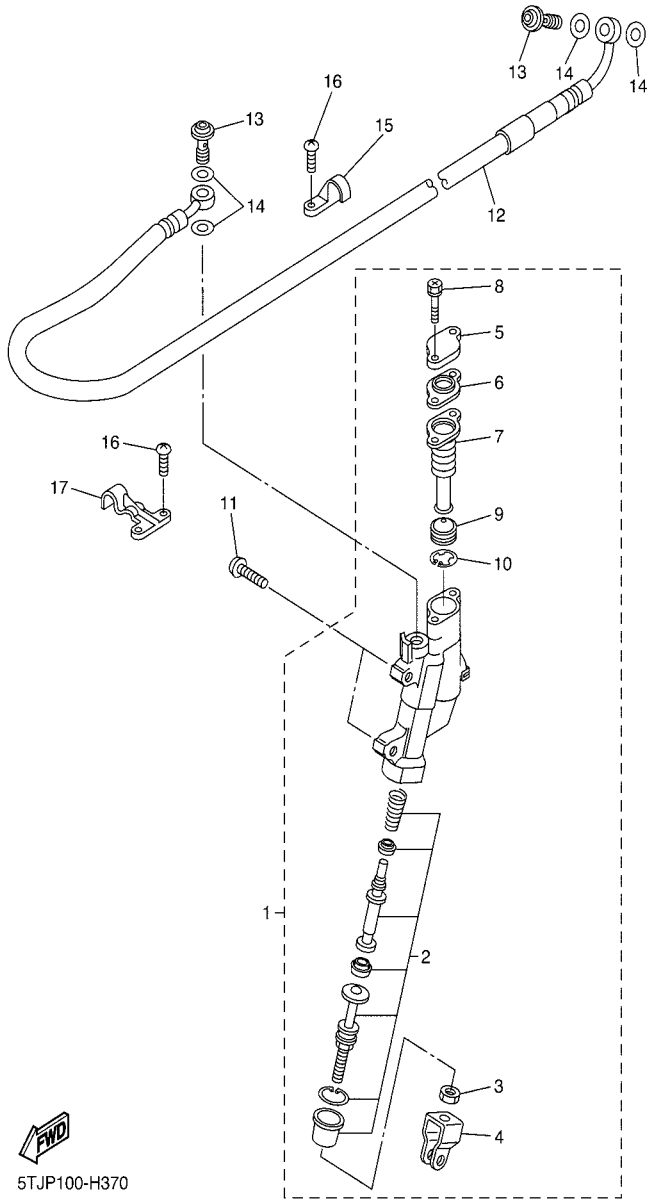
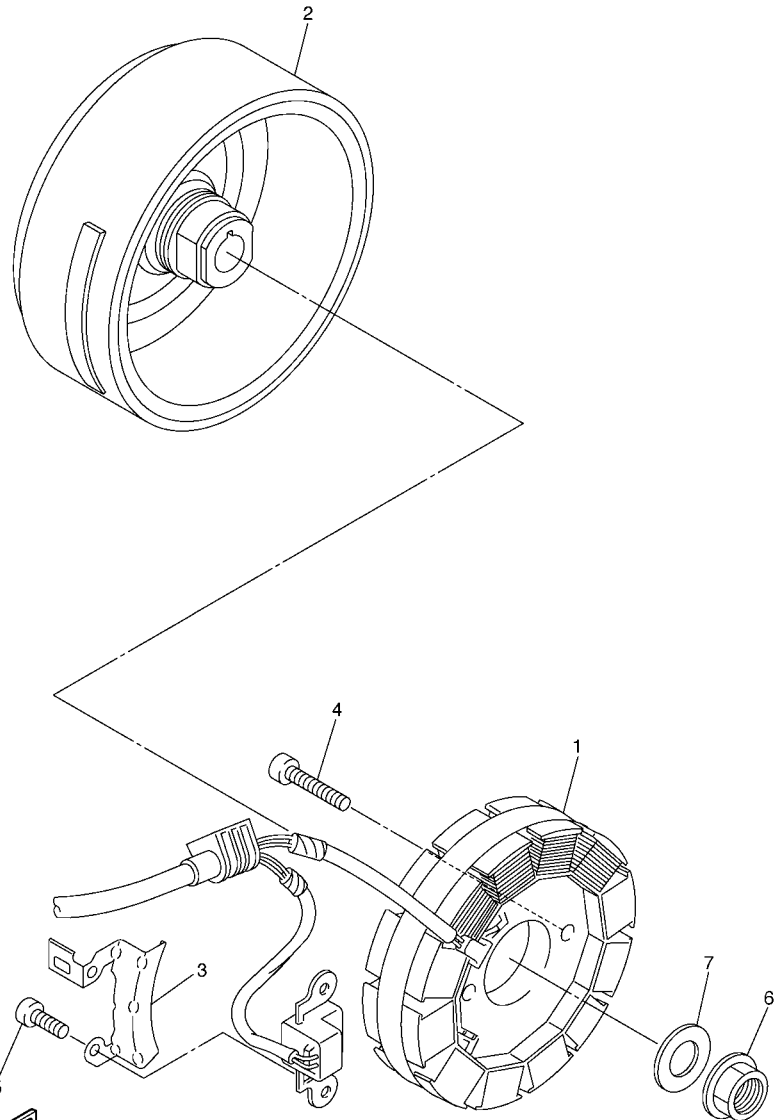

FIG. 37 REAR MASTER CYLINDER

REF. NO.	PART NO.	DESCRIPTION	1HB2	1HB3	1HB4	REMARKS
1	17D-2583V-00	RR. MASTER CYLINDER ASSY.	1	1	1	
2	5UN-W0042-50	.CYLINDER KIT, MASTER	1	1	1	
3	5UN-27218-00	.NUT	1	1	1	
4	5UN-27222-00	.JOINT	1	1	1	
5	5UN-25852-50	.CAP, RESERVOIR	1	1	1	
6	5UN-2585B-00	.PLATE, DIAPHRAGM	1	1	1	
7	5UN-25854-00	.DIAPHRAGM, RESERVOIR	1	1	1	
8	5UN-27217-00	.BOLT	2	2	2	
9	5CG-25715-00	.SEPARATOR ASSY	1	1	1	
10	5CG-2585G-00	.CIRCLIP	1	1	1	
11	90111-06116	BOLT,HEX. SOCKET BUTTON	2	2	2	
12	5XC-25873-L0	HOSE, BRAKE 2	1	1	1	
13	90401-10172	BOLT, UNION	2	2	2	
14	90430-10005	GASKET	4	4	4	
15	1C3-25886-50	HOLDER, BRAKE HOSE	1	1	1	
16	98502-05010	SCREW, PAN HEAD	4	4	4	
17	1C3-25876-50	HOLDER, BRAKE HOSE 2	1	1	1	



5TJE100-F380

FIG. 38 GENERATOR

REF. NO.	PART NO.	DESCRIPTION	1HB2	1HB3	1HB4	REMARKS
1	5TJ-81410-50	STATOR ASSY	1	1	1	
2	5TJ-81450-30	ROTOR ASSY	1	1	1	
3	5TJ-81528-00	CLAMP 1	1	1	1	
4	90149-05024	SCREW	2	2	2	
5	90110-06248	BOLT, HEXAGON SOCKET HEAD	2	2	2	
6	90179-12657	NUT	1	1	1	
7	90201-12020	WASHER, PLATE	1	1	1	

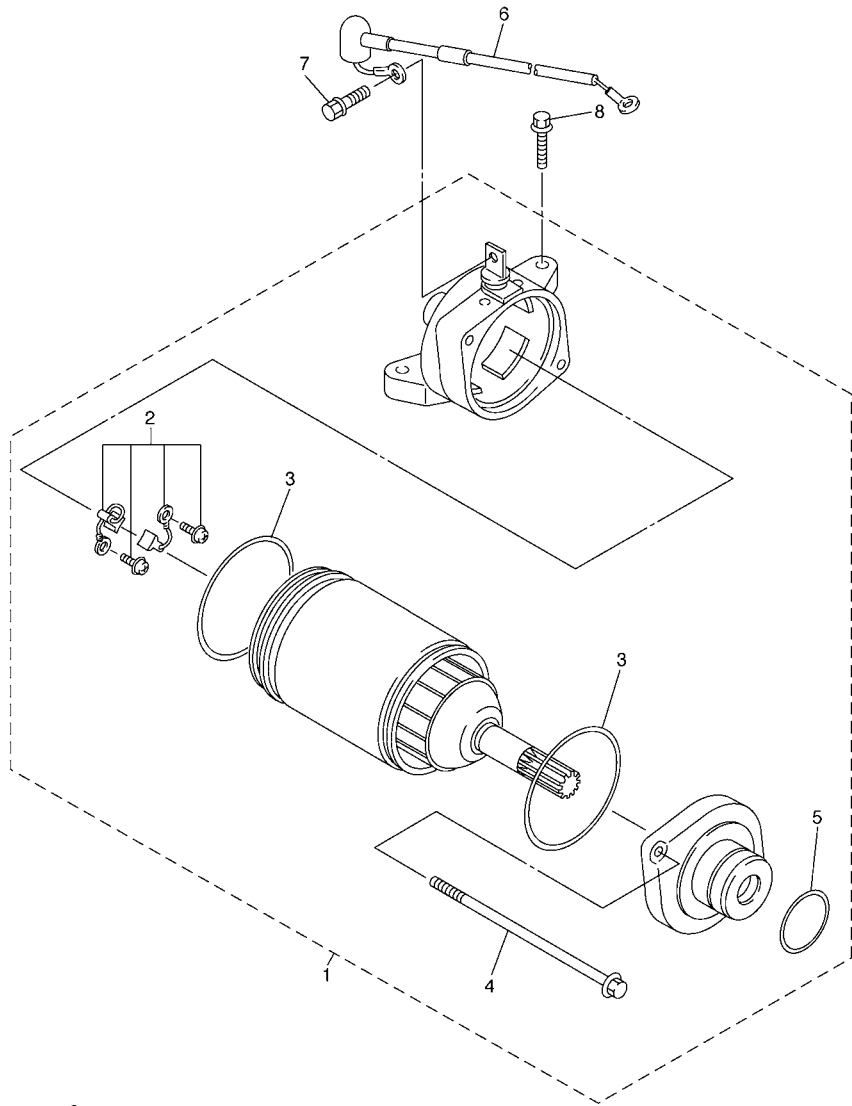

5TJE100-F390

FIG. 39 STARTING MOTOR

REF. NO.	PART NO.	DESCRIPTION	1HB2	1HB3	1HB4	REMARKS
1	5TJ-81890-30	MOTOR ASSY	1	1	1	
2	5TJ-81801-00	.BRUSH SET	1	1	1	
3	93210-44678	.O-RING	2	2	2	
4	50W-81846-M1	.SCREW	2	2	2	
5	93210-25711	.O-RING	1	1	1	
6	5TJ-8183G-30	CORD COMP.	1	1	1	
7	5TJ-81828-01	BOLT 2	1	1	1	
8	95022-06025	BOLT, FLANGE	2	2	2	

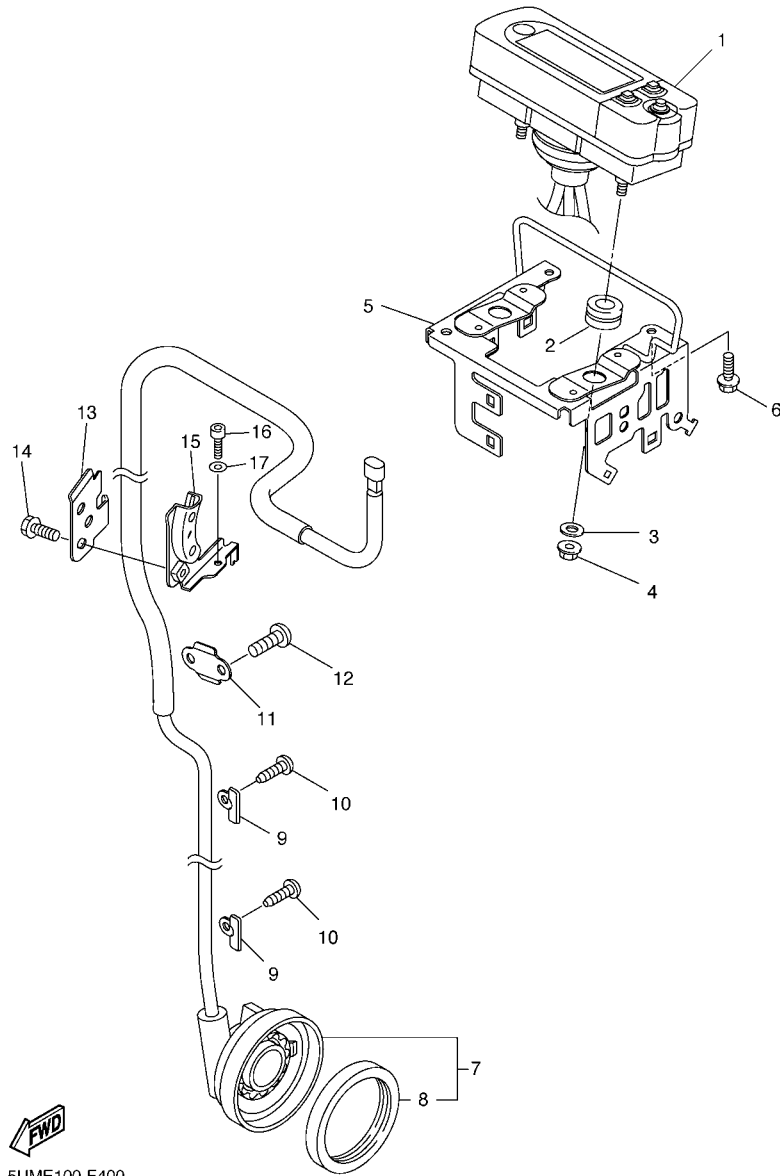

5UME100-F400

FIG. 40 METER

REF. NO.	PART NO.	DESCRIPTION	1HB2	1HB3	1HB4	REMARKS
1	5TJ-83500-F0	SPEEDOMETER ASSY (KM/H)	1	1	1	
	5TJ-83500-G0	SPEEDOMETER ASSY (MPH)		1		FOR GBR
2	90480-14012	GROMMET	2	2	2	
3	90201-05021	WASHER, PLATE	2	2	2	
4	95702-05500	NUT, FLANGE	2	2	2	
5	5UM-83519-E0	BRACKET, METER	1	1	1	
6	90105-06110	BOLT, FLANGE	2	2	2	
7	5TJ-83755-C0	SENSOR, SPEED	1	1	1	
8	93105-47007	.OIL SEAL	1	1	1	
9	5TJ-8375F-C0	PLATE 2	2	2	2	
10	97702-40010	SCREW, TAPPING	2	2	2	
11	5TJ-8375E-C0	PLATE 1	1	1	1	
12	92012-05008	BOLT, BUTTON HEAD	2	2	2	
13	5UM-83595-E0	CLAMP	1	1	1	
14	90105-06105	BOLT, FLANGE	1	1	1	
15	5UM-23591-E0	BRACKET 1	1	1	1	
16	92012-06012	BOLT, BUTTON HEAD	1	1	1	
17	92902-06600	WASHER, PLATE	1	1	1	

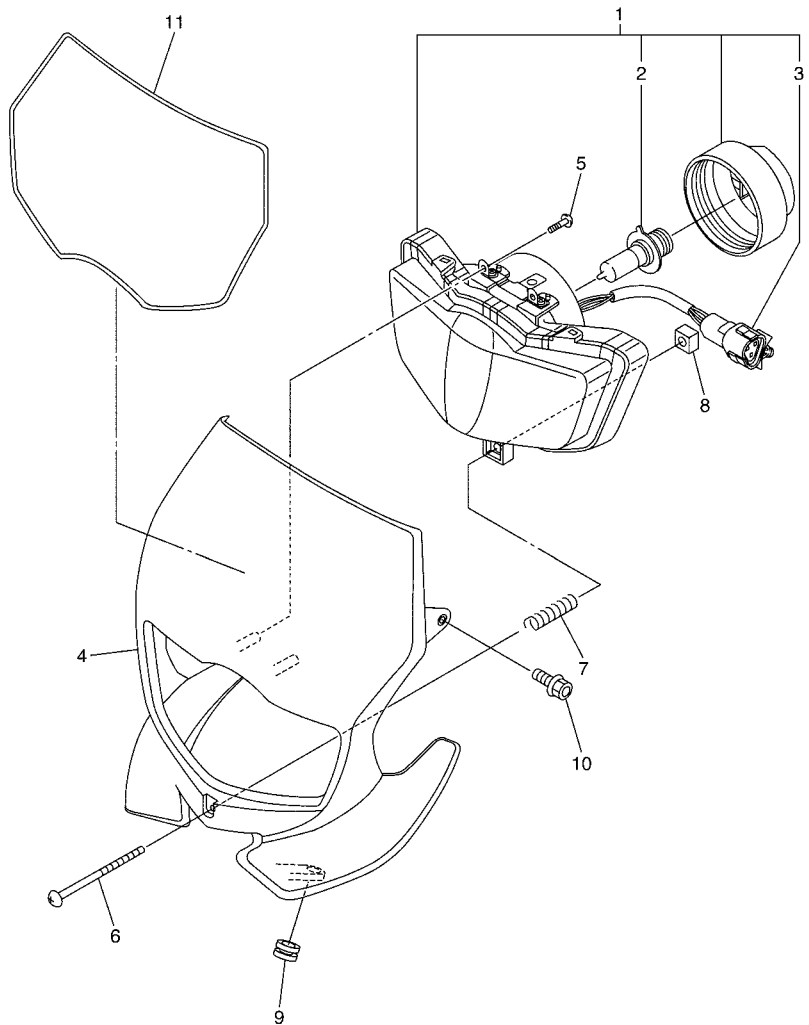

FWD
5TJJ100-G410

FIG. 41 HEADLIGHT

REF. NO.	PART NO.	DESCRIPTION	1HB2	1HB3	1HB4	REMARKS
1	5UM-84310-E1	HEADLIGHT UNIT ASSY	1	1	1	
2	5VM-84314-00	.BULB, HEADLIGHT(12V-35/36.5W)	1	1	1	HALOGEN
3	5UM-84340-E1	.SOCKET CORD ASSY 1	1	1	1	
4	5UM-84330-E0	BODY ASSY	1	1	1	
5	97702-50516	SCREW, TAPPING	2	2	2	
6	90157-04005	SCREW, PAN HEAD	1	1	1	
7	90501-120A3	SPRING, COMPRESSION	1	1	1	
8	5BF-84334-00	NUT, ADJUSTING	1	1	1	
9	90480-12020	GROMMET	2	2	2	
10	90105-06064	BOLT, FLANGE	2	2	2	
11	5TJ-2339E-00	GRAPHIC 1	1	1	1	

FIG. 42 TAILLIGHT

REF. NO.	PART NO.	DESCRIPTION	1HB2	1HB3	1HB4	REMARKS
1	5UM-84710-E0	TAILLIGHT UNIT ASSY	1	1	1	
2	5UM-84736-E0	DAMPER, TAIL 1	1	1	1	
3	5UM-84737-E0	DAMPER, TAIL 2	1	1	1	
4	5TJ-84716-U0	COVER, TAILLIGHT	1			
	5UM-84716-E0	COVER, TAILLIGHT		1	1	
5	5TJ-84781-U0	BRACKET 1	1			
6	90201-047R8	WASHER, PLATE	3			
7	90267-48084	RIVET, BLIND	3			
8	3Y6-85130-02	REAR REFLECTOR ASSY	1			
9	95602-05200	NUT, SELF-LOCKING	1			
10	90160-05012	SCREW, ROUND TAPPING	3			
	97702-50016	SCREW, TAPPING		3	3	
11	90464-11M18	CLAMP	3	3	3	
12	97702-40010	SCREW, TAPPING	3	3	3	

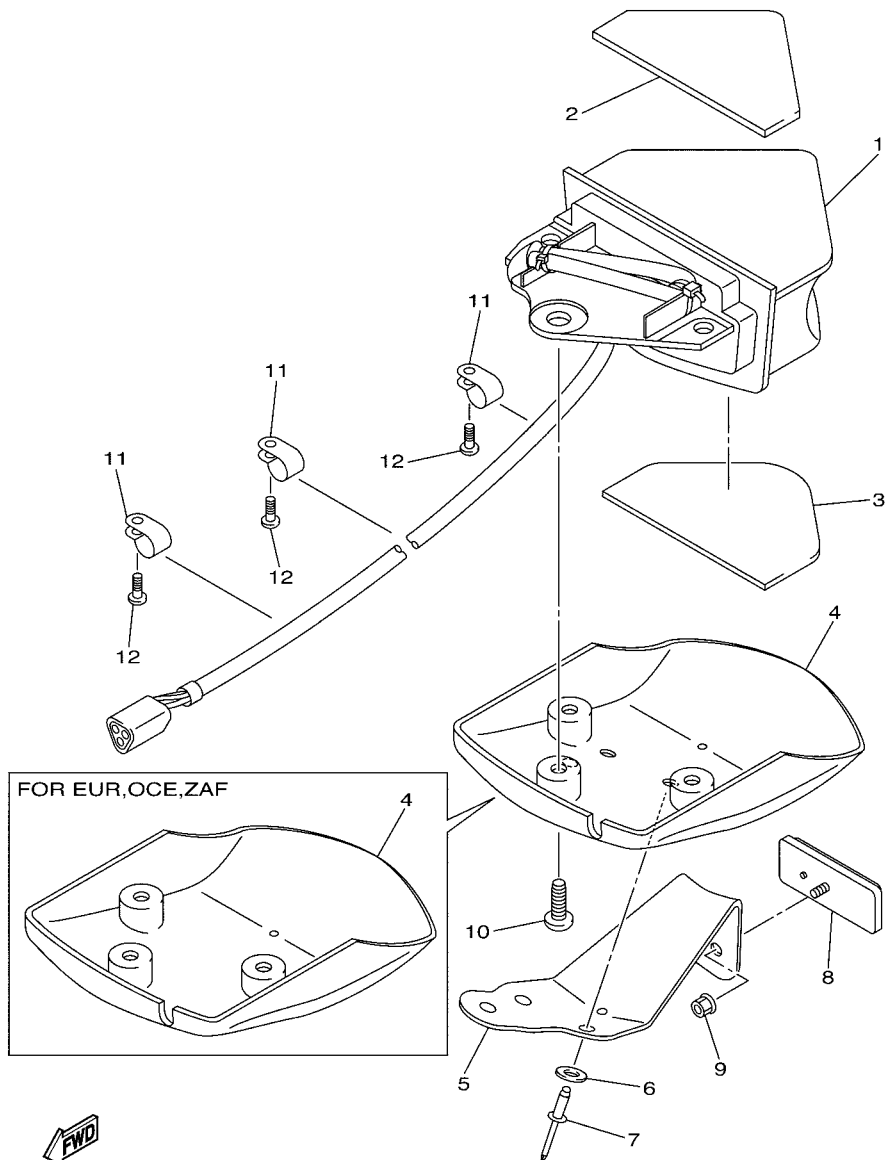

5TJU100-J420

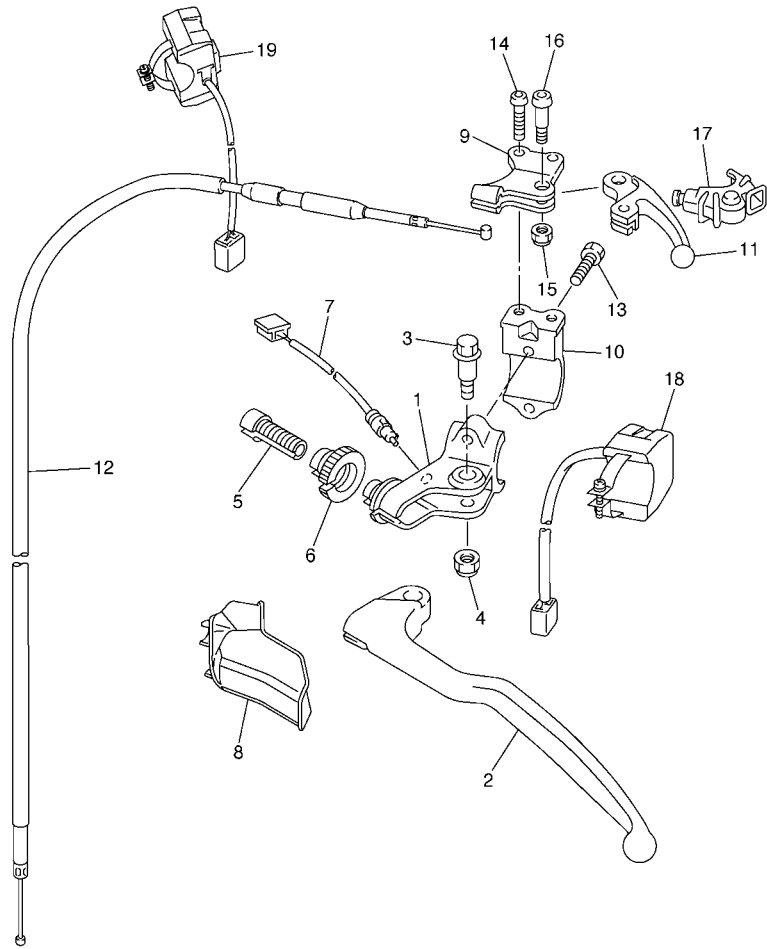
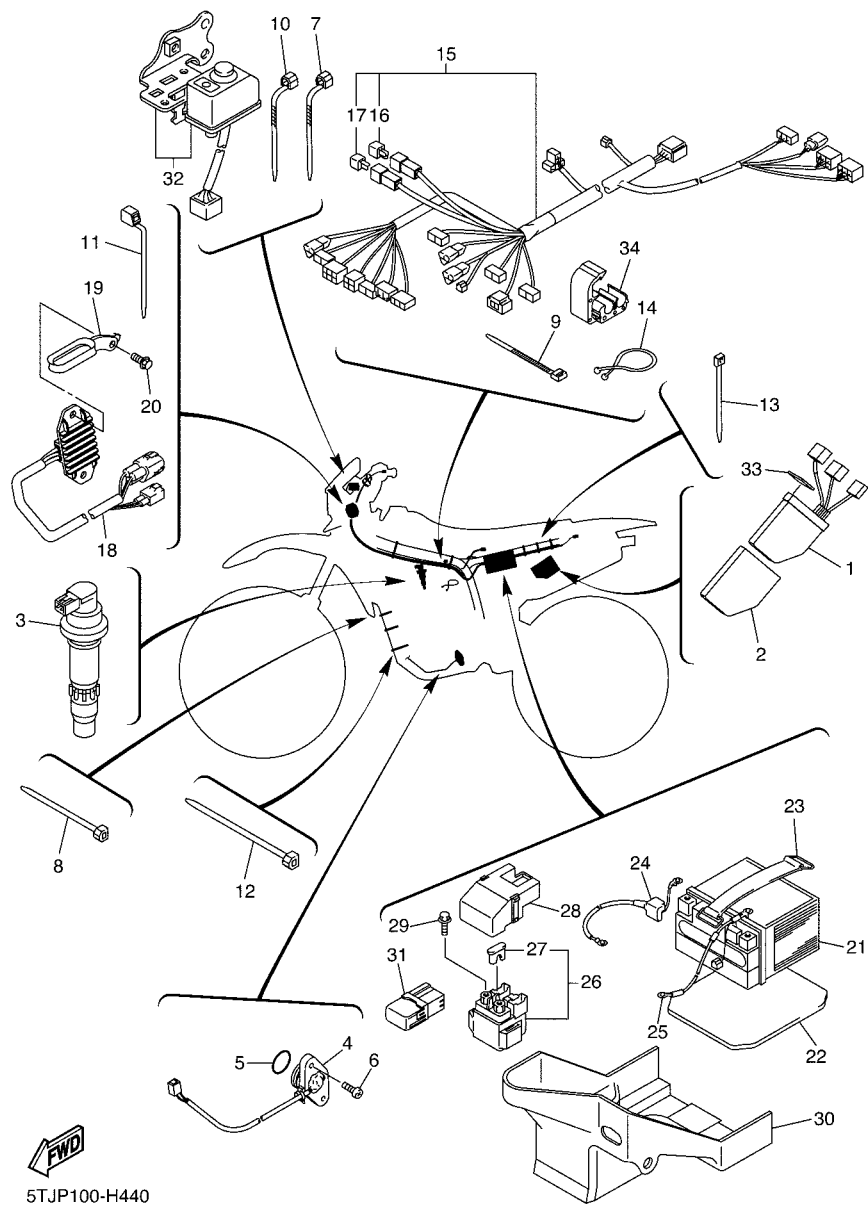

FIG. 43 HANDLE SWITCH & LEVER

REF. NO.	PART NO.	DESCRIPTION	1HB2	1HB3	1HB4	REMARKS
1	5TJ-82911-80	HOLDER, LEVER 1	1	1	1	
2	5TJ-83912-80	LEVER 1	1	1	1	
3	90109-06034	BOLT	1	1	1	
4	5LP-84126-10	NUT, LENS FITTING	1	1	1	
5	5HD-26337-00	BOLT, ADJUSTING	1	1	1	
6	5HD-83951-00	BOLT, CABLE ADJUSTING	1	1	1	
7	5TJ-82917-02	SWITCH	1	1	1	
8	5TJ-26372-80	COVER, HANDLE LEVER 1	1	1	1	
9	5XD-82946-00	HOLDER, STARTER LEVER	1	1	1	
10	5XD-82913-00	HOLDER, LEVER LOWER 1	1	1	1	
11	5TA-83941-00	LEVER, STARTER	1	1	1	
12	5UM-26334-E0	CABLE, STARTER 2	1	1	1	
13	97002-05016	BOLT	2	2	2	
14	92012-05012	BOLT, BUTTON HEAD	2	2	2	
15	95602-05100	NUT, U	1	1	1	
16	90149-05162	SCREW	1	1	1	
17	5TA-26339-00	BOOT	1	1	1	
18	5UM-83976-E2	SWITCH, ENGINE STOP	1	1	1	
19	5UM-83976-F2	SWITCH, HANDLE 1	1	1	1	



5TJP100-H440

FIG. 44 ELECTRICAL 1

REF. NO.	PART NO.	DESCRIPTION	1HB2	1HB3	1HB4	REMARKS
1	5TJ-85540-E0	C.D.I. UNIT ASSY	1			
	5TJ-85540-L0	C.D.I. UNIT ASSY		1		
	5TJ-85540-F0	C.D.I. UNIT ASSY			1	
2	5UM-85546-E0	BAND	1	1	1	
3	5TA-82310-10	IGNITION COIL ASSY	1	1	1	
4	5TJ-82540-01	NEUTRAL SWITCH ASSY	1	1	1	
5	93210-21001	O-RING	1	1	1	
6	90154-05022	SCREW, BINDING	2	2	2	
7	90464-13077	CLAMP	2	2	2	
8	90464-15152	CLAMP	3	3	3	
9	90465-13275	CLAMP	6	6	6	
10	90464-13073	CLAMP	3	3	3	
11	90464-16061	CLAMP	2	2	2	
12	90464-15195	CLAMP	1			
	90464-15195	CLAMP		3	3	
13	90465-13152	CLAMP	5	5	5	
14	90464-23041	CLAMP	1	1	1	
15	5TJ-82590-E0	WIRE HARNESS ASSY	1	1		
	5TJ-82590-F0	WIRE HARNESS ASSY			1	
16	5TJ-81980-00	.DIODE ASSY	1	1	1	
17	4WA-81980-00	.DIODE ASSY	1	1	1	
18	5UM-81960-E0	RECTIFIER & REGULATOR ASSY	1	1	1	
19	5UM-21288-E0	GUIDE, CABLE	1	1	1	
20	90105-06110	BOLT, FLANGE	2	2	2	
21	5TJ-82100-01	BATTERY ASSY (YTZ7S)	1	1	1	
22	5UM-82176-E0	DAMPER	1	1	1	
23	8CY-82131-00	BAND, BATTERY	1	1	1	

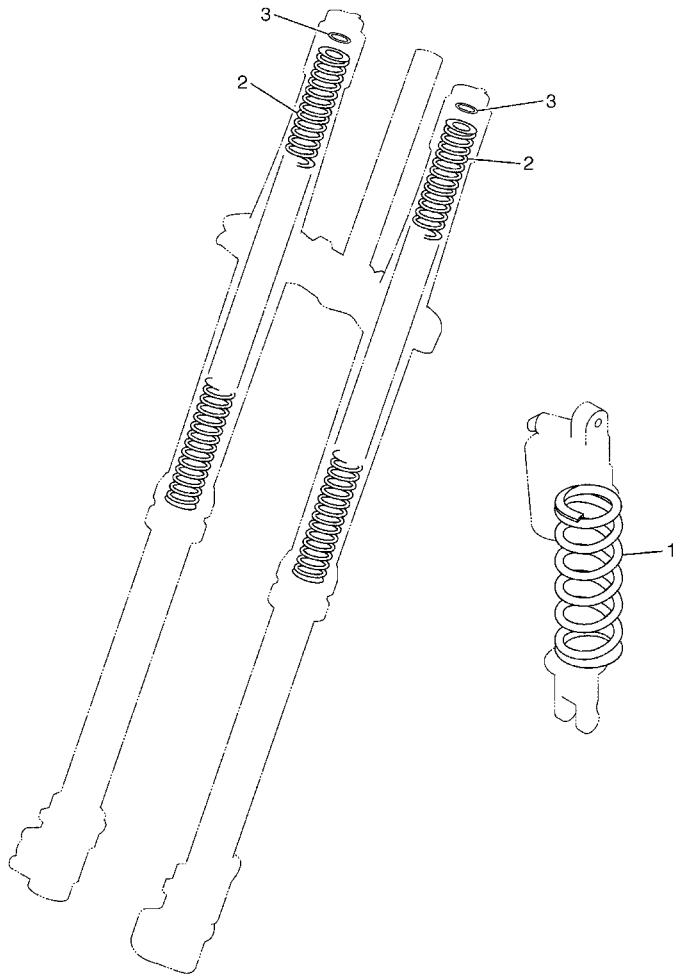

FIG. 45 ALTERNATE FOR CHASSIS

REF. NO.	PART NO.	DESCRIPTION	1HB2	1HB3	1HB4	REMARKS	
1	5UN-22212-00	SPRING (K=42N/MM)	1	1	1	AP	
	5UN-22212-10	SPRING (K=44N/MM)	1	1	1	AP	
	5UN-22212-20	SPRING (K=46N/MM)	1	1	1	AP	
	5UN-22212-30	SPRING (K=48N/MM)	1	1	1	AP	
	5UN-22212-40	SPRING (K=50N/MM)	1	1	1	AP	
	5UN-22212-50	SPRING (K=52N/MM)	1	1	1	AP	
	5UN-22212-60	SPRING (K=54N/MM)	1	1	1	AP	
	5UN-22212-70	SPRING (K=56N/MM)	1	1	1	AP	
	2	5TJ-23141-00	SPRING (K=4.0N/MM)	1	1	1	AP
		5TJ-23141-10	SPRING (K=4.1N/MM)	1	1	1	AP
5TJ-23141-20		SPRING (K=4.2N/MM)	1	1	1	AP	
5TJ-23141-30		SPRING (K=4.3N/MM)	1	1	1	AP	
5TJ-23141-40		SPRING (K=4.4N/MM)	1	1	1	AP	
5TJ-23141-50		SPRING (K=4.5N/MM)	1	1	1	AP	
5TJ-23141-60	SPRING (K=4.6N/MM)	1	1	1	AP		
3	5XE-23364-00	COLLAR 2	1	1	1	AP	



5XC1100-C390

NUMERICAL INDEX

PART NO.	REF. NO.	PART NO.	REF. NO.	PART NO.	REF. NO.	PART NO.	REF. NO.	PART NO.	REF. NO.	PART NO.	REF. NO.
5TJ-11101-10	1 - 1	3LD-12168-M1	3 - 13	2S2-13412-00	7 - 12	5UM-14451-E0	9 - 17	5TJ-14916-9M	10 - 12	4JT-1494F-09	10 - 22
5TJ-11126-00	9 - 43	3LD-12168-R1	3 - 13	5D3-13440-00	8 - 1	5TJ-14453-E0	9 - 13	5TJ-14916-9N	10 - 12	3TJ-1494F-11	10 - 20
5TA-11133-10	1 - 3	3LD-12168-U1	3 - 13	5BE-13447-20	8 - 2	5TJ-14453-L0	9 - 13	5TJ-14916-9P	10 - 12	4JT-1494F-11	10 - 22
5TA-11134-10	1 - 4	3LD-12168-W1	3 - 13	2S2-13597-00	9 - 1	5NY-14455-20	9 - 15	5TJ-14916-9R	10 - 12	3TJ-1494F-12	10 - 20
5TJ-11166-10	1 - 21	3LD-12168-Y1	3 - 13	5TJ-14101-E0	10 - 1	5TJ-14458-00	9 - 20	5TJ-14916-9S	10 - 12	3TJ-1494F-13	10 - 20
3P6-11167-00	1 - 20	3LD-12169-11	3 - 13	5TJ-14101-L0	10 - 1	5TJ-14459-01	9 - 14	5TJ-14916-9T	10 - 12	4JT-1494F-13	10 - 22
5TJ-11167-10	9 - 42	3LD-12169-31	3 - 13	5NL-14105-00	10 - 23	5UM-14462-E0	9 - 30	5TJ-14916-A1	10 - 12	3TJ-1494F-14	10 - 20
2S2-11181-00	1 - 14	3LD-12169-50	3 - 13	4MX-14115-00	10 - 50	5TJ-14475-00	9 - 18	5TJ-14916-AM	10 - 12	3TJ-1494F-15	10 - 20
2S2-11190-20	1 - 17	3LD-12169-70	3 - 13	3TJ-14137-40	9 - 9	5JG-14521-00	10 - 14	5TJ-14916-AN	10 - 12	5UM-1494F-29	10 - 22
2S2-11193-00	1 - 23	3LD-12169-90	3 - 13			5JG-14522-00	10 - 7	5TJ-14916-AP	10 - 12	5JG-14951-00	10 - 6
5UM-1119E-00	1 - 19	3LD-12169-E0	3 - 13	5BE-14146-00	10 - 52	5JG-14531-00	10 - 59	5TJ-14916-AR	10 - 12	5GS-14958-00	10 - 63
2S2-11311-10	1 - 24	3LD-12169-G0	3 - 13	5PA-14146-00	10 - 61	3TJ-14536-40	10 - 32	5TJ-14916-AS	10 - 12	5JG-14959-00	10 - 2
2S2-11351-00	1 - 25	3LD-12169-J0	3 - 13	5TA-14155-00	10 - 40	5JG-14546-01	10 - 10	5TJ-14916-AT	10 - 12	5JG-14984-00	10 - 28
5TJ-11400-21	2 - 1	3LD-12169-L0	3 - 13	633-14159-00	10 - 27	676-14548-00	10 - 25	5TJ-14916-LU	10 - 12	4SR-14985-00	10 - 24
5TJ-11412-20	2 - 2	3LD-12169-N0	3 - 13	3TJ-14159-40	10 - 13	4MX-14561-00	10 - 49	5TJ-14916-NT	10 - 12	5TA-14987-00	9 - 8
2S2-11422-00	2 - 3	3LD-12169-T0	3 - 13	5XC-14171-00	10 - 35	6H4-14561-00	10 - 34	5XC-14922-00	10 - 43	5TJ-14987-00	10 - 56
2S2-11454-00	2 - 14	5TJ-12170-00	4 - 1	3TJ-14191-40	10 - 29	5NX-14562-00	10 - 47	5GS-14933-00	10 - 64	5TA-14991-00	10 - 38
2S2-11455-00	2 - 9	5TJ-12180-30	4 - 2	5UL-14196-00	10 - 54	3TJ-14564-40	10 - 67	5GS-14933-40	10 - 33	4FN-14997-00	10 - 11
2S2-11464-00	2 - 16	5TA-12210-10	4 - 5	5TA-14197-00	10 - 55	5JG-14565-00	10 - 58	5TA-14934-00	10 - 45	5TA-14997-00	10 - 41
2S2-11531-00	2 - 11	4FM-12213-00	4 - 6			5TJ-14591-10	10 - 60	5GS-14940-00	10 - 62	2S2-15100-11	13 - 1
2S2-11536-00	2 - 8	5BE-12241-00	1 - 18	5UM-14197-00	10 - 68	5TJ-14591-20	10 - 60	5JG-14940-17	10 - 31	2S2-15155-10	13 - 2
5JG-11603-00	2 - 22	2S2-12251-00	4 - 9	2S2-14208-00	10 - 39	688-14592-00	10 - 4	5JG-14940-18	10 - 31	3Y1-15363-10	14 - 6
2S2-11631-20	2 - 21	5TA-12252-00	4 - 10	5NX-14216-00	10 - 48	5TJ-14611-10	12 - 1	5JG-14940-19	10 - 31	2S2-15364-00	13 - 27
5TA-11633-00	2 - 23	5TJ-12299-00	4 - 11	5TA-14227-00	9 - 6	3VD-14613-01	12 - 6	5TA-14943-15	10 - 21	5XC-15373-00	13 - 3
2S2-11651-00	2 - 6	5TJ-1240A-E0	6 - 1	5TA-14239-00	9 - 7	5TJ-14623-00	12 - 11	4MX-14943-39	10 - 18		14 - 21
5TG-11681-01	2 - 4	5BE-12422-20	5 - 7	5TA-14261-00	10 - 53	5TA-14628-00	12 - 2	4MX-14943-40	10 - 18	4JT-15381-01	13 - 13
5TA-12111-00	3 - 1	5BE-12439-00	5 - 8	5JG-14264-00	10 - 16	5TJ-14710-E0	12 - 8	4MX-14943-41	10 - 18	5BE-15383-01	13 - 14
5TA-12112-00	3 - 2	5UM-1244J-E0	23 - 28	3TJ-14267-40	10 - 9	5PH-14714-00	12 - 15	4MX-14943-42	10 - 18	2S2-15388-00	13 - 17
5TJ-12113-00	3 - 5	5DJ-12451-00	5 - 2	5JG-14275-00	10 - 15	5BE-14747-00	12 - 16	4MX-14943-43	10 - 18	5TJ-15411-30	14 - 1
5TJ-12114-00	3 - 6	5GR-12458-00	5 - 1	5TJ-14291-00	9 - 2	4BD-14766-00	12 - 3	4MX-14943-44	10 - 18	5TA-15415-20	14 - 26
4GY-12117-00	3 - 8	2S2-12461-70	6 - 5	5TA-14293-00	9 - 5	5TJ-14780-00	12 - 9	4MX-14943-90	10 - 18	2S2-15421-10	13 - 8
5BE-12117-00	3 - 7	22W-12462-00	6 - 9	3TJ-14293-40	10 - 30	5TJ-14784-00	12 - 10		10 - 18	2S2-15431-00	14 - 17
1AA-12118-00	3 - 9	2S2-12464-70	6 - 2	5TA-14335-00	10 - 37	5BE-14788-00	12 - 18	4MX-14943-91	10 - 18	5TA-15441-01	13 - 32
1WG-12118-00	3 - 10		6 - 6	5JG-14346-00	10 - 57	5TJ-14799-00	12 - 13	4MX-14943-92	10 - 18	2S2-15451-00	14 - 8
33M-12119-00	3 - 11	2S2-12481-00	6 - 12	5TA-14371-00	10 - 36	5UM-14803-00	11 - 6	4MX-14943-93	10 - 18	5TA-15453-00	14 - 27
4SV-12119-00	3 - 12	1C3-12482-00	6 - 16	5JG-14379-00	10 - 42	5TJ-14815-00	11 - 2	4MX-14943-94	10 - 18	2S2-15462-10	14 - 22
5TA-12121-00	3 - 3	2S2-12482-00	6 - 19	2S2-14388-00	10 - 8	5TJ-14834-E0	11 - 7	5TJ-14947-00	10 - 17	5TJ-1549B-20	14 - 14
3GM-12126-00	3 - 4	5BE-12564-00	5 - 12	4MX-14392-00	10 - 26	5TJ-14871-10	11 - 1	4MX-14948-05	10 - 19	5TG-15515-01	16 - 6
3FV-12153-10	3 - 14	2S2-12576-00	6 - 15	5UM-14401-E0	9 - 12	5TJ-14881-10	11 - 4		10 - 19	5TJ-15517-00	16 - 5
3LD-12168-00	3 - 13	2S2-12578-00	6 - 17	5UM-14417-E0	9 - 26	5TJ-14882-10	11 - 10	4MX-14948-06	10 - 19	4GY-15521-00	16 - 4
3LD-12168-20	3 - 13	5TJ-12579-E0	6 - 18	5TJ-14419-00	9 - 32	5BF-14916-81	10 - 12		10 - 19	5TJ-15560-20	16 - 1
3LD-12168-40	3 - 13	583-13113-00	14 - 32	5UM-1441A-E0	9 - 34	5BF-14916-8N	10 - 12	4MX-14948-07	10 - 19	5UM-15570-00	16 - 7
3LD-12168-60	3 - 13	353-13115-01	1 - 2	5UM-1441G-E0	9 - 19	5BF-14916-8P	10 - 12	4MX-14948-08	10 - 19	5VY-15586-00	16 - 8
3LD-12168-80	3 - 13	2S2-13300-10	7 - 1	5UM-14437-E0	9 - 23	5BF-14916-8R	10 - 12	4MX-14948-09	10 - 19	2S2-15601-00	15 - 1
3LD-12168-A0	3 - 13	5TA-13320-00	7 - 2	5UM-1443A-E0	9 - 25	5BF-14916-8S	10 - 12	4JT-1494F-01	10 - 22	2S2-15620-01	15 - 18
3LD-12168-F0	3 - 13	2S2-13341-00	7 - 9	5UM-1443B-L0	9 - 33	5BF-14916-8T	10 - 12	4JT-1494F-03	10 - 22	5XD-15621-00	15 - 19
3LD-12168-H1	3 - 13	2S2-13342-00	7 - 7	5BF-1443E-00	9 - 28	5BF-14916-8U	10 - 12	4JT-1494F-05	10 - 22	5TA-15651-00	15 - 15
3LD-12168-K1	3 - 13	5BE-13411-00	7 - 13	5NY-14442-00	9 - 16	5TJ-14916-91	10 - 12	4JT-1494F-07	10 - 22	5GR-15664-00	15 - 8

NUMERICAL INDEX

PART NO.	REF. NO.	PART NO.	REF. NO.	PART NO.	REF. NO.	PART NO.	REF. NO.	PART NO.	REF. NO.	PART NO.	REF. NO.
5SG-15668-00	15 - 11	5PA-2118K-00	22 - 25	5TJ-21757-00	9 - 37	5NY-22475-00	25 - 16	5UM-23170-E0	27 - 10	5TJ-2510C-80	30 - 12
2S2-15671-00	15 - 4	5PA-2118K-10	22 - 26	4XV-2177L-01	9 - 21	5UN-22898-60	33 - 11		27 - 31	5NG-25111-50	30 - 1
214-15686-00	15 - 12	5UM-21190-E0	21 - 5	5UM-21860-E0	23 - 24	1C3-22969-90	24 - 11	5XE-23171-L0	27 - 4	5NY-25117-00	30 - 3
2S2-16111-60	17 - 1	1C3-21244-10	28 - 28	26H-21874-00	23 - 26	5TJ-23102-E0	27 - 1		27 - 25	1C3-25181-10	30 - 11
5XD-16150-60	17 - 4	5UM-21268-E0	21 - 41	26H-21875-00	23 - 25	5TJ-23102-F0	27 - 1	5TJ-2317E-U0	26 - 21	5GS-25304-00	32 - 9
5XD-16154-00	17 - 11	5UM-21288-E0	44 - 19	1C3-22110-90	24 - 1	5TJ-23103-E0	27 - 22	5DH-23183-00	25 - 8	5TJ-2530S-80	32 - 19
5TA-16321-00	17 - 8	1C3-2135F-00	24 - 34	5XC-22121-91	24 - 30	5TJ-23103-F0	27 - 22	509-23184-L0	25 - 6	5ET-25311-00	32 - 1
1TA-16325-00	17 - 12	1C3-2139R-00	24 - 35	1C3-22122-00	24 - 31	5TJ-23110-C0	27 - 24	5NY-23188-L0	27 - 14	5ET-25317-00	32 - 2
4X7-16325-00	17 - 7	2S2-21417-00	21 - 30	2S2-22128-70	24 - 13	5XE-23111-L0	27 - 18		27 - 35	4XM-25364-00	32 - 14
5JG-16351-00	17 - 6	2S2-21425-70	21 - 23	1C3-22141-10	24 - 17		27 - 39	5TJ-2331E-80	26 - 16	1C3-25381-90	32 - 24
5JG-16356-00	17 - 15	2S2-21426-70	21 - 24	2S2-22151-70	24 - 10	5XE-23117-L0	27 - 19	5TJ-23340-M0	27 - 43	1C3-25388-H0	32 - 20
2S2-16357-00	17 - 20	5UM-21447-E0	21 - 2	5UN-22176-00	25 - 13		27 - 40	3SP-23356-L0	27 - 50	1C3-25389-H0	32 - 21
5TA-16371-10	17 - 5	1C3-21448-10	21 - 3	30X-22178-00	21 - 8	5TJ-23120-C0	27 - 3	5XE-23364-00	45 - 3	3JE-25394-00	32 - 13
5TJ-16381-20	17 - 21	5XC-21456-90	21 - 33	3JD-22178-20	21 - 13	5XE-23125-L0	27 - 5	5TJ-23389-80	26 - 18	5SF-25394-00	30 - 10
5TJ-17121-20	18 - 9	5UM-2147A-E0	21 - 34	5XC-2217A-90	24 - 20		27 - 26	5XE-23393-L0	27 - 12	1C3-25447-00	32 - 15
5TJ-17131-20	18 - 6	5TJ-21485-E0	21 - 37	5XC-2217F-90	24 - 26	3JD-2312G-L0	27 - 21		27 - 33	1C3-25448-00	32 - 15
5TJ-17141-20	18 - 7	5UM-21486-E0	21 - 36	4V4-22184-00	21 - 9		27 - 42	5TJ-2339E-00	41 - 11	5GS-25448-50	32 - 15
5TJ-17151-20	18 - 3	1C3-21511-51	22 - 1	5MV-22184-00	25 - 14	5TJ-23136-C0	27 - 2	4EW-23416-00	26 - 3	1C3-25449-00	32 - 15
5TJ-17211-20	18 - 14	4XL-2153A-10	27 - 47	5UM-22199-E0	24 - 12		27 - 23	5UM-23435-E1	26 - 6	1C3-25450-00	32 - 15
5TJ-17221-20	18 - 25		27 - 49	5TJ-22201-20	25 - 2	5TJ-23141-00	45 - 2	18P-23441-00	26 - 9	5TJ-25450-80	32 - 15
5TJ-17231-20	18 - 20	5UM-2153E-00	22 - 27	5TJ-22201-F0	25 - 2	5TJ-23141-10	45 - 2	17D-23442-00	26 - 10		32 - 15
5TJ-17241-20	18 - 23	5UM-21610-E0	22 - 7	5TJ-22201-G0	25 - 2	5TJ-23141-20	45 - 2	5XC-23466-L0	27 - 51	1C3-25451-00	32 - 15
5TJ-17251-20	18 - 17	5TJ-21610-U0	22 - 7	5TJ-22210-21	25 - 1	5TJ-23141-30	45 - 2	5XC-23467-L0	27 - 52	1C3-25452-00	32 - 15
2S2-17402-00	18 - 13	5XE-21635-10	22 - 8	5TJ-22210-F1	25 - 1	5TJ-23141-40	45 - 2	5TJ-23525-C0	27 - 45	5TJ-25452-80	32 - 15
5TJ-17411-20	18 - 2	5TA-21642-00	22 - 22	5TJ-22210-G1	25 - 1	5TJ-23141-50	45 - 2	5UM-23591-E0	40 - 15	5CG-25715-00	35 - 10
5NG-17460-00	18 - 31	5TJ-2164F-U0	22 - 10	5UN-22212-00	45 - 1	5TJ-23141-60	45 - 2	5UM-24110-E1	28 - 1		37 - 9
5TJ-17460-00	18 - 31	5TJ-2164G-U0	22 - 11	5UN-22212-10	45 - 1	5TJ-23141-L0	27 - 17	5TJ-24110-J0	28 - 1	1C3-25718-50	33 - 18
2S2-17466-00	13 - 9	3RV-21668-A0	24 - 36	5UN-22212-20	45 - 1		27 - 38	4EW-2412F-00	28 - 16	1C3-2580T-00	31 - 3
	13 - 9	3RV-21668-B0	24 - 37	5UN-22212-30	45 - 1	5XE-23142-L0	27 - 11	5XE-24144-00	28 - 6	1C3-2580W-72	33 - 3
5TJ-17466-00	13 - 9	5UM-21711-E0	23 - 1	5UN-22212-40	45 - 1		27 - 32	3FB-2415E-02	22 - 4	2S2-2581T-70	31 - 1
2S2-17471-00	18 - 34	5UM-21717-E0	23 - 2	5UN-22212-50	45 - 1	5XE-23144-L0	27 - 9	3FB-2415E-12	22 - 5	5UN-25827-60	33 - 10
2S2-18101-00	20 - 1	5XC-21719-90	23 - 7	5UN-22212-60	25 - 17		27 - 30	3PT-2416E-10	22 - 6	5UN-25828-60	33 - 9
5XC-18110-00	20 - 7	5UM-21721-E0	23 - 5		45 - 1	1C3-23145-L0	27 - 7	5UM-24181-E0	28 - 18	2S2-2582W-70	33 - 1
5MW-18122-01	20 - 2	2S2-2172A-80	23 - 23	5UN-22212-70	45 - 1		27 - 28	5XC-24182-90	28 - 25	5MV-25833-00	35 - 16
2S2-18140-10	19 - 6	5TJ-2172A-E0	23 - 17	3SP-22213-00	25 - 4	5XE-23146-L0	27 - 6	5XC-24183-90	28 - 26	17D-2583V-00	37 - 1
5TJ-18172-00	20 - 15	5UM-2172S-E0	23 - 8	5XE-22214-00	25 - 18		27 - 27	3DH-24186-00	28 - 11	5DH-25849-00	31 - 15
3XJ-18173-10	20 - 10	5UM-21730-E0	23 - 12	5MV-22224-00	25 - 9	5NY-23147-L0	27 - 15	5XC-2419A-90	28 - 12	5MV-25852-01	35 - 8
3XJ-18178-00	20 - 11	1HB-2173E-00	23 - 13	4JX-22226-00	25 - 7		27 - 36	5TJ-24311-E0	28 - 21	5UN-25852-50	37 - 5
3XJ-18182-00	20 - 12	1HB-2173F-00	23 - 19	3SP-22234-00	25 - 3	1C3-2314F-M0	27 - 20	5TJ-24311-J0	28 - 21	5XE-25853-00	35 - 11
3XJ-18184-00	20 - 14	5UM-2173S-E0	23 - 9	5NY-22241-00	25 - 22		27 - 41	5XC-24339-90	28 - 14	5UN-25854-00	37 - 7
2S2-18185-00	20 - 17	5UM-21740-E0	23 - 18	5XE-22242-00	25 - 19	5XE-23153-L0	27 - 8	3XJ-24380-00	28 - 4	5XE-25854-00	35 - 7
34P-18501-00	19 - 10	5UM-2174A-E0	23 - 6	5MV-22253-00	25 - 15		27 - 29	5UN-24500-E0	28 - 19	5UN-2585B-00	37 - 6
2S2-18502-00	19 - 11	1HB-2174G-00	23 - 14	1C3-22253-50	25 - 10	4SS-23158-L0	27 - 16	1P6-24512-00	28 - 20	5CG-2585G-00	37 - 10
34P-18503-00	19 - 12	1HB-2174H-00	23 - 20	4AA-22259-40	25 - 5		27 - 37	5NY-24610-00	28 - 2	5MV-25867-00	35 - 15
5NL-18541-00	19 - 1	1HB-2174J-00	23 - 15	4AA-22259-60	25 - 5	1C3-2315H-10	27 - 48	5UM-2470F-T0	29 - 2	5NY-25868-00	35 - 6
278-18542-00	19 - 3	1HB-2174K-00	23 - 21	1P8-22355-00	24 - 3	5TJ-2315J-C0	27 - 46	5UM-24710-T0	29 - 1	5TJ-25872-80	35 - 1
2S2-18562-00	13 - 18	5UM-2174T-E0	22 - 9	4EW-22474-00	25 - 12	5TJ-2316A-F0	27 - 13	5UM-24723-E0	29 - 3	5XC-25873-L0	37 - 12
5TJ-21101-E0	21 - 1	2TK-21757-00	9 - 36	3JE-22475-00	25 - 11		27 - 34	5NY-25104-00	30 - 6	1C3-25875-50	31 - 17

NUMERICAL INDEX

PART NO.	REF. NO.	PART NO.	REF. NO.	PART NO.	REF. NO.	PART NO.	REF. NO.	PART NO.	REF. NO.	PART NO.	REF. NO.
1C3-25876-50	37 - 17	3FV-28386-00	9 - 35	5UM-84330-E0	41 - 4	90105-06107	26 - 19	90149-06068	7 - 8	90201-08048	32 - 18
1C3-25886-50	37 - 15	5TJ-81410-50	38 - 1	5BF-84334-00	41 - 8		28 - 8	90149-06074	13 - 16	90201-08061	12 - 21
5MV-2589F-00	35 - 13	5TJ-81450-30	38 - 2	5UM-84340-E1	41 - 3		33 - 21	90149-06083	2 - 15	90201-08410	10 - 44
5UN-25914-00	33 - 16	5TJ-81528-00	38 - 3	5UM-84710-E0	42 - 1	90105-06108	33 - 2	90149-06108	28 - 24	90201-08512	5 - 3
5DH-25914-50	33 - 14	5TJ-81801-00	39 - 2	5UM-84716-E0	42 - 4	90105-06110	33 - 19	90149-10031	21 - 4	90201-10025	1 - 16
3SP-25914-51	31 - 12	5TJ-81828-01	39 - 7	5TJ-84716-U0	42 - 4		40 - 6	90151-04003	24 - 2	90201-10032	36 - 15
5DH-25916-00	31 - 10	5TJ-8183G-30	39 - 6	5UM-84736-E0	42 - 2		44 - 20	90151-06051	31 - 2	90201-10045	21 - 21
	33 - 13	50W-81846-M1	39 - 4	5UM-84737-E0	42 - 3	90105-06111	6 - 27	90151-06071	13 - 15		21 - 26
3JD-25917-00	31 - 13	5TJ-81890-30	39 - 1	5TJ-84781-U0	42 - 5		28 - 9	90152-06010	15 - 22		21 - 29
	33 - 15	5TJ-81940-12	44 - 26	4AG-85111-00	26 - 22		33 - 22	90154-05022	44 - 6		36 - 20
5DH-25919-00	31 - 6	5UM-81950-E0	44 - 31	3Y6-85130-02	22 - 14	90105-06127	20 - 8	90157-04005	41 - 6	90201-105A8	16 - 2
5DH-25919-50	33 - 6	5UM-81952-E0	44 - 30		42 - 8		22 - 16	90159-06092	17 - 10	90201-12020	38 - 7
8CR-25924-00	33 - 12	5UM-81960-E0	44 - 18	5TJ-85540-E0	44 - 1	90105-06189	13 - 10	90160-05012	42 - 10	90201-12166	7 - 11
3SP-25926-51	31 - 11	4WA-81980-00	44 - 17	5TJ-85540-F0	44 - 1	90105-08133	21 - 16	90170-10405	2 - 18	90201-125L6	17 - 17
5DH-25933-00	31 - 9	5TJ-81980-00	44 - 16	5TJ-85540-L0	44 - 1	90105-08134	26 - 14	90170-14171	2 - 12	90201-127E1	20 - 5
1UY-25937-51	31 - 14	5TJ-82100-01	44 - 21	5UM-85546-E0	44 - 2		27 - 44	90170-20327	17 - 14	90201-14020	24 - 32
	33 - 17	5TJ-82115-00	44 - 24	5XC-85885-00	10 - 46	90105-08137	12 - 20	90201-24003	26 - 7	90201-15701	14 - 19
5XC-26111-L1	34 - 1	5TJ-82116-E0	44 - 25	5NY-W0041-00	35 - 5		31 - 16	90179-06028	24 - 15	90201-16018	24 - 19
5XC-26124-90	34 - 11	5SL-82119-10	44 - 28	5UN-W0042-50	37 - 2	90105-08143	21 - 31	90179-08019	32 - 23	90201-162H4	15 - 10
5XC-26143-L0	34 - 12	8CY-82131-00	44 - 23	5MV-W0045-01	31 - 8	90105-08154	26 - 13	90179-10658	21 - 20	90201-167P7	15 - 6
5TJ-26240-C0	34 - 3	42X-82151-00	44 - 27	1C3-W0046-B0	33 - 8	90105-08156	21 - 6		21 - 28	90201-20020	32 - 26
4GY-26241-00	34 - 2	5UM-82176-E0	44 - 22	3JD-W0047-00	31 - 5	90105-08307	12 - 19	90179-12657	38 - 6	90201-203E7	18 - 16
5BE-26281-00	34 - 4	5TA-82310-10	44 - 3	5UN-W0047-50	33 - 5		21 - 7	90179-16011	30 - 13	90201-20685	15 - 2
5BE-26282-00	34 - 5	5UM-8235Y-E0	44 - 33	1UY-W0048-50	31 - 7	90105-10163	1 - 15	90179-20001	18 - 33		15 - 16
5SF-26287-10	34 - 7	5UM-82510-E1	44 - 32		33 - 7	90105-10176	21 - 27	90179-20009	17 - 3	90201-21014	24 - 25
5UM-26302-E0	34 - 8	5TJ-82540-01	44 - 4	5UN-W0057-00	31 - 4	90105-10189	21 - 22	90179-28013	26 - 4	90201-24016	26 - 8
5UM-26334-E0	43 - 12	5TJ-82590-E0	44 - 15	5UN-W0057-50	33 - 4	90105-10191	21 - 25	90183-060A6	6 - 4	90201-253K0	18 - 4
5TJ-26335-E0	34 - 9	5TJ-82590-F0	44 - 15	5XE-W2587-10	35 - 4	90105-10193	21 - 19		6 - 8		18 - 21
5HD-26337-00	43 - 5	5TJ-82911-80	43 - 1	90101-06041	20 - 16	90109-06034	43 - 3	90185-08008	32 - 17	90201-286K9	26 - 5
5TA-26339-00	43 - 17	5XD-82913-00	43 - 10	90101-06044	15 - 13	90109-06198	19 - 8	90185-08009	21 - 17	90202-05193	28 - 23
1C3-26342-50	34 - 10	5TJ-82917-02	43 - 7	90101-08006	32 - 22	90109-06245	9 - 41	90185-10012	25 - 23	90202-08045	10 - 5
5NY-26372-00	35 - 17	5XD-82946-00	43 - 9	90105-05016	26 - 17	90109-08078	32 - 16	90185-10018	36 - 23	90206-06090	12 - 5
5TJ-26372-80	43 - 8	5TJ-83500-F0	40 - 1	90105-06027	1 - 5	90109-10026	36 - 19	90185-14010	24 - 33	90208-25045	17 - 2
2S2-27200-11	36 - 1	5TJ-83500-G0	40 - 1	90105-06064	23 - 16	90110-05038	9 - 10	90185-16002	24 - 18	90209-16011	24 - 24
5UN-27217-00	37 - 8	5UM-83519-E0	40 - 5		23 - 22	90110-05041	12 - 12	90185-20002	32 - 25	90209-21332	18 - 10
1C3-27217-10	36 - 2	5UM-83595-E0	40 - 13		41 - 10	90110-06228	8 - 5	90201-04018	22 - 12		18 - 19
5UN-27218-00	37 - 3	5TJ-83755-C0	40 - 7	90105-06081	13 - 19	90110-06248	38 - 5	90201-047R8	42 - 6	90209-26348	18 - 24
5UN-27222-00	37 - 4	5TJ-8375E-C0	40 - 11		18 - 35	90110-08087	15 - 24	90201-05021	40 - 3	90215-10009	2 - 19
5UM-27311-E0	36 - 16	5TJ-8375F-C0	40 - 9	90105-06100	22 - 17	90110-08097	12 - 7	90201-06013	19 - 9	90215-14287	2 - 13
5UM-27315-E0	36 - 22	5TJ-83912-80	43 - 2	90105-06103	23 - 3	90111-06116	37 - 11	90201-06032	22 - 18	90215-20005	17 - 13
5XC-27411-M1	36 - 9	1C3-83922-50	35 - 12		23 - 10	90116-08022	1 - 11	90201-06084	22 - 23	90215-21003	18 - 32
5XC-27421-M1	36 - 10	5TA-83941-00	43 - 11	90105-06104	24 - 14	90119-06146	23 - 27	90201-06084	28 - 10	90240-08120	36 - 6
1C3-27491-50	33 - 20	5HD-83951-00	43 - 6	90105-06105	11 - 9	90119-06147	22 - 3	90201-06571	6 - 28	90240-10004	36 - 11
5XC-28116-00	21 - 40	5UM-83976-E2	43 - 18		24 - 16	90119-06166	21 - 35		22 - 20	90249-05004	9 - 39
5TA-2814F-00	21 - 39	5UM-83976-F2	43 - 19		31 - 18	90119-08095	23 - 4	90201-08043	21 - 18	90249-05005	9 - 38
5ET-28166-10	21 - 38	5LP-84126-10	43 - 4		40 - 14		23 - 11	90201-08044	36 - 7	90267-40129	22 - 13
5PG-2816R-00	22 - 28	5UM-84310-E1	41 - 1	90105-06106	22 - 19	90149-05024	38 - 4	90201-08045	21 - 10	90267-48084	42 - 7
5UM-2831V-E0	26 - 15	5VM-84314-00	41 - 2	90105-06107	11 - 8	90149-05162	43 - 16	90201-08047	15 - 25	90280-03006	2 - 20

NUMERICAL INDEX

PART NO.	REF. NO.	PART NO.	REF. NO.	PART NO.	REF. NO.	PART NO.	REF. NO.	PART NO.	REF. NO.	PART NO.	REF. NO.
90282-05034	2 - 17	90461-10136	13 - 29	91312-06030	13 - 24	93210-19758	5 - 13	9383E-14215	18 - 31	97702-50016	42 - 10
90338-07043	9 - 22	90464-06004	44 - 34	91312-06050	13 - 5	93210-21001	44 - 5	94108-21015	30 - 7	97702-50516	9 - 24
90340-12007	1 - 6	90464-11M18	42 - 11	91312-06060	13 - 6	93210-22164	18 - 30	94111-18012	32 - 10		9 - 27
90340-14003	14 - 4	90464-13073	44 - 10	91312-06065	8 - 6	93210-25711	39 - 5	94212-18188	32 - 11		9 - 31
90340-27003	14 - 2	90464-13077	44 - 7	91312-06080	13 - 7	93210-27370	14 - 3	94227-21101	30 - 8		41 - 5
90387-06009	22 - 21	90464-15152	44 - 8	91314-06016	11 - 3	93210-44678	39 - 3	94309-18146	32 - 12	97702-60016	22 - 24
90387-06065	6 - 26	90464-15195	44 - 12	91316-04012	10 - 3	93210-47675	8 - 3	94309-21161	30 - 9	98502-04010	10 - 65
	28 - 15		44 - 12	91402-20012	36 - 4	93210-58346	14 - 15	94416-21018	30 - 5	98502-05010	37 - 16
90387-06090	22 - 2	90464-16061	44 - 11	91402-25015	36 - 12	93300-60839	21 - 14	94421-18008	32 - 8	98507-05020	34 - 6
	28 - 13	90464-23041	44 - 14	91808-16023	1 - 7	93304-20310	2 - 10	94591-57118	4 - 4	98702-06025	28 - 17
90387-06104	26 - 20	90465-13152	44 - 13	91812-16001	14 - 23	93306-00105	5 - 6	94681-76021	32 - 28	98706-04012	35 - 9
90387-08041	21 - 11	90465-13275	28 - 27	91A20-05140	6 - 10	93306-00426	18 - 12	94701-00411	1 - 13	98980-06008	12 - 4
90387-08081	12 - 17		44 - 9	92012-05008	12 - 14	93306-00431	18 - 11	95022-06008	44 - 29	99002-04600	9 - 40
90387-086N4	21 - 15	90467-07138	11 - 14		40 - 12	93306-07202	32 - 4	95022-06010	1 - 8	99009-12400	7 - 10
90387-1003G	36 - 21	90467-09006	11 - 15	92012-05012	43 - 14	93306-20532	18 - 1	95022-06012	6 - 20	99009-16400	15 - 7
90387-124F4	20 - 3	90467-090A2	6 - 11	92012-06010	6 - 3	93306-205A5	18 - 27		13 - 30	99009-20400	15 - 17
90387-14009	24 - 29		23 - 29		6 - 7	93306-27212	32 - 3	95022-06016	13 - 33	99009-20500	17 - 24
90387-16025	24 - 23	90467-100A1	28 - 22	92012-06012	40 - 16	93306-30633	2 - 7		14 - 16	99009-22500	14 - 20
90387-18004	24 - 9	90467-140A4	11 - 11	92902-04100	10 - 66	93306-80502	19 - 5	95022-06020	14 - 13	99009-45500	32 - 7
90387-18007	13 - 22	90467-16063	11 - 5	92902-06600	40 - 17	93306-90409	30 - 2	95022-06025	4 - 7	99530-08012	7 - 5
90387-18012	24 - 8	90467-160A4	1 - 22	92902-08200	21 - 32	93306-90509	19 - 2		39 - 8	99530-08016	14 - 9
90387-20028	18 - 15		9 - 45	92902-10200	25 - 21	93310-212F6	16 - 3	95022-06030	5 - 11		14 - 28
90387-21005	18 - 8	90467-17089	9 - 29		26 - 11	93310-63417	2 - 5		7 - 14	99530-10114	7 - 15
90387-2513F	18 - 29		9 - 46	93101-14164	14 - 18	93315-32166	24 - 21		14 - 12		13 - 20
90387-28012	18 - 26		11 - 12	93102-12106	5 - 5	93315-32269	24 - 27		14 - 25	99530-14016	13 - 4
90401-10172	35 - 3	90468-16001	36 - 8	93102-12224	17 - 23	93317-11287	17 - 22		14 - 29		13 - 23
	37 - 13	90480-12020	41 - 9		20 - 9	93317-22262	24 - 4	95022-06035	1 - 10	9Y58A-76113	32 - 27
90413-14001	9 - 44	90480-14012	40 - 2	93102-20108	15 - 14	93332-00068	26 - 2		1 - 27		
90430-06014	1 - 9	90480-15528	6 - 25	93102-26468	30 - 4	93332-00081	26 - 1	95022-06040	14 - 11		
	4 - 8	90480-18549	28 - 7	93102-32480	18 - 28	93340-21505	17 - 16		14 - 24		
	5 - 10	90501-043E0	14 - 34	93105-47007	40 - 8	93342-22217	24 - 5		14 - 30		
	13 - 31	90501-052G5	20 - 13	93106-22002	24 - 6	93410-20038	15 - 3	95022-06080	14 - 31		
90430-08119	13 - 26	90501-06022	19 - 4	93106-30001	32 - 5	93420-18082	2 - 24	95022-08040	21 - 12		
90430-10005	35 - 2	90501-120A3	41 - 7	93106-30045	32 - 6	93440-10085	17 - 18	95022-10016	13 - 11		
	37 - 14	90501-147A5	15 - 20	93109-11073	5 - 4	93440-10153	7 - 4	95602-05100	43 - 15		
90430-10188	13 - 12	90501-160A2	15 - 5	93109-22019	24 - 28	93440-25084	18 - 5	95602-05200	22 - 15		
90445-082K4	11 - 13	90501-237L0	17 - 9	93109-25001	24 - 22		18 - 18		42 - 9		
90445-09027	28 - 3	90506-16007	36 - 5	93109-28043	24 - 7	93440-28062	18 - 22	95602-06200	26 - 23		
90445-09220	28 - 3	90506-30005	36 - 17	93210-07135	8 - 4	93440-41178	4 - 3	95602-10200	25 - 20		
90445-09251	28 - 5	90508-26021	19 - 7	93210-08003	14 - 10	93503-08007	14 - 33		26 - 12		
90445-14009	7 - 16	90508-28015	36 - 13	93210-09165	13 - 28	93507-32009	15 - 21	95701-06500	35 - 14		
90445-217G3	36 - 18	90508-28018	36 - 14	93210-10197	13 - 21	93511-32027	17 - 19	95702-05500	40 - 4		
90450-17001	7 - 17	90508-29021	20 - 4	93210-11073	36 - 3	93603-16219	7 - 3	95702-06500	27 - 53		
90450-22001	6 - 24	90508-305B0	15 - 9	93210-14369	14 - 5	93604-10011	5 - 9	95702-08500	1 - 12		
90450-25001	6 - 23	91312-06012	6 - 13	93210-16500	6 - 14	93608-33002	20 - 6	95822-08016	13 - 25		
90450-28001	6 - 22	91312-06020	8 - 7		6 - 21	93612-16254	1 - 26	97002-05016	43 - 13		
90450-57010	9 - 4		9 - 3	93210-17570	15 - 23	9383E-13233	18 - 31	97702-40010	40 - 10		
90450-61002	9 - 11	91312-06030	7 - 6	93210-19123	14 - 7		18 - 31		42 - 12		