

YAMAHA

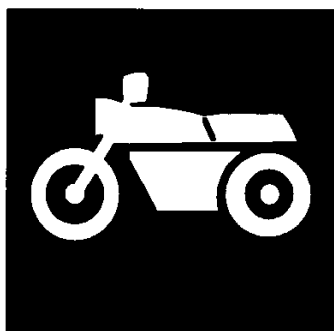

**PARTS
CATALOGUE**

YZ125K (5DH1) U.S.A., CANADA, S.AFRICA

YZ125'98 (5DH2) EUROPE

YZ125'98 (5DH3) JAPAN

YZ125K (5DH4) OCEANIA

185DH-100E1

YAMAHA
GENUINE
Parts & Accessories

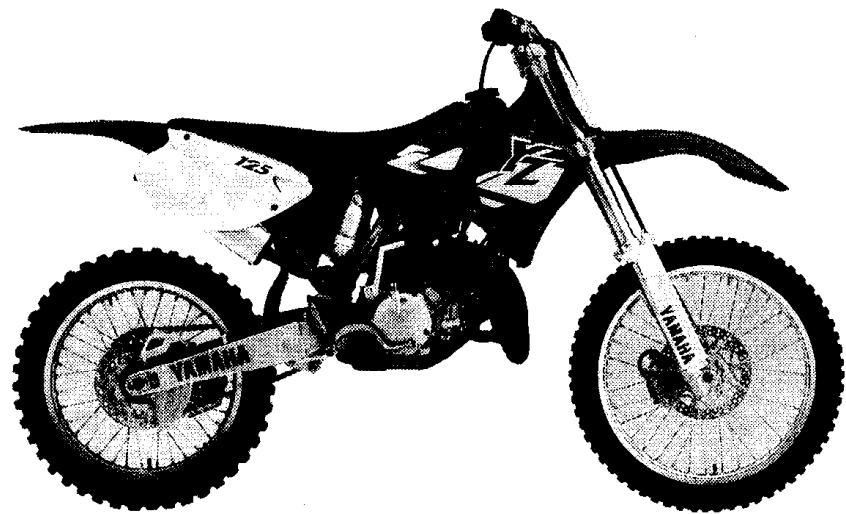

A3

FOREWORD

This Parts Catalogue is related to the parts for the model(s) in the below frame. When you are ordering replacement parts, please refer to this Parts Catalogue and quote both part numbers and part names correctly.

YZ125K(5DH1/5DH4), YZ125'98(5DH3/5DH4)

1. Modifications or additions which have been made after issue of the Parts Catalogue will be announced in the Yamaha Parts News.
It is advisable that you make necessary corrections to the Parts Catalogue according to the Yamaha Parts News.

2. Abbreviations

The following abbreviations are used in this Parts Catalogue.

- "UR" Use specified parts number.
- "UN" Use as many as needed.
- "AP" Alternate Parts
- "LM" Local Made (Parts need to be ordered locally)
- "F#" Frame No. (Applicable machine No.)

3. Parts, which are to be supplied in an assembly, are listed with a dot (.) in front of the part name as shown below.

EXAMPLE

- CARBURETOR ASSY
- . JET, PILOT
- . NOZZLE, MAIN

4. Number of component for assembly

The numeral appearing to the right of each component part indicates the quantity of parts for each assembly unit.

EXAMPLE

PART NO.	DESCRIPTION	Q'TY	REMARKS
2F5-83310-60	FRONT FLASHER LIGHT ASSY	2	
115-83311-60	. BULB (6V-18W)	1	

5. Applicable colors of graphics are represented in the "REMARKS" as shown below.

PART NO.	DESCRIPTION	Q'TY	REMARKS
2N4-24110-00-X5	FUEL TANK COMP.	1	MAXIM RED
3J1-24240-10	. GRAPHIC, FUEL TANK	1	for MXR

6. Applicable Serial No.

① Engine Serial No.

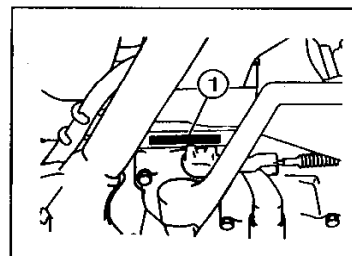

② Frame Serial No.

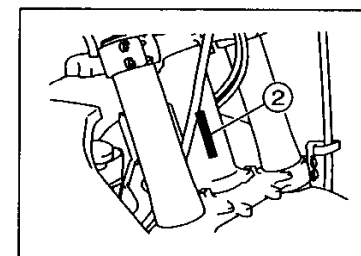

7. Note that the illustrations are for reference in finding parts numbers, not to be used for assembling. When assembling, please use the applicable service manual.

8. The asterisk (*) before a reference number indicates modification items after the first edition.

MODEL LABEL

(1) A label called "Model Label" is affixed in the location as indicated in (3) below. When using this parts catalogue, please be sure to cross-refer the "model code – production code No." in the catalogue to the "model code – production code No." indicated on the Model Label affixed onto the product concerned.

(2) "Model Label" Indication

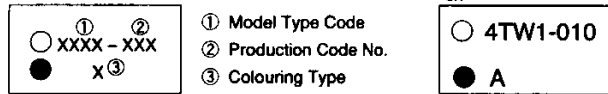

(3) Model Label Affixing Location

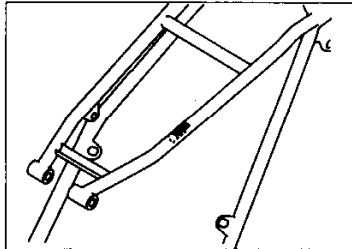

(4) Model Code – Production Code Number of Model Listed in This Parts Catalog

Model code	Production code No.	Country (destination)	Model code	Production code No.	Country (destination)
5DH1	010	U. S. A.			
	020	CANADA			
	030	S. AFRICA			
5DH2	010	FRANCE			
	020	GERMANY			
	030	SPAIN			
	040	ENGLAND			
	050	ITALY			
5DH3	010	JAPAN			
5DH4	010	AUSTRALIA			
	020	NEW ZEALAND			

(5) Colouring Information

Colouring type code	Colour code	Colour Name	Abbreviation
A	0583	DEEP PURPLISH BLUE SOLID E	DPBSE

CONTENTS

ENGINE

Cylinder Head	B2~B3
Governor	B4
Crankshaft. Piston	B5
Water Pump	B6
Radiator. Hose	B7
Intake	B8
Carburetor	B9~B10
Exhaust	B11
Crankcase	B12
Crankcase Cover 1	B13
Starter	B14
Clutch	B15
Transmission	C2~C3
Shift Cam. Fork	C4
Shift Shaft	C5

CHASSIS

Frame	C6
Fender	C7
Side Cover	C8
Rear Arm	C9~C10
Rear Suspension	C11
Steering	C12
Front Fork	C13~C14
Fuel Tank	C15
Seat	D2
Front Wheel	D3
Front Brake Caliper	D4
Rear Wheel	D5~D6

Rear Brake Caliper	D7
Steering Handle. Cable	D8
Front Master Cylinder	D9
Stand. Footrest	D10
Rear Master Cylinder	D11
Generator	D12
Handle Switch. Lever	D13
Electrical 1	D14
Alternate (Chassis)	D15
Optional Parts 1	E2

INDEX

Numerical Index	M1~M3
-----------------------	-------

FIG. 1 CYLINDER HEAD

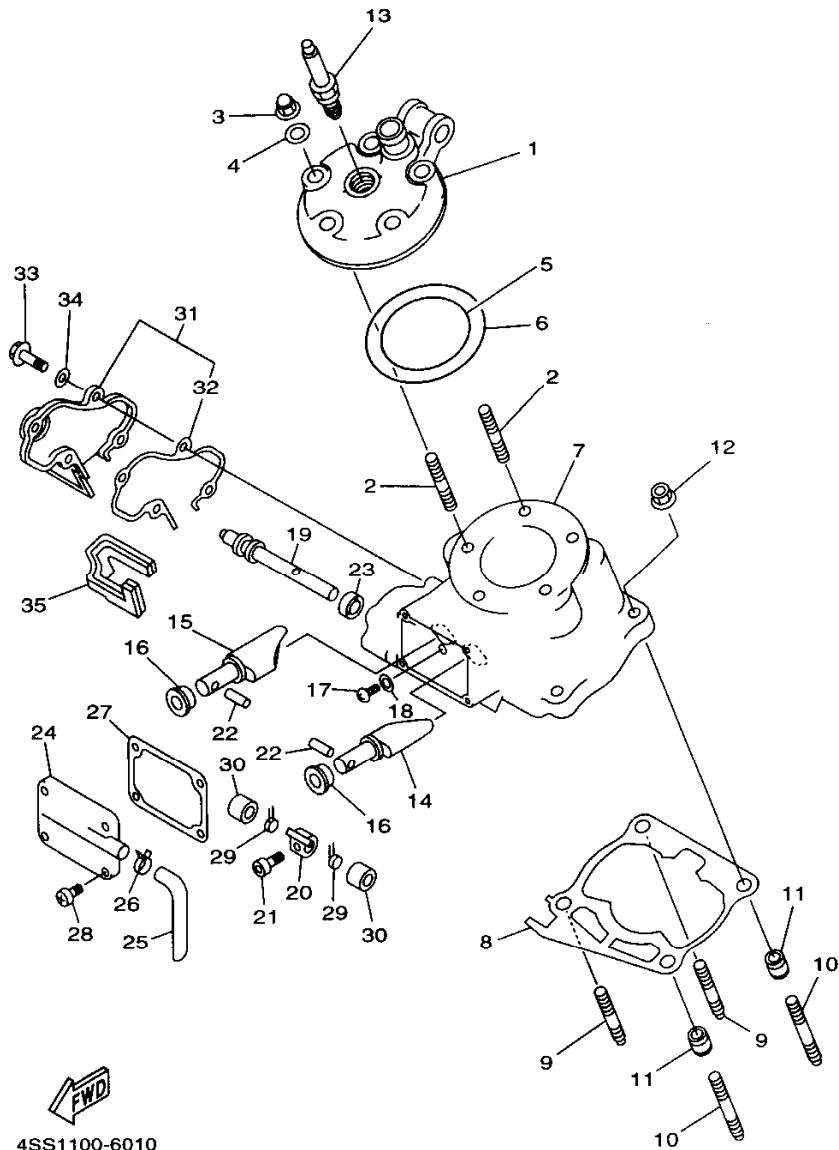

4SS1100-6010

REF. NO.	PART NO.	DESCRIPTION	5DH1	5DH2	5DH3	5DH4	REMARKS
1	4JY-11111-01	HEAD, CYLINDER 1	1	1	1	1	
2	90116-08394	BOLT, STUD	5	5	5	5	
3	90176-08026	NUT, CROWN	5	5	5	5	
4	90201-08087	WASHER, PLATE	5	5	5	5	
5	93210-63442	O-RING	1	1	1	1	
6	93210-90785	O-RING	1	1	1	1	
7	4SS-11311-10	CYLINDER 1	1	1	1	1	
8	5DH-11351-00	GASKET, CYLINDER	1	1	1	1	
9	90116-08318	BOLT, STUD	2	2	2	2	
10	90116-08388	BOLT, STUD	2	2	2	2	
11	99530-10114	PIN, DOWEL	2	2	2	2	
12	90179-08299	NUT	4	4	4	4	
13	94702-00324	PLUG, SPARK (NGK BR9EG)	1	1		1	
	94709-00324	PLUG, SPARK (NGK BR9EG)			1		
14	4SS-1131A-02	VALVE 1	1	1	1	1	
15	4SS-1132A-02	VALVE 2	1	1	1	1	
16	4JY-1131E-00	HOLDER 1	2	2	2	2	
17	98907-05010	SCREW, BIND	2	2	2	2	
18	90201-057H5	WASHER, PLATE	2	2	2	2	
19	4SS-1131V-00	SHAFT 1	1	1	1	1	
20	4SS-11832-00	LEVER, LINK	1	1	1	1	
21	91317-04008	BOLT	1	1	1	1	
22	93604-18251	PIN, DOWEL	2	2	2	2	
23	93104-08040	OIL SEAL	1	1	1	1	
24	4SS-1131M-00	COVER	1	1	1	1	
25	4JY-11166-00	PIPE, BREATHER 1	1	1	1	1	
26	90467-13062	CLIP	1	1	1	1	

B2

FIG. 1 CYLINDER HEAD

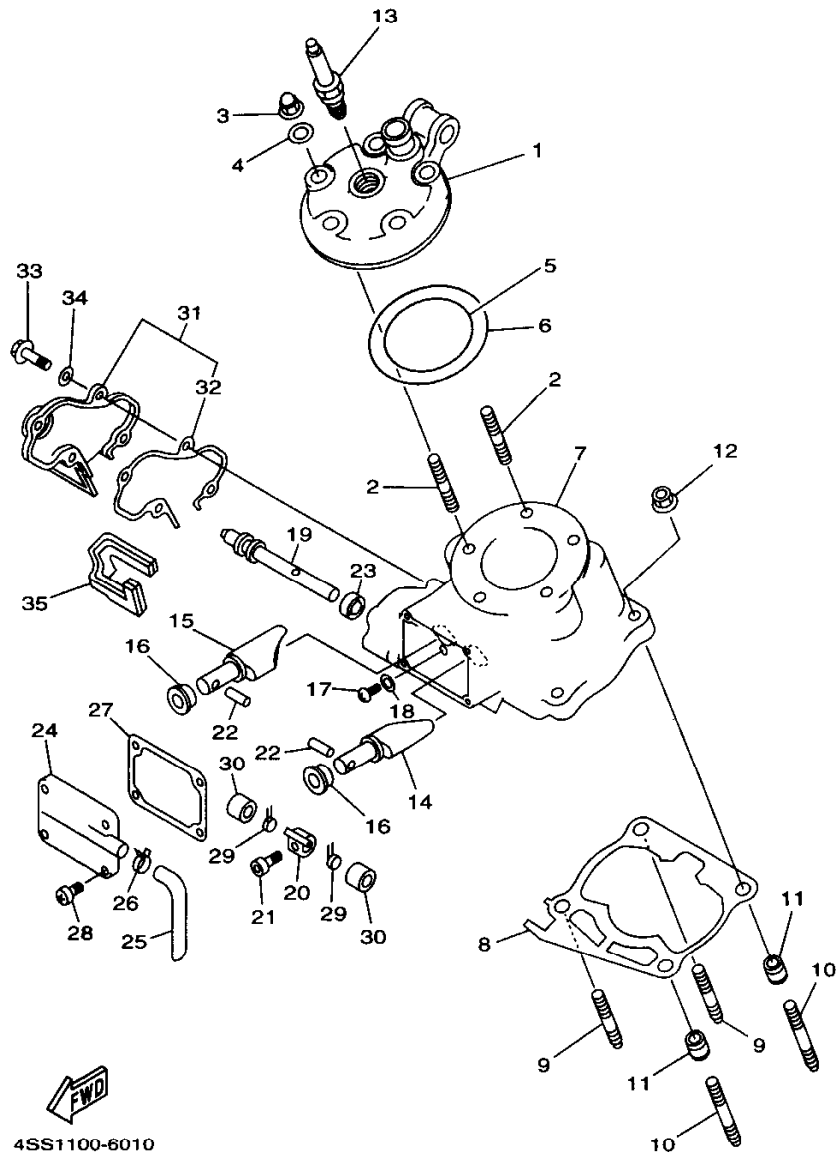

4SS1100-6010

REF. NO.	PART NO.	DESCRIPTION	SDH1	SDH2	SDH3	SDH4	REMARKS
27	4JY-11354-02	GASKET	1	1	1	1	
28	98907-05016	SCREW, BIND	4	4	4	4	
29	90508-161B3	SPRING, TORSION	2	2	2	2	
30	90387-08785	COLLAR	2	2	2	2	
31	4JY-11991-01	HOUSING 1	1	1	1	1	
32	4JY-11993-01	GASKET	1	1	1	1	
33	97007-05016	BOLT	4	4	4	4	
34	92907-05600	WASHER, PLATE	4	4	4	4	
35	4JY-11995-00	SEAL, HOUSING	1	1	1	1	

B3

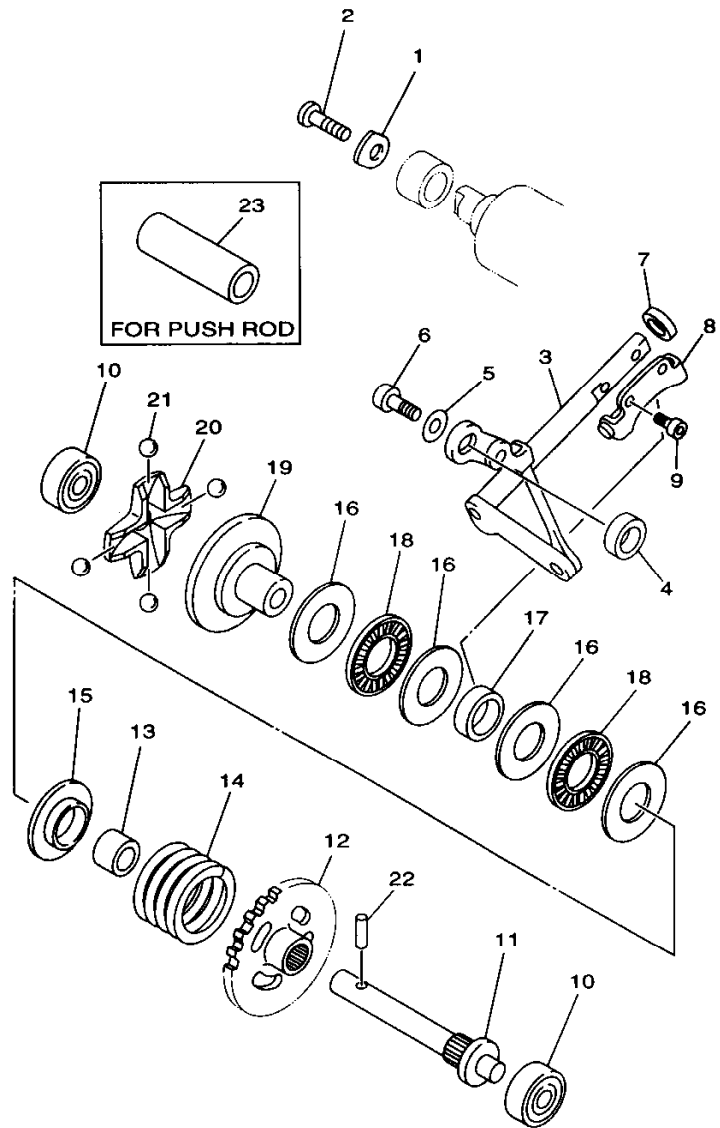

FIG. 2 GOVERNOR

REF. NO.	PART NO.	DESCRIPTION	SDH1	SDH2	SDH3	SDH4	REMARKS
1	4JY-11915-01	PLATE, THRUST 1	1	1	1	1	
2	98507-05012	SCREW, PAN HEAD	1	1	1	1	
3	4SS-11990-00	PUSH ROD ASSY	1	1	1	1	
4	90387-085E1	COLLAR	1	1	1	1	
5	90201-057H5	WASHER, PLATE	1	1	1	1	
6	97007-05012	BOLT	1	1	1	1	
7	93104-08040	OIL SEAL	1	1	1	1	
8	3JE-11922-01	FORK, GOVERNOR	1	1	1	1	
9	91317-04006	BOLT	2	2	2	2	
10	93300-60801	BEARING (B0060)	2	2	2	2	KOYO
11	5X4-11921-02	SHAFT, GOVERNOR	1	1	1	1	
12	24X-11953-01	GEAR, GOVERNOR	1	1	1	1	
13	90560-08213	SPACER	1	1	1	1	
14	90501-30742	SPRING, COMPRESSION	1	1	1	1	
15	5X4-11952-00	PLATE	1	1	1	1	
16	90201-151A7	WASHER, PLATE (T=1.0)	4	4	4	4	
17	90387-152F2	COLLAR	1	1	1	1	
18	93340-21505	BEARING	2	2	2	2	
19	5X5-11912-01	RETAINER, WEIGHT	1	1	1	1	
20	5X5-11911-01	RETAINER	1	1	1	1	
21	93521-64032	BALL	4	4	4	4	
22	93603-14240	PIN, DOWEL	1	1	1	1	
23	90387-107T9	COLLAR	1	1	1	1	AP

FWD
5DH1100-8020

B4

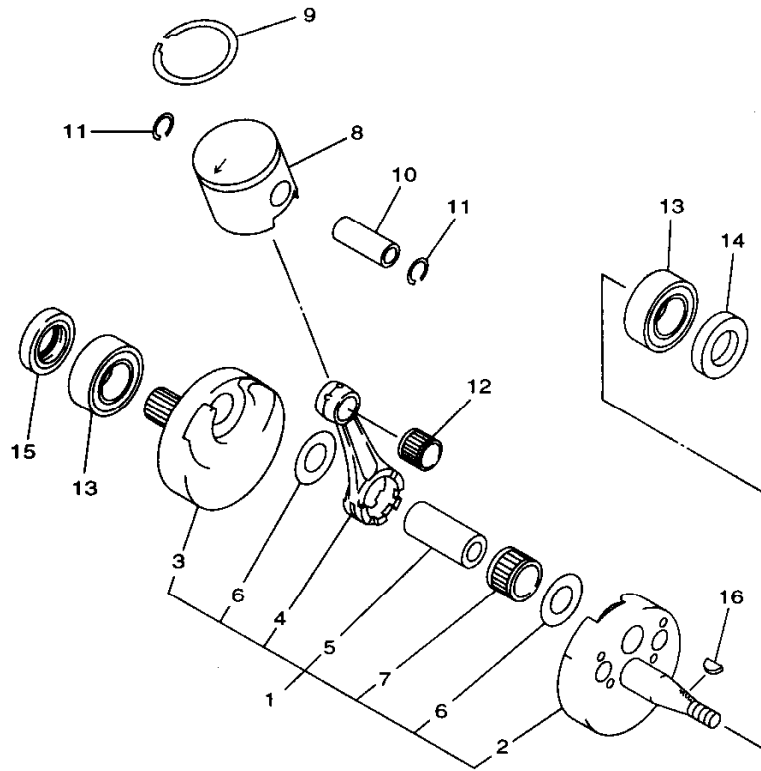

FIG. 3 CRANKSHAFT. PISTON

REF. NO.	PART NO.	DESCRIPTION	5DH1	5DH2	5DH3	5DH4	REMARKS
1	5DH-11400-00	CRANKSHAFT ASSY	1	1	1	1	
2	4SS-11410-10	.CRANKSHAFT	1	1	1	1	
3	4SS-11420-00	.CRANKSHAFT	1	1	1	1	
4	4PE-11651-02	.ROD, CONNECTING	1	1	1	1	
5	3JD-11681-02	.PIN, CRANK 1	1	1	1	1	
6	90209-22071	.WASHER	2	2	2	2	
7	93310-522P7	.BEARING	1	1	1	1	
8	4XM-11631-10-A0	PISTON (STD)	1	1	1	1	
	4XM-11631-10-B0	PISTON (STD)	1	1	1	1	
	4XM-11631-10-C0	PISTON (STD)	1	1	1	1	
	4XM-11631-10-D0	PISTON (STD)	1	1	1	1	
9	4JY-11611-00	RING, PISTON	1	1	1	1	
10	4XM-11633-10	PIN, PISTON	1	1	1	1	
11	93450-16068	CIRCLIP	2	2	2	2	
12	93310-315S4	BEARING	1	1	1	1	
13	93306-37204	BEARING (63/22SH2-9TC4)	2	2	2	2	KOYO
14	93102-22363	OIL SEAL	1	1	1	1	
15	93103-32183	OIL SEAL	1	1	1	1	
16	90280-03045	KEY, WOODRUFF	1	1	1	1	

4SS1100-6030

B5

FIG. 4 WATER PUMP

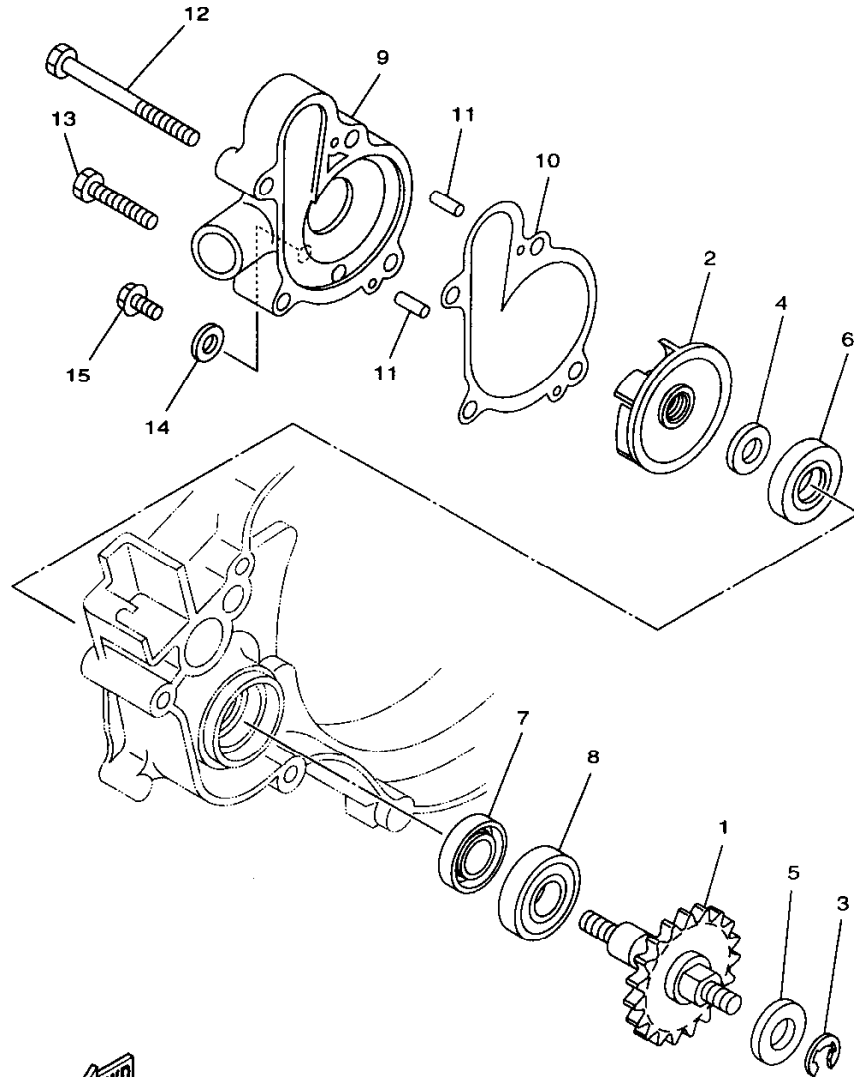

REF. NO.	PART NO.	DESCRIPTION	5DH1	5DH2	5DH3	5DH4	REMARKS
1	5DH-12459-00	GEAR, IMPELLER SHAFT	1	1	1	1	
2	5DH-12451-00	IMPELLER, WATER PUMP	1	1	1	1	
3	99001-06600	CIRCLIP	1	1	1	1	
4	90201-083P5	WASHER, PLATE	1	1	1	1	
5	90201-08784	WASHER, PLATE	1	1	1	1	
6	93109-11073	OIL SEAL	1	1	1	1	
7	93102-12106	OIL SEAL (SD 12-22-5 HS)	1	1	1	1	
8	93306-00105	BEARING (B6001)	1	1	1	1	
9	4JY-12422-00	COVER, HOUSING	1	1	1	1	
10	4JY-12428-00	GASKET, HOUSING COVER 2	1	1	1	1	
11	93604-10011	PIN, DOWEL	2	2	2	2	
12	95027-06065	BOLT, FLANGE	2	2	2	2	
13	95027-06030	BOLT, FLANGE	2	2	2	2	
14	90430-06014	GASKET	1	1	1	1	
15	95027-06010	BOLT, FLANGE	1	1	1	1	

5DH1100-8040

B6

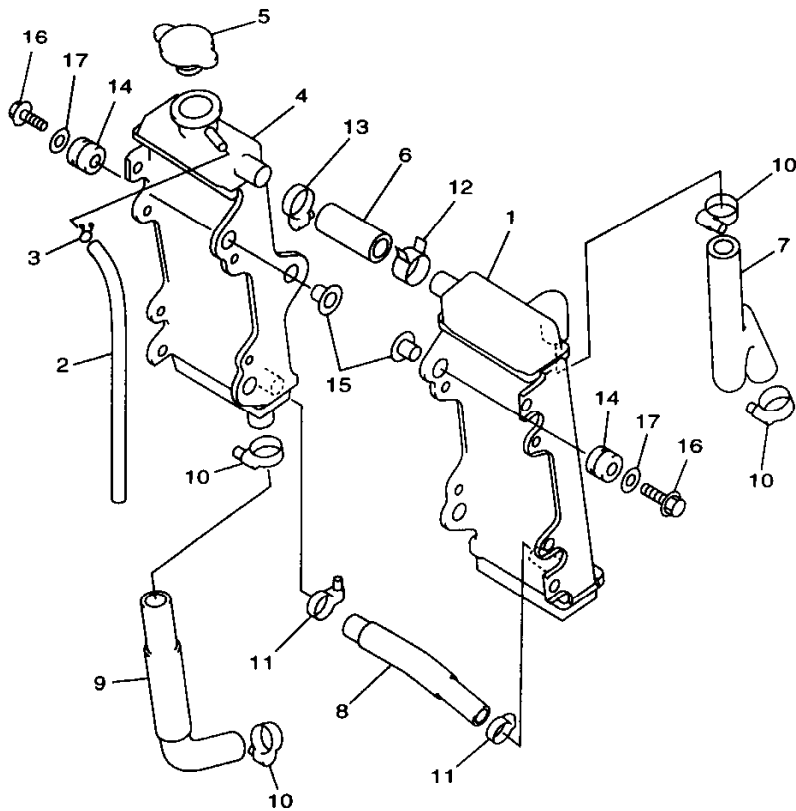

FIG. 5 RADIATOR. HOSE

REF. NO.	PART NO.	DESCRIPTION	5DH1	5DH2	5DH3	5DH4	REMARKS
1	4SS-1240A-00	RADIATOR ASSY	1	1	1	1	
2	91A20-05065	TUBE, FLEXIBLE VINYL	1	1	1	1	
3	90467-09006	CLIP	1	1	1	1	
4	4SS-12461-00	RADIATOR ASSY	1	1	1	1	
5	22W-12462-00	CAP, RADIATOR	1	1	1	1	
6	4SS-12481-00	PIPE 1	1	1	1	1	
7	4SS-12482-00	PIPE 2	1	1	1	1	
8	4SS-12483-00	PIPE 3	1	1	1	1	
9	4SS-12484-00	PIPE 4	1	1	1	1	
10	90450-28014	HOSE CLAMP ASSY	4	4	4	4	
11	90450-22017	HOSE CLAMP ASSY	2	2	2	2	
12	90467-21068	CLIP	1	1	1	1	
13	90450-25037	HOSE CLAMP ASSY	1	1	1	1	
14	90480-15528	GROMMET	6	6	6	6	
15	90387-0700G	COLLAR	6	6	6	6	
16	95027-06030	BOLT, FLANGE	6	6	6	6	
17	90201-06071	WASHER, PLATE	6	6	6	6	



4SS1100-6050

B7

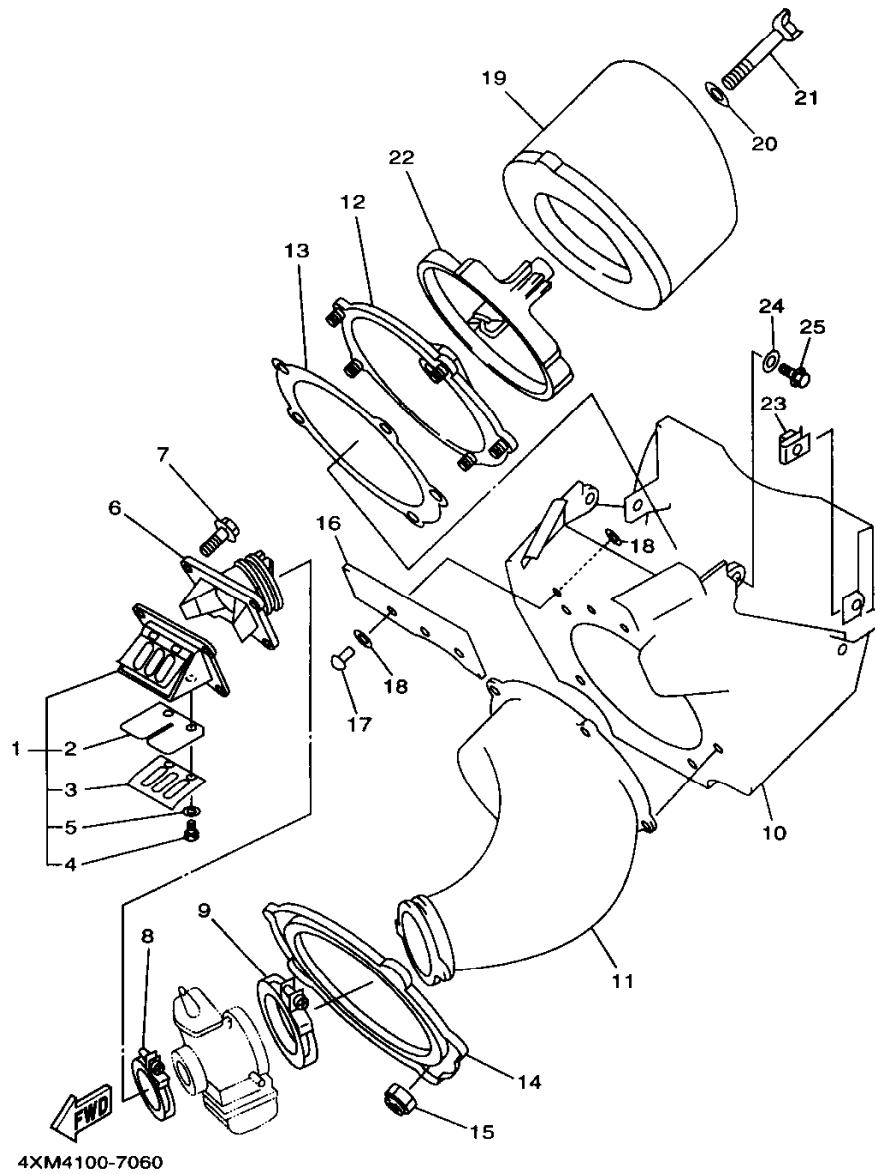

4XM4100-7060

FIG. 6 INTAKE

REF. NO.	PART NO.	DESCRIPTION	SDH1	SDH2	SDH3	SDH4	REMARKS
1	4SS-13610-00	REED VALVE ASSY	1	1	1	1	
2	4SS-13613-00	.REED, VALVE	2	2	2	2	
3	4JY-13616-00	.STOPPER, REED VALVE	2	2	2	2	
4	98507-03008	.SCREW, PAN HEAD	4	4	4	4	
5	92907-03100	.WASHER	4	4	4	4	
6	4PE-13565-00	JOINT, CARBURETOR	1	1	1	1	
7	95027-06020	BOLT, FLANGE	4	4	4	4	
8	90450-51070	HOSE CLAMP ASSY	1	1	1	1	
9	90450-70072	HOSE CLAMP ASSY	1	1	1	1	
10	4SS-14401-02	AIR CLEANER CASE ASSY	1	1	1	1	
11	4SS-14453-00	JOINT, AIR CLEANER 1	1	1	1	1	
12	3JD-14459-01	HOLDER, GUIDE	1	1	1	1	
13	3JD-14462-00	SEAL	1	1	1	1	
14	3JD-14477-00	PLATE	1	1	1	1	
15	95607-05100	NUT, U	5	5	5	5	
16	4SS-14417-00	COVER 1	1	1	1	1	
17	90267-32070	RIVET, BLIND	3	3	3	3	
18	90201-03313	WASHER, PLATE	6	6	6	6	
19	4XM-14451-00	ELEMENT, AIR CLEANER	1	1	1	1	
20	90209-06096	WASHER	1	1	1	1	
21	90122-06035	BOLT, WING	1	1	1	1	
22	3JD-14458-01	GUIDE	1	1	1	1	
23	90183-06023	NUT, SPRING	4	4	4	4	
24	90201-061A5	WASHER, PLATE	2	2	2	2	
25	90105-06553	BOLT, WASHER BASED	2	2	2	2	

B8

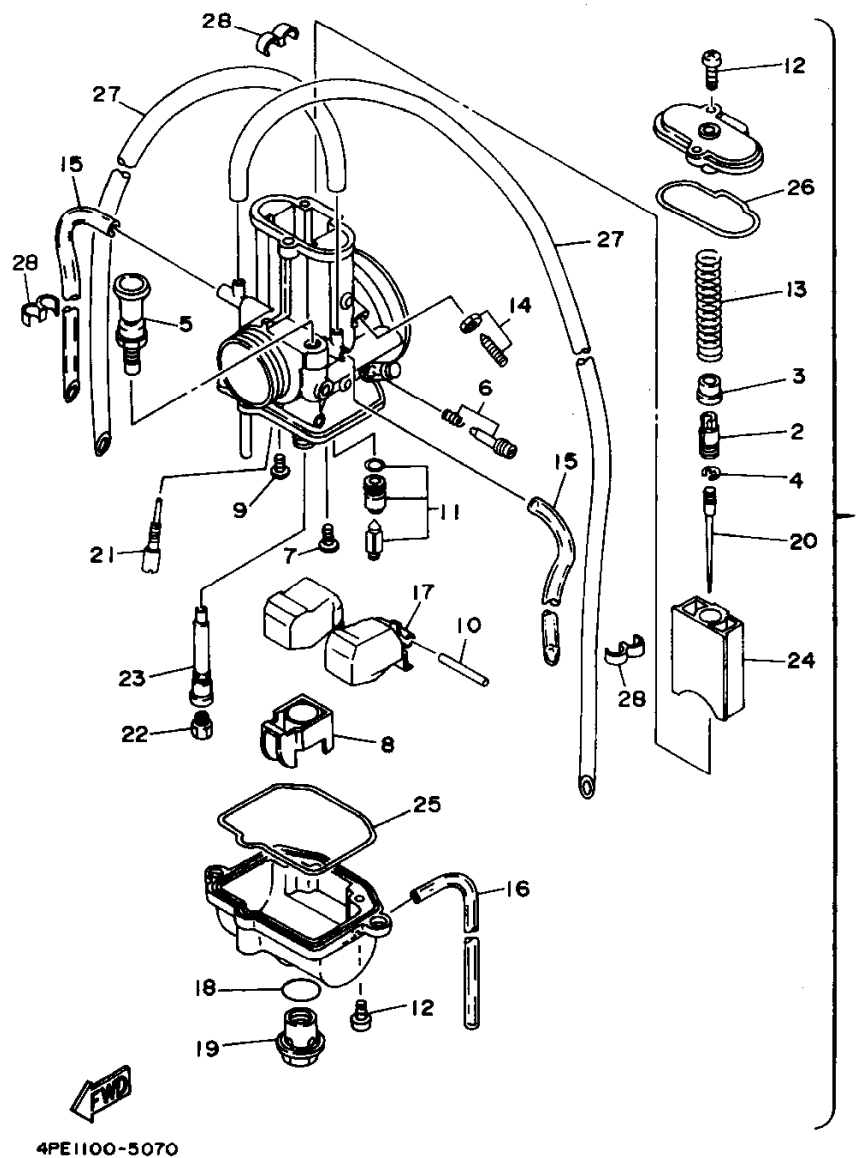
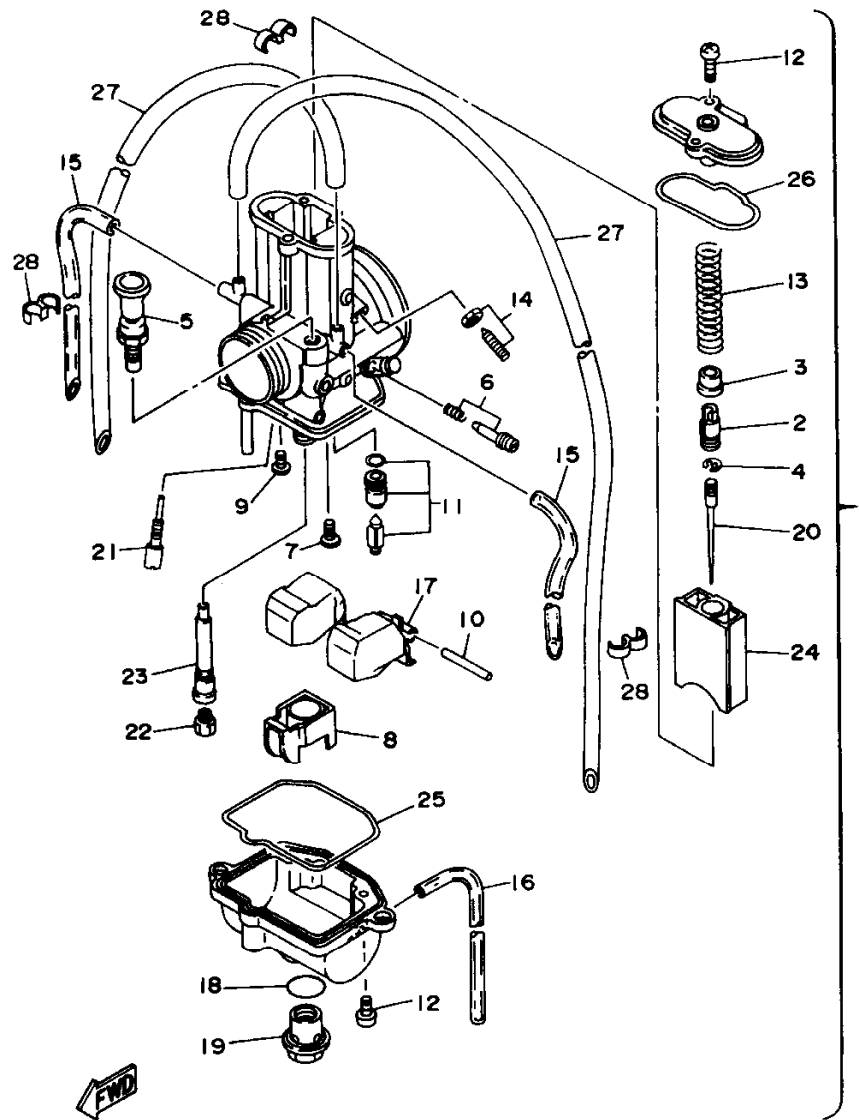

FIG. 7 CARBURETOR

REF. NO.	PART NO.	DESCRIPTION	SDH1	SDH2	SDH3	SDH4	REMARKS
1	5DH-14101-10	CARBURETOR ASSY 1	1	1	1	1	
2	4PE-14261-01	.HOLDER	1	1	1	1	
3	4PE-14194-00	.RING	1	1	1	1	
4	256-14919-00	.CLIP	1	1	1	1	
5	3JE-14171-00	.PLUNGER, STARTER	1	1	1	1	
6	3JD-14104-00	.AIR SCREW SET	1	1	1	1	
7	1FN-14565-00	.SCREW	1	1	1	1	
8	4PE-14243-00	.PLATE	1	1	1	1	
9	98507-04008	.SCREW, PAN HEAD	1	1	1	1	
10	353-14186-00	.PIN, FLOAT	1	1	1	1	
11	4PE-14107-38	.NEEDLE VALVE SET	1	1	1	1	
12	98507-04012	.SCREW, PAN HEAD	3	3	3	3	
13	4PE-14131-00	.SPRING, THROTTLE VALVE	1	1	1	1	
14	4PE-14103-00	.THROTTLE SCREW SET	1	1	1	1	
15	2HH-14197-00	.PIPE	2	2	2	2	
16	3X3-14197-00	.PIPE	1	1	1	1	
17	4PE-14185-00	.FLOAT	1	1	1	1	
18	3JE-14561-00	.O-RING	1	1	1	1	
19	3XK-14115-00	.PLUG, SCREW	1	1	1	1	
20	5A0-14116-F2	.NEEDLE (6BEF16-69)	1	1	1	1	STD
	5A0-14116-F0	.NEEDLE (6BEF16-67)	1	1	1	1	AP
	5A0-14116-F1	.NEEDLE (6BEF16-68)	1	1	1	1	AP
	5A0-14116-F3	.NEEDLE (6BEF16-70)	1	1	1	1	AP
	5A0-14116-F4	.NEEDLE (6BEF16-71)	1	1	1	1	AP
21	4KM-14142-45	.JET, PILOT (# 45)	1	1	1	1	STD
	4KM-14142-40	.JET, PILOT (# 40)	1	1	1	1	AP
	4KM-14142-50	.JET, PILOT (# 50)	1	1	1	1	AP

B9

FIG. 7 CARBURETOR



4PE1100-5070

REF. NO.	PART NO.	DESCRIPTION	5DH1	5DH2	5DH3	5DH4	REMARKS
21	4KM-14142-55	.JET, PILOT (# 55)	1	1	1	1	AP
	4KM-14142-60	.JET, PILOT (# 60)	1	1	1	1	AP
	4KM-14142-65	.JET, PILOT (# 65)	1	1	1	1	AP
22	137-14143-70	.JET, MAIN (#350)	1	1	1	1	STD
	137-14143-66	.JET, MAIN (#330)	1	1	1	1	AP
	137-14143-68	.JET, MAIN (#340)	1	1	1	1	AP
	137-14143-72	.JET, MAIN (#360)	1	1	1	1	AP
	137-14143-74	.JET, MAIN (#370)	1	1	1	1	AP
23	3TC-14141-S9	.NOZZLE, MAIN (S-9)	1	1	1	1	STD
	3TC-14141-S5	.NOZZLE, MAIN (S-5)	1	1	1	1	AP
	3TC-14141-S6	.NOZZLE, MAIN (S-6)	1	1	1	1	AP
	3TC-14141-S7	.NOZZLE, MAIN (S-7)	1	1	1	1	AP
	3TC-14141-S8	.NOZZLE, MAIN (S-8)	1	1	1	1	AP
	3TC-14141-T0	.NOZZLE, MAIN (T-0)	1	1	1	1	AP
24	4SS-14112-50	.VALVE, THROTTLE (C.A 5.0)	1	1	1	1	STD
	4SS-14112-45	.VALVE, THROTTLE (C.A 4.5)	1	1	1	1	AP
	4SS-14112-55	.VALVE, THROTTLE (C.A 5.5)	1	1	1	1	AP
25	4PE-1416A-00	.O-RING	1	1	1	1	
26	4PE-14147-00	.O-RING	1	1	1	1	
27	4PE-14197-00	.PIPE	2	2	2	2	
28	87M-14137-00	.CLIP	3	3	3	3	

B10

FIG. 8 EXHAUST

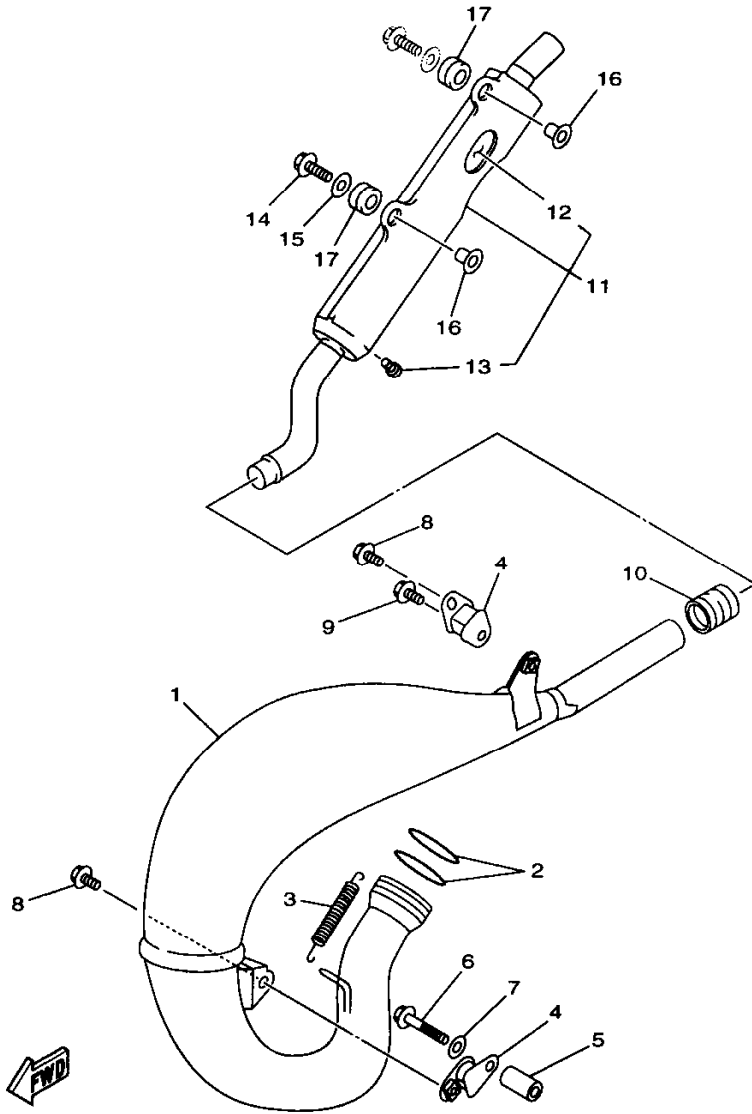

5DH1100-8080

REF. NO.	PART NO.	DESCRIPTION	5DH1	5DH2	5DH3	5DH4	REMARKS
1	4XM-14610-00	EXHAUST PIPE ASSY 1	1	1	1	1	
2	93210-42728	O-RING	2	2	2	2	
3	90507-20052	SPRING, TENSION	2	2	2	2	
4	565-14771-00	STAY, MUFFLER 1	2	2	2	2	
5	90387-062W7	COLLAR	1	1	1	1	
6	95027-06045	BOLT, FLANGE	1	1	1	1	
7	90201-06060	WASHER, PLATE	1	1	1	1	
8	95027-06012	BOLT, FLANGE	2	2	2	2	
9	90119-06185	BOLT, WITH WASHER	1	1	1	1	
10	4JY-14615-00	JOINT, EXHAUST 1	1	1	1	1	
11	5DH-14753-00	SILENCER, EXHAUST	1	1	1	1	
12	4SR-1469A-00	.FIBER	1	1	1	1	
13	92017-06010	.BOLT, BUTTON HEAD	2	2	2	2	
14	95027-06025	BOLT, FLANGE	1	1	1	1	
15	90201-06071	WASHER, PLATE	1	1	1	1	
16	90387-063G3	COLLAR	2	2	2	2	
17	90480-16561	GROMMET	2	2	2	2	

B11

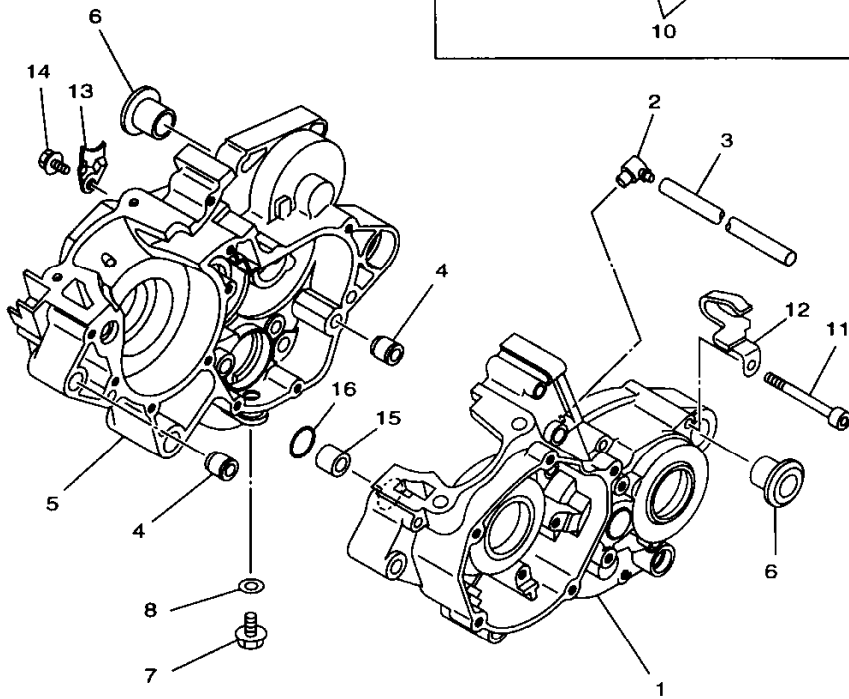
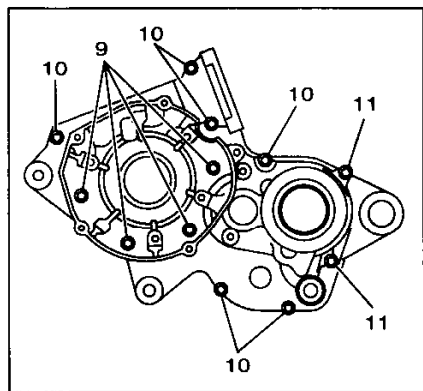

5DH1100-8090

FIG. 9 CRANKCASE

REF. NO.	PART NO.	DESCRIPTION	SDH1	SDH2	SDH3	SDH4	REMARKS
1	5DH-15111-00	CRANKCASE 1	1	1	1	1	
2	353-13115-01	CONNECTOR, SUCTION PIPE	1	1	1	1	
3	90445-08605	HOSE	1	1	1	1	
4	93612-16254	PIN, DOWEL	2	2	2	2	
5	5DH-15121-00	CRANKCASE 2	1	1	1	1	
6	90387-1712Y	COLLAR	2	2	2	2	
7	90340-12059	PLUG, STRAIGHT SCREW	1	1	1	1	
8	90430-12227	GASKET	1	1	1	1	
9	91317-06045	BOLT	4	4	4	4	
10	91317-06055	BOLT	6	6	6	6	
11	91317-06070	BOLT	2	2	2	2	
12	90461-10136	CLAMP	1	1	1	1	
13	3R4-15118-00	HOLDER	1	1	1	1	
14	90105-06556	BOLT, WASHER BASED	1	1	1	1	
15	99590-17016	PIN, DOWEL	1	1	1	1	
16	93210-16314	O-RING	1	1	1	1	

B12

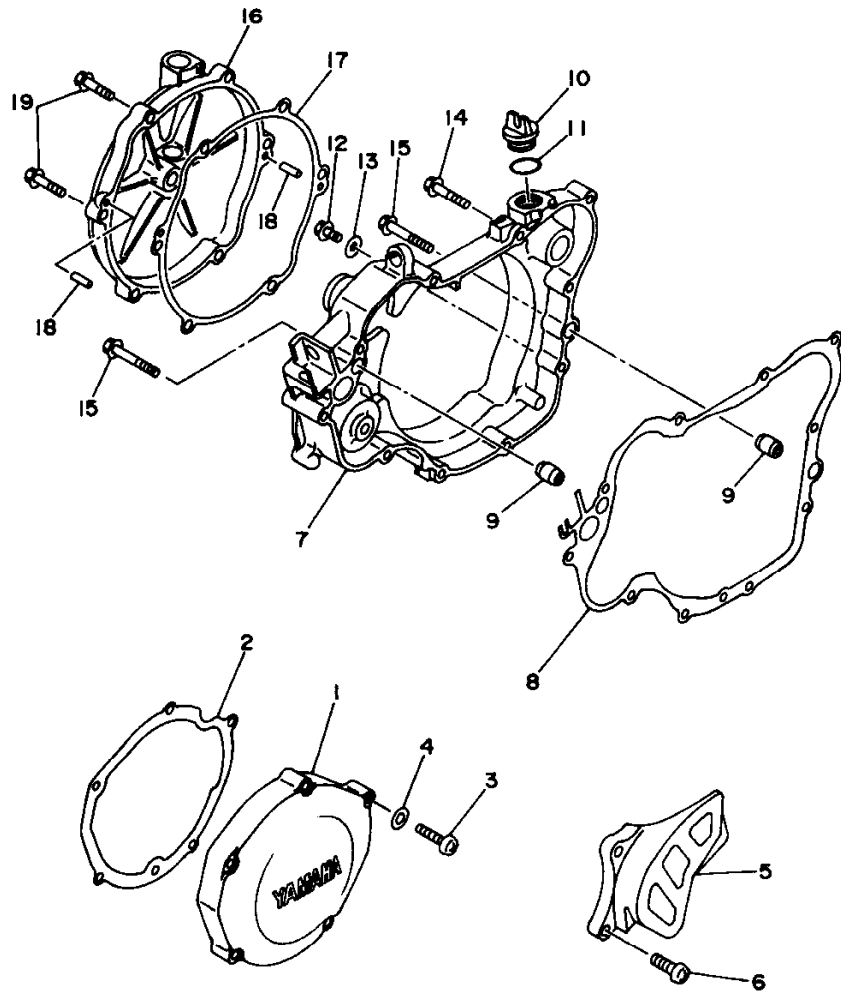

FIG. 10 CRANKCASE COVER 1

REF. NO.	PART NO.	DESCRIPTION	SDH1	SDH2	SDH3	SDH4	REMARKS
1	4JY-15411-00	COVER, CRANKCASE 1	1	1	1	1	
2	4JY-15451-01	GASKET, CRANKCASE COVER 1	1	1	1	1	
3	98507-06030	SCREW, PAN HEAD	5	5	5	5	
4	92907-06600	WASHER, PLATE	5	5	5	5	
5	4EX-15421-00	COVER, CRANKCASE 2	1	1	1	1	
6	98507-06016	SCREW, PAN HEAD	2	2	2	2	
7	4JY-15431-10	COVER, CRANKCASE 3	1	1	1	1	
8	4JY-15462-00	GASKET, CRANKCASE COVER 3	1	1	1	1	
9	99530-10114	PIN, DOWEL	2	2	2	2	
10	3Y1-15363-00	PLUG, OIL	1	1	1	1	
11	93210-19123	O-RING	1	1	1	1	
12	95027-06010	BOLT, FLANGE	1	1	1	1	
13	90430-06014	GASKET	1	1	1	1	
14	95027-06030	BOLT, FLANGE	6	6	6	6	
15	95027-06040	BOLT, FLANGE	2	2	2	2	
16	4JY-15415-00	COVER, GENERATOR	1	1	1	1	
17	4JY-15463-01	GASKET, CARBURETOR COVER 2	1	1	1	1	
18	93604-10011	PIN, DOWEL	2	2	2	2	
19	95027-06025	BOLT, FLANGE	6	6	6	6	

4JY1100-4100

B13

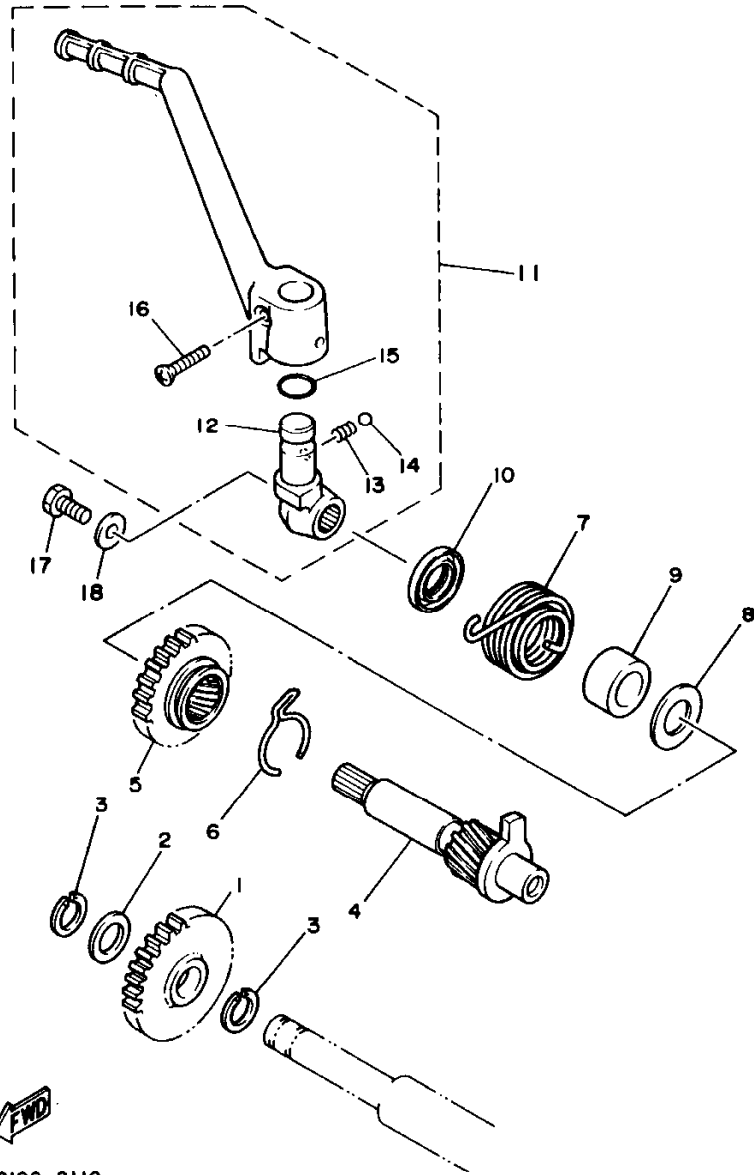
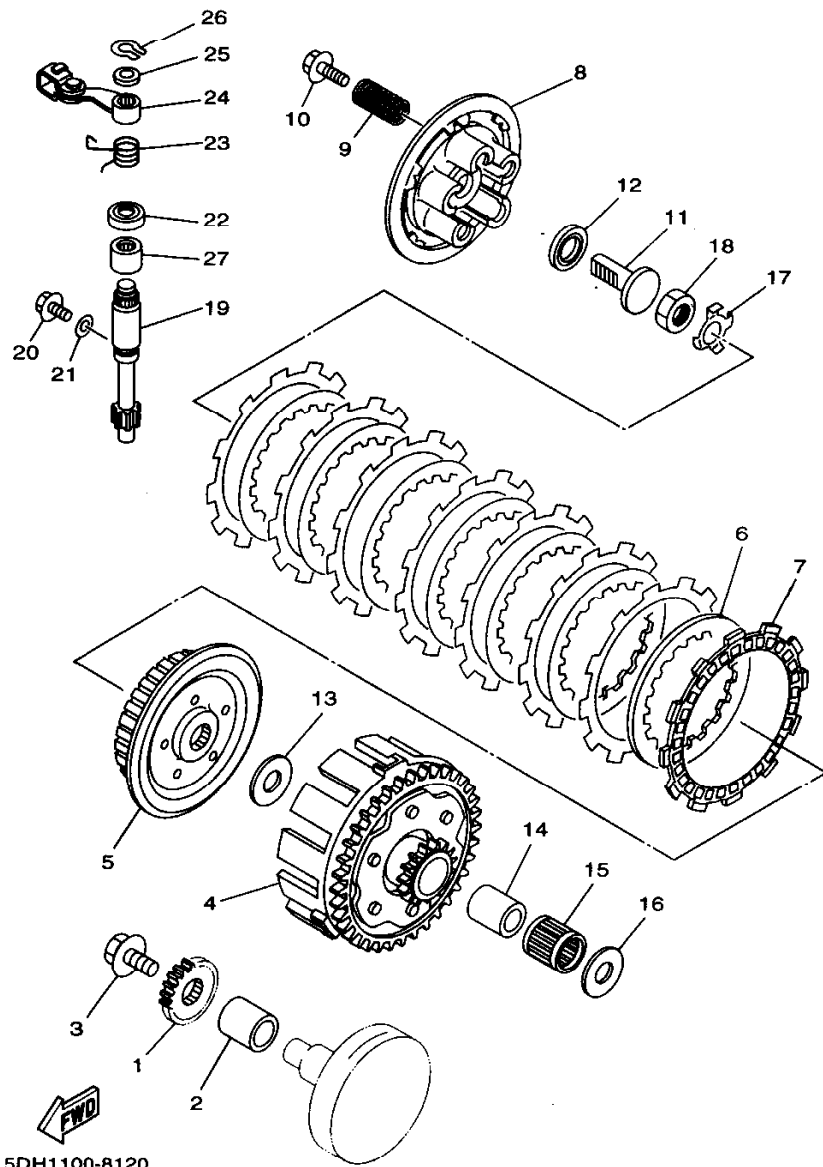

FIG. 11 STARTER

REF. NO.	PART NO.	DESCRIPTION	5DH1	5DH2	5DH3	5DH4	REMARKS
1	1LX-15651-00	GEAR, KICK IDLE	1	1	1	1	
2	90201-152H7	WASHER, PLATE	1	1	1	1	
3	93440-15012	CIRCLIP	2	2	2	2	
4	1LX-15660-03	KICK AXLE ASSY	1	1	1	1	
5	1LX-15641-00	GEAR, KICK	1	1	1	1	
6	90468-26048	CLIP	1	1	1	1	
7	90508-26450	SPRING, TORSION	1	1	1	1	
8	90201-171G4	WASHER, PLATE	1	1	1	1	
9	90560-17279	SPACER	1	1	1	1	
10	93102-17263	OIL SEAL	1	1	1	1	
11	4DB-15620-03	KICK CRANK ASSY	1	1	1	1	
12	4DB-15621-03	.BOSS, KICK CRANK	1	1	1	1	
13	90501-12081	.SPRING, COMPRESSION	1	1	1	1	
14	93507-32009	.BALL	1	1	1	1	
15	93210-15171	.O-RING	1	1	1	1	
16	90152-06010	.SCREW, COUNTERSUNK	1	1	1	1	
17	97027-06012	BOLT	1	1	1	1	
18	90201-06060	WASHER, PLATE	1	1	1	1	

FWD
4DB2100-2110

B14



5DH1100-8120

FIG. 12 CLUTCH

REF. NO.	PART NO.	DESCRIPTION	5DH1	5DH2	5DH3	5DH4	REMARKS
1	3XJ-16111-00	GEAR, PRIMARY DRIVE	1	1	1	1	
2	90387-202T9	COLLAR	1	1	1	1	
3	90105-10445	BOLT, WASHER BASED	1	1	1	1	
4	4JY-16150-02	PRIMARY DRIVEN GEAR COMP.	1	1	1	1	
5	4EX-16371-00	BOSS, CLUTCH	1	1	1	1	
6	3XJ-16324-00	PLATE, CLUTCH 1	7	7	7	7	
7	5DH-16321-00	PLATE, FRICTION	8	8	8	8	
8	4EX-16351-00	PLATE, PRESSURE 1	1	1	1	1	
9	90501-23598	SPRING, COMPRESSION	5	5	5	5	
10	90159-06016	SCREW, WITH WASHER	5	5	5	5	
11	3SB-16356-00	ROD, PUSH 1	1	1	1	1	
12	93340-21008	BEARING	1	1	1	1	
13	90201-20611	WASHER, PLATE	1	1	1	1	
14	3XJ-16181-00	SPACER 1	1	1	1	1	
15	93310-225N0	BEARING	1	1	1	1	
16	90201-20611	WASHER, PLATE	1	1	1	1	
17	90215-16289	WASHER, LOCK	1	1	1	1	
18	90170-16326	NUT	1	1	1	1	
19	4EX-16382-00	AXLE, PUSH LEVER	1	1	1	1	
20	90109-06418	BOLT	1	1	1	1	
21	90430-06014	GASKET	1	1	1	1	
22	93102-12224	OIL SEAL	1	1	1	1	
23	90508-141B4	SPRING, TORSION	1	1	1	1	
24	3JD-16340-00	PUSH LEVER ASSY	1	1	1	1	
25	90201-10119	WASHER, PLATE	1	1	1	1	
26	99009-10400	CIRCLIP	1	1	1	1	
27	93315-11206	BEARING	1	1	1	1	

B15

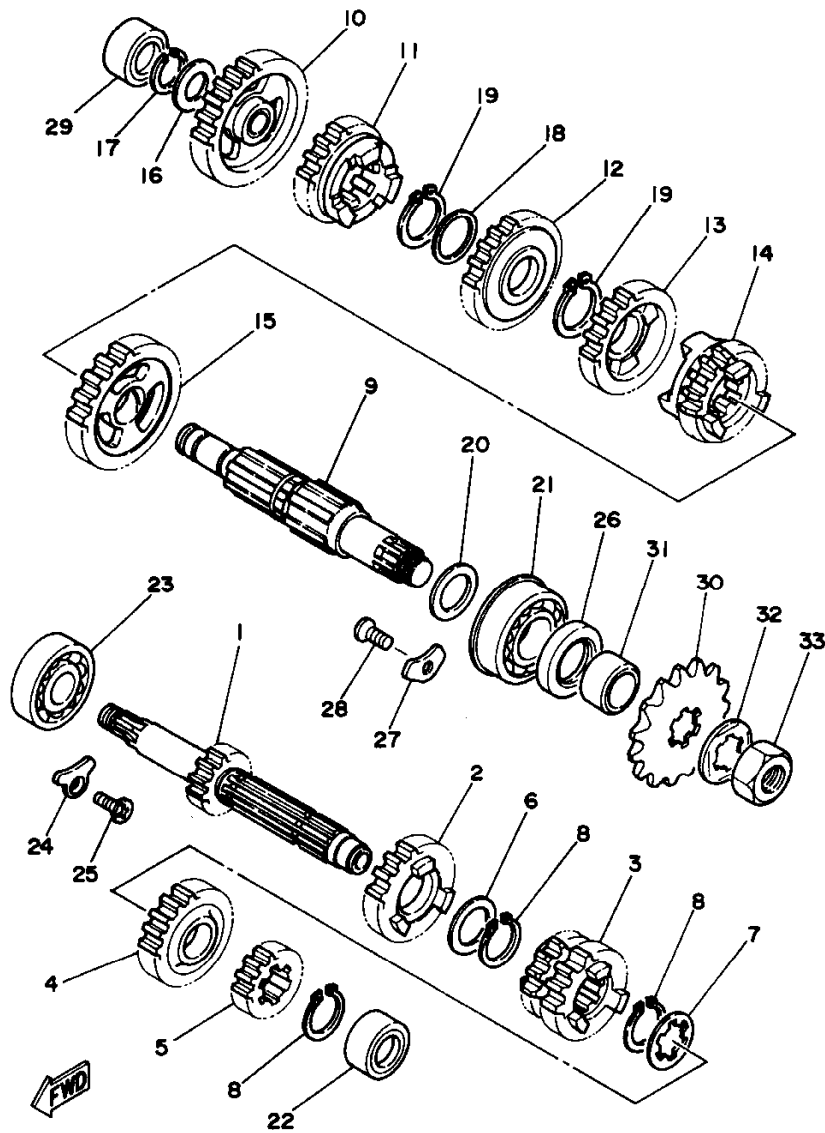

3XJ1100-1130

FIG. 13 TRANSMISSION

REF. NO.	PART NO.	DESCRIPTION	SDH1	SDH2	SDH3	SDH4	REMARKS
1	4XM-17411-00	AXLE, MAIN	1	1	1	1	
2	4EX-17151-00	GEAR, 5TH PINION	1	1	1	1	
3	4EX-17131-01	GEAR, 3RD PINION	1	1	1	1	
4	4XM-17161-00	GEAR, 6TH PINION	1	1	1	1	
5	4XM-17121-00	GEAR, 2ND PINION	1	1	1	1	
6	90201-22555	WASHER, PLATE	1	1	1	1	
7	90209-18135	WASHER	1	1	1	1	
8	93410-22039	CIRCLIP	3	3	3	3	
9	4XM-17421-00	AXLE, DRIVE	1	1	1	1	
10	4XM-17211-00	GEAR, 1ST WHEEL	1	1	1	1	
11	4EX-17251-01	GEAR, 5TH WHEEL	1	1	1	1	
12	3SR-17231-00	GEAR, 3RD WHEEL	1	1	1	1	
13	4EX-17241-00	GEAR, 4TH WHEEL	1	1	1	1	
14	4XM-17261-00	GEAR, 6TH WHEEL	1	1	1	1	
15	4XM-17221-00	GEAR, 2ND WHEEL	1	1	1	1	
16	90201-15700	WASHER, PLATE	1	1	1	1	
17	93440-15012	CIRCLIP	1	1	1	1	
18	90209-18208	WASHER	1	1	1	1	
19	93410-22039	CIRCLIP	2	2	2	2	
20	90201-20611	WASHER, PLATE	1	1	1	1	
21	93306-30411	BEARING (B6304)	1	1	1	1	
22	93311-41530	BEARING	1	1	1	1	
23	93306-20431	BEARING (B6204Z)	1	1	1	1	
24	1LX-15383-00	PLATE, BEARING COVER	1	1	1	1	
25	90151-06037	SCREW, COUNTERSUNK	1	1	1	1	
26	93102-26042	OIL SEAL	1	1	1	1	
27	4XM-15383-00	PLATE, BEARING COVER	2	2	2	2	

C2

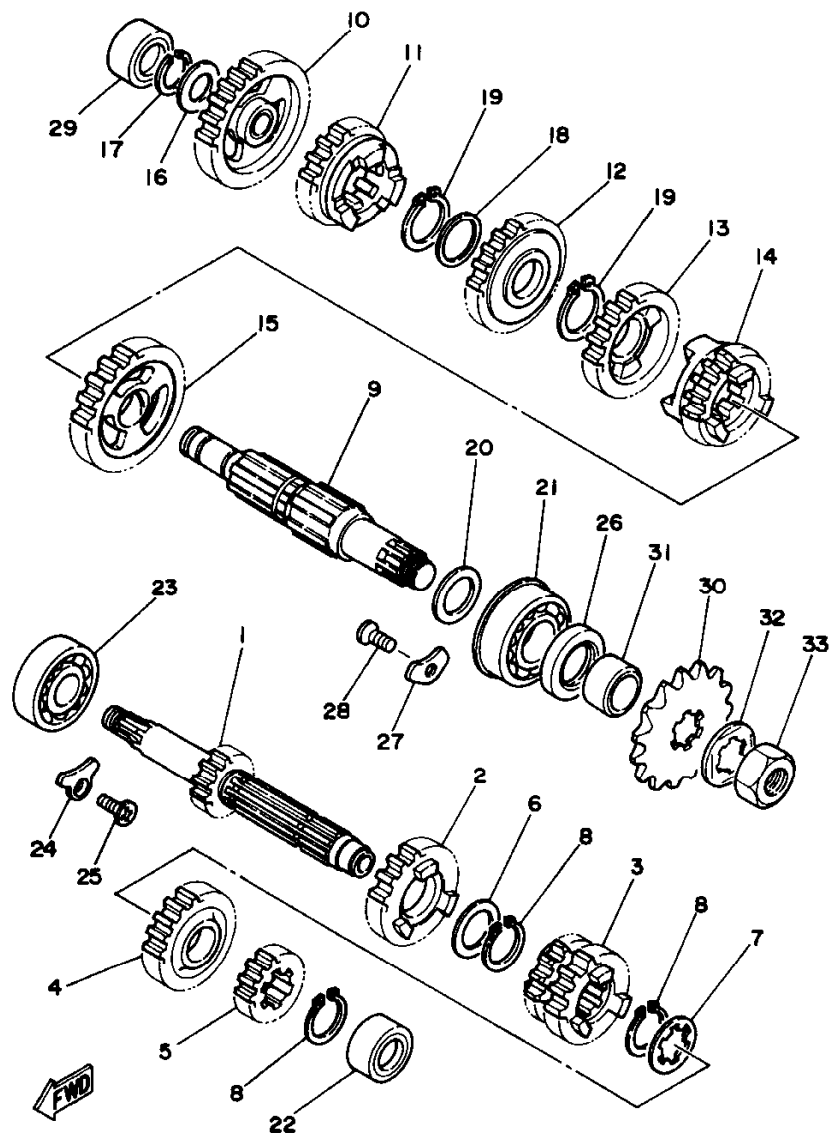

3XJ1100-1130

FIG. 13 TRANSMISSION

REF. NO.	PART NO.	DESCRIPTION	5DH1	5DH2	5DH3	5DH4	REMARKS
28	90151-06037	SCREW, COUNTERSUNK	1	1	1	1	
29	93311-31515	BEARING	1	1	1	1	
30	9383A-13031	SPROCKET,DRIVE 13T(2HG1746130)	1	1	1	1	STD
	9383A-12017	SPROCKET,DRIVE 12T(2HG1746120)	1	1	1	1	AP
	9383A-14054	SPROCKET,DRIVE 14T(2HG1746140)	1	1	1	1	AP
31	90387-202A0	COLLAR	1	1	1	1	
32	90215-20261	WASHER, LOCK	1	1	1	1	
33	90179-16226	NUT	1	1	1	1	

C3

FIG. 14 SHIFT CAM. FORK

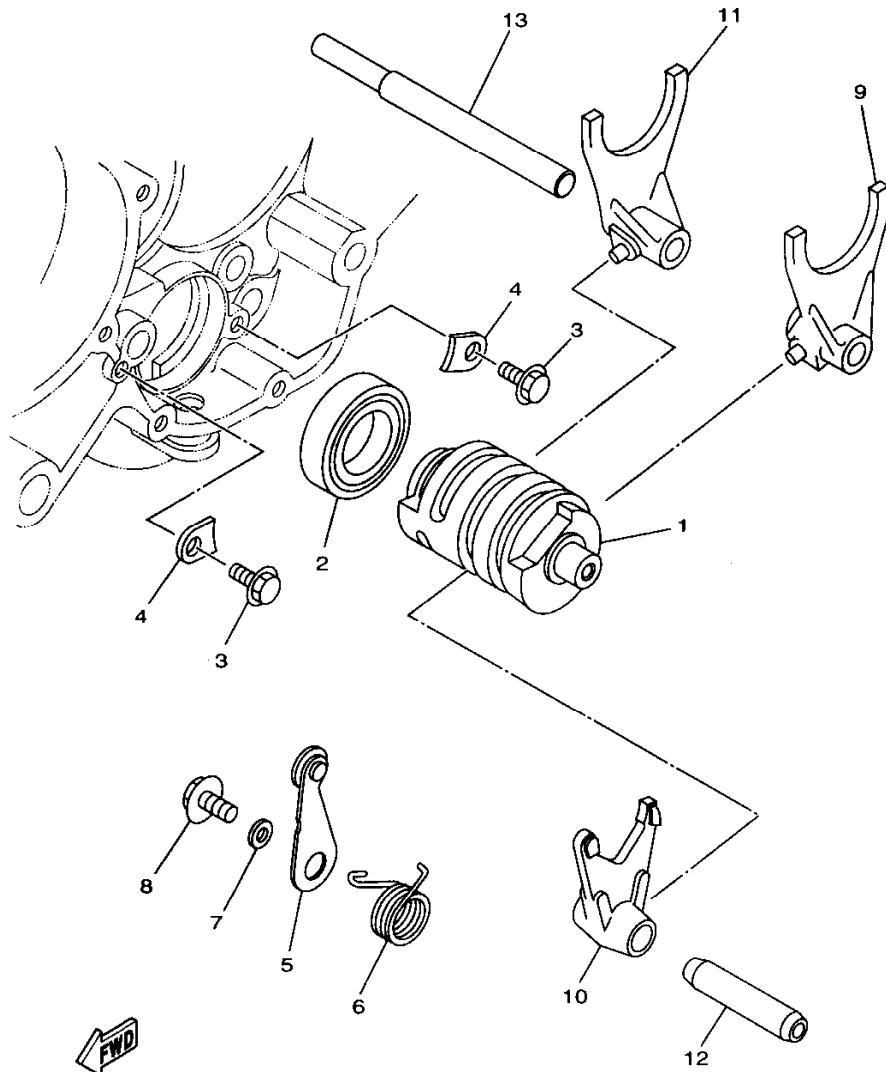

5DH1100-8140

REF. NO.	PART NO.	DESCRIPTION	5DH1	5DH2	5DH3	5DH4	REMARKS
1	5DH-18541-00	CAM, SHIFT	1	1	1	1	
2	93306-90504	BEARING	1	1	1	1	
3	90105-06553	BOLT, WASHER BASED	2	2	2	2	
4	5DH-18562-00	PLATE, STOPPER 2	2	2	2	2	
5	4JY-18140-00	STOPPER LEVER ASSY	1	1	1	1	
6	90508-261B7	SPRING, TORSION	1	1	1	1	
7	90387-063F7	COLLAR	1	1	1	1	
8	90159-06078	SCREW, WITH WASHER	1	1	1	1	
9	4SS-18511-00	FORK, SHIFT 1	1	1	1	1	
10	2VN-18512-01	FORK, SHIFT 2	1	1	1	1	
11	4SS-18513-00	FORK, SHIFT 3	1	1	1	1	
12	4EX-18531-00	BAR, SHIFT FORK GUIDE 1	1	1	1	1	
13	4EX-18535-00	BAR, SHIFT FORK GUIDE 2	1	1	1	1	

C4

FIG. 15 SHIFT SHAFT

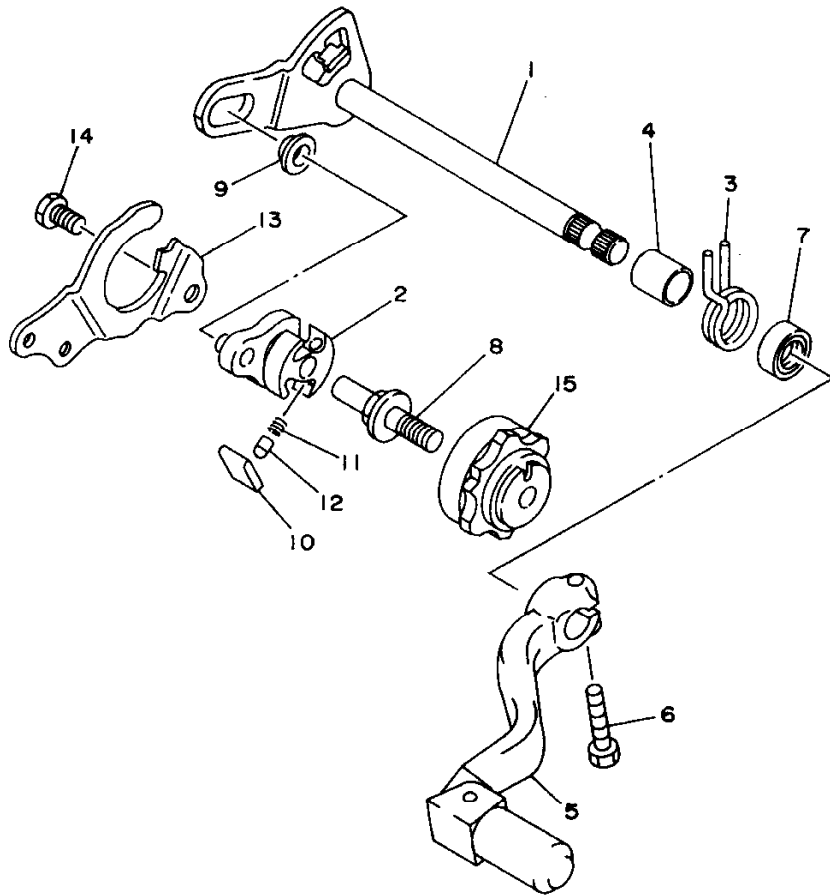

REF. NO.	PART NO.	DESCRIPTION	SDH1	SDH2	SDH3	SDH4	REMARKS
1	4SS-18101-00	SHIFT SHAFT ASSY	1	1	1	1	
2	3XJ-18122-00	LEVER, SHIFT 2	1	1	1	1	
3	90508-295A7	SPRING, TORSION	1	1	1	1	
4	90560-12280	SPACER	1	1	1	1	
5	4SS-18110-00	SHIFT PEDAL ASSY	1	1	1	1	
6	95027-06020	BOLT, FLANGE	1	1	1	1	
7	93109-12012	OIL SEAL	1	1	1	1	
8	3XJ-18173-00	PIN, SHIFT	1	1	1	1	
9	3XJ-18178-00	ROLLER, SHIFT LEVER	1	1	1	1	
10	3XJ-18182-00	PAWL, SHIFTER	2	2	2	2	
11	90501-052G5	SPRING, COMPRESSION	2	2	2	2	
12	3XJ-18184-00	PIN, PAWL	2	2	2	2	
13	4JY-18172-00	GUIDE, SHIFT	1	1	1	1	
14	90101-06664	BOLT	2	2	2	2	
15	4EW-18185-00	SEGMENT	1	1	1	1	



4SS1100-8150

C5

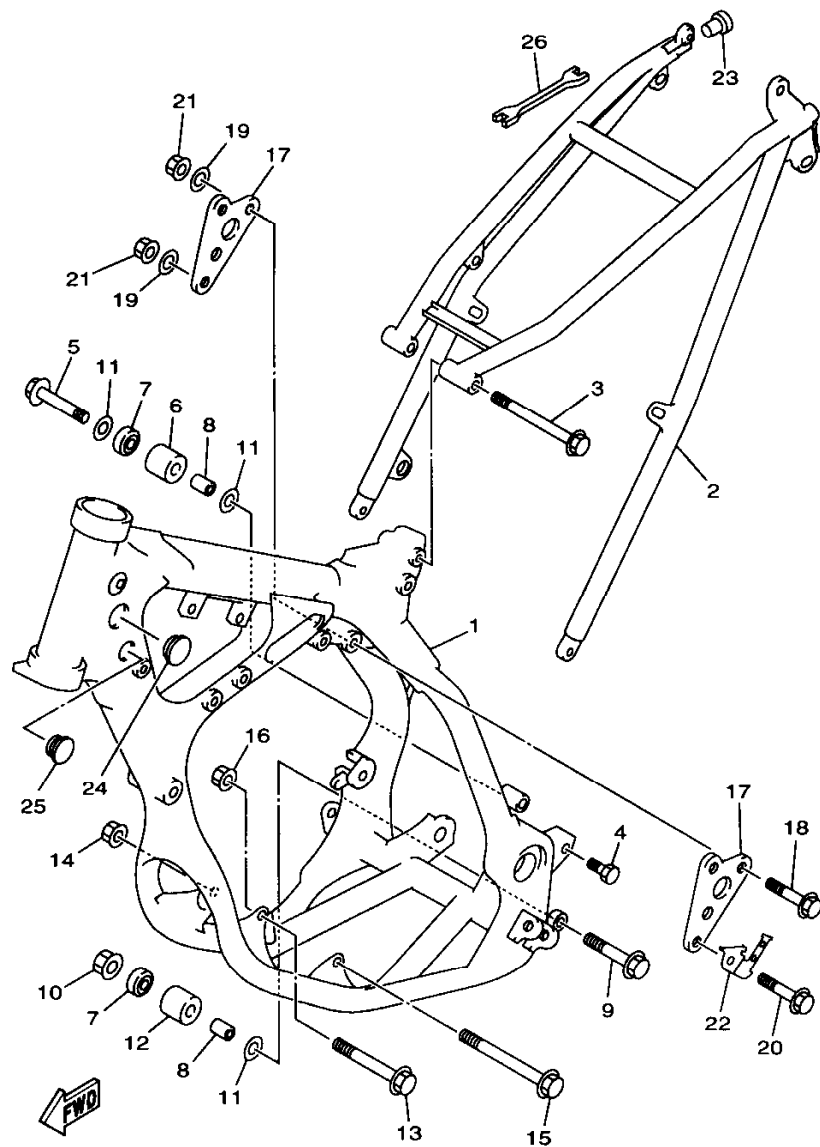

5DH1100-8160

FIG. 16 FRAME

REF. NO.	PART NO.	DESCRIPTION					REMARKS
			5DH1	5DH2	5DH3	5DH4	
1	5DH-21101-00-P0	FRONT FRAME COMP.	1	1	1	1	DPBMC
2	5DH-21190-00-P0	REAR FRAME COMP.	1	1	1	1	DPBMC
3	90105-08099	BOLT, WASHER BASED	1	1	1	1	
4	90110-08096	BOLT, HEXAGON SOCKET HEAD	2	2	2	2	
5	95027-08040	BOLT, FLANGE	1	1	1	1	
6	4EW-22178-00	TENSIONER	1	1	1	1	
7	93300-60804	BEARING	2	2	2	2	
8	90387-086N4	COLLAR	2	2	2	2	
9	95027-08065	BOLT, FLANGE	1	1	1	1	
10	95707-08500	NUT, FLANGE	1	1	1	1	
11	90201-086P8	WASHER, PLATE	3	3	3	3	
12	3JD-22178-10	TENSIONER	1	1	1	1	
13	95817-10090	BOLT, FLANGE	1	1	1	1	
14	95617-10200	NUT, SELF-LOCKING	1	1	1	1	
15	90105-10733	BOLT, WASHER BASED	1	1	1	1	
16	95617-10200	NUT, SELF-LOCKING	1	1	1	1	
17	4SS-21425-00	BRACKET, REAR UPPER 1	2	2	2	2	
18	95817-08050	BOLT, FLANGE	2	2	2	2	
19	90201-08730	WASHER, PLATE	3	3	3	3	
20	90105-08494	BOLT, WASHER BASED	1	1	1	1	
21	95617-08200	NUT, SELF-LOCKING	3	3	3	3	
22	5DH-21274-00	BRACKET, C.D.I. UNIT	1	1	1	1	
23	90338-16148	PLUG	2	2	2	2	
24	90338-30256	PLUG	2	2	2	2	
25	90338-21145	PLUG	4	4	4	4	
26	56A-28166-00	WRENCH, HEXAGON	1	1	1	1	

C6

FIG. 17 FENDER

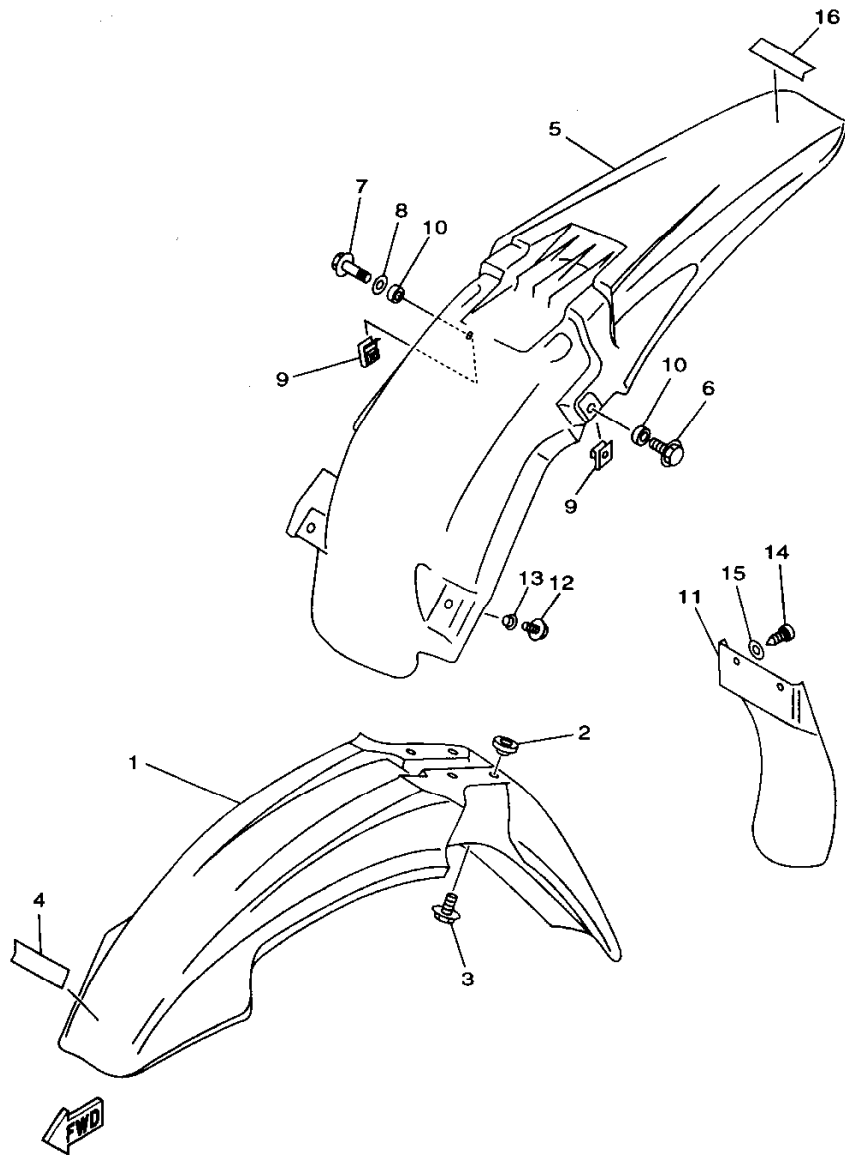

5DH1100-8170

REF. NO.	PART NO.	DESCRIPTION	5DH1	5DH2	5DH3	5DH4	REMARKS
1	4DA-21511-20	FENDER, FRONT	1	1	1	1	
2	3JD-21748-00	COLLAR	4	4	4	4	
3	90119-06096	BOLT, WITH WASHER	4	4	4	4	
4	99241-00080	EMBLEM, YAMAHA	1	1	1	1	
5	5BE-21611-10	FENDER, REAR	1	1	1	1	
6	95027-06012	BOLT, FLANGE	1	1	1	1	
7	95027-06030	BOLT, FLANGE	1	1	1	1	
8	90201-06071	WASHER, PLATE	1	1	1	1	
9	90183-06023	NUT, SPRING	2	2	2	2	
10	90387-0701A	COLLAR	2	2	2	2	
11	4ES-21642-00	GUARD, FLAP	1	1	1	1	
12	95027-06020	BOLT, FLANGE	2	2	2	2	
13	90387-0600F	COLLAR	2	2	2	2	
14	97707-60016	SCREW, TAPPING	2	2	2	2	
15	90201-06557	WASHER, PLATE	2	2	2	2	
16	99241-00080	EMBLEM, YAMAHA	1	1	1	1	

C7

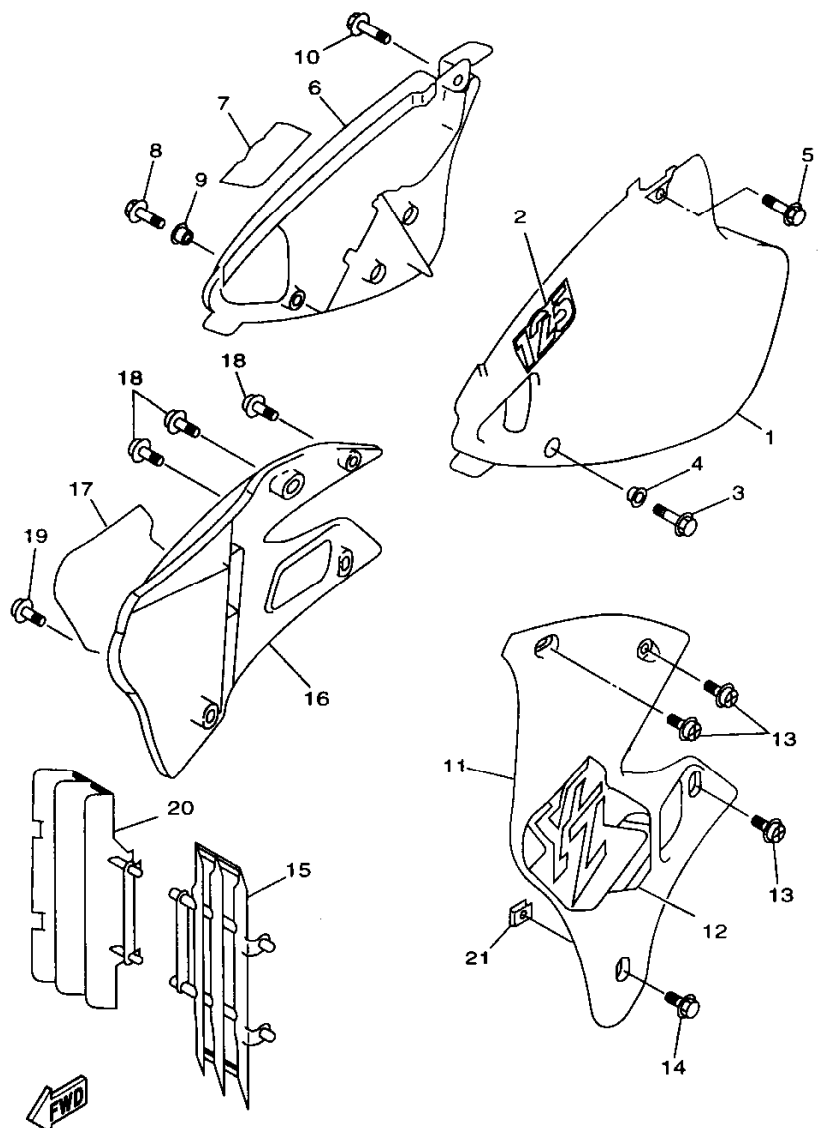

5DH1100-8180

FIG. 18 SIDE COVER

REF. NO.	PART NO.	DESCRIPTION	5DH1	5DH2	5DH3	5DH4	REMARKS
1	4SS-21711-00	COVER, SIDE 1	1	1	1	1	
2	5DH-21781-00	EMBLEM 1	1	1	1	1	
3	95827-06016	BOLT, FLANGE	1	1	1	1	
4	90387-0600F	COLLAR	1	1	1	1	
5	95827-06016	BOLT, FLANGE	1	1	1	1	
6	4SS-21721-00	COVER, SIDE 2	1	1	1	1	
7	5DH-21781-00	EMBLEM 1	1	1	1	1	
8	95827-06016	BOLT, FLANGE	1	1	1	1	
9	90387-0600F	COLLAR	1	1	1	1	
10	95827-06016	BOLT, FLANGE	1	1	1	1	
11	4SS-21731-10	COVER, SIDE 3	1	1	1	1	
12	5DH-2173E-00	GRAPHIC 1	1	1	1	1	
13	90159-06182	SCREW, WITH WASHER	3	3	3	3	
14	90159-06078	SCREW, WITH WASHER	1	1	1	1	
15	4EW-2172A-10	PANEL 1	1	1	1	1	
16	4SS-21741-10	COVER, SIDE 4	1	1	1	1	
17	5DH-2173F-00	GRAPHIC 2	1	1	1	1	
18	90159-06182	SCREW, WITH WASHER	3	3	3	3	
19	90159-06078	SCREW, WITH WASHER	1	1	1	1	
20	4EW-2172A-10	PANEL 1	1	1	1	1	
21	90183-06069	NUT, SPRING	2	2	2	2	

C8

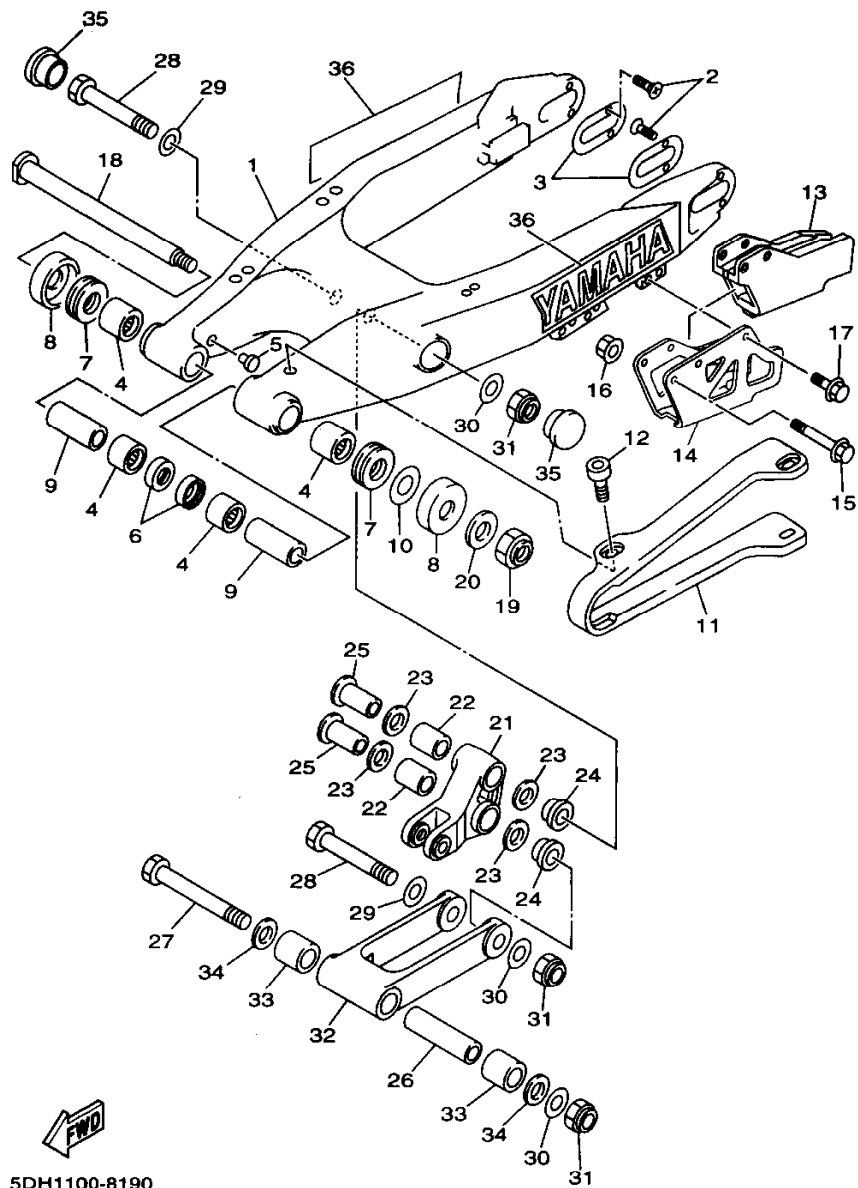
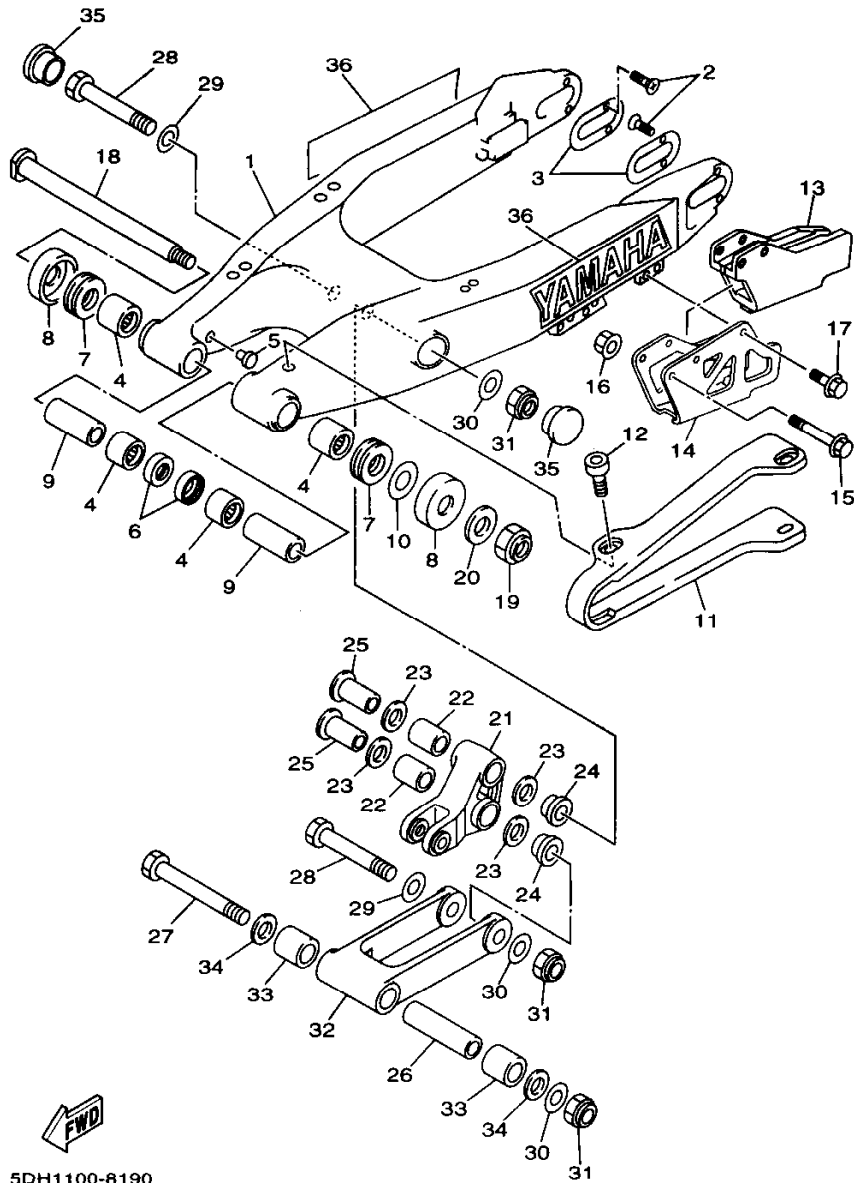

FIG. 19 REAR ARM

REF. NO.	PART NO.	DESCRIPTION	5DH1	5DH2	5DH3	5DH4	REMARKS
1	5DH-22110-00	REAR ARM COMP.	1	1	1	1	UN
2	90151-04048	SCREW, COUNTERSUNK	4	4	4	4	
3	4SS-22355-00	PATCH	2	2	2	2	
4	93317-22262	BEARING	4	4	4	4	
5	90338-16148	PLUG	2	2	2	2	
6	93106-22019	OIL SEAL (DC 22-28-8)	2	2	2	2	
7	93342-22215	BEARING	2	2	2	2	
8	5DH-22129-00	COVER, THRUST 2	2	2	2	2	
9	90387-1712R	COLLAR	2	2	2	2	
10	156-22127-00	SHIM (0.3T)	1	1	1	1	
11	4EW-22151-20	SEAL, GUARD	1	1	1	1	
12	90110-05201	BOLT, HEXAGON SOCKET HEAD	4	4	4	4	
13	4XM-22199-00	SUPPORT, CHAIN	1	1	1	1	
14	4XM-22128-00	COVER, THRUST 1	1	1	1	1	
15	95027-06050	BOLT, FLANGE	2	2	2	2	
16	90179-06568	NUT	2	2	2	2	
17	95027-06010	BOLT, FLANGE	1	1	1	1	
18	5DH-22141-00	SHAFT, PIVOT	1	1	1	1	
19	90185-16127	NUT, SELF-LOCKING	1	1	1	1	
20	90201-164H4	WASHER, PLATE	1	1	1	1	
21	5DH-2217A-00	ARM, RELAY	1	1	1	1	
22	93315-32056	BEARING	2	2	2	2	
23	93109-20029	OIL SEAL	4	4	4	4	
24	90387-164N2	COLLAR	2	2	2	2	
25	90387-164N3	COLLAR	2	2	2	2	
26	90387-167Y9	COLLAR	1	1	1	1	
27	90109-147F2	BOLT	1	1	1	1	

C9



5DH1100-8190

FIG. 19 REAR ARM

REF. NO.	PART NO.	DESCRIPTION	5DH1	5DH2	5DH3	5DH4	REMARKS
28	90109-142F4	BOLT	2	2	2	2	
29	90201-164H4	WASHER, PLATE	2	2	2	2	
30	90201-14740	WASHER, PLATE	3	3	3	3	
31	90185-14112	NUT, SELF-LOCKING	3	3	3	3	
32	5DH-2217F-00	ROD, CONNECTING 1	1	1	1	1	
33	93315-32056	BEARING	2	2	2	2	
34	93109-20029	OIL SEAL	2	2	2	2	
35	1HX-2135F-10	COVER	2	2	2	2	
36	99244-00200	EMBLEM, YAMAHA	2	2	2	2	

C10

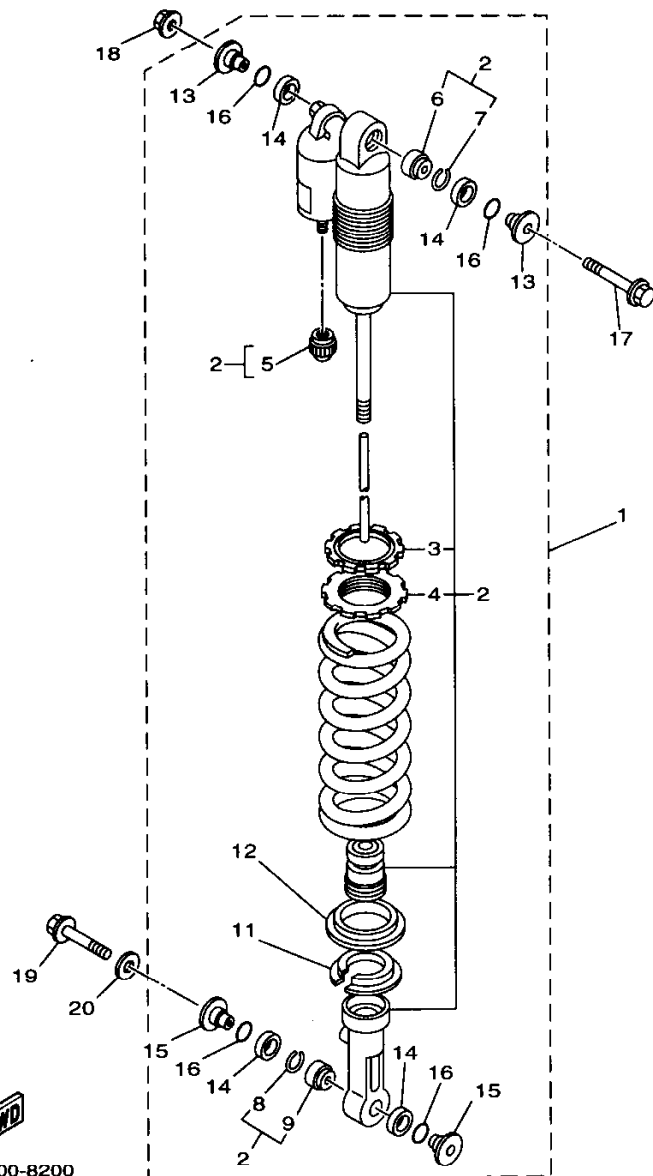

5DH1100-8200

FIG. 20 REAR SUSPENSION

REF. NO.	PART NO.	DESCRIPTION	5DH1	5DH2	5DH3	5DH4	REMARKS
1	5DH-22210-00	SHOCK ABSORBER ASSY, REAR	1				FOR USA
	5DH-22210-10	SHOCK ABSORBER ASSY, REAR	1	1		1	FOR ZAF
	5DH-22210-20	SHOCK ABSORBER ASSY, REAR			1		
	5DH-22210-30	SHOCK ABSORBER ASSY, REAR	1				FOR CAN
2	5DH-22201-00	..DAMPER SUB ASSY	1				FOR USA
	5DH-22201-10	..DAMPER SUB ASSY	1	1		1	FOR ZAF
	5DH-22201-20	..DAMPER SUB ASSY			1		
	5DH-22201-30	..DAMPER SUB ASSY	1				FOR CAN
3	3SP-22234-00	..GUIDE, SPRING 3	1	1	1	1	
4	3SP-22213-00	..SEAT, SPRING UPPER	1	1	1	1	
5	509-23184-L0	..CAP, AIR VALVE	1	1	1	1	
6	4JX-22226-00	..BUSH, SHOCK ABSORBER LOWER	1	1	1	1	
7	3Y6-23183-00	..CIRCLIP	1	1	1	1	
8	3Y6-23183-00	..CIRCLIP	1	1	1	1	
9	4JX-22226-00	..BUSH, SHOCK ABSORBER LOWER	1	1	1	1	
10	5DH-22212-10	..SPRING (K=4.6)	1	1	1	1	
11	5DH-22214-00	..GUIDE, SPRING 1	1	1	1	1	
12	5DH-22224-00	..GUIDE, SPRING 2	1	1	1	1	
13	5DH-22253-00	..COLLAR, DISTANCE	2	2	2	2	
14	3JE-22475-00	..SEAL, DUST	4	4	4	4	
15	4EW-22253-00	..COLLAR, DISTANCE	2	2	2	2	
16	4EW-22474-00	..SEAL, RING	4	4	4	4	
17	90105-10323	BOLT, WASHER BASED	1	1	1	1	
18	95617-10200	NUT, SELF-LOCKING	1	1	1	1	
19	90105-105A2	BOLT, WASHER BASED	1	1	1	1	
20	90201-112U6	WASHER, PLATE	1	1	1	1	

C11

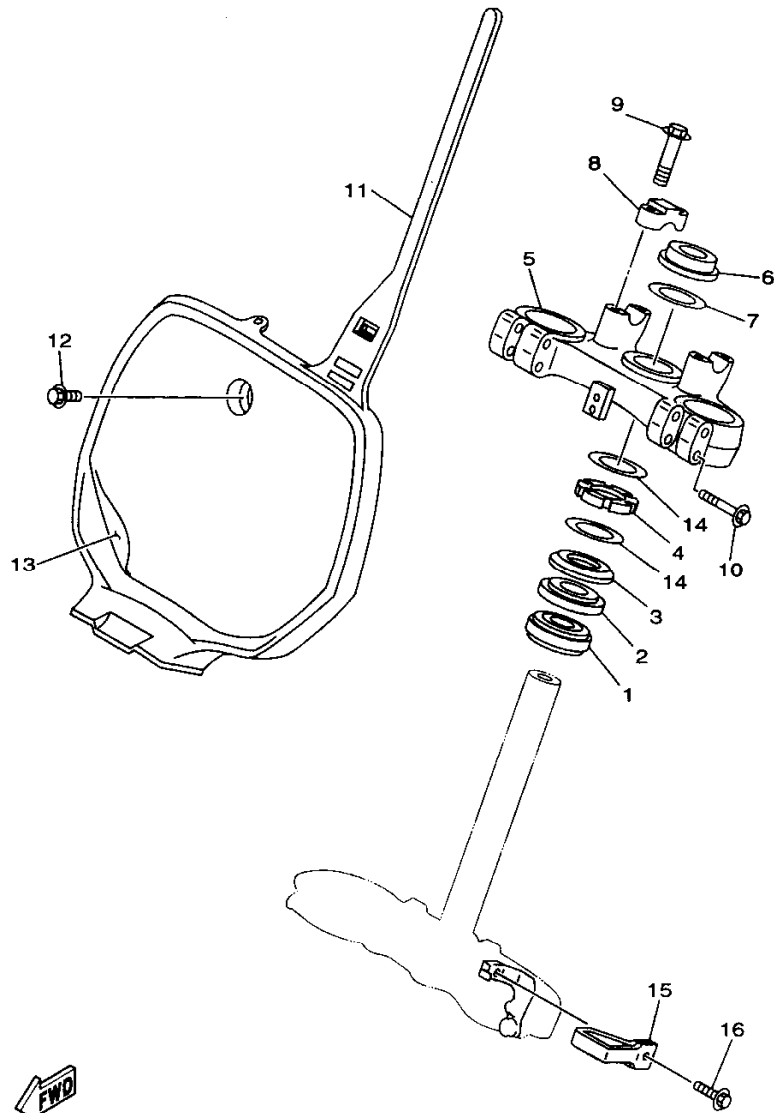

5DH1100-8210

FIG. 21 STEERING

REF. NO.	PART NO.	DESCRIPTION	5DH1	5DH2	5DH3	5DH4	REMARKS
1	93332-00081	BEARING	1	1	1	1	
2	93332-00068	BEARING	1	1	1	1	
3	4EW-23416-00	COVER, BALL RACE 2	1	1	1	1	
4	90179-28650	NUT	1	1	1	1	
5	4SS-23436-00	CROWN, HANDLE	1	1	1	1	
6	90170-24373	NUT	1	1	1	1	
7	90201-247L2	WASHER, PLATE	1	1	1	1	
8	3SP-23441-00	HOLDER, HANDLE UPPER	2	2	2	2	
9	95027-08035	BOLT, FLANGE	4	4	4	4	
10	95027-08040	BOLT, FLANGE	4	4	4	4	
11	4DA-23485-20	PLATE, NUMBER	1	1	1	1	
12	90119-06185	BOLT, WITH WASHER	1	1	1	1	
13	5DH-2339E-00	GRAPHIC 1	1	1	1	1	
14	90201-286K9	WASHER, PLATE	2	2	2	2	
15	4DA-23389-00	GUIDE, CABLE	1	1	1	1	
16	90105-05361	BOLT, WASHER BASED	1	1	1	1	

C12

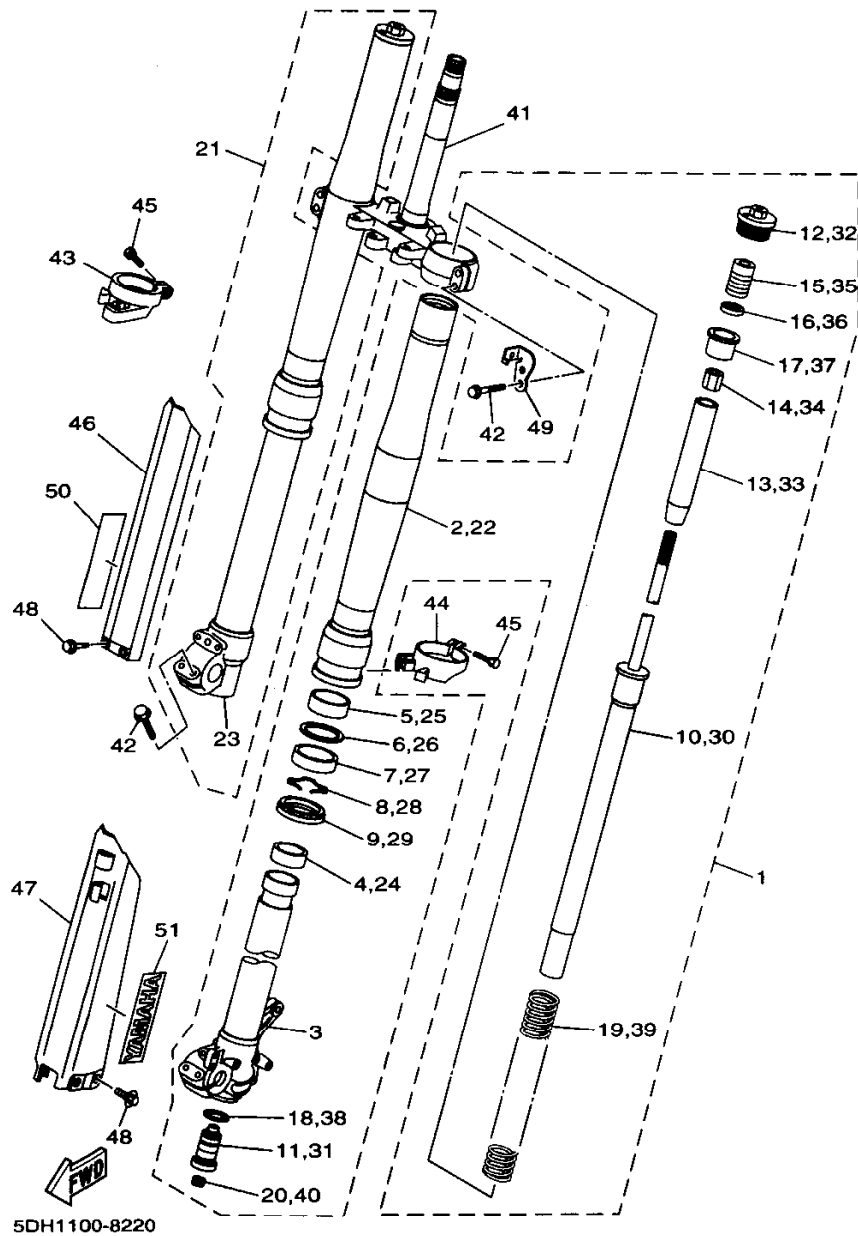
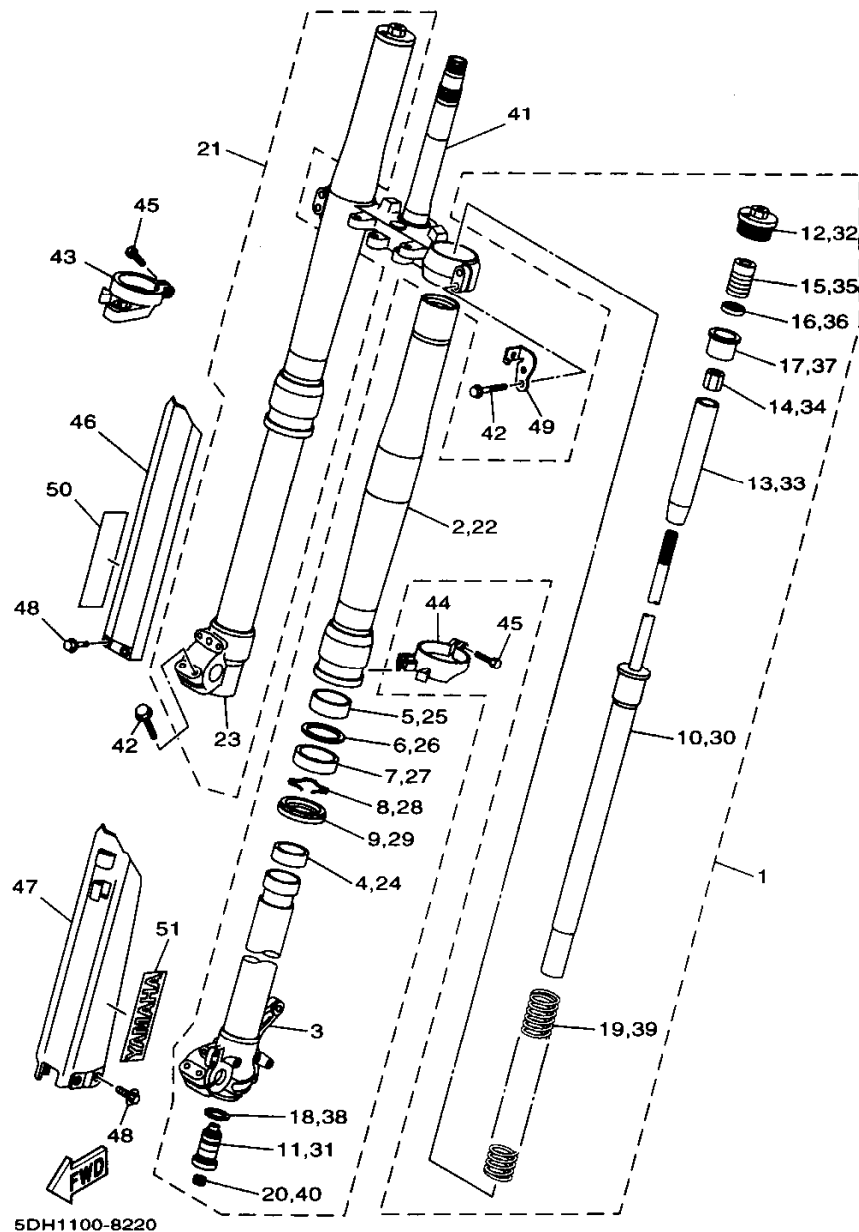

FIG. 22 FRONT FORK

REF. NO.	PART NO.	DESCRIPTION	5DH1	5DH2	5DH3	5DH4	REMARKS
1	5DH-23102-00	FRONT FORK ASSY (L.H)	1		1	1	
	5DH-23102-10	FRONT FORK ASSY (L.H)		1			
2	5DH-23136-L0	.TUBE, OUTER (RIGHT)	1	1	1	1	
3	5DH-23120-L0	.INNER TUBE COMP.2	1	1	1	1	
4	4SS-23171-L0	.PISTON, FRONT FORK	1	1	1	1	
5	4SS-23125-L0	.METAL, SLIDE 1	1	1	1	1	
6	4SS-23146-L0	.WASHER, OIL SEAL	1	1	1	1	
7	5DH-23145-L0	.OIL SEAL	1	1	1	1	
8	4SS-23153-L0	.RING, SNAP	1	1	1	1	
9	4SS-23144-L0	.SEAL, DUST	1	1	1	1	
10	5DH-23170-L0	.CYLINDER COMP., FRONT FORK	1	1	1	1	
11	5DH-2316A-L0	.VALVE COMP.	1	1	1	1	
12	5DH-23111-L0	.BOLT, CAP	1	1	1	1	
13	5DH-23142-L0	.SEAT, SPRING UPPER	1	1	1	1	
14	5DH-23393-L0	.NUT, SPECIAL	1	1	1	1	
15	5DH-23195-L0	.RUBBER	1	1	1	1	
16	5DH-23149-L0	.WASHER, SPRING UPPER	1	1	1	1	
17	5DH-23118-L0	.SPACER	1	1	1	1	
18	4SS-23158-L0	.GASKET	1	1	1	1	
19	4SS-23141-40	.SPRING, FRONT FORK (K=0.41)	1	1	1	1	
20	3JD-2312G-L0	.PLUG	1	1	1	1	
21	5DH-23103-00	FRONT FORK ASSY (R.H)	1		1	1	
	5DH-23103-10	FRONT FORK ASSY (R.H)		1			
22	5DH-23136-L0	.TUBE, OUTER (RIGHT)	1	1	1	1	
23	5DH-23110-L0	.INNER TUBE COMP.1	1	1	1	1	
24	4SS-23171-L0	.PISTON, FRONT FORK	1	1	1	1	
25	4SS-23125-L0	.METAL, SLIDE 1	1	1	1	1	

5DH1100-8220

C13



5DH1100-8220

FIG. 22 FRONT FORK

REF. NO.	PART NO.	DESCRIPTION	5DH1	5DH2	5DH3	5DH4	REMARKS
26	4SS-23146-L0	.WASHER, OIL SEAL	1	1	1	1	
27	5DH-23145-L0	.OIL SEAL	1	1	1	1	
28	4SS-23153-L0	.RING, SNAP	1	1	1	1	
29	4SS-23144-L0	.SEAL, DUST	1	1	1	1	
30	5DH-23170-L0	.CYLINDER COMP., FRONT FORK	1	1	1	1	
31	5DH-2316A-L0	.VALVE COMP.	1	1	1	1	
32	5DH-23111-L0	.BOLT, CAP	1	1	1	1	
33	5DH-23142-L0	.SEAT, SPRING UPPER	1	1	1	1	
34	5DH-23393-L0	.NUT, SPECIAL	1	1	1	1	
35	5DH-23195-L0	.RUBBER	1	1	1	1	
36	5DH-23149-L0	.WASHER, SPRING UPPER	1	1	1	1	
37	5DH-23118-L0	.SPACER	1	1	1	1	
38	4SS-23158-L0	.GASKET	1	1	1	1	
39	4SS-23141-40	.SPRING, FRONT FORK (K=0.41)	1	1	1	1	
40	3JD-2312G-L0	.PLUG	1	1	1	1	
41	5DH-23340-L0	UNDER BRACKET COMP.	1	1	1	1	
42	95021-08040	BOLT, FLANGE	8	8	8	8	
43	4SS-2314G-L0	PROTECTOR GUIDE COMP., 2	1	1	1	1	
44	5DH-2314F-L0	PROTECTOR GUIDE COMP., 1	1	1	1	1	
45	4SS-23346-L0	BOLT 1	2	2	2	2	
46	5DH-2314J-00	PROTECTOR COMP., 2	1	1	1	1	
47	5DH-2314H-00	PROTECTOR COMP., 1	1	1	1	1	
48	3SP-23356-L0	BOLT 2	6	6	6	6	
49	4EW-2331E-L0	GUIDE, CABLE	1	1	1	1	
50	4XL-2153A-10	EMBLEM, YAMAHA	1	1	1	1	
51	4XL-2153A-10	EMBLEM, YAMAHA	1	1	1	1	

C14

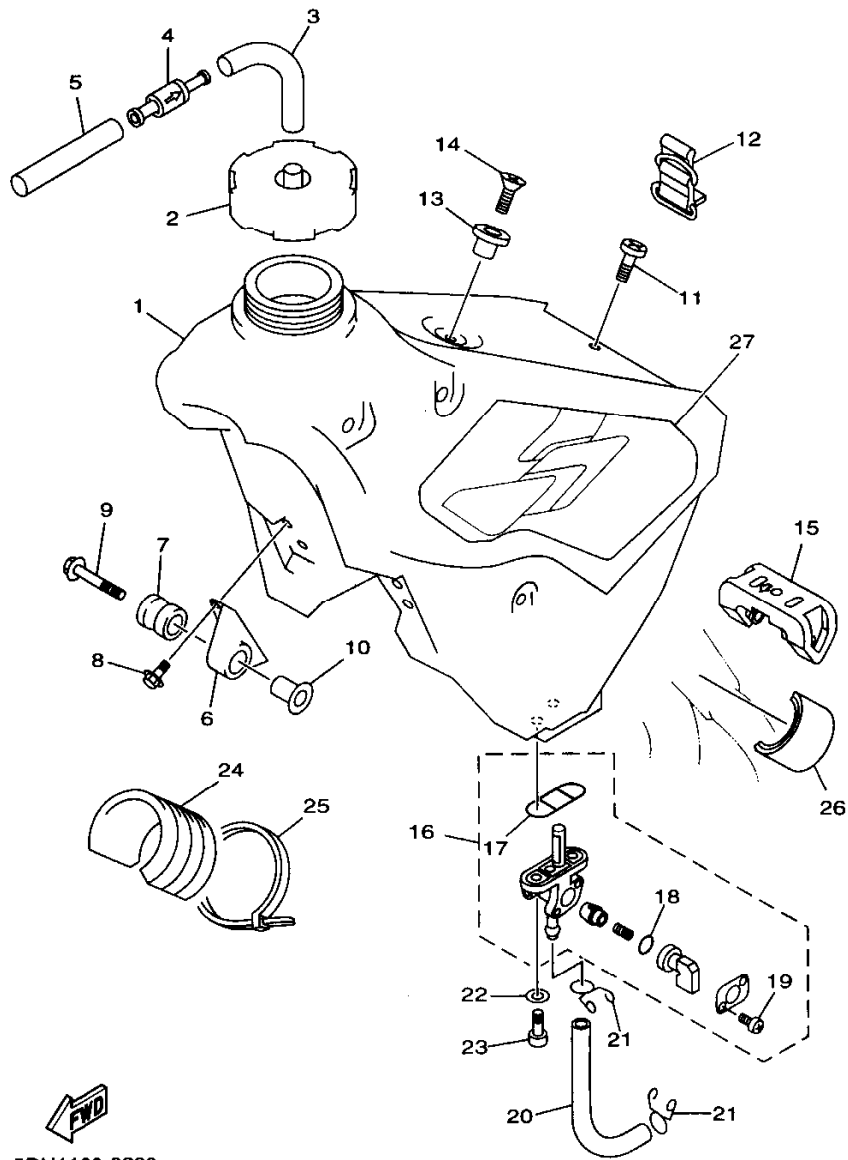

5DH1100-8230

FIG. 23 FUEL TANK

REF. NO.	PART NO.	DESCRIPTION	5DH1	5DH2	5DH3	5DH4	REMARKS
1	4SS-24110-10	FUEL TANK COMP.	1	1	1	1	
2	1UY-24610-00	CAP ASSY	1	1	1	1	
3	90445-09220	HOSE	1	1	1	1	
4	3XJ-24380-00	PIPE JOINT ASSY	1	1	1	1	
5	90445-09104	HOSE	1	1	1	1	
6	24X-24144-00	HOLDER, DAMPER	2	2	2	2	
7	90480-18549	GROMMET	2	2	2	2	
8	95027-06016	BOLT, FLANGE	4	4	4	4	
9	90119-06214	BOLT, WITH WASHER	2	2	2	2	
10	3JD-24186-00	WASHER, SPECIAL	2	2	2	2	
11	98907-06020	SCREW, BIND	1	1	1	1	
12	3SP-24173-00	BAND, TANK FITTING 1	1	1	1	1	
13	4EW-2412F-00	BRACKET, SEAT	1	1	1	1	
14	98707-06025	SCREW, FLAT HEAD	1	1	1	1	
15	4SS-24181-00	DAMPER, LOCATING 1	1	1	1	1	
16	3JD-24500-01	FUEL COCK ASSY 1	1	1	1	1	
17	4X8-24512-00	.O-RING	1	1	1	1	
18	3AJ-24534-00	.SEAL, COCK	1	1	1	1	
19	97801-03008	.SCREW, PAN HEAD	2	2	2	2	
20	90445-114J7	HOSE	1	1	1	1	
21	90467-10008	CLIP	2	2	2	2	
22	90202-05193	WASHER, PLATE	2	2	2	2	
23	90149-06011	SCREW	2	2	2	2	
24	4SS-24182-00	DAMPER, LOCATING 2	1	1	1	1	
25	90465-13275	CLAMP	1	1	1	1	
26	3V6-22358-00	SEAL 1	2	2	2	2	
27	5DH-24240-00	GRAPHIC SET	1	1	1	1	

C15

FIG. 24 SEAT

REF. NO.	PART NO.	DESCRIPTION	5DH1	5DH2	5DH3	5DH4	REMARKS
1	5DH-24770-00	SEMI-DOUBLE SEAT ASSY	1	1	1	1	
2	5DH-24731-00	.COVER, SEAT	1	1	1	1	
3	4SS-24728-00	.BRACKET, SEAT	2	2	2	2	
4	97007-06012	.BOLT	4	4	4	4	
5	92907-06100	.WASHER, SPRING	4	4	4	4	

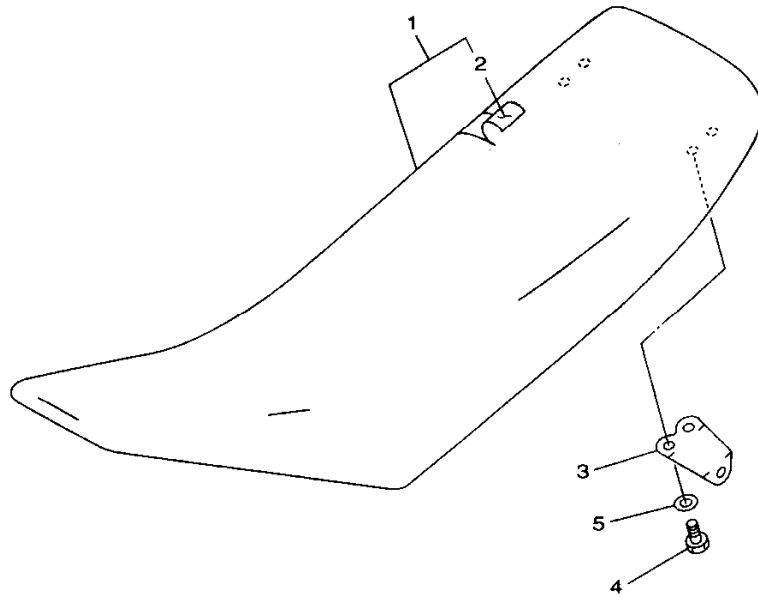

4SS1100-6240

D2

FIG. 25 FRONT WHEEL

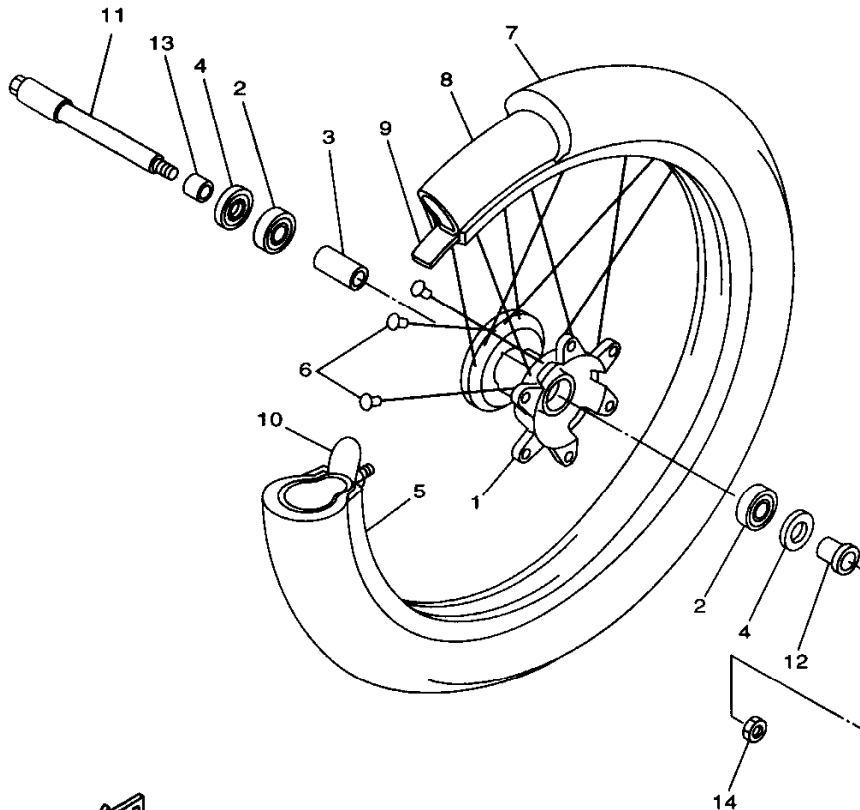

REF. NO.	PART NO.	DESCRIPTION	SDH1	SDH2	SDH3	SDH4	REMARKS
1	4SS-25111-00	HUB, FRONT	1	1	1	1	
2	93306-90403	BEARING	2	2	2	2	
3	5DH-25117-00	SPACER, BEARING	1	1	1	1	
4	93102-26468	OIL SEAL	2	2	2	2	
5	94416-21509	RIM (1.60-21)	1	1	1	1	
6	4DA-25104-00	SPOKE SET, FRONT	1	1	1	1	
7	94108-217X2	TIRE (80/100-21 K490)	1			1	FOR USA/ZAF
	94108-2112Y	TIRE (80/100-21 D755F)	1	1			DUNLOP
	94108-2110Y	TIRE (80/100-21 51M M77)				1	FOR CAN DUNLOP
							BRIDGESTONE
8	94227-21101	TUBE (80/100-21 TR4 BTL)	1	1		1	DUNLOP
	94209-21229	TUBE (80/100C-21 TR4)				1	BRIDGESTONE
9	94307-21145	BAND, RIM (70-80/100-21)	1	1		1	DUNLOP
	94330-21084	BAND, RIM (3.00-21)				1	BRIDGESTONE
10	2J5-25394-01	SPACER, BEAD	1	1	1	1	
11	4SS-25181-00	AXLE, WHEEL	1	1	1	1	
12	5DH-25183-00	COLLAR, WHEEL	1	1	1	1	
13	5DH-25186-00	COLLAR, WHEEL	1	1	1	1	
14	90179-16672	NUT	1	1	1	1	

4SS1100-6250

D3

FIG. 26 FRONT BRAKE CALIPER

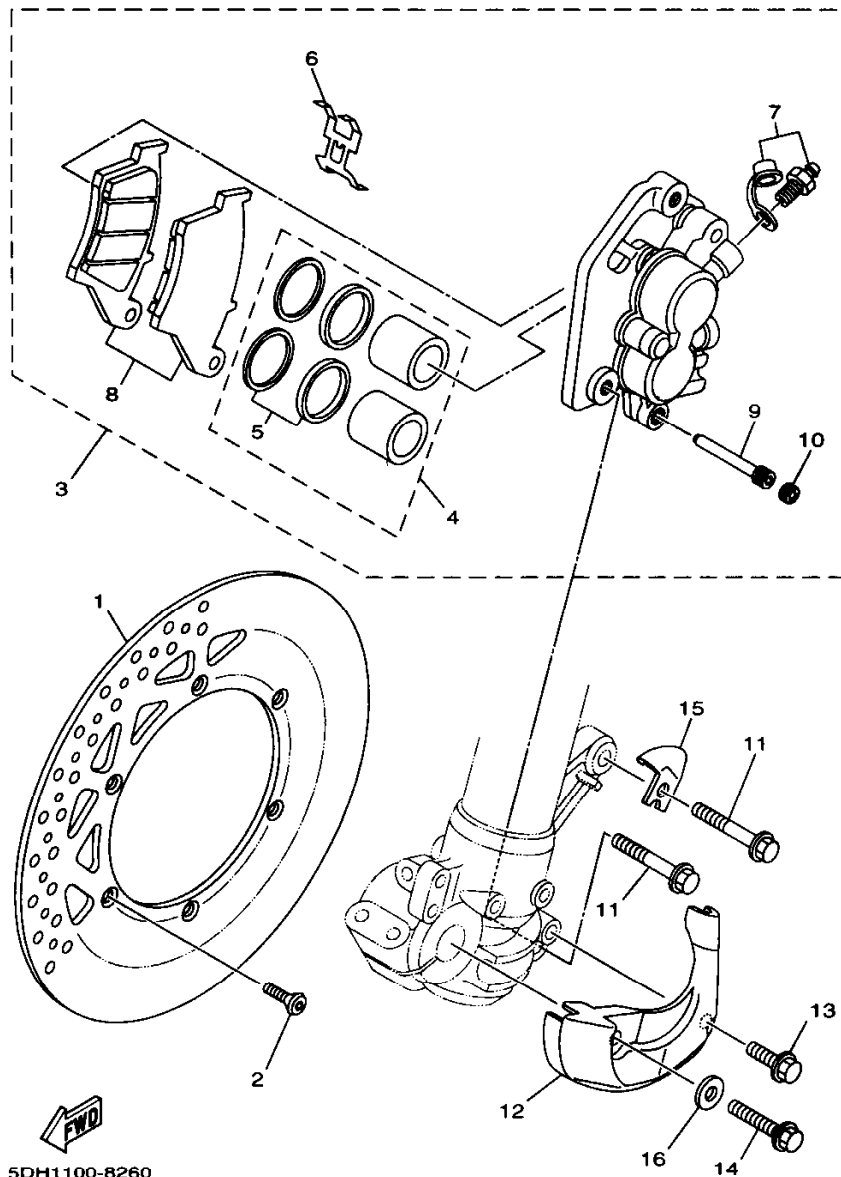

SDH1100-8260

D4

REF. NO.	PART NO.	DESCRIPTION					REMARKS
			5DH1	5DH2	5DH3	5DH4	
1	4XM-2582T-00	DISC, BRAKE	1	1	1	1	
2	90149-06272	SCREW	6	6	6	6	
3	5DH-2580T-00	CALIPER ASSY (LEFT)	1		1	1	
	5DH-2580T-10	CALIPER ASSY (LEFT)		1			
4	4EW-W0057-00	.PISTON ASSY, CALIPER	1	1	1	1	
5	3JD-W0047-00	..CALIPER SEAL KIT	1	1	1	1	
6	5DH-25919-00	.SUPPORT, PAD	1	1	1	1	
7	1UY-W0048-50	.BLEED SCREW KIT	1	1	1	1	
8	5DH-W0045-00	.BRAKE PAD KIT	1		1	1	
	5DH-W0045-10	.BRAKE PAD KIT		1			
9	5DH-25933-00	.PIN, PAD	1	1	1	1	
10	5DH-25916-00	.PLUG	1	1	1	1	
11	90105-08659	BOLT, WASHER BASED	2	2	2	2	
12	5DH-2314E-00	COVER, HOSE	1	1	1	1	
13	95827-06012	BOLT, FLANGE	1	1	1	1	
14	95027-08020	BOLT, FLANGE	1	1	1	1	
15	5DH-25875-00	HOLDER, BRAKE HOSE 1	1	1	1	1	
16	92907-08200	WASHER	1	1	1	1	

FIG. 27 REAR WHEEL

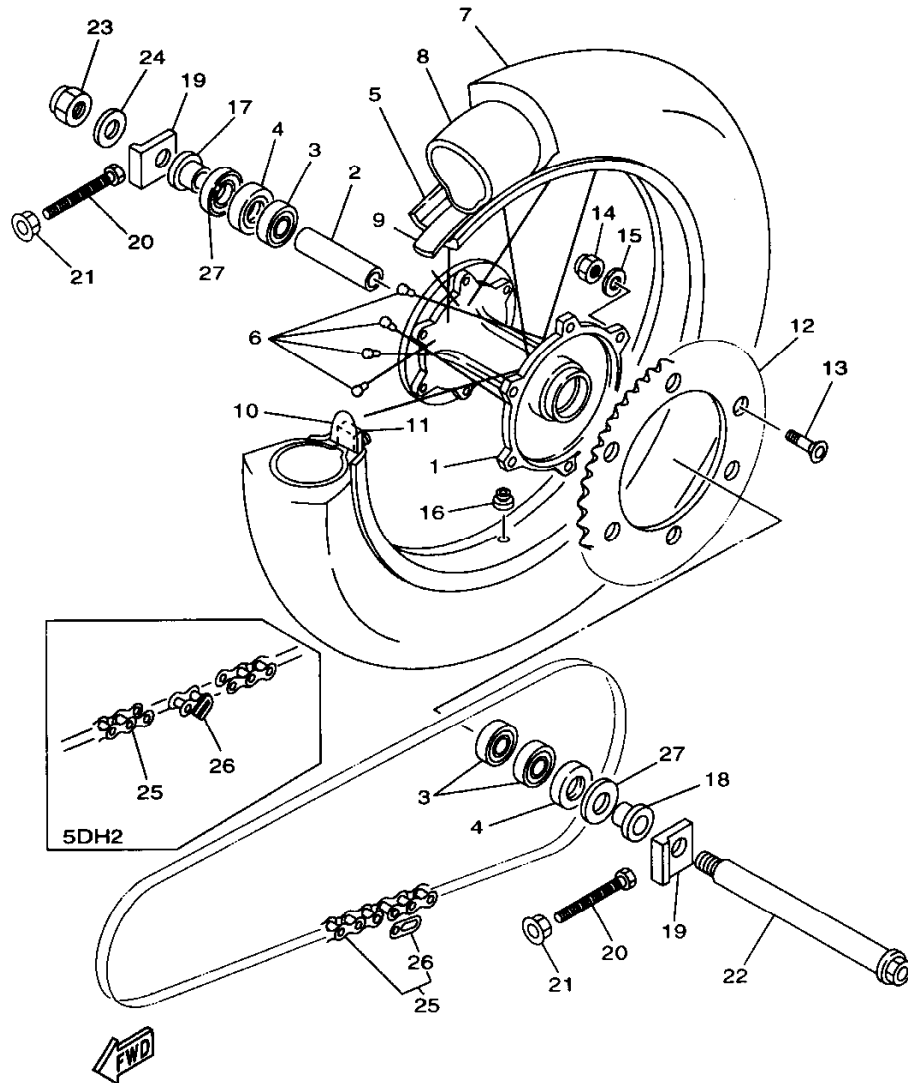

5DH1100-8270

D5

REF. NO.	PART NO.	DESCRIPTION	5DH1	5DH2	5DH3	5DH4	REMARKS
1	4EW-25311-00	HUB, REAR	1	1	1	1	
2	4EW-25317-00	SPACER, BEARING	1	1	1	1	
3	93306-00418	BEARING	3	3	3	3	
4	93106-28023	OIL SEAL	2	2	2	2	
5	94418-19537	RIM (1.85-19)	1	1	1	1	
6	4XM-25304-00	SPOKE SET, REAR	1	1	1	1	
7	94110-1900X	TIRE (100/90-19 57M K695)	1			1	FOR USA/ZAF DUNLOP
	94110-1913B	TIRE (100/90-19 D755)	1	1			FOR CAN DUNLOP
	94110-1911A	TIRE (100/90-19 57M M78A)			1		BRIDGESTONE
8	94210-19224	TUBE(100/90-19 TR4 BTL)	1	1		1	DUNLOP
	94210-19222	TUBE(3.25-19)			1		BRIDGESTONE
9	94321-19135	BAND, RIM (90-100/90-19)	1	1		1	DUNLOP
	94316-19156	BAND, RIM (1.85-19)			1		BRIDGESTONE
10	4XM-25394-00	SPACER, BEAD	1	1	1	1	
11	4XM-25364-00	DAMPER	1	1	1	1	
12	4SS-25448-00	SPROCKET, DRIVEN (48T)	1	1	1	1	STD
	4SS-25447-00	SPROCKET, DRIVEN (47T)	1	1	1	1	AP
	4SS-25449-00	SPROCKET, DRIVEN (49T)	1	1	1	1	AP
	4SS-25450-00	SPROCKET, DRIVEN (50T)	1	1	1	1	AP
	4SS-25451-00	SPROCKET, DRIVEN (51T)	1	1	1	1	AP
	4SS-25452-00	SPROCKET, DRIVEN (52T)	1	1	1	1	AP
13	90109-081G1	BOLT	6	6	6	6	
14	95617-08200	NUT, SELF-LOCKING	6	6	6	6	
15	90201-08326	WASHER, PLATE	6	6	6	6	
16	90480-08608	GROMMET	1	1	1	1	
17	90387-2000B	COLLAR	1	1	1	1	
18	90387-2000C	COLLAR	1	1	1	1	

FIG. 27 REAR WHEEL

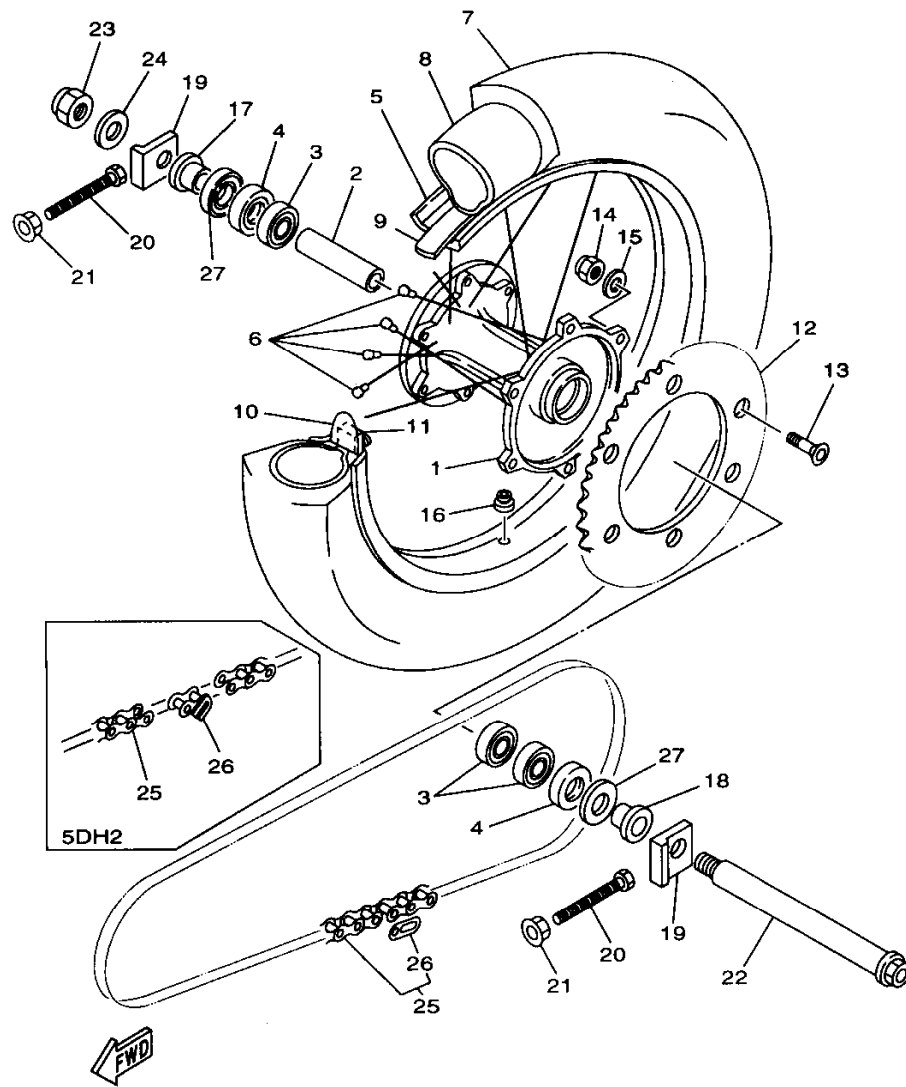

REF. NO.	PART NO.	DESCRIPTION	5DH1	5DH2	5DH3	5DH4	REMARKS
19	3SP-25388-00	PULLER, CHAIN 1	2	2	2	2	
20	90101-08777	BOLT	2	2	2	2	
21	95707-08500	NUT, FLANGE	2	2	2	2	
22	3JD-25381-01	AXLE, WHEEL	1	1	1	1	
23	90185-18104	NUT, SELF-LOCKING	1	1	1	1	
24	92907-18600	WASHER	1	1	1	1	
25	94581-68112	CHAIN (D.I.D.520DM 112LL)	1		1	1	
	94561-60111	CHAIN (REGINA 135RX1-A 111L)		1			
26	94681-68001	JOINT, CHAIN	1		1	1	
	94661-55001	JOINT, CHAIN		1			
27	4V4-25367-00	COVER, HUB DUST	2	2	2	2	

5DH1100-8270

D6

FIG. 28 REAR BRAKE CALIPER

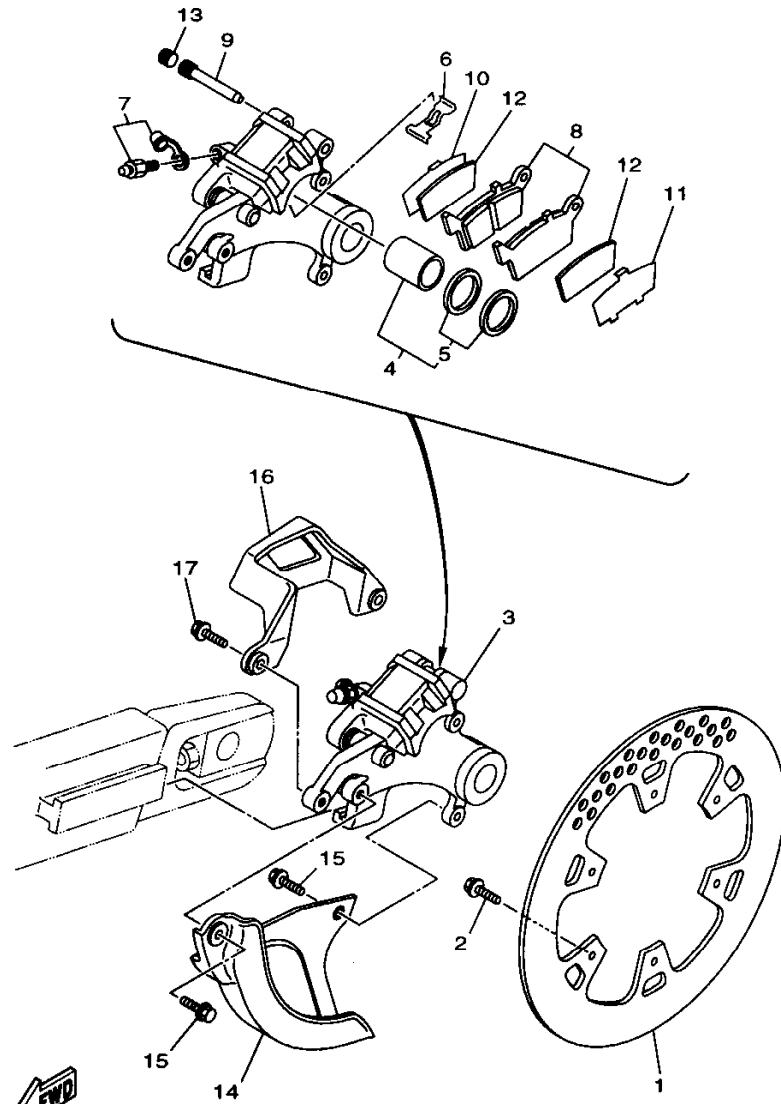

REF. NO.	PART NO.	DESCRIPTION	SDH1	SDH2	SDH3	SDH4	REMARKS
1	5DH-2582W-00	DISC, REAR BRAKE 2	1	1	1	1	
2	90109-065G4	BOLT	6	6	6	6	
3	5DH-2580W-00	CALIPER ASSY, REAR 2	1	1	1	1	
4	3LD-W0057-00	.PISTON ASSY, CALIPER	1	1	1	1	
5	3JD-W0047-00	..CALIPER SEAL KIT	1	1	1	1	
6	5DH-25919-50	.SUPPORT, PAD	1	1	1	1	
7	1UY-W0048-50	.BLEED SCREW KIT	1	1	1	1	
8	5DH-W0046-00	.BRAKE PAD KIT 2	1	1	1	1	
9	8CR-25924-00	.PIN, PAD	1	1	1	1	
10	5DH-25828-50	.SHIM, CALIPER	1	1	1	1	
11	5DH-25827-50	.SHIM, CALIPER	1	1	1	1	
12	5DH-22898-50	.INSULATOR, HEAT	2	2	2	2	
13	5DH-25916-00	.PLUG	1	1	1	1	
14	5DH-25718-00	PROTECTOR, DISK BRAKE	1	1	1	1	
15	95027-06012	BOLT, FLANGE	2	2	2	2	
16	4GY-27491-00	PROTECTOR	1	1	1	1	
17	95027-06016	BOLT, FLANGE	2	2	2	2	

5DH1100-8280

D7

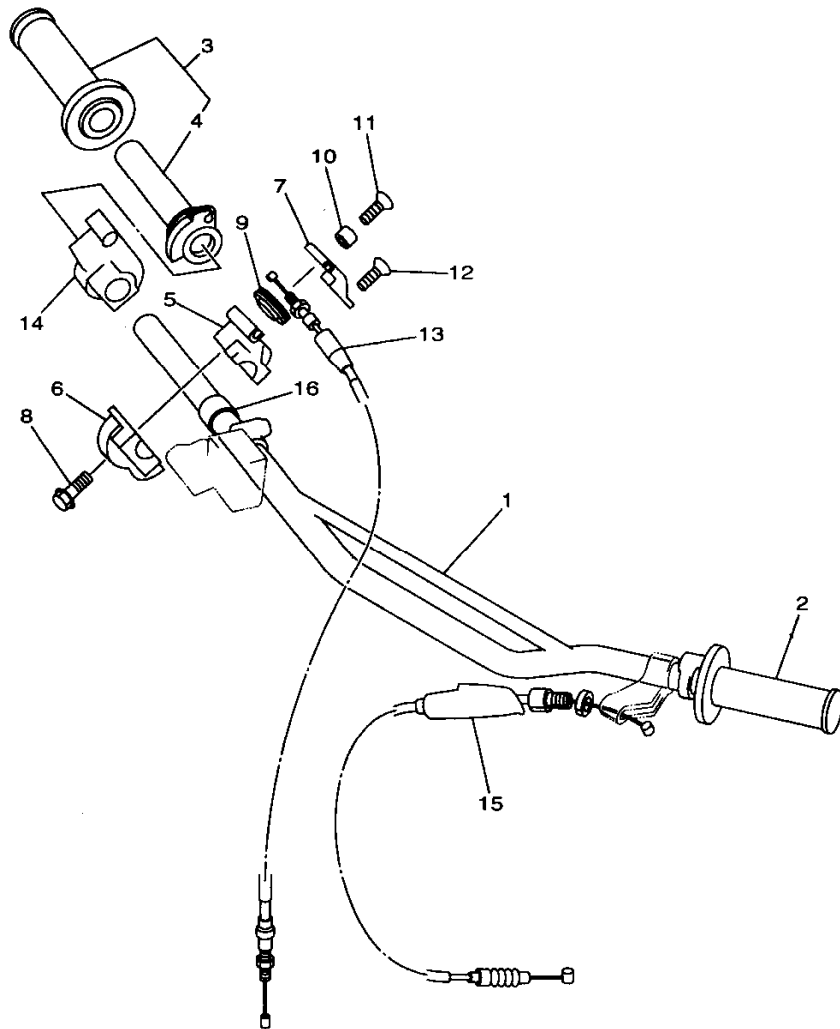

4XL4100-7290

FIG. 29 STEERING HANDLE. CABLE

REF. NO.	PART NO.	DESCRIPTION	SDH1	SDH2	SDH3	SDH4	REMARKS
1	4XM-26111-00	HANDLEBAR	1	1	1	1	
2	4GY-26241-00	GRIP (LEFT)	1	1	1	1	
3	4XM-26240-00	GRIP ASSY	1	1	1	1	
4	4XM-26243-00	.TUBE, THROTTLE GUIDE	1	1	1	1	
5	4SS-26281-00	CAP, GRIP UPPER	1	1	1	1	
6	4SS-26282-10	CAP, GRIP LOWER	1	1	1	1	
7	4SS-2628H-00	CAP, WIRE	1	1	1	1	
8	95027-06025	BOLT, FLANGE	2	2	2	2	
9	4SS-26273-00	ROTOR	1	1	1	1	
10	4SS-26259-00	COLLAR	1	1	1	1	
11	4SS-26256-00	SCREW, GRIP END	1	1	1	1	
12	4SS-2632G-00	SCREW	1	1	1	1	
13	4SS-26311-01	CABLE, THROTTLE 1	1	1	1	1	
14	4SS-26287-01	COVER, CAP GRIP	1	1	1	1	
15	4JY-26335-00	CABLE, CLUTCH	1	1	1	1	
16	90387-227H7	COLLAR	1	1	1	1	

D8

FIG. 30 FRONT MASTER CYLINDER

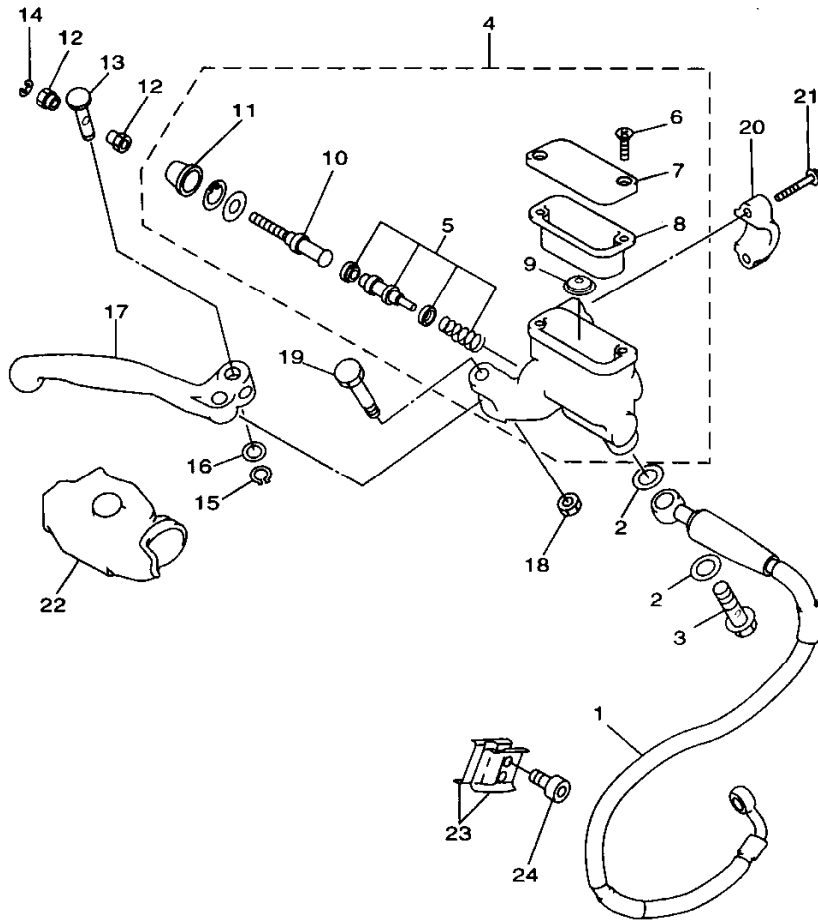

REF. NO.	PART NO.	DESCRIPTION	5DH1	5DH2	5DH3	5DH4	REMARKS
1	5DH-25872-00	HOSE, BRAKE 1	1	1	1	1	
2	90201-10118	WASHER, PLATE	4	4	4	4	
3	90401-10168	BOLT, UNION	2	2	2	2	
4	4SS-W2587-00	MASTER CYLINDER SUB ASSY	1	1	1	1	
5	4SS-W0041-00	.CYLINDER KIT, MASTER	1	1	1	1	
6	98706-04012	.SCREW, FLAT HEAD	2	2	2	2	
7	4SS-25852-00	.CAP, RESERVOIR	1	1	1	1	
8	4SS-25854-00	.DIAPHRAGM, RESERVOIR	1	1	1	1	
9	4SS-25889-00	.SEPARATOR ASSY	1	1	1	1	
10	4SS-25880-00	.PUSH ROD COMP.	1	1	1	1	
11	4SS-25868-00	.BOOT, MASTER CYLINDER	1	1	1	1	
12	4SS-2538E-00	NUT, ADJUSTING	2	2	2	2	
13	4SS-83913-00	COLLAR, LEVER 1	1	1	1	1	
14	3YX-25866-10	CIRCLIP	1	1	1	1	
15	4SS-25866-00	CIRCLIP	1	1	1	1	
16	4SS-2583G-00	WASHER	1	1	1	1	
17	4SS-83922-01	LEVER 2	1	1	1	1	
18	95606-06100	NUT, U	1	1	1	1	
19	4SS-2589F-00	BOLT, LEVER	1	1	1	1	
20	3YK-25867-00	BRACKET, MASTER CYLINDER	1	1	1	1	
21	4SS-25833-00	BOLT, FITTING	2	2	2	2	
22	4SS-26372-00	COVER, HANDLE LEVER 1	1	1	1	1	
23	90465-16258	CLAMP	2	2	2	2	
24	91317-06014	BOLT	2	2	2	2	

4SS1100-6300

D9

FIG. 31 STAND. FOOTREST

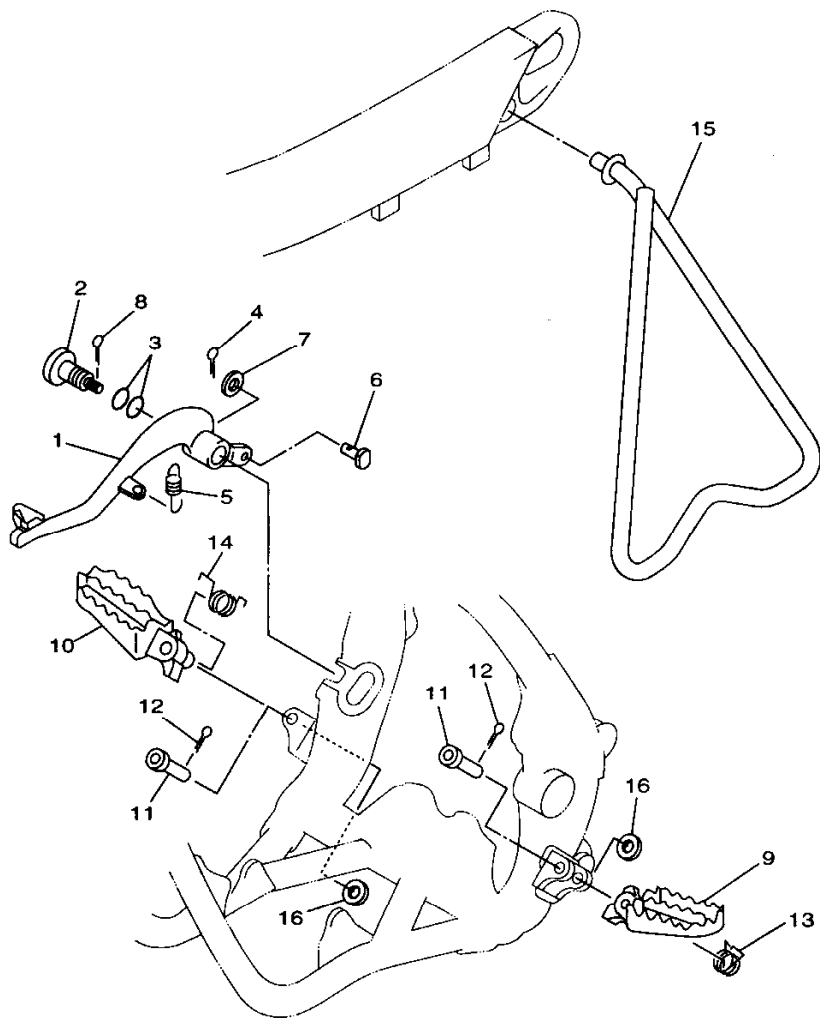

REF. NO.	PART NO.	DESCRIPTION					REMARKS
			5DH1	5DH2	5DH3	5DH4	
1	4XM-27200-00	PEDAL, BRAKE	1	1	1	1	
2	4SS-27217-00	BOLT	1	1	1	1	
3	93210-11073	O-RING	2	2	2	2	
4	91401-20012	PIN, COTTER	1	1	1	1	
5	90506-16500	SPRING, TENSION	1	1	1	1	
6	90240-08120	PIN, CLEVIS	1	1	1	1	
7	90201-08089	WASHER, PLATE	1	1	1	1	
8	90468-16191	CLIP	1	1	1	1	
9	4XM-27411-00	FOOTREST 1	1	1	1	1	
10	4XM-27421-00	FOOTREST 2	1	1	1	1	
11	90240-10142	PIN, CLEVIS	2	2	2	2	
12	91401-25015	PIN, COTTER	2	2	2	2	
13	90508-282B8	SPRING, TORSION	1	1	1	1	
14	90508-282B9	SPRING, TORSION	1	1	1	1	
15	3SP-27311-00	STAND, SIDE	1	1	1	1	
16	90201-10119	WASHER, PLATE	2	2	2	2	



4XL4100-7310

D10

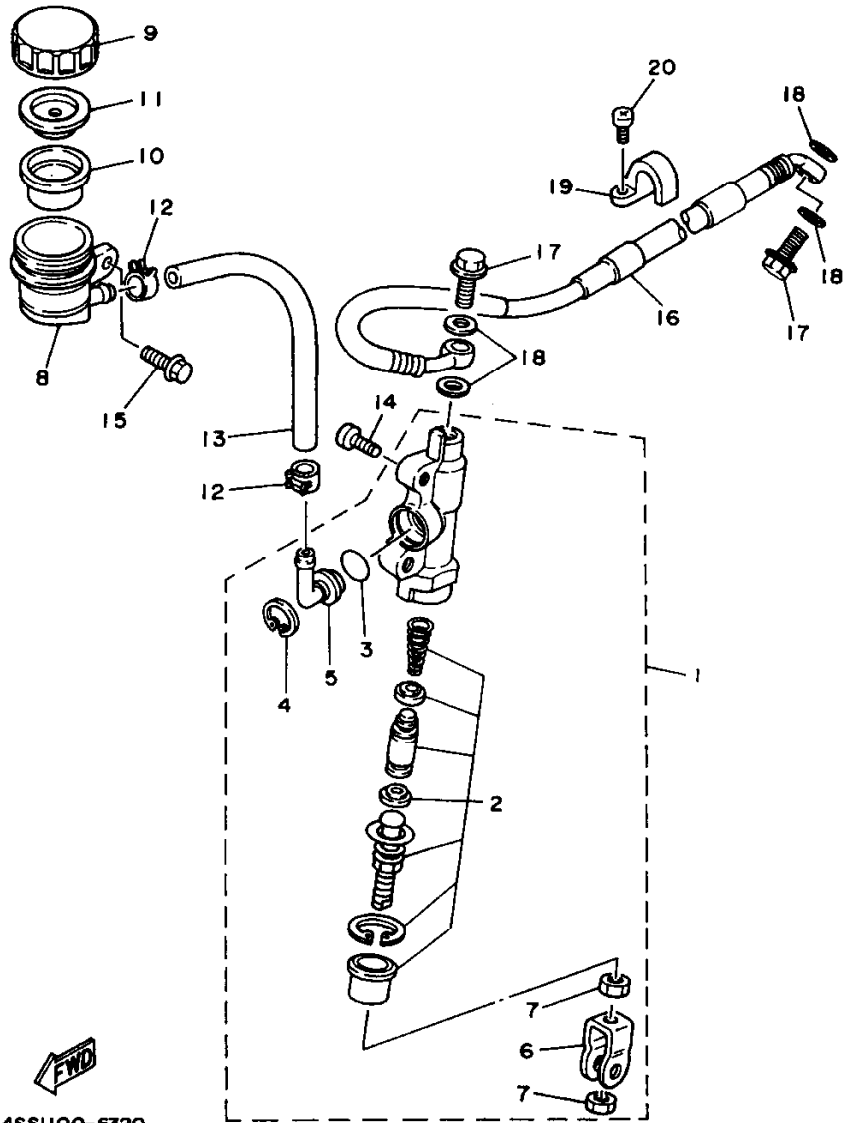

4SS1100-6320

FIG. 32 REAR MASTER CYLINDER

REF. NO.	PART NO.	DESCRIPTION	SDH1	SDH2	SDH3	SDH4	REMARKS
1	3SP-2583V-00	RR. MASTER CYLINDER ASSY.	1	1	1	1	
2	4SS-W0042-50	.CYLINDER KIT, MASTER	1	1	1	1	
3	93210-15620	.O-RING	1	1	1	1	
4	2VN-25866-00	.CIRCLIP	1	1	1	1	
5	2VN-2582A-50	.JOINT	1	1	1	1	
6	3SP-27222-00	.JOINT	1	1	1	1	
7	4SS-27218-00	.NUT	2	2	2	2	
8	4EW-25894-00	TANK, RESERVOIR	1	1	1	1	
9	3XP-25852-50	CAP, RESERVOIR	1	1	1	1	
10	2VN-25854-00	DIAPHRAGM, RESERVOIR	1	1	1	1	
11	2VN-25855-00	BUSH,DIAPHRAGM	1	1	1	1	
12	90467-12053	CLIP	2	2	2	2	
13	90445-137H9	HOSE	1	1	1	1	
14	92014-06016	BOLT, BUTTON HEAD	2	2	2	2	
15	95027-06012	BOLT, FLANGE	1	1	1	1	
16	5DH-25873-00	HOSE, BRAKE 2	1	1	1	1	
17	90401-10168	BOLT, UNION	2	2	2	2	
18	90201-10118	WASHER, PLATE	4	4	4	4	
19	2VM-25876-00	HOLDER, BRAKE HOSE 2	2	2	2	2	
20	97780-50510	SCREW, TAPPING	4	4	4	4	

D11

FIG. 33 GENERATOR

REF. NO.	PART NO.	DESCRIPTION	SDH1	SDH2	SDH3	SDH4	REMARKS
1	4SS-85560-00	BASE ASSY	1	1	1	1	
2	4SS-85550-00	ROTOR ASSY	1	1	1	1	
3	90149-06011	SCREW	3	3	3	3	
4	95317-10600	NUT	1	1	1	1	
5	90201-10591	WASHER, PLATE	1	1	1	1	

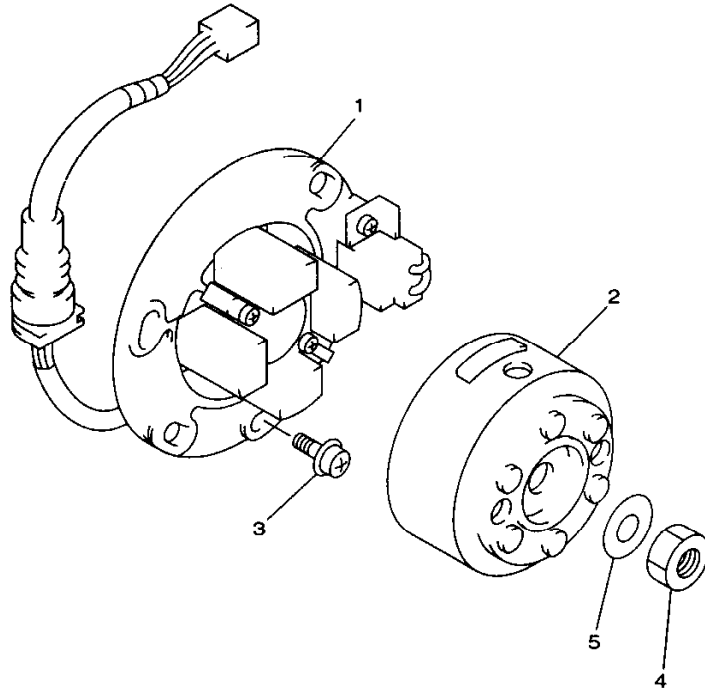

4SS1100-6330

D12

FIG. 34 HANDLE SWITCH. LEVER

REF. NO.	PART NO.	DESCRIPTION	SDH1	SDH2	SDH3	SDH4	REMARKS
1	38V-82911-00	HOLDER, LEVER 1	1	1	1	1	
2	38V-82913-00	HOLDER, LEVER LOWER 1	1	1	1	1	
3	4GY-83912-00	LEVER 1	1	1	1	1	
4	90109-06799	BOLT	1	1	1	1	
5	95607-06100	NUT, U	1	1	1	1	
6	97007-05016	BOLT	2	2	2	2	
7	90123-08090	BOLT	1	1	1	1	
8	90179-08401	NUT	1	1	1	1	
9	23X-83976-00	SWITCH, HANDLE 1	1	1	1	1	
10	90464-13077	CLAMP	2	2	2	2	

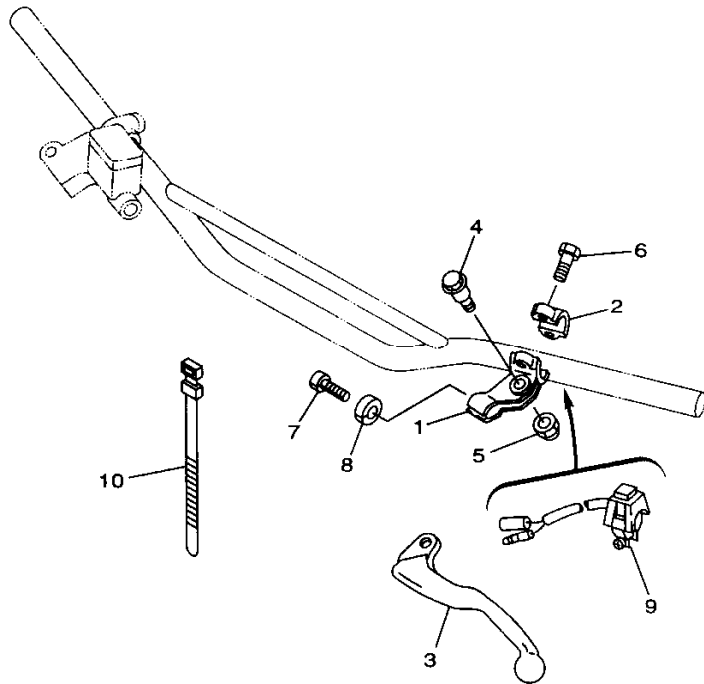

4SS1100-6340

D13

FIG. 35 ELECTRICAL 1

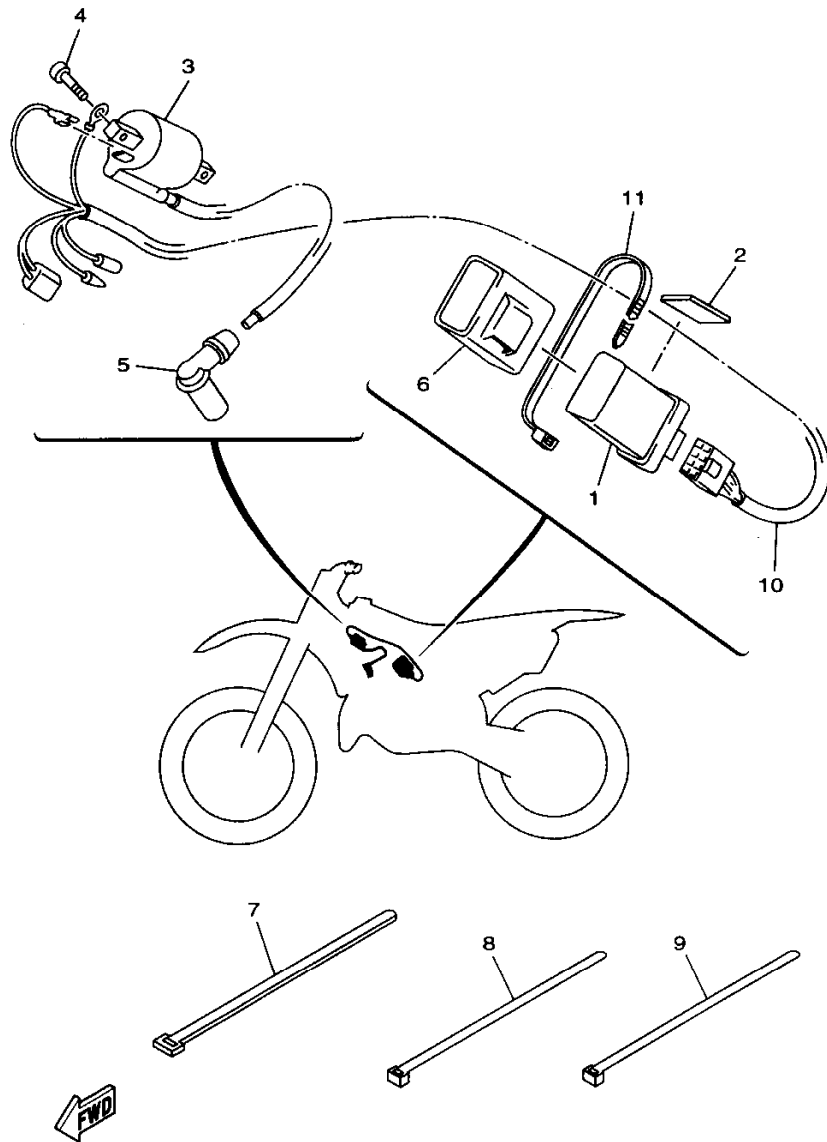

5DH1100-8350

REF. NO.	PART NO.	DESCRIPTION	5DH1	5DH2	5DH3	5DH4	REMARKS
1	4XM-85540-00	C.D.I. UNIT ASSY	1	1	1	1	
2	22F-2139X-00	DAMPER	1	1	1	1	
3	4SS-82310-00	IGNITION COIL ASSY	1	1	1	1	
4	91317-06016	BOLT	2	2	2	2	
5	4PE-82370-00	PLUG CAP ASSY	1	1	1	1	
6	4SS-85546-01	BAND	1	1	1	1	
7	90464-50255	CLAMP	2	2	2	2	
8	90464-13073	CLAMP	1	1	1	1	
9	90465-13275	CLAMP	1	1	1	1	
10	5DH-82509-00	WIRE, SUB LEAD	1	1	1	1	
11	90460-15126	CLAMP, HOSE	1	1	1	1	

D14

FIG. 36 ALTERNATE (CHASSIS)

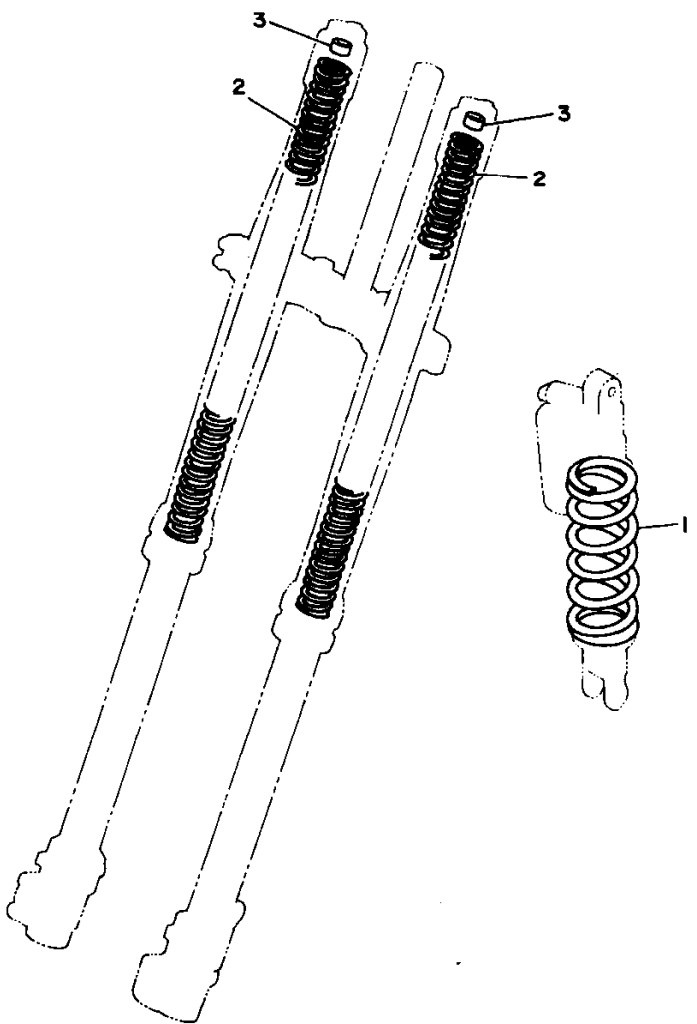

REF. NO.	PART NO.	DESCRIPTION	SDH1	SDH2	SDH3	SDH4	REMARKS
1	5DH-22212-70	SPRING (K=4.4)	1	1	1	1	AP
	5DH-22212-10	SPRING (K=4.6)	1	1	1	1	AP
	5DH-22212-20	SPRING (K=4.8)	1	1	1	1	AP
	5DH-22212-30	SPRING (K=5.0)	1	1	1	1	AP
	5DH-22212-40	SPRING (K=5.2)	1	1	1	1	AP
	5DH-22212-50	SPRING (K=5.4)	1	1	1	1	AP
	5DH-22212-60	SPRING (K=5.6)	1	1	1	1	AP
2	4SS-23141-10	SPRING, FRONT FORK (K=0.38)	2	2	2	2	AP
	4SS-23141-20	SPRING, FRONT FORK (K=0.39)	2	2	2	2	AP
	4SS-23141-30	SPRING, FRONT FORK (K=0.40)	2	2	2	2	AP
	4SS-23141-40	SPRING, FRONT FORK (K=0.41)	2	2	2	2	AP
	4SS-23141-50	SPRING, FRONT FORK (K=0.42)	2	2	2	2	AP
	4SS-23141-60	SPRING, FRONT FORK (K=0.43)	2	2	2	2	AP
	4SS-23141-70	SPRING, FRONT FORK (K=0.44)	2	2	2	2	AP
3	4SS-23364-L0	COLLAR 2	1	1	1	1	UN



3XJ1100-1360

D15

FIG. 37 OPTIONAL PARTS 1

REF. NO.	PART NO.	DESCRIPTION	SDH1	SDH2	SDH3	SDH4	REMARKS
1	4XM-11630-10	PISTON ASSY (0.25MM O/S)	1	1	1	1	
2	4XM-11631-00-B0	.PISTON (STD)	1	1	1	1	
3	4JY-11611-00	.RING, PISTON	1	1	1	1	
4	4XM-11633-00	.PIN, PISTON	1	1	1	1	
5	93450-16068	.CIRCLIP	2	2	2	2	
6	4XM-11650-00	CONNECTING ROD ASSY	1	1	1	1	
7	4PE-11651-02	.ROD, CONNECTING	1	1	1	1	
8	3JD-11681-02	.PIN, CRANK 1	1	1	1	1	
9	90209-22248	.WASHER	2	2	2	2	
10	93310-522P7	.BEARING	1	1	1	1	
11	93310-315S4	.BEARING	1	1	1	1	

E2

INDEX

NUMERICAL INDEX

PART NO.	GRID NO.	PART NO.	GRID NO.	PART NO.	GRID NO.	PART NO.	GRID NO.	PART NO.	GRID NO.	PART NO.	GRID NO.
4SS-W0041-00	D- 9	4SS-11990-00	B- 4	137-14143-68	B- 10	1LX-15660-03	B- 14	4XL-2153A-10	C- 14	5DH-22253-00	C- 11
4SS-W0042-50	D- 11	4JY-11991-01	B- 3	137-14143-70	B- 10	3XJ-16111-00	B- 15	5BE-21611-10	C- 7	4SS-22355-00	C- 9
5DH-W0045-00	D- 4	4JY-11993-01	B- 3	137-14143-72	B- 10	4JY-16150-02	B- 15	4ES-21642-00	C- 7	3V6-22358-00	C- 15
5DH-W0045-10	D- 4	4JY-11995-00	B- 3	137-14143-74	B- 10	3XJ-16181-00	B- 15	4SS-21711-00	C- 8	4EW-22474-00	C- 11
5DH-W0046-00	D- 7	4SS-1240A-00	B- 7	4PE-14147-00	B- 10	5DH-16321-00	B- 15	4EW-2172A-10	C- 8	3JE-22475-00	C- 11
3JD-W0047-00	D- 4	4JY-12422-00	B- 6	4PE-1416A-00	B- 10	3XJ-16324-00	B- 15		C- 8	5DH-22898-50	D- 7
	D- 7	4JY-12428-00	B- 6	3JE-14171-00	B- 9	3JD-16340-00	B- 15	4SS-21721-00	C- 8	5DH-23102-00	C- 13
1UY-W0048-50	D- 4	5DH-12451-00	B- 6	4PE-14185-00	B- 9	4EX-16351-00	B- 15	5DH-2173E-00	C- 8	5DH-23102-10	C- 13
	D- 7	5DH-12459-00	B- 6	353-14186-00	B- 9	3SB-16356-00	B- 15	5DH-2173F-00	C- 8	5DH-23103-00	C- 13
3LD-W0057-00	D- 7	4SS-12461-00	B- 7	4PE-14194-00	B- 9	4EX-16371-00	B- 15	4SS-21731-10	C- 8	5DH-23103-10	C- 13
4EW-W0057-00	D- 4	22W-12462-00	B- 7	2HH-14197-00	B- 9	4EX-16382-00	B- 15	4SS-21741-10	C- 8	5DH-23110-L0	C- 13
4SS-W2587-00	D- 9	4SS-12481-00	B- 7	3X3-14197-00	B- 9	4XM-17121-00	C- 2	3JD-21748-00	C- 7	5DH-23111-L0	C- 13
4JY-11111-01	B- 2	4SS-12482-00	B- 7	4PE-14197-00	B- 10	4EX-17131-01	C- 2	5DH-21781-00	C- 8		C- 14
4JY-11166-00	B- 2	4SS-12483-00	B- 7	4PE-14243-00	B- 9	4EX-17151-00	C- 2		C- 8	5DH-23118-L0	C- 13
4SS-1131A-02	B- 2	4SS-12484-00	B- 7	4PE-14261-01	B- 9	4XM-17161-00	C- 2	5DH-22110-00	C- 9		C- 14
4JY-1131E-00	B- 2	353-13115-01	B- 12	4SS-14401-02	B- 8	4XM-17211-00	C- 2	156-22127-00	C- 9	3JD-23126-L0	C- 13
4SS-1131M-00	B- 2	4PE-13565-00	B- 8	4SS-14417-00	B- 8	4XM-17221-00	C- 2	4XM-22128-00	C- 9		C- 14
4SS-1131V-00	B- 2	4SS-13610-00	B- 8	4XM-14451-00	B- 8	3SR-17231-00	C- 2	5DH-22129-00	C- 9	5DH-23120-L0	C- 13
4SS-11311-10	B- 2	4SS-13613-00	B- 8	4SS-14453-00	B- 8	4EX-17241-00	C- 2	5DH-22141-00	C- 9	4SS-23125-L0	C- 13
4SS-1132A-02	B- 2	4JY-13616-00	B- 8	3JD-14458-01	B- 8	4EX-17251-01	C- 2	4EW-22151-20	C- 9		C- 13
5DH-11351-00	B- 2	5DH-14101-10	B- 9	3JD-14459-01	B- 8	4XM-17261-00	C- 2	5DH-2217A-00	C- 9	5DH-23136-L0	C- 13
4JY-11354-02	B- 3	4PE-14103-00	B- 9	3JD-14462-00	B- 8	4XM-17411-00	C- 2	5DH-2217F-00	C- 10		C- 13
5DH-11400-00	B- 5	3JD-14104-00	B- 9	3JD-14477-00	B- 8	4XM-17421-00	C- 2	3JD-22178-10	C- 6	5DH-2314E-00	D- 4
4SS-11410-10	B- 5	4PE-14107-38	B- 9	3JE-14561-00	B- 9	4SS-18101-00	C- 5	4EW-22178-00	C- 6	5DH-2314F-L0	C- 14
4SS-11420-00	B- 5	4SS-14112-45	B- 10	1FN-14565-00	B- 9	4SS-18110-00	C- 5	4XM-22199-00	C- 9	4SS-2314G-L0	C- 14
4JY-11611-00	B- 5	4SS-14112-50	B- 10	4XM-14610-00	B- 11	3XJ-18122-00	C- 5	5DH-22201-00	C- 11	5DH-2314H-00	C- 14
	E- 2	4SS-14112-55	B- 10	4JY-14615-00	B- 11	4JY-18140-00	C- 4	5DH-22201-10	C- 11	5DH-2314J-00	C- 14
4XM-11630-10	E- 2	3XK-14115-00	B- 9	4SR-1469A-00	B- 11	4JY-18172-00	C- 5	5DH-22201-20	C- 11	4SS-23141-10	D- 15
4XM-11631-00-B0	E- 2	5A0-14116-F0	B- 9	5DH-14753-00	B- 11	3XJ-18173-00	C- 5	5DH-22201-30	C- 11	4SS-23141-20	D- 15
4XM-11631-10-A0	B- 5	5A0-14116-F1	B- 9	565-14771-00	B- 11	3XJ-18178-00	C- 5	5DH-22210-00	C- 11	4SS-23141-30	D- 15
4XM-11631-10-B0	B- 5	5A0-14116-F2	B- 9	256-14919-00	B- 9	3XJ-18182-00	C- 5	5DH-22210-10	C- 11	4SS-23141-40	C- 13
4XM-11631-10-C0	B- 5	5A0-14116-F3	B- 9	5DH-15111-00	B- 12	3XJ-18184-00	C- 5	5DH-22210-20	C- 11		C- 14
4XM-11631-10-D0	B- 5	5A0-14116-F4	B- 9	3R4-15118-00	B- 12	4EW-18185-00	C- 5	5DH-22210-30	C- 11		D- 15
4XM-11633-00	E- 2	4PE-14131-00	B- 9	5DH-15121-00	B- 12	4SS-18511-00	C- 4	5DH-22212-10	C- 11	4SS-23141-50	D- 15
4XM-11633-10	B- 5	87M-14137-00	B- 10	3Y1-15363-00	B- 13	2VN-18512-01	C- 4		D- 15	4SS-23141-60	D- 15
4XM-11650-00	E- 2	3TC-14141-S5	B- 10	1LX-15383-00	C- 2	4SS-18513-00	C- 4	5DH-22212-20	D- 15	4SS-23141-70	D- 15
4PE-11651-02	B- 5	3TC-14141-S6	B- 10	4XM-15383-00	C- 2	4EX-18531-00	C- 4	5DH-22212-30	D- 15	5DH-23142-L0	C- 13
	E- 2	3TC-14141-S7	B- 10	4JY-15411-00	B- 13	4EX-18535-00	C- 4	5DH-22212-40	D- 15		C- 14
3JD-11681-02	B- 5	3TC-14141-S8	B- 10	4JY-15415-00	B- 13	5DH-18541-00	C- 4	5DH-22212-50	D- 15	4SS-23144-L0	C- 13
	E- 2	3TC-14141-S9	B- 10	4EX-15421-00	B- 13	5DH-18562-00	C- 4	5DH-22212-60	D- 15		C- 14
	B- 2	3TC-14141-T0	B- 10	4JY-15431-10	B- 13	5DH-21101-00-PO	C- 6	5DH-22212-70	D- 15	5DH-23145-L0	C- 13
4SS-11832-00	B- 4	4KM-14142-40	B- 9	4JY-15451-01	B- 13	5DH-21190-00-PO	C- 6	3SP-22213-00	C- 11		C- 14
5X5-11911-01	B- 4	4KM-14142-45	B- 9	4JY-15462-00	B- 13	5DH-21274-00	C- 6	5DH-22214-00	C- 11	4SS-23146-L0	C- 13
5X5-11912-01	B- 4	4KM-14142-50	B- 9	4JY-15463-01	B- 13	1HX-2135F-10	C- 10	5DH-22224-00	C- 11		C- 14
4JY-11915-01	B- 4	4KM-14142-55	B- 10	4DB-15620-03	B- 14	22F-2139X-00	D- 14	4JX-22226-00	C- 11	5DH-23149-L0	C- 13
5X4-11921-02	B- 4	4KM-14142-60	B- 10	4DB-15621-03	B- 14	4SS-21425-00	C- 6		C- 11		C- 14
3JE-11922-01	B- 4	4KM-14142-65	B- 10	1LX-15641-00	B- 14	4DA-21511-20	C- 7	3SP-22234-00	C- 11	4SS-23153-L0	C- 13
5X4-11952-00	B- 4	137-14143-66	B- 10	1LX-15651-00	B- 14	4XL-2153A-10	C- 14	4EW-22253-00	C- 11		C- 14
24X-11953-01	B- 4										

NUMERICAL INDEX

PART NO.	GRID NO.	PART NO.	GRID NO.	PART NO.	GRID NO.	PART NO.	GRID NO.	PART NO.	GRID NO.	PART NO.	GRID NO.
4SS-23158-L0	C- 13	4XM-25304-00	D- 5	5DH-25919-00	D- 4	90105-08494	C- 6	90185-14112	C- 10	90240-10142	D- 10
	C- 14	4EW-25311-00	D- 5	5DH-25919-50	D- 7	90105-08659	D- 4	90185-16127	C- 9	90267-32070	B- 8
5DH-2316A-L0	C- 13	4EW-25317-00	D- 5	8CR-25924-00	D- 7	90105-10323	C- 11	90185-18104	D- 6	90280-03045	B- 5
	C- 14	4XM-25364-00	D- 5	5DH-25933-00	D- 4	90105-10445	B- 15	90201-03313	B- 8	90338-16148	C- 6
5DH-23170-L0	C- 13	4V4-25367-00	D- 6	4XM-26111-00	D- 8	90105-105A2	C- 11	90201-057H5	B- 2		C- 9
	C- 14	4SS-2538E-00	D- 9	4XM-26240-00	D- 8	90105-10733	C- 6		B- 4	90338-21145	C- 6
4SS-23171-L0	C- 13	3JD-25381-01	D- 6	4GY-26241-00	D- 8	90109-06418	B- 15	90201-06060	B- 11	90338-30256	C- 6
	C- 13	3SP-25388-00	D- 6	4XM-26243-00	D- 8	90109-065G4	D- 7		B- 14	90340-12059	B- 12
3Y6-23183-00	C- 11	2J5-25394-01	D- 3	4SS-26256-00	D- 8	90109-06799	D- 13	90201-06071	B- 7	90387-0600F	C- 7
	C- 11	4XM-25394-00	D- 5	4SS-26259-00	D- 8	90109-081G1	D- 5		B- 11		C- 8
509-23184-L0	C- 11	4SS-25447-00	D- 5	4SS-26273-00	D- 8	90109-142F4	C- 10		C- 7		C- 8
5DH-23195-L0	C- 13	4SS-25448-00	D- 5	4SS-2628H-00	D- 8	90109-147F2	C- 9	90201-061A5	B- 8	90387-062W7	B- 11
	C- 14	4SS-25449-00	D- 5	4SS-26281-00	D- 8	90110-05201	C- 9	90201-06557	C- 7	90387-063F7	C- 4
4EW-2331E-L0	C- 14	4SS-25450-00	D- 5	4SS-26282-10	D- 8	90110-08096	C- 6	90201-08087	B- 2	90387-063G3	B- 11
5DH-23340-L0	C- 14	4SS-25451-00	D- 5	4SS-26287-01	D- 8	90116-08318	B- 2	90201-08089	D- 10	90387-0700G	B- 7
4SS-23346-L0	C- 14	4SS-25452-00	D- 5	4SS-26311-01	D- 8	90116-08388	B- 2	90201-083P5	B- 6	90387-0701A	C- 7
3SP-23356-L0	C- 14	5DH-25718-00	D- 7	4SS-2632G-00	D- 8	90116-08394	B- 2	90201-08326	D- 5	90387-085E1	B- 4
4SS-23364-L0	D- 15	5DH-2580T-00	D- 4	4JY-26335-00	D- 8	90119-06096	C- 7	90201-086F8	C- 6	90387-086N4	C- 6
4DA-23389-00	C- 12	5DH-2580T-10	D- 4	4SS-26372-00	D- 9	90119-06185	B- 11	90201-08730	C- 6	90387-08785	B- 3
5DH-2339E-00	C- 12	5DH-2580W-00	D- 7	4XM-27200-00	D- 10		C- 12	90201-08784	B- 6	90387-107T9	B- 4
5DH-23393-L0	C- 13	2VN-2582A-50	D- 11	4SS-27217-00	D- 10	90119-06214	C- 15	90201-10118	D- 9	90387-152F2	B- 4
	C- 14	4XM-2582T-00	D- 4	4SS-27218-00	D- 11	90122-06035	B- 8		D- 11	90387-164N2	C- 9
4EW-23416-00	C- 12	5DH-2582W-00	D- 7	3SP-27222-00	D- 11	90123-08090	D- 13	90201-10119	B- 15	90387-164N3	C- 9
4SS-23435-00	C- 12	5DH-25827-50	D- 7	3SP-27311-00	D- 10	90149-06011	C- 15		D- 10	90387-167Y9	C- 9
3SP-23441-00	C- 12	5DH-25828-50	D- 7	4XM-27411-00	D- 10		D- 12	90201-10591	D- 12	90387-1712R	C- 9
4DA-23485-20	C- 12	4SS-2583G-00	D- 9	4XM-27421-00	D- 10	90149-06272	D- 4	90201-112U6	C- 11	90387-1712Y	B- 12
4SS-24110-10	C- 15	3SP-2583V-00	D- 11	4GY-27491-00	D- 7	90151-04048	C- 9	90201-14740	C- 10	90387-2000B	D- 5
4EW-2412F-00	C- 15	4SS-25833-00	D- 9	56A-28166-00	C- 6	90151-06037	C- 2	90201-151A7	B- 4	90387-2000C	D- 5
24X-24144-00	C- 15	3XP-25852-50	D- 11	4SS-82310-00	D- 14		C- 3	90201-152H7	B- 14	90387-202A0	C- 3
3SP-24173-00	C- 15	4SS-25852-00	D- 9	4PE-82370-00	D- 14	90152-06010	B- 14	90201-15700	C- 2	90387-202T9	B- 15
4SS-24181-00	C- 15	2VN-25854-00	D- 11	5DH-82509-00	D- 14	90159-06016	B- 15	90201-164H4	C- 9	90387-227H7	D- 8
4SS-24182-00	C- 15	4SS-25854-00	D- 9	38V-82911-00	D- 13	90159-06078	C- 4		C- 10	90401-10168	D- 9
3JD-24186-00	C- 15	2VN-25855-00	D- 11	38V-82913-00	D- 13		C- 8	90201-171G4	B- 14		D- 11
5DH-24240-00	C- 15	2VN-25866-00	D- 11	4GY-83912-00	D- 13		C- 8	90201-20611	B- 15	90430-06014	B- 6
3XJ-24380-00	C- 15	3YX-25866-10	D- 9	4SS-83913-00	D- 9	90159-06182	C- 8		B- 15		B- 13
3JD-24500-01	C- 15	4SS-25866-00	D- 9	4SS-83922-01	D- 9		C- 8		C- 2		B- 15
4X8-24512-00	C- 15	3YK-25867-00	D- 9	23X-83976-00	D- 13	90170-16326	B- 15	90201-22555	C- 2	90430-12227	B- 12
3AJ-24534-00	C- 15	4SS-25868-00	D- 9	4XM-85540-00	D- 14	90170-24373	C- 12	90201-247L2	C- 12	90445-08605	B- 12
1UY-24610-00	C- 15	5DH-25872-00	D- 9	4SS-85546-01	D- 14	90176-08026	B- 2	90201-286K9	C- 12	90445-09104	C- 15
4SS-24728-00	D- 2	5DH-25873-00	D- 11	4SS-85550-00	D- 12	90179-06568	C- 9	90202-05193	C- 15	90445-09220	C- 15
5DH-24731-00	D- 2	5DH-25875-00	D- 4	4SS-85560-00	D- 12	90179-08299	B- 2	90209-06096	B- 8	90445-114J7	C- 15
5DH-24770-00	D- 2	2VM-25876-00	D- 11	90101-06664	C- 5	90179-08401	D- 13	90209-18135	C- 2	90445-137H9	D- 11
4DA-25104-00	D- 3	4SS-25880-00	D- 9	90101-08777	D- 6	90179-16226	C- 3	90209-18208	C- 2	90450-22017	B- 7
4SS-25111-00	D- 3	4SS-25889-00	D- 9	90105-05361	C- 12	90179-16672	D- 3	90209-22071	B- 5	90450-25037	B- 7
5DH-25117-00	D- 3	4SS-2589F-00	D- 9	90105-06553	B- 8	90179-28650	C- 12	90209-22248	E- 2	90450-28014	B- 7
4SS-25181-00	D- 3	4EW-25894-00	D- 11		C- 4	90183-06023	B- 8	90215-16289	B- 15	90450-51070	B- 8
5DH-25183-00	D- 3	5DH-25916-00	D- 4	90105-06556	B- 12		C- 7	90215-20261	C- 3	90450-70072	B- 8
5DH-25186-00	D- 3		D- 7	90105-08099	C- 6	90183-06069	C- 8	90240-08120	D- 10	90460-15126	D- 14

NUMERICAL INDEX

PART NO.	GRID NO.	PART NO.	GRID NO.	PART NO.	GRID NO.	PART NO.	GRID NO.	PART NO.	GRID NO.	PART NO.	GRID NO.
90461-10136	B- 12	92907-06100	D- 2	93332-00081	C- 12	95027-06012	D- 7	97801-03008	C- 15		
90464-13073	D- 14	92907-06600	B- 13	93340-21008	B- 15			98507-03008	B- 8		
90464-13077	D- 13	92907-08200	D- 4	93340-21505	B- 4	95027-06016	C- 15	98507-04008	B- 9		
90464-50255	D- 14	92907-18600	D- 6	93342-22215	C- 9			98507-04012	B- 9		
90465-13275	C- 15	93102-12106	B- 6	93410-22039	C- 2	95027-06020	B- 8	98507-05012	B- 4		
	D- 14	93102-12224	B- 15		C- 2		C- 5	98507-06016	B- 13		
90465-16258	D- 9	93102-17263	B- 14	93440-15012	B- 14		C- 7	98507-06030	B- 13		
90467-09006	B- 7	93102-22363	B- 5		C- 2	95027-06025	B- 11	98706-04012	D- 9		
90467-10008	C- 15	93102-26042	C- 2	93450-16068	B- 5		B- 13	98707-06025	C- 15		
90467-12053	D- 11	93102-26468	D- 3		E- 2		D- 8	98907-05010	B- 2		
90467-13062	B- 2	93103-32183	B- 5	93507-32009	B- 14	95027-06030	B- 6	98907-05016	B- 3		
90467-21068	B- 7	93104-08040	B- 2	93521-64032	B- 4		B- 7	98907-06020	C- 15		
90468-16191	D- 10		B- 4	93603-14240	B- 4		B- 13	99001-06600	B- 6		
90468-26048	B- 14	93106-22019	C- 9	93604-10011	B- 6		C- 7	99009-10400	B- 15		
90480-08608	D- 5	93106-28023	D- 5		B- 13	95027-06040	B- 13	99241-00080	C- 7		
90480-15528	B- 7	93109-11073	B- 6	93604-18251	B- 2	95027-06045	B- 11		C- 7		
90480-16561	B- 11	93109-12012	C- 5	93612-16254	B- 12	95027-06050	C- 9	99244-00200	C- 10		
90480-18549	C- 15	93109-20029	C- 9	9383A-12017	C- 3	95027-06065	B- 6	99530-10114	B- 2		
90501-05265	C- 5		C- 10	9383A-13031	C- 3	95027-08020	D- 4		B- 13		
90501-12081	B- 14	93210-11073	D- 10	9383A-14054	C- 3	95027-08035	C- 12	99590-17016	B- 12		
90501-23598	B- 15	93210-15171	B- 14	94108-2110Y	D- 3	95027-08040	C- 6				
90501-30742	B- 4	93210-15620	D- 11	94108-2112Y	D- 3		C- 12				
90506-16500	D- 10	93210-16314	B- 12	94108-217X2	D- 3	95027-08065	C- 6				
90507-20052	B- 11	93210-19123	B- 13	94110-1900X	D- 5	95317-10600	D- 12				
90508-14184	B- 15	93210-42728	B- 11	94110-1911A	D- 5	95606-06100	D- 9				
90508-16183	B- 3	93210-63442	B- 2	94110-1913B	D- 5	95607-05100	B- 8				
90508-26187	C- 4	93210-90785	B- 2	94209-21229	D- 3	95607-06100	D- 13				
90508-26450	B- 14	93300-60801	B- 4	94210-19222	D- 5	95617-08200	C- 6				
90508-28288	D- 10	93300-60804	C- 6	94210-19224	D- 5		D- 5				
90508-28289	D- 10	93306-00105	B- 6	94227-21101	D- 3	95617-10200	C- 6				
90508-295A7	C- 5	93306-00418	D- 5	94307-21145	D- 3		C- 6				
90560-08213	B- 4	93306-20431	C- 2	94316-19156	D- 5		C- 11				
90560-12280	C- 5	93306-30411	C- 2	94321-19135	D- 5	95707-08500	C- 6				
90560-17279	B- 14	93306-37204	B- 5	94330-21084	D- 3		D- 6				
91A20-05065	B- 7	93306-90403	D- 3	94416-21509	D- 3	95817-08050	C- 6				
91317-04006	B- 4	93306-90504	C- 4	94418-19537	D- 5	95817-10090	C- 6				
91317-04008	B- 2	93310-225N0	B- 15	94561-60111	D- 6	95827-06012	D- 4				
91317-06014	D- 9	93310-315S4	B- 5	94581-68112	D- 6	95827-06016	C- 8				
91317-06016	D- 14		E- 2	94661-55001	D- 6		C- 8				
91317-06045	B- 12	93310-522P7	B- 5	94681-68001	D- 6		C- 8				
91317-06055	B- 12		E- 2	94702-00324	B- 2		C- 8				
91317-06070	B- 12	93311-31515	C- 3	94709-00324	B- 2	97007-05012	B- 4				
91401-20012	D- 10	93311-41530	C- 2	95021-08040	C- 14	97007-05016	B- 3				
91401-25015	D- 10	93315-11206	B- 15	95027-06010	B- 6		D- 13				
92014-06016	D- 11	93315-32056	C- 9		B- 13	97007-06012	D- 2				
92017-06010	B- 11		C- 10		C- 9	97027-06012	B- 14				
92907-03100	B- 8	93317-22262	C- 9	95027-06012	B- 11	97707-60016	C- 7				
92907-05600	B- 3	93332-00068	C- 12		C- 7	97780-50510	D- 11				

*COPYRIGHT: All rights reserved. No part of this publication
may be reproduced without permission.*

YAMAHA

YAMAHA MOTOR CO., LTD.
2500 SHINGAI IWATA SHIZUOKA JAPAN
SERVICE INFORMATION DIV.

PRINTED ON RECYCLED PAPER

Printed in Japan
First edition JUL., 1997