



PARTS CATALOGUE

YZ125S (5XE1) U.S.A., CANADA, S.AFRICA

YZ125 (5XE2) EUROPE

YZ125 (5XE3) JAPAN

YZ125S (5XE4) AUSTRALIA, NEW ZEALAND

YZ125S/YZ125
PARTS CATALOGUE
©2003 by Yamaha Motor Co., Ltd.
1st edition, June 2003
All rights reserved.
Any reprinting or unauthorized use
without the written permission of
Yamaha Motor Co., Ltd.
is expressly prohibited.
Printed in Japan.

A3



A4

FOREWORD

This Parts Catalogue is related to the parts for the model(s) on the cover page. When you are ordering replacement parts, please refer to this Parts Catalogue and quote both part numbers and part names correctly.

1. Modifications or additions which have been made after the issue of the Parts Catalogue will be announced in the Parts News.

It is advisable that you make the necessary corrections to the Parts Catalogue according to the Parts News.

2. Abbreviations

The following abbreviations are used in this Parts Catalogue.

“UR” Use specified parts number.

“UN” Use as many as needed.

“AP” Alternate Parts

“LM” Locally Made (Parts need to be ordered locally)

“F#” Frame No. (Applicable machine No.)

“O/S” Over Size

3. The number of components for assembly

- Parts, which are to be supplied in an assembly, are listed with a dot (.) in front of the part name as shown below.
- The numeral appearing to the right of each component part indicates the quantity of parts for each assembly unit.

PART NO.	DESCRIPTION	Q'TY	REMARKS
2F5-83310-60	FRONT FLASHER LIGHT ASSY	2	
115-83311-60	.BULB (6V-18W)	1	

4. Applicable colours of graphics are represented in the “REMARKS” as shown below.

PART NO.	DESCRIPTION	Q'TY	REMARKS
2N4-24110-00-X5	FUEL TANK COMP.	2	MXR
3J1-24240-10	.GRAPHIC, FUEL TANK	1	FOR MXR

5. Note that the illustrations for reference in finding parts numbers are not to be used for assembling. When assembling, please use the applicable service manual.

6. The asterisk (*) before a reference number indicates modified items after the first edition.

FOREWORD

7. Applicable Serial No.

Engine Serial No.

Frame Serial No.

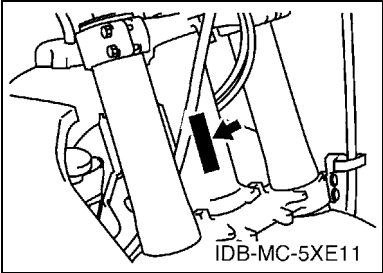
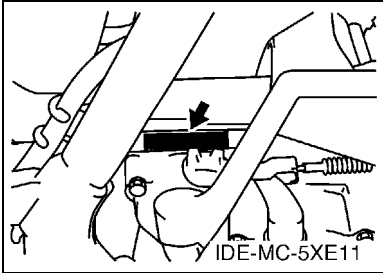

8. Applicable Colour Code (The (*) mark shows Model colour.)

Abbreviation	Colour Name	Colour Code
DPBSE(*)	DEEP PURPLISH BLUE SOLID E	0583

MODEL LABEL

(1) A label called "Model Label" is affixed in the location as indicated in (3) below. When using this parts catalogue, please be sure to cross-reference the "model code - production code No." in the catalogue with the "model code - production code No." indicated on the Model Label affixed onto the product concerned.

(2) "Model Label" Indication

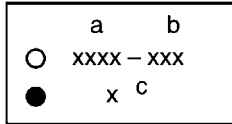

a: Model Type Code
b: Production Code No.
c: Colouring Type

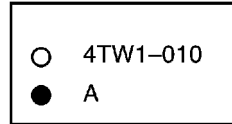

(3) Model Label Affixing Location

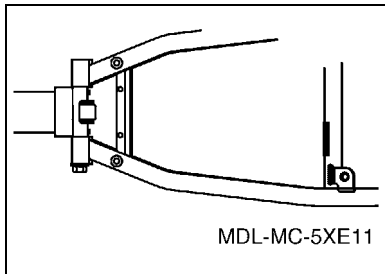

(4) Colouring Information

Model Code	Colouring Type Code	Colour Code	Colour Name	Abbreviation
5XE1	A	0583	DEEP PURPLISH BLUE SOLID E	DPBSE
5XE2	A	0583	DEEP PURPLISH BLUE SOLID E	DPBSE
5XE3	A	0583	DEEP PURPLISH BLUE SOLID E	DPBSE
5XE4	A	0583	DEEP PURPLISH BLUE SOLID E	DPBSE

(5) Model Code - Production Code Number of Model Listed in This Parts Catalogue

Model Code	Production Code No.	Country (destination)	Model Code	Production Code No.	Country (destination)
5XE1	010	U.S.A.			
	020	CANADA			
	030	SOUTH AFRICA			
5XE2	010	FRANCE			
	020	GERMANY			
	030	SPAIN			
	040	UNITED KINGDOM			
	050	ITALY			
5XE3	010	JAPAN			
5XE4	010	AUSTRALIA			
		NEW ZEALAND			

CONTENTS

ENGINE

CYLINDER HEAD	B2
GOVERNOR	B4
CRANKSHAFT & PISTON	B5
WATER PUMP	B6
RADIATOR & HOSE	B7
INTAKE	B8
CARBURETOR	B9
EXHAUST	B12
CRANKCASE	B13
CRANKCASE COVER 1	B14
STARTER	B15
CLUTCH	C2
TRANSMISSION	C3
SHIFT CAM & FORK	C5
SHIFT SHAFT	C6

CHASSIS

FRAME	C7
FENDER	C8
SIDE COVER	C9
REAR ARM	C10
REAR SUSPENSION	C12
STEERING	C14
FRONT FORK	C15
FUEL TANK	D4
SEAT	D5
FRONT WHEEL	D6
FRONT BRAKE CALIPER	D7
REAR WHEEL	D8
REAR BRAKE CALIPER	D10
STEERING HANDLE & CABLE	D11
FRONT MASTER CYLINDER	D12
STAND & FOOTREST	D13
REAR MASTER CYLINDER	D14
GENERATOR	D15
HANDLE SWITCH & LEVER	E2
ELECTRICAL 1	E3
ALTERNATE FOR CHASSIS	E4
OPTIONAL PARTS 1	E6

INDEX

NUMERICAL INDEX	M1
-----------------------	----

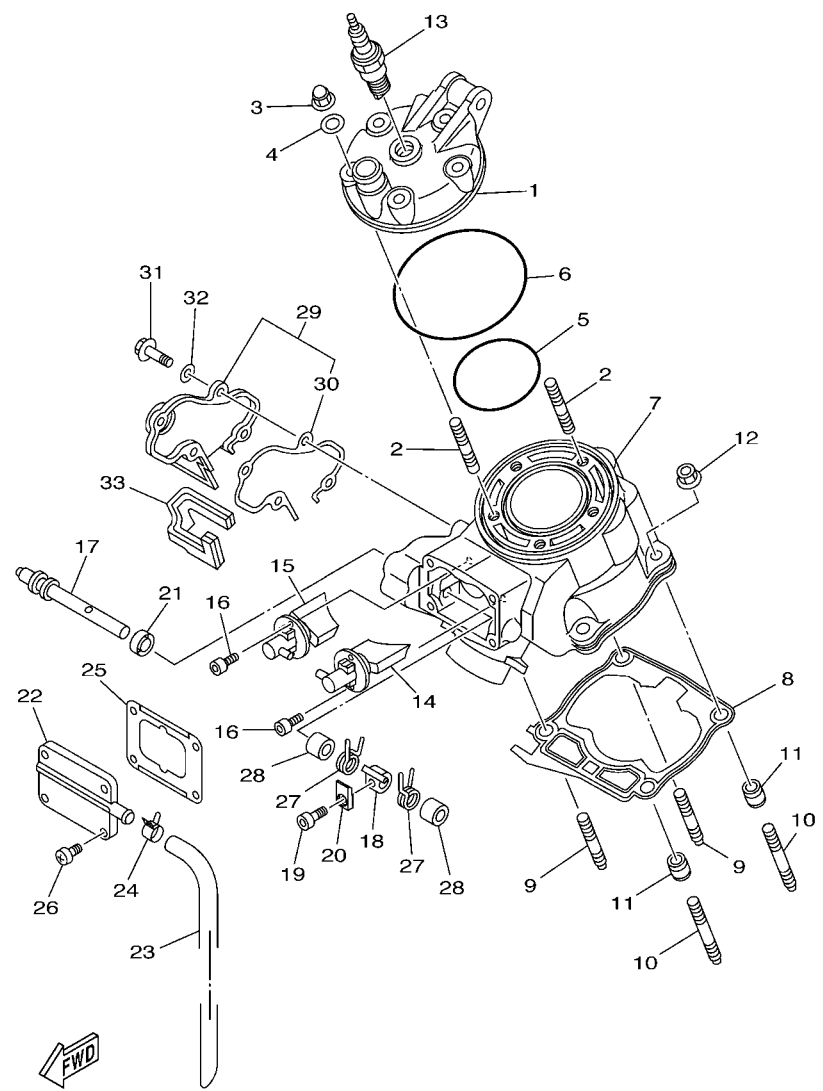

5UN1100-B010

FIG. 1 CYLINDER HEAD

REF. NO.	PART NO.	DESCRIPTION	5XE1	5XE2	5XE3	5XE4	REMARKS
1	5UN-11111-00	HEAD, CYLINDER 1	1	1	1	1	
2	90116-08394	BOLT, STUD	5	5	5	5	
3	90176-08026	NUT, CROWN	5	5	5	5	
4	90201-080L8	WASHER, PLATE	5	5	5	5	
5	93210-63442	O-RING	1	1	1	1	
6	93210-90785	O-RING	1	1	1	1	
7	5XE-11311-00	CYLINDER 1	1	1	1	1	
8	5DH-11351-01	GASKET, CYLINDER	1	1	1	1	
9	90116-08318	BOLT, STUD	2	2	2	2	
10	90116-08388	BOLT, STUD	2	2	2	2	
11	99590-10114	PIN, DOWEL	2	2	2	2	
12	90179-08299	NUT	4	4	4	4	
13	94702-00324	PLUG, SPARK (NGK BR9EG)	1	1		1	
	94709-00324	PLUG, SPARK (NGK BR9EG)			1		
14	5HD-1131D-20	VALVE ASSY	1	1	1	1	
15	5HD-1132D-20	VALVE ASSY 2	1	1	1	1	
16	91317-05012	BOLT	4	4	4	4	
17	5HD-1131V-00	SHAFT 1	1	1	1	1	
18	4SS-11832-00	LEVER, LINK	1	1	1	1	
19	91317-04010	BOLT	1	1	1	1	
20	5UN-11395-00	HOLDER	1	1	1	1	
21	93104-08040	OIL SEAL	1	1	1	1	
22	4SS-1131M-00	COVER	1	1	1	1	
23	4JY-11166-00	PIPE, BREATHER 1	1	1	1	1	
24	90467-13062	CLIP	1	1	1	1	
25	4JY-11354-10	GASKET	1	1	1	1	
26	98907-05016	SCREW, BIND	4	4	4	4	

FIG. 2 GOVERNOR

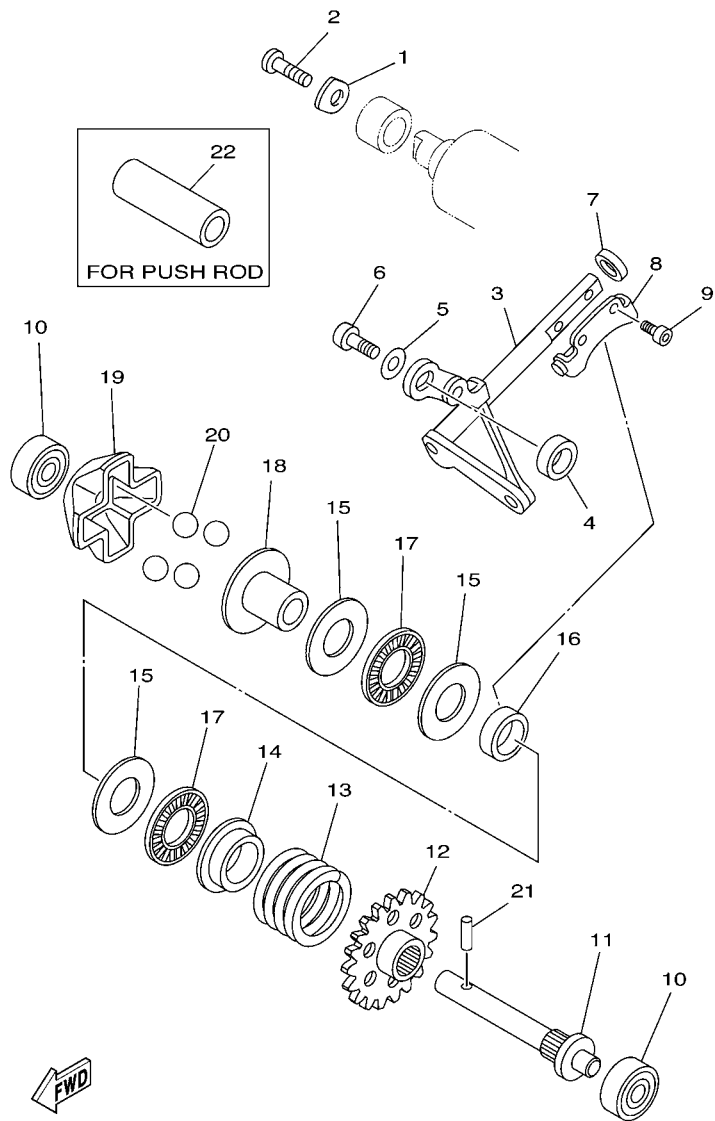

5NY1100-A020

REF. NO.	PART NO.	DESCRIPTION	5XE1	5XE2	5XE3	5XE4	REMARKS
1	4JY-11915-01	PLATE, THRUST 1	1	1	1	1	
2	98507-05012	SCREW, PAN HEAD	1	1	1	1	
3	4SS-11990-00	PUSH ROD ASSY	1	1	1	1	
4	90387-085E1	COLLAR	1	1	1	1	
5	90201-057H5	WASHER, PLATE	1	1	1	1	
6	97007-05012	BOLT	1	1	1	1	
7	93104-08040	OIL SEAL	1	1	1	1	
8	3JE-11922-01	FORK, GOVERNOR	1	1	1	1	
9	91317-04006	BOLT	2	2	2	2	
10	93300-60801	BEARING (B0060)	2	2	2	2	KOYO
11	5X4-11921-02	SHAFT, GOVERNOR	1	1	1	1	
12	5NY-11953-00	GEAR, GOVERNOR	1	1	1	1	
13	90501-30001	SPRING, COMPRESSION	1	1	1	1	
14	5CU-11952-00	PLATE	1	1	1	1	
15	90201-150U6	WASHER, PLATE	3	3	3	3	
16	90387-152F2	COLLAR	1	1	1	1	
17	93340-21505	BEARING	2	2	2	2	
18	5CU-11912-00	RETAINER, WEIGHT	1	1	1	1	
19	5CU-11911-00	RETAINER	1	1	1	1	
20	93507-16020	BALL	4	4	4	4	
21	93603-14240	PIN, DOWEL	1	1	1	1	
22	90387-107T9	COLLAR	1	1	1	1	AP

FIG. 3 CRANKSHAFT & PISTON

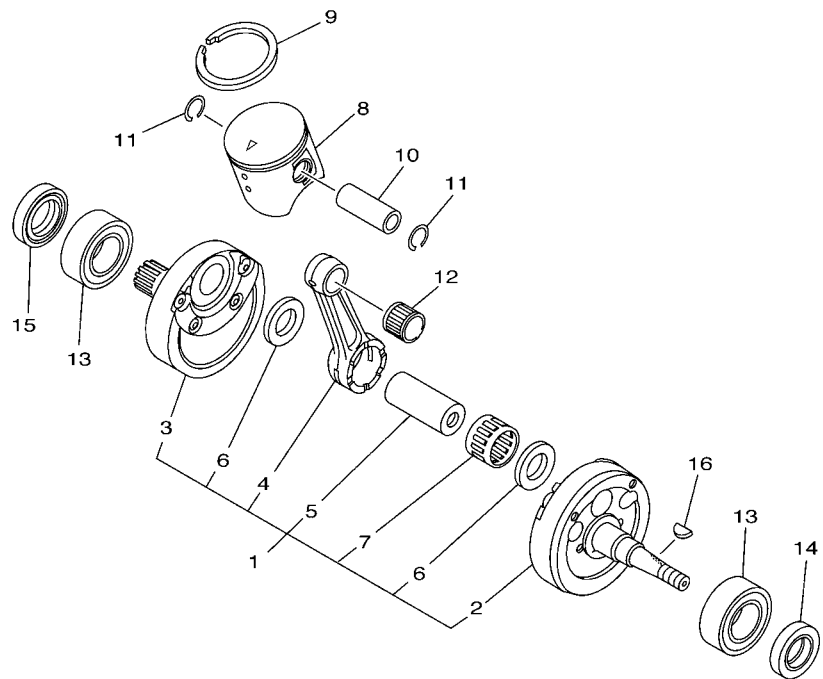

5NY1100-A030

REF. NO.	PART NO.	DESCRIPTION	5XE1	5XE2	5XE3	5XE4	REMARKS
1	5MV-11400-00	CRANKSHAFT ASSY	1	1	1	1	
2	5MV-11410-00	.CRANKSHAFT	1	1	1	1	
3	5MV-11420-00	.CRANKSHAFT	1	1	1	1	
4	5MV-11651-00	.ROD, CONNECTING	1	1	1	1	
5	3JD-11681-10	.PIN, CRANK 1	1	1	1	1	
6	90209-22071	.WASHER	2	2	2	2	
7	93310-522P7	.BEARING	1	1	1	1	
8	5NY-11631-01-A0	PISTON (STD)	1	1	1	1	UR RED
	5NY-11631-01-B0	PISTON (STD)	1	1	1	1	UR ORANGE
	5NY-11631-01-C0	PISTON (STD)	1	1	1	1	UR GREEN
	5NY-11631-01-D0	PISTON (STD)	1	1	1	1	UR PURPLE
9	5NY-11611-00	RING, PISTON	1	1	1	1	
10	5UN-11633-00	PIN, PISTON	1	1	1	1	
11	93450-16068	CIRCLIP	2	2	2	2	
12	93310-21510	BEARING	1	1	1	1	
13	93306-37204	BEARING (63/22SH2-9TC4)	2	2	2	2	KOYO
14	93102-20485	OIL SEAL	1	1	1	1	
15	93102-30008	OIL SEAL	1	1	1	1	
16	90280-03017	KEY, WOODRUFF	1	1	1	1	

FIG. 4 WATER PUMP

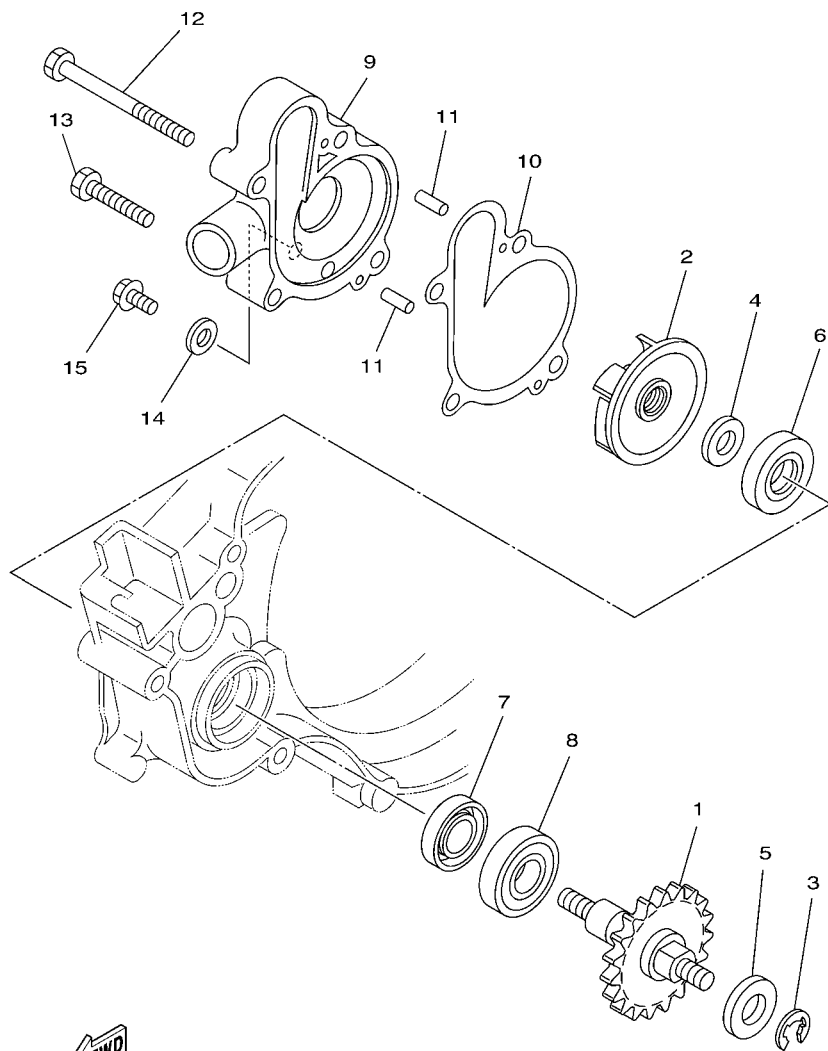

5DH1100-8040

REF. NO.	PART NO.	DESCRIPTION	5XE1	5XE2	5XE3	5XE4	REMARKS
1	5DH-12459-01	GEAR, IMPELLER SHAFT	1	1	1	1	
2	5DH-12451-00	IMPELLER, WATER PUMP	1	1	1	1	
3	99001-06600	CIRCLIP	1	1	1	1	
4	90201-083P5	WASHER, PLATE	1	1	1	1	
5	90201-08784	WASHER, PLATE	1	1	1	1	
6	93109-11073	OIL SEAL	1	1	1	1	
7	93102-12106	OIL SEAL (SD 12-22-5 HS)	1	1	1	1	
8	93306-00105	BEARING (B6001)	1	1	1	1	
9	4JY-12422-01	COVER, HOUSING	1	1	1	1	
10	4JY-12428-10	GASKET, HOUSING COVER 2	1	1	1	1	
11	93604-10011	PIN, DOWEL	2	2	2	2	
12	95027-06065	BOLT, FLANGE	2	2	2	2	
13	95027-06030	BOLT, FLANGE	2	2	2	2	
14	90430-06014	GASKET	1	1	1	1	
15	95027-06010	BOLT, FLANGE	1	1	1	1	

FIG. 5 RADIATOR & HOSE

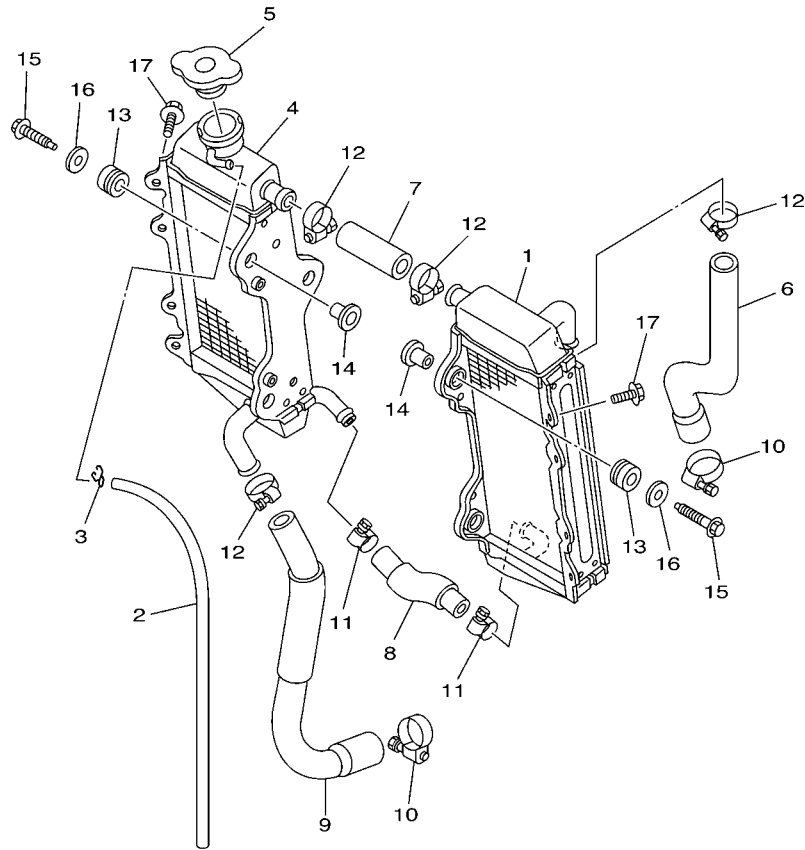

REF. NO.	PART NO.	DESCRIPTION	5XE1	5XE2	5XE3	5XE4	REMARKS
1	5NY-1240A-00	RADIATOR ASSY	1	1	1	1	
2	91A20-05065	TUBE, FLEXIBLE VINYL	1	1	1	1	
3	90467-09006	CLIP	1	1	1	1	
4	5NY-12461-00	RADIATOR ASSY	1	1	1	1	
5	5HD-12462-00	CAP, RADIATOR	1	1	1	1	
6	5NY-12481-00	PIPE 1	1	1	1	1	
7	5NY-12482-00	PIPE 2	1	1	1	1	
8	5NY-12483-01	PIPE 3	1	1	1	1	
9	5NY-12484-00	PIPE 4	1	1	1	1	
10	90450-28014	HOSE CLAMP ASSY	2	2	2	2	
11	90450-22017	HOSE CLAMP ASSY	2	2	2	2	
12	90450-25037	HOSE CLAMP ASSY	4	4	4	4	
13	90480-15528	GROMMET	6	6	6	6	
14	90387-06065	COLLAR	6	6	6	6	
15	95027-06025	BOLT, FLANGE	6	6	6	6	
16	90201-06571	WASHER, PLATE	6	6	6	6	
17	95827-06010	BOLT, FLANGE	2	2	2	2	



5XE1100-C050

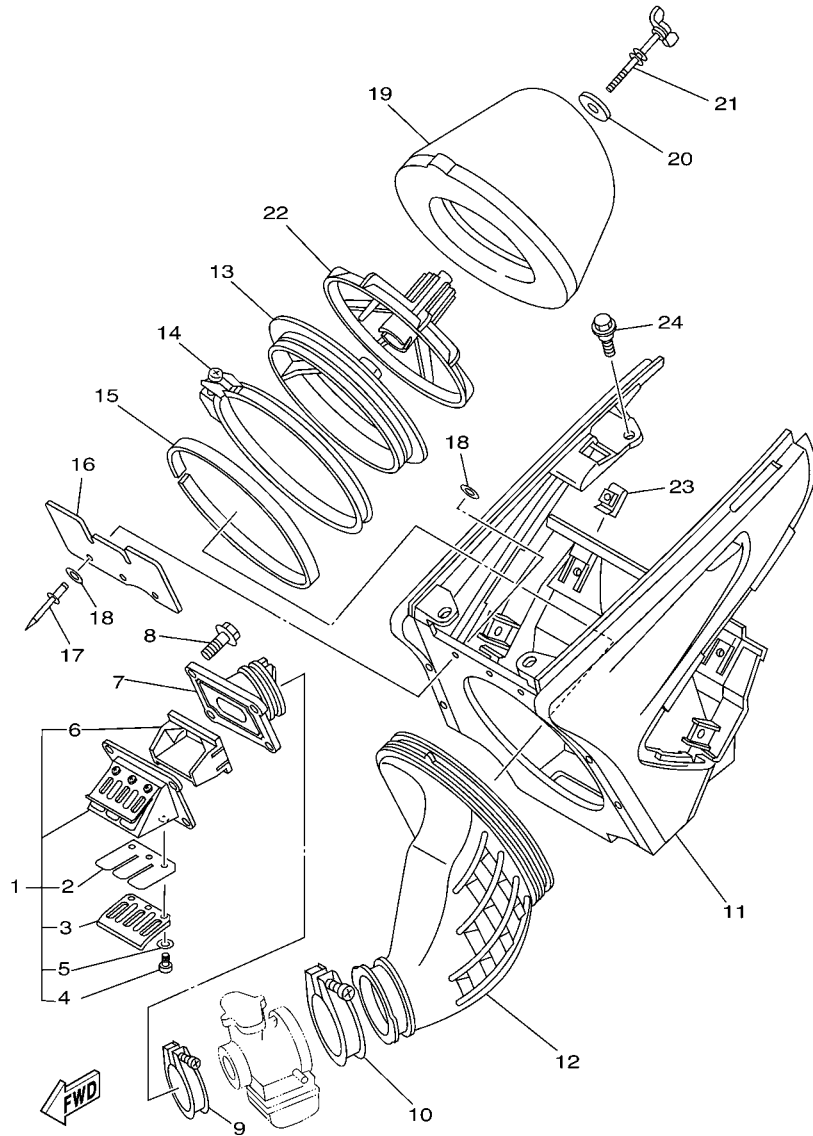
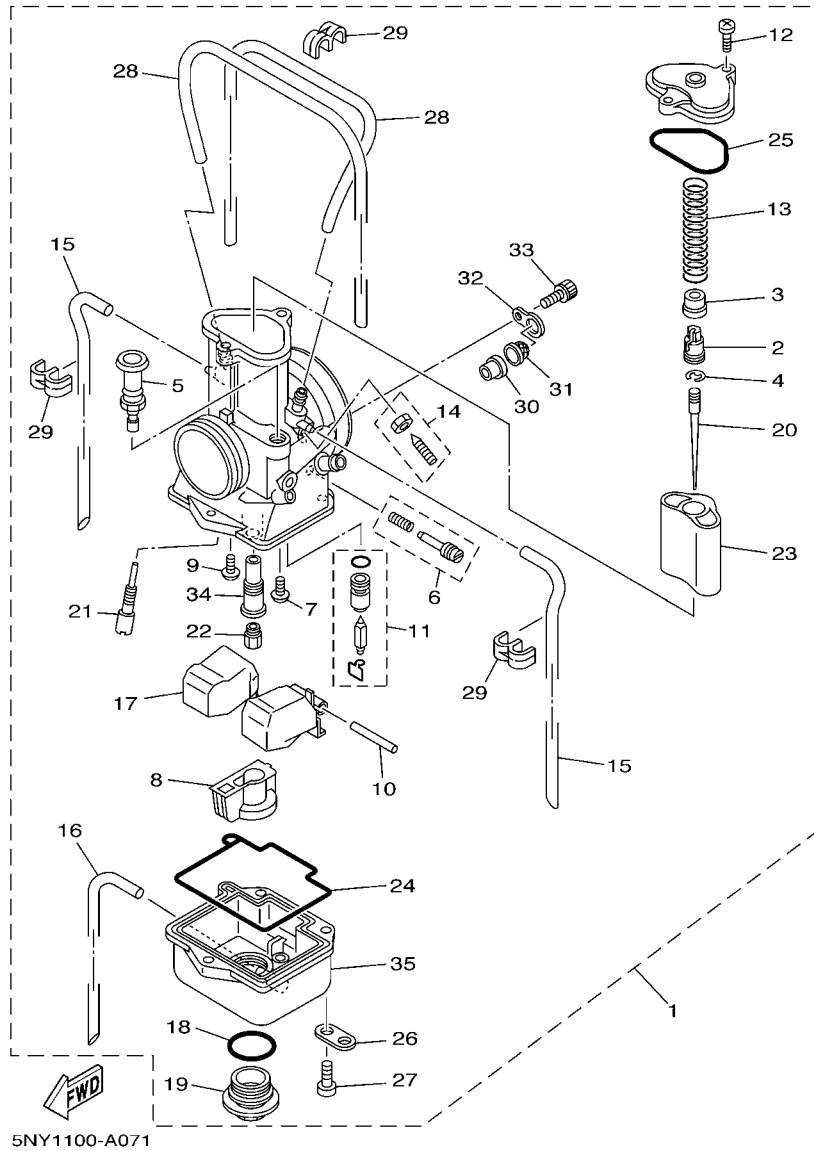

FIG. 6 INTAKE

REF. NO.	PART NO.	DESCRIPTION	5XE1	5XE2	5XE3	5XE4	REMARKS
1	5UN-13610-00	REED VALVE ASSY	1	1	1	1	
2	5UN-13613-00	.REED, VALVE	2	2	2	2	
3	5MV-13616-00	.STOPPER, REED VALVE	2	2	2	2	
4	98507-03006	.SCREW, PAN HEAD	6	6	6	6	
5	92907-03100	.WASHER, SPRING	6	6	6	6	
6	5MV-13625-00	.SPACER, REED VALVE	1	1	1	1	
7	5UN-13565-00	JOINT, CARBURETOR	1	1	1	1	
8	95027-06020	BOLT, FLANGE	4	4	4	4	
9	90450-54003	HOSE CLAMP ASSY	1	1	1	1	
10	90450-70072	HOSE CLAMP ASSY	1	1	1	1	
11	5NY-14401-01	AIR CLEANER CASE ASSY	1	1	1	1	
12	5NX-14453-00	JOINT, AIR CLEANER 1	1	1	1	1	
13	5NY-14459-00	HOLDER, GUIDE	1	1	1	1	
14	5NY-14455-10	BAND	1	1	1	1	
15	5NY-14442-00	SPACER	1	1	1	1	
16	5NY-14417-00	COVER 1	1	1	1	1	
17	90267-32070	RIVET, BLIND	3	3	3	3	
18	90201-03313	WASHER, PLATE	6	6	6	6	
19	4XM-14451-00	ELEMENT, AIR CLEANER	1	1	1	1	
20	90209-06096	WASHER	1	1	1	1	
21	90122-06035	BOLT, WING	1	1	1	1	
22	3JD-14458-01	GUIDE	1	1	1	1	
23	90183-06023	NUT, SPRING	4	4	4	4	
24	90109-067F4	BOLT	4	4	4	4	

FIG. 7 CARBURETOR



REF. NO.	PART NO.	DESCRIPTION	5XE1	5XE2	5XE3	5XE4	REMARKS
1	5XE-14101-00	CARBURETOR ASSY 1	1		1	1	
	5XE-14101-10	CARBURETOR ASSY 1		1			
2	5HD-14261-00	.HOLDER	1	1	1	1	
3	4PE-14194-00	.RING	1	1	1	1	
4	3MA-14159-00	.CLIP	1	1	1	1	
5	3JE-14171-00	.PLUNGER, STARTER	1	1	1	1	
6	3JD-14104-00	.AIR SCREW SET	1	1	1	1	
7	1FN-14565-00	.SCREW	1	1	1	1	
8	5ET-14261-01	.HOLDER	1	1	1	1	
9	98507-04008	.SCREW, PAN HEAD	1	1	1	1	
10	353-14186-00	.PIN, FLOAT	1	1	1	1	
11	4PE-14107-38	.NEEDLE VALVE SET	1	1	1	1	
12	98507-04014	.SCREW, PAN HEAD	2	2	2	2	
13	4PE-14131-00	.SPRING, THROTTLE VALVE	1	1	1	1	
14	4PE-14103-00	.THROTTLE SCREW SET	1	1	1	1	
15	5ET-14197-00	.PIPE	2	2	2	2	
16	10V-14196-00	.PIPE	1	1	1	1	
17	5ET-14185-00	.FLOAT	1	1	1	1	
18	2K6-14147-00	.O-RING	1	1	1	1	
19	5ET-14115-00	.PLUG, SCREW	1	1	1	1	
20	284-14116-F6	.NEEDLE (6CHY6-81)	1		1	1	STD
	284-14116-F5	.NEEDLE (6CHY6-80)		1			STD
	284-14116-E3	.NEEDLE (6CHY5-78)	1	1	1	1	AP
	284-14116-E4	.NEEDLE (6CHY5-79)	1	1	1	1	AP
	284-14116-E5	.NEEDLE (6CHY5-80)	1	1	1	1	AP
	284-14116-E6	.NEEDLE (6CHY5-81)	1	1	1	1	AP
	284-14116-E7	.NEEDLE (6CHY5-82)	1	1	1	1	AP

FIG. 7 CARBURETOR

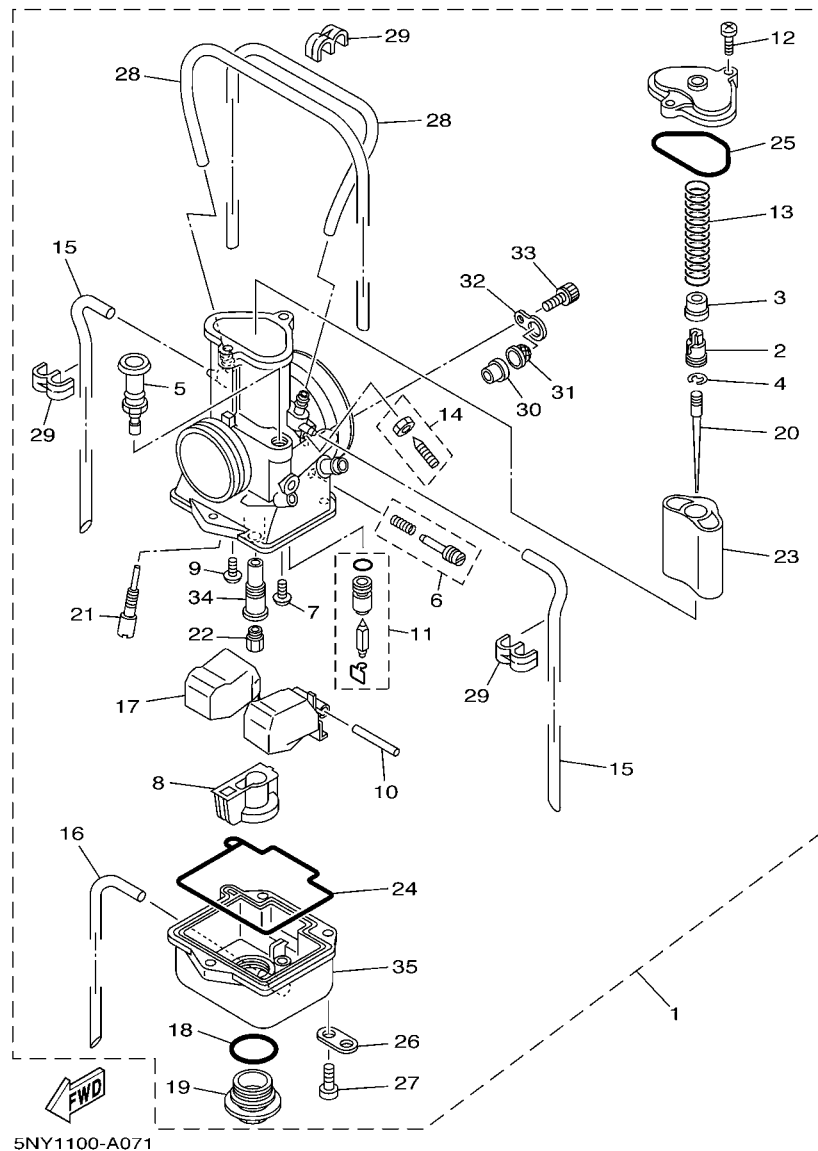

REF. NO.	PART NO.	DESCRIPTION	5XET	5XE2	5XE3	5XE4	REMARKS
20	284-14116-E8	.NEEDLE (6CHY5-83)	1	1	1	1	AP
	284-14116-E9	.NEEDLE (6CHY5-84)	1	1	1	1	AP
	284-14116-F5	.NEEDLE (6CHY6-80)	1		1	1	AP
	284-14116-F3	.NEEDLE (6CHY6-78)	1	1	1	1	AP
	284-14116-F4	.NEEDLE (6CHY6-79)	1	1	1	1	AP
	284-14116-F6	.NEEDLE (6CHY6-81)		1			AP
	284-14116-F7	.NEEDLE (6CHY6-82)	1	1	1	1	AP
	284-14116-F8	.NEEDLE (6CHY6-83)	1	1	1	1	AP
	284-14116-F9	.NEEDLE (6CHY6-84)	1	1	1	1	AP
21	4KM-14142-40	.JET, PILOT (# 40)		1	1	1	STD
	4KM-14142-37	.JET, PILOT (# 37.5)		1			STD
	4KM-14142-30	.JET, PILOT (# 30)	1	1	1	1	AP
	4KM-14142-32	.JET, PILOT (# 32.5)	1	1	1	1	AP
	4KM-14142-35	.JET, PILOT (# 35)	1	1	1	1	AP
	4KM-14142-37	.JET, PILOT (# 37.5)	1		1	1	AP
	4KM-14142-40	.JET, PILOT (# 40)		1			AP
	4KM-14142-42	.JET, PILOT (# 42.5)	1	1	1	1	AP
	4KM-14142-45	.JET, PILOT (# 45)	1	1	1	1	AP
	4KM-14142-47	.JET, PILOT (# 47.5)	1	1	1	1	AP
	4KM-14142-50	.JET, PILOT (# 50)	1	1	1	1	AP
22	137-14143-82	.JET, MAIN (#410)	1	1	1	1	STD
	137-14143-78	.JET, MAIN (#390)	1	1	1	1	AP
	137-14143-80	.JET, MAIN (#400)	1	1	1	1	AP
	137-14143-84	.JET, MAIN (#420)	1	1	1	1	AP
	137-14143-86	.JET, MAIN (#430)	1	1	1	1	AP
	137-14143-88	.JET, MAIN (#440)	1	1	1	1	AP
	137-14143-90	.JET, MAIN (#450)	1	1	1	1	AP

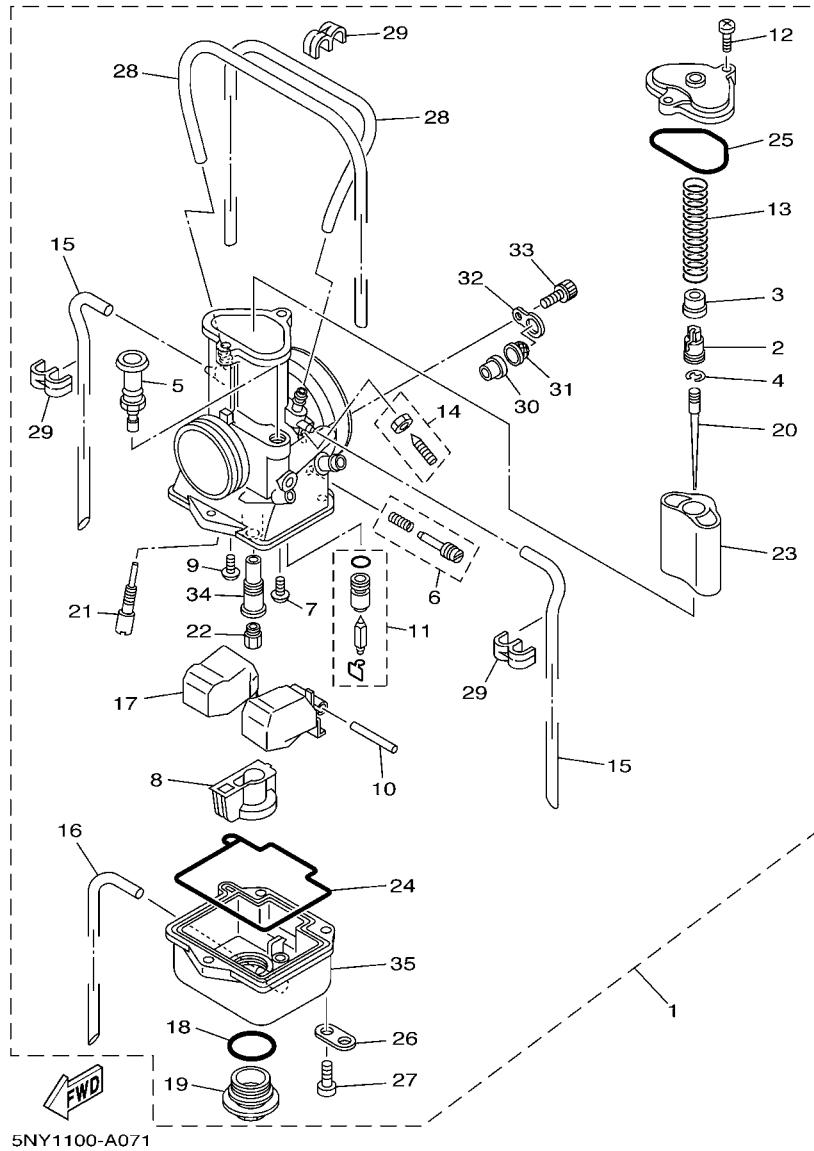
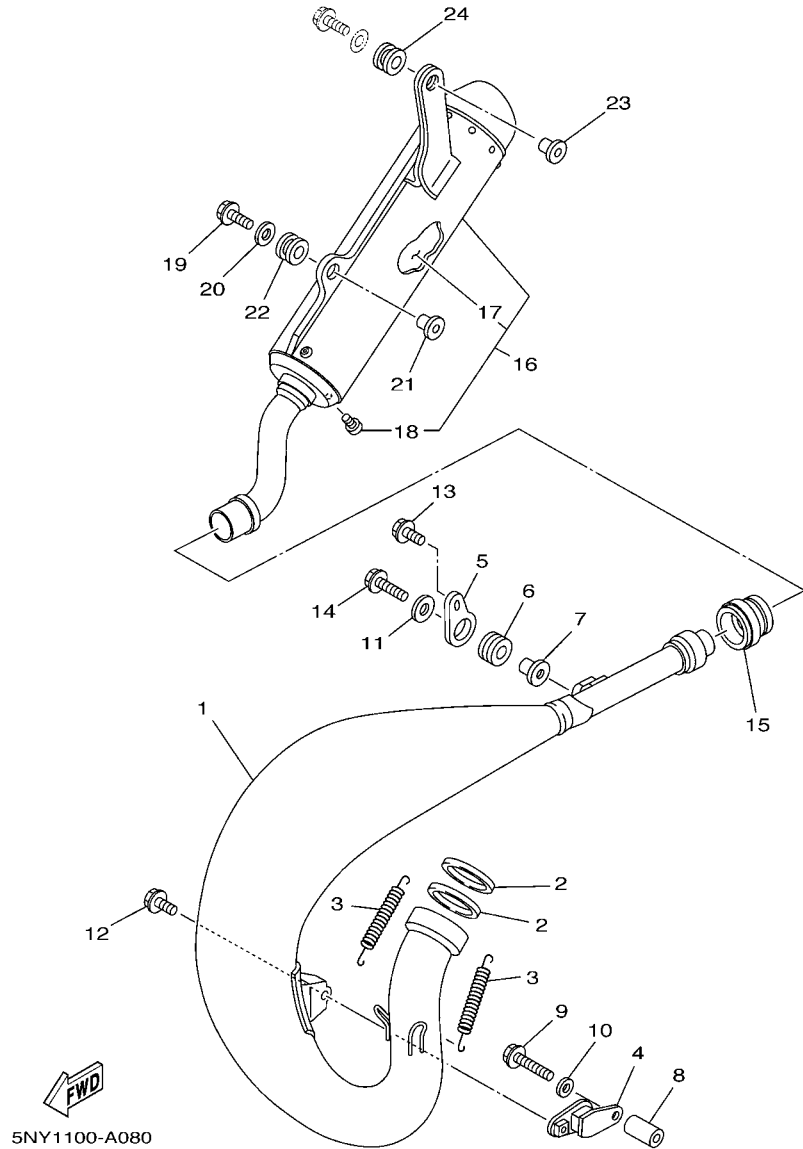

FIG. 7 CARBURETOR

REF. NO.	PART NO.	DESCRIPTION	5XE1	5XE2	5XE3	5XE4	REMARKS
23	5NY-14112-40	.VALVE, THROTTLE 1	1	1	1	1	STD
	5NY-14112-37	.VALVE, THROTTLE 1	1	1	1	1	AP
	5NY-14112-42	.VALVE, THROTTLE 1	1	1	1	1	AP
24	5ET-1416A-00	.O-RING	1	1	1	1	
25	5ET-14147-00	.O-RING	1	1	1	1	
26	51R-14146-00	.PLATE	1	1	1	1	
27	98502-05014	.SCREW, PAN HEAD	3	3	3	3	
28	2HH-14197-00	.PIPE	2	2	2	2	
29	87M-14137-00	.CLIP	3	3	3	3	
30	5MV-14194-00	.RING	1	1	1	1	
31	5MV-24514-00	.NET, FILTER 1	1	1	1	1	
32	5MV-14146-00	.PLATE	1	1	1	1	
33	5MV-14216-00	.SCREW	1	1	1	1	
34	5MV-14261-00	.HOLDER	1	1	1	1	
35	5NY-14181-00	.BODY, FLOAT CHAMBER 1	1	1	1	1	

FIG. 8 EXHAUST



REF. NO.	PART NO.	DESCRIPTION	5XE1	5XE2	5XE3	5XE4	REMARKS
1	5NY-14610-20	EXHAUST PIPE ASSY 1	1		1	1	
	5NY-14610-00	EXHAUST PIPE ASSY 1		1			
2	5MV-14642-00	SEAL, EXHAUST	2	2	2	2	
3	90507-20052	SPRING, TENSION	2	2	2	2	
4	565-14771-00	STAY, MUFFLER 1	1	1	1	1	
5	5CU-14771-00	STAY, MUFFLER 1	1	1	1	1	
6	90480-16561	GROMMET	1	1	1	1	
7	90387-063G3	COLLAR	1	1	1	1	
8	90387-062W7	COLLAR	1	1	1	1	
9	95027-06045	BOLT, FLANGE	1	1	1	1	
10	90201-06060	WASHER, PLATE	1	1	1	1	
11	90201-06071	WASHER, PLATE	1	1	1	1	
12	95027-06012	BOLT, FLANGE	1	1	1	1	
13	90119-06192	BOLT, WITH WASHER	1	1	1	1	
14	95027-06025	BOLT, FLANGE	1	1	1	1	
15	4JY-14615-00	JOINT, EXHAUST 1	1	1	1	1	
16	5XE-14753-00	SILENCER, EXHAUST	1	1	1	1	
17	5NY-1469A-00	.FIBER	1	1	1	1	
18	92017-06010	.BOLT, BUTTON HEAD	2	2	2	2	
19	95027-06025	BOLT, FLANGE	1	1	1	1	
20	90201-06071	WASHER, PLATE	1	1	1	1	
21	90387-063G3	COLLAR	1	1	1	1	
22	90480-16561	GROMMET	1	1	1	1	
23	90387-06039	COLLAR	1	1	1	1	
24	90480-16404	GROMMET	1	1	1	1	

FIG. 9 CRANKCASE

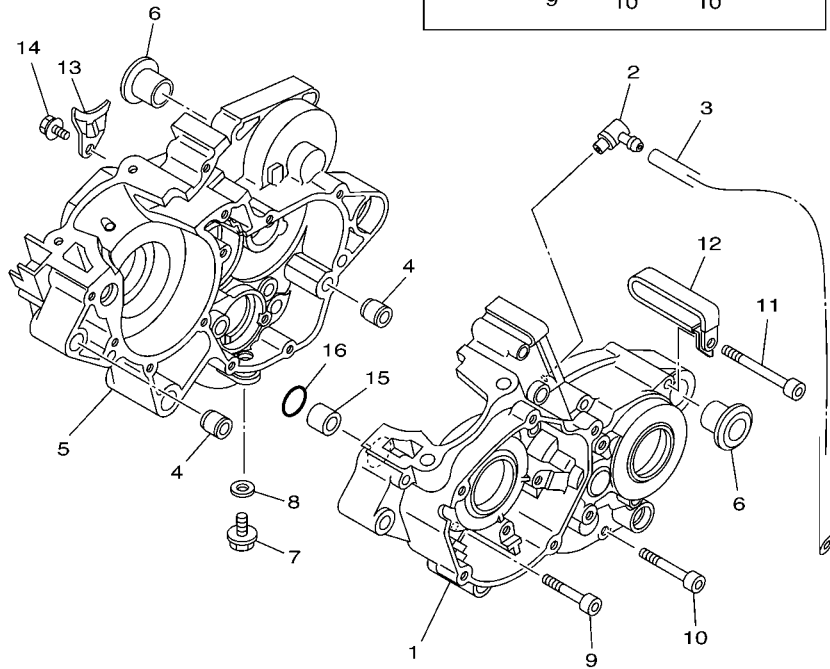
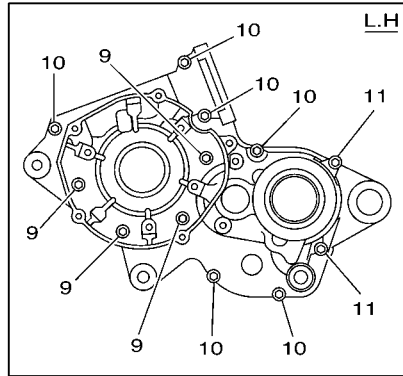

5NY1100-A090

REF. NO.	PART NO.	DESCRIPTION	5XE1	5XE2	5XE3	5XE4	REMARKS
1	5NY-15111-01	CRANKCASE 1	1	1	1	1	
2	353-13115-01	CONNECTOR, SUCTION PIPE	1	1	1	1	
3	90445-08605	HOSE	1	1	1	1	
4	93612-16254	PIN, DOWEL	2	2	2	2	
5	5NY-15121-01	CRANKCASE 2	1	1	1	1	
6	90387-18007	COLLAR	2	2	2	2	
7	90340-12059	PLUG, STRAIGHT SCREW	1	1	1	1	
8	90430-12227	GASKET	1	1	1	1	
9	91317-06045	BOLT	4	4	4	4	
10	91317-06055	BOLT	6	6	6	6	
11	91317-06070	BOLT	2	2	2	2	
12	90461-10136	CLAMP	1	1	1	1	
13	3R4-15118-00	HOLDER	1	1	1	1	
14	90105-06556	BOLT, FLANGE	1	1	1	1	
15	99590-17016	PIN, DOWEL	1	1	1	1	
16	93210-16314	O-RING	1	1	1	1	

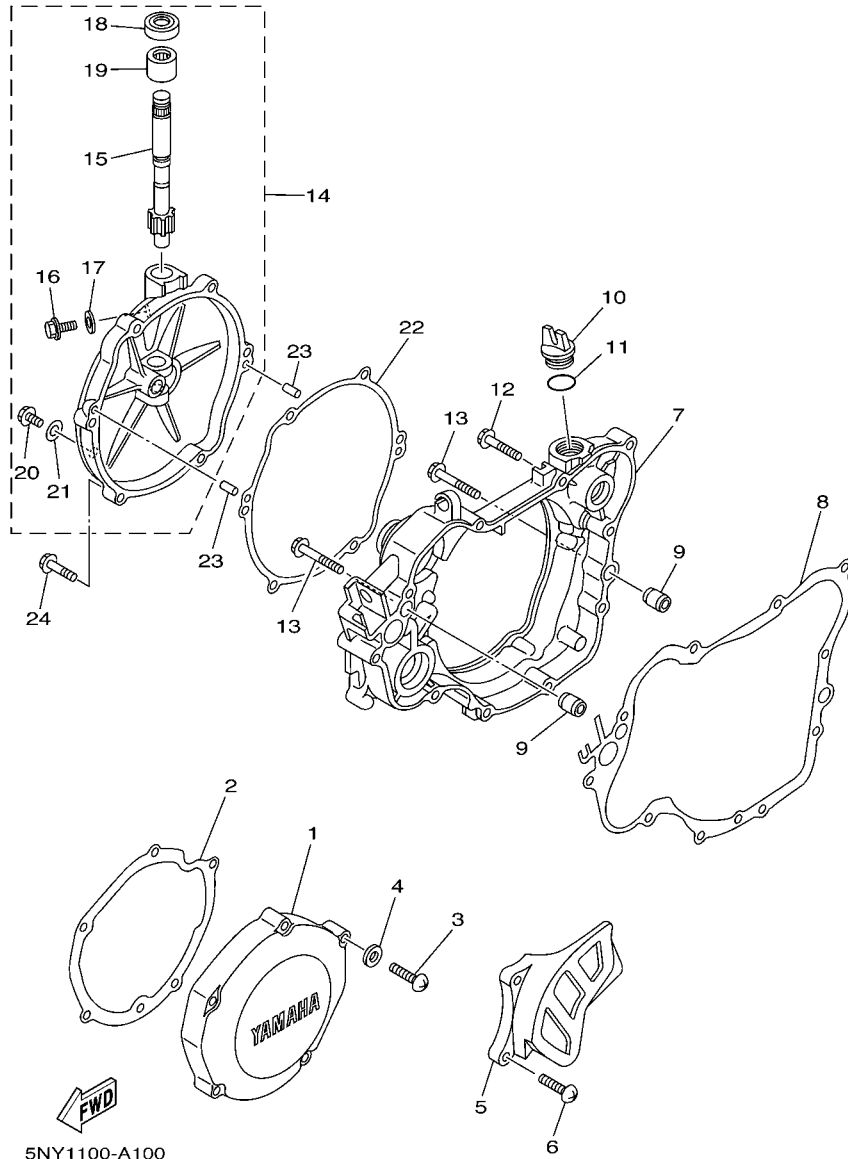
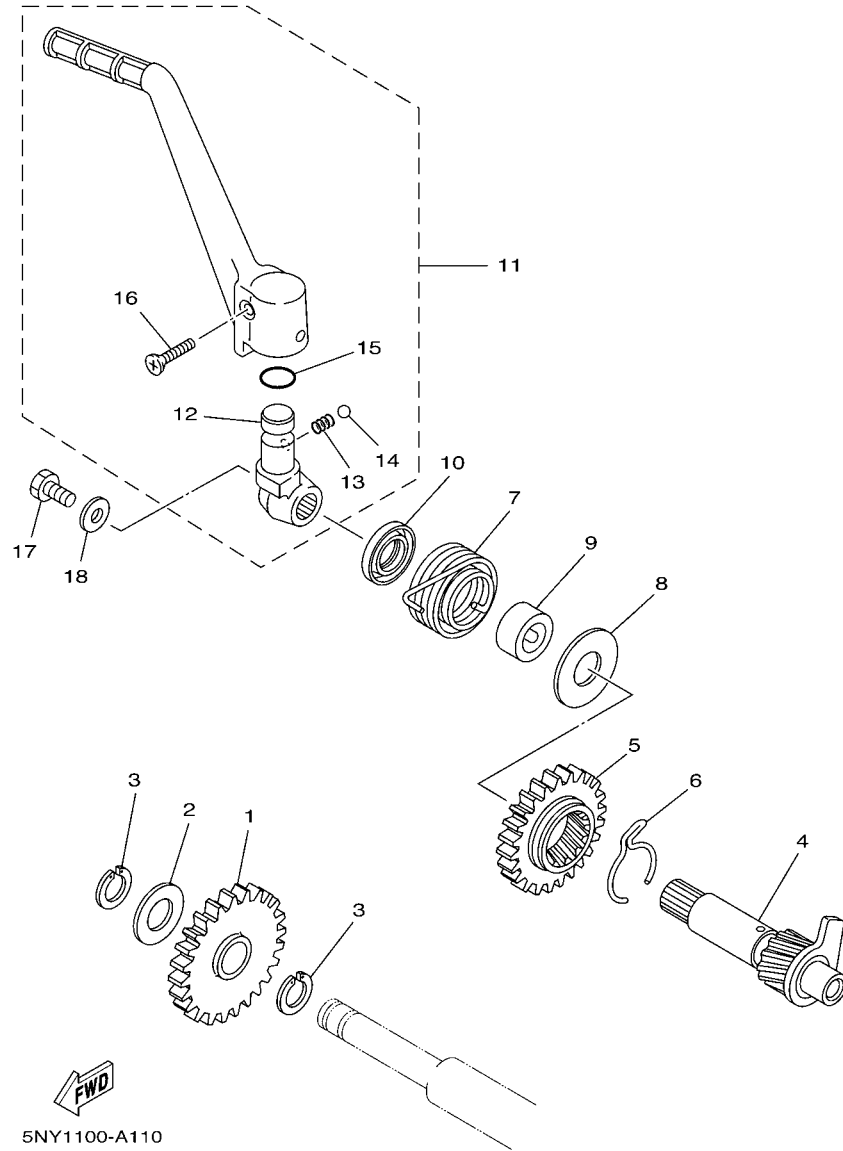

FIG. 10 CRANKCASE COVER 1

REF. NO.	PART NO.	DESCRIPTION	5XE1	5XE2	5XE3	5XE4	REMARKS
1	4JY-15411-00	COVER, CRANKCASE 1	1	1	1	1	
2	4JY-15451-10	GASKET, CRANKCASE COVER 1	1	1	1	1	
3	98507-06030	SCREW, PAN HEAD	5	5	5	5	
4	92907-06600	WASHER, PLATE	5	5	5	5	
5	4EX-15421-00	COVER, CRANKCASE 2	1	1	1	1	
6	98507-06016	SCREW, PAN HEAD	2	2	2	2	
7	4JY-15431-14	COVER, CRANKCASE 3	1	1	1	1	
8	4JY-15462-00	GASKET, CRANKCASE COVER 3	1	1	1	1	
9	99530-10114	PIN, DOWEL	2	2	2	2	
10	3Y1-15363-00	PLUG, OIL	1	1	1	1	
11	93210-19123	O-RING	1	1	1	1	
12	95027-06030	BOLT, FLANGE	6	6	6	6	
13	95027-06040	BOLT, FLANGE	2	2	2	2	
14	5NY-15490-00	COVER ASSY	1	1	1	1	
15	4EX-16382-10	.AXLE, PUSH LEVER	1	1	1	1	
16	90109-06418	.BOLT	1	1	1	1	
17	90430-06014	.GASKET	1	1	1	1	
18	93102-12224	.OIL SEAL	1	1	1	1	
19	93315-11206	.BEARING	1	1	1	1	
20	95027-06010	.BOLT, FLANGE	1	1	1	1	
21	90430-06014	.GASKET	1	1	1	1	
22	4JY-15463-10	GASKET, CARBURETOR COVER 2	1	1	1	1	
23	93604-10011	PIN, DOWEL	2	2	2	2	
24	95027-06025	BOLT, FLANGE	6	6	6	6	

FIG. 11 STARTER



5NY1100-A110

REF. NO.	PART NO.	DESCRIPTION	5XE1	5XE2	5XE3	5XE4	REMARKS
1	1LX-15651-00	GEAR, KICK IDLE	1	1	1	1	
2	90201-152H7	WASHER, PLATE	1	1	1	1	
3	93440-15012	CIRCLIP	2	2	2	2	
4	1LX-15660-03	KICK AXLE ASSY	1	1	1	1	
5	1LX-15641-00	GEAR, KICK	1	1	1	1	
6	90468-26048	CLIP	1	1	1	1	
7	90508-26450	SPRING, TORSION	1	1	1	1	
8	90201-171G4	WASHER, PLATE	1	1	1	1	
9	90560-17279	SPACER	1	1	1	1	
10	93102-17263	OIL SEAL	1	1	1	1	
11	4DB-15620-03	KICK CRANK ASSY	1	1	1	1	
12	4DB-15621-03	.BOSS, KICK CRANK	1	1	1	1	
13	90501-12081	.SPRING, COMPRESSION	1	1	1	1	
14	93507-32009	.BALL	1	1	1	1	
15	93210-15171	.O-RING	1	1	1	1	
16	90152-06010	.SCREW, COUNTERSUNK	1	1	1	1	
17	97027-06012	BOLT	1	1	1	1	
18	90201-06060	WASHER, PLATE	1	1	1	1	

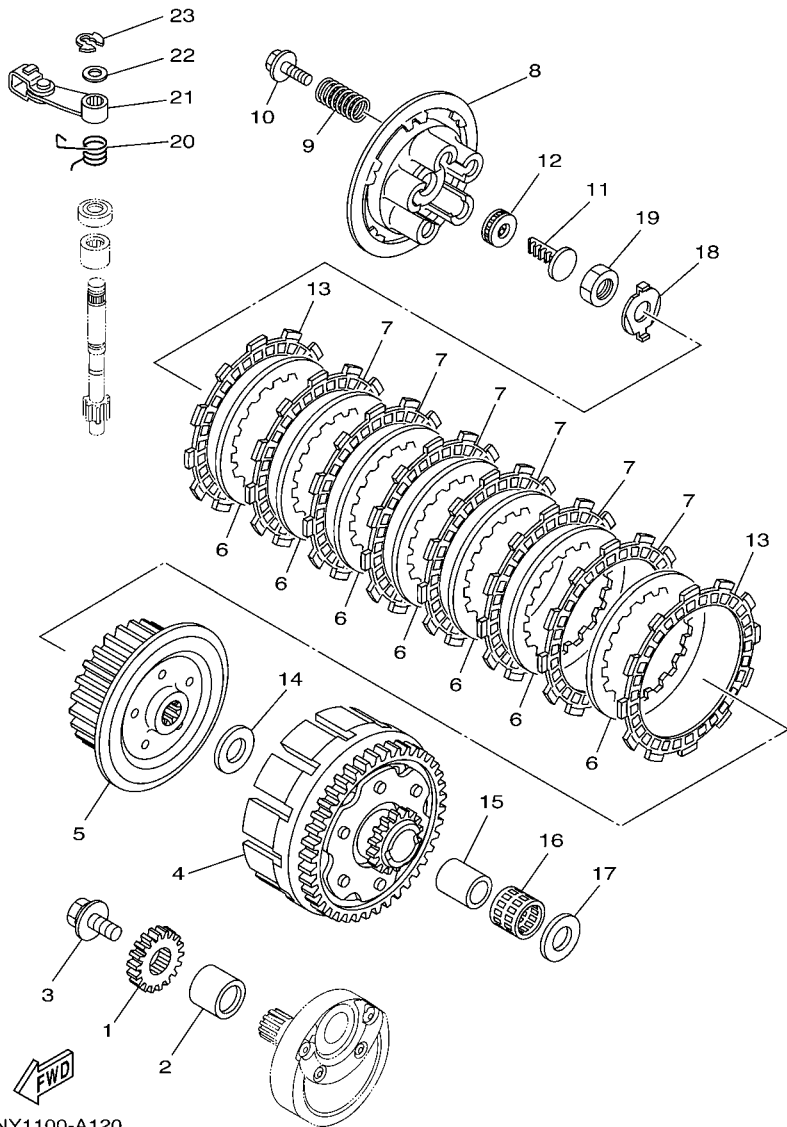

5NY1100-A120

FIG. 12 CLUTCH

REF. NO.	PART NO.	DESCRIPTION	5XE1	5XE2	5XE3	5XE4	REMARKS
1	3XJ-16111-00	GEAR, PRIMARY DRIVE	1	1	1	1	
2	90387-20007	COLLAR	1	1	1	1	
3	90105-10445	BOLT, FLANGE	1	1	1	1	
4	5NY-16150-00	PRIMARY DRIVEN GEAR COMP.	1	1	1	1	
5	5NY-16371-00	BOSS, CLUTCH	1	1	1	1	
6	3XJ-16324-01	PLATE, CLUTCH 1	7	7	7	7	
7	5DH-16321-00	PLATE, FRICTION	6	6	6	6	
8	5HD-16351-00	PLATE, PRESSURE 1	1	1	1	1	
9	90501-23391	SPRING, COMPRESSION	5	5	5	5	
10	90159-06016	SCREW, WITH WASHER	5	5	5	5	
11	3SB-16356-10	ROD, PUSH 1	1	1	1	1	
12	93340-21008	BEARING	1	1	1	1	
13	3XJ-16321-00	PLATE, FRICTION	2	2	2	2	
14	90201-20611	WASHER, PLATE	1	1	1	1	
15	3XJ-16181-00	SPACER 1	1	1	1	1	
16	93310-225N0	BEARING	1	1	1	1	
17	90201-20611	WASHER, PLATE	1	1	1	1	
18	90215-16289	WASHER, LOCK	1	1	1	1	
19	90170-16326	NUT	1	1	1	1	
20	90508-141B4	SPRING, TORSION	1	1	1	1	
21	3JD-16340-00	PUSH LEVER ASSY	1	1	1	1	
22	90201-08759	WASHER, PLATE	1	1	1	1	
23	93430-08053	CIRCLIP	1	1	1	1	

FIG. 13 TRANSMISSION

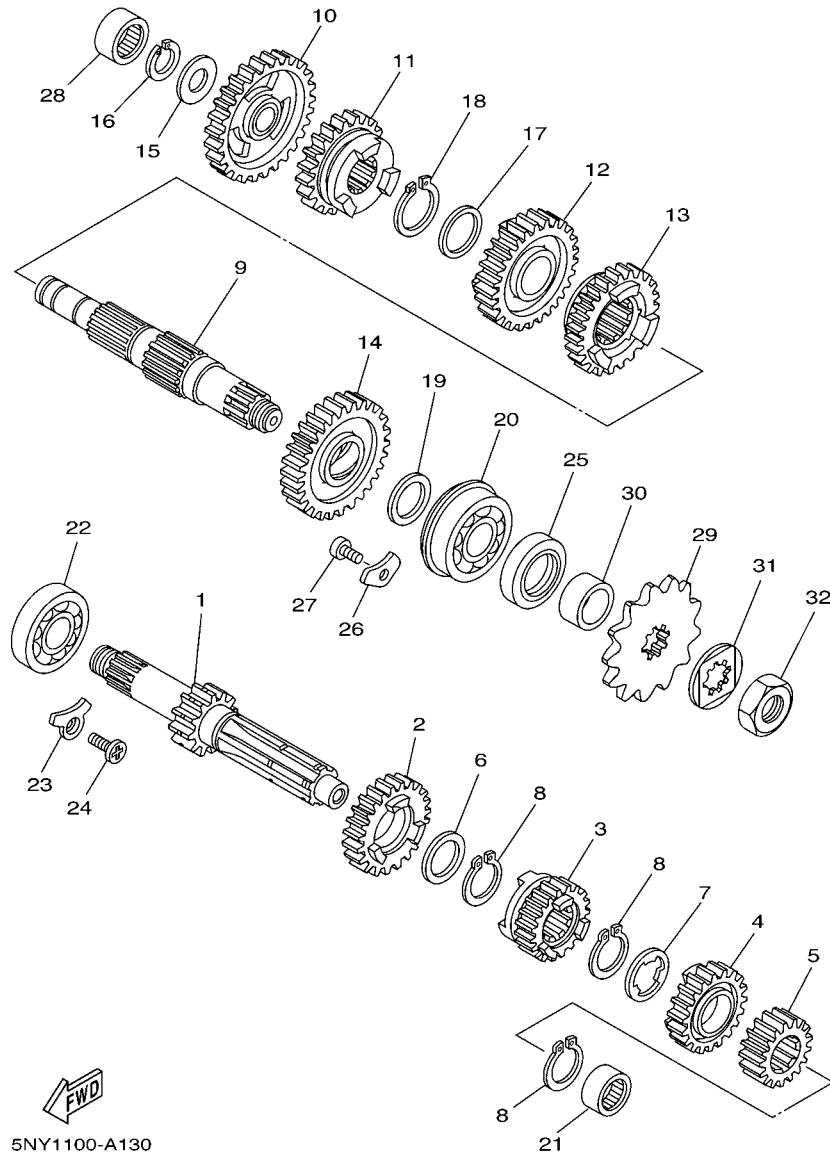

5NY1100-A130

REF. NO.	PART NO.	DESCRIPTION	5XE1	5XE2	5XE3	5XE4	REMARKS
1	5UN-17411-00	AXLE, MAIN (13T)	1	1	1	1	
2	5NY-17151-00	GEAR, 5TH PINION (23T)	1	1	1	1	
3	5NY-17131-00	GEAR, 3RD PINION (19T)	1	1	1	1	
4	5NY-17141-00	GEAR, 4TH PINION (19T)	1	1	1	1	
5	5UN-17121-00	GEAR, 2ND PINION (15T)	1	1	1	1	
6	90201-22555	WASHER, PLATE	1	1	1	1	
7	90209-18135	WASHER	1	1	1	1	
8	93410-22039	CIRCLIP	3	3	3	3	
9	5NY-17421-00	AXLE, DRIVE	1	1	1	1	
10	5UN-17211-00	GEAR, 1ST WHEEL (30T)	1	1	1	1	
11	5NY-17251-00	GEAR, 5TH WHEEL (25T)	1	1	1	1	
12	5NY-17231-00	GEAR, 3RD WHEEL (29T)	1	1	1	1	
13	5NY-17241-00	GEAR, 4TH WHEEL (24T)	1	1	1	1	
14	5UN-17221-00	GEAR, 2ND WHEEL (28T)	1	1	1	1	
15	90201-15700	WASHER, PLATE	1	1	1	1	
16	93440-15012	CIRCLIP	1	1	1	1	
17	90201-22793	WASHER, PLATE	1	1	1	1	
18	93410-22039	CIRCLIP	1	1	1	1	
19	90201-20611	WASHER, PLATE	1	1	1	1	
20	93306-30411	BEARING (B6304)	1	1	1	1	
21	93311-41530	BEARING	1	1	1	1	
22	93306-20431	BEARING (B6204Z)	1	1	1	1	
23	1LX-15383-00	PLATE, BEARING COVER	1	1	1	1	
24	90151-06037	SCREW, COUNTERSUNK	1	1	1	1	
25	93102-26042	OIL SEAL	1	1	1	1	
26	4XM-15383-00	PLATE, BEARING COVER	2	2	2	2	
27	90151-06037	SCREW, COUNTERSUNK	2	2	2	2	

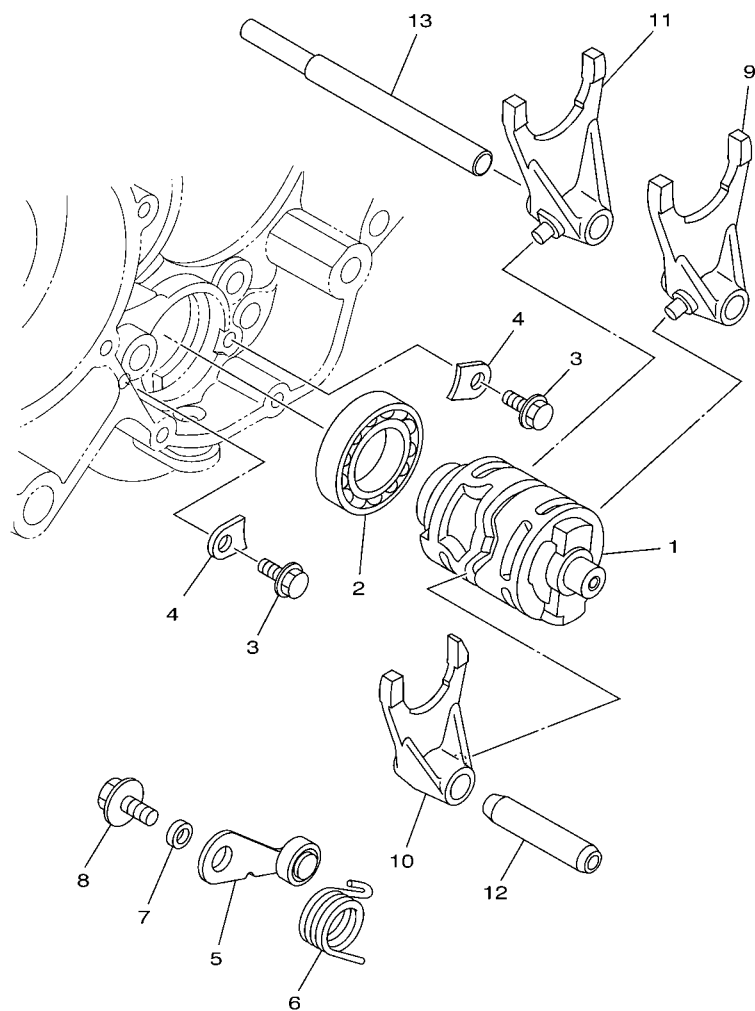

5NY1100-A140

FIG. 14 SHIFT CAM & FORK

REF. NO.	PART NO.	DESCRIPTION	5XE1	5XE2	5XE3	5XE4	REMARKS
1	5NY-18541-00	CAM, SHIFT	1	1	1	1	
2	93306-90506	BEARING	1	1	1	1	
3	90105-06553	BOLT, FLANGE	2	2	2	2	
4	5DH-18562-00	PLATE, STOPPER 2	2	2	2	2	
5	5HD-18140-00	STOPPER LEVER ASSY	1	1	1	1	
6	90508-261B7	SPRING, TORSION	1	1	1	1	
7	90387-063F7	COLLAR	1	1	1	1	
8	90159-06078	SCREW, WITH WASHER	1	1	1	1	
9	5NY-18511-00	FORK, SHIFT 1	1	1	1	1	
10	5NY-18512-00	FORK, SHIFT 2	1	1	1	1	
11	5NY-18513-00	FORK, SHIFT 3	1	1	1	1	
12	4EX-18531-00	BAR, SHIFT FORK GUIDE 1	1	1	1	1	
13	4EX-18535-00	BAR, SHIFT FORK GUIDE 2	1	1	1	1	

FIG. 15 SHIFT SHAFT

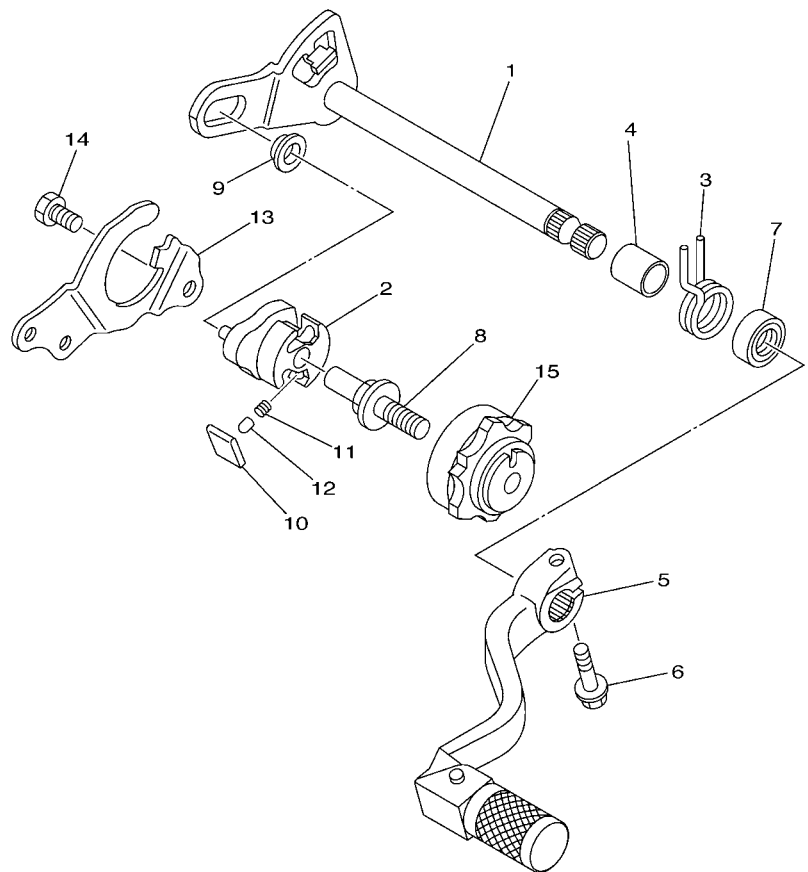

REF. NO.	PART NO.	DESCRIPTION	5XE1	5XE2	5XE3	5XE4	REMARKS
1	4SS-18101-10	SHIFT SHAFT ASSY	1	1	1	1	
2	5MV-18122-00	LEVER, SHIFT 2	1	1	1	1	
3	90508-295A7	SPRING, TORSION	1	1	1	1	
4	90560-12280	SPACER	1	1	1	1	
5	5XE-18110-00	SHIFT PEDAL ASSY	1	1	1	1	
6	95027-06020	BOLT, FLANGE	1	1	1	1	
7	93109-12012	OIL SEAL	1	1	1	1	
8	3XJ-18173-00	PIN, SHIFT	1	1	1	1	
9	3XJ-18178-00	ROLLER, SHIFT LEVER	1	1	1	1	
10	3XJ-18182-00	PAWL, SHIFTER	2	2	2	2	
11	90501-052G5	SPRING, COMPRESSION	2	2	2	2	
12	3XJ-18184-00	PIN, PAWL	2	2	2	2	
13	4JY-18172-00	GUIDE, SHIFT	1	1	1	1	
14	90101-06664	BOLT	2	2	2	2	
15	4EW-18185-00	SEGMENT	1	1	1	1	



5MV1100-1150

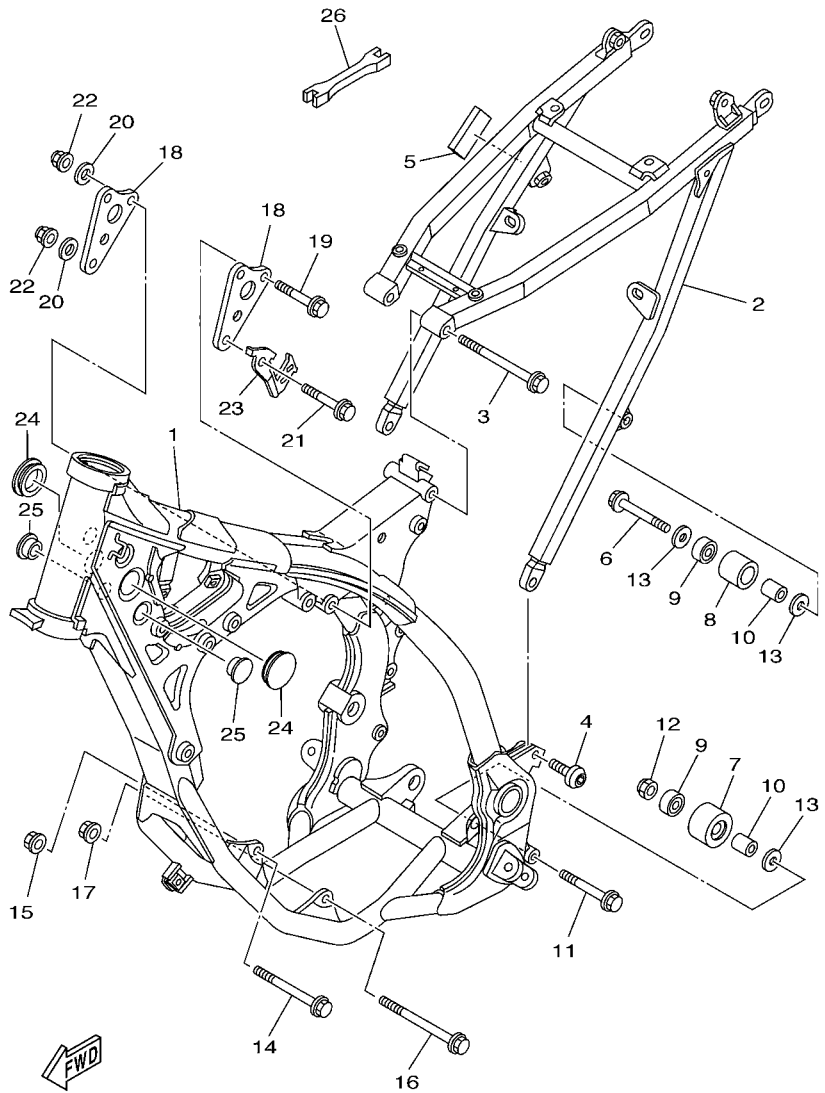

5UN1100-B160

FIG. 16 FRAME

REF. NO.	PART NO.	DESCRIPTION	5XE1	5XE2	5XE3	5XE4	REMARKS
1	5XE-21101-00	FRONT FRAME COMP.	1	1	1	1	
2	5XE-21190-00	REAR FRAME COMP.	1	1	1	1	
3	90105-08120	BOLT, FLANGE	1	1	1	1	
4	90111-08010	BOLT	2	2	2	2	
5	5GJ-21717-00	DAMPER	1	1	1	1	
6	95027-08040	BOLT, FLANGE	1	1	1	1	
7	3JD-22178-10	TENSIONER	1	1	1	1	
8	4EW-22178-00	TENSIONER	1	1	1	1	
9	93300-60804	BEARING	2	2	2	2	
10	90387-086N4	COLLAR	2	2	2	2	
11	95027-08055	BOLT, FLANGE	1	1	1	1	
12	90185-08055	NUT, SELF-LOCKING	1	1	1	1	
13	90201-086P8	WASHER, PLATE	3	3	3	3	
14	90105-10073	BOLT, FLANGE	1	1	1	1	
15	90179-10658	NUT	1	1	1	1	
16	90105-10733	BOLT, FLANGE	1	1	1	1	
17	90179-10658	NUT	1	1	1	1	
18	5NY-21425-00	BRACKET, REAR UPPER 1	2	2	2	2	
19	90105-08058	BOLT, FLANGE	2	2	2	2	
20	90201-08730	WASHER, PLATE	3	3	3	3	
21	90105-08059	BOLT, FLANGE	1	1	1	1	
22	90179-08674	NUT	3	3	3	3	
23	5UN-21274-00	BRACKET, C.D.I. UNIT	1	1	1	1	
24	90338-30256	PLUG	2	2	2	2	
25	90338-21145	PLUG	4	4	4	4	
26	5ET-28166-00	WRENCH, HEXAGON	1	1	1	1	

FIG. 17 FENDER

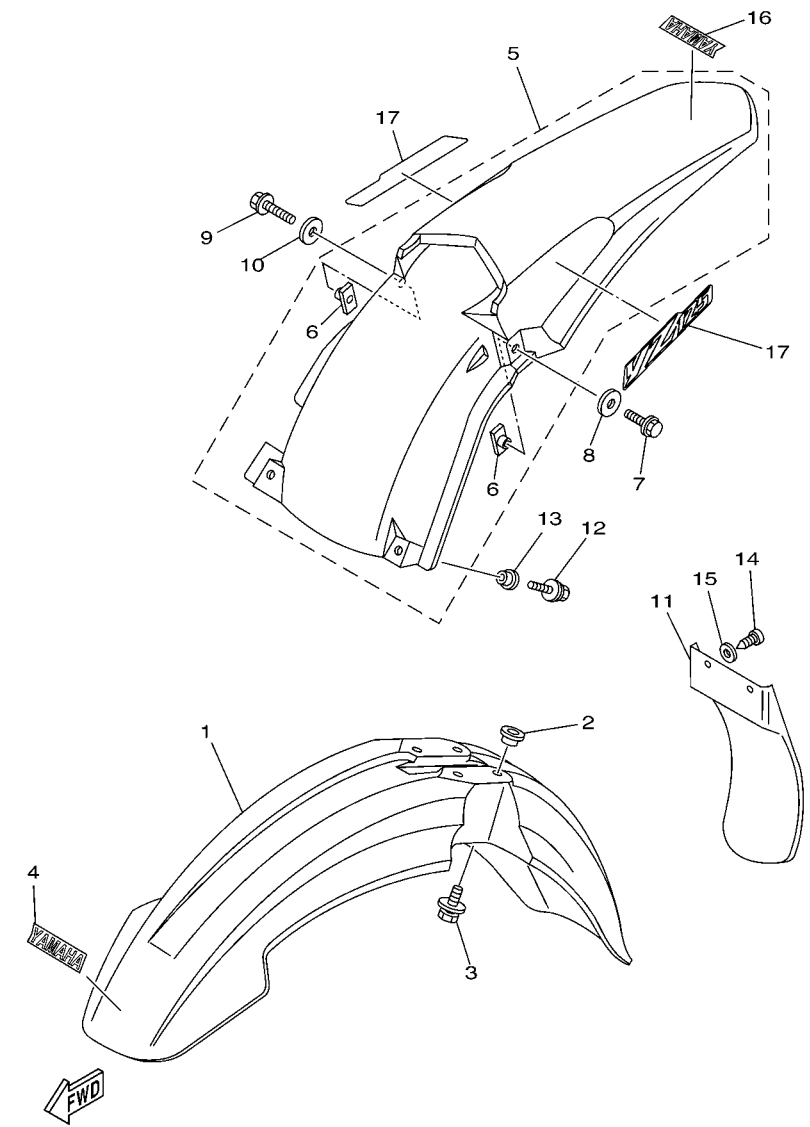

5XE1100-C170

REF. NO.	PART NO.	DESCRIPTION	5XE1	5XE2	5XE3	5XE4	REMARKS
1	5HD-21511-00	FENDER, FRONT	1	1	1	1	
2	3JD-21748-00	COLLAR	4	4	4	4	
3	90119-06096	BOLT, WITH WASHER	4	4	4	4	
4	4ES-2153E-01	EMBLEM, YAMAHA	1	1	1	1	
5	5XE-21610-00	REAR FENDER COMP.	1	1	1	1	
6	5XE-21635-00	.NUT, REAR FENDER	2	2	2	2	
7	90105-06045	BOLT, FLANGE	1	1	1	1	
8	90201-062A8	WASHER, PLATE	1	1	1	1	
9	90105-06046	BOLT, FLANGE	1	1	1	1	
10	90201-06071	WASHER, PLATE	1	1	1	1	
11	5TA-21642-00	GUARD, FLAP	1	1	1	1	
12	90119-06225	BOLT, WITH WASHER	2	2	2	2	
13	90387-06009	COLLAR	2	2	2	2	
14	97707-60016	SCREW, TAPPING	2	2	2	2	
15	90201-06557	WASHER, PLATE	2	2	2	2	
16	4ES-2153E-01	EMBLEM, YAMAHA	1	1	1	1	
17	5XE-2163G-00	EMBLEM 1	2	2	2	2	

FIG. 18 SIDE COVER

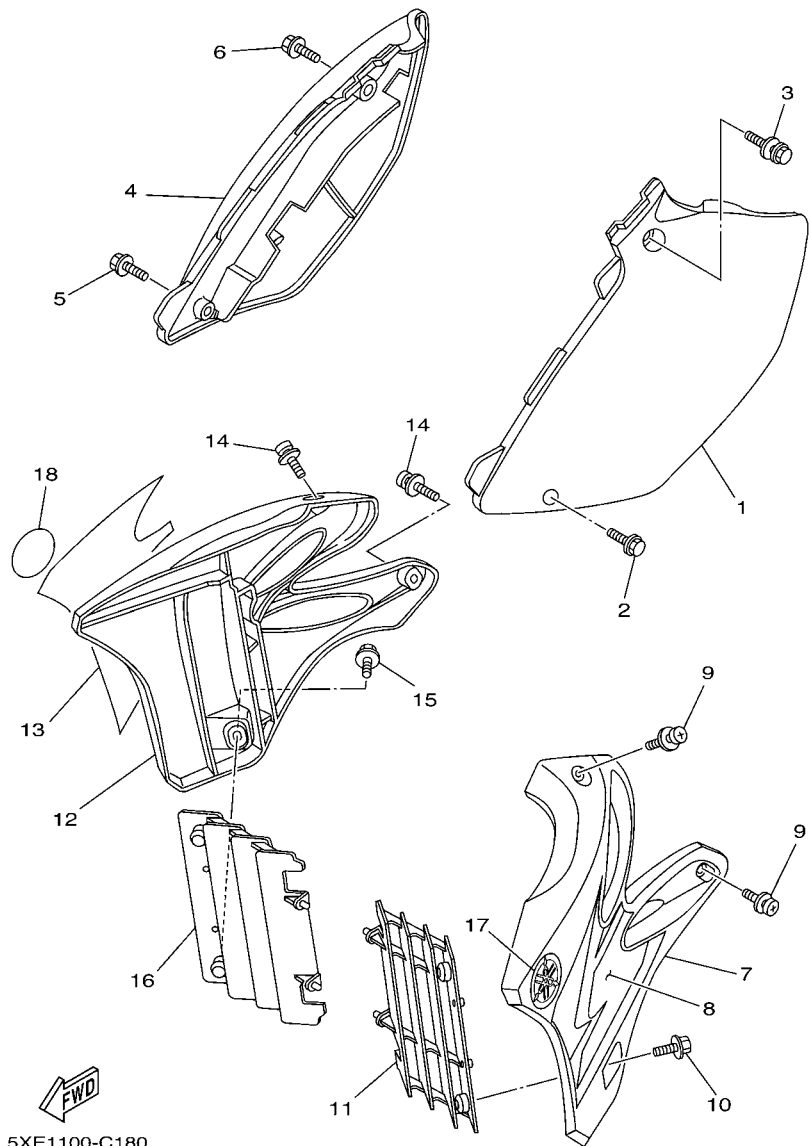

5XE1100-C180

REF. NO.	PART NO.	DESCRIPTION	5XE1	5XE2	5XE3	5XE4	REMARKS
1	5NY-21711-00	COVER, SIDE 1	1	1	1	1	
2	95827-06016	BOLT, FLANGE	1	1	1	1	
3	90119-08238	BOLT, WITH WASHER	1	1	1	1	
4	5NY-21721-00	COVER, SIDE 2	1	1	1	1	
5	95827-06016	BOLT, FLANGE	1	1	1	1	
6	90119-08238	BOLT, WITH WASHER	1	1	1	1	
7	5XE-21730-00	SIDE COVER ASSY 3	1	1	1	1	
8	5XE-2173E-00	GRAPHIC 1	1	1	1	1	
9	90159-06182	SCREW, WITH WASHER	2	2	2	2	
10	90159-06078	SCREW, WITH WASHER	1	1	1	1	
11	5NL-2172A-11	PANEL 1	1	1	1	1	
12	5XE-21740-00	SIDE COVER ASSY 4	1	1	1	1	
13	5XE-2173F-00	GRAPHIC 2	1	1	1	1	
14	90159-06182	SCREW, WITH WASHER	2	2	2	2	
15	90159-06078	SCREW, WITH WASHER	1	1	1	1	
16	5NL-2172A-11	PANEL 1	1	1	1	1	
17	5MV-2175C-00	TUNING FORK MARK	1	1	1	1	
18	5MV-2175C-00	TUNING FORK MARK	1	1	1	1	

FIG. 19 REAR ARM

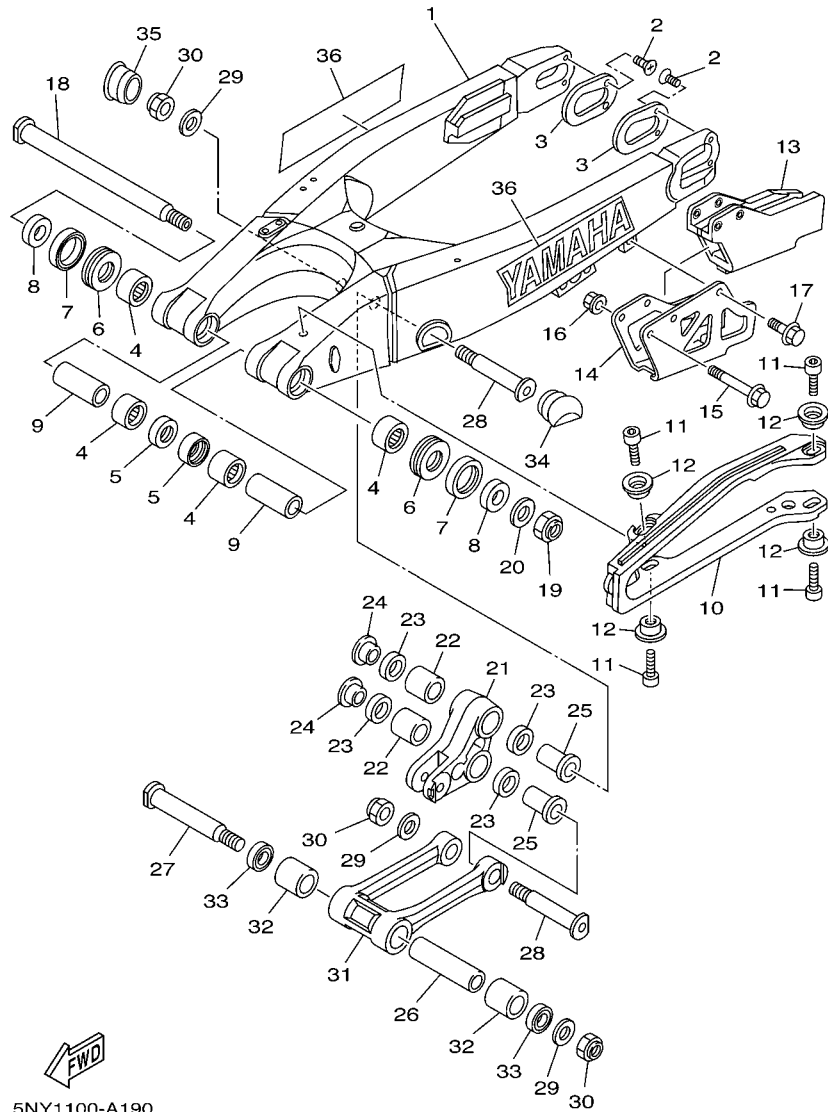

5NY1100-A190

REF. NO.	PART NO.	DESCRIPTION	5XE1	5XE2	5XE3	5XE4	REMARKS
1	5UN-22110-00	REAR ARM COMP.	1	1	1	1	
2	90151-04001	SCREW, COUNTERSUNK	4	4	4	4	
3	5UN-22355-00	PATCH	2	2	2	2	
4	93317-22262	BEARING	4	4	4	4	
5	93106-22019	OIL SEAL (DC 22-28-8)	2	2	2	2	
6	93342-22217	BEARING	2	2	2	2	
7	93109-28043	OIL SEAL	2	2	2	2	
8	90387-18005	COLLAR	2	2	2	2	
9	90387-18004	COLLAR	2	2	2	2	
10	5UN-22151-00	SEAL, GUARD	1	1	1	1	
11	91317-05008	BOLT	4	4	4	4	
12	5JG-22156-00	WASHER, PLATE	4	4	4	4	
13	5UN-22199-00	SUPPORT, CHAIN	1	1	1	1	
14	5UN-22128-00	COVER, THRUST 1	1	1	1	1	
15	95027-06050	BOLT, FLANGE	2	2	2	2	
16	90179-06568	NUT	2	2	2	2	
17	95027-06010	BOLT, FLANGE	1	1	1	1	
18	5NY-22141-01	SHAFT, PIVOT	1	1	1	1	
19	90185-16127	NUT, SELF-LOCKING	1	1	1	1	
20	90201-160F6	WASHER, PLATE	1	1	1	1	
21	5NY-2217A-00	ARM, RELAY	1	1	1	1	
22	93315-32056	BEARING	2	2	2	2	
23	93109-20076	OIL SEAL	4	4	4	4	
24	90387-16005	COLLAR	2	2	2	2	
25	90387-16007	COLLAR	2	2	2	2	
26	90387-167Y9	COLLAR	1	1	1	1	
27	5NY-22121-00	SHAFT 1	1	1	1	1	

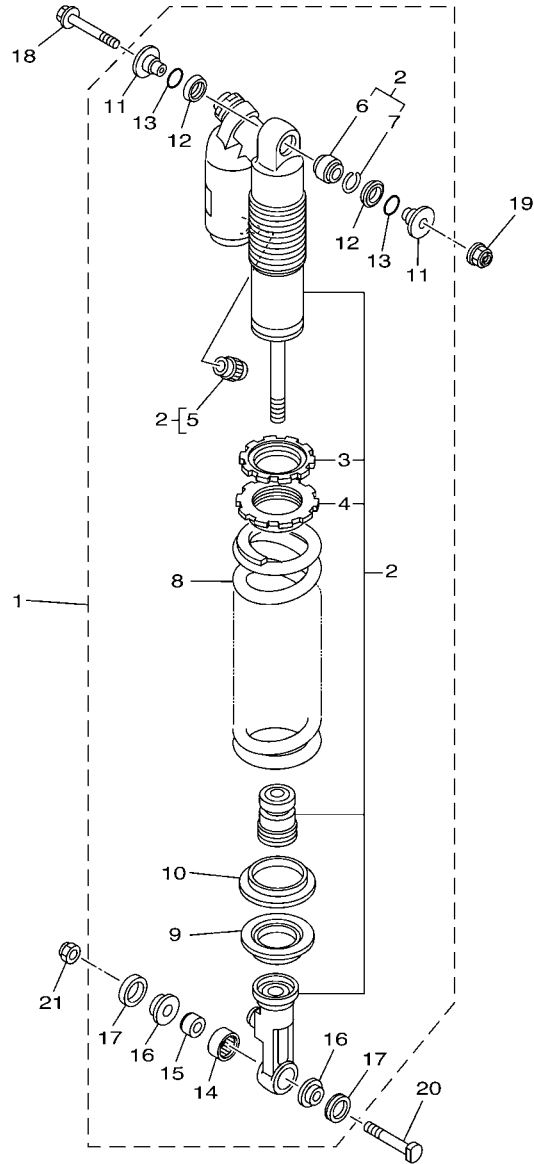

5NY1100-A200

FIG. 20 REAR SUSPENSION

REF. NO.	PART NO.	DESCRIPTION	5XE1	5XE2	5XE3	5XE4	REMARKS
1	5XE-22210-00	SHOCK ABSORBER ASSY, REAR	1				UR FOR USA
	5XE-22210-30	SHOCK ABSORBER ASSY, REAR	1				UR FOR CAN
	5XE-22210-40	SHOCK ABSORBER ASSY, REAR	1			1	UR FOR ZAF,OCE
	5XE-22210-10	SHOCK ABSORBER ASSY, REAR		1			
	5XE-22210-20	SHOCK ABSORBER ASSY, REAR			1		
2	5XE-22201-00	.DAMPER SUB ASSY	1				UR FOR USA
	5XE-22201-30	.DAMPER SUB ASSY	1				UR FOR CAN
	5XE-22201-40	.DAMPER SUB ASSY	1			1	UR FOR ZAF,OCE
	5XE-22201-10	.DAMPER SUB ASSY		1			
	5XE-22201-20	.DAMPER SUB ASSY			1		
3	3SP-22234-00	..GUIDE, SPRING 3	1	1	1	1	
4	3SP-22213-00	..SEAT, SPRING UPPER	1	1	1	1	
5	509-23184-L0	..CAP, AIR VALVE	1	1	1	1	
6	4JX-22226-00	..BUSH, SHOCK ABSORBER LOWER	1	1	1	1	
7	5DH-23183-00	..CIRCLIP	1	1	1	1	
8	5UN-22212-10	.SPRING (K=44N/MM)	1		1	1	
	5UN-22212-B0	.SPRING (K=APPROX.46N/MM)		1			
9	5XE-22214-00	.GUIDE, SPRING 1	1	1	1	1	
10	5MV-22224-00	.GUIDE, SPRING 2	1	1	1	1	
11	5DH-22253-00	.COLLAR, DISTANCE	2	2	2	2	
12	3JE-22475-00	.SEAL, DUST	2	2	2	2	
13	4EW-22474-00	.SEAL, RING	2	2	2	2	
14	5MV-22176-00	.BEARING	1	1	1	1	
15	5MV-22184-00	.BUSH	1	1	1	1	
16	5MV-22253-00	.COLLAR, DISTANCE	2	2	2	2	
17	5NY-22475-00	.SEAL, DUST	2	2	2	2	
18	5XE-22242-00	BOLT 2	1	1	1	1	

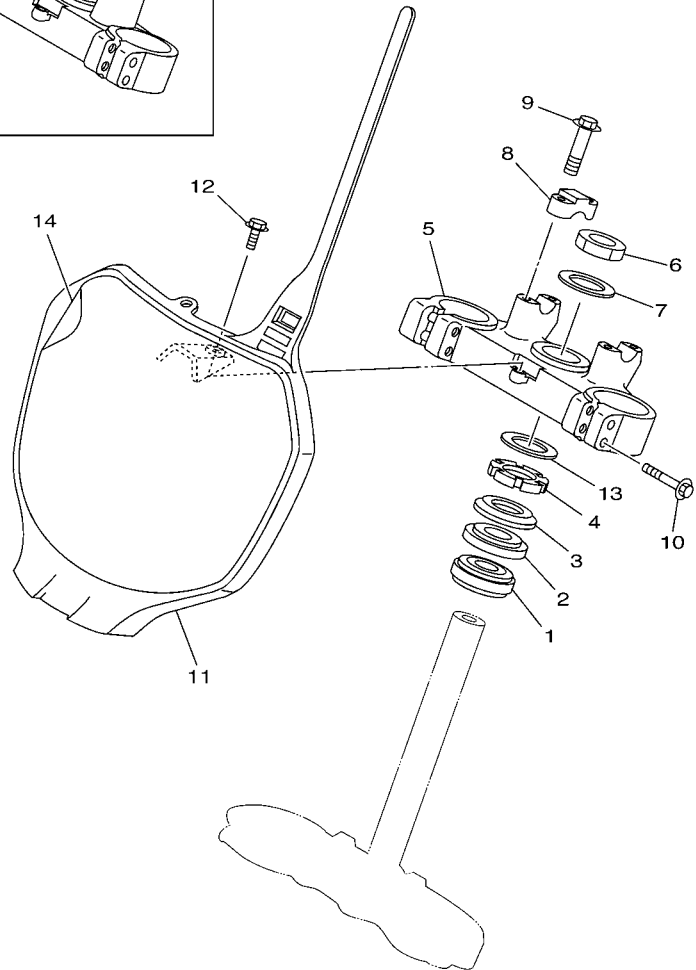
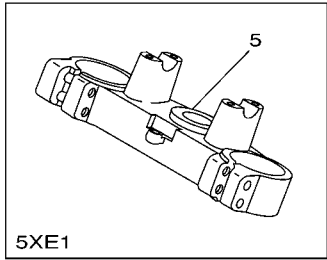

FIG. 21 STEERING

REF. NO.	PART NO.	DESCRIPTION	5XE1	5XE2	5XE3	5XE4	REMARKS
1	93332-00081	BEARING	1	1	1	1	
2	93332-00068	BEARING	1	1	1	1	
3	4EW-23416-00	COVER, BALL RACE 2	1	1	1	1	
4	90179-28003	NUT	1	1	1	1	
5	5XE-23435-00	CROWN, HANDLE	1				
	5XE-23435-10	CROWN, HANDLE		1	1	1	
6	5TA-23357-00	NUT	1	1	1	1	
7	90201-247L2	WASHER, PLATE	1	1	1	1	
8	5XE-23441-00	HOLDER, HANDLE UPPER	2	2	2	2	
9	95027-08035	BOLT, FLANGE	4	4	4	4	
10	95027-08040	BOLT, FLANGE	4	4	4	4	
11	5HD-23485-10	PLATE, NUMBER	1	1	1	1	
12	90119-06225	BOLT, WITH WASHER	1	1	1	1	
13	90201-286K9	WASHER, PLATE	1	1	1	1	
14	5HD-2339E-00	GRAPHIC 1	1	1	1	1	

5XE1100-C210

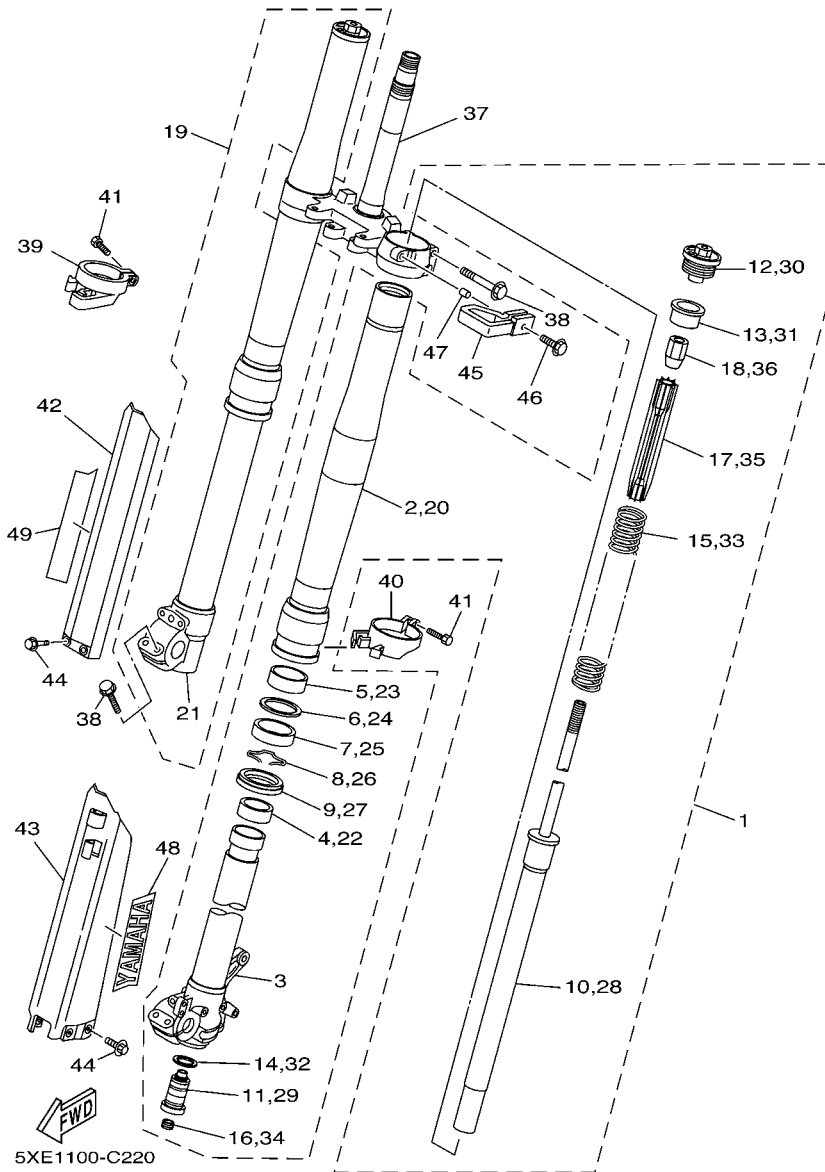

FIG. 22 FRONT FORK

REF. NO.	PART NO.	DESCRIPTION	5XE1	5XE2	5XE3	5XE4	REMARKS
1	5XE-23102-00	FRONT FORK ASSY (L.H)	1			1	
	5XE-23102-10	FRONT FORK ASSY (L.H)		1			
	5XE-23102-20	FRONT FORK ASSY (L.H)			1		
2	5XE-23136-L0	.TUBE, OUTER (RIGHT)	1	1	1	1	
3	5XE-23120-L0	.INNER TUBE COMP.2	1	1	1	1	
4	5XE-23171-L0	.PISTON, FRONT FORK	1	1	1	1	
5	5XE-23125-L0	.METAL, SLIDE 1	1	1	1	1	
6	5XE-23146-L0	.WASHER, OIL SEAL	1	1	1	1	
7	5XE-23145-L0	.OIL SEAL	1	1	1	1	
8	5XE-23153-L0	.RING, SNAP	1	1	1	1	
9	5XE-23144-L0	.SEAL, DUST	1	1	1	1	
10	5XE-23170-L0	.CYLINDER COMP., FRONT FORK	1	1	1	1	
11	5XE-2316A-L0	.VALVE COMP.	1		1	1	
	5XE-2316A-M0	.VALVE COMP.		1			
12	5XE-23111-L0	.BOLT, CAP	1	1	1	1	
13	5XE-23117-L0	.GUIDE, SPRING	1	1	1	1	
14	4SS-23158-L0	.GASKET	1	1	1	1	
15	5XE-23141-L0	.SPRING, FRONT FORK (K=4.0N/MM	1	1	1	1	
16	3JD-2312G-L0	.PLUG	1	1	1	1	
17	5XE-23142-L0	.SEAT, SPRING UPPER	1	1	1	1	
18	5XE-23393-L0	.NUT, SPECIAL	1	1	1	1	
19	5XE-23103-00	FRONT FORK ASSY (R.H)	1			1	
	5XE-23103-10	FRONT FORK ASSY (R.H)		1			
	5XE-23103-20	FRONT FORK ASSY (R.H)			1		
20	5XE-23136-L0	.TUBE, OUTER (RIGHT)	1	1	1	1	
21	5XE-23110-L0	.INNER TUBE COMP.1	1	1	1	1	
22	5XE-23171-L0	.PISTON, FRONT FORK	1	1	1	1	

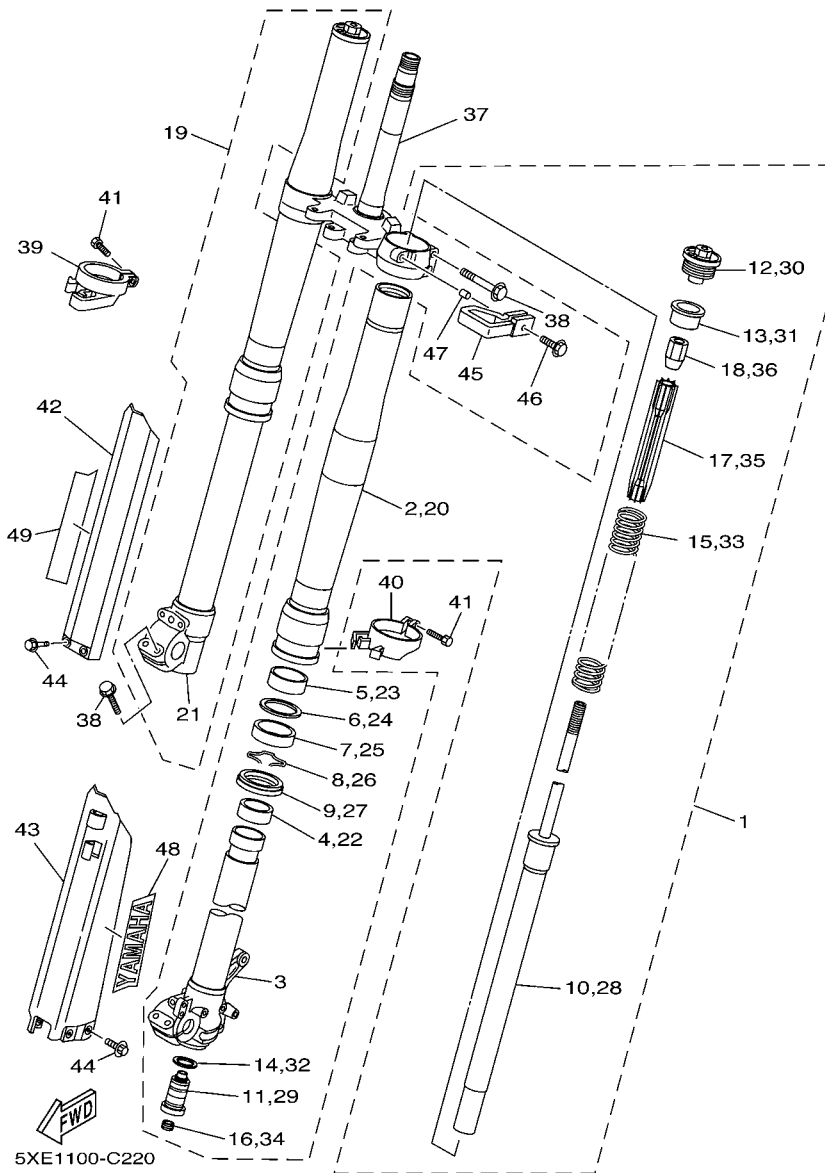

FIG. 22 FRONT FORK

REF. NO.	PART NO.	DESCRIPTION	5XE1	5XE2	5XE3	5XE4	REMARKS
23	5XE-23125-L0	.METAL, SLIDE 1	1	1	1	1	
24	5XE-23146-L0	.WASHER, OIL SEAL	1	1	1	1	
25	5XE-23145-L0	.OIL SEAL	1	1	1	1	
26	5XE-23153-L0	.RING, SNAP	1	1	1	1	
27	5XE-23144-L0	.SEAL, DUST	1	1	1	1	
28	5XE-23170-L0	.CYLINDER COMP., FRONT FORK	1	1	1	1	
29	5XE-2316A-L0	.VALVE COMP.	1		1	1	
	5XE-2316A-M0	.VALVE COMP.		1			
30	5XE-23111-L0	.BOLT, CAP	1	1	1	1	
31	5XE-23117-L0	.GUIDE, SPRING	1	1	1	1	
32	4SS-23158-L0	.GASKET	1	1	1	1	
33	5XE-23141-L0	.SPRING, FRONT FORK (K=4.0N/MM	1	1	1	1	
34	3JD-2312G-L0	.PLUG	1	1	1	1	
35	5XE-23142-L0	.SEAT, SPRING UPPER	1	1	1	1	
36	5XE-23393-L0	.NUT, SPECIAL	1	1	1	1	
37	5XE-23340-L0	UNDER BRACKET COMP.	1	1	1	1	
38	5NY-23346-L0	BOLT 1	4	4	4	4	
39	5XE-2314G-L0	PROTECTOR GUIDE COMP., 2	1	1	1	1	
40	5XE-2314F-L0	PROTECTOR GUIDE COMP., 1	1	1	1	1	
41	4SS-23346-L0	BOLT 1	2	2	2	2	
42	5TA-2314J-00	PROTECTOR COMP., 2	1	1	1	1	
43	5TA-2314H-00	PROTECTOR COMP., 1	1	1	1	1	
44	3SP-23356-L0	BOLT 2	6	6	6	6	
45	5XE-23389-00	GUIDE, CABLE	1	1	1	1	
46	95027-06020	BOLT, FLANGE	1	1	1	1	
47	5XE-23113-00	COLLAR	1	1	1	1	
48	4XL-2153A-10	EMBLEM, YAMAHA	1	1	1	1	

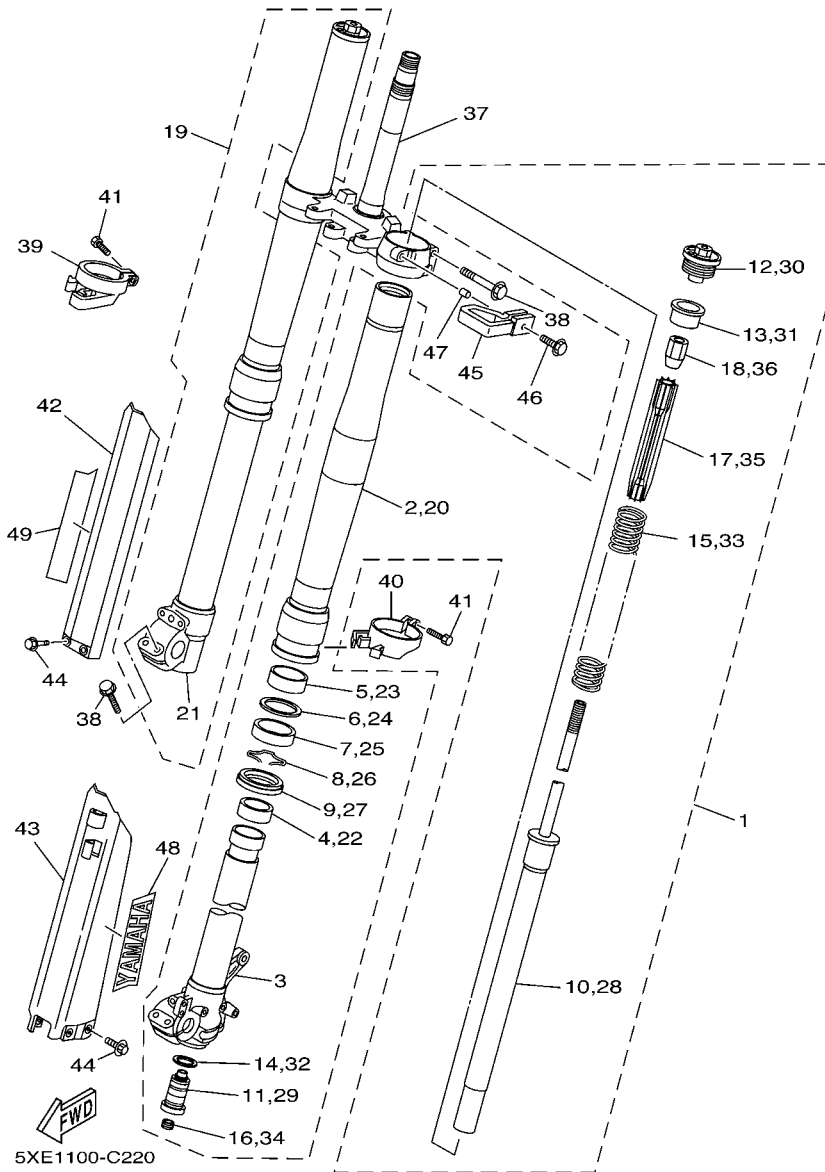
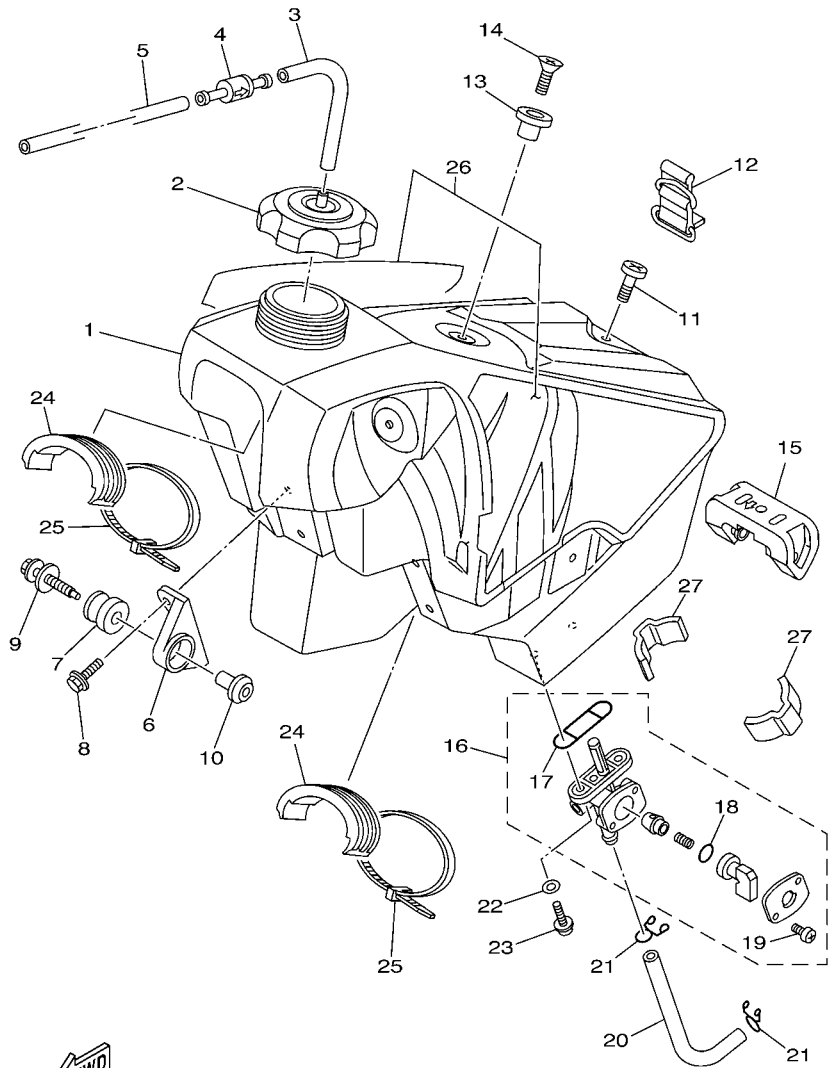

FIG. 22 FRONT FORK

REF. NO.	PART NO.	DESCRIPTION	5XE1	5XE2	5XE3	5XE4	REMARKS
49	4XL-2153A-10	EMBLEM, YAMAHA	1	1	1	1	

FIG. 23 FUEL TANK



5XE1100-C230

REF. NO.	PART NO.	DESCRIPTION	5XE1	5XE2	5XE3	5XE4	REMARKS
1	5XE-24110-00	FUEL TANK COMP.	1	1	1	1	
2	5NY-24610-00	CAP ASSY	1	1	1	1	
3	90445-09220	HOSE (L30)	1	1	1	1	
4	3XJ-24380-00	PIPE JOINT ASSY	1	1	1	1	
5	90445-09104	HOSE	1	1	1	1	
6	5XE-24144-00	HOLDER, DAMPER	2	2	2	2	
7	90480-18549	GROMMET	2	2	2	2	
8	95027-06016	BOLT, FLANGE	4	4	4	4	
9	5XE-24176-00	BOLT 1	2	2	2	2	
10	5NY-24186-00	WASHER, SPECIAL	2	2	2	2	
11	98907-06025	SCREW, BIND	1	1	1	1	
12	3SP-24173-00	BAND, TANK FITTING 1	1	1	1	1	
13	4EW-2412F-00	BRACKET, SEAT	1	1	1	1	
14	98707-06025	SCREW, FLAT HEAD	1	1	1	1	
15	4SS-24181-00	DAMPER, LOCATING 1	1	1	1	1	
16	3JD-24500-01	FUEL COCK ASSY 1	1	1	1	1	
17	4X8-24512-00	.O-RING	1	1	1	1	
18	3AJ-24534-00	.SEAL, COCK	1	1	1	1	
19	97801-03008	.SCREW, PAN HEAD	2	2	2	2	
20	90445-111J0	HOSE (L145)	1	1	1	1	
21	90467-10008	CLIP	2	2	2	2	
22	90202-05193	WASHER, PLATE	2	2	2	2	
23	90149-06011	SCREW	2	2	2	2	
24	5NY-24182-00	DAMPER, LOCATING 2	2	2	2	2	
25	90465-13275	CLAMP	2	2	2	2	
26	5XE-24240-00	GRAPHIC SET	1	1	1	1	
27	5XE-24183-00	DAMPER, LOCATING 3	2	2	2	2	

FIG. 25 FRONT WHEEL

REF.7
 94108-21015 (D739FA)
 FOR USA,AUS,NZL
 94108-2112Y (D755F)
 FOR CAN,EUR

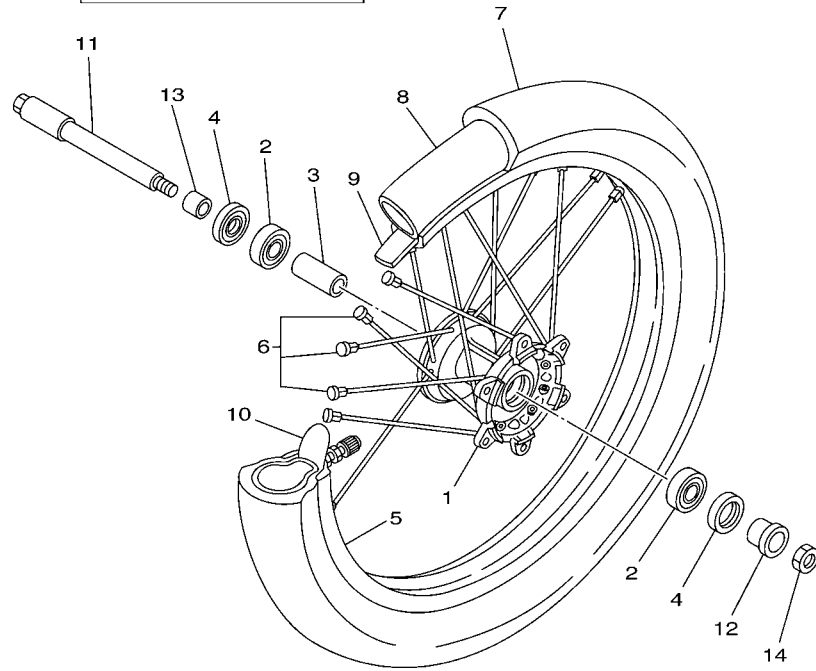

REF. NO.	PART NO.	DESCRIPTION	5XE1	5XE2	5XE3	5XE4	REMARKS
1	5NY-25111-00	HUB, FRONT	1	1	1	1	
2	93306-90403	BEARING	2	2	2	2	
3	5NY-25117-00	SPACER, BEARING	1	1	1	1	
4	93102-26468	OIL SEAL	2	2	2	2	
5	94416-21003	RIM (1.60-21)	1	1	1	1	
6	5NY-25104-00	SPOKE SET, FRONT	1	1	1	1	
7	94108-2112Y	TIRE (80/100-21 51M D755F)	1	1			UR DUNLOP
	94108-21015	TIRE (80/100-21 51M D739FA)	1			1	UR DUNLOP
	94108-21012	TIRE(80/100-21 51M M601)			1		BRIDGESTONE
8	94227-21101	TUBE (80/100-21 M/C TR4)	1	1		1	DUNLOP
	94209-21229	TUBE (80/100-21 M/C TR4)			1		BRIDGESTONE
9	94309-21161	BAND, RIM (1.60-21)	1	1		1	DUNLOP
	94330-21084	BAND,RIM (1.60-21)			1		BRIDGESTONE
10	5SF-25394-00	SPACER, BEAD	1	1	1	1	
11	5BE-25181-00	AXLE, WHEEL	1	1	1	1	
12	5NY-25183-00	COLLAR, WHEEL	1	1	1	1	
13	5NY-25186-00	COLLAR, WHEEL	1	1	1	1	
14	90179-16672	NUT	1	1	1	1	



5XF1100-C250

D6

FIG. 26 FRONT BRAKE CALIPER

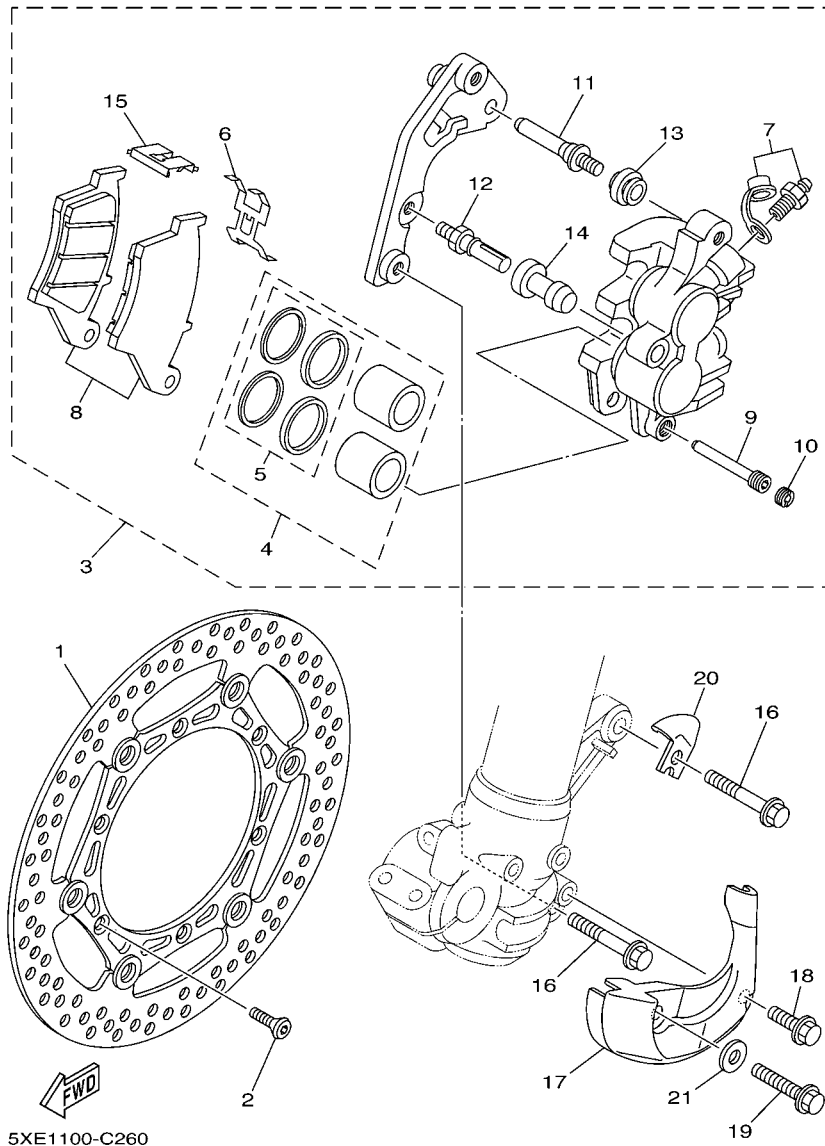

REF. NO.	PART NO.	DESCRIPTION	5XE1	5XE2	5XE3	5XE4	REMARKS
1	5MV-2581T-00	DISC BRAKE ASSY	1	1	1	1	
2	90149-06327	SCREW	6	6	6	6	
3	5UN-2580T-00	CALIPER ASSY (LEFT)	1	1	1	1	
4	5UN-W0057-00	.PISTON ASSY, CALIPER	1	1	1	1	
5	3JD-W0047-00	..CALIPER SEAL KIT	1	1	1	1	
6	5DH-25919-00	.SUPPORT, PAD	1	1	1	1	
7	1UY-W0048-50	.BLEED SCREW KIT	1	1	1	1	
8	5MV-W0045-01	.BRAKE PAD KIT	1	1	1	1	
9	5DH-25933-00	.WASHER, PAD PIN	1	1	1	1	
10	5DH-25916-00	.PLUG	1	1	1	1	
11	3SP-25926-51	.BOLT	1	1	1	1	
12	3SP-25914-51	.PIN, SLIDE	1	1	1	1	
13	3JD-25917-00	.BOOT, CALIPER	1	1	1	1	
14	1UY-25937-51	.BOOT 2	1	1	1	1	
15	5DH-25849-00	.RETAINER, CALIPER	1	1	1	1	
16	90105-08659	BOLT, FLANGE	2	2	2	2	
17	5DH-2314E-00	COVER, HOSE	1	1	1	1	
18	95827-06012	BOLT, FLANGE	1	1	1	1	
19	95027-08020	BOLT, FLANGE	1	1	1	1	
20	5DH-25875-00	HOLDER, BRAKE HOSE 1	1	1	1	1	
21	92907-08200	WASHER	1	1	1	1	

FIG. 27 REAR WHEEL

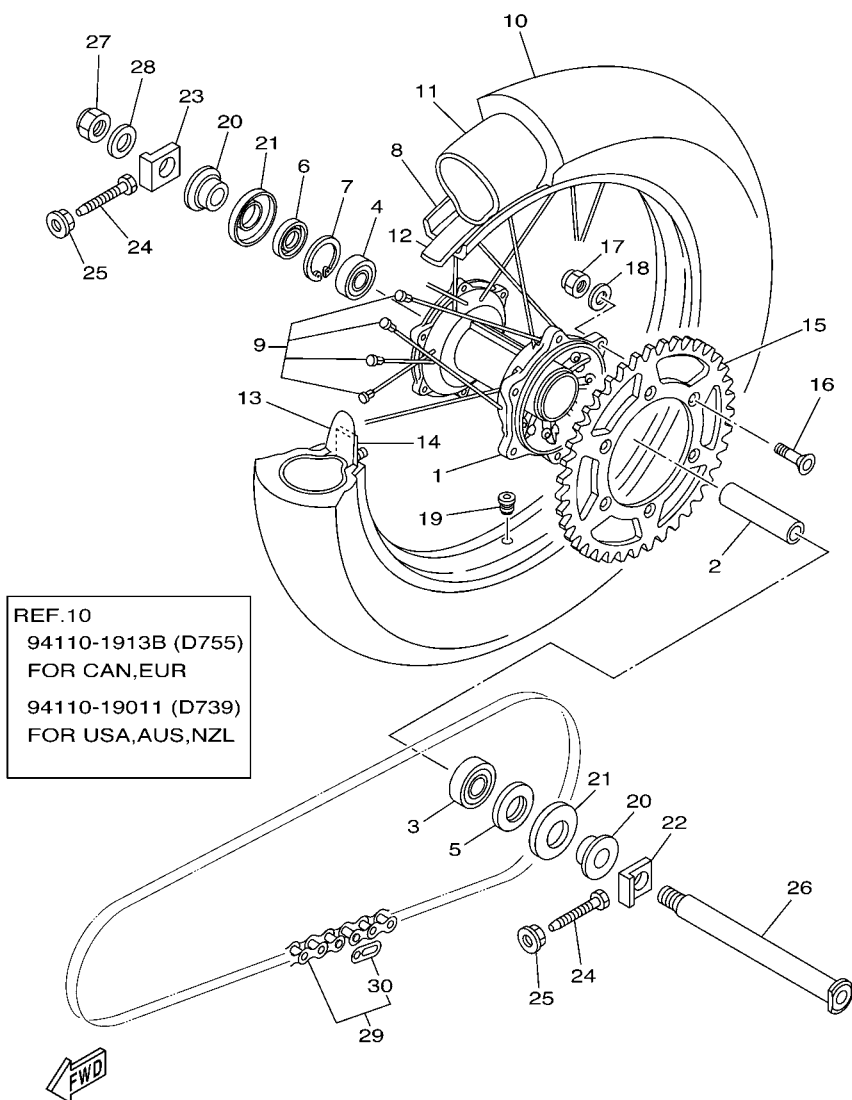

REF. 10
 94110-1913B (D755)
 FOR CAN, EUR
 94110-19011 (D739)
 FOR USA, AUS, NZL

5XE1100-C270

REF. NO.	PART NO.	DESCRIPTION	5XE1	5XE2	5XE3	5XE4	REMARKS
1	5ET-25311-00	HUB, REAR	1	1	1	1	
2	5ET-25317-00	SPACER, BEARING	1	1	1	1	
3	93306-27205	BEARING	1	1	1	1	
4	93306-07202	BEARING	1	1	1	1	
5	93106-30044	OIL SEAL	1	1	1	1	
6	93106-30045	OIL SEAL	1	1	1	1	
7	99009-45500	CIRCLIP	1	1	1	1	
8	94418-19601	RIM (1.85-19)	1	1	1	1	
9	5HD-25304-00	SPOKE SET, REAR	1	1	1	1	
10	94110-1913B	TIRE (100/90-19 57M D755)	1	1			UR DUNLOP
	94110-19011	TIRE (100/90-19 57M D739)	1			1	UR DUNLOP
	94110-19009	TIRE(100/90-19 51M M602)			1		BRIDGESTONE
11	94210-19224	TUBE (100/90-19 M/C TR4 BTL)	1	1		1	DUNLOP
	94210-19222	TUBE (100/90-19 M/C TR4)			1		BRIDGESTONE
12	94321-19135	BAND, RIM (1.85-19)	1	1		1	DUNLOP
	94316-19156	BAND, RIM (1.85-19)			1		BRIDGESTONE
13	4XM-25394-00	SPACER, BEAD	1	1	1	1	
14	4XM-25364-00	DAMPER	1	1	1	1	
15	5ET-25447-00	SPROCKET, DRIVEN (47T)	1	1	1	1	AP
	5NY-25449-00	SPROCKET, DRIVEN (49T)	1	1	1	1	STD
	5NY-25448-00	SPROCKET, DRIVEN (48T)	1	1	1	1	AP
	5NY-25450-00	SPROCKET, DRIVEN (50T)	1	1	1	1	AP
	5NY-25451-00	SPROCKET, DRIVEN (51T)	1	1	1	1	AP
	5NY-25452-00	SPROCKET, DRIVEN (52T)	1	1	1	1	AP
16	90109-081G1	BOLT	6	6	6	6	
17	90185-08169	NUT, SELF-LOCKING	6	6	6	6	
18	90201-08326	WASHER, PLATE	6	6	6	6	

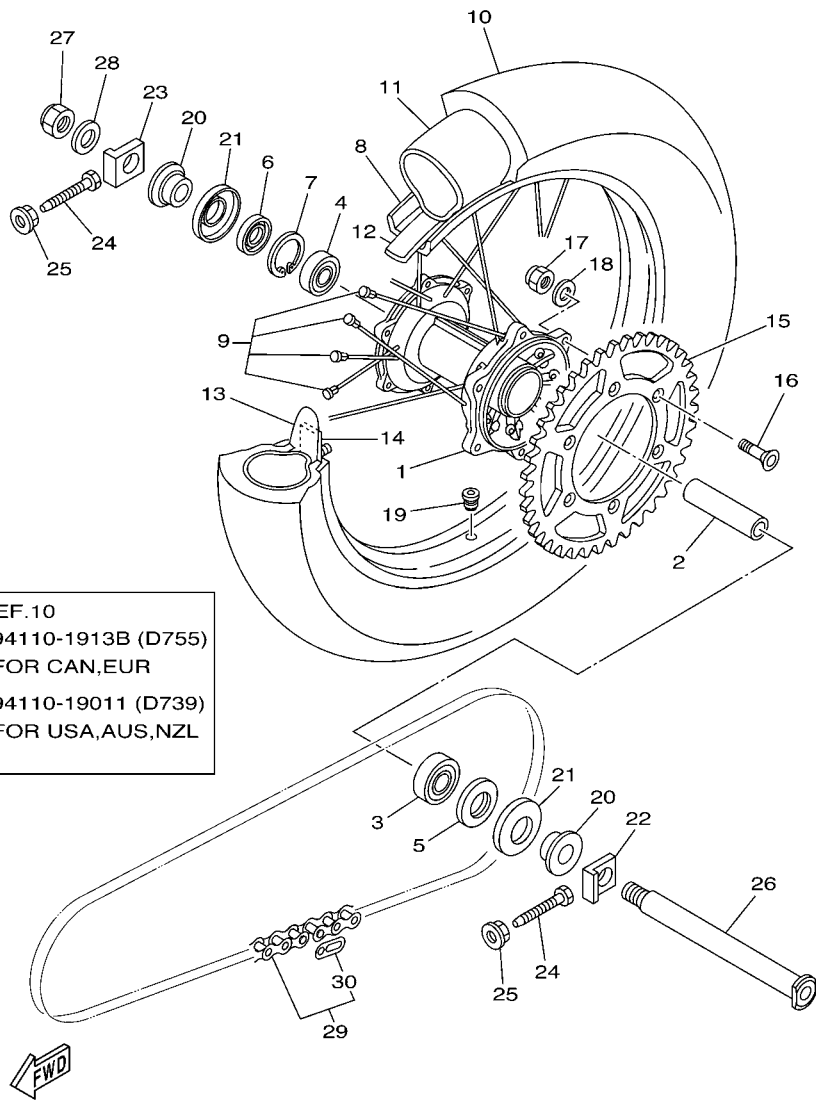

5XE1100-C270

FIG. 27 REAR WHEEL

REF. NO.	PART NO.	DESCRIPTION	5XE1	5XE2	5XE3	5XE4	REMARKS
19	90480-08608	GROMMET	1	1	1	1	
20	5UN-25383-00	COLLAR, WHEEL	2	2	2	2	
21	5ET-25367-00	COVER, HUB DUST	2	2	2	2	
22	5NY-25388-00	PULLER, CHAIN 1	1	1	1	1	
23	5NY-25389-00	PULLER, CHAIN 2	1	1	1	1	
24	90101-08777	BOLT	2	2	2	2	
25	95707-08500	NUT, FLANGE	2	2	2	2	
26	5ET-25381-00	AXLE, WHEEL	1	1	1	1	
27	90185-20168	NUT, SELF-LOCKING	1	1	1	1	
28	90201-203U1	WASHER, PLATE	1	1	1	1	
29	9Y581-92111	CHAIN (DID 520D 112L)	1	1	1	1	
30	94681-68001	.JOINT,CHAIN (DID 520DM-RJ)	1	1	1	1	

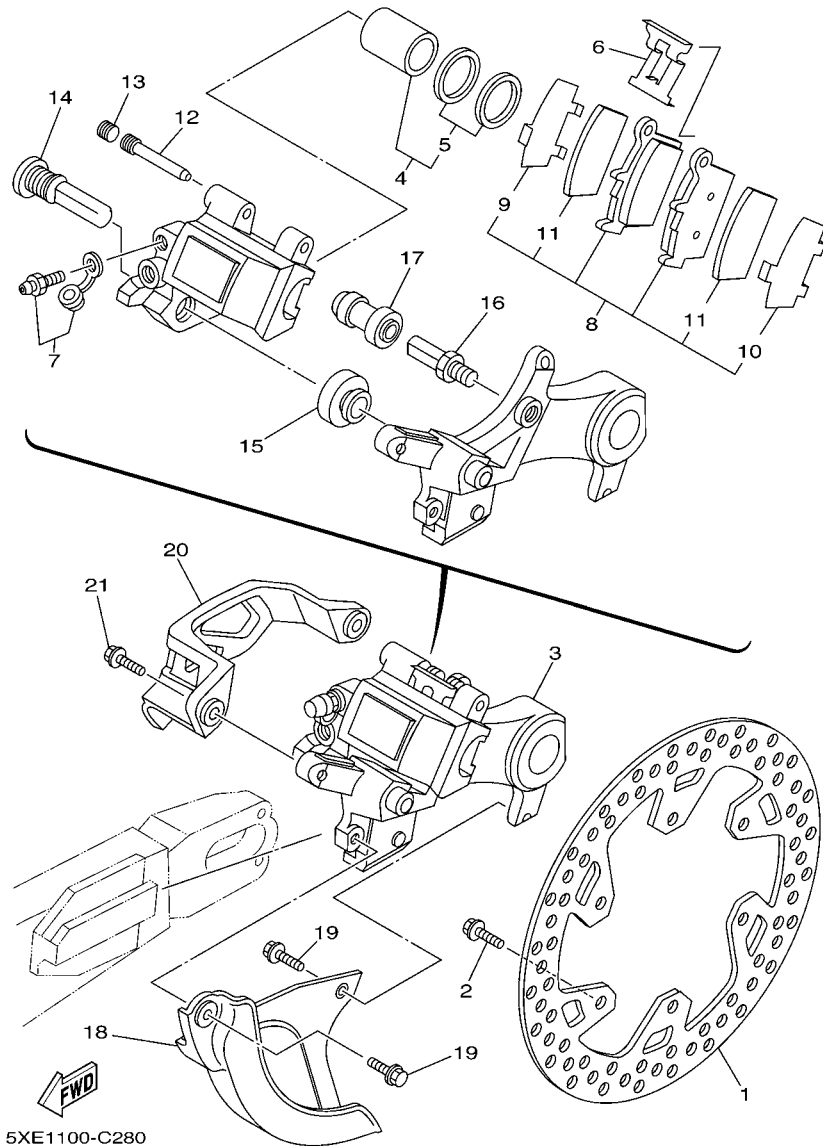

FIG. 28 REAR BRAKE CALIPER

REF. NO.	PART NO.	DESCRIPTION	5XE1	5XE2	5XE3	5XE4	REMARKS
1	5NY-2582W-00	DISC, REAR BRAKE 2	1	1	1	1	
2	90109-065G4	BOLT	6	6	6	6	
3	5UN-2580W-10	CALIPER ASSY, REAR 2	1	1	1	1	
4	5UN-W0057-50	.PISTON ASSY, CALIPER	1	1	1	1	
5	5UN-W0047-50	..CALIPER SEAL KIT	1	1	1	1	
6	5DH-25919-50	..SUPPORT, PAD	1	1	1	1	
7	1UY-W0048-50	.BLEED SCREW KIT	1	1	1	1	
8	5UN-W0046-51	.BRAKE PAD KIT 2	1	1	1	1	
9	5UN-25828-60	..SHIM, CALIPER	1	1	1	1	
10	5UN-25827-60	..SHIM, CALIPER	1	1	1	1	
11	5UN-22898-60	..INSULATOR, HEAT	2	2	2	2	
12	8CR-25924-00	.PIN, PAD	1	1	1	1	
13	5DH-25916-00	.PLUG	1	1	1	1	
14	5DH-25914-50	.PIN, SLIDE	1	1	1	1	
15	3JD-25917-00	.BOOT, CALIPER	1	1	1	1	
16	5UN-25914-00	.PIN, SLIDE	1	1	1	1	
17	1UY-25937-51	.BOOT 2	1	1	1	1	
18	5DH-25718-01	PROTECTOR, DISK BRAKE	1	1	1	1	
19	95027-06012	BOLT, FLANGE	2	2	2	2	
20	5TA-27491-00	PROTECTOR	1	1	1	1	
21	95027-06016	BOLT, FLANGE	2	2	2	2	

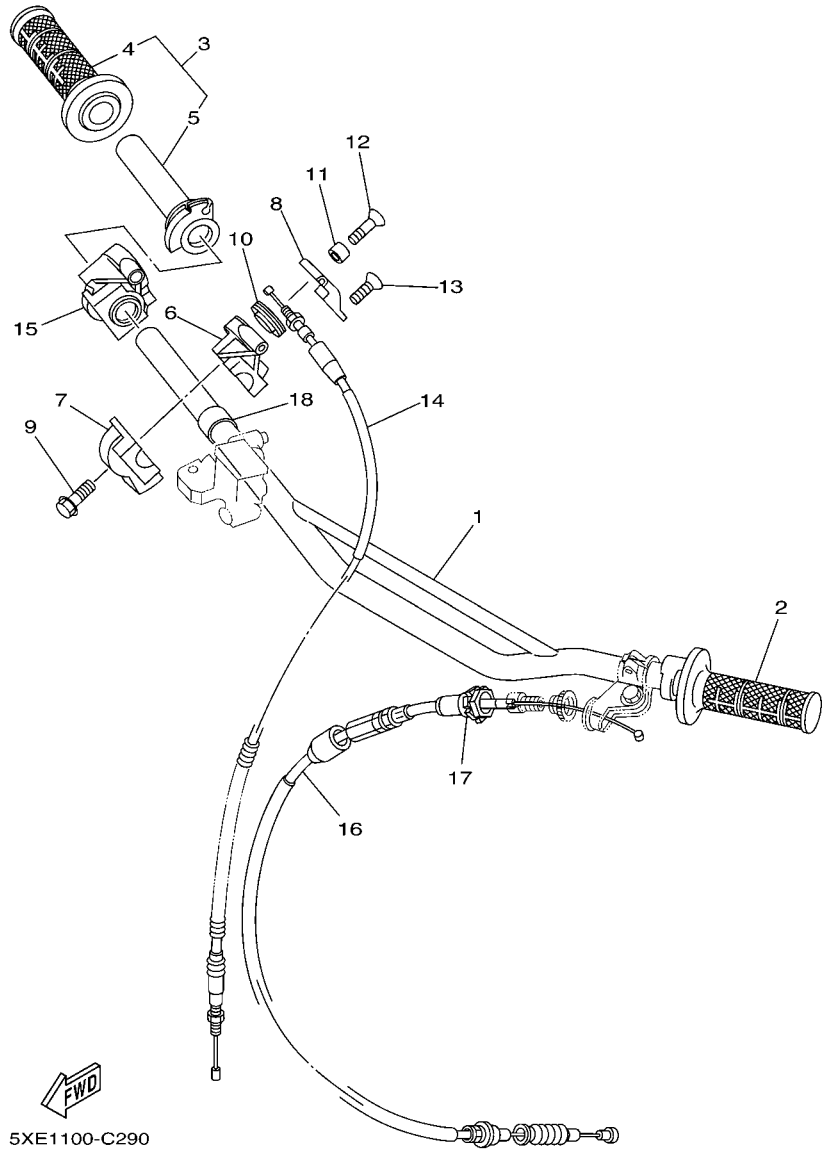
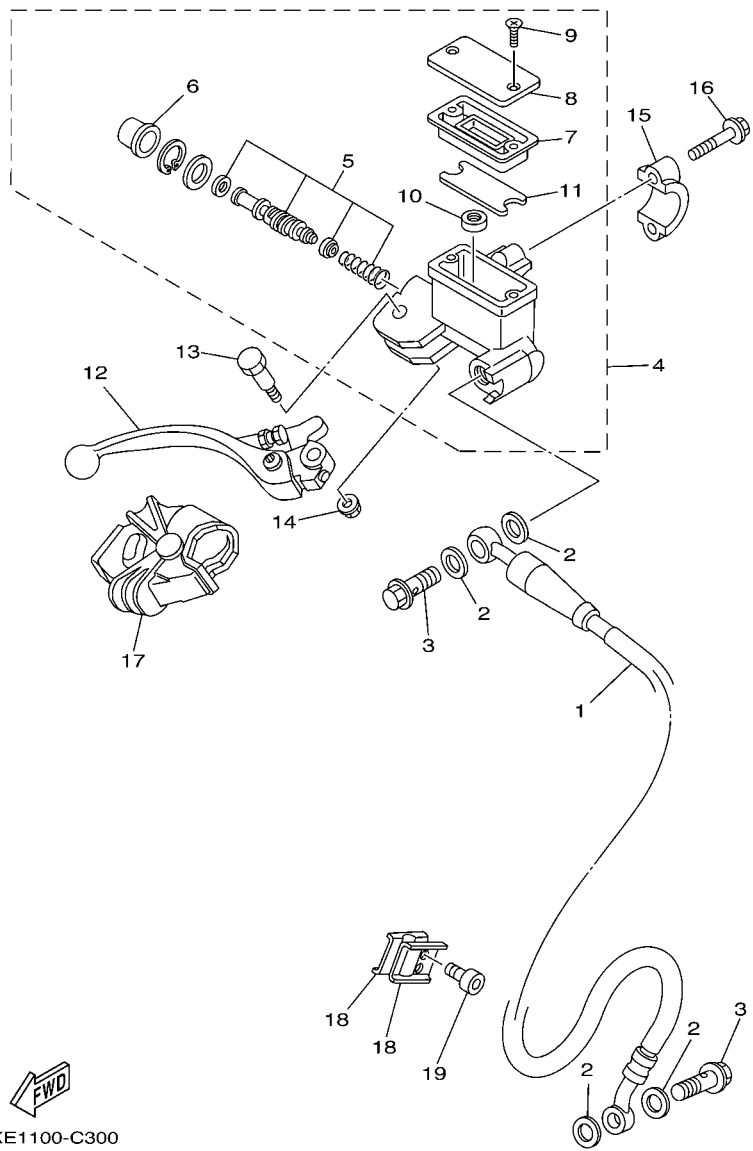

FIG. 29 STEERING HANDLE & CABLE

REF. NO.	PART NO.	DESCRIPTION	5XE1	5XE2	5XE3	5XE4	REMARKS
1	5UN-26111-00	HANDLEBAR	1		1	1	
	4XM-26111-00	HANDLEBAR		1			
2	4GY-26241-00	GRIP	1	1	1	1	
3	4XM-26240-00	GRIP ASSY	1	1	1	1	
4	4GY-26242-00	.GRIP (RIGHT)	1	1	1	1	
5	4XM-26243-00	.TUBE, THROTTLE GUIDE	1	1	1	1	
6	4SS-26281-00	CAP, GRIP UPPER	1	1	1	1	
7	4SS-26282-10	CAP, GRIP LOWER	1	1	1	1	
8	4SS-2628H-00	CAP, WIRE	1	1	1	1	
9	95027-06025	BOLT, FLANGE	2	2	2	2	
10	5NY-26273-00	ROTOR	1	1	1	1	
11	4SS-26259-00	COLLAR	1	1	1	1	
12	4SS-26256-00	SCREW, GRIP END	1	1	1	1	
13	4SS-2632G-00	SCREW	1	1	1	1	
14	5MV-26311-00	CABLE, THROTTLE 1	1	1	1	1	
15	4SS-26287-01	COVER, CAP GRIP	1	1	1	1	
16	5XE-26335-00	CABLE, CLUTCH	1	1	1	1	
17	5HD-26342-00	BOOT, CABLE	1	1	1	1	
18	90387-227H7	COLLAR	1	1	1	1	





5XE1100-C300

FIG. 30 FRONT MASTER CYLINDER

REF. NO.	PART NO.	DESCRIPTION	5XE1	5XE2	5XE3	5XE4	REMARKS
1	5ET-25872-00	HOSE, BRAKE 1	1				
	5HD-25872-00	HOSE, BRAKE 1		1	1	1	
2	90201-10118	WASHER, PLATE	4	4	4	4	
3	90401-10172	BOLT, UNION	2	2	2	2	
4	5XE-W2587-00	MASTER CYLINDER SUB ASSY	1	1	1	1	
5	5NY-W0041-00	.CYLINDER KIT, MASTER	1	1	1	1	
6	5NY-25868-00	.BOOT, MASTER CYLINDER	1	1	1	1	
7	5XE-25854-00	.DIAPHRAGM, RESERVOIR	1	1	1	1	
8	5MV-25852-01	.CAP, RESERVOIR	1	1	1	1	
9	98706-04012	.SCREW, FLAT HEAD	2	2	2	2	
10	5CG-25715-00	.SEPARATOR ASSY	1	1	1	1	
11	5XE-25853-00	.FLOAT, RESERVOIR	1	1	1	1	
12	5MV-83922-00	LEVER 2	1	1	1	1	
13	5MV-2589F-00	BOLT, LEVER	1	1	1	1	
14	95701-06500	NUT, FLANGE	1	1	1	1	
15	5MV-25867-00	BRACKET, MASTER CYLINDER	1	1	1	1	
16	5MV-25833-00	BOLT, FITTING	2	2	2	2	
17	5NY-26372-00	COVER, HANDLE LEVER 1	1	1	1	1	
18	90465-16258	CLAMP	2	2	2	2	
19	91317-06014	BOLT	2	2	2	2	

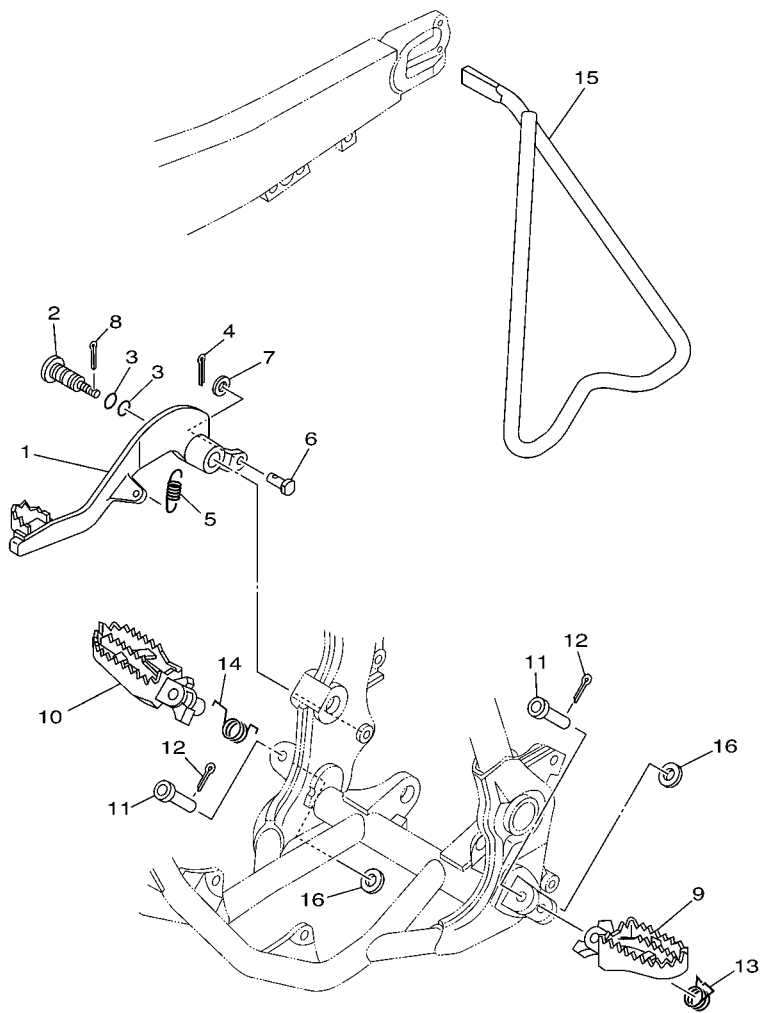
FIG. 31 STAND & FOOTREST



5NY1100-A310

REF. NO.	PART NO.	DESCRIPTION	5XE1	5XE2	5XE3	5XE4	REMARKS
1	4XM-27200-00	PEDAL, BRAKE	1	1	1	1	
2	5JG-27217-00	BOLT	1	1	1	1	
3	93210-11073	O-RING	2	2	2	2	
4	91401-20012	PIN, COTTER	1	1	1	1	
5	90506-16500	SPRING, TENSION	1	1	1	1	
6	90240-08120	PIN, CLEVIS	1	1	1	1	
7	90201-08089	WASHER, PLATE	1	1	1	1	
8	90468-16191	CLIP	1	1	1	1	
9	5XE-27411-00	FOOTREST 1	1	1	1	1	
10	5XE-27421-00	FOOTREST 2	1	1	1	1	
11	90240-10142	PIN, CLEVIS	2	2	2	2	
12	91401-25015	PIN, COTTER	2	2	2	2	
13	90508-282B8	SPRING, TORSION	1	1	1	1	
14	90508-282B9	SPRING, TORSION	1	1	1	1	
15	5ET-27311-00	STAND, SIDE	1	1	1	1	
16	90201-10119	WASHER, PLATE	2	2	2	2	

FIG. 32 REAR MASTER CYLINDER

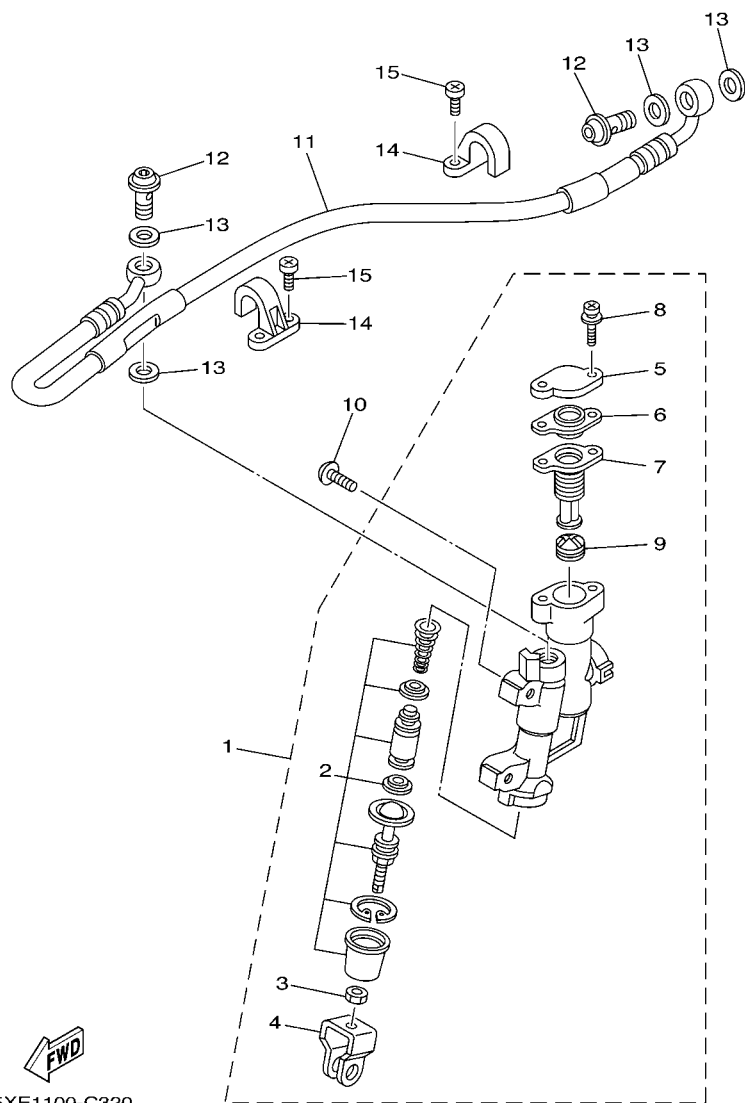

REF. NO.	PART NO.	DESCRIPTION	5XE1	5XE2	5XE3	5XE4	REMARKS
1	5UN-2583V-00	RR. MASTER CYLINDER ASSY.	1	1	1	1	
2	5UN-W0042-50	.CYLINDER KIT, MASTER	1	1	1	1	
3	5UN-27218-00	.NUT	1	1	1	1	
4	5UN-27222-00	.JOINT	1	1	1	1	
5	5UN-25852-50	.CAP, RESERVOIR	1	1	1	1	
6	5UN-2585B-00	.PLATE, DIAPHRAGM	1	1	1	1	
7	5UN-25854-00	.DIAPHRAGM, RESERVOIR	1	1	1	1	
8	5UN-27217-00	.BOLT	2	2	2	2	
9	5CG-25715-00	.SEPARATOR ASSY	2	2	2	2	
10	90111-06029	BOLT	2	2	2	2	
11	5UN-25873-00	HOSE, BRAKE 2	1	1	1	1	
12	90401-10172	BOLT, UNION	2	2	2	2	
13	90201-10118	WASHER, PLATE	4	4	4	4	
14	2VM-25876-00	HOLDER, BRAKE HOSE 2	2	2	2	2	
15	98507-05010	SCREW, PAN HEAD	4	4	4	4	

FIG. 33 GENERATOR

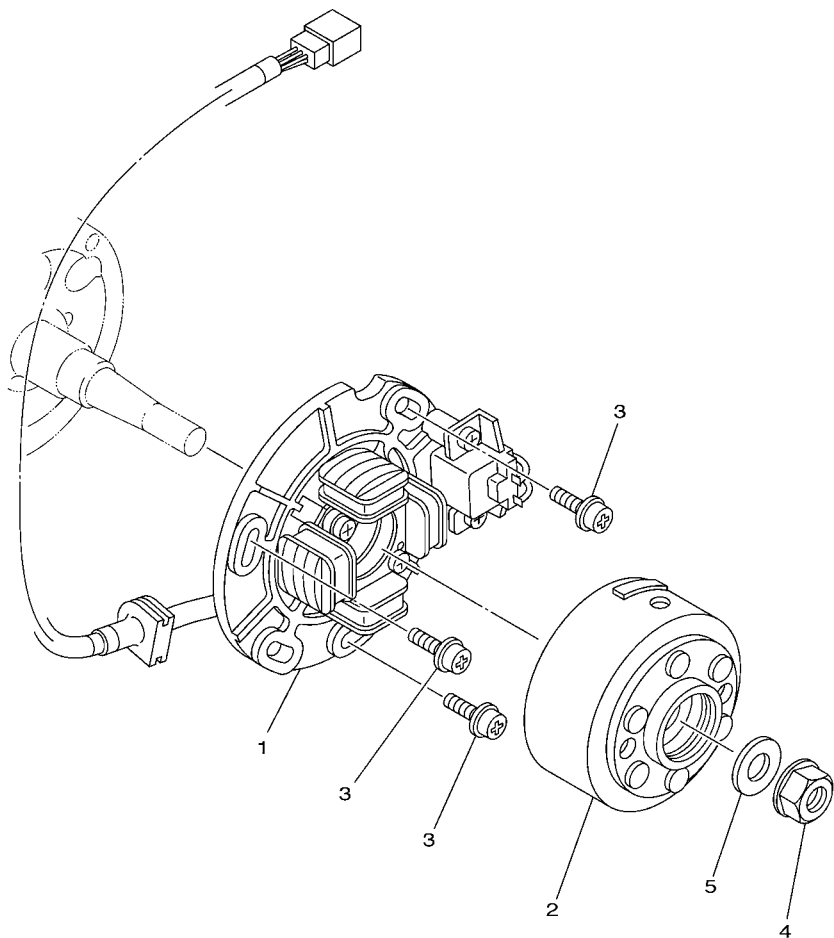

REF. NO.	PART NO.	DESCRIPTION	5XE1	5XE2	5XE3	5XE4	REMARKS
1	4SS-85560-01	BASE ASSY	1	1	1	1	
2	5CU-85550-11	ROTOR ASSY	1	1	1	1	
	5UN-85550-00	ROTOR ASSY	1	1	1	1	AP
3	90149-06011	SCREW	3	3	3	3	
4	90179-10394	NUT	1	1	1	1	
5	90201-10591	WASHER, PLATE	1	1	1	1	

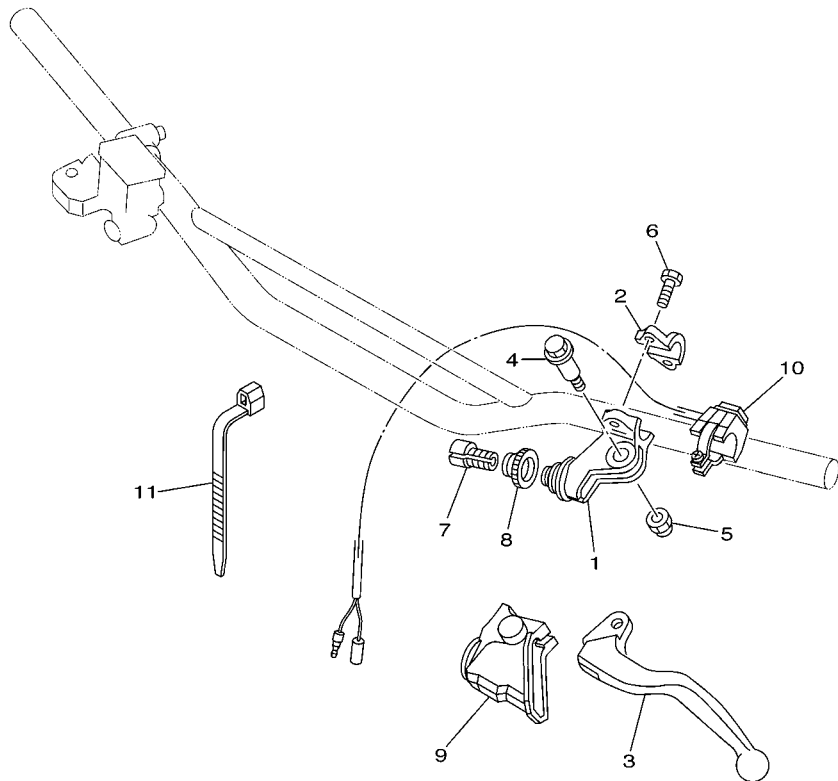

5UN1100-B330

FIG. 34 HANDLE SWITCH & LEVER

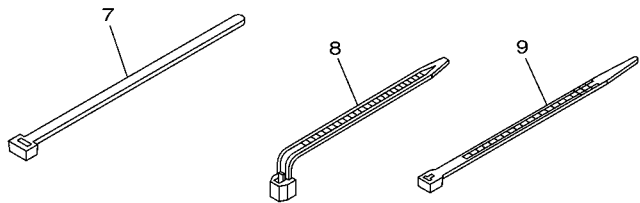
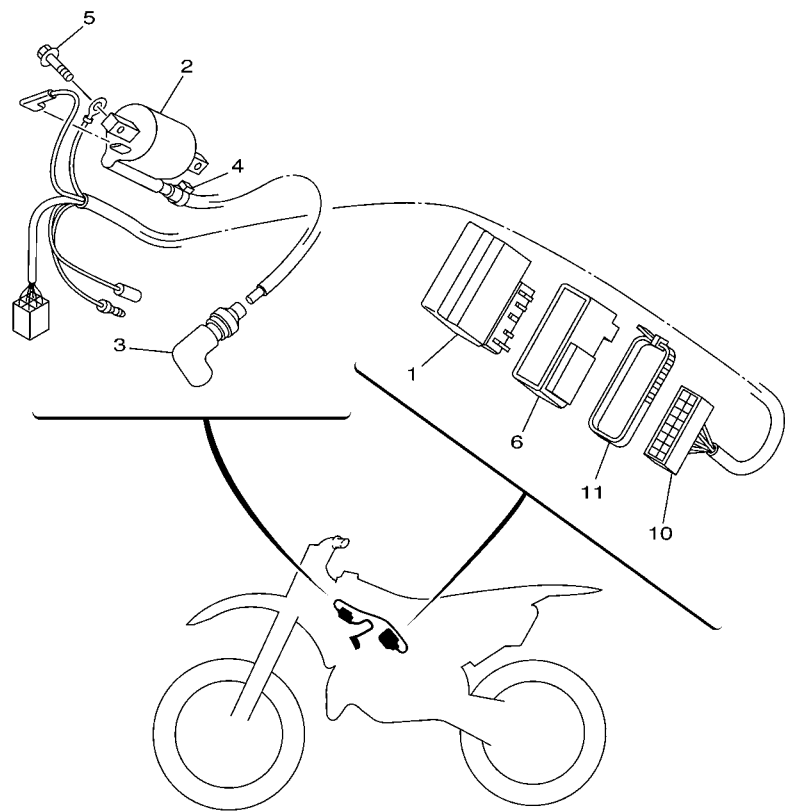

REF. NO.	PART NO.	DESCRIPTION	5XE1	5XE2	5XE3	5XE4	REMARKS
1	5XE-82911-00	HOLDER, LEVER 1	1	1	1	1	
2	5TG-82913-00	HOLDER, LEVER LOWER 1	1	1	1	1	
3	5MV-83912-00	LEVER 1	1	1	1	1	
4	90109-06034	BOLT	1	1	1	1	
5	5LP-84126-10	NUT, LENS FITTING	1	1	1	1	
6	90101-05033	BOLT	2	2	2	2	
7	5TA-26337-00	BOLT, ADJUSTING	1	1	1	1	
8	5HD-83951-00	BOLT, CABLE ADJUSTING	1	1	1	1	
9	5HD-26372-00	COVER, HANDLE LEVER 1	1	1	1	1	
10	23X-83976-00	SWITCH, HANDLE 1	1	1	1	1	
11	90464-13077	CLAMP	2	2	2	2	

5NY1100-A340



5XE1100-C350

FIG. 35 ELECTRICAL 1

REF. NO.	PART NO.	DESCRIPTION	5XE1	5XE2	5XE3	5XE4	REMARKS
1	5NY-85540-11	C.D.I. UNIT ASSY	1	1	1	1	
2	5XE-82310-00	IGNITION COIL ASSY	1	1	1	1	
3	8DG-82370-00	PLUG CAP ASSY	1	1	1	1	
4	90465-10098	CLAMP	1	1	1	1	
5	95027-06016	BOLT, FLANGE	2	2	2	2	
6	5NY-85546-00	BAND	1	1	1	1	
7	90464-50255	CLAMP	2	2	2	2	
8	90464-13073	CLAMP	1	1	1	1	
9	90465-13275	CLAMP	1	1	1	1	
10	5NY-82509-00	WIRE, SUB LEAD	1	1	1	1	
11	90460-15126	CLAMP, HOSE	1	1	1	1	

FIG. 36 ALTERNATE FOR CHASSIS

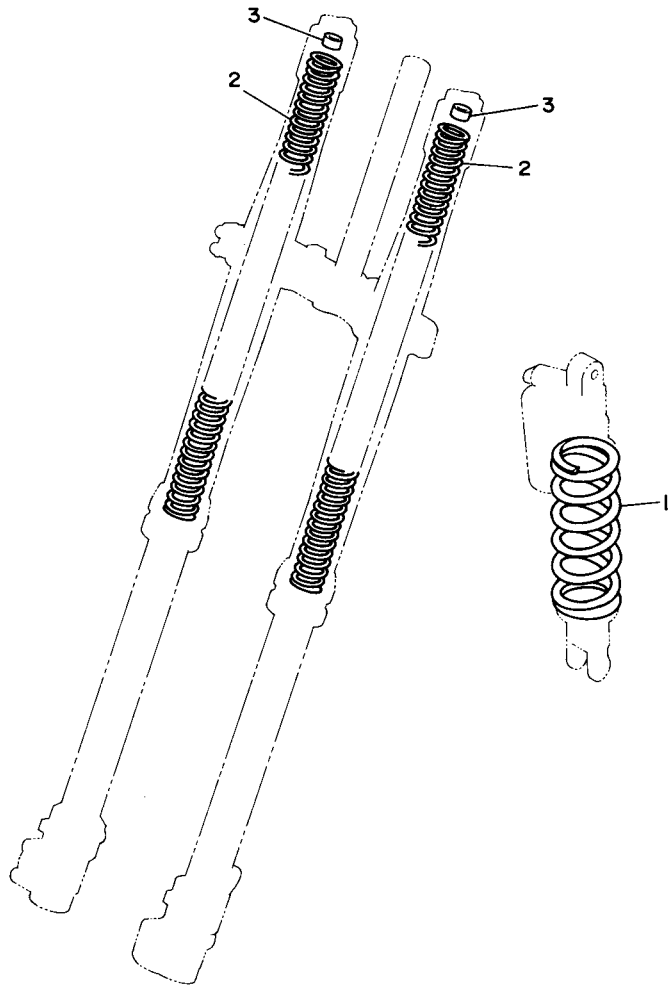

FWD
3XJ1100-1360

REF. NO.	PART NO.	DESCRIPTION	5XE1	5XE2	5XE3	5XE4	REMARKS
1	5UN-22212-00	SPRING (K=42N/MM)	1	1	1	1	AP
	5UN-22212-10	SPRING (K=44N/MM)	1	1	1	1	AP
	5UN-22212-20	SPRING (K=46N/MM)	1	1	1	1	AP
	5UN-22212-30	SPRING (K=48N/MM)	1	1	1	1	AP
	5UN-22212-40	SPRING (K=50N/MM)	1	1	1	1	AP
	5UN-22212-50	SPRING (K=52N/MM)	1	1	1	1	AP
	5UN-22212-60	SPRING (K=54N/MM)	1	1	1	1	AP
	5UN-22212-70	SPRING (K=56N/MM)	1	1	1	1	AP
	5UN-22212-A0	SPRING (K=APPROX.44N/MM)	1	1	1	1	AP
	5UN-22212-B0	SPRING (K=APPROX.46N/MM)	1	1	1	1	AP
	5UN-22212-C0	SPRING (K=APPROX.48N/MM)	1	1	1	1	AP
	5UN-22212-D0	SPRING (K=APPROX.50N/MM)	1	1	1	1	AP
	5UN-22212-E0	SPRING (K=APPROX.52N/MM)	1	1	1	1	AP
5UN-22212-F0	SPRING (K=APPROX.54N/MM)	1	1	1	1	AP	
5UN-22212-G0	SPRING (K=APPROX.56N/MM)	1	1	1	1	AP	
2	5XE-23141-00	SPRING (K=3.9N/MM)	2	2	2	2	AP
	5XE-23141-10	SPRING (K=4.0N/MM)	2	2	2	2	AP
	5XE-23141-20	SPRING (K=4.1N/MM)	2	2	2	2	AP
	5XE-23141-30	SPRING (K=4.2N/MM)	2	2	2	2	AP
	5XE-23141-40	SPRING (K=4.3N/MM)	2	2	2	2	AP
	5XE-23141-50	SPRING (K=4.4N/MM)	2	2	2	2	AP
	5XE-23141-60	SPRING (K=4.5N/MM)	2	2	2	2	AP
	5XE-23141-70	SPRING (K=4.6N/MM)	2	2	2	2	AP
	5XE-23141-80	SPRING (K=4.7N/MM)	2	2	2	2	AP
	5XE-23141-A0	SPRING (K=APPROX.3.9N/MM)	2	2	2	2	AP
5XE-23141-B0	SPRING (K=APPROX.4.1N/MM)	2	2	2	2	AP	
5XE-23141-C0	SPRING (K=APPROX.4.3N/MM)	2	2	2	2	AP	

E4

FIG. 36 ALTERNATE FOR CHASSIS

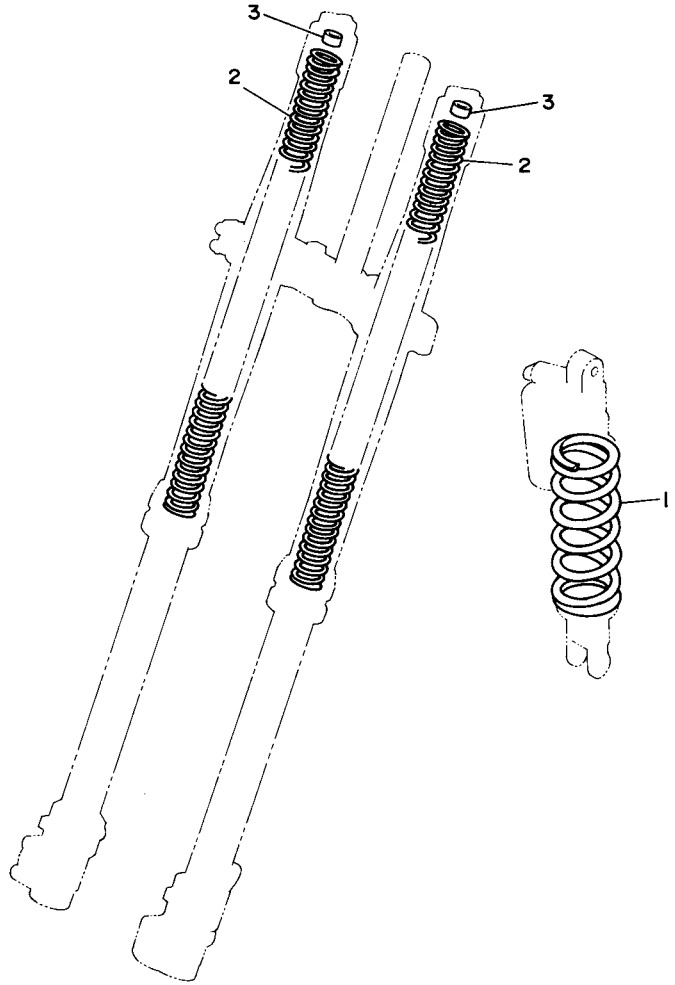

REF. NO.	PART NO.	DESCRIPTION	5XE1	5XE2	5XE3	5XE4	REMARKS
2	5XE-23141-D0	SPRING (K=APPROX.4.5N/MM)	2	2	2	2	AP
	5XE-23141-E0	SPRING (K=APPROX.4.7N/MM)	2	2	2	2	AP
3	5XE-23364-00	COLLAR 2	1	1	1	1	UN

FWD
3XJ1100-1360

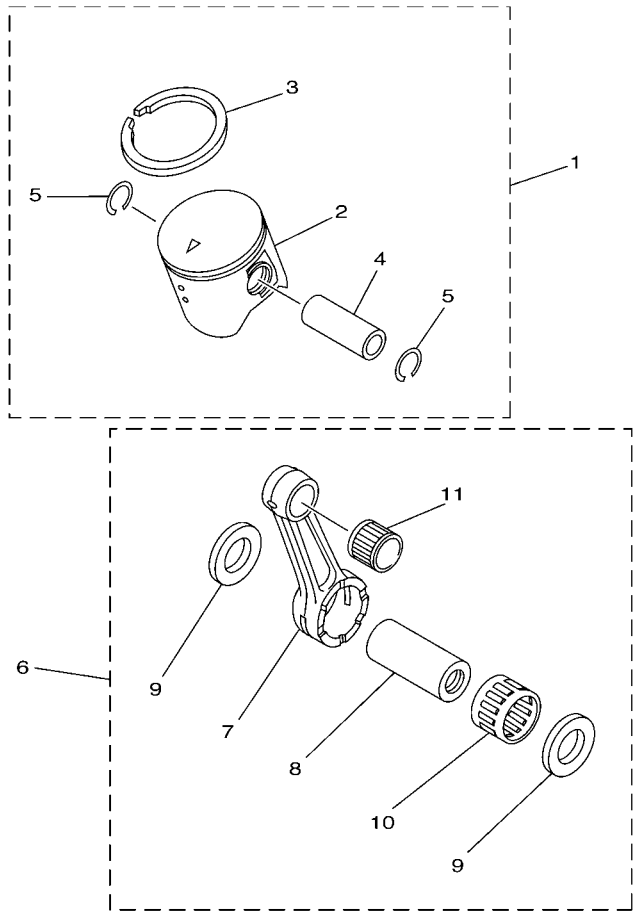

5NY1100-A370

FIG. 37 OPTIONAL PARTS 1

REF. NO.	PART NO.	DESCRIPTION	5XE1	5XE2	5XE3	5XE4	REMARKS
1	5NY-11630-01	PISTON ASSY (STD)	1	1	1	1	
2	5NY-11631-01-B0	.PISTON (STD)	1	1	1	1	ORANGE
3	5NY-11611-00	.RING, PISTON	1	1	1	1	
4	5UN-11633-00	.PIN, PISTON	1	1	1	1	
5	93450-16068	.CIRCLIP	2	2	2	2	
6	5MV-11650-00	CONNECTING ROD ASSY	1	1	1	1	
7	5MV-11651-00	.ROD, CONNECTING	1	1	1	1	
8	3JD-11681-10	.PIN, CRANK 1	1	1	1	1	
9	90209-22071	.WASHER	2	2	2	2	
10	93310-522P7	.BEARING	1	1	1	1	
11	93310-21510	.BEARING	1	1	1	1	

NUMERICAL INDEX

PART NO.	GRID NO.	PART NO.	GRID NO.	PART NO.	GRID NO.	PART NO.	GRID NO.	PART NO.	GRID NO.	PART NO.	GRID NO.
5UN-11111-00	B - 2	5NY-12482-00	B - 7	137-14143-88	B - 10	4JY-15462-00	B - 14	5XE-21190-00	C - 7	5UN-22212-10	C - 12
4JY-11166-00	B - 2	5NY-12483-01	B - 7	137-14143-90	B - 10	4JY-15463-10	B - 14	5UN-21274-00	C - 7		E - 4
5XE-11311-00	B - 2	5NY-12484-00	B - 7	51R-14146-00	B - 11	5NY-15490-00	B - 14	5HD-2135F-00	C - 11	5UN-22212-20	E - 4
5HD-1131D-20	B - 2	353-13115-01	B - 13	5MV-14146-00	B - 11	4DB-15620-03	B - 15	5XE-2135F-00	C - 11	5UN-22212-30	E - 4
4SS-1131M-00	B - 2	5UN-13565-00	B - 8	2K6-14147-00	B - 9	4DB-15621-03	B - 15	5NY-21425-00	C - 7	5UN-22212-40	E - 4
5HD-1131V-00	B - 2	5UN-13610-00	B - 8	5ET-14147-00	B - 11	1LX-15641-00	B - 15	5HD-21511-00	C - 8	5UN-22212-50	E - 4
5HD-1132D-20	B - 2	5UN-13613-00	B - 8	3MA-14159-00	B - 9	1LX-15651-00	B - 15	5UN-2153A-00	C - 11	5UN-22212-60	E - 4
5MV-11351-01	B - 2	5MV-13616-00	B - 8	5ET-1416A-00	B - 11	1LX-15660-03	B - 15	4XL-2153A-10	D - 2	5UN-22212-70	E - 4
4JY-11354-10	B - 2	5MV-13625-00	B - 8	3JE-14171-00	B - 9	3XJ-16111-00	C - 2	4ES-2153E-01	C - 8	5UN-22212-A0	E - 4
5UN-11395-00	B - 2	5XE-14101-00	B - 9	5NY-14181-00	B - 11	5NY-16150-00	C - 2	5XE-21610-00	C - 8	5UN-22212-B0	C - 12
5MV-11400-00	B - 5	5XE-14101-10	B - 9	5ET-14185-00	B - 9	3XJ-16181-00	C - 2	5XE-21635-00	C - 8		E - 4
5MV-11410-00	B - 5	4PE-14103-00	B - 9	353-14186-00	B - 9	3XJ-16321-00	C - 2	5XE-2163G-00	C - 8	5UN-22212-C0	E - 4
5MV-11420-00	B - 5	3JD-14104-00	B - 9	4PE-14194-00	B - 9	5DH-16321-00	C - 2	5TA-21642-00	C - 8	5UN-22212-D0	E - 4
5NY-11611-00	B - 5	4PE-14107-38	B - 9	5MV-14194-00	B - 11	3XJ-16324-01	C - 2	5NY-21711-00	C - 9	5UN-22212-E0	E - 4
	E - 6	5NY-14112-37	B - 11	10V-14196-00	B - 9	3JD-16340-00	C - 2	5GJ-21717-00	C - 7	5UN-22212-F0	E - 4
5NY-11630-01	E - 6	5NY-14112-40	B - 11	2HH-14197-00	B - 11	5HD-16351-00	C - 2	5NY-21721-00	C - 9	5UN-22212-G0	E - 4
5NY-11631-01-A0	B - 5	5NY-14112-42	B - 11	5ET-14197-00	B - 9	3SB-16356-10	C - 2	5NL-2172A-11	C - 9	3SP-22213-00	C - 12
5NY-11631-01-B0	B - 5	5ET-14115-00	B - 9	5MV-14216-00	B - 11	5NY-16371-00	C - 2	5XE-21730-00	C - 9	5XE-22214-00	C - 12
	E - 6	284-14116-E3	B - 9	5HD-14261-00	B - 9	4EX-16382-10	B - 14	5XE-2173E-00	C - 9	5MV-22224-00	C - 12
5NY-11631-01-C0	B - 5	284-14116-E4	B - 9	5MV-14261-00	B - 11	5UN-17121-00	C - 3	5XE-2173F-00	C - 9	4JX-22226-00	C - 12
5NY-11631-01-D0	B - 5	284-14116-E5	B - 9	5ET-14261-01	B - 9	5NY-17131-00	C - 3	5XE-21740-00	C - 9	3SP-22234-00	C - 12
5UN-11633-00	B - 5	284-14116-E6	B - 9	5NY-14401-01	B - 8	5NY-17141-00	C - 3	3JD-21748-00	C - 8	5NY-22241-00	C - 13
	E - 6	284-14116-E7	B - 9	5NY-14417-00	B - 8	5NY-17151-00	C - 3	5MV-2175C-00	C - 9	5XE-22242-00	C - 12
5MV-11650-00	E - 6	284-14116-E8	B - 10	5NY-14442-00	B - 8	5UN-17211-00	C - 3	5UN-22110-00	C - 10	5DH-22253-00	C - 12
5MV-11651-00	B - 5	284-14116-E9	B - 10	4XM-14451-00	B - 8	5UN-17221-00	C - 3	5NY-22121-00	C - 10	5MV-22253-00	C - 12
	E - 6	284-14116-F3	B - 10	5NX-14453-00	B - 8	5NY-17231-00	C - 3	5XE-22122-00	C - 11	5UN-22355-00	C - 10
3JD-11681-10	B - 5	284-14116-F4	B - 10	5NY-14455-10	B - 8	5NY-17241-00	C - 3	5UN-22128-00	C - 10	4EW-22474-00	C - 12
	E - 6	284-14116-F5	B - 9	3JD-14458-01	B - 8	5NY-17251-00	C - 3	5NY-22141-01	C - 10	3JE-22475-00	C - 12
4SS-11832-00	B - 2	284-14116-F6	B - 9	5NY-14459-00	B - 8	5UN-17411-00	C - 3	5UN-22151-00	C - 10	5NY-22475-00	C - 12
5CU-11911-00	B - 4	284-14116-F7	B - 10	1FN-14565-00	B - 9	5NY-17421-00	C - 3	5JG-22156-00	C - 10	5UN-22898-60	D - 10
5CU-11912-00	B - 4	284-14116-F8	B - 10	5NY-14610-00	B - 12	4SS-18101-10	C - 6	5MV-22176-00	C - 12	5XE-23102-00	C - 15
4JY-11915-01	B - 4	284-14116-F9	B - 10	5NY-14610-20	B - 12	5XE-18110-00	C - 6	4EW-22178-00	C - 7	5XE-23102-10	C - 15
5X4-11921-02	B - 4	4PE-14131-00	B - 9	4JY-14615-00	B - 12	5MV-18122-00	C - 6	3JD-22178-10	C - 7	5XE-23102-20	C - 15
3JE-11922-01	B - 4	87M-14137-00	B - 11	5MV-14642-00	B - 12	5HD-18140-00	C - 5	5NY-2217A-00	C - 10	5XE-23103-00	C - 15
5CU-11952-00	B - 4	4KM-14142-30	B - 10	5NY-1469A-00	B - 12	4JY-18172-00	C - 6	5XE-2217F-00	C - 11	5XE-23103-10	C - 15
5NY-11953-00	B - 4	4KM-14142-32	B - 10	5XE-14753-00	B - 12	3XJ-18173-00	C - 6	5MV-22184-00	C - 12	5XE-23103-20	C - 15
4SS-11990-00	B - 4	4KM-14142-35	B - 10	565-14771-00	B - 12	3XJ-18178-00	C - 6	5UN-22199-00	C - 10	5XE-23110-L0	C - 15
4JY-11991-01	B - 3	4KM-14142-37	B - 10	5CU-14771-00	B - 12	3XJ-18182-00	C - 6	5XE-22201-00	C - 12	5XE-23111-L0	C - 15
4JY-11993-01	B - 3	4KM-14142-40	B - 10	5NY-15111-01	B - 13	3XJ-18184-00	C - 6	5XE-22201-10	C - 12	5XE-23113-00	D - 2
4JY-11995-00	B - 3	4KM-14142-42	B - 10	3R4-15118-00	B - 13	4EW-18185-00	C - 6	5XE-22201-20	C - 12	5XE-23117-L0	C - 15
5NY-1240A-00	B - 7	4KM-14142-45	B - 10	5NY-15121-01	B - 13	5NY-18511-00	C - 5	5XE-22201-30	C - 12	5XE-23120-L0	C - 15
4JY-12422-01	B - 6	4KM-14142-47	B - 10	3Y1-15363-00	B - 14	5NY-18512-00	C - 5	5XE-22201-40	C - 12	5XE-23125-L0	C - 15
4JY-12428-10	B - 6	4KM-14142-50	B - 10	1LX-15383-00	C - 3	5NY-18513-00	C - 5	5XE-22210-00	C - 12	3JD-2312G-L0	C - 15
5DH-12451-00	B - 6	137-14143-78	B - 10	4XM-15383-00	C - 3	4EX-18531-00	C - 5	5XE-22210-10	C - 12	5XE-23136-L0	C - 15
5DH-12459-01	B - 6	137-14143-80	B - 10	4JY-15411-00	B - 14	4EX-18535-00	C - 5	5XE-22210-20	C - 12	5XE-23141-00	E - 4
5NY-12461-00	B - 7	137-14143-82	B - 10	4EX-15421-00	B - 14	5NY-18541-00	C - 5	5XE-22210-30	C - 12	5XE-23141-10	E - 4
5HD-12462-00	B - 7	137-14143-84	B - 10	4JY-15431-14	B - 14	5DH-18562-00	C - 5	5XE-22210-40	C - 12	5XE-23141-20	E - 4
5NY-12481-00	B - 7	137-14143-86	B - 10	4JY-15451-10	B - 14	5XE-21101-00	C - 7	5UN-22212-00	E - 4	5XE-23141-30	E - 4

NUMERICAL INDEX

PART NO.	GRID NO.	PART NO.	GRID NO.	PART NO.	GRID NO.	PART NO.	GRID NO.	PART NO.	GRID NO.	PART NO.	GRID NO.
5XE-23141-40	E - 4	5NY-24182-00	D - 4	5MV-25852-01	D - 12	4XM-27200-00	D - 13	90105-10445	C - 2	90201-06060	B - 15
5XE-23141-50	E - 4	5XE-24183-00	D - 4	5UN-25852-50	D - 14	5JG-27217-00	D - 13	90105-10733	C - 7	90201-06071	B - 12
5XE-23141-60	E - 4	5NY-24186-00	D - 4	5XE-25853-00	D - 12	5UN-27217-00	D - 14	90109-06034	E - 2		C - 8
5XE-23141-70	E - 4	5XE-24240-00	D - 4	5UN-25854-00	D - 14	5UN-27218-00	D - 14	90109-06418	B - 14	90201-062A8	C - 8
5XE-23141-80	E - 4	3XJ-24380-00	D - 4	5XE-25854-00	D - 12	5UN-27222-00	D - 14	90109-065G4	D - 10	90201-06557	C - 8
5XE-23141-A0	E - 4	3JD-24500-01	D - 4	5UN-2585B-00	D - 14	5ET-27311-00	D - 13	90109-067F4	B - 8	90201-06571	B - 7
5XE-23141-B0	E - 4	4X8-24512-00	D - 4	5MV-25867-00	D - 12	5XE-27411-00	D - 13	90109-081G1	D - 8	90201-08089	D - 13
5XE-23141-C0	E - 4	5MV-24514-00	B - 11	5NY-25868-00	D - 12	5XE-27421-00	D - 13	90111-06029	D - 14	90201-080L8	B - 2
5XE-23141-D0	E - 5	3AJ-24534-00	D - 4	5ET-25872-00	D - 12	5TA-27491-00	D - 10	90111-08010	C - 7	90201-08326	D - 8
5XE-23141-E0	E - 5	5NY-24610-00	D - 4	5HD-25872-00	D - 12	5ET-28166-00	C - 7	90116-08318	B - 2	90201-083P5	B - 6
5XE-23141-80	C - 15	5XE-2470F-00	D - 4	5UN-25873-00	D - 14	5XE-82310-00	E - 3	90116-08388	B - 2	90201-086P8	C - 7
5XE-23142-L0	C - 15	5NY-24728-00	D - 5	5DH-25875-00	D - 7	8DG-82370-00	E - 3	90116-08394	B - 2	90201-08730	C - 7
5XE-23144-L0	C - 15	5XE-24770-00	D - 5	2VM-25876-00	D - 14	5NY-82509-00	E - 3	90119-06096	C - 8	90201-08759	C - 2
5XE-23145-L0	C - 15	5NY-25104-00	D - 6	5MV-2589F-00	D - 12	5XE-82911-00	E - 2	90119-06192	B - 12	90201-08784	B - 6
5XE-23146-L0	C - 15	5NY-25111-00	D - 6	5UN-25914-00	D - 10	5TG-82913-00	E - 2	90119-06225	C - 8	90201-10118	D - 12
5DH-2314E-00	D - 7	5NY-25117-00	D - 6	5DH-25914-50	D - 10	5MV-83912-00	E - 2		C - 14		D - 14
5XE-2314F-L0	D - 2	5BE-25181-00	D - 6	3SP-25914-51	D - 7	5MV-83922-00	D - 12	90119-08238	C - 9	90201-10119	D - 13
5XE-2314G-L0	D - 2	5NY-25183-00	D - 6	5DH-25916-00	D - 7	5HD-83951-00	E - 2	90122-06035	B - 8	90201-10591	D - 15
5TA-2314H-00	D - 2	5NY-25186-00	D - 6		D - 10	23X-83976-00	E - 2	90149-06011	D - 4	90201-14740	C - 11
5TA-2314J-00	D - 2	5HD-25304-00	D - 8	3JD-25917-00	D - 7	5LP-84126-10	E - 2		D - 15	90201-150U6	B - 4
5XE-23153-L0	C - 15	5ET-25311-00	D - 8		D - 10	5NY-85540-11	E - 3	90149-06327	D - 7	90201-152H7	B - 15
4SS-23158-L0	C - 15	5ET-25317-00	D - 8	5DH-25919-00	D - 7	5NY-85546-00	E - 3	90151-04001	C - 10	90201-15700	C - 3
5XE-2316A-L0	C - 15	4XM-25364-00	D - 8	5DH-25919-50	D - 10	5UN-85550-00	D - 15	90151-06037	C - 3	90201-160F6	C - 10
5XE-2316A-M0	C - 15	5ET-25367-00	D - 9	8CR-25924-00	D - 10	5CU-85550-11	D - 15	90152-06010	B - 15	90201-171G4	B - 15
5XE-23170-L0	C - 15	5ET-25381-00	D - 9	3SP-25926-51	D - 7	4SS-85560-01	D - 15	90159-06016	C - 2	90201-203U1	D - 9
5XE-23171-L0	C - 15	5UN-25383-00	D - 9	5DH-25933-00	D - 7	5NY-W0041-00	D - 12	90159-06078	C - 5	90201-20611	C - 2
5DH-23183-00	C - 12	5NY-25388-00	D - 9	1UY-25937-51	D - 7	5UN-W0042-50	D - 14		C - 9		C - 3
509-23184-L0	C - 12	5NY-25389-00	D - 9		D - 10	5MV-W0045-01	D - 7	90159-06182	C - 9	90201-22555	C - 3
5XE-23340-L0	D - 2	4XM-25394-00	D - 8	4XM-26111-00	D - 11	5UN-W0046-51	D - 10	90170-16326	C - 2	90201-22793	C - 3
4SS-23346-L0	D - 2	5SF-25394-00	D - 6	5UN-26111-00	D - 11	3JD-W0047-00	D - 7	90176-08026	B - 2	90201-247L2	C - 14
5NY-23346-L0	D - 2	5ET-25447-00	D - 8	4XM-26240-00	D - 11	5UN-W0047-50	D - 10	90179-06568	C - 10	90201-286K9	C - 14
3SP-23356-L0	D - 2	5NY-25448-00	D - 8	4GY-26241-00	D - 11	1UY-W0048-50	D - 7	90179-08299	B - 2	90202-05193	D - 4
5TA-23357-00	C - 14	5NY-25449-00	D - 8	4GY-26242-00	D - 11		D - 10	90179-08674	C - 7	90209-06096	B - 8
5XE-23364-00	E - 5	5NY-25450-00	D - 8	4XM-26243-00	D - 11	5UN-W0057-00	D - 7	90179-10394	D - 15	90209-18135	C - 3
5XE-23389-00	D - 2	5NY-25451-00	D - 8	4SS-26256-00	D - 11	5UN-W0057-50	D - 10	90179-10658	C - 7	90209-22071	B - 5
5XE-23393-L0	C - 15	5NY-25452-00	D - 8	4SS-26259-00	D - 11	5XE-W2587-00	D - 12	90179-16226	C - 4		E - 6
5HD-2339E-00	C - 14	5CG-25715-00	D - 12	5NY-26273-00	D - 11	90101-05033	E - 2	90179-16672	D - 6	90215-16289	C - 2
4EW-23416-00	C - 14		D - 14	4SS-26281-00	D - 11	90101-06664	C - 6	90179-28003	C - 14	90215-20261	C - 4
5XE-23435-00	C - 14	5DH-25718-01	D - 10	4SS-26282-10	D - 11	90101-08777	D - 9	90183-06023	B - 8	90240-08120	D - 13
5XE-23435-10	C - 14	5UN-2580T-00	D - 7	4SS-26287-01	D - 11	90105-06045	C - 8	90185-08055	C - 7	90240-10142	D - 13
5XE-23441-00	C - 14	5UN-2580W-10	D - 10	4SS-2628H-00	D - 11	90105-06046	C - 8	90185-08169	D - 8	90267-32070	B - 8
5HD-23485-10	C - 14	5MV-2581T-00	D - 7	5MV-26311-00	D - 11	90105-06553	C - 5	90185-10060	C - 13	90280-03017	B - 5
5XE-24110-00	D - 4	5UN-25827-60	D - 10	4SS-2632G-00	D - 11	90105-06556	B - 13	90185-14007	C - 11	90338-21145	C - 7
4EW-2412F-00	D - 4	5UN-25828-60	D - 10	5XE-26335-00	D - 11	90105-08058	C - 7	90185-16127	C - 10	90338-30256	C - 7
5XE-24144-00	D - 4	5NY-2582W-00	D - 10	5TA-26337-00	E - 2	90105-08059	C - 7	90185-20168	D - 9	90340-12059	B - 13
3SP-24173-00	D - 4	5MV-25833-00	D - 12	5HD-26342-00	D - 11	90201-08120	C - 7	90201-03313	B - 8	90387-06009	C - 8
5XE-24176-00	D - 4	5UN-2583V-00	D - 14	5HD-26372-00	E - 2	90105-08659	D - 7	90201-057H5	B - 4	90387-06039	B - 12
4SS-24181-00	D - 4	5DH-25849-00	D - 7	5NY-26372-00	D - 12	90105-10073	C - 7	90201-06060	B - 12	90387-06065	B - 7

NUMERICAL INDEX

PART NO.	GRID NO.	PART NO.	GRID NO.	PART NO.	GRID NO.	PART NO.	GRID NO.	PART NO.	GRID NO.	PART NO.	GRID NO.
90387-062W7	B - 12	90480-16561	B - 12	93109-20076	C - 10	9383A-14054	C - 4	95707-08500	D - 9		
90387-063F7	C - 5	90480-18549	D - 4	93109-28043	C - 10	94108-21012	D - 6	95827-06010	B - 7		
90387-063G3	B - 12	90501-052G5	C - 6	93210-11073	D - 13	94108-21015	D - 6	95827-06012	D - 7		
90387-085E1	B - 4	90501-12081	B - 15	93210-15171	B - 15	94108-2112Y	D - 6	95827-06016	C - 9		
90387-086N4	C - 7	90501-23391	C - 2	93210-16314	B - 13	94110-19009	D - 8	97007-05012	B - 4		
90387-08785	B - 3	90501-30001	B - 4	93210-19123	B - 14	94110-19011	D - 8	97007-05016	B - 3		
90387-107T9	B - 4	90506-16500	D - 13	93210-63442	B - 2	94110-1913B	D - 8	97027-06012	B - 15		
90387-152F2	B - 4	90507-20052	B - 12	93210-90785	B - 2	94209-21229	D - 6	97307-06012	D - 5		
90387-16005	C - 10	90508-141B4	C - 2	93300-60801	B - 4	94210-19222	D - 8	97707-60016	C - 8		
90387-16007	C - 10	90508-16134	B - 3	93300-60804	C - 7	94210-19224	D - 8	97801-03008	D - 4		
90387-167Y9	C - 10	90508-261B7	C - 5	93306-00105	B - 6	94227-21101	D - 6	98502-05014	B - 11		
90387-18004	C - 10	90508-26450	B - 15	93306-07202	D - 8	94309-21161	D - 6	98507-03006	B - 8		
90387-18005	C - 10	90508-282B8	D - 13	93306-20431	C - 3	94316-19156	D - 8	98507-04008	B - 9		
90387-18007	B - 13	90508-282B9	D - 13	93306-27205	D - 8	94321-19135	D - 8	98507-04014	B - 9		
90387-20007	C - 2	90508-295A7	C - 6	93306-30411	C - 3	94330-21084	D - 6	98507-05010	D - 14		
90387-202A0	C - 4	90560-12280	C - 6	93306-37204	B - 5	94416-21003	D - 6	98507-05012	B - 4		
90387-227H7	D - 11	90560-17279	B - 15	93306-90403	D - 6	94418-19601	D - 8	98507-06016	B - 14		
90401-10172	D - 12	91317-04006	B - 4	93306-90506	C - 5	94681-68001	D - 9	98507-06030	B - 14		
	D - 14	91317-04010	B - 2	93310-21510	B - 5	94702-00324	B - 2	98706-04012	D - 12		
90430-06014	B - 6	91317-05008	C - 10		E - 6	94709-00324	B - 2	98707-06025	D - 4		
	B - 14	91317-05012	B - 2	93310-225N0	C - 2	95027-06010	B - 6	98907-05016	B - 2		
90430-12227	B - 13	91317-06014	D - 12	93310-522P7	B - 5		B - 14	98907-06025	D - 4		
90445-08605	B - 13	91317-06045	B - 13		E - 6		C - 10	99001-06600	B - 6		
90445-09104	D - 4	91317-06055	B - 13	93311-31515	C - 4	95027-06012	B - 12	99009-45500	D - 8		
90445-09220	D - 4	91317-06070	B - 13	93311-41530	C - 3		D - 10	99530-10114	B - 14		
90445-111J0	D - 4	91401-20012	D - 13	93315-11206	B - 14	95027-06016	D - 4	99590-10114	B - 12		
90450-22017	B - 7	91401-25015	D - 13	93315-32053	C - 11		D - 10	99590-17016	B - 13		
90450-25037	B - 7	91A20-05065	B - 7	93315-32056	C - 10		E - 3	9Y581-92111	D - 9		
90450-28014	B - 7	92017-06010	B - 12	93317-22262	C - 10	95027-06020	B - 8				
90450-54003	B - 8	92907-03100	B - 8	93332-00068	C - 14		C - 6				
90450-70072	B - 8	92907-05600	B - 3	93332-00081	C - 14		D - 2				
90460-15126	E - 3	92907-06100	D - 5	93340-21008	C - 2	95027-06025	B - 7				
90461-10136	B - 13	92907-06600	B - 14	93340-21505	B - 4		B - 12				
90464-13073	E - 3	92907-08200	D - 7	93342-22217	C - 10		B - 14				
90464-13077	E - 2	93102-12106	B - 6	93410-22039	C - 3		D - 11				
90464-50255	E - 3	93102-12224	B - 14	93430-08053	C - 2	95027-06030	B - 6				
90465-10098	E - 3	93102-17263	B - 15	93440-15012	B - 15		B - 14				
90465-13275	D - 4	93102-20485	B - 5		C - 3	95027-06040	B - 14				
	E - 3	93102-26042	C - 3	93450-16068	B - 5		B - 12				
90465-16258	D - 12	93102-26468	D - 6		E - 6	95027-06050	C - 10				
90467-09006	B - 7	93102-30008	B - 5	93507-16020	B - 4	95027-06065	B - 6				
90467-10008	D - 4	93104-08040	B - 2	93507-32009	B - 15	95027-08020	D - 7				
90467-13062	B - 2		B - 4	93603-14240	B - 4	95027-08035	C - 14				
90468-16191	D - 13	93106-22019	C - 10	93604-10011	B - 6	95027-08040	C - 7				
90468-26048	B - 15	93106-30044	D - 8		B - 14		C - 14				
90480-08608	D - 9	93106-30045	D - 8	93612-16254	B - 13	95027-08055	C - 7				
90480-15528	B - 7	93109-11073	B - 6	9383A-12017	C - 4	95607-10200	C - 13				
90480-16404	B - 12	93109-12012	C - 6	9383A-13031	C - 4	95701-06500	D - 12				