



PARTS CATALOGUE

YZ125T1 (1C31) CANADA,U.S.A.,SOUTH AFRICA

YZ125 (1C32) EUROPE

YZ125 (1C33) JAPAN

YZ125T1 (1C34) OCEANIA

YZ125T1/YZ125
PARTS CATALOGUE
©2004 by Yamaha Motor Co., Ltd.
1st edition, June 2004
All rights reserved.
Any reprinting or unauthorized use
without the written permission of
Yamaha Motor Co., Ltd.
is expressly prohibited.
Printed in Japan.

A3



A4

FOREWORD

This Parts Catalogue is related to the parts for the model(s) on the cover page. When you are ordering replacement parts, please refer to this Parts Catalogue and quote both part numbers and part names correctly.

1. Modifications or additions which have been made after the issue of the Parts Catalogue will be announced in the Parts News.

It is advisable that you make the necessary corrections to the Parts Catalogue according to the Parts News.

2. Abbreviations

The following abbreviations are used in this Parts Catalogue.

“UR” Use specified parts number.

“UN” Use as many as needed.

“AP” Alternate Parts

“LM” Locally Made (Parts need to be ordered locally)

“F#” Frame No. (Applicable machine No.)

“O/S” Over Size

3. The number of components for assembly

- Parts, which are to be supplied in an assembly, are listed with a dot (.) in front of the part name as shown below.
- The numeral appearing to the right of each component part indicates the quantity of parts for each assembly unit.

PART NO.	DESCRIPTION	Q'TY	REMARKS
2F5-83310-60	FRONT FLASHER LIGHT ASSY	2	
115-83311-60	.BULB (6V-18W)	1	

4. Applicable colours of graphics are represented in the “REMARKS” as shown below.

PART NO.	DESCRIPTION	Q'TY	REMARKS
2N4-24110-00-X5	FUEL TANK COMP.	2	MXR
3J1-24240-10	.GRAPHIC, FUEL TANK	1	FOR MXR

5. Note that the illustrations for reference in finding parts numbers are not to be used for assembling. When assembling, please use the applicable service manual.

6. The asterisk (*) before a reference number indicates modified items after the first edition.

FOREWORD

7. Applicable Serial No.

Engine Serial No.

Frame Serial No.

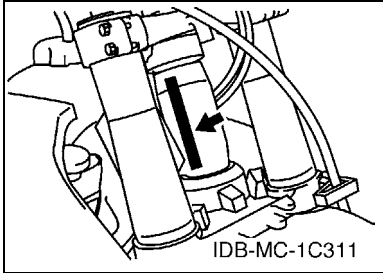
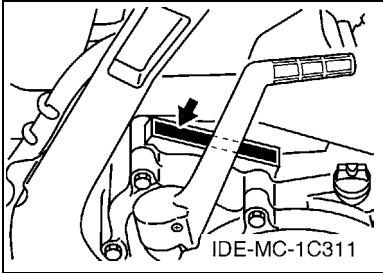

8. Applicable Colour Code (The (*) mark shows Model colour.)

Abbreviation	Colour Name	Colour Code
DPBSE(*)	DEEP PURPLISH BLUE SOLID E	0583

CONTENTS

ENGINE

CYLINDER HEAD	B2
GOVERNOR	B4
CRANKSHAFT & PISTON	B5
WATER PUMP	B6
RADIATOR & HOSE	B7
INTAKE	B8
CARBURETOR	B9
EXHAUST	B12
CRANKCASE	B13
CRANKCASE COVER 1	B14
STARTER	B15
CLUTCH	C2
TRANSMISSION	C3
SHIFT CAM & FORK	C5
SHIFT SHAFT	C6

CHASSIS

FRAME	C7
FENDER	C9
SIDE COVER	C10
REAR ARM	C11
REAR SUSPENSION	C13
STEERING	C15
FRONT FORK	D2
FUEL TANK	D5
SEAT	D7
FRONT WHEEL	D8
FRONT BRAKE CALIPER	D9
REAR WHEEL	D10
REAR BRAKE CALIPER	D12
STEERING HANDLE & CABLE	D13
FRONT MASTER CYLINDER	D14
STAND & FOOTREST	D15
REAR MASTER CYLINDER	E2
GENERATOR	E3
HANDLE SWITCH & LEVER	E4
ELECTRICAL 1	E5
ALTERNATE FOR CHASSIS	E6
OPTIONAL PARTS 1	E7

INDEX

NUMERICAL INDEX	M1
-----------------------	----

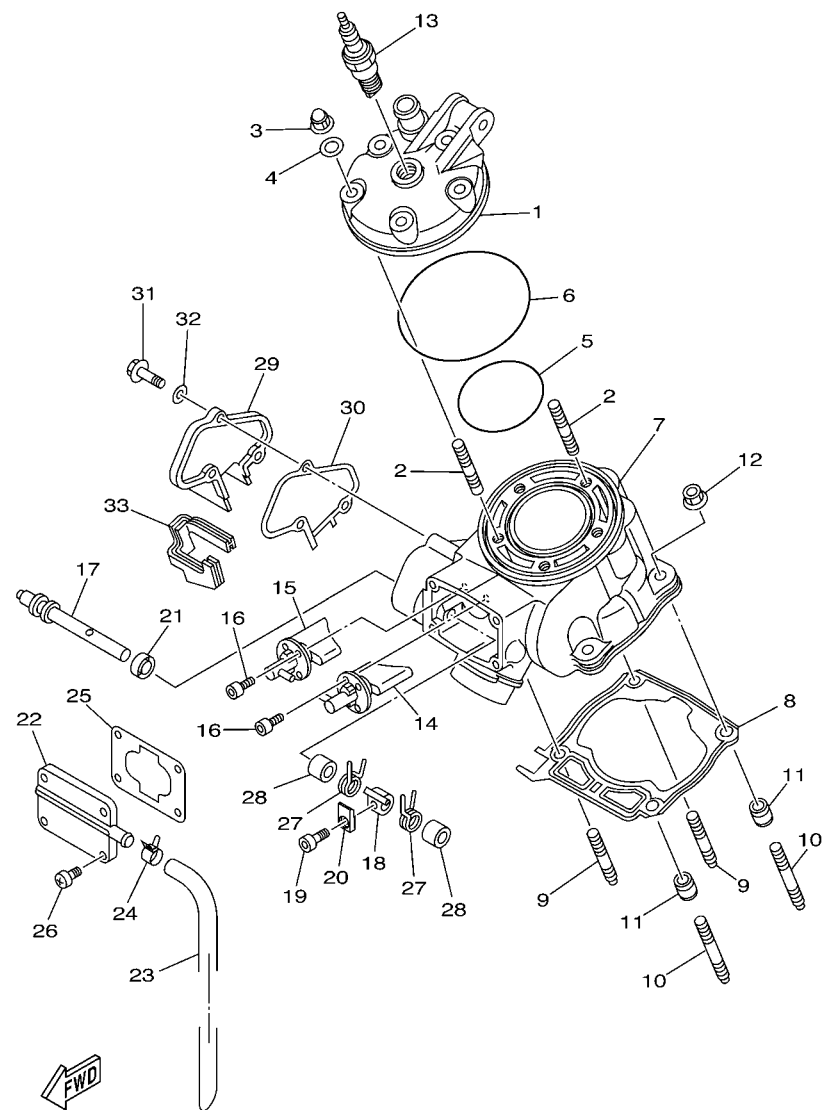

1C31100-D010

FIG. 1 CYLINDER HEAD

REF. NO.	PART NO.	DESCRIPTION	1C31	1C32	1C33	1C34	REMARKS
1	1C3-11111-00	HEAD, CYLINDER 1	1	1	1	1	
2	90116-08394	BOLT, STUD	5	5	5	5	
3	90176-08026	NUT, CROWN	5	5	5	5	
4	90201-080L8	WASHER, PLATE	5	5	5	5	
5	93210-63442	O-RING	1	1	1	1	
6	93210-90785	O-RING	1	1	1	1	
7	1C3-11311-00	CYLINDER 1	1	1	1	1	
8	1C3-11351-00	GASKET, CYLINDER	1	1	1	1	
9	90116-08318	BOLT, STUD	2	2	2	2	
10	90116-08388	BOLT, STUD	2	2	2	2	
11	99590-10114	PIN, DOWEL	2	2	2	2	
12	90179-08299	NUT	4	4	4	4	
13	94702-00324	PLUG, SPARK (NGK BR9EG)	1	1		1	
	94709-00324	PLUG, SPARK (NGK BR9EG)				1	
14	1C3-1131D-00	VALVE ASSY	1	1	1	1	
15	1C3-1132D-00	VALVE ASSY 2	1	1	1	1	
16	91317-05012	BOLT	4	4	4	4	
17	5HD-1131V-00	SHAFT 1	1	1	1	1	
18	4SS-11832-00	LEVER, LINK	1	1	1	1	
19	91317-04010	BOLT	1	1	1	1	
20	5UN-11395-00	HOLDER	1	1	1	1	
21	93104-08040	OIL SEAL	1	1	1	1	
22	4SS-1131M-01	COVER	1	1	1	1	
23	4JY-11166-00	PIPE, BREATHER 1	1	1	1	1	
24	90467-13062	CLIP	1	1	1	1	
25	1C3-11354-00	GASKET	1	1	1	1	
26	98907-05016	SCREW, BIND	4	4	4	4	

FIG. 2 GOVERNOR

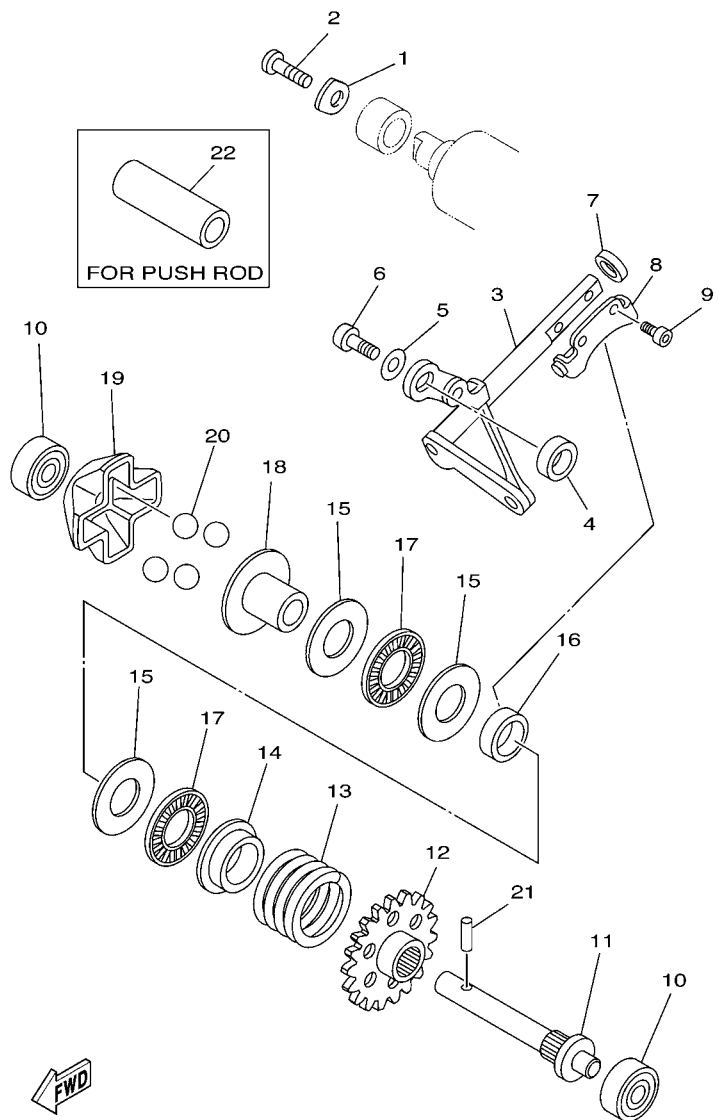

5NY1100-A020

REF. NO.	PART NO.	DESCRIPTION	1C31	1C32	1C33	1C34	REMARKS
1	4JY-11915-01	PLATE, THRUST 1	1	1	1	1	
2	98507-05012	SCREW, PAN HEAD	1	1	1	1	
3	1C3-11990-00	PUSH ROD ASSY	1	1	1	1	
4	90387-085E1	COLLAR	1	1	1	1	
5	90201-057H5	WASHER, PLATE	1	1	1	1	
6	97007-05012	BOLT	1	1	1	1	
7	93104-08040	OIL SEAL	1	1	1	1	
8	3JE-11922-01	FORK, GOVERNOR	1	1	1	1	
9	91317-04006	BOLT	2	2	2	2	
10	93300-60801	BEARING (B0060)	2	2	2	2	KOYO
11	5X4-11921-02	SHAFT, GOVERNOR	1	1	1	1	
12	5NY-11953-00	GEAR, GOVERNOR	1	1	1	1	
13	90501-30001	SPRING, COMPRESSION	1	1	1	1	
14	5CU-11952-00	PLATE	1	1	1	1	
15	90201-150U6	WASHER, PLATE	3	3	3	3	
16	90387-152F2	COLLAR	1	1	1	1	
17	93340-21505	BEARING	2	2	2	2	
18	5CU-11912-00	RETAINER, WEIGHT	1	1	1	1	
19	5CU-11911-00	RETAINER	1	1	1	1	
20	93507-16020	BALL	4	4	4	4	
21	93603-14240	PIN, DOWEL	1	1	1	1	
22	90387-107T9	COLLAR	1	1	1	1	AP

FIG. 3 CRANKSHAFT & PISTON

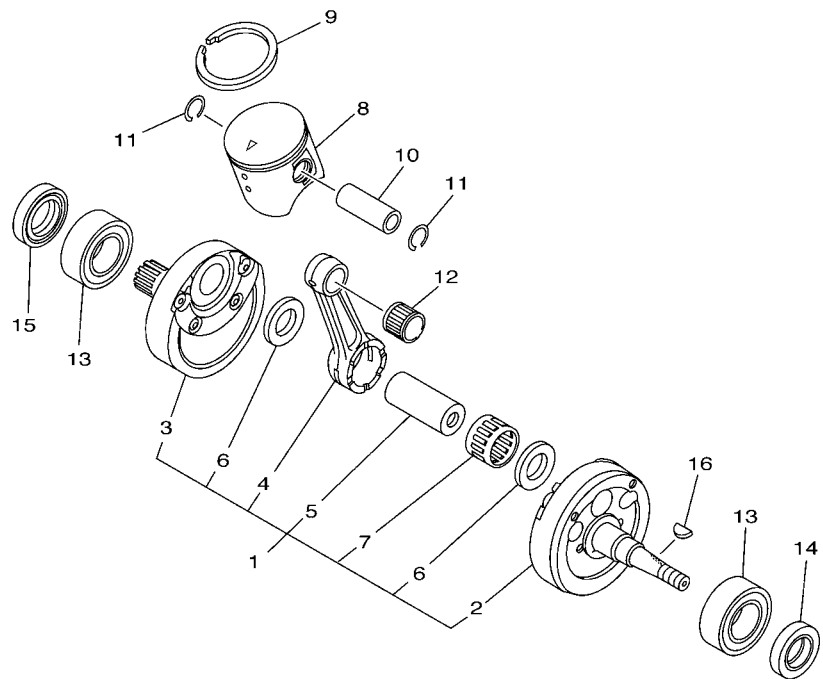

5NY1100-A030

REF. NO.	PART NO.	DESCRIPTION	1C31	1C32	1C33	1C34	REMARKS
1	1C3-11400-00	CRANKSHAFT ASSY	1	1	1	1	
2	1C3-11410-00	.CRANKSHAFT	1	1	1	1	
3	1C3-11420-00	.CRANKSHAFT	1	1	1	1	
4	1C3-11651-00	.ROD, CONNECTING	1	1	1	1	
5	3JD-11681-10	.PIN, CRANK 1	1	1	1	1	
6	90209-22326	.WASHER	2	2	2	2	
7	93310-52238	.BEARING	1	1	1	1	
8	1C3-11631-00-A0	PISTON (STD)	1	1	1	1	UR RED
	1C3-11631-00-B0	PISTON (STD)	1	1	1	1	UR ORANGE
	1C3-11631-00-C0	PISTON (STD)	1	1	1	1	UR GREEN
	1C3-11631-00-D0	PISTON (STD)	1	1	1	1	UR PURPLE
9	5NY-11611-00	RING, PISTON	1	1	1	1	
10	1C3-11633-00	PIN, PISTON	1	1	1	1	
11	93450-16068	CIRCLIP	2	2	2	2	
12	93310-21510	BEARING	1	1	1	1	
13	93306-37204	BEARING (63/22SH2-9TC4)	2	2	2	2	KOYO
14	93102-20485	OIL SEAL	1	1	1	1	
15	93102-22419	OIL SEAL	1	1	1	1	
16	90280-03017	KEY, WOODRUFF	1	1	1	1	

FIG. 4 WATER PUMP

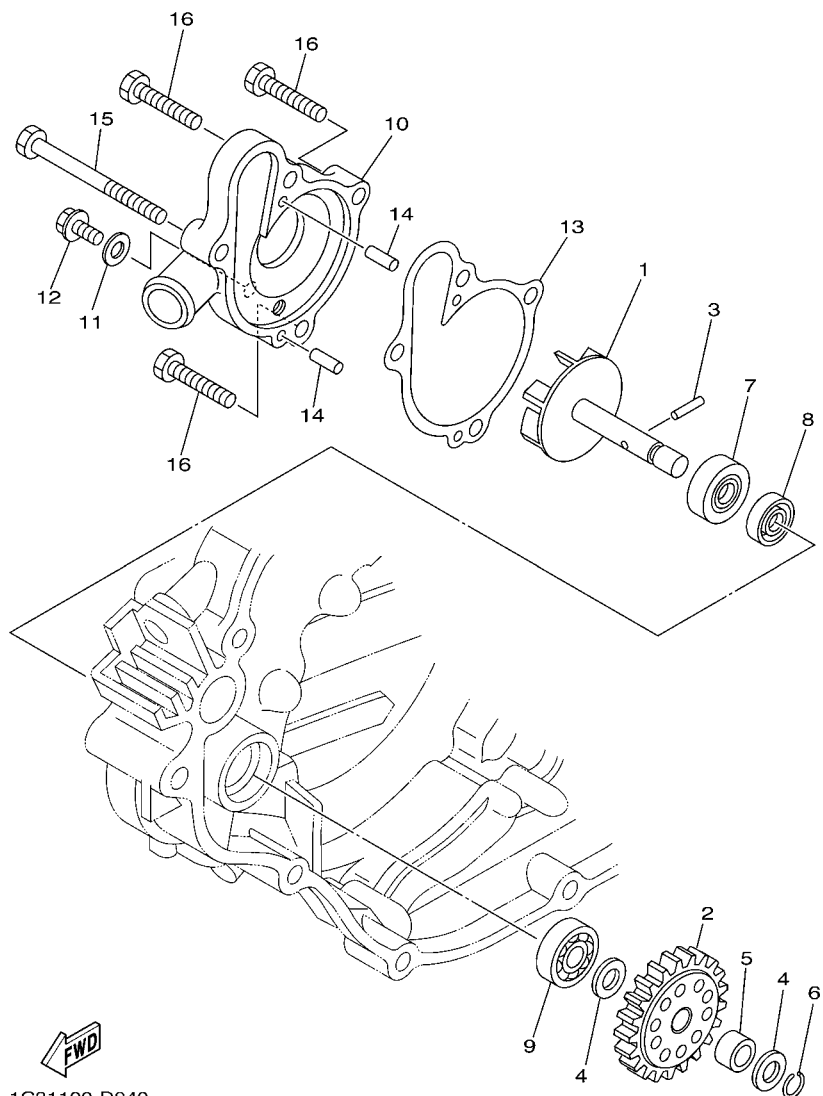

1C31100-D040

REF. NO.	PART NO.	DESCRIPTION	1C31	1C32	1C33	1C34	REMARKS
1	1C3-12450-00	IMPELLER SHAFT ASSY	1	1	1	1	
2	1C3-12453-01	GEAR	1	1	1	1	
3	93603-12007	PIN, DOWEL	1	1	1	1	
4	90201-08512	WASHER, PLATE	2	2	2	2	
5	90387-08032	COLLAR	1	1	1	1	
6	93440-07182	CIRCLIP	1	1	1	1	
7	93102-08004	OIL SEAL	1	1	1	1	
8	93102-08307	OIL SEAL	1	1	1	1	
9	93300-60801	BEARING (B0060)	1	1	1	1	UR KOYO
	93300-60814	BEARING (608M4ML01)	1	1	1	1	UR NMB
10	1C3-12422-00	COVER, HOUSING	1	1	1	1	
11	90430-06014	GASKET	1	1	1	1	
12	95027-06010	BOLT, FLANGE	1	1	1	1	
13	1C3-12428-00	GASKET, HOUSING COVER 2	1	1	1	1	
14	93604-10011	PIN, DOWEL	2	2	2	2	
15	95027-06065	BOLT, FLANGE	1	1	1	1	
16	95027-06025	BOLT, FLANGE	3	3	3	3	

FIG. 5 RADIATOR & HOSE

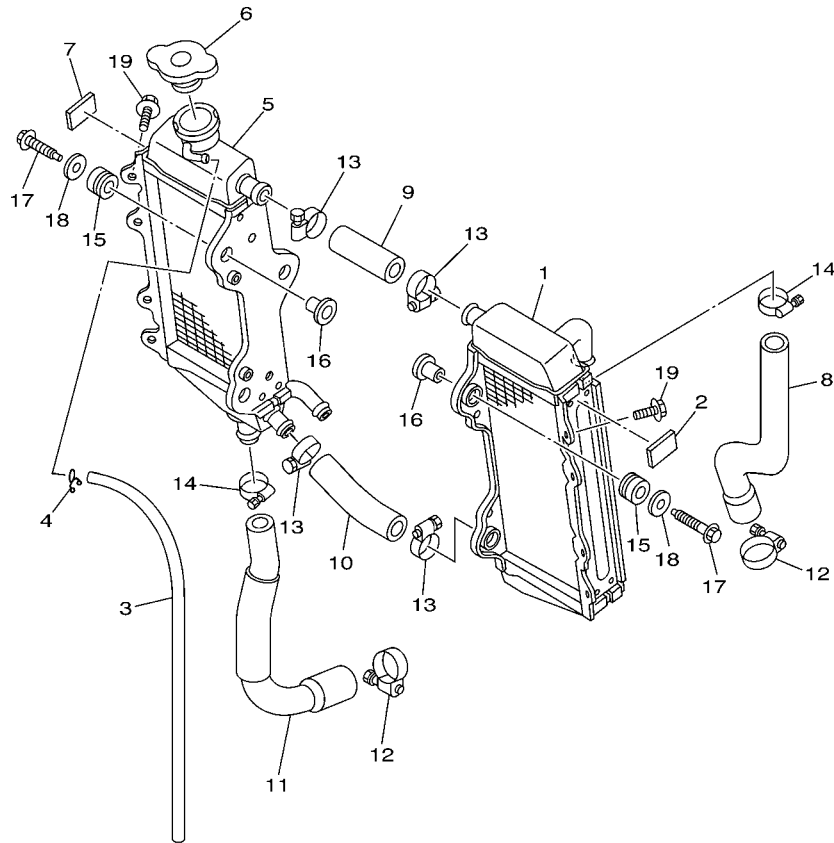

FWD
1C31100-D050

REF. NO.	PART NO.	DESCRIPTION	1C31	1C32	1C33	1C34	REMARKS
1	1C3-1240A-00	RADIATOR ASSY	1	1	1	1	
2	1C3-12465-00	DAMPER, RADIATOR	1	1	1	1	
3	91A20-05065	TUBE, FLEXIBLE VINYL	1	1	1	1	
4	90467-09006	CLIP	1	1	1	1	
5	1C3-12461-00	RADIATOR ASSY	1	1	1	1	
6	5HD-12462-00	CAP, RADIATOR	1	1	1	1	
7	1C3-12465-00	DAMPER, RADIATOR	1	1	1	1	
8	1C3-12481-00	PIPE 1	1	1	1	1	
9	1C3-12482-00	PIPE 2	1	1	1	1	
10	1C3-12483-00	PIPE 3	1	1	1	1	
11	1C3-12484-00	PIPE 4	1	1	1	1	
12	90450-28014	HOSE CLAMP ASSY	2	2	2	2	
13	90450-22017	HOSE CLAMP ASSY	4	4	4	4	
14	90450-25037	HOSE CLAMP ASSY	2	2	2	2	
15	90480-15528	GROMMET	6	6	6	6	
16	90387-06065	COLLAR	6	6	6	6	
17	95027-06025	BOLT, FLANGE	6	6	6	6	
18	90201-06571	WASHER, PLATE	6	6	6	6	
19	95827-06010	BOLT, FLANGE	2	2	2	2	

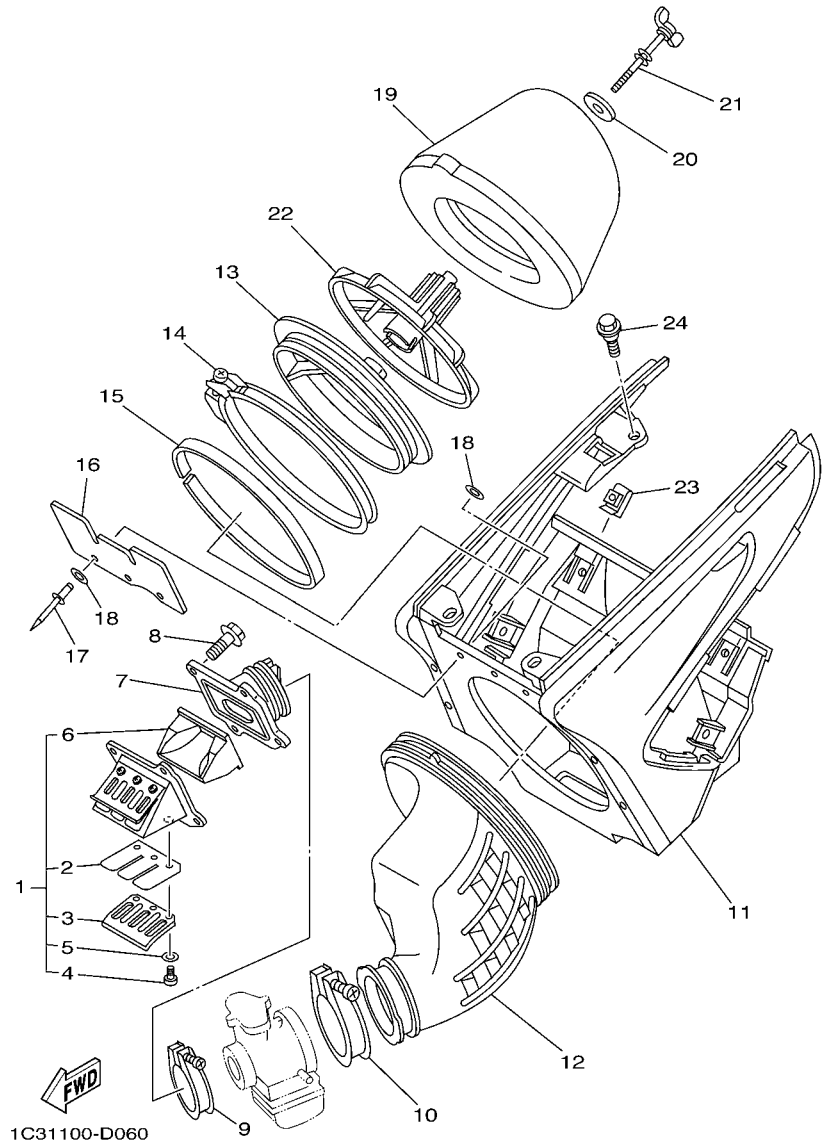
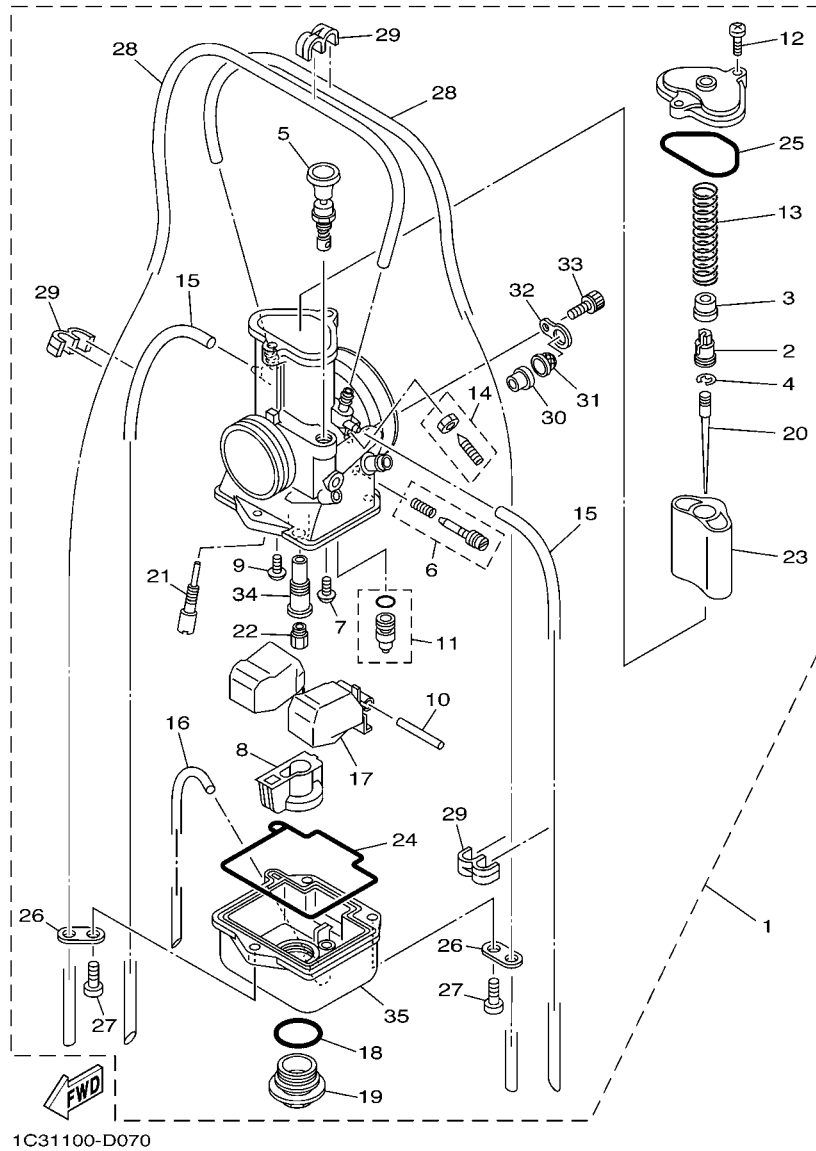

FIG. 6 INTAKE

REF. NO.	PART NO.	DESCRIPTION	1C31	1C32	1C33	1C34	REMARKS
1	1C3-13610-00	REED VALVE ASSY	1	1	1	1	
2	5UN-13613-00	.REED, VALVE	2	2	2	2	
3	5MV-13616-00	.STOPPER, REED VALVE	2	2	2	2	
4	98507-03006	.SCREW, PAN HEAD	6	6	6	6	
5	92907-03100	.WASHER, SPRING	6	6	6	6	
6	1C3-13625-00	SPACER, REED VALVE	1	1	1	1	
7	1C3-13565-00	JOINT, CARBURETOR	1	1	1	1	
8	95027-06020	BOLT, FLANGE	4	4	4	4	
9	90450-54004	HOSE CLAMP ASSY	1	1	1	1	
10	90450-70001	HOSE CLAMP ASSY	1	1	1	1	
11	5NY-14401-01	AIR CLEANER CASE ASSY	1	1	1	1	
12	1C3-14453-00	JOINT, AIR CLEANER 1	1	1	1	1	
13	5NY-14459-00	HOLDER, GUIDE	1	1	1	1	
14	5NY-14455-10	BAND	1	1	1	1	
15	5NY-14442-00	SPACER	1	1	1	1	
16	5NY-14417-00	COVER 1	1	1	1	1	
17	90267-32070	RIVET, BLIND	3	3	3	3	
18	90201-03313	WASHER, PLATE	6	6	6	6	
19	4XM-14451-00	ELEMENT, AIR CLEANER	1	1	1	1	
20	90209-06096	WASHER	1	1	1	1	
21	90122-06035	BOLT, WING	1	1	1	1	
22	3JD-14458-01	GUIDE	1	1	1	1	
23	90183-06023	NUT, SPRING	4	4	4	4	
24	90109-067F4	BOLT	4	4	4	4	



1C31100-D070

FIG. 7 CARBURETOR

REF. NO.	PART NO.	DESCRIPTION	1C31	1C32	1C33	1C34	REMARKS
1	1C3-14101-00	CARBURETOR ASSY 1	1			1	
	1C3-14101-10	CARBURETOR ASSY 1		1			
	1C3-14101-20	CARBURETOR ASSY 1			1		
2	5HD-14261-00	.HOLDER	1	1	1	1	
3	4PE-14194-00	.RING	1	1	1	1	
4	3MA-14159-00	.CLIP	1	1	1	1	
5	3JE-14171-00	.PLUNGER, STARTER	1	1	1	1	
6	5UN-14104-00	.AIR SCREW SET	1	1	1	1	
7	1FN-14565-00	.SCREW	1	1	1	1	
8	5ET-14261-01	.HOLDER	1	1	1	1	
9	98507-04008	.SCREW, PAN HEAD	1	1	1	1	
10	353-14186-00	.PIN, FLOAT	1	1	1	1	
11	4PE-14107-38	.NEEDLE VALVE SET	1	1	1	1	
12	98507-04014	.SCREW, PAN HEAD	2	2	2	2	
13	4PE-14131-00	.SPRING, THROTTLE VALVE	1	1	1	1	
14	4PE-14103-00	.THROTTLE SCREW SET	1	1	1	1	
15	5ET-14197-00	.PIPE	2	2	2	2	
16	10V-14196-00	.PIPE	1	1	1	1	
17	5ET-14185-00	.FLOAT	1	1	1	1	
18	2K6-14147-00	.O-RING	1	1	1	1	
19	5ET-14115-00	.PLUG, SCREW	1	1	1	1	
20	284-14116-E5	.NEEDLE (6CHY5-80)	1	1		1	STD
	284-14116-F5	.NEEDLE (6CHY6-80)			1		STD
	284-14116-E3	.NEEDLE (6CHY5-78)	1	1	1	1	AP
	284-14116-E4	.NEEDLE (6CHY5-79)	1	1	1	1	AP
	284-14116-E5	.NEEDLE (6CHY5-80)			1		AP
	284-14116-E6	.NEEDLE (6CHY5-81)	1	1	1	1	AP

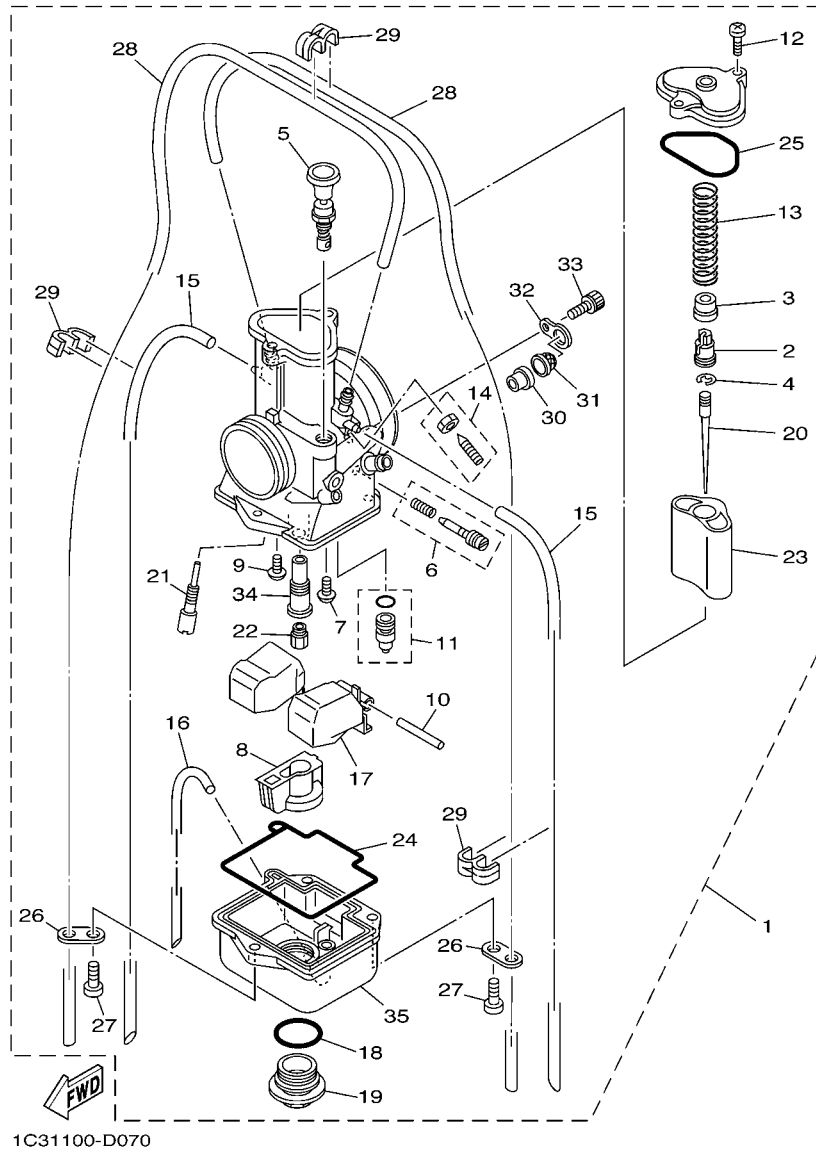

FIG. 7 CARBURETOR

REF. NO.	PART NO.	DESCRIPTION	1C31	1C32	1C33	1C34	REMARKS
20	284-14116-E7	.NEEDLE (6CHY5-82)	1	1	1	1	AP
	284-14116-F3	.NEEDLE (6CHY6-78)	1	1	1	1	AP
	284-14116-F4	.NEEDLE (6CHY6-79)	1	1	1	1	AP
	284-14116-F5	.NEEDLE (6CHY6-80)	1	1		1	AP
	284-14116-F6	.NEEDLE (6CHY6-81)	1	1	1	1	AP
	284-14116-F7	.NEEDLE (6CHY6-82)	1	1	1	1	AP
	284-14116-G3	.NEEDLE (6CHY18-78)	1	1	1	1	AP
	284-14116-G4	.NEEDLE (6CHY18-79)	1	1	1	1	AP
	284-14116-G5	.NEEDLE (6CHY18-80)	1	1	1	1	AP
	284-14116-G6	.NEEDLE (6CHY18-81)	1	1	1	1	AP
	284-14116-G7	.NEEDLE (6CHY18-82)	1	1	1	1	AP
21	4KM-14142-40	.JET, PILOT (# 40)	1	1	1	1	STD
	4KM-14142-30	.JET, PILOT (# 30)	1	1	1	1	AP
	4KM-14142-32	.JET, PILOT (# 32.5)	1	1	1	1	AP
	4KM-14142-35	.JET, PILOT (# 35)	1	1	1	1	AP
	4KM-14142-37	.JET, PILOT (# 37.5)	1	1	1	1	AP
	4KM-14142-42	.JET, PILOT (# 42.5)	1	1	1	1	AP
	4KM-14142-45	.JET, PILOT (# 45)	1	1	1	1	AP
	4KM-14142-47	.JET, PILOT (# 47.5)	1	1	1	1	AP
	4KM-14142-50	.JET, PILOT (# 50)	1	1	1	1	AP
22	137-14143-82	.JET, MAIN (#410)	1		1	1	STD
	137-14143-86	.JET, MAIN (#430)		1			STD
	137-14143-78	.JET, MAIN (#390)	1	1	1	1	AP
	137-14143-80	.JET, MAIN (#400)	1	1	1	1	AP
	137-14143-82	.JET, MAIN (#410)		1			AP
	137-14143-84	.JET, MAIN (#420)	1	1	1	1	AP
	137-14143-86	.JET, MAIN (#430)	1		1	1	AP

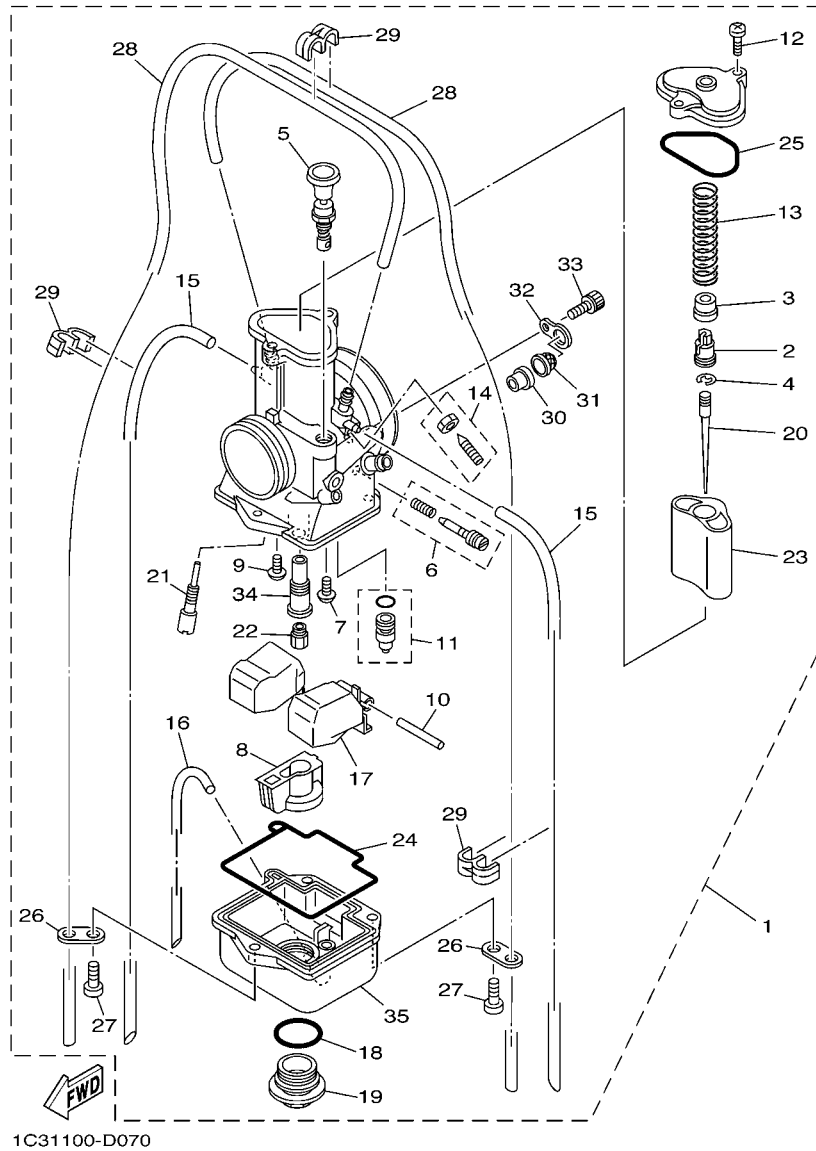
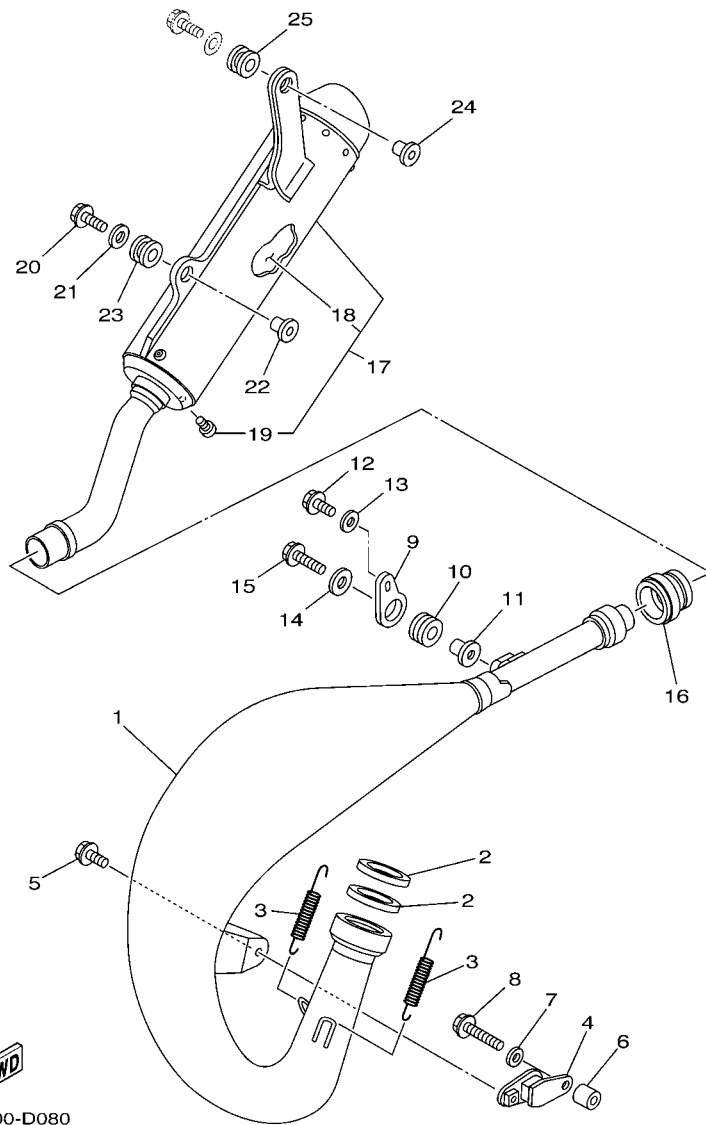

FIG. 7 CARBURETOR

REF. NO.	PART NO.	DESCRIPTION	1C31	1C32	1C33	1C34	REMARKS
22	137-14143-88	.JET, MAIN (#440)	1	1	1	1	AP
	137-14143-90	.JET, MAIN (#450)	1	1	1	1	AP
23	1C3-14112-40	.VALVE, THROTTLE 1 (4.0)	1	1	1	1	STD
	1C3-14112-42	.VALVE, THROTTLE 1 (4.25)	1	1	1	1	AP
24	5ET-1416A-00	.O-RING	1	1	1	1	
25	5ET-14147-00	.O-RING	1	1	1	1	
26	51R-14146-00	.PLATE	2	2	2	2	
27	98502-05014	.SCREW, PAN HEAD	3	3	3	3	
28	2HH-14197-00	.PIPE	2	2	2	2	
29	87M-14137-00	.CLIP	3	3	3	3	
30	5MV-14194-00	.RING	1	1	1	1	
31	5MV-24514-00	.NET, FILTER 1	1	1	1	1	
32	5MV-14146-00	.PLATE	1	1	1	1	
33	5MV-14216-00	.SCREW	1	1	1	1	
34	5MV-14261-00	.HOLDER	1	1	1	1	
35	5NY-14181-00	.BODY, FLOAT CHAMBER 1	1	1	1	1	

FIG. 8 EXHAUST



REF. NO.	PART NO.	DESCRIPTION	1C31	1C32	1C33	1C34	REMARKS
1	1C3-14610-00	EXHAUST PIPE ASSY 1	1	1	1	1	
2	5MV-14642-00	SEAL, EXHAUST	2	2	2	2	
3	90506-20012	SPRING, TENSION	2	2	2	2	
4	565-14771-00	STAY, MUFFLER 1	1	1	1	1	
5	95027-06012	BOLT, FLANGE	1	1	1	1	
6	1C3-14763-00	SPACER	1	1	1	1	
7	90201-06060	WASHER, PLATE	1	1	1	1	
8	95027-06025	BOLT, FLANGE	1	1	1	1	
9	5CU-14771-01	STAY, MUFFLER 1	1	1	1	1	
10	90480-16561	GROMMET	1	1	1	1	
11	90387-063G3	COLLAR	1	1	1	1	
12	95027-06014	BOLT, FLANGE	1	1	1	1	
13	90201-06557	WASHER, PLATE	1	1	1	1	
14	90201-06071	WASHER, PLATE	1	1	1	1	
15	95027-06025	BOLT, FLANGE	1	1	1	1	
16	4JY-14615-00	JOINT, EXHAUST 1	1	1	1	1	
17	5XE-14753-01	SILENCER, EXHAUST	1	1	1	1	
18	5NY-1469A-00	.FIBER	1	1	1	1	
19	92017-06010	.BOLT, BUTTON HEAD	2	2	2	2	
20	95027-06025	BOLT, FLANGE	1	1	1	1	
21	90201-06071	WASHER, PLATE	1	1	1	1	
22	90387-063G3	COLLAR	1	1	1	1	
23	90480-16561	GROMMET	1	1	1	1	
24	90387-06039	COLLAR	1	1	1	1	
25	90480-16404	GROMMET	1	1	1	1	

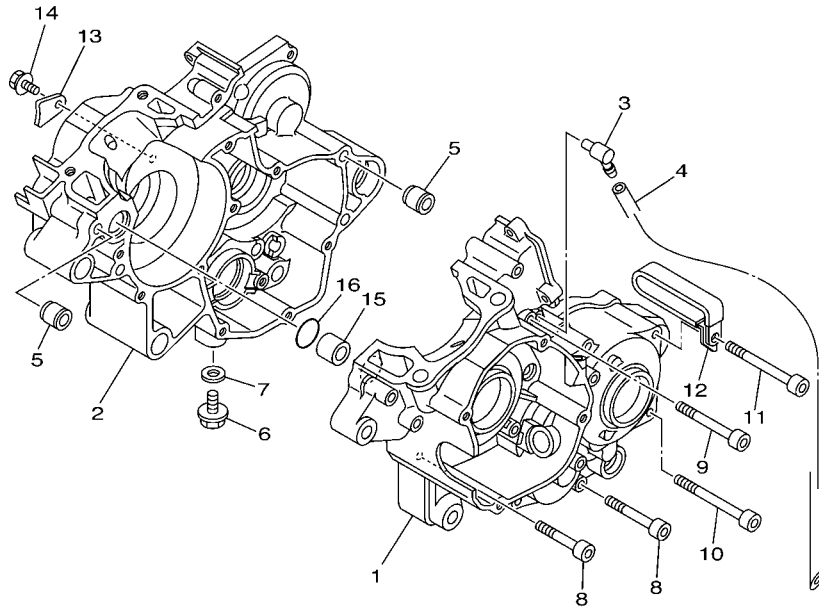
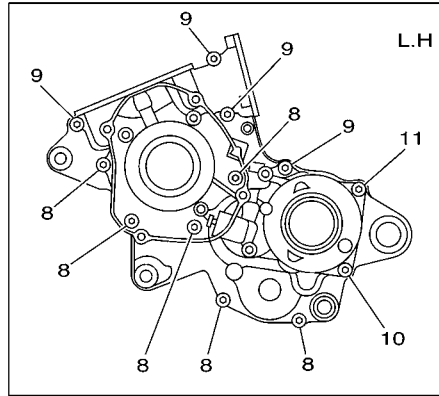

1C31100-D090

FIG. 9 CRANKCASE

REF. NO.	PART NO.	DESCRIPTION	1C31	1C32	1C33	1C34	REMARKS
1	1C3-15111-00	CRANKCASE 1	1	1	1	1	
2	1C3-15121-00	CRANKCASE 2	1	1	1	1	
3	353-13115-01	CONNECTOR, SUCTION PIPE	1	1	1	1	
4	90445-08605	HOSE	1	1	1	1	
5	99530-10116	PIN, DOWEL	2	2	2	2	
6	95027-10016	BOLT, FLANGE	1	1	1	1	
7	90430-10188	GASKET	1	1	1	1	
8	91317-06045	BOLT	6	6	6	6	
9	91317-06055	BOLT	4	4	4	4	
10	91317-06065	BOLT	1	1	1	1	
11	91317-06075	BOLT	1	1	1	1	
12	90461-10136	CLAMP	1	1	1	1	
13	4V4-15118-00	HOLDER	1	1	1	1	
14	90105-06556	BOLT, FLANGE	1	1	1	1	
15	99590-17016	PIN, DOWEL	1	1	1	1	
16	93210-16314	O-RING	1	1	1	1	

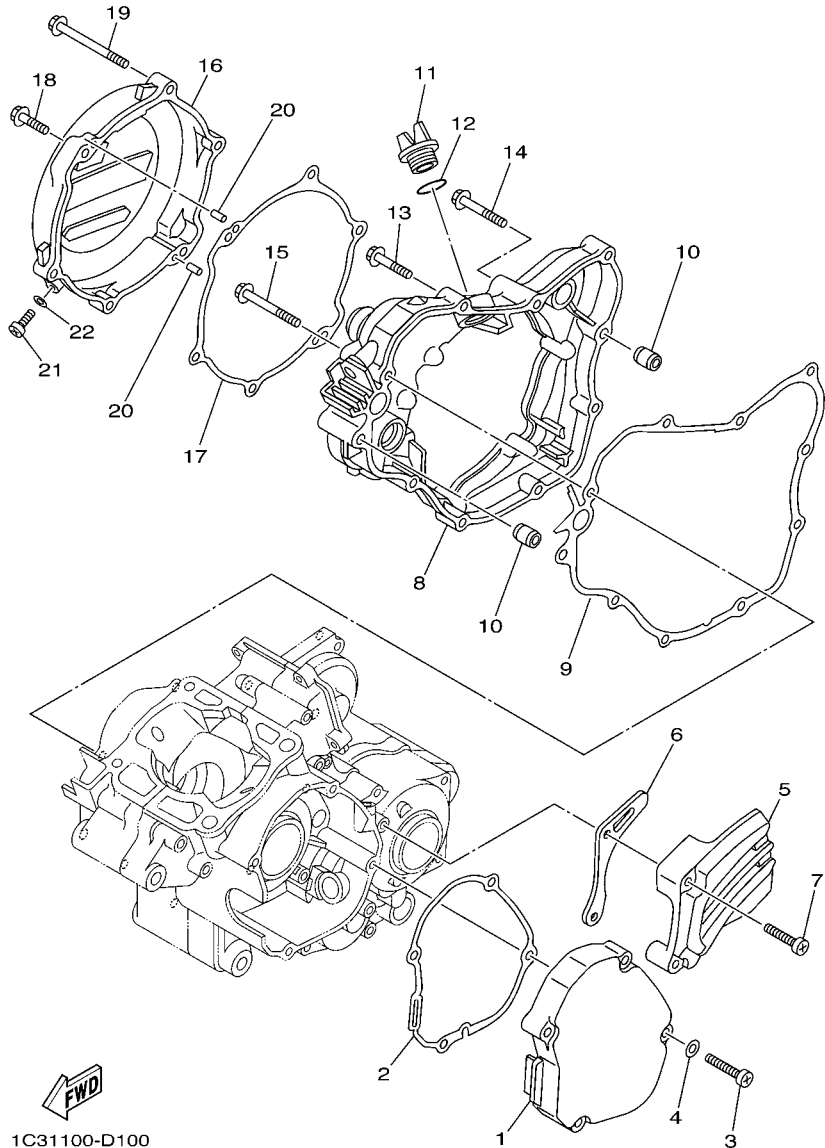

1C31100-D100

FIG. 10 CRANKCASE COVER 1

REF. NO.	PART NO.	DESCRIPTION	1C31	1C32	1C33	1C34	REMARKS
1	1C3-15411-00	COVER, CRANKCASE 1	1	1	1	1	
2	1C3-15451-00	GASKET, CRANKCASE COVER 1	1	1	1	1	
3	98507-06030	SCREW, PAN HEAD	4	4	4	4	
4	92907-06600	WASHER, PLATE	4	4	4	4	
5	1C3-15421-00	COVER, CRANKCASE 2	1	1	1	1	
6	1C3-17466-00	GUIDE, CHAIN	1	1	1	1	
7	98507-06030	SCREW, PAN HEAD	2	2	2	2	
8	1C3-15431-00	COVER, CRANKCASE 3	1	1	1	1	
9	1C3-15462-00	GASKET, CRANKCASE COVER 3	1	1	1	1	
10	99530-08016	PIN, DOWEL	2	2	2	2	
11	3Y1-15363-00	PLUG, OIL	1	1	1	1	
12	93210-19123	O-RING	1	1	1	1	
13	95027-06030	BOLT, FLANGE	6	6	6	6	
14	95027-06040	BOLT, FLANGE	1	1	1	1	
15	95027-06050	BOLT, FLANGE	1	1	1	1	
16	1C3-15415-00	COVER, GENERATOR	1	1	1	1	
17	1C3-15463-00	GASKET, CARBURETOR COVER 2	1	1	1	1	
18	95027-06065	BOLT, FLANGE	1	1	1	1	
19	95027-06025	BOLT, FLANGE	5	5	5	5	
20	93604-10011	PIN, DOWEL	2	2	2	2	
21	92017-06012	BOLT, BUTTON HEAD	1	1	1	1	
22	90430-06014	GASKET	1	1	1	1	

FIG. 11 STARTER

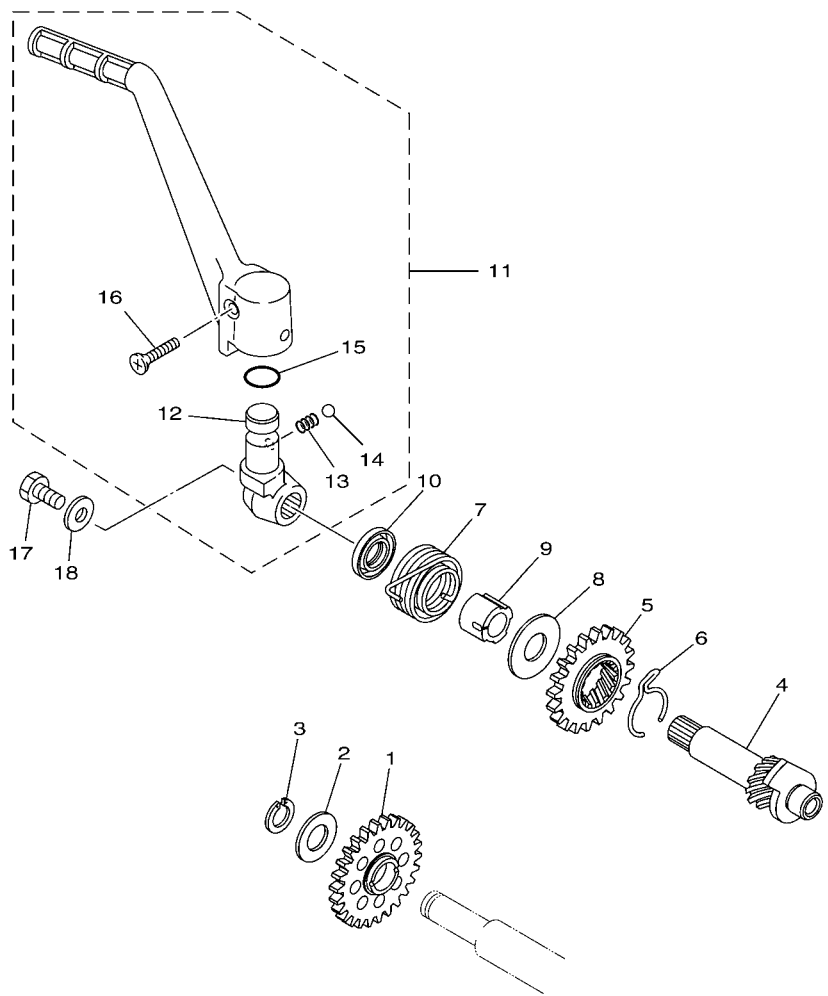

REF. NO.	PART NO.	DESCRIPTION	1C31	1C32	1C33	1C34	REMARKS
1	1C3-15651-00	GEAR, KICK IDLE	1	1	1	1	
2	90201-175F6	WASHER, PLATE	1	1	1	1	
3	99009-17400	CIRCLIP	1	1	1	1	
4	1C3-15660-00	KICK AXLE ASSY	1	1	1	1	
5	1C3-15641-00	GEAR, KICK	1	1	1	1	
6	90468-26048	CLIP	1	1	1	1	
7	90508-26450	SPRING, TORSION	1	1	1	1	
8	90201-171G4	WASHER, PLATE	1	1	1	1	
9	1C3-15666-00	SPACER	1	1	1	1	
10	93102-17263	OIL SEAL	1	1	1	1	
11	4DB-15620-04	KICK CRANK ASSY	1	1	1	1	
12	4DB-15621-03	.BOSS, KICK CRANK	1	1	1	1	
13	90501-12081	.SPRING, COMPRESSION	1	1	1	1	
14	93507-32009	.BALL	1	1	1	1	
15	93210-15171	.O-RING	1	1	1	1	
16	90152-06010	.SCREW, COUNTERSUNK	1	1	1	1	
17	97027-06012	BOLT	1	1	1	1	
18	90201-06060	WASHER, PLATE	1	1	1	1	

1C31100-D110

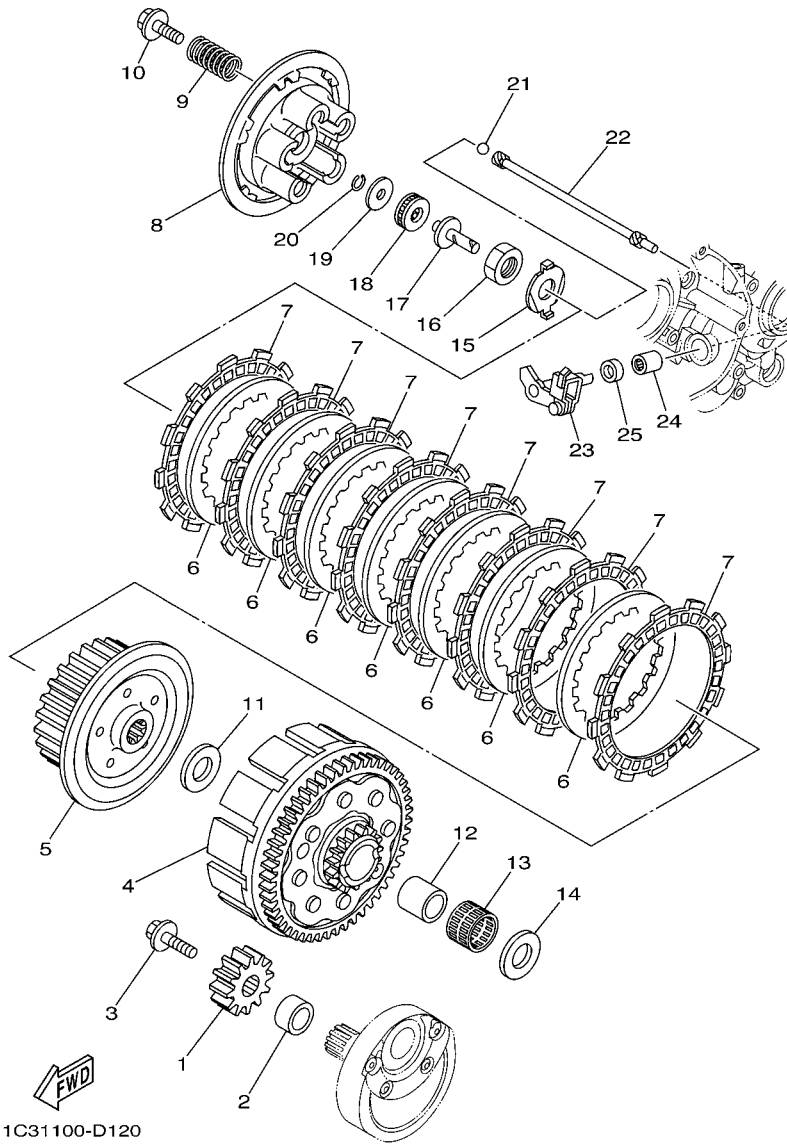
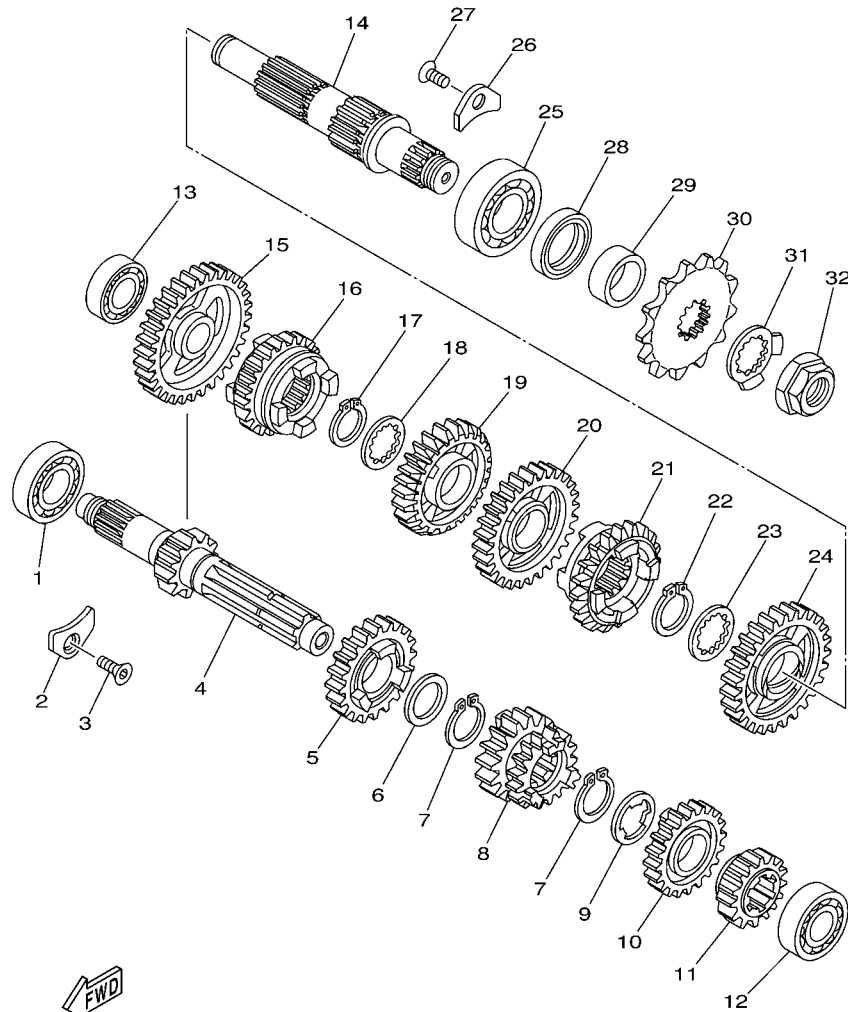

FIG. 12 CLUTCH

REF. NO.	PART NO.	DESCRIPTION	1C31	1C32	1C33	1C34	REMARKS
1	1C3-16111-00	GEAR, PRIMARY DRIVE	1	1	1	1	
2	90387-172K2	COLLAR	1	1	1	1	
3	90105-08071	BOLT, FLANGE	1	1	1	1	
4	1C3-16150-00	PRIMARY DRIVEN GEAR COMP.	1	1	1	1	
5	5NY-16371-00	BOSS, CLUTCH	1	1	1	1	
6	3XJ-16324-01	PLATE, CLUTCH 1	7	7	7	7	
7	3XJ-16321-00	PLATE, FRICTION	8	8	8	8	
8	5HD-16351-00	PLATE, PRESSURE 1	1	1	1	1	
9	90501-23598	SPRING, COMPRESSION	5	5	5	5	
10	90159-06016	SCREW, WITH WASHER	5	5	5	5	
11	90201-20611	WASHER, PLATE	1	1	1	1	
12	1C3-16181-00	SPACER 1	1	1	1	1	
13	93310-22539	BEARING	1	1	1	1	
14	90201-20611	WASHER, PLATE	1	1	1	1	
15	90215-16289	WASHER, LOCK	1	1	1	1	
16	90170-16326	NUT	1	1	1	1	
17	5NL-16356-00	ROD, PUSH 1	1	1	1	1	
18	93340-21008	BEARING	1	1	1	1	
19	90201-080H1	WASHER, PLATE	1	1	1	1	
20	93440-07182	CIRCLIP	1	1	1	1	
21	93511-32027	BALL	1	1	1	1	
22	1C3-16357-00	ROD, PUSH 2	1	1	1	1	
23	1C3-16380-00	PUSH LEVER ASSY	1	1	1	1	
24	93315-11040	BEARING	1	1	1	1	
25	93102-10008	OIL SEAL	1	1	1	1	

FIG. 13 TRANSMISSION



1C31100-D130

REF. NO.	PART NO.	DESCRIPTION	1C31	1C32	1C33	1C34	REMARKS
1	93306-00442	BEARING	1	1	1	1	
2	4JT-15381-01	PLATE, BEARING COVER	1	1	1	1	
3	90149-06326	SCREW	1	1	1	1	
4	1C3-17411-10	AXLE, MAIN (13T)	1	1	1	1	
5	1C3-17161-10	GEAR, 6TH PINION (21T)	1	1	1	1	
6	90201-22555	WASHER, PLATE	1	1	1	1	
7	93410-22039	CIRCLIP	2	2	2	2	
8	1C3-17131-10	GEAR, 3RD PINION (17T/17T)	1	1	1	1	
9	90209-18135	WASHER	1	1	1	1	
10	1C3-17151-10	GEAR, 5TH PINION (20T)	1	1	1	1	
11	1C3-17121-10	GEAR, 2ND PINION (15T)	1	1	1	1	
12	93306-20351	BEARING	1	1	1	1	
13	93306-00326	BEARING	1	1	1	1	
14	1C3-17421-00	AXLE, DRIVE	1	1	1	1	
15	1C3-17211-10	GEAR, 1ST WHEEL (31T)	1	1	1	1	
16	1C3-17261-10	GEAR, 6TH WHEEL (23T)	1	1	1	1	
17	93410-22039	CIRCLIP	1	1	1	1	
18	90209-20008	WASHER	1	1	1	1	
19	1C3-17241-10	GEAR, 4TH WHEEL (23T)	1	1	1	1	
20	1C3-17231-10	GEAR, 3RD WHEEL (27T)	1	1	1	1	
21	1C3-17251-10	GEAR, 5TH WHEEL (24T)	1	1	1	1	
22	93410-26067	CIRCLIP	1	1	1	1	
23	90209-23012	WASHER	1	1	1	1	
24	1C3-17221-10	GEAR, 2ND WHEEL (29T)	1	1	1	1	
25	93306-20447	BEARING	1	1	1	1	
26	4JT-15381-01	PLATE, BEARING COVER	2	2	2	2	
27	90149-06326	SCREW	2	2	2	2	

FIG. 13 TRANSMISSION

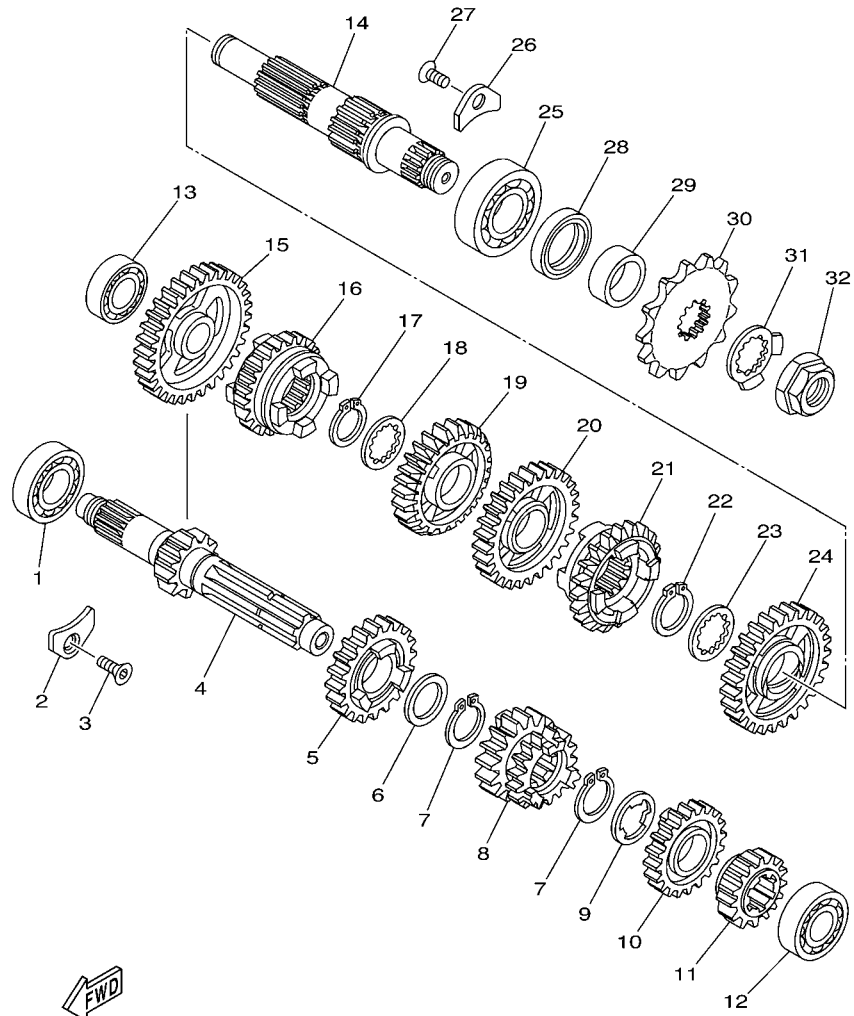

1C31100-D130

REF. NO.	PART NO.	DESCRIPTION	1C31	1C32	1C33	1C34	REMARKS
28	93102-28012	OIL SEAL	1	1	1	1	
29	90387-22004	COLLAR	1	1	1	1	
30	9383B-13218	SPROCKET, DRIVE (13T)	1	1	1	1	
31	90215-20003	WASHER, LOCK	1	1	1	1	
32	90179-18001	NUT	1	1	1	1	

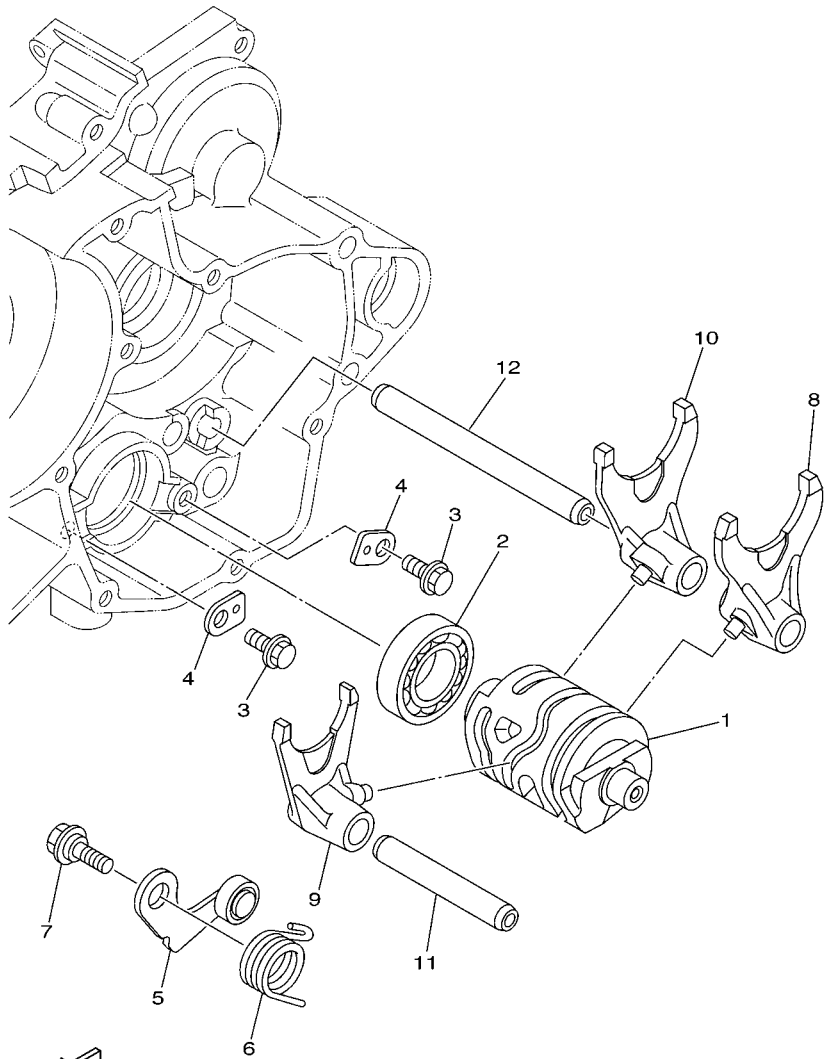

 1C31100-D140

FIG. 14 SHIFT CAM & FORK

REF. NO.	PART NO.	DESCRIPTION	1C31	1C32	1C33	1C34	REMARKS
1	1C3-18541-00	CAM, SHIFT	1	1	1	1	
2	93306-90408	BEARING	1	1	1	1	
3	90105-06553	BOLT, FLANGE	2	2	2	2	
4	1C3-18562-00	PLATE, STOPPER 2	2	2	2	2	
5	1C3-18140-00	STOPPER LEVER ASSY	1	1	1	1	
6	90508-261B7	SPRING, TORSION	1	1	1	1	
7	90109-063F8	BOLT	1	1	1	1	
8	1C3-18511-00	FORK, SHIFT 1	1	1	1	1	
9	1C3-18512-00	FORK, SHIFT 2	1	1	1	1	
10	1C3-18513-00	FORK, SHIFT 3	1	1	1	1	
11	3XV-18531-00	BAR, SHIFT FORK GUIDE 1	1	1	1	1	
12	4JG-18531-00	BAR, SHIFT FORK GUIDE 1	1	1	1	1	

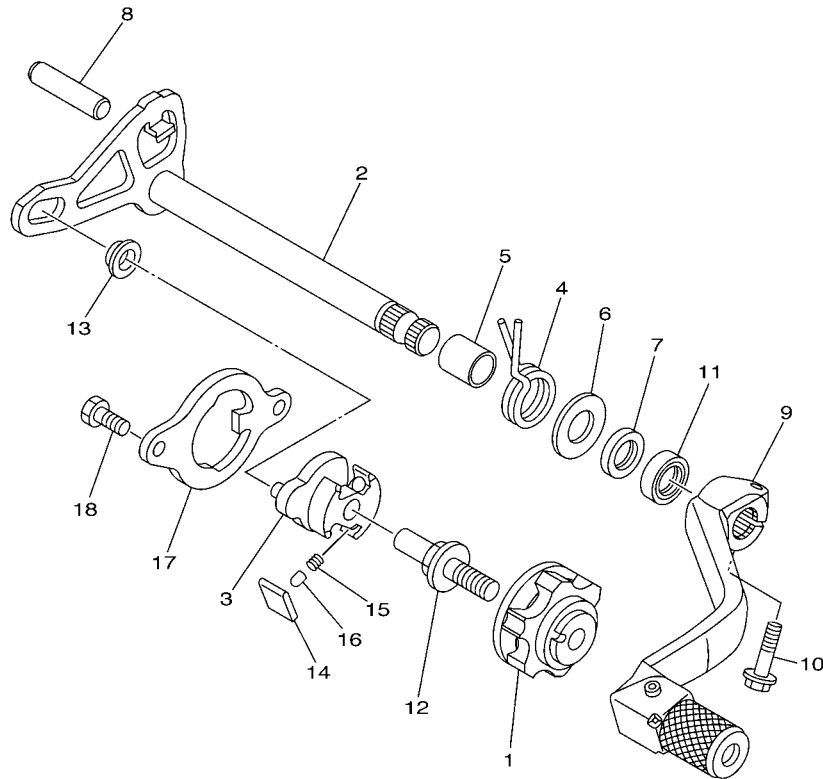
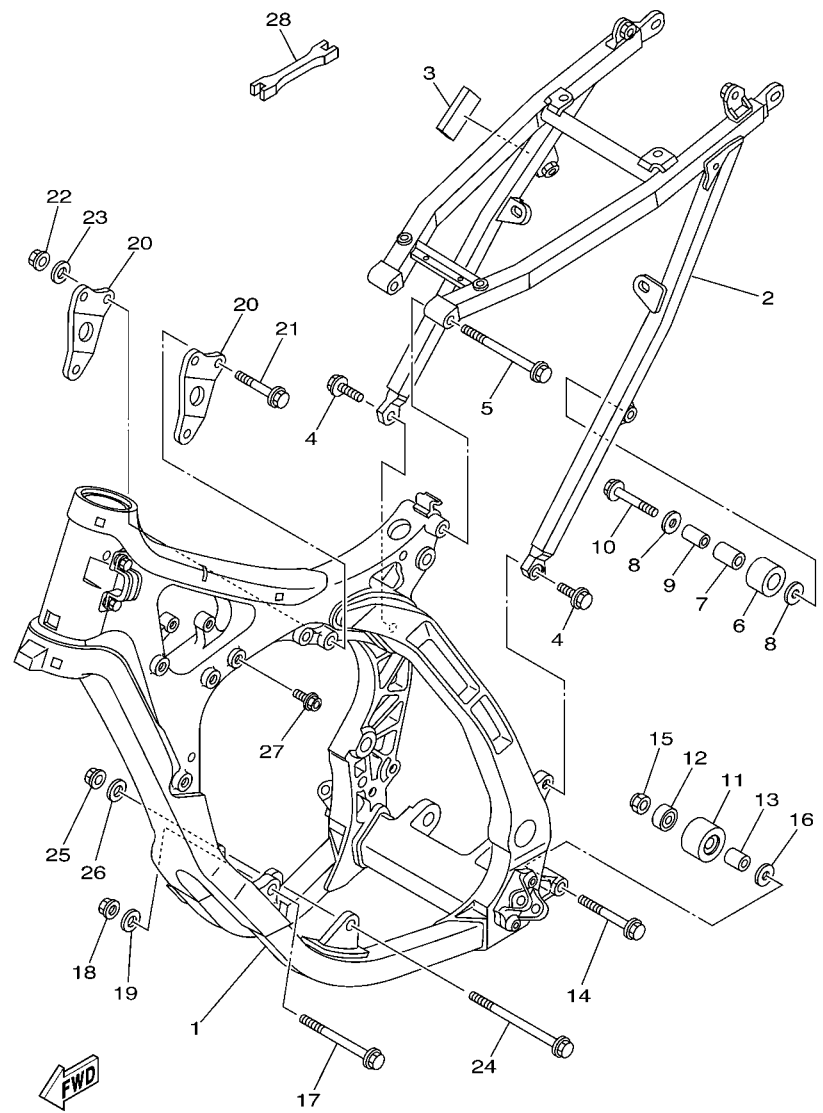

FIG. 15 SHIFT SHAFT

REF. NO.	PART NO.	DESCRIPTION	1C31	1C32	1C33	1C34	REMARKS
1	1C3-18185-00	SEGMENT	1	1	1	1	
2	1C3-18101-00	SHIFT SHAFT ASSY	1	1	1	1	
3	5LP-18122-01	LEVER, SHIFT 2	1	1	1	1	
4	90508-29020	SPRING, TORSION	1	1	1	1	
5	90560-12280	SPACER	1	1	1	1	
6	90201-12020	WASHER, PLATE	1	1	1	1	
7	93104-12003	OIL SEAL	1	1	1	1	
8	93608-33002	PIN, DOWEL	1	1	1	1	
9	1C3-18110-00	SHIFT PEDAL ASSY	1	1	1	1	
10	95027-06020	BOLT, FLANGE	1	1	1	1	
11	93102-12224	OIL SEAL	1	1	1	1	
12	3XJ-18173-10	PIN, SHIFT	1	1	1	1	
13	3XJ-18178-00	ROLLER, SHIFT LEVER	1	1	1	1	
14	3XJ-18182-00	PAWL, SHIFTER	2	2	2	2	
15	90501-052G5	SPRING, COMPRESSION	2	2	2	2	
16	3XJ-18184-00	PIN, PAWL	2	2	2	2	
17	1C3-18172-00	GUIDE, SHIFT	1	1	1	1	
18	90101-06034	BOLT	2	2	2	2	



1C31100-D150



1C31100-D160

FIG. 16 FRAME

REF. NO.	PART NO.	DESCRIPTION	1C31	1C32	1C33	1C34	REMARKS
1	1C3-21101-00	FRONT FRAME COMP.	1	1	1	1	
2	1C3-21190-00	REAR FRAME COMP.	1	1	1	1	
3	5GJ-21717-00	DAMPER	1	1	1	1	
4	90105-08057	BOLT, FLANGE	2	2	2	2	
5	90105-08120	BOLT, FLANGE	1	1	1	1	
6	30X-22178-00	TENSIONER	1	1	1	1	
7	4V4-22184-00	BUSH	1	1	1	1	
8	90201-08039	WASHER, PLATE	2	2	2	2	
9	90387-08027	COLLAR	1	1	1	1	
10	95027-08040	BOLT, FLANGE	1	1	1	1	
11	3JD-22178-20	TENSIONER	1	1	1	1	
12	93300-60804	BEARING	1	1	1	1	
13	90387-086N4	COLLAR	1	1	1	1	
14	95027-08055	BOLT, FLANGE	1	1	1	1	
15	90185-08055	NUT, SELF-LOCKING	1	1	1	1	
16	90201-086P8	WASHER, PLATE	1	1	1	1	
17	90105-10080	BOLT, FLANGE	1	1	1	1	
18	90179-10658	NUT	1	1	1	1	
19	92907-10200	WASHER, PLAIN	1	1	1	1	
20	1C3-21425-00	BRACKET, REAR UPPER 1	2	2	2	2	
21	90105-08059	BOLT, FLANGE	3	3	3	3	
22	90179-08674	NUT	3	3	3	3	
23	90201-08730	WASHER, PLATE	3	3	3	3	
24	90105-10072	BOLT, FLANGE	1	1	1	1	
25	90179-10658	NUT	1	1	1	1	
26	92907-10200	WASHER, PLAIN	1	1	1	1	
27	1C3-21244-00	NUT	2	2	2	2	

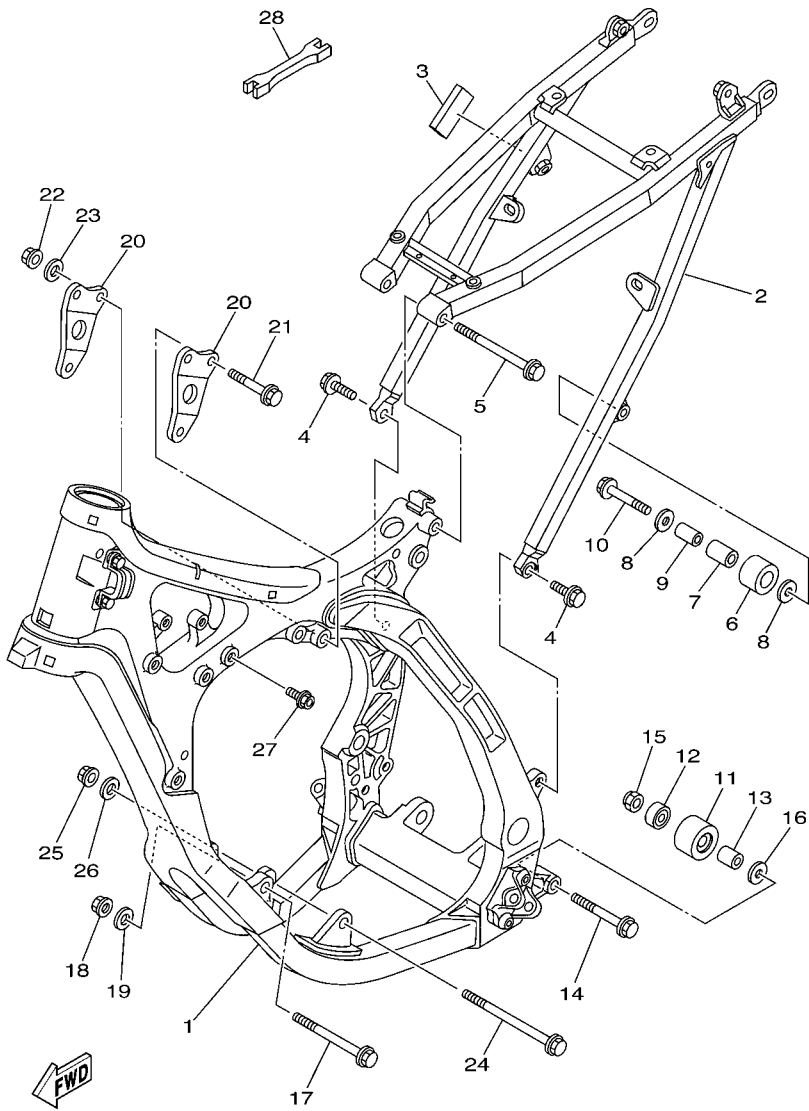

1C31100-D160

FIG. 16 FRAME

REF. NO.	PART NO.	DESCRIPTION	1C31	1C32	1C33	1C34	REMARKS
28	5ET-28166-00	WRENCH, HEXAGON	1	1	1	1	

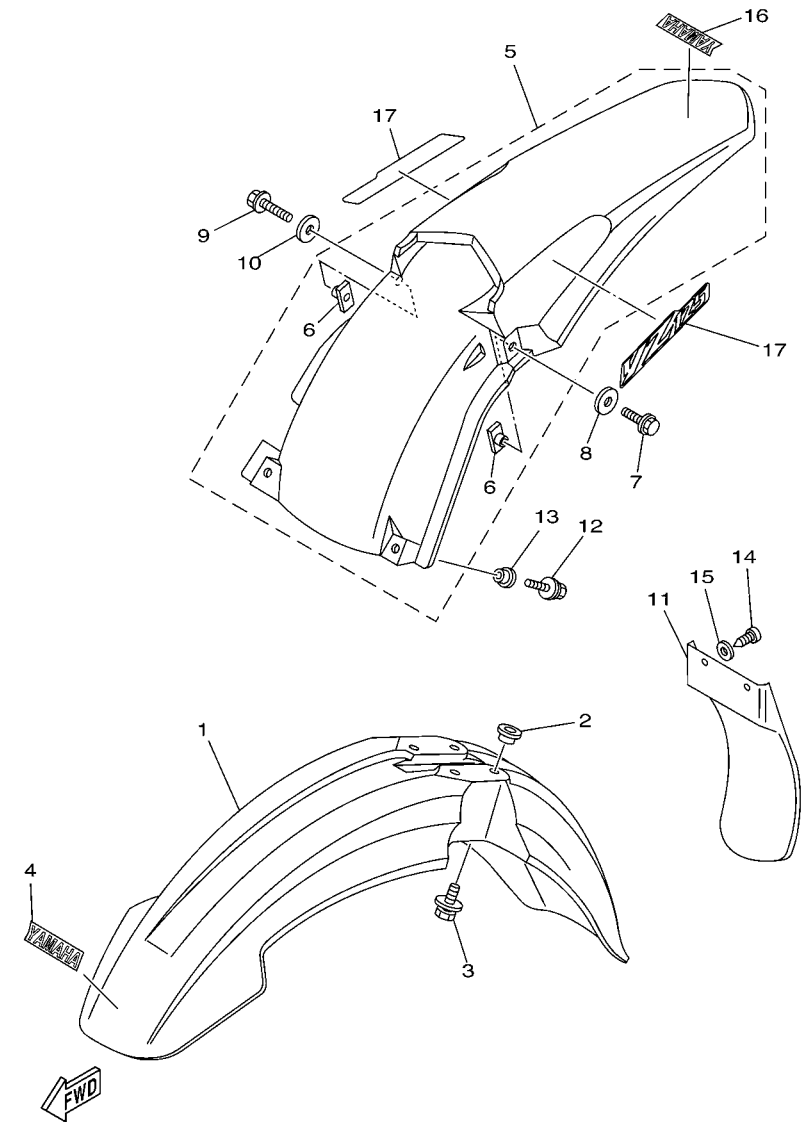

5XE1100-C170

FIG. 17 FENDER

REF. NO.	PART NO.	DESCRIPTION	1C31	1C32	1C33	1C34	REMARKS
1	5HD-21511-00	FENDER, FRONT	1	1	1	1	
2	90387-06090	COLLAR	4	4	4	4	
3	90119-06096	BOLT, WITH WASHER	4	4	4	4	
4	4ES-2153E-01	EMBLEM, YAMAHA	1	1	1	1	
5	5XE-21610-00	REAR FENDER COMP.	1	1	1	1	
6	5XE-21635-00	.NUT, REAR FENDER	2	2	2	2	
7	90105-06045	BOLT, FLANGE	1	1	1	1	
8	90201-062A8	WASHER, PLATE	1	1	1	1	
9	90105-06046	BOLT, FLANGE	1	1	1	1	
10	90201-06071	WASHER, PLATE	1	1	1	1	
11	5UN-21642-00	GUARD, FLAP	1	1	1	1	
12	90119-06225	BOLT, WITH WASHER	2	2	2	2	
13	90387-06009	COLLAR	2	2	2	2	
14	97707-60016	SCREW, TAPPING	2	2	2	2	
15	90201-06557	WASHER, PLATE	2	2	2	2	
16	4ES-2153E-01	EMBLEM, YAMAHA	1	1	1	1	
17	5XE-2163G-00	EMBLEM 1	2	2	2	2	

FIG. 18 SIDE COVER

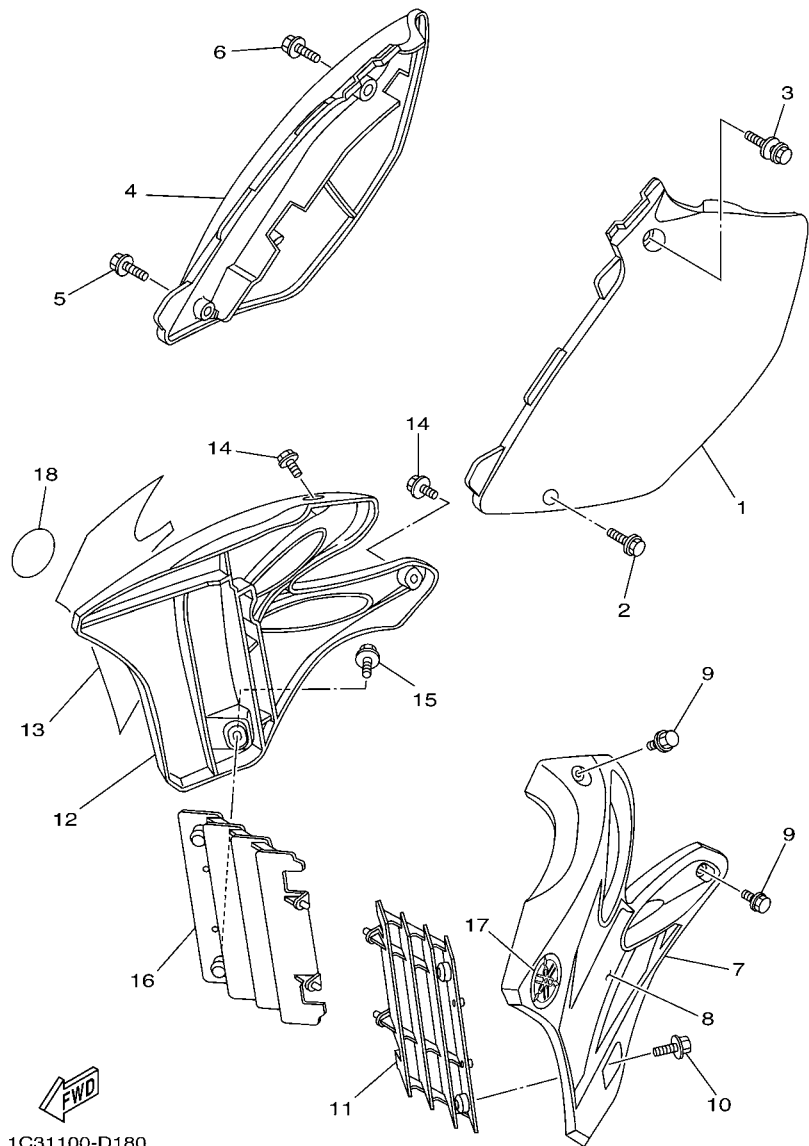

1C31100-D180

REF. NO.	PART NO.	DESCRIPTION	1C31	1C32	1C33	1C34	REMARKS
1	5NY-21711-00	COVER, SIDE 1	1	1	1	1	
2	95827-06016	BOLT, FLANGE	1	1	1	1	
3	90119-08238	BOLT, WITH WASHER	1	1	1	1	
4	5NY-21721-00	COVER, SIDE 2	1	1	1	1	
5	95827-06016	BOLT, FLANGE	1	1	1	1	
6	90119-08238	BOLT, WITH WASHER	1	1	1	1	
7	5XE-21730-00	SIDE COVER ASSY 3	1	1	1	1	
8	1C3-2173E-00	GRAPHIC 1	1	1	1	1	
9	90105-06055	BOLT, FLANGE	2	2	2	2	
10	90159-06078	SCREW, WITH WASHER	1	1	1	1	
11	5NL-2172A-11	PANEL 1	1	1	1	1	
12	5XE-21740-00	SIDE COVER ASSY 4	1	1	1	1	
13	1C3-2173F-00	GRAPHIC 2	1	1	1	1	
14	90105-06055	BOLT, FLANGE	2	2	2	2	
15	90159-06078	SCREW, WITH WASHER	1	1	1	1	
16	5NL-2172A-11	PANEL 1	1	1	1	1	
17	5MV-2175C-00	TUNING FORK MARK	1	1	1	1	
18	5MV-2175C-00	TUNING FORK MARK	1	1	1	1	

FIG. 19 REAR ARM

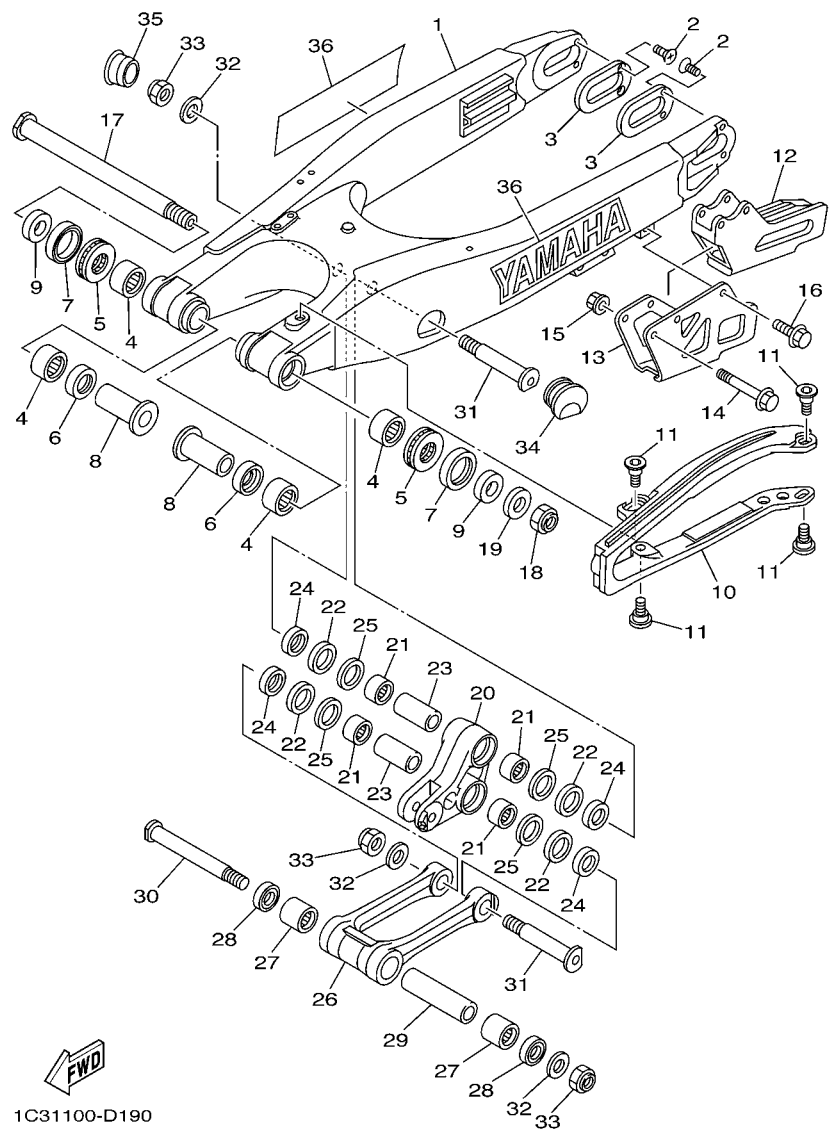

REF. NO.	PART NO.	DESCRIPTION	1C31	1C32	1C33	1C34	REMARKS
1	1C3-22110-00	REAR ARM COMP.	1	1	1	1	
2	90151-04001	SCREW, COUNTERSUNK	4	4	4	4	
3	1C3-22355-00	PATCH	2	2	2	2	
4	93317-22262	BEARING	4	4	4	4	
5	93342-22217	BEARING	2	2	2	2	
6	93106-22019	OIL SEAL (DC 22-28-8)	2	2	2	2	
7	93109-28043	OIL SEAL	2	2	2	2	
8	90387-18008	COLLAR	2	2	2	2	
9	90387-18009	COLLAR	2	2	2	2	
10	1C3-22151-00	SEAL, GUARD	1	1	1	1	
11	1C3-22969-00	SCREW, 1	4	4	4	4	
12	1C3-22199-00	SUPPORT, CHAIN	1	1	1	1	
13	1C3-22128-00	COVER, THRUST 1	1	1	1	1	
14	95027-06050	BOLT, FLANGE	2	2	2	2	
15	90179-06568	NUT	2	2	2	2	
16	95027-06010	BOLT, FLANGE	1	1	1	1	
17	1C3-22141-00	SHAFT, PIVOT	1	1	1	1	
18	90185-16127	NUT, SELF-LOCKING	1	1	1	1	
19	90201-160F6	WASHER, PLATE	1	1	1	1	
20	1C3-2217A-00	ARM, RELAY	1	1	1	1	
21	93315-32166	BEARING	4	4	4	4	
22	93109-25001	OIL SEAL	4	4	4	4	
23	90387-16010	COLLAR	2	2	2	2	
24	90209-16008	WASHER	4	4	4	4	
25	90201-21013	WASHER, PLATE	4	4	4	4	
26	1C3-2217F-00	ROD, CONNECTING 1	1	1	1	1	
27	93315-32165	BEARING	2	2	2	2	

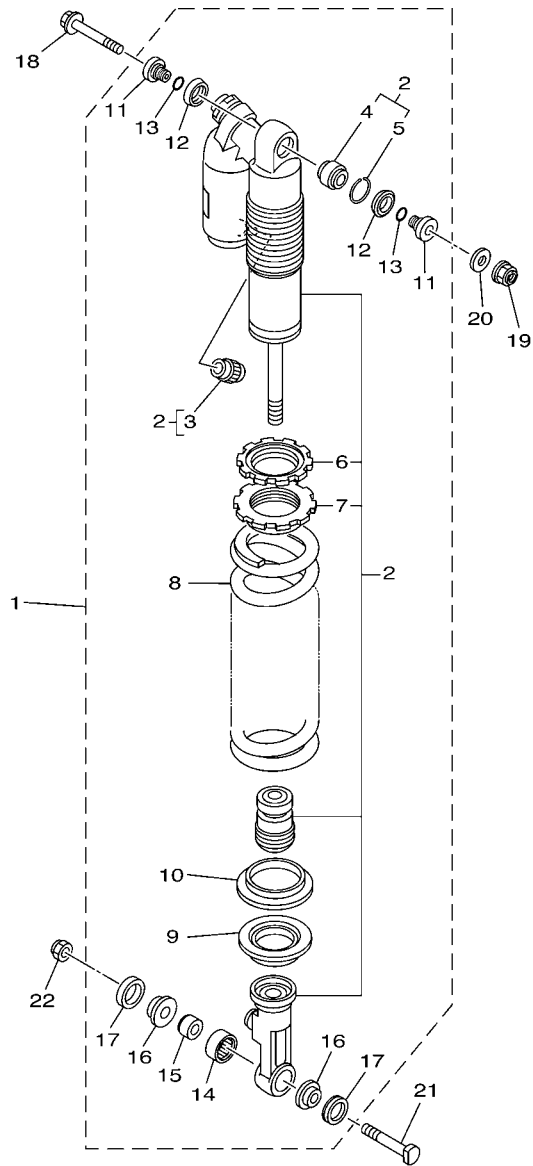

 1C31100-D200

FIG. 20 REAR SUSPENSION

REF. NO.	PART NO.	DESCRIPTION	1C31	1C32	1C33	1C34	REMARKS
1	1C3-22210-00	SHOCK ABSORBER ASSY, REAR	1				UR USA
	1C3-22210-30	SHOCK ABSORBER ASSY, REAR	1				UR FOR CAN
	1C3-22210-40	SHOCK ABSORBER ASSY, REAR	1			1	UR FOR ZAF
	1C3-22210-10	SHOCK ABSORBER ASSY, REAR		1			
	1C3-22210-20	SHOCK ABSORBER ASSY, REAR			1		
2	1C3-22201-00	.DAMPER SUB ASSY	1				UR USA
	1C3-22201-30	.DAMPER SUB ASSY	1				UR FOR CAN
	1C3-22201-40	.DAMPER SUB ASSY	1			1	UR FOR ZAF
	1C3-22201-10	.DAMPER SUB ASSY		1			
	1C3-22201-20	.DAMPER SUB ASSY			1		
3	509-23184-L0	..CAP, AIR VALVE	1	1	1	1	
4	4JX-22226-00	..BUSH, SHOCK ABSORBER LOWER	1	1	1	1	
5	5DH-23183-00	..CIRCLIP	1	1	1	1	
6	3SP-22234-00	..GUIDE, SPRING 3	1	1	1	1	
7	3SP-22213-00	..SEAT, SPRING UPPER	1	1	1	1	
8	5UN-22212-20	.SPRING (K=46N/MM)	1	1	1	1	
9	5XE-22214-00	.GUIDE, SPRING 1	1	1	1	1	
10	5MV-22224-00	.GUIDE, SPRING 2	1	1	1	1	
11	1C3-22253-00	.COLLAR, DISTANCE	2	2	2	2	
12	3JE-22475-00	.SEAL, DUST	2	2	2	2	
13	4EW-22474-00	.SEAL, RING	2	2	2	2	
14	5UN-22176-00	.BEARING	1	1	1	1	
15	5MV-22184-00	.BUSH	1	1	1	1	
16	5MV-22253-00	.COLLAR, DISTANCE	2	2	2	2	
17	5NY-22475-00	.SEAL, DUST	2	2	2	2	
18	5XE-22242-00	BOLT 2	1	1	1	1	
19	95607-10200	NUT, U FLANGE	1	1	1	1	

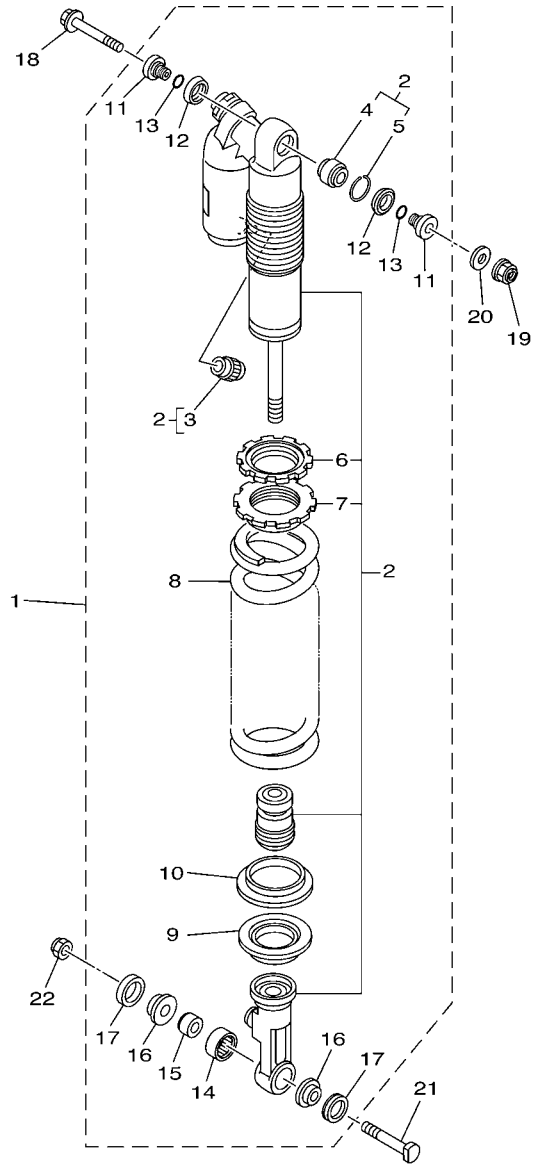

1C31100-D200

FIG. 20 REAR SUSPENSION

REF. NO.	PART NO.	DESCRIPTION	1C31	1C32	1C33	1C34	REMARKS
20	92907-10200	WASHER, PLAIN	1	1	1	1	
21	5NY-22241-00	BOLT 1	1	1	1	1	
22	90185-10060	NUT, SELF-LOCKING	1	1	1	1	

FIG. 21 STEERING

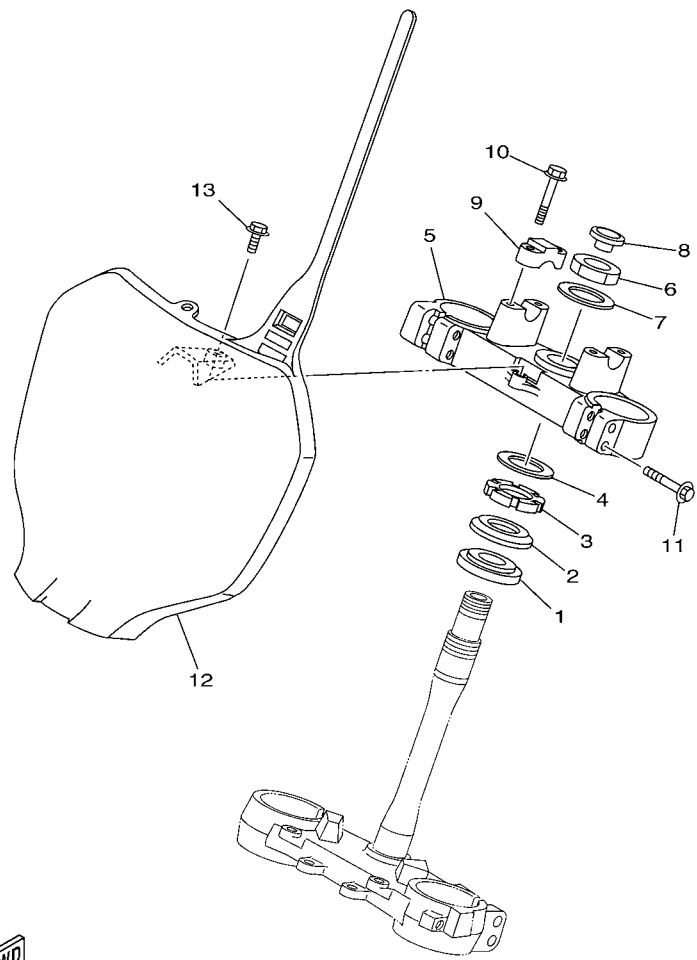

REF. NO.	PART NO.	DESCRIPTION	1C31	1C32	1C33	1C34	REMARKS
1	93332-00068	BEARING	1	1	1	1	
2	4EW-23416-00	COVER, BALL RACE 2	1	1	1	1	
3	90179-28003	NUT	1	1	1	1	
4	90201-286K9	WASHER, PLATE	1	1	1	1	
5	5XE-23435-20	CROWN, HANDLE	1	1	1	1	
6	5TA-23357-00	NUT	1	1	1	1	
7	90201-247L2	WASHER, PLATE	1	1	1	1	
8	5TJ-2319U-00	CAP	1	1	1	1	
9	5XE-23441-00	HOLDER, HANDLE UPPER	2	2	2	2	
10	95027-08035	BOLT, FLANGE	4	4	4	4	
11	95027-08040	BOLT, FLANGE	4	4	4	4	
12	1C3-23485-10	PLATE, NUMBER	1	1	1	1	
13	90119-06225	BOLT, WITH WASHER	1	1	1	1	

1C31100-D210

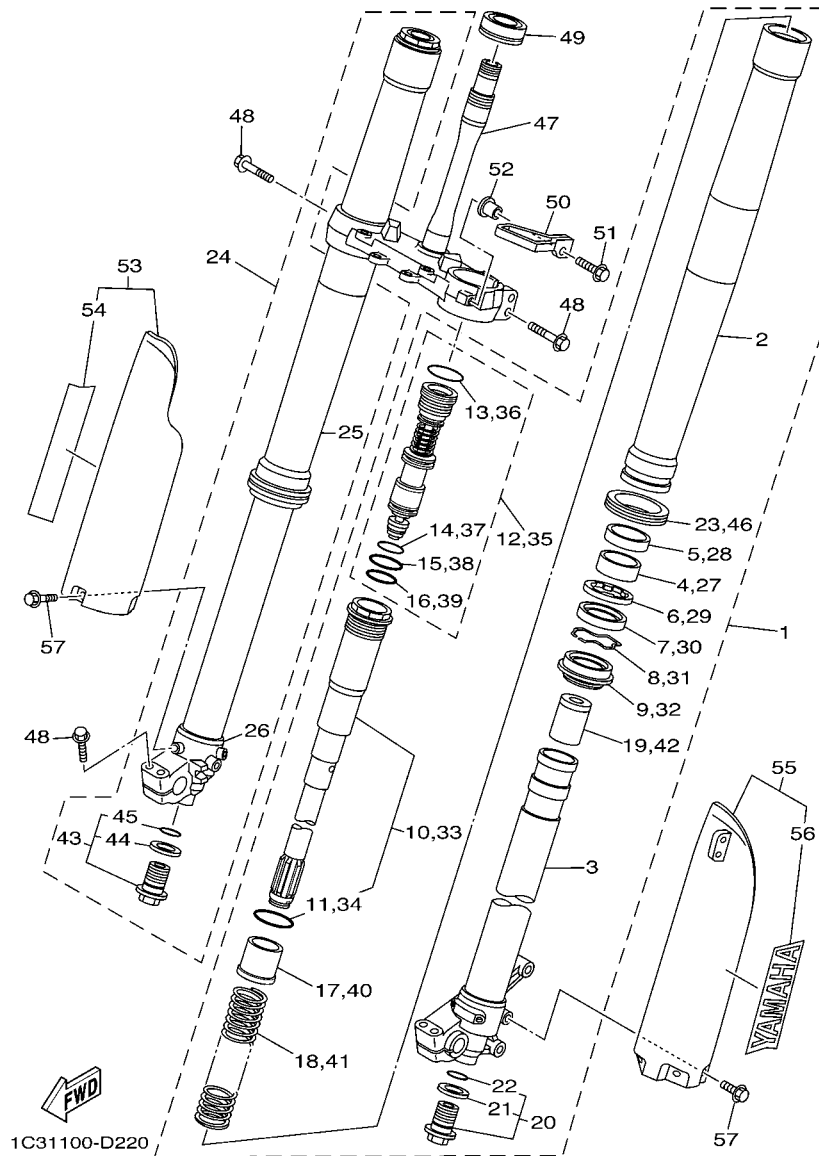

FIG. 22 FRONT FORK

REF. NO.	PART NO.	DESCRIPTION	1C31	1C32	1C33	1C34	REMARKS
1	1C3-23102-00	FRONT FORK ASSY (L.H)	1			1	
	1C3-23102-10	FRONT FORK ASSY (L.H)		1	1		
2	1C3-23136-L0	.TUBE, OUTER	1	1	1	1	
3	1C3-23120-L0	.INNER TUBE COMP.2	1	1	1	1	
4	5XE-23171-L0	.PISTON, FRONT FORK	1	1	1	1	
5	5XE-23125-L0	.METAL, SLIDE 1	1	1	1	1	
6	5XE-23146-L0	.WASHER, OIL SEAL	1	1	1	1	
7	1C3-23145-L0	.OIL SEAL	1	1	1	1	
8	5XE-23153-L0	.RING, SNAP	1	1	1	1	
9	5XE-23144-L0	.SEAL, DUST	1	1	1	1	
10	1C3-23170-L0	.CYLINDER COMP., FRONT FORK	1			1	
	1C3-23170-M0	.CYLINDER COMP., FRONT FORK		1	1		
11	1C3-23147-L0	..O-RING	1	1	1	1	
12	1C3-2316A-L0	.VALVE COMP.	1			1	
	1C3-2316A-M0	.VALVE COMP.		1	1		
13	1C3-23188-L0	..O-RING	1	1	1	1	
14	5UX-23188-00	..O-RING	1	1	1	1	
15	43F-23188-10	..O-RING	1	1	1	1	
16	1C3-23188-M0	..O-RING	1	1	1	1	
17	1C3-23118-L0	.SPACER	1	1	1	1	
18	1C3-23141-L0	.SPRING, FRONT FORK(K=4.1N/MM)	1			1	
	1C3-23141-M0	.SPRING, FRONT FORK(K=4.0N/MM)		1	1		
19	1C3-2316E-L0	.SPACER	1	1	1	1	
20	1C3-23111-L0	.BOLT, CAP	1	1	1	1	
21	2HH-23158-L0	..GASKET	1	1	1	1	
22	276-23114-00	..GASKET	1	1	1	1	
23	1C3-2314F-L0	.PROTECTOR GUIDE COMP., 1	1	1	1	1	

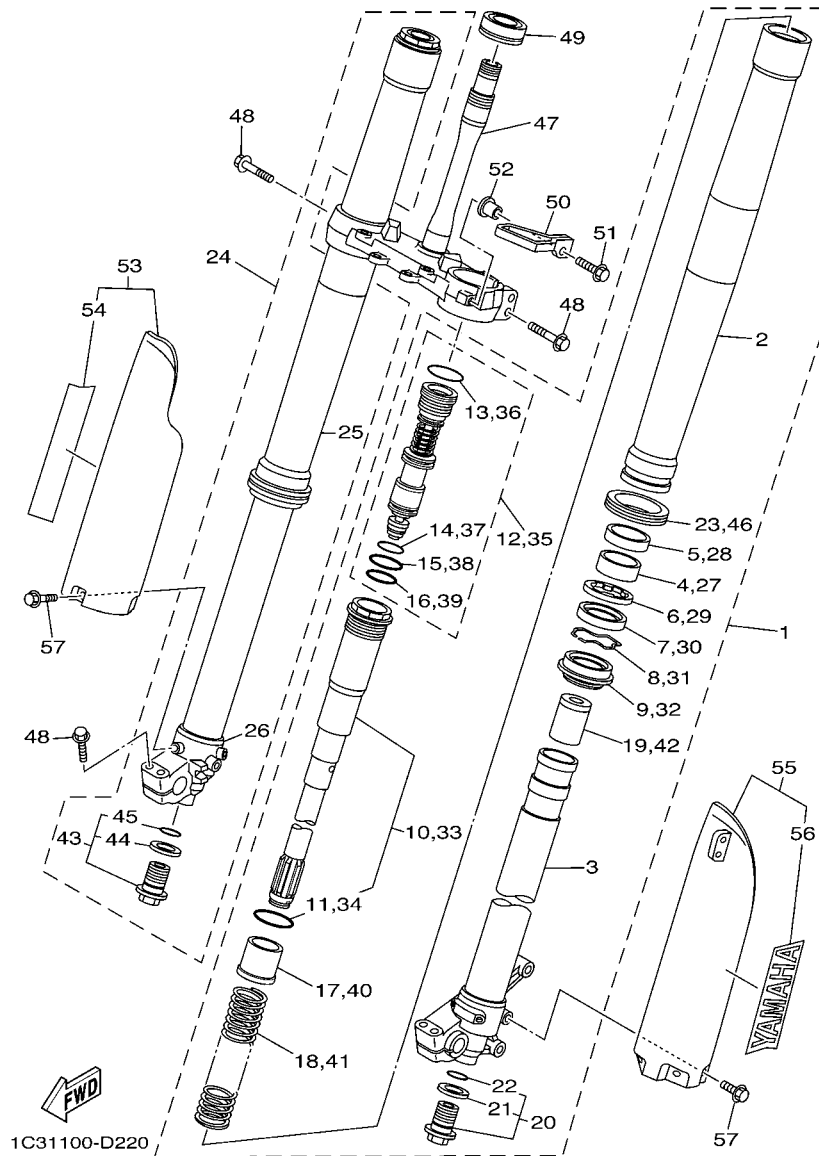
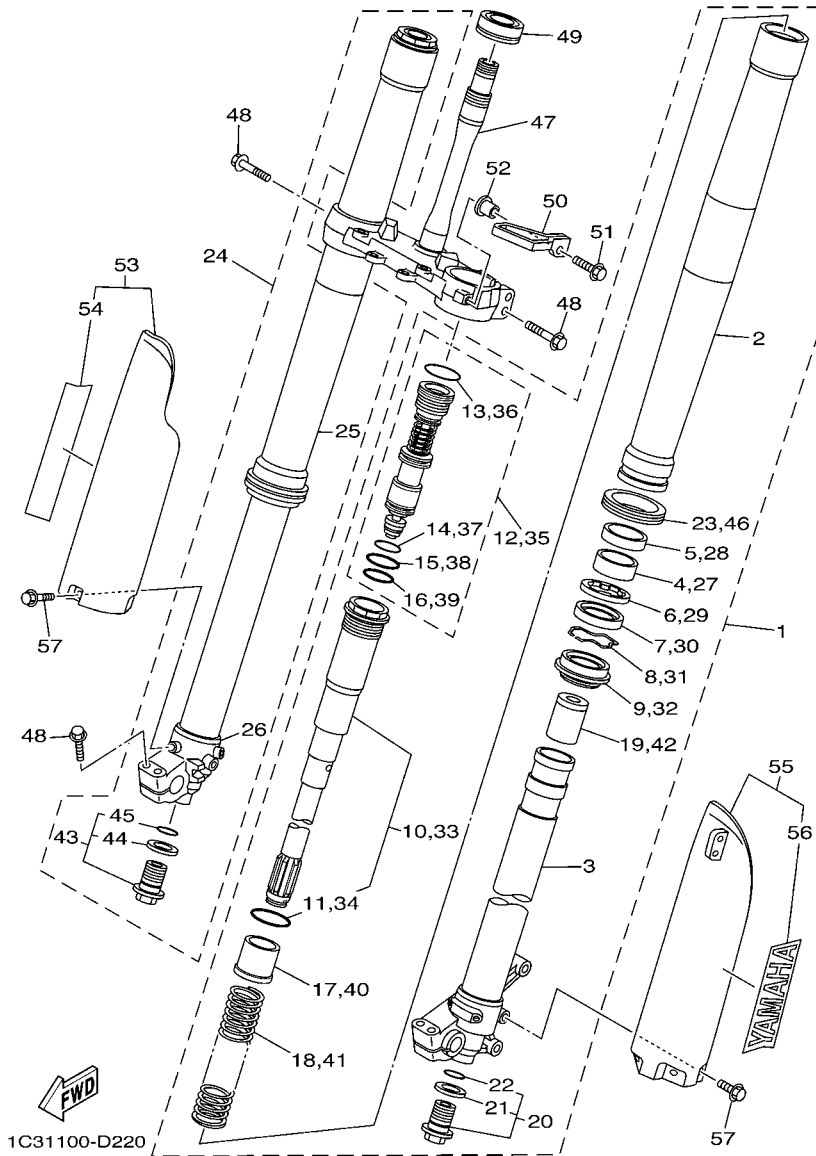

FIG. 22 FRONT FORK

REF. NO.	PART NO.	DESCRIPTION	1C31	1C32	1C33	1C34	REMARKS
24	1C3-23103-00	FRONT FORK ASSY (R.H)	1			1	
	1C3-23103-10	FRONT FORK ASSY (R.H)		1	1		
25	1C3-23136-L0	.TUBE, OUTER	1	1	1	1	
26	1C3-23110-L0	.INNER TUBE COMP.1	1	1	1	1	
27	5XE-23171-L0	.PISTON, FRONT FORK	1	1	1	1	
28	5XE-23125-L0	.METAL, SLIDE 1	1	1	1	1	
29	5XE-23146-L0	.WASHER, OIL SEAL	1	1	1	1	
30	1C3-23145-L0	.OIL SEAL	1	1	1	1	
31	5XE-23153-L0	.RING, SNAP	1	1	1	1	
32	5XE-23144-L0	.SEAL, DUST	1	1	1	1	
33	1C3-23170-L0	.CYLINDER COMP., FRONT FORK	1			1	
	1C3-23170-M0	.CYLINDER COMP., FRONT FORK		1	1		
34	1C3-23147-L0	..O-RING	1	1	1	1	
35	1C3-2316A-L0	.VALVE COMP.	1			1	
	1C3-2316A-M0	.VALVE COMP.			1	1	
36	1C3-23188-L0	..O-RING	1	1	1	1	
37	5UX-23188-00	..O-RING	1	1	1	1	
38	43F-23188-10	..O-RING	1	1	1	1	
39	1C3-23188-M0	..O-RING	1	1	1	1	
40	1C3-23118-L0	.SPACER	1	1	1	1	
41	1C3-23141-L0	.SPRING, FRONT FORK(K=4.1N/MM)	1			1	
	1C3-23141-M0	.SPRING, FRONT FORK(K=4.0N/MM)		1	1		
42	1C3-2316E-L0	.SPACER	1	1	1	1	
43	1C3-23111-L0	.BOLT, CAP	1	1	1	1	
44	2HH-23158-L0	..GASKET	1	1	1	1	
45	276-23114-00	..GASKET	1	1	1	1	
46	1C3-2314F-L0	.PROTECTOR GUIDE COMP., 1	1	1	1	1	



1C31100-D220

FIG. 22 FRONT FORK

REF. NO.	PART NO.	DESCRIPTION	1C31	1C32	1C33	1C34	REMARKS
47	1C3-23340-L0	UNDER BRACKET COMP.	1	1	1	1	
48	5NY-23346-L0	BOLT 1	8	8	8	8	
49	93332-00081	BEARING	1	1	1	1	
50	5XE-23389-00	GUIDE, CABLE	1	1	1	1	
51	95027-06020	BOLT, FLANGE	1	1	1	1	
52	5XE-23113-00	COLLAR	1	1	1	1	
53	1C3-2314J-00	PROTECTOR COMP., 2	1	1	1	1	
54	4XL-2153A-10	.EMBLEM, YAMAHA	1	1	1	1	
55	1C3-2314H-00	PROTECTOR COMP., 1	1	1	1	1	
56	4XL-2153A-10	.EMBLEM, YAMAHA	1	1	1	1	
57	3SP-23356-L0	BOLT 2	6	6	6	6	

FIG. 23 FUEL TANK

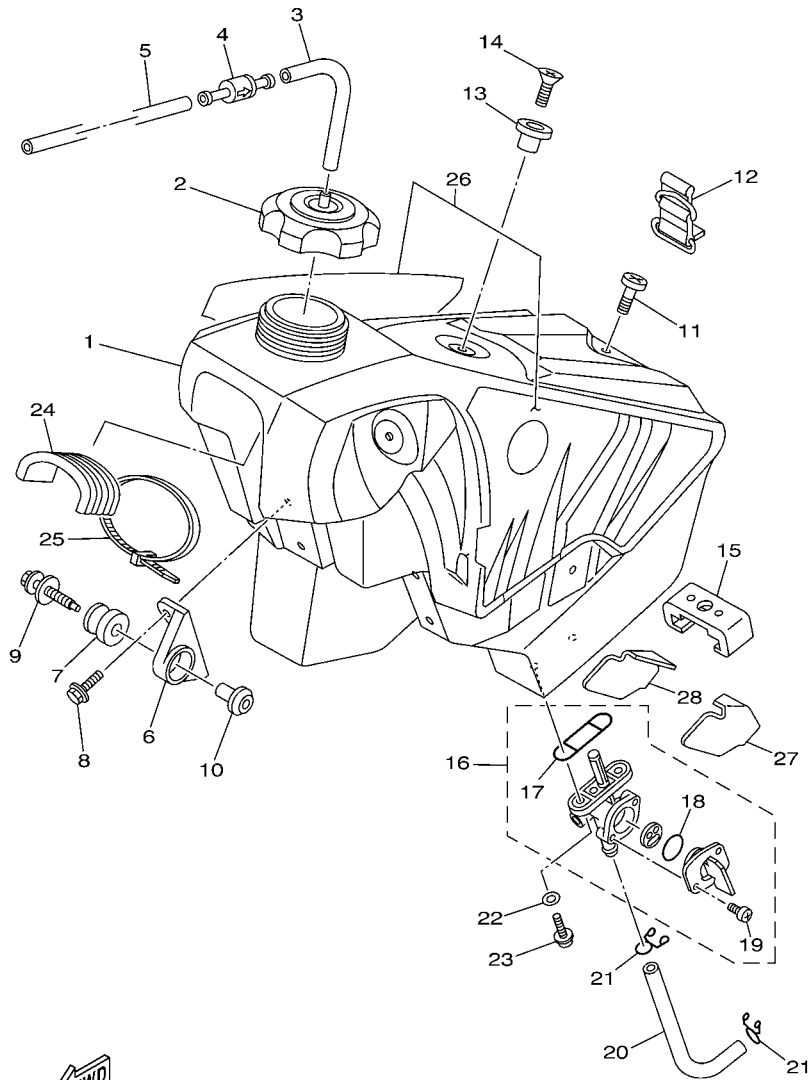

1C31100-D230

REF. NO.	PART NO.	DESCRIPTION	1C31	1C32	1C33	1C34	REMARKS
1	1C3-24110-00	FUEL TANK COMP.	1	1	1	1	
2	5NY-24610-00	CAP ASSY	1	1	1	1	
3	90445-09220	HOSE (L30)	1	1	1	1	
4	3XJ-24380-00	PIPE JOINT ASSY	1	1	1	1	
5	90445-09025	HOSE	1	1	1	1	
6	5XE-24144-00	HOLDER, DAMPER	2	2	2	2	
7	90480-18549	GROMMET	2	2	2	2	
8	95027-06016	BOLT, FLANGE	4	4	4	4	
9	5XE-24176-00	BOLT 1	2	2	2	2	
10	5NY-24186-00	WASHER, SPECIAL	2	2	2	2	
11	98907-06025	SCREW, BIND	1	1	1	1	
12	3SP-24173-00	BAND, TANK FITTING 1	1	1	1	1	
13	4EW-2412F-00	BRACKET, SEAT	1	1	1	1	
14	98707-06025	SCREW, FLAT HEAD	1	1	1	1	
15	1C3-24181-00	DAMPER, LOCATING 1	1	1	1	1	
16	3JD-24500-02	FUEL COCK ASSY 1	1	1	1	1	
17	4X8-24512-00	.O-RING	1	1	1	1	
18	3AJ-24534-01	.SEAL, COCK	1	1	1	1	
19	98507-03008	.SCREW, PAN HEAD	2	2	2	2	
20	90445-111J0	HOSE (L145)	1	1	1	1	
21	90467-10008	CLIP	2	2	2	2	
22	90202-05193	WASHER, PLATE	2	2	2	2	
23	90149-06011	SCREW	2	2	2	2	
24	1C3-24182-00	DAMPER, LOCATING 2	1	1	1	1	
25	90465-13275	CLAMP	1	1	1	1	
26	1C3-24240-00	GRAPHIC SET	1	1	1	1	
27	1C3-24183-00	DAMPER, LOCATING 3	1	1	1	1	

FIG. 23 FUEL TANK

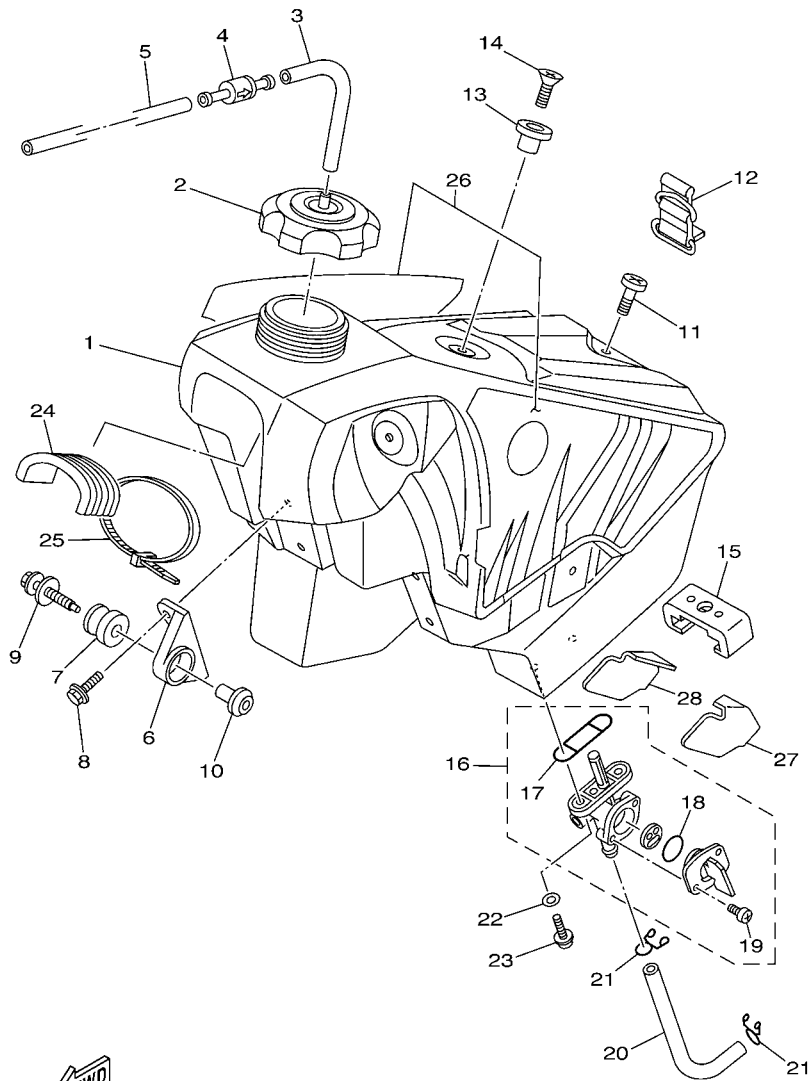

1C31100-D230

REF. NO.	PART NO.	DESCRIPTION	1C31	1C32	1C33	1C34	REMARKS
28	1C3-24184-00	DAMPER, LOCATING 4	1	1	1	1	

FIG. 25 FRONT WHEEL

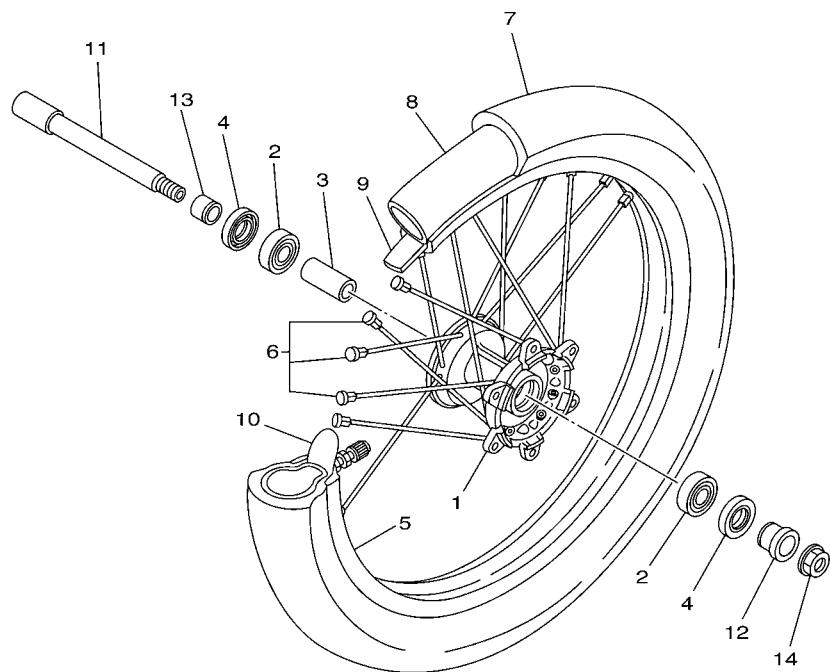

REF. NO.	PART NO.	DESCRIPTION	1C31	1C32	1C33	1C34	REMARKS
1	5NY-25111-00	HUB, FRONT	1	1	1	1	
2	93306-90403	BEARING	2	2	2	2	
3	5NY-25117-00	SPACER, BEARING	1	1	1	1	
4	93102-26468	OIL SEAL	2	2	2	2	
5	94416-21003	RIM (1.60-21)	1	1	1	1	
6	5NY-25104-00	SPOKE SET, FRONT	1	1	1	1	
7	94108-2112Y	TIRE (80/100-21 51M D755F)	1	1			DUNLOP FOR CAN
	94108-21015	TIRE (80/100-21 51M D739FA)	1			1	DUNLOP EXCEPT CAN
	94108-21012	TIRE(80/100-21 51M M601)			1		BRIDGESTONE
8	94227-21101	TUBE (80/100-21 M/C TR4)	1	1		1	DUNLOP
	94209-21229	TUBE (80/100-21 M/C TR4)			1		BRIDGESTONE
9	94309-21161	BAND, RIM (1.60-21)	1	1		1	DUNLOP
	94330-21084	BAND,RIM (1.60-21)			1		BRIDGESTONE
10	5SF-25394-00	SPACER, BEAD	1	1	1	1	
11	1C3-25181-00	AXLE, WHEEL	1	1	1	1	
12	5NY-25183-00	COLLAR, WHEEL	1	1	1	1	
13	5NY-25186-00	COLLAR, WHEEL	1	1	1	1	
14	90179-16002	NUT	1	1	1	1	



1C31100-D250

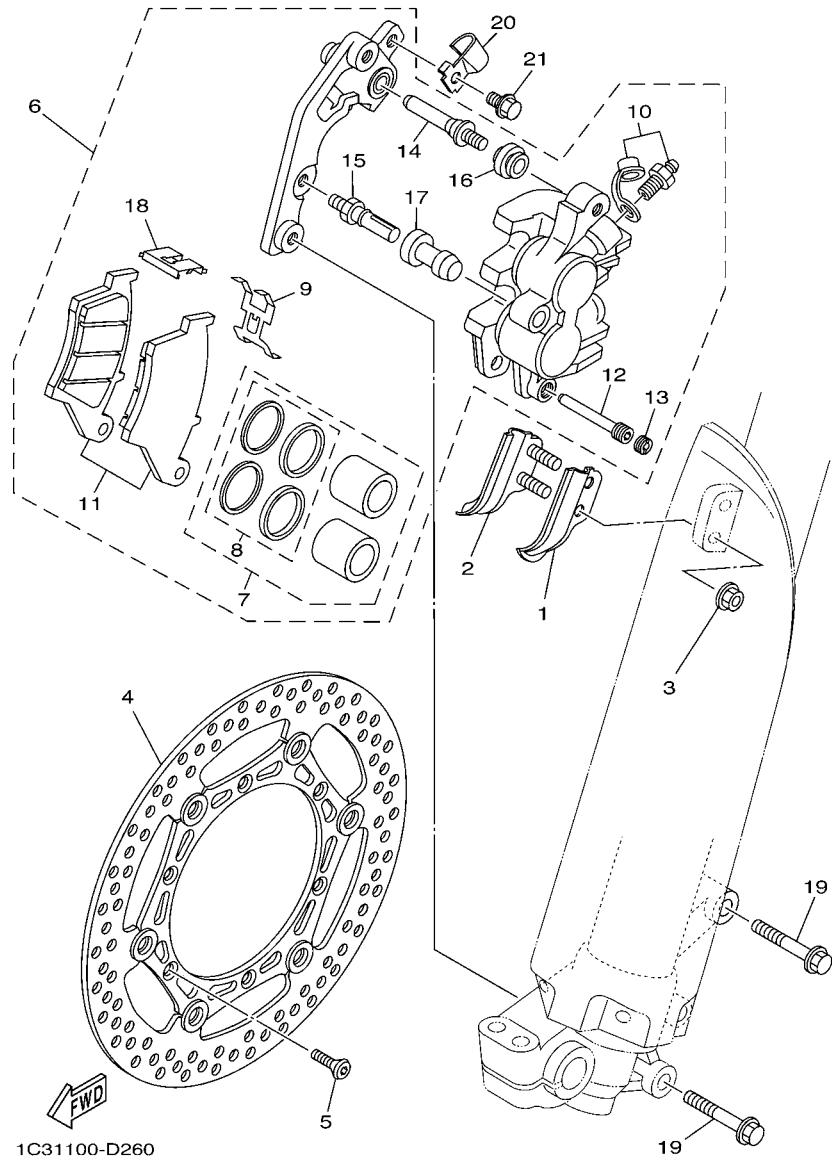
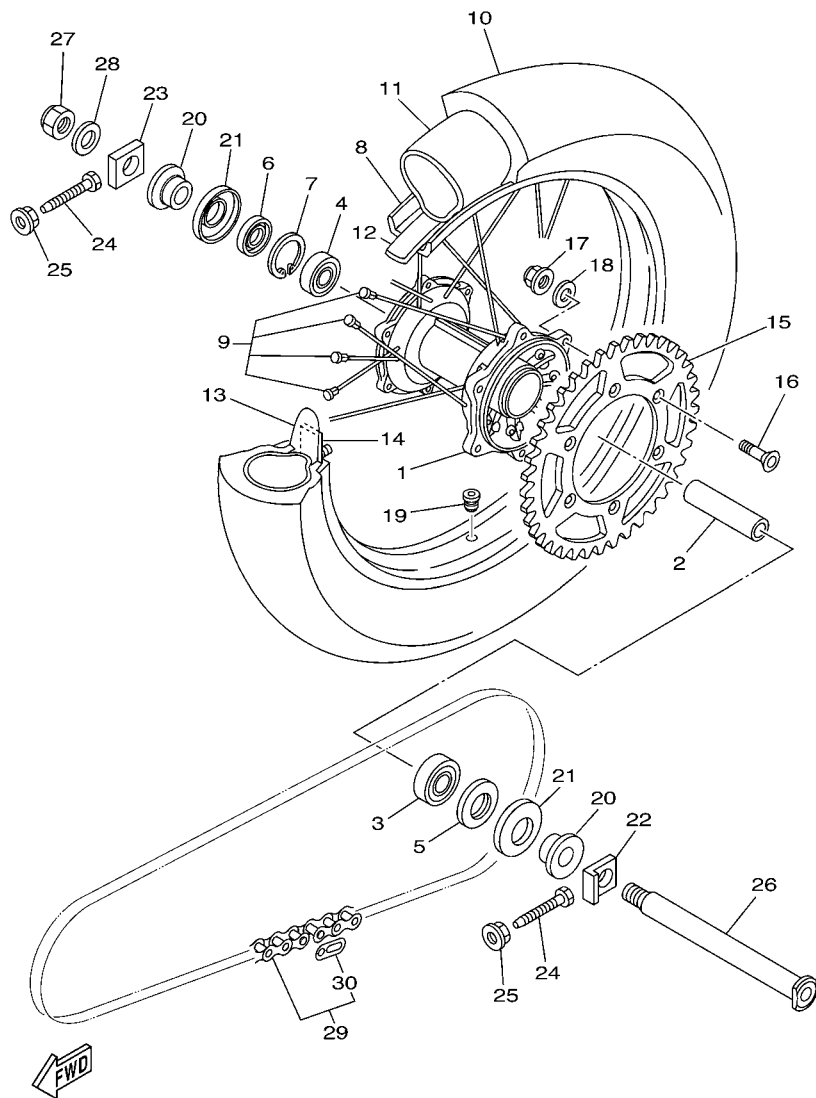

FIG. 26 FRONT BRAKE CALIPER

REF. NO.	PART NO.	DESCRIPTION	1C31	1C32	1C33	1C34	REMARKS
1	1C3-23466-00	CLAMP	1	1	1	1	
2	1C3-23467-00	CLAMP	1	1	1	1	
3	95707-06500	NUT, FLANGE	2	2	2	2	
4	5MV-2581T-00	DISK BRAKE ASSY	1	1	1	1	
5	90149-06327	SCREW	6	6	6	6	
6	1C3-2580T-00	CALIPER ASSY (LEFT)	1	1	1	1	
7	5UN-W0057-00	.PISTON ASSY, CALIPER	1	1	1	1	
8	3JD-W0047-00	..CALIPER SEAL KIT	1	1	1	1	
9	5DH-25919-00	.SUPPORT, PAD	1	1	1	1	
10	1UY-W0048-50	.BLEED SCREW KIT	1	1	1	1	
11	5MV-W0045-01	.BRAKE PAD KIT	1	1	1	1	
12	5DH-25933-00	.PIN, PAD	1	1	1	1	
13	5DH-25916-00	.PLUG	1	1	1	1	
14	3SP-25926-51	.BOLT	1	1	1	1	
15	3SP-25914-51	.PIN, SLIDE	1	1	1	1	
16	3JD-25917-00	.BOOT, CALIPER	1	1	1	1	
17	1UY-25937-51	.BOOT 2	1	1	1	1	
18	5DH-25849-00	.RETAINER, CALIPER	1	1	1	1	
19	90105-08659	BOLT, FLANGE	2	2	2	2	
20	1C3-25875-00	HOLDER, BRAKE HOSE 1	1	1	1	1	
21	95027-06010	BOLT, FLANGE	1	1	1	1	

FIG. 27 REAR WHEEL



5NY1100-A271

REF. NO.	PART NO.	DESCRIPTION	1C31	1C32	1C33	1C34	REMARKS
1	5ET-25311-00	HUB, REAR	1	1	1	1	
2	5ET-25317-00	SPACER, BEARING	1	1	1	1	
3	93306-27205	BEARING	1	1	1	1	
4	93306-07202	BEARING	1	1	1	1	
5	93106-30044	OIL SEAL	1	1	1	1	
6	93106-30045	OIL SEAL	1	1	1	1	
7	99009-45500	CIRCLIP	1	1	1	1	
8	94418-19601	RIM (1.85-19)	1	1	1	1	
9	5HD-25304-00	SPOKE SET, REAR	1	1	1	1	
10	94110-1913B	TIRE (100/90-19 57M D755)	1	1			DUNLOP EXCEPT CAN
	94110-19011	TIRE (100/90-19 57M D739)	1			1	DUNLOP FOR CAN
	94110-19009	TIRE(100/90-19 51M M602)			1		BRIDGESTONE
11	94210-19224	TUBE (100/90-19 M/C TR4 BTL)	1	1		1	DUNLOP
	94210-19222	TUBE (100/90-19 M/C TR4)				1	BRIDGESTONE
12	94321-19135	BAND, RIM (1.85-19)	1	1		1	DUNLOP
	94316-19156	BAND, RIM (1.85-19)				1	BRIDGESTONE
13	4XM-25394-00	SPACER, BEAD	1	1	1	1	
14	4XM-25364-00	DAMPER	1	1	1	1	
15	1C3-25448-00	SPROCKET, DRIVEN (48T)	1	1	1	1	STD
	1C3-25447-00	SPROCKET, DRIVEN (47T)	1	1	1	1	AP
	1C3-25449-00	SPROCKET, DRIVEN (49T)	1	1	1	1	AP
	1C3-25450-00	SPROCKET, DRIVEN (50T)	1	1	1	1	AP
	1C3-25451-00	SPROCKET, DRIVEN (51T)	1	1	1	1	AP
	1C3-25452-00	SPROCKET, DRIVEN (52T)	1	1	1	1	AP
16	90109-081G1	BOLT	6	6	6	6	
17	90185-08169	NUT, SELF-LOCKING	6	6	6	6	
18	90201-08326	WASHER, PLATE	6	6	6	6	

D10

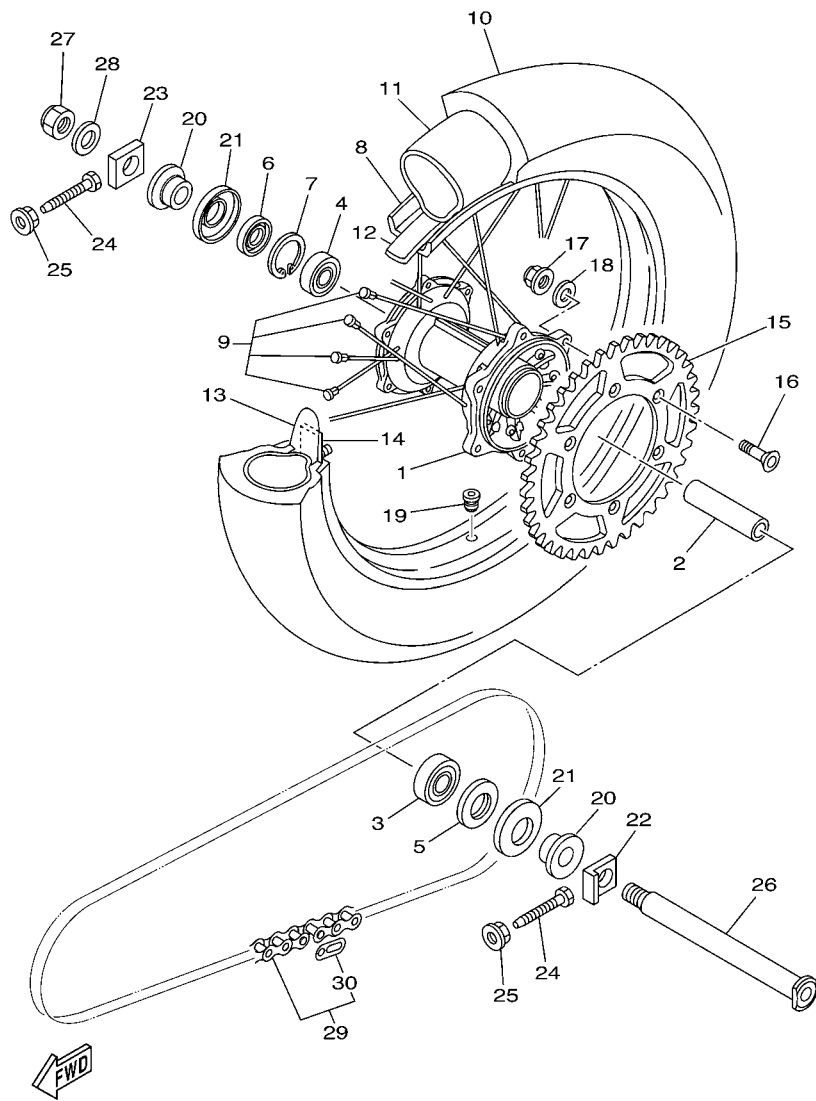

5NY1100-A271

FIG. 27 REAR WHEEL

REF. NO.	PART NO.	DESCRIPTION	1C31	1C32	1C33	1C34	REMARKS
19	90480-08608	GROMMET	1	1	1	1	
20	5UN-25383-00	COLLAR, WHEEL	2	2	2	2	
21	5ET-25367-00	COVER, HUB DUST	2	2	2	2	
22	1C3-25388-00	PULLER, CHAIN 1	1	1	1	1	
23	1C3-25389-00	PULLER, CHAIN 2	1	1	1	1	
24	90101-08777	BOLT	2	2	2	2	
25	90179-08299	NUT	2	2	2	2	
26	1C3-25381-00	AXLE, WHEEL	1	1	1	1	
27	90185-20168	NUT, SELF-LOCKING	1	1	1	1	
28	90201-203U1	WASHER, PLATE	1	1	1	1	
29	9Y581-92111	CHAIN (DID 520D 112L)	1	1	1	1	
30	94681-68001	.JOINT,CHAIN (DID 520DM-RJ)	1	1	1	1	

FIG. 28 REAR BRAKE CALIPER

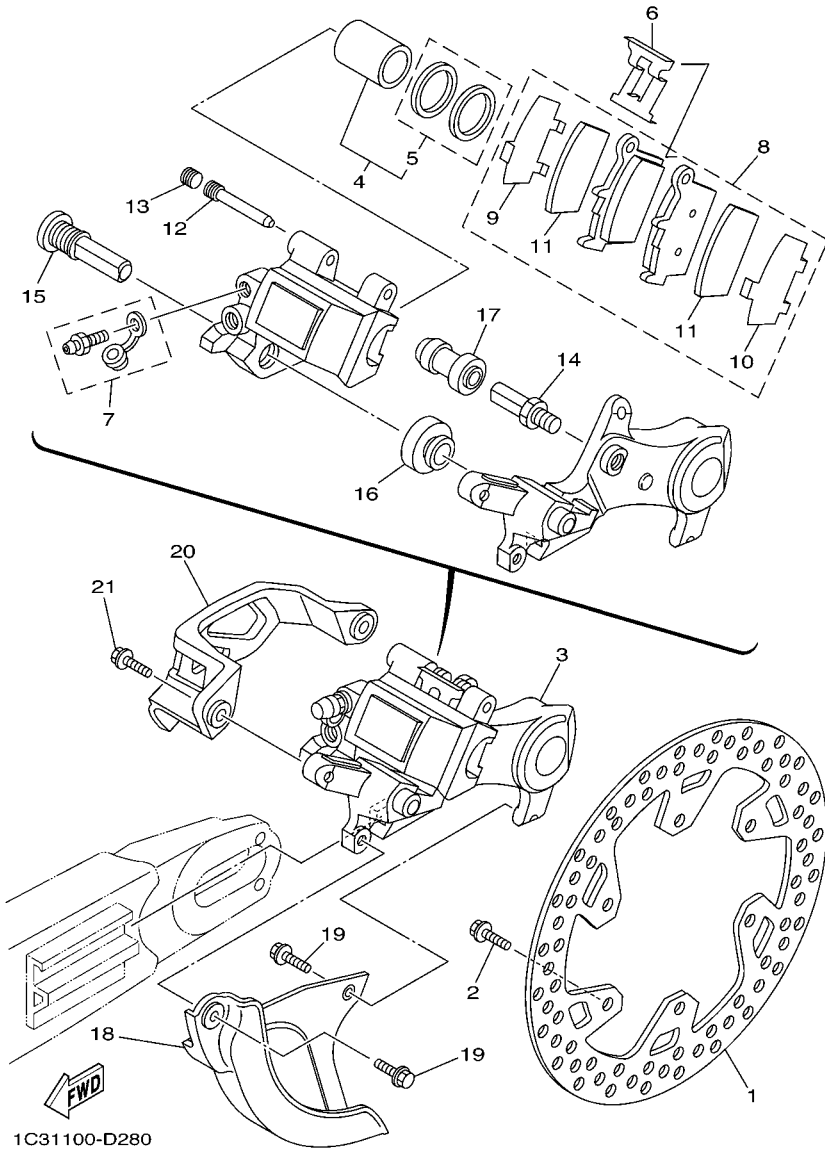

REF. NO.	PART NO.	DESCRIPTION	1C31	1C32	1C33	1C34	REMARKS
1	5NY-2582W-00	DISK, REAR BRAKE 2	1	1	1	1	
2	90109-065G4	BOLT	6	6	6	6	
3	1C3-2580W-00	CALIPER ASSY, REAR 2	1	1	1	1	
4	5UN-W0057-50	.PISTON ASSY, CALIPER	1	1	1	1	
5	5UN-W0047-50	..CALIPER SEAL KIT	1	1	1	1	
6	5DH-25919-50	..SUPPORT, PAD	1	1	1	1	
7	1UY-W0048-50	.BLEED SCREW KIT	1	1	1	1	
8	1C3-W0046-00	.BRAKE PAD KIT 2	1	1	1	1	
9	5UN-25828-60	..SHIM, CALIPER	1	1	1	1	
10	5UN-25827-60	..SHIM, CALIPER	1	1	1	1	
11	5UN-22898-60	..INSULATOR, HEAT	2	2	2	2	
12	8CR-25924-00	.PIN, PAD	1	1	1	1	
13	5DH-25916-00	.PLUG	1	1	1	1	
14	5DH-25914-00	.PIN, SLIDE	1	1	1	1	
15	3JD-25917-00	.BOOT, CALIPER	1	1	1	1	
16	5UN-25914-00	.PIN, SLIDE	1	1	1	1	
17	1UY-25937-51	.BOOT 2	1	1	1	1	
18	5DH-25718-01	PROTECTOR, DISK BRAKE	1	1	1	1	
19	95027-06012	BOLT, FLANGE	2	2	2	2	
20	5TA-27491-00	PROTECTOR	1	1	1	1	
21	95027-06016	BOLT, FLANGE	2	2	2	2	

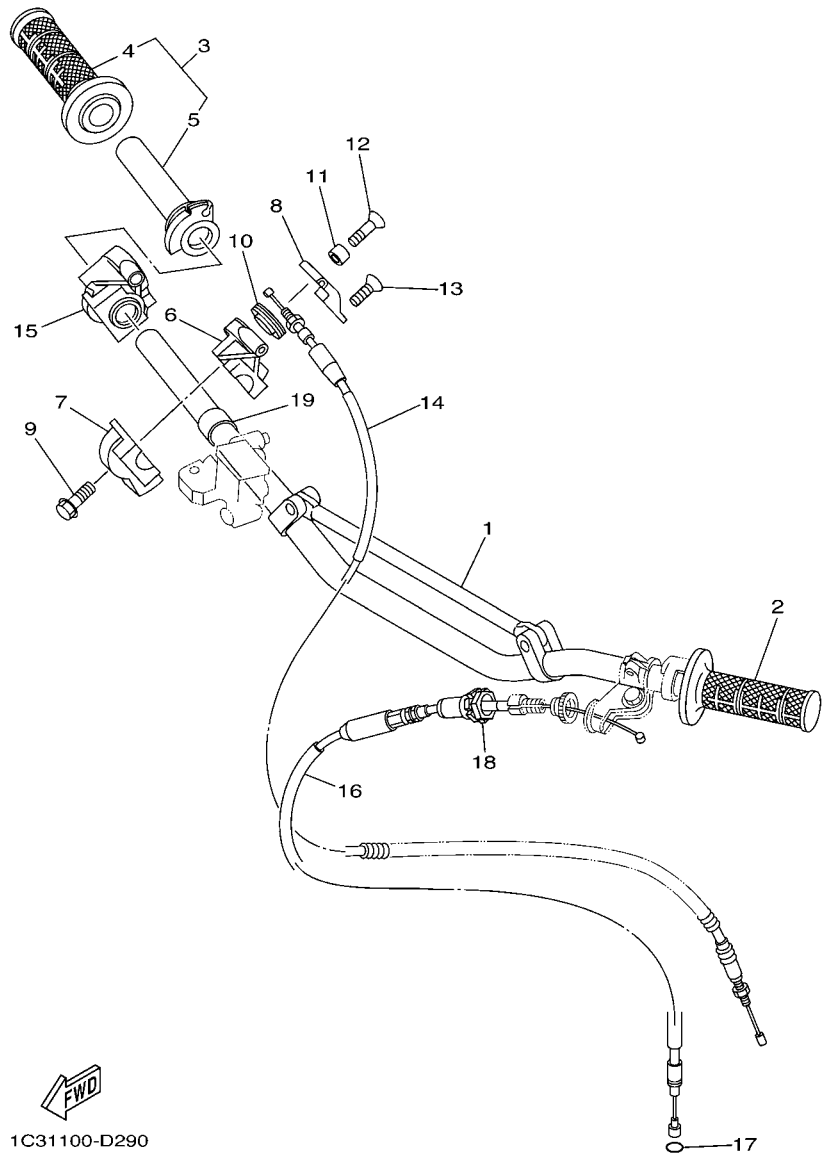

1C31100-D290

FIG. 29 STEERING HANDLE & CABLE

REF. NO.	PART NO.	DESCRIPTION	1C31	1C32	1C33	1C34	REMARKS
1	1C3-26111-00	HANDLEBAR	1	1	1	1	
2	4GY-26241-00	GRIP	1	1	1	1	
3	4XM-26240-00	GRIP ASSY	1	1	1	1	
4	4GY-26242-00	.GRIP (RIGHT)	1	1	1	1	
5	4XM-26243-00	.TUBE, THROTTLE GUIDE	1	1	1	1	
6	4SS-26281-00	CAP, GRIP UPPER	1	1	1	1	
7	4SS-26282-10	CAP, GRIP LOWER	1	1	1	1	
8	4SS-2628H-00	CAP, WIRE	1	1	1	1	
9	95027-06025	BOLT, FLANGE	2	2	2	2	
10	5NY-26273-00	ROTOR	1	1	1	1	
11	4SS-26259-00	COLLAR	1	1	1	1	
12	4SS-26256-00	SCREW, GRIP END	1	1	1	1	
13	4SS-2632G-00	SCREW	1	1	1	1	
14	1C3-26311-00	CABLE, THROTTLE 1	1	1	1	1	
15	4SS-26287-01	COVER, CAP GRIP	1	1	1	1	
16	1C3-26335-00	CABLE, CLUTCH	1	1	1	1	
17	93210-06001	O-RING	1	1	1	1	
18	5HD-26342-00	BOOT, CABLE	1	1	1	1	
19	90387-227H7	COLLAR	1	1	1	1	

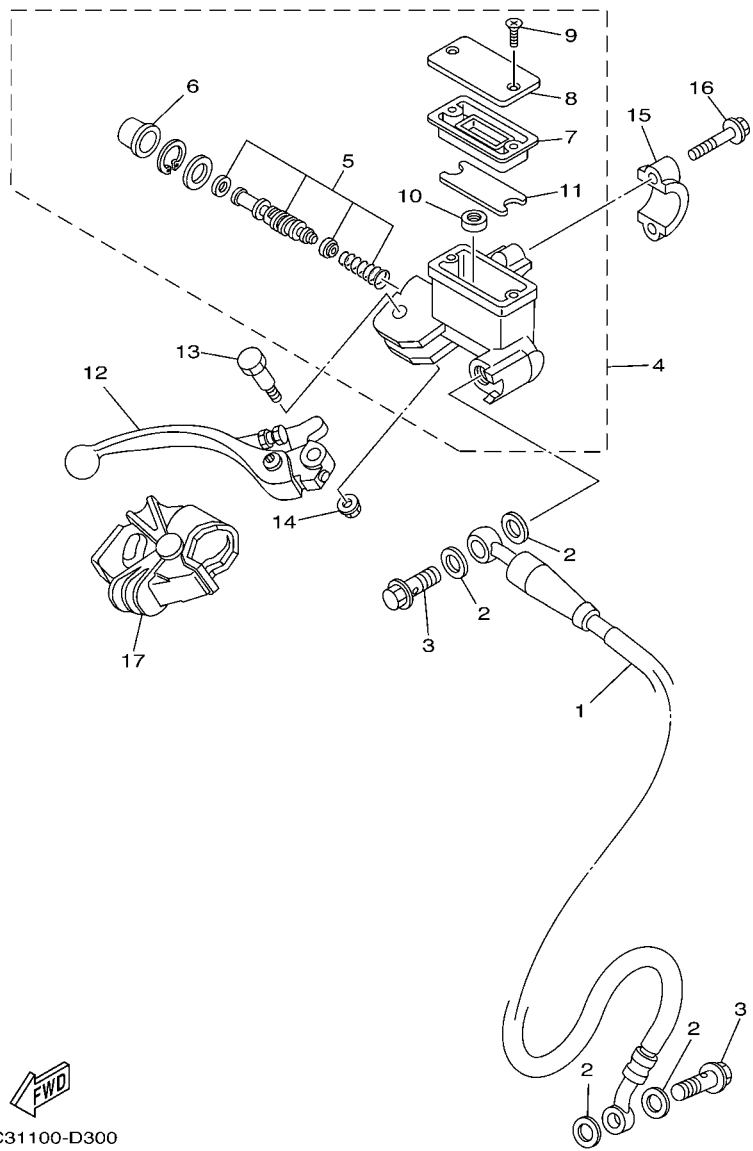



1C31100-D300

FIG. 30 FRONT MASTER CYLINDER

REF. NO.	PART NO.	DESCRIPTION	1C31	1C32	1C33	1C34	REMARKS
1	1C3-25872-00	HOSE, BRAKE 1	1	1	1	1	
2	90201-10118	WASHER, PLATE	4	4	4	4	
3	90401-10172	BOLT, UNION	2	2	2	2	
4	5XE-W2587-00	MASTER CYLINDER SUB ASSY	1	1	1	1	
5	5NY-W0041-00	.CYLINDER KIT, MASTER	1	1	1	1	
6	5NY-25868-00	.BOOT, MASTER CYLINDER	1	1	1	1	
7	5XE-25854-00	.DIAPHRAGM, RESERVOIR	1	1	1	1	
8	5MV-25852-01	.CAP, RESERVOIR	1	1	1	1	
9	98706-04012	.SCREW, FLAT HEAD	2	2	2	2	
10	5CG-25715-00	.SEPARATOR ASSY	1	1	1	1	
11	5XE-25853-00	.FLOAT, RESERVOIR	1	1	1	1	
12	5MV-83922-00	LEVER 2	1	1	1	1	
13	5MV-2589F-00	BOLT, LEVER	1	1	1	1	
14	95701-06500	NUT, FLANGE	1	1	1	1	
15	5MV-25867-00	BRACKET, MASTER CYLINDER	1	1	1	1	
16	5MV-25833-00	BOLT, FITTING	2	2	2	2	
17	5NY-26372-00	COVER, HANDLE LEVER 1	1	1	1	1	

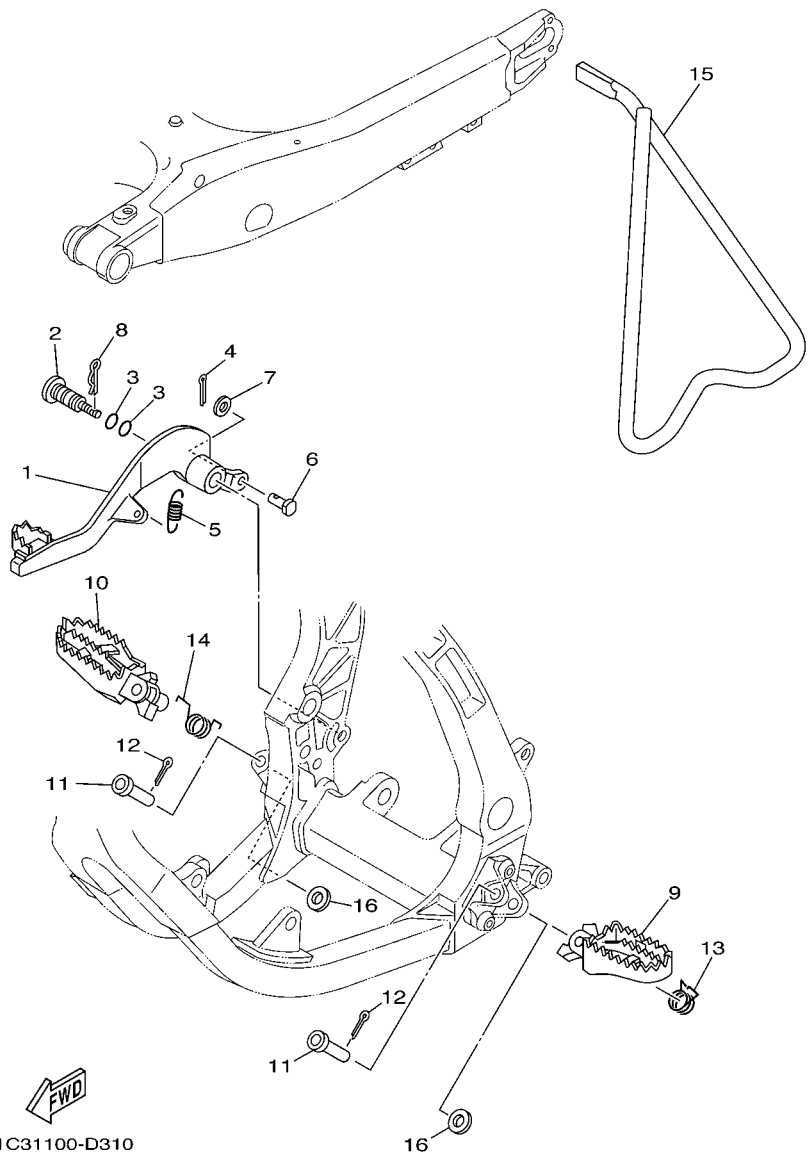
FIG. 31 STAND & FOOTREST



REF. NO.	PART NO.	DESCRIPTION	1C31	1C32	1C33	1C34	REMARKS
1	1C3-27200-00	PEDAL, BRAKE	1	1	1	1	
2	1C3-27217-00	BOLT	1	1	1	1	
3	93210-11073	O-RING	2	2	2	2	
4	91401-20012	PIN, COTTER	1	1	1	1	
5	90506-16500	SPRING, TENSION	1	1	1	1	
6	90240-08120	PIN, CLEVIS	1	1	1	1	
7	90201-08089	WASHER, PLATE	1	1	1	1	
8	90468-16099	CLIP	1	1	1	1	
9	5XE-27411-01	FOOTREST 1	1	1	1	1	
10	5XE-27421-01	FOOTREST 2	1	1	1	1	
11	90240-10142	PIN, CLEVIS	2	2	2	2	
12	91401-25015	PIN, COTTER	2	2	2	2	
13	90508-282B8	SPRING, TORSION	1	1	1	1	
14	90508-282B9	SPRING, TORSION	1	1	1	1	
15	1C3-27311-00	STAND, SIDE	1	1	1	1	
16	90201-10119	WASHER, PLATE	2	2	2	2	

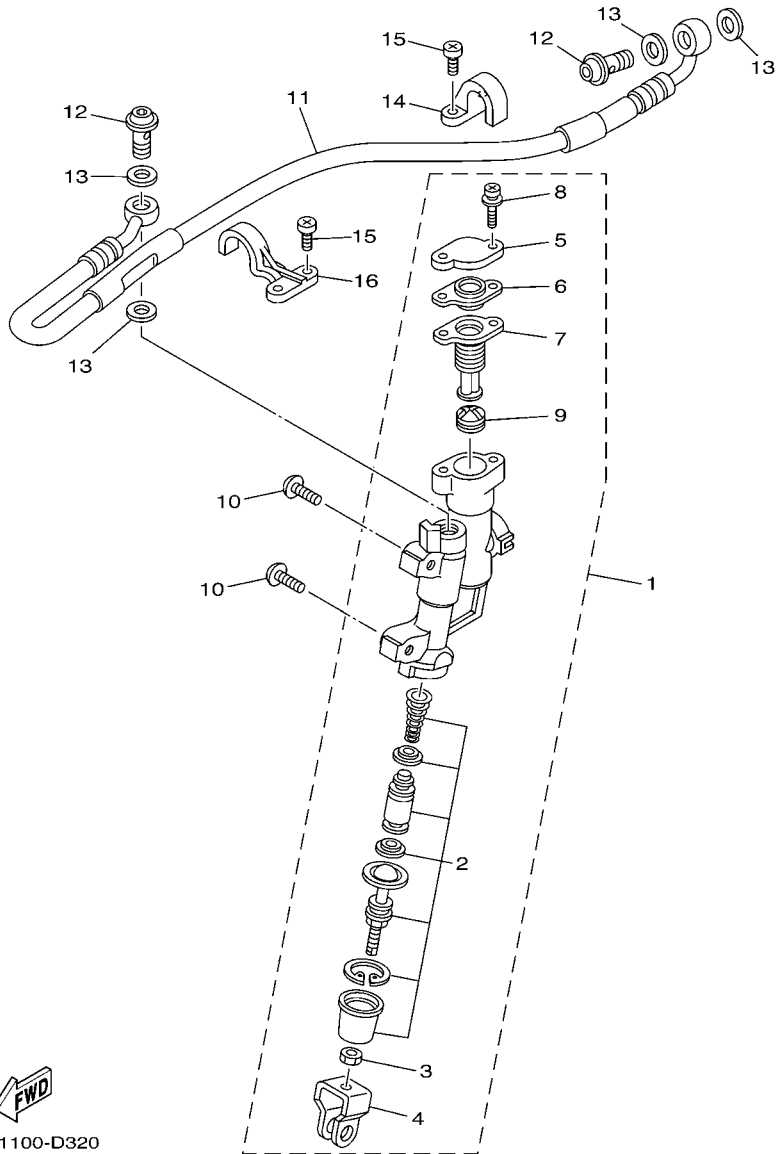

1C31100-D320

FIG. 32 REAR MASTER CYLINDER

REF. NO.	PART NO.	DESCRIPTION	1C31	1C32	1C33	1C34	REMARKS
1	1C3-2583V-00	RR. MASTER CYLINDER ASSY.	1	1	1	1	
2	5UN-W0042-50	.CYLINDER KIT, MASTER	1	1	1	1	
3	5UN-27218-00	.NUT	1	1	1	1	
4	5UN-27222-00	.JOINT	1	1	1	1	
5	5UN-25852-50	.CAP, RESERVOIR	1	1	1	1	
6	5UN-2585B-00	.PLATE, DIAPHRAGM	1	1	1	1	
7	5UN-25854-00	.DIAPHRAGM, RESERVOIR	1	1	1	1	
8	5UN-27217-00	.BOLT	2	2	2	2	
9	5CG-25715-00	.SEPARATOR ASSY	1	1	1	1	
10	90111-06029	BOLT	2	2	2	2	
11	1C3-25873-00	HOSE, BRAKE 2	1	1	1	1	
12	90401-10172	BOLT, UNION	2	2	2	2	
13	90201-10118	WASHER, PLATE	4	4	4	4	
14	2VM-25876-00	HOLDER, BRAKE HOSE 2	1	1	1	1	
15	98507-05010	SCREW, PAN HEAD	4	4	4	4	
16	1C3-25876-00	HOLDER, BRAKE HOSE 2	1	1	1	1	

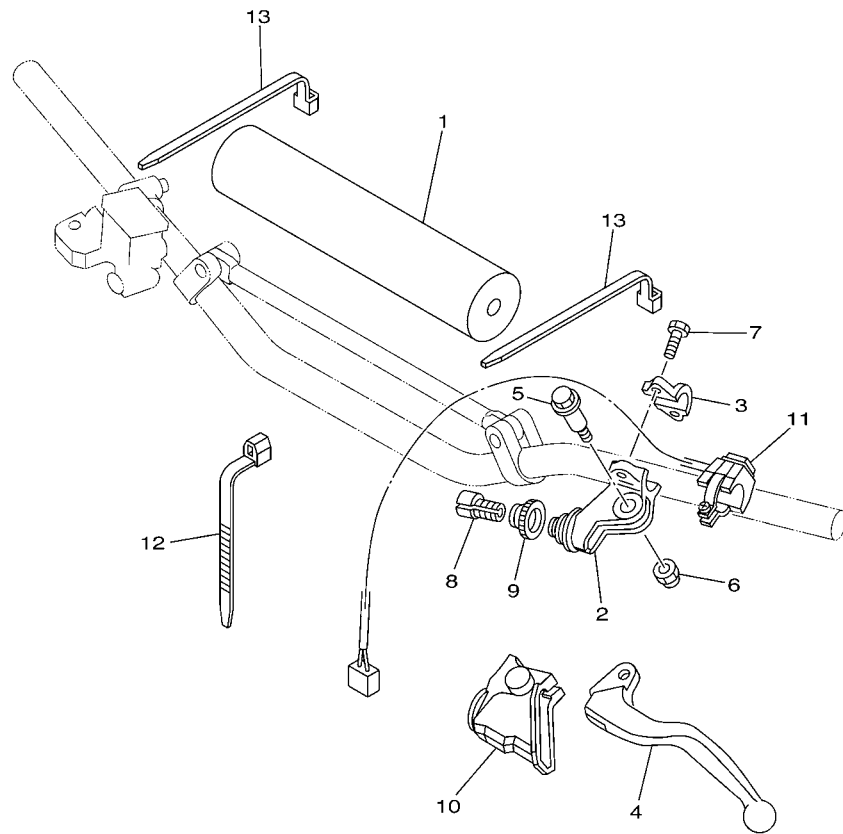

FIG. 34 HANDLE SWITCH & LEVER

REF. NO.	PART NO.	DESCRIPTION	1C31	1C32	1C33	1C34	REMARKS
1	1C3-26124-00	PROTECTOR, HANDLEBAR	1	1	1	1	
2	5XE-82911-00	HOLDER, LEVER 1	1	1	1	1	
3	5TG-82913-00	HOLDER, LEVER LOWER 1	1	1	1	1	
4	5MV-83912-00	LEVER 1	1	1	1	1	
5	90109-06034	BOLT	1	1	1	1	
6	5LP-84126-10	NUT, LENS FITTING	1	1	1	1	
7	90101-05033	BOLT	2	2	2	2	
8	5HD-26337-00	BOLT, ADJUSTING	1	1	1	1	
9	5HD-83951-00	BOLT, CABLE ADJUSTING	1	1	1	1	
10	5HD-26372-00	COVER, HANDLE LEVER 1	1	1	1	1	
11	1C3-83976-00	SWITCH, HANDLE 1	1	1	1	1	
12	90464-13077	CLAMP	3	3	3	3	
13	90464-15195	CLAMP	2	2	2	2	



1C31100-D340

FIG. 36 ALTERNATE FOR CHASSIS

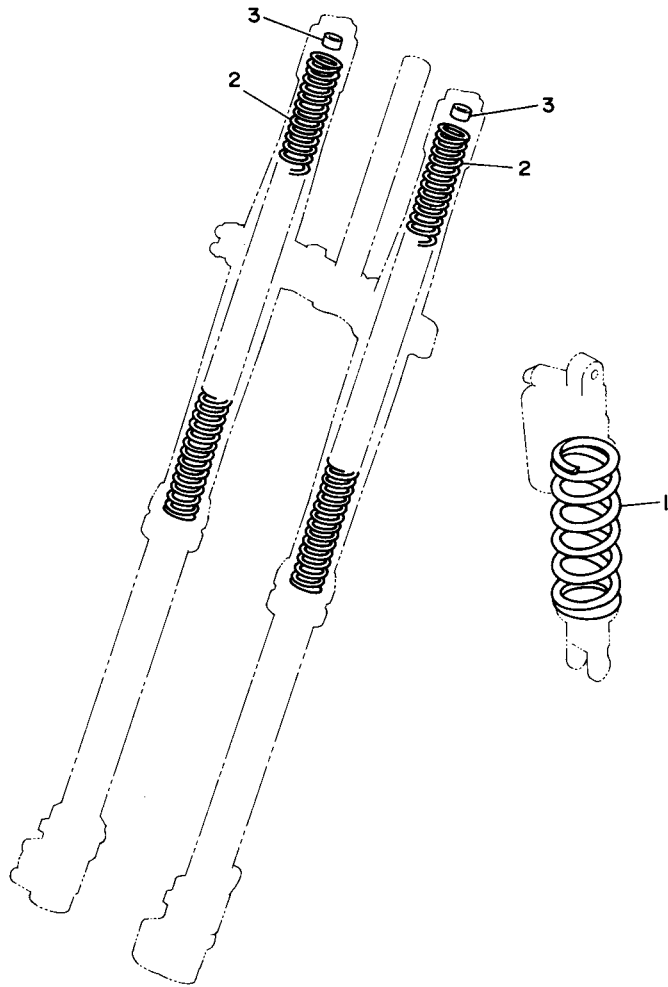

FWD
3XJ1100-1360

REF. NO.	PART NO.	DESCRIPTION	1C31	1C32	1C33	1C34	REMARKS
1	5UN-22212-00	SPRING (K=42N/MM)	1	1	1	1	AP
	5UN-22212-10	SPRING (K=44N/MM)	1	1	1	1	AP
	5UN-22212-30	SPRING (K=48N/MM)	1	1	1	1	AP
	5UN-22212-40	SPRING (K=50N/MM)	1	1	1	1	AP
	5UN-22212-50	SPRING (K=52N/MM)	1	1	1	1	AP
	5UN-22212-60	SPRING (K=54N/MM)	1	1	1	1	AP
	5UN-22212-70	SPRING (K=56N/MM)	1	1	1	1	AP
	5UN-22212-A0	SPRING (K=APPROX.44N/MM)	1	1	1	1	AP
	5UN-22212-B0	SPRING (K=APPROX.46N/MM)	1	1	1	1	AP
	5UN-22212-C0	SPRING (K=APPROX.48N/MM)	1	1	1	1	AP
2	5UN-22212-D0	SPRING (K=APPROX.50N/MM)	1	1	1	1	AP
	5UN-22212-E0	SPRING (K=APPROX.52N/MM)	1	1	1	1	AP
	5UN-22212-F0	SPRING (K=APPROX.54N/MM)	1	1	1	1	AP
	5UN-22212-G0	SPRING (K=APPROX.56N/MM)	1	1	1	1	AP
	1C3-23141-00	SPRING (K=3.9N/MM)	2	2	2	2	AP
	1C3-23141-10	SPRING (K=4.0N/MM)	2	2	2	2	AP
	1C3-23141-20	SPRING (K=4.1N/MM)	2	2	2	2	AP
	1C3-23141-30	SPRING (K=4.2N/MM)	2	2	2	2	AP
	1C3-23141-40	SPRING (K=4.3N/MM)	2	2	2	2	AP
	1C3-23141-50	SPRING (K=4.4N/MM)	2	2	2	2	AP
3	1C3-23141-60	SPRING (K=4.5N/MM)	2	2	2	2	AP
	1C3-23141-70	SPRING (K=4.6N/MM)	2	2	2	2	AP
	1C3-23141-80	SPRING (K=4.7N/MM)	2	2	2	2	AP
	1C3-23364-00	COLLAR 2	1	1	1	1	UN

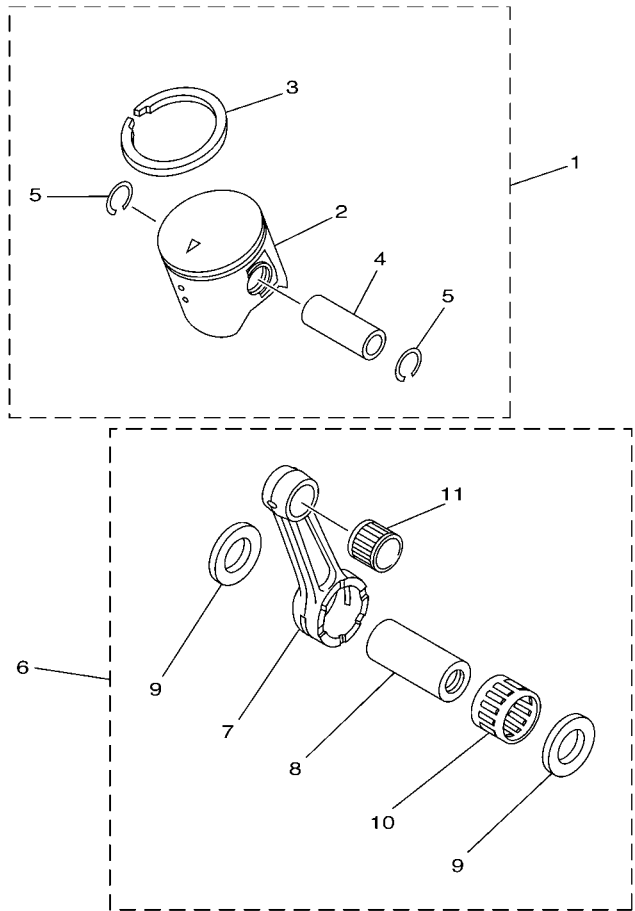

5NY1100-A370

FIG. 37 OPTIONAL PARTS 1

REF. NO.	PART NO.	DESCRIPTION	1C31	1C32	1C33	1C34	REMARKS
1	1C3-11630-00	PISTON ASSY (STD)	1	1	1	1	
2	1C3-11631-00-B0	.PISTON (STD)	1	1	1	1	ORANGE
3	5NY-11611-00	.RING, PISTON	1	1	1	1	
4	1C3-11633-00	.PIN, PISTON	1	1	1	1	
5	93450-16068	.CIRCLIP	2	2	2	2	
6	1C3-11650-00	CONNECTING ROD ASSY	1	1	1	1	
7	1C3-11651-00	.ROD, CONNECTING	1	1	1	1	
8	3JD-11681-10	.PIN, CRANK 1	1	1	1	1	
9	90209-22326	.WASHER	2	2	2	2	
10	93310-52238	.BEARING	1	1	1	1	
11	93310-21510	.BEARING	1	1	1	1	

NUMERICAL INDEX

PART NO.	GRID NO.	PART NO.	GRID NO.	PART NO.	GRID NO.	PART NO.	GRID NO.	PART NO.	GRID NO.	PART NO.	GRID NO.
1C3-23141-40	E - 6	1C3-24183-00	D - 5	5MV-25852-01	D - 14	1C3-27200-00	D - 15	90105-08659	D - 9	90201-06071	C - 9
1C3-23141-50	E - 6	1C3-24184-00	D - 6	5UN-25852-50	E - 2	1C3-27217-00	D - 15	90105-10072	C - 7	90201-062A8	C - 9
1C3-23141-60	E - 6	5NY-24186-00	D - 5	5XE-25853-00	D - 14	5UN-27217-00	E - 2	90105-10080	C - 7	90201-06557	B - 12
1C3-23141-70	E - 6	1C3-24240-00	D - 5	5UN-25854-00	E - 2	5UN-27218-00	E - 2	90109-06034	E - 4		C - 9
1C3-23141-80	E - 6	3XJ-24380-00	D - 5	5XE-25854-00	D - 14	5UN-27222-00	E - 2	90109-063F8	C - 5	90201-06571	B - 7
1C3-23141-L0	D - 2	3JD-24500-02	D - 5	5UN-2585B-00	E - 2	1C3-27311-00	D - 15	90109-065G4	D - 12	90201-08039	C - 7
1C3-23141-M0	D - 2	4X8-24512-00	D - 5	5MV-25867-00	D - 14	5XE-27411-01	D - 15	90109-067F4	B - 8	90201-08089	D - 15
5XE-23144-L0	D - 2	5MV-24514-00	B - 11	5NY-25868-00	D - 14	5XE-27421-01	D - 15	90109-081G1	D - 10	90201-080H1	C - 2
1C3-23145-L0	D - 2	3AJ-24534-01	D - 5	1C3-25872-00	D - 14	5TA-27491-00	D - 12	90111-06029	E - 2	90201-080L8	B - 2
5XE-23146-L0	D - 2	5NY-24610-00	D - 5	1C3-25873-00	E - 2	5ET-28166-00	C - 8	90116-08318	B - 2	90201-08326	D - 10
1C3-23147-L0	D - 2	5XE-2470F-00	D - 7	1C3-25875-00	D - 9	1C3-8231U-00	E - 5	90116-08388	B - 2	90201-08512	B - 6
1C3-2314F-L0	D - 2	5NY-24728-00	D - 7	1C3-25876-00	E - 2	1C3-82320-00	E - 5	90116-08394	B - 2	90201-086P8	C - 7
1C3-2314H-00	D - 4	5XE-24770-00	D - 7	2VM-25876-00	E - 2	1C3-82509-00	E - 5	90119-06096	C - 9	90201-08730	C - 7
1C3-2314J-00	D - 4	5NY-25104-00	D - 8	5MV-2589F-00	D - 14	5XE-82911-00	E - 4	90119-06225	C - 9	90201-10118	D - 14
5XE-23153-L0	D - 2	5NY-25111-00	D - 8	5DH-25914-00	D - 12	5TG-82913-00	E - 4		C - 15		E - 2
2HH-23158-L0	D - 2	5NY-25117-00	D - 8	5UN-25914-00	D - 12	5MV-83912-00	E - 4	90119-08238	C - 10	90201-10119	D - 15
1C3-2316A-L0	D - 2	1C3-25181-00	D - 8	3SP-25914-51	D - 9	5MV-83922-00	D - 14	90122-06035	B - 8	90201-12020	C - 6
1C3-2316A-M0	D - 2	5NY-25183-00	D - 8	5DH-25916-00	D - 9	5HD-83951-00	E - 4	90149-06011	D - 5	90201-127E1	E - 3
1C3-2316E-L0	D - 2	5NY-25186-00	D - 8		D - 12	1C3-83976-00	E - 4		E - 3	90201-14740	C - 12
1C3-23170-L0	D - 2	5HD-25304-00	D - 10	3JD-25917-00	D - 9	5LP-84126-10	E - 4	90149-06326	C - 3	90201-150U6	B - 4
1C3-23170-M0	D - 2	5ET-25311-00	D - 10		D - 12	1C3-85540-00	E - 5	90149-06327	D - 9	90201-160F6	C - 11
5XE-23171-L0	D - 2	5ET-25317-00	D - 10	5DH-25919-00	D - 9	1C3-85546-00	E - 5	90151-04001	C - 11	90201-171G4	B - 15
5DH-23183-00	C - 13	4XM-25364-00	D - 10	5DH-25919-50	D - 12	1C3-85550-00	E - 3	90152-06010	B - 15	90201-175F6	B - 15
509-23184-L0	C - 13	5ET-25367-00	D - 11	8CR-25924-00	D - 12	1C3-85560-00	E - 3	90159-06016	C - 2	90201-203U1	D - 11
5UX-23188-00	D - 2	1C3-25381-00	D - 11	3SP-25926-51	D - 9	5NY-W0041-00	D - 14	90159-06078	C - 10	90201-20611	C - 2
43F-23188-10	D - 2	5UN-25383-00	D - 11	5DH-25933-00	D - 9	5UN-W0042-50	E - 2	90170-16326	C - 2	90201-21013	C - 11
1C3-23188-L0	D - 2	1C3-25388-00	D - 11	1UY-25937-51	D - 9	5MV-W0045-01	D - 9	90176-08026	B - 2	90201-22555	C - 3
1C3-23188-M0	D - 2	1C3-25389-00	D - 11		D - 12	1C3-W0046-00	D - 12	90179-06568	C - 11	90201-247L2	C - 15
5TJ-2319U-00	C - 15	4XM-25394-00	D - 10	1C3-26111-00	D - 13	3JD-W0047-00	D - 9	90179-08299	B - 2	90201-286K9	C - 15
1C3-23340-L0	D - 4	5SF-25394-00	D - 8	1C3-26124-00	E - 4	5UN-W0047-50	D - 12		D - 11	90202-05193	D - 5
5NY-23346-L0	D - 4	1C3-25447-00	D - 10	4XM-26240-00	D - 13	1UY-W0048-50	D - 9	90179-08674	C - 7	90209-06096	B - 8
3SP-23356-L0	D - 4	1C3-25448-00	D - 10	4GY-26241-00	D - 13		D - 12	90179-10658	C - 7	90209-16008	C - 11
5TA-23357-00	C - 15	1C3-25449-00	D - 10	4GY-26242-00	D - 13	5UN-W0057-00	D - 9	90179-12248	E - 3	90209-18135	C - 3
1C3-23364-00	E - 6	1C3-25450-00	D - 10	4XM-26243-00	D - 13	5UN-W0057-50	D - 12	90179-16002	D - 8	90209-20008	C - 3
5XE-23389-00	D - 4	1C3-25451-00	D - 10	4SS-26256-00	D - 13	5XE-W2587-00	D - 14	90179-18001	C - 4	90209-22326	B - 5
4EW-23416-00	C - 15	1C3-25452-00	D - 10	4SS-26259-00	D - 13	90101-05033	E - 4	90179-28003	C - 15		E - 7
5XE-23435-20	C - 15	5CG-25715-00	D - 14	5NY-26273-00	D - 13	90101-06034	C - 6	90183-06023	B - 8	90209-23012	C - 3
5XE-23441-00	C - 15		E - 2	4SS-26281-00	D - 13	90101-08777	D - 11	90185-08055	C - 7	90215-16289	C - 2
1C3-23466-00	D - 9	5DH-25718-01	D - 12	4SS-26282-10	D - 13	90105-06045	C - 9	90185-08169	D - 10	90215-20003	C - 4
1C3-23467-00	D - 9	1C3-2580T-00	D - 9	4SS-26287-01	D - 13	90105-06046	C - 9	90185-10060	C - 14	90240-08120	D - 15
1C3-23485-10	C - 15	1C3-2580W-00	D - 12	4SS-2628H-00	D - 13	90105-06055	C - 10	90185-14007	C - 12	90240-10142	D - 15
1C3-24110-00	D - 5	5MV-2581T-00	D - 9	1C3-26311-00	D - 13	90105-06060	E - 5	90185-16127	C - 11	90267-32070	B - 8
4EW-2412F-00	D - 5	5UN-25827-60	D - 12	4SS-2632G-00	D - 13	90105-06553	C - 5	90185-20168	D - 11	90280-03017	B - 5
5XE-24144-00	D - 5	5UN-25828-60	D - 12	1C3-26335-00	D - 13	90105-06556	B - 13	90201-03313	B - 8	90387-06009	C - 9
3SP-24173-00	D - 5	5NY-2582W-00	D - 12	5HD-26337-00	E - 4	90105-08057	C - 7	90201-057H5	B - 4	90387-06039	B - 12
5XE-24176-00	D - 5	5MV-25833-00	D - 14	5HD-26342-00	D - 13	90105-08059	C - 7	90201-06060	B - 12	90387-06065	B - 7
1C3-24181-00	D - 5	1C3-2583V-00	E - 2	5HD-26372-00	E - 4	90105-08071	C - 2		B - 15	90387-06090	C - 9
1C3-24182-00	D - 5	5DH-25849-00	D - 9	5NY-26372-00	D - 14	90105-08120	C - 7	90201-06071	B - 12	90387-063G3	B - 12

NUMERICAL INDEX

PART NO.	GRID NO.	PART NO.	GRID NO.	PART NO.	GRID NO.	PART NO.	GRID NO.	PART NO.	GRID NO.	PART NO.	GRID NO.
90387-08027	C - 7	90506-20012	B - 12	93210-19123	B - 14	94110-19009	D - 10	97007-05012	B - 4		
90387-08032	B - 6	90508-16134	B - 3	93210-63442	B - 2	94110-19011	D - 10	97007-05016	B - 3		
90387-085E1	B - 4	90508-261B7	C - 5	93210-90785	B - 2	94110-1913B	D - 10	97027-06012	B - 15		
90387-086N4	C - 7	90508-26450	B - 15	93300-60801	B - 4	94209-21229	D - 8	97307-06012	D - 7		
90387-08785	B - 3	90508-282B8	D - 15		B - 6	94210-19222	D - 10	97707-60016	C - 9		
90387-107T9	B - 4	90508-282B9	D - 15	93300-60804	C - 7	94210-19224	D - 10	98502-05014	B - 11		
90387-14005	C - 12	90508-29020	C - 6	93300-60814	B - 6	94227-21101	D - 8	98507-03006	B - 8		
90387-152F2	B - 4	90560-12280	C - 6	93306-00326	C - 3	94309-21161	D - 8	98507-03008	D - 5		
90387-16010	C - 11	91317-04006	B - 4	93306-00442	C - 3	94316-19156	D - 10	98507-04008	B - 9		
90387-172K2	C - 2	91317-04010	B - 2	93306-07202	D - 10	94321-19135	D - 10	98507-04014	B - 9		
90387-18008	C - 11	91317-05012	B - 2	93306-20351	C - 3	94330-21084	D - 8	98507-05010	E - 2		
90387-18009	C - 11	91317-06045	B - 13	93306-20447	C - 3	94416-21003	D - 8	98507-05012	B - 4		
90387-22004	C - 4	91317-06055	B - 13	93306-27205	D - 10	94418-19601	D - 10	98507-06030	B - 14		
90387-227H7	D - 13	91317-06065	B - 13	93306-37204	B - 5	94681-68001	D - 11	98706-04012	D - 14		
90401-10172	D - 14	91317-06075	B - 13	93306-90403	D - 8	94702-00324	B - 2	98707-06025	D - 5		
	E - 2	91401-20012	D - 15	93306-90408	C - 5	94709-00324	B - 2	98907-05016	B - 2		
90430-06014	B - 6	91401-25015	D - 15	93310-21510	B - 5	95027-06010	B - 6	98907-06025	D - 5		
	B - 14	91A20-05065	B - 7		E - 7		C - 11	99009-17400	B - 15		
90430-10188	B - 13	92017-06010	B - 12	93310-22539	C - 2		D - 9	99009-45500	D - 10		
90445-08605	B - 13	92017-06012	B - 14	93310-52238	B - 5	95027-06012	B - 12	99530-08016	B - 14		
90445-09025	D - 5	92907-03100	B - 8		E - 7		D - 12	99530-10116	B - 13		
90445-09220	D - 5	92907-05600	B - 3	93315-11040	C - 2	95027-06014	B - 12	99590-10114	B - 2		
90445-111J0	D - 5	92907-06100	D - 7	93315-32165	C - 11	95027-06016	D - 5	99590-17016	B - 13		
90450-22017	B - 7	92907-06600	B - 14	93315-32166	C - 11		D - 12	9Y581-92111	D - 11		
90450-25037	B - 7	92907-10200	C - 7	93317-22262	C - 11	95027-06020	B - 8				
90450-28014	B - 7		C - 14	93332-00068	C - 15		C - 6				
90450-54004	B - 8	93102-08004	B - 6	93332-00081	D - 4		D - 4				
90450-70001	B - 8	93102-08307	B - 6	93340-21008	C - 2	95027-06025	B - 6				
90461-10136	B - 13	93102-10008	C - 2	93340-21505	B - 4		B - 7				
90464-13077	E - 4	93102-12224	C - 6	93342-22217	C - 11		B - 12				
90464-15195	E - 4	93102-17263	B - 15	93410-22039	C - 3		B - 14				
90465-13275	D - 5	93102-20485	B - 5	93410-26067	C - 3		D - 13				
	E - 5	93102-22419	B - 5	93440-07182	B - 6	95027-06030	B - 14				
90467-09006	B - 7	93102-26468	D - 8		C - 2	95027-06040	B - 14				
90467-10008	D - 5	93102-28012	C - 4	93450-16068	B - 5	95027-06050	B - 14				
90467-13062	B - 2	93104-08040	B - 2		E - 7		C - 11				
90468-16099	D - 15		B - 4	93507-16020	B - 4	95027-06065	B - 6				
90468-26048	B - 15	93104-12003	C - 6	93507-32009	B - 15		B - 14				
90480-08608	D - 11	93106-22019	C - 11	93511-32027	C - 2	95027-08035	C - 15				
90480-15528	B - 7	93106-30044	D - 10	93603-12007	B - 6	95027-08040	C - 7				
90480-16404	B - 12	93106-30045	D - 10	93603-14240	B - 4		C - 15				
90480-16561	B - 12	93109-21001	C - 12	93604-10011	B - 6	95027-08055	C - 7				
90480-18549	D - 5	93109-25001	C - 11		B - 14	95027-10016	B - 13				
90501-052G5	C - 6	93109-28043	C - 11	93608-33002	C - 6	95607-10200	C - 13				
90501-12081	B - 15	93210-06001	D - 13	9383B-13218	C - 4	95701-06500	D - 14				
90501-23598	C - 2	93210-11073	D - 15	94108-21012	D - 8	95707-06500	D - 9				
90501-30001	B - 4	93210-15171	B - 15	94108-21015	D - 8	95827-06010	B - 7				
90506-16500	D - 15	93210-16314	B - 13	94108-2112Y	D - 8	95827-06016	C - 10				