



PARTS CATALOGUE

YZ250 (1SS6) EUROPE

YZ250 (1SS7) JAPAN

YZ250D2 (1SS8) AUSTRALIA, NEW ZEALAND

YZ250 (1SS8) SOUTH AFRICA

YZ250/YZ250D2
PARTS CATALOGUE
©2012 by Yamaha Motor Co., Ltd.
1st edition, August 2012
All rights reserved.
Any reprinting or unauthorized use
without the written permission of
Yamaha Motor Co., Ltd.
is expressly prohibited.
Printed in Japan.

FOREWORD

This Parts Catalogue is related to the parts for the model(s) on the cover page. When you are ordering replacement parts, please refer to this Parts Catalogue and quote both part numbers and part names correctly.

1. Modifications or additions which have been made after the issue of the Parts Catalogue will be announced in the Parts News.

It is advisable that you make the necessary corrections to the Parts Catalogue according to the Parts News.

2. Abbreviations

The following abbreviations are used in this Parts Catalogue.

“UR” Use specified parts number.

“UN” Use as many as needed.

“AP” Alternate Parts

“LM” Locally Made (Parts need to be ordered locally)

“F#” Frame No. (Applicable machine No.)

“O/S” Over Size

3. The number of components for assembly

- Parts, which are to be supplied in an assembly, are listed with a dot (.) in front of the part name as shown below.
- The numeral appearing to the right of each component part indicates the quantity of parts for each assembly unit.

PART NO.	DESCRIPTION	Q'TY	REMARKS
2F5-83310-60	FRONT FLASHER LIGHT ASSY	2	
115-83311-60	.BULB (6V-18W)	1	

4. Applicable colours of graphics are represented in the “REMARKS” as shown below.

PART NO.	DESCRIPTION	Q'TY	REMARKS
2N4-24110-00-X5	FUEL TANK COMP.	2	MXR
3J1-24240-10	.GRAPHIC, FUEL TANK	1	FOR MXR

5. Note that the illustrations for reference in finding parts numbers are not to be used for assembling. When assembling, please use the applicable service manual.

6. The asterisk (*) before a reference number indicates modified items after the first edition.

FOREWORD

7. Applicable Serial No.

Engine Serial No.

Frame Serial No.

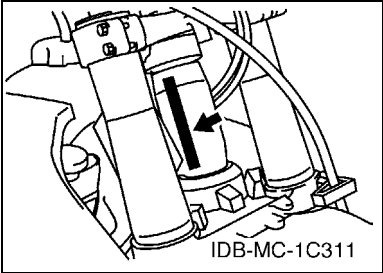
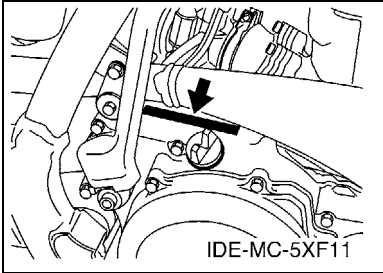

8. Applicable Colour Code (The (*) mark shows Model colour.)

Abbreviation	Colour Name	Colour Code
DPBSE(*)	DEEP PURPLISH BLUE SOLID E	0583

CONTENTS

ENGINE

CYLINDER HEAD	1
GOVERNOR	3
CRANKSHAFT & PISTON	4
WATER PUMP	5
RADIATOR & HOSE	6
INTAKE	7
CARBURETOR	8
EXHAUST	12
CRANKCASE	13
CRANKCASE COVER 1	14
STARTER	15
CLUTCH	16
TRANSMISSION	18
SHIFT CAM & FORK	20
SHIFT SHAFT	21

CHASSIS

FRAME	22
FENDER	24
SIDE COVER	25
REAR ARM	26
REAR SUSPENSION	28
STEERING	30
FRONT FORK	31
FUEL TANK	34
SEAT	36
FRONT WHEEL	37
FRONT BRAKE CALIPER	38
REAR WHEEL	39
REAR BRAKE CALIPER	41
STEERING HANDLE & CABLE	42
FRONT MASTER CYLINDER	43
STAND & FOOTREST	44
REAR MASTER CYLINDER	45
GENERATOR	46
HANDLE SWITCH & LEVER	47
ELECTRICAL 1	48
ALTERNATE FOR CHASSIS	49
OPTIONAL PARTS 1	50

INDEX

NUMERICAL INDEX	51
-----------------------	----

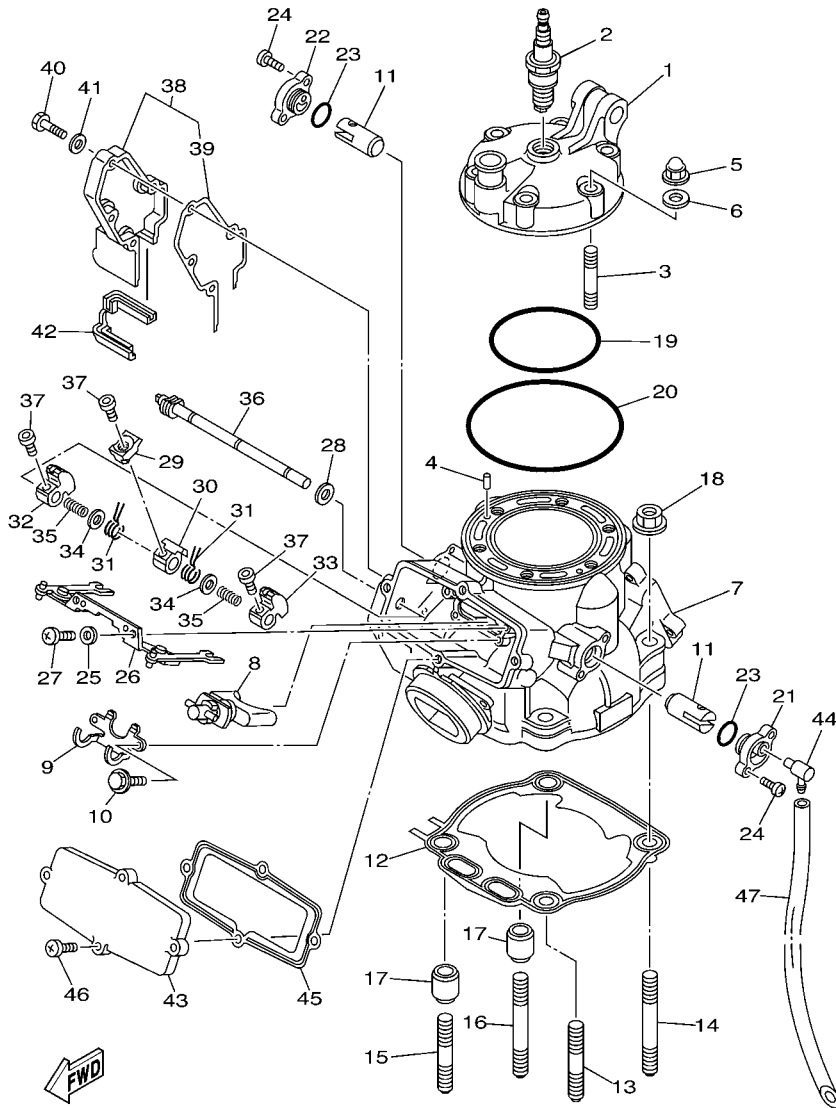

5NX1100-A010

FIG. 1 CYLINDER HEAD

REF. NO.	PART NO.	DESCRIPTION	1S86	1S87	1S88	REMARKS
1	5MW-11111-01	HEAD, CYLINDER 1	1	1	1	
2	94702-00326	PLUG, SPARK (NGK BR8EG)	1	1		
	94709-00326	PLUG, SPARK (NGK BR8EG)		1		
3	90116-08027	BOLT, STUD	6	6	6	
4	93604-08071	PIN, DOWEL	2	2	2	
5	90176-08005	NUT, CROWN	6	6	6	
6	90201-080L8	WASHER, PLATE	6	6	6	
7	5UP-11311-20	CYLINDER 1	1	1	1	
8	5XF-1131D-00	VALVE ASSY	1	1	1	
9	5CU-1131U-10	HOLDER 3	1	1	1	
10	90109-05001	BOLT	2	2	2	
11	5CU-1132A-00	VALVE 2	2	2	2	
12	5UP-11351-00	GASKET, CYLINDER	1	1	1	
13	90116-10034	BOLT, STUD	1	1	1	
14	95612-10660	BOLT, STUD	1	1	1	
15	90116-10034	BOLT, STUD	1	1	1	
16	95612-10660	BOLT, STUD	1	1	1	
17	99590-14016	PIN, DOWEL	2	2	2	
18	90179-10M35	NUT	4	4	4	
19	93210-74316	O-RING	1	1	1	
20	93211-02703	O-RING	1	1	1	
21	5CU-1131E-01	HOLDER 1	1	1	1	
22	5CU-1131P-00	HOLDER 4	1	1	1	
23	93210-15639	O-RING	2	2	2	
24	98502-05012	SCREW, PAN HEAD	4	4	4	
25	90201-05021	WASHER, PLATE	2	2	2	
26	5CU-11830-00	LINK ASSY	1	1	1	

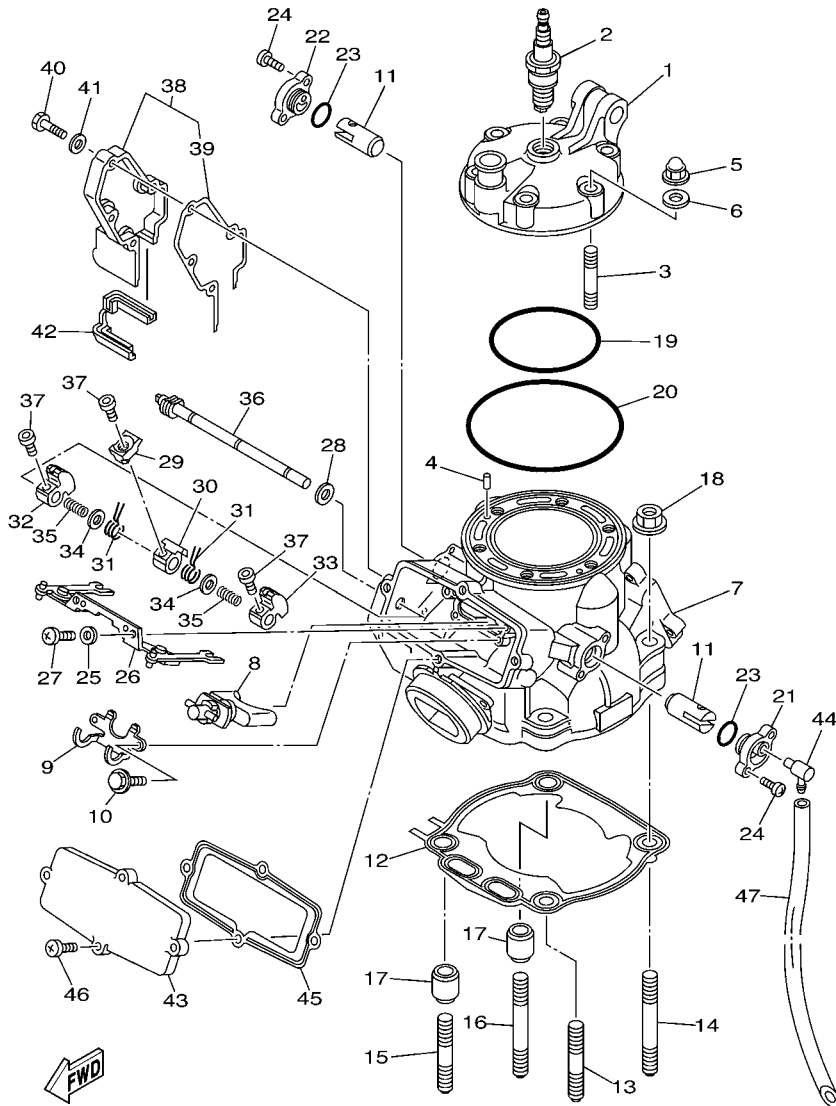

5NX1100-A010

FIG. 1 CYLINDER HEAD

REF. NO.	PART NO.	DESCRIPTION	1S86	1S87	1S88	REMARKS
27	98902-05012	SCREW, BIND	2	2	2	
28	93104-08040	OIL SEAL	1	1	1	
29	5NX-11395-00	HOLDER	1	1	1	
30	4SS-11832-00	LEVER, LINK	1	1	1	
31	90508-155B8	SPRING, TORSION	2	2	2	
32	5MW-1132E-00	PULLEY 1	1	1	1	
33	5MW-1132F-00	PULLEY 2	1	1	1	
34	90201-081G0	WASHER, PLATE	2	2	2	
35	90501-046L6	SPRING, COMPRESSION	2	2	2	
36	5CU-1131V-00	SHAFT 1	1	1	1	
37	91312-04008	BOLT	3	3	3	
38	5CU-11991-00	HOUSING 1	1	1	1	
39	5CU-11993-00	.GASKET	1	1	1	
40	97002-05020	BOLT	4	4	4	
41	92902-05600	WASHER, PLATE	4	4	4	
42	5CU-11995-00	SEAL, HOUSING	1	1	1	
43	5CU-1131M-10	COVER	1	1	1	
44	353-13115-01	CONNECTOR, SUCTION PIPE	1	1	1	
45	5CU-11354-00	GASKET	1	1	1	
46	98902-05016	SCREW, BIND	4	4	4	
47	90445-09777	HOSE (L300)	1	1	1	

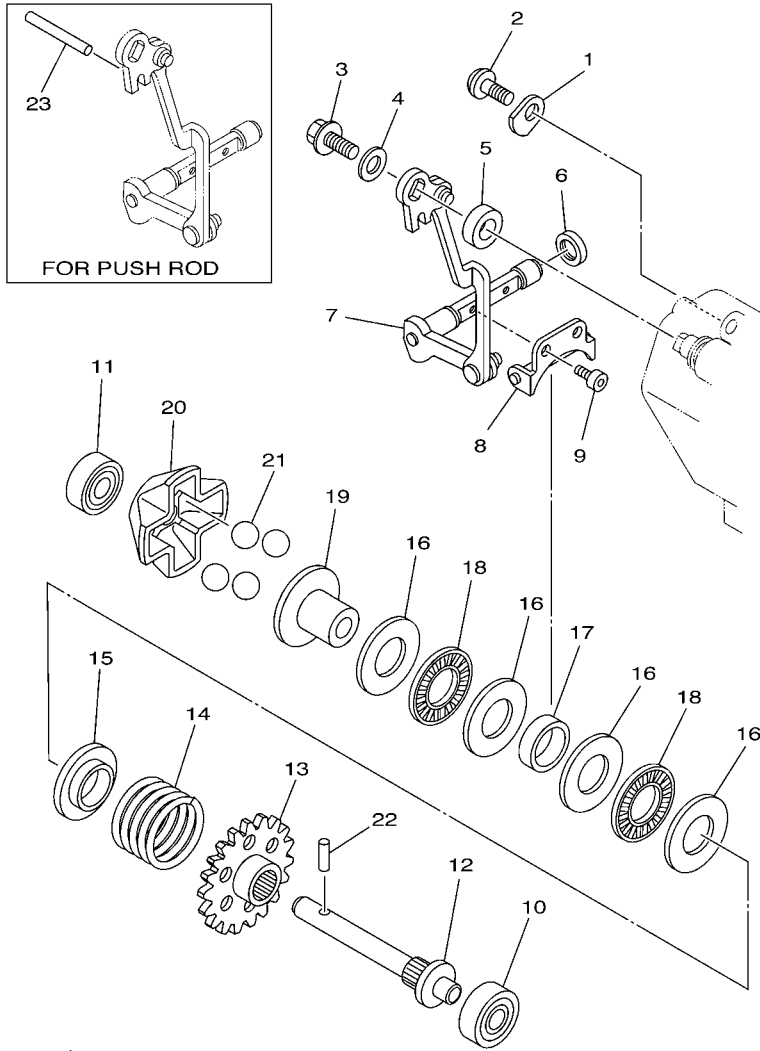

5NX1100-A020

FIG. 2 GOVERNOR

REF. NO.	PART NO.	DESCRIPTION	1S86	1S87	1S88	REMARKS
1	4JY-11915-10	PLATE, THRUST 1	1	1	1	
2	98902-05012	SCREW, BIND	1	1	1	
3	90105-05014	BOLT, FLANGE	1	1	1	
4	90201-05021	WASHER, PLATE	1	1	1	
5	90387-085E1	COLLAR	1	1	1	
6	93104-08040	OIL SEAL	1	1	1	
7	5CU-11990-10	PUSH ROD ASSY	1	1	1	
8	3JE-11922-01	FORK, GOVERNOR	1	1	1	
9	91312-04006	BOLT	2	2	2	
10	93300-60801	BEARING	1	1	1	KOYO
11	93300-60801	BEARING	1	1	1	KOYO
12	5X4-11921-02	SHAFT, GOVERNOR	1	1	1	
13	5NY-11953-00	GEAR, GOVERNOR	1	1	1	
14	90501-256L2	SPRING, COMPRESSION	1	1	1	
15	5CU-11952-00	PLATE	1	1	1	
16	90201-150U6	WASHER, PLATE	4	4	4	
17	90387-152F2	COLLAR	1	1	1	
18	93340-21505	BEARING	2	2	2	
19	5CU-11912-00	RETAINER, WEIGHT	1	1	1	
20	5CU-11911-00	RETAINER	1	1	1	
21	93507-16020	BALL	4	4	4	
22	93603-14240	PIN, DOWEL	1	1	1	
23	93604-29184	PIN, DOWEL	1	1	1	AP

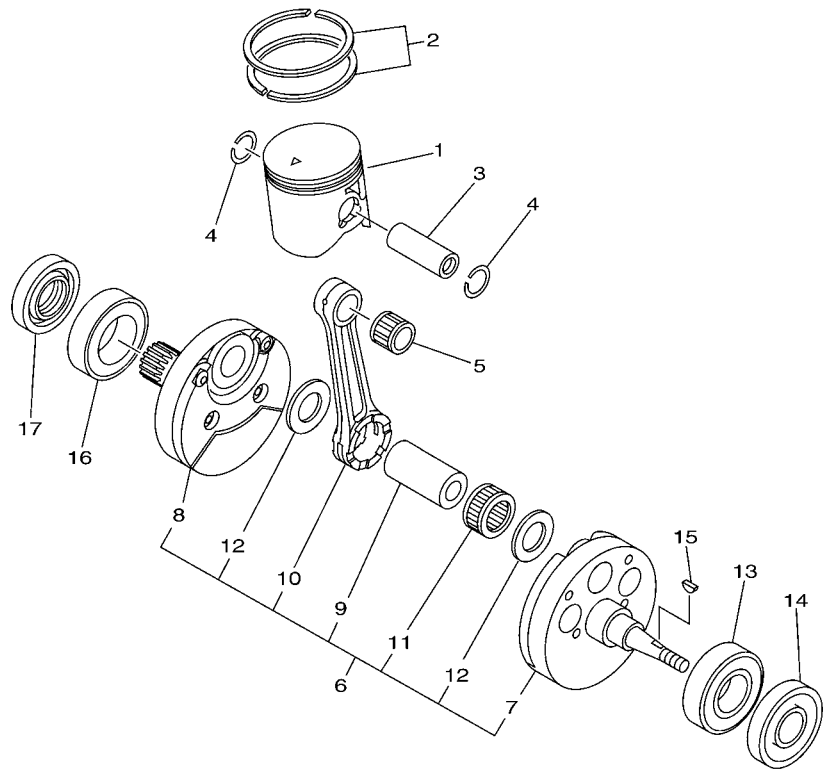

5MW1100-1030

FIG. 3 CRANKSHAFT & PISTON

REF. NO.	PART NO.	DESCRIPTION	1S86	1S87	1S88	REMARKS
1	1P8-11631-00-A0	PISTON (STD)	1	1	1	UR RED
	1P8-11631-00-B0	PISTON (STD)	1	1	1	UR ORANGE
	1P8-11631-00-C0	PISTON (STD)	1	1	1	UR GREEN
	1P8-11631-00-D0	PISTON (STD)	1	1	1	UR PURPLE
2	5CU-11603-10	PISTON RING SET (STD)	1	1	1	
3	5UP-11633-00	PIN, PISTON	1	1	1	
4	93450-19052	CIRCLIP	2	2	2	
5	93310-218A6	BEARING	1	1	1	
6	5UP-11400-10	CRANKSHAFT ASSY	1	1	1	
7	5UP-11410-10	.CRANKSHAFT	1	1	1	
8	5MW-11420-10	.CRANKSHAFT	1	1	1	
9	5CU-11681-00	.PIN, CRANK 1	1	1	1	
10	5MW-11651-00	.ROD, CONNECTING	1	1	1	
11	93310-52406	.BEARING	1	1	1	
12	90209-24327	.WASHER	2	2	2	
13	93306-37808	BEARING	1	1	1	
14	93102-20485	OIL SEAL	1	1	1	
15	90280-03045	KEY, WOODRUFF	1	1	1	
16	93306-37808	BEARING	1	1	1	
17	93102-28004	OIL SEAL	1	1	1	

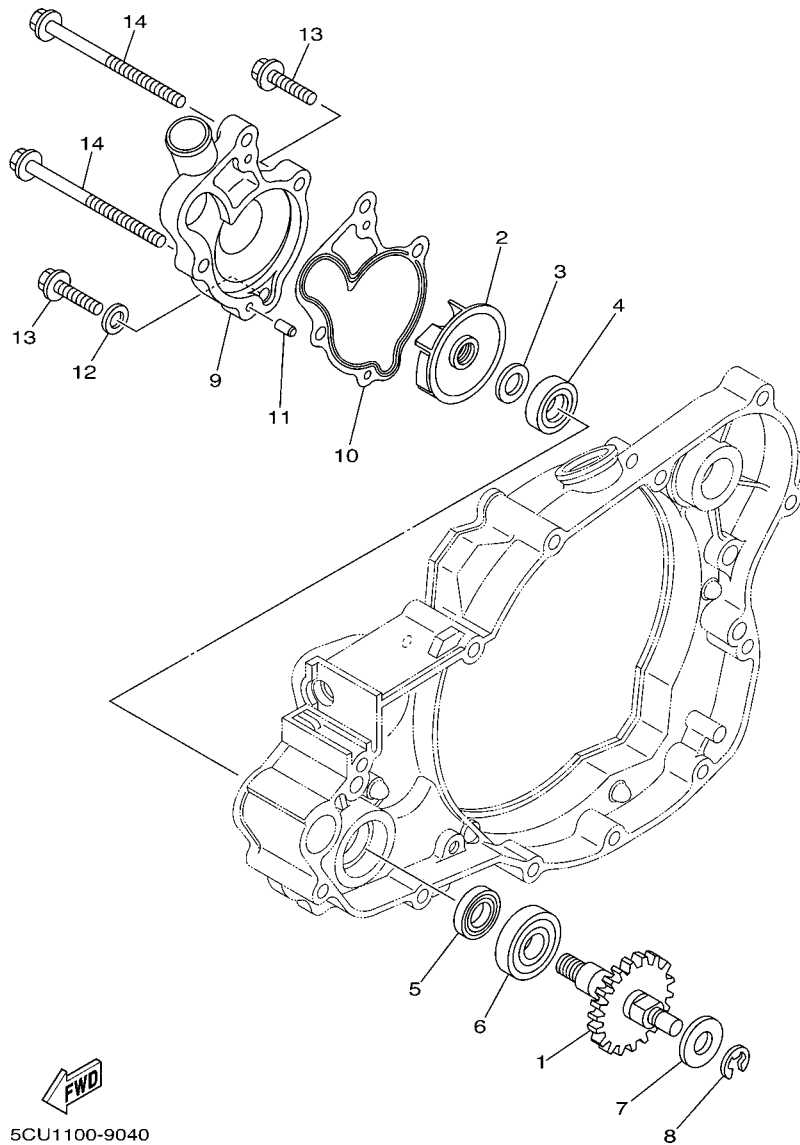
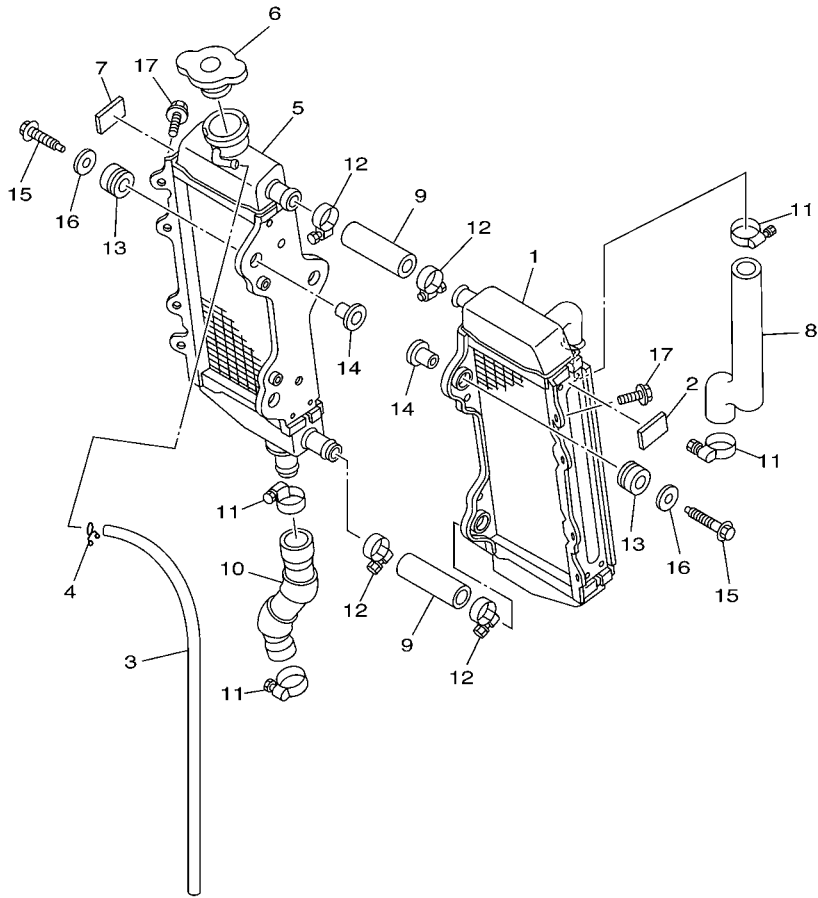

FIG. 4 WATER PUMP

REF. NO.	PART NO.	DESCRIPTION	1S86	1S87	1S88	REMARKS
1	5CU-12459-00	GEAR, IMPELLER SHAFT	1	1	1	
2	5DJ-12451-00	IMPELLER, WATER PUMP	1	1	1	
3	90201-08512	WASHER, PLATE	1	1	1	
4	93109-11073	OIL SEAL	1	1	1	
5	93102-12106	OIL SEAL (SD 12-22-5 HS)	1	1	1	
6	93306-00105	BEARING	1	1	1	
7	90201-08784	WASHER, PLATE	1	1	1	
8	99001-06600	CIRCLIP	1	1	1	
9	5MW-12422-00	COVER, HOUSING	1	1	1	
10	5XF-12428-00	GASKET, HOUSING COVER 2	1	1	1	
11	93604-10011	PIN, DOWEL	2	2	2	
12	90430-06014	GASKET	1	1	1	
13	95022-06025	BOLT, FLANGE	2	2	2	
14	95022-06065	BOLT, FLANGE	2	2	2	



1P81100-D050

FIG. 5 RADIATOR & HOSE

REF. NO.	PART NO.	DESCRIPTION	1S86	1S87	1S88	REMARKS
1	5NX-1240A-00	RADIATOR ASSY	1	1	1	
2	1C3-12465-00	DAMPER, RADIATOR	1	1	1	
3	91A20-05065	TUBE, FLEXIBLE VINYL	1	1	1	
4	90467-090A2	CLIP	1	1	1	
5	5NX-12461-00	RADIATOR COMP	1	1	1	
6	22W-12462-00	CAP, RADIATOR	1	1	1	
7	1C3-12465-00	DAMPER, RADIATOR	1	1	1	
8	5CU-12481-10	PIPE 1	1	1	1	
9	5NY-12482-00	PIPE 2	2	2	2	
10	1P8-12484-00	PIPE 4	1	1	1	
11	90450-28001	HOSE CLAMP ASSY	4	4	4	
12	90450-25001	HOSE CLAMP ASSY	4	4	4	
13	90480-15528	GROMMET	6	6	6	
14	90387-06065	COLLAR	6	6	6	
15	90105-06111	BOLT, FLANGE	6	6	6	
16	90201-06571	WASHER, PLATE	6	6	6	
17	90105-06118	BOLT, FLANGE	2	2	2	

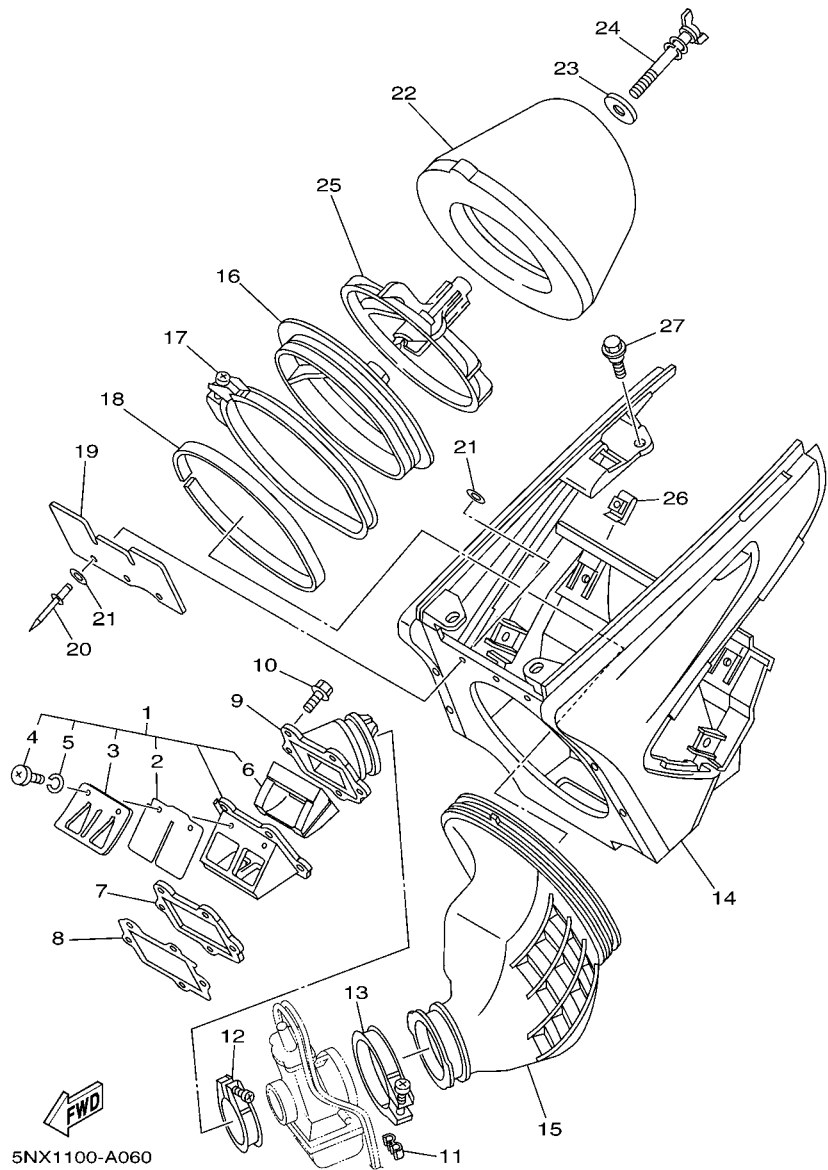
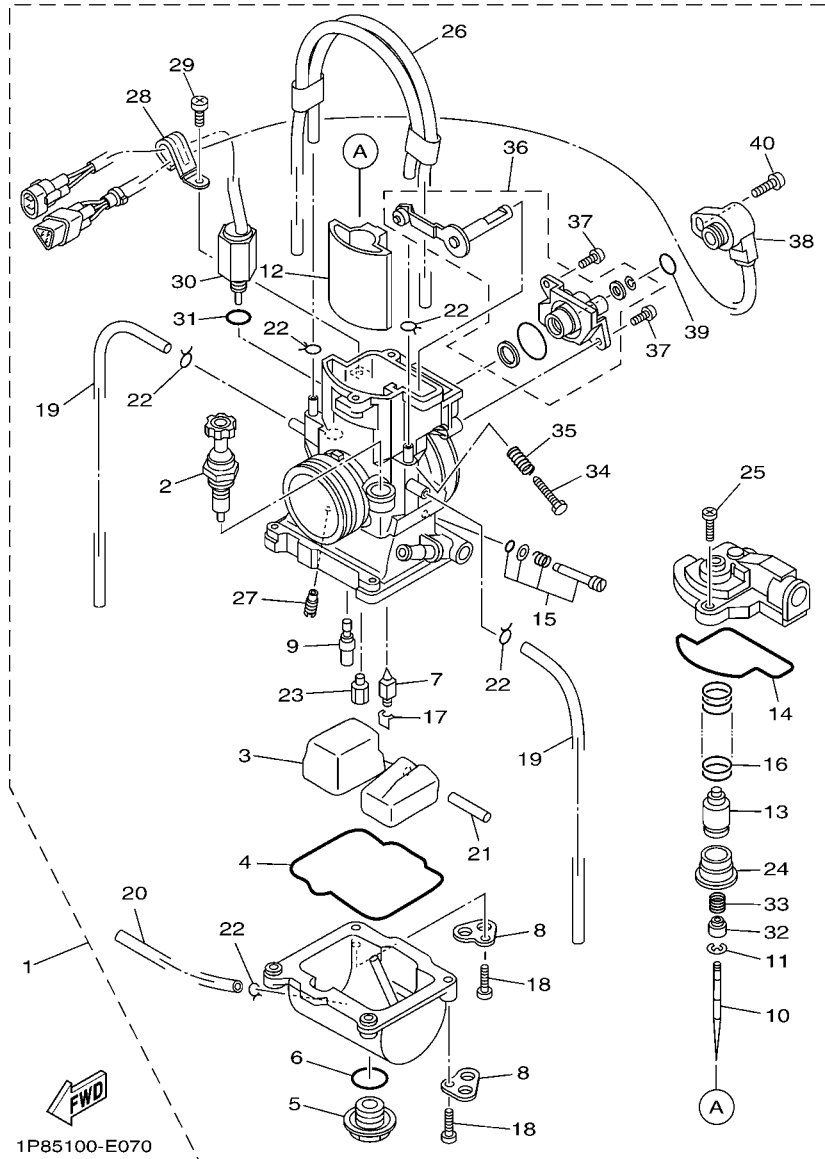

FIG. 6 INTAKE

REF. NO.	PART NO.	DESCRIPTION	1S86	1S87	1S88	REMARKS
1	5NX-13610-10	REED VALVE ASSY	1	1	1	
2	5NX-13613-00	.REED, VALVE	2	2	2	
3	4XL-13616-10	.STOPPER, REED VALVE	2	2	2	
4	98502-03008	.SCREW, PAN HEAD	4	4	4	
5	92902-03100	.WASHER	4	4	4	
6	4XL-13625-00	.SPACER, REED VALVE	1	1	1	
7	5NX-13624-00	PLATE, REED VALVE	1	1	1	
8	5XF-13622-00	GASKET, VALVE SEAT	1	1	1	
9	5NX-13565-00	JOINT, CARBURETOR	1	1	1	
10	91312-06025	BOLT	5	5	5	
11	90464-06214	CLAMP	2	2	2	
12	90450-51001	HOSE CLAMP ASSY	1	1	1	
13	90450-70003	HOSE CLAMP ASSY	1	1	1	
14	5NY-14401-01	AIR CLEANER CASE ASSY	1	1	1	
15	5NX-14453-00	JOINT, AIR CLEANER 1	1	1	1	
16	5NY-14459-00	HOLDER, GUIDE	1	1	1	
17	5NY-14455-20	BAND	1	1	1	
18	5NY-14442-00	SPACER	1	1	1	
19	5NY-14417-00	COVER 1	1	1	1	
20	90267-32070	RIVET, BLIND	3	3	3	
21	90201-03313	WASHER, PLATE	6	6	6	
22	4XM-14451-00	ELEMENT, AIR CLEANER	1	1	1	
23	90209-06096	WASHER	1	1	1	
24	90122-06005	BOLT, WING	1	1	1	
25	3JD-14458-01	GUIDE	1	1	1	
26	90183-06023	NUT, SPRING	4	4	4	
27	90109-06245	BOLT	4	4	4	



1P85100-E070

FIG. 7 CARBURETOR

REF. NO.	PART NO.	DESCRIPTION	1S86	1S87	1S88	REMARKS
1	1P8-14101-40	CARBURETOR ASSY 1	1		1	
	1P8-14101-50	CARBURETOR ASSY 1		1		
2	4JT-14171-00	.PLUNGER, STARTER	1	1	1	
3	4SR-14985-00	.FLOAT	1	1	1	
4	4JT-14984-00	.GASKET, FLOAT CHAMBER	1	1	1	
5	4MX-14115-00	.PLUG, SCREW	1	1	1	
6	4MX-14561-00	.O-RING	1	1	1	
7	4MX-14392-00	.VALVE, NEEDLE	1	1	1	
8	4XL-14146-00	.PLATE	2	2	2	
9	4MX-14948-08	.JET, SLOW (#52)	1		1	STD
	4MX-14948-07	.JET, SLOW (#50)		1		STD
	4MX-14948-12	.JET, SLOW (#62)	1	1	1	AP
	4MX-14948-11	.JET, SLOW (#60)	1	1	1	AP
	4MX-14948-10	.JET, SLOW (#58)	1	1	1	AP
	4MX-14948-09	.JET, SLOW (#55)	1	1	1	AP
	4MX-14948-08	.JET, SLOW (#52)		1		AP
	4MX-14948-07	.JET, SLOW (#50)	1		1	AP
	4MX-14948-06	.JET, SLOW (#48)	1	1	1	AP
	4MX-14948-05	.JET, SLOW (#45)	1	1	1	AP
	4MX-14948-04	.JET, SLOW (#42)	1	1	1	AP
	4MX-14948-03	.JET, SLOW (#40)	1	1	1	AP
	4MX-14948-02	.JET, SLOW (#38)	1	1	1	AP
10	4SR-14916-EW	.NEEDLE (N3EW)	1	1	1	STD
	4JT-14916-9G	.NEEDLE (N89G)	1	1	1	AP
	4JT-14916-9H	.NEEDLE (N89H)	1	1	1	AP
	4JT-14916-9W	.NEEDLE (N89W)	1	1	1	AP
	4JT-14916-9J	.NEEDLE (N89J)	1	1	1	AP

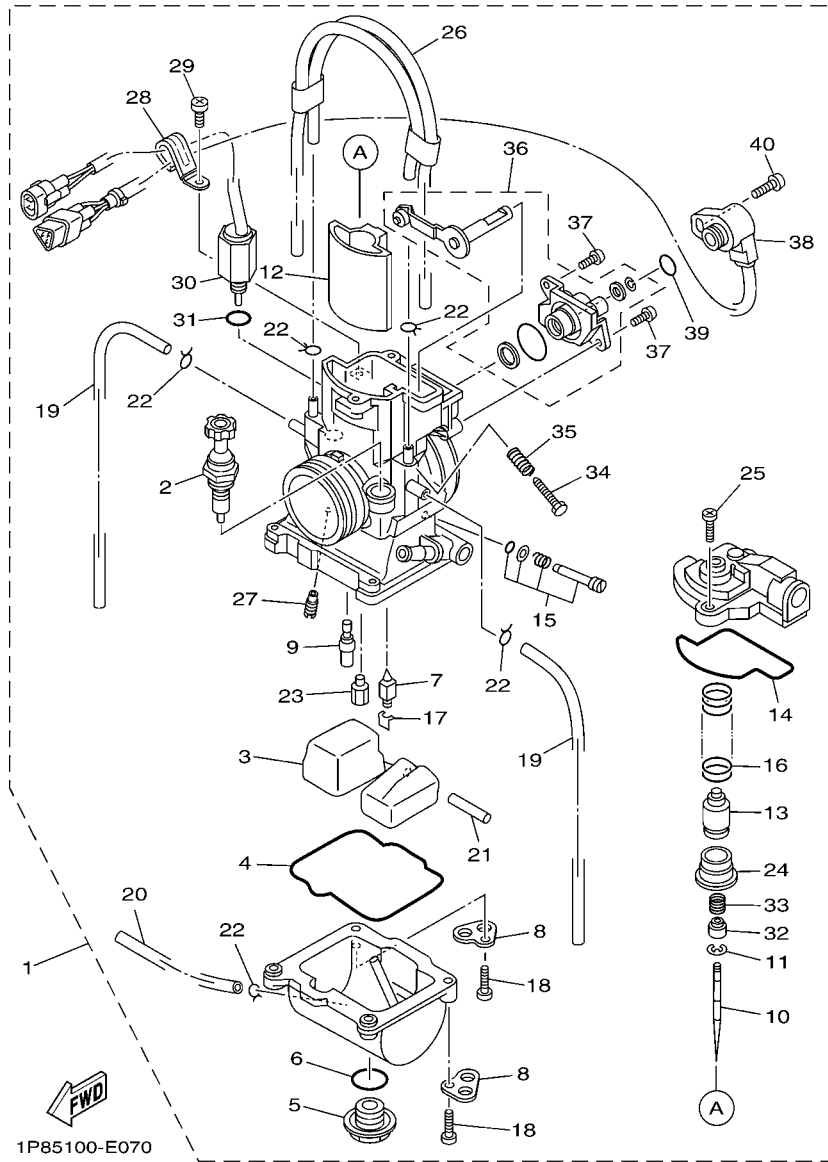

1P85100-E070

FIG. 7 CARBURETOR

REF. NO.	PART NO.	DESCRIPTION	1S86	1S87	1S88	REMARKS
10	4SR-14916-CG	.NEEDLE (N3CG)	1	1	1	AP
	4SR-14916-CH	.NEEDLE (N3CH)	1	1	1	AP
	4SR-14916-CW	.NEEDLE (N3CW)	1	1	1	AP
	4SR-14916-CJ	.NEEDLE (N3CJ)	1	1	1	AP
	4SR-14916-CK	.NEEDLE (N3CK)	1	1	1	AP
	4SR-14916-EG	.NEEDLE (N3EG)	1	1	1	AP
	4SR-14916-EH	.NEEDLE (N3EH)	1	1	1	AP
	4SR-14916-EJ	.NEEDLE (N3EJ)	1	1	1	AP
	4SR-14916-EK	.NEEDLE (N3EK)	1	1	1	AP
	4SR-14916-RH	.NEEDLE (N8RH)	1	1	1	AP
	4SR-14916-RW	.NEEDLE (N8RW)	1	1	1	AP
	4SR-14916-RJ	.NEEDLE (N8RJ)	1	1	1	AP
11	4MX-14919-00	.CLIP	1	1	1	
12	5HC-14340-A7	.VALVE ASSY	1	1	1	
13	5HC-14261-00	.HOLDER	1	1	1	
14	5HC-14126-00	.GASKET	1	1	1	
15	4SR-14105-00	.PILOT SCREW SET	1	1	1	
16	5HC-14131-00	.SPRING, THROTTLE VALVE	1	1	1	
17	663-14159-00	.CLIP	1	1	1	
18	98502-04014	.SCREW, PAN HEAD	4	4	4	
19	4XL-14197-10	.PIPE	2	2	2	
20	4XL-14196-10	.PIPE, OVER FLOW 1	1	1	1	
21	676-14548-00	.PIN, FLOAT ARM	1	1	1	
22	3TJ-14137-40	.CLIP	5	5	5	
23	4MX-14943-43	.JET, MAIN (#180)	1	1		STD
	4MX-14943-93	.JET, MAIN (#178)		1		STD
	4MX-14943-45	.JET, MAIN (#190)	1	1	1	AP

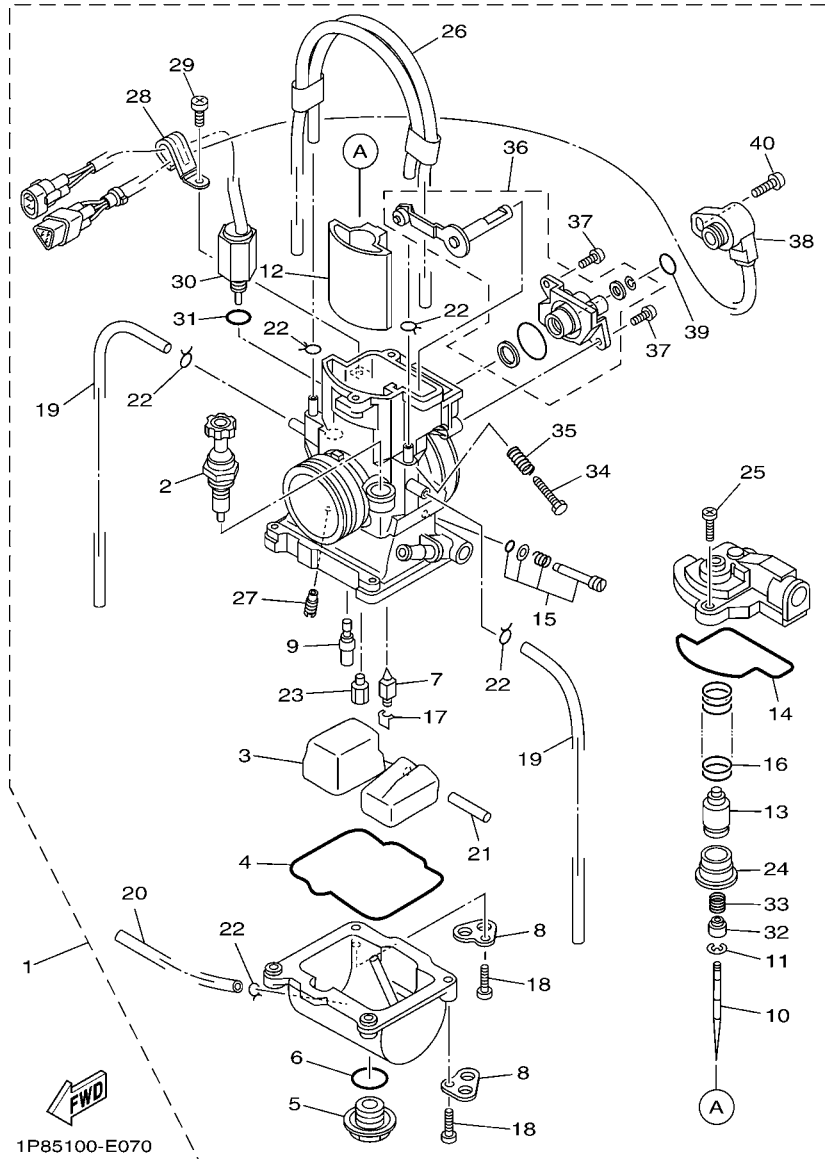
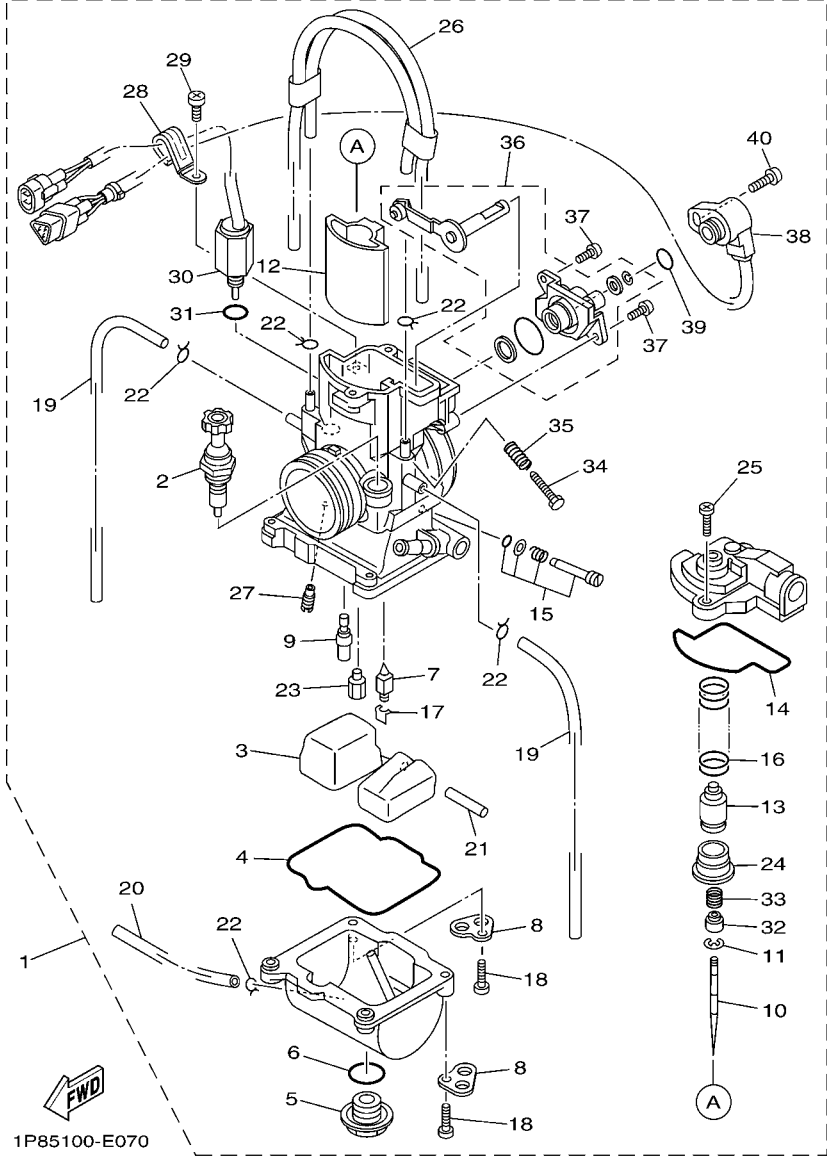

FIG. 7 CARBURETOR

REF. NO.	PART NO.	DESCRIPTION	1S86	1S87	1S88	REMARKS
23	4MX-14943-95	.JET, MAIN (#188)	1	1	1	AP
	4MX-14943-44	.JET, MAIN (#185)	1	1	1	AP
	4MX-14943-94	.JET, MAIN (#182)	1	1	1	AP
	4MX-14943-43	.JET, MAIN (#180)		1		AP
	4MX-14943-93	.JET, MAIN (#178)	1		1	AP
	4MX-14943-42	.JET, MAIN (#175)	1	1	1	AP
	4MX-14943-92	.JET, MAIN (#172)	1	1	1	AP
	4MX-14943-41	.JET, MAIN (#170)	1	1	1	AP
	4MX-14943-91	.JET, MAIN (#168)	1	1	1	AP
	4MX-14943-40	.JET, MAIN (#165)	1	1	1	AP
	4MX-14943-90	.JET, MAIN (#162)	1	1	1	AP
24	4MX-14194-00	.RING	1	1	1	
25	98502-04012	.SCREW, PAN HEAD	2	2	2	
26	4XL-1410E-00	.HOSE	1	1	1	
27	4JT-1494F-07	.JET (#50)	1	1	1	STD
	4JT-1494F-09	.JET (#55)	1	1	1	AP
	4JT-1494F-11	.JET (#60)	1	1	1	AP
	4JT-1494F-13	.JET (#65)	1	1	1	AP
	4JT-1494F-15	.JET (#70)	1	1	1	AP
	4JT-1494F-03	.JET (#40)	1	1	1	AP
28	5HC-14146-00	.PLATE	1	1	1	
29	98580-04006	.SCREW, PAN HEAD	1	1	1	
30	5NX-1410H-10	.FUEL CUT SOLENOID VALVE	1	1	1	
31	4JT-14147-00	.O-RING	1	1	1	
32	5HC-14264-00	.COLLAR	1	1	1	
33	5HC-14275-00	.SPRING	1	1	1	
34	5HC-14922-00	.SCREW, THROTTLE	1	1	1	

FIG. 7 CARBURETOR



1P85100-E070

REF. NO.	PART NO.	DESCRIPTION	1S86	1S87	1S88	REMARKS
35	5HC-14934-00	.SPRING, THROTTLE STOP	1	1	1	
36	1P8-14208-00	.LEVER COMP. 1	1	1	1	
37	5HC-14216-00	.SCREW	2	2	2	
38	5NX-85885-10	.THROTTLE SENSOR ASSY	1	1	1	
39	5NX-14562-00	.O-RING	1	1	1	
40	5NX-14216-00	.SCREW	1	1	1	

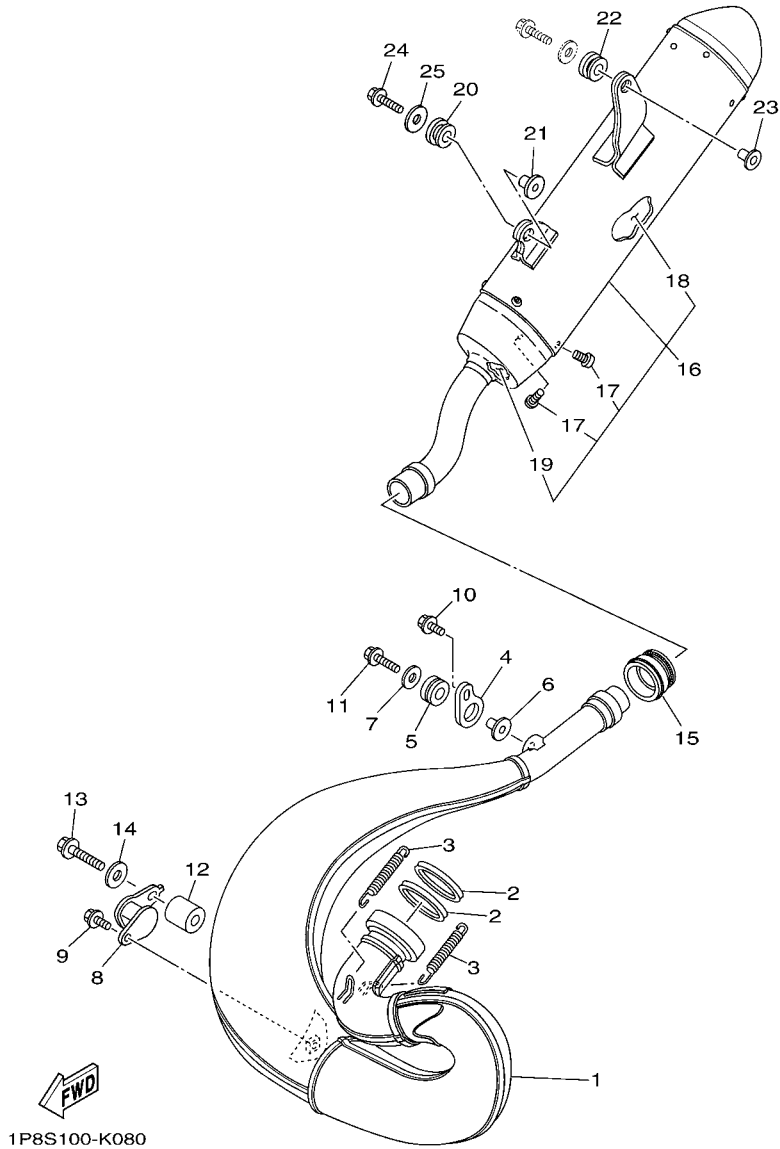

FIG. 8 EXHAUST

REF. NO.	PART NO.	DESCRIPTION	1S86	1S87	1S88	REMARKS
1	1P8-14610-10	EXHAUST PIPE ASSY 1	1		1	
	1P8-14610-00	EXHAUST PIPE ASSY 1		1		
2	5MW-14642-00	SEAL, EXHAUST	2	2	2	
3	90507-20052	SPRING, TENSION	2	2	2	
4	5CU-14771-01	STAY, MUFFLER 1	1	1	1	
5	90480-16561	GROMMET	1	1	1	
6	90387-063G3	COLLAR	1	1	1	
7	90201-06033	WASHER, PLATE	1	1	1	
8	5XF-14781-00	STAY, MUFFLER 2	1	1	1	
9	90119-06133	BOLT, WITH WASHER	1	1	1	
10	90119-06133	BOLT, WITH WASHER	1	1	1	
11	95022-06025	BOLT, FLANGE	1	1	1	
12	90387-08030	COLLAR	1	1	1	
13	90105-08136	BOLT, FLANGE	1	1	1	
14	90201-08049	WASHER, PLATE	1	1	1	
15	3JE-14615-01	JOINT, EXHAUST 1	1	1	1	
16	1P8-14753-00	SILENCER, EXHAUST	1	1	1	
17	92012-06010	.BOLT, BUTTON HEAD	4	4	4	
18	1P8-1469A-00	.FIBER	1	1	1	
19	1P8-1469E-00	.FIBER	1	1	1	
20	90480-17004	GROMMET	1	1	1	
21	90387-06121	COLLAR	1	1	1	
22	90480-16404	GROMMET	1	1	1	
23	90387-06039	COLLAR	1	1	1	
24	95022-06030	BOLT, FLANGE	1	1	1	
25	90201-06086	WASHER, PLATE	1	1	1	

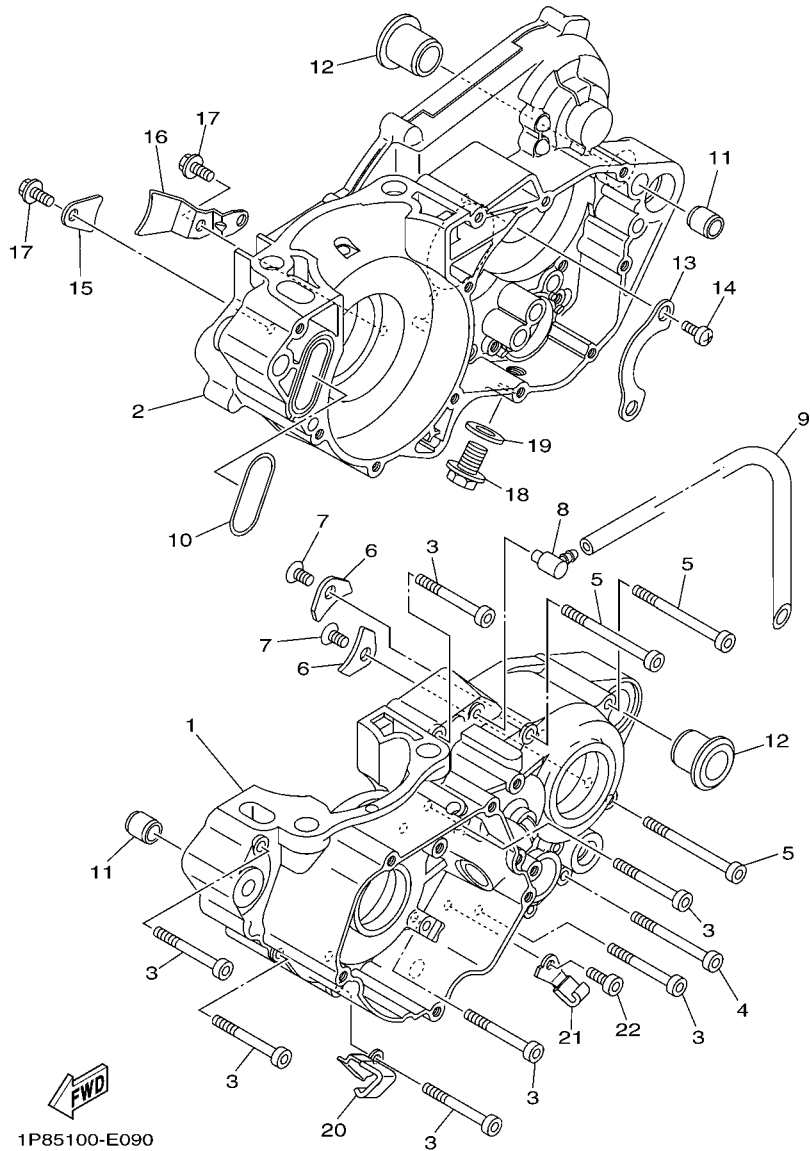

FIG. 9 CRANKCASE

REF. NO.	PART NO.	DESCRIPTION	1S86	1S87	1S88	REMARKS
1	1P8-15111-00-YX	CRANKCASE 1	1	1	1	
2	5NX-15121-00-YX	CRANKCASE 2	1	1	1	
3	91312-06050	BOLT	7	7	7	
4	91312-06060	BOLT	1	1	1	
5	91312-06070	BOLT	3	3	3	
6	4JT-15381-01	PLATE, BEARING COVER	2	2	2	
7	90149-06074	SCREW	2	2	2	
8	353-13115-01	CONNECTOR, SUCTION PIPE	1	1	1	
9	90445-08376	HOSE (L330)	1	1	1	
10	5CU-15454-00	GASKET 1	1	1	1	
11	93612-16254	PIN, DOWEL	2	2	2	
12	90387-18007	COLLAR	2	2	2	
13	4L0-17471-00	PLATE, COVER	1	1	1	
14	90157-06008	SCREW, PAN HEAD	2	2	2	
15	4V4-15118-00	HOLDER	1	1	1	
16	5CU-15118-10	HOLDER	1	1	1	
17	90105-06085	BOLT, FLANGE	2	2	2	
18	90340-12006	PLUG, STRAIGHT SCREW	1	1	1	
19	90430-12227	GASKET	1	1	1	
20	90462-08040	CLAMP	1	1	1	
21	90462-08041	CLAMP	1	1	1	
22	91312-06012	BOLT	1	1	1	

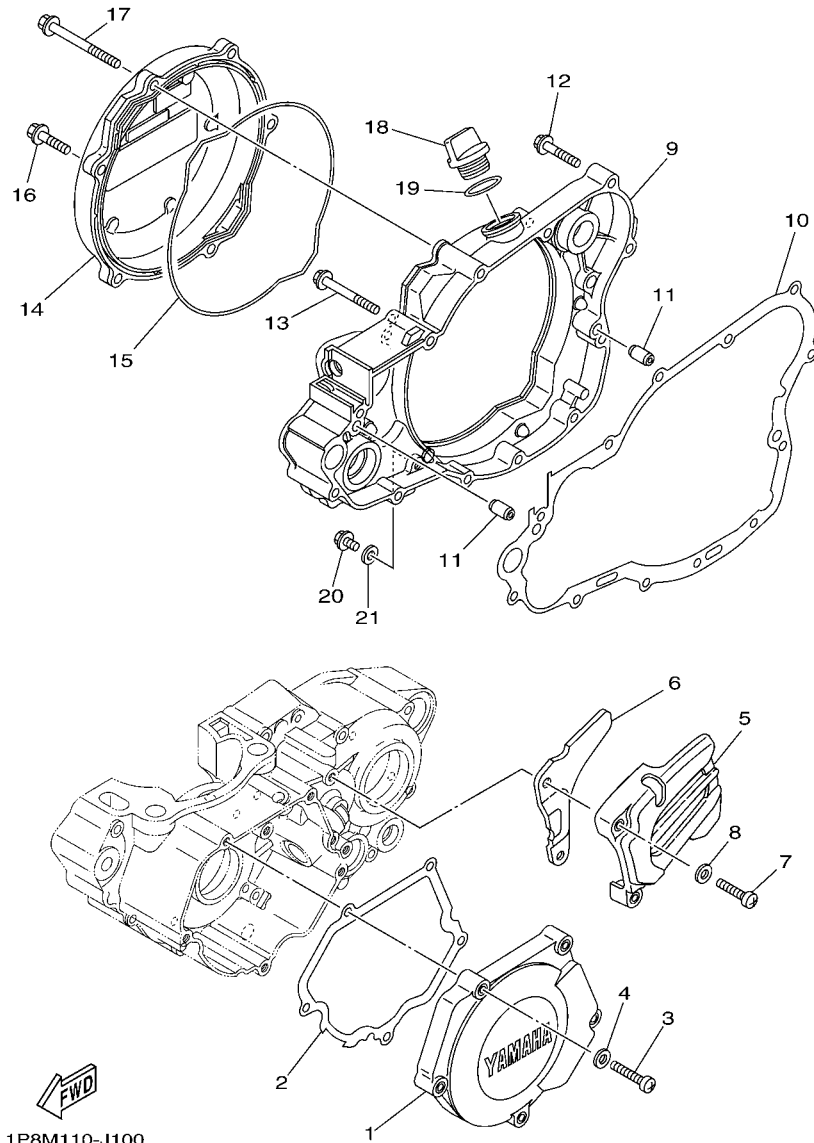

FIG. 10 CRANKCASE COVER 1

REF. NO.	PART NO.	DESCRIPTION	1SS6	1SS7	1SS8	REMARKS
1	5CU-15411-10	COVER, CRANKCASE 1	1	1	1	
2	5CU-15451-00	GASKET, CRANKCASE COVER 1	1	1	1	
3	92502-06030	SCREW, PAN HEAD	5	5	5	
4	92902-06600	WASHER, PLATE	5	5	5	
5	1P8-15421-10	COVER, CRANKCASE 2	1	1	1	
6	5HC-17466-00	GUIDE, CHAIN	1	1	1	
7	92502-06030	SCREW, PAN HEAD	2	2	2	
8	92902-06600	WASHER, PLATE	2	2	2	
9	5NX-15431-00	COVER, CRANKCASE 3	1	1	1	
10	5CU-15462-00	GASKET, CRANKCASE COVER 3	1	1	1	
11	99530-08016	PIN, DOWEL	2	2	2	
12	95022-06030	BOLT, FLANGE	8	8	8	
13	95022-06050	BOLT, FLANGE	1	1	1	
14	5MW-15415-20	COVER, GENERATOR	1	1	1	
15	5CU-15463-00	GASKET, COVER PINION 2	1	1	1	
16	95022-06025	BOLT, FLANGE	5	5	5	
17	95022-06065	BOLT, FLANGE	1	1	1	
18	3Y1-15363-10	PLUG, OIL	1	1	1	
19	93210-19123	O-RING	1	1	1	
20	95022-06010	BOLT, FLANGE	1	1	1	
21	90430-06014	GASKET	1	1	1	

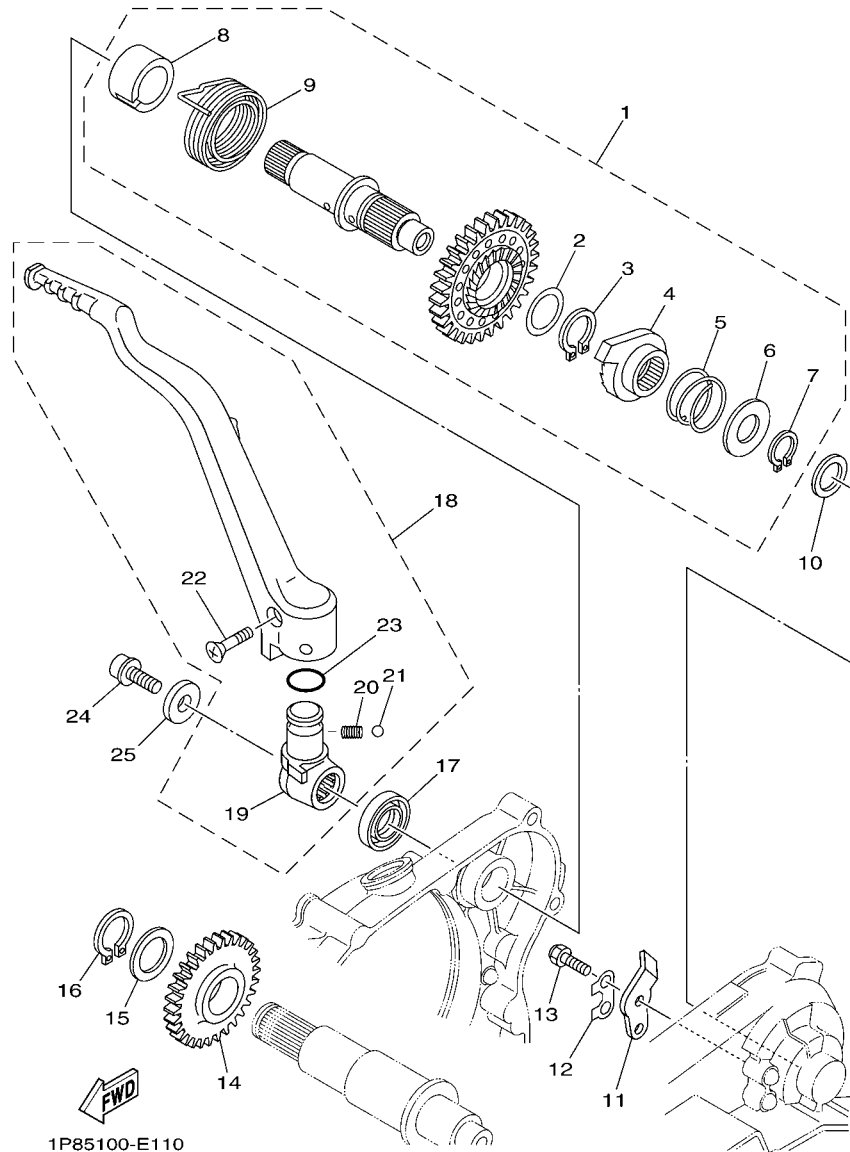
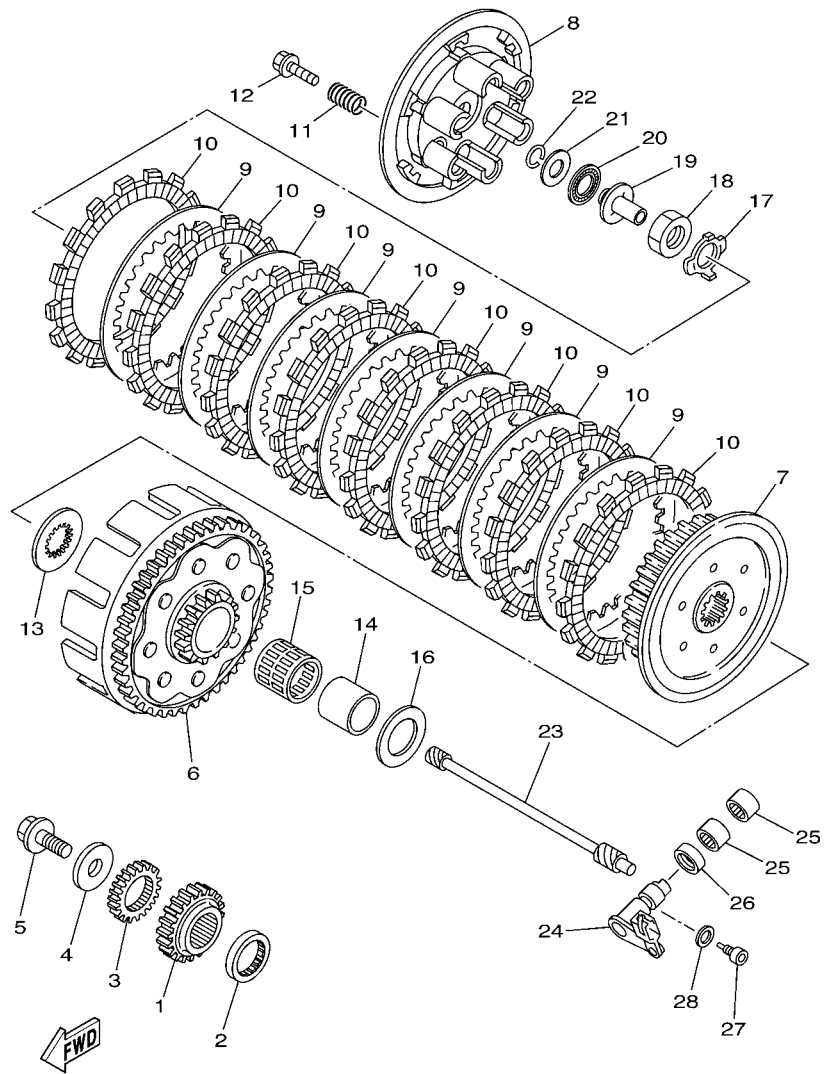

FIG. 11 STARTER

REF. NO.	PART NO.	DESCRIPTION	1S86	1S87	1S88	REMARKS
1	5NX-15601-10	KICK SHAFT ASSY	1	1	1	
2	90201-20685	.WASHER, PLATE (T=0.5)	1	1	1	
3	93410-20038	.CIRCLIP	1	1	1	
4	4GY-15671-00	.WHEEL, RATCHET	1	1	1	
5	90501-16016	.SPRING, COMPRESSION	1	1	1	
6	90201-167P7	.WASHER, PLATE	1	1	1	
7	99009-16400	.CIRCLIP	1	1	1	
8	5NL-15664-00	.GUIDE, SPRING	1	1	1	
9	90508-30743	.SPRING, TORSION	1	1	1	
10	90201-162H4	WASHER, PLATE	1	1	1	
11	214-15674-00	GUIDE, RATCHET WHEEL	1	1	1	
12	214-15686-00	WASHER, LOCK	1	1	1	
13	97022-06016	BOLT, HEXAGON	2	2	2	
14	5CU-15651-00	GEAR, KICK IDLE	1	1	1	
15	90201-20276	WASHER, PLATE (T=1.0)	1	1	1	
16	99009-20400	CIRCLIP	1	1	1	
17	93102-18278	OIL SEAL	1	1	1	
18	5NX-15620-20	KICK CRANK ASSY	1	1	1	
19	5NX-15621-10	.BOSS, KICK CRANK	1	1	1	
20	90501-147A5	.SPRING, COMPRESSION	1	1	1	
21	93507-32009	.BALL	1	1	1	
22	90151-06045	.SCREW, COUNTERSUNK	1	1	1	
23	93210-17570	.O-RING	1	1	1	
24	90110-08052	BOLT, HEXAGON SOCKET HEAD	1	1	1	
25	90201-08048	WASHER, PLATE	1	1	1	



5NX1100-A120

FIG. 12 CLUTCH

REF. NO.	PART NO.	DESCRIPTION	1SS6	1SS7	1SS8	REMARKS
1	5DJ-16111-00	GEAR, PRIMARY DRIVE	1	1	1	
2	5MW-16113-00	WASHER, THRUST 1	1	1	1	
3	5CU-11956-00	GEAR, GOVERNOR DRIVE	1	1	1	
4	90201-105P3	WASHER, PLATE	1	1	1	
5	90105-10445	BOLT, FLANGE	1	1	1	
6	5DJ-16150-00	PRIMARY DRIVEN GEAR COMP.	1	1	1	
7	5NX-16371-00	BOSS, CLUTCH	1	1	1	
8	5JG-16351-00	PLATE, PRESSURE 1	1	1	1	
9	4X7-16325-00	PLATE, CLUTCH 2	7	7	7	
10	3XK-16321-00	PLATE, FRICTION	8	8	8	
11	90501-237L0	SPRING, COMPRESSION	6	6	6	
12	90159-06010	SCREW, WITH WASHER	6	6	6	
13	5CU-16154-00	PLATE, THRUST 1	1	1	1	
14	2VM-16181-00	SPACER 1	1	1	1	
15	93310-230T7	BEARING	1	1	1	
16	2K7-16154-00	PLATE, THRUST 1	1	1	1	
17	90215-20231	WASHER, LOCK	1	1	1	
18	90170-20255	NUT	1	1	1	
19	4XL-16356-00	ROD, PUSH 1	1	1	1	
20	93340-21505	BEARING	1	1	1	
21	90201-125L6	WASHER, PLATE	1	1	1	
22	93440-10085	CIRCLIP	1	1	1	
23	1P8-16357-00	ROD, PUSH 2	1	1	1	
24	5CU-16380-10	PUSH LEVER ASSY	1	1	1	
25	93315-11206	BEARING	2	2	2	
26	93102-12224	OIL SEAL	1	1	1	
27	90109-05009	BOLT	1	1	1	

FIG. 12 CLUTCH

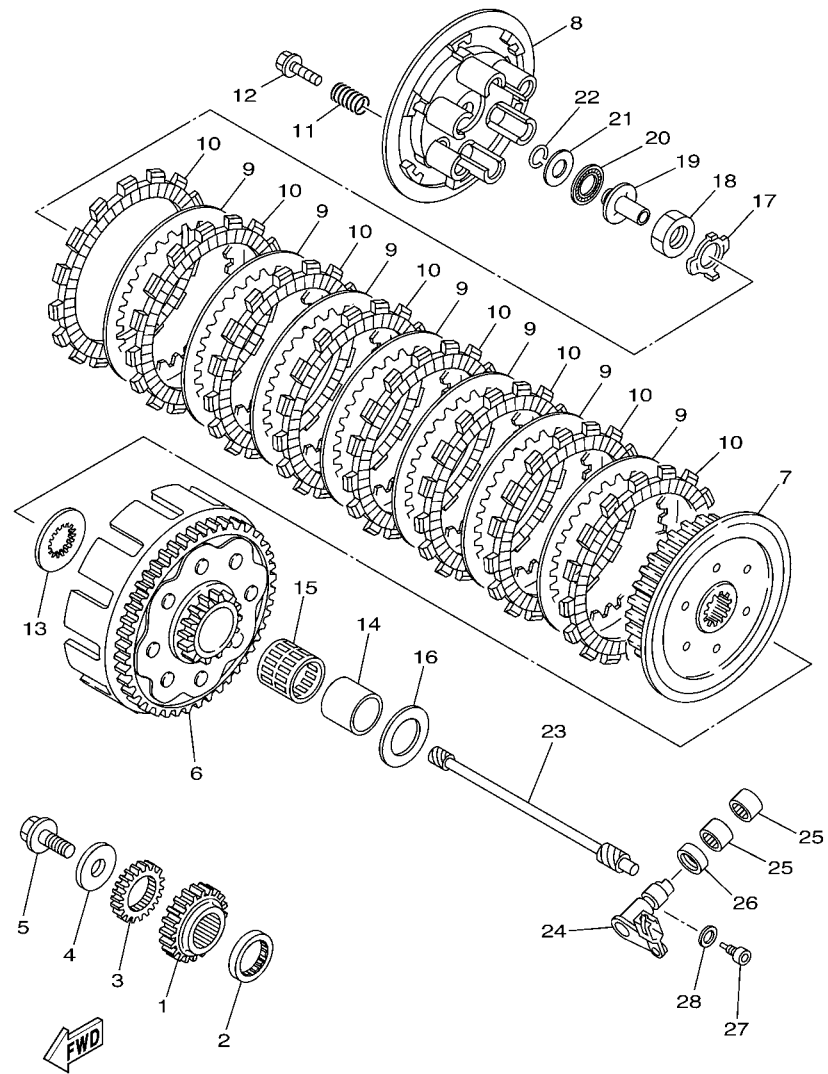

5NX1100-A120

REF. NO.	PART NO.	DESCRIPTION	1SS6	1SS7	1SS8	REMARKS
28	90430-05242	GASKET	1	1	1	
<hr style="border-top: 1px dashed black;"/>						
<hr style="border-top: 1px dashed black;"/>						
<hr style="border-top: 1px dashed black;"/>						
<hr style="border-top: 1px dashed black;"/>						
<hr style="border-top: 1px dashed black;"/>						
<hr style="border-top: 1px dashed black;"/>						
<hr style="border-top: 1px dashed black;"/>						

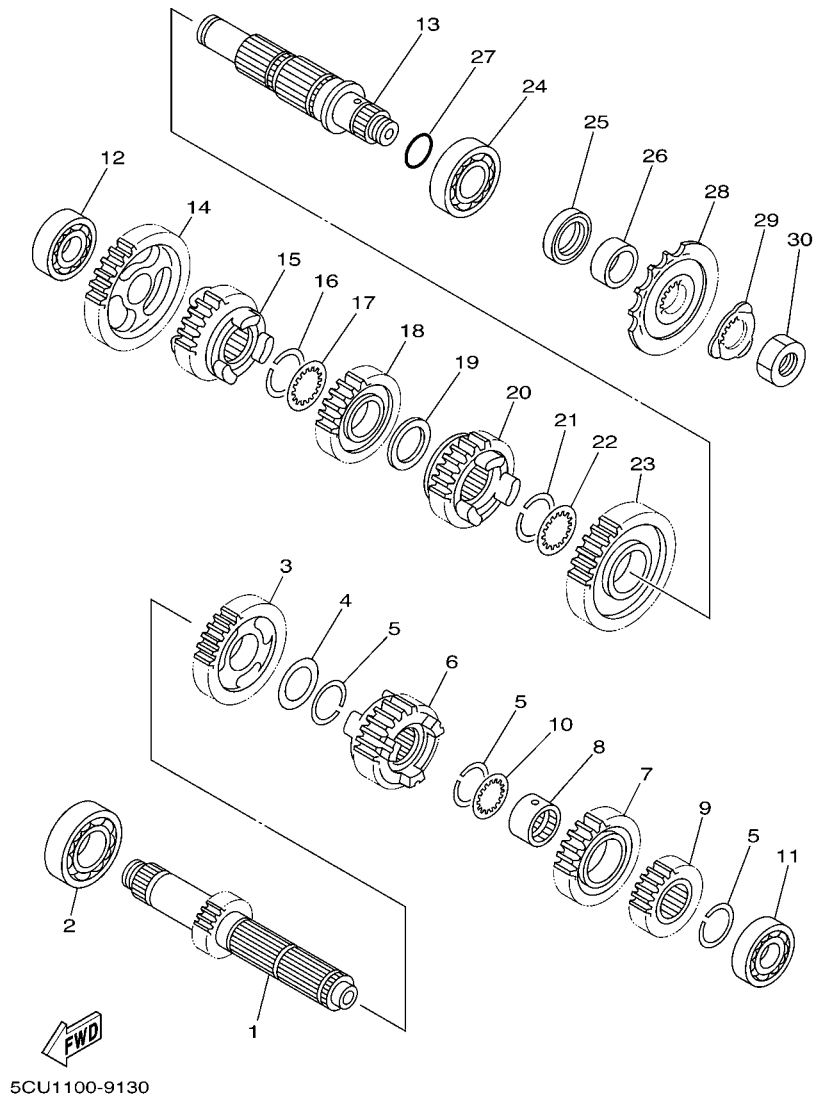
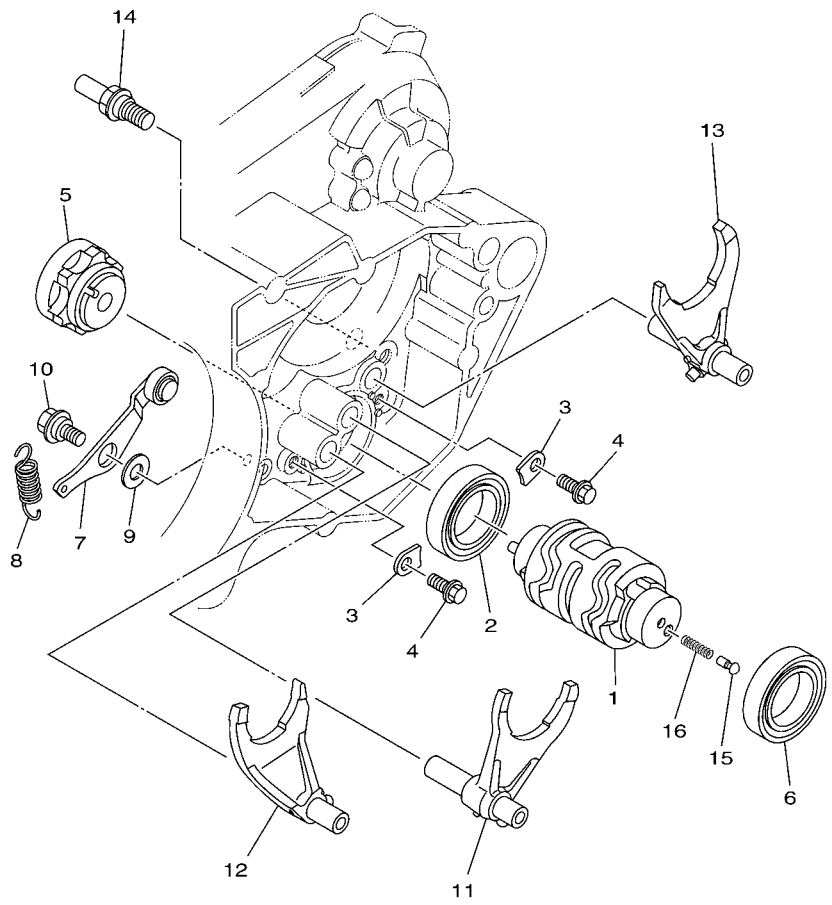

FIG. 13 TRANSMISSION

REF. NO.	PART NO.	DESCRIPTION	1S86	1S87	1S88	REMARKS
1	5BE-17411-00	AXLE, MAIN (14T)	1	1	1	
2	93306-20540	BEARING	1	1	1	
3	5BE-17151-00	GEAR, 5TH PINION (21T)	1	1	1	
4	90201-253K0	WASHER, PLATE (T=1.0)	1	1	1	
5	93440-25084	CIRCLIP	3	3	3	
6	5CU-17131-01	GEAR, 3RD PINION (18T)	1	1	1	
7	5BE-17141-30	GEAR, 4TH PINION (22T)	1	1	1	
8	90387-2113G	COLLAR	1	1	1	
9	5JG-17121-10	GEAR, 2ND PINION (15T)	1	1	1	
10	90209-21332	WASHER	1	1	1	
11	93306-00442	BEARING	1	1	1	
12	93306-00426	BEARING	1	1	1	
13	5BE-17402-00	DRIVE AXLE ASSY	1	1	1	
14	5BE-17211-00	GEAR, 1ST WHEEL (27T)	1	1	1	
15	5BE-17251-10	GEAR, 5TH WHEEL (20T)	1	1	1	
16	93440-25084	CIRCLIP	1	1	1	
17	90209-21332	WASHER	1	1	1	
18	5BE-17231-00	GEAR, 3RD WHEEL (23T)	1	1	1	
19	90201-253K0	WASHER, PLATE (T=1.0)	1	1	1	
20	5JG-17241-00	GEAR, 4TH WHEEL (24T)	1	1	1	
21	93440-28062	CIRCLIP	1	1	1	
22	90209-26348	WASHER	1	1	1	
23	5JG-17221-10	GEAR, 2ND WHEEL (23T)	1	1	1	
24	93306-20574	BEARING	1	1	1	
25	93102-32337	OIL SEAL	1	1	1	
26	90387-2515B	COLLAR	1	1	1	
27	93210-22298	O-RING	1	1	1	

FIG. 14 SHIFT CAM & FORK



FWD
1P85100-E140

REF. NO.	PART NO.	DESCRIPTION	1S86	1S87	1S88	REMARKS
1	1P8-18541-00	CAM, SHIFT	1	1	1	
2	93306-90506	BEARING	1	1	1	
3	5DH-18562-00	PLATE, STOPPER 2	2	2	2	
4	90105-06081	BOLT, FLANGE	2	2	2	
5	4EW-18185-00	SEGMENT	1	1	1	
6	93306-90501	BEARING	1	1	1	
7	5CU-18140-01	STOPPER LEVER ASSY	1	1	1	
8	90507-14064	SPRING, TENSION	1	1	1	
9	90201-06013	WASHER, PLATE	1	1	1	
10	90109-06198	BOLT	1	1	1	
11	5BE-18501-20	FORK, SHIFT 1	1	1	1	
12	5BE-18502-20	FORK, SHIFT 2	1	1	1	
13	5CU-18503-20	FORK, SHIFT 3	1	1	1	
14	4BR-18127-10	STOPPER, SCREW	1	1	1	
15	4UN-18542-00	POINT, NEUTRAL	1	1	1	
16	90501-06022	SPRING, COMPRESSION	1	1	1	

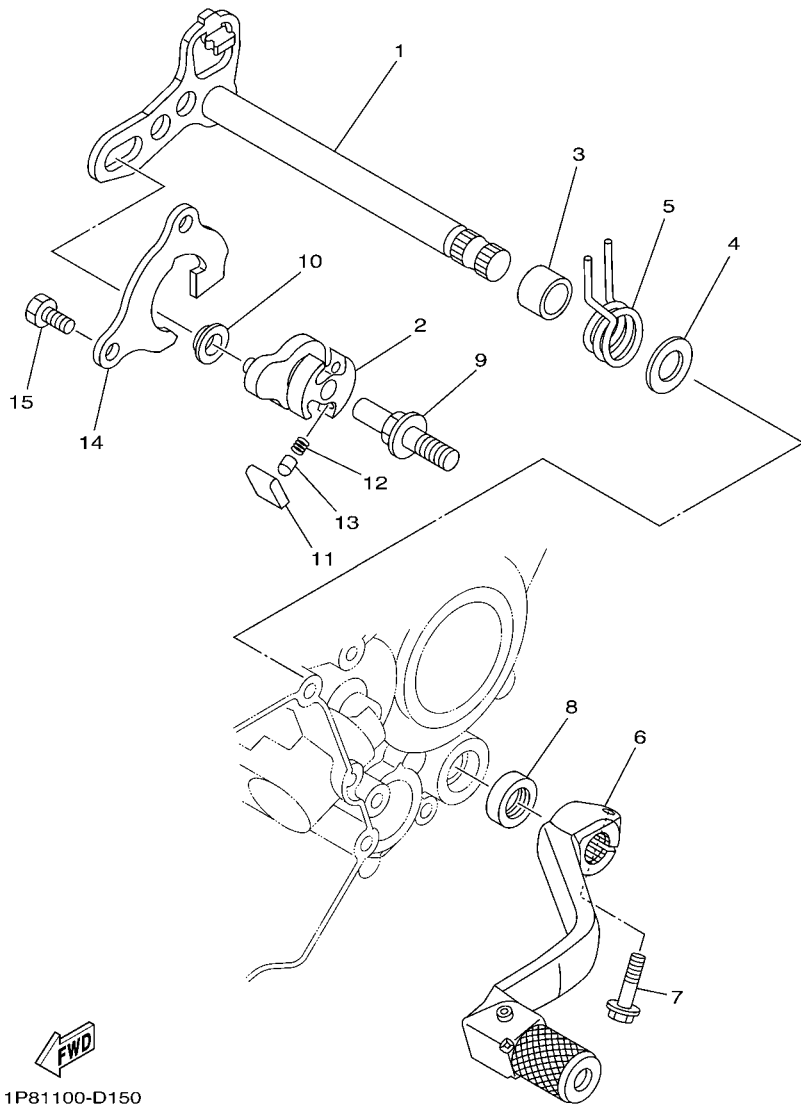

1P81100-D150

FIG. 15 SHIFT SHAFT

REF. NO.	PART NO.	DESCRIPTION	1S86	1S87	1S88	REMARKS
1	5CU-18101-10	SHIFT SHAFT ASSY	1	1	1	
2	5MW-18122-01	LEVER, SHIFT 2	1	1	1	
3	90387-124F4	COLLAR	1	1	1	
4	90201-12575	WASHER, PLATE	1	1	1	
5	90508-291A8	SPRING, TORSION	1	1	1	
6	1C3-18110-00	SHIFT PEDAL ASSY	1	1	1	
7	95022-06020	BOLT, FLANGE	1	1	1	
8	93102-12224	OIL SEAL	1	1	1	
9	3XJ-18173-10	PIN, SHIFT	1	1	1	
10	3XJ-18178-00	ROLLER, SHIFT LEVER	1	1	1	
11	3XJ-18182-00	PAWL, SHIFTER	2	2	2	
12	90501-052G5	SPRING, COMPRESSION	2	2	2	
13	3XJ-18184-00	PIN, PAWL	2	2	2	
14	5CU-18172-00	GUIDE, SHIFT	1	1	1	
15	90101-06041	BOLT	2	2	2	

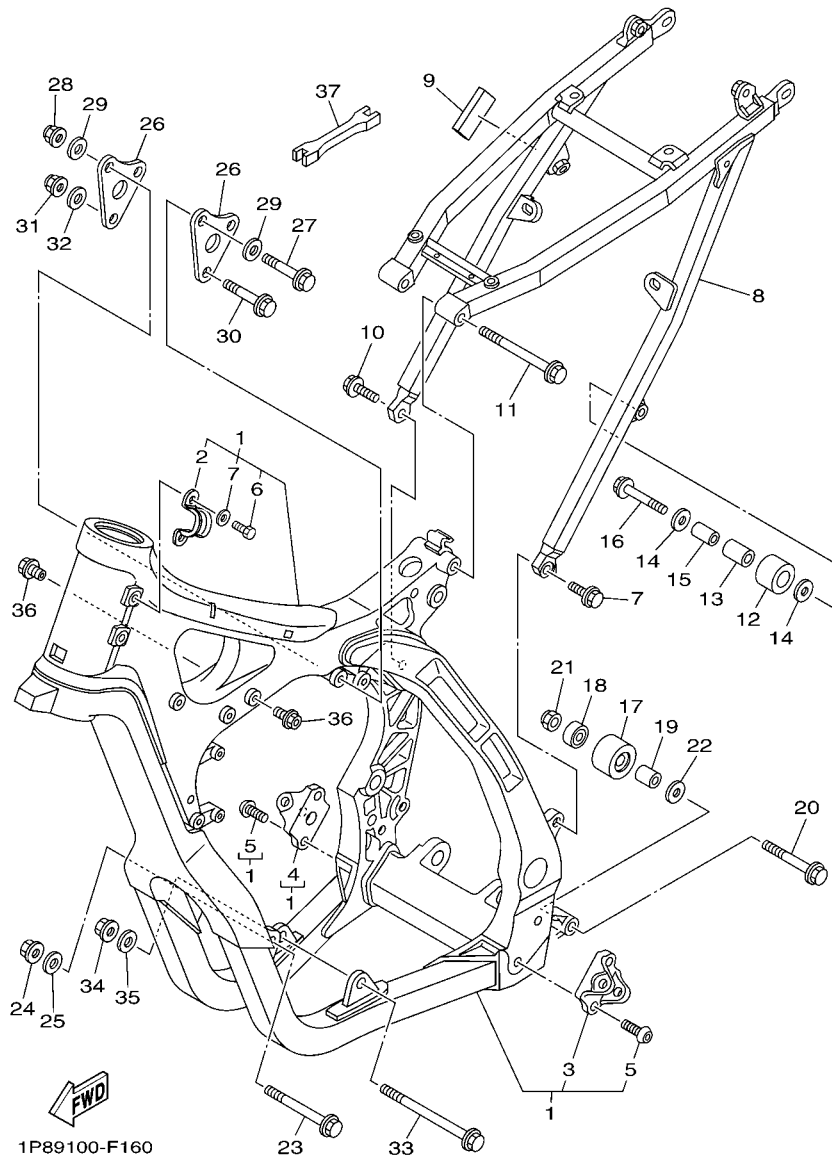
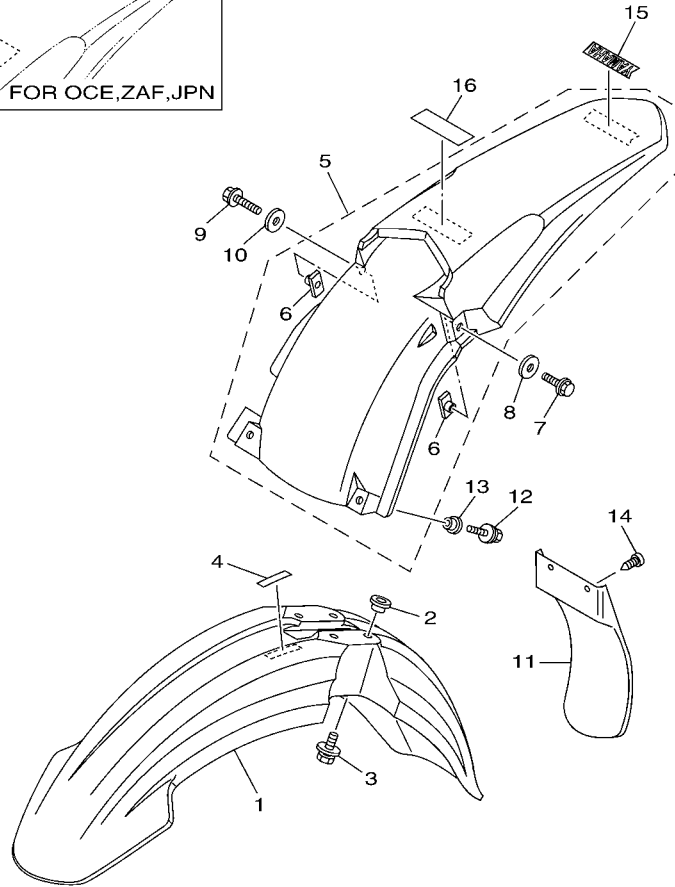
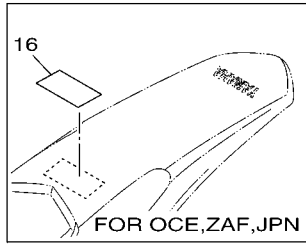

FIG. 16 FRAME

REF. NO.	PART NO.	DESCRIPTION	1S86	1S87	1S88	REMARKS
1	1P8-21101-50	FRONT FRAME COMP.	1	1	1	
2	1C3-21336-00	.CLAMP, WIRE HARNESS 2	1	1	1	
3	1C3-21447-10	.BRACKET, FOOTREST	1	1	1	
4	1C3-21448-10	.BRACKET, FOOTREST	1	1	1	
5	90149-10031	.SCREW	4	4	4	
6	97004-05012	.BOLT	2	2	2	
7	92904-05600	.WASHER	2	2	2	
8	1C3-21190-90	REAR FRAME COMP.	1	1	1	
9	5GJ-21717-00	DAMPER	1	1	1	
10	90105-08085	BOLT, FLANGE	2	2	2	
11	90105-08132	BOLT, FLANGE	1	1	1	
12	30X-22178-00	TENSIONER	1	1	1	
13	4V4-22184-00	BUSH	1	1	1	
14	90201-08045	WASHER, PLATE	2	2	2	
15	90387-08041	COLLAR	1	1	1	
16	95022-08040	BOLT, FLANGE	1	1	1	
17	3JD-22178-20	TENSIONER	1	1	1	
18	93300-60839	BEARING	1	1	1	
19	90387-086N4	COLLAR	1	1	1	
20	90105-08133	BOLT, FLANGE	1	1	1	
21	90185-08009	NUT, SELF-LOCKING	1	1	1	
22	90201-08043	WASHER, PLATE	1	1	1	
23	90105-10172	BOLT, FLANGE	1	1	1	
24	90179-10658	NUT	1	1	1	
25	92902-10200	WASHER	1	1	1	
26	5NX-21425-00	BRACKET, REAR UPPER 1	2	2	2	
27	90105-08131	BOLT, FLANGE	2	2	2	



1SR1100-L170

FIG. 17 FENDER

REF. NO.	PART NO.	DESCRIPTION	1S86	1S87	1S88	REMARKS
1	1C3-21511-51	FENDER, FRONT	1	1	1	
2	90387-06090	COLLAR	4	4	4	
3	90119-06147	BOLT, WITH WASHER	4	4	4	
4	3XJ-2415E-C1	LABEL, CAUTION		1		
5	5XE-21610-20	REAR FENDER COMP.	1	1	1	
6	5XE-21635-10	.NUT, REAR FENDER	2	2	2	
7	90105-06099	BOLT, FLANGE	1	1	1	
8	90201-06032	WASHER, PLATE	1	1	1	
9	90105-06101	BOLT, FLANGE	1	1	1	
10	90201-06033	WASHER, PLATE	1	1	1	
11	5TA-21642-00	GUARD, FLAP	1	1	1	
12	90119-06149	BOLT, WITH WASHER	2	2	2	
13	90387-06009	COLLAR	2	2	2	
14	97702-60016	SCREW, TAPPING	2	2	2	
15	4ES-2153E-20	EMBLEM, YAMAHA	1	1	1	
16	5PG-2816R-00	LABEL, WARNING GENERAL INFO.	1			
	5PA-2118K-20	LABEL, CAUTION		1		
	5PA-2118K-00	LABEL, CAUTION			1	

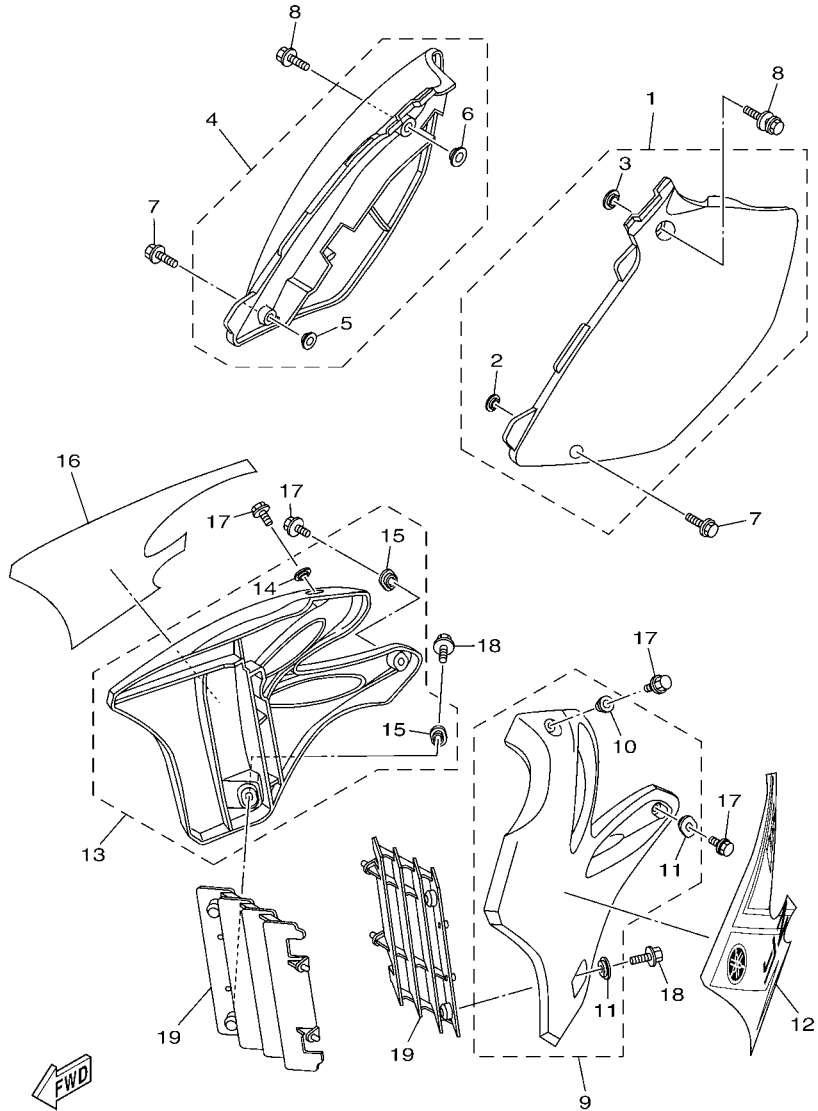

1SR5110-M180

FIG. 18 SIDE COVER

REF. NO.	PART NO.	DESCRIPTION	1S86	1S87	1S88	REMARKS
1	5NY-21711-00	COVER, SIDE 1	1	1	1	
2	90387-06009	.COLLAR	1	1	1	
3	5BE-21749-00	.COLLAR	1	1	1	
4	1C3-21721-50	COVER, SIDE 2	1	1	1	
5	90387-06009	.COLLAR	1	1	1	
6	5BE-21749-00	.COLLAR	1	1	1	
7	90105-06103	BOLT, FLANGE	2	2	2	
8	90119-08095	BOLT, WITH WASHER	2	2	2	
9	5XE-21730-00	SIDE COVER ASSY 3	1	1	1	
10	90387-06009	.COLLAR	1	1	1	
11	5TA-21749-00	.COLLAR	2	2	2	
12	1SR-2173E-10	GRAPHIC 1	1	1	1	
13	5XE-21740-00	SIDE COVER ASSY 4	1	1	1	
14	90387-06009	.COLLAR	1	1	1	
15	5TA-21749-00	.COLLAR	2	2	2	
16	1SS-2173F-10	GRAPHIC 2	1	1	1	
17	90105-06064	BOLT, FLANGE	4	4	4	
18	90159-06021	SCREW, WITH WASHER	2	2	2	
19	5NL-2172A-20	PANEL 1	2	2	2	

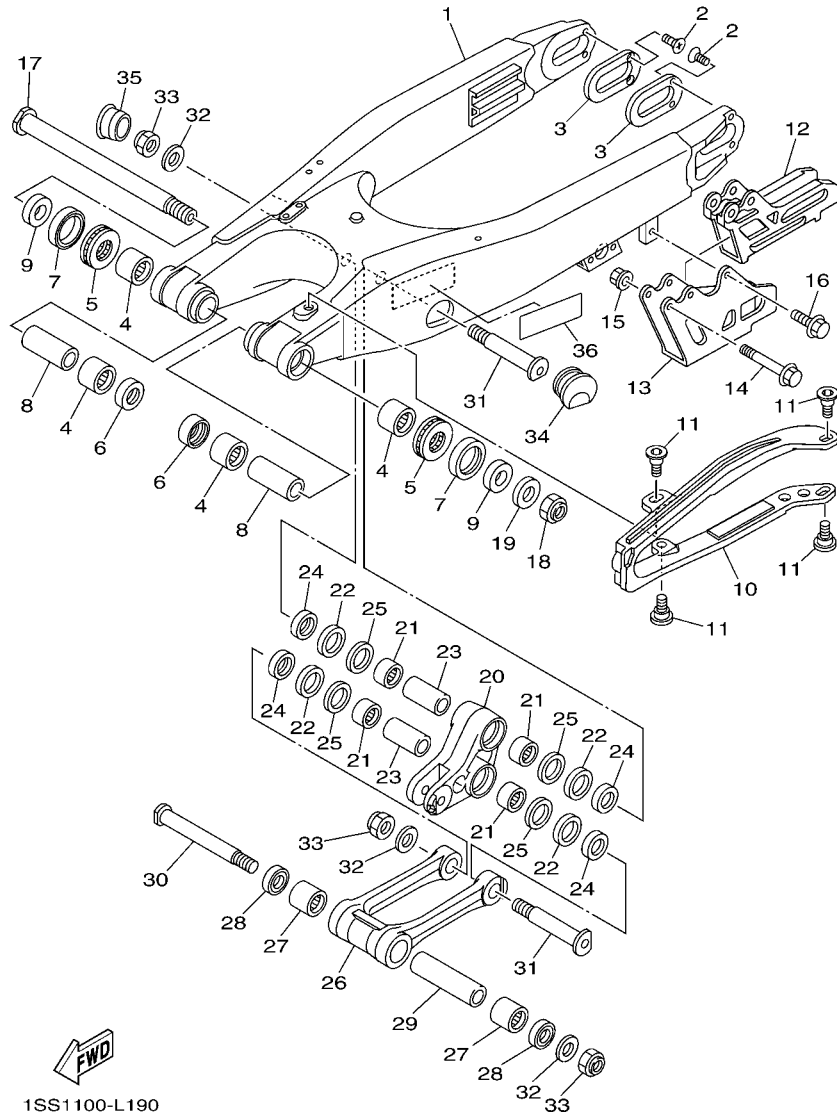

1SS1100-L190

FIG. 19 REAR ARM

REF. NO.	PART NO.	DESCRIPTION	1SS6	1SS7	1SS8	REMARKS
1	1C3-22110-90	REAR ARM COMP.	1	1	1	
2	90151-04003	SCREW, COUNTERSUNK	4	4	4	
3	1P8-22355-00	PATCH	2	2	2	
4	93317-22262	BEARING	4	4	4	
5	93342-22217	BEARING	2	2	2	
6	93106-22002	OIL SEAL	2	2	2	
7	93109-28043	OIL SEAL	2	2	2	
8	90387-18004	COLLAR	2	2	2	
9	90387-18012	COLLAR	2	2	2	
10	2S2-22151-70	SEAL, GUARD	1	1	1	
11	1C3-22969-90	SCREW, 1	4	4	4	
12	2S2-22199-70	SUPPORT, CHAIN	1	1	1	
13	2S2-22128-70	COVER, THRUST 1	1	1	1	
14	90105-06104	BOLT, FLANGE	2	2	2	
15	90179-06028	NUT	2	2	2	
16	90105-06105	BOLT, FLANGE	1	1	1	
17	1C3-22141-10	SHAFT, PIVOT	1	1	1	
18	90185-16002	NUT, SELF-LOCKING	1	1	1	
19	90201-16018	WASHER, PLATE	1	1	1	
20	1C3-2217A-00	ARM, RELAY	1	1	1	
21	93315-32166	BEARING	4	4	4	
22	93109-25001	OIL SEAL	4	4	4	
23	90387-16025	COLLAR	2	2	2	
24	90209-16011	WASHER	4	4	4	
25	90201-21014	WASHER, PLATE	4	4	4	
26	1C3-2217F-50	ROD, CONNECTING 1	1	1	1	
27	93315-32166	BEARING	2	2	2	

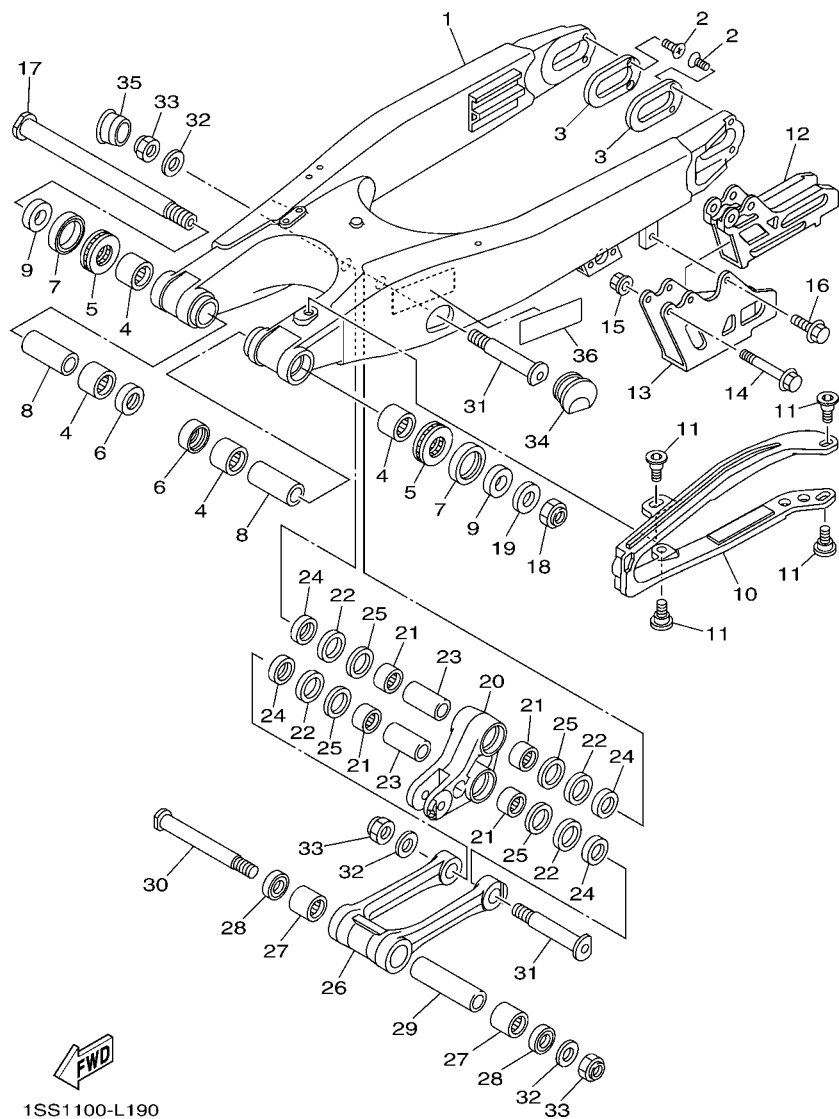

1SS1100-L190

FIG. 19 REAR ARM

REF. NO.	PART NO.	DESCRIPTION	1SS6	1SS7	1SS8	REMARKS
28	93109-21001	OIL SEAL	2	2	2	
29	90387-14016	COLLAR	1	1	1	
30	1C3-22121-00	SHAFT 1	1	1	1	
31	1C3-22122-00	SHAFT 2	2	2	2	
32	90201-14020	WASHER, PLATE	3	3	3	
33	90185-14010	NUT, SELF-LOCKING	3	3	3	
34	1C3-2135F-00	COVER	1	1	1	
35	1C3-2139R-00	COVER 2	1	1	1	
36	3RV-21668-A0	LABEL, TIRE			1	

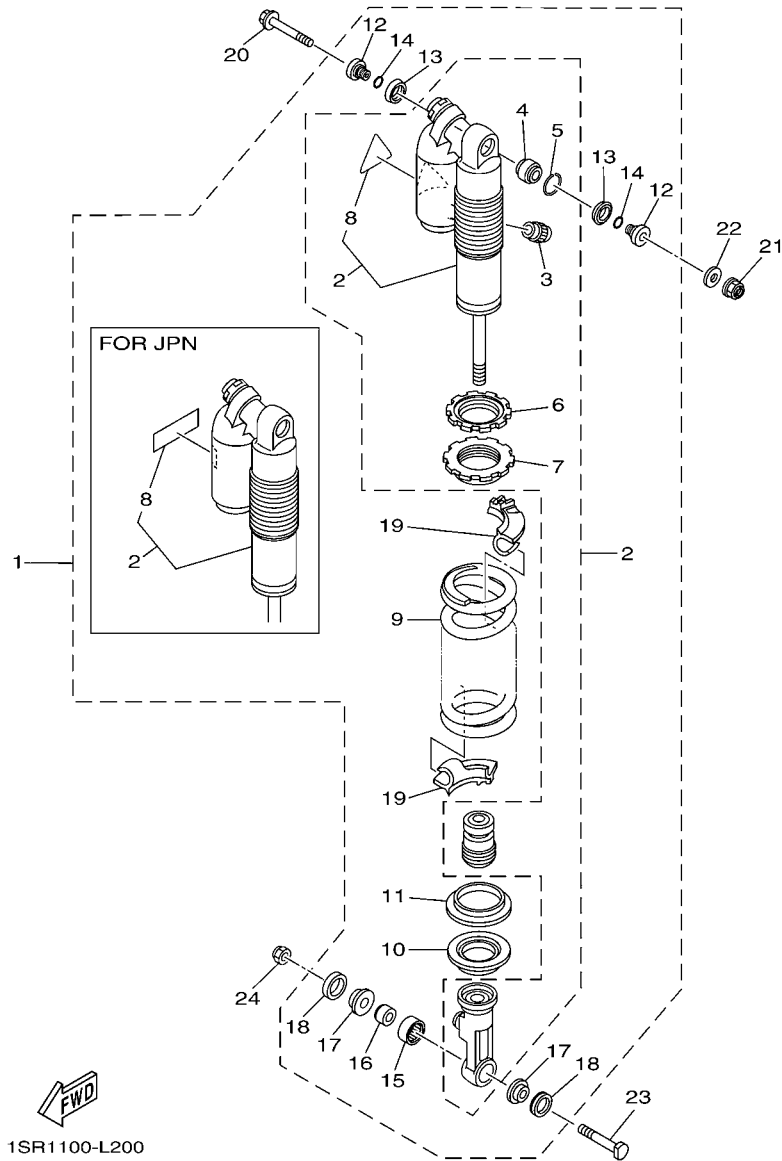
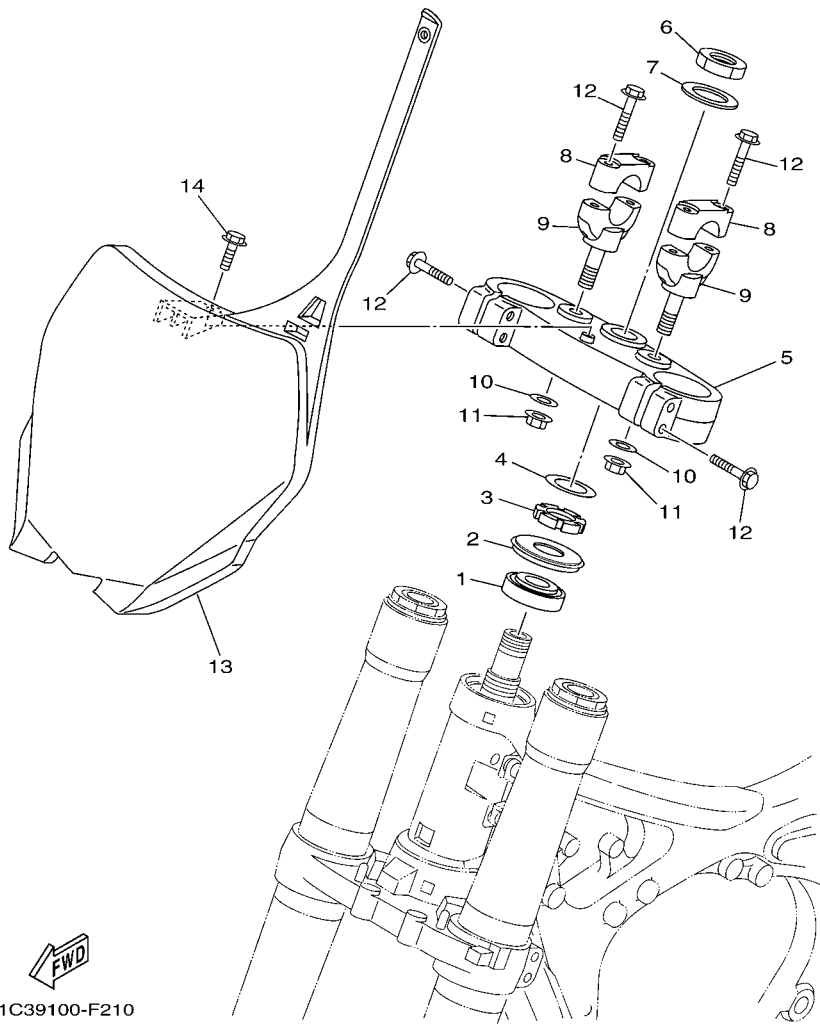

FIG. 20 REAR SUSPENSION

REF. NO.	PART NO.	DESCRIPTION	1SS6	1SS7	1SS8	REMARKS
1	1SS-22200-20	SHOCK ABSORBER ASSY, REAR	1			
	1SS-22200-30	SHOCK ABSORBER ASSY, REAR		1		
	1P8-22200-J1	SHOCK ABSORBER ASSY, REAR			1	
2	1P8-22201-G0	.DAMPER SUB ASSY	1			
	1P8-22201-H0	.DAMPER SUB ASSY		1		
	1P8-22201-J0	.DAMPER SUB ASSY			1	
3	509-23184-L0	..CAP, AIR VALVE	1	1	1	
4	4JX-22226-00	..BUSH, SHOCK ABSORBER LOWER	1	1	1	
5	5DH-23183-00	..CIRCLIP	1	1	1	
6	3SP-22234-00	..GUIDE, SPRING 3	1	1	1	
7	1C3-22213-L0	..SEAT, SPRING UPPER	1	1	1	
8	4AA-22259-40	..LABEL, WARNING	1	1		
	4AA-22259-50	..LABEL, WARNING		1		
9	5UN-22212-30	.SPRING (K=48N/MM)	1	1		
	1C3-22212-20	.SPRING (K=48N/MM)			1	
10	1C3-22214-50	..GUIDE, SPRING 1	1	1	1	
11	5MV-22224-00	.GUIDE, SPRING 2	1	1	1	
12	1C3-22253-50	.COLLAR, DISTANCE	2	2	2	
13	3JE-22475-00	.SEAL, DUST	2	2	2	
14	4EW-22474-00	.SEAL, RING	2	2	2	
15	5UN-22176-00	.BEARING	1	1	1	
16	5MV-22184-00	.BUSH	1	1	1	
17	1C3-22253-L1	.COLLAR, DISTANCE	2	2	2	
18	5NY-22475-00	.SEAL, DUST	2	2	2	
19	1C3-22565-00	.SPRING SEAT			2	FOR OCE,ZAF
20	5XE-22242-00	BOLT 2	1	1	1	
21	95602-10200	NUT, U FLANGE	1	1	1	

FIG. 21 STEERING



1C39100-F210

REF. NO.	PART NO.	DESCRIPTION	1S86	1S87	1S88	REMARKS
1	93332-00068	BEARING	1	1	1	
2	4EW-23416-00	COVER, BALL RACE 2	1	1	1	
3	90179-28013	NUT	1	1	1	
4	90201-286K9	WASHER, PLATE (T1.0)	1	1	1	
5	1C3-23435-50	CROWN, HANDLE	1	1	1	
6	90170-24003	NUT	1	1	1	
7	90201-24016	WASHER, PLATE	1	1	1	
8	5XC-23441-90	HOLDER, HANDLE UPPER	2	2	2	
9	5XC-23442-90	HOLDER, HANDLE LOWER	2	2	2	
10	90201-12028	WASHER, PLATE	2	2	2	
11	95602-12200	NUT, SELF-LOCKING	2	2	2	
12	90105-08134	BOLT, FLANGE	8	8	8	
13	1C3-23485-51	PLATE, NUMBER	1	1	1	
14	90119-06146	BOLT, WITH WASHER	1	1	1	

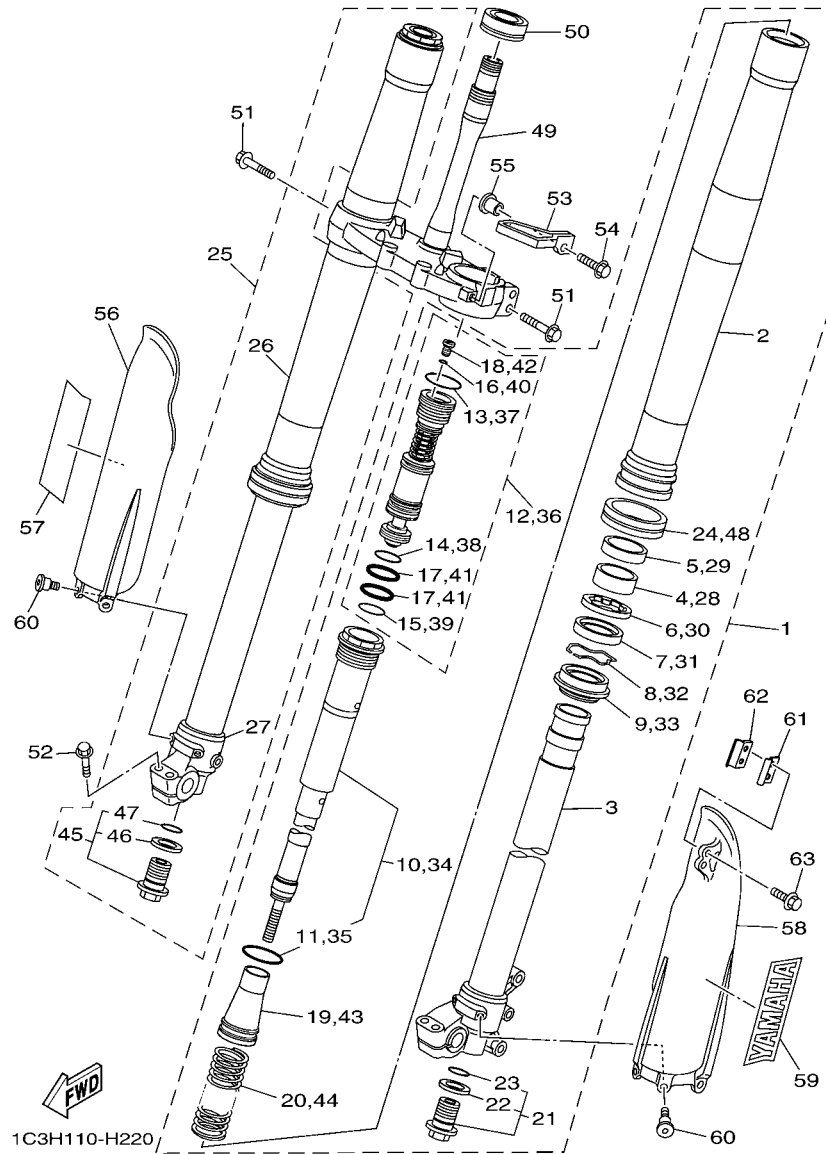

FIG. 22 FRONT FORK

REF. NO.	PART NO.	DESCRIPTION	1S86	1S87	1S88	REMARKS
1	1P8-23102-E0	FRONT FORK ASSY (L.H)	1			
	1P8-23102-D0	FRONT FORK ASSY (L.H)		1	1	
2	1C3-23136-P0	.TUBE, OUTER (RIGHT)	1	1	1	
3	5XC-23120-N0	.INNER TUBE COMP.2	1	1	1	
4	5XE-23171-L0	.PISTON, FRONT FORK	1	1	1	
5	5XE-23125-L0	.METAL, SLIDE 1	1	1	1	
6	5XC-23146-00	.WASHER, OIL SEAL	1	1	1	
7	1C3-23145-M0	.OIL SEAL	1	1	1	
8	5XE-23153-L0	.RING, SNAP	1	1	1	
9	5XE-23144-L0	.SEAL, DUST	1	1	1	
10	5XC-23170-P0	.CYLINDER COMP., FRONT FORK	1	1	1	
11	1C3-23147-L0	..O-RING	1	1	1	
12	1P8-2316A-R0	.VALVE COMP.	1			
	1P8-2316A-P0	.VALVE COMP.		1	1	
13	1C3-23188-L0	..O-RING	1	1	1	
14	1C3-23188-N0	..O-RING	1	1	1	
15	1C3-23188-P0	..O-RING	1	1	1	
16	1C3-23188-R0	..O-RING	1	1	1	
17	1AE-23147-00	..O-RING	2	2	2	
18	1C3-23190-L0	..AIR VALVE COMP.	1	1	1	
19	1C3-23142-L0	.SEAT, SPRING UPPER	1	1	1	
20	5XC-23141-M1	.SPRING, FRONT FORK(K=4.3N/MM)	1	1	1	
21	5XC-23111-00	.BOLT, CAP	1	1	1	
22	2HH-23158-L0	..GASKET	1	1	1	
23	276-23114-00	..GASKET	1	1	1	
24	5XC-2314F-00	.PROTECTOR GUIDE COMP., 1	1	1	1	
25	1P8-23103-E0	FRONT FORK ASSY (R.H)	1			

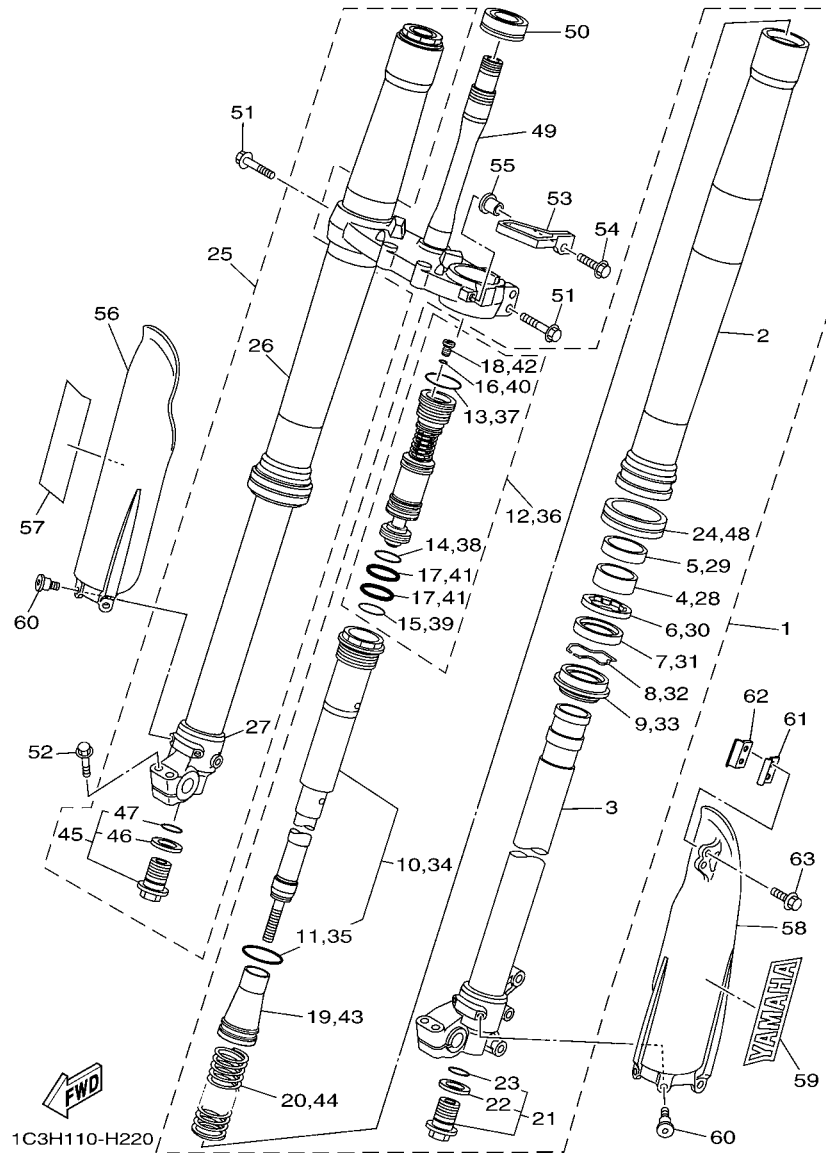

FIG. 22 FRONT FORK

REF. NO.	PART NO.	DESCRIPTION	1S86	1S87	1S88	REMARKS
25	1P8-23103-D0	FRONT FORK ASSY (R.H)	1	1	1	
26	1C3-23136-P0	.TUBE, OUTER (RIGHT)	1	1	1	
27	5XC-23110-N0	.INNER TUBE COMP.1	1	1	1	
28	5XE-23171-L0	.PISTON, FRONT FORK	1	1	1	
29	5XE-23125-L0	.METAL, SLIDE 1	1	1	1	
30	5XC-23146-00	.WASHER, OIL SEAL	1	1	1	
31	1C3-23145-M0	.OIL SEAL	1	1	1	
32	5XE-23153-L0	.RING, SNAP	1	1	1	
33	5XE-23144-L0	.SEAL, DUST	1	1	1	
34	5XC-23170-P0	.CYLINDER COMP., FRONT FORK	1	1	1	
35	1C3-23147-L0	..O-RING	1	1	1	
36	1P8-2316A-R0	.VALVE COMP.	1			
	1P8-2316A-P0	.VALVE COMP.		1	1	
37	1C3-23188-L0	..O-RING	1	1	1	
38	1C3-23188-N0	..O-RING	1	1	1	
39	1C3-23188-P0	..O-RING	1	1	1	
40	1C3-23188-R0	..O-RING	1	1	1	
41	1AE-23147-00	..O-RING	2	2	2	
42	1C3-23190-L0	..AIR VALVE COMP.	1	1	1	
43	1C3-23142-L0	.SEAT, SPRING UPPER	1	1	1	
44	5XC-23141-M1	.SPRING, FRONT FORK(K=4.3N/MM)	1	1	1	
45	5XC-23111-00	.BOLT, CAP	1	1	1	
46	2HH-23158-L0	..GASKET	1	1	1	
47	276-23114-00	..GASKET	1	1	1	
48	5XC-2314F-00	.PROTECTOR GUIDE COMP., 1	1	1	1	
49	1P8-23340-M0	UNDER BRACKET COMP.	1	1	1	
50	93332-00081	BEARING	1	1	1	

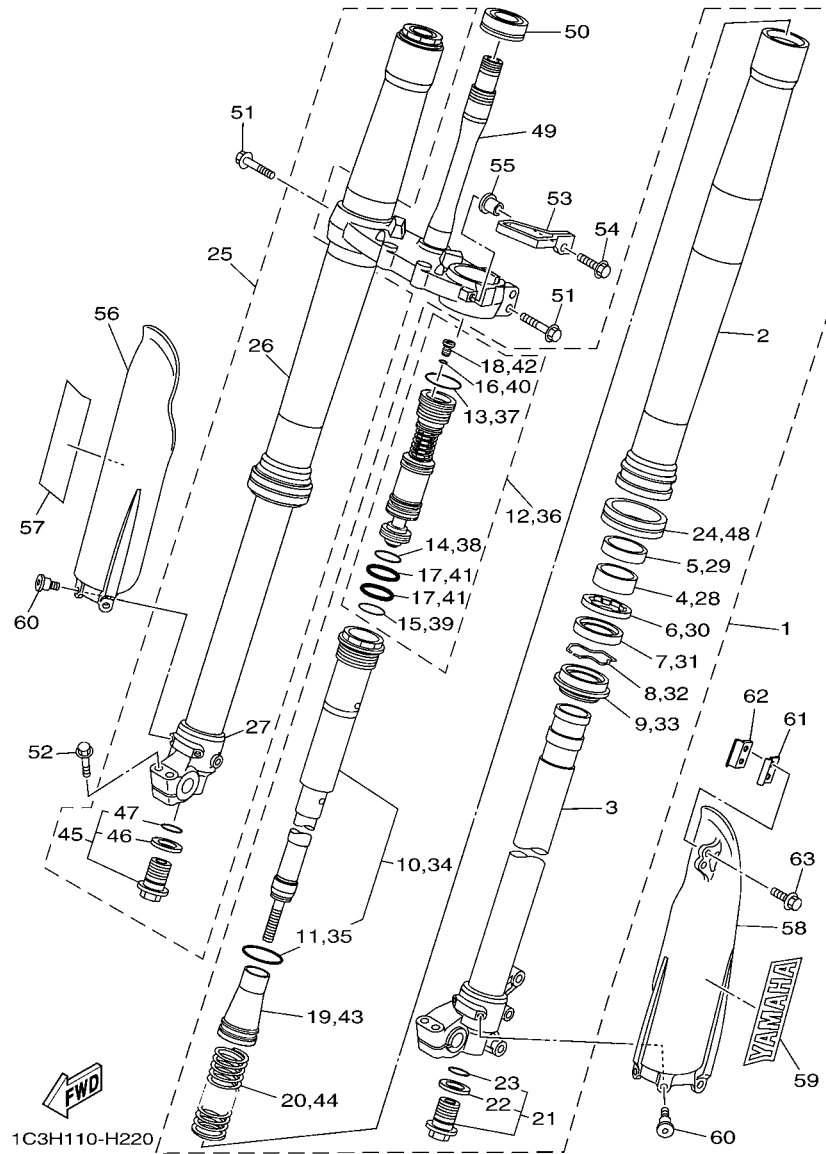
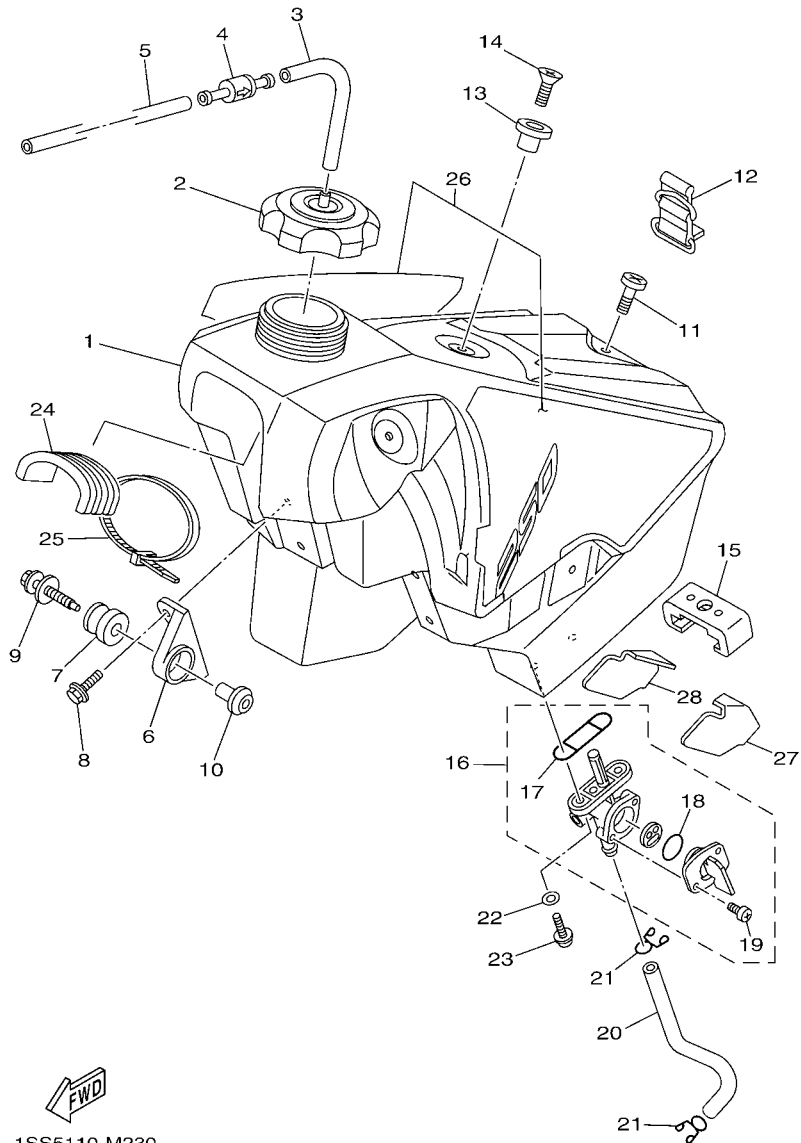

FIG. 22 FRONT FORK

REF. NO.	PART NO.	DESCRIPTION	1S86	1S87	1S88	REMARKS
51	90105-08134	BOLT, FLANGE	4	4	4	
52	90105-08154	BOLT, FLANGE	4	4	4	
53	5XE-23389-00	GUIDE, CABLE	1	1	1	
54	90105-06107	BOLT, FLANGE	1	1	1	
55	90387-06104	COLLAR	1	1	1	
56	5XC-2315J-00	PROTECTOR 2	1	1	1	
57	4XL-2153A-10	EMBLEM, YAMAHA	1	1	1	
58	5XC-2315H-00	PROTECTOR 1	1	1	1	
59	4XL-2153A-10	EMBLEM, YAMAHA	1	1	1	
60	90109-06232	BOLT	6	6	6	
61	17D-23466-00	CLAMP	1	1	1	
62	17D-23467-00	CLAMP	1	1	1	
63	90105-06178	BOLT, FLANGE	2	2	2	



1SS5110-M230

FIG. 23 FUEL TANK

REF. NO.	PART NO.	DESCRIPTION	1SS6	1SS7	1SS8	REMARKS
1	1C3-24110-90	FUEL TANK COMP.	1	1	1	
2	5NY-24610-10	CAP ASSY	1	1	1	
3	90445-09003	HOSE (L30)	1	1	1	
4	3XJ-24380-00	PIPE JOINT ASSY	1	1	1	
5	90445-09005	HOSE	1	1	1	
6	5XE-24144-00	HOLDER, DAMPER	2	2	2	
7	90480-18549	GROMMET	2	2	2	
8	90105-06107	BOLT, FLANGE	4	4	4	
9	5XE-24176-10	BOLT 1	2	2	2	
10	5NY-24186-00	WASHER, SPECIAL	2	2	2	
11	98902-06025	SCREW, BIND	1	1	1	
12	3SP-24173-00	BAND, TANK FITTING 1	1	1	1	
13	4EW-2412F-00	BRACKET, SEAT	1	1	1	
14	98702-06025	SCREW, FLAT HEAD	1	1	1	
15	1C3-24181-00	DAMPER, LOCATING 1	1	1	1	
16	3JD-24500-20	FUEL COCK ASSY 1	1	1	1	
17	4X8-24512-10	.GASKET	1	1	1	
18	3AJ-24534-10	.SEAL, COCK	1	1	1	
19	98502-03008	.SCREW, PAN HEAD	2	2	2	
20	90445-111J0	HOSE (L145)	1	1	1	
21	90467-100A1	CLIP	2	2	2	
22	90202-05193	WASHER, PLATE	2	2	2	
23	90149-06108	SCREW	2	2	2	
24	1P8-24182-00	DAMPER, LOCATING 2	1	1	1	
25	90465-13275	CLAMP	1	1	1	
26	1SS-24240-00	GRAPHIC SET	1	1	1	
27	1C3-24183-00	DAMPER, LOCATING 3	1	1	1	

FIG. 25 FRONT WHEEL

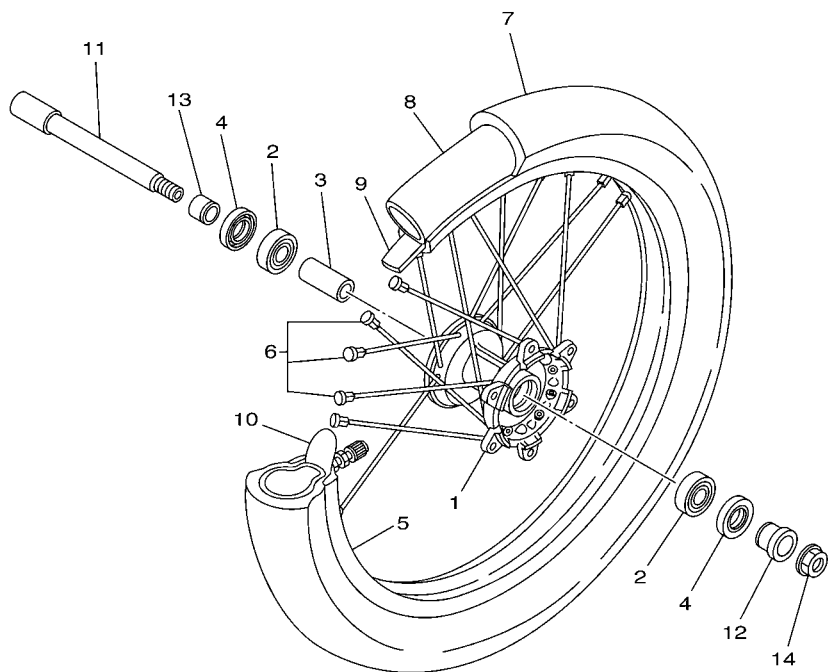

REF. NO.	PART NO.	DESCRIPTION	1S86	1S87	1S88	REMARKS
1	5NY-25111-00	HUB, FRONT	1	1	1	
2	93306-90409	BEARING	2	2	2	
3	5NY-25117-00	SPACER, BEARING	1	1	1	
4	93102-26468	OIL SEAL	2	2	2	
5	94416-21034	RIM (1.60-21)	1	1	1	
6	5NY-25104-00	SPOKE SET, FRONT	1	1	1	
7	94108-2112Y	TIRE (80/100-21 51M D755F)	1			DUNLOP
	94108-21012	TIRE(80/100-21 51M M601)		1		BRIDGESTONE
	94108-21025	TIRE (80/100-21 51M D742FA)			1	DUNLOP
8	94227-21101	TUBE (80/100-21 M/C TR4)	1		1	DUNLOP
	94209-21229	TUBE (80/100-21 M/C TR4)		1		BRIDGESTONE
9	94309-21161	BAND, RIM (22-21)	1		1	DUNLOP
	94330-21084	BAND,RIM (1.60-21)		1		BRIDGESTONE
10	5SF-25394-00	SPACER, BEAD	1	1	1	
11	5XC-25181-G0	AXLE, WHEEL	1	1	1	
12	5XC-25183-G0	COLLAR, WHEEL	1	1	1	
13	5XC-25186-G0	COLLAR, WHEEL	1	1	1	
14	90179-16011	NUT	1	1	1	



1C31100-D250

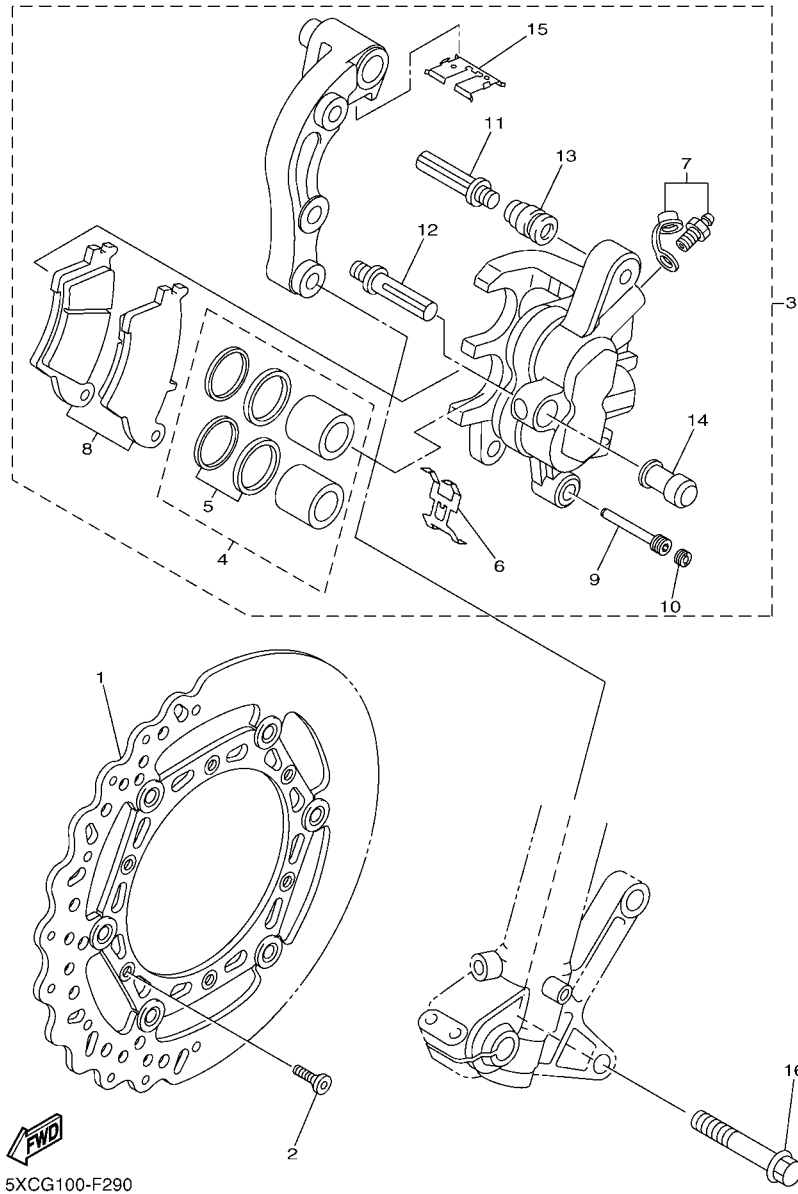

FIG. 26 FRONT BRAKE CALIPER

REF. NO.	PART NO.	DESCRIPTION	1S86	1S87	1S88	REMARKS
1	5XC-2581T-G0	DISK BRAKE ASSY	1	1	1	
2	90151-06051	SCREW, COUNTERSUNK	6	6	6	
3	5XC-2580T-G0	CALIPER ASSY (LEFT)	1	1	1	
4	5XC-W0057-00	.PISTON ASSY, CALIPER	1	1	1	
5	5KM-W0047-10	..CALIPER SEAL KIT	1	1	1	
6	5DH-25919-00	..SUPPORT, PAD	1	1	1	
7	1UY-W0048-50	.BLEED SCREW KIT	1	1	1	
8	5XC-W0045-00	.BRAKE PAD KIT	1	1	1	
9	5DH-25933-00	.PIN, PAD	1	1	1	
10	5DH-25916-00	.PLUG	1	1	1	
11	3SP-25926-51	.BOLT	1	1	1	
12	3SP-25914-51	.PIN, SLIDE	1	1	1	
13	3JD-25917-00	.BOOT, CALIPER	1	1	1	
14	1UY-25937-51	.BOOT 2	1	1	1	
15	5XC-25849-G0	.RETAINER, CALIPER	1	1	1	
16	90105-08137	BOLT, FLANGE	2	2	2	

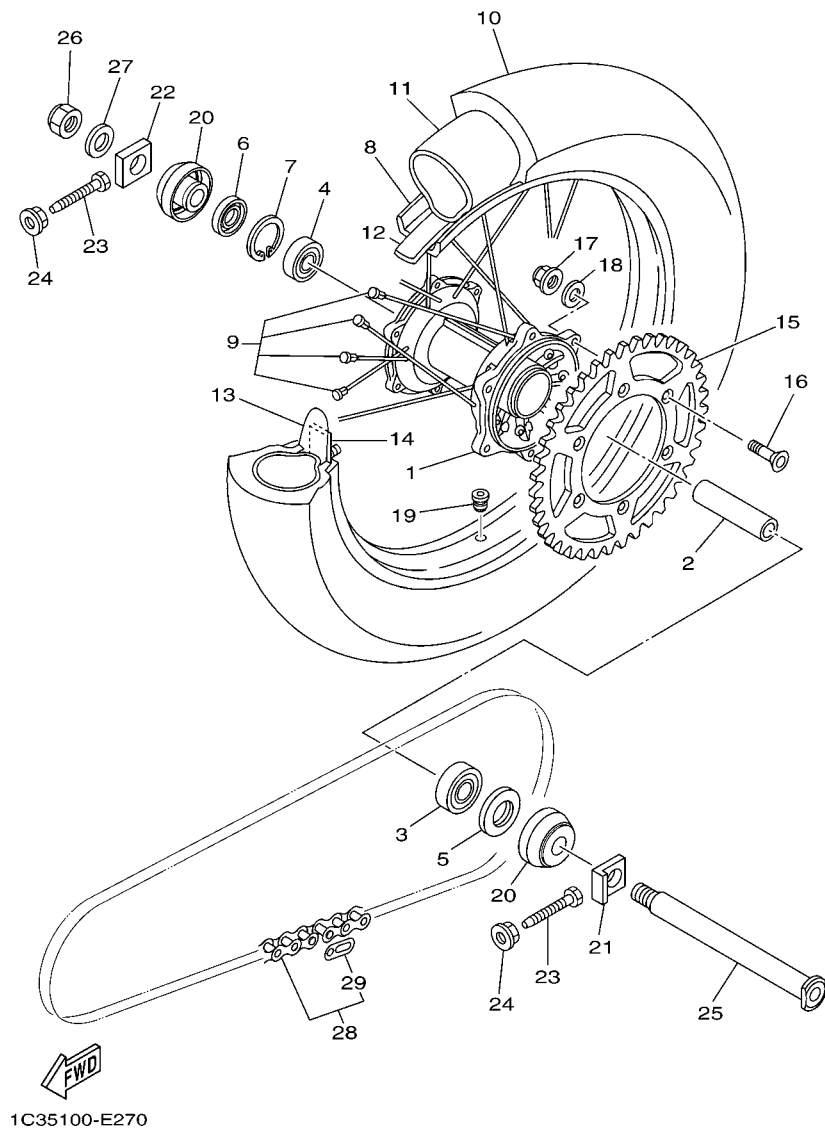
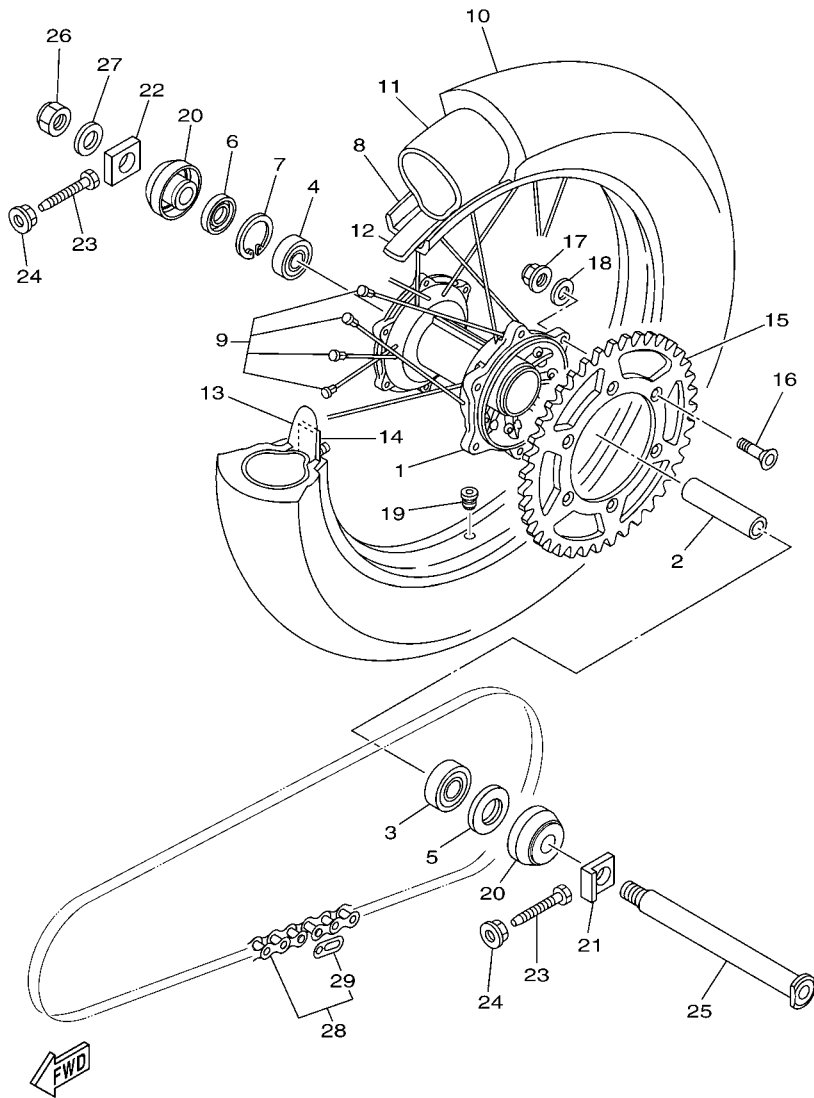

FIG. 27 REAR WHEEL

REF. NO.	PART NO.	DESCRIPTION	1S86	1S87	1S88	REMARKS
1	5ET-25311-00	HUB, REAR	1	1	1	
2	5ET-25317-00	SPACER, BEARING	1	1	1	
3	93306-27212	BEARING	1	1	1	
4	93306-07202	BEARING	1	1	1	
5	93106-30001	OIL SEAL	1	1	1	
6	93106-30045	OIL SEAL	1	1	1	
7	99009-45500	CIRCLIP	1	1	1	
8	94421-19005	RIM (2.15-19)	1	1	1	
9	5HD-25304-00	SPOKE SET, REAR	1	1	1	
10	94111-1913A	TIRE (110/90-19 62M D755)	1			DUNLOP
	94111-19011	TIRE (110/90-19 62M M602)		1		BRIDGESTONE
	94111-19015	TIRE (110/90-19 62M D756)			1	DUNLOP
11	94211-19273	TUBE (110/90-19 M/C TR4)	1	1		DUNLOP
	94211-19274	TUBE (110/90-19 M/C TR4)		1		BRIDGESTONE
12	94311-19155	BAND, RIM (2.5-19)	1	1		DUNLOP
	94321-19157	BAND, RIM (2.15-19)		1		BRIDGESTONE
13	3JE-25394-00	SPACER, BEAD	1	1	1	
14	4XM-25364-00	DAMPER	1	1	1	
15	1C3-25450-00	SPROCKET, DRIVEN (50T)	1	1	1	STD
	1C3-25447-00	SPROCKET, DRIVEN (47T)	1	1	1	AP
	1C3-25448-00	SPROCKET, DRIVEN (48T)	1	1	1	AP
	1C3-25449-00	SPROCKET, DRIVEN (49T)	1	1	1	AP
	1C3-25451-00	SPROCKET, DRIVEN (51T)	1	1	1	AP
	1C3-25452-00	SPROCKET, DRIVEN (52T)	1	1	1	AP
16	90109-08078	BOLT	6	6	6	
17	90185-08008	NUT, SELF-LOCKING	6	6	6	
18	90201-08048	WASHER, PLATE	6	6	6	



1C35100-E270

FIG. 27 REAR WHEEL

REF. NO.	PART NO.	DESCRIPTION	1S86	1S87	1S88	REMARKS
19	90480-08608	GROMMET	1	1	1	
20	5TJ-2530S-80	COLLAR ASSY	2	2	2	
21	1C3-25388-H0	PULLER, CHAIN 1	1	1	1	
22	1C3-25389-H0	PULLER, CHAIN 2	1	1	1	
23	90101-08006	BOLT	2	2	2	
24	90179-08019	NUT	2	2	2	
25	1C3-25381-90	AXLE, WHEEL	1	1	1	
26	90185-20002	NUT, SELF-LOCKING	1	1	1	
27	90201-20020	WASHER, PLATE	1	1	1	
28	9Y582-28113	CHAIN (DID520DMA2-114LL)	1	1	1	
29	94682-28001	JOINT, CHAIN(DID520DM G&B-RJ)	1	1	1	

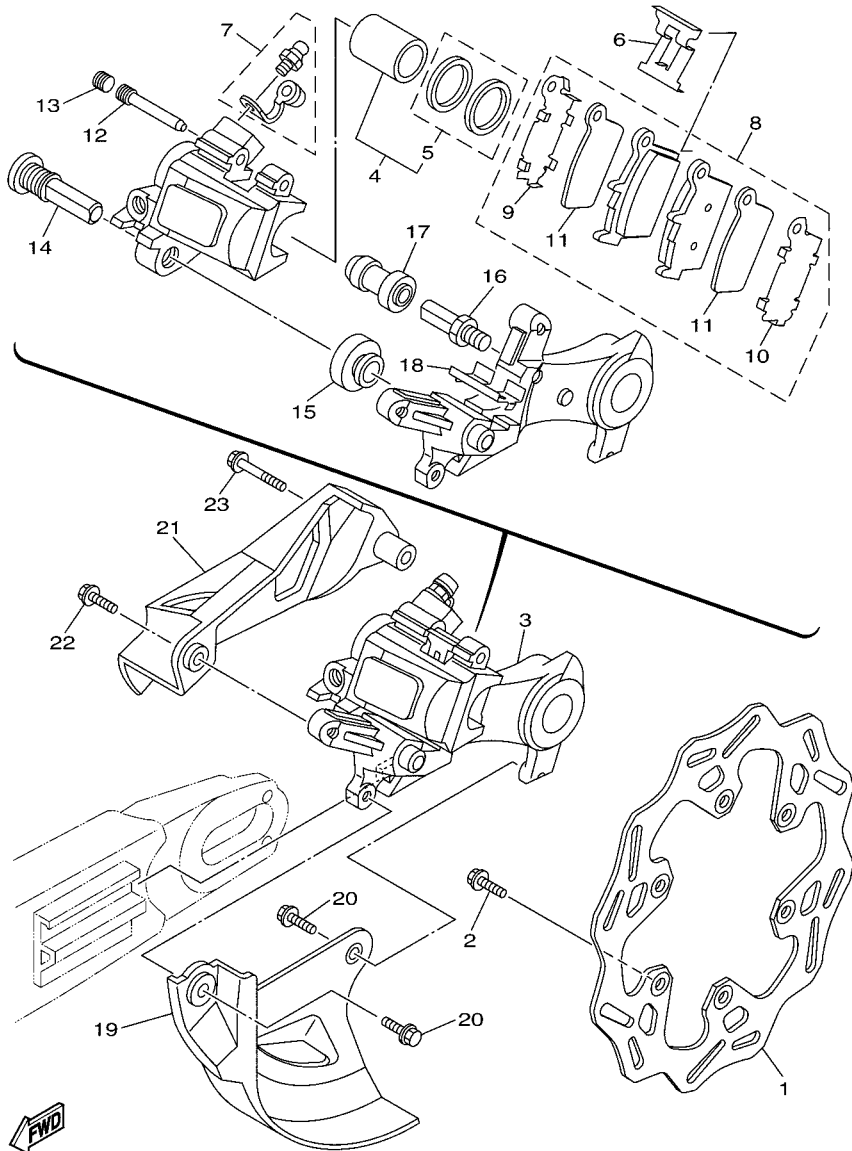

1DX5200-M320

FIG. 28 REAR BRAKE CALIPER

REF. NO.	PART NO.	DESCRIPTION	1S86	1S87	1S88	REMARKS
1	2S2-2582W-70	DISK, REAR BRAKE 2	1	1	1	
2	90105-06108	BOLT, FLANGE	6	6	6	
3	1C3-2580W-62	CALIPER ASSY, REAR 2	1	1	1	
4	5UN-W0057-50	.PISTON ASSY, CALIPER	1	1	1	
5	5UN-W0047-50	..CALIPER SEAL KIT	1	1	1	
6	5DH-25919-50	..SUPPORT, PAD	1	1	1	
7	1UY-W0048-50	..BLEED SCREW KIT	1	1	1	
8	1C3-W0046-10	..BRAKE PAD KIT 2	1	1	1	
9	5UN-25828-60	..SHIM, CALIPER	1	1	1	
10	5UN-25827-60	..SHIM, CALIPER	1	1	1	
11	5UN-22898-60	..INSULATOR, HEAT	2	2	2	
12	8CR-25924-00	..PIN, PAD	1	1	1	
13	5DH-25916-00	..PLUG	1	1	1	
14	5DH-25914-50	..PIN, SLIDE	1	1	1	
15	3JD-25917-00	..BOOT, CALIPER	1	1	1	
16	5UN-25914-00	..PIN, SLIDE	1	1	1	
17	1UY-25937-51	..BOOT 2	1	1	1	
18	5UN-25913-00	..RETAINER	1	1	1	
19	1C3-25718-50	PROTECTOR, DISK BRAKE	1	1	1	
20	90105-06110	BOLT, FLANGE	2	2	2	
21	1C3-27491-50	PROTECTOR	1	1	1	
22	90105-06107	BOLT, FLANGE	1	1	1	
23	90105-06111	BOLT, FLANGE	1	1	1	

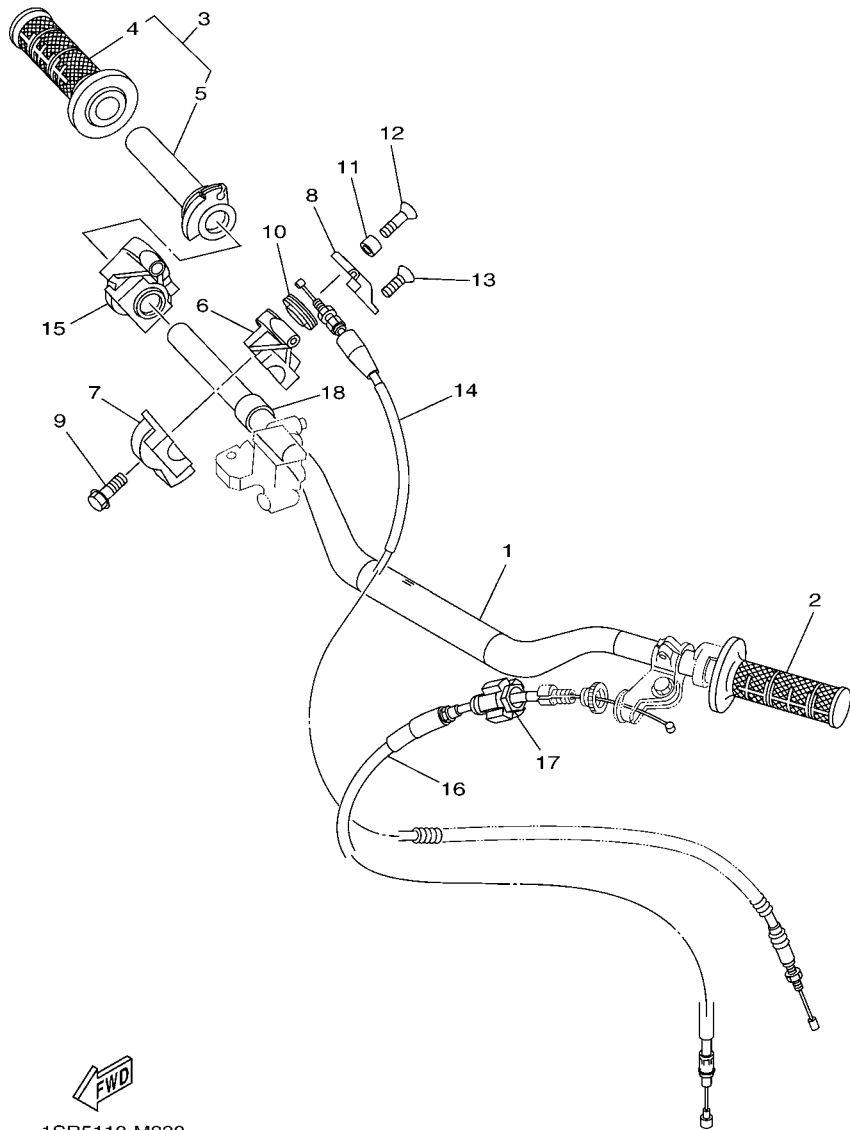

FIG. 29 STEERING HANDLE & CABLE

REF. NO.	PART NO.	DESCRIPTION	1S86	1S87	1S88	REMARKS
1	17D-26111-H0	HANDLEBAR	1	1	1	
2	4GY-26241-00	GRIP	1	1	1	
3	4XM-26240-00	GRIP ASSY	1	1	1	
4	4GY-26242-00	.GRIP (RIGHT)	1	1	1	
5	4XM-26243-00	.TUBE, THROTTLE GUIDE	1	1	1	
6	1C3-26281-90	CAP, GRIP UPPER	1	1	1	
7	1C3-26282-90	CAP, GRIP UNDER	1	1	1	
8	1C3-2628H-90	CAP, WIRE	1	1	1	
9	90105-06112	BOLT, FLANGE	2	2	2	
10	1C3-26273-90	ROTOR	1	1	1	
11	90387-04003	COLLAR	1	1	1	
12	98680-04510	SCREW, OVAL HEAD	1	1	1	
13	98680-04516	SCREW, OVAL HEAD	1	1	1	
14	1P8-26311-90	CABLE, THROTTLE 1	1	1	1	
15	4SS-26287-01	COVER, CAP GRIP	1	1	1	
16	1P8-26335-90	CABLE, CLUTCH	1	1	1	
17	1C3-26342-50	BOOT, CABLE	1	1	1	
18	90387-227H7	COLLAR	1	1	1	

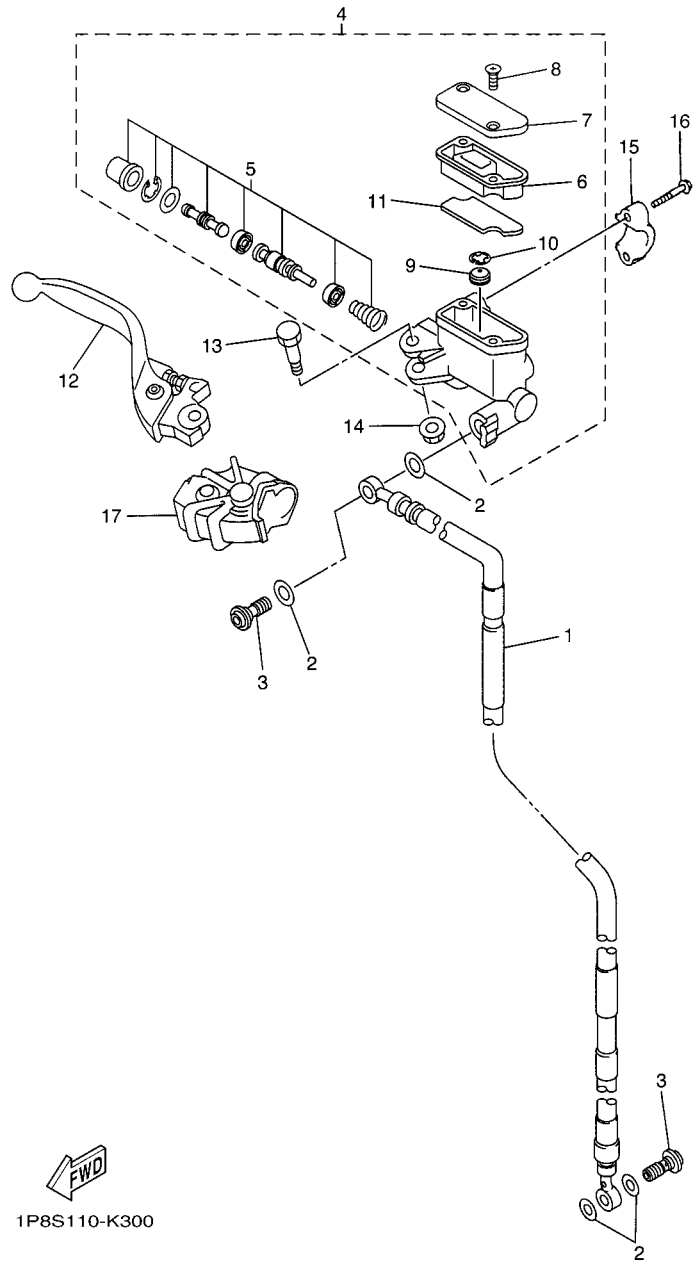

FIG. 30 FRONT MASTER CYLINDER

REF. NO.	PART NO.	DESCRIPTION	1S86	1S87	1S88	REMARKS
1	5XC-25872-L0	HOSE, BRAKE 1	1	1	1	
2	90430-10005	GASKET	4	4	4	
3	90401-10172	BOLT, UNION	2	2	2	
4	5XC-W2587-00	MASTER CYLINDER SUB ASSY	1	1	1	
5	5XC-W0041-00	.CYLINDER KIT, MASTER	1	1	1	
6	5XC-25854-G0	.DIAPHRAGM, RESERVOIR	1	1	1	
7	5XC-25852-G0	.CAP, RESERVOIR	1	1	1	
8	98706-04012	.SCREW, FLAT HEAD	2	2	2	
9	5CG-25715-00	.SEPARATOR ASSY	1	1	1	
10	5CG-2585G-00	.CIRCLIP	1	1	1	
11	5XC-25853-G0	.FLOAT, RESERVOIR	1	1	1	
12	5XC-83922-L0	LEVER 2	1	1	1	
13	5MV-2589F-00	BOLT, LEVER	1	1	1	
14	95701-06500	NUT, WITH WASHER	1	1	1	
15	5MV-25867-00	BRACKET, MASTER CYLINDER	1	1	1	
16	5MV-25833-00	BOLT, FITTING	2	2	2	
17	5XC-26372-G0	COVER, HANDLE LEVER 1	1	1	1	

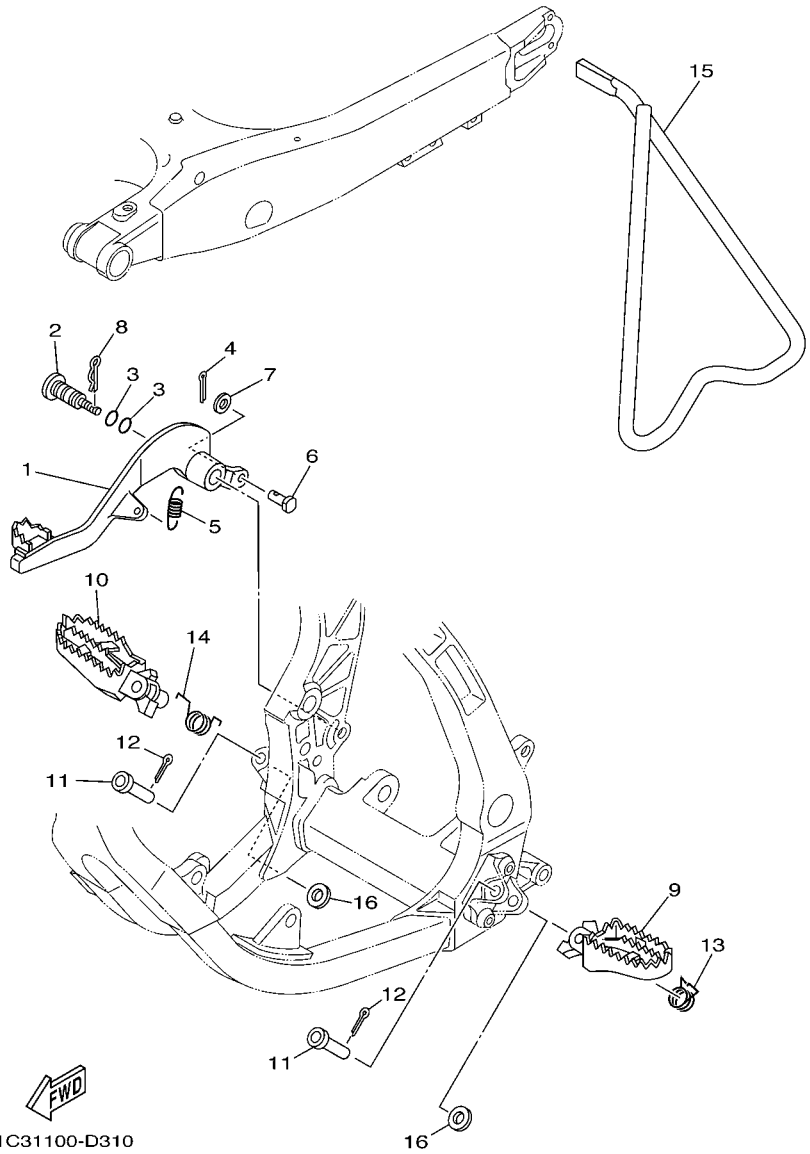
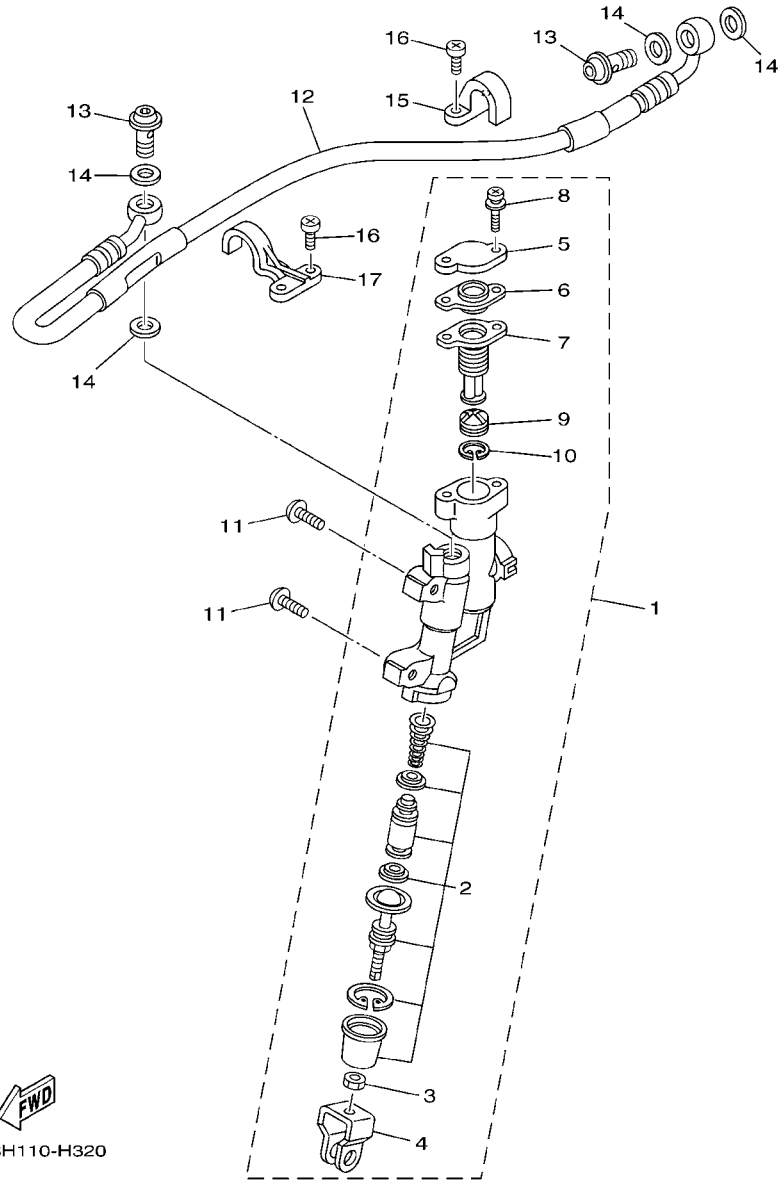

FIG. 31 STAND & FOOTREST

REF. NO.	PART NO.	DESCRIPTION	1S86	1S87	1S88	REMARKS
1	4XM-27200-21	PEDAL, BRAKE	1	1	1	
2	1C3-27217-10	BOLT	1	1	1	
3	93210-11073	O-RING	2	2	2	
4	91402-20012	PIN, COTTER	1	1	1	
5	90506-16007	SPRING, TENSION	1	1	1	
6	90240-08120	PIN, CLEVIS	1	1	1	
7	90201-08044	WASHER, PLATE	1	1	1	
8	90468-16001	CLIP	1	1	1	
9	5XE-27411-02	FOOTREST 1	1	1	1	
10	5XE-27421-02	FOOTREST 2	1	1	1	
11	90240-10004	PIN, CLEVIS	2	2	2	
12	91402-25015	PIN, COTTER	2	2	2	
13	90508-28015	SPRING, TORSION	1	1	1	
14	90508-28018	SPRING, TORSION	1	1	1	
15	1C3-27311-00	STAND, SIDE	1	1	1	
16	90201-10032	WASHER, PLATE	2	2	2	



1C3H110-H320

FIG. 32 REAR MASTER CYLINDER

REF. NO.	PART NO.	DESCRIPTION	1S86	1S87	1S88	REMARKS
1	17D-2583V-00	RR. MASTER CYLINDER ASSY.	1	1	1	
2	5UN-W0042-50	.CYLINDER KIT, MASTER	1	1	1	
3	5UN-27218-00	.NUT	1	1	1	
4	5UN-27222-00	.JOINT	1	1	1	
5	5UN-25852-50	.CAP, RESERVOIR	1	1	1	
6	5UN-2585B-00	.PLATE, DIAPHRAGM	1	1	1	
7	5UN-25854-00	.DIAPHRAGM, RESERVOIR	1	1	1	
8	5UN-27217-00	.BOLT	2	2	2	
9	5CG-25715-00	.SEPARATOR ASSY	1	1	1	
10	5CG-2585G-00	.CIRCLIP	1	1	1	
11	90111-06059	BOLT,HEX. SOCKET BUTTON	2	2	2	
12	5XC-25873-L0	HOSE, BRAKE 2	1	1	1	
13	90401-10172	BOLT, UNION	2	2	2	
14	90430-10005	GASKET	4	4	4	
15	1C3-25886-50	HOLDER, BRAKE HOSE	1	1	1	
16	98502-05010	SCREW, PAN HEAD	4	4	4	
17	1C3-25876-50	HOLDER, BRAKE HOSE 2	1	1	1	

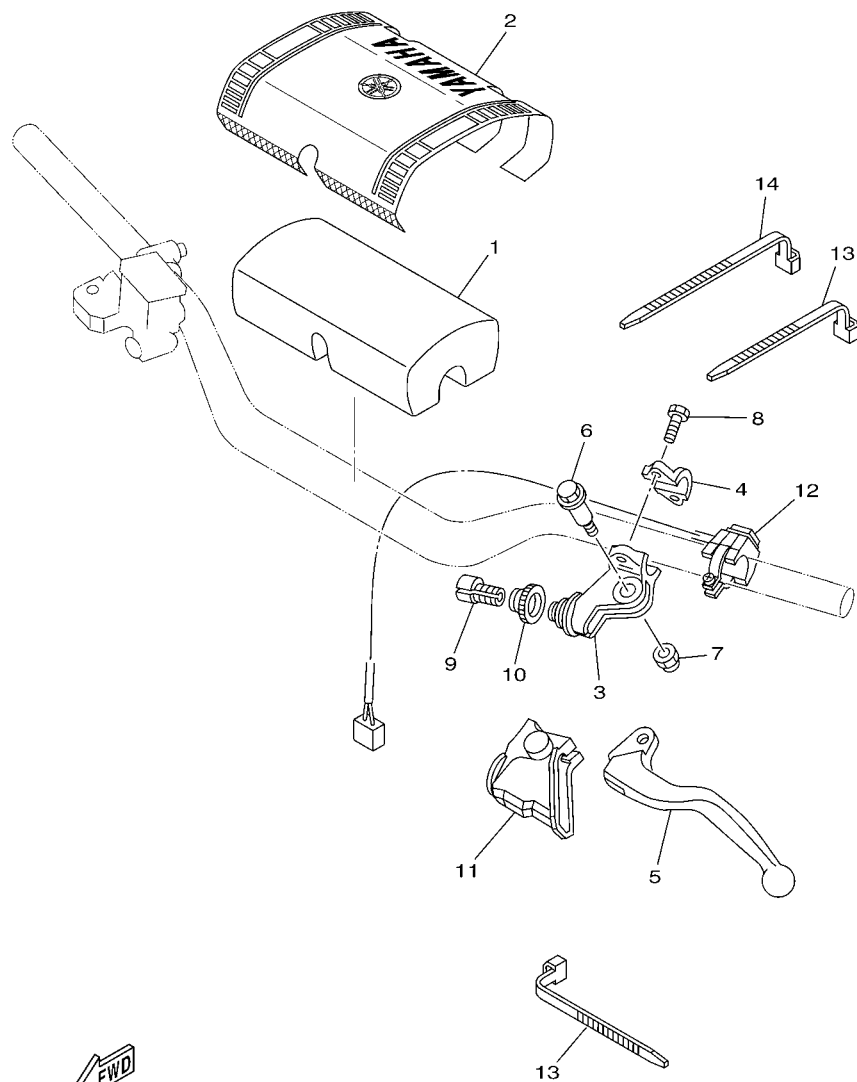

1SR5110-M340

FIG. 34 HANDLE SWITCH & LEVER

REF. NO.	PART NO.	DESCRIPTION	1S86	1S87	1S88	REMARKS
1	5XC-26124-90	PROTECTOR, HANDLEBAR	1	1	1	
2	17D-26143-H0	COVER, HANDLE UPPER 1	1	1	1	
3	5XE-82911-00	HOLDER, LEVER 1	1	1	1	
4	5TG-82913-00	HOLDER, LEVER LOWER 1	1	1	1	
5	5MV-83912-00	LEVER 1	1	1	1	
6	90109-06034	BOLT	1	1	1	
7	5LP-84126-10	NUT, LENS FITTING	1	1	1	
8	90101-05033	BOLT	2	2	2	
9	5HD-26337-00	BOLT, ADJUSTING	1	1	1	
10	5HD-83951-00	BOLT, CABLE ADJUSTING	1	1	1	
11	5HD-26372-00	COVER, HANDLE LEVER 1	1	1	1	
12	1C3-83976-00	SWITCH, HANDLE 1	1	1	1	
13	90464-13077	CLAMP	2	2	2	
14	90464-13073	CLAMP	1	1	1	

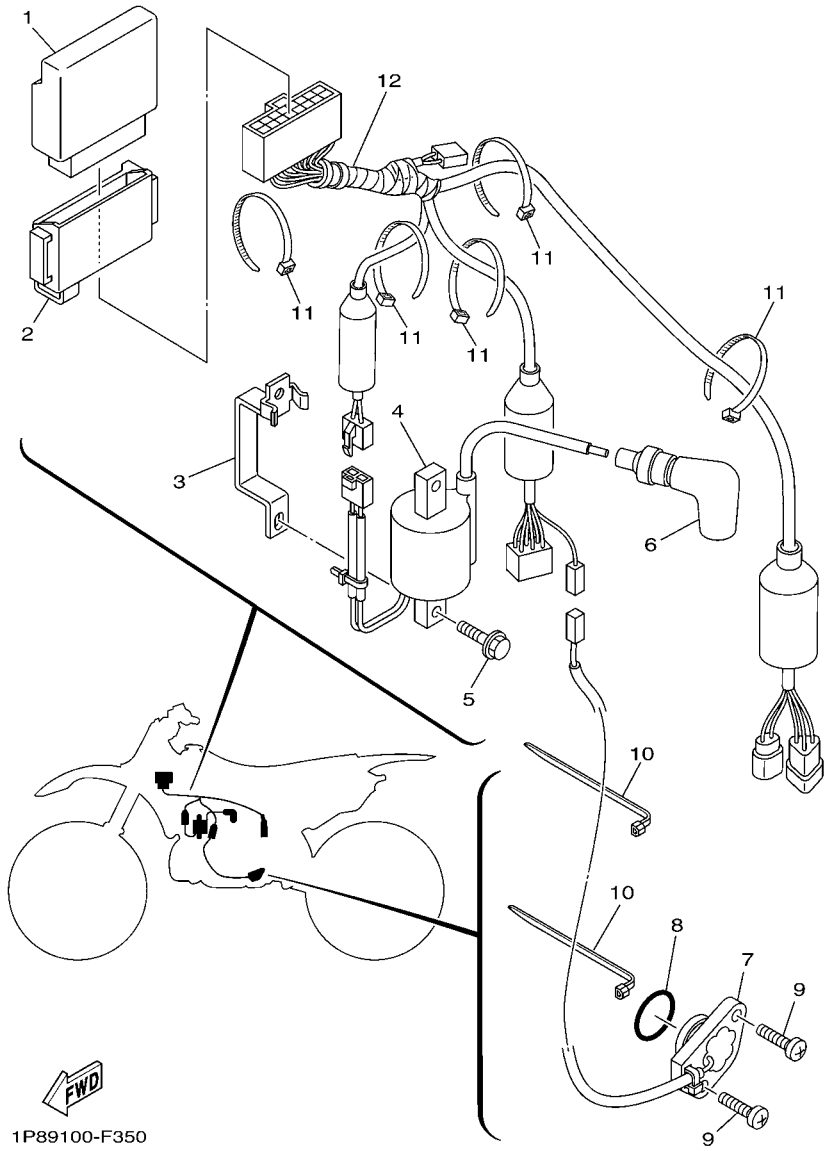
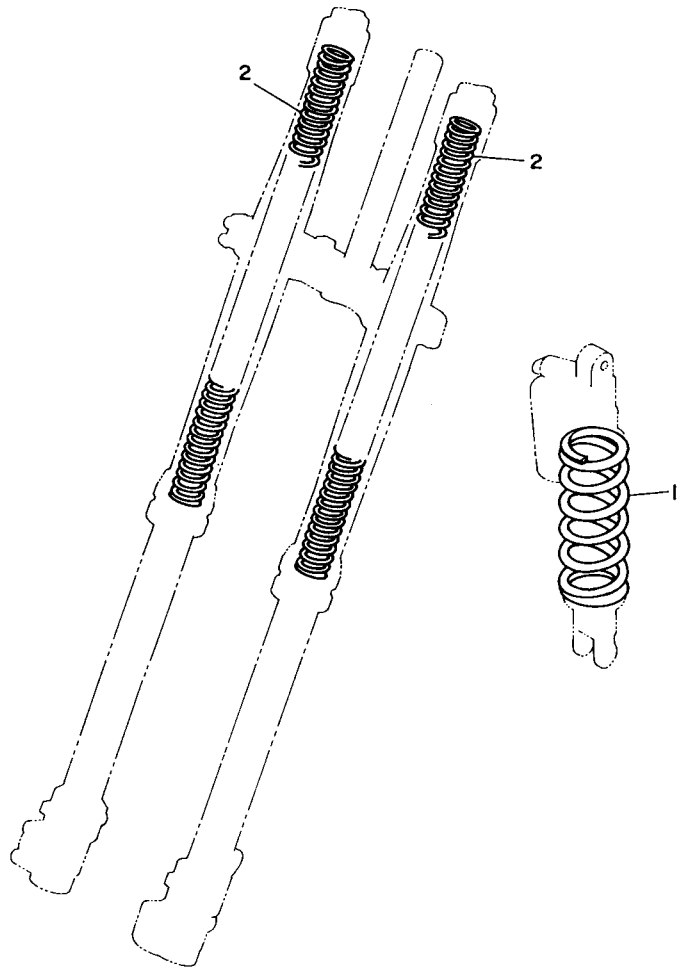

FIG. 35 ELECTRICAL 1

REF. NO.	PART NO.	DESCRIPTION	1S86	1S87	1S88	REMARKS
1	1P8-85540-00	C.D.I. UNIT ASSY	1	1	1	
2	1P8-85546-00	BAND	1	1	1	
3	1P8-8231U-10	CORE, SIDE	1	1	1	
4	1P8-82310-00	IGNITION COIL ASSY	1	1	1	
5	90105-06060	BOLT, FLANGE	2	2	2	
6	8DG-82370-00	PLUG CAP ASSY	1	1	1	
7	1P8-82540-00	NEUTRAL SWITCH ASSY	1	1	1	
8	93210-21001	O-RING	1	1	1	
9	90154-05022	SCREW, BINDING	2	2	2	
10	90464-15195	CLAMP	2	2	2	
11	90465-13275	CLAMP	5	5	5	
12	1P8-82509-20	WIRE, SUB LEAD	1	1	1	



3JD1010-9360

FIG. 36 ALTERNATE FOR CHASSIS

REF. NO.	PART NO.	DESCRIPTION	1S86	1S87	1S88	REMARKS
1	5UN-22212-00	SPRING (K=42N/MM)	1	1	1	AP
	5UN-22212-10	SPRING (K=44N/MM)	1	1		AP
	1C3-22212-00	SPRING (K=44N/MM)			1	AP
	5UN-22212-20	SPRING (K=46N/MM)	1	1		AP
	1C3-22212-10	SPRING (K=46N/MM)			1	AP
	5UN-22212-40	SPRING (K=50N/MM)	1	1		AP
	1C3-22212-30	SPRING (K=50N/MM)			1	AP
	5UN-22212-50	SPRING (K=52N/MM)	1	1	1	AP
	5UN-22212-60	SPRING (K=54N/MM)	1	1	1	AP
	5UN-22212-70	SPRING (K=56N/MM)	1	1	1	AP
	5UN-22212-A0	SPRING (K=APPROX.44N/MM)	1	1	1	AP
	5UN-22212-B0	SPRING (K=APPROX.46N/MM)	1	1	1	AP
	5UN-22212-C0	SPRING (K=APPROX.48N/MM)	1	1	1	AP
	5UN-22212-D0	SPRING (K=APPROX.50N/MM)	1	1	1	AP
	5UN-22212-E0	SPRING (K=APPROX.52N/MM)	1	1	1	AP
	5UN-22212-F0	SPRING (K=APPROX.54N/MM)	1	1	1	AP
	5UN-22212-G0	SPRING (K=APPROX.56N/MM)	1	1	1	AP
2	1C3-23141-A1	SPRING, FRONT FORK(K=3.9N/MM)	2	2	2	AP
	1C3-23141-B1	SPRING, FRONT FORK(K=4.0N/MM)	2	2	2	AP
	1C3-23141-C1	SPRING, FRONT FORK(K=4.1N/MM)	2	2	2	AP
	1C3-23141-D1	SPRING, FRONT FORK(K=4.2N/MM)	2	2	2	AP
	1C3-23141-E1	SPRING, FRONT FORK(K=4.3N/MM)	2	2	2	AP
	1C3-23141-F1	SPRING, FRONT FORK(K=4.4N/MM)	2	2	2	AP
	1C3-23141-G1	SPRING, FRONT FORK(K=4.5N/MM)	2	2	2	AP
	1C3-23141-H1	SPRING, FRONT FORK(K=4.6N/MM)	2	2	2	AP
	1C3-23141-J1	SPRING, FRONT FORK(K=4.7N/MM)	2	2	2	AP

NUMERICAL INDEX

PART NO.	REF. NO.	PART NO.	REF. NO.	PART NO.	REF. NO.	PART NO.	REF. NO.	PART NO.	REF. NO.	PART NO.	REF. NO.
5MW-11111-01	1 - 1	5XF-12428-00	4 - 10	5NX-14453-00	6 - 15	4MX-14943-94	7 - 23	2K7-16154-00	12 - 16	5NX-21425-00	16 - 26
5UP-11311-20	1 - 7	5DJ-12451-00	4 - 2	5NY-14455-20	6 - 17	4MX-14943-95	7 - 23	5CU-16154-00	12 - 13	1C3-21447-10	16 - 3
5XF-1131D-00	1 - 8	5CU-12459-00	4 - 1	3JD-14458-01	6 - 25	4MX-14948-02	7 - 9	2VM-16181-00	12 - 14	1C3-21448-10	16 - 4
5CU-1131E-01	1 - 21	5NX-12461-00	5 - 5	5NY-14459-00	6 - 16	4MX-14948-03	7 - 9	3XK-16321-00	12 - 10	1C3-21511-51	17 - 1
5CU-1131M-10	1 - 43	22W-12462-00	5 - 6	4MX-14948-04	7 - 21	4MX-14948-04	7 - 9	4X7-16325-00	12 - 9	4XL-2153A-10	22 - 57
5CU-1131P-00	1 - 22	1C3-12465-00	5 - 2	4MX-14561-00	7 - 6	4MX-14948-05	7 - 9	5JG-16351-00	12 - 8		22 - 59
5CU-1131U-10	1 - 9		5 - 7	5NX-14562-00	7 - 39	4MX-14948-06	7 - 9	4XL-16356-00	12 - 19	4ES-2153E-20	17 - 15
5CU-1131V-00	1 - 36	5CU-12481-10	5 - 8	1P8-14610-00	8 - 1	4MX-14948-07	7 - 9	1P8-16357-00	12 - 23	5XE-21610-20	17 - 5
5CU-1132A-00	1 - 11	5NY-12482-00	5 - 9	1P8-14610-10	8 - 1		7 - 9	5NX-16371-00	12 - 7	5XE-21635-10	17 - 6
5MW-1132E-00	1 - 32	1P8-12484-00	5 - 10	3JE-14615-01	8 - 15	4MX-14948-08	7 - 9	5CU-16380-10	12 - 24	5TA-21642-00	17 - 11
5MW-1132F-00	1 - 33	353-13115-01	1 - 44	5MW-14642-00	8 - 2		7 - 9	5JG-17121-10	13 - 9	3RV-21668-A0	19 - 36
5UP-11351-00	1 - 12		9 - 8	1P8-1469A-00	8 - 18	4MX-14948-09	7 - 9	5CU-17131-01	13 - 6	5NY-21711-00	18 - 1
5CU-11354-00	1 - 45	5NX-13565-00	6 - 9	1P8-1469E-00	8 - 19	4MX-14948-10	7 - 9	5BE-17141-30	13 - 7	5GJ-21717-00	16 - 9
5NX-11395-00	1 - 29	5NX-13610-10	6 - 1	1P8-14753-00	8 - 16	4MX-14948-11	7 - 9	5BE-17151-00	13 - 3	1C3-21721-50	18 - 4
5UP-11400-10	3 - 6	5NX-13613-00	6 - 2	5CU-14771-01	8 - 4	4MX-14948-12	7 - 9	5BE-17211-00	13 - 14	5NL-2172A-20	18 - 19
5UP-11410-10	3 - 7	4XL-13616-10	6 - 3	5XF-14781-00	8 - 8	4JT-1494F-03	7 - 27	5JG-17221-10	13 - 23	5XE-21730-00	18 - 9
5MW-11420-10	3 - 8	5XF-13622-00	6 - 8	4JT-14916-9G	7 - 10	4JT-1494F-07	7 - 27	5BE-17231-00	13 - 18	1SR-2173E-10	18 - 12
5CU-11603-10	3 - 2	5NX-13624-00	6 - 7	4JT-14916-9H	7 - 10	4JT-1494F-09	7 - 27	5JG-17241-00	13 - 20	1SS-2173F-10	18 - 16
	37 - 3	4XL-13625-00	6 - 6	4JT-14916-9J	7 - 10	4JT-1494F-11	7 - 27	5BE-17251-10	13 - 15	5XE-21740-00	18 - 13
1P8-11630-00	37 - 1	1P8-14101-40	7 - 1	4JT-14916-9W	7 - 10	4JT-1494F-13	7 - 27	5BE-17402-00	13 - 13	5BE-21749-00	18 - 3
1P8-11631-00-A0	3 - 1	1P8-14101-50	7 - 1	4SR-14916-CG	7 - 10	4JT-1494F-15	7 - 27	5BE-17411-00	13 - 1		18 - 6
1P8-11631-00-B0	3 - 1	4SR-14105-00	7 - 15	4SR-14916-CH	7 - 10	4JT-14984-00	7 - 4	5HC-17466-00	10 - 6	5TA-21749-00	18 - 11
	37 - 2	4XL-1410E-00	7 - 26	4SR-14916-CJ	7 - 10	4SR-14985-00	7 - 3	4L0-17471-00	9 - 13		18 - 15
1P8-11631-00-C0	3 - 1	5NX-1410H-10	7 - 30	4SR-14916-CK	7 - 10	1P8-15111-00-YX	9 - 1	5CU-18101-10	15 - 1	1C3-22110-90	19 - 1
1P8-11631-00-D0	3 - 1	4MX-14115-00	7 - 5	4SR-14916-CW	7 - 10	4V4-15118-00	9 - 15	1C3-18110-00	15 - 6	1C3-22121-00	19 - 30
5UP-11633-00	3 - 3	5HC-14126-00	7 - 14	4SR-14916-EG	7 - 10	5CU-15118-10	9 - 16	5MW-18122-01	15 - 2	1C3-22122-00	19 - 31
	37 - 4	5HC-14131-00	7 - 16	4SR-14916-EH	7 - 10	5NX-15121-00-YX	9 - 2	4BR-18127-10	14 - 14	2S2-22128-70	19 - 13
5MW-11650-00	37 - 6	3TJ-14137-40	7 - 22	4SR-14916-EJ	7 - 10	3Y1-15363-10	10 - 18	5CU-18140-01	14 - 7	1C3-22141-10	19 - 17
5MW-11651-00	3 - 10	4XL-14146-00	7 - 8	4SR-14916-EK	7 - 10	4JT-15381-01	9 - 6	5CU-18172-00	15 - 14	2S2-22151-70	19 - 10
	37 - 7	5HC-14146-00	7 - 28	4SR-14916-EW	7 - 10	5CU-15411-10	10 - 1	3XJ-18173-10	15 - 9	5UN-22176-00	20 - 15
5CU-11681-00	3 - 9	4JT-14147-00	7 - 31	4SR-14916-RH	7 - 10	5MW-15415-20	10 - 14	3XJ-18178-00	15 - 10	30X-22178-00	16 - 12
	37 - 8	663-14159-00	7 - 17	4SR-14916-RJ	7 - 10	1P8-15421-10	10 - 5	3XJ-18182-00	15 - 11	3JD-22178-20	16 - 17
5CU-11830-00	1 - 26	4JT-14171-00	7 - 2	4SR-14916-RW	7 - 10	5NX-15431-00	10 - 9	3XJ-18184-00	15 - 13	1C3-2217A-00	19 - 20
4SS-11832-00	1 - 30	4MX-14194-00	7 - 24	4MX-14919-00	7 - 11	5CU-15451-00	10 - 2	4EW-18185-00	14 - 5	1C3-2217F-50	19 - 26
5CU-11911-00	2 - 20	4XL-14196-10	7 - 20	5HC-14922-00	7 - 34	5CU-15454-00	9 - 10	5BE-18501-20	14 - 11	4V4-22184-00	16 - 13
5CU-11912-00	2 - 19	4XL-14197-10	7 - 19	5HC-14934-00	7 - 35	5CU-15462-00	10 - 10	5BE-18502-20	14 - 12	5MV-22184-00	20 - 16
4JY-11915-10	2 - 1	1P8-14208-00	7 - 36	4MX-14943-40	7 - 23	5CU-15463-00	10 - 15	5CU-18503-20	14 - 13	2S2-22199-70	19 - 12
5X4-11921-02	2 - 12	5HC-14216-00	7 - 37	4MX-14943-41	7 - 23	5NX-15601-10	11 - 1	1P8-18541-00	14 - 1	1SS-22200-20	20 - 1
3JE-11922-01	2 - 8	5NX-14216-00	7 - 40	4MX-14943-42	7 - 23	5NX-15620-20	11 - 18	4UN-18542-00	14 - 15	1SS-22200-30	20 - 1
5CU-11952-00	2 - 15	5HC-14261-00	7 - 13	4MX-14943-43	7 - 23	5NX-15621-10	11 - 19	5DH-18562-00	14 - 3	1P8-22200-J1	20 - 1
5NY-11953-00	2 - 13	5HC-14264-00	7 - 32		7 - 23	5CU-15651-00	11 - 14	1P8-21101-50	16 - 1	1P8-22201-G0	20 - 2
5CU-11956-00	12 - 3	5HC-14275-00	7 - 33	4MX-14943-44	7 - 23	5NL-15664-00	11 - 8	5PA-2118K-00	17 - 16	1P8-22201-H0	20 - 2
5CU-11990-10	2 - 7	5HC-14340-A7	7 - 12	4MX-14943-45	7 - 23	4GY-15671-00	11 - 4	5PA-2118K-20	17 - 16	1P8-22201-J0	20 - 2
5CU-11991-00	1 - 38	4MX-14392-00	7 - 7	4MX-14943-90	7 - 23	214-15674-00	11 - 11	1C3-21190-90	16 - 8	1C3-22212-00	36 - 1
5CU-11993-00	1 - 39	5NY-14401-01	6 - 14	4MX-14943-91	7 - 23	214-15686-00	11 - 12	1C3-21244-10	16 - 36	5UN-22212-00	36 - 1
5CU-11995-00	1 - 42	5NY-14417-00	6 - 19	4MX-14943-92	7 - 23	5DJ-16111-00	12 - 1	1C3-21336-00	16 - 2	1C3-22212-10	36 - 1
5NX-1240A-00	5 - 1	5NY-14442-00	6 - 18	4MX-14943-93	7 - 23	5MW-16113-00	12 - 2	1C3-2135F-00	19 - 34	5UN-22212-10	36 - 1
5MW-12422-00	4 - 9	4XM-14451-00	6 - 22		7 - 23	5DJ-16150-00	12 - 6	1C3-2139R-00	19 - 35	1C3-22212-20	20 - 9

NUMERICAL INDEX

PART NO.	REF. NO.	PART NO.	REF. NO.	PART NO.	REF. NO.	PART NO.	REF. NO.	PART NO.	REF. NO.	PART NO.	REF. NO.
5UN-22212-20	36 - 1	1C3-23141-C1	36 - 2	1C3-23190-L0	22 - 42	1C3-25449-00	27 - 15	4XM-26240-00	29 - 3	5UN-W0047-50	28 - 5
1C3-22212-30	36 - 1	1C3-23141-D1	36 - 2	1P8-23340-M0	22 - 49	1C3-25450-00	27 - 15	4GY-26241-00	29 - 2	1UY-W0048-50	26 - 7
5UN-22212-30	20 - 9	1C3-23141-E1	36 - 2	5XE-23389-00	22 - 53	1C3-25451-00	27 - 15	4GY-26242-00	29 - 4		28 - 7
5UN-22212-40	36 - 1	1C3-23141-F1	36 - 2	4EW-23416-00	21 - 2	1C3-25452-00	27 - 15	4XM-26243-00	29 - 5	5XC-W0057-00	26 - 4
5UN-22212-50	36 - 1	1C3-23141-G1	36 - 2	1C3-23435-50	21 - 5	5CG-25715-00	30 - 9	1C3-26273-90	29 - 10	5UN-W0057-50	28 - 4
5UN-22212-60	36 - 1	1C3-23141-H1	36 - 2	5XC-23441-90	21 - 8		32 - 9	1C3-26281-90	29 - 6	5XC-W2587-00	30 - 4
5UN-22212-70	36 - 1	1C3-23141-J1	36 - 2	5XC-23442-90	21 - 9	1C3-25718-50	28 - 19	1C3-26282-90	29 - 7	90101-05033	34 - 8
5UN-22212-A0	36 - 1	5XC-23141-M1	22 - 20	17D-23466-00	22 - 61	5XC-2580T-G0	26 - 3	4SS-26287-01	29 - 15	90101-06041	15 - 15
5UN-22212-B0	36 - 1		22 - 44	17D-23467-00	22 - 62	1C3-2580W-62	28 - 3	1C3-2628H-90	29 - 8	90101-08006	27 - 23
5UN-22212-C0	36 - 1	1C3-23142-L0	22 - 19	1C3-23485-51	21 - 13	5XC-2581T-G0	26 - 1	1P8-26311-90	29 - 14	90105-05014	2 - 3
5UN-22212-D0	36 - 1		22 - 43	1C3-24110-90	23 - 1	5UN-25827-60	28 - 10	1P8-26335-90	29 - 16	90105-06060	35 - 5
5UN-22212-E0	36 - 1	5XE-23144-L0	22 - 9	4EW-2412F-00	23 - 13	5UN-25828-60	28 - 9	5HD-26337-00	34 - 9	90105-06064	18 - 17
5UN-22212-F0	36 - 1		22 - 33	5XE-24144-00	23 - 6	2S2-2582W-70	28 - 1	1C3-26342-50	29 - 17	90105-06081	14 - 4
5UN-22212-G0	36 - 1	1C3-23145-M0	22 - 7	3XJ-2415E-C1	17 - 4	5MV-25833-00	30 - 16	5HD-26372-00	34 - 11	90105-06085	9 - 17
1C3-22213-L0	20 - 7		22 - 31	3SP-24173-00	23 - 12	17D-2583V-00	32 - 1	5XC-26372-G0	30 - 17	90105-06099	17 - 7
1C3-22214-50	20 - 10	5XC-23146-00	22 - 6	5XE-24176-10	23 - 9	5XC-25849-00	26 - 15	4XM-27200-21	31 - 1	90105-06101	17 - 9
5MV-22224-00	20 - 11		22 - 30	1C3-24181-00	23 - 15	5UN-25852-50	32 - 8	5UN-27217-00	32 - 8	90105-06103	18 - 7
4JX-22226-00	20 - 4	1AE-23147-00	22 - 17	1P8-24182-00	23 - 24	5XC-25852-G0	30 - 7	1C3-27217-10	31 - 2	90105-06104	19 - 14
3SP-22234-00	20 - 6		22 - 41	1C3-24183-00	23 - 27	5XC-25853-G0	30 - 11	5UN-27218-00	32 - 3	90105-06105	19 - 16
5NY-22241-00	20 - 23	1C3-23147-L0	22 - 11	1C3-24184-00	23 - 28	5UN-25854-00	32 - 7	5UN-27222-00	32 - 4	90105-06107	22 - 54
5XE-22242-00	20 - 20		22 - 35	5NY-24186-00	23 - 10	5XC-25854-G0	30 - 6	1C3-27311-00	31 - 15		23 - 8
1C3-22253-50	20 - 12	5XC-2314F-00	22 - 24	1SS-24240-00	23 - 26	5UN-2585B-00	32 - 6	5XE-27411-02	31 - 9		28 - 22
1C3-22253-L1	20 - 17		22 - 48	3XJ-24380-00	23 - 4	5CG-2585G-00	30 - 10	5XE-27421-02	31 - 10	90105-06108	28 - 2
4AA-22259-40	20 - 8	5XE-23153-L0	22 - 8	3JD-24500-20	23 - 16		32 - 10	1C3-27491-50	28 - 21	90105-06110	28 - 20
4AA-22259-50	20 - 8		22 - 32	4X8-24512-10	23 - 17	5MV-25867-00	30 - 15	5ET-28166-10	16 - 37	90105-06111	5 - 15
1P8-22355-00	19 - 3	2HH-23158-L0	22 - 22	3AJ-24534-10	23 - 18	5XC-25872-L0	30 - 1	5PG-2816R-00	17 - 16		28 - 23
4EW-22474-00	20 - 14		22 - 46	5NY-24610-10	23 - 2	5XC-25873-L0	32 - 12	1P8-82310-00	35 - 4	90105-06112	29 - 9
3JE-22475-00	20 - 13	5XC-2315H-00	22 - 58	1C3-2470F-H0	24 - 2	1C3-25876-50	32 - 17	1P8-8231U-10	35 - 3	90105-06118	5 - 17
5NY-22475-00	20 - 18	5XC-2315J-00	22 - 56	5NY-24728-10	24 - 3	1C3-25886-50	32 - 15	8DG-82370-00	35 - 6	90105-06178	22 - 63
1C3-22565-00	20 - 19	1P8-2316A-P0	22 - 12	1C3-24770-H1	24 - 1	5MV-2589F-00	30 - 13	1P8-82509-20	35 - 12	90105-08085	16 - 10
5UN-22898-60	28 - 11		22 - 36	5NY-25104-00	25 - 6	5UN-25913-00	28 - 18	1P8-82540-00	35 - 7	90105-08131	16 - 27
1C3-22969-90	19 - 11	1P8-2316A-R0	22 - 12	5NY-25111-00	25 - 1	5UN-25914-00	28 - 16	5XE-82911-00	34 - 3	90105-08132	16 - 11
1P8-23102-D0	22 - 1		22 - 36	5NY-25117-00	25 - 3	5DH-25914-50	28 - 14	5TG-82913-00	34 - 4	90105-08133	16 - 20
1P8-23102-E0	22 - 1	5XC-23170-P0	22 - 10	5XC-25181-G0	25 - 11	3SP-25914-51	26 - 12	5MV-83912-00	34 - 5	90105-08134	21 - 12
1P8-23103-D0	22 - 25		22 - 34	5XC-25183-G0	25 - 12	5DH-25916-00	26 - 10	5XC-83922-L0	30 - 12		22 - 51
1P8-23103-E0	22 - 25	5XE-23171-L0	22 - 4	5XC-25186-G0	25 - 13		28 - 13	5HD-83951-00	34 - 10	90105-08136	8 - 13
5XC-23110-N0	22 - 27		22 - 28	5HD-25304-00	27 - 9	3JD-25917-00	26 - 13	1C3-83976-00	34 - 12	90105-08137	26 - 16
5XC-23111-00	22 - 21	5DH-23183-00	20 - 5	5TJ-2530S-80	27 - 20		28 - 15	5LP-84126-10	34 - 7	90105-08154	22 - 52
	22 - 45	509-23184-L0	20 - 3	5ET-25311-00	27 - 1	5DH-25919-00	26 - 6	1P8-85540-00	35 - 1	90105-10172	16 - 23
276-23114-00	22 - 23	1C3-23188-L0	22 - 13	5ET-25317-00	27 - 2	5DH-25919-50	28 - 6	1P8-85546-00	35 - 2	90105-10173	16 - 30
	22 - 47		22 - 37	4XM-25364-00	27 - 14	8CR-25924-00	28 - 12	5UP-85550-01	33 - 2	90105-10174	16 - 33
5XC-23120-N0	22 - 3	1C3-23188-N0	22 - 14	1C3-25381-90	27 - 25	3SP-25926-51	26 - 11	5CU-85560-20	33 - 1	90105-10445	12 - 5
5XE-23125-L0	22 - 5		22 - 38	1C3-25388-H0	27 - 21	5DH-25933-00	26 - 9	5NX-85885-10	7 - 38	90109-05001	1 - 10
	22 - 29	1C3-23188-P0	22 - 15	1C3-25389-H0	27 - 22	1UY-25937-51	26 - 14	5XC-W0041-00	30 - 5	90109-05009	12 - 27
1C3-23136-P0	22 - 2		22 - 39	3JE-25394-00	27 - 13		28 - 17	5UN-W0042-50	32 - 2	90109-06034	34 - 6
	22 - 26	1C3-23188-R0	22 - 16	5SF-25394-00	25 - 10	17D-26111-H0	29 - 1	5XC-W0045-00	26 - 8	90109-06198	14 - 10
1C3-23141-A1	36 - 2		22 - 40	1C3-25447-00	27 - 15	5XC-26124-90	34 - 1	1C3-W0046-10	28 - 8	90109-06232	22 - 60
1C3-23141-B1	36 - 2	1C3-23190-L0	22 - 18	1C3-25448-00	27 - 15	17D-26143-H0	34 - 2	5KM-W0047-10	26 - 5	90109-06245	6 - 27

NUMERICAL INDEX

PART NO.	REF. NO.	PART NO.	REF. NO.	PART NO.	REF. NO.	PART NO.	REF. NO.	PART NO.	REF. NO.	PART NO.	REF. NO.
90109-08078	27 - 16	90201-06013	14 - 9	90267-32070	6 - 20	90464-06214	6 - 11	92902-10200	16 - 25	93310-52406	3 - 11
90110-08052	11 - 24	90201-06032	17 - 8	90280-03045	3 - 15	90464-13073	34 - 14		16 - 32		37 - 10
90111-06059	32 - 11	90201-06033	8 - 7	90340-12006	9 - 18	90464-13077	34 - 13		16 - 35	93315-11206	12 - 25
90116-08027	1 - 3		17 - 10	90387-04003	29 - 11	90464-15195	35 - 10		20 - 22	93315-32166	19 - 21
90116-10034	1 - 13	90201-06086	8 - 25	90387-06009	17 - 13	90465-13275	23 - 25	92904-05600	16 - 7		19 - 27
	1 - 15	90201-06571	5 - 16		18 - 2		35 - 11	93102-12106	4 - 5	93317-22262	19 - 4
90119-06133	8 - 9	90201-08043	16 - 22		18 - 5	90467-090A2	5 - 4	93102-12224	12 - 26	93332-00068	21 - 1
	8 - 10	90201-08044	31 - 7		18 - 10	90467-100A1	23 - 21		15 - 8	93332-00081	22 - 50
90119-06146	21 - 14	90201-08045	16 - 14		18 - 14	90468-16001	31 - 8	93102-18278	11 - 17	93340-21505	2 - 18
90119-06147	17 - 3	90201-08048	11 - 25	90387-06039	8 - 23	90480-08608	27 - 19	93102-20485	3 - 14		12 - 20
90119-06149	17 - 12		27 - 18	90387-06065	5 - 14	90480-15528	5 - 13	93102-26468	25 - 4	93342-22217	19 - 5
90119-08095	18 - 8	90201-08049	8 - 14	90387-06090	17 - 2	90480-16404	8 - 22	93102-28004	3 - 17	93410-20038	11 - 3
90122-06005	6 - 24	90201-08055	16 - 29	90387-06104	22 - 55	90480-16561	8 - 5	93102-32337	13 - 25	93440-10085	12 - 22
90149-06074	9 - 7	90201-080L8	1 - 6	90387-06121	8 - 21	90480-17004	8 - 20	93104-08040	1 - 28	93440-25084	13 - 5
90149-06108	23 - 23	90201-081G0	1 - 34	90387-063G3	8 - 6	90480-18549	23 - 7		2 - 6		13 - 16
	33 - 3	90201-08512	4 - 3	90387-08030	8 - 12	90501-046L6	1 - 35	93106-22002	19 - 6	93440-28062	13 - 21
90149-10031	16 - 5	90201-08784	4 - 7	90387-08041	16 - 15	90501-052G5	15 - 12	93106-30001	27 - 5	93450-19052	3 - 4
90151-04003	19 - 2	90201-10032	31 - 16	90387-085E1	2 - 5	90501-06022	14 - 16	93106-30045	27 - 6		37 - 5
90151-06045	11 - 22	90201-105P3	12 - 4	90387-086N4	16 - 19	90501-147A5	11 - 20	93109-11073	4 - 4	93507-16020	2 - 21
90151-06051	26 - 2	90201-12028	21 - 10	90387-124F4	15 - 3	90501-16016	11 - 5	93109-21001	19 - 28	93507-32009	11 - 21
90154-05022	35 - 9	90201-12038	33 - 5	90387-14016	19 - 29	90501-237L0	12 - 11	93109-25001	19 - 22	93603-14240	2 - 22
90157-06008	9 - 14	90201-12575	15 - 4	90387-152F2	2 - 17	90501-256L2	2 - 14	93109-28043	19 - 7	93604-08071	1 - 4
90159-06010	12 - 12	90201-125L6	12 - 21	90387-16025	19 - 23	90506-16007	31 - 5	93210-11073	31 - 3	93604-10011	4 - 11
90159-06021	18 - 18	90201-14020	19 - 32	90387-18004	19 - 8	90507-14064	14 - 8	93210-15639	1 - 23	93604-29184	2 - 23
90170-20255	12 - 18	90201-150U6	2 - 16	90387-18007	9 - 12	90507-20052	8 - 3	93210-17570	11 - 23	93612-16254	9 - 11
90170-24003	21 - 6	90201-16018	19 - 19	90387-18012	19 - 9	90508-155B8	1 - 31	93210-19123	10 - 19	9383E-13216	13 - 28
90176-08005	1 - 5	90201-162H4	11 - 10	90387-2113G	13 - 8	90508-28015	31 - 13	93210-21001	35 - 8	9383E-14215	13 - 28
90179-06028	19 - 15	90201-167P7	11 - 6	90387-227H7	29 - 18	90508-28018	31 - 14	93210-22298	13 - 27	94108-21012	25 - 7
90179-08019	27 - 24	90201-20020	27 - 27	90387-2515B	13 - 26	90508-291A8	15 - 5	93210-74316	1 - 19	94108-21025	25 - 7
90179-08674	16 - 28	90201-20276	11 - 15	90401-10172	30 - 3	90508-30743	11 - 9	93211-02703	1 - 20	94108-2112Y	25 - 7
90179-10658	16 - 24	90201-20685	11 - 2		32 - 13	91312-04006	2 - 9	93300-60801	2 - 10	94111-19011	27 - 10
	16 - 31	90201-21014	19 - 25	90430-05242	12 - 28	91312-04008	1 - 37		2 - 11	94111-19015	27 - 10
	16 - 34	90201-24016	21 - 7	90430-06014	4 - 12	91312-06012	9 - 22	93300-60839	16 - 18	94111-1913A	27 - 10
90179-10M35	1 - 18	90201-253K0	13 - 4		10 - 21	91312-06025	6 - 10	93306-00105	4 - 6	94209-21229	25 - 8
90179-12004	33 - 4		13 - 19	90430-10005	30 - 2	91312-06050	9 - 3	93306-00426	13 - 12	94211-19273	27 - 11
90179-16011	25 - 14	90201-286K9	21 - 4		32 - 14	91312-06060	9 - 4	93306-00442	13 - 11	94211-19274	27 - 11
90179-20255	13 - 30	90202-05193	23 - 22	90430-12227	9 - 19	91312-06070	9 - 5	93306-07202	27 - 4	94227-21101	25 - 8
90179-28013	21 - 3	90209-06096	6 - 23	90445-08376	9 - 9	91402-20012	31 - 4	93306-20540	13 - 2	94309-21161	25 - 9
90183-06023	6 - 26	90209-16011	19 - 24	90445-09003	23 - 3	91402-25015	31 - 12	93306-20574	13 - 24	94311-19155	27 - 12
90185-08008	27 - 17	90209-21332	13 - 10	90445-09005	23 - 5	91A20-05065	5 - 3	93306-27212	27 - 3	94321-19157	27 - 12
90185-08009	16 - 21		13 - 17	90445-09777	1 - 47	92012-06010	8 - 17	93306-37808	3 - 13	94330-21084	25 - 9
90185-10012	20 - 24	90209-24327	3 - 12	90445-111J0	23 - 20	92502-06030	10 - 3		3 - 16	94416-21034	25 - 5
90185-14010	19 - 33		37 - 9	90450-25001	5 - 12		10 - 7	93306-90409	25 - 2	94421-19005	27 - 8
90185-16002	19 - 18	90209-26348	13 - 22	90450-28001	5 - 11	92902-03100	6 - 5	93306-90501	14 - 6	94682-28001	27 - 29
90185-20002	27 - 26	90215-20231	12 - 17	90450-51001	6 - 12	92902-05600	1 - 41	93306-90506	14 - 2	94702-00326	1 - 2
90201-03313	6 - 21	90215-21256	13 - 29	90450-70003	6 - 13	92902-06100	24 - 5	93310-218A6	3 - 5	94709-00326	1 - 2
90201-05021	1 - 25	90240-08120	31 - 6	90462-08040	9 - 20	92902-06600	10 - 4		37 - 11	95022-06010	10 - 20
	2 - 4	90240-10004	31 - 11	90462-08041	9 - 21		10 - 8	93310-230T7	12 - 15	95022-06020	15 - 7

NUMERICAL INDEX

PART NO.	REF. NO.	PART NO.	REF. NO.	PART NO.	REF. NO.	PART NO.	REF. NO.	PART NO.	REF. NO.
95022-06025	4 - 13								
	8 - 11								
	10 - 16								
95022-06030	8 - 24								
	10 - 12								
95022-06050	10 - 13								
95022-06065	4 - 14								
	10 - 17								
95022-08040	16 - 16								
95602-10200	20 - 21								
95602-12200	21 - 11								
95612-10660	1 - 14								
	1 - 16								
95701-06500	30 - 14								
97002-05020	1 - 40								
97002-06012	24 - 4								
97004-05012	16 - 6								
97022-06016	11 - 13								
97702-60016	17 - 14								
98502-03008	6 - 4								
	23 - 19								
98502-04012	7 - 25								
98502-04014	7 - 18								
98502-05010	32 - 16								
98502-05012	1 - 24								
98580-04006	7 - 29								
98680-04510	29 - 12								
98680-04516	29 - 13								
98702-06025	23 - 14								
98706-04012	30 - 8								
98902-05012	1 - 27								
	2 - 2								
98902-05016	1 - 46								
98902-06025	23 - 11								
99001-06600	4 - 8								
99009-16400	11 - 7								
99009-20400	11 - 16								
99009-45500	27 - 7								
99530-08016	10 - 11								
99590-14016	1 - 17								
9Y582-28113	27 - 28								