

YAMAHA

PARTS CATALOGUE

YZ250'85 (56A)

1586A-300E1

A2

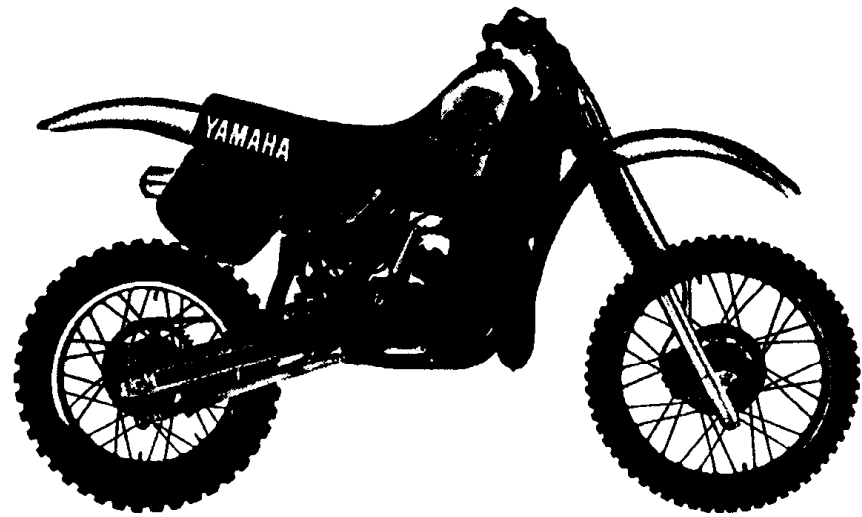

A3

FOREWORD

This Parts Catalogue is related to the parts in use for the Yamaha YZ250 '85 (56A).
When you are ordering replacement parts for the YZ250 '85 (56A), refer to this Parts Catalogue and quote both part numbers and part names correctly.

1. Modifications or additions which have been made after issue of the Parts Catalogue will be announced in the Yamaha Parts News.
It is advisable that according to the Yamaha Parts News you make necessary corrections to the Parts Catalogue on hand to keep it up-to-date.

2. Abbreviations

The following abbreviations are used in this Parts Catalogue.

- U.R. Use size (thickness) and/or number as required.
- U.N. Use as many as you need.
- A.P. Alternate Parts
- L.M. Local Made
- F# Frame No. (Applicable machine No.)

3. The parts marked with (+) in the parts number column of this Catalogue are not supplied with by Yamaha, those have to be found locally.
4. Parts, which are to be supplied in the form of assemblies, are listed with an indentation of one letter's space, and a dot (.) is put against the name of each part.

EXAMPLE
 CARBURETOR ASS'Y
 . JET, pilot
 . NOZZLE, main

5. Indication of No. of constituent parts for assembly

The numeral appearing to the right of each constituent part under the description indicates the quantity of such parts for each individual assembly unit.

EXAMPLE

Part No.	Description	Q'ty	Remarks
2F5-83310-60	FRONT FLASHER LIGHT ASS'Y	2	
115-83311-60	. BULB (6V-18W)	1	
1M1-83309-60	. REFLECTOR	1	

6. Initial Serial No. and Color Code

(A) Frame Serial No.	56A-000101 and following
(B) Engine Serial No.	56A-000101 and following

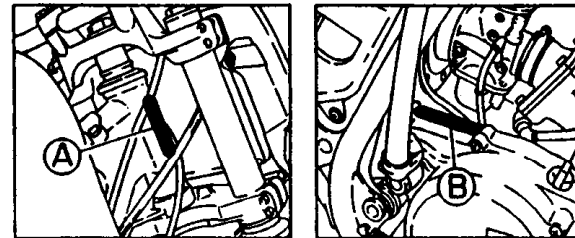

Color Code	Color Name	Abbreviate
36	Clean White	W

7. Applicable colors of graphics are represented in the "Remarks" column by the letter(s) appropriately picked out of the full word(s) showing such colors.

EXAMPLE

Part No.	Description	Q'ty	Remarks
2N4-24110-00-X5	FUEL TANK COMP.	1	MAXIM RED
3J1-24240-10	. GRAPHIC, fuel tank set	1	for MXR

CONTENTS

ENGINE

Cylinder	B2 ~ B3
Governor	B4
Crankshaft · Piston	B5
Water Pump	B6
Radiator · Hose	B7 ~ B8
Intake	B9 ~ B10
Carburetor	B11 ~ B12
Exhaust	B13
Crankcase	B14
Crankcase Cover 1	B15
Starter	C2
Clutch	C3
Transmission	C4 ~ C5
Shift Cam · Fork	C6
Shift Shaft	C7

CHASSIS

Frame	C8
Fender	C9
Side Cover	C10
Rear Arm	C11 ~ C12
Rear Suspension	C13 ~ C14
Steering	C15
Front Fork	D2 ~ D4
Fuel Tank	D5
Seat	D6
Front Wheel	D7
Front Brake Caliper	D8
Rear Wheel	D9 ~ D10

Steering Handle · Cable	D11
Front Master Cylinder	D12
Stand · Footrest	D13
Generator	D14
Handle Switch · Lever	D15
Electrical 1	E2

ALTERNATE PARTS

Alternate (Chassis)	E3
---------------------------	----

REPAIR KIT

Repair Kit	E4
------------------	----

INDEX

Numerical Index	M1 ~ M3
-----------------------	---------

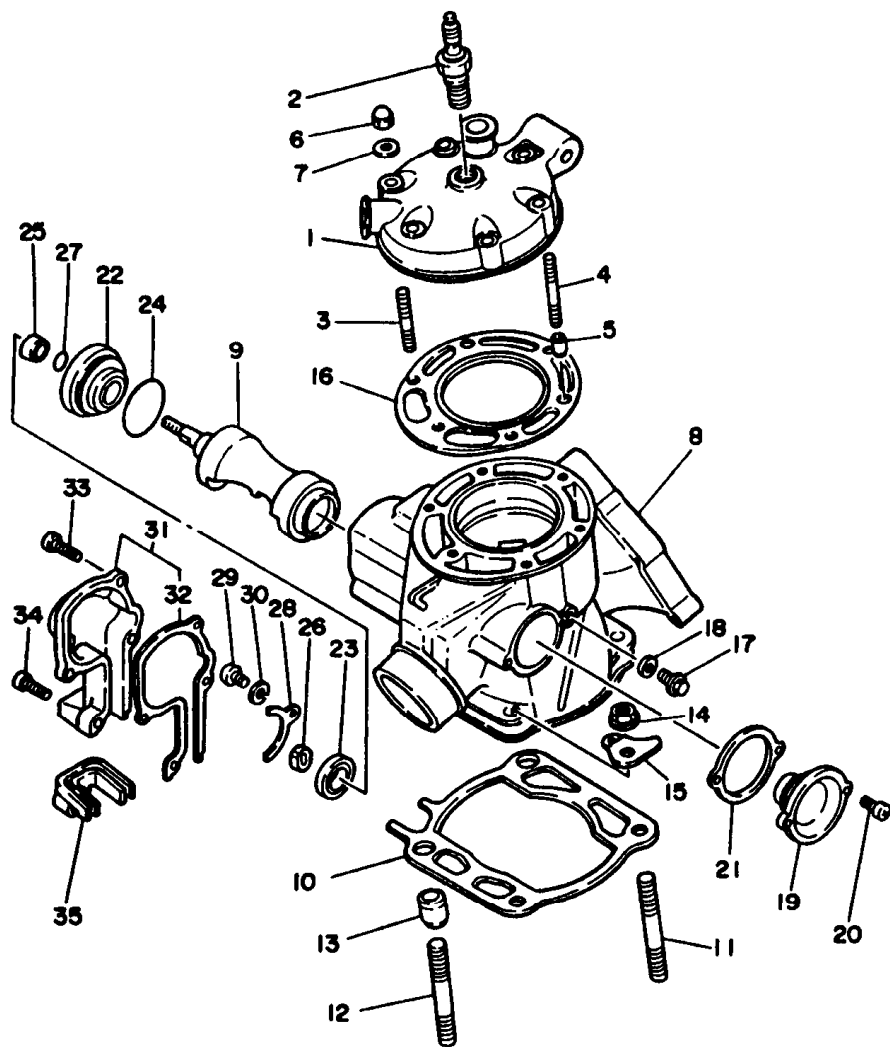

56A110-5010

FIG. 1 CYLINDER

REF. NO.	PART NO.	DESCRIPTION	Q'TY	REMARKS
1	56A-11111-00	HEAD, cylinder 1	1	
2	*	PLUG, spark (CHAMPION N-86)	1	LM
3	90116-08394	BOLT, stud	4	
4	90116-08392	BOLT, stud	2	
5	91810-03014	PIN, dowel	2	
6	90176-08026	NUT, crown	6	
7	90201-08087	WASHER, plate	6	
8	56A-11311-00	CYLINDER 1	1	
9	56A-1131A-00	VALVE 1	1	
10	39X-11351-00	GASKET, cylinder	1	
11	90116-10313	BOLT, stud	2	
12	90116-10314	BOLT, stud	2	
13	91830-24016	PIN, dowel	2	
14	95701-10500	NUT, flange	4	
15	39X-14619-00	HOOK, spring	1	
16	56A-11181-00	GASKET, cylinder head 1	1	
17	95806-06012	BOLT, flange	1	
18	90430-06192	GASKET	1	
19	39X-W1132-00	HOLDER 1	1	
20	98506-05012	SCREW, pan head	2	
21	5X5-1131N-00	GASKET, holder	1	
22	5X5-W1133-00	HOLDER 2	1	
23	93104-16074	OIL SEAL	1	
24	93210-35512	O-RING	1	
25	90387-102F3	COLLAR	1	
26	5X5-11937-00	BOSS, lever	1	
27	93210-09192	O-RING	1	
28	56A-11915-00	PLATE, thrust 1	1	

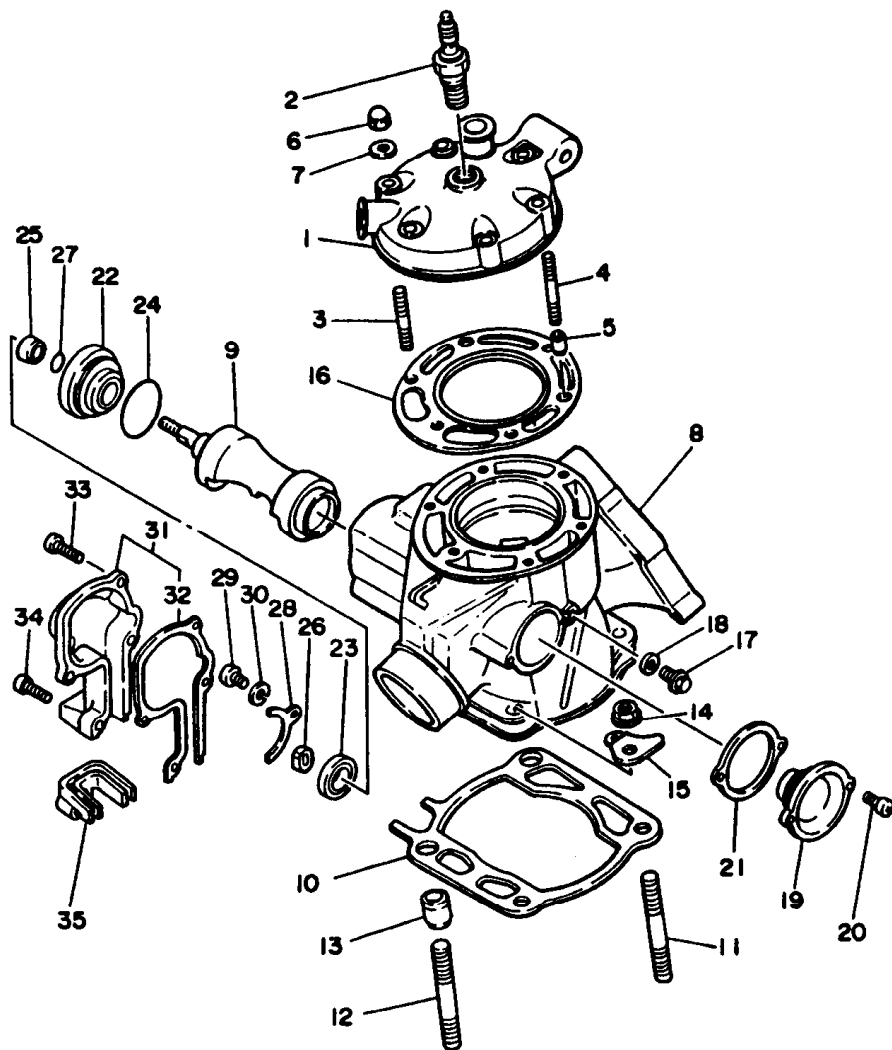

FIG. 1 CYLINDER

REF. NO.	PART NO.	DESCRIPTION	Q'TY	REMARKS
29	98501-05012	SCREW, pan head	1	
30	92901-05100	WASHER, spring	1	
31	39X-11992-00	HOUSING 2	1	
32	39X-11993-00	.GASKET	1	
33	98506-05018	SCREW, pan head	3	
34	98506-05014	SCREW, pan head	1	
35	39X-11995-00	SEAL, housing	1	



56A110-5010

B3

FIG. 2 GOVERNOR

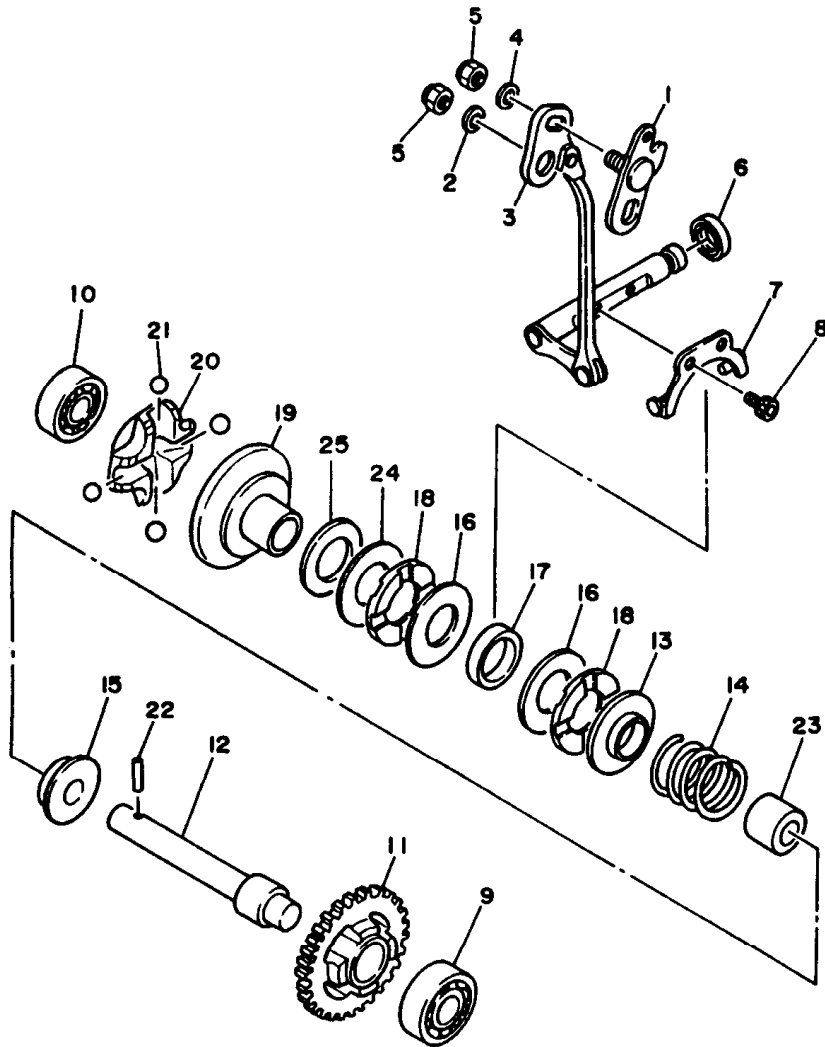

REF. NO.	PART NO.	DESCRIPTION	Q'TY	REMARKS
1	5X5-11931-00	LEVER	1	
2	90201-057H5	WASHER, plate	1	
3	24Y-11990-00	PUSH ROD ASSY	1	
4	92901-05600	WASHER, plate	1	
5	95601-05100	NUT, u	2	
6	93104-08040	OIL SEAL	1	
7	5X5-11922-00	FORK, governor	1	
8	91316-04006	BOLT	2	
9	93306-00006	BEARING (B6000)	1	
10	93300-60801	BEARING (B0060)	1	
11	5X5-11953-00	GEAR, governor (29T)	1	
12	5X5-11921-00	SHAFT, governor	1	
13	5X5-11951-00	PLATE	1	
14	90501-24745	SPRING, compression	1	
15	5X5-11952-00	PLATE	1	
16	90201-151A7	WASHER, plate (T=1.0)	2	
17	90387-152F2	COLLAR	1	
18	90380-15104	BUSH, solid	2	
19	5X5-11912-01	RETAINER, weight	1	
20	5X5-11911-01	RETAINER	1	
21	93521-64032	BALL	4	
22	93603-14179	PIN, dowel	1	
23	90387-083F4	COLLAR	1	
24	90201-151A7	WASHER, plate (T=1.0)	1	UR
	90201-154F5	WASHER, plate (T=0.8)	1	UR
25	90201-154F6	WASHER, plate	1	UN



24Y100-3021

B4

FIG. 3 CRANKSHAFT. PISTON

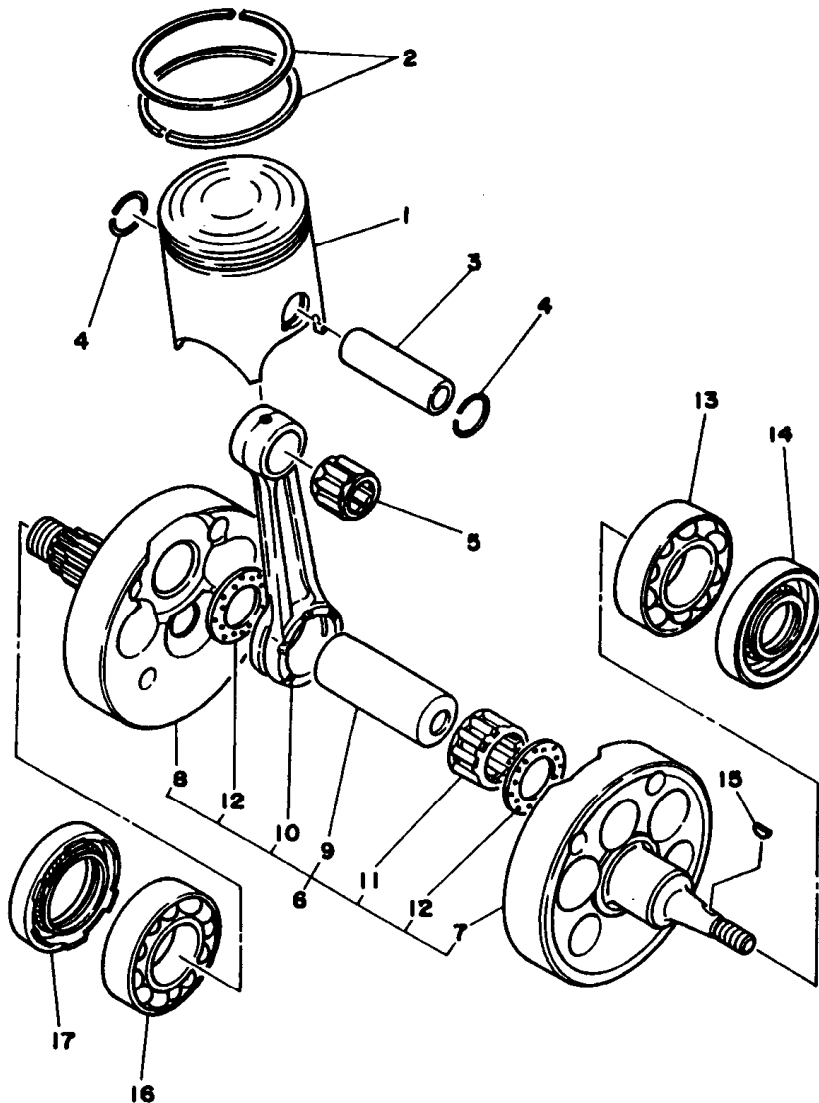

REF. NO.	PART NO.	DESCRIPTION	Q'TY	REMARKS
1	56A-11631-00-93	PISTON (STD)	1	
	56A-11631-00-94	PISTON (STD)	1	
	56A-11635-00	PISTON (0.25MM O/S)	1	AP
	56A-11636-00	PISTON (0.50MM O/S)	1	AP
	56A-11637-00	PISTON (0.75MM O/S)	1	AP
2	56A-11601-00	PISTON RING SET (STD)	1	
	56A-11601-10	PISTON RING SET (1ST O/S)	1	AP
	56A-11601-20	PISTON RING SET (2ND O/S)	1	AP
	56A-11601-30	PISTON RING SET (3RD O/S)	1	AP
3	214-11633-00	PIN, piston	1	
4	93450-19052	CIRCLIP	2	
5	93310-418E9	BEARING, cylindrical	1	
6	56A-11400-00	CRANKSHAFT ASSY	1	
7	24Y-11412-01	.CRANK 1	1	
8	24Y-11422-01	.CRANK 2	1	
9	2X4-11681-00	.PIN, crank 1	1	
10	24Y-11651-00	.ROD, connecting	1	
11	93310-425N4	.BEARING, cylindrical	1	
12	90209-25085	.WASHER	2	
13	93306-20627	BEARING	1	
14	93103-30092	OIL SEAL	1	
15	90280-03017	KEY, woodruff	1	
16	93306-20627	BEARING	1	
17	93103-40091	OIL SEAL	1	

56A110-5030

B5

FIG. 4 WATER PUMP

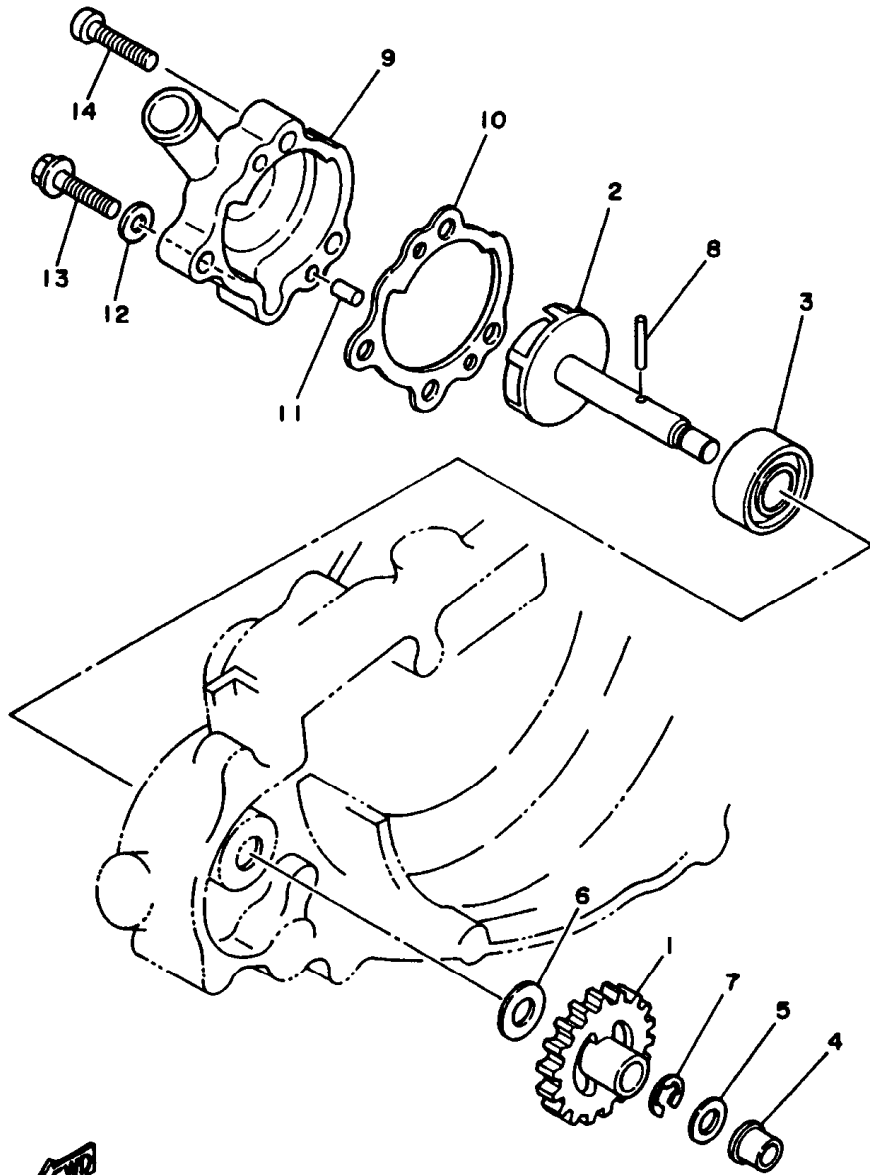

REF. NO.	PART NO.	DESCRIPTION	Q'TY	REMARKS
1	39X-12459-00	GEAR, impeller shaft	1	
2	39X-12450-00	IMPELLER SHAFT ASSY	1	
3	93103-10113	OIL SEAL	1	
4	90381-08002	BUSH, solid	1	
5	90201-08512	WASHER, plate	1	
6	90201-10138	WASHER, plate	1	
7	93430-07012	CIRCLIP	1	
8	93603-22028	PIN, dowel	1	
9	39X-12422-00	COVER, housing	1	
10	5X5-12428-00	GASKET, housing cover 2	1	
11	93604-10011	PIN, dowel	2	
12	90430-06166	GASKET	1	
13	95826-06025	BOLT, flange	1	
14	92506-06025	SCREW, pan head	3	

39X100-4040

B6

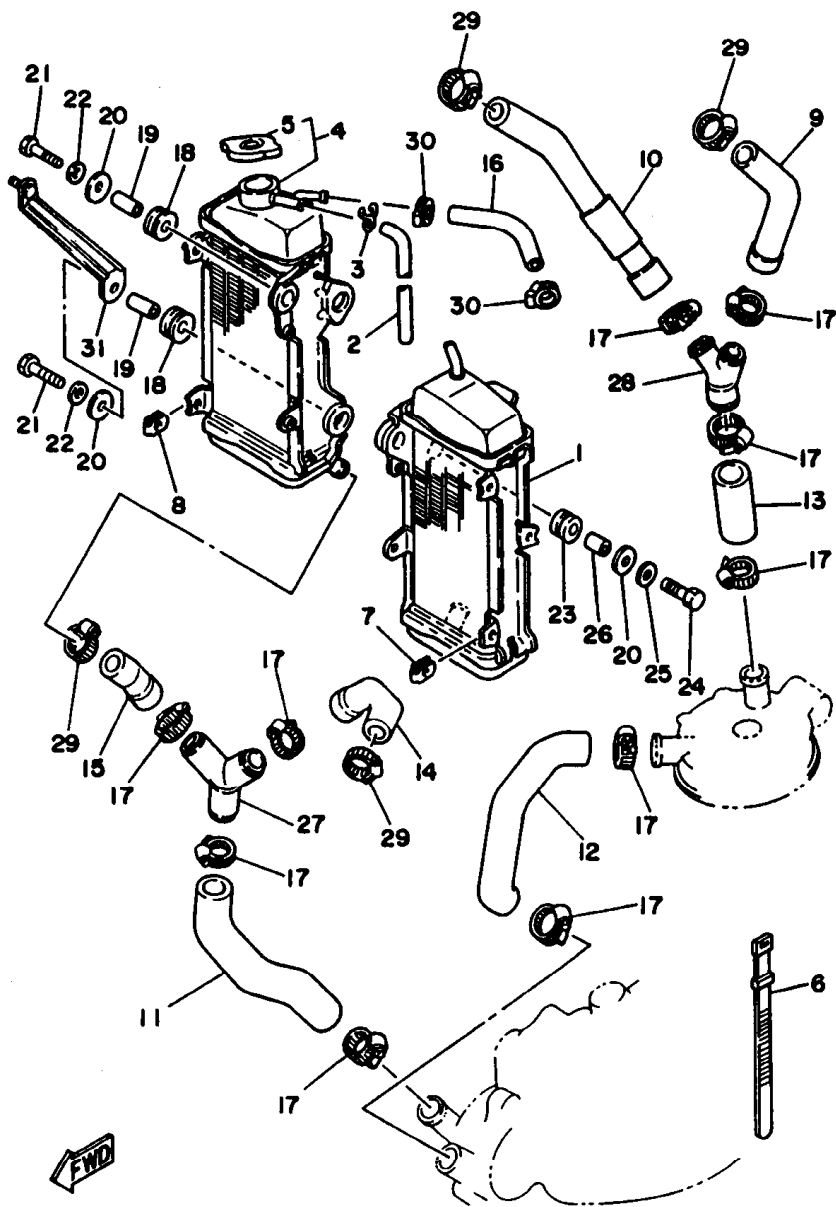

56A110-5050

FIG. 5 RADIATOR. HOSE

REF. NO.	PART NO.	DESCRIPTION	Q'TY	REMARKS
1	39X-12460-01	RADIATOR ASSY	1	
2	90446-09079	HOSE	1	
3	90467-09006	CLIP	1	
4	39X-1240A-01	RADIATOR ASSY 2	1	
5	22W-12462-00	.CAP, radiator	1	
6	437-83936-10	BAND, switch cord	1	
7	22W-21791-00	NUT	2	
8	22W-21791-00	NUT	2	
9	39X-12481-00	PIPE 1	1	
10	39X-12482-00	PIPE 2	1	
11	39X-12483-00	PIPE 3	1	
12	39X-12484-00	PIPE 4	1	
13	39X-12485-00	PIPE 5	1	
14	39X-12476-00	PIPE 6	1	
15	39X-12477-00	PIPE 7	1	
16	39X-1248A-00	PIPE 8	1	
17	90460-31253	CLAMP, hose	10	
18	90480-15064	GROMMET	4	
19	90387-07392	COLLAR	4	
20	90201-06570	WASHER, plate	6	
21	97301-06030	BOLT	4	
22	90201-061A5	WASHER, plate	4	
23	90480-18276	GROMMET	2	
24	97301-06020	BOLT	2	
25	90201-061A5	WASHER, plate	2	
26	90387-060A7	COLLAR	2	
27	24X-12469-00	JOINT 1	1	
28	24Y-12469-00	JOINT 1	1	

B7

FIG. 5 RADIATOR. HOSE

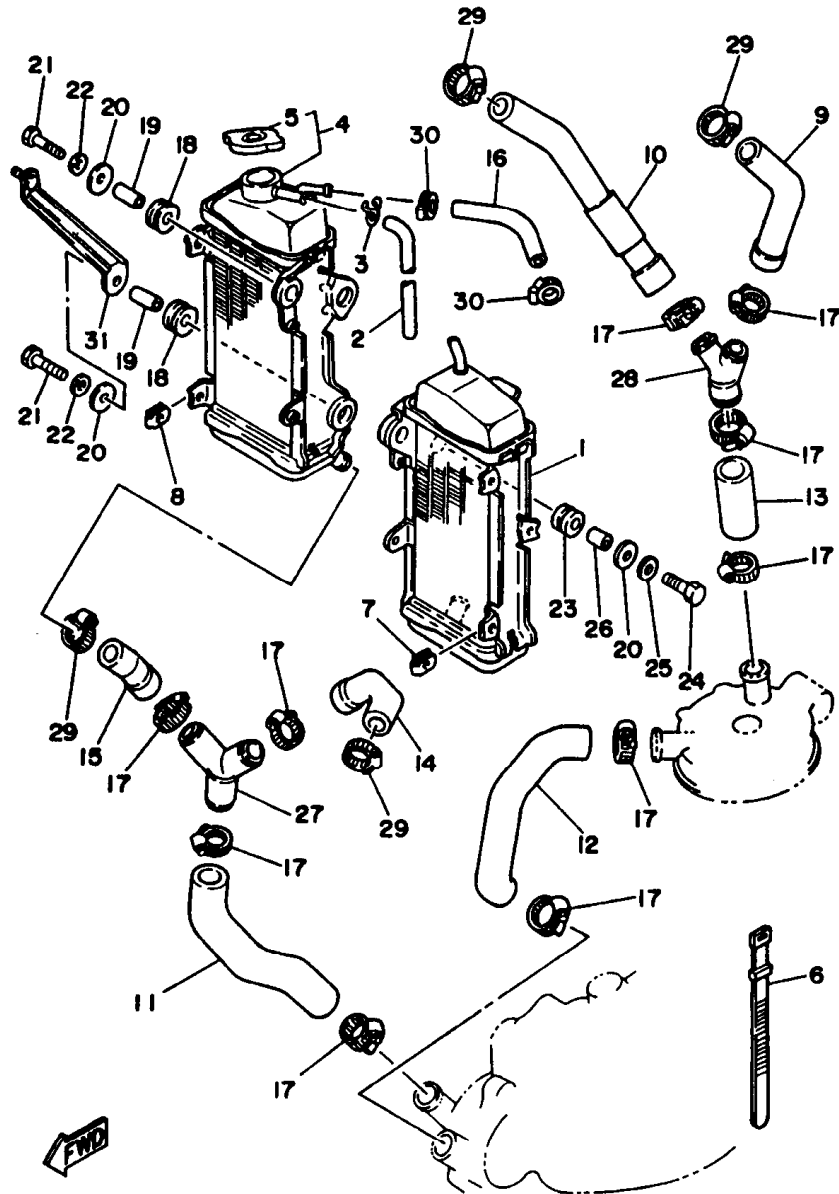

56A110-5050

REF. NO.	PART NO.	DESCRIPTION	Q'TY	REMARKS
29	90460-22252	CLAMP, hose	4	
30	90460-15227	CLAMP, hose	2	
31	56A-12498-00	PROTECTOR	1	

B8

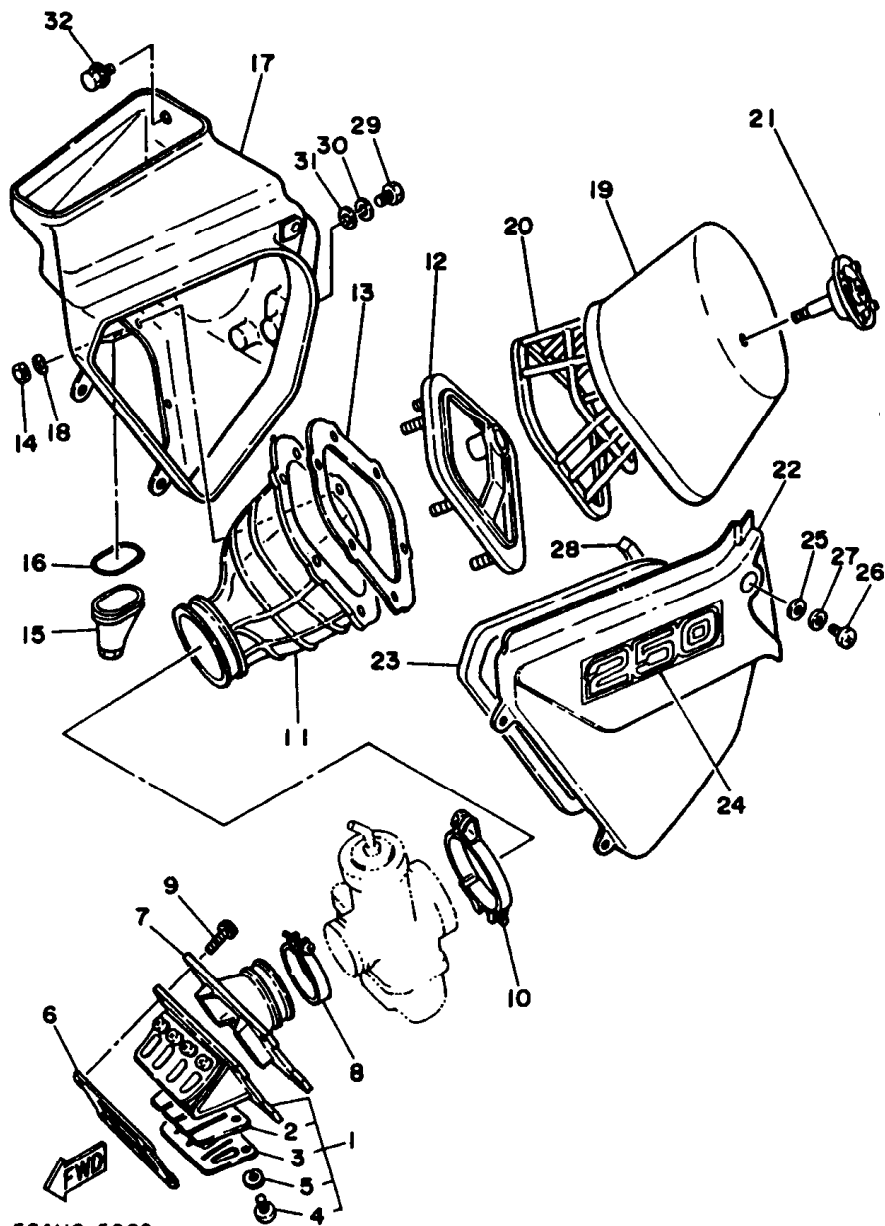

56A110-5060

FIG. 6 INTAKE

REF. NO.	PART NO.	DESCRIPTION	Q'TY	REMARKS
1	56A-13610-00	REED VALVE ASSY	1	
2	56A-13613-00	.REED, valve	2	
3	56A-13616-00	.STOPPER, reed valve	2	
4	98503-03006	.SCREW, pan head	8	
5	92903-03100	.WASHER, spring	8	
6	39X-13621-00	GASKET, valve seat	1	
7	39X-13565-00	JOINT, carburetor	1	
8	90460-51109	CLAMP, hose	1	
9	91316-06020	BOLT	6	
10	90460-68199	CLAMP, hose	1	
11	39X-14453-00	JOINT, air cleaner 1	1	
12	56A-14459-00	HOLDER, guide	1	
13	39X-14462-00	SEAL	1	
14	95601-05100	NUT, u	6	
15	39K-14457-00	SEAL	1	
16	90504-03033	SPRING, compression	1	
17	39X-W1441-00	AIR CLEANER CASE COMP.	1	
18	92901-05200	WASHER, plain	6	
19	39X-14451-00	ELEMENT, air cleaner	1	
20	39X-14458-00	GUIDE	1	
21	56A-14468-00	PLATE, element fitting	1	
22	43N-14412-00	CAP, cleaner case 1	1	white
23	39X-14457-00	SEAL	1	
24	39X-21737-10	EMBLEM	1	for w
25	92901-06200	WASHER, plain	3	
26	92501-06012	SCREW, pan head	3	
27	92901-06100	WASHER, spring	3	
28	39X-14452-00	SEAL	1	

B9

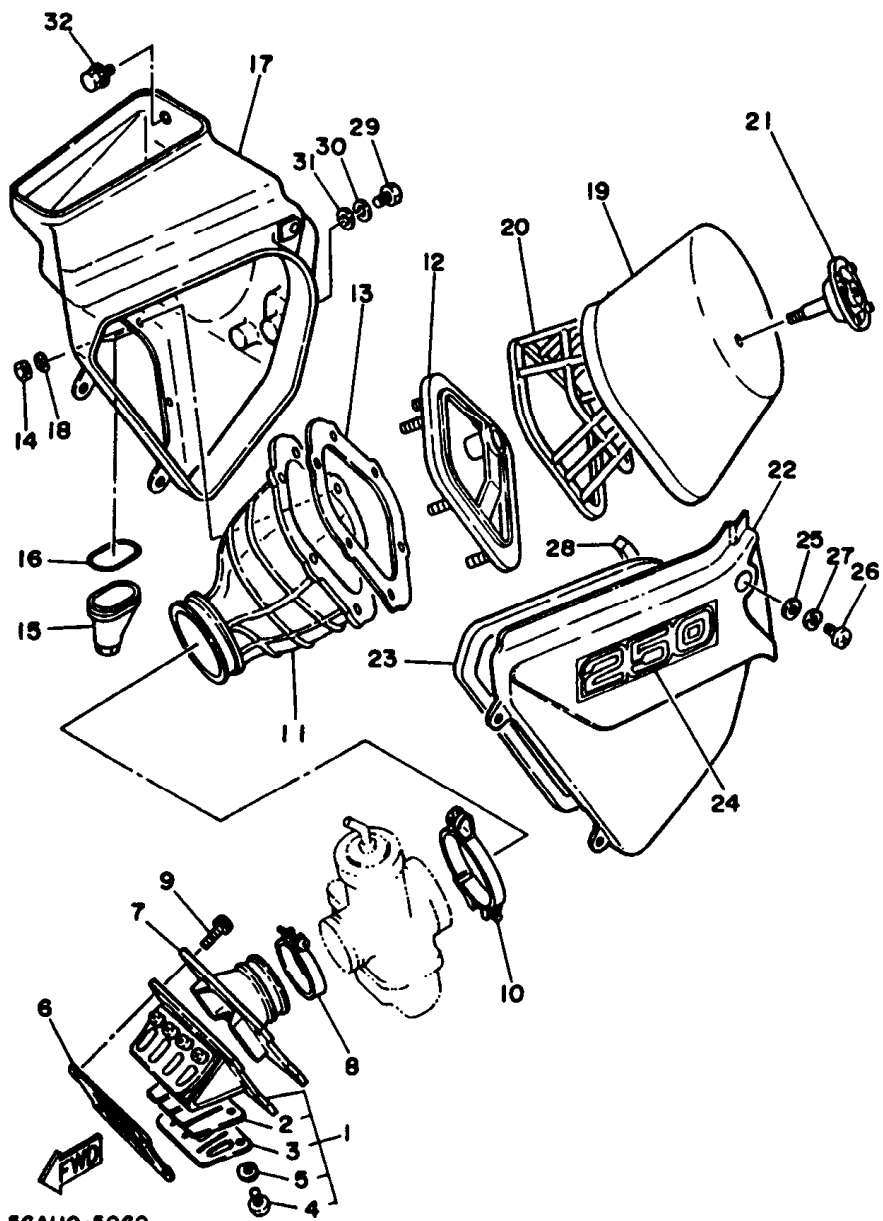
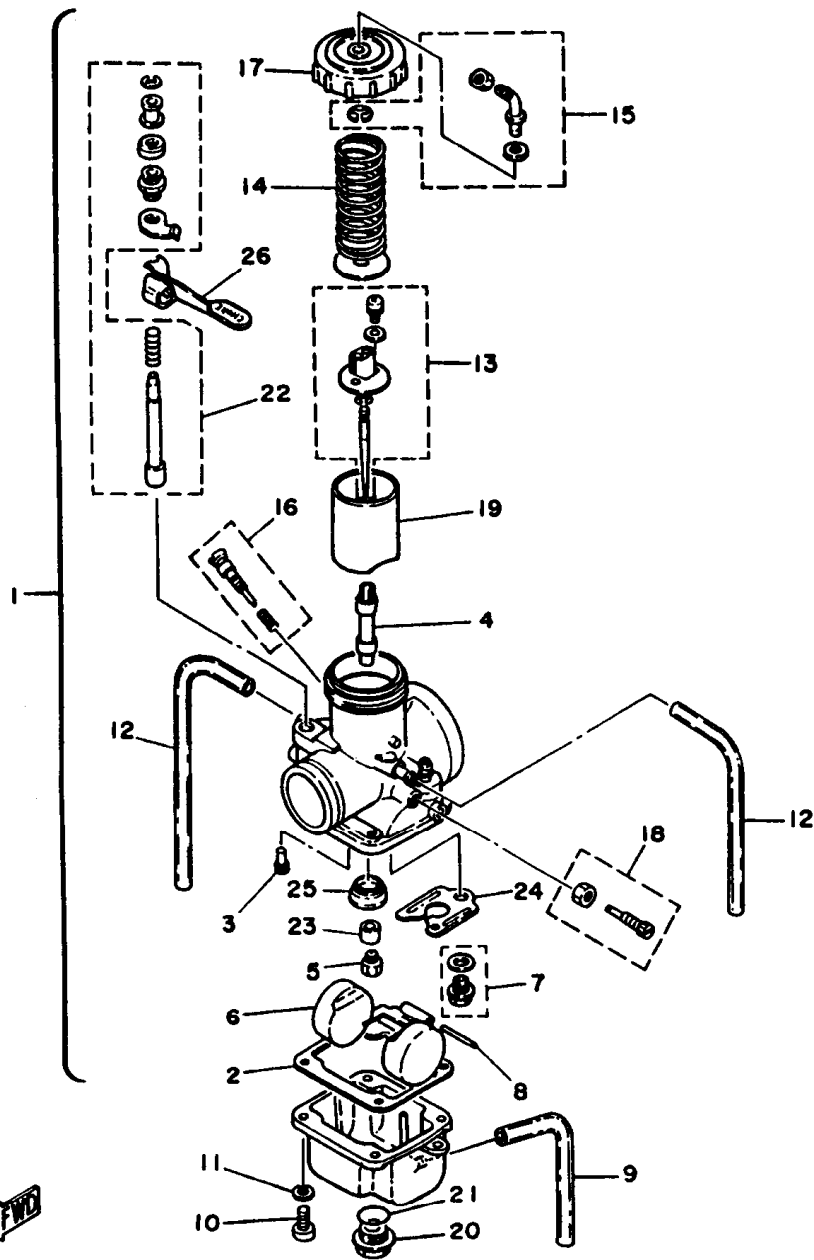

FIG. 6 INTAKE

REF. NO.	PART NO.	DESCRIPTION	Q'TY	REMARKS
29	97301-06012	BOLT	2	
30	92901-06100	WASHER, spring	2	
31	90201-061A5	WASHER, plate	2	
32	90119-06056	BOLT, with washer	1	

56A110-5060



56A110-5070

FIG. 7 CARBURETOR

REF. NO.	PART NO.	DESCRIPTION	Q'TY	REMARKS
1	56A-14101-10	CARBURETOR ASSY 1	1	
2	363-14184-00	.GASKET, float chamber	1	
3	193-14142-60	.JET, pilot (# 60)	1	STD
	193-14142-55	.JET, pilot (# 55)	1	UR AP
	193-14142-65	.JET, pilot (# 65)	1	UR AP
4	510-14141-50	.NOZZLE, main	1	STD
	510-14141-48	.NOZZLE, main	1	UR AP
	510-14141-52	.NOZZLE, main	1	UR AP
5	137-14143-62	.JET, main (#310)	1	STD
	137-14143-60	.JET, main (#300)	1	UR AP
	137-14143-64	.JET, main (#320)	1	UR AP
6	2N7-14185-00	.FLOAT	1	
7	23X-14107-35	.NEEDLE VALVE SET	1	
8	537-14186-00	.PIN, float	1	
9	2K7-14197-00	.PIPE	1	
10	98501-05016	.SCREW, pan head	4	
11	92990-05100	.WASHER, spring	4	
12	310-14197-00	.PIPE	2	
13	23X-1490J-00	.NEEDLE SET	1	
14	431-14131-00	.SPRING, throttle valve	1	
15	23X-14106-00	.CABLE ADJUST SCREW SET	1	
16	23X-14104-00	.AIR SCREW SET	1	
17	5Y9-14158-00	.TOP, mixing chamber	1	
18	23X-14103-00	.THROTTLE SCREW SET	1	
19	2X8-14112-30	.VALVE, throttle 1	1	STD
	2X8-14112-25	.VALVE, throttle 1	1	UR AP
	2X8-14112-35	.VALVE, throttle 1	1	UR AP
20	510-14115-00	.PLUG, screw	1	

B11

FIG. 7 CARBURETOR

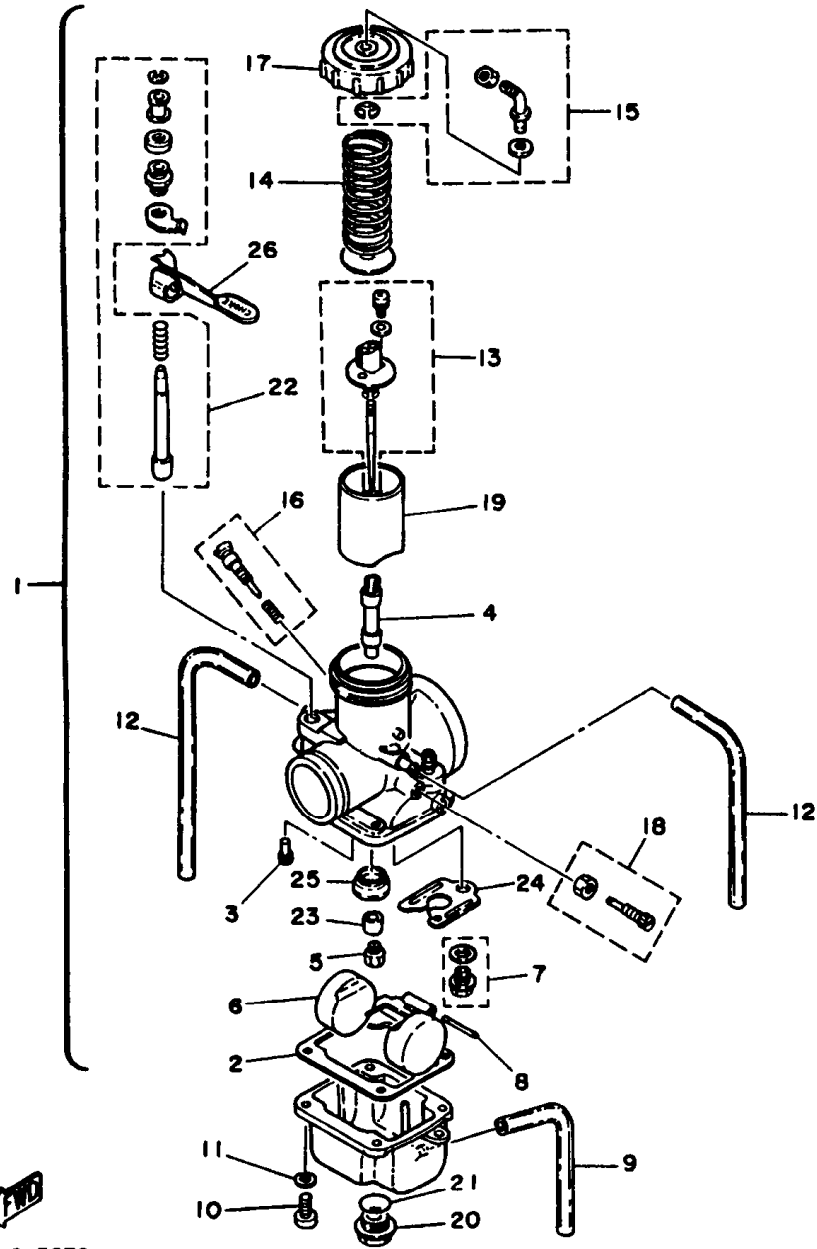

36A110-5070

REF. NO.	PART NO.	DESCRIPTION	Q'TY	REMARKS
21	558-14147-00	.O-RING	1	
22	26A-1410A-00	.STARTER SET	1	
23	5X5-14153-00	.WASHER, main jet	1	
24	3R4-14146-00	.PLATE	1	
25	509-14145-00	.SETTER, needle jet	1	
26	1W3-14173-00	.COVER, plunger cap	1	

B12

FIG. 8 EXHAUST

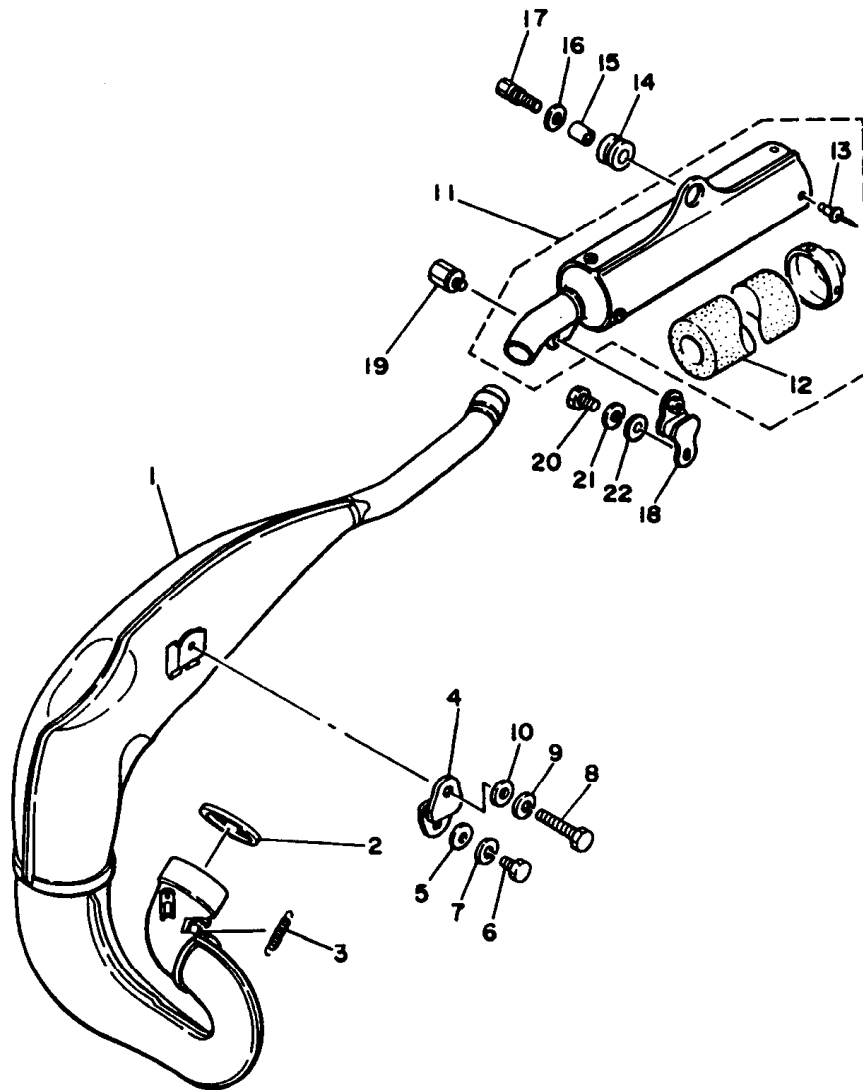

REF. NO.	PART NO.	DESCRIPTION	Q'TY	REMARKS
1	56A-14610-00	EXHAUST PIPE ASSY 1	1	
2	24Y-14613-00	GASKET, exhaust pipe	1	
3	90507-20030	SPRING, tension	3	
4	24Y-14771-00	STAY, muffler 1	1	
5	90201-08730	WASHER, plate	1	
6	97301-08016	BOLT	1	
7	92901-08100	WASHER, spring	1	
8	97301-08060	BOLT	1	
9	92901-08100	WASHER, spring	1	
10	92901-08600	WASHER, plate	1	
11	56A-14753-00	SILENCER, exhaust	1	
12	56A-1469A-00	.FIBER	1	
13	90267-48121	.RIVET, blind	4	
14	39X-14747-00	DAMPER, muffler	1	
15	90387-081A3	COLLAR	1	
16	90201-08612	WASHER, plate	1	
17	90109-08512	BOLT	1	
18	565-14771-00	STAY, muffler 1	1	
19	90109-06551	BOLT	1	
20	97301-06016	BOLT	1	
21	92901-06100	WASHER, spring	1	
22	90201-061A5	WASHER, plate	1	



56A110-5080

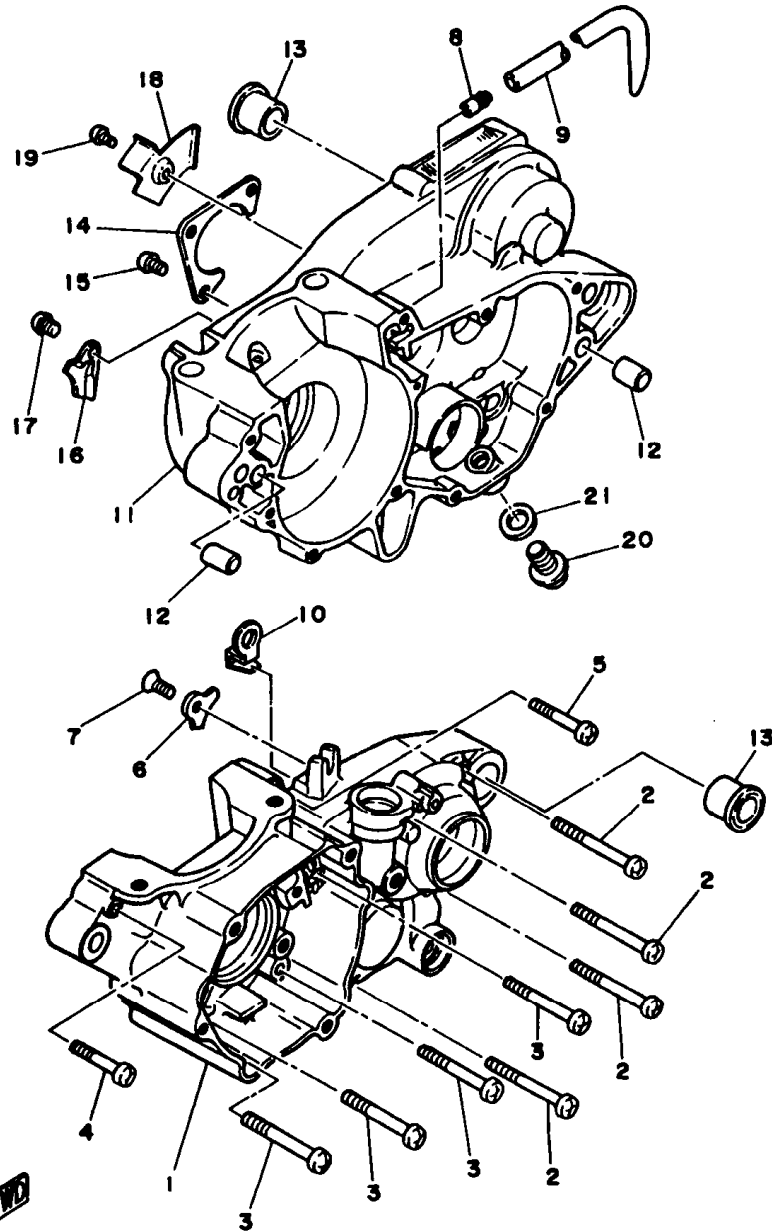

5X5100-2102

FIG. 9 CRANKCASE

REF. NO.	PART NO.	DESCRIPTION	Q'TY	REMARKS
1	5X5-15111-03	CRANKCASE 1	1	
2	91316-06060	BOLT	4	
3	91316-06055	BOLT	4	
4	91316-06045	BOLT	1	
5	91316-06040	BOLT	1	
6	56A-15383-00	PLATE, bearing cover	1	
7	92701-06012	SCREW, flat head	1	
8	137-13115-00	CONNECTOR, suction pipe	1	
9	90445-08605	HOSE	1	
10	23X-26393-00	HOLDER	1	
11	5X5-15121-01	CRANKCASE 2	1	
12	91810-05016	PIN, dowel	4	
13	90387-160H4	COLLAR	2	
14	23X-15381-00	PLATE, bearing cover	1	
15	92501-06012	SCREW, pan head	3	
16	3R4-15118-00	HOLDER	1	
17	92501-08010	SCREW, pan head	1	
18	5X5-15113-00	PLATE	1	
19	92501-06010	SCREW, pan head	1	
20	90340-12095	PLUG, straight screw	1	
21	90430-12038	GASKET	1	

FIG. 10 CRANKCASE COVER 1

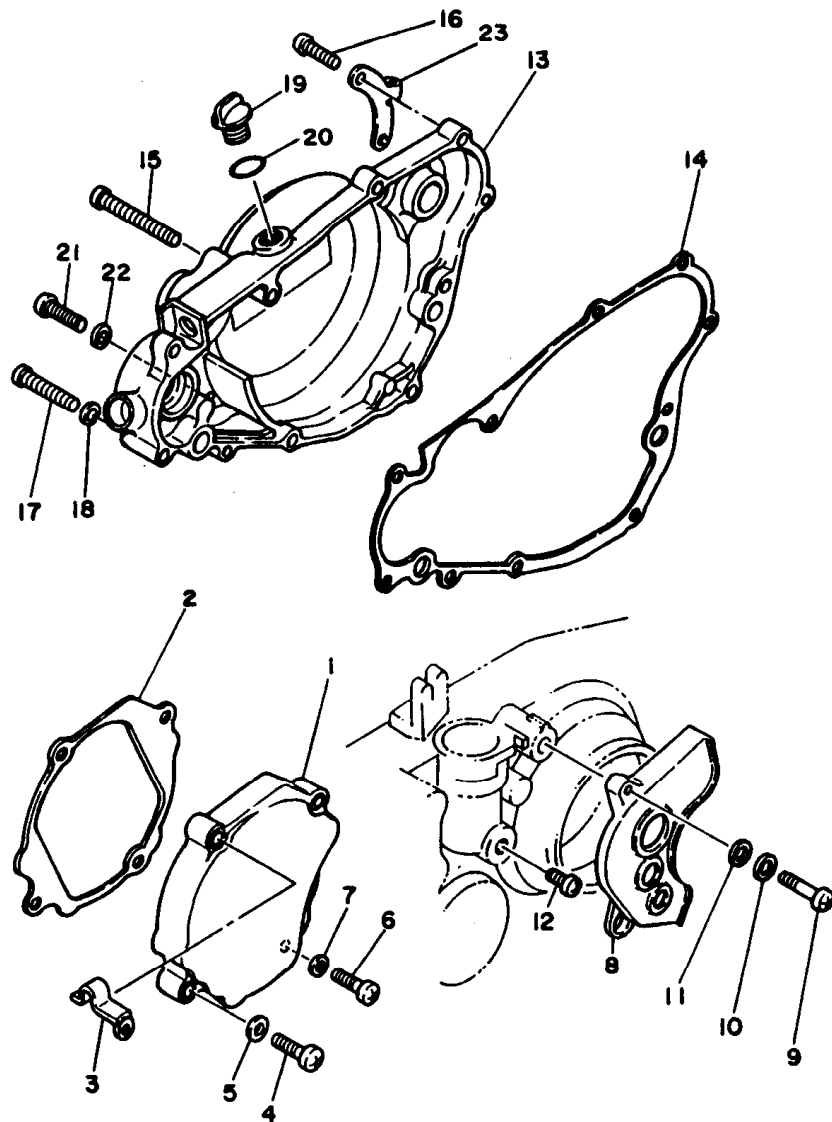

REF. NO.	PART NO.	DESCRIPTION	Q'TY	REMARKS
1	39X-15411-00	COVER, crankcase 1	1	
2	5X5-15451-00	GASKET, crankcase cover 1	1	
3	90465-06247	CLAMP	1	
4	92506-06030	SCREW, pan head	3	
5	92906-06600	WASHER, plate	3	
6	92506-06025	SCREW, pan head	1	
7	92906-06600	WASHER, plate	1	
8	23X-15421-00	COVER, crankcase 2	1	
9	92506-06025	SCREW, pan head	1	
10	92906-06100	WASHER, spring	1	
11	92906-06600	WASHER, plate	1	
12	92506-06012	SCREW, pan head	1	
13	24Y-15431-00	COVER, crankcase 3	1	
14	5X5-15462-00	GASKET, crankcase cover 3	1	
15	92506-06065	SCREW, pan head	1	
16	92506-06025	SCREW, pan head	8	
17	92506-06040	SCREW, pan head	1	
18	92906-06600	WASHER, plate	1	
19	168-15362-00	PLUG, oil level	1	
20	93210-14104	O-RING	1	
21	92506-06008	SCREW, pan head	1	
22	90430-06016	GASKET	1	
23	56A-15378-00	HOLDER	1	

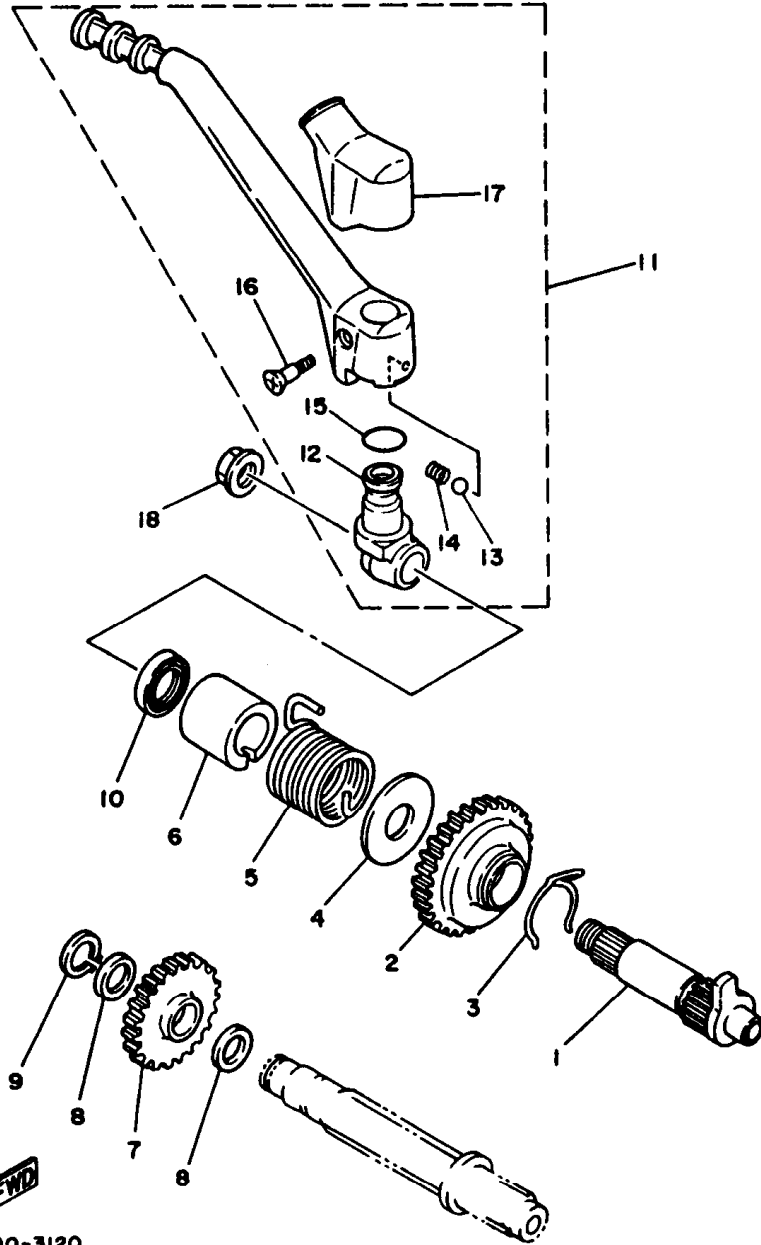

36A110-5100

FIG. 11 STARTER

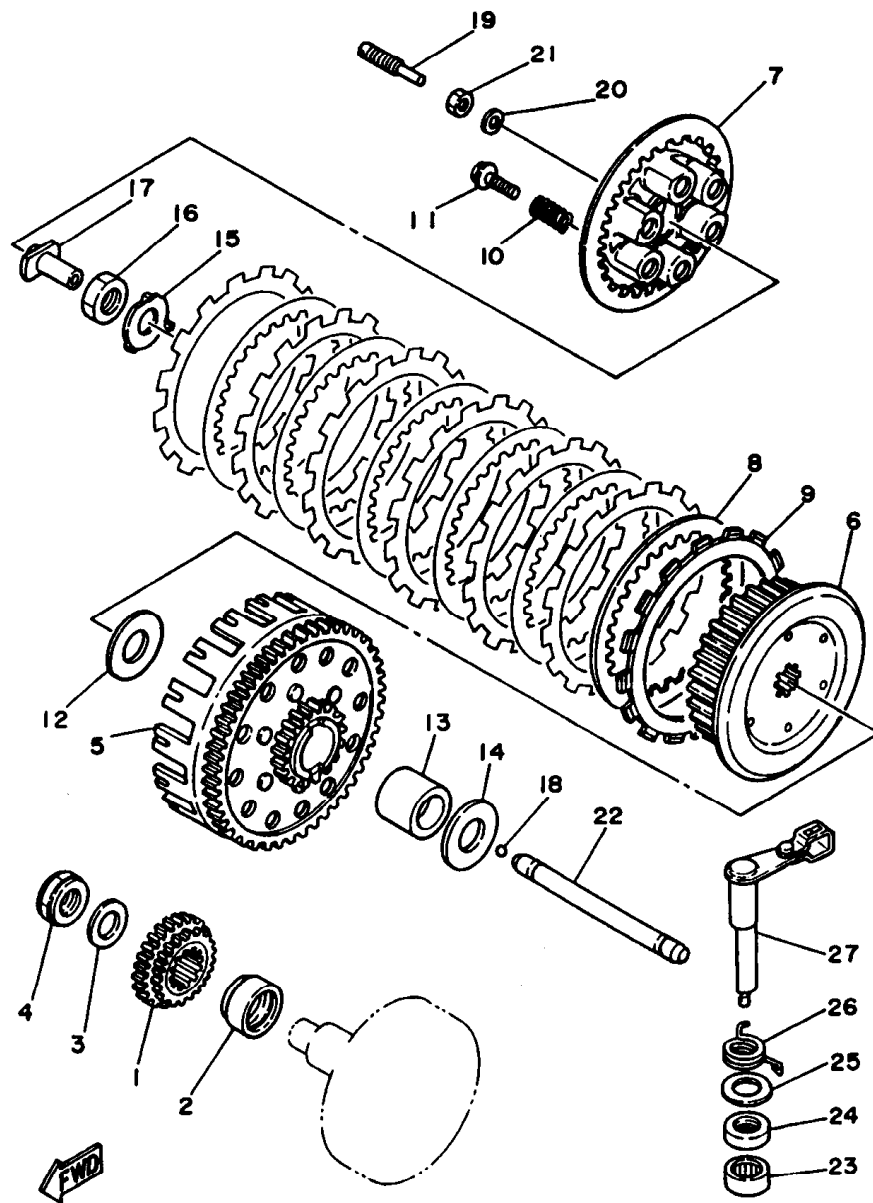

24Y100-3120

REF. NO.	PART NO.	DESCRIPTION	Q'TY	REMARKS
1	56A-15661-00	AXLE, kick	1	
2	3R4-15641-00	GEAR, kick (26T)	1	
3	90468-26048	CLIP	1	
4	90201-20358	WASHER, plate	1	
5	90508-30422	SPRING, torsion	1	
6	3R4-15664-00	GUIDE, spring	1	
7	3R4-15651-00	GEAR, sprocket idle (21T)	1	
8	90201-17545	WASHER, plate	2	
9	93410-17008	CIRCLIP	1	
10	93102-20309	OIL SEAL	1	
11	56A-15620-00	KICK CRANK ASSY	1	
12	24Y-15621-00	.BOSS, kick crank	1	
13	93501-04011	.BALL	1	
14	90501-13720	.SPRING, compression	1	
15	93210-19216	.O-RING	1	
16	90152-06010	.SCREW, countersunk	1	
17	24Y-15618-00	.COVER, kick lever	1	
18	90179-12244	NUT	1	



56A110-5120

FIG. 12 CLUTCH

REF. NO.	PART NO.	DESCRIPTION	Q'TY	REMARKS
1	24Y-16110-00	PRIMARY DRIVE GEAR ASSY	1	
2	90387-252F6	COLLAR	1	
3	90201-186H3	WASHER, plate	1	
4	90185-18126	NUT, self-locking	1	
5	39X-16150-00	PRIMARY DRIVEN GEAR COMP.	1	
6	23X-16371-00	BOSS, clutch	1	
7	23X-16351-00	PLATE, pressure 1	1	
8	4H7-16325-00	PLATE, clutch 2	6	
9	5X5-16321-00	PLATE, friction	7	
10	90501-23346	SPRING, compression	6	
11	90159-06016	SCREW, with washer	6	
12	2K7-16154-00	PLATE, thrust 1	1	
13	2K7-16181-00	SPACER 1	1	
14	2K7-16154-00	PLATE, thrust 1	1	
15	90215-20212	WASHER, lock	1	
16	90170-20255	NUT	1	
17	23X-16356-00	ROD, push 1	1	
18	93515-32029	BALL	1	
19	90149-06178	SCREW	1	
20	92901-06100	WASHER, spring	1	
21	95301-06600	NUT	1	
22	2K7-16357-01	ROD, push 2	1	
23	93315-21721	BEARING, cylindrical	1	
24	93102-17263	OIL SEAL	1	
25	90201-17327	WASHER, plate	1	
26	90508-14423	SPRING, torsion	1	
27	38W-16380-00	PUSH LEVER ASSY	1	

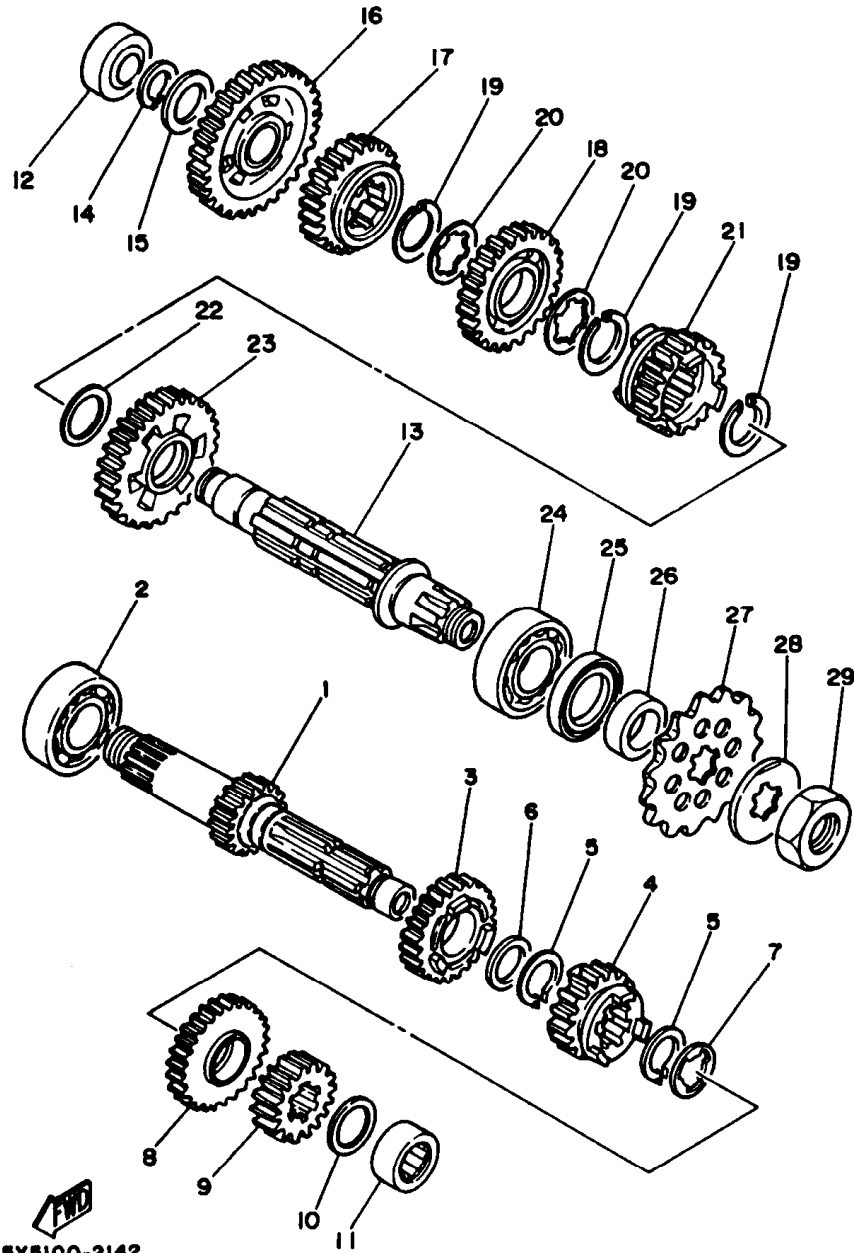

FIG. 13 TRANSMISSION

REF. NO.	PART NO.	DESCRIPTION	Q'TY	REMARKS
1	24Y-17411-00	AXLE, main	1	
2	93300-20501	BEARING	1	
3	39X-17141-00	GEAR, 4th pinion (20T)	1	
4	39X-17131-00	GEAR, 3rd pinion (18T)	1	
5	93410-22039	CIRCLIP	2	
6	90201-22555	WASHER, plate	1	
7	90209-18135	WASHER	1	
8	39X-17151-00	GEAR, 5th pinion (22T)	1	
9	24Y-17121-00	GEAR, 2nd pinion (16T)	1	
10	90209-17235	WASHER	1	
11	93311-41734	BEARING, cylindrical	1	
12	93311-62035	BEARING, cylindrical	1	
13	5X5-17421-00	AXLE, drive	1	
14	93410-20038	CIRCLIP	1	
15	90201-20278	WASHER, plate	1	
16	24Y-17211-00	GEAR, 1st wheel (30T)	1	
17	39X-17241-00	GEAR, 4th wheel (24T)	1	
18	39X-17231-00	GEAR, 3rd wheel (26T)	1	
19	93440-25084	CIRCLIP	3	
20	90209-22082	WASHER	2	
21	39X-17251-00	GEAR, 5th wheel (22T)	1	
22	256-17154-00-10	WASHER, gear hold	1	
23	24Y-17221-00	GEAR, 2nd wheel (28T)	1	
24	93300-20501	BEARING	1	
25	93102-32M07	OIL SEAL	1	
26	90387-25663	COLLAR	1	
27	23X-17461-40	SPROCKET, drive (14T)	1	STD
	23X-17461-30	SPROCKET, drive (13T)	1	AP

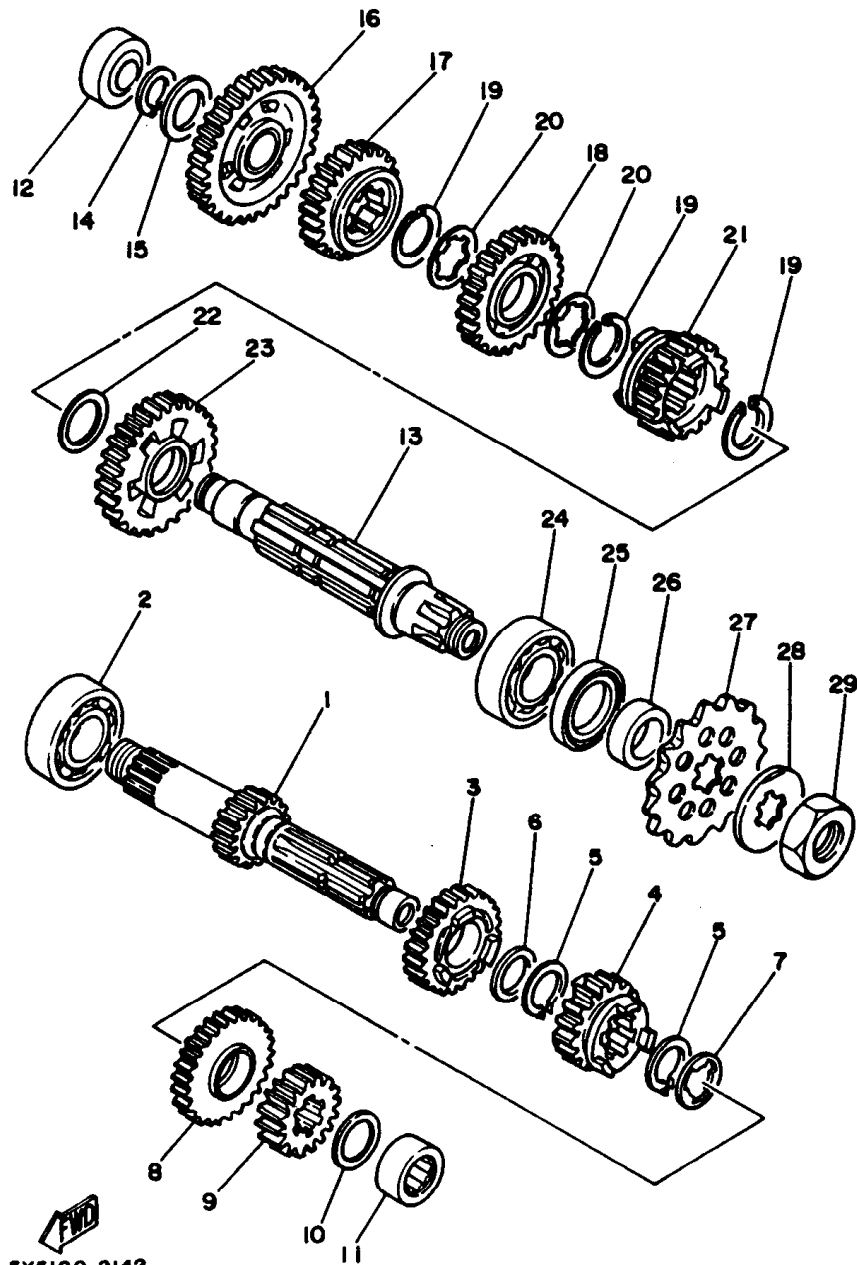
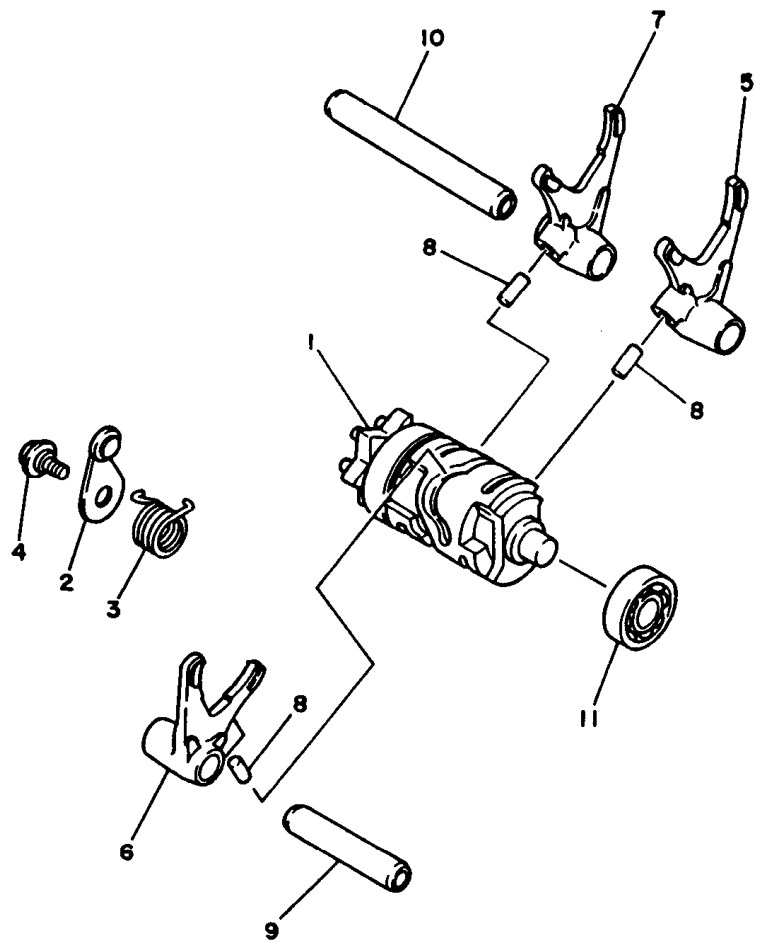

FIG. 13 TRANSMISSION

REF. NO.	PART NO.	DESCRIPTION	Q'TY	REMARKS
27	23X-17461-50	SPROCKET, drive (15T)	1	AP
28	90215-21239	WASHER, lock	1	
29	90179-20255	NUT	1	

FIG. 14 SHIFT CAM. FORK

REF. NO.	PART NO.	DESCRIPTION	Q'TY	REMARKS
1	24Y-18540-00	SHIFT CAM ASSY	1	
2	3R4-18140-00	STOPPER LEVER ASSY	1	
3	90508-26608	SPRING, torsion	1	
4	1W1-18177-00	BOLT, stopper	1	
5	5X5-18511-00	FORK, shift 1	1	
6	4V3-18512-00	FORK, shift 2	1	
7	5X5-18513-00	FORK, shift 3	1	
8	93606-14154	PIN, dowel	3	
9	5X5-18531-01	BAR, shift fork guide 1	1	
10	5X5-18535-01	BAR, shift fork guide 2	1	
11	93306-00106	BEARING	1	





24Y100-3150

C6

FIG. 15 SHIFT SHAFT

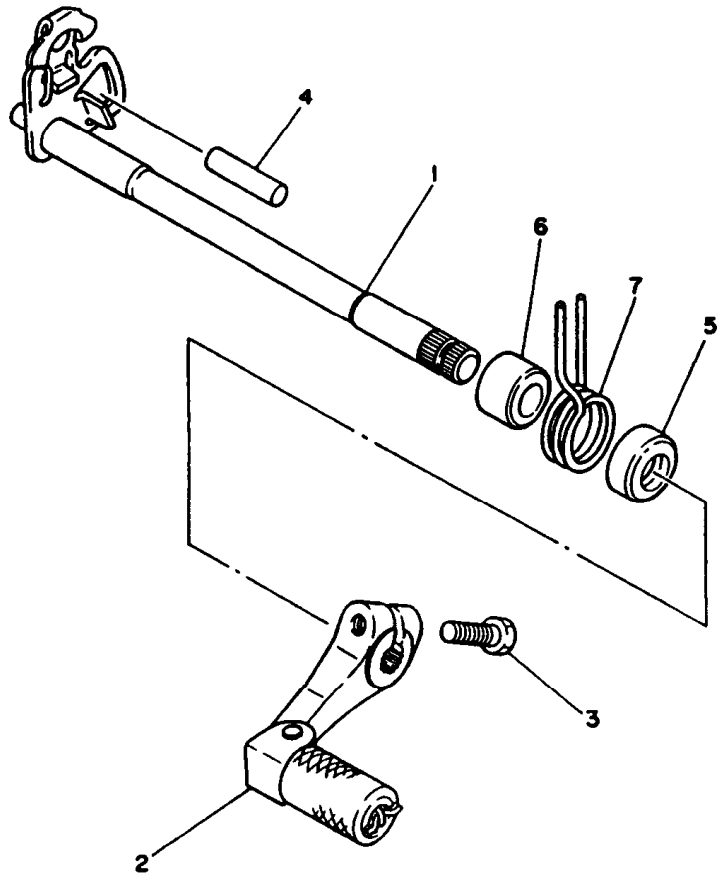
REF. NO.	PART NO.	DESCRIPTION	Q'TY	REMARKS
1	23X-18101-00	SHIFT SHAFT ASSY	1	
2	24Y-18110-00	SHIFT PEDAL ASSY	1	
3	97321-06025	BOLT	1	
4	93608-25150	PIN, dowel	1	
5	93102-12106	OIL SEAL	1	
6	90560-12171	SPACER	1	
7	90508-29361	SPRING, torsion	1	



24Y100-3160

C7

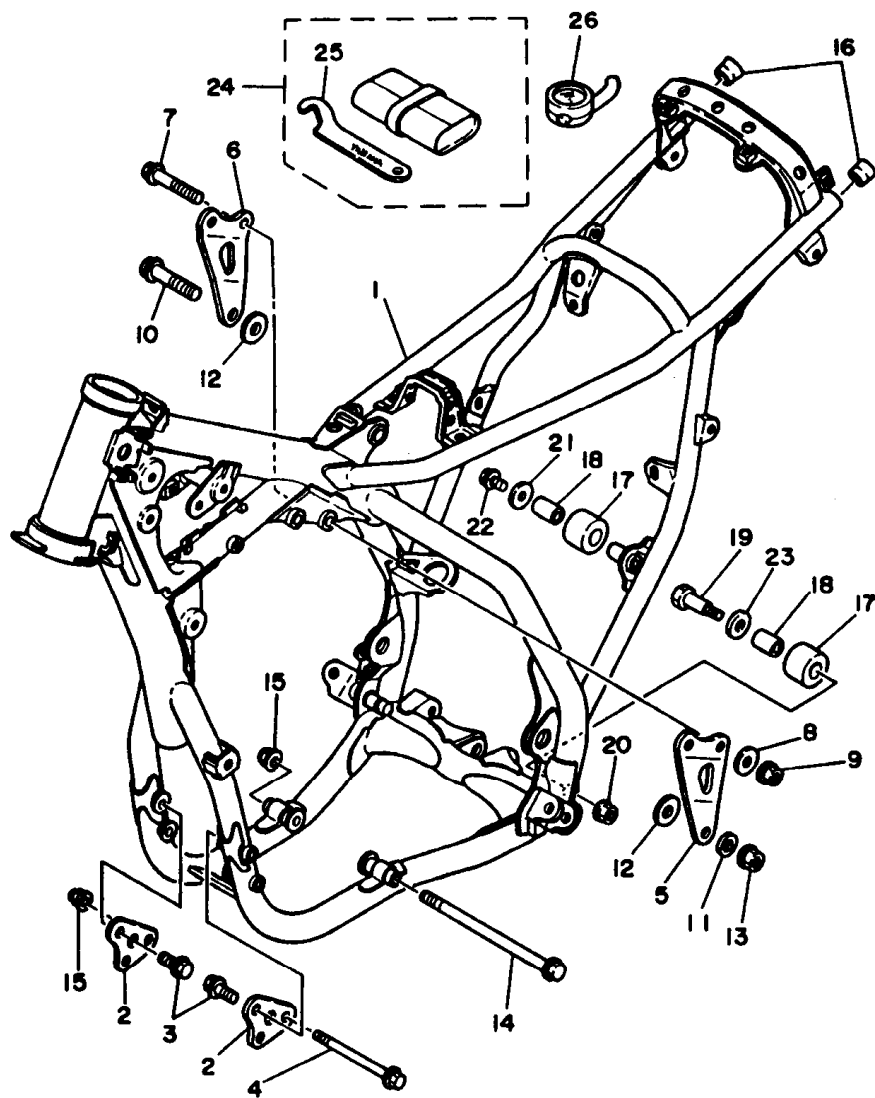

56A110-5160

FIG. 16 FRAME

REF. NO.	PART NO.	DESCRIPTION	Q'TY	REMARKS
1	56A-21110-00-FH	FRAME COMP.	1	fire red
2	24Y-21415-00	BRACKET, front upper 1	2	
3	95821-08020	BOLT, flange	4	
4	95811-08100	BOLT, flange	1	
5	39X-21425-00	BRACKET, rear upper 1	1	
6	39X-21426-00	BRACKET, rear upper 2	1	
7	95811-08055	BOLT, flange	2	
8	90202-08022	WASHER, plate	2	
9	90185-08113	NUT, self-locking	2	
10	95811-10055	BOLT, flange	1	
11	92901-10200	WASHER, plain	1	
12	90201-10139	WASHER, plate	2	
13	90179-10280	NUT	1	
14	95811-08180	BOLT, flange	1	
15	90185-08113	NUT, self-locking	2	
16	90339-13005	PLUG	2	
17	22W-22178-01	TENSIONER	2	
18	4V4-22184-00	BUSH	2	
19	90109-08705	BOLT	1	
20	90185-08106	NUT, self-locking	1	
21	90201-08753	WASHER, plate	1	
22	95802-08012	BOLT, flange	1	
23	90201-13202	WASHER, plate	1	
24	23X-28100-01	TOOL KIT	1	
25	23X-28135-00	.SPANNER, special	1	
26	2X4-2811A-00	GAUGE, air	1	

FIG. 17 FENDER

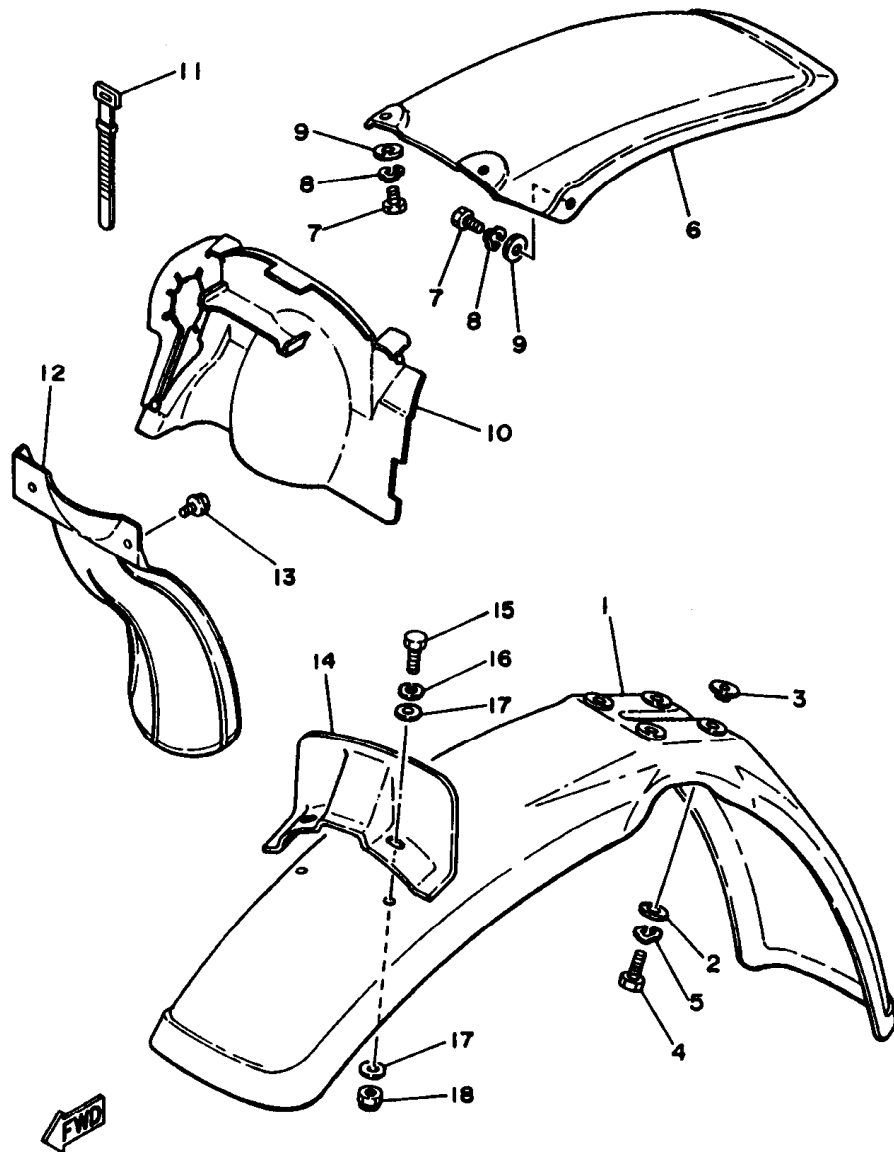

39X100-4171

REF. NO.	PART NO.	DESCRIPTION	Q'TY	REMARKS
1	5X6-21511-10	FENDER, front	1	white
2	90201-06571	WASHER, plate	4	
3	90387-06681	COLLAR	4	
4	97302-06020	BOLT	4	
5	92902-06700	WASHER	4	
6	3R4-21611-10	FENDER, rear	1	white
7	97301-06016	BOLT	4	
8	92902-06700	WASHER	4	
9	90201-06571	WASHER, plate	4	
10	39X-21620-00	MUD GUARD COMP.	1	
11	437-83936-00	BAND, switch cord	1	
12	39X-21642-00	GUARD, flap	1	
13	90119-06042	BOLT, with washer		
14	4V2-21543-01	PLATE 1	1	
15	97301-06020	BOLT	2	
16	92901-06100	WASHER, spring	2	
17	90201-06052	WASHER, plate	4	
18	95601-06100	NUT, u	2	

FIG. 18 SIDE COVER

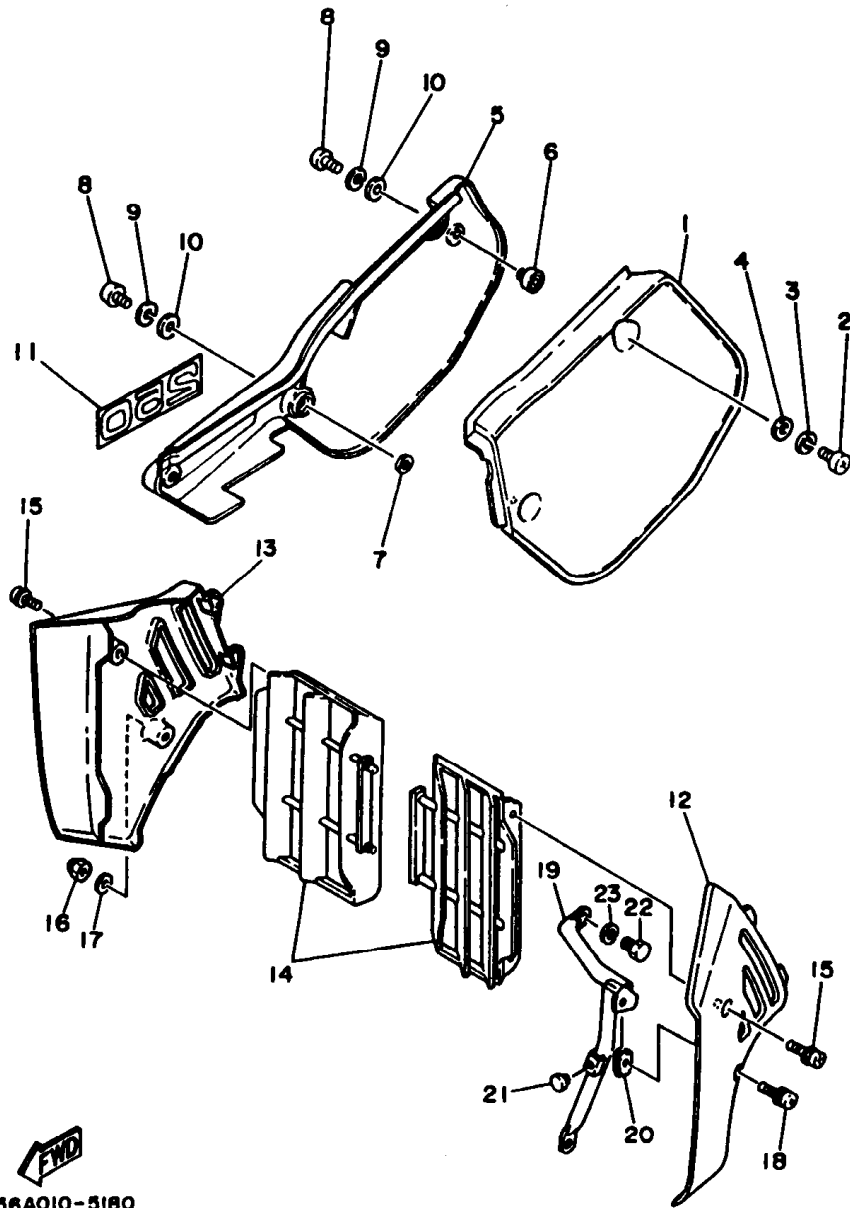

56A010-5180

REF. NO.	PART NO.	DESCRIPTION	Q'TY	REMARKS
1	39X-21711-10-98	COVER, side 1	1	low gloss black/white
2	92501-06014	SCREW, pan head	2	
3	92901-06100	WASHER, spring	2	
4	90201-06571	WASHER, plate	2	
5	39X-21721-10-98	COVER, side 2	1	low gloss black/white
6	22W-24181-00	DAMPER, locating 1	4	
7	92902-08200	WASHER	2	
8	92501-06014	SCREW, pan head	2	
9	92901-06100	WASHER, spring	2	
10	90201-06571	WASHER, plate	2	
11	39X-21737-10	EMBLEM	1	for w
12	39X-21731-10	COVER, side 3	1	chappy red
13	39X-21741-10	COVER, side 4	1	chappy red
14	24Y-2172A-00	PANEL 1	2	
15	90159-05100	SCREW, with washer	3	
16	95301-05800	NUT, crown	1	
17	90201-05029	WASHER, plate	1	
18	90159-05100	SCREW, with washer	2	
19	39X-2174F-00	GUARD, radiator	1	
20	22W-21791-00	NUT	1	
21	24X-12465-00	DAMPER, radiator	1	
22	97301-08016	BOLT	2	
23	92901-08100	WASHER, spring	2	

FIG. 19 REAR ARM

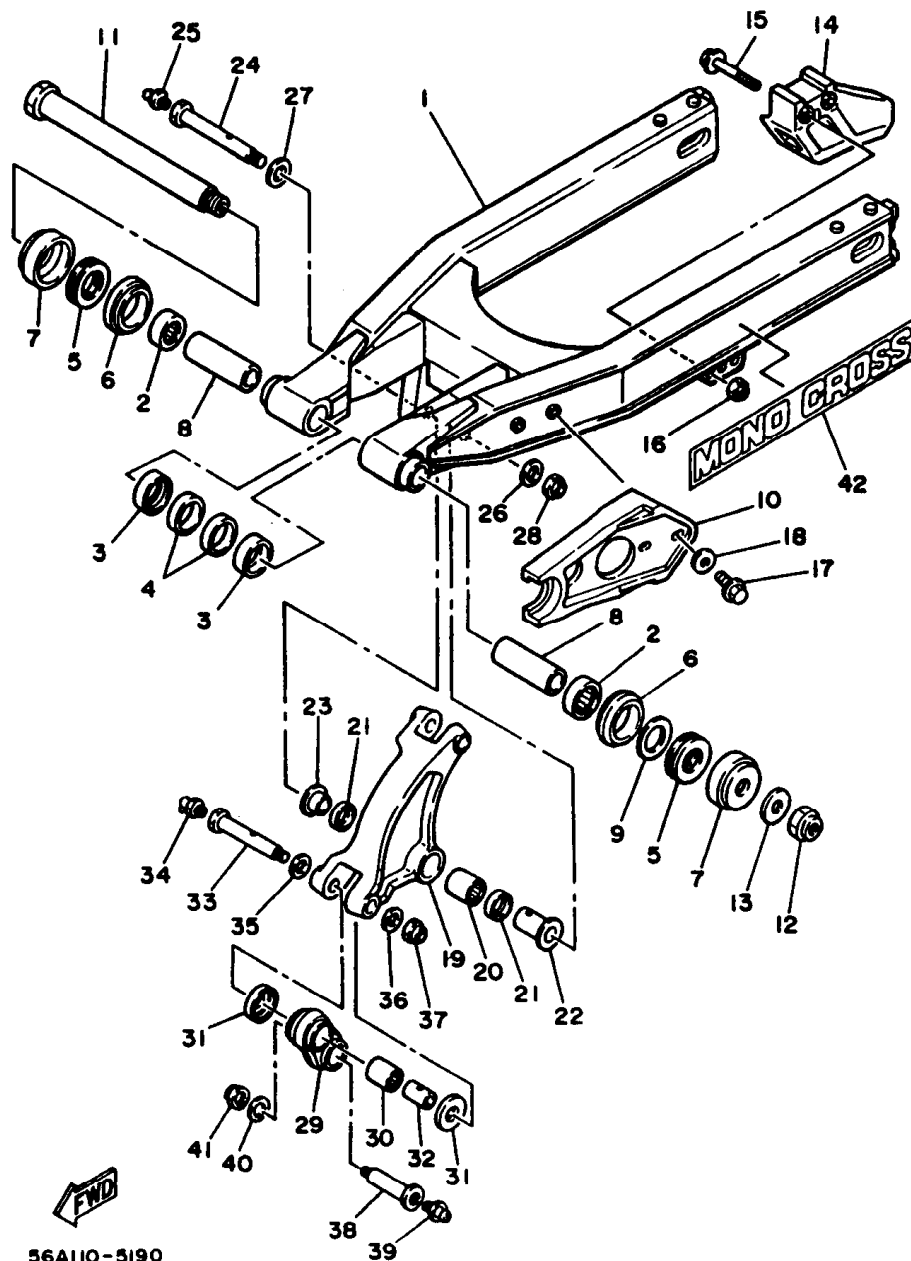

56A110-5190

REF. NO.	PART NO.	DESCRIPTION	Q'TY	REMARKS
1	56A-22110-00	REAR ARM COMP.	1	
2	93317-32231	BEARING, cylindrical	2	
3	90380-22111	BUSH, solid	2	
4	93106-22019	OIL SEAL	2	
5	93342-22208	BEARING	2	
6	93108-35004	OIL SEAL	2	
7	3R4-22129-00	COVER, thrust 2	2	
8	90380-16077	BUSH, solid	2	
9	156-22127-00	SHIM (0.3T)	1 UN	
10	39W-22151-00	SEAL, guard	1	
11	5X6-22141-01	SHAFT, pivot	1	
12	90185-16127	NUT, self-locking	1	
13	90201-160F6	WASHER, plate	1	
14	23X-22199-10	SUPPORT, chain	1	
15	95802-08055	BOLT, flange	2	
16	90185-08106	NUT, self-locking	2	
17	95801-06020	BOLT, flange	2	
18	90201-06067	WASHER, plate	2	
19	39X-2217A-00	ARM, relay	1	
20	93317-32034	BEARING, cylindrical	1	
21	93109-20029	OIL SEAL	2	
22	90387-147G6	COLLAR	1	
23	90387-147G7	COLLAR	1	
24	90109-12701	BOLT	1	
25	93700-06004	NIPPLE, grease	1	
26	90201-120A5	WASHER, plate	1	
27	90201-14222	WASHER, plate	1	
28	90185-12119	NUT, self-locking	1	

C11

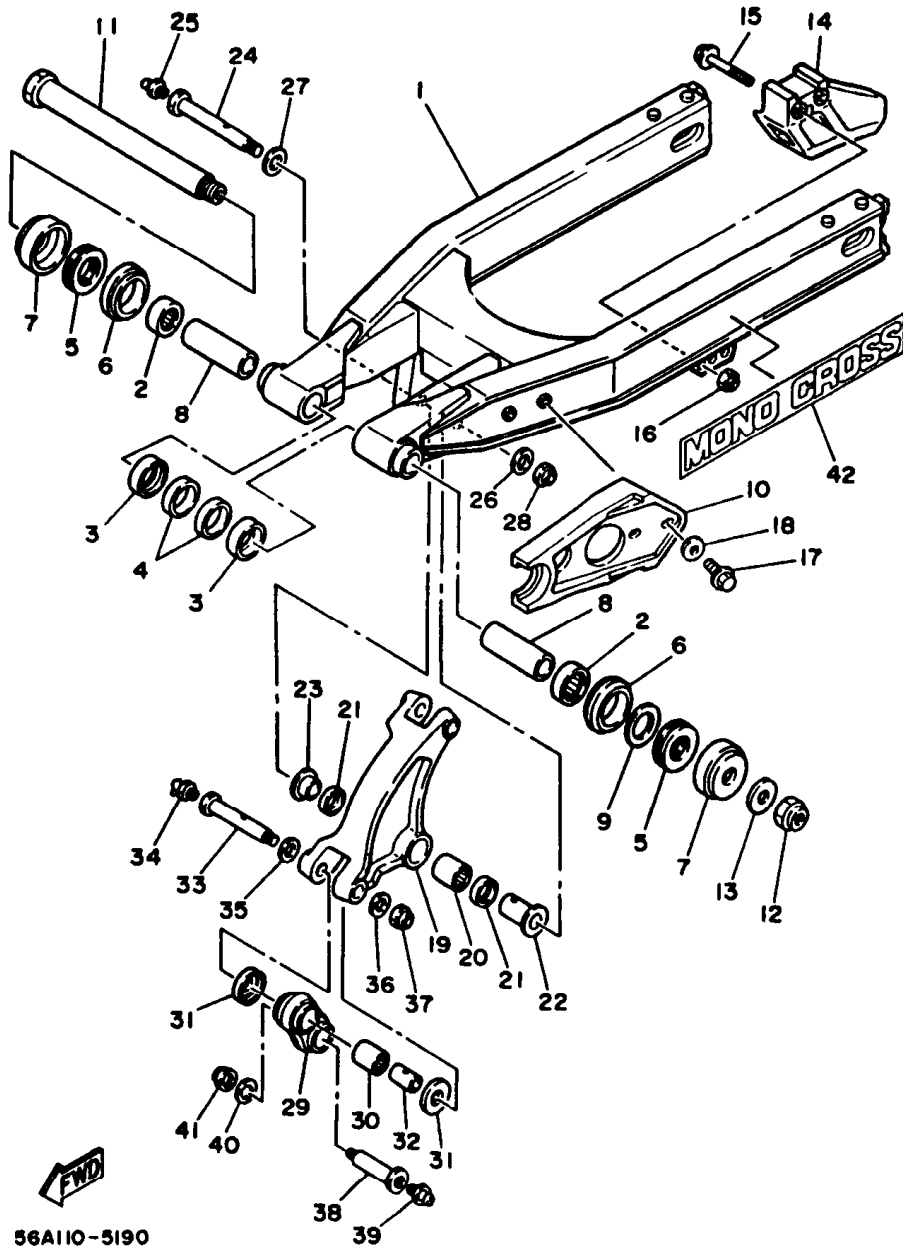

56A110-5190

FIG. 19 REAR ARM

REF. NO.	PART NO.	DESCRIPTION	Q'TY	REMARKS
29	39X-2217F-00	ROD, connecting 1	1	
30	93315-31732	BEARING, cylindrical	2	
31	23X-22129-00	COVER, thrust 2	4	
32	90387-121H1	COLLAR	2	
33	90109-10702	BOLT	1	
34	93700-06005	NIPPLE, grease	1	
35	90201-120E6	WASHER, plate	1	
36	90201-100E9	WASHER, plate	1	
37	90185-10120	NUT, self-locking	1	
38	90109-10703	BOLT	1	
39	93700-06004	NIPPLE, grease	1	
40	90201-10430	WASHER, plate	1	
41	95611-10100	NUT, u	1	
42	5X3-2218A-00	EMBLEM, rear arm	2	

FIG. 20 REAR SUSPENSION

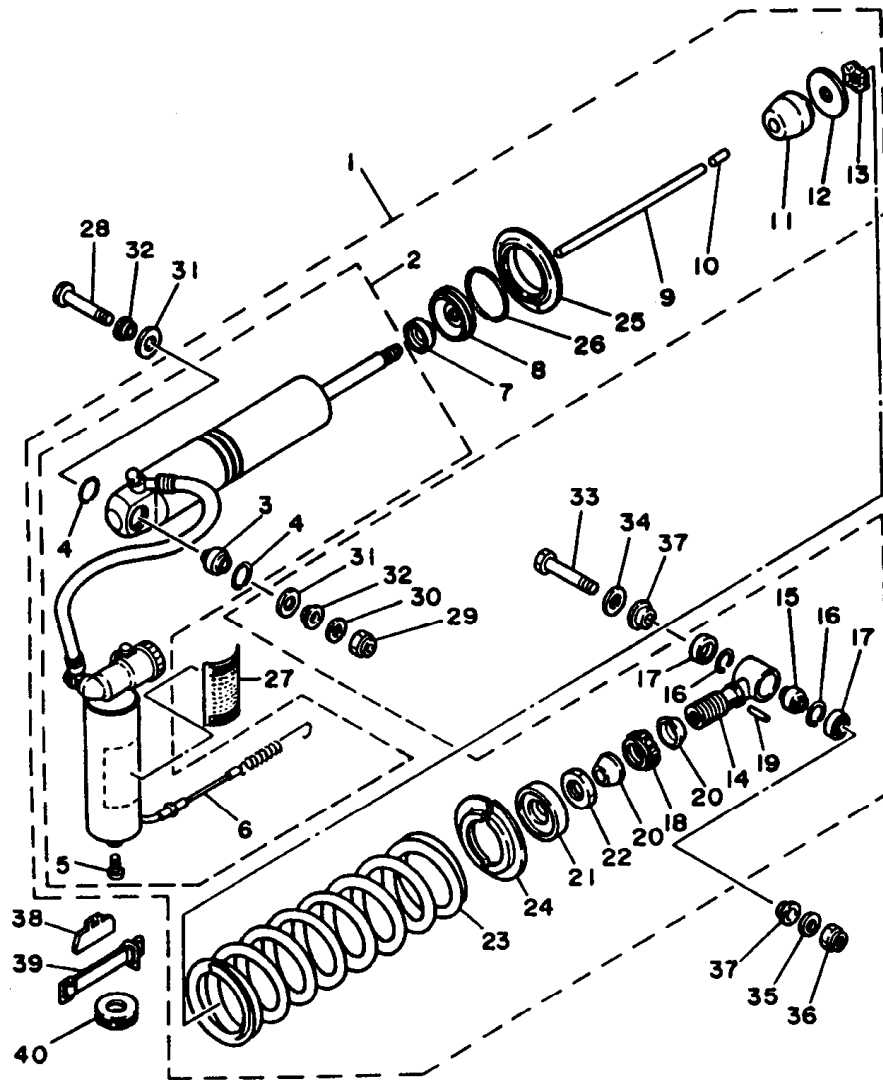

REF. NO.	PART NO.	DESCRIPTION	Q'TY	REMARKS
1	56A-22210-10-6W	SHOCK ABSORBER ASSY, rear	1	native red
2	56A-22401-00	.DAMPER SUB ASSY	1	
3	93399-99916	..BEARING	1	
4	93440-30113	..CIRCLIP	2	
5	98501-04006	..SCREW, pan head	1	
6	56A-22463-00	..CABLE, control l	1	
7	23X-22475-00	..SEAL, dust	1	
8	26A-22472-00	..CAP, case	1	
9	56A-22489-00	..ROD, push	1	
10	93604-21193	..PIN, dowel	1	
11	39X-22493-00	..BUMP, stop	1	
12	3R4-22228-00	..SUPPORT, bump stop	1	
13	90206-14067	..WASHER, wave	1	
14	39X-22409-00	..UPPER BRACKET SUB ASSY	1	
15	93399-99916	..BEARING	1	
16	93440-30113	..CIRCLIP	2	
17	93104-18077	..OIL SEAL	2	
18	5X3-22497-00	..NUT, adjusting	1	
19	93604-26132	..PIN, dowel	1	
20	3R4-22221-01	..COVER	2	
21	23X-22213-00	..SEAT, spring upper	1	
22	90170-20213	..NUT	1	
23	39X-22212-10-6W	..SPRING (K=4.25)	1	native red
24	23X-22214-00	..GUIDE, spring l	2	
25	23X-22223-00	..SEAT, spring lower	1	
26	93440-51103	..CIRCLIP	1	
27	56A-22499-10	..LABEL, caution	1	
28	90109-10704	BOLT	1	

FWD
56A110-3200

FIG. 20 REAR SUSPENSION

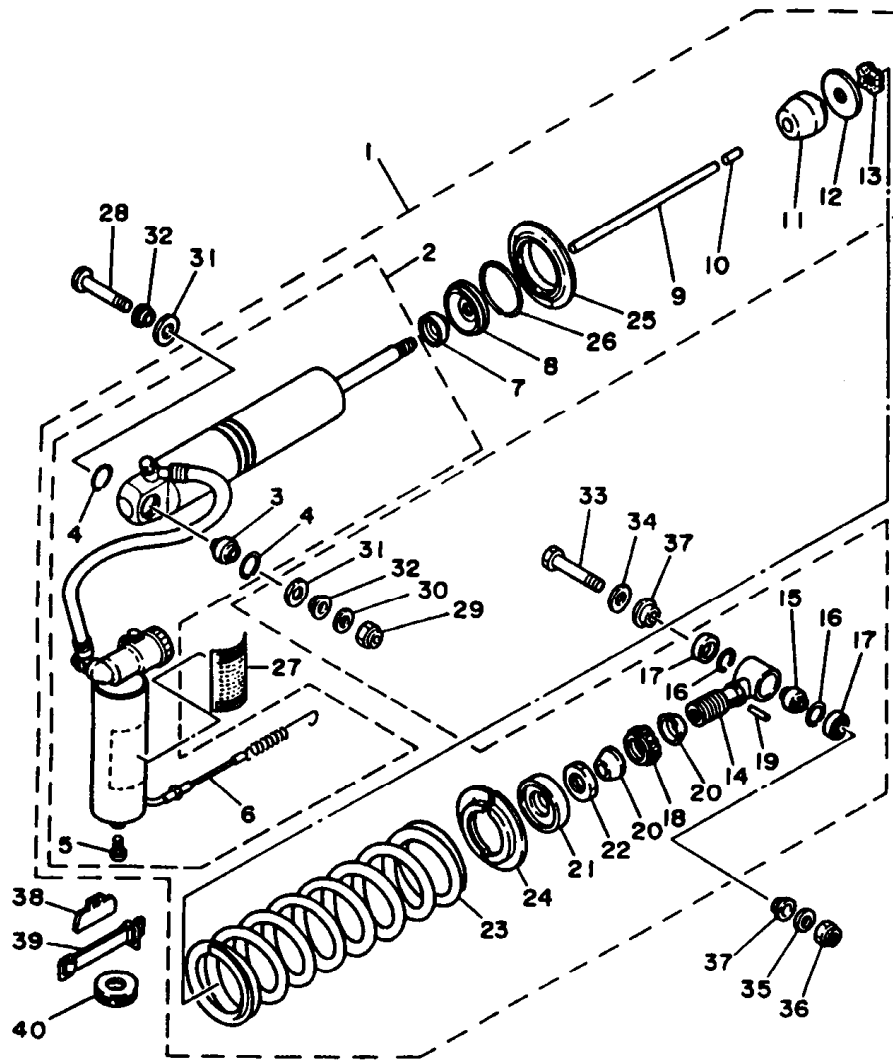

REF. NO.	PART NO.	DESCRIPTION	Q'TY	REMARKS
29	90185-10120	NUT, self-locking	1	
30	90201-10430	WASHER, plate	1	
31	23X-22211-00	COVER	2	
32	90387-127G8	COLLAR	2	
33	90109-10700	BOLT	1	
34	90201-120E6	WASHER, plate	1	
35	90201-100E9	WASHER, plate	1	
36	90185-10120	NUT, self-locking	1	
37	90387-126H8	COLLAR	2	
38	56A-22261-00	DAMPER, sub tank	1	
39	24X-22262-00	HOLDER, sub tank	1	
40	90480-25381	GROMMET	1	



56A110-5200

C14

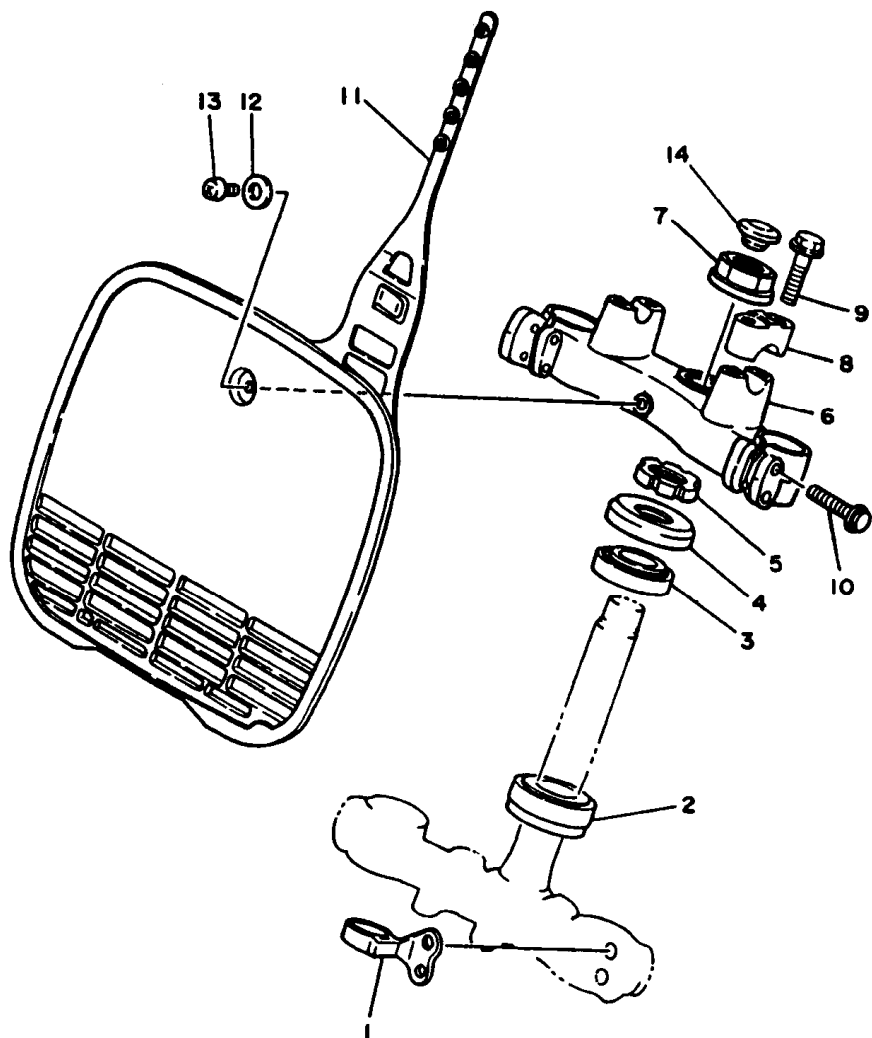

FIG. 21 STEERING

REF. NO.	PART NO.	DESCRIPTION	Q'TY	REMARKS
1	3R4-23389-00	GUIDE, cable	1	
2	93332-00008	BEARING	1	
3	93332-00023	BEARING	1	
4	1W1-23416-00	COVER, ball race 2	1	
5	90179-25033	NUT	1	
6	39W-23435-00-98	CROWN, handle	1	low gloss black
7	90179-22330	NUT	1	
8	1E6-23441-00	HOLDER, handle upper	2	
9	95821-08035	BOLT, flange	4	
10	95821-08040	BOLT, flange	4	
11	24X-23485-10	PLATE, number	1	white
12	90201-06571	WASHER, plate	1	
13	92501-06012	SCREW, pan head	1	
14	34K-2319U-00	CAP	1	



43NO10-4210

C15

FIG. 22 FRONT FORK

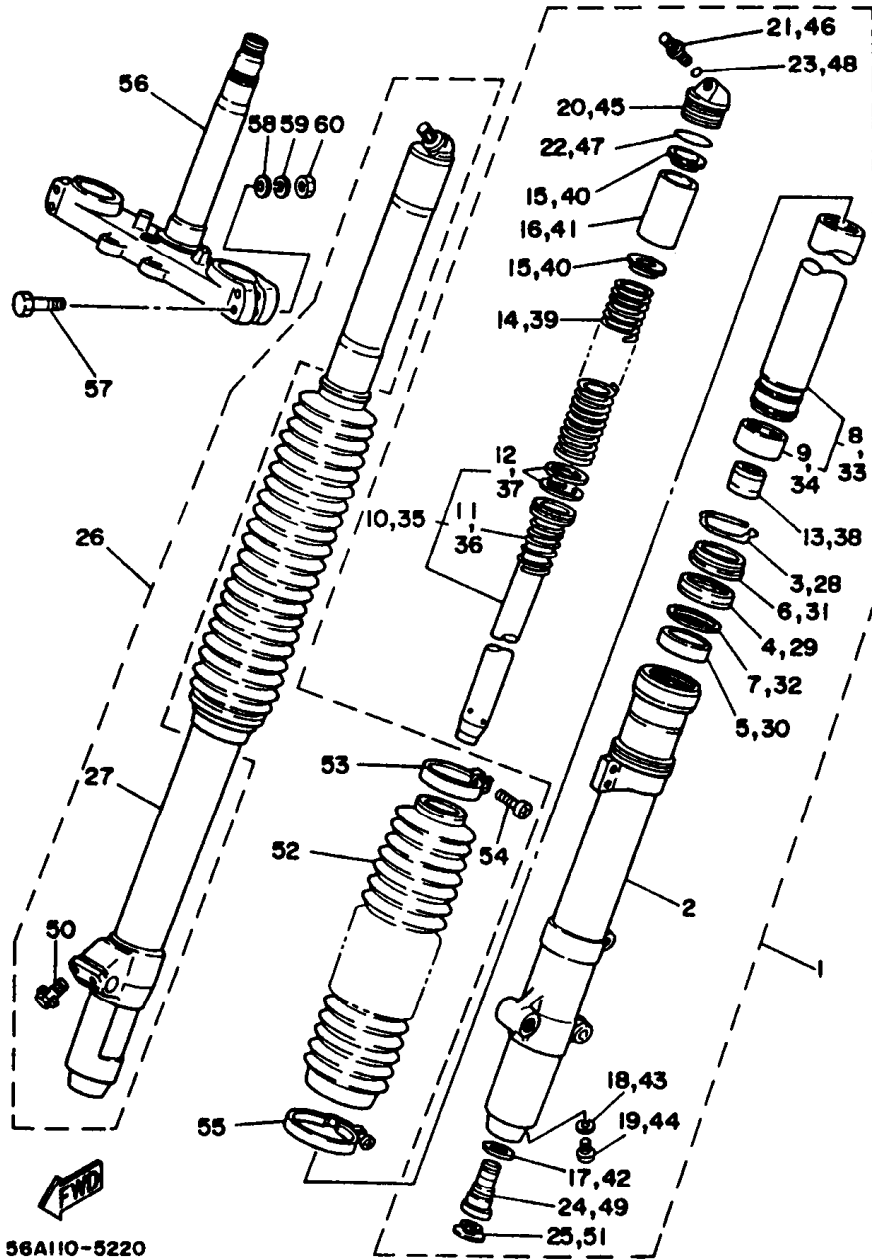

56A110-5220

REF. NO.	PART NO.	DESCRIPTION	Q'TY	REMARKS
1	56A-23102-M0	FRONT FORK ASSY (L.H)	1	
2	56A-23126-L0	.TUBE, outer 1	1	
3	4V4-23153-L0	.RING, snap	1	
4	23X-23145-L0	.OIL SEAL	1	
5	4V4-23125-L0	.METAL, slide 1	1	
6	23X-23144-L0	.SEAL, dust	1	
7	4V4-23146-L0	.WASHER, oil seal	1	
8	56A-23110-M0	.INNER TUBE COMP.1	1	
9	4V4-23171-L0	..PISTON, front fork	1	
10	56A-23170-M0	.CYLINDER COMP., front fork	1	
11	55Y-23152-M0	..SPRING, sub	1	
12	4V4-23157-L0	..RING, piston	2	
13	23X-23173-L0	.SPINDLE, taper	1	
14	39X-23141-00	.SPRING, front fork (K=0.305)	1	
15	4V4-23142-L0	.SEAT, spring upper	2	
16	5X6-23118-10	.SPACER (L=80)	1	
17	23X-23158-L0	.GASKET	1	
18	122-23129-00	.GASKET, drain plug	1	
19	4H7-23119-00	.PLUG, drain	1	
20	43M-23111-L0	.BOLT, cap	1	
21	23X-23190-L0	.AIR VALVE COMP.	1	
22	4V4-23188-L0	.O-RING	1	
23	3J2-23147-00	.O-RING	1	
24	56A-2316A-M0	.VALVE COMP.	1	
25	55Y-2312G-M0	.PLUG	1	
26	56A-23103-M0	FRONT FORK ASSY (R.H)	1	
27	56A-23136-L0	.TUBE, outer 2	1	
28	4V4-23153-L0	.RING, snap	1	

D2

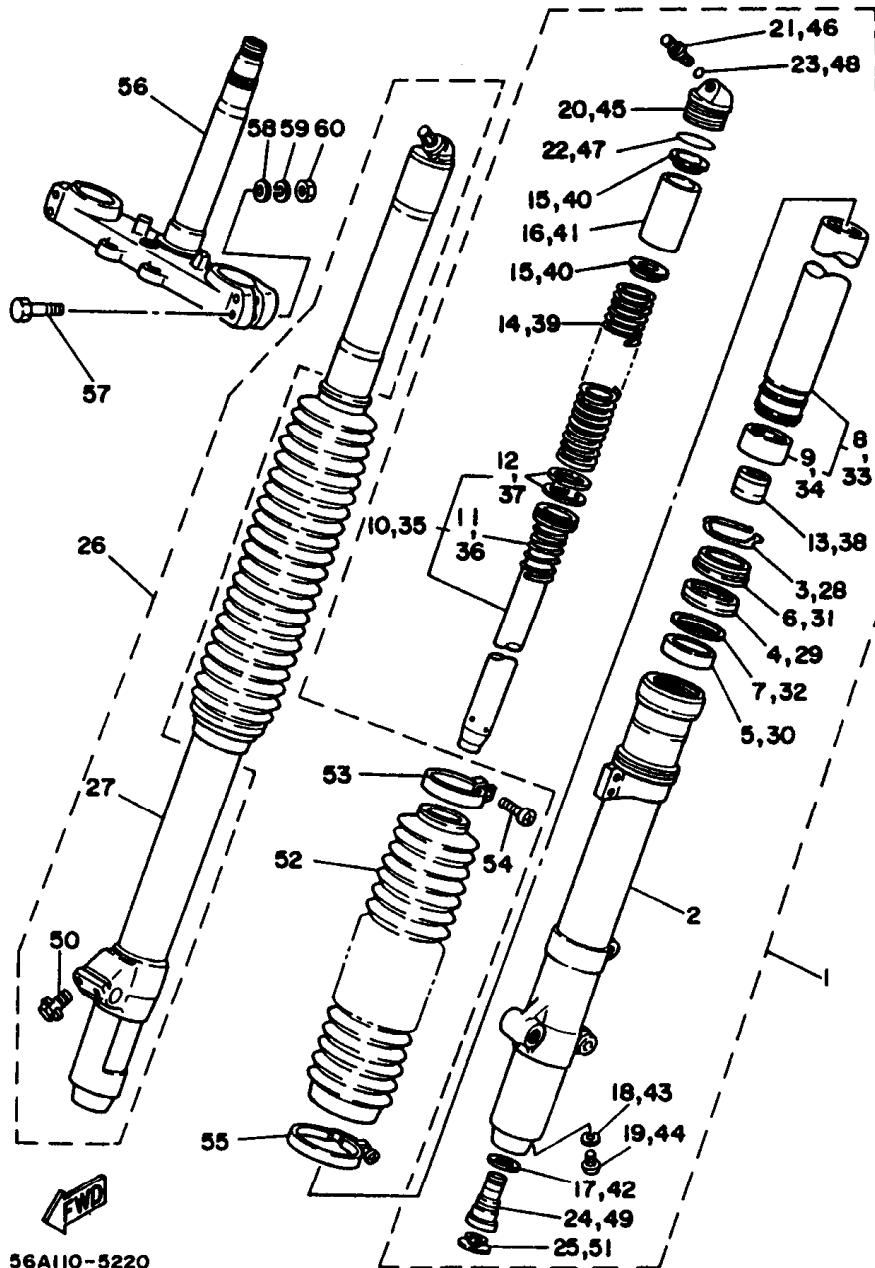

56A110-5220

FIG. 22 FRONT FORK

REF. NO.	PART NO.	DESCRIPTION	Q'TY	REMARKS
29	23X-23145-LO	.OIL SEAL	1	
30	4V4-23125-LO	.METAL, slide 1	1	
31	23X-23144-LO	.SEAL, dust	1	
32	4V4-23146-LO	.WASHER, oil seal	1	
33	56A-23110-MO	.INNER TUBE COMP.1	1	
34	4V4-23171-LO	..PISTON, front fork	1	
35	56A-23170-MO	.CYLINDER COMP., front fork	1	
36	55Y-23152-MO	..SPRING, sub	1	
37	4V4-23157-LO	..RING, piston	2	
38	23X-23173-LO	.SPINDLE, taper	1	
39	39X-23141-00	.SPRING, front fork (K=0.305)	1	
40	4V4-23142-LO	.SEAT, spring upper	2	
41	5X6-23118-10	.SPACER (L=80)	1	
42	23X-23158-LO	.GASKET	1	
43	122-23129-00	.GASKET, drain plug	1	
44	4H7-23119-00	.PLUG, drain	1	
45	43M-23111-LO	.BOLT, cap	1	
46	23X-23190-LO	.AIR VALVE COMP.	1	
47	4V4-23188-LO	.O-RING	1	
48	3J2-23147-00	.O-RING	1	
49	56A-2316A-MO	.VALVE COMP.	1	
50	5X6-23181-LO	.BOLT, hexagon socket head	1	
51	55Y-2312G-MO	.PLUG	1	
52	43M-23191-LO	BOOT	2	red
53	43M-23192-LO	BAND	2	
54	98506-04018	SCREW, pan head	2	
55	43M-23489-LO	BAND	2	
56	39X-23340-00	UNDER BRACKET COMP.	1	

D3

FIG. 22 FRONT FORK

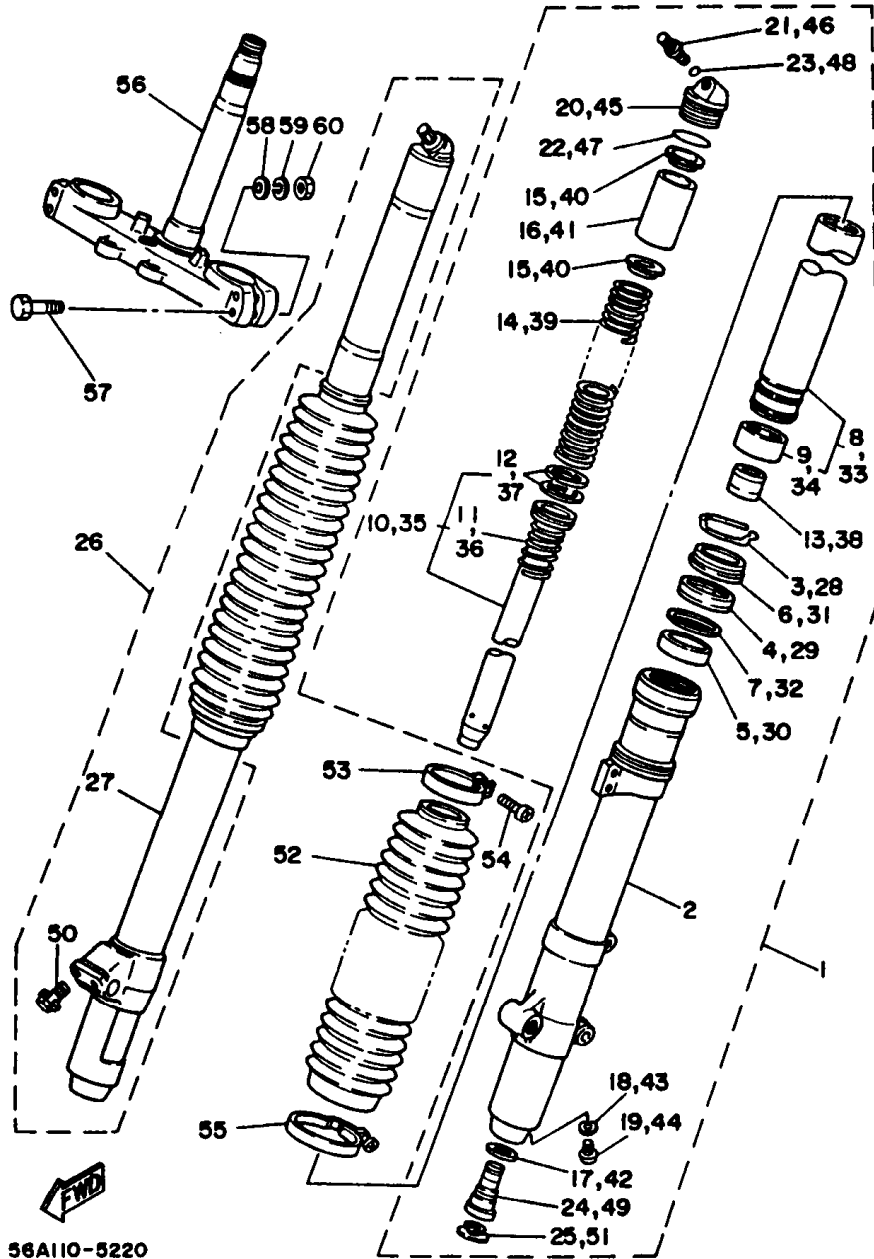

56A110-5220

REF. NO.	PART NO.	DESCRIPTION	Q'TY	REMARKS
57	90109-08397	BOLT	4	
58	90201-08544	WASHER, plate	4	
59	92901-08100	WASHER, spring	4	
60	95311-08600	NUT	4	

D4

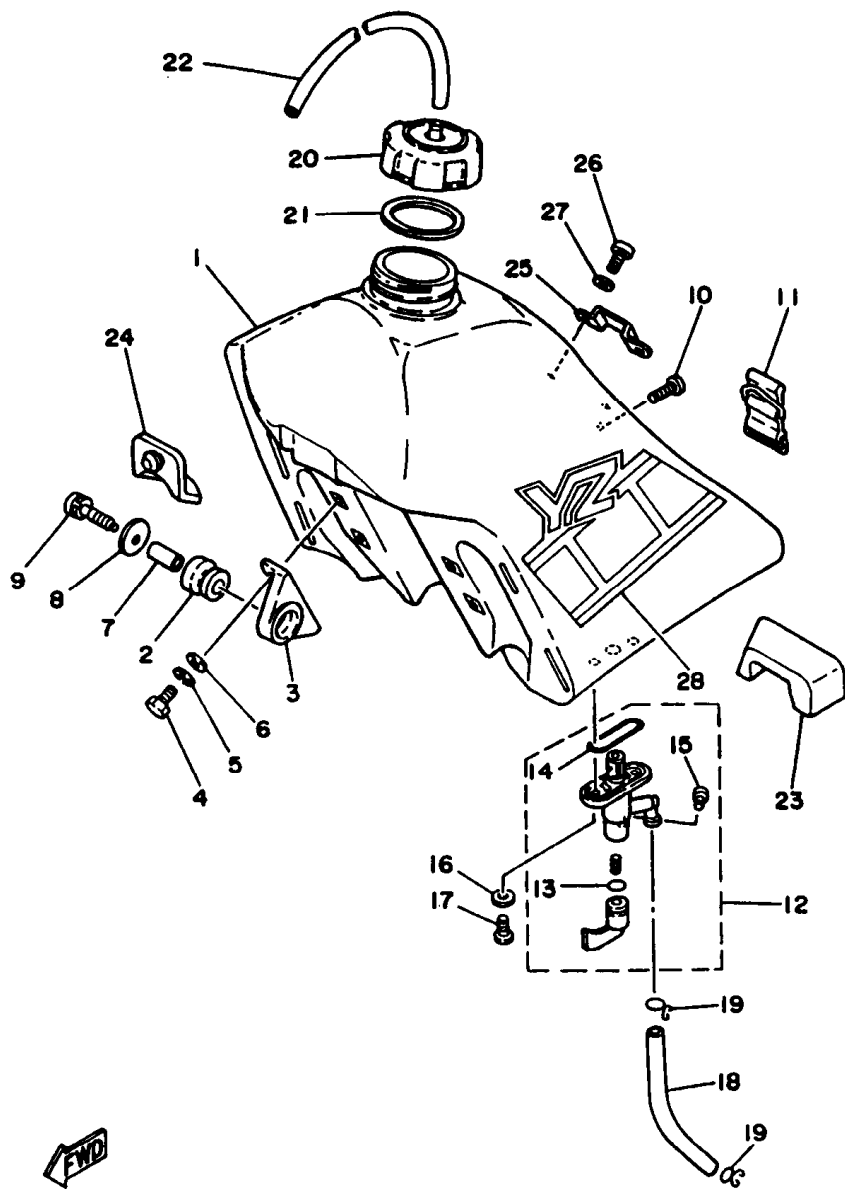

56A110-5230

FIG. 23 FUEL TANK

REF. NO.	PART NO.	DESCRIPTION	Q'TY	REMARKS
1	39X-24110-10	FUEL TANK COMP.	1	white
2	90480-18354	GROMMET	2	
3	24X-24144-00	HOLDER, damper	2	
4	97301-06016	BOLT	4	
5	92901-06100	WASHER, spring	4	
6	90201-061A5	WASHER, plate	4	
7	90387-06387	COLLAR	1	
8	90201-06069	WASHER, plate	2	
9	90119-06073	BOLT, with washer	2	
10	98902-06018	SCREW, bind	1	
11	3R3-24173-00	BAND, tank fitting 1	1	
12	2K5-24500-00	FUEL COCK ASSY 1	1	
13	214-24512-00	.GASKET	1	
14	1A0-24512-00	.O-RING	1	
15	619-24535-00	.SCREW, lever fitting	1	
16	90202-06010	WASHER, plate	2	
17	90149-06011	SCREW	2	
18	90445-11356	HOSE	1	
19	90467-10008	CLIP	2	
20	5X7-24611-01	BODY, cap	1	
21	5X7-24612-00	GASKET, cap	1	
22	90445-09300	HOSE	1	
23	39X-24181-00	DAMPER, locating 1	1	
24	23X-24184-00	DAMPER, locating 4	1	
25	5X6-2412F-00	BRACKET, seat	1	
26	92501-06012	SCREW, pan head	2	
27	90201-061A5	WASHER, plate	2	
28	56A-24250-10	GRAPHIC SET	1	

D5

FIG. 24 SEAT

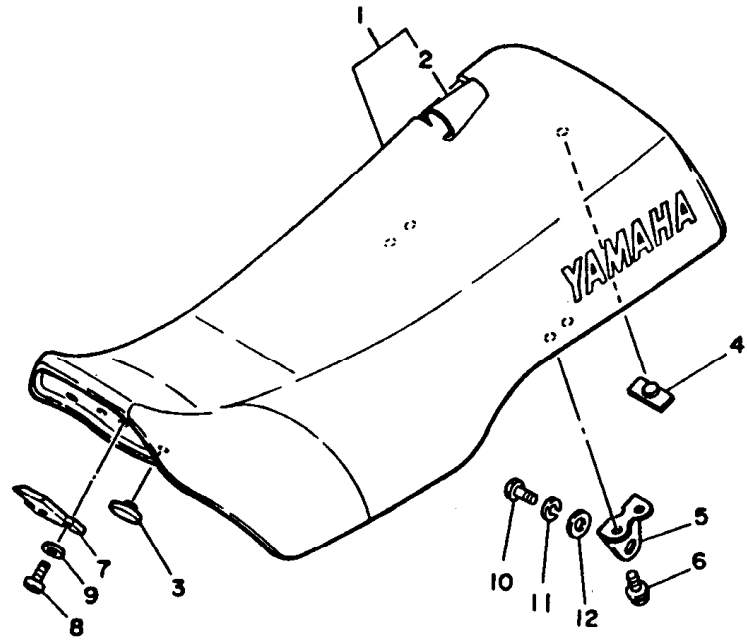

REF. NO.	PART NO.	DESCRIPTION	Q'TY	REMARKS
1	39X-W2473-20	SEMI-DOUBLE SEAT ASSY	1	red
2	23X-24731-20	.COVER, seat	1	
3	22W-24741-00	PAD, seat	2	
4	509-24724-00	DAMPER, seat	1	
5	39W-24738-00	BRACKET, seat	2	
6	95801-06012	BOLT, flange	4	
7	5X6-24748-10	BRACKET, seat	1	
8	97301-06012	BOLT	2	
9	90201-061A5	WASHER, plate	2	
10	97301-08016	BOLT	2	
11	92901-08100	WASHER, spring	2	
12	90201-087F0	WASHER, plate	2	



43N010-4241

D6

FIG. 25 FRONT WHEEL

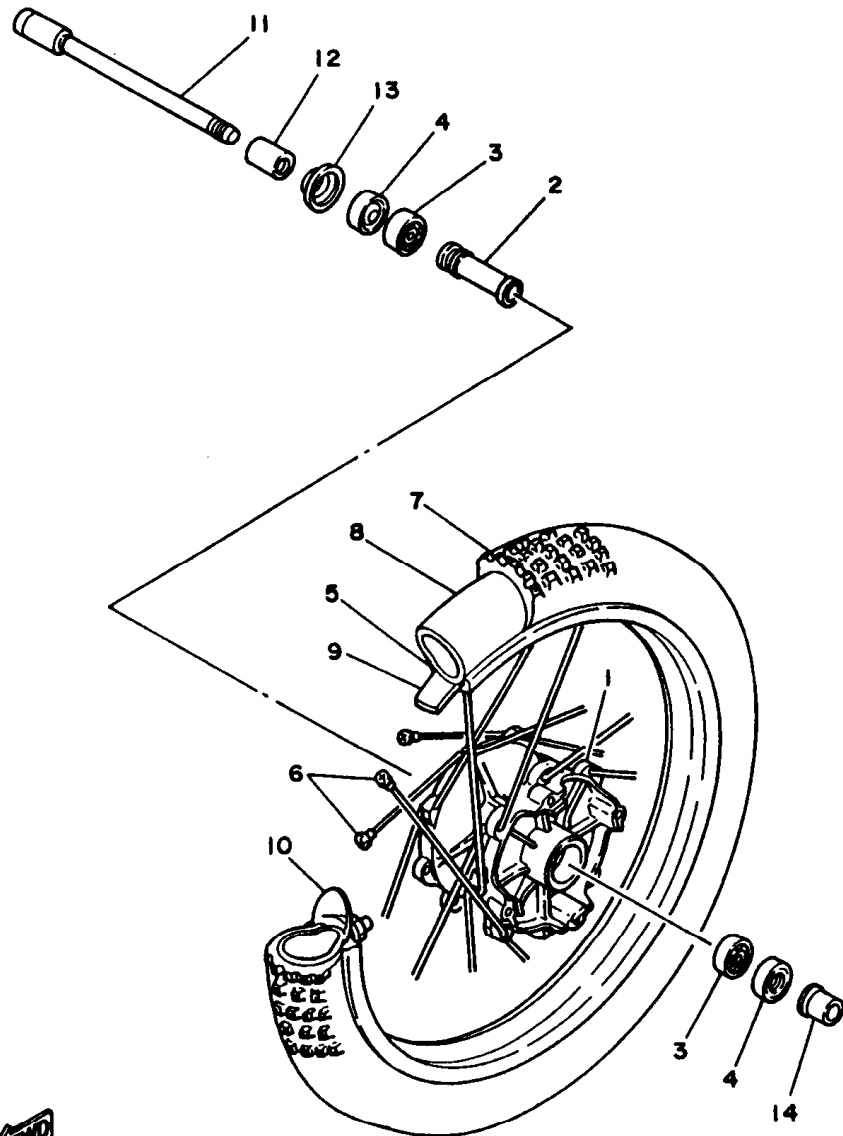

REF. NO.	PART NO.	DESCRIPTION	Q'TY	REMARKS
1	56A-25111-00-98	HUB, front	1	low gloss black
2	90560-15227	SPACER	1	
3	93306-20205	BEARING (B6202)	2	
4	93106-20021	OIL SEAL	2	
5	94416-21412	RIM (1.60-21)	1	
6	56A-25104-00	SPOKE SET, front	1	
7	94109-212G4	TIRE	1	bridgestone
8	94209-21229	TUBE	1	bridgestone
9	94330-21084	BAND, rim (3.00-21)	1	bridgestone
10	4V5-25194-00	SPACER, bead	1	
11	3R4-25181-01	AXLE, wheel	1	
12	90387-15535	COLLAR	1	
13	322-25118-00	COVER, hub dust	1	
14	90387-157L9	COLLAR	1	



56A110-5250

D7

FIG. 26 Front Brake Caliper

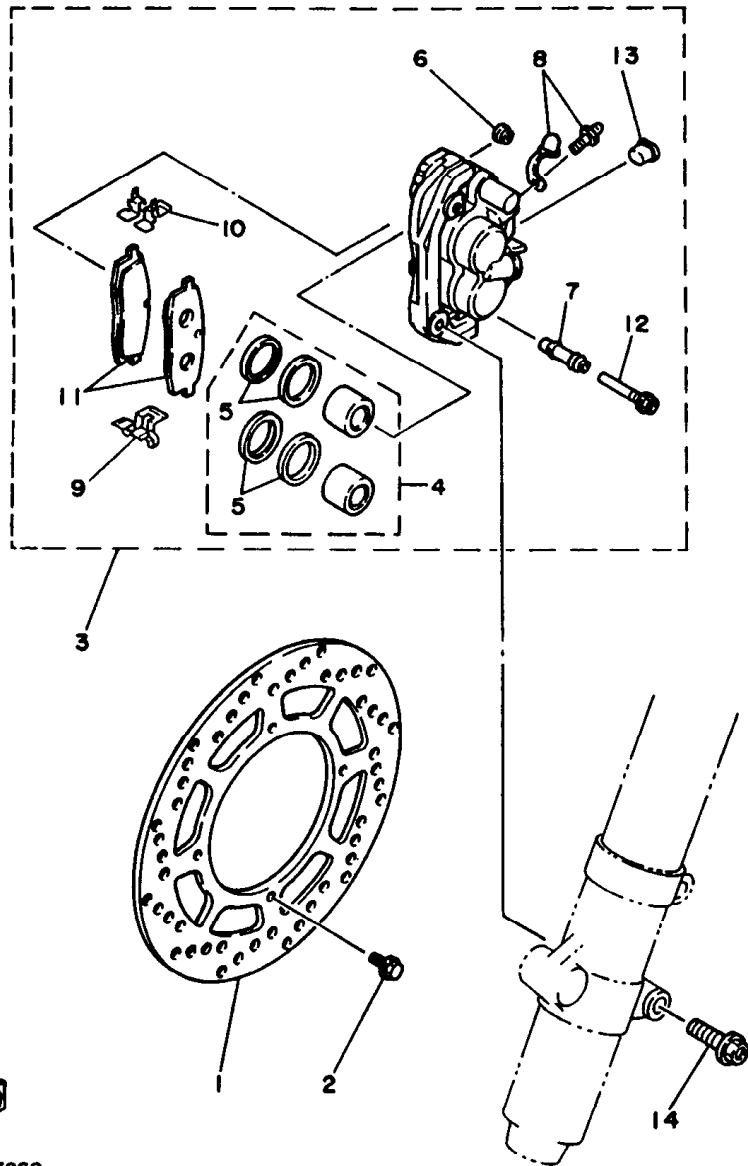

REF. NO.	PART NO.	DESCRIPTION	Q'TY	REMARKS
1	56A-25831-00	DISC, brake (RIGHT)	1	
2	90109-06757	BOLT	4	
3	56A-25810-00	CALIPER ASSY (RIGHT)	1	
4	56A-W0057-00	.PISTON ASSY, caliper	1	
5	56A-W0047-00	..CALIPER SEAL KIT	1	
6	5R2-25197-00	.BOOT	1	
7	56A-25937-00	.BOOT 2	1	
8	51L-W0048-00	.BREED SCREW KIT	1	
9	56A-25919-00	.SUPPORT, pad	1	
10	56A-25919-10	.SUPPORT, pad	1	
11	56A-W0046-00	.BRAKE PAD KIT, rear	1	
12	56A-25926-00	.BOLT	1	
13	34X-25845-00	.CAP, indicator	1	
14	95811-08040	BOLT, flange	2	

56A110-5260

D8

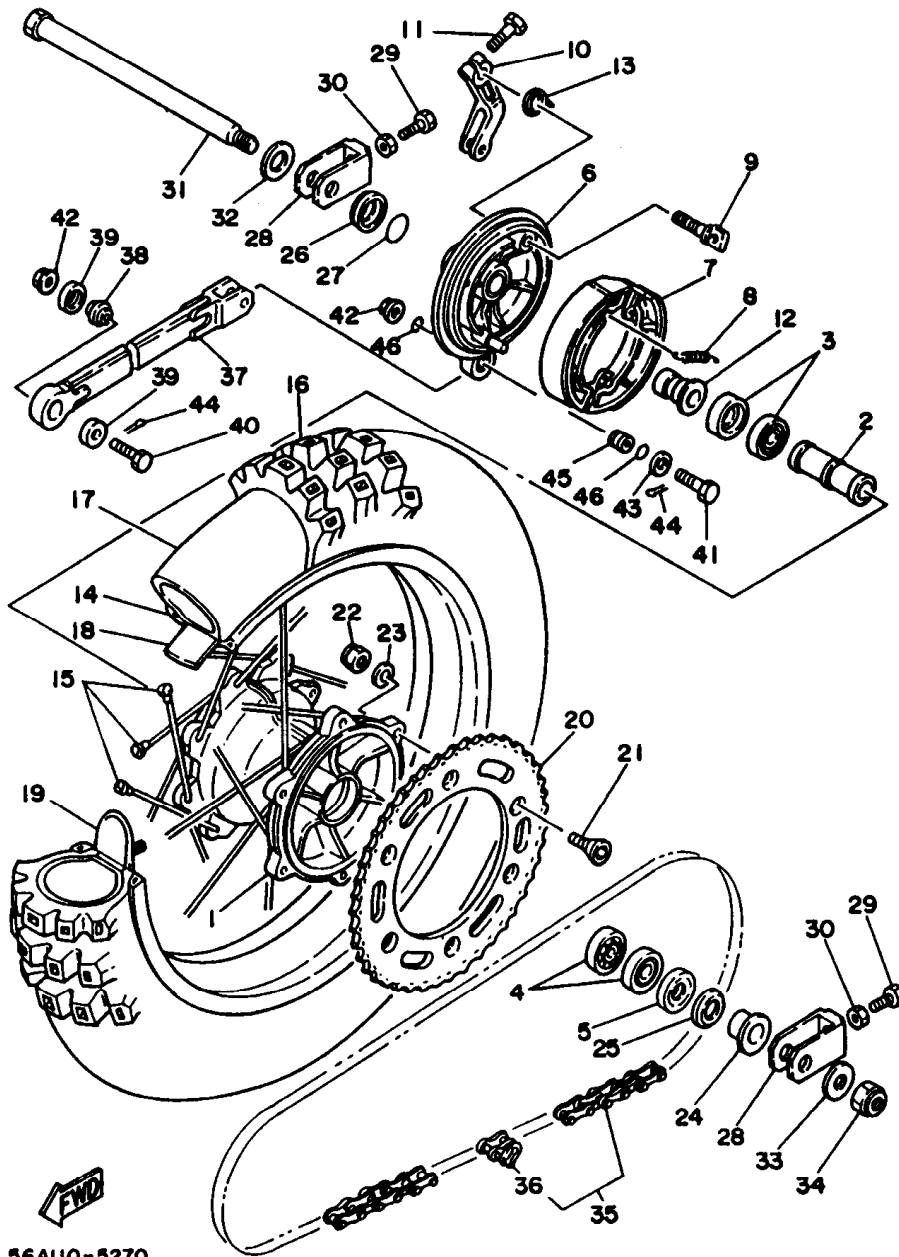

56A110-5270

FIG. 27 REAR WHEEL

REF. NO.	PART NO.	DESCRIPTION	Q'TY	REMARKS
1	56A-25311-00-98	HUB, rear	1	low gloss black
2	90560-20226	SPACER	1	
3	93306-00430	BEARING	2	
4	93306-00406	BEARING (B6004Z)	2	
5	93106-28023	OIL SEAL	1	
6	23X-25321-00-98	PLATE, brake shoe	1	low gloss black
7	23X-25330-00	BRAKE SHOE COMP.	2	
8	90506-17328	SPRING, tension	2	
9	39X-25351-00	CAMSHAFT	1	
10	5X4-25355-00	LEVER, camshaft	1	
11	90101-06291	BOLT	1	
12	90387-200H1	COLLAR	1	
13	90508-29596	SPRING, torsion	1	
14	94421-18414	RIM (2.15-18)	1	
15	56A-25304-00	SPOKE SET, rear	1	
16	94113-182G3	TIRE	1	bridgestone
17	94213-18232	TUBE	1	bridgestone
18	94340-18086	BAND, rim (4.00-18)	1	bridgestone
19	39X-25394-00	SPACER, bead	2	
20	3R4-25450-00	SPROCKET, driven (50T)	1	STD
	3R4-25444-01	SPROCKET, driven (44T)	1	AP
	3R4-25445-00	SPROCKET, driven (45T)	1	AP
	3R4-25446-00	SPROCKET, driven (46T)	1	AP
	3R4-25448-00	SPROCKET, driven (48T)	1	AP
	3R4-25452-00	SPROCKET, driven (52T)	1	AP
21	90109-08706	BOLT	6	
22	95611-08100	NUT, u	6	
23	90201-081A6	WASHER, plate	6	

D9

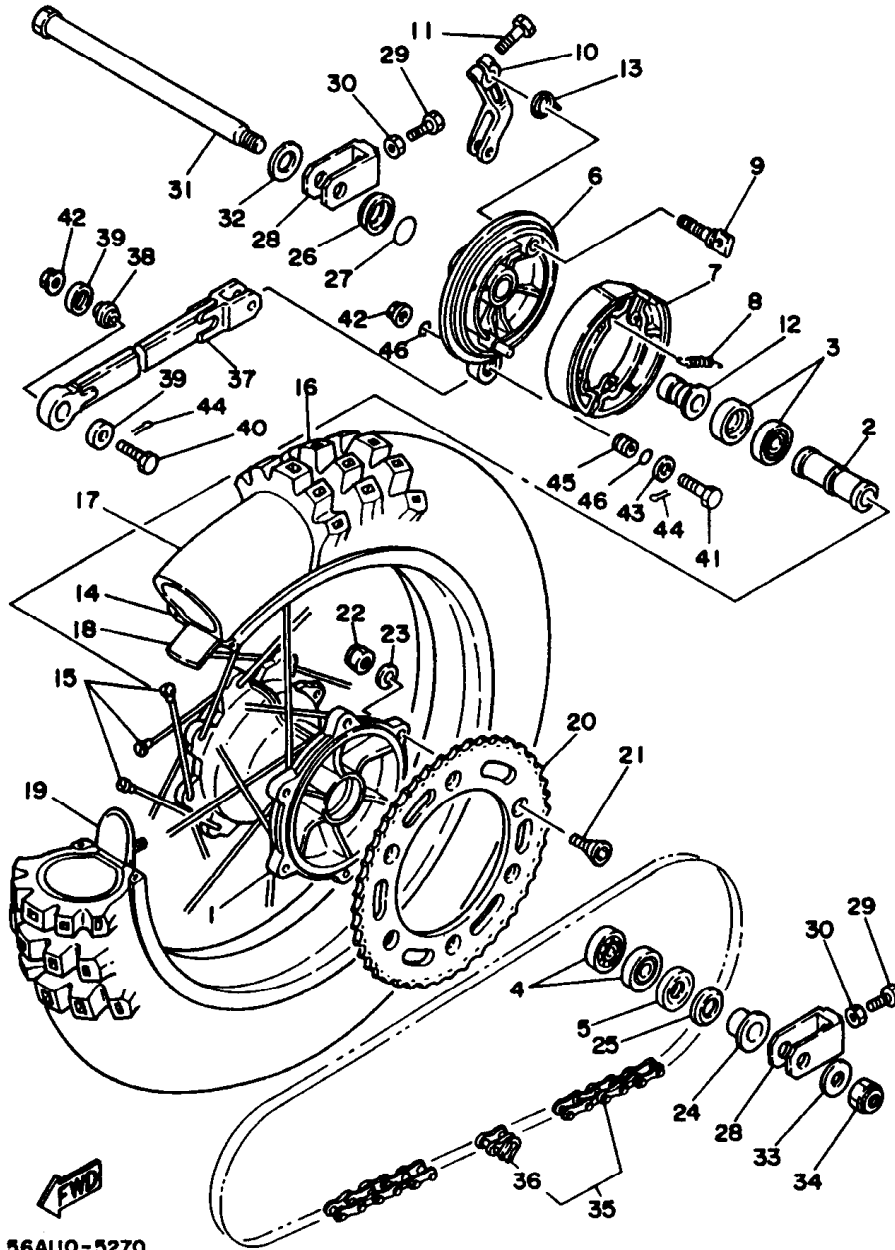

56A110-5270

FIG. 27 REAR WHEEL

REF. NO.	PART NO.	DESCRIPTION	Q'TY	REMARKS
24	90387-200H2	COLLAR	1	
25	4V4-25367-00	COVER, hub dust	1	
26	23X-25327-00	COVER, plate	1	
27	93210-31114	O-RING	1	
28	56A-25388-00	PULLER, chain 1	2	
29	90101-08475	BOLT	2	
30	95301-08700	NUT	2	
31	23X-25381-00	AXLE, wheel	1	
32	90209-21243	WASHER	1	
33	90209-18244	WASHER	1	
34	90185-18104	NUT, self-locking	1	
35	94585-20114	CHAIN, drive (DID520DS 114L)	1	
36	94685-20001	.JOINT, chain	1	
37	23X-25371-00	BAR, tension	1	
38	93399-99910	BEARING	1	
39	93112-19006	OIL SEAL	2	
40	90102-08034	BOLT, with hole	1	
41	90109-08370	BOLT	1	
42	90185-08113	NUT, self-locking	2	
43	92901-08600	WASHER, plate	1	
44	91401-20015	PIN, cotter	2	
45	90387-083F0	COLLAR	1	
46	93210-14167	O-RING	2	

FIG. 28 STEERING HANDLE. CABLE

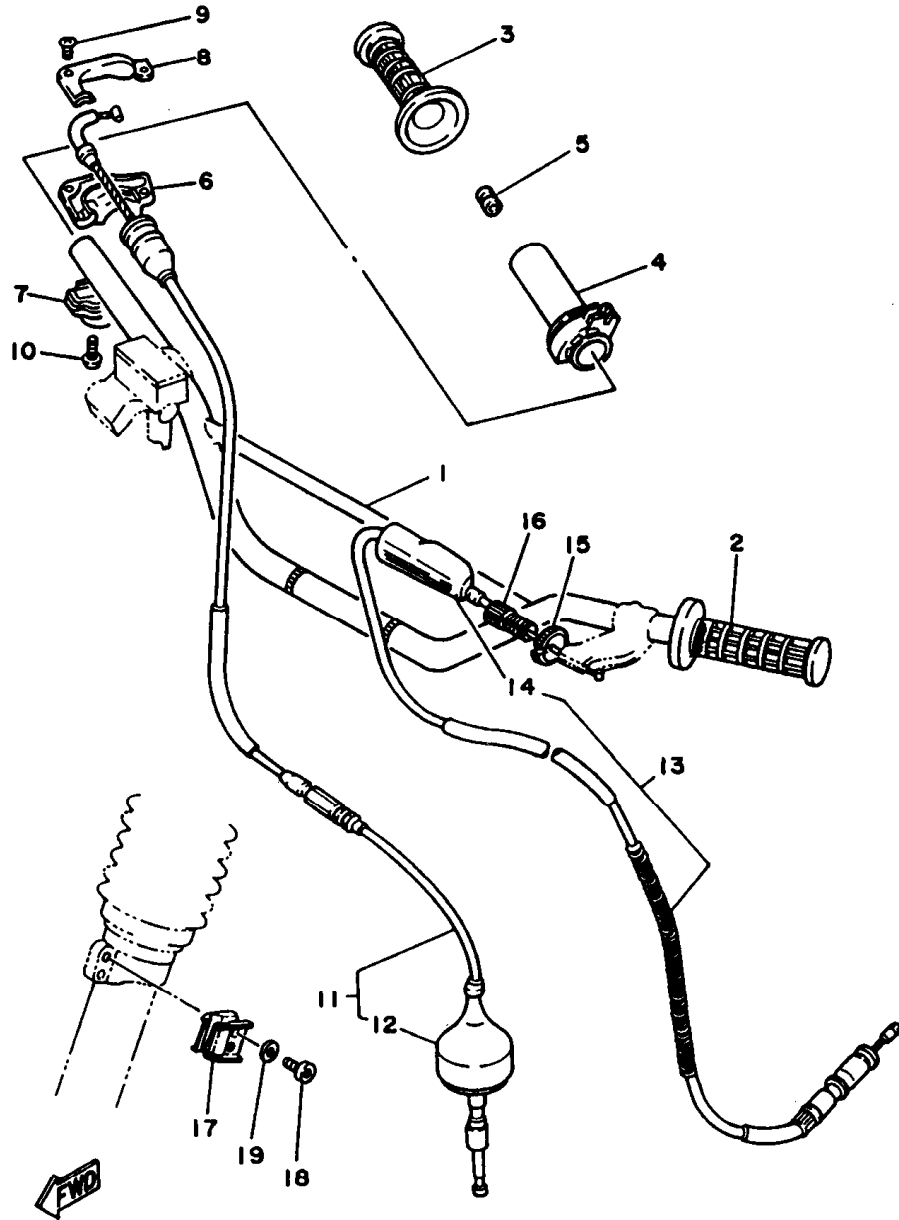

REF. NO.	PART NO.	DESCRIPTION	Q'TY	REMARKS
1	23X-26111-00	HANDLEBAR	1	
2	4V4-26241-01	GRIP (L.H)	1	
3	4V4-26242-01	GRIP (R.H)	1	
4	23X-26243-00	TUBE, throttle guide	1	
5	688-82535-00	GROMMET	1	
6	23X-26281-00	CAP, grip upper	1	
7	431-26282-01-98	CAP, grip lower	1	low gloss black
8	5X2-2628H-01	CAP, wire	1	
9	98606-04012	SCREW, oval head	2	
10	98506-05016	SCREW, pan head	2	
11	23X-26311-00	CABLE, throttle 1	1	
12	510-26329-00	.CAP, rubber	1	
13	39X-26335-00	CABLE, clutch	1	
14	382-26372-01	.COVER, handle lever 1	1	
15	90179-08401	NUT	1	
16	90123-08090	BOLT	1	
17	90465-16258	CLAMP	2	
18	91311-06016	BOLT	2	
19	90201-061A5	WASHER, plate	2	

56A110-5280

D11

FIG. 29 Front Master Cylinder

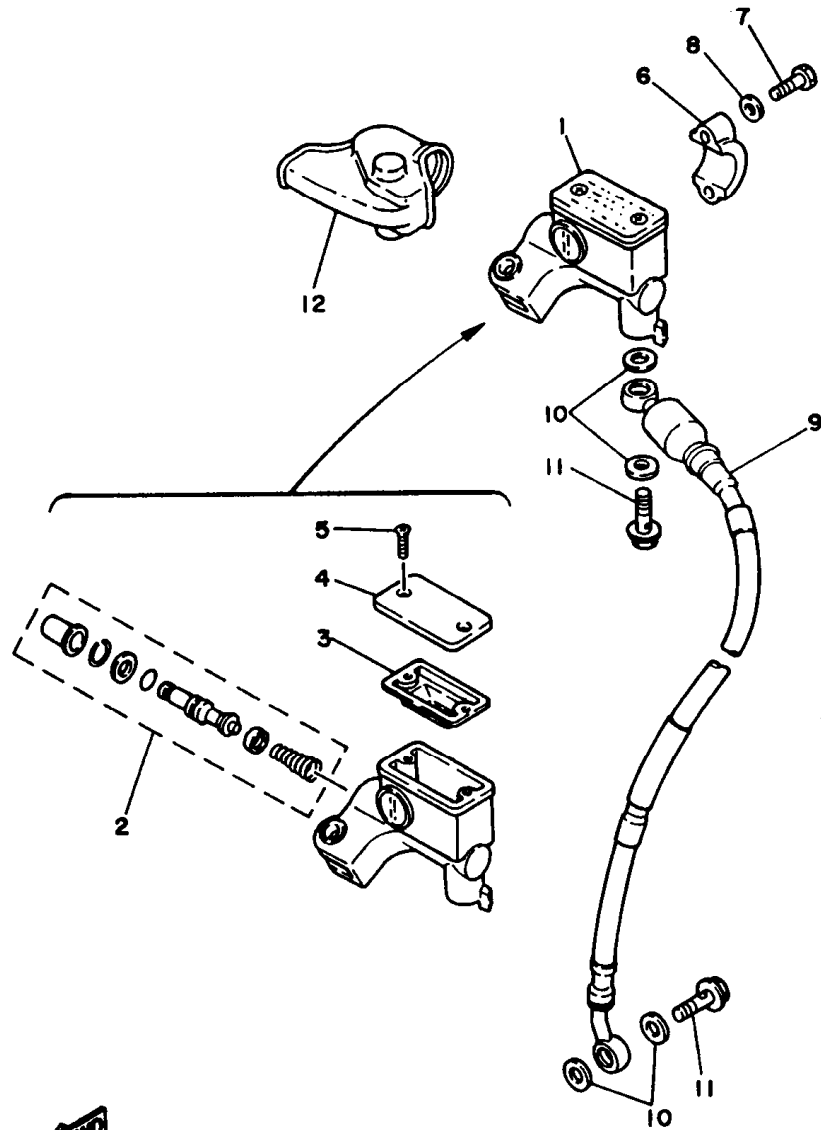

REF. NO.	PART NO.	DESCRIPTION	Q'TY	REMARKS
1	56A-25870-00	MASTER CYLINDER SUB ASSY	1	
2	56A-W0041-00	.CYLINDER KIT, master	1	
3	56A-25854-00	.DIAPHRAGM, reservoir	1	
4	56A-25852-00	.CAP, reservoir	1	
5	98706-04012	.SCREW, flat head	2	
6	56A-25867-00	BRACKET, master cylinder	1	
7	97326-06025	BOLT	2	
8	92906-06600	WASHER, plate	2	
9	56A-25872-00	HOSE, brake 1	1	
10	90201-10118	WASHER, plate	4	
11	90401-10034	BOLT, union	2	
12	56A-26372-00	COVER, handle lever 1	1	

56A110-5290

D12

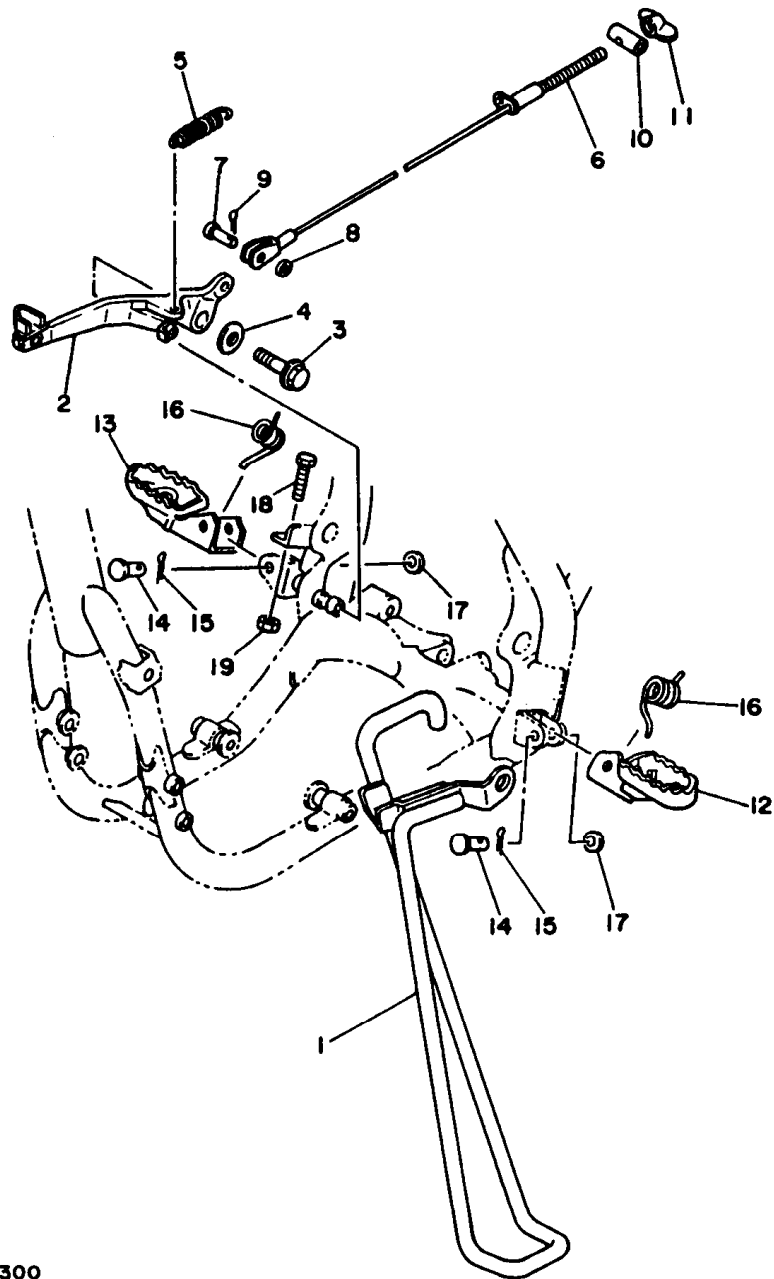

56A110-5300

FIG. 30 STAND. FOOTREST

REF. NO.	PART NO.	DESCRIPTION	Q'TY	REMARKS
1	39X-27311-00	STAND, side	1	
2	56A-27200-00	PEDAL, brake	1	
3	95801-08016	BOLT, flange	1	
4	90201-08730	WASHER, plate	1	
5	90506-16372	SPRING, tension	1	
6	39X-26351-00	CABLE, brake	1	
7	91790-08021	PIN, clevis	1	
8	90201-08544	WASHER, plate	1	
9	91401-25015	PIN, cotter	1	
10	90249-12008	PIN	1	
11	90175-06016	NUT, wing	1	
12	23X-27411-01	FOOTREST 1	1	
13	23X-27421-01	FOOTREST 2	1	
14	90240-10101	PIN, clevis	2	
15	91401-25020	PIN, cotter	2	
16	90508-20583	SPRING, torsion	2	
17	90201-10119	WASHER, plate	2	
18	90101-06586	BOLT	1	
19	95301-06700	NUT	1	

D13

FIG. 31 GENERATOR

REF. NO.	PART NO.	DESCRIPTION	Q'TY	REMARKS
1	56A-85510-K0	STATOR ASSY	1	
2	56A-85520-K0	.COIL, charge	1	
3	56A-85580-K0	.COIL, pulser	1	
4	92501-05028	.SCREW, pan head	2	
5	92901-05100	.WASHER, spring	2	
6	92501-05015	.SCREW, pan head	2	
7	92901-05100	.WASHER, spring	2	
8	56A-85550-K0	ROTOR ASSY	1	
9	92501-06020	SCREW, pan head	2	
10	90201-061A5	WASHER, plate	2	
11	95311-10600	NUT	1	
12	90201-10591	WASHER, plate	1	
13	7F6-82591-00	BAND	1	

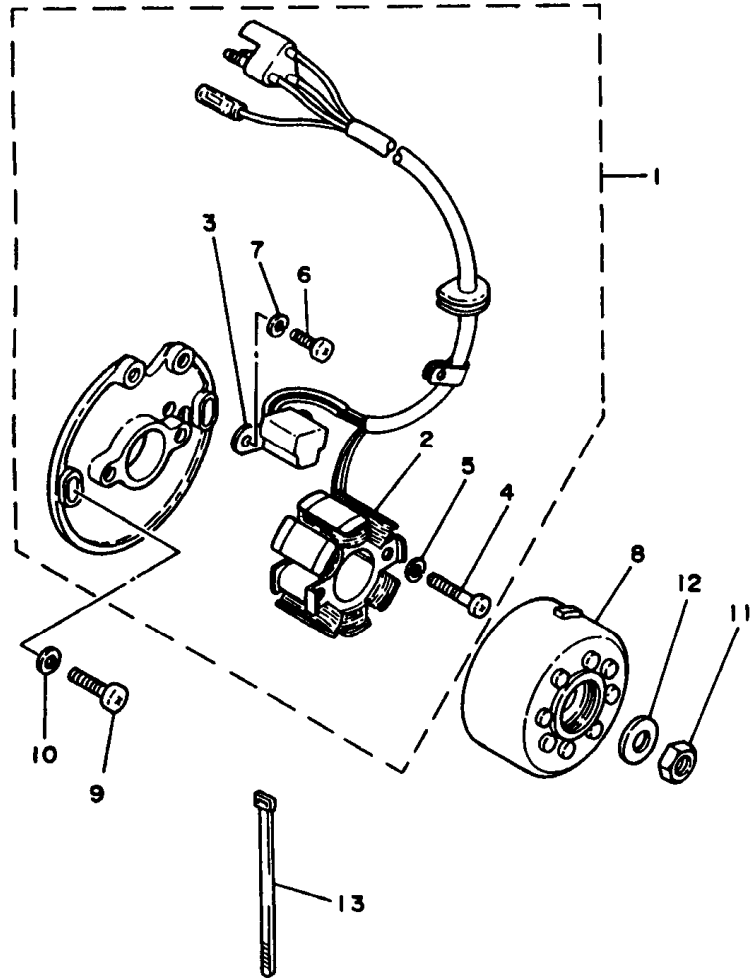

56A110-5310

D14

FIG. 32 HANDLE SWITCH. LEVER

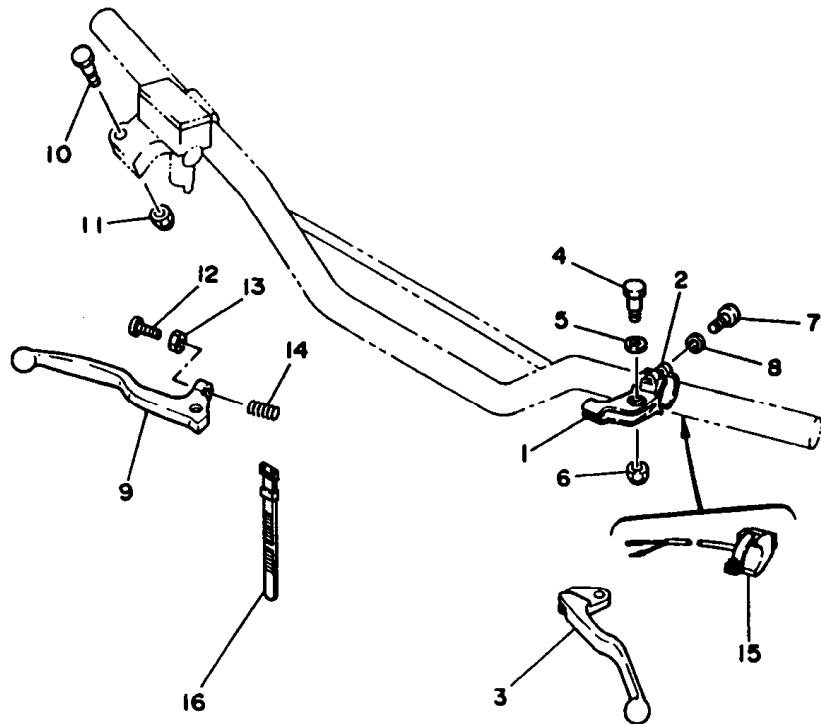

REF. NO.	PART NO.	DESCRIPTION	Q'TY	REMARKS
1	38V-82911-00	HOLDER, lever 1	1	
2	38V-82913-00	HOLDER, lever lower 1	1	
3	23X-83912-00	LEVER 1	1	
4	90109-06576	BOLT	1	
5	90201-082A9	WASHER, plate	1	
6	95606-06100	NUT, u	1	
7	98506-05018	SCREW, pan head	2	
8	92906-05100	WASHER, spring	2	
9	55Y-83922-00	LEVER 2	1	
10	90109-06577	BOLT	1	
11	95606-06100	NUT, u	1	
12	90149-06153	SCREW	1	
13	90170-06010	NUT	1	
14	90501-10312	SPRING, compression	1	
15	23X-83976-00	SWITCH, handle 1	1	
16	437-83936-00	BAND, switch cord	2	



56A110-5320

D15

FIG. 33 ELECTRICAL 1

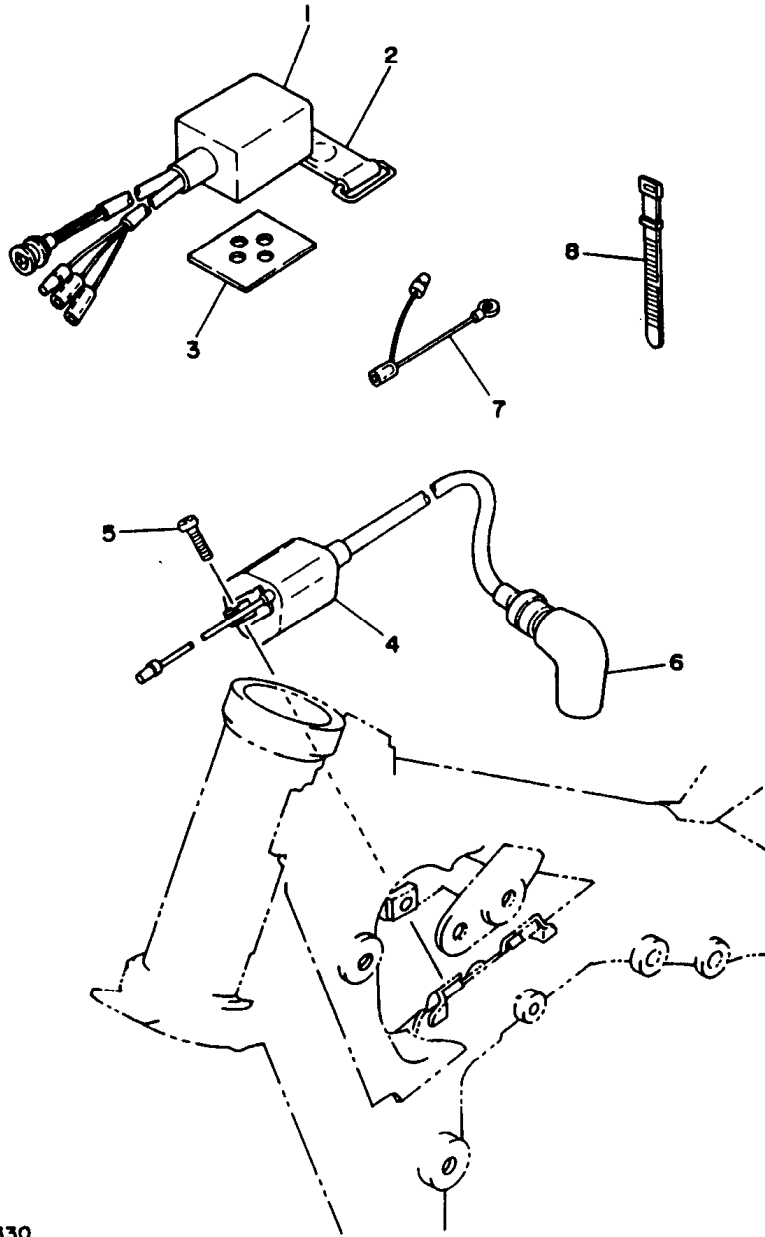

REF. NO.	PART NO.	DESCRIPTION	Q'TY	REMARKS
1	56A-85540-K0	C.D.I. UNIT ASSY	1	
2	288-21376-00	BAND, tool	1	
3	2K7-85547-00	DAMPER	1	
4	24X-82310-10	IGNITION COIL ASSY	1	
5	92502-06016	SCREW, pan head	2	
6	3R0-82370-20	PLUG CAP ASSY	1	
7	5X1-82519-00	WIRE, earth lead	1	
8	256-83936-00	BAND, switch cord	1	



56A110-5330

E2

FIG. 34 ALTERNATE 1 (CHASSIS)

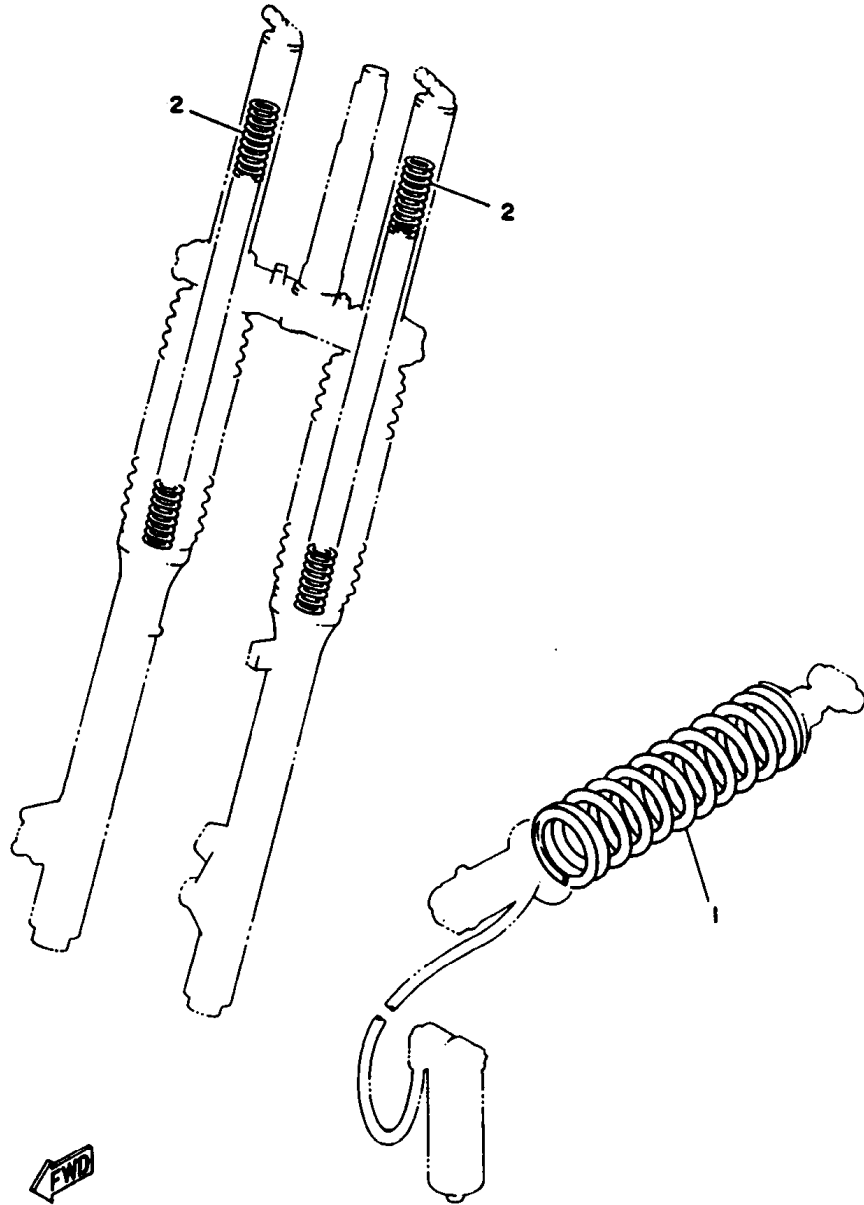

REF. NO.	PART NO.	DESCRIPTION	Q'TY	REMARKS
1	56A-22212-10-6W	SPRING (K=4.0)	1	UR AP native red (soft)
	39X-22212-00-6W	SPRING (K=4.5)	1	UR AP native red (hard)
2	39X-23141-10	SPRING, front fork (K=0.275)	2	UR AP (soft)
	39X-23141-20	SPRING, front fork (K=0.325)	2	UR AP (hard)

39W100-4320

E3

FIG. 35 REPAIR KIT

REF. NO.	PART NO.	DESCRIPTION	Q'TY	REMARKS
1	56A-11630-00	PISTON ASSY (STD)	1	AP
	56A-11631-00-93	.PISTON (STD)	1	
2	56A-11601-00	.PISTON RING SET (STD)	1	
3	214-11633-00	.PIN, piston	1	
4	93450-19052	.CIRCLIP	2	
5	56A-11630-10	PISTON ASSY (1ST O/S)	1	AP
6	56A-11635-00	.PISTON (0.25MM O/S)	1	
7	56A-11601-10	.PISTON RING SET (1ST O/S)	1	
8	214-11633-00	.PIN, piston	1	
9	93450-19052	.CIRCLIP	2	
10	56A-11630-20	PISTON ASSY (2ND O/S)	1	AP
11	56A-11636-00	.PISTON (0.50MM O/S)	1	
12	56A-11601-20	.PISTON RING SET (2ND O/S)	1	
13	214-11633-00	.PIN, piston	1	
14	93450-19052	.CIRCLIP	2	
15	56A-11630-30	PISTON ASSY (3RD O/S)	1	AP
16	56A-11637-00	.PISTON (0.75MM O/S)	1	
17	56A-11601-30	.PISTON RING SET (3RD O/S)	1	
18	214-11633-00	.PIN, piston	1	
19	93450-19052	.CIRCLIP	2	
20	24Y-11650-01	CONNECTING ROD ASSY	1	AP
21	2X4-11681-00	.PIN, crank 1	1	
22	24Y-11651-00	.ROD, connecting	1	
23	90209-25085	.WASHER	2	
24	93310-425N4	.BEARING, cylindrical	1	
25	93310-418E9	.BEARING, cylindrical	1	

NUMERICAL INDEX

PART NO.	GRID NO.	PART NO.	GRID NO.	PART NO.	GRID NO.	PART NO.	GRID NO.	PART NO.	GRID NO.	PART NO.	GRID NO.
56A-W0041-00	D-12	2X4-11681-00	E- 4	2X8-14112-35	B-11	23X-15381-00	B-14	5X5-18531-01	C- 6	56A-22401-00	C-13
56A-W0046-00	D- 8	5X5-11911-01	B- 4	510-14115-00	B-11	56A-15383-00	B-14	5X5-18535-01	C- 6	39X-22409-00	C-13
56A-W0047-00	D- 8	5X5-11912-01	B- 4	431-14131-00	B-11	39X-15411-00	B-15	24Y-18540-00	C- 6	56A-22463-00	C-13
51L-W0048-00	D- 8	56A-11915-00	B- 2	510-14141-48	B-11	23X-15421-00	B-15	56A-21110-00-FH	C- 8	26A-22472-00	C-13
56A-W0057-00	D- 8	5X5-11921-00	B- 4	510-14141-50	B-11	24Y-15431-00	B-15	288-21376-00	E- 2	23X-22475-00	C-13
39X-W1132-00	B- 2	5X5-11922-00	B- 4	510-14141-52	B- 4	5X5-15451-00	B-15	24Y-21415-00	C- 8	56A-22489-00	C-13
5X5-W1133-00	B- 2	5X5-11931-00	B- 4	193-14142-55	B-11	5X5-15462-00	B-15	39X-21425-00	C- 8	39X-22493-00	C-13
39X-W1441-00	B- 9	5X5-11937-00	B- 2	193-14142-60	B-11	24Y-15618-00	C- 2	39X-21426-00	C- 8	5X3-22497-00	C-13
39X-W2473-20	D- 6	5X5-11951-00	B- 4	193-14142-65	B-11	56A-15620-00	C- 2	5X6-21511-10	C- 9	56A-22499-10	C-13
56A-11111-00	B- 2	5X5-11952-00	B- 4	137-14143-60	B-11	24Y-15621-00	C- 2	4V2-21543-01	C- 9	56A-23102-MO	D- 2
56A-11181-00	B- 2	5X5-11953-00	B- 4	137-14143-62	B-11	3R4-15641-00	C- 2	3R4-21611-10	C- 9	56A-23103-MO	D- 2
56A-1131A-00	B- 2	24Y-11990-00	B- 4	137-14143-64	B-11	3R4-15651-00	C- 2	39X-21620-00	C- 9	56A-23110-MO	D- 2
5X5-1131N-00	B- 2	39X-11992-00	B- 3	509-14145-00	B-12	56A-15661-00	C- 2	39X-21642-00	C- 9		D- 3
56A-11311-00	B- 2	39X-11993-00	B- 3	3R4-14146-00	B-12	3R4-15664-00	C- 2	39X-21711-10-98	C-10	43M-23111-L0	D- 2
39X-11351-00	B- 2	39X-11995-00	B- 3	558-14147-00	B-12	24Y-16110-00	C- 3	24Y-2172A-00	C-10		D- 3
56A-11400-00	B- 5	39X-1240A-01	B- 7	5X5-14153-00	B-12	39X-16150-00	C- 3	39X-21721-10-98	C-10	5X6-23118-10	D- 2
24Y-11412-01	B- 5	39X-12422-00	B- 6	5Y9-14158-00	B-11	2K7-16154-00	C- 3	39X-21731-10	C-10		D- 3
24Y-11422-01	B- 5	5X5-12428-00	B- 6	1W3-14173-00	B-12		C- 3	39X-21737-10	B- 9	4H7-23119-00	D- 2
56A-11601-00	B- 5	39X-12450-00	B- 6	363-14184-00	B-11	2K7-16181-00	C- 3		C-10		D- 3
	E- 4	39X-12459-00	B- 6	2N7-14185-00	B-11	5X5-16321-00	C- 3	39X-2174F-00	C-10	55Y-2312G-MO	D- 2
56A-11601-10	B- 5	39X-12460-01	B- 7	573-14186-00	B-11	4H7-16325-00	C- 3	39X-21741-10	C-10		D- 3
	E- 4	22W-12462-00	B- 7	2K7-14197-00	B-11	23X-16351-00	C- 3	22W-21791-00	B- 7	4V4-23125-L0	D- 2
56A-11601-20	B- 5	24X-12465-00	C-10	310-14197-00	B-11	23X-16356-00	C- 3		B- 7		D- 3
	E- 4	24X-12469-00	B- 7	43N-14412-00	B- 9	2K7-16357-01	C- 3		C-10	56A-23126-L0	D- 2
56A-11601-30	B- 5	24Y-12469-00	B- 7	39X-14451-00	B- 9	23X-16371-00	C- 3	56A-22110-00	C-11	122-23129-00	D- 2
	E- 4	39X-12476-00	B- 7	39X-14452-00	B- 9	38W-16380-00	C- 3	156-22127-00	C-11		D- 3
56A-11630-00	E- 4	39X-12477-00	B- 7	39X-14453-00	B- 9	24Y-17121-00	C- 4	23X-22129-00	C-12	56A-23136-L0	D- 2
56A-11630-10	E- 4	39X-1248A-00	B- 7	39X-14457-00	B- 9	39X-17131-00	C- 4	3R4-22129-00	C-11	39X-23141-00	D- 2
56A-11630-20	E- 4	39X-12481-00	B- 7	39X-14457-00	B- 9	39X-17141-00	C- 4	5X6-22141-01	C-11		D- 3
56A-11630-30	E- 4	39X-12482-00	B- 7	39X-14458-00	B- 9	39X-17151-00	C- 4	39W-22151-00	C-11	39X-23141-10	E- 3
56A-11631-00-93	B- 5	39X-12483-00	B- 7	56A-14459-00	B- 9	256-17154-00-10	C- 4	39X-2217A-00	C-11	39X-23141-20	E- 3
	E- 4	39X-12484-00	B- 7	39X-14462-00	B- 9	24Y-17211-00	C- 4	39X-2217F-00	C-12	4V4-23142-L0	D- 2
56A-11631-00-94	B- 5	39X-12485-00	B- 7	56A-14468-00	B- 9	24Y-17221-00	C- 4	22W-22178-01	C- 8		D- 3
214-11633-00	B- 5	56A-12498-00	B- 8	56A-14610-00	B-13	39X-17231-00	C- 4	5X3-2218A-00	C-12	23X-23144-L0	D- 2
	E- 4	137-13115-00	B-14	24Y-14613-00	B-13	39X-17241-00	C- 4	4V4-22184-00	C- 8		D- 3
	E- 4	39X-13565-00	B- 9	39X-14619-00	B- 2	39X-17251-00	C- 4	23X-22199-10	C-11	23X-23145-L0	D- 2
	E- 4	56A-13610-00	B- 9	56A-1469A-00	B-13	24Y-17411-00	C- 4	56A-22210-10-6W	C-13		D- 3
	E- 4	56A-13613-00	B- 9	39X-14747-00	B-13	5X5-17421-00	C- 4	23X-22211-00	C-14	4V4-23146-L0	D- 2
56A-11635-00	B- 5	56A-13616-00	B- 9	56A-14753-00	B-13	23X-17461-30	C- 4	39X-22212-00-6W	E- 3		D- 3
	E- 4	39X-13621-00	B- 9	24Y-14771-00	B-13	23X-17461-40	C- 4	39X-22212-10-6W	C-13	3J2-23147-00	D- 2
56A-11636-00	B- 5	26A-1410A-00	B-12	565-14771-00	B-13	23X-17461-50	C- 5	56A-22212-10-6W	E- 3		D- 3
	E- 4	56A-14101-10	B-11	23X-1490J-00	B-11	23X-18101-00	C- 7	23X-22213-00	C-13	55Y-23152-MO	D- 2
56A-11637-00	B- 5	23X-14103-00	B-11	5X5-15111-03	B-14	24Y-18110-00	C- 7	23X-22214-00	C-13		D- 3
	E- 4	23X-14104-00	B-11	5X5-15113-00	B-14	3R4-18140-00	C- 6	3R4-22221-01	C-13	4V4-23153-L0	D- 2
24Y-11650-01	E- 4	23X-14106-00	B-11	3R4-15118-00	B-14	1W1-18177-00	C- 6	23X-22223-00	C-13		D- 2
24Y-11651-00	B- 5	23X-14107-35	B-11	5X5-15121-01	B-14	5X5-18511-00	C- 6	3R4-22228-00	C-13	4V4-23157-L0	D- 2
	E- 4	2X8-14112-25	B-11	1G8-15362-00	B-15	4V3-18512-00	C- 6	56A-22261-00	C-14		D- 3
2X4-11681-00	B- 5	2X8-14112-30	B-11	56A-15378-00	B-15	5X5-18513-00	C- 6	24X-22262-00	C-14	23X-23158-L0	D- 2

NUMERICAL INDEX

PART NO.	GRID NO.	PART NO.	GRID NO.	PART NO.	GRID NO.	PART NO.	GRID NO.	PART NO.	GRID NO.	PART NO.	GRID NO.
23X-23158-L0	D- 3	5R2-25197-00	D- 8	23X-27421-01	D-13	90119-06073	D- 5	90201-06571	C- 9	90209-25085	B- 5
56A-2316A-M0	D- 2	56A-25304-00	D- 9	23X-28100-01	C- 8	90123-08090	D-11		C-10		E- 4
	D- 3	56A-25311-00-98	D- 9	2X4-2811A-00	C- 8	90149-06011	D- 5		C-10	90215-20212	C- 3
56A-23170-M0	D- 2	23X-25321-00-98	D- 9	23X-28135-00	C- 8	90149-06153	D-15		C-15	90215-21239	C- 5
	D- 3	23X-25327-00	D-10	24X-82310-10	E- 2	90149-06178	C- 3	90201-08087	B- 2	90240-10101	D-13
4V4-23171-L0	D- 2	23X-25330-00	D- 9	3R0-82370-20	E- 2	90152-06010	C- 2	90201-081A6	D- 9	90249-12008	D-13
	D- 3	39X-25351-00	D- 9	5X1-82519-00	E- 2	90159-05100	C-10	90201-082A9	D-15	90267-48121	B-13
23X-23173-L0	D- 2	5X4-25355-00	D- 9	688-82535-00	D-11		C-10	90201-08512	B- 6	90280-03017	B- 5
	D- 3	4V4-25367-00	D-10	7F6-82591-00	D-14	90159-06016	C- 3	90201-08544	D- 4	90339-13005	C- 8
5X6-23181-L0	D- 3	23X-25371-00	D-10	38V-82911-00	D-15	90170-06010	D-15		D-13	90340-12095	B-14
4V4-23188-L0	D- 2	23X-25381-00	D-10	38V-82913-00	D-15	90170-20213	C-13	90201-08612	B-13	90380-15104	B- 4
	D- 3	56A-25388-00	D-10	23X-83912-00	D-15	90170-20255	C- 3	90201-087F0	D- 6	90380-16077	C-11
34K-2319U-00	C-15	39X-25394-00	D- 9	55Y-83922-00	D-15	90175-06016	D-13	90201-08730	B-13	90380-22111	C-11
23X-23190-L0	D- 2	3R4-25444-01	D- 9	256-83936-00	E- 2	90176-08026	B- 2		D-13	90381-08002	B- 6
	D- 3	3R4-25445-00	D- 9	437-83936-00	C- 9	90179-08401	D-11	90201-08753	C- 8	90387-060A7	B- 7
43M-23191-L0	D- 3	3R4-25446-00	D- 9		D-15	90179-10280	C- 8	90201-100E9	C-12	90387-06387	D- 5
43M-23192-L0	D- 3	3R4-25448-00	D- 9	437-83936-10	B- 7	90179-12244	C- 2		C-14	90387-06681	C- 9
39X-23340-00	D- 3	3R4-25450-00	D- 9	23X-83976-00	D-15	90179-20255	C- 5	90201-10118	D-12	90387-07392	B- 7
3R4-23389-00	C-15	3R4-25452-00	D- 9	56A-85510-K0	D-14	90179-22330	C-15	90201-10119	D-13	90387-081A3	B-13
1W1-23416-00	C-15	56A-25810-00	D- 8	56A-85520-K0	D-14	90179-25033	C-15	90201-10138	B- 6	90387-083F0	D-10
39W-23435-00-98	C-15	56A-25831-00	D- 8	56A-85540-K0	E- 2	90185-08106	C- 8	90201-10139	C- 8	90387-083F4	B- 4
1E6-23441-00	C-15	34X-25845-00	D- 8	2K7-85547-00	E- 2		C-11	90201-10430	C-12	90387-102F3	B- 2
24X-23485-10	C-15	56A-25852-00	D-12	56A-85550-K0	D-14	90185-08113	C- 8		C-14	90387-121H1	C-12
43M-23489-L0	D- 3	56A-25854-00	D-12	56A-85580-K0	D-14		C- 8	90201-10591	D-14	90387-126H8	C-14
39X-24110-10	D- 5	56A-25867-00	D-12	90101-06291	D- 9		D-10	90201-120A5	C-11	90387-127G8	C-14
5X6-2412F-00	D- 5	56A-25870-00	D-12	90101-06586	D-13	90185-10120	C-12	90201-120E6	C-12	90387-147G6	C-11
24X-24144-00	D- 5	56A-25872-00	D-12	90101-08475	D-10		C-14		C-14	90387-147G7	C-11
3R3-24173-00	D- 5	56A-25919-00	D- 8	90102-08034	D-10		C-14	90201-13202	C- 8	90387-152F2	B- 4
22W-24181-00	C-10	56A-25919-10	D- 8	90109-06551	B-13	90185-12119	C-11	90201-14222	C-11	90387-15535	D- 7
39X-24181-00	D- 5	56A-25926-00	D- 8	90109-06576	D-15	90185-16127	C-11	90201-151A7	B- 4	90387-157L9	D- 7
23X-24184-00	D- 5	56A-25937-00	D- 8	90109-06577	D-15	90185-18104	D-10		B- 4	90387-160H4	B-14
56A-24250-10	D- 5	23X-26111-00	D-11	90109-06757	D- 8	90185-18126	C- 3	90201-154F5	B- 4	90387-200H1	D- 9
2K5-24500-00	D- 5	4V4-26241-01	D-11	90109-08370	D-10	90201-05029	C-10	90201-154F6	B- 4	90387-200H2	D-10
1A0-24512-00	D- 5	4V4-26242-01	D-11	90109-08397	D- 4	90201-057H5	B- 4	90201-160F6	C-11	90387-252F6	C- 3
214-24512-00	D- 5	23X-26243-00	D-11	90109-08512	B-13	90201-06052	C- 9	90201-17327	C- 3	90387-25663	C- 4
619-24535-00	D- 5	5X2-2628H-01	D-11	90109-08705	C- 8	90201-06067	C-11	90201-17545	C- 2	90401-10034	D-12
5X7-24611-01	D- 5	23X-26281-00	D-11	90109-08706	D- 9	90201-06069	D- 5	90201-186H3	C- 3	90430-06016	B-15
5X7-24612-00	D- 5	431-26282-01-98	D-11	90109-10700	C-14	90201-061A5	B- 7	90201-20278	C- 4	90430-06166	B- 6
509-24724-00	D- 6	23X-26311-00	D-11	90109-10702	C-12		B- 7	90201-20358	C- 2	90430-06192	B- 2
23X-24731-20	D- 6	510-26329-00	D-11	90109-10703	C-12		B-10	90201-22555	C- 4	90430-12038	B-14
39W-24738-00	D- 6	39X-26335-00	D-11	90109-10704	C-13		B-13	90202-06010	D- 5	90445-08605	B-14
22W-24741-00	D- 6	39X-26351-00	D-13	90109-12701	C-11		D- 5	90202-08022	C- 8	90445-09300	D- 5
5X6-24748-10	D- 6	382-26372-01	D-11	90116-08392	B- 2		D- 5	90206-14067	C-13	90445-11356	D- 5
56A-25104-00	D- 7	56A-26372-00	D-12	90116-08394	B- 2		D- 6	90209-17235	C- 4	90446-09079	B- 7
56A-25111-00-98	D- 7	23X-26393-00	B-14	90116-10313	B- 2		D-11	90209-18135	C- 4	90460-15227	B- 8
322-25118-00	D- 7	56A-27200-00	D-13	90116-10314	B- 2		D-14	90209-18244	D-10	90460-22252	B- 8
3R4-25181-01	D- 7	39X-27311-00	D-13	90119-06042	C- 9	90201-06570	B- 7	90209-21243	D-10	90460-31253	B- 7
4V5-25194-00	D- 7	23X-27411-01	D-13	90119-06056	B-10	90201-06571	C- 9	90209-22082	C- 4	90460-51109	B- 9

NUMERICAL INDEX

PART NO.	GRID NO.	PART NO.	GRID NO.	PART NO.	GRID NO.	PART NO.	GRID NO.	PART NO.	GRID NO.	PART NO.	GRID NO.
90460-68199	B- 9	92501-06014	C-10	92990-05100	B-11	93399-99916	C-13	95606-06100	D-15		
90465-06247	B-15		C-10	93102-12106	C- 7		C-13	95611-08100	D- 9		
90465-16258	D-11	92501-06020	D-14	93102-17263	C- 3	93410-17008	C- 2	95611-10100	C-12		
90467-09006	B- 7	92501-08010	B-14	93102-20309	C- 2	93410-20038	C- 4	95701-10500	B- 2		
90467-10008	D- 5	92502-06016	E- 2	93102-32407	C- 4	93410-22039	C- 4	95801-06012	D- 6		
90468-26048	C- 2	92506-06008	B-15	93103-10113	B- 6	93430-07012	B- 6	95801-06020	C-11		
90480-15064	B- 7	92506-06012	B-15	93103-30092	B- 5	93440-25084	C- 4	95801-08016	D-13		
90480-18276	B- 7	92506-06025	B- 6	93103-40091	B- 5	93440-30113	C-13	95802-08012	C- 8		
90480-18354	D- 5		B-15	93104-08040	B- 4		C-13	95802-08055	C-11		
90480-25381	C-14		B-15	93104-16074	B- 2	93440-51103	C-13	95806-06012	B- 2		
90501-10312	D-15		B-15	93104-18077	C-13	93450-19052	B- 5	95811-08040	D- 8		
90501-13720	C- 2	92506-06030	B-15	93106-20021	D- 7		E- 4	95811-08055	C- 8		
90501-23346	C- 3	92506-06040	B-15	93106-22019	C-11		E- 4	95811-08100	C- 8		
90501-24745	B- 4	92506-06065	B-15	93106-28023	D- 9		E- 4	95811-08180	C- 8		
90504-03033	B- 9	92701-06012	B-14	93108-35004	C-11		E- 4	95811-10055	C- 8		
90506-16372	D-13	92901-05100	B- 3	93109-20029	C-11	93501-04011	C- 2	95821-08020	C- 8		
90506-17328	D- 9		D-14	93112-19006	D-10	93515-32029	C- 3	95821-08035	C-15		
90507-20030	B-13		D-14	93210-09192	B- 2	93521-64032	B- 4	95821-08040	C-15		
90508-14423	C- 3	92901-05200	B- 9	93210-14104	B-15	93603-14179	B- 4	95826-06025	B- 6		
90508-20583	D-13	92901-05600	B- 4	93210-14167	D-10	93603-22028	B- 6	97301-06012	B-10		
90508-26608	C- 6	92901-06100	B- 9	93210-19216	C- 2	93604-10011	B- 6		D- 6		
90508-29361	C- 7		B-10	93210-31114	D-10	93604-21193	C-13	97301-06016	B-13		
90508-29596	D- 9		B-13	93210-35512	B- 2	93604-26132	C-13		C- 9		
90508-30422	C- 2		C- 3	93300-20501	C- 4	93606-14154	C- 6		D- 5		
90560-12171	C- 7		C- 9		C- 4	93608-25150	C- 7	97301-06020	B- 7		
90560-15227	D- 7		C-10	93300-60801	B- 4	93700-06004	C-11		C- 9		
90560-20226	D- 9		C-10	93306-00006	B- 4		C-12	97301-06030	B- 7		
91311-06016	D-11		D- 5	93306-00106	C- 6	93700-06005	C-12	97301-08016	B-13		
91316-04006	B- 4	92901-06200	B- 9	93306-00406	D- 9	94109-21264	D- 7		C-10		
91316-06020	B- 9	92901-08100	B-13	93306-00430	D- 9	94113-18263	D- 9		D- 6		
91316-06040	B-14		B-13	93306-20205	D- 7	94209-21229	D- 7	97301-08060	B-13		
91316-06045	B-14		C-10	93306-20627	B- 5	94213-18232	D- 9	97302-06020	C- 9		
91316-06055	B-14		D- 4		B- 5	94330-21084	D- 7	97321-06025	C- 7		
91316-06060	B-14		D- 6	93310-418E9	B- 5	94340-18086	D- 9	97326-06025	D-12		
91401-20015	D-10	92901-08600	B-13		E- 4	94416-21412	D- 7	98501-04006	C-13		
91401-25015	D-13		D-10	93310-425N4	B- 5	94421-18414	D- 9	98501-05012	B- 3		
91401-25020	D-13	92901-10200	C- 8		E- 4	94585-20114	D-10	98501-05016	B-11		
91790-08021	D-13	92902-06700	C- 9	93311-41734	C- 4	94685-20001	D-10	98503-03006	B- 9		
91810-03014	B- 2		C- 9	93311-62035	C- 4	95301-05800	C-10	98506-04018	D- 3		
91810-05016	B-14	92902-08200	C-10	93315-21721	C- 3	95301-06600	C- 3	98506-05012	B- 2		
91830-24016	B- 2	92903-03100	B- 9	93315-31732	C-12	95301-06700	D-13	98506-05014	B- 3		
92501-05015	D-14	92906-05100	D-15	93317-32034	C-11	95301-08700	D-10	98506-05016	D-11		
92501-05028	D-14	92906-06100	B-15	93317-32231	C-11	95311-08600	D- 4	98506-05018	B- 3		
92501-06010	B-14	92906-06600	B-15	93332-00008	C-15	95311-10600	D-14		D-15		
92501-06012	B- 9		B-15		C-15	95601-05100	B- 4	98606-04012	D-11		
	B-14		B-15	93332-00023	C-15		B- 9	98706-04012	D-12		
	C-15		B-15	93342-22208	C-11	95601-06100	C- 9	98902-06018	D- 5		
	D- 5		D-12	93399-99910	D-10	95606-06100	D-15				