

PARTS CATALOGUE

YZ250N (5MW1) CANADA,U.S.A,SOUTH AFRICA

YZ250 (5MW2) EUROPE

YZ250 (5MW3)

YZ250N (5MW4) OCEANIA

YZ250N/YZ250
PARTS CATALOGUE
©2001 by Yamaha Motor Co., Ltd.
1st Edition, Jun. 2001
All rights reserved.
Any reprinting or unauthorized use
without the written permission of
Yamaha Motor Co., Ltd.
is expressly prohibited.

A3



A4

FOREWORD

This Parts Catalogue is related to the parts for the model(s) in the below frame. When you are ordering replacement parts, please refer to this Parts Catalogue and quote both part numbers and part names correctly.

YZ250N(5MW1/5MW4), YZ250(5MW2/5MW3)

1. Modifications or additions which have been made after issue of the Parts Catalogue will be announced in the Yamaha Parts News. It is advisable that you make necessary corrections to the Parts Catalogue according to the Yamaha Parts News.

2. Abbreviations
The Following abbreviations are used in this Parts Catalogue.

- “UR” Use specified parts number.
- “UN” Use as many as needed.
- “AP” Alternate Parts
- “LM” Local Made (Parts need to be ordered locally)
- “F#” Frame No. (Applicable machine No.)

3. Parts, which are to be supplied in an assembly, are listed with a dot(.) in front of the part name as shown below.

EXAMPLE
 CARBURETOR ASSY
 .JET, PILOT
 .NOZZLE, MAIN

4. Number of component for assembly
 The numeral appearing to the right of each component part indicates the quantity of parts for each assembly unit.

EXAMPLE

PART NO.	DESCRIPTION	Q'TY	REMARKS
2F5-83310-60	FRONT FLASHER LIGHT ASSY	2	
115-83311-60	.BULB (6V-18W)	1	
1M1-83309-60	.REFLECTOR	1	

5. Applicable colors of graphics are represented in the “REMARKS” as shown below.

PART NO.	DESCRIPTION	Q'TY	REMARKS
2N4-24110-00-X5	FUEL TANK COMP.	1	MXR
3J1-24240-10	.GRAPHIC, FUEL TANK	1	FOR MXR

6. Applicable Serial No.

Engine Serial No.

Frame Serial No.

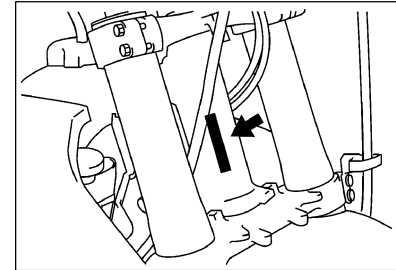
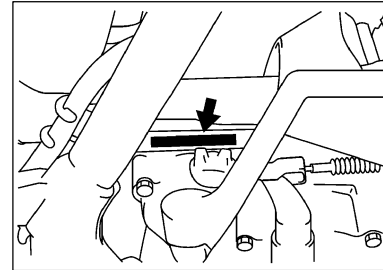

7. Note that the illustrations for reference in finding parts numbers, not to be used for assembling. When assembling, please use the applicable service manual.

8. The asterisk (*) before a reference number indicates modification items after the first edition.

MODEL LABEL

(1) A label called "Model Label" is affixed in the location as indicated in (3) below.
When using this parts catalogue, please be sure to cross-refer the "model code – production code No." in the catalogue to the "model code – production code No." indicated on the Model Label affixed onto the product concerned.

(2) "Model Label" Indication

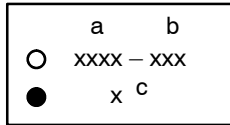

a: Model Type Code
b: Production Code No.
c: Colouring Type

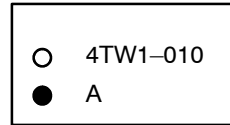

(3) Model Label Affixing Location

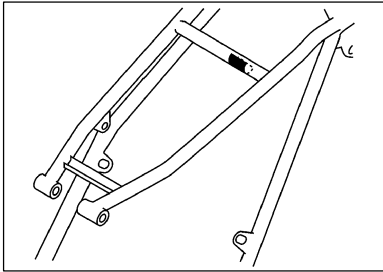

(4) Model Code – Production Code Number of Model Listed in This Parts Catalog

Model Code	Production Code No.	Country (destination)	Model Code	Production Code No.	Country (destination)
5MW1	010	U.S.A.			
	020	CANADA			
	030	SOUTH AFRICA			
5MW2	010	FRANCE			
	020	GERMANY			
	030	SPAIN			
	040	ENGLAND			
	050	ITALY			
5MW3	010	JAPAN			
5MW4	010	AUSTRALIA			
	020	NEW ZEALAND			

(5) Colouring Information

Model Code	Colouring type code	Colour code	Colour Name	Abbreviation
5MW1	A	0583	DEEP PURPLISH BULE SOLID E	DPBSE
5MW2				
5MW3				
5MW4				

FIG. 1 CYLINDER HEAD

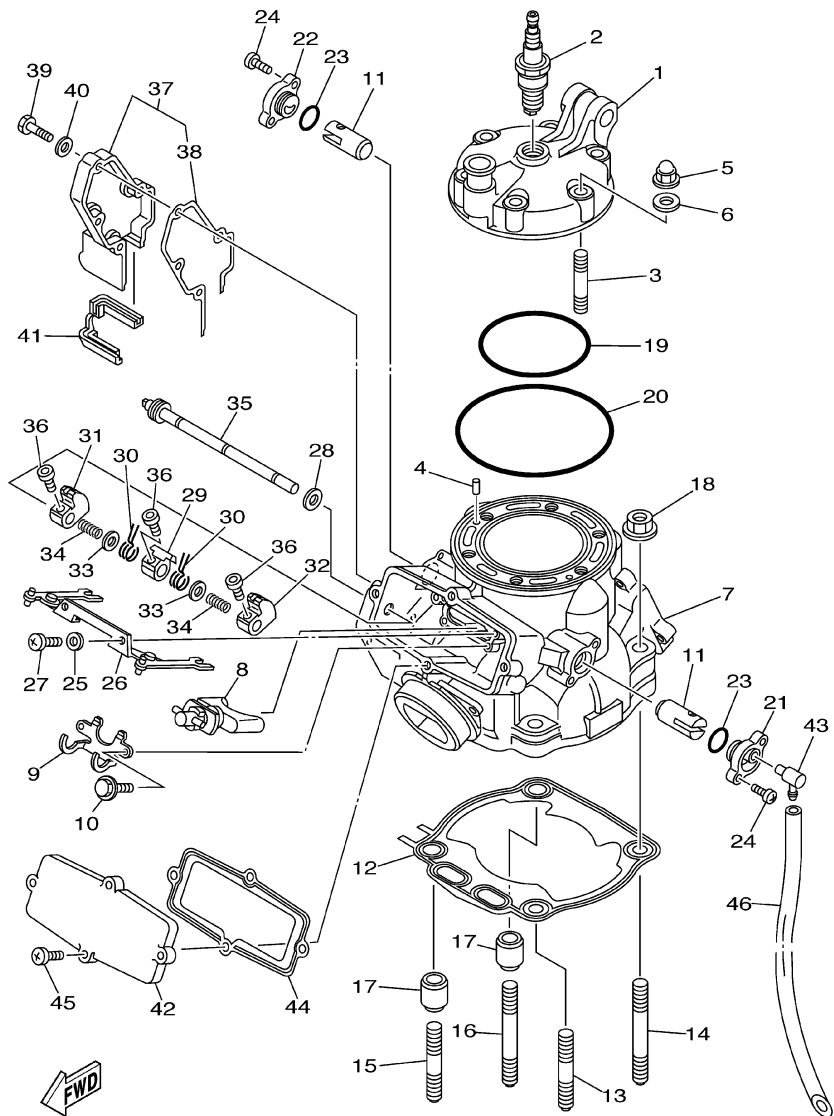

FWD
5MW1100-1010

REF. NO.	PART NO.	DESCRIPTION	5MW1	5MW2	5MW3	5MW4	REMARKS
1	5MW-11111-00	HEAD, CYLINDER 1	1	1	1	1	
2	94702-00326	PLUG, SPARK (NGK BR8EG)	1	1		1	
	94709-00326	PLUG, SPARK (NGK BR8EG)				1	
3	90116-08394	BOLT, STUD	6	6	6	6	
4	93604-08071	PIN, DOWEL	2	2	2	2	
5	90176-08026	NUT, CROWN	6	6	6	6	
6	90201-080L8	WASHER, PLATE	6	6	6	6	
7	5MW-11311-00	CYLINDER 1	1	1	1	1	
8	5CU-1131D-00	VALVE ASSY	1	1	1	1	
9	5CU-1131U-10	HOLDER 3	1	1	1	1	
10	90109-05002	BOLT	2	2	2	2	
11	5CU-1132A-00	VALVE 2	2	2	2	2	
12	5CU-11351-10	GASKET, CYLINDER	1	1	1	1	
13	90116-10314	BOLT, STUD	1	1	1	1	
14	95617-10660	BOLT, STUD	1	1	1	1	
15	90116-10314	BOLT, STUD	1	1	1	1	
16	95617-10660	BOLT, STUD	1	1	1	1	
17	99530-14016	PIN, DOWEL	2	2	2	2	
18	95707-10500	NUT, FLANGE	4	4	4	4	
19	93210-74316	O-RING	1	1	1	1	
20	93211-02703	O-RING	1	1	1	1	
21	5CU-1131E-00	HOLDER 1	1	1	1	1	
22	5CU-1131P-00	HOLDER 4	1	1	1	1	
23	93210-15639	O-RING	2	2	2	2	
24	98507-05012	SCREW, PAN HEAD	4	4	4	4	
25	90201-057H5	WASHER, PLATE	2	2	2	2	
26	5CU-11830-00	LINK ASSY	1	1	1	1	

FIG. 1 CYLINDER HEAD

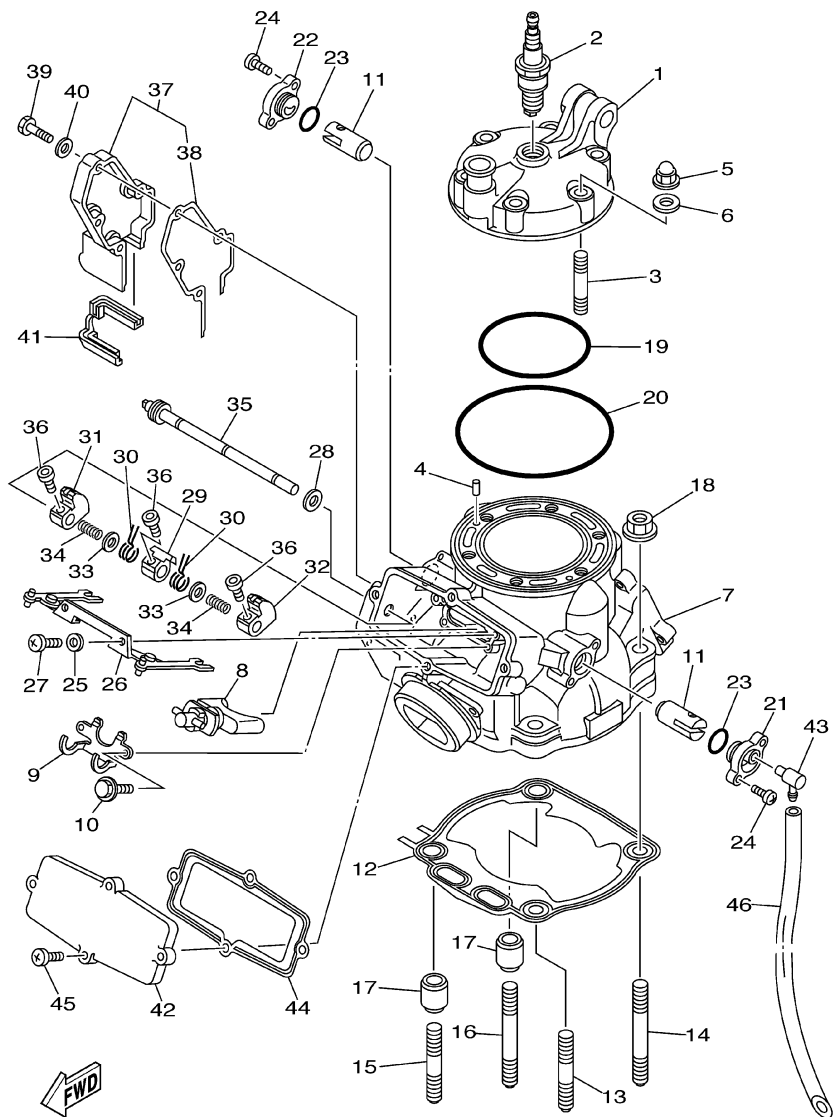

FWD
5MW1100-1010

REF. NO.	PART NO.	DESCRIPTION	5MW1	5MW2	5MW3	5MW4	REMARKS
27	98907-05012	SCREW, BIND	2	2	2	2	
28	93104-08040	OIL SEAL	1	1	1	1	
29	4SS-11832-00	LEVER, LINK	1	1	1	1	
30	90508-155B8	SPRING, TORSION	2	2	2	2	
31	5MW-1132E-00	PULLEY 1	1	1	1	1	
32	5MW-1132F-00	PULLEY 2	1	1	1	1	
33	90201-081G0	WASHER, PLATE	2	2	2	2	
34	90501-046L6	SPRING, COMPRESSION	2	2	2	2	
35	5CU-1131V-00	SHAFT 1	1	1	1	1	
36	91317-04008	BOLT	3	3	3	3	
37	5CU-11991-00	HOUSING 1	1	1	1	1	
38	5CU-11993-00	GASKET	1	1	1	1	
39	97007-05020	BOLT	4	4	4	4	
40	92907-05600	WASHER, PLATE	4	4	4	4	
41	5CU-11995-00	SEAL, HOUSING	1	1	1	1	
42	5CU-1131M-00	COVER	1	1	1	1	
43	353-13115-01	CONNECTOR, SUCTION PIPE	1	1	1	1	
44	5CU-11354-00	GASKET	1	1	1	1	
45	98907-05016	SCREW, BIND	4	4	4	4	
46	90445-09270	HOSE (L400)	1	1	1	1	

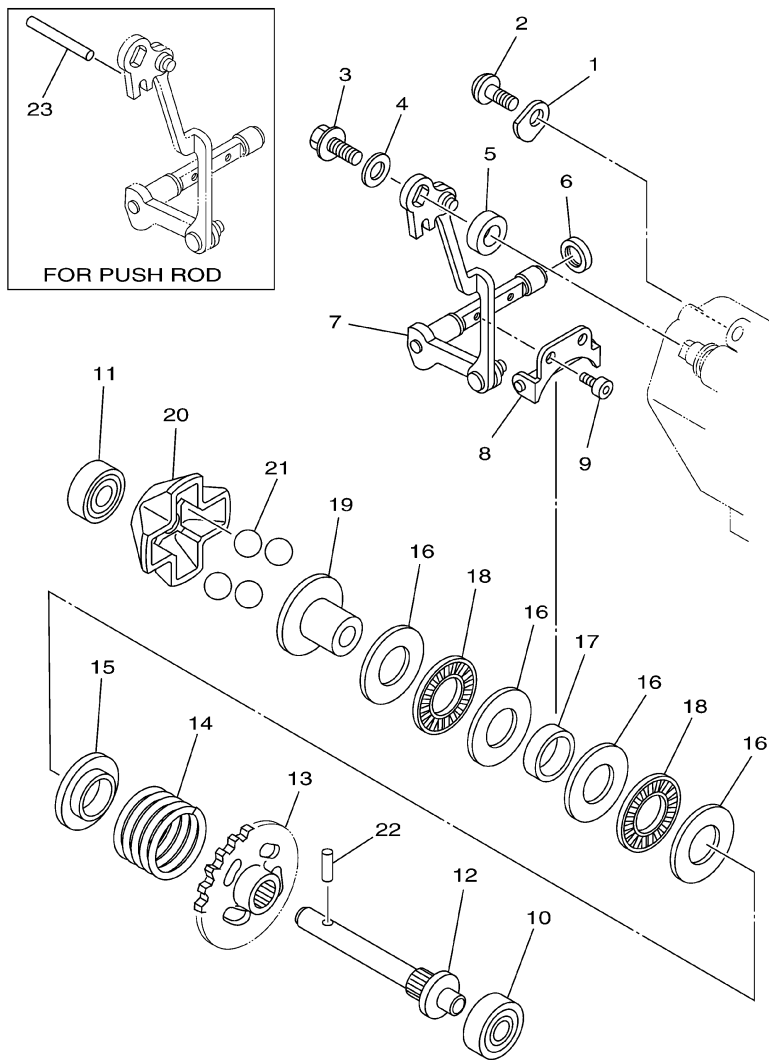

5HC1100-0020

FIG. 2 GOVERNOR

REF. NO.	PART NO.	DESCRIPTION	5MW1	5MW2	5MW3	5MW4	REMARKS
1	4JY-11915-01	PLATE, THRUST 1	1	1	1	1	
2	98907-05012	SCREW, BIND	1	1	1	1	
3	90105-05002	BOLT, FLANGE	1	1	1	1	
4	90201-057H5	WASHER, PLATE	1	1	1	1	
5	90387-085E1	COLLAR	1	1	1	1	
6	93104-08040	OIL SEAL	1	1	1	1	
7	5CU-11990-00	PUSH ROD ASSY	1	1	1	1	
8	3JE-11922-01	FORK, GOVERNOR	1	1	1	1	
9	91317-04006	BOLT	2	2	2	2	
10	93300-60801	BEARING (B0060)	1	1	1	1	KOYO
11	93300-60801	BEARING (B0060)	1	1	1	1	KOYO
12	5X4-11921-02	SHAFT, GOVERNOR	1	1	1	1	
13	24X-11953-01	GEAR, GOVERNOR	1	1	1	1	
14	90501-256L2	SPRING, COMPRESSION	1	1	1	1	
15	5CU-11952-00	PLATE	1	1	1	1	
16	90201-150U6	WASHER, PLATE	4	4	4	4	
17	90387-152F2	COLLAR	1	1	1	1	
18	93340-21505	BEARING	2	2	2	2	
19	5CU-11912-00	RETAINER, WEIGHT	1	1	1	1	
20	5CU-11911-00	RETAINER	1	1	1	1	
21	93507-16020	BALL	4	4	4	4	
22	93603-14240	PIN, DOWEL	1	1	1	1	
23	93604-29184	PIN, DOWEL	1	1	1	1	AP FOR PUSH ROD

FIG. 3 CRANKSHAFT. PISTON

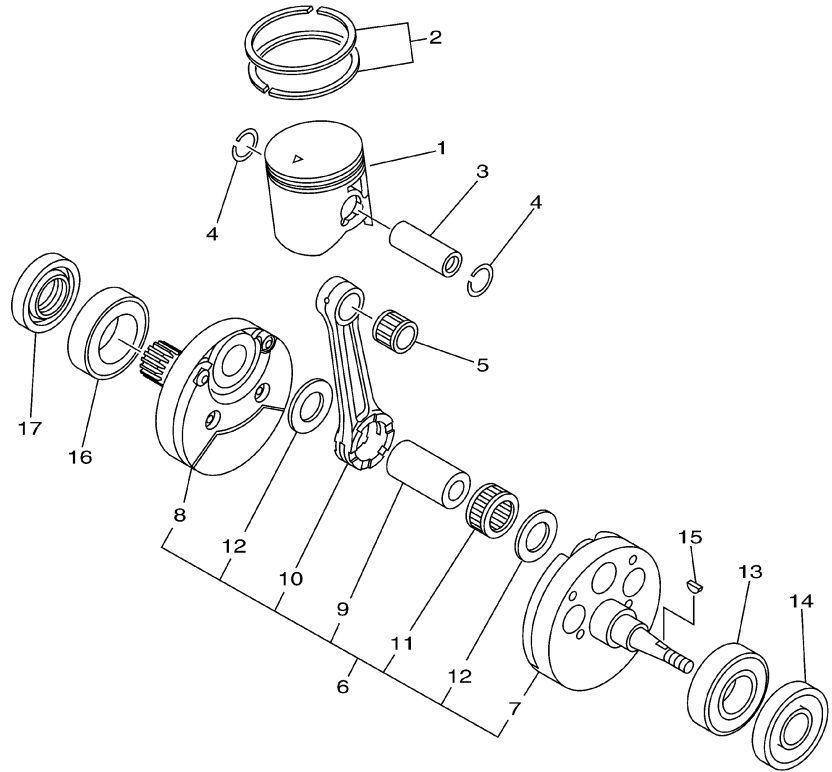

REF. NO.	PART NO.	DESCRIPTION	5MW1	5MW2	5MW3	5MW4	REMARKS
1	5MW-11631-00-A0	PISTON (STD)	1	1	1	1	UR
	5MW-11631-00-B0	PISTON (STD)	1	1	1	1	UR
	5MW-11631-00-C0	PISTON (STD)	1	1	1	1	UR
	5MW-11631-00-D0	PISTON (STD)	1	1	1	1	UR
2	5CU-11603-10	PISTON RING SET (STD)	1	1	1	1	
3	5MW-11633-00	PIN, PISTON	1	1	1	1	
4	93450-19052	CIRCLIP	2	2	2	2	
5	93310-218A6	BEARING	1	1	1	1	
6	5MW-11400-00	CRANKSHAFT ASSY	1	1	1	1	
7	5CU-11410-00	.CRANKSHAFT	1	1	1	1	
8	5MW-11420-00	.CRANKSHAFT	1	1	1	1	
9	5CU-11681-00	.PIN, CRANK 1	1	1	1	1	
10	5MW-11651-00	.ROD, CONNECTING	1	1	1	1	
11	93310-52406	.BEARING	1	1	1	1	
12	90209-24327	.WASHER	2	2	2	2	
13	93306-37808	BEARING	1	1	1	1	
14	93102-20485	OIL SEAL	1	1	1	1	
15	90280-03017	KEY, WOODRUFF	1	1	1	1	
16	93306-37808	BEARING	1	1	1	1	
17	93102-28004	OIL SEAL	1	1	1	1	



5MW1100-1030

FIG. 4 WATER PUMP

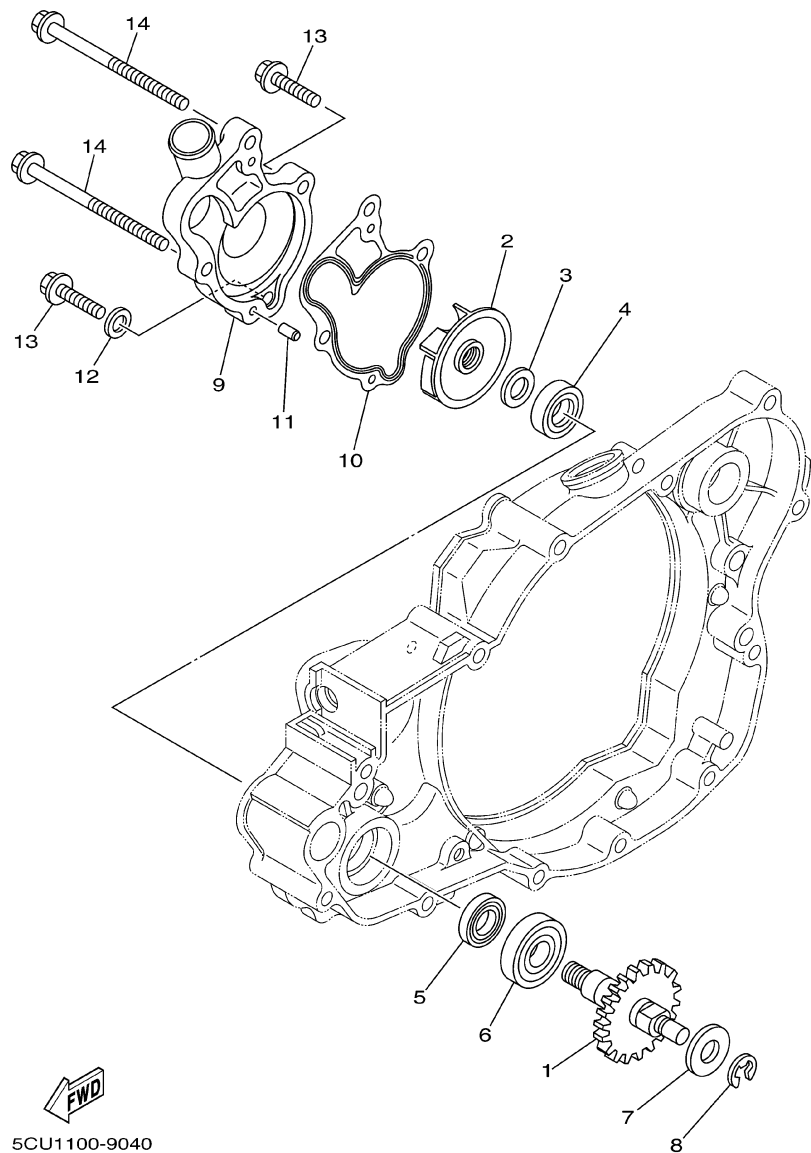

5CU1100-9040

REF. NO.	PART NO.	DESCRIPTION	5MW1	5MW2	5MW3	5MW4	REMARKS
1	5CU-12459-00	GEAR, IMPELLER SHAFT	1	1	1	1	
2	5DJ-12451-00	IMPELLER, WATER PUMP	1	1	1	1	
3	90201-08512	WASHER, PLATE	1	1	1	1	
4	93109-11073	OIL SEAL	1	1	1	1	
5	93102-12106	OIL SEAL (SD 12-22-5 HS)	1	1	1	1	
6	93306-00105	BEARING (B6001)	1	1	1	1	
7	90201-08784	WASHER, PLATE	1	1	1	1	
8	99001-06600	CIRCLIP	1	1	1	1	
9	5MW-12422-00	COVER, HOUSING	1	1	1	1	
10	5CU-12428-00	GASKET, HOUSING COVER 2	1	1	1	1	
11	93604-10011	PIN, DOWEL	2	2	2	2	
12	90430-06014	GASKET	1	1	1	1	
13	95027-06025	BOLT, FLANGE	2	2	2	2	
14	95027-06065	BOLT, FLANGE	2	2	2	2	

FIG. 5 RADIATOR. HOSE

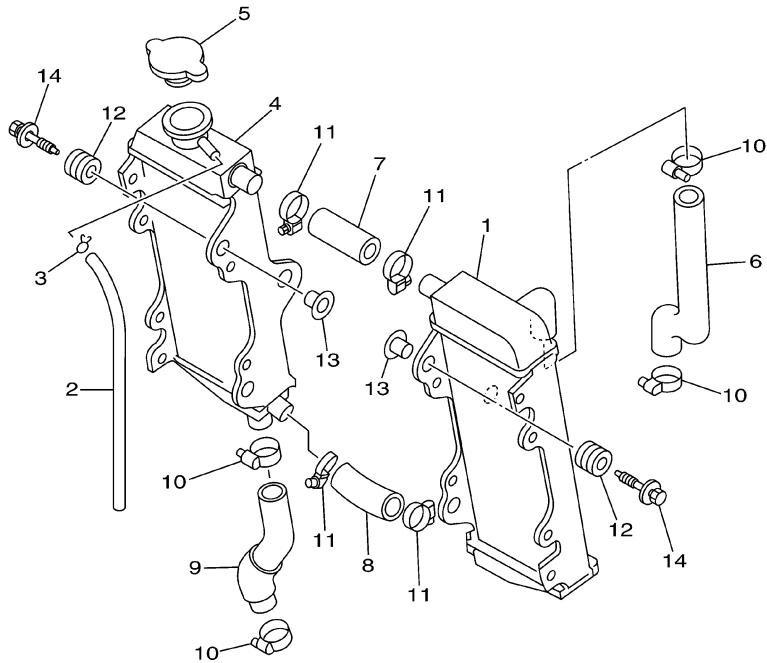

REF. NO.	PART NO.	DESCRIPTION	5MW1	5MW2	5MW3	5MW4	REMARKS
1	4SR-1240A-10	RADIATOR ASSY	1	1	1	1	
2	91A20-05065	TUBE, FLEXIBLE VINYL	1	1	1	1	
3	90467-09006	CLIP	1	1	1	1	
4	4SR-12461-10	RADIATOR ASSY	1	1	1	1	
5	5HD-12462-00	CAP, RADIATOR	1	1	1	1	
6	5CU-12481-00	PIPE 1	1	1	1	1	
7	4SS-12482-00	PIPE 2	1	1	1	1	
8	5MW-12483-00	PIPE 3	1	1	1	1	
9	5CU-12484-00	PIPE 4	1	1	1	1	
10	90450-28014	HOSE CLAMP ASSY	4	4	4	4	
11	90450-25037	HOSE CLAMP ASSY	4	4	4	4	
12	90480-15528	GROMMET	6	6	6	6	
13	90387-0614M	COLLAR	6	6	6	6	
14	90119-06214	BOLT, WITH WASHER	6	6	6	6	



5MW1100-1050

FIG. 6 INTAKE

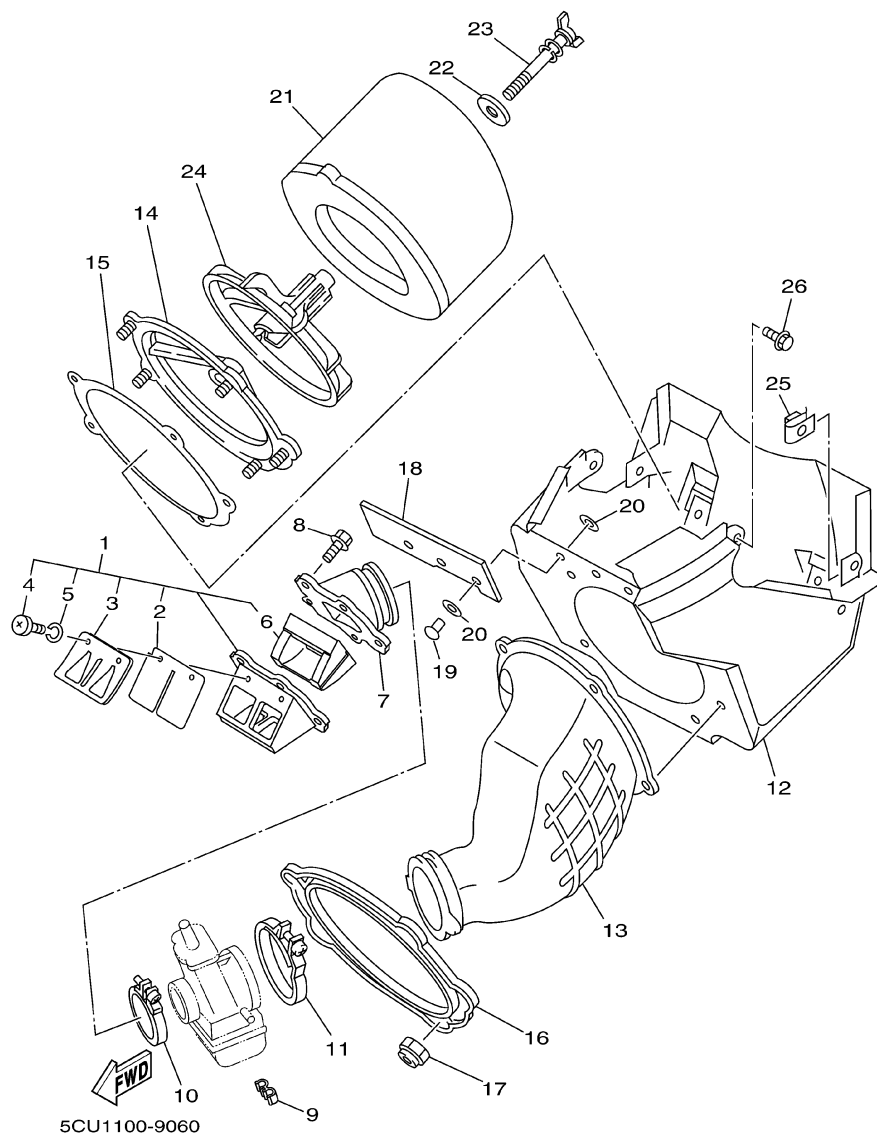

REF. NO.	PART NO.	DESCRIPTION	5MW1	5MW2	5MW3	5MW4	REMARKS
1	4XL-13610-00	REED VALVE ASSY	1	1	1	1	
2	4XL-13613-00	.REED, VALVE	2	2	2	2	
3	4XL-13616-00	.STOPPER, REED VALVE	2	2	2	2	
4	98507-03008	.SCREW, PAN HEAD	4	4	4	4	
5	92907-03100	.WASHER	4	4	4	4	
6	4XL-13625-00	.SPACER, REED VALVE	1	1	1	1	
7	5HC-13565-00	JOINT, CARBURETOR	1	1	1	1	
8	91317-06020	BOLT	5	5	5	5	
9	90464-06214	CLAMP	2	2	2	2	
10	90450-51070	HOSE CLAMP ASSY	1	1	1	1	
11	90450-70072	HOSE CLAMP ASSY	1	1	1	1	
12	4SS-14401-10	AIR CLEANER CASE ASSY	1	1	1	1	
13	5HC-14453-00	JOINT, AIR CLEANER 1	1	1	1	1	
14	3JD-14459-01	HOLDER, GUIDE	1	1	1	1	
15	3JD-14462-00	SEAL	1	1	1	1	
16	5MV-14477-00	PLATE	1	1	1	1	
17	95607-05100	NUT, U	5	5	5	5	
18	4SS-14417-00	COVER 1	1	1	1	1	
19	90267-32070	RIVET, BLIND	3	3	3	3	
20	90201-03313	WASHER, PLATE	6	6	6	6	
21	4XM-14451-00	ELEMENT, AIR CLEANER	1	1	1	1	
22	90209-06096	WASHER	1	1	1	1	
23	90122-06035	BOLT, WING	1	1	1	1	
24	3JD-14458-01	GUIDE	1	1	1	1	
25	90183-06023	NUT, SPRING	4	4	4	4	
26	90119-06203	BOLT, WITH WASHER	2	2	2	2	

FIG. 7 CARBURETOR

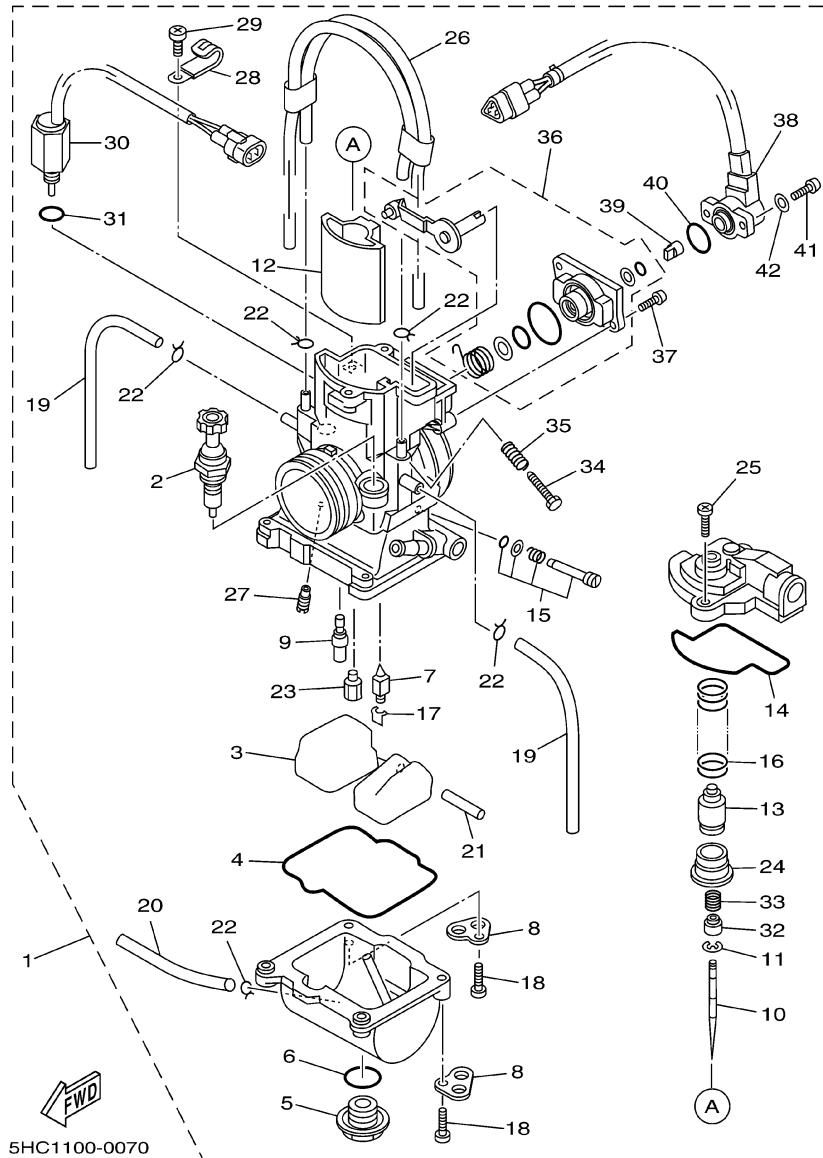

REF. NO.	PART NO.	DESCRIPTION	5MW1	5MW2	5MW3	5MW4	REMARKS
1	5MW-14101-00	CARBURETOR ASSY 1	1			1	
	5MW-14101-10	CARBURETOR ASSY 1		1			
	5MW-14101-20	CARBURETOR ASSY 1			1		
2	4JT-14171-00	.PLUNGER, STARTER	1	1	1	1	
3	4SR-14985-00	.FLOAT	1	1	1	1	
4	4JT-14984-00	.GASKET, FLOAT CHAMBER	1	1	1	1	
5	4MX-14115-00	.PLUG, SCREW	1	1	1	1	
6	4MX-14561-00	.O-RING	1	1	1	1	
7	4MX-14392-00	.VALVE, NEEDLE	1	1	1	1	
8	4XL-14146-00	.PLATE	2	2	2	2	
9	4MX-14948-07	.JET, SLOW (#50)	1		1	1	STD
	4MX-14948-09	.JET, SLOW (#55)		1			STD
	4SR-14948-02	.JET, SLOW (#38)	1	1	1	1	AP
	4SR-14948-03	.JET, SLOW (#40)	1	1	1	1	AP
	4MX-14948-04	.JET, SLOW (#42)	1	1	1	1	AP
	4MX-14948-05	.JET, SLOW (#45)	1	1	1	1	AP
	4MX-14948-06	.JET, SLOW (#48)	1	1	1	1	AP
	4MX-14948-07	.JET, SLOW (#50)		1			AP
	4MX-14948-08	.JET, SLOW (#52)	1	1	1	1	AP
	4MX-14948-09	.JET, SLOW (#55)	1		1	1	AP
	4MX-14948-10	.JET, SLOW (#58)	1	1	1	1	AP
	4MX-14948-11	.JET, SLOW (#60)	1	1	1	1	AP
	4MX-14948-12	.JET, SLOW (#62)	1	1	1	1	AP
10	4SR-14916-CJ	.NEEDLE (N3CJ)			1		STD
	4SR-14916-CW	.NEEDLE (N3CW)			1		STD
	4SR-14916-EJ	.NEEDLE (N3EJ)	1			1	STD
	4JT-14916-9G	.NEEDLE (N89G)	1	1	1	1	AP

FIG. 7 CARBURETOR

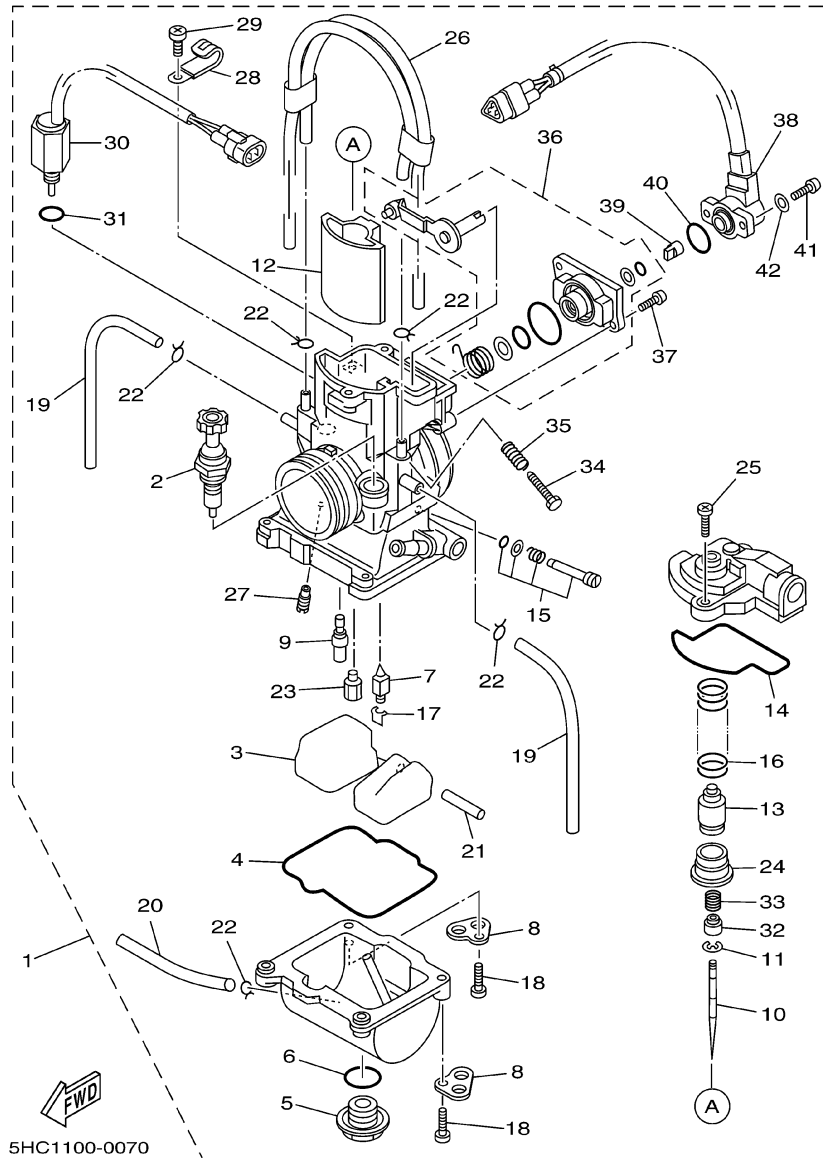

5HC1100-0070

REF. NO.	PART NO.	DESCRIPTION	5MW1	5MW2	5MW3	5MW4	REMARKS
10	4JT-14916-9H	.NEEDLE (N89H)	1	1	1	1	AP
	4JT-14916-9W	.NEEDLE (N89W)	1	1	1	1	AP
	4JT-14916-9J	.NEEDLE (N89J)	1	1	1	1	AP
	4SR-14916-CG	.NEEDLE (N3CG)	1	1	1	1	AP
	4SR-14916-CH	.NEEDLE (N3CH)	1	1	1	1	AP
	4SR-14916-CJ	.NEEDLE (N3CJ)	1	1		1	AP
	4SR-14916-CW	.NEEDLE (N3CW)	1		1	1	AP
	4SR-14916-EG	.NEEDLE (N3EG)	1	1	1	1	AP
	4SR-14916-EH	.NEEDLE (N3EH)	1	1	1	1	AP
	4SR-14916-EW	.NEEDLE (N3EW)	1	1	1	1	AP
	4SR-14916-EJ	.NEEDLE (N3EJ)		1	1		AP
11	4MX-14919-00	.CLIP	1	1	1	1	
12	5HC-14340-A7	.VALVE ASSY	1	1	1	1	
13	5HC-14261-00	.HOLDER	1	1	1	1	
14	5HC-14126-00	.GASKET	1	1	1	1	
15	4SR-14105-00	.PILOT SCREW SET	1	1	1	1	
16	5HC-14131-00	.SPRING, THROTTLE VALVE	1	1	1	1	
17	663-14159-00	.CLIP	1	1	1	1	
18	98502-04014	.SCREW, PAN HEAD	4	4	4	4	
19	4XL-14197-10	.PIPE	2	2	2	2	
20	4XL-14196-10	.PIPE	1	1	1	1	
21	676-14548-00	.PIN, FLOAT ARM	1	1	1	1	
22	3TJ-14137-40	.CLIP	5	5	5	5	
23	4MX-14943-43	.JET, MAIN (#180)		1	1		STD
	4MX-14943-93	.JET, MAIN (#178)	1			1	STD
	4SR-14943-90	.JET, MAIN (#162)	1	1	1	1	AP
	4MX-14943-40	.JET, MAIN (#165)	1	1	1	1	AP

FIG. 7 CARBURETOR

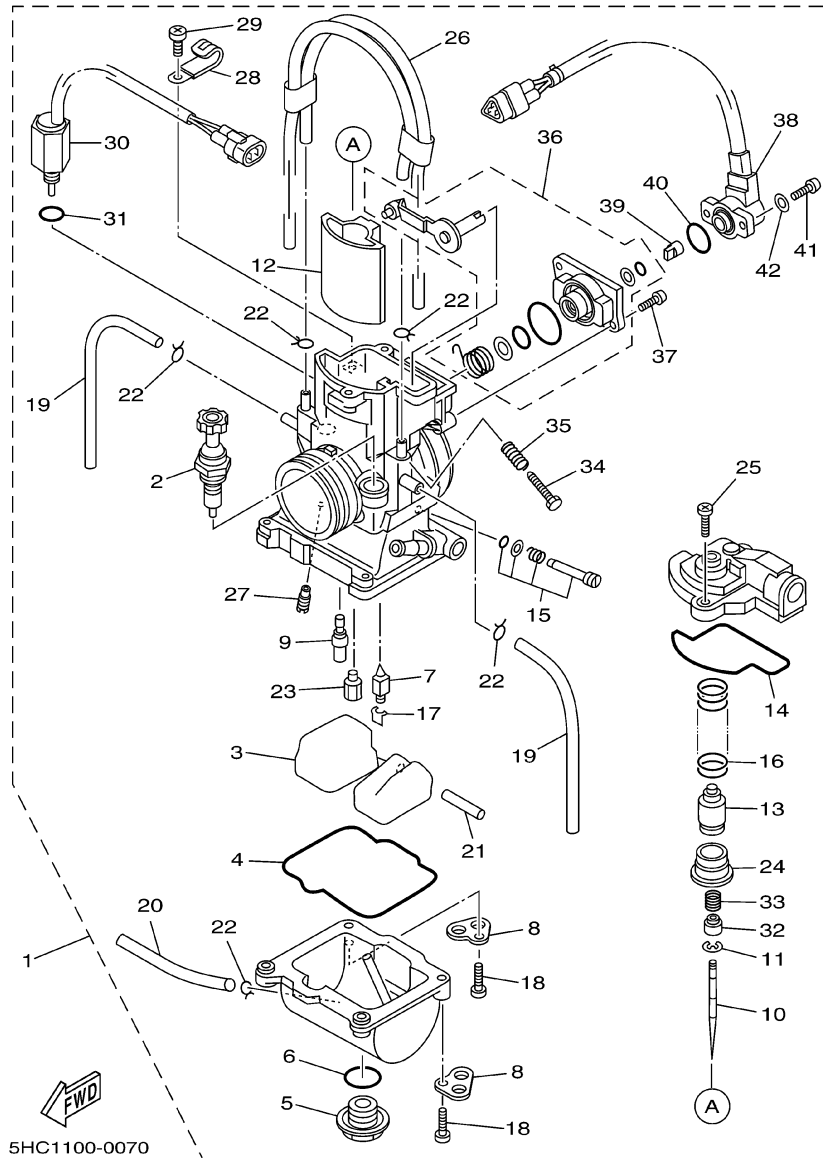

REF. NO.	PART NO.	DESCRIPTION	5MW1	5MW2	5MW3	5MW4	REMARKS
23	4MX-14943-91	.JET, MAIN (#168)	1	1	1	1	AP
	4MX-14943-41	.JET, MAIN (#170)	1	1	1	1	AP
	4MX-14943-92	.JET, MAIN (#172)	1	1	1	1	AP
	4MX-14943-42	.JET, MAIN (#175)	1	1	1	1	AP
	4MX-14943-43	.JET, MAIN (#180)	1				AP
	4MX-14943-93	.JET, MAIN (#178)		1	1		AP
	4MX-14943-94	.JET, MAIN (#182)	1	1	1	1	AP
	4MX-14943-44	.JET, MAIN (#185)	1	1	1	1	AP
	4MX-14943-95	.JET, MAIN (#188)	1	1	1	1	AP
	4MX-14943-45	.JET, MAIN (#190)	1	1	1	1	AP
24	4MX-14194-00	.RING	1	1	1	1	
25	98502-04012	.SCREW, PAN HEAD	2	2	2	2	
26	4XL-1410E-00	.HOSE	1	1	1	1	
27	4JT-1494F-07	.JET (#50)	1			1	STD
	4JT-1494F-09	.JET (#55)		1	1		STD
	4JT-1494F-09	.JET (#55)	1			1	AP
	4JT-1494F-13	.JET (#65)	1	1	1	1	AP
	4JT-1494F-15	.JET (#70)	1	1	1	1	AP
	4JT-1494F-07	.JET (#50)		1	1		AP
	4JT-1494F-11	.JET (#60)	1	1	1	1	AP
28	5HC-14146-00	.PLATE	1	1	1	1	
29	98580-04006	.SCREW, PAN HEAD	1	1	1	1	
30	5HC-1410H-00	.FUEL CUT SOLENOID VALVE	1	1	1	1	
31	4JT-14147-00	.O-RING	1	1	1	1	
32	5HC-14264-00	.COLLAR	1	1	1	1	
33	5HC-14275-00	.SPRING	1	1	1	1	
34	5HC-14922-00	.SCREW, THROTTLE	1	1	1	1	

FIG. 7 CARBURETOR

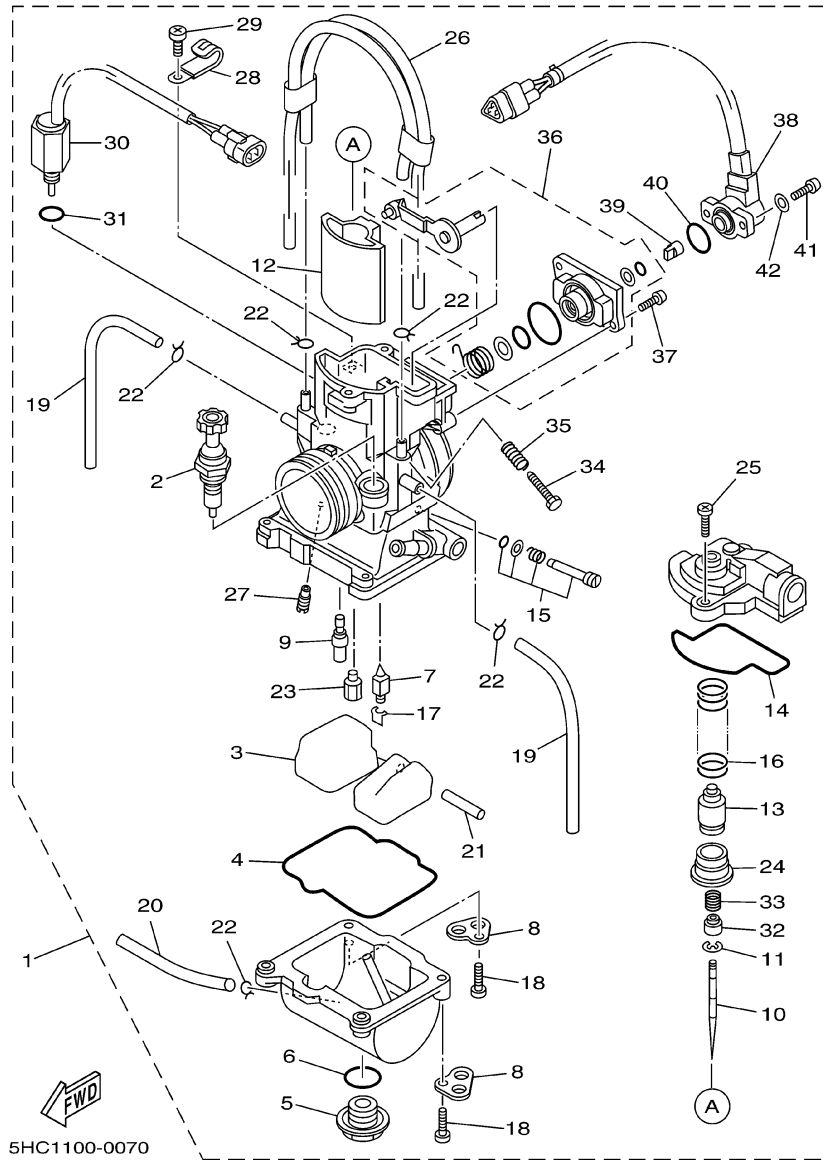

5HC1100-0070

REF. NO.	PART NO.	DESCRIPTION	5MW1	5MW2	5MW3	5MW4	REMARKS
35	5HC-14934-00	.SPRING, THROTTLE STOP	1	1	1	1	
36	5HC-14208-00	.LEVER COMP. 1	1	1	1	1	
37	5HC-14216-00	.SCREW	2	2	2	2	
38	5HC-85885-00	.THROTTLE SENSOR ASSY	1	1	1	1	
39	5BE-14449-00	.COLLAR	1	1	1	1	
40	5BE-14562-00	.O-RING	1	1	1	1	
41	4YR-14216-00	.SCREW	2	2	2	2	
42	4YR-14557-00	.WASHER	2	2	2	2	

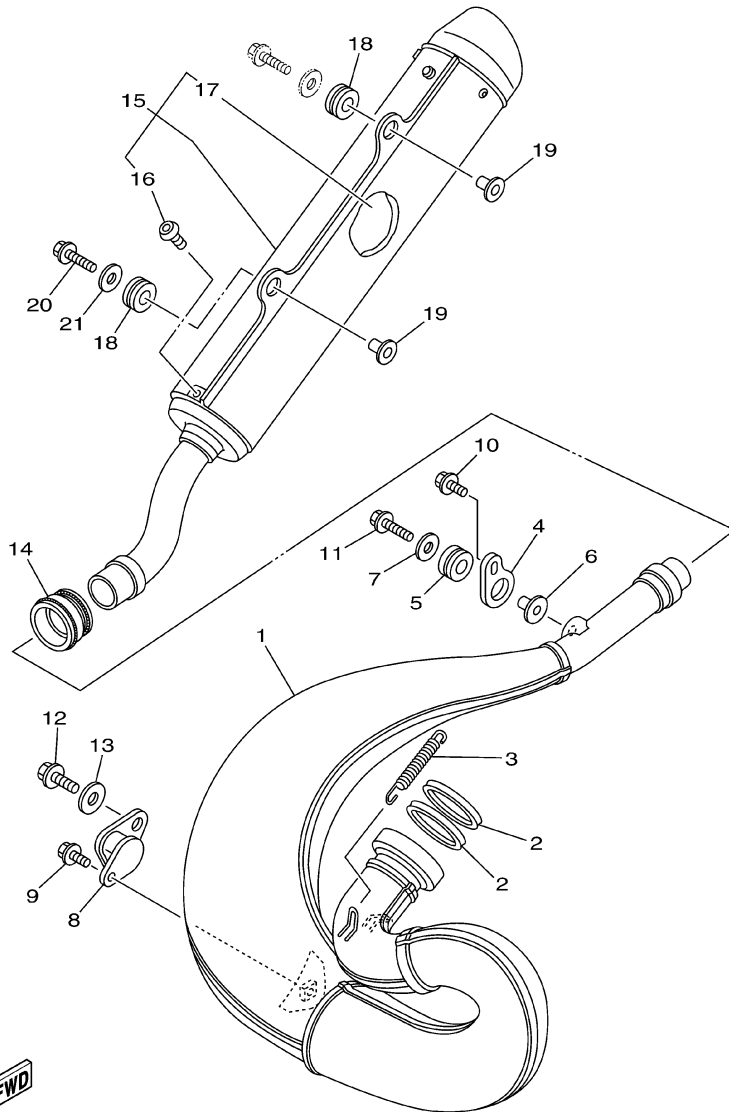

5MW1100-1080

FIG. 8 EXHAUST

REF. NO.	PART NO.	DESCRIPTION	5MW1	5MW2	5MW3	5MW4	REMARKS
1	5MW-14610-00	EXHAUST PIPE ASSY 1	1	1	1	1	UR
	5MW-14610-10	EXHAUST PIPE ASSY 1	1				UR FOR USA
2	5MW-14642-00	SEAL, EXHAUST	2	2	2	2	
3	90507-20052	SPRING, TENSION	2	2	2	2	
4	5CU-14771-00	STAY, MUFFLER 1	1	1	1	1	
5	90480-16561	GROMMET	1	1	1	1	
6	90387-063G3	COLLAR	1	1	1	1	
7	90201-06071	WASHER, PLATE	1	1	1	1	
8	483-14781-02	STAY, MUFFLER 2	1	1	1	1	
9	95027-06012	BOLT, FLANGE	1	1	1	1	
10	90119-06192	BOLT, WITH WASHER	1	1	1	1	
11	95027-06025	BOLT, FLANGE	1	1	1	1	
12	95027-08012	BOLT, FLANGE	1	1	1	1	
13	90201-08730	WASHER, PLATE	1	1	1	1	
14	3JE-14615-01	JOINT, EXHAUST 1	1	1	1	1	
15	5HC-14753-00	SILENCER, EXHAUST	1	1	1	1	UR
	5MW-14753-10	SILENCER, EXHAUST	1				UR FOR USA
16	92017-06010	.BOLT, BUTTON HEAD	2	2	2	2	
17	5CU-1469A-00	.FIBER	1	1	1	1	UR
	5HC-1469A-10	.FIBER	1				UR FOR USA
18	90480-16561	GROMMET	2	2	2	2	
19	90387-063G3	COLLAR	2	2	2	2	
20	95027-06025	BOLT, FLANGE	1	1	1	1	
21	90201-06071	WASHER, PLATE	1	1	1	1	

FIG. 9 CRANKCASE

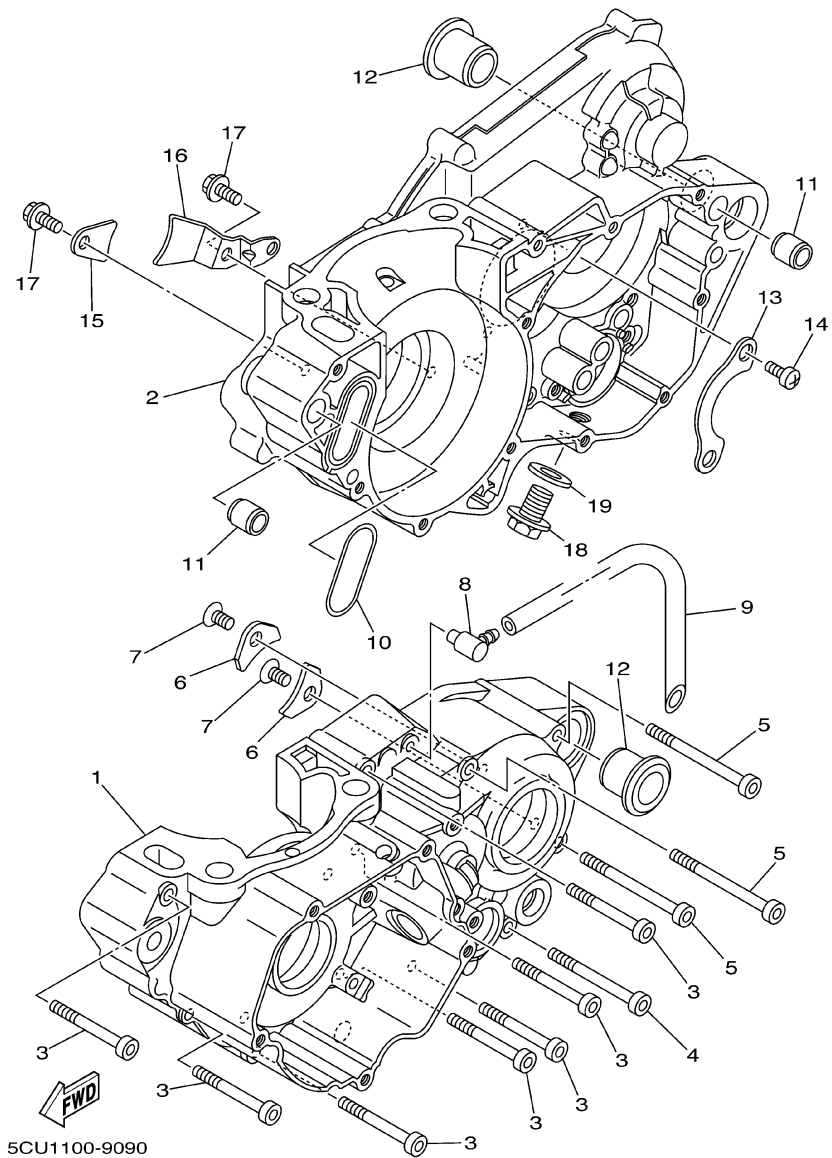

5CU1100-9090

REF. NO.	PART NO.	DESCRIPTION	5MW1	5MW2	5MW3	5MW4	REMARKS	
	1	5CU-15111-01	CRANKCASE 1	1	1	1	1	
	2	5CU-15121-01	CRANKCASE 2	1	1	1	1	
	3	91317-06050	BOLT	7	7	7	7	
	4	91317-06060	BOLT	1	1	1	1	
	5	91317-06070	BOLT	3	3	3	3	
	6	4JT-15381-01	PLATE, BEARING COVER	2	2	2	2	
	7	90149-06326	SCREW	2	2	2	2	
	8	353-13115-01	CONNECTOR, SUCTION PIPE	1	1	1	1	
	9	90445-08605	HOSE	1	1	1	1	
	10	5CU-15454-00	GASKET, AIR CLEANER COVER 1	1	1	1	1	
	11	93612-16254	PIN, DOWEL	2	2	2	2	
	12	90387-1712Y	COLLAR	2	2	2	2	
	13	4L0-17471-00	PLATE, COVER	1	1	1	1	
	14	90157-06077	SCREW, PAN HEAD	2	2	2	2	
	15	4V4-15118-00	HOLDER	1	1	1	1	
	16	5CU-15118-00	HOLDER	1	1	1	1	
	17	90105-06556	BOLT, FLANGE	2	2	2	2	
	18	90340-12059	PLUG, STRAIGHT SCREW	1	1	1	1	
	19	90430-12227	GASKET	1	1	1	1	

FIG. 10 CRANKCASE COVER 1

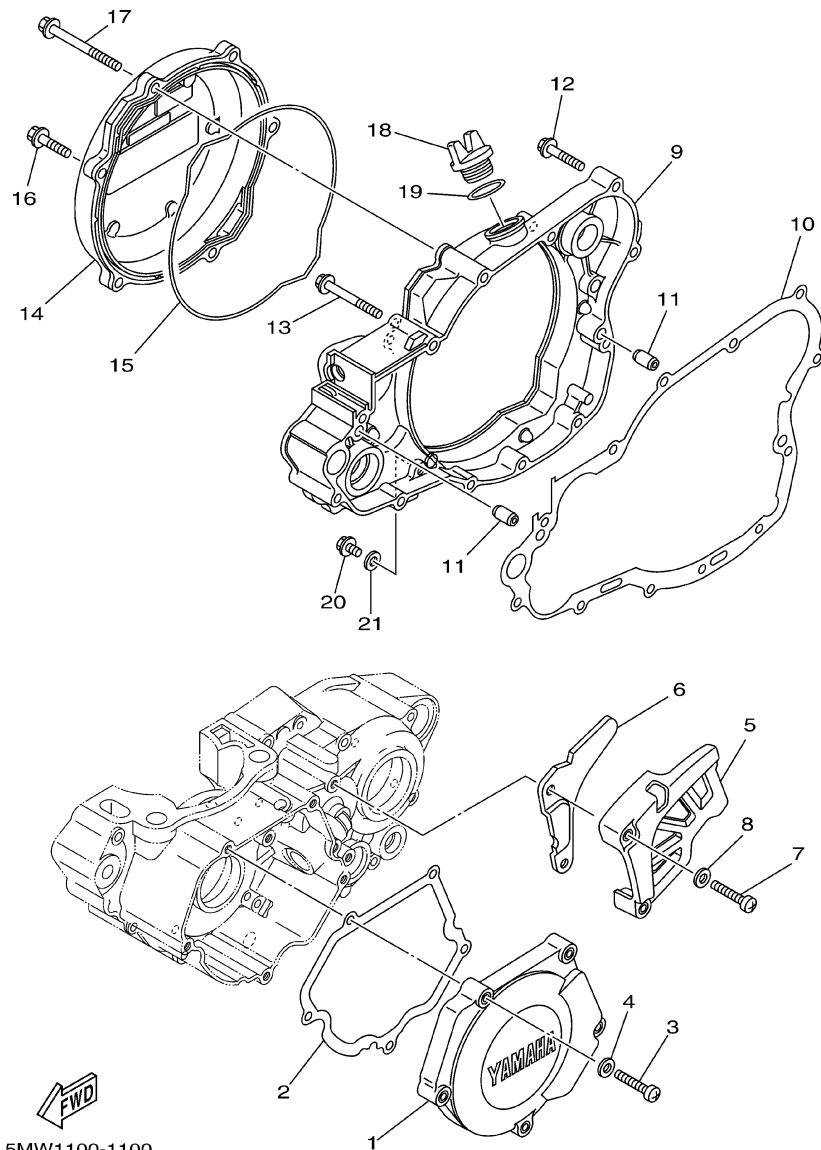

REF. NO.	PART NO.	DESCRIPTION	5MW1	5MW2	5MW3	5MW4	REMARKS
1	5CU-15411-00	COVER, CRANKCASE 1	1	1	1	1	
2	5CU-15451-00	GASKET, CRANKCASE COVER 1	1	1	1	1	
3	98507-06030	SCREW, PAN HEAD	5	5	5	5	
4	92907-06600	WASHER, PLATE	5	5	5	5	
5	5CU-15421-00	COVER, CRANKCASE 2	1	1	1	1	
6	5HC-17466-00	GUIDE, CHAIN	1	1	1	1	
7	98507-06035	SCREW, PAN HEAD	2	2	2	2	
8	92907-06600	WASHER, PLATE	2	2	2	2	
9	5CU-15431-00	COVER, CRANKCASE 3	1	1	1	1	
10	5CU-15462-00	GASKET, CRANKCASE COVER 3	1	1	1	1	
11	99530-08016	PIN, DOWEL	2	2	2	2	
12	95027-06030	BOLT, FLANGE	8	8	8	8	
13	95027-06050	BOLT, FLANGE	1	1	1	1	
14	5MW-15415-00	COVER, GENERATOR	1	1	1	1	
15	5CU-15463-00	GASKET, CARBURETOR COVER 2	1	1	1	1	
16	95027-06025	BOLT, FLANGE	5	5	5	5	
17	95027-06065	BOLT, FLANGE	1	1	1	1	
18	3Y1-15363-00	PLUG, OIL	1	1	1	1	
19	93210-19123	O-RING	1	1	1	1	
20	95027-06010	BOLT, FLANGE	1	1	1	1	
21	90430-06014	GASKET	1	1	1	1	

FIG. 11 STARTER

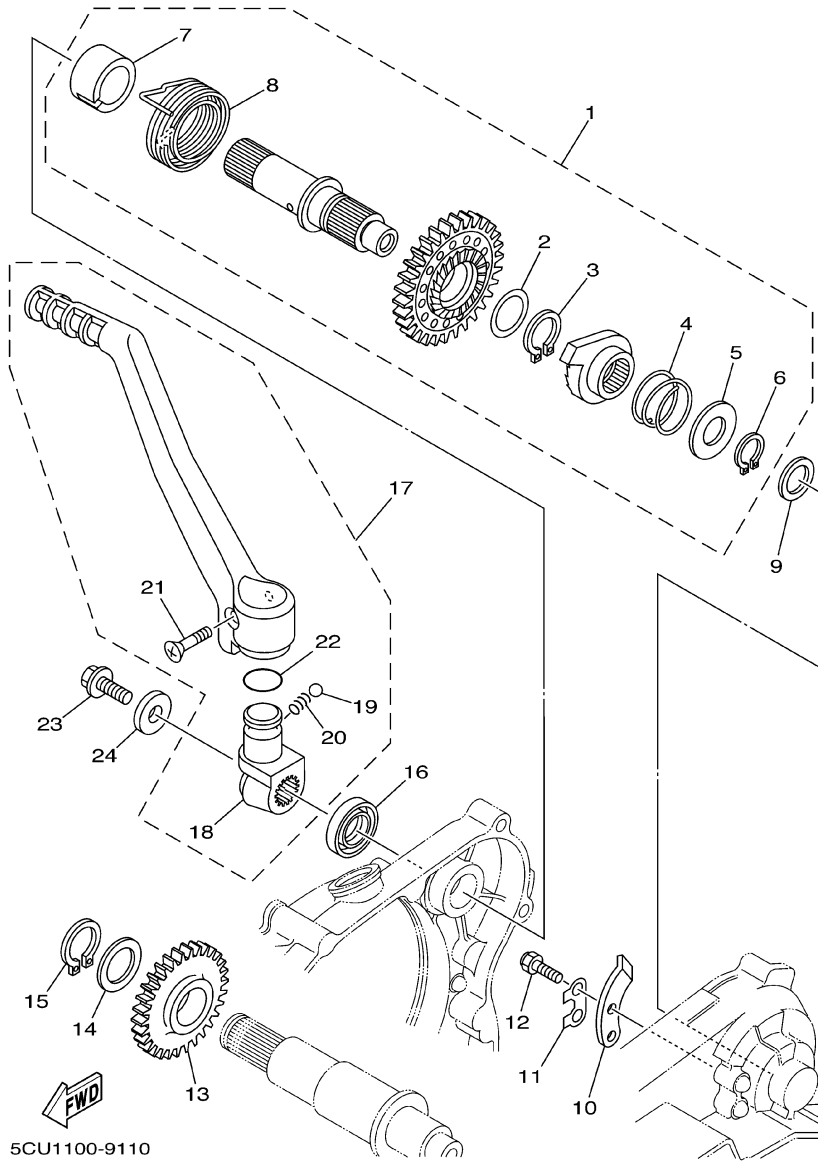

5CU1100-9110

REF. NO.	PART NO.	DESCRIPTION	5MW1	5MW2	5MW3	5MW4	REMARKS
1	5CU-15601-01	KICK SHAFT ASSY	1	1	1	1	
2	90201-20685	.WASHER, PLATE (0.5T)	1	1	1	1	
3	93410-20038	.CIRCLIP	1	1	1	1	
*4	90501-16016	.SPRING, COMPRESSION	1	1	1	1	
5	90201-167P7	.WASHER, PLATE	1	1	1	1	
6	99009-16400	.CIRCLIP	1	1	1	1	
7	5CU-15664-00	.GUIDE, SPRING	1	1	1	1	
8	90508-305B0	.SPRING, TORSION	1	1	1	1	
9	90201-162H4	WASHER, PLATE	1	1	1	1	
10	3Y6-15674-00	GUIDE, RATCHET WHEEL	1	1	1	1	
11	214-15686-00	WASHER, LOCK	1	1	1	1	
12	97027-06016	BOLT	2	2	2	2	
13	5CU-15651-00	GEAR, KICK IDLE	1	1	1	1	
14	90201-20276	WASHER, PLATE (1.0T)	1	1	1	1	
15	99009-20400	CIRCLIP	1	1	1	1	
16	93102-20484	OIL SEAL	1	1	1	1	
17	4EW-15620-02	KICK CRANK ASSY	1	1	1	1	
18	3SP-15621-02	.BOSS, KICK CRANK	1	1	1	1	
19	93501-04011	.BALL	1	1	1	1	
20	90501-13720	.SPRING, COMPRESSION	1	1	1	1	
21	90152-06010	.SCREW, COUNTERSUNK	1	1	1	1	
22	93210-19216	.O-RING	1	1	1	1	
23	95027-08020	BOLT, FLANGE	1	1	1	1	
24	90201-087A9	WASHER, PLATE	1	1	1	1	

FIG. 12 CLUTCH

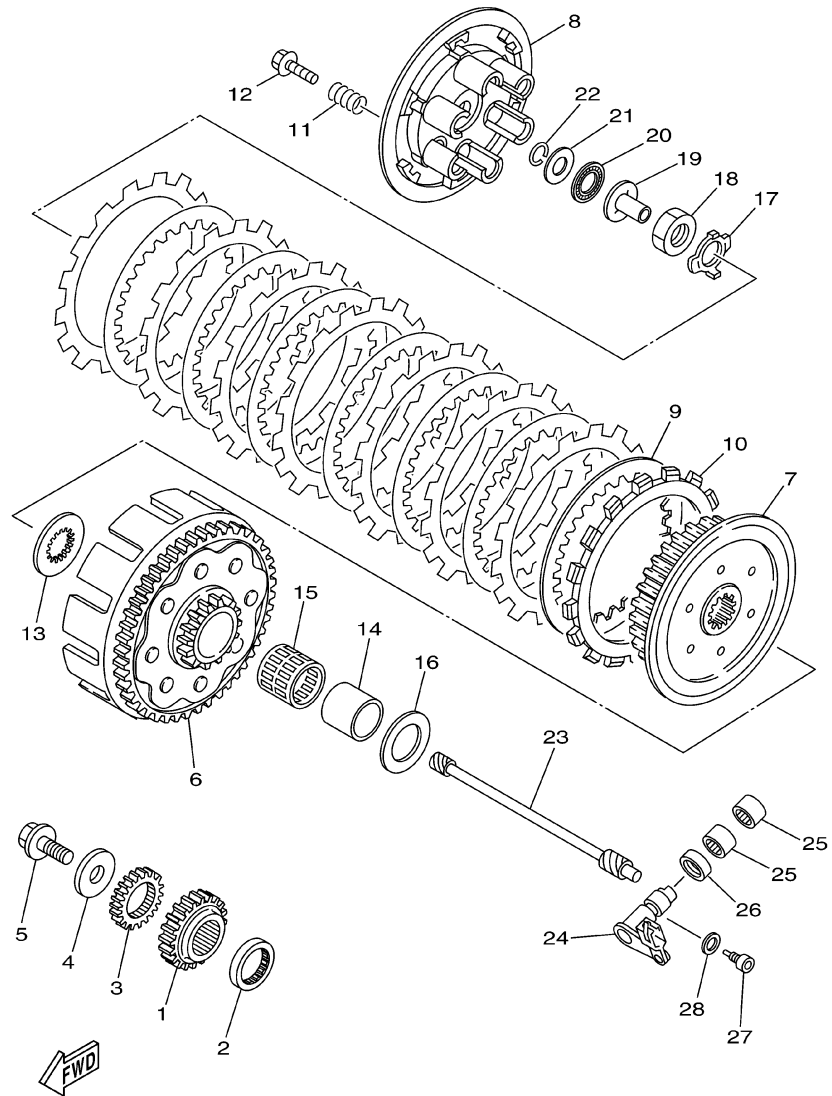

5MW1100-1120

REF. NO.	PART NO.	DESCRIPTION	5MW1	5MW2	5MW3	5MW4	REMARKS
1	5DJ-16111-00	GEAR, PRIMARY DRIVE	1	1	1	1	
2	5MW-16113-00	WASHER, THRUST 1	1	1	1	1	
3	5CU-11956-00	GEAR, GOVERNOR DRIVE	1	1	1	1	
4	90201-105P3	WASHER, PLATE	1	1	1	1	
5	90105-10445	BOLT, FLANGE	1	1	1	1	
6	5DJ-16150-00	PRIMARY DRIVEN GEAR COMP.	1	1	1	1	
7	4EW-16371-01	BOSS, CLUTCH	1	1	1	1	
8	5HC-16351-00	PLATE, PRESSURE 1	1	1	1	1	
9	4X7-16325-00	PLATE, CLUTCH 2	7	7	7	7	
10	3XK-16321-00	PLATE, FRICTION	8	8	8	8	
11	90501-23141	SPRING, COMPRESSION	6	6	6	6	
12	90159-06016	SCREW, WITH WASHER	6	6	6	6	
13	5CU-16154-00	PLATE, THRUST 1	1	1	1	1	
14	2VM-16181-00	SPACER 1	1	1	1	1	
15	93310-230T7	BEARING	1	1	1	1	
16	2K7-16154-00	PLATE, THRUST 1	1	1	1	1	
17	90215-20231	WASHER, LOCK	1	1	1	1	
18	90170-20255	NUT	1	1	1	1	
19	4XL-16356-00	ROD, PUSH 1	1	1	1	1	
20	93340-21505	BEARING	1	1	1	1	
21	90201-125L6	WASHER, PLATE	1	1	1	1	
22	93440-10085	CIRCLIP	1	1	1	1	
23	5CU-16357-10	ROD, PUSH 2	1	1	1	1	
24	5CU-16380-10	PUSH LEVER ASSY	1	1	1	1	
25	93315-11206	BEARING	2	2	2	2	
26	93102-12224	OIL SEAL	1	1	1	1	
27	90109-056G0	BOLT	1	1	1	1	

FIG. 13 TRANSMISSION

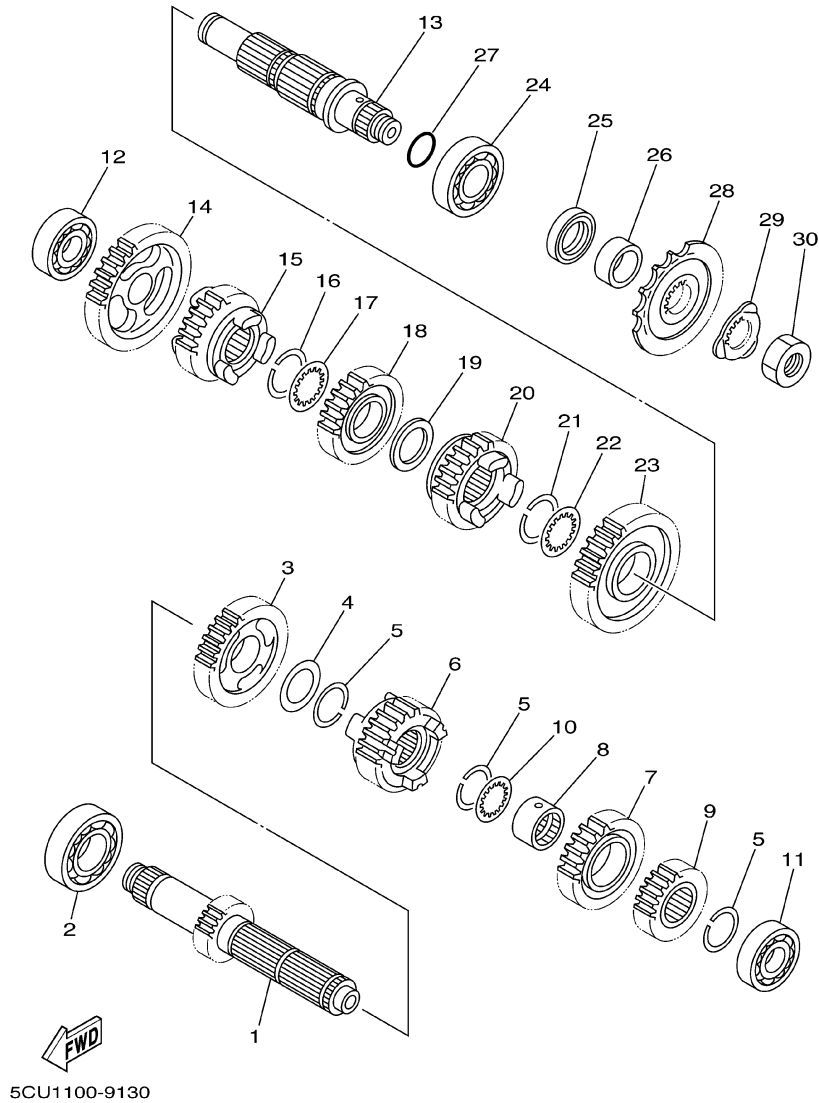

REF. NO.	PART NO.	DESCRIPTION	5MW1	5MW2	5MW3	5MW4	REMARKS
1	5BE-17411-00	AXLE, MAIN	1	1	1	1	
2	93306-20540	BEARING	1	1	1	1	
3	5BE-17151-00	GEAR, 5TH PINION (21T)	1	1	1	1	
4	90201-253K0	WASHER, PLATE (T=1.0)	1	1	1	1	
5	93440-25084	CIRCLIP	3	3	3	3	
6	5CU-17131-00	GEAR, 3RD PINION (18T)	1	1	1	1	
7	5BE-17141-20	GEAR, 4TH PINION (22T)	1	1	1	1	
8	90387-2113G	COLLAR	1	1	1	1	
9	5BE-17121-00	GEAR, 2ND PINION (16T)	1	1	1	1	
10	90209-21332	WASHER	1	1	1	1	
11	93306-00442	BEARING	1	1	1	1	
12	93306-00426	BEARING	1	1	1	1	
13	5BE-17421-00	AXLE, DRIVE	1	1	1	1	
14	5BE-17211-00	GEAR, 1ST WHEEL (27T)	1	1	1	1	
15	5BE-17251-10	GEAR, 5TH WHEEL (20T)	1	1	1	1	
16	93440-25084	CIRCLIP	1	1	1	1	
17	90209-21332	WASHER	1	1	1	1	
18	5BE-17231-00	GEAR, 3RD WHEEL (23T)	1	1	1	1	
19	90201-253K0	WASHER, PLATE (T=1.0)	1	1	1	1	
20	5BE-17241-10	GEAR, 4TH WHEEL (24T)	1	1	1	1	
21	93440-28062	CIRCLIP	1	1	1	1	
22	90209-26348	WASHER	1	1	1	1	
23	5BE-17221-00	GEAR, 2ND WHEEL (25T)	1	1	1	1	
24	93306-20574	BEARING	1	1	1	1	
25	93102-32337	OIL SEAL	1	1	1	1	
26	90387-2515B	COLLAR	1	1	1	1	
27	93210-22298	O-RING	1	1	1	1	

FIG. 13 TRANSMISSION

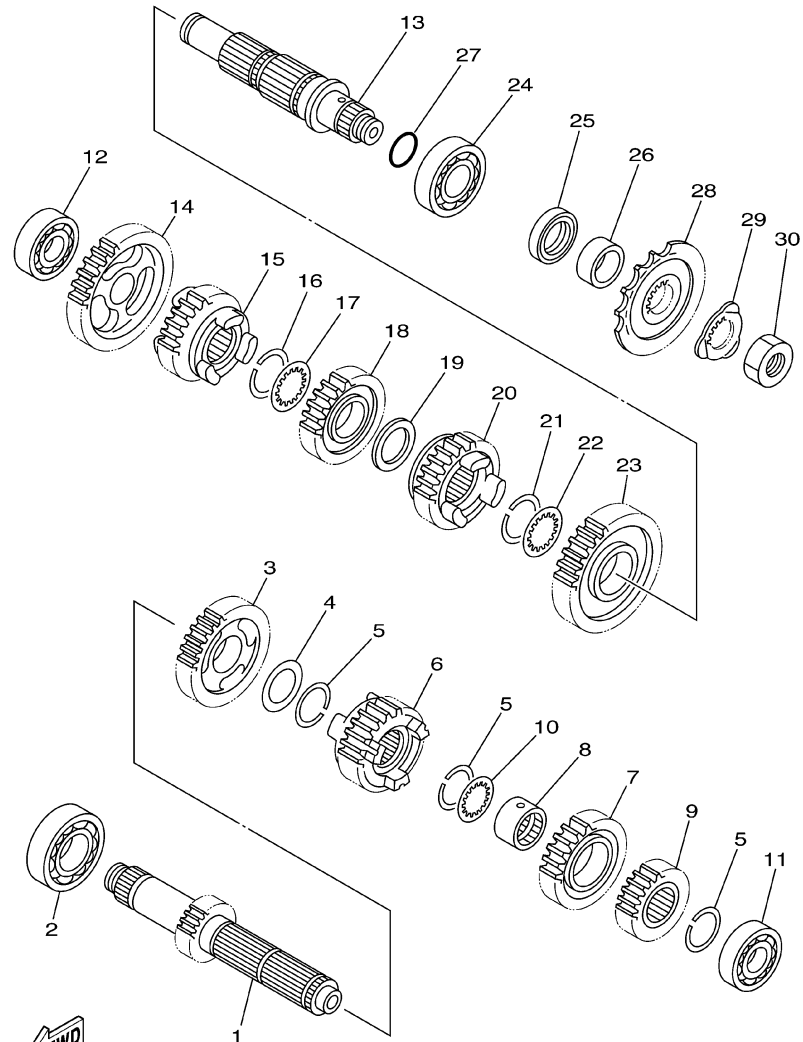

5CU1100-9130

REF. NO.	PART NO.	DESCRIPTION	5MW1	5MW2	5MW3	5MW4	REMARKS
28	9383E-14215	SPROCKET, DRIVE (14T)	1	1	1	1	STD
	9383E-13144	SPROCKET,DRIVE (13T) (2141746130)	1	1	1	1	AP
29	90215-21256	WASHER, LOCK	1	1	1	1	
30	90179-20255	NUT	1	1	1	1	

FIG. 14 SHIFT CAM. FORK

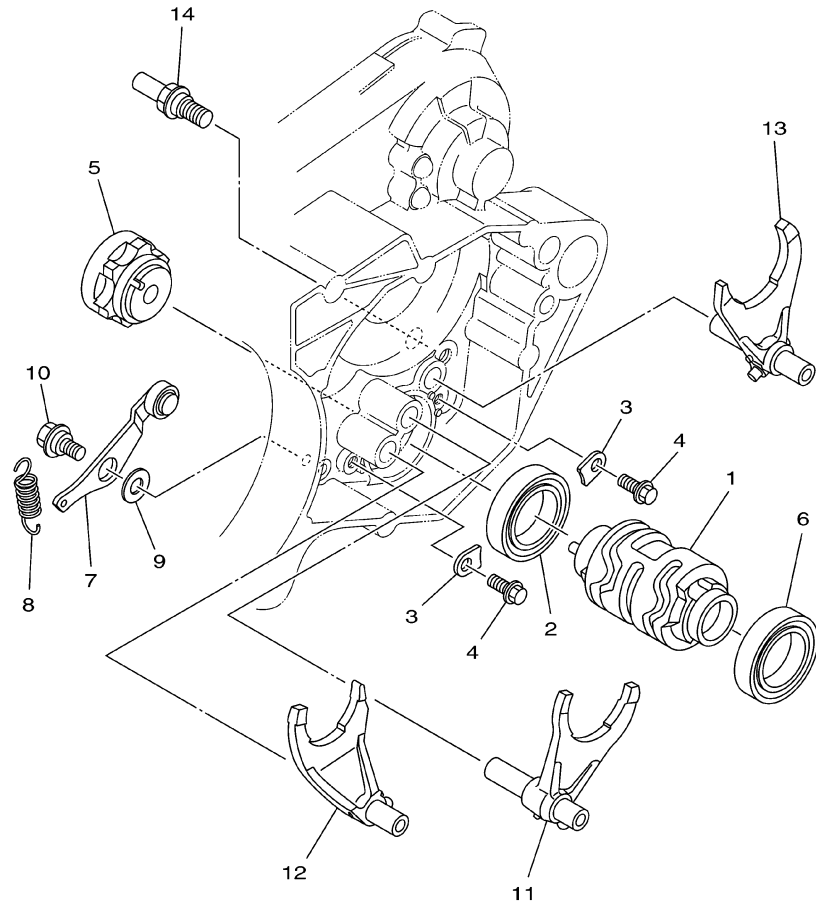

REF. NO.	PART NO.	DESCRIPTION	5MW1	5MW2	5MW3	5MW4	REMARKS
1	5MW-18541-00	CAM, SHIFT	1	1	1	1	
2	93306-90504	BEARING	1	1	1	1	
3	5DH-18562-00	PLATE, STOPPER 2	2	2	2	2	
4	90105-06553	BOLT, FLANGE	2	2	2	2	
5	4EW-18185-00	SEGMENT	1	1	1	1	
6	93306-90501	BEARING	1	1	1	1	
7	5CU-18140-01	STOPPER LEVER ASSY	1	1	1	1	
8	90507-14064	SPRING, TENSION	1	1	1	1	
9	90201-06013	WASHER, PLATE	1	1	1	1	
10	90109-063F8	BOLT	1	1	1	1	
11	5BE-18501-00	FORK, SHIFT 1	1	1	1	1	
12	5BE-18502-10	FORK, SHIFT 2	1	1	1	1	
13	5CU-18503-00	FORK, SHIFT 3	1	1	1	1	
14	4BR-18127-00	STOPPER, SCREW	1	1	1	1	



5MW1100-1140

FIG. 15 SHIFT SHAFT

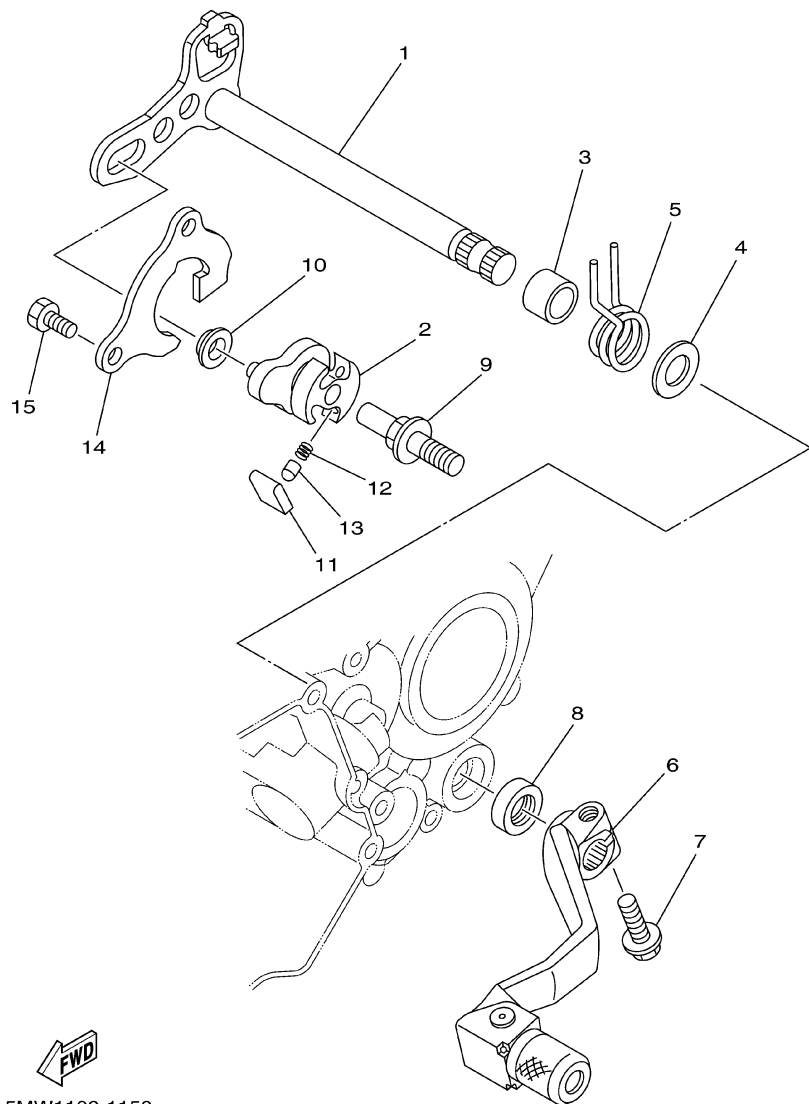

REF. NO.	PART NO.	DESCRIPTION	5MW1	5MW2	5MW3	5MW4	REMARKS
1	5CU-18101-00	SHIFT SHAFT ASSY	1	1	1	1	
2	5MW-18122-00	LEVER, SHIFT 2	1	1	1	1	
3	90387-124F4	COLLAR	1	1	1	1	
4	90201-12575	WASHER, PLATE	1	1	1	1	
5	90508-291A8	SPRING, TORSION	1	1	1	1	
6	5CU-18110-00	SHIFT PEDAL ASSY	1	1	1	1	
7	95027-06020	BOLT, FLANGE	1	1	1	1	
8	93102-12224	OIL SEAL	1	1	1	1	
9	3XJ-18173-00	PIN, SHIFT	1	1	1	1	
10	3XJ-18178-00	ROLLER, SHIFT LEVER	1	1	1	1	
11	3XJ-18182-00	PAWL, SHIFTER	2	2	2	2	
12	90501-052G5	SPRING, COMPRESSION	2	2	2	2	
13	3XJ-18184-00	PIN, PAWL	2	2	2	2	
14	5CU-18172-00	GUIDE, SHIFT	1	1	1	1	
15	90101-06664	BOLT	2	2	2	2	

FIG. 16 FRAME

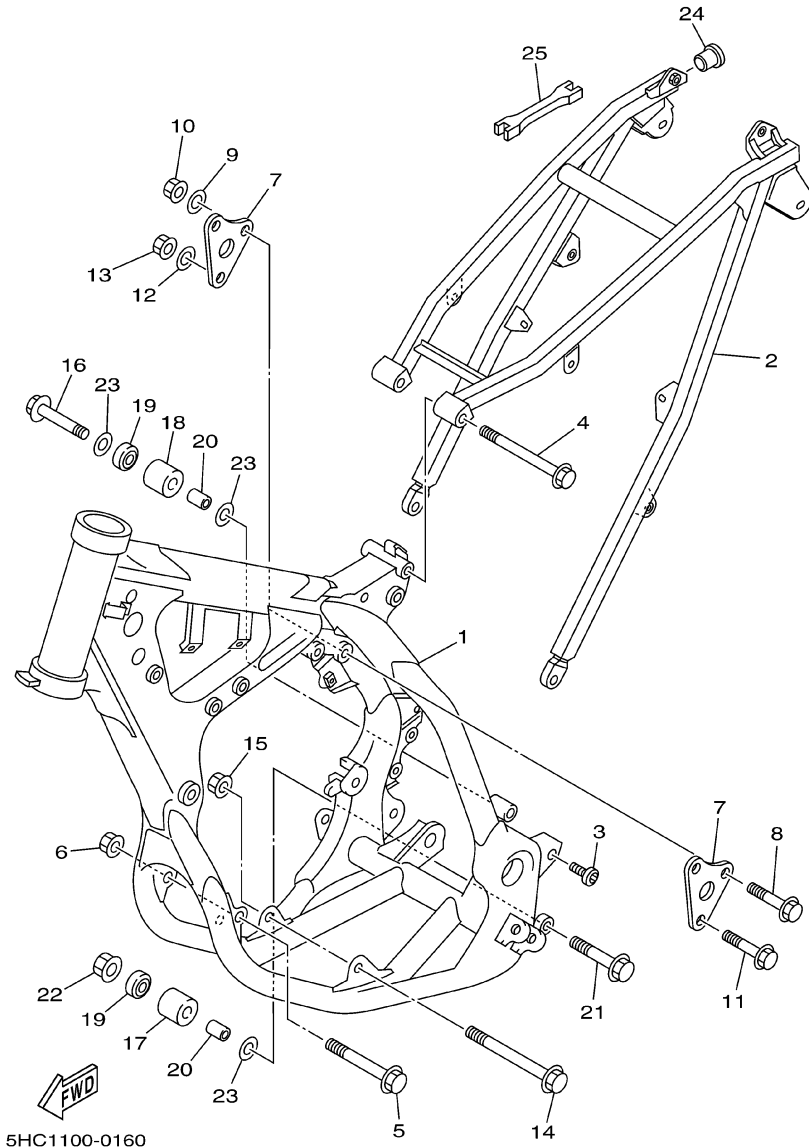

REF. NO.	PART NO.	DESCRIPTION	5MW1	5MW2	5MW3	5MW4	REMARKS
1	5MW-21101-00-P0	FRONT FRAME COMP.	1	1	1	1	DPBMC
2	5HC-21190-00-P0	REAR FRAME COMP.	1	1	1	1	DPBMC
3	90110-08096	BOLT, HEXAGON SOCKET HEAD	2	2	2	2	
4	90105-08099	BOLT, FLANGE	1	1	1	1	
5	95817-10110	BOLT, FLANGE	1	1	1	1	
6	95607-10200	NUT, SELF-LOCKING	1	1	1	1	
7	5CU-21425-00	BRACKET, REAR UPPER 1	2	2	2	2	
8	95817-08050	BOLT, FLANGE	2	2	2	2	
9	90201-08730	WASHER, PLATE	2	2	2	2	
10	90185-08169	NUT, SELF-LOCKING	2	2	2	2	
11	95817-10050	BOLT, FLANGE	1	1	1	1	
12	92907-10200	WASHER, PLAIN	1	1	1	1	
13	95607-10200	NUT, SELF-LOCKING	1	1	1	1	
14	90105-10119	BOLT, FLANGE	1	1	1	1	
15	95607-10200	NUT, SELF-LOCKING	1	1	1	1	
16	95027-08040	BOLT, FLANGE	1	1	1	1	
17	3JD-22178-10	TENSIONER	1	1	1	1	
18	4EW-22178-00	TENSIONER	1	1	1	1	
19	93300-60804	BEARING	2	2	2	2	
20	90387-086N4	COLLAR	2	2	2	2	
21	95027-08065	BOLT, FLANGE	1	1	1	1	
22	95707-08500	NUT, FLANGE	1	1	1	1	
23	90201-086P8	WASHER, PLATE	3	3	3	3	
24	90338-16148	PLUG	2	2	2	2	
25	5ET-28166-00	WRENCH, HEXAGON	1	1	1	1	

FIG. 17 FENDER

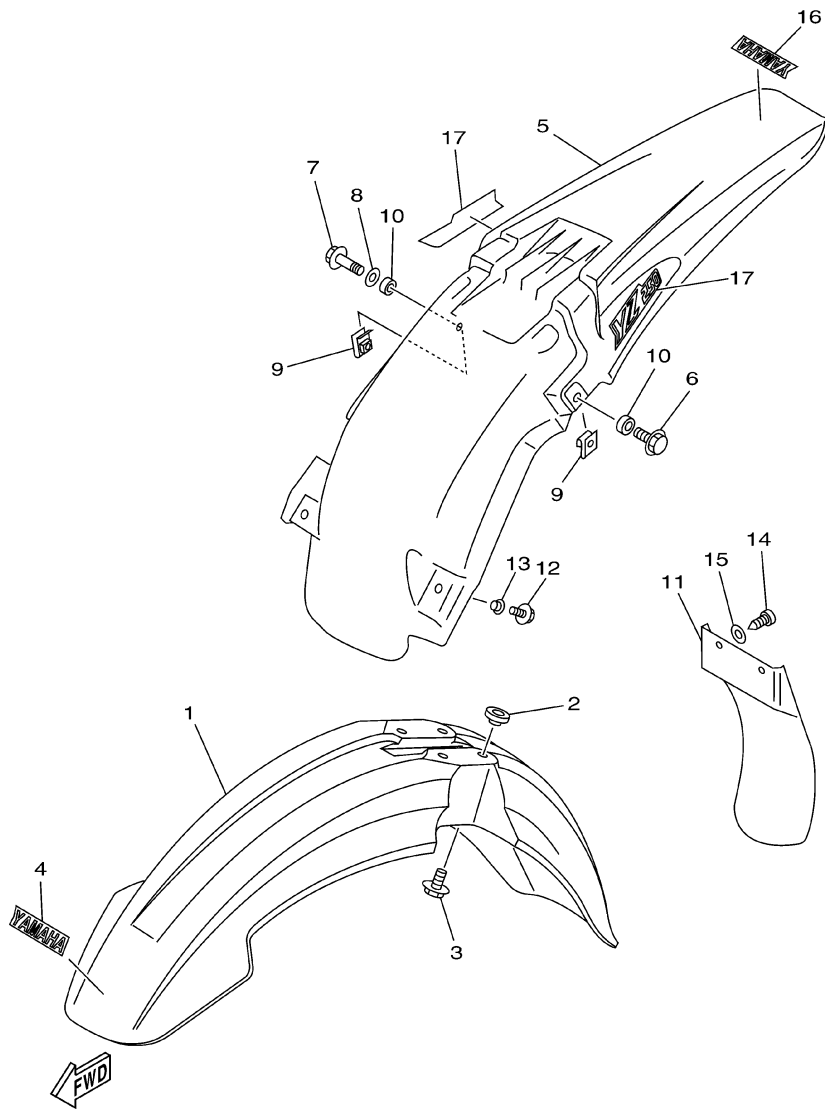

REF. NO.	PART NO.	DESCRIPTION	5MW1	5MW2	5MW3	5MW4	REMARKS
1	5HD-21511-00	FENDER, FRONT	1	1	1	1	
2	3JD-21748-00	COLLAR	4	4	4	4	
3	90119-06096	BOLT, WITH WASHER	4	4	4	4	
4	4ES-2153E-01	EMBLEM, YAMAHA	1	1	1	1	
5	5BE-21611-10	FENDER, REAR	1	1	1	1	
6	90119-06192	BOLT, WITH WASHER	1	1	1	1	
7	95027-06030	BOLT, FLANGE	1	1	1	1	
8	90201-06071	WASHER, PLATE	1	1	1	1	
9	90183-06023	NUT, SPRING	2	2	2	2	
10	90387-0701A	COLLAR	2	2	2	2	
11	5BE-21642-00	GUARD, FLAP	1	1	1	1	
12	90119-06225	BOLT, WITH WASHER	2	2	2	2	
13	90387-06009	COLLAR	2	2	2	2	
14	97707-60016	SCREW, TAPPING	2	2	2	2	
15	90201-06557	WASHER, PLATE	2	2	2	2	
16	4ES-2153E-01	EMBLEM, YAMAHA	1	1	1	1	
17	5MW-21781-00	EMBLEM 1	2	2	2	2	

FIG. 18 SIDE COVER

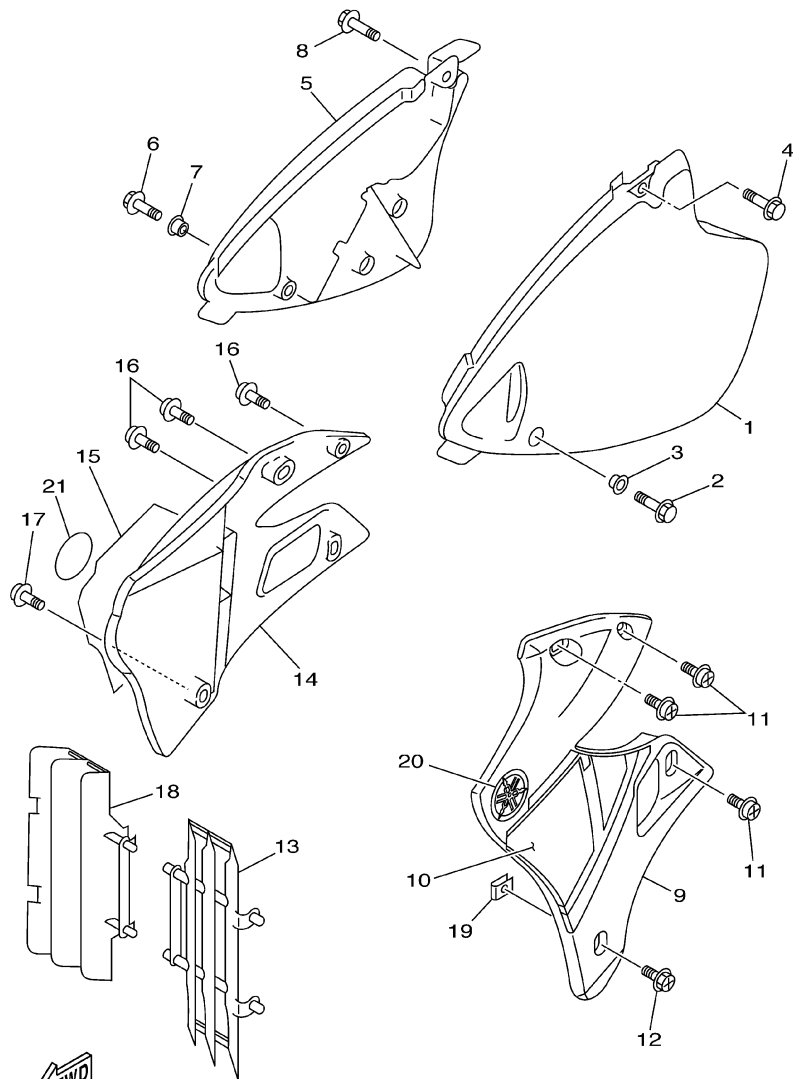

5MV1100-1180

REF. NO.	PART NO.	DESCRIPTION	5MW1	5MW2	5MW3	5MW4	REMARKS
1	4SS-21711-00	COVER, SIDE 1	1	1	1	1	
2	95827-06016	BOLT, FLANGE	1	1	1	1	
3	90387-06009	COLLAR	1	1	1	1	
4	95827-06016	BOLT, FLANGE	1	1	1	1	
5	4SS-21721-00	COVER, SIDE 2	1	1	1	1	
6	95827-06016	BOLT, FLANGE	1	1	1	1	
7	90387-06009	COLLAR	1	1	1	1	
8	95827-06016	BOLT, FLANGE	1	1	1	1	
9	5ET-21730-10	SIDE COVER ASSY 3	1	1	1	1	
10	5MV-2173E-00	GRAPHIC 1	1	1	1	1	
11	90159-06182	SCREW, WITH WASHER	3	3	3	3	
12	90159-06078	SCREW, WITH WASHER	1	1	1	1	
13	4EW-2172A-00	PANEL 1	1	1	1	1	
14	5ET-21740-10	SIDE COVER ASSY 4	1	1	1	1	
15	5MV-2173F-00	GRAPHIC 2	1	1	1	1	
16	90159-06182	SCREW, WITH WASHER	3	3	3	3	
17	90159-06078	SCREW, WITH WASHER	1	1	1	1	
18	4EW-2172A-00	PANEL 1	1	1	1	1	
19	90183-06069	NUT, SPRING	2	2	2	2	
20	5MV-2175C-00	TUNING FORK MARK	1	1	1	1	
21	5MV-2175C-00	TUNING FORK MARK	1	1	1	1	

FIG. 19 REAR ARM

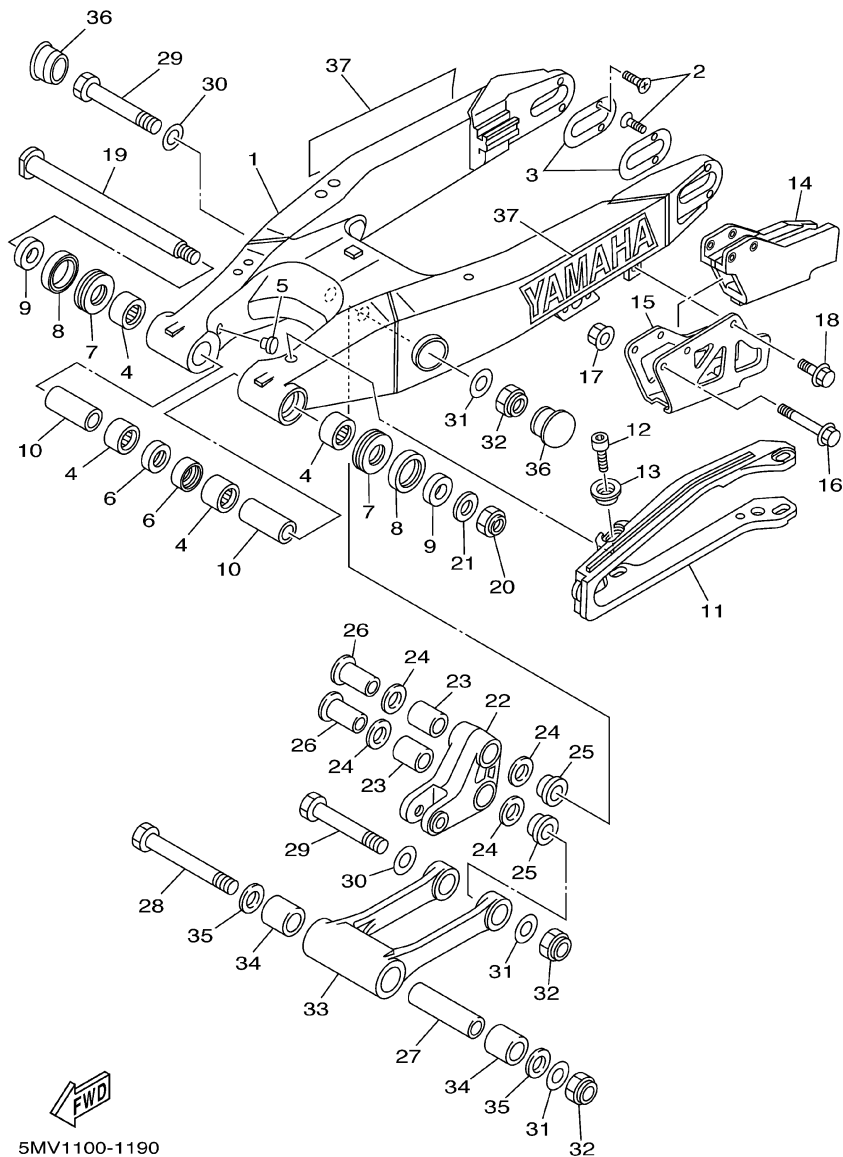

5MV1100-1190

REF. NO.	PART NO.	DESCRIPTION	5MW1	5MW2	5MW3	5MW4	REMARKS
1	5MV-22110-00	REAR ARM COMP.	1	1	1	1	
2	90151-04048	SCREW, COUNTERSUNK	4	4	4	4	
3	5ET-22355-00	PATCH	2	2	2	2	
4	93317-22262	BEARING	4	4	4	4	
5	90338-16148	PLUG	2	2	2	2	
6	93106-22019	OIL SEAL (DC 22-28-8)	2	2	2	2	
7	93342-22217	BEARING	2	2	2	2	
8	93109-28043	OIL SEAL	2	2	2	2	
9	90387-1714R	COLLAR	2	2	2	2	
10	90387-1714S	COLLAR	2	2	2	2	
11	5MV-22151-00	SEAL, GUARD	1	1	1	1	
12	91317-05008	BOLT	4	4	4	4	
13	5JG-22156-00	WASHER, PLATE	4	4	4	4	
14	4XM-22199-00	SUPPORT, CHAIN	1	1	1	1	
15	4XM-22128-00	COVER, THRUST 1	1	1	1	1	
16	95027-06050	BOLT, FLANGE	2	2	2	2	
17	90179-06568	NUT	2	2	2	2	
18	95027-06010	BOLT, FLANGE	1	1	1	1	
19	5DH-22141-00	SHAFT, PIVOT	1	1	1	1	
20	90185-16127	NUT, SELF-LOCKING	1	1	1	1	
21	90201-164H4	WASHER, PLATE	1	1	1	1	
22	5ET-2217A-00	ARM, RELAY	1	1	1	1	
23	93315-32056	BEARING	2	2	2	2	
24	93109-20076	OIL SEAL	4	4	4	4	
25	90387-16005	COLLAR	2	2	2	2	
26	90387-16007	COLLAR	2	2	2	2	
27	90387-167Y9	COLLAR	1	1	1	1	

FIG. 19 REAR ARM

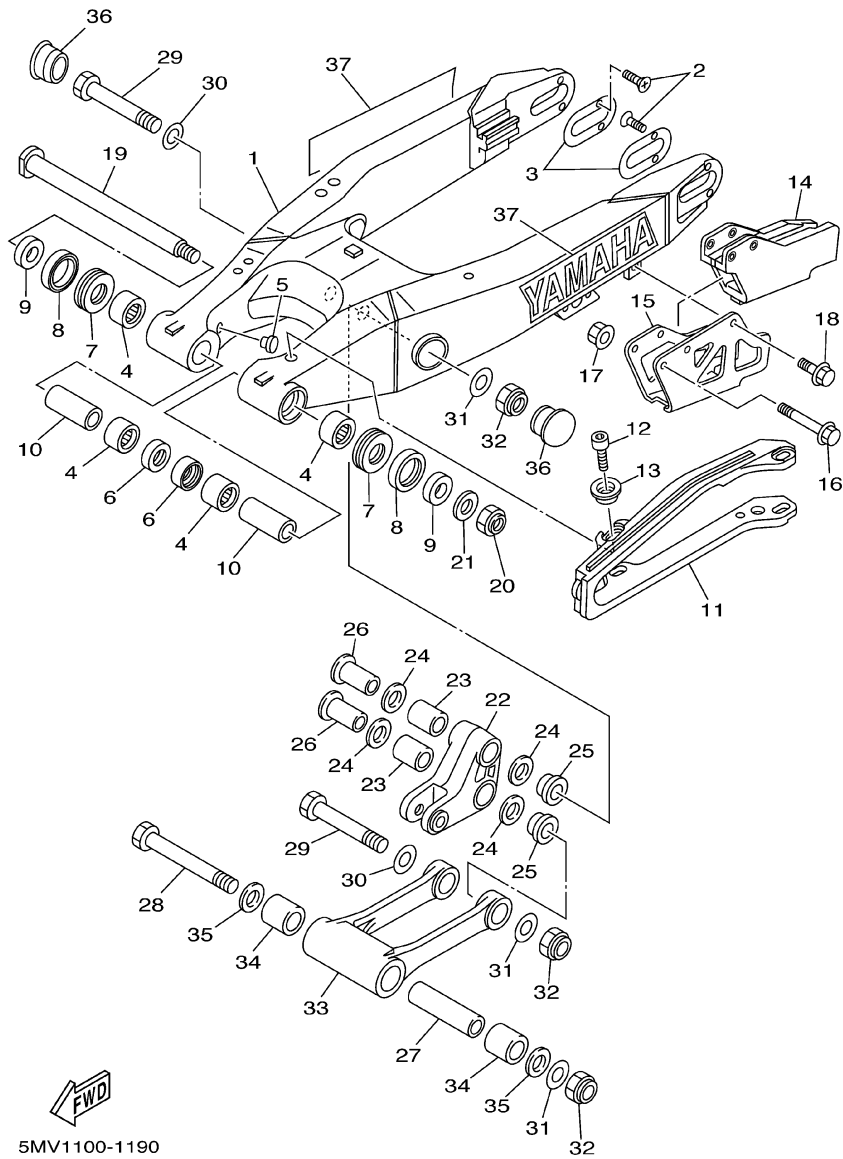

REF. NO.	PART NO.	DESCRIPTION	5MW1	5MW2	5MW3	5MW4	REMARKS
28	90109-147F2	BOLT	1	1	1	1	
29	90109-142F4	BOLT	2	2	2	2	
30	90201-164H4	WASHER, PLATE	2	2	2	2	
31	90201-14740	WASHER, PLATE	3	3	3	3	
32	90185-14112	NUT, SELF-LOCKING	3	3	3	3	
33	5DH-2217F-01	ROD, CONNECTING 1	1	1	1	1	
34	93315-32056	BEARING	2	2	2	2	
35	93109-20076	OIL SEAL	2	2	2	2	
36	5HD-2135F-00	COVER	2	2	2	2	
37	99244-00200	EMBLEM, YAMAHA	2	2	2	2	

FIG. 20 REAR SUSPENSION

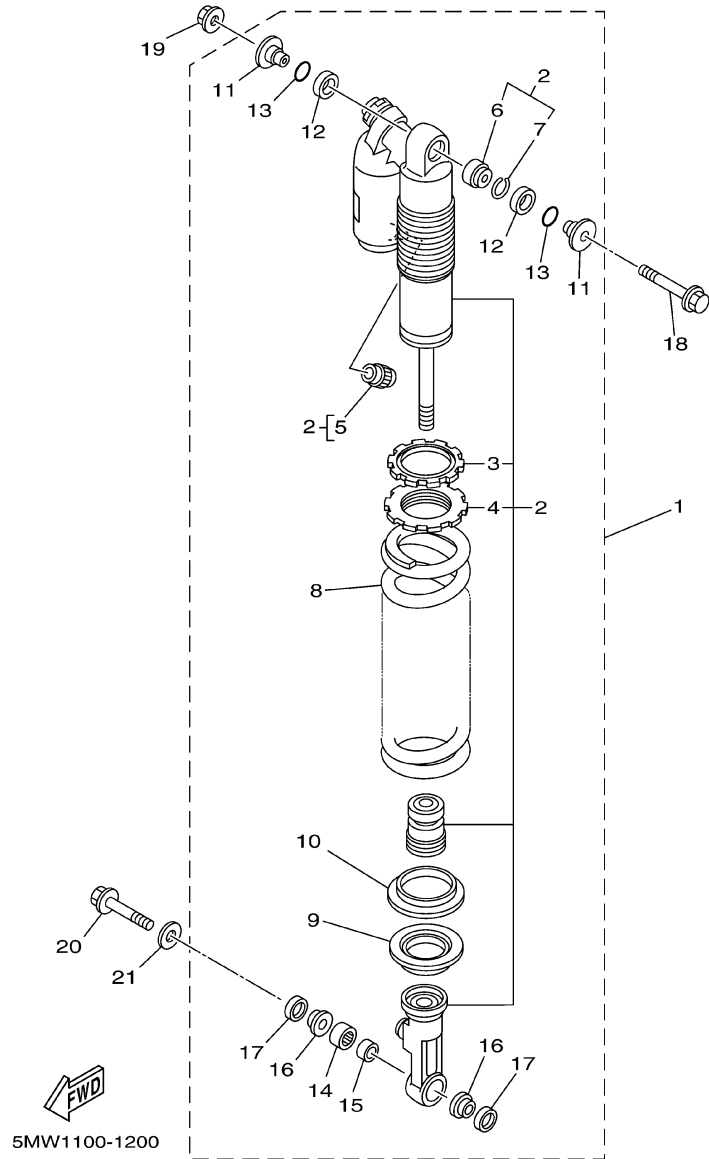

REF. NO.	PART NO.	DESCRIPTION	5MW1	5MW2	5MW3	5MW4	REMARKS
1	5MW-22210-00	SHOCK ABSORBER ASSY, REAR	1				UR
	5MW-22210-30	SHOCK ABSORBER ASSY, REAR	1				UR FOR CAN
	5MW-22210-40	SHOCK ABSORBER ASSY, REAR	1			1	UR FOR ZAF
	5MW-22210-10	SHOCK ABSORBER ASSY, REAR		1			
	5MW-22210-20	SHOCK ABSORBER ASSY, REAR			1		
2	5MW-22201-00	.DAMPER SUB ASSY	1				UR
	5MW-22201-30	.DAMPER SUB ASSY	1				UR FOR CAN
	5MW-22201-40	.DAMPER SUB ASSY	1			1	UR FOR ZAF
	5MW-22201-10	.DAMPER SUB ASSY		1			
	5MW-22201-20	.DAMPER SUB ASSY			1		
3	3SP-22234-00	..GUIDE, SPRING 3	1	1	1	1	
4	3SP-22213-00	..SEAT, SPRING UPPER	1	1	1	1	
5	509-23184-L0	..CAP, AIR VALVE	1	1	1	1	
6	4JX-22226-00	..BUSH, SHOCK ABSORBER LOWER	1	1	1	1	
7	5DH-23183-00	..CIRCLIP	1	1	1	1	
8	5DH-22212-20	..SPRING (K=4.8)	1			1	
	5ET-22212-10	..SPRING (K=APPROX.5.0)		1	1		
9	5DH-22214-00	..GUIDE, SPRING 1	1	1	1	1	
10	5MV-22224-00	..GUIDE, SPRING 2	1	1	1	1	
11	5DH-22253-00	..COLLAR, DISTANCE	2	2	2	2	
12	3JE-22475-00	..SEAL, DUST	2	2	2	2	
13	4EW-22474-00	..SEAL, RING	2	2	2	2	
14	5MV-22176-00	..BEARING	1	1	1	1	
15	5MV-22184-00	..BUSH	1	1	1	1	
16	5MV-22253-00	..COLLAR, DISTANCE	2	2	2	2	
17	5MV-22475-00	..SEAL, DUST	2	2	2	2	
18	90105-10323	BOLT, FLANGE	1	1	1	1	

FIG. 21 STEERING

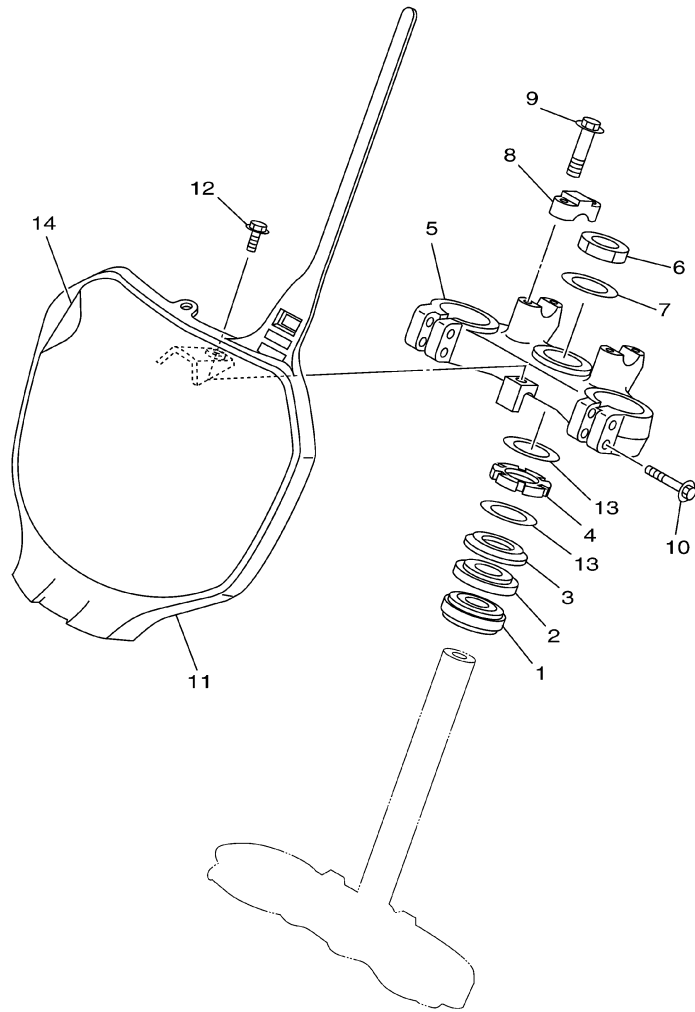

REF. NO.	PART NO.	DESCRIPTION	5MW1	5MW2	5MW3	5MW4	REMARKS
1	93332-00081	BEARING	1	1	1	1	
2	93332-00068	BEARING	1	1	1	1	
3	4EW-23416-00	COVER, BALL RACE 2	1	1	1	1	
4	90179-28650	NUT	1	1	1	1	
5	5HC-23435-00	CROWN, HANDLE		1	1	1	
	5HC-23435-11	CROWN, HANDLE	1				
6	90170-24373	NUT	1	1	1	1	
7	90201-247L2	WASHER, PLATE	1	1	1	1	
8	3SP-23441-00	HOLDER, HANDLE UPPER	2	2	2	2	
9	95027-08035	BOLT, FLANGE	4	4	4	4	
10	95027-08040	BOLT, FLANGE	4	4	4	4	
11	5HD-23485-00	PLATE, NUMBER	1	1	1	1	
12	95027-06014	BOLT, FLANGE	1	1	1	1	
13	90201-286K9	WASHER, PLATE	2	2	2	2	
14	5HD-2339E-00	GRAPHIC 1	1	1	1	1	

 5HD1100-0210

FIG. 22 FRONT FORK

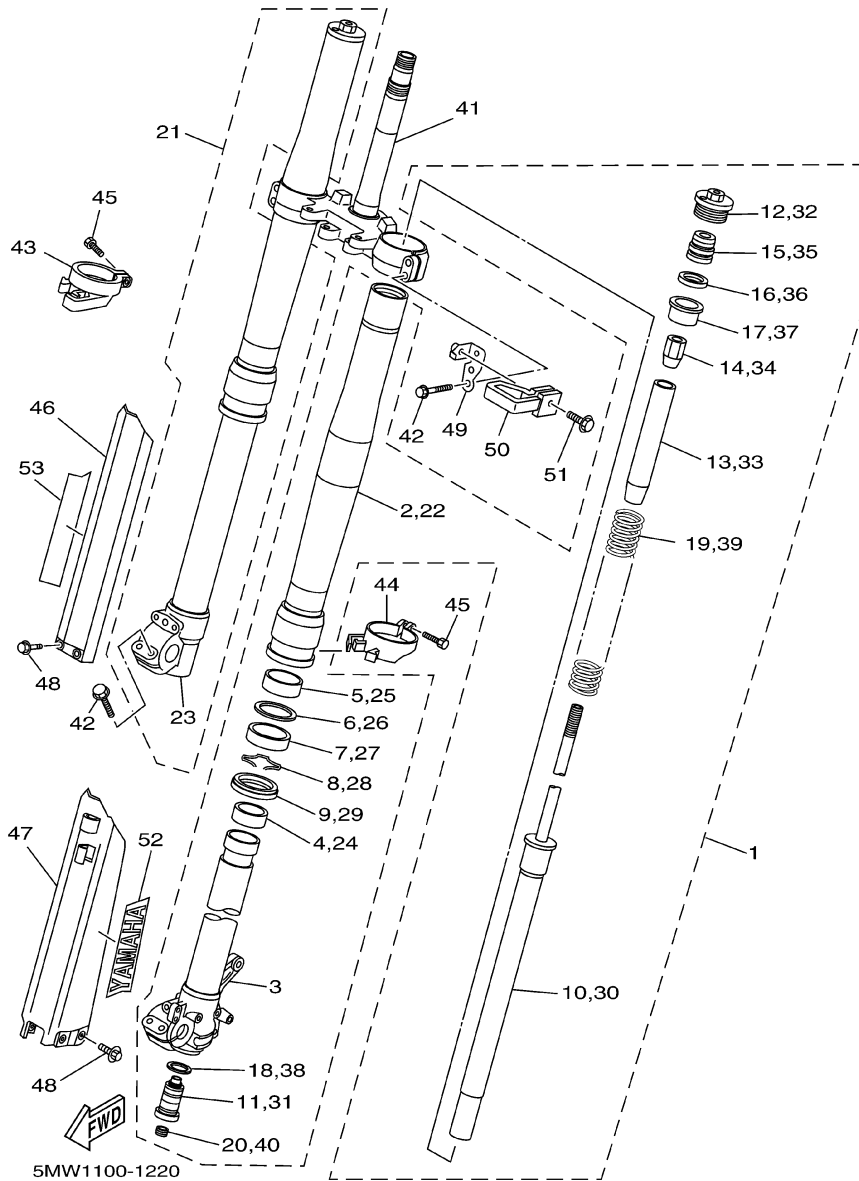

REF. NO.	PART NO.	DESCRIPTION	5MW1	5MW2	5MW3	5MW4	REMARKS
1	5MW-23102-00	FRONT FORK ASSY (L.H)	1			1	
	5MW-23102-10	FRONT FORK ASSY (L.H)		1			
	5MW-23102-20	FRONT FORK ASSY (L.H)			1		
2	5HD-23136-L0	.TUBE, OUTER (RIGHT)	1	1	1	1	
3	5DH-23120-L0	.INNER TUBE COMP.2	1	1	1	1	
4	5ET-23171-L0	.PISTON, FRONT FORK	1	1	1	1	
5	5ET-23125-L0	.METAL, SLIDE 1	1	1	1	1	
6	4SS-23146-L0	.WASHER, OIL SEAL	1	1	1	1	
7	5ET-23145-L0	.OIL SEAL	1	1	1	1	
8	4SS-23153-L0	.RING, SNAP	1	1	1	1	
9	5HD-23144-L0	.SEAL, DUST	1	1	1	1	
10	5MV-23170-L0	.CYLINDER COMP., FRONT FORK	1	1	1	1	
11	5MV-2316A-L0	.VALVE COMP.	1			1	
	5MW-2316A-M0	.VALVE COMP.		1			
	5MV-2316A-M0	.VALVE COMP.			1		
12	5MV-23111-L0	.BOLT, CAP	1	1	1	1	
13	5DH-23142-L0	.SEAT, SPRING UPPER	1	1	1	1	
14	5HD-23393-L0	.NUT, SPECIAL	1	1	1	1	
15	5MV-23195-L0	.RUBBER	1			1	
	5DH-23195-L0	.RUBBER		1	1		
16	5DH-23149-L0	.WASHER, SPRING UPPER	1	1	1	1	
17	5DH-23118-L0	.SPACER	1	1	1	1	
18	4SS-23158-L0	.GASKET	1	1	1	1	
19	4XL-23141-L0	.SPRING, FRONT FORK (K=0.43)	1			1	
	5CU-23141-L0	.SPRING (K=APPROX.0.43)		1			
	4SR-23141-L0	.SPRING, FRONT FORK (K=0.42)			1		
20	3JD-2312G-L0	.PLUG	1	1	1	1	

FIG. 22 FRONT FORK

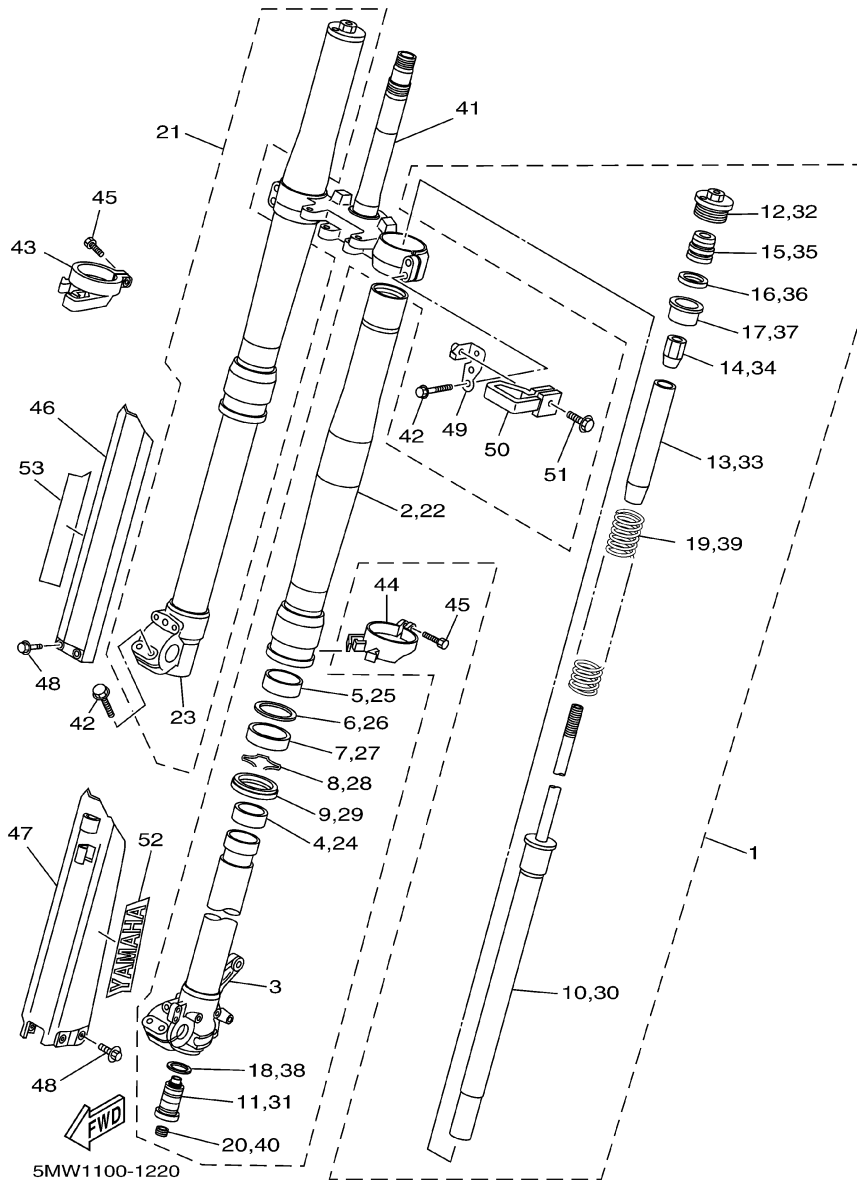

REF. NO.	PART NO.	DESCRIPTION	5MW1	5MW2	5MW3	5MW4	REMARKS
21	5MW-23103-00	FRONT FORK ASSY (R.H)	1			1	
	5MW-23103-10	FRONT FORK ASSY (R.H)		1			
	5MW-23103-20	FRONT FORK ASSY (R.H)			1		
22	5HD-23136-L0	.TUBE, OUTER (RIGHT)	1	1	1	1	
23	5BF-23110-L0	.INNER TUBE COMP.1	1	1	1	1	
24	5ET-23171-L0	.PISTON, FRONT FORK	1	1	1	1	
25	5ET-23125-L0	.METAL, SLIDE 1	1	1	1	1	
26	4SS-23146-L0	.WASHER, OIL SEAL	1	1	1	1	
27	5ET-23145-L0	.OIL SEAL	1	1	1	1	
28	4SS-23153-L0	.RING, SNAP	1	1	1	1	
29	5HD-23144-L0	.SEAL, DUST	1	1	1	1	
30	5MV-23170-L0	.CYLINDER COMP., FRONT FORK	1	1	1	1	
31	5MV-2316A-L0	.VALVE COMP.	1			1	
	5MW-2316A-M0	.VALVE COMP.		1			
	5MV-2316A-M0	.VALVE COMP.			1		
32	5MV-23111-L0	.BOLT, CAP	1	1	1	1	
33	5DH-23142-L0	.SEAT, SPRING UPPER	1	1	1	1	
34	5HD-23393-L0	.NUT, SPECIAL	1	1	1	1	
35	5MV-23195-L0	.RUBBER	1			1	
	5DH-23195-L0	.RUBBER		1	1		
36	5DH-23149-L0	.WASHER, SPRING UPPER	1	1	1	1	
37	5DH-23118-L0	.SPACER	1	1	1	1	
38	4SS-23158-L0	.GASKET	1	1	1	1	
39	4XL-23141-L0	.SPRING, FRONT FORK (K=0.43)	1			1	
	5CU-23141-L0	.SPRING (K=APPROX.0.43)		1			
	4SR-23141-L0	.SPRING, FRONT FORK (K=0.42)			1		
40	3JD-2312G-L0	.PLUG	1	1	1	1	

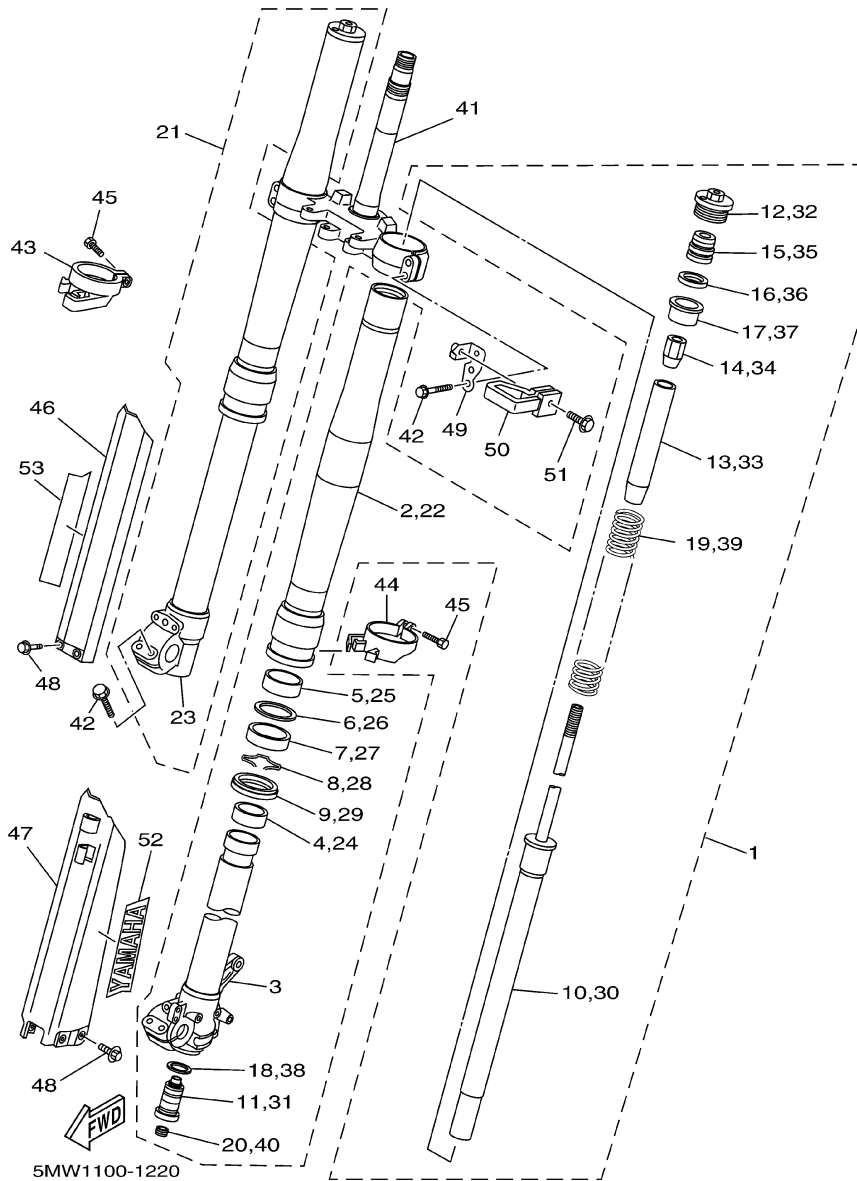
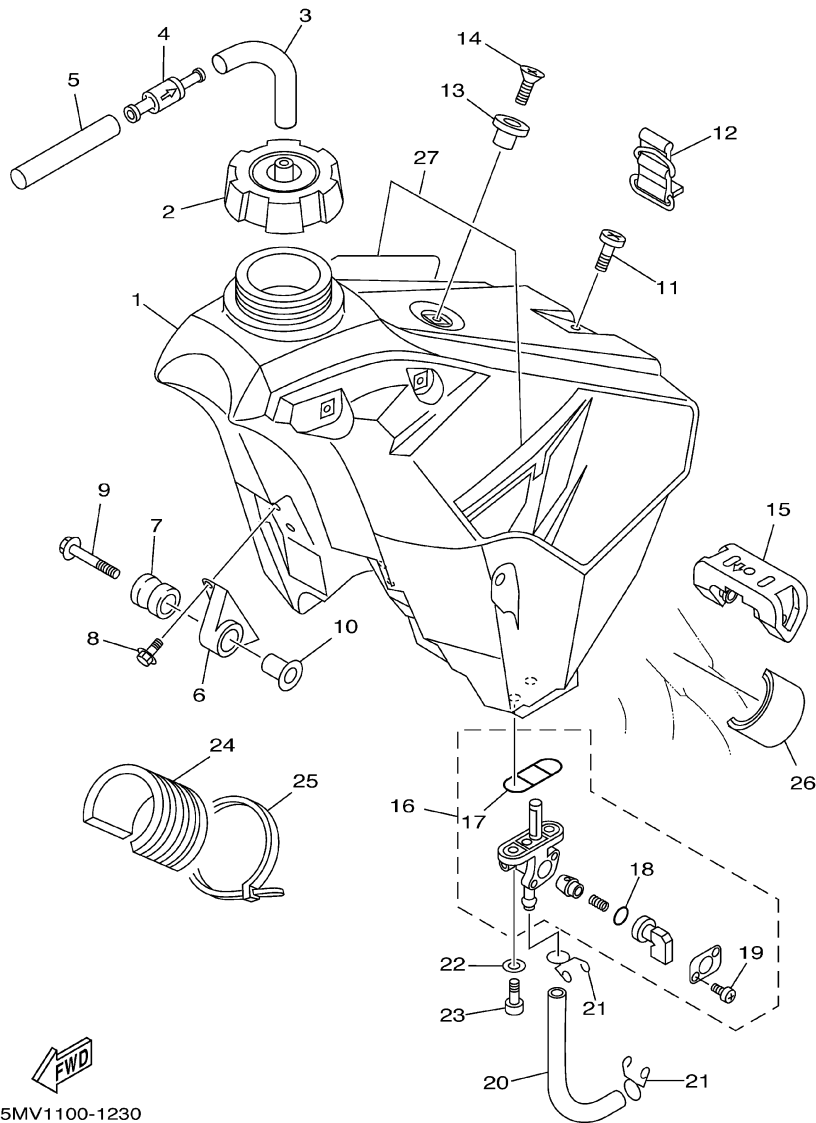

FIG. 22 FRONT FORK

REF. NO.	PART NO.	DESCRIPTION	5MW1	5MW2	5MW3	5MW4	REMARKS
41	5HC-23340-M0	UNDER BRACKET COMP.	1	1	1	1	
42	5MV-23346-L0	BOLT 1	8	8	8	8	
43	4SS-2314G-L0	PROTECTOR GUIDE COMP., 2	1	1	1	1	
44	5DH-2314F-L0	PROTECTOR GUIDE COMP., 1	1	1	1	1	
45	4SS-23346-L0	BOLT 1	2	2	2	2	
46	5DH-2314J-00	PROTECTOR COMP., 2	1	1	1	1	
47	5DH-2314H-00	PROTECTOR COMP., 1	1	1	1	1	
48	3SP-23356-L0	BOLT 2	6	6	6	6	
49	5HC-2331E-00	GUIDE, CABLE	1	1	1	1	
50	4DA-23389-00	GUIDE, CABLE	1	1	1	1	
51	90119-05071	BOLT, WITH WASHER	1	1	1	1	
52	4XL-2153A-10	EMBLEM, YAMAHA	1	1	1	1	
53	4XL-2153A-10	EMBLEM, YAMAHA	1	1	1	1	

FIG. 23 FUEL TANK



5MV1100-1230

REF. NO.	PART NO.	DESCRIPTION	5MW1	5MW2	5MW3	5MW4	REMARKS
1	5MW-24110-00	FUEL TANK COMP.	1	1	1	1	
2	5MV-24610-00	CAP ASSY	1	1	1	1	
3	90445-09220	HOSE	1	1	1	1	
4	3XJ-24380-00	PIPE JOINT ASSY	1	1	1	1	
5	90445-09104	HOSE	1	1	1	1	
6	24X-24144-00	HOLDER, DAMPER	2	2	2	2	
7	90480-18549	GROMMET	2	2	2	2	
8	95027-06016	BOLT, FLANGE	4	4	4	4	
9	90119-06214	BOLT, WITH WASHER	2	2	2	2	
10	3JD-24186-00	WASHER, SPECIAL	2	2	2	2	
11	98907-06020	SCREW, BIND	1	1	1	1	
12	3SP-24173-00	BAND, TANK FITTING 1	1	1	1	1	
13	4EW-2412F-00	BRACKET, SEAT	1	1	1	1	
14	98707-06025	SCREW, FLAT HEAD	1	1	1	1	
15	4SS-24181-00	DAMPER, LOCATING 1	1	1	1	1	
16	3JD-24500-01	FUEL COCK ASSY 1	1	1	1	1	
17	4X8-24512-00	.O-RING	1	1	1	1	
18	3AJ-24534-00	.SEAL, COCK	1	1	1	1	
19	97801-03008	.SCREW, PAN HEAD	2	2	2	2	
20	90445-116G8	HOSE (L135)	1	1	1	1	
21	90467-10008	CLIP	2	2	2	2	
22	90202-05193	WASHER, PLATE	2	2	2	2	
23	90149-06011	SCREW	2	2	2	2	
24	4SS-24182-00	DAMPER, LOCATING 2	1	1	1	1	
25	90465-13275	CLAMP	1	1	1	1	
26	3V6-22358-00	SEAL 1	2	2	2	2	
27	5MV-24240-00	GRAPHIC SET	1	1	1	1	

FIG. 24 SEAT

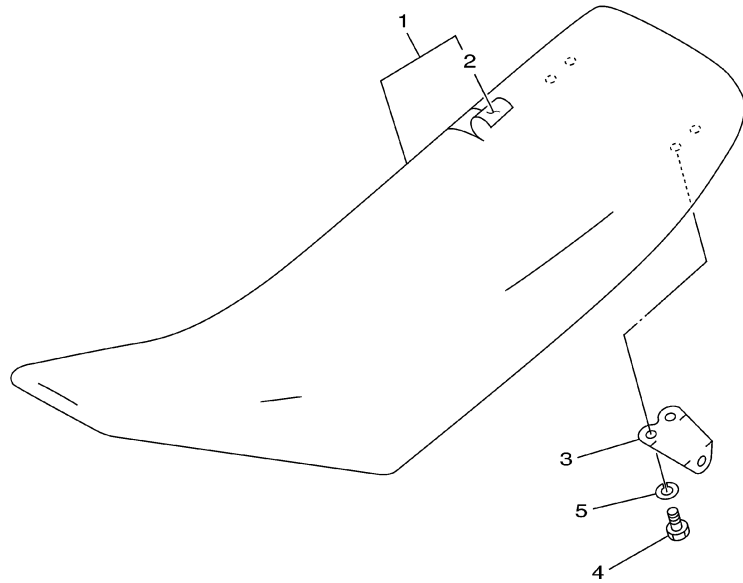

REF. NO.	PART NO.	DESCRIPTION	5MW1	5MW2	5MW3	5MW4	REMARKS
1	5MV-24770-00	SEMI-DOUBLE SEAT ASSY	1	1	1	1	
2	5MV-24731-00	.COVER, SEAT	1	1	1	1	
3	4SS-24728-00	.BRACKET, SEAT	2	2	2	2	
4	97007-06012	.BOLT	4	4	4	4	
5	92907-06100	.WASHER, SPRING	4	4	4	4	

 4SS1100-6240

FIG. 25 FRONT WHEEL

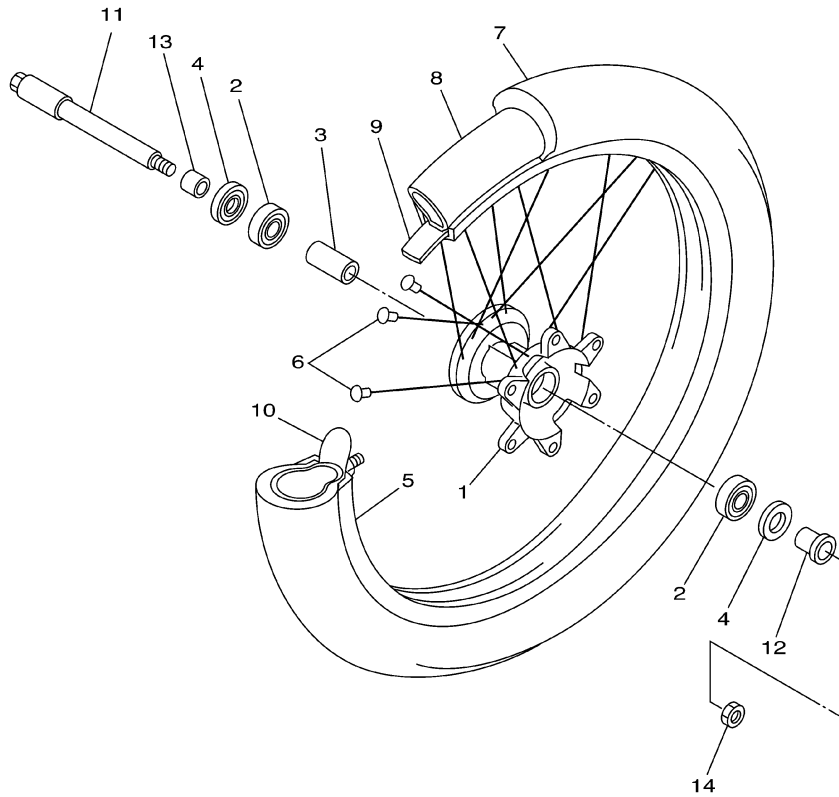

REF. NO.	PART NO.	DESCRIPTION	5MW1	5MW2	5MW3	5MW4	REMARKS
1	4SS-25111-01	HUB, FRONT	1	1	1	1	
2	93306-90403	BEARING	2	2	2	2	
3	5DH-25117-00	SPACER, BEARING	1	1	1	1	
4	93102-26468	OIL SEAL	2	2	2	2	
5	94416-21613	RIM (1.60-21)	1	1	1	1	
6	4DA-25104-00	SPOKE SET, FRONT	1	1	1	1	
7	94108-2112Y	TIRE (80/100-21 51M D755F)	1	1			UR DUNLOP FOR CAN
	94108-21011	TIRE (80/100-21 51M D739FA)	1			1	UR DUNLOP
	94108-2110Y	TIRE (80/100-21 51M M77)			1		BRIDGESTONE
8	94227-21101	TUBE (80/100-21 TR4 BTL)	1	1		1	DUNLOP
	94209-21229	TUBE (80/100C-21 TR4)			1		BRIDGESTONE
9	94309-21161	BAND, RIM (70-80/100-21)	1	1		1	DUNLOP
	94330-21084	BAND, RIM (3.00-21)			1		BRIDGESTONE
10	2J5-25394-01	SPACER, BEAD	1	1	1	1	
11	5BE-25181-00	AXLE, WHEEL	1	1	1	1	
12	5DH-25183-00	COLLAR, WHEEL	1	1	1	1	
13	5BE-25186-00	COLLAR, WHEEL	1	1	1	1	
14	90179-16672	NUT	1	1	1	1	



4SS1100-6250

FIG. 26 FRONT BRAKE CALIPER

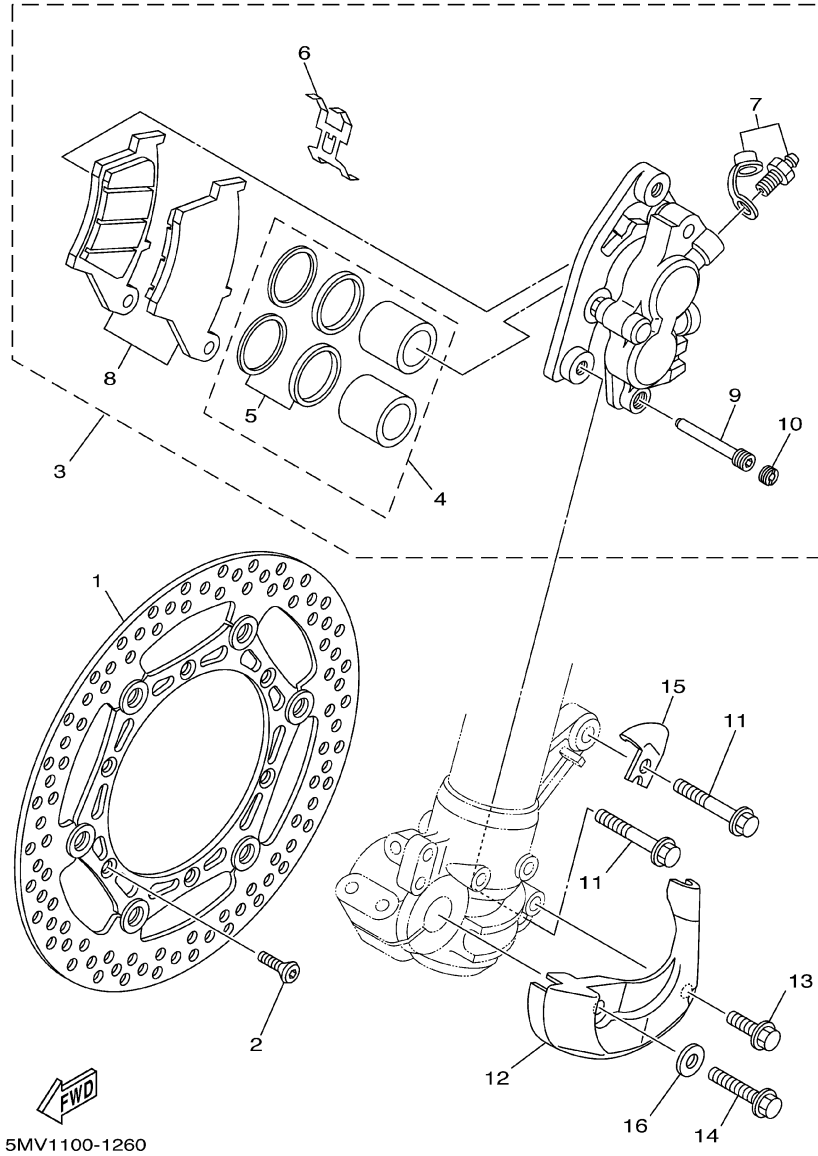

REF. NO.	PART NO.	DESCRIPTION	5MW1	5MW2	5MW3	5MW4	REMARKS
1	5MV-2581T-00	DISC BRAKE ASSY	1	1	1	1	
2	90149-06327	SCREW	6	6	6	6	
3	5MV-2580T-10	CALIPER ASSY (LEFT)	1	1	1	1	
4	4EW-W0057-00	.PISTON ASSY, CALIPER	1	1	1	1	
5	3JD-W0047-00	..CALIPER SEAL KIT	1	1	1	1	
6	5DH-25919-00	.SUPPORT, PAD	1	1	1	1	
7	1UY-W0048-50	.BLEED SCREW KIT	1	1	1	1	
8	5MV-W0045-00	.BRAKE PAD KIT	1	1	1	1	
9	5DH-25933-00	.PIN, PAD	1	1	1	1	
10	5DH-25916-00	.PLUG	1	1	1	1	
11	90105-08659	BOLT, FLANGE	2	2	2	2	
12	5DH-2314E-00	COVER, HOSE	1	1	1	1	
13	95827-06012	BOLT, FLANGE	1	1	1	1	
14	95027-08020	BOLT, FLANGE	1	1	1	1	
15	5DH-25875-00	HOLDER, BRAKE HOSE 1	1	1	1	1	
16	92907-08200	WASHER	1	1	1	1	

FIG. 27 REAR WHEEL

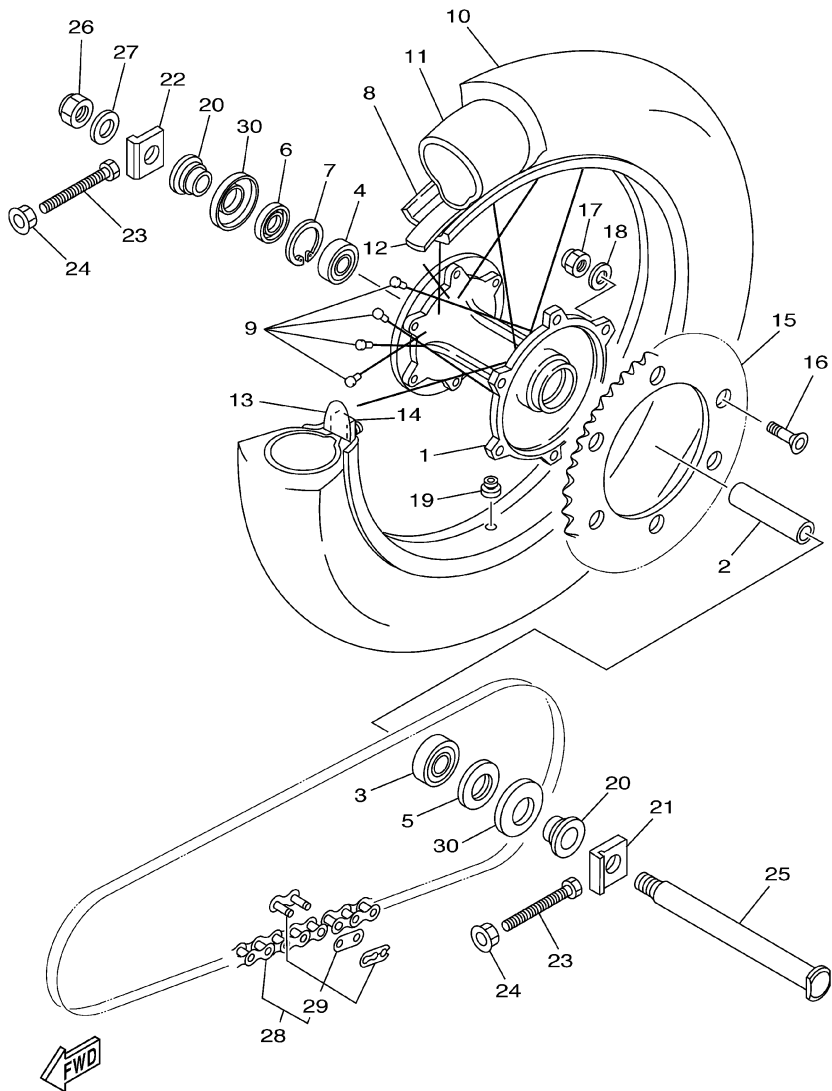

5MW1100-1270

REF. NO.	PART NO.	DESCRIPTION	5MW1	5MW2	5MW3	5MW4	REMARKS
1	5ET-25311-00	HUB, REAR	1	1	1	1	
2	5ET-25317-00	SPACER, BEARING	1	1	1	1	
3	93306-27205	BEARING	1	1	1	1	
4	93306-07202	BEARING	1	1	1	1	
5	93106-30044	OIL SEAL	1	1	1	1	
6	93106-30045	OIL SEAL	1	1	1	1	
7	99009-45500	CIRCLIP	1	1	1	1	
8	94421-19602	RIM (2.15-19)	1	1	1	1	
9	5HD-25304-00	SPOKE SET, REAR	1	1	1	1	
10	94111-1916B	TIRE (110/90-19 D739)	1			1	UR DUNLOP
	94111-1913A	TIRE (110/90-19 62M D755)	1	1			UR DUNLOP FOR CAN
	94111-1916C	TIRE (110/90-19 M78A)			1		BRIDGESTONE
11	94211-19273	TUBE (110/90 110/100-19TR4)	1	1		1	DUNLOP
	94211-19274	TUBE (MCS 110/90-19 TR4)			1		BRIDGESTONE
12	94311-19155	BAND, RIM (110/90 110/100-19)	1	1		1	DUNLOP
	94321-19157	BAND, RIM (2.15-19)			1		BRIDGESTONE
13	3JE-25394-00	SPACER, BEAD	1	1	1	1	
14	4XM-25364-00	DAMPER	1	1	1	1	
15	5ET-25450-00	SPROCKET, DRIVEN (50T)	1	1	1	1	STD
	5ET-25447-00	SPROCKET, DRIVEN (47T)	1	1	1	1	AP
	5ET-25448-00	SPROCKET, DRIVEN (48T)	1	1	1	1	AP
	5ET-25449-00	SPROCKET, DRIVEN (49T)	1	1	1	1	AP
	5ET-25451-00	SPROCKET, DRIVEN (51T)	1	1	1	1	AP
	5ET-25452-00	SPROCKET, DRIVEN (52T)	1	1	1	1	AP
16	90109-081G1	BOLT	6	6	6	6	
17	90185-08169	NUT, SELF-LOCKING	6	6	6	6	
18	90201-08326	WASHER, PLATE	6	6	6	6	

FIG. 27 REAR WHEEL

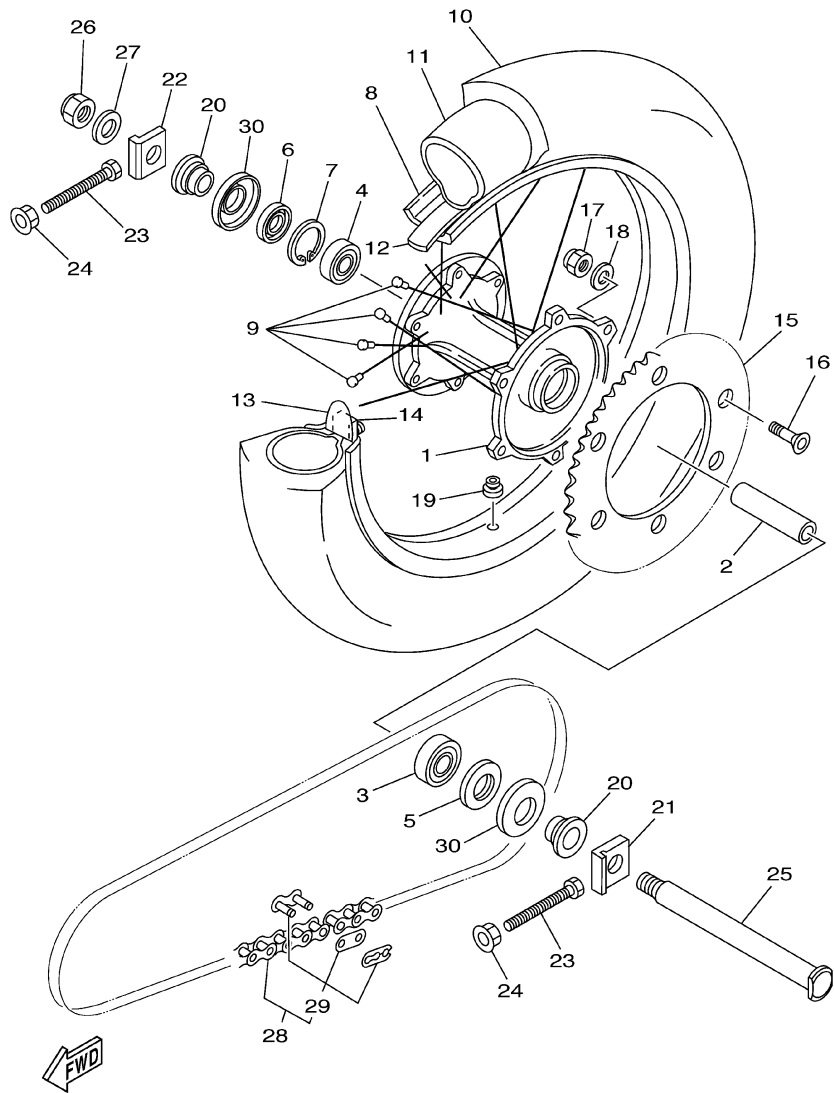

5MW1100-1270

REF. NO.	PART NO.	DESCRIPTION	5MW1	5MW2	5MW3	5MW4	REMARKS
19	90480-08608	GROMMET	1	1	1	1	
20	5ET-25383-00	COLLAR, WHEEL	2	2	2	2	
21	5ET-25388-00	PULLER, CHAIN 1	1	1	1	1	
22	5ET-25389-00	PULLER, CHAIN 2	1	1	1	1	
23	90101-08777	BOLT	2	2	2	2	
24	90179-08299	NUT	2	2	2	2	
25	5ET-25381-00	AXLE, WHEEL	1	1	1	1	
26	90185-20168	NUT, SELF-LOCKING	1	1	1	1	
27	90201-203U1	WASHER, PLATE	1	1	1	1	
28	9Y581-92113	CHAIN	1	1	1	1	
29	94681-68001	JOINT, CHAIN	1	1	1	1	
30	5ET-25367-00	COVER, HUB DUST	2	2	2	2	

FIG. 28 REAR BRAKE CALIPER

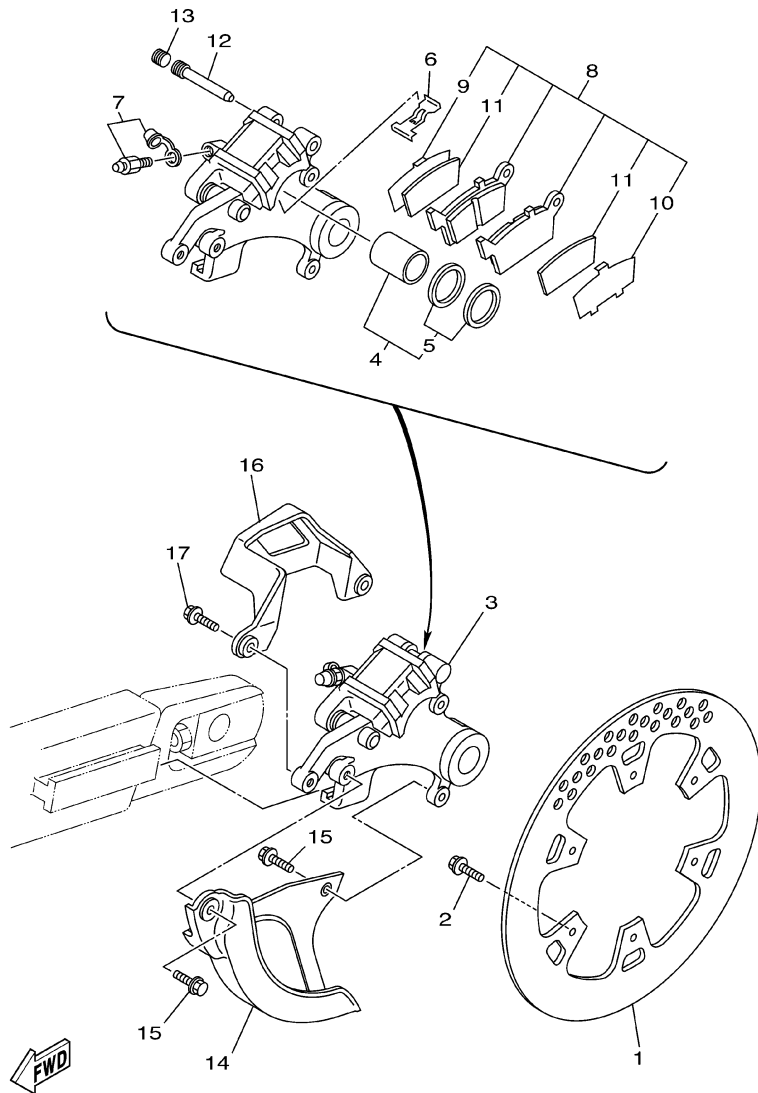

5ET1100-9280

REF. NO.	PART NO.	DESCRIPTION	5MW1	5MW2	5MW3	5MW4	REMARKS
1	5DH-2582W-00	DISC, REAR BRAKE 2	1	1	1	1	
2	90109-065G4	BOLT	6	6	6	6	
3	5ET-2580W-00	CALIPER ASSY, REAR 2	1		1	1	
	5MV-2580W-00	CALIPER ASSY, REAR 2		1			
4	5ET-W0057-50	.PISTON ASSY, CALIPER	1	1	1	1	
5	5ET-W0047-50	..CALIPER SEAL KIT	1	1	1	1	
6	5DH-25919-50	..SUPPORT, PAD	1	1	1	1	
7	1UY-W0048-50	..BLEED SCREW KIT	1	1	1	1	
8	5ET-W0046-00	..BRAKE PAD KIT 2	1		1	1	
	5MV-W0046-00	..BRAKE PAD KIT 2		1			
9	5DH-25828-50	..SHIM, CALIPER	1	1	1	1	
10	5DH-25827-50	..SHIM, CALIPER	1	1	1	1	
11	5DH-22898-50	..INSULATOR, HEAT	2	2	2	2	
12	8CR-25924-00	..PIN, PAD	1	1	1	1	
13	5DH-25916-00	..PLUG	1	1	1	1	
14	5DH-25718-01	PROTECTOR, DISK BRAKE	1	1	1	1	
15	95027-06012	BOLT, FLANGE	2	2	2	2	
16	4GY-27491-00	PROTECTOR	1	1	1	1	
17	95027-06016	BOLT, FLANGE	2	2	2	2	

FIG. 29 STEERING HANDLE. CABLE

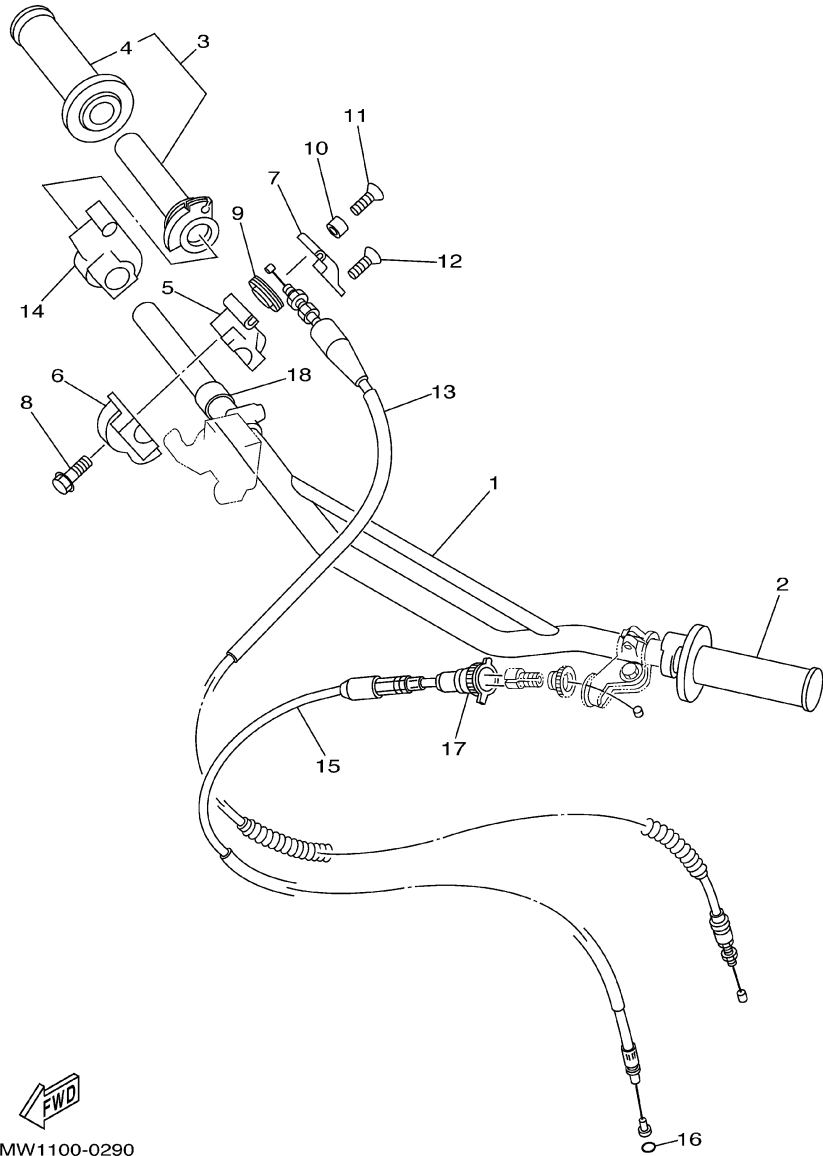

5MW1100-0290

REF. NO.	PART NO.	DESCRIPTION	5MW1	5MW2	5MW3	5MW4	REMARKS
1	4XM-26111-00	HANDLEBAR	1	1	1	1	
2	4GY-26241-00	GRIP	1	1	1	1	
3	4XM-26240-00	GRIP ASSY	1	1	1	1	
4	4GY-26242-00	.GRIP (RIGHT)	1	1	1	1	
5	4SS-26281-00	CAP, GRIP UPPER	1	1	1	1	
6	4SS-26282-10	CAP, GRIP LOWER	1	1	1	1	
7	4SS-2628H-00	CAP, WIRE	1	1	1	1	
8	95027-06025	BOLT, FLANGE	2	2	2	2	
9	4SS-26273-00	ROTOR	1	1	1	1	
10	4SS-26259-00	COLLAR	1	1	1	1	
11	4SS-26256-00	SCREW, GRIP END	1	1	1	1	
12	4SS-2632G-00	SCREW	1	1	1	1	
13	5HC-26311-00	CABLE, THROTTLE 1	1	1	1	1	
14	4SS-26287-01	COVER, CAP GRIP	1	1	1	1	
15	5HC-26335-10	CABLE, CLUTCH	1	1	1	1	
16	93210-06001	O-RING	1	1	1	1	
17	5HD-26342-00	BOOT, CABLE	1	1	1	1	
18	90387-227H7	COLLAR	1	1	1	1	

FIG. 30 FRONT MASTER CYLINDER

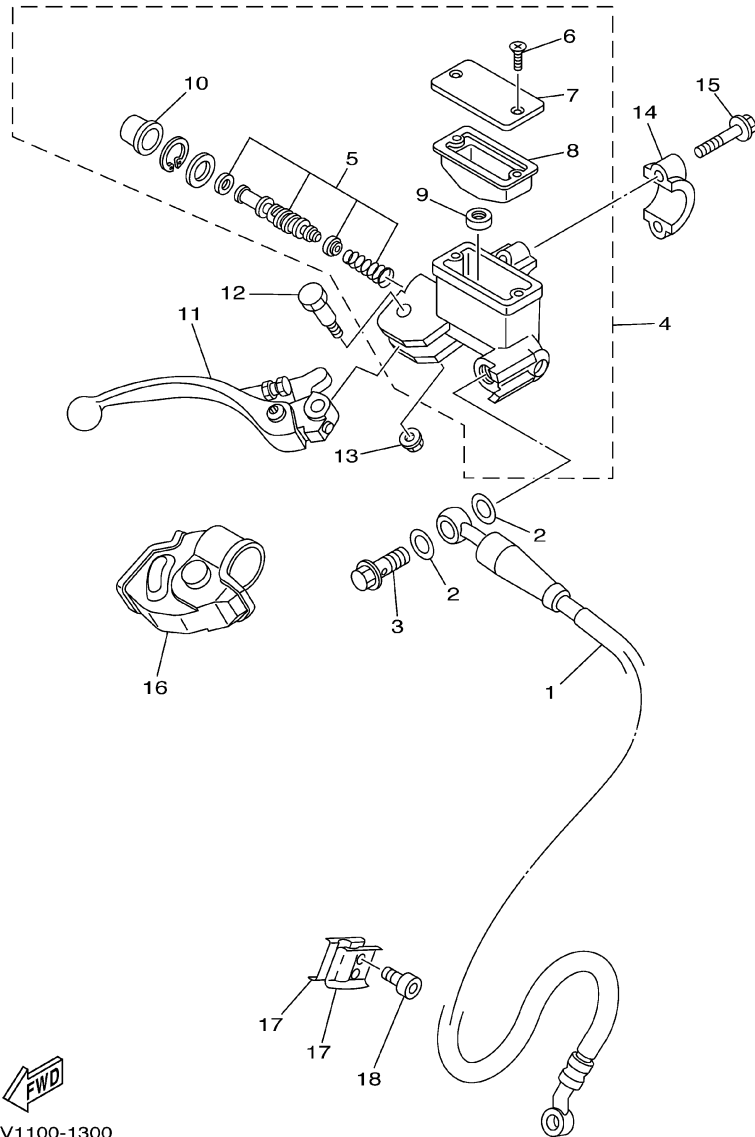

5MV1100-1300

REF. NO.	PART NO.	DESCRIPTION	5MW1	5MW2	5MW3	5MW4	REMARKS
1	5HD-25872-00	HOSE, BRAKE 1		1	1	1	
	5ET-25872-00	HOSE, BRAKE 1	1				
2	90201-10118	WASHER, PLATE	4	4	4	4	
3	90401-10168	BOLT, UNION	2	2	2	2	
4	5MV-W2587-00	MASTER CYLINDER SUB ASSY	1	1	1	1	
5	5MV-W0041-00	.CYLINDER KIT, MASTER	1	1	1	1	
6	98706-04012	.SCREW, FLAT HEAD	2	2	2	2	
7	5MV-25852-00	.CAP, RESERVOIR	1	1	1	1	
8	56A-25854-00	.DIAPHRAGM, RESERVOIR	1	1	1	1	
9	8CR-25715-00	.SEPARATOR ASSY	1	1	1	1	
10	5G2-25868-00	.BOOT, MASTER CYLINDER	1	1	1	1	
11	5MV-83922-00	LEVER 2	1	1	1	1	
12	5MV-2589F-00	BOLT, LEVER	1	1	1	1	
13	95701-06500	NUT, FLANGE	1	1	1	1	
14	5MV-25867-00	BRACKET, MASTER CYLINDER	1	1	1	1	
15	5MV-25833-00	BOLT, FITTING	2	2	2	2	
16	5MV-26372-00	COVER, HANDLE LEVER 1	1	1	1	1	
17	90465-16258	CLAMP	2	2	2	2	
18	91317-06014	BOLT	2	2	2	2	

FIG. 31 STAND, FOOTREST

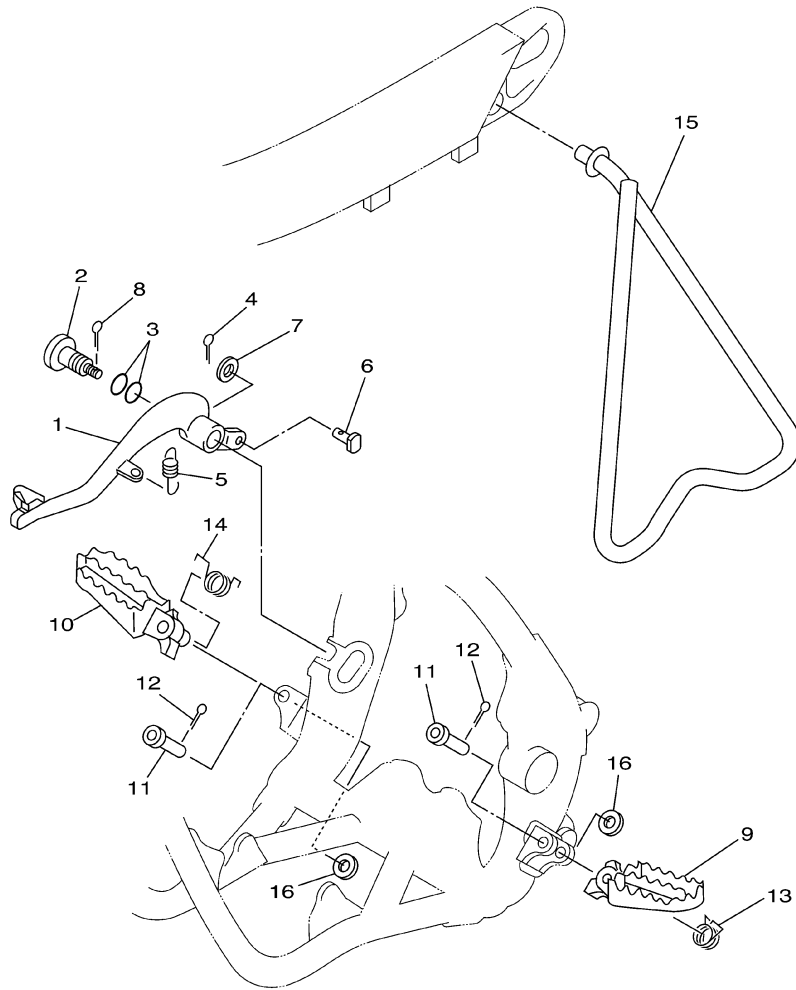

4XL4100-7310

REF. NO.	PART NO.	DESCRIPTION	5MW1	5MW2	5MW3	5MW4	REMARKS
1	4XM-27200-00	PEDAL, BRAKE	1	1	1	1	
2	5JG-27217-00	BOLT	1	1	1	1	
3	93210-11073	O-RING	2	2	2	2	
4	91401-20012	PIN, COTTER	1	1	1	1	
5	90506-16500	SPRING, TENSION	1	1	1	1	
6	90240-08120	PIN, CLEVIS	1	1	1	1	
7	90201-08089	WASHER, PLATE	1	1	1	1	
8	90468-16191	CLIP	1	1	1	1	
9	5ET-27411-00	FOOTREST 1	1	1	1	1	
10	5ET-27421-00	FOOTREST 2	1	1	1	1	
11	90240-10142	PIN, CLEVIS	2	2	2	2	
12	91401-25015	PIN, COTTER	2	2	2	2	
13	90508-282B8	SPRING, TORSION	1	1	1	1	
14	90508-282B9	SPRING, TORSION	1	1	1	1	
15	5ET-27311-00	STAND, SIDE	1	1	1	1	
16	90201-10119	WASHER, PLATE	2	2	2	2	

FIG. 32 REAR MASTER CYLINDER

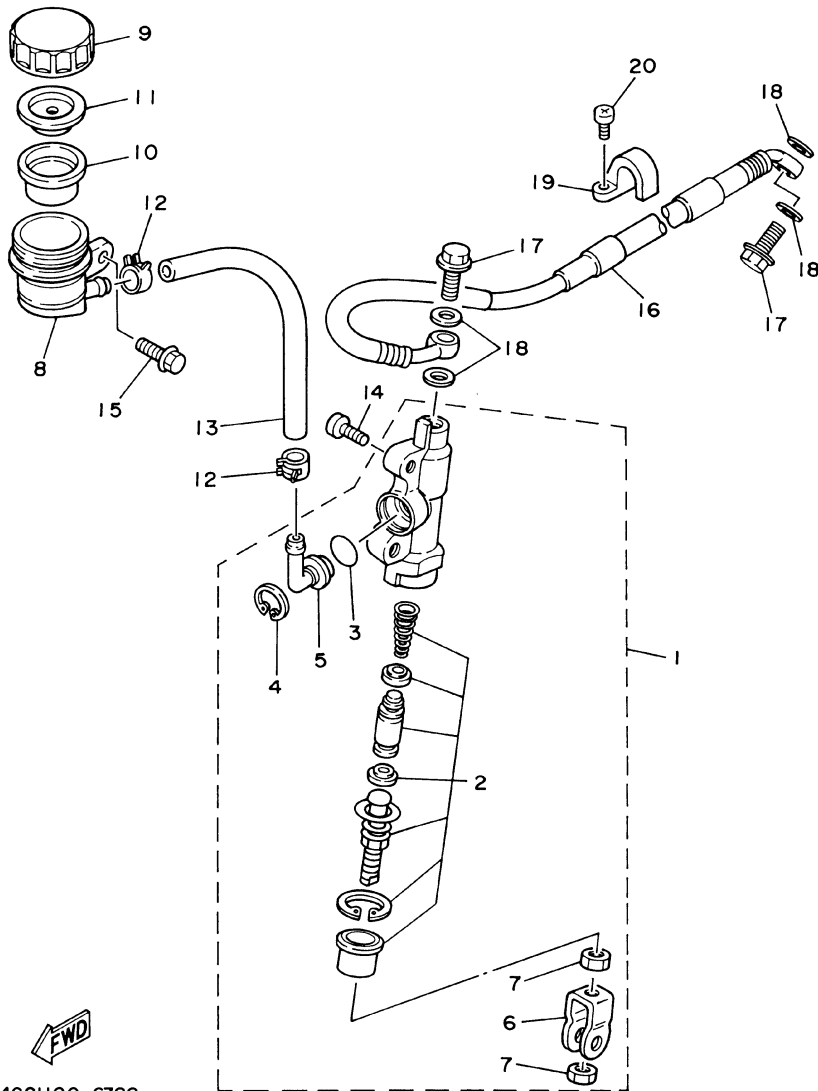

REF. NO.	PART NO.	DESCRIPTION	5MW1	5MW2	5MW3	5MW4	REMARKS
1	3SP-2583V-00	RR. MASTER CYLINDER ASSY.	1	1	1	1	
2	4SS-W0042-50	.CYLINDER KIT, MASTER	1	1	1	1	
3	93210-15620	.O-RING	1	1	1	1	
4	2VN-25866-00	.CIRCLIP	1	1	1	1	
5	2VN-2582A-50	.JOINT	1	1	1	1	
6	3SP-27222-00	.JOINT	1	1	1	1	
7	4SS-27218-00	.NUT	2	2	2	2	
8	4EW-25894-00	TANK, RESERVOIR	1	1	1	1	
9	3XP-25852-50	CAP, RESERVOIR	1	1	1	1	
10	2VN-25854-00	DIAPHRAGM, RESERVOIR	1	1	1	1	
11	2VN-25855-00	BUSH,DIAPHRAGM	1	1	1	1	
12	90467-12053	CLIP	2	2	2	2	
13	90445-137H9	HOSE	1	1	1	1	
14	92014-06016	BOLT, BUTTON HEAD	2	2	2	2	
15	95027-06012	BOLT, FLANGE	1	1	1	1	
16	5MV-25873-00	HOSE, BRAKE 2	1	1	1	1	
17	90401-10168	BOLT, UNION	2	2	2	2	
18	90201-10118	WASHER, PLATE	4	4	4	4	
19	2VM-25876-00	HOLDER, BRAKE HOSE 2	2	2	2	2	
20	97780-50510	SCREW, TAPPING	4	4	4	4	

FIG. 33 GENERATOR

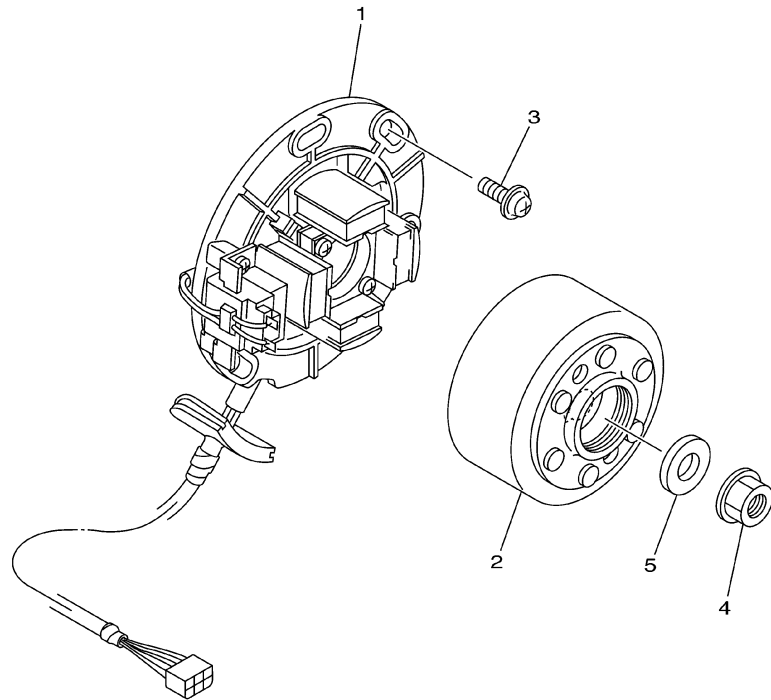

REF. NO.	PART NO.	DESCRIPTION	5MW1	5MW2	5MW3	5MW4	REMARKS
1	5CU-85560-00	BASE ASSY	1	1	1	1	
2	5CU-85550-10	ROTOR ASSY	1	1	1	1	
3	90149-06011	SCREW	3	3	3	3	
4	90179-10394	NUT	1	1	1	1	
5	90201-10591	WASHER, PLATE	1	1	1	1	
<hr style="border-top: 1px dashed black;"/>							
<hr style="border-top: 1px dashed black;"/>							
<hr style="border-top: 1px dashed black;"/>							
<hr style="border-top: 1px dashed black;"/>							
<hr style="border-top: 1px dashed black;"/>							
<hr style="border-top: 1px dashed black;"/>							
<hr style="border-top: 1px dashed black;"/>							
<hr style="border-top: 1px dashed black;"/>							
<hr style="border-top: 1px dashed black;"/>							
<hr style="border-top: 1px dashed black;"/>							

5CU1100-9330

FIG. 34 HANDLE SWITCH. LEVER

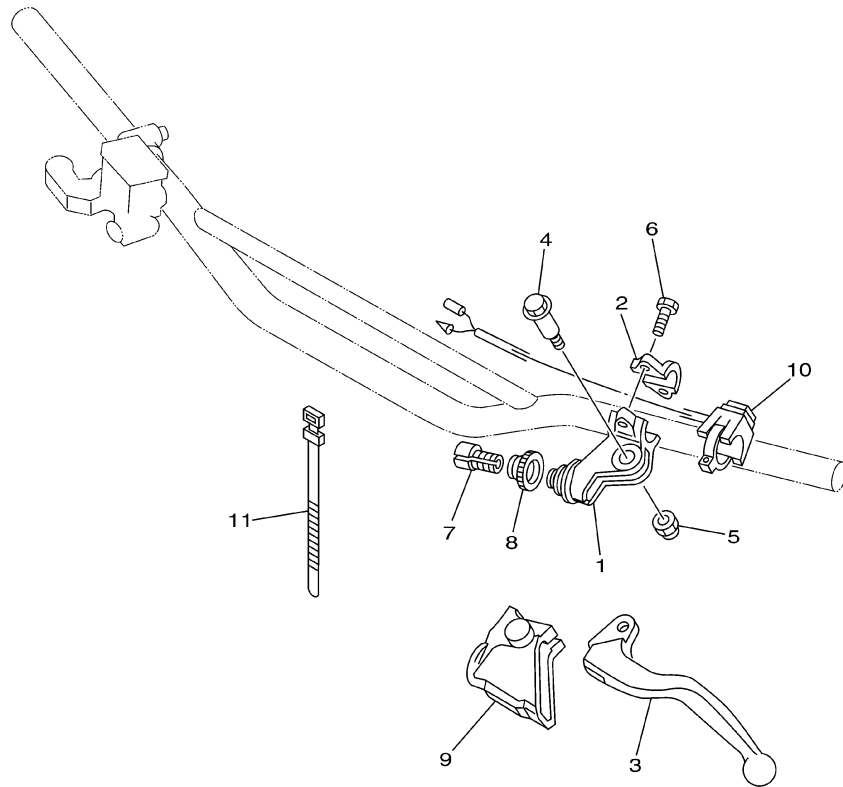

REF. NO.	PART NO.	DESCRIPTION	5MW1	5MW2	5MW3	5MW4	REMARKS
1	5HD-82911-00	HOLDER, LEVER 1	1	1	1	1	
2	38V-82913-00	HOLDER, LEVER LOWER 1	1	1	1	1	
3	5MV-83912-00	LEVER 1	1	1	1	1	
4	90109-06027	BOLT	1	1	1	1	
5	95607-06100	NUT, U	1	1	1	1	
6	97007-05016	BOLT	2	2	2	2	
7	5HD-26337-00	BOLT, ADJUSTING	1	1	1	1	
8	5HD-83951-00	BOLT, CABLE ADJUSTING	1	1	1	1	
9	5HD-26372-00	COVER, HANDLE LEVER 1	1	1	1	1	
10	23X-83976-00	SWITCH, HANDLE 1	1	1	1	1	
11	90464-13077	CLAMP	2	2	2	2	



5HD1100-0340

FIG. 35 ELECTRICAL 1

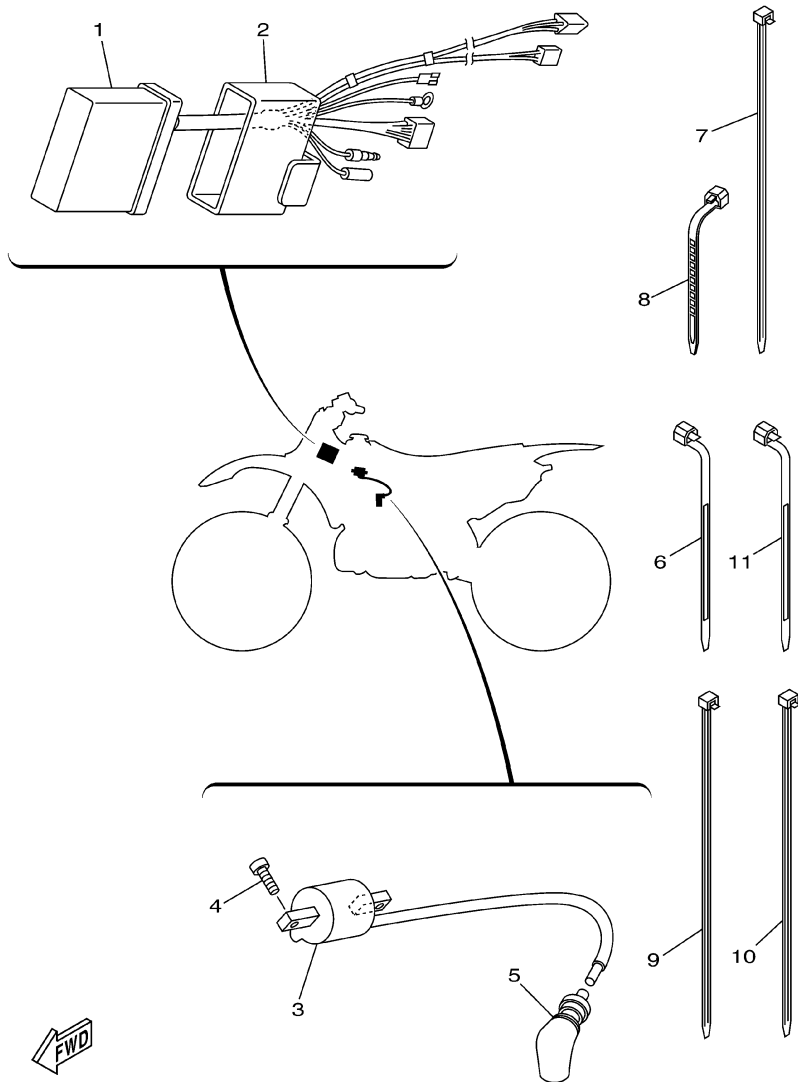

REF. NO.	PART NO.	DESCRIPTION	5MW1	5MW2	5MW3	5MW4	REMARKS
1	5HC-85540-00	C.D.I. UNIT ASSY	1			1	
	5MW-85540-00	C.D.I. UNIT ASSY		1			
2	5CU-85546-00	BAND	1	1	1	1	
3	5BE-82310-00	IGNITION COIL ASSY	1	1	1	1	
4	95027-06016	BOLT, FLANGE	2	2	2	2	
5	4PE-82370-10	PLUG CAP ASSY	1	1	1	1	
6	90464-15195	CLAMP	1	1	1	1	
7	90464-50255	CLAMP	2	2	2	2	
8	90464-13073	CLAMP	1	1	1	1	
9	90464-50255	CLAMP	1	1	1	1	
10	90464-50255	CLAMP	1	1	1	1	
11	90464-15195	CLAMP	1	1	1	1	

FWD
5MW1100-1350

FIG. 36 ALTERNATE (CHASSIS)

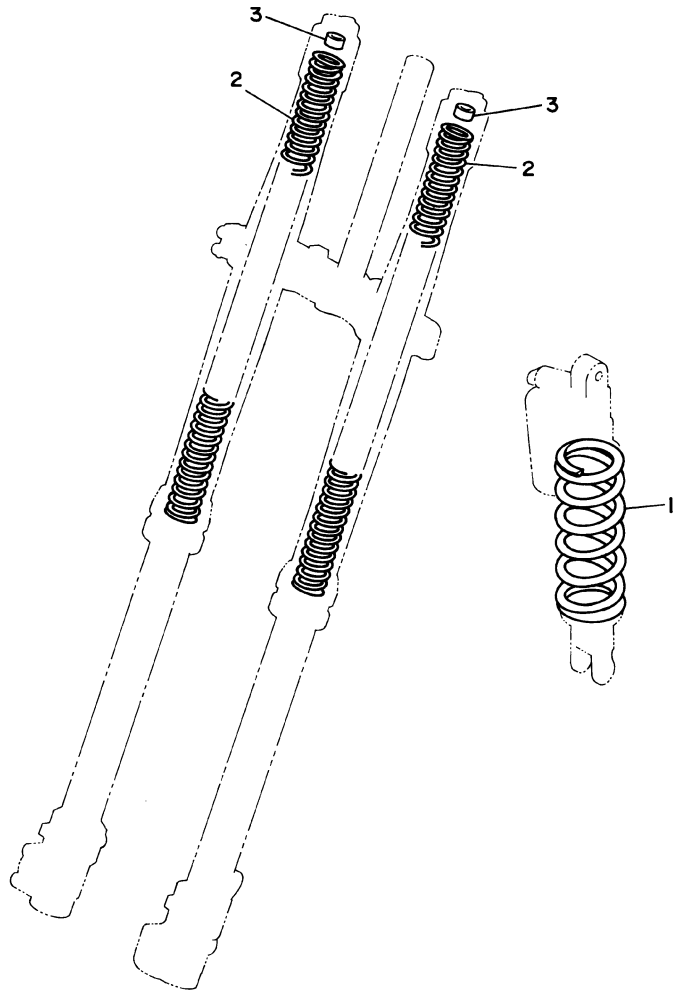

3XJI100-1360

REF. NO.	PART NO.	DESCRIPTION	5MW1	5MW2	5MW3	5MW4	REMARKS
1	5DH-22212-10	SPRING (K=4.6)	1	1	1	1	AP
	5DH-22212-20	SPRING (K=4.8)	1	1	1	1	AP
	5DH-22212-30	SPRING (K=5.0)	1	1	1	1	AP
	5DH-22212-40	SPRING (K=5.2)	1	1	1	1	AP
	5DH-22212-50	SPRING (K=5.4)	1	1	1	1	AP
	5DH-22212-60	SPRING (K=5.6)	1	1	1	1	AP
	5DH-22212-70	SPRING (K=4.4)	1	1	1	1	AP
	5ET-22212-10	SPRING (K=APPROX.5.0)	1	1	1	1	AP
	5ET-22212-20	SPRING (K=APPROX.4.6)	1	1	1	1	AP
	5ET-22212-30	SPRING (K=APPROX.5.2)	1	1	1	1	AP
	5ET-22212-40	SPRING (K=APPROX.5.4)	1	1	1	1	AP
	5ET-22212-00	SPRING (K=APPROX.4.8)	1	1	1	1	AP
2	4SS-23141-10	SPRING, FRONT FORK (K=0.38)	2	2	2	2	AP
	4SS-23141-20	SPRING, FRONT FORK (K=0.39)	2	2	2	2	AP
	4SS-23141-30	SPRING, FRONT FORK (K=0.40)	2	2	2	2	AP
	4SS-23141-40	SPRING, FRONT FORK (K=0.41)	2	2	2	2	AP
	4SS-23141-50	SPRING, FRONT FORK (K=0.42)	2	2	2	2	AP
	4SS-23141-60	SPRING, FRONT FORK (K=0.43)	2	2	2	2	AP
	4SS-23141-70	SPRING, FRONT FORK (K=0.44)	2	2	2	2	AP
	5ET-23141-00	SPRING (K=APPROX.0.41)	2	2	2	2	AP
	5ET-23141-10	SPRING (K=APPROX.0.43)	2	2	2	2	AP
	5ET-23141-20	SPRING (K=APPROX.0.40)	2	2	2	2	AP
	5ET-23141-30	SPRING (K=APPROX.0.42)	2	2	2	2	AP
	5ET-23141-40	SPRING (K=APPROX.0.44)	2	2	2	2	AP
3	4SS-23364-L0	COLLAR 2	1	1	1	1	UN

FIG. 37 OPTIONAL PARTS 1

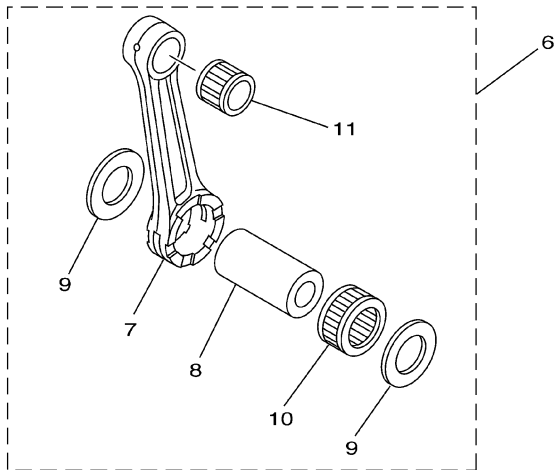
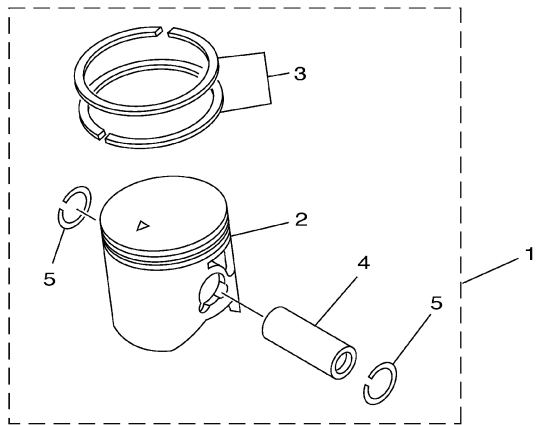

REF. NO.	PART NO.	DESCRIPTION	5MW1	5MW2	5MW3	5MW4	REMARKS
1	5MW-11630-00	PISTON ASSY (STD)	1	1	1	1	
2	5MW-11631-00-B0	.PISTON (STD)	1	1	1	1	
3	5CU-11603-10	.PISTON RING SET (STD)	1	1	1	1	
4	5MW-11633-00	.PIN, PISTON	1	1	1	1	
5	93450-19052	.CIRCLIP	2	2	2	2	
6	5MW-11650-00	CONNECTING ROD ASSY	1	1	1	1	
7	5MW-11651-00	.ROD, CONNECTING	1	1	1	1	
8	5CU-11681-00	.PIN, CRANK 1	1	1	1	1	
9	90209-24327	.WASHER	2	2	2	2	
10	93310-52406	.BEARING	1	1	1	1	
11	93310-218A6	.BEARING	1	1	1	1	



5MW1100-1370

NUMERICAL INDEX

PARTNO.	GRID NO.	PARTNO.	GRID NO.	PARTNO.	GRID NO.	PARTNO.	GRID NO.	PARTNO.	GRID NO.	PARTNO.	GRID NO.
5MV-W0041-00	D - 14	5X4-11921-02	B - 4	5HC-14261-00	B - 10	4JT-1494F-11	B - 11	5CU-15664-00	C - 2	5CU-21425-00	C - 9
4SS-W0042-50	E - 2	3JE-11922-01	B - 4	5HC-14264-00	B - 11	4JT-1494F-13	B - 11	3Y6-15674-00	C - 2	5HD-21511-00	C - 10
5MV-W0045-00	D - 9	5CU-11952-00	B - 4	5HC-14275-00	B - 11	4JT-1494F-15	B - 11	214-15686-00	C - 2	4XL-2153A-10	D - 5
5ET-W0046-00	D - 12	24X-11953-01	B - 4	5HC-14340-A7	B - 10	4MX-14943-40	B - 10	5DJ-16111-00	C - 3	4ES-2153E-01	C - 10
5MV-W0046-00	D - 12	5CU-11956-00	C - 3	4MX-14392-00	B - 9	4MX-14943-41	B - 11	5MW-16113-00	C - 3	5BE-21611-10	C - 10
3JD-W0047-00	D - 9	5CU-11990-00	B - 4	4SS-14401-10	B - 8	4MX-14943-42	B - 11	5DJ-16150-00	C - 3	5BE-21642-00	C - 10
5ET-W0047-50	D - 12	5CU-11991-00	B - 3	4SS-14417-00	B - 8	4MX-14943-43	B - 10	2K7-16154-00	C - 3	4SS-21711-00	C - 11
1UY-W0048-50	D - 12	5CU-11993-00	B - 3	5BE-14449-00	B - 12			5CU-16154-00	C - 3	4EW-2172A-00	C - 11
	D - 9	5CU-11995-00	B - 3	4XM-14451-00	B - 8	4MX-14943-44	B - 11	2VM-16181-00	C - 3	4SS-21721-00	C - 11
4EW-W0057-00	D - 9	4SR-1240A-10	B - 7	5HC-14453-00	B - 8	4MX-14943-45	B - 11	3XK-16321-00	C - 3	5MV-2173E-00	C - 11
5ET-W0057-50	D - 12	5MW-12422-00	B - 6	3JD-14458-01	B - 8	4MX-14943-91	B - 11	4X7-16325-00	C - 3	5MV-2173F-00	C - 11
5MV-W2587-00	D - 14	5CU-12428-00	B - 6	3JD-14459-01	B - 8	4MX-14943-92	B - 11	5HC-16351-00	C - 3	5ET-21730-10	C - 11
5MW-11111-00	B - 2	5DJ-12451-00	B - 6	3JD-14462-00	B - 8	4MX-14943-93	B - 10	4XL-16356-00	C - 3	5ET-21740-10	C - 11
5CU-1131D-00	B - 2	5CU-12459-00	B - 6	5MV-14477-00	B - 8			5CU-16357-10	C - 3	3JD-21748-00	C - 10
5CU-1131E-00	B - 2	4SR-12461-10	B - 7	676-14548-00	B - 10	4MX-14943-94	B - 11	4EW-16371-01	C - 3	5MV-2175C-00	C - 11
5CU-1131M-00	B - 3	5HD-12462-00	B - 7	4YR-14557-00	B - 12	4MX-14943-95	B - 11	5CU-16380-10	C - 3	5MW-21781-00	C - 10
5CU-1131P-00	B - 2	5CU-12481-00	B - 7	4MX-14561-00	B - 9	4SR-14943-90	B - 10	5BE-17121-00	C - 5	5MV-22110-00	C - 12
5CU-1131U-10	B - 2	4SS-12482-00	B - 7	5BE-14562-00	B - 12	4MX-14948-04	B - 9	5CU-17131-00	C - 5	4XM-22128-00	C - 12
5CU-1131V-00	B - 3	5MW-12483-00	B - 7	5MW-14610-00	B - 13	4MX-14948-05	B - 9	5BE-17141-20	C - 5	5DH-22141-00	C - 12
5MW-11311-00	B - 2	5CU-12484-00	B - 7	5MW-14610-10	B - 13	4MX-14948-06	B - 9	5BE-17151-00	C - 5	5MV-22151-00	C - 12
5CU-1132A-00	B - 2	353-13115-01	B - 14	3JE-14615-01	B - 13	4MX-14948-07	B - 9	5BE-17211-00	C - 5	5JG-22156-00	C - 12
5MW-1132E-00	B - 3		B - 3	5MW-14642-00	B - 13	4MX-14948-08	B - 9	5BE-17221-00	C - 5	5ET-2217A-00	C - 12
5MW-1132F-00	B - 3	5HC-13565-00	B - 8	5CU-1469A-00	B - 13	4MX-14948-09	B - 9	5BE-17231-00	C - 5	5DH-2217F-01	C - 13
5CU-11351-10	B - 2	4XL-13610-00	B - 8	5HC-1469A-10	B - 13	4MX-14948-10	B - 9	5BE-17241-10	C - 5	5MV-22176-00	C - 14
5CU-11354-00	B - 3	4XL-13613-00	B - 8	5HC-14753-00	B - 13	4MX-14948-11	B - 9	5BE-17251-10	C - 5	3JD-22178-10	C - 9
5MW-11400-00	B - 5	4XL-13616-00	B - 8	5MW-14753-10	B - 13	4MX-14948-12	B - 9	5BE-17411-00	C - 5	4EW-22178-00	C - 9
5CU-11410-00	B - 5	4XL-13625-00	B - 8	5CU-14771-00	B - 13	4SR-14948-02	B - 9	5BE-17421-00	C - 5	5MV-22184-00	C - 14
5MW-11420-00	B - 5	4XL-1410E-00	B - 11	483-14781-02	B - 13	4SR-14948-03	B - 9	5HC-17466-00	B - 15	4XM-22199-00	C - 12
5CU-11603-10	B - 5	5HC-1410H-00	B - 11	4JT-14916-9G	B - 9	4JT-14984-00	B - 9	4L0-17471-00	B - 14	5MW-22201-00	C - 14
	E - 7	5MW-14101-00	B - 9	4JT-14916-9H	B - 10	4SR-14985-00	B - 9	5CU-18101-00	C - 8	5MW-22201-10	C - 14
5MW-11630-00	E - 7	5MW-14101-10	B - 9	4JT-14916-9J	B - 10	5CU-15111-01	B - 14	5CU-18110-00	C - 8	5MW-22201-20	C - 14
5MW-11631-00-A0	B - 5	5MW-14101-20	B - 9	4JT-14916-9W	B - 10	4V4-15118-00	B - 14	5MW-18122-00	C - 8	5MW-22201-30	C - 14
5MW-11631-00-B0	B - 5	4SR-14105-00	B - 10	4SR-14916-CG	B - 10	5CU-15118-00	B - 14	4BR-18127-00	C - 7	5MW-22201-40	C - 14
	E - 7	4MX-14115-00	B - 9	4SR-14916-CH	B - 10	5CU-15121-01	B - 14	5CU-18140-01	C - 7	5MW-22210-00	C - 14
5MW-11631-00-C0	B - 5	5HC-14126-00	B - 10	4SR-14916-CJ	B - 10	3Y1-15363-00	B - 15	5CU-18172-00	C - 8	5MW-22210-10	C - 14
5MW-11631-00-D0	B - 5	5HC-14131-00	B - 10		B - 9	4JT-15381-01	B - 14	3XJ-18173-00	C - 8	5MW-22210-20	C - 14
5MW-11633-00	B - 5	3TJ-14137-40	B - 10	4SR-14916-CW	B - 10	5CU-15411-00	B - 15	3XJ-18178-00	C - 8	5MW-22210-30	C - 14
	E - 7	4XL-14146-00	B - 9		B - 9	5MW-15415-00	B - 15	3XJ-18182-00	C - 8	5MW-22210-40	C - 14
5MW-11650-00	E - 7	5HC-14146-00	B - 11	4SR-14916-EG	B - 10	5CU-15421-00	B - 15	3XJ-18184-00	C - 8	5DH-22212-10	E - 6
5MW-11651-00	B - 5	4JT-14147-00	B - 11	4SR-14916-EH	B - 10	5CU-15431-00	B - 15	4EW-18185-00	C - 7	5DH-22212-20	C - 14
	E - 7	663-14159-00	B - 10	4SR-14916-EJ	B - 10	5CU-15451-00	B - 15	5BE-18501-00	C - 7		E - 6
5CU-11681-00	B - 5	4JT-14171-00	B - 9		B - 9	5CU-15454-00	B - 14	5BE-18502-10	C - 7	5DH-22212-30	E - 6
	E - 7	4MX-14194-00	B - 11	4SR-14916-EW	B - 10	5CU-15462-00	B - 15	5CU-18503-00	C - 7	5DH-22212-40	E - 6
5CU-11830-00	B - 2	4XL-14196-10	B - 10	4MX-14919-00	B - 10	5CU-15463-00	B - 15	5MW-18541-00	C - 7	5DH-22212-50	E - 6
4SS-11832-00	B - 3	4XL-14197-10	B - 10	5HC-14922-00	B - 11	5CU-15601-01	C - 2	5DH-18562-00	C - 7	5DH-22212-60	E - 6
5CU-11911-00	B - 4	5HC-14208-00	B - 12	5HC-14934-00	B - 12	4EW-15620-02	C - 2	5MW-21101-00-P0	C - 9	5DH-22212-70	E - 6
5CU-11912-00	B - 4	4YR-14216-00	B - 12	4JT-1494F-07	B - 11	3SP-15621-02	C - 2	5HC-21190-00-P0	C - 9	5ET-22212-00	E - 6
4JY-11915-01	B - 4	5HC-14216-00	B - 12	4JT-1494F-09	B - 11	5CU-15651-00	C - 2	5HD-2135F-00	C - 13	5ET-22212-10	C - 14

NUMERICAL INDEX

PARTNO.	GRID NO.	PARTNO.	GRID NO.	PARTNO.	GRID NO.	PARTNO.	GRID NO.	PARTNO.	GRID NO.	PARTNO.	GRID NO.
5ET-22212-10	E - 6	4SS-23141-70	E - 6	5HD-23393-L0	D - 3	5MV-2580T-10	D - 9	5MV-26372-00	D - 14	90119-06096	C - 10
5ET-22212-20	E - 6	4XL-23141-L0	D - 3			5ET-2580W-00	D - 12	4XM-27200-00	D - 15	90119-06192	B - 13
5ET-22212-30	E - 6			4EW-23416-00	D - 2	5MV-2580W-00	D - 12	5JG-27217-00	D - 15		C - 10
5ET-22212-40	E - 6	5CU-23141-L0	D - 3	5HC-23435-00	D - 2	5MV-2581T-00	D - 9	4SS-27218-00	E - 2	90119-06203	B - 8
3SP-22213-00	C - 14			5HC-23435-11	D - 2	2VN-2582A-50	E - 2	3SP-27222-00	E - 2	90119-06214	B - 7
5DH-22214-00	C - 14	5ET-23141-00	E - 6	3SP-23441-00	D - 2	5DH-2582W-00	D - 12	5ET-27311-00	D - 15		D - 6
5MV-22224-00	C - 14	5ET-23141-10	E - 6	5HD-23485-00	D - 2	5DH-25827-50	D - 12	5ET-27411-00	D - 15	90119-06225	C - 10
4JX-22226-00	C - 14	5ET-23141-20	E - 6	5MW-24110-00	D - 6	5DH-25828-50	D - 12	5ET-27421-00	D - 15	90122-06035	B - 8
3SP-22234-00	C - 14	5ET-23141-30	E - 6	4EW-2412F-00	D - 6	3SP-2583V-00	E - 2	4GY-27491-00	D - 12	90149-06011	D - 6
5DH-22253-00	C - 14	5ET-23141-40	E - 6	24X-24144-00	D - 6	5MV-25833-00	D - 14	5ET-28166-00	C - 9		E - 3
5MV-22253-00	C - 14	5DH-23142-L0	D - 3	3SP-24173-00	D - 6	3XP-25852-50	E - 2	5BE-82310-00	E - 5	90149-06326	B - 14
5ET-22355-00	C - 12			4SS-24181-00	D - 6	5MV-25852-00	D - 14	4PE-82370-10	E - 5	90149-06327	D - 9
3V6-22358-00	D - 6	5HD-23144-L0	D - 3	4SS-24182-00	D - 6	2VN-25854-00	E - 2	5HD-82911-00	E - 4	90151-04048	C - 12
4EW-22474-00	C - 14			3JD-24186-00	D - 6	56A-25854-00	D - 14	38V-82913-00	E - 4	90152-06010	C - 2
3JE-22475-00	C - 14	5ET-23145-L0	D - 3	5MV-24240-00	D - 6	2VN-25855-00	E - 2	5MV-83912-00	E - 4	90157-06077	B - 14
5MV-22475-00	C - 14			3XJ-24380-00	D - 6	2VN-25866-00	E - 2	5MV-83922-00	D - 14	90159-06016	C - 3
5DH-22898-50	D - 12	4SS-23146-L0	D - 3	3JD-24500-01	D - 6	5MV-25867-00	D - 14	5HD-83951-00	E - 4	90159-06078	C - 11
5MW-23102-00	D - 3			4X8-24512-00	D - 6	5G2-25868-00	D - 14	23X-83976-00	E - 4	90159-06182	C - 11
5MW-23102-10	D - 3	5DH-23149-L0	D - 3	3AJ-24534-00	D - 6	5ET-25872-00	D - 14	5HC-85540-00	E - 5	90170-20255	C - 3
5MW-23102-20	D - 3			5MV-24610-00	D - 6	5HD-25872-00	D - 14	5MW-85540-00	E - 5	90170-24373	D - 2
5MW-23103-00	D - 4	4SS-23153-L0	D - 3	4SS-24728-00	D - 7	5MV-25873-00	E - 2	5CU-85546-00	E - 5	90176-08026	B - 2
5MW-23103-10	D - 4			5MV-24731-00	D - 7	5DH-25875-00	D - 9	5CU-85550-10	E - 3	90179-06568	C - 12
5MW-23103-20	D - 4	4SS-23158-L0	D - 3	5MV-24770-00	D - 7	2VM-25876-00	E - 2	5CU-85560-00	E - 3	90179-08299	D - 11
5BF-23110-L0	D - 4			4DA-25104-00	D - 8	5MV-2589F-00	D - 14	5HC-85885-00	B - 12	90179-10394	E - 3
5MV-23111-L0	D - 3	5MV-2316A-L0	D - 3	4SS-25111-01	D - 8	4EW-25894-00	E - 2	9Y581-92113	D - 11	90179-16672	D - 8
				5DH-25117-00	D - 8	5DH-25916-00	D - 12	90101-06664	C - 8	90179-20255	C - 6
5DH-23118-L0	D - 4	5MV-2316A-M0	D - 3	5BE-25181-00	D - 8			90101-08777	D - 11	90179-28650	D - 2
				5DH-25183-00	D - 8	5DH-25919-00	D - 9	90105-05002	B - 4	90183-06023	B - 8
3JD-2312G-L0	D - 3	5MW-2316A-M0	D - 3	5BE-25186-00	D - 8	5DH-25919-50	D - 12	90105-06553	C - 7		C - 10
				5HD-25304-00	D - 10	8CR-25924-00	D - 12	90105-06556	B - 14	90183-06069	C - 11
5DH-23120-L0	D - 3	5MV-23170-L0	D - 3	5ET-25311-00	D - 10	5DH-25933-00	D - 9	90105-08099	C - 9	90185-08169	C - 9
5ET-23125-L0	D - 3			5ET-25317-00	D - 10	4XM-26111-00	D - 13	90105-08659	D - 9		D - 10
		5ET-23171-L0	D - 3	4XM-25364-00	D - 10	4XM-26240-00	D - 13	90105-10119	C - 9	90185-14112	C - 13
5HD-23136-L0	D - 3			5ET-25367-00	D - 11	4GY-26241-00	D - 13	90105-10323	C - 14	90185-16127	C - 12
		5DH-23183-00	C - 14	5ET-25381-00	D - 11	4GY-26242-00	D - 13	90105-10445	C - 3	90185-20168	D - 11
5DH-2314E-00	D - 9	509-23184-L0	C - 14	5ET-25383-00	D - 11	4SS-26256-00	D - 13	90105-105A2	C - 15	90201-03313	B - 8
5DH-2314F-L0	D - 5	5DH-23195-L0	D - 3	5ET-25388-00	D - 11	4SS-26259-00	D - 13	90109-05002	B - 2	90201-057H5	B - 2
4SS-2314G-L0	D - 5			5ET-25389-00	D - 11	4SS-26273-00	D - 13	90109-056G0	C - 3		B - 4
5DH-2314H-00	D - 5	5MV-23195-L0	D - 3	2J5-25394-01	D - 8	4SS-2628H-00	D - 13	90109-06027	E - 4	90201-06013	C - 7
5DH-2314J-00	D - 5			3JE-25394-00	D - 10	4SS-26281-00	D - 13	90109-063F8	C - 7	90201-06071	B - 13
4SR-23141-L0	D - 3	5HC-2331E-00	D - 5	5ET-25447-00	D - 10	4SS-26282-10	D - 13	90109-065G4	D - 12		C - 10
		5HC-23340-M0	D - 5	5ET-25448-00	D - 10	4SS-26287-01	D - 13	90109-081G1	D - 10	90201-06557	C - 10
4SS-23141-10	E - 6	4SS-23346-L0	D - 5	5ET-25449-00	D - 10	5HC-26311-00	D - 13	90109-142F4	C - 13	90201-080L8	B - 2
4SS-23141-20	E - 6	5MV-23346-L0	D - 5	5ET-25450-00	D - 10	4SS-2632G-00	D - 13	90109-147F2	C - 13	90201-08089	D - 15
4SS-23141-30	E - 6	3SP-23356-L0	D - 5	5ET-25451-00	D - 10	5HC-26335-10	D - 13	90110-08096	C - 9	90201-081G0	B - 3
4SS-23141-40	E - 6	4SS-23364-L0	E - 6	5ET-25452-00	D - 10	5HD-26337-00	E - 4	90116-08394	B - 2	90201-08326	D - 10
4SS-23141-50	E - 6	4DA-23389-00	D - 5	8CR-25715-00	D - 14	5HD-26342-00	D - 13	90116-10314	B - 2	90201-08512	B - 6
4SS-23141-60	E - 6	5HD-2339E-00	D - 2	5DH-25718-01	D - 12	5HD-26372-00	E - 4	90119-05071	D - 5	90201-086P8	C - 9

NUMERICAL INDEX

PARTNO.	GRID NO.	PARTNO.	GRID NO.	PARTNO.	GRID NO.	PARTNO.	GRID NO.	PARTNO.	GRID NO.	PARTNO.	GRID NO.
90201-087A9	C - 2	90387-16005	C - 12	90507-20052	B - 13	93210-22298	C - 5	94111-1913A	D - 10	95701-06500	D - 14
90201-08730	B - 13	90387-16007	C - 12	90508-155B8	B - 3	93210-74316	B - 2	94111-1916B	D - 10	95707-08500	C - 9
	C - 9	90387-167Y9	C - 12	90508-282B8	D - 15	93211-02703	B - 2	94111-1916C	D - 10	95707-10500	B - 2
90201-08784	B - 6	90387-1712Y	B - 14	90508-282B9	D - 15	93300-60801	B - 4	94209-21229	D - 8	95817-08050	C - 9
90201-10118	D - 14	90387-1714R	C - 12	90508-291A8	C - 8	93300-60804	C - 9	94211-19273	D - 10	95817-10050	C - 9
	E - 2	90387-1714S	C - 12	90508-305B0	C - 2	93306-00105	B - 6	94211-19274	D - 10	95817-10110	C - 9
90201-10119	D - 15	90387-2113G	C - 5	91A20-05065	B - 7	93306-00426	C - 5	94227-21101	D - 8	95827-06012	D - 9
90201-105P3	C - 3	90387-227H7	D - 13	91317-04006	B - 4	93306-00442	C - 5	94309-21161	D - 8	95827-06016	C - 11
90201-10591	E - 3	90387-2515B	C - 5	91317-04008	B - 3	93306-07202	D - 10	94311-19155	D - 10	97007-05016	E - 4
90201-112U6	C - 15	90401-10168	D - 14	91317-05008	C - 12	93306-20540	C - 5	94321-19157	D - 10	97007-05020	B - 3
90201-125L6	C - 3		E - 2	91317-06014	D - 14	93306-20574	C - 5	94330-21084	D - 8	97007-06012	C - 7
90201-12575	C - 8	90430-05242	C - 4	91317-06020	B - 8	93306-27205	D - 10	94416-21613	D - 8	97027-06016	D - 2
90201-14740	C - 13	90430-06014	B - 15	91317-06050	B - 14	93306-37808	B - 5	94421-19602	D - 10	97707-60016	C - 10
90201-150U6	B - 4		B - 6	91317-06060	B - 14	93306-90403	D - 8	94681-68001	D - 11	97780-50510	E - 2
90201-162H4	C - 2	90430-12227	B - 14	91317-06070	B - 14	93306-90501	C - 7	94702-00326	B - 2	97801-03008	D - 6
90201-164H4	C - 12	90445-08605	B - 14	91401-20012	D - 15	93306-90504	C - 7	94709-00326	B - 2	98502-04012	B - 11
	C - 13	90445-09104	D - 6	91401-25015	D - 15	93310-218A6	B - 5	95027-06010	B - 15	98502-04014	B - 10
90201-167P7	C - 2	90445-09220	D - 6	92014-06016	E - 2		E - 7		C - 12	98507-03008	B - 8
90201-20276	C - 2	90445-09270	B - 3	92017-06010	B - 13	93310-23077	C - 3	95027-06012	B - 13	98507-05012	B - 2
90201-203U1	D - 11	90445-116G8	D - 6	92907-03100	B - 8	93310-52406	B - 5		D - 12	98507-06030	B - 15
90201-20685	C - 2	90445-137H9	E - 2	92907-05600	B - 3		E - 7		E - 2	98507-06035	B - 15
90201-247L2	D - 2	90450-25037	B - 7	92907-06100	D - 7	93315-11206	C - 3	95027-06014	D - 2	98580-04006	B - 11
90201-253K0	C - 5	90450-28014	B - 7	92907-06600	B - 15	93315-32056	C - 12	95027-06016	D - 12	98706-04012	D - 14
90201-286K9	D - 2	90450-51070	B - 8	92907-08200	D - 9		C - 13		D - 6	98707-06025	D - 6
90202-05193	D - 6	90450-70072	B - 8	92907-10200	C - 9	93317-22262	C - 12		E - 5	98907-05012	B - 3
90209-06096	B - 8	90464-06214	B - 8	93102-12106	B - 6	93332-00068	D - 2	95027-06020	C - 8		B - 4
90209-21332	C - 5	90464-13073	E - 5	93102-12224	C - 3	93332-00081	D - 2	95027-06025	B - 13	98907-05016	B - 3
90209-24327	B - 5	90464-13077	E - 4		C - 8	93340-21505	B - 4		B - 15	98907-06020	D - 6
	E - 7	90464-15195	E - 5	93102-20484	C - 2		C - 3		B - 6	99001-06600	B - 6
90209-26348	C - 5	90464-50255	E - 5	93102-20485	B - 5	93342-22217	C - 12		D - 13	99009-16400	C - 2
90215-20231	C - 3	90465-13275	D - 6	93102-26468	D - 8	93410-20038	C - 2	95027-06030	B - 15	99009-20400	C - 2
90215-21256	C - 6	90465-16258	D - 14	93102-28004	B - 5	93440-10085	C - 3		C - 10	99009-45500	D - 10
90240-08120	D - 15	90467-09006	B - 7	93102-32337	C - 5	93440-25084	C - 5	95027-06050	B - 15	99244-00200	C - 13
90240-10142	D - 15	90467-10008	D - 6	93104-08040	B - 3	93440-28062	C - 5		C - 12	99530-08016	B - 15
90267-32070	B - 8	90467-12053	E - 2		B - 4	93450-19052	B - 5	95027-06065	B - 15	99530-14016	B - 2
90280-03017	B - 5	90468-16191	D - 15	93106-22019	C - 12		E - 7		B - 6		
90338-16148	C - 12	90480-08608	D - 11	93106-30044	D - 10	93501-04011	C - 2	95027-08012	B - 13		
	C - 9	90480-15528	B - 7	93106-30045	D - 10	93507-16020	B - 4	95027-08020	C - 2		
90340-12059	B - 14	90480-16561	B - 13	93109-11073	B - 6	93603-14240	B - 4		D - 9		
90387-06009	C - 10	90480-18549	D - 6	93109-20076	C - 12	93604-08071	B - 2	95027-08035	D - 2		
	C - 11	90501-046L6	B - 3		C - 13	93604-10011	B - 6	95027-08040	C - 9		
90387-0614M	B - 7	90501-052G5	C - 8	93109-28043	C - 12	93604-29184	B - 4		D - 2		
90387-063G3	B - 13	90501-13720	C - 2	93210-06001	D - 13	93612-16254	B - 14	95027-08065	C - 9		
90387-0701A	C - 10	90501-16016	C - 2	93210-11073	D - 15	9383E-13144	C - 6	95607-05100	B - 8		
90387-085E1	B - 4	90501-23141	C - 3	93210-15620	E - 2	9383E-14215	C - 6	95607-06100	E - 4		
90387-086N4	C - 9	90501-256L2	B - 4	93210-15639	B - 2	94108-21011	D - 8	95607-10200	C - 15		
90387-124F4	C - 8	90506-16500	D - 15	93210-19123	B - 15	94108-2110Y	D - 8		C - 9		
90387-152F2	B - 4	90507-14064	C - 7	93210-19216	C - 2	94108-2112Y	D - 8	95617-10660	B - 2		

CONTENTS

ENGINE

CYLINDER HEAD	B2
GOVERNOR	B4
CRANKSHAFT. PISTON	B5
WATER PUMP	B6
RADIATOR. HOSE	B7
INTAKE	B8
CARBURETOR	B9
EXHAUST	B13
CRANKCASE	B14
CRANKCASE COVER 1	B15
STARTER	C2
CLUTCH	C3
TRANSMISSION	C5
SHIFT CAM. FORK	C7
SHIFT SHAFT	C8

CHASSIS

FRAME	C9
FENDER	C10
SIDE COVER	C11
REAR ARM	C12
REAR SUSPENSION	C14
STEERING	D2
FRONT FORK	D3
FUEL TANK	D6
SEAT	D7
FRONT WHEEL	D8
FRONT BRAKE CALIPER	D9
REAR WHEEL	D10

REAR BRAKE CALIPER	D12
STEERING HANDLE. CABLE	D13
FRONT MASTER CYLINDER	D14
STAND. FOOTREST	D15
REAR MASTER CYLINDER	E2
GENERATOR	E3
HANDLE SWITCH. LEVER	E4
ELECTRICAL 1	E5
ALTERNATE (CHASSIS)	E6
OPTIONAL PARTS 1	E7

INDEX

NUMERICAL INDEX	M1
-----------------------	----