



PARTS CATALOGUE

YZ250T1 (1P81) CANADA,U.S.A.,SOUTH AFRICA

YZ250 (1P82) EUROPE

YZ250 (1P83) JAPAN

YZ250T1 (1P84) OCEANIA

YZ250T1/YZ250
PARTS CATALOGUE
©2004 by Yamaha Motor Co., Ltd.
1st edition, June 2004
All rights reserved.
Any reprinting or unauthorized use
without the written permission of
Yamaha Motor Co., Ltd.
is expressly prohibited.
Printed in Japan.

A3



A4

FOREWORD

This Parts Catalogue is related to the parts for the model(s) on the cover page. When you are ordering replacement parts, please refer to this Parts Catalogue and quote both part numbers and part names correctly.

1. Modifications or additions which have been made after the issue of the Parts Catalogue will be announced in the Parts News.

It is advisable that you make the necessary corrections to the Parts Catalogue according to the Parts News.

2. Abbreviations

The following abbreviations are used in this Parts Catalogue.

“UR” Use specified parts number.

“UN” Use as many as needed.

“AP” Alternate Parts

“LM” Locally Made (Parts need to be ordered locally)

“F#” Frame No. (Applicable machine No.)

“O/S” Over Size

3. The number of components for assembly

- Parts, which are to be supplied in an assembly, are listed with a dot (.) in front of the part name as shown below.
- The numeral appearing to the right of each component part indicates the quantity of parts for each assembly unit.

PART NO.	DESCRIPTION	Q'TY	REMARKS
2F5-83310-60	FRONT FLASHER LIGHT ASSY	2	
115-83311-60	.BULB (6V-18W)	1	

4. Applicable colours of graphics are represented in the “REMARKS” as shown below.

PART NO.	DESCRIPTION	Q'TY	REMARKS
2N4-24110-00-X5	FUEL TANK COMP.	2	MXR
3J1-24240-10	.GRAPHIC, FUEL TANK	1	FOR MXR

5. Note that the illustrations for reference in finding parts numbers are not to be used for assembling. When assembling, please use the applicable service manual.

6. The asterisk (*) before a reference number indicates modified items after the first edition.

FOREWORD

7. Applicable Serial No.

Engine Serial No.

Frame Serial No.

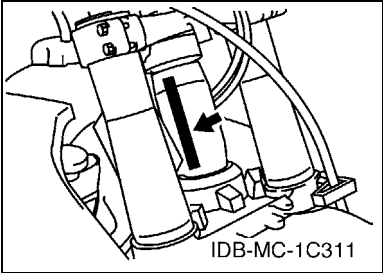
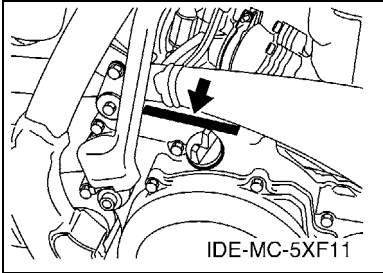

8. Applicable Colour Code (The (*) mark shows Model colour.)

Abbreviation	Colour Name	Colour Code
DPBSE(*)	DEEP PURPLISH BLUE SOLID E	0583

CONTENTS

ENGINE

CYLINDER HEAD	B2
GOVERNOR	B4
CRANKSHAFT & PISTON	B5
WATER PUMP	B6
RADIATOR & HOSE	B7
INTAKE	B8
CARBURETOR	B9
EXHAUST	B12
CRANKCASE	B13
CRANKCASE COVER 1	B14
STARTER	B15
CLUTCH	C2
TRANSMISSION	C4
SHIFT CAM & FORK	C6
SHIFT SHAFT	C7

CHASSIS

FRAME	C8
FENDER	C10
SIDE COVER	C11
REAR ARM	C12
REAR SUSPENSION	C14
STEERING	D2
FRONT FORK	D3
FUEL TANK	D6
SEAT	D8
FRONT WHEEL	D9
FRONT BRAKE CALIPER	D10
REAR WHEEL	D11
REAR BRAKE CALIPER	D13
STEERING HANDLE & CABLE	D14
FRONT MASTER CYLINDER	D15
STAND & FOOTREST	E2
REAR MASTER CYLINDER	E3
GENERATOR	E4
HANDLE SWITCH & LEVER	E5
ELECTRICAL 1	E6
ALTERNATE FOR CHASSIS	E7
OPTIONAL PARTS 1	E8

INDEX

NUMERICAL INDEX	M1
-----------------------	----

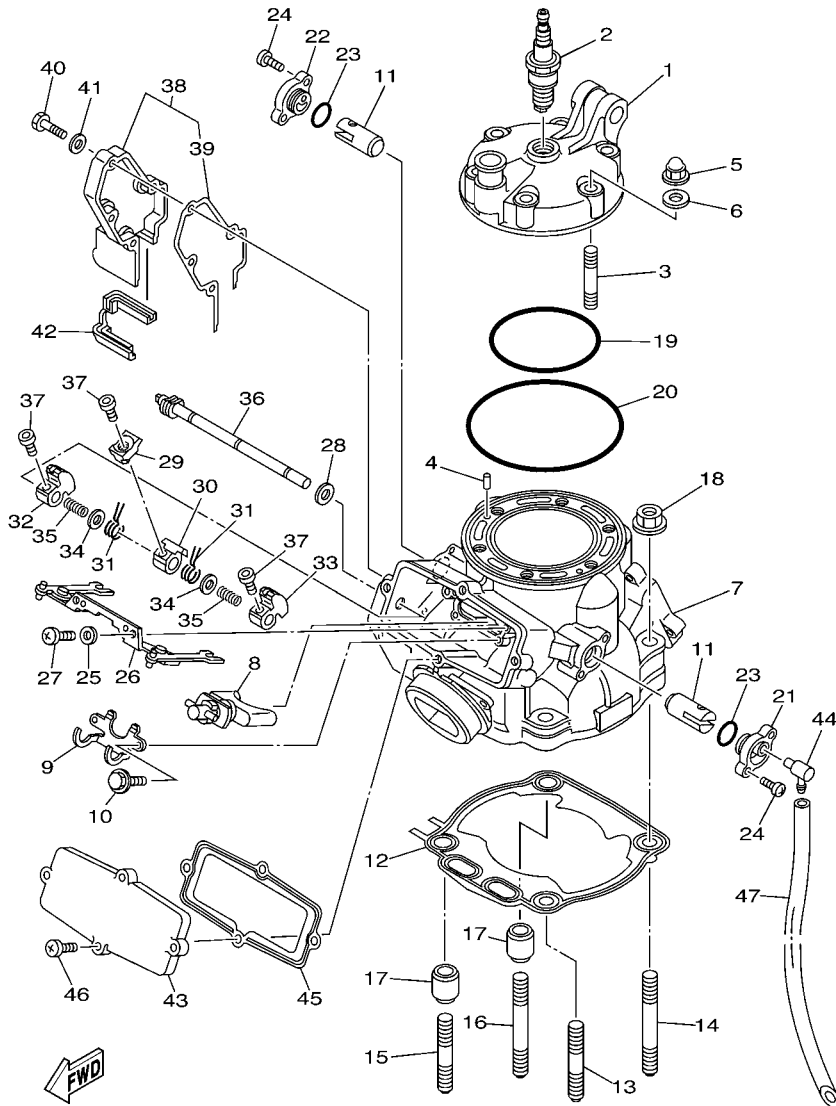

5NX1100-A010

FIG. 1 CYLINDER HEAD

REF. NO.	PART NO.	DESCRIPTION	1P81	1P82	1P83	1P84	REMARKS
1	5UP-11111-00	HEAD, CYLINDER 1	1			1	
	5MW-11111-01	HEAD, CYLINDER 1		1	1		
2	94702-00326	PLUG, SPARK (NGK BR8EG)	1	1		1	
	94709-00326	PLUG, SPARK (NGK BR8EG)			1		
3	90116-08394	BOLT, STUD	6	6	6	6	
4	93604-08071	PIN, DOWEL	2	2	2	2	
5	90176-08026	NUT, CROWN	6	6	6	6	
6	90201-080L8	WASHER, PLATE	6	6	6	6	
7	5UP-11311-00	CYLINDER 1	1	1	1	1	
8	5XF-1131D-00	VALVE ASSY	1	1	1	1	
9	5CU-1131U-10	HOLDER 3	1	1	1	1	
10	90109-05001	BOLT	2	2	2	2	
11	5CU-1132A-00	VALVE 2	2	2	2	2	
12	5UP-11351-00	GASKET, CYLINDER	1	1	1	1	
13	90116-10314	BOLT, STUD	1	1	1	1	
14	95617-10660	BOLT, STUD	1	1	1	1	
15	90116-10314	BOLT, STUD	1	1	1	1	
16	95617-10660	BOLT, STUD	1	1	1	1	
17	99590-14016	PIN, DOWEL	2	2	2	2	
18	90179-10M35	NUT	4	4	4	4	
19	93210-74316	O-RING	1	1	1	1	
20	93211-02703	O-RING	1	1	1	1	
21	5CU-1131E-00	HOLDER 1	1	1	1	1	
22	5CU-1131P-00	HOLDER 4	1	1	1	1	
23	93210-15639	O-RING	2	2	2	2	
24	98507-05012	SCREW, PAN HEAD	4	4	4	4	
25	90201-057H5	WASHER, PLATE	2	2	2	2	

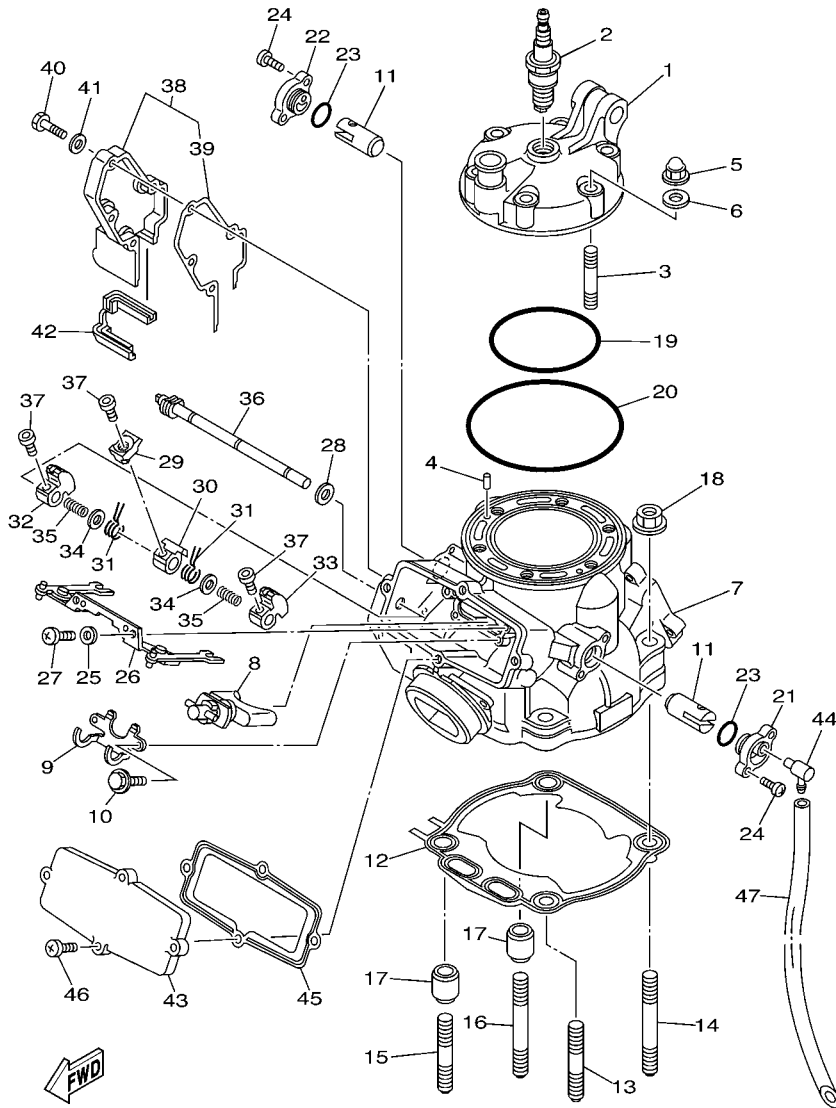

5NX1100-A010

FIG. 1 CYLINDER HEAD

REF. NO.	PART NO.	DESCRIPTION	1P81	1P82	1P83	1P84	REMARKS
26	5CU-11830-00	LINK ASSY	1	1	1	1	
27	98907-05012	SCREW, BIND	2	2	2	2	
28	93104-08040	OIL SEAL	1	1	1	1	
29	5NX-11395-00	HOLDER	1	1	1	1	
30	4SS-11832-00	LEVER, LINK	1	1	1	1	
31	90508-155B8	SPRING, TORSION	2	2	2	2	
32	5MW-1132E-00	PULLEY 1	1	1	1	1	
33	5MW-1132F-00	PULLEY 2	1	1	1	1	
34	90201-081G0	WASHER, PLATE	2	2	2	2	
35	90501-046L6	SPRING, COMPRESSION	2	2	2	2	
36	5CU-1131V-00	SHAFT 1	1	1	1	1	
37	91317-04008	BOLT	3	3	3	3	
38	5CU-11991-00	HOUSING 1	1	1	1	1	
39	5CU-11993-00	.GASKET	1	1	1	1	
40	97007-05020	BOLT	4	4	4	4	
41	92907-05600	WASHER, PLATE	4	4	4	4	
42	5CU-11995-00	SEAL, HOUSING	1	1	1	1	
43	5CU-1131M-00	COVER	1	1	1	1	
44	353-13115-01	CONNECTOR, SUCTION PIPE	1	1	1	1	
45	5CU-11354-00	GASKET	1	1	1	1	
46	98907-05016	SCREW, BIND	4	4	4	4	
47	90445-09777	HOSE (L300)	1	1	1	1	

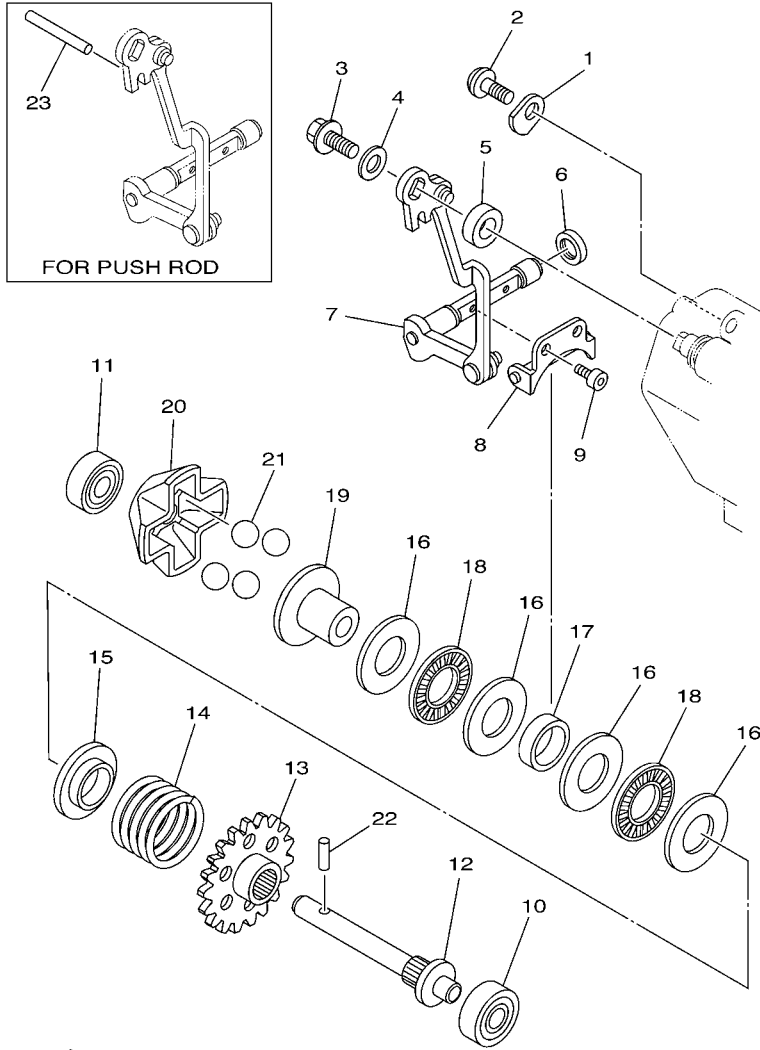

5NX1100-A020

FIG. 2 GOVERNOR

REF. NO.	PART NO.	DESCRIPTION	1P81	1P82	1P83	1P84	REMARKS
1	4JY-11915-01	PLATE, THRUST 1	1	1	1	1	
2	98907-05012	SCREW, BIND	1	1	1	1	
3	90105-05002	BOLT, FLANGE	1	1	1	1	
4	90201-057H5	WASHER, PLATE	1	1	1	1	
5	90387-085E1	COLLAR	1	1	1	1	
6	93104-08040	OIL SEAL	1	1	1	1	
7	5CU-11990-00	PUSH ROD ASSY	1	1	1	1	
8	3JE-11922-01	FORK, GOVERNOR	1	1	1	1	
9	91317-04006	BOLT	2	2	2	2	
10	93300-60801	BEARING (B0060)	1	1	1	1	KOYO
11	93300-60801	BEARING (B0060)	1	1	1	1	KOYO
12	5X4-11921-02	SHAFT, GOVERNOR	1	1	1	1	
13	5NY-11953-00	GEAR, GOVERNOR	1	1	1	1	
14	90501-256L2	SPRING, COMPRESSION	1	1	1	1	
15	5CU-11952-00	PLATE	1	1	1	1	
16	90201-150U6	WASHER, PLATE	4	4	4	4	
17	90387-152F2	COLLAR	1	1	1	1	
18	93340-21505	BEARING	2	2	2	2	
19	5CU-11912-00	RETAINER, WEIGHT	1	1	1	1	
20	5CU-11911-00	RETAINER	1	1	1	1	
21	93507-16020	BALL	4	4	4	4	
22	93603-14240	PIN, DOWEL	1	1	1	1	
23	93604-29184	PIN, DOWEL	1	1	1	1	AP

FIG. 3 CRANKSHAFT & PISTON

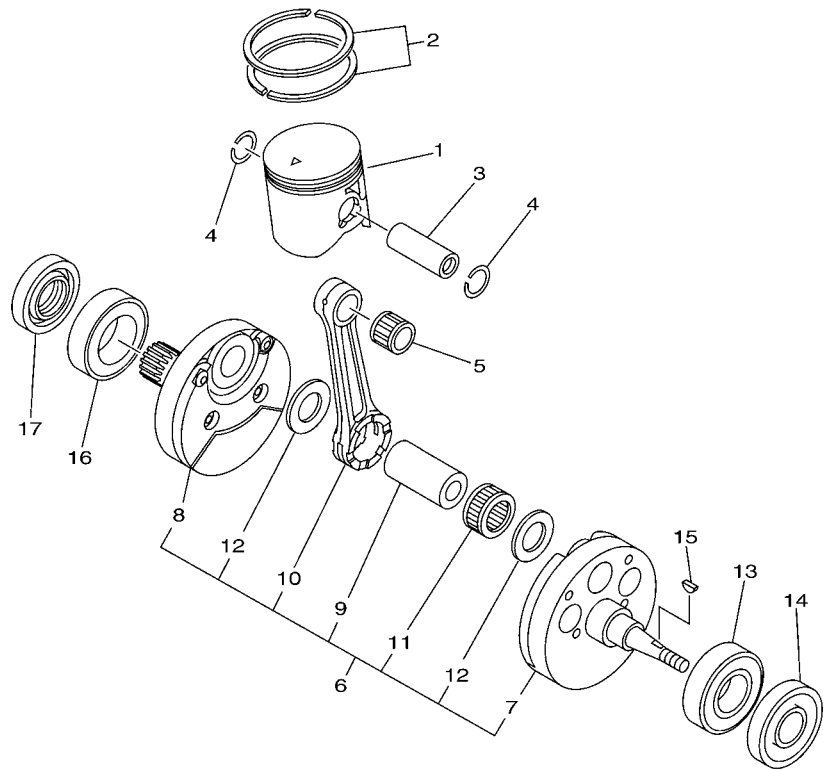

REF. NO.	PART NO.	DESCRIPTION	1P81	1P82	1P83	1P84	REMARKS
1	1P8-11631-00-A0	PISTON (STD)	1	1	1	1	UR RED
	1P8-11631-00-B0	PISTON (STD)	1	1	1	1	UR ORANGE
	1P8-11631-00-C0	PISTON (STD)	1	1	1	1	UR GREEN
	1P8-11631-00-D0	PISTON (STD)	1	1	1	1	UR PURPLE
2	5CU-11603-10	PISTON RING SET (STD)	1	1	1	1	
3	5UP-11633-00	PIN, PISTON	1	1	1	1	
4	93450-19052	CIRCLIP	2	2	2	2	
5	93310-218A6	BEARING	1	1	1	1	
6	5UP-11400-00	CRANKSHAFT ASSY	1	1	1	1	
7	5UP-11410-00	.CRANKSHAFT	1	1	1	1	
8	5MW-11420-00	.CRANKSHAFT	1	1	1	1	
9	5CU-11681-00	.PIN, CRANK 1	1	1	1	1	
10	5MW-11651-00	.ROD, CONNECTING	1	1	1	1	
11	93310-52406	.BEARING	1	1	1	1	
12	90209-24327	.WASHER	2	2	2	2	
13	93306-37808	BEARING	1	1	1	1	
14	93102-20485	OIL SEAL	1	1	1	1	
15	90280-03017	KEY, WOODRUFF	1	1	1	1	
16	93306-37808	BEARING	1	1	1	1	
17	93102-28004	OIL SEAL	1	1	1	1	



5MW1100-1030

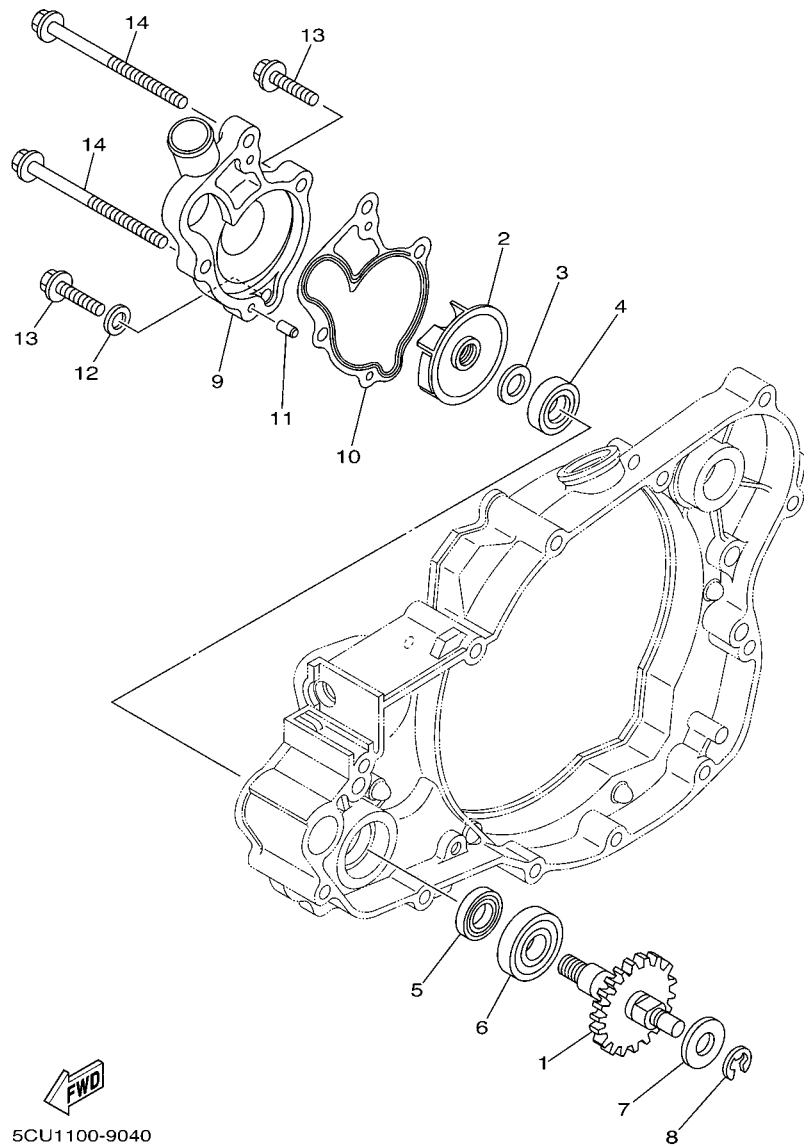

5CU1100-9040

FIG. 4 WATER PUMP

REF. NO.	PART NO.	DESCRIPTION	1P81	1P82	1P83	1P84	REMARKS
1	5CU-12459-00	GEAR, IMPELLER SHAFT	1	1	1	1	
2	5DJ-12451-00	IMPELLER, WATER PUMP	1	1	1	1	
3	90201-08512	WASHER, PLATE	1	1	1	1	
4	93109-11073	OIL SEAL	1	1	1	1	
5	93102-12106	OIL SEAL (SD 12-22-5 HS)	1	1	1	1	
6	93306-00105	BEARING (B6001)	1	1	1	1	
7	90201-08784	WASHER, PLATE	1	1	1	1	
8	99001-06600	CIRCLIP	1	1	1	1	
9	5MW-12422-00	COVER, HOUSING	1	1	1	1	
10	5XF-12428-00	GASKET, HOUSING COVER 2	1	1	1	1	
11	93604-10011	PIN, DOWEL	2	2	2	2	
12	90430-06014	GASKET	1	1	1	1	
13	95027-06025	BOLT, FLANGE	2	2	2	2	
14	95027-06065	BOLT, FLANGE	2	2	2	2	

B6

FIG. 5 RADIATOR & HOSE

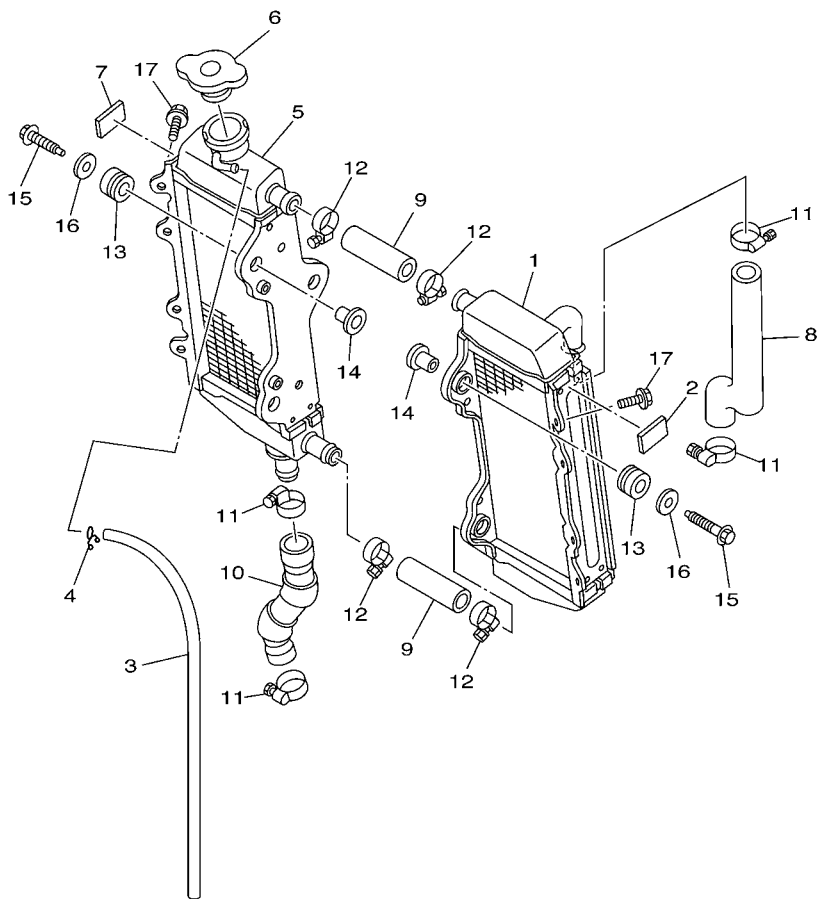

FWD
1P81100-D050

REF. NO.	PART NO.	DESCRIPTION	1P81	1P82	1P83	1P84	REMARKS
1	5NX-1240A-00	RADIATOR ASSY	1	1	1	1	
2	1C3-12465-00	DAMPER, RADIATOR	1	1	1	1	
3	91A20-05065	TUBE, FLEXIBLE VINYL	1	1	1	1	
4	90467-09006	CLIP	1	1	1	1	
5	5NX-12461-00	RADIATOR ASSY	1	1	1	1	
6	5HD-12462-00	CAP, RADIATOR	1	1	1	1	
7	1C3-12465-00	DAMPER, RADIATOR	1	1	1	1	
8	5CU-12481-10	PIPE 1	1	1	1	1	
9	5NY-12482-00	PIPE 2	2	2	2	2	
10	1P8-12484-00	PIPE 4	1	1	1	1	
11	90450-28014	HOSE CLAMP ASSY	4	4	4	4	
12	90450-25037	HOSE CLAMP ASSY	4	4	4	4	
13	90480-15528	GROMMET	6	6	6	6	
14	90387-06065	COLLAR	6	6	6	6	
15	95027-06025	BOLT, FLANGE	6	6	6	6	
16	90201-06571	WASHER, PLATE	6	6	6	6	
17	95827-06010	BOLT, FLANGE	2	2	2	2	

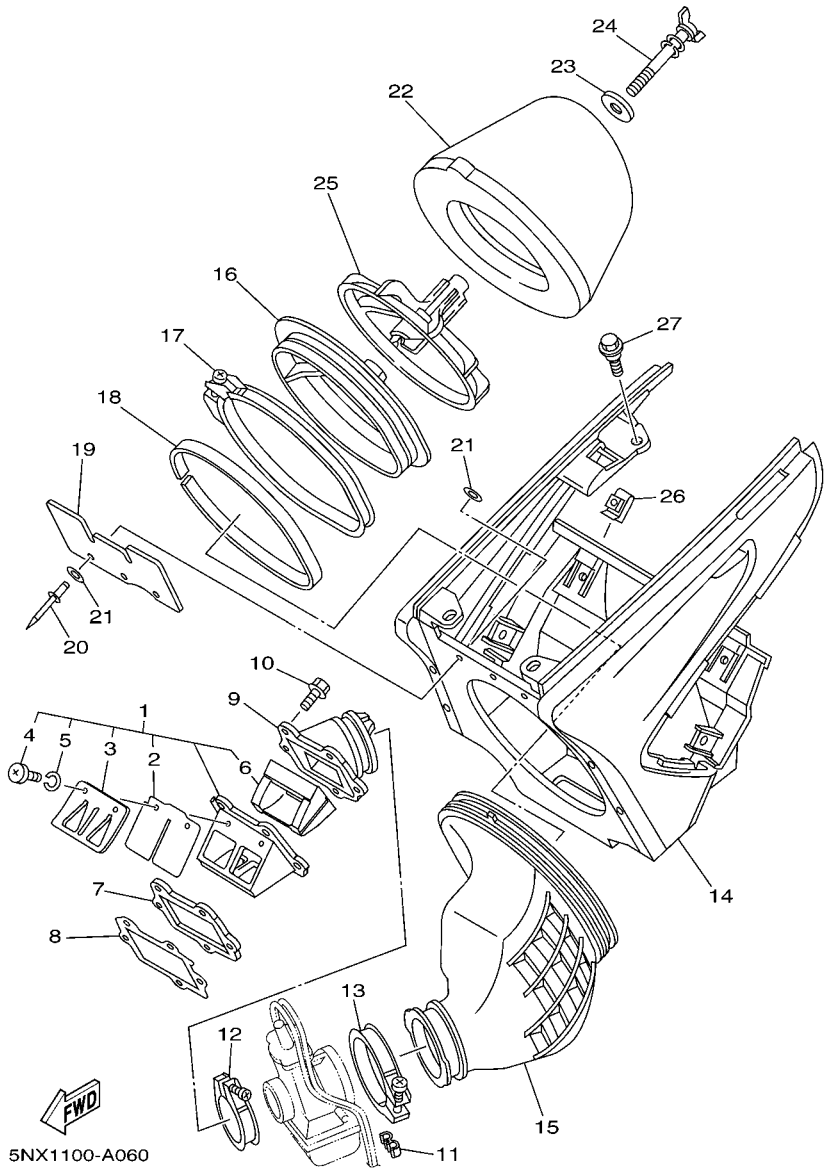

FIG. 6 INTAKE

REF. NO.	PART NO.	DESCRIPTION	1P81	1P82	1P83	1P84	REMARKS
1	5NX-13610-00	REED VALVE ASSY	1	1	1	1	
2	5NX-13613-00	.REED, VALVE	2	2	2	2	
3	4XL-13616-00	.STOPPER, REED VALVE	2	2	2	2	
4	98507-03008	.SCREW, PAN HEAD	4	4	4	4	
5	92907-03100	.WASHER, SPRING	4	4	4	4	
6	4XL-13625-00	.SPACER, REED VALVE	1	1	1	1	
7	5NX-13624-00	PLATE, REED VALVE	1	1	1	1	
8	5XF-13622-00	GASKET, VALVE SEAT	1	1	1	1	
9	5NX-13565-00	JOINT, CARBURETOR	1	1	1	1	
10	91317-06025	BOLT	5	5	5	5	
11	90464-06214	CLAMP	2	2	2	2	
12	90450-51070	HOSE CLAMP ASSY	1	1	1	1	
13	90450-70072	HOSE CLAMP ASSY	1	1	1	1	
14	5NY-14401-01	AIR CLEANER CASE ASSY	1	1	1	1	
15	5NX-14453-00	JOINT, AIR CLEANER 1	1	1	1	1	
16	5NY-14459-00	HOLDER, GUIDE	1	1	1	1	
17	5NY-14455-10	BAND	1	1	1	1	
18	5NY-14442-00	SPACER	1	1	1	1	
19	5NY-14417-00	COVER 1	1	1	1	1	
20	90267-32070	RIVET, BLIND	3	3	3	3	
21	90201-03313	WASHER, PLATE	6	6	6	6	
22	4XM-14451-00	ELEMENT, AIR CLEANER	1	1	1	1	
23	90209-06096	WASHER	1	1	1	1	
24	90122-06035	BOLT, WING	1	1	1	1	
25	3JD-14458-01	GUIDE	1	1	1	1	
26	90183-06023	NUT, SPRING	4	4	4	4	
27	90109-067F4	BOLT	4	4	4	4	

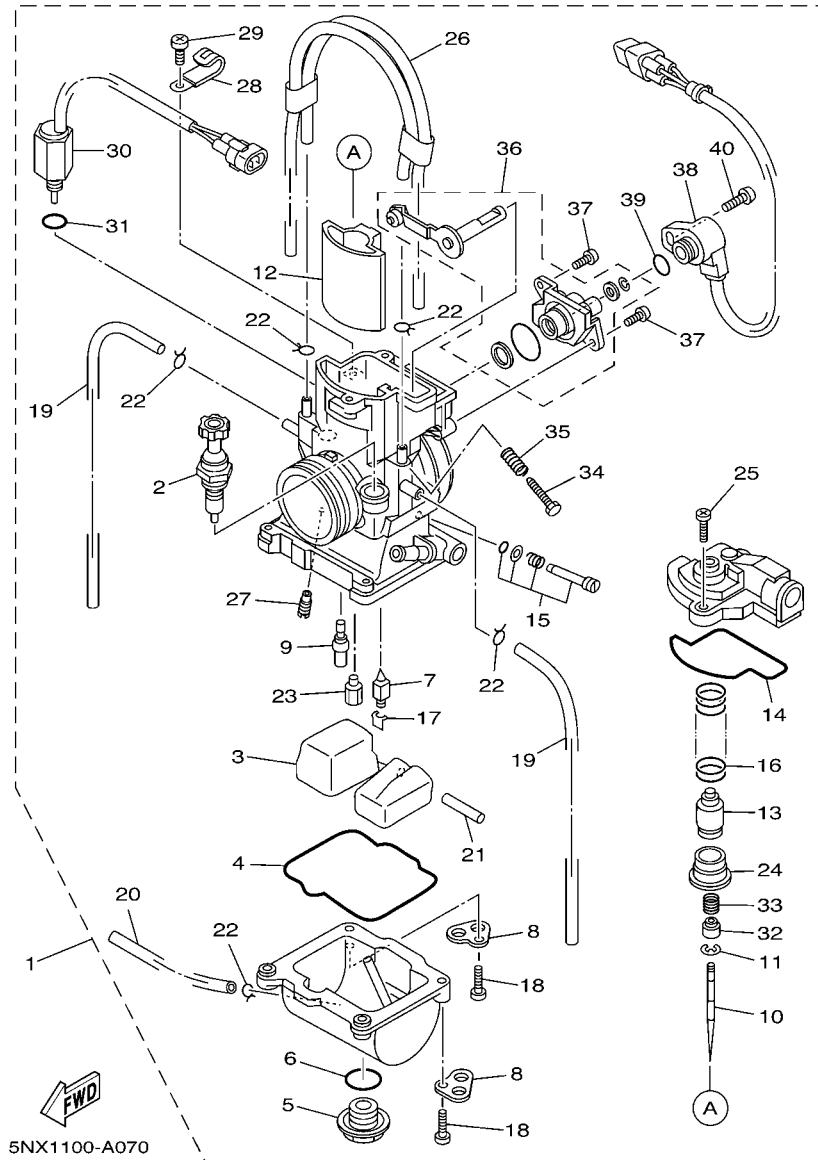
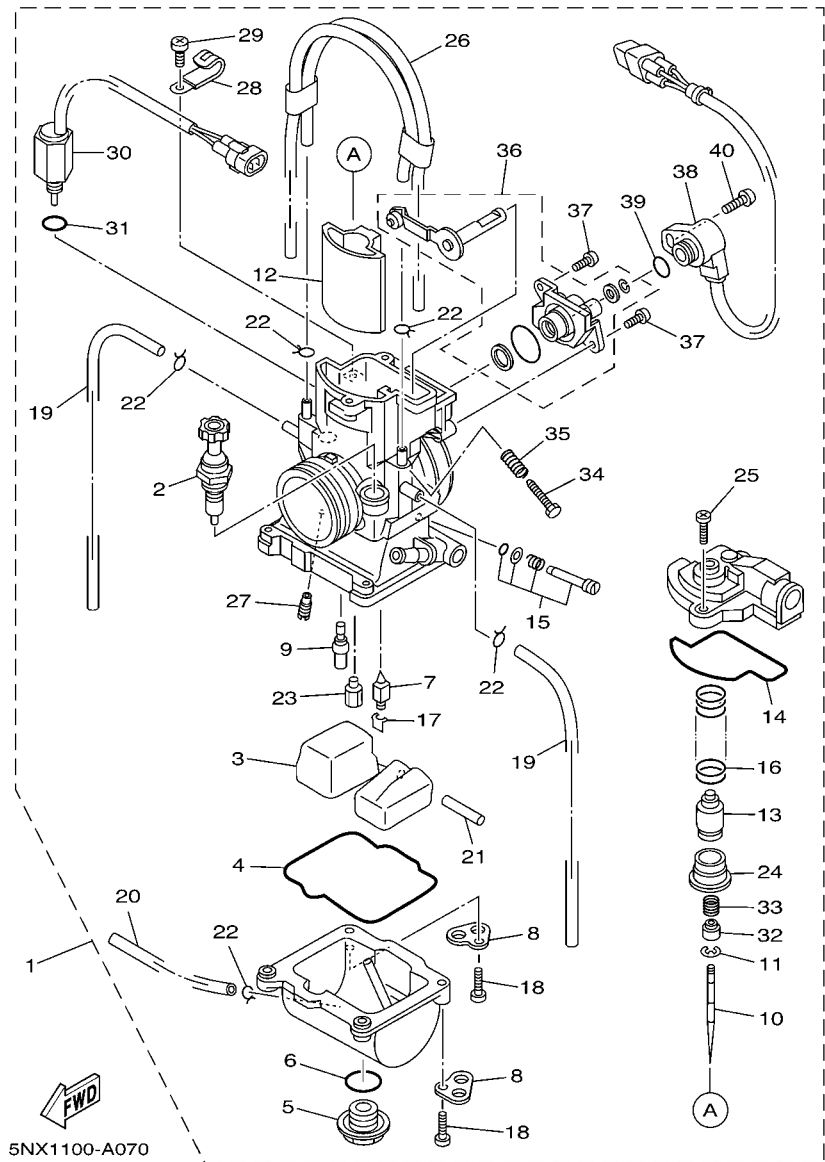

FIG. 7 CARBURETOR

REF. NO.	PART NO.	DESCRIPTION	1P81	1P82	1P83	1P84	REMARKS
1	1P8-14101-00	CARBURETOR ASSY 1	1			1	
	1P8-14101-10	CARBURETOR ASSY 1		1			
	1P8-14101-20	CARBURETOR ASSY 1			1		
2	4JT-14171-00	.PLUNGER, STARTER	1	1	1	1	
3	4SR-14985-00	.FLOAT	1	1	1	1	
4	4JT-14984-00	.GASKET, FLOAT CHAMBER	1	1	1	1	
5	4MX-14115-00	.PLUG, SCREW	1	1	1	1	
6	4MX-14561-00	.O-RING	1	1	1	1	
7	4MX-14392-00	.VALVE, NEEDLE	1	1	1	1	
8	4XL-14146-00	.PLATE	2	2	2	2	
9	4MX-14948-07	.JET, SLOW (#50)	1		1	1	STD
	4MX-14948-08	.JET, SLOW (#52)		1			STD
	4MX-14948-02	.JET, SLOW (#38)	1	1	1	1	AP
	4MX-14948-03	.JET, SLOW (#40)	1	1	1	1	AP
	4MX-14948-04	.JET, SLOW (#42)	1	1	1	1	AP
	4MX-14948-05	.JET, SLOW (#45)	1	1	1	1	AP
	4MX-14948-06	.JET, SLOW (#48)	1	1	1	1	AP
	4MX-14948-07	.JET, SLOW (#50)		1			AP
	4MX-14948-08	.JET, SLOW (#52)	1		1	1	AP
	4MX-14948-09	.JET, SLOW (#55)	1	1	1	1	AP
	4MX-14948-10	.JET, SLOW (#58)	1	1	1	1	AP
	4MX-14948-11	.JET, SLOW (#60)	1	1	1	1	AP
	4MX-14948-12	.JET, SLOW (#62)	1	1	1	1	AP
10	4SR-14916-EJ	.NEEDLE (N3EJ)	1			1	STD
	4SR-14916-EW	.NEEDLE (N3EW)		1	1		STD
	4SR-14916-CK	.NEEDLE (N3CK)	1			1	AP
	4SR-14916-EK	.NEEDLE (N3EK)	1			1	AP



5NX1100-A070

FIG. 7 CARBURETOR

REF. NO.	PART NO.	DESCRIPTION	1P81	1P82	1P83	1P84	REMARKS
10	4SR-14916-CJ	.NEEDLE (N3CJ)	1	1	1	1	AP
	4SR-14916-EJ	.NEEDLE (N3EJ)		1	1		AP
	4SR-14916-RJ	.NEEDLE (N8RJ)	1	1	1	1	AP
	4SR-14916-EW	.NEEDLE (N3EW)	1			1	AP
	4SR-14916-RW	.NEEDLE (N8RW)	1	1	1	1	AP
	4SR-14916-EH	.NEEDLE (N3EH)		1	1		AP
	4SR-14916-RH	.NEEDLE (N8RH)		1	1		AP
11	4MX-14919-00	.CLIP	1	1	1	1	
12	5HC-14340-A7	.VALVE ASSY	1	1	1	1	
13	5HC-14261-00	.HOLDER	1	1	1	1	
14	5HC-14126-00	.GASKET	1	1	1	1	
15	4SR-14105-00	.PILOT SCREW SET	1	1	1	1	
16	5HC-14131-00	.SPRING, THROTTLE VALVE	1	1	1	1	
17	663-14159-00	.CLIP	1	1	1	1	
18	98502-04014	.SCREW, PAN HEAD	4	4	4	4	
19	4XL-14197-10	.PIPE	2	2	2	2	
20	4XL-14196-10	.PIPE	1	1	1	1	
21	676-14548-00	.PIN, FLOAT ARM	1	1	1	1	
22	3TJ-14137-40	.CLIP	5	5	5	5	
23	4MX-14943-93	.JET, MAIN (#178)	1		1	1	STD
	4MX-14943-43	.JET, MAIN (#180)		1			STD
	4MX-14943-90	.JET, MAIN (#162)	1	1	1	1	AP
	4MX-14943-40	.JET, MAIN (#165)	1	1	1	1	AP
	4MX-14943-91	.JET, MAIN (#168)	1	1	1	1	AP
	4MX-14943-41	.JET, MAIN (#170)	1	1	1	1	AP
	4MX-14943-92	.JET, MAIN (#172)	1	1	1	1	AP
	4MX-14943-42	.JET, MAIN (#175)	1	1	1	1	AP

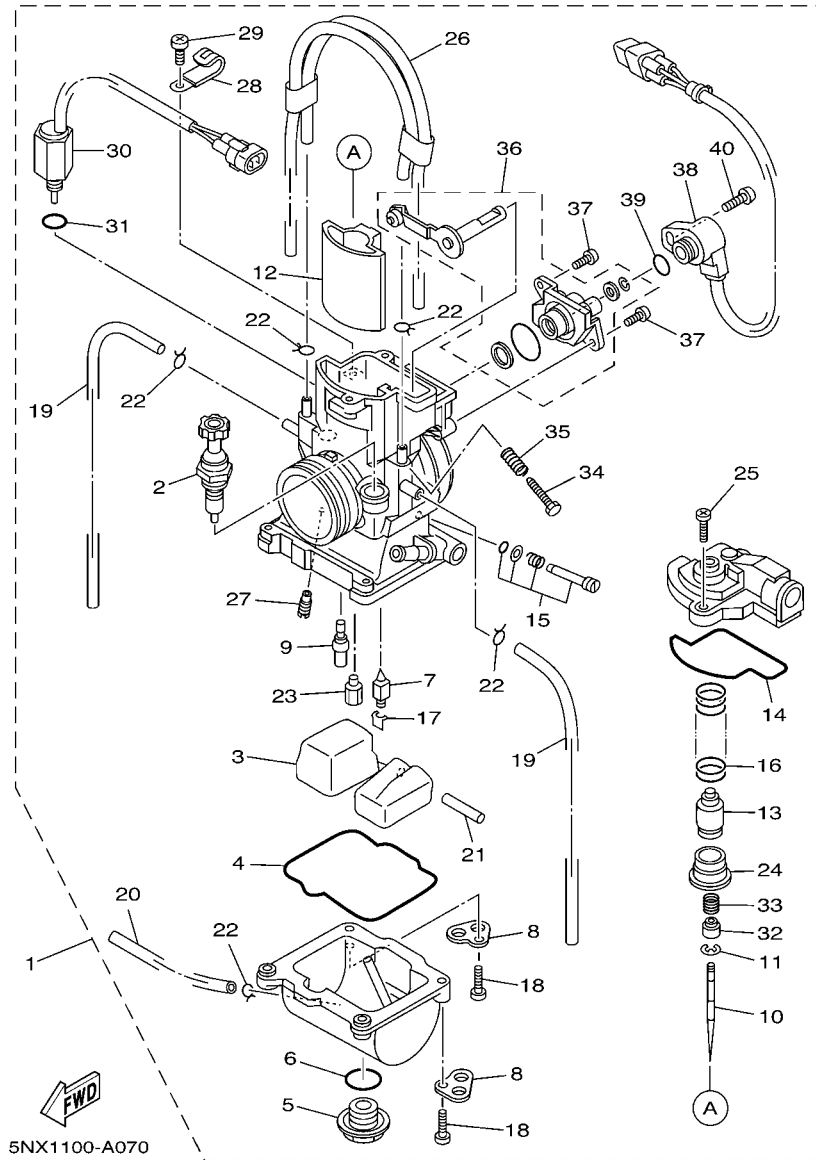

5NX1100-A070

FIG. 7 CARBURETOR

REF. NO.	PART NO.	DESCRIPTION	1P81	1P82	1P83	1P84	REMARKS
23	4MX-14943-93	.JET, MAIN (#178)		1			AP
	4MX-14943-43	.JET, MAIN (#180)	1	1	1		AP
	4MX-14943-94	.JET, MAIN (#182)	1	1	1	1	AP
	4MX-14943-44	.JET, MAIN (#185)	1	1	1	1	AP
	4MX-14943-95	.JET, MAIN (#188)	1	1	1	1	AP
	4MX-14943-45	.JET, MAIN (#190)	1	1	1	1	AP
24	4MX-14194-00	.RING	1	1	1	1	
25	98502-04012	.SCREW, PAN HEAD	2	2	2	2	
26	4XL-1410E-00	.HOSE	1	1	1	1	
27	4JT-1494F-07	.JET (#50)	1	1	1	1	STD
	4JT-1494F-03	.JET (#40)	1	1	1	1	AP
	4JT-1494F-09	.JET (#55)	1	1	1	1	AP
	4JT-1494F-11	.JET (#60)	1	1	1	1	AP
	4JT-1494F-13	.JET (#65)	1	1	1	1	AP
28	5HC-14146-00	.PLATE	1	1	1	1	
29	98580-04006	.SCREW, PAN HEAD	1	1	1	1	
30	5NX-1410H-00	.FUEL CUT SOLENOID VALVE	1	1	1	1	
31	4JT-14147-00	.O-RING	1	1	1	1	
32	5HC-14264-00	.COLLAR	1	1	1	1	
33	5HC-14275-00	.SPRING	1	1	1	1	
34	5HC-14922-00	.SCREW, THROTTLE	1	1	1	1	
35	5HC-14934-00	.SPRING, THROTTLE STOP	1	1	1	1	
36	1P8-14208-00	.LEVER COMP. 1	1	1	1	1	
37	5HC-14216-00	.SCREW	2	2	2	2	
38	5NX-85885-00	.THROTTLE SENSOR ASSY	1	1	1	1	
39	5NX-14562-00	.O-RING	1	1	1	1	
40	5NX-14216-00	.SCREW	1	1	1	1	

FIG. 8 EXHAUST

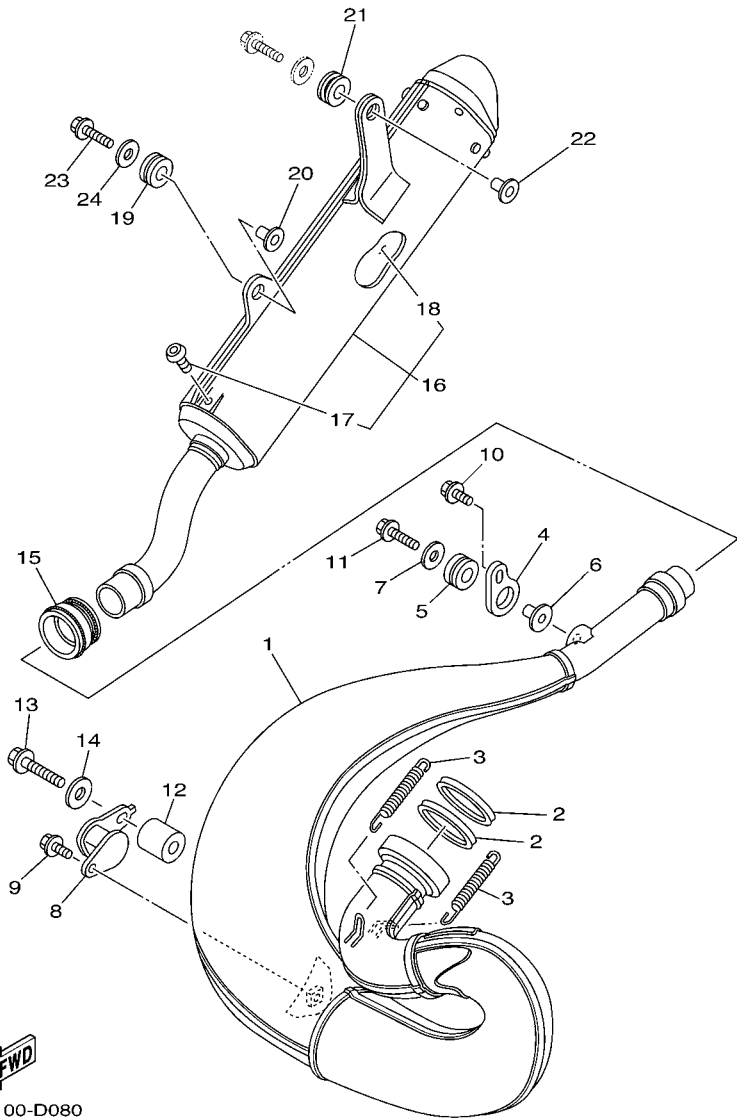

1P81100-D080

REF. NO.	PART NO.	DESCRIPTION	1P81	1P82	1P83	1P84	REMARKS
1	1P8-14610-00	EXHAUST PIPE ASSY 1	1		1	1	
	1P8-14610-10	EXHAUST PIPE ASSY 1		1			
2	5MW-14642-00	SEAL, EXHAUST	2	2	2	2	
3	90507-20052	SPRING, TENSION	2	2	2	2	
4	5CU-14771-01	STAY, MUFFLER 1	1	1	1	1	
5	90480-16561	GROMMET	1	1	1	1	
6	90387-063G3	COLLAR	1	1	1	1	
7	90201-06071	WASHER, PLATE	1	1	1	1	
8	5XF-14781-00	STAY, MUFFLER 2	1	1	1	1	
9	90119-06192	BOLT, WITH WASHER	1	1	1	1	
10	90119-06192	BOLT, WITH WASHER	1	1	1	1	
11	95027-06025	BOLT, FLANGE	1	1	1	1	
12	90387-08030	COLLAR	1	1	1	1	
13	95027-08035	BOLT, FLANGE	1	1	1	1	
14	90201-08730	WASHER, PLATE	1	1	1	1	
15	3JE-14615-01	JOINT, EXHAUST 1	1	1	1	1	
16	5NX-14753-11	SILENCER, EXHAUST	1				UR FOR USA
	5NX-14753-01	SILENCER, EXHAUST	1	1	1	1	UR EXCEPT FOR USA
17	92017-06010	.BOLT, BUTTON HEAD	2	2	2	2	
18	5HC-1469A-10	.FIBER	1				UR FOR USA
	5CU-1469A-00	.FIBER	1	1	1	1	UR EXCEPT FOR USA
19	90480-16561	GROMMET	1	1	1	1	
20	90387-063G3	COLLAR	1	1	1	1	
21	90480-16404	GROMMET	1	1	1	1	
22	90387-06039	COLLAR	1	1	1	1	
23	95027-06025	BOLT, FLANGE	1	1	1	1	
24	90201-06071	WASHER, PLATE	1	1	1	1	

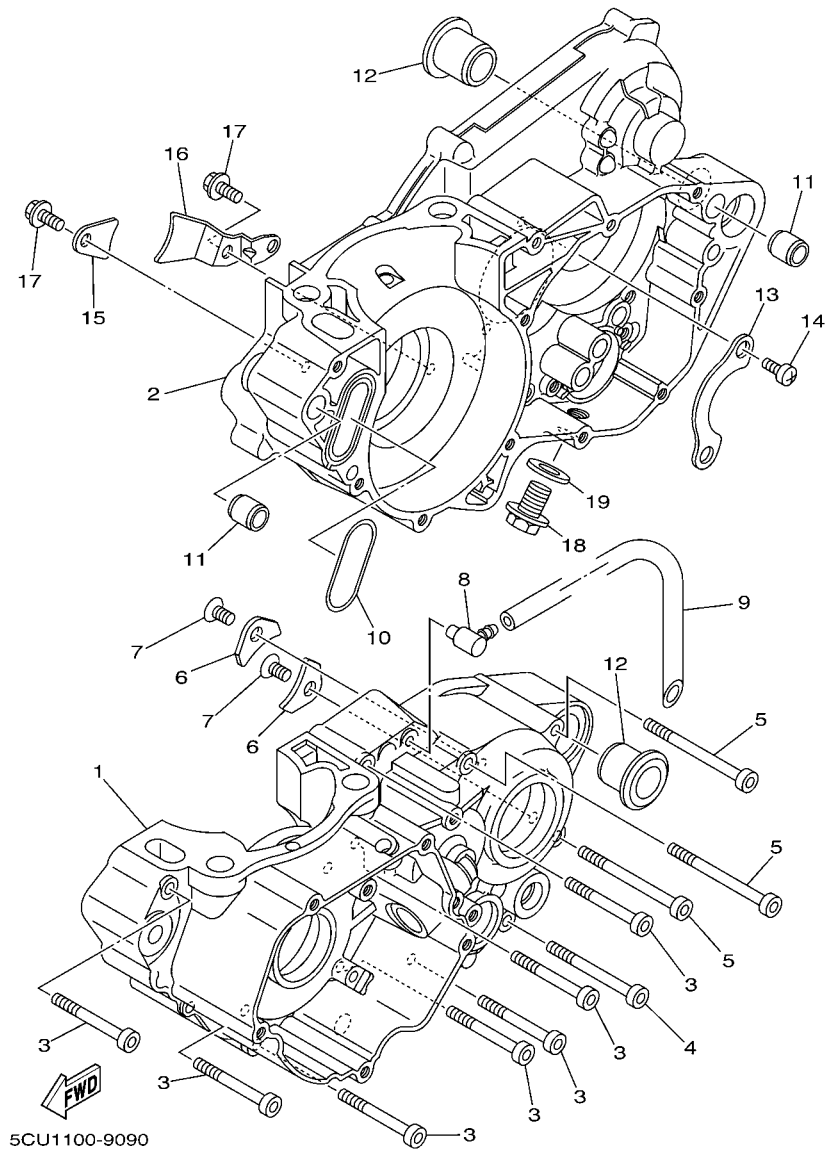

FIG. 9 CRANKCASE

REF. NO.	PART NO.	DESCRIPTION	1P81	1P82	1P83	1P84	REMARKS
1	5NX-15111-00	CRANKCASE 1	1	1	1	1	
2	5NX-15121-00	CRANKCASE 2	1	1	1	1	
3	91317-06050	BOLT	7	7	7	7	
4	91317-06060	BOLT	1	1	1	1	
5	91317-06070	BOLT	3	3	3	3	
6	4JT-15381-01	PLATE, BEARING COVER	2	2	2	2	
7	90149-06326	SCREW	2	2	2	2	
8	353-13115-01	CONNECTOR, SUCTION PIPE	1	1	1	1	
9	90445-08376	HOSE (L330)	1	1	1	1	
10	5CU-15454-00	GASKET, AIR CLEANER COVER 1	1	1	1	1	
11	93612-16254	PIN, DOWEL	2	2	2	2	
12	90387-18007	COLLAR	2	2	2	2	
13	4L0-17471-00	PLATE, COVER	1	1	1	1	
14	90157-06077	SCREW, PAN HEAD	2	2	2	2	
15	4V4-15118-00	HOLDER	1	1	1	1	
16	5CU-15118-00	HOLDER	1	1	1	1	
17	90105-06556	BOLT, FLANGE	2	2	2	2	
18	90340-12059	PLUG, STRAIGHT SCREW	1	1	1	1	
19	90430-12227	GASKET	1	1	1	1	

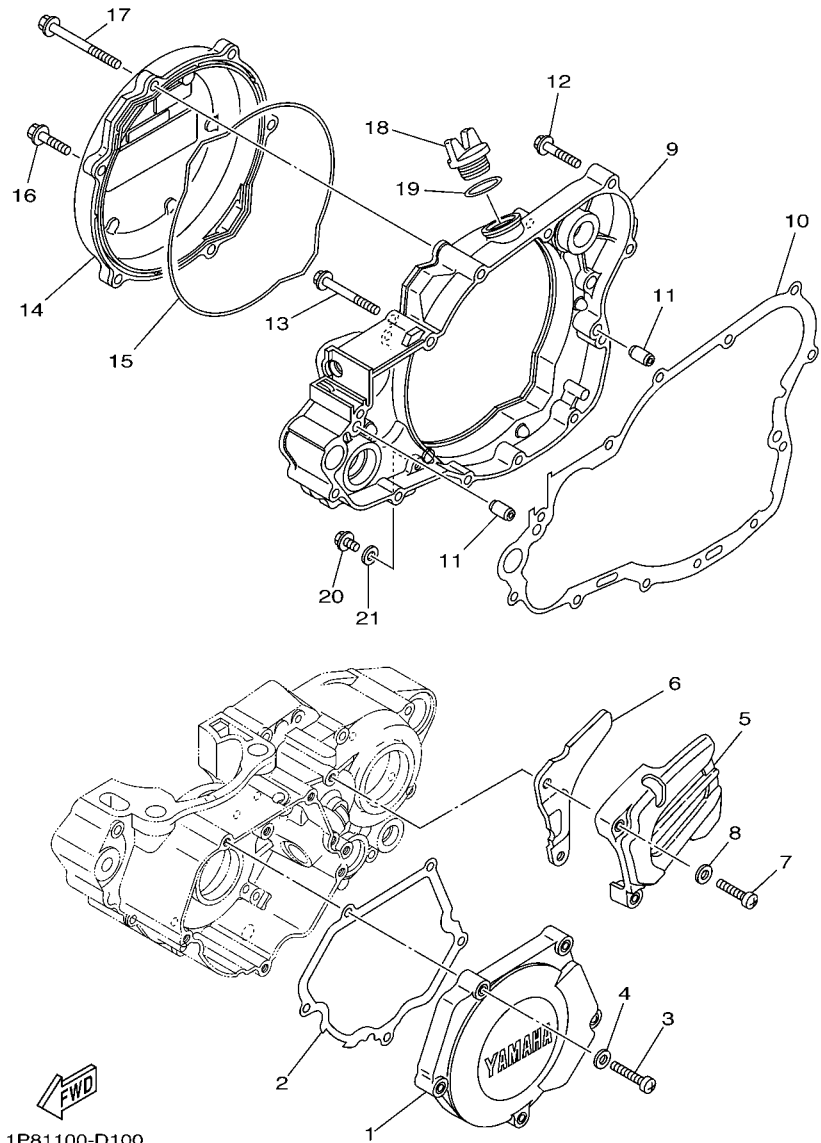

FIG. 10 CRANKCASE COVER 1

REF. NO.	PART NO.	DESCRIPTION	1P81	1P82	1P83	1P84	REMARKS
1	5CU-15411-00	COVER, CRANKCASE 1	1	1	1	1	
2	5CU-15451-00	GASKET, CRANKCASE COVER 1	1	1	1	1	
3	98507-06030	SCREW, PAN HEAD	5	5	5	5	
4	92907-06600	WASHER, PLATE	5	5	5	5	
5	1P8-15421-00	COVER, CRANKCASE 2	1	1	1	1	
6	5HC-17466-00	GUIDE, CHAIN	1	1	1	1	
7	98507-06030	SCREW, PAN HEAD	2	2	2	2	
8	92907-06600	WASHER, PLATE	2	2	2	2	
9	5NX-15431-00	COVER, CRANKCASE 3	1	1	1	1	
10	5CU-15462-00	GASKET, CRANKCASE COVER 3	1	1	1	1	
11	99530-08016	PIN, DOWEL	2	2	2	2	
12	95027-06030	BOLT, FLANGE	8	8	8	8	
13	95027-06050	BOLT, FLANGE	1	1	1	1	
14	5MW-15415-00	COVER, GENERATOR	1	1	1	1	
15	5CU-15463-00	GASKET, CARBURETOR COVER 2	1	1	1	1	
16	95027-06025	BOLT, FLANGE	5	5	5	5	
17	95027-06065	BOLT, FLANGE	1	1	1	1	
18	3Y1-15363-00	PLUG, OIL	1	1	1	1	
19	93210-19123	O-RING	1	1	1	1	
20	95027-06010	BOLT, FLANGE	1	1	1	1	
21	90430-06014	GASKET	1	1	1	1	

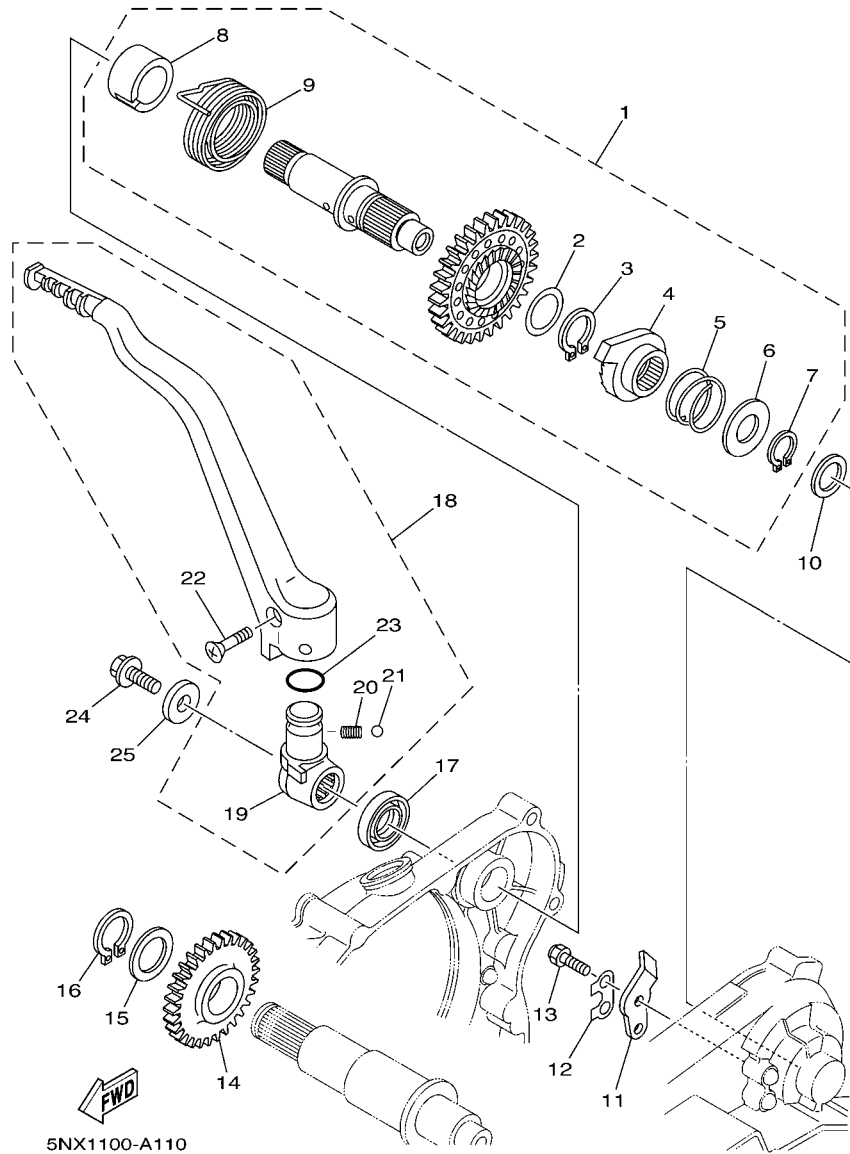
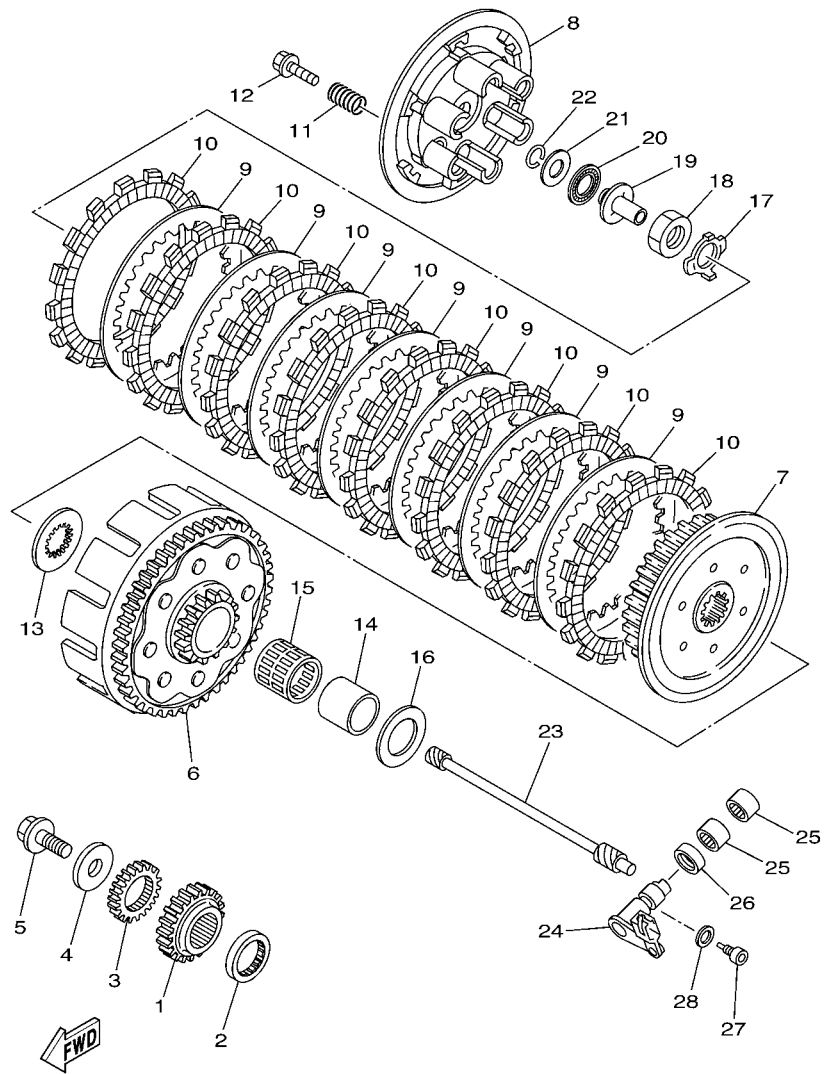

FIG. 11 STARTER

REF. NO.	PART NO.	DESCRIPTION	1P81	1P82	1P83	1P84	REMARKS
1	5NX-15601-10	KICK SHAFT ASSY	1	1	1	1	
2	90201-20685	.WASHER, PLATE (T=0.5)	1	1	1	1	
3	93410-20038	.CIRCLIP	1	1	1	1	
4	4GY-15671-00	.WHEEL, RATCHET	1	1	1	1	
5	90501-16016	.SPRING, COMPRESSION	1	1	1	1	
6	90201-167P7	.WASHER, PLATE	1	1	1	1	
7	99009-16400	.CIRCLIP	1	1	1	1	
8	5NL-15664-00	.GUIDE, SPRING	1	1	1	1	
9	90508-30743	.SPRING, TORSION	1	1	1	1	
10	90201-162H4	WASHER, PLATE	1	1	1	1	
11	214-15674-00	GUIDE, RATCHET WHEEL	1	1	1	1	
12	214-15686-00	WASHER, LOCK	1	1	1	1	
13	97027-06016	BOLT	2	2	2	2	
14	5CU-15651-00	GEAR, KICK IDLE	1	1	1	1	
15	90201-20276	WASHER, PLATE (T=1.0)	1	1	1	1	
16	99009-20400	CIRCLIP	1	1	1	1	
17	93102-18278	OIL SEAL	1	1	1	1	
18	5NX-15620-10	KICK CRANK ASSY	1	1	1	1	
19	5NX-15621-10	.BOSS, KICK CRANK	1	1	1	1	
20	90501-147A5	.SPRING, COMPRESSION	1	1	1	1	
21	93507-32009	.BALL	1	1	1	1	
22	90152-06010	.SCREW, COUNTERSUNK	1	1	1	1	
23	93210-17570	.O-RING	1	1	1	1	
24	90109-085E2	BOLT	1	1	1	1	
25	90201-08326	WASHER, PLATE	1	1	1	1	

FIG. 12 CLUTCH



5NX1100-A120

REF. NO.	PART NO.	DESCRIPTION	1P81	1P82	1P83	1P84	REMARKS
1	5DJ-16111-00	GEAR, PRIMARY DRIVE	1	1	1	1	
2	5MW-16113-00	WASHER, THRUST 1	1	1	1	1	
3	5CU-11956-00	GEAR, GOVERNOR DRIVE	1	1	1	1	
4	90201-105P3	WASHER, PLATE	1	1	1	1	
5	90105-10445	BOLT, FLANGE	1	1	1	1	
6	5DJ-16150-00	PRIMARY DRIVEN GEAR COMP.	1	1	1	1	
7	5NX-16371-00	BOSS, CLUTCH	1	1	1	1	
8	5JG-16351-00	PLATE, PRESSURE 1	1	1	1	1	
9	4X7-16325-00	PLATE, CLUTCH 2	7	7	7	7	
10	3XK-16321-00	PLATE, FRICTION	8	8	8	8	
11	90501-237L0	SPRING, COMPRESSION	6	6	6	6	
12	90159-06010	SCREW, WITH WASHER	6	6	6	6	
13	5CU-16154-00	PLATE, THRUST 1	1	1	1	1	
14	2VM-16181-00	SPACER 1	1	1	1	1	
15	93310-230T7	BEARING	1	1	1	1	
16	2K7-16154-00	PLATE, THRUST 1	1	1	1	1	
17	90215-20231	WASHER, LOCK	1	1	1	1	
18	90170-20255	NUT	1	1	1	1	
19	4XL-16356-00	ROD, PUSH 1	1	1	1	1	
20	93340-21505	BEARING	1	1	1	1	
21	90201-125L6	WASHER, PLATE	1	1	1	1	
22	93440-10085	CIRCLIP	1	1	1	1	
23	1P8-16357-00	ROD, PUSH 2	1	1	1	1	
24	5CU-16380-10	PUSH LEVER ASSY	1	1	1	1	
25	93315-11206	BEARING	2	2	2	2	
26	93102-12224	OIL SEAL	1	1	1	1	
27	90109-056G0	BOLT	1	1	1	1	

FIG. 12 CLUTCH

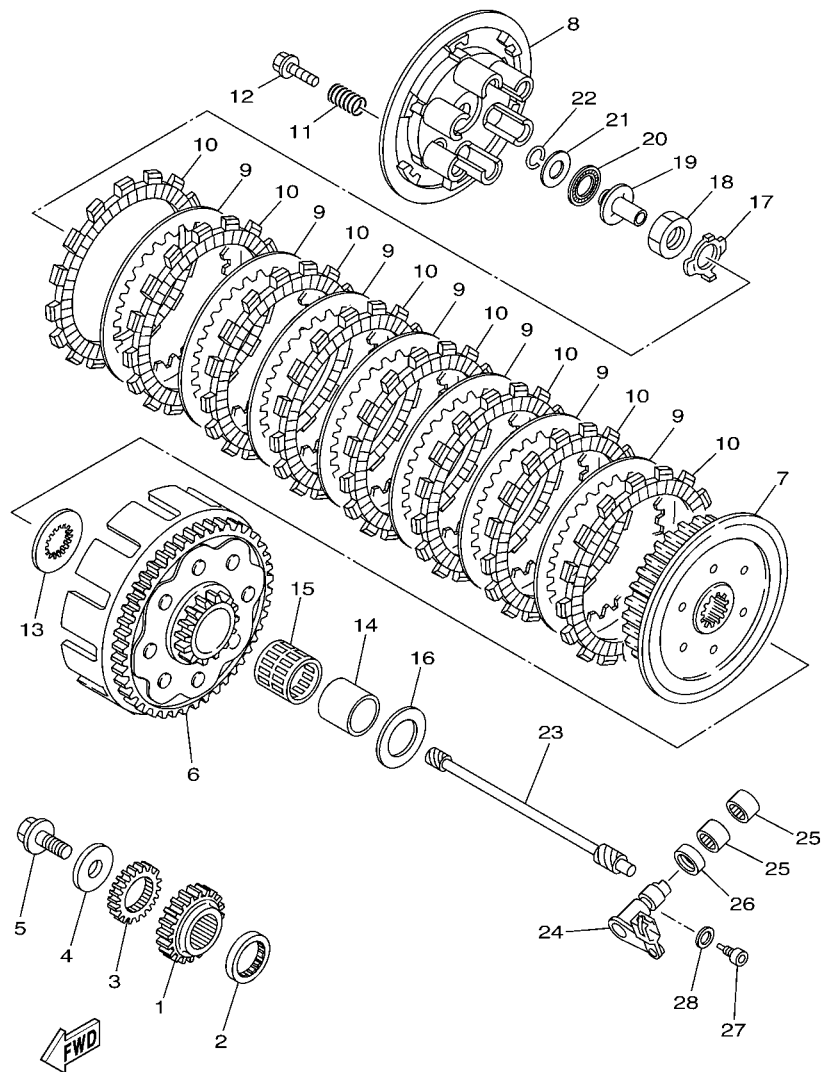

5NX1100-A120

REF. NO.	PART NO.	DESCRIPTION	1P81	1P82	1P83	1P84	REMARKS
28	90430-05242	GASKET	1	1	1	1	

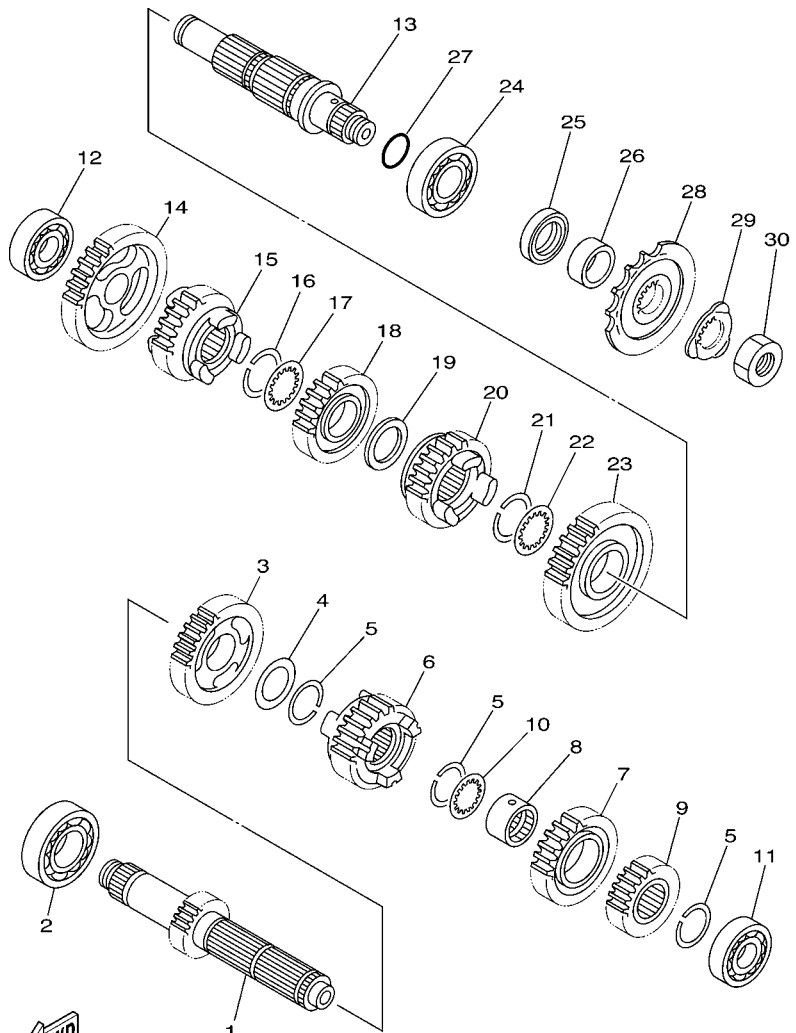

5CU1100-9130

FIG. 13 TRANSMISSION

REF. NO.	PART NO.	DESCRIPTION	1P81	1P82	1P83	1P84	REMARKS
1	5BE-17411-00	AXLE, MAIN (14T)	1	1	1	1	
2	93306-20540	BEARING	1	1	1	1	
3	5BE-17151-00	GEAR, 5TH PINION (21T)	1	1	1	1	
4	90201-253K0	WASHER, PLATE (T=1.0)	1	1	1	1	
5	93440-25084	CIRCLIP	3	3	3	3	
6	5CU-17131-00	GEAR, 3RD PINION (18T)	1	1	1	1	
7	5BE-17141-30	GEAR, 4TH PINION (22T)	1	1	1	1	
8	90387-2113G	COLLAR	1	1	1	1	
9	5JG-17121-10	GEAR, 2ND PINION (15T)	1	1	1	1	
10	90209-21332	WASHER	1	1	1	1	
11	93306-00442	BEARING	1	1	1	1	
12	93306-00426	BEARING	1	1	1	1	
13	5BE-17402-00	DRIVE AXLE ASSY	1	1	1	1	
14	5BE-17211-00	GEAR, 1ST WHEEL (27T)	1	1	1	1	
15	5BE-17251-10	GEAR, 5TH WHEEL (20T)	1	1	1	1	
16	93440-25084	CIRCLIP	1	1	1	1	
17	90209-21332	WASHER	1	1	1	1	
18	5BE-17231-00	GEAR, 3RD WHEEL (23T)	1	1	1	1	
19	90201-253K0	WASHER, PLATE (T=1.0)	1	1	1	1	
20	5JG-17241-00	GEAR, 4TH WHEEL (24T)	1	1	1	1	
21	93440-28062	CIRCLIP	1	1	1	1	
22	90209-26348	WASHER	1	1	1	1	
23	5JG-17221-10	GEAR, 2ND WHEEL (23T)	1	1	1	1	
24	93306-20574	BEARING	1	1	1	1	
25	93102-32337	OIL SEAL	1	1	1	1	
26	90387-2515B	COLLAR	1	1	1	1	
27	93210-22298	O-RING	1	1	1	1	

FIG. 14 SHIFT CAM & FORK

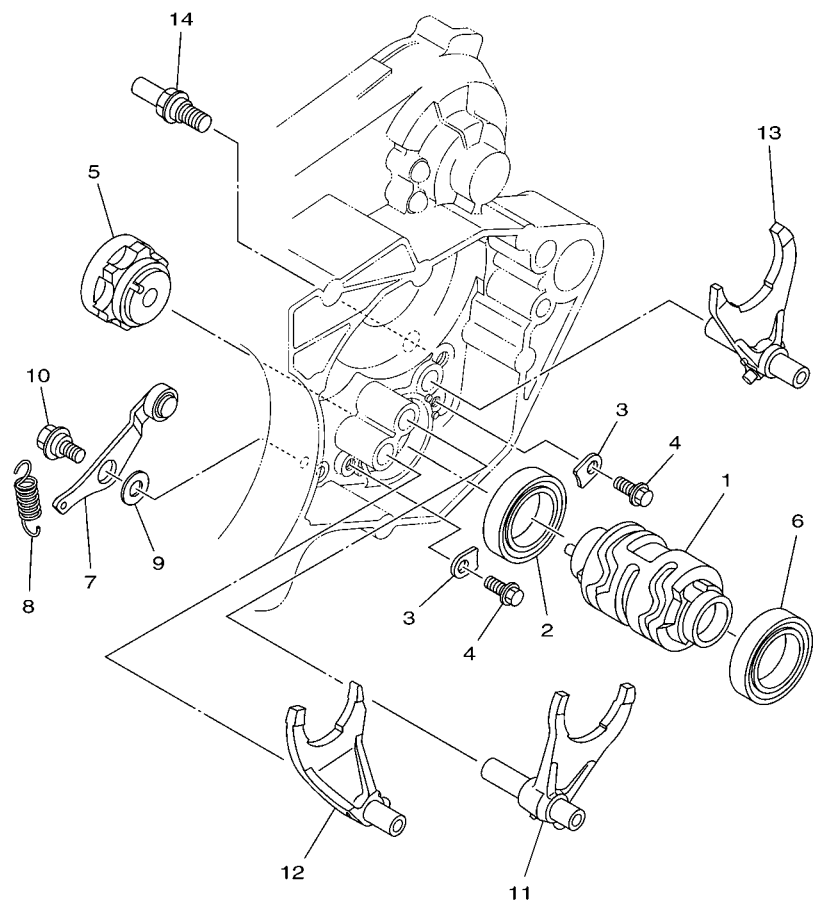

REF. NO.	PART NO.	DESCRIPTION	1P81	1P82	1P83	1P84	REMARKS
1	5MW-18541-00	CAM, SHIFT	1	1	1	1	
2	93306-90506	BEARING	1	1	1	1	
3	5DH-18562-00	PLATE, STOPPER 2	2	2	2	2	
4	90105-06553	BOLT, FLANGE	2	2	2	2	
5	4EW-18185-00	SEGMENT	1	1	1	1	
6	93306-90501	BEARING	1	1	1	1	
7	5CU-18140-01	STOPPER LEVER ASSY	1	1	1	1	
8	90507-14064	SPRING, TENSION	1	1	1	1	
9	90201-06013	WASHER, PLATE	1	1	1	1	
10	90109-066G1	BOLT	1	1	1	1	
11	5BE-18501-20	FORK, SHIFT 1	1	1	1	1	
12	5BE-18502-20	FORK, SHIFT 2	1	1	1	1	
13	5CU-18503-20	FORK, SHIFT 3	1	1	1	1	
14	4BR-18127-10	STOPPER, SCREW	1	1	1	1	

5MW1100-1140

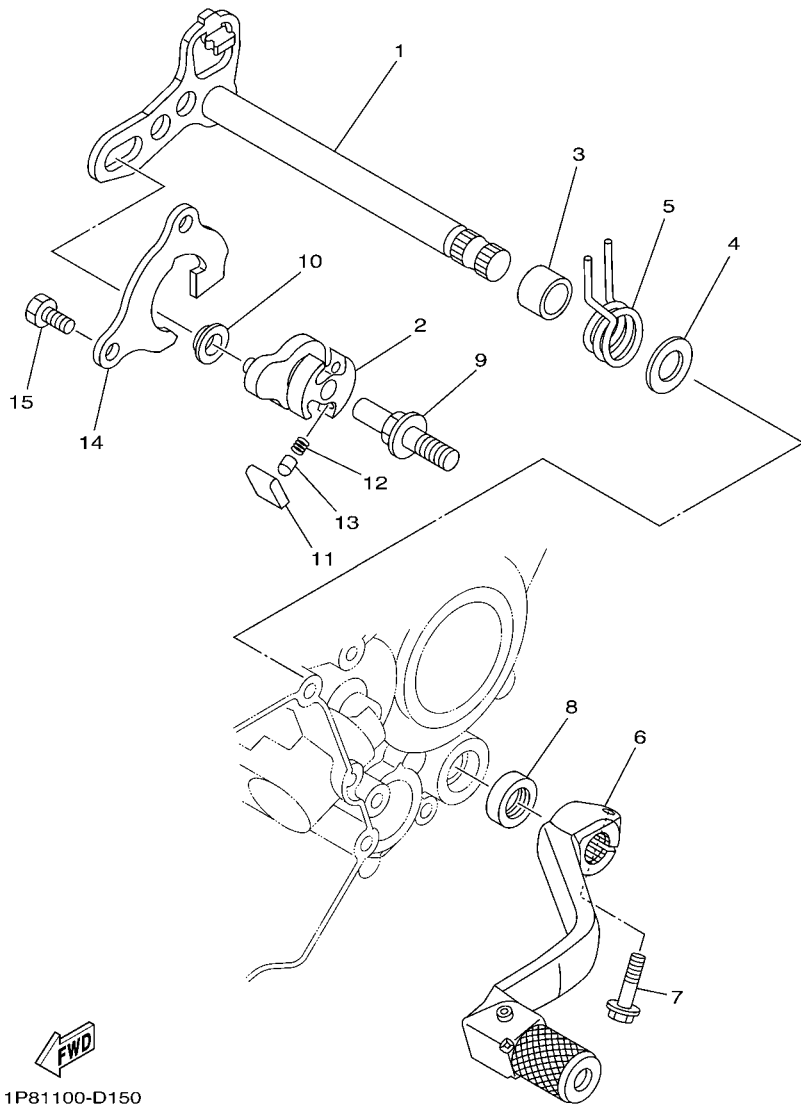

1P81100-D150

FIG. 15 SHIFT SHAFT

REF. NO.	PART NO.	DESCRIPTION	1P81	1P82	1P83	1P84	REMARKS
1	5CU-18101-10	SHIFT SHAFT ASSY	1	1	1	1	
2	5MW-18122-01	LEVER, SHIFT 2	1	1	1	1	
3	90387-124F4	COLLAR	1	1	1	1	
4	90201-12575	WASHER, PLATE	1	1	1	1	
5	90508-291A8	SPRING, TORSION	1	1	1	1	
6	1C3-18110-00	SHIFT PEDAL ASSY	1	1	1	1	
7	95027-06020	BOLT, FLANGE	1	1	1	1	
8	93102-12224	OIL SEAL	1	1	1	1	
9	3XJ-18173-00	PIN, SHIFT	1	1	1	1	
10	3XJ-18178-00	ROLLER, SHIFT LEVER	1	1	1	1	
11	3XJ-18182-00	PAWL, SHIFTER	2	2	2	2	
12	90501-052G5	SPRING, COMPRESSION	2	2	2	2	
13	3XJ-18184-00	PIN, PAWL	2	2	2	2	
14	5CU-18172-00	GUIDE, SHIFT	1	1	1	1	
15	90101-06034	BOLT	2	2	2	2	

FIG. 16 FRAME

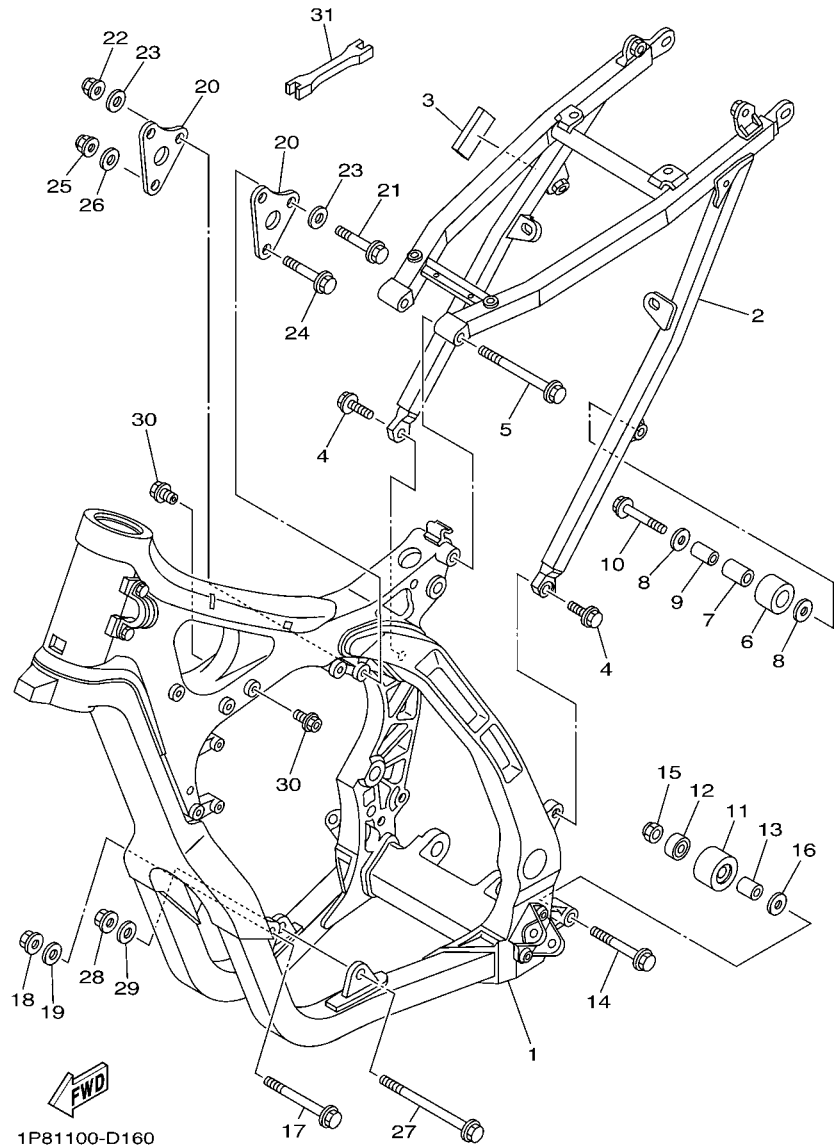

REF. NO.	PART NO.	DESCRIPTION	1P81	1P82	1P83	1P84	REMARKS
1	1P8-21101-00	FRONT FRAME COMP.	1	1	1	1	
2	1C3-21190-00	REAR FRAME COMP.	1	1	1	1	
3	5GJ-21717-00	DAMPER	1	1	1	1	
4	90105-08057	BOLT, FLANGE	2	2	2	2	
5	90105-08120	BOLT, FLANGE	1	1	1	1	
6	30X-22178-00	TENSIONER	1	1	1	1	
7	4V4-22184-00	BUSH	1	1	1	1	
8	90201-08039	WASHER, PLATE	2	2	2	2	
9	90387-08027	COLLAR	1	1	1	1	
10	95027-08040	BOLT, FLANGE	1	1	1	1	
11	3JD-22178-20	TENSIONER	1	1	1	1	
12	93300-60804	BEARING	1	1	1	1	
13	90387-086N4	COLLAR	1	1	1	1	
14	95027-08055	BOLT, FLANGE	1	1	1	1	
15	90185-08055	NUT, SELF-LOCKING	1	1	1	1	
16	90201-086P8	WASHER, PLATE	1	1	1	1	
17	90105-10733	BOLT, FLANGE	1	1	1	1	
18	90179-10658	NUT	1	1	1	1	
19	92907-10200	WASHER, PLAIN	1	1	1	1	
20	5NX-21425-00	BRACKET, REAR UPPER 1	2	2	2	2	
21	90105-08059	BOLT, FLANGE	2	2	2	2	
22	90179-08674	NUT	2	2	2	2	
23	90201-08730	WASHER, PLATE	4	4	4	4	
24	90105-10074	BOLT, FLANGE	1	1	1	1	
25	90179-10658	NUT	1	1	1	1	
26	92907-10200	WASHER, PLAIN	1	1	1	1	
27	90105-10079	BOLT, FLANGE	1	1	1	1	

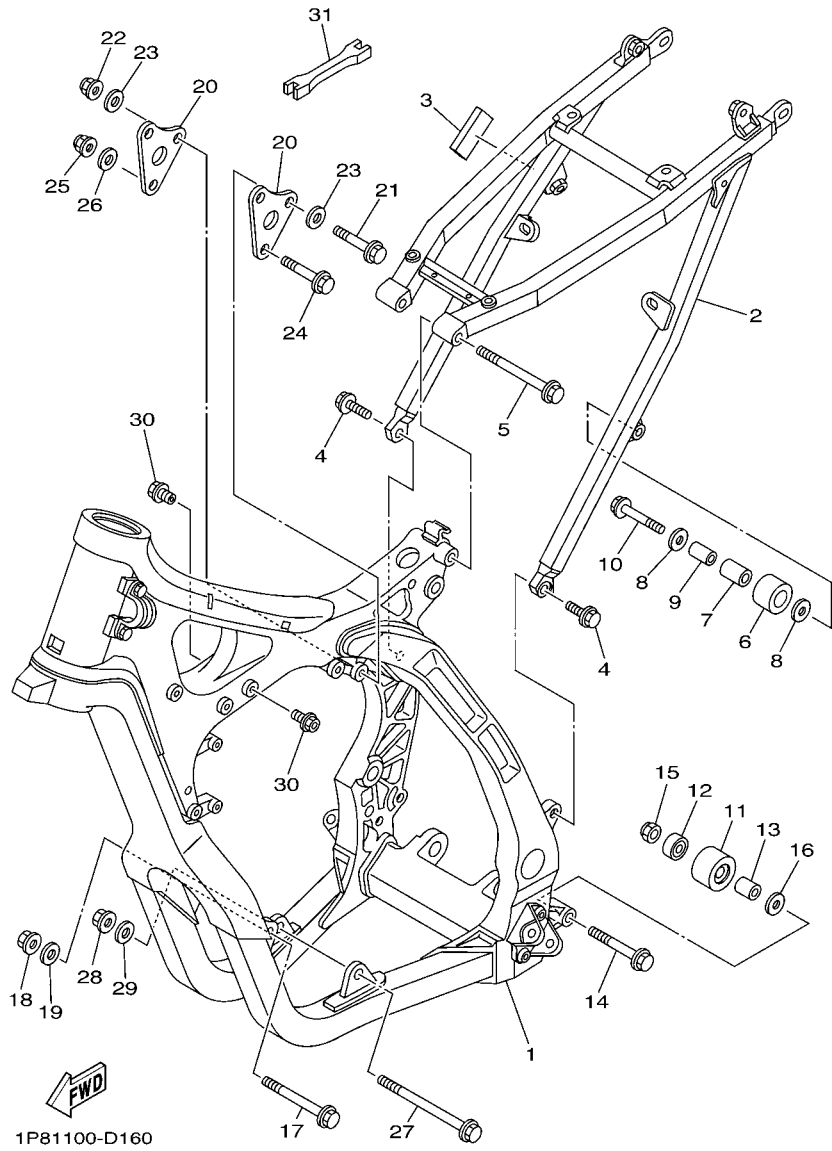
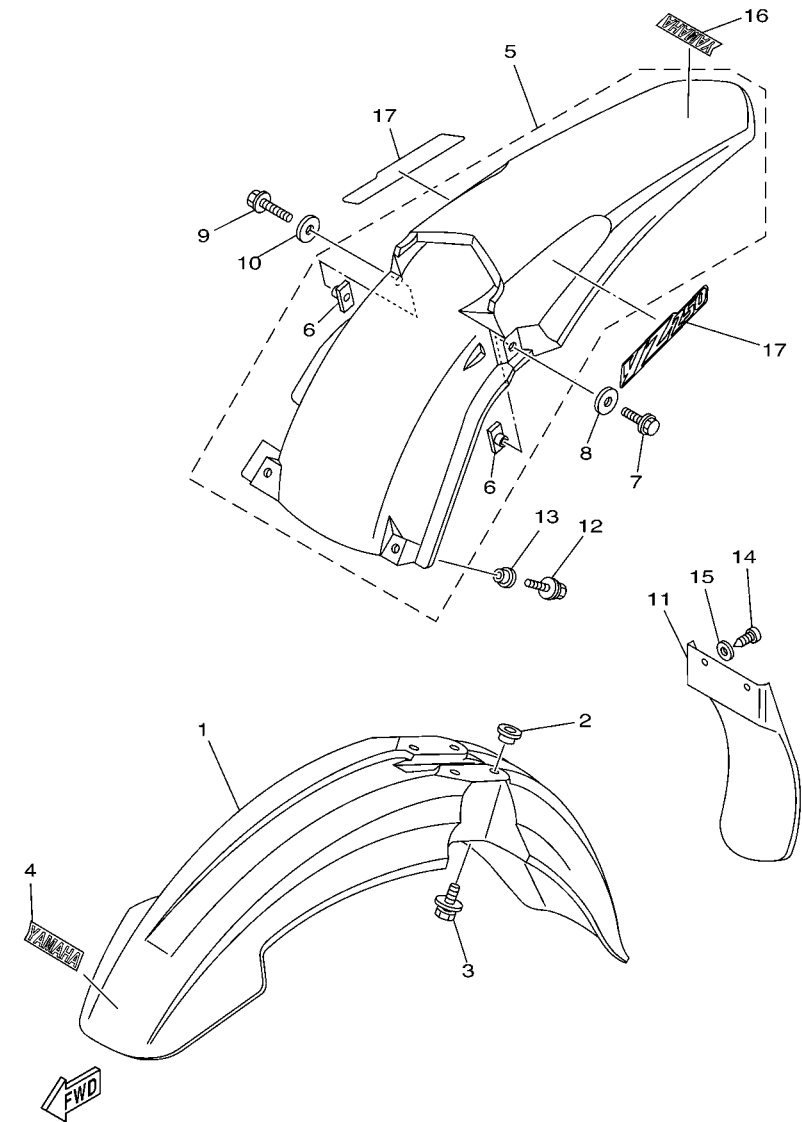

FIG. 16 FRAME

REF. NO.	PART NO.	DESCRIPTION	1P81	1P82	1P83	1P84	REMARKS
28	90179-10658	NUT	1	1	1	1	
29	92907-10200	WASHER, PLAIN	1	1	1	1	
30	1C3-21244-00	NUT	2	2	2	2	
31	5ET-28166-00	WRENCH, HEXAGON	1	1	1	1	



5XF1100-C170

FIG. 17 FENDER

REF. NO.	PART NO.	DESCRIPTION	1P81	1P82	1P83	1P84	REMARKS
1	5HD-21511-00	FENDER, FRONT	1	1	1	1	
2	90387-06090	COLLAR	4	4	4	4	
3	90119-06096	BOLT, WITH WASHER	4	4	4	4	
4	4ES-2153E-01	EMBLEM, YAMAHA	1	1	1	1	
5	5XE-21610-00	REAR FENDER COMP.	1	1	1	1	
6	5XE-21635-00	.NUT, REAR FENDER	2	2	2	2	
7	90105-06045	BOLT, FLANGE	1	1	1	1	
8	90201-062A8	WASHER, PLATE	1	1	1	1	
9	90105-06046	BOLT, FLANGE	1	1	1	1	
10	90201-06071	WASHER, PLATE	1	1	1	1	
11	5UN-21642-00	GUARD, FLAP	1	1	1	1	
12	90119-06225	BOLT, WITH WASHER	2	2	2	2	
13	90387-06009	COLLAR	2	2	2	2	
14	97707-60016	SCREW, TAPPING	2	2	2	2	
15	90201-06557	WASHER, PLATE	2	2	2	2	
16	4ES-2153E-01	EMBLEM, YAMAHA	1	1	1	1	
17	5XF-2163G-00	EMBLEM 1	2	2	2	2	

FIG. 18 SIDE COVER

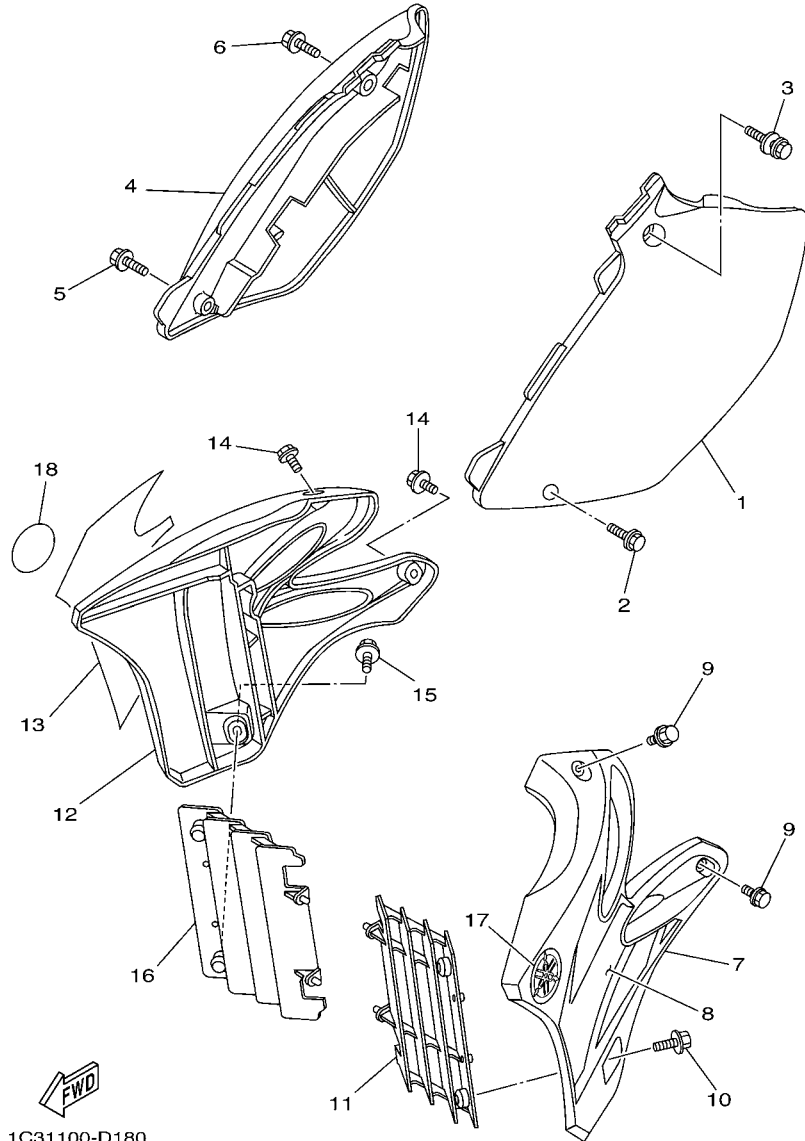

1C31100-D180

REF. NO.	PART NO.	DESCRIPTION	1P81	1P82	1P83	1P84	REMARKS
1	5NY-21711-00	COVER, SIDE 1	1	1	1	1	
2	95827-06016	BOLT, FLANGE	1	1	1	1	
3	90119-08238	BOLT, WITH WASHER	1	1	1	1	
4	5NY-21721-00	COVER, SIDE 2	1	1	1	1	
5	95827-06016	BOLT, FLANGE	1	1	1	1	
6	90119-08238	BOLT, WITH WASHER	1	1	1	1	
7	5XE-21730-00	SIDE COVER ASSY 3	1	1	1	1	
8	1C3-2173E-00	GRAPHIC 1	1	1	1	1	
9	90105-06055	BOLT, FLANGE	2	2	2	2	
10	90159-06078	SCREW, WITH WASHER	1	1	1	1	
11	5NL-2172A-11	PANEL 1	1	1	1	1	
12	5XE-21740-00	SIDE COVER ASSY 4	1	1	1	1	
13	1C3-2173F-00	GRAPHIC 2	1	1	1	1	
14	90105-06055	BOLT, FLANGE	2	2	2	2	
15	90159-06078	SCREW, WITH WASHER	1	1	1	1	
16	5NL-2172A-11	PANEL 1	1	1	1	1	
17	5MV-2175C-00	TUNING FORK MARK	1	1	1	1	
18	5MV-2175C-00	TUNING FORK MARK	1	1	1	1	

FIG. 19 REAR ARM

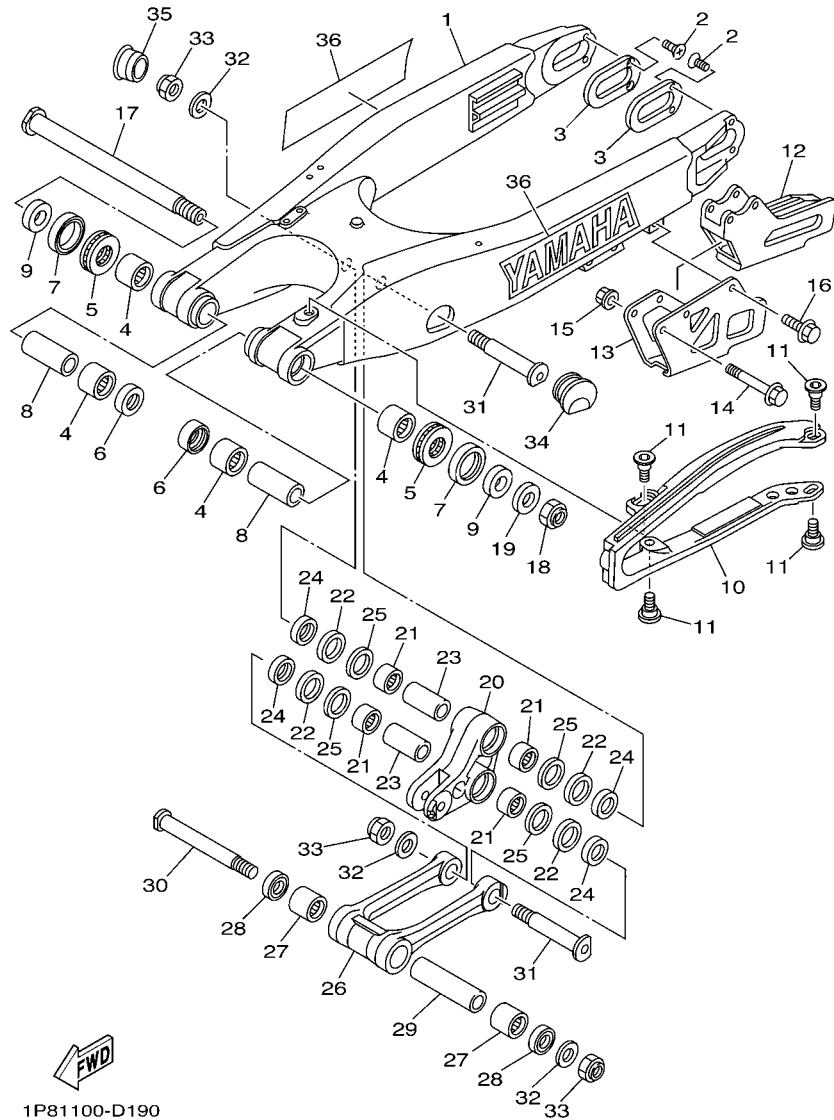

REF. NO.	PART NO.	DESCRIPTION	1P81	1P82	1P83	1P84	REMARKS
1	1C3-22110-00	REAR ARM COMP.	1	1	1	1	
2	90151-04001	SCREW, COUNTERSUNK	4	4	4	4	
3	1P8-22355-00	PATCH	2	2	2	2	
4	93317-22262	BEARING	4	4	4	4	
5	93342-22217	BEARING	2	2	2	2	
6	93106-22019	OIL SEAL (DC 22-28-8)	2	2	2	2	
7	93109-28043	OIL SEAL	2	2	2	2	
8	90387-18004	COLLAR	2	2	2	2	
9	90387-18009	COLLAR	2	2	2	2	
10	1C3-22151-00	SEAL, GUARD	1	1	1	1	
11	1C3-22969-00	SCREW, 1	4	4	4	4	
12	1C3-22199-00	SUPPORT, CHAIN	1	1	1	1	
13	1C3-22128-00	COVER, THRUST 1	1	1	1	1	
14	95027-06050	BOLT, FLANGE	2	2	2	2	
15	90179-06568	NUT	2	2	2	2	
16	95027-06010	BOLT, FLANGE	1	1	1	1	
17	1C3-22141-00	SHAFT, PIVOT	1	1	1	1	
18	90185-16127	NUT, SELF-LOCKING	1	1	1	1	
19	90201-160F6	WASHER, PLATE	1	1	1	1	
20	1C3-2217A-00	ARM, RELAY	1	1	1	1	
21	93315-32166	BEARING	4	4	4	4	
22	93109-25001	OIL SEAL	4	4	4	4	
23	90387-16010	COLLAR	2	2	2	2	
24	90209-16008	WASHER	4	4	4	4	
25	90201-21013	WASHER, PLATE	4	4	4	4	
26	1C3-2217F-00	ROD, CONNECTING 1	1	1	1	1	
27	93315-32165	BEARING	2	2	2	2	

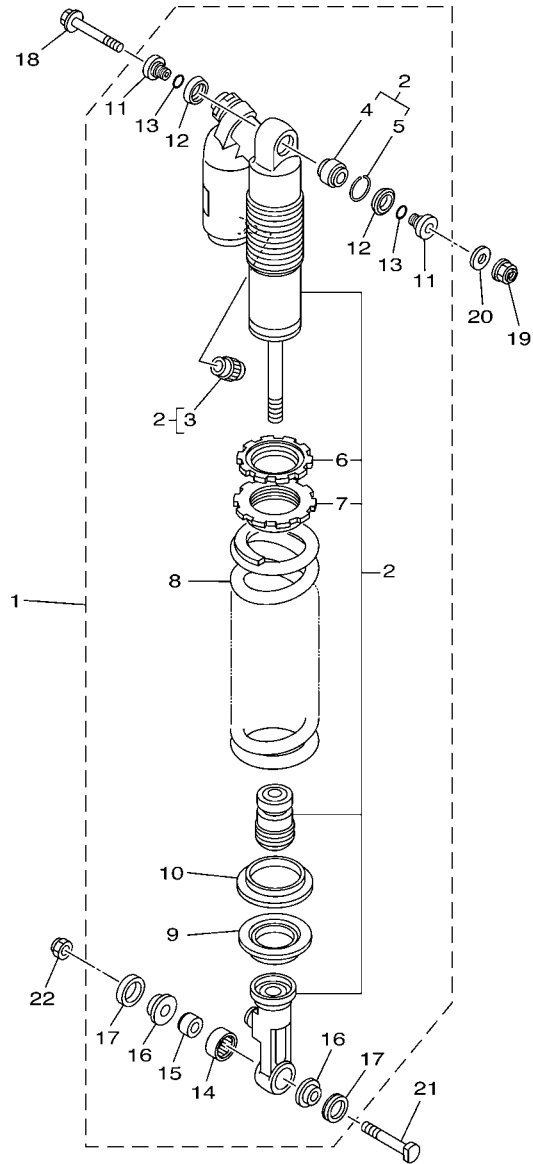

1C31100-D200

FIG. 20 REAR SUSPENSION

REF. NO.	PART NO.	DESCRIPTION	1P81	1P82	1P83	1P84	REMARKS
1	1P8-22210-00	SHOCK ABSORBER ASSY, REAR	1				UR FOR USA
	1P8-22210-30	SHOCK ABSORBER ASSY, REAR	1				UR FOR CAN
	1P8-22210-40	SHOCK ABSORBER ASSY, REAR	1			1	UR FOR ZAF
	1P8-22210-10	SHOCK ABSORBER ASSY, REAR		1			
	1P8-22210-20	SHOCK ABSORBER ASSY, REAR			1		
2	1P8-22201-00	.DAMPER SUB ASSY	1				UR FOR USA
	1P8-22201-30	.DAMPER SUB ASSY	1				UR FOR CAN
	1P8-22201-40	.DAMPER SUB ASSY	1			1	UR FOR ZAF
	1P8-22201-10	.DAMPER SUB ASSY		1			
	1P8-22201-20	.DAMPER SUB ASSY			1		
3	509-23184-L0	..CAP, AIR VALVE	1	1	1	1	
4	4JX-22226-00	..BUSH, SHOCK ABSORBER LOWER	1	1	1	1	
5	5DH-23183-00	..CIRCLIP	1	1	1	1	
6	3SP-22234-00	..GUIDE, SPRING 3	1	1	1	1	
7	3SP-22213-00	..SEAT, SPRING UPPER	1	1	1	1	
8	5UN-22212-30	.SPRING (K=48N/MM)	1	1	1	1	
9	5XE-22214-00	.GUIDE, SPRING 1	1	1	1	1	
10	5MV-22224-00	.GUIDE, SPRING 2	1	1	1	1	
11	1C3-22253-00	.COLLAR, DISTANCE	2	2	2	2	
12	3JE-22475-00	.SEAL, DUST	2	2	2	2	
13	4EW-22474-00	.SEAL, RING	2	2	2	2	
14	5UN-22176-00	.BEARING	1	1	1	1	
15	5MV-22184-00	.BUSH	1	1	1	1	
16	5MV-22253-00	.COLLAR, DISTANCE	2	2	2	2	
17	5NY-22475-00	.SEAL, DUST	2	2	2	2	
18	5XE-22242-00	BOLT 2	1	1	1	1	
19	95607-10200	NUT, U FLANGE	1	1	1	1	

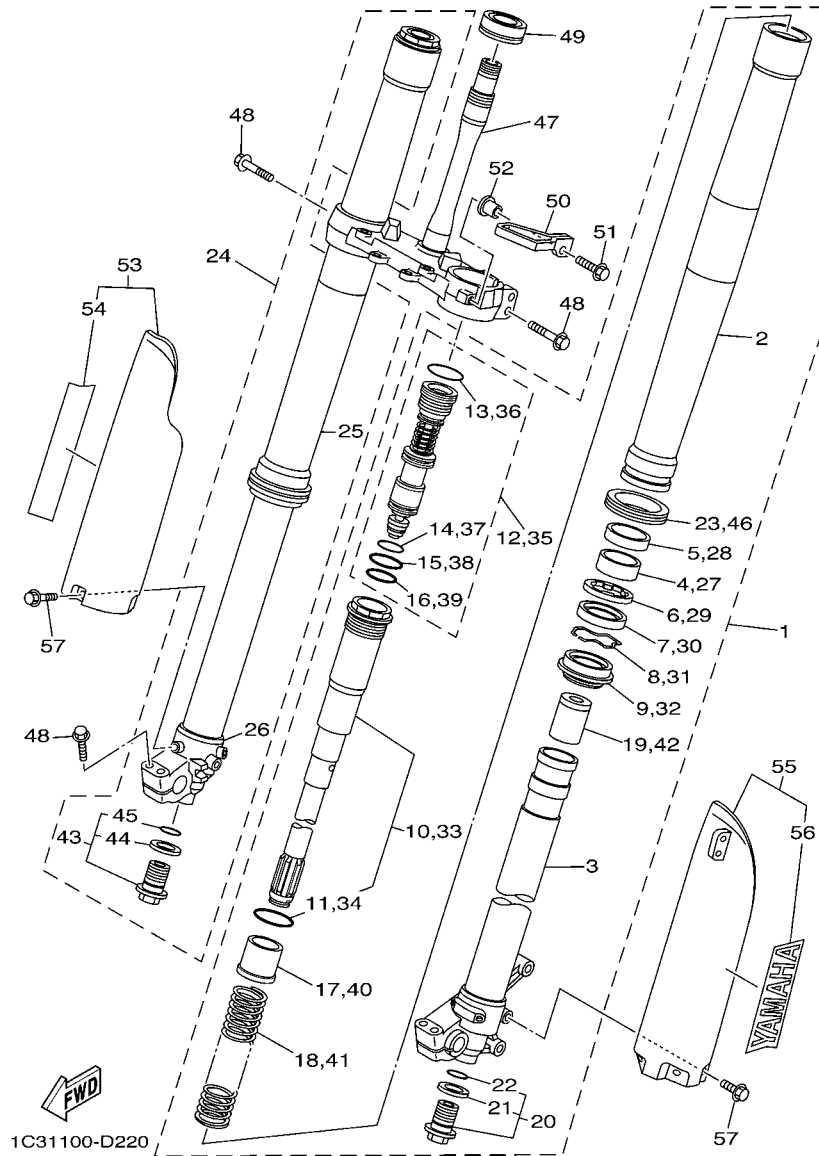

1C31100-D220

FIG. 22 FRONT FORK

REF. NO.	PART NO.	DESCRIPTION	1P81	1P82	1P83	1P84	REMARKS
1	1P8-23102-00	FRONT FORK ASSY (L.H)	1	1	1	1	
2	1C3-23136-L0	.TUBE, OUTER	1	1	1	1	
3	1P8-23120-L0	.INNER TUBE COMP.2	1	1	1	1	
4	5XE-23171-L0	.PISTON, FRONT FORK	1	1	1	1	
5	5XE-23125-L0	.METAL, SLIDE 1	1	1	1	1	
6	5XE-23146-L0	.WASHER, OIL SEAL	1	1	1	1	
7	1C3-23145-L0	.OIL SEAL	1	1	1	1	
8	5XE-23153-L0	.RING, SNAP	1	1	1	1	
9	5XE-23144-L0	.SEAL, DUST	1	1	1	1	
10	1C3-23170-L0	.CYLINDER COMP., FRONT FORK	1	1	1	1	
11	1C3-23147-L0	..O-RING	1	1	1	1	
12	1P8-2316A-L0	.VALVE COMP.	1	1	1	1	
13	1C3-23188-L0	..O-RING	1	1	1	1	
14	5UX-23188-00	..O-RING	1	1	1	1	
15	43F-23188-10	..O-RING	1	1	1	1	
16	1C3-23188-M0	..O-RING	1	1	1	1	
17	1C3-23118-L0	.SPACER	1	1	1	1	
18	1P8-23141-L0	.SPRING, FRONT FORK(K=4.3N/MM)	1	1	1	1	
19	1C3-2316E-L0	.SPACER	1	1	1	1	
20	1C3-23111-L0	.BOLT, CAP	1	1	1	1	
21	2HH-23158-L0	..GASKET	1	1	1	1	
22	276-23114-00	..GASKET	1	1	1	1	
23	1C3-2314F-L0	.PROTECTOR GUIDE COMP, 1	1	1	1	1	
24	1P8-23103-00	FRONT FORK ASSY (R.H)	1	1	1	1	
25	1C3-23136-L0	.TUBE, OUTER	1	1	1	1	
26	1P8-23110-L0	.INNER TUBE COMP.1	1	1	1	1	
27	5XE-23171-L0	.PISTON, FRONT FORK	1	1	1	1	

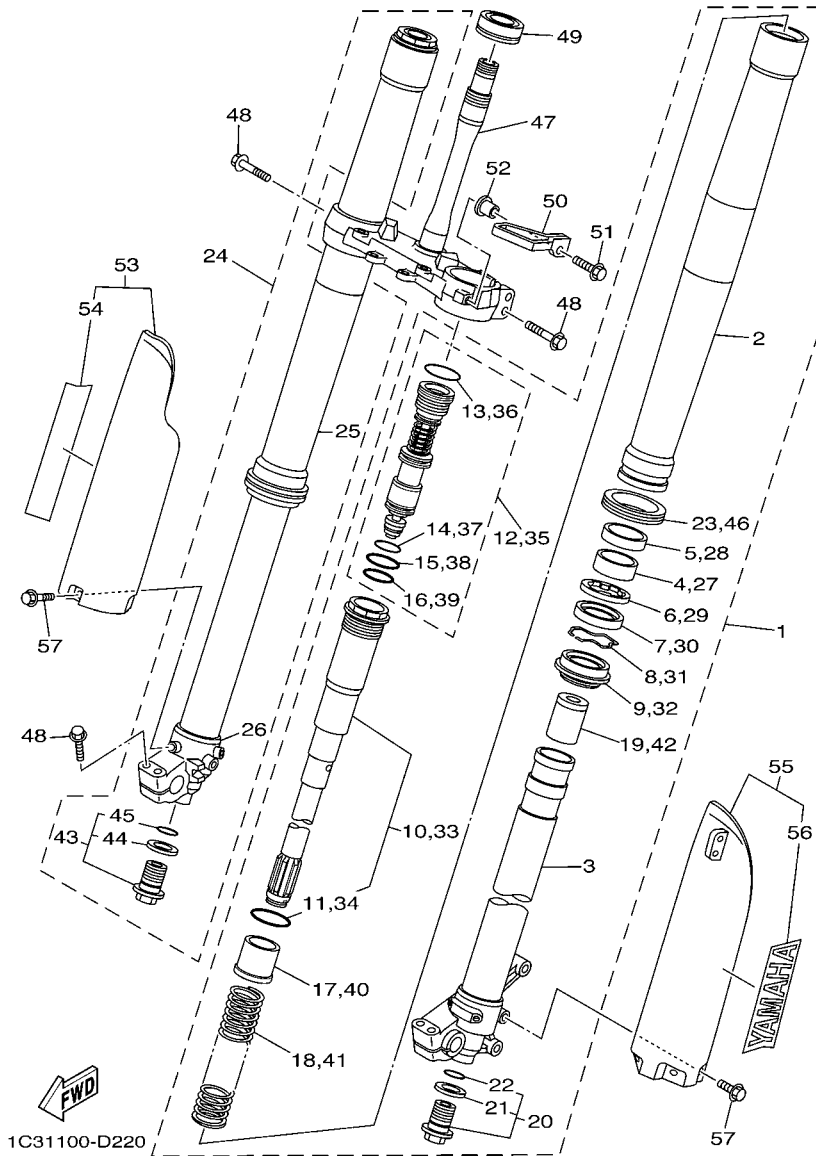
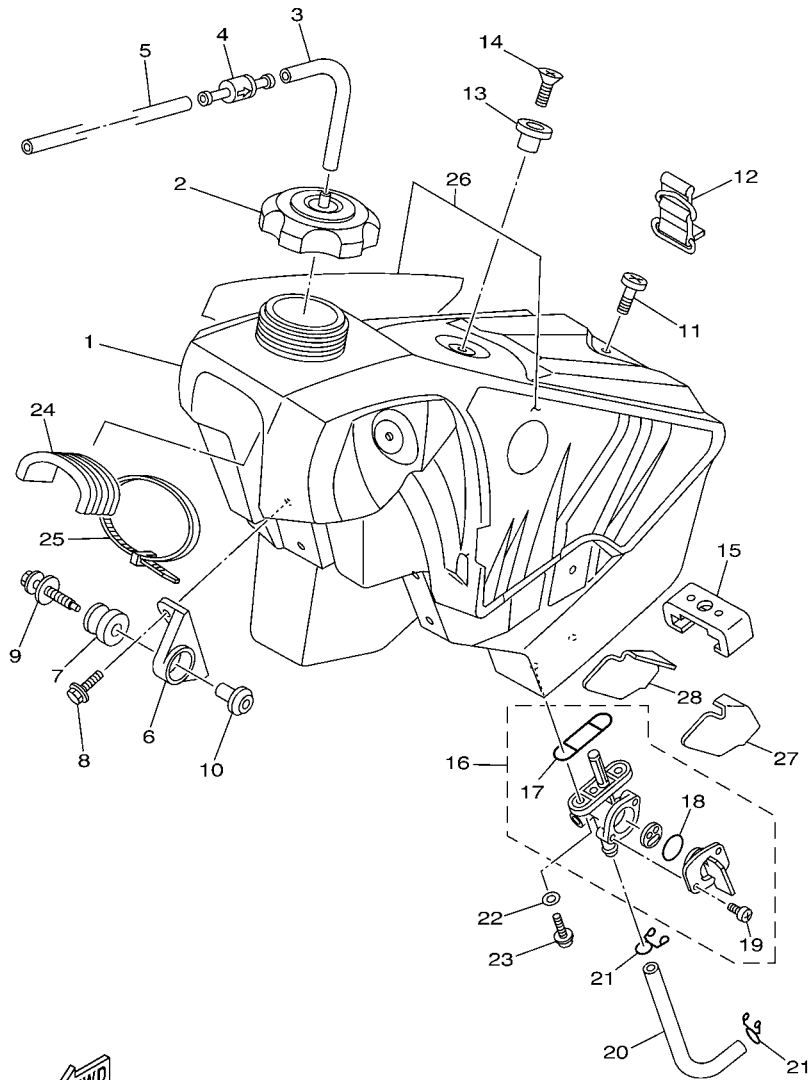

FIG. 22 FRONT FORK

REF. NO.	PART NO.	DESCRIPTION	1P81	1P82	1P83	1P84	REMARKS
28	5XE-23125-L0	.METAL, SLIDE 1	1	1	1	1	
29	5XE-23146-L0	.WASHER, OIL SEAL	1	1	1	1	
30	1C3-23145-L0	.OIL SEAL	1	1	1	1	
31	5XE-23153-L0	.RING, SNAP	1	1	1	1	
32	5XE-23144-L0	.SEAL, DUST	1	1	1	1	
33	1C3-23170-L0	.CYLINDER COMP., FRONT FORK	1	1	1	1	
34	1C3-23147-L0	..O-RING	1	1	1	1	
35	1P8-2316A-L0	.VALVE COMP.	1	1	1	1	
36	1C3-23188-L0	..O-RING	1	1	1	1	
37	5UX-23188-00	..O-RING	1	1	1	1	
38	43F-23188-10	..O-RING	1	1	1	1	
39	1C3-23188-M0	..O-RING	1	1	1	1	
40	1C3-23118-L0	.SPACER	1	1	1	1	
41	1P8-23141-L0	.SPRING, FRONT FORK(K=4.3N/MM)	1	1	1	1	
42	1C3-2316E-L0	.SPACER	1	1	1	1	
43	1C3-23111-L0	.BOLT, CAP	1	1	1	1	
44	2HH-23158-L0	..GASKET	1	1	1	1	
45	276-23114-00	..GASKET	1	1	1	1	
46	1C3-2314F-L0	.PROTECTOR GUIDE COMP., 1	1	1	1	1	
47	1P8-23340-L0	UNDER BRACKET COMP.	1	1	1	1	
48	5NY-23346-L0	BOLT 1	8	8	8	8	
49	93332-00081	BEARING	1	1	1	1	
50	5XE-23389-00	GUIDE, CABLE	1	1	1	1	
51	95027-06020	BOLT, FLANGE	1	1	1	1	
52	5XE-23113-00	COLLAR	1	1	1	1	
53	1C3-2314J-00	PROTECTOR COMP., 2	1	1	1	1	
54	4XL-2153A-10	.EMBLEM, YAMAHA	1	1	1	1	

FIG. 23 FUEL TANK



1C31100-D230

REF. NO.	PART NO.	DESCRIPTION	1P81	1P82	1P83	1P84	REMARKS
1	1C3-24110-00	FUEL TANK COMP.	1	1	1	1	
2	5NY-24610-00	CAP ASSY	1	1	1	1	
3	90445-09220	HOSE (L30)	1	1	1	1	
4	3XJ-24380-00	PIPE JOINT ASSY	1	1	1	1	
5	90445-09025	HOSE	1	1	1	1	
6	5XE-24144-00	HOLDER, DAMPER	2	2	2	2	
7	90480-18549	GROMMET	2	2	2	2	
8	95027-06016	BOLT, FLANGE	4	4	4	4	
9	5XE-24176-00	BOLT 1	2	2	2	2	
10	5NY-24186-00	WASHER, SPECIAL	2	2	2	2	
11	98907-06025	SCREW, BIND	1	1	1	1	
12	3SP-24173-00	BAND, TANK FITTING 1	1	1	1	1	
13	4EW-2412F-00	BRACKET, SEAT	1	1	1	1	
14	98707-06025	SCREW, FLAT HEAD	1	1	1	1	
15	1C3-24181-00	DAMPER, LOCATING 1	1	1	1	1	
16	3JD-24500-02	FUEL COCK ASSY 1	1	1	1	1	
17	4X8-24512-00	.O-RING	1	1	1	1	
18	3AJ-24534-01	.SEAL, COCK	1	1	1	1	
19	98507-03008	.SCREW, PAN HEAD	2	2	2	2	
20	90445-111J0	HOSE (L145)	1	1	1	1	
21	90467-10008	CLIP	2	2	2	2	
22	90202-05193	WASHER, PLATE	2	2	2	2	
23	90149-06011	SCREW	2	2	2	2	
24	1P8-24182-00	DAMPER, LOCATING 2	1	1	1	1	
25	90465-13275	CLAMP	1	1	1	1	
26	1C3-24240-00	GRAPHIC SET	1	1	1	1	
27	1C3-24183-00	DAMPER, LOCATING 3	1	1	1	1	

FIG. 23 FUEL TANK

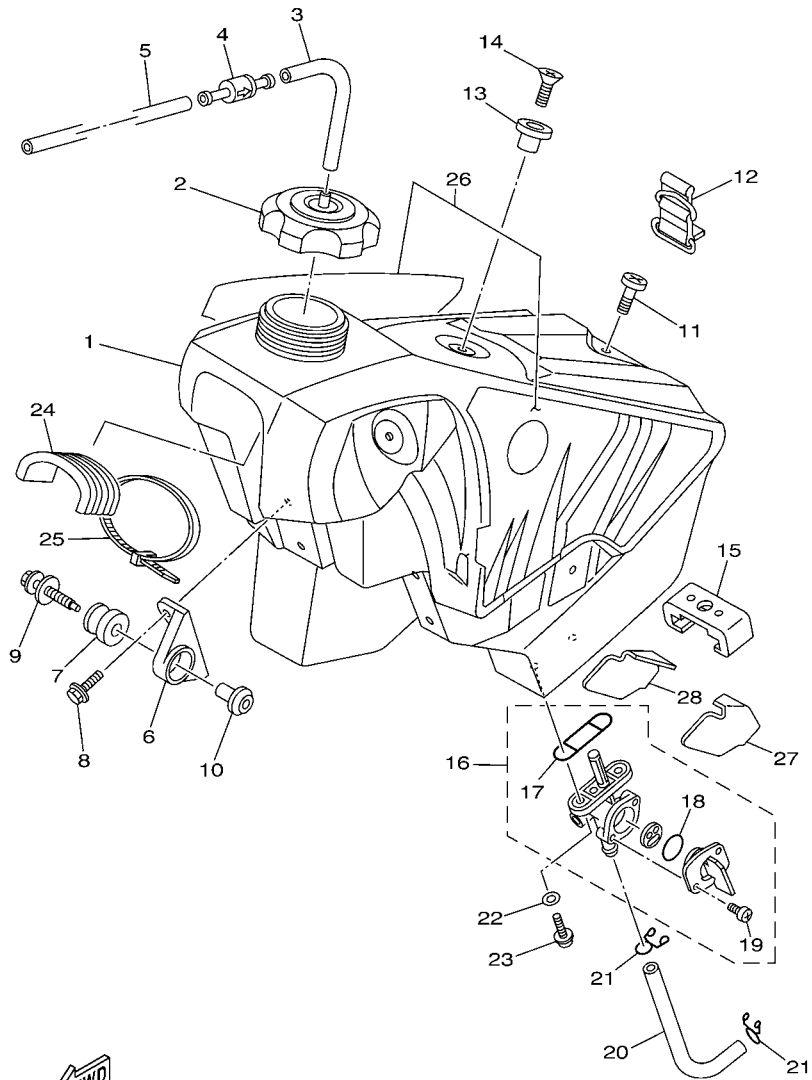



1C31100-D230

REF. NO.	PART NO.	DESCRIPTION	1P81	1P82	1P83	1P84	REMARKS
28	1C3-24184-00	DAMPER, LOCATING 4	1	1	1	1	

FIG. 25 FRONT WHEEL

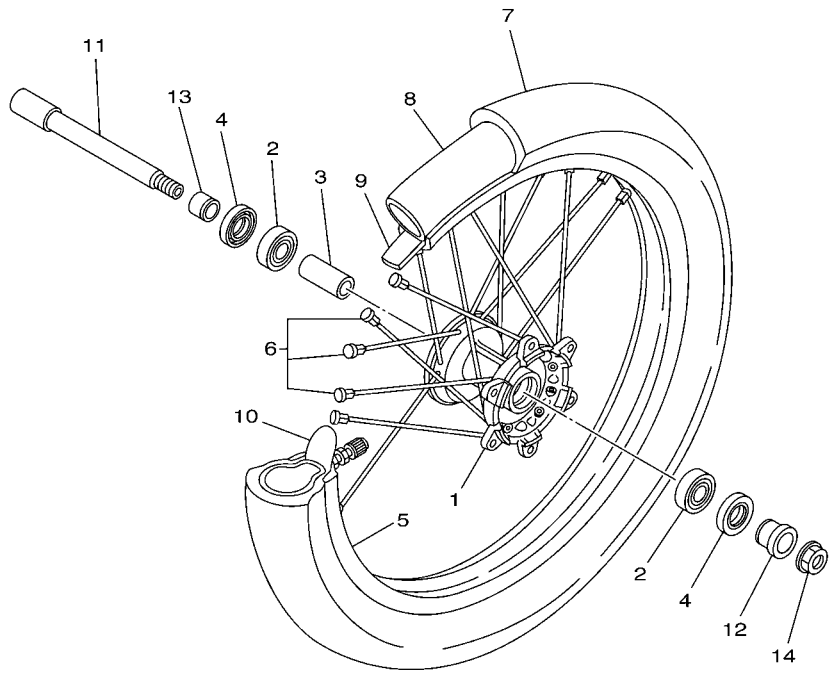
REF. NO.	PART NO.	DESCRIPTION	1P81	1P82	1P83	1P84	REMARKS
1	5NY-25111-00	HUB, FRONT	1	1	1	1	
2	93306-90403	BEARING	2	2	2	2	
3	5NY-25117-00	SPACER, BEARING	1	1	1	1	
4	93102-26468	OIL SEAL	2	2	2	2	
5	94416-21003	RIM (1.60-21)	1	1	1	1	
6	5NY-25104-00	SPOKE SET, FRONT	1	1	1	1	
7	94108-2112Y	TIRE (80/100-21 51M D755F)	1	1			DUNLOP FOR CAN
	94108-21015	TIRE (80/100-21 51M D739FA)	1			1	DUNLOP EXCEPT CAN
	94108-21012	TIRE(80/100-21 51M M601)			1		BRIDGESTONE
8	94227-21101	TUBE (80/100-21 M/C TR4)	1	1		1	DUNLOP
	94209-21229	TUBE (80/100-21 M/C TR4)			1		BRIDGESTONE
9	94309-21161	BAND, RIM (1.60-21)	1	1		1	DUNLOP
	94330-21084	BAND,RIM (1.60-21)			1		BRIDGESTONE
10	5SF-25394-00	SPACER, BEAD	1	1	1	1	
11	1C3-25181-00	AXLE, WHEEL	1	1	1	1	
12	5NY-25183-00	COLLAR, WHEEL	1	1	1	1	
13	5NY-25186-00	COLLAR, WHEEL	1	1	1	1	
14	90179-16002	NUT	1	1	1	1	



1C31100-D250

D9

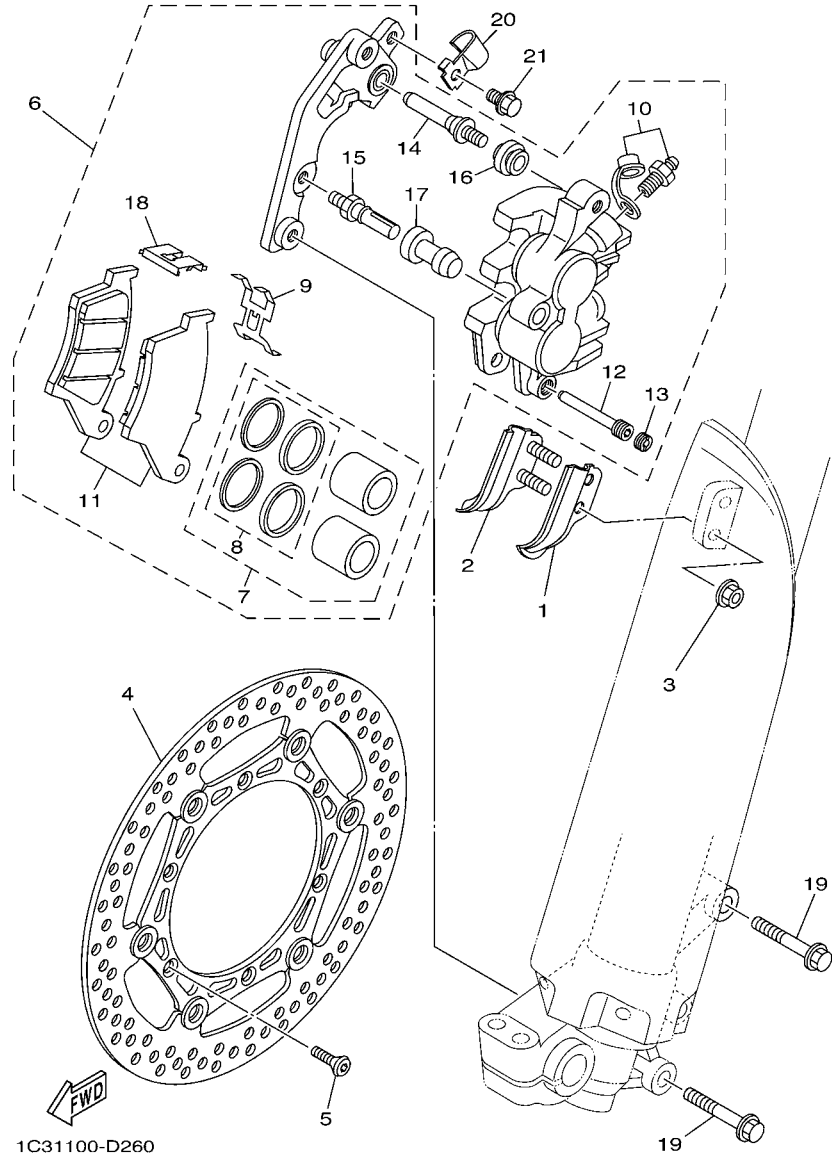
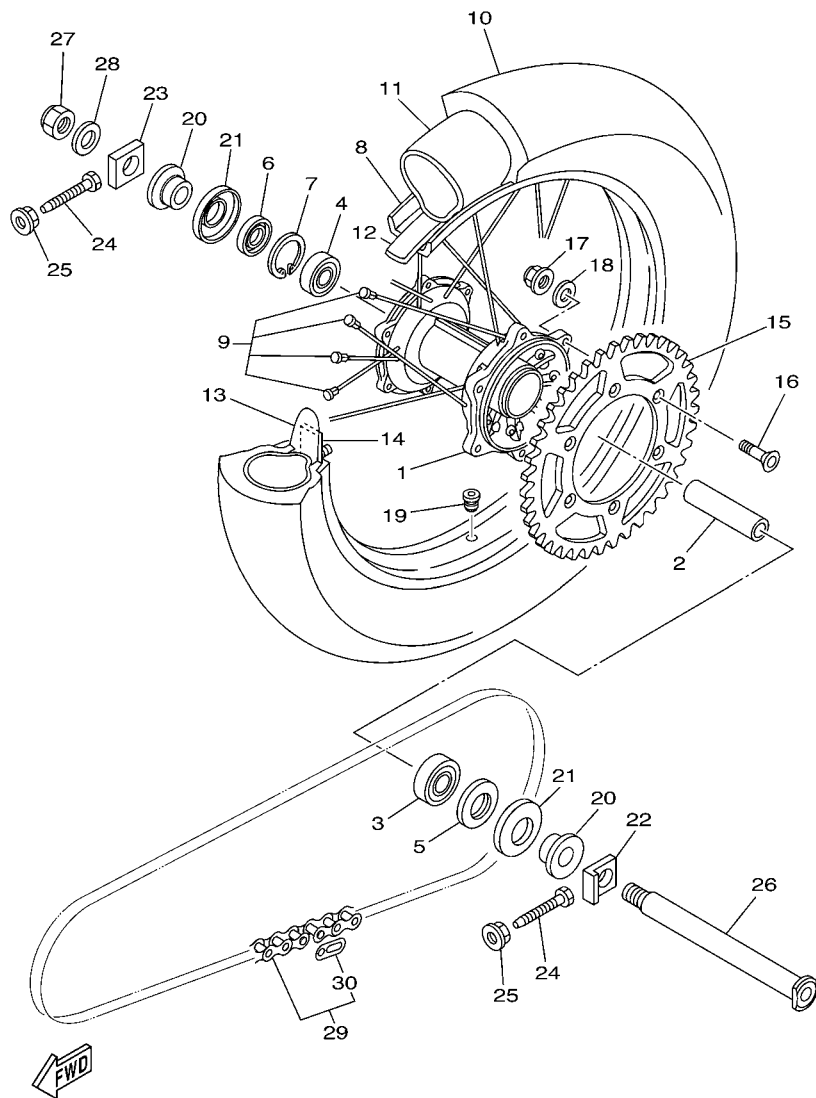

FIG. 26 FRONT BRAKE CALIPER

REF. NO.	PART NO.	DESCRIPTION	1P81	1P82	1P83	1P84	REMARKS
1	1C3-23466-00	CLAMP	1	1	1	1	
2	1C3-23467-00	CLAMP	1	1	1	1	
3	95707-06500	NUT, FLANGE	2	2	2	2	
4	5MV-2581T-00	DISK BRAKE ASSY	1	1	1	1	
5	90149-06327	SCREW	6	6	6	6	
6	1C3-2580T-00	CALIPER ASSY (LEFT)	1	1	1	1	
7	5UN-W0057-00	.PISTON ASSY, CALIPER	1	1	1	1	
8	3JD-W0047-00	..CALIPER SEAL KIT	1	1	1	1	
9	5DH-25919-00	.SUPPORT, PAD	1	1	1	1	
10	1UY-W0048-50	.BLEED SCREW KIT	1	1	1	1	
11	5MV-W0045-01	.BRAKE PAD KIT	1	1	1	1	
12	5DH-25933-00	.PIN, PAD	1	1	1	1	
13	5DH-25916-00	.PLUG	1	1	1	1	
14	3SP-25926-51	.BOLT	1	1	1	1	
15	3SP-25914-51	.PIN, SLIDE	1	1	1	1	
16	3JD-25917-00	.BOOT, CALIPER	1	1	1	1	
17	1UY-25937-51	.BOOT 2	1	1	1	1	
18	5DH-25849-00	.RETAINER, CALIPER	1	1	1	1	
19	90105-08659	BOLT, FLANGE	2	2	2	2	
20	1C3-25875-00	HOLDER, BRAKE HOSE 1	1	1	1	1	
21	95027-06010	BOLT, FLANGE	1	1	1	1	



5NY1100-A271

FIG. 27 REAR WHEEL

REF. NO.	PART NO.	DESCRIPTION	1P81	1P82	1P83	1P84	REMARKS
1	5ET-25311-00	HUB, REAR	1	1	1	1	
2	5ET-25317-00	SPACER, BEARING	1	1	1	1	
3	93306-27205	BEARING	1	1	1	1	
4	93306-07202	BEARING	1	1	1	1	
5	93106-30044	OIL SEAL	1	1	1	1	
6	93106-30045	OIL SEAL	1	1	1	1	
7	99009-45500	CIRCLIP	1	1	1	1	
8	94421-19602	RIM (2.15-19)	1	1	1	1	
9	5HD-25304-00	SPOKE SET, REAR	1	1	1	1	
10	94111-1913A	TIRE (110/90-19 62M D755)	1	1			DUNLOP FOR CAN
	94111-19012	TIRE (110/90-19 62M D739)	1			1	DUNLOP EXCEPT CAN
	94111-19011	TIRE (110/90-19 62M M602)			1		BRIDGESTONE
11	94211-19273	TUBE (110/90-19 M/C TR4)	1	1		1	DUNLOP
	94211-19274	TUBE (110/90-19 M/C TR4)				1	BRIDGESTONE
12	94311-19155	BAND, RIM (2.15-19)	1	1		1	DUNLOP
	94321-19157	BAND, RIM (2.15-19)				1	BRIDGESTONE
13	3JE-25394-00	SPACER, BEAD	1	1	1	1	
14	4XM-25364-00	DAMPER	1	1	1	1	
15	1C3-25449-00	SPROCKET, DRIVEN (49T)	1	1			UR STD FOR CAN
	1C3-25450-00	SPROCKET, DRIVEN (50T)	1		1	1	UR STD EXCEPT CAN
	1C3-25447-00	SPROCKET, DRIVEN (47T)	1	1	1	1	AP
	1C3-25448-00	SPROCKET, DRIVEN (48T)	1	1	1	1	AP
	1C3-25449-00	SPROCKET, DRIVEN (49T)	1		1	1	AP
	1C3-25450-00	SPROCKET, DRIVEN (50T)	1	1			AP
	1C3-25451-00	SPROCKET, DRIVEN (51T)	1	1	1	1	AP
	1C3-25452-00	SPROCKET, DRIVEN (52T)	1	1	1	1	AP
16	90109-081G1	BOLT	6	6	6	6	

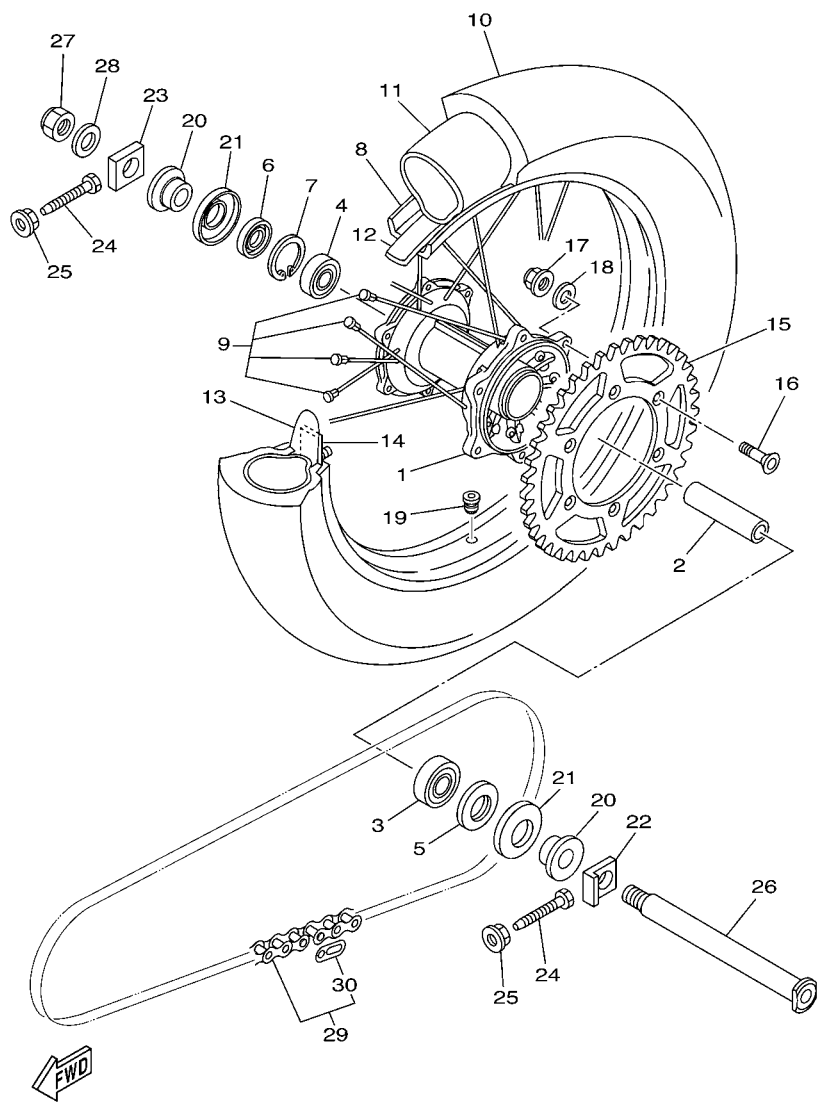

5NY1100-A271

FIG. 27 REAR WHEEL

REF. NO.	PART NO.	DESCRIPTION	1P81	1P82	1P83	1P84	REMARKS
17	90185-08169	NUT, SELF-LOCKING	6	6	6	6	
18	90201-08326	WASHER, PLATE	6	6	6	6	
19	90480-08608	GROMMET	1	1	1	1	
20	5UN-25383-00	COLLAR, WHEEL	2	2	2	2	
21	5ET-25367-00	COVER, HUB DUST	2	2	2	2	
22	1C3-25388-00	PULLER, CHAIN 1	1	1	1	1	
23	1C3-25389-00	PULLER, CHAIN 2	1	1	1	1	
24	90101-08777	BOLT	2	2	2	2	
25	90179-08299	NUT	2	2	2	2	
26	1C3-25381-00	AXLE, WHEEL	1	1	1	1	
27	90185-20168	NUT, SELF-LOCKING	1	1	1	1	
28	90201-203U1	WASHER, PLATE	1	1	1	1	
29	9Y581-92113	CHAIN (DID 520D 114L)	1	1	1	1	
30	94681-68001	.JOINT,CHAIN (DID 520DM-RJ)	1	1	1	1	

FIG. 28 REAR BRAKE CALIPER

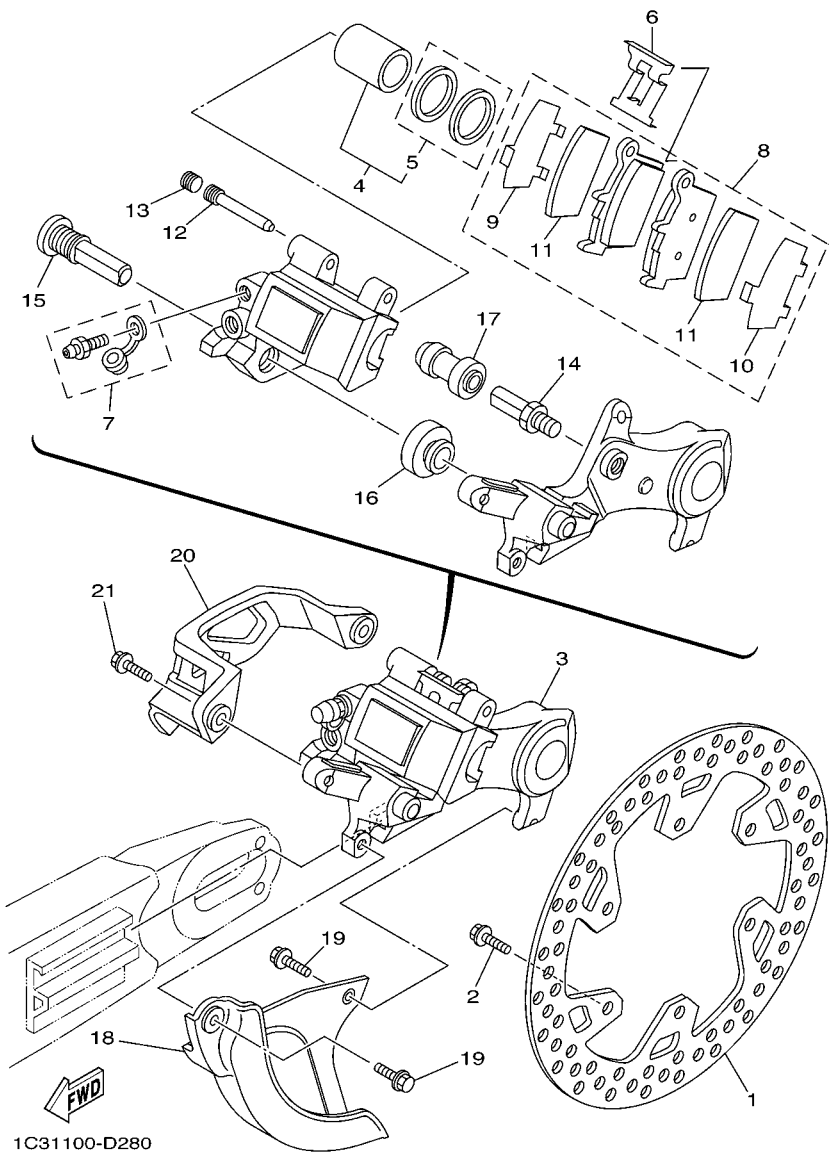

REF. NO.	PART NO.	DESCRIPTION	1P81	1P82	1P83	1P84	REMARKS
1	5NY-2582W-00	DISK, REAR BRAKE 2	1	1	1	1	
2	90109-065G4	BOLT	6	6	6	6	
3	1C3-2580W-10	CALIPER ASSY, REAR 2	1	1	1	1	
4	5UN-W0057-50	.PISTON ASSY, CALIPER	1	1	1	1	
5	5UN-W0047-50	..CALIPER SEAL KIT	1	1	1	1	
6	5DH-25919-50	..SUPPORT, PAD	1	1	1	1	
7	1UY-W0048-50	.BLEED SCREW KIT	1	1	1	1	
8	1C3-W0046-10	.BRAKE PAD KIT 2	1	1	1	1	
9	5UN-25828-60	..SHIM, CALIPER	1	1	1	1	
10	5UN-25827-60	..SHIM, CALIPER	1	1	1	1	
11	5UN-22898-60	..INSULATOR, HEAT	2	2	2	2	
12	8CR-25924-00	.PIN, PAD	1	1	1	1	
13	5DH-25916-00	.PLUG	1	1	1	1	
14	5UN-25914-00	.PIN, SLIDE	1	1	1	1	
15	5DH-25914-50	.PIN, SLIDE	1	1	1	1	
16	3JD-25917-00	.BOOT, CALIPER	1	1	1	1	
17	1UY-25937-51	.BOOT 2	1	1	1	1	
18	5DH-25718-01	PROTECTOR, DISK BRAKE	1	1	1	1	
19	95027-06012	BOLT, FLANGE	2	2	2	2	
20	5TA-27491-00	PROTECTOR	1	1	1	1	
21	95027-06016	BOLT, FLANGE	2	2	2	2	

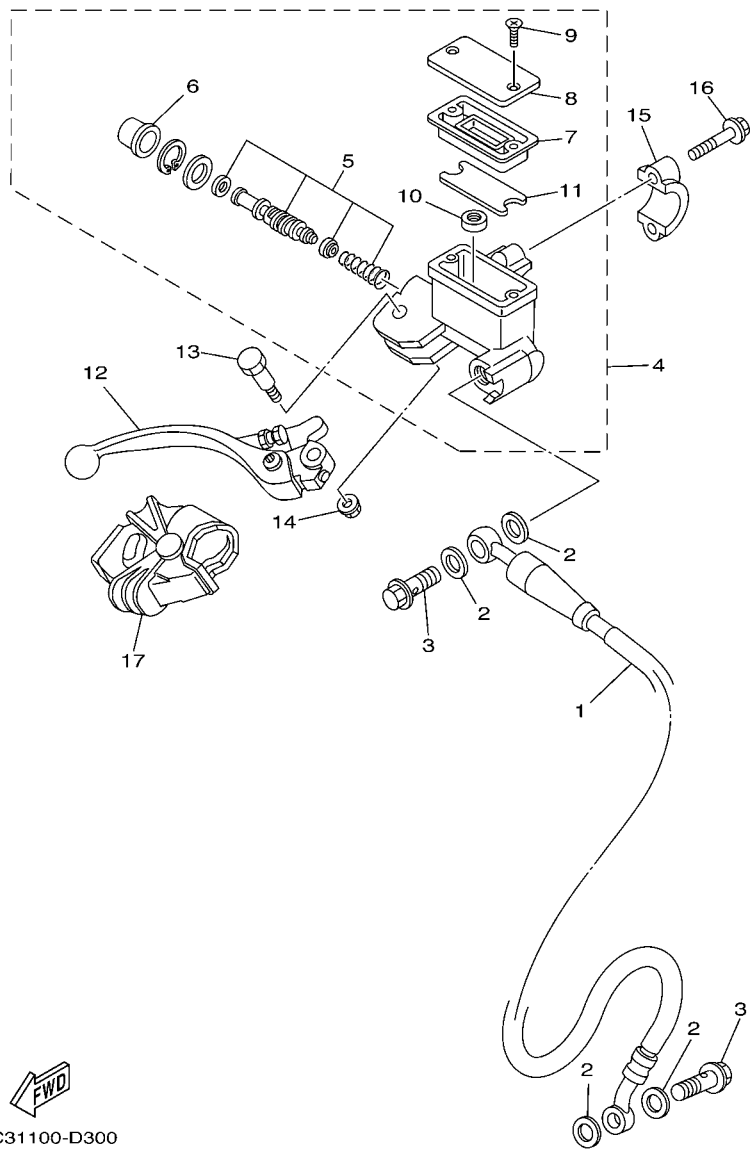



1C31100-D300

FIG. 30 FRONT MASTER CYLINDER

REF. NO.	PART NO.	DESCRIPTION	1P81	1P82	1P83	1P84	REMARKS
1	1C3-25872-00	HOSE, BRAKE 1	1	1	1	1	
2	90201-10118	WASHER, PLATE	4	4	4	4	
3	90401-10172	BOLT, UNION	2	2	2	2	
4	5XE-W2587-00	MASTER CYLINDER SUB ASSY	1	1	1	1	
5	5NY-W0041-00	.CYLINDER KIT, MASTER	1	1	1	1	
6	5NY-25868-00	.BOOT, MASTER CYLINDER	1	1	1	1	
7	5XE-25854-00	.DIAPHRAGM, RESERVOIR	1	1	1	1	
8	5MV-25852-01	.CAP, RESERVOIR	1	1	1	1	
9	98706-04012	.SCREW, FLAT HEAD	2	2	2	2	
10	5CG-25715-00	.SEPARATOR ASSY	1	1	1	1	
11	5XE-25853-00	.FLOAT, RESERVOIR	1	1	1	1	
12	5MV-83922-00	LEVER 2	1	1	1	1	
13	5MV-2589F-00	BOLT, LEVER	1	1	1	1	
14	95701-06500	NUT, FLANGE	1	1	1	1	
15	5MV-25867-00	BRACKET, MASTER CYLINDER	1	1	1	1	
16	5MV-25833-00	BOLT, FITTING	2	2	2	2	
17	5NY-26372-00	COVER, HANDLE LEVER 1	1	1	1	1	

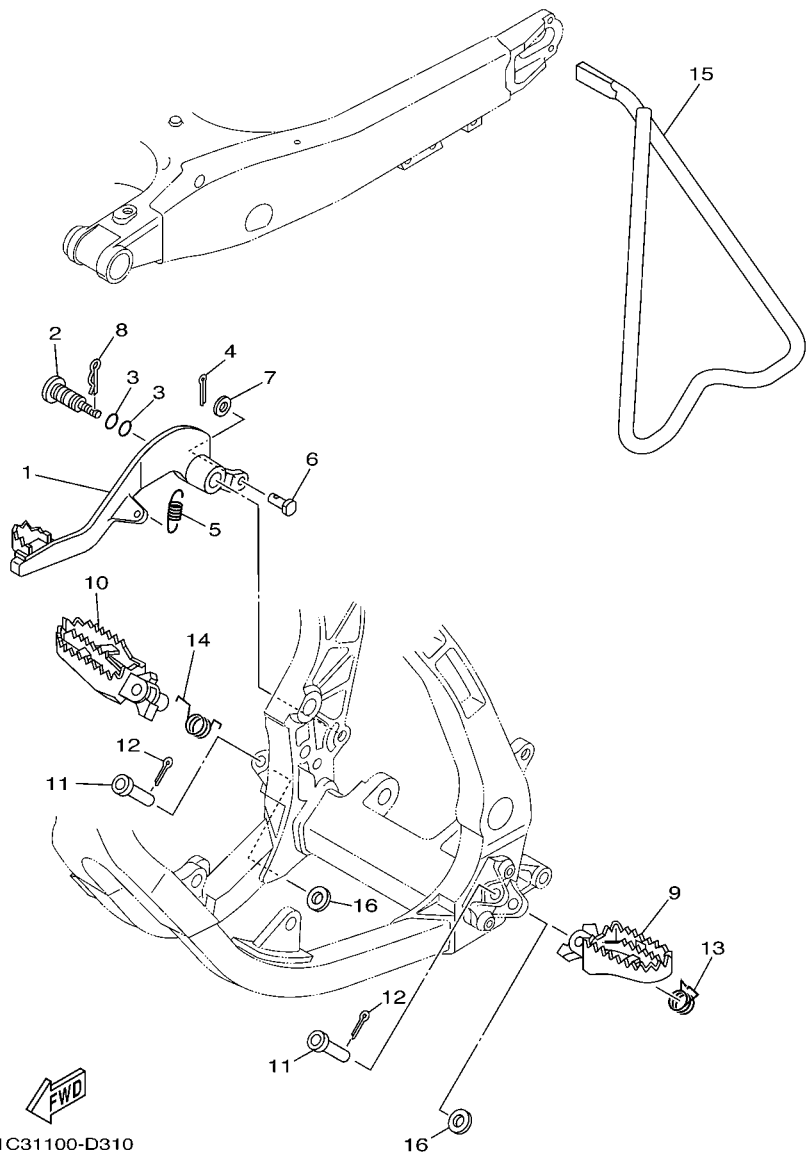
FIG. 31 STAND & FOOTREST



REF. NO.	PART NO.	DESCRIPTION	1P81	1P82	1P83	1P84	REMARKS
1	1C3-27200-00	PEDAL, BRAKE	1	1	1	1	
2	1C3-27217-00	BOLT	1	1	1	1	
3	93210-11073	O-RING	2	2	2	2	
4	91401-20012	PIN, COTTER	1	1	1	1	
5	90506-16500	SPRING, TENSION	1	1	1	1	
6	90240-08120	PIN, CLEVIS	1	1	1	1	
7	90201-08089	WASHER, PLATE	1	1	1	1	
8	90468-16099	CLIP	1	1	1	1	
9	5XE-27411-01	FOOTREST 1	1	1	1	1	
10	5XE-27421-01	FOOTREST 2	1	1	1	1	
11	90240-10142	PIN, CLEVIS	2	2	2	2	
12	91401-25015	PIN, COTTER	2	2	2	2	
13	90508-282B8	SPRING, TORSION	1	1	1	1	
14	90508-282B9	SPRING, TORSION	1	1	1	1	
15	1C3-27311-00	STAND, SIDE	1	1	1	1	
16	90201-10119	WASHER, PLATE	2	2	2	2	

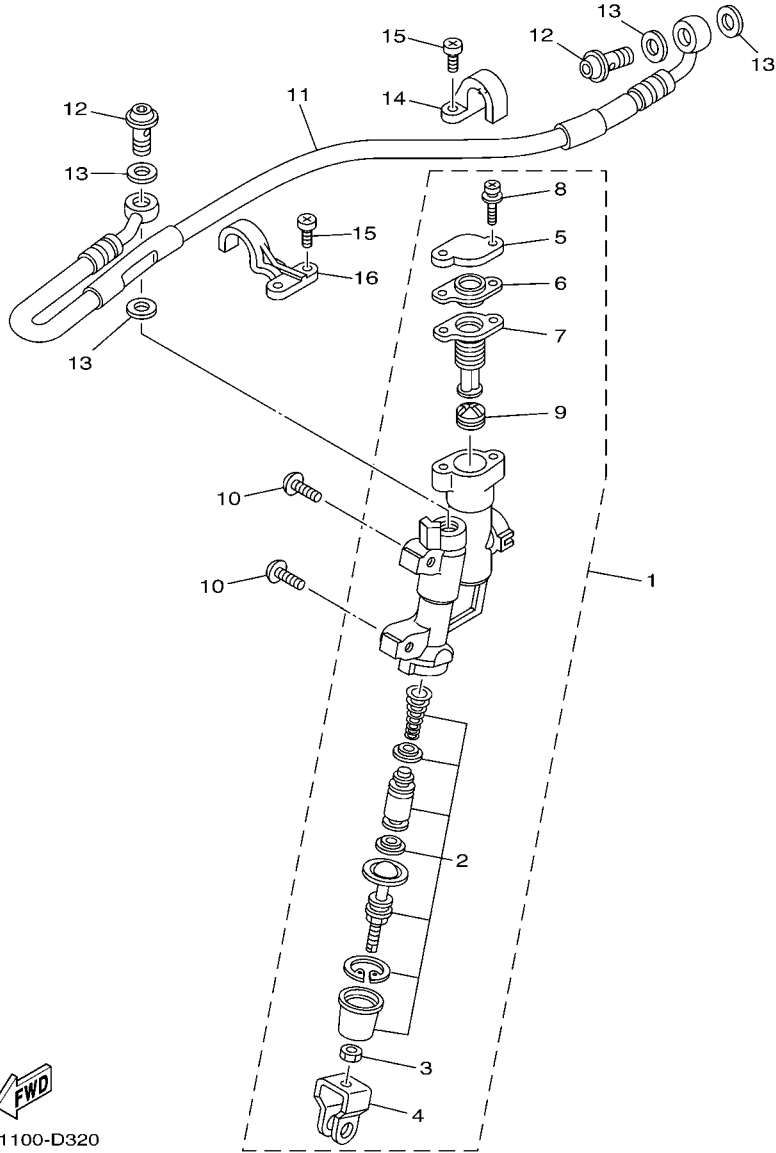

1C31100-D320

FIG. 32 REAR MASTER CYLINDER

REF. NO.	PART NO.	DESCRIPTION	1P81	1P82	1P83	1P84	REMARKS
1	1C3-2583V-00	RR. MASTER CYLINDER ASSY.	1	1	1	1	
2	5UN-W0042-50	.CYLINDER KIT, MASTER	1	1	1	1	
3	5UN-27218-00	.NUT	1	1	1	1	
4	5UN-27222-00	.JOINT	1	1	1	1	
5	5UN-25852-50	.CAP, RESERVOIR	1	1	1	1	
6	5UN-2585B-00	.PLATE, DIAPHRAGM	1	1	1	1	
7	5UN-25854-00	.DIAPHRAGM, RESERVOIR	1	1	1	1	
8	5UN-27217-00	.BOLT	2	2	2	2	
9	5CG-25715-00	.SEPARATOR ASSY	1	1	1	1	
10	90111-06029	BOLT	2	2	2	2	
11	1C3-25873-00	HOSE, BRAKE 2	1	1	1	1	
12	90401-10172	BOLT, UNION	2	2	2	2	
13	90201-10118	WASHER, PLATE	4	4	4	4	
14	2VM-25876-00	HOLDER, BRAKE HOSE 2	2	2	2	2	
15	98507-05010	SCREW, PAN HEAD	4	4	4	4	
16	1C3-25876-00	HOLDER, BRAKE HOSE 2	1	1	1	1	

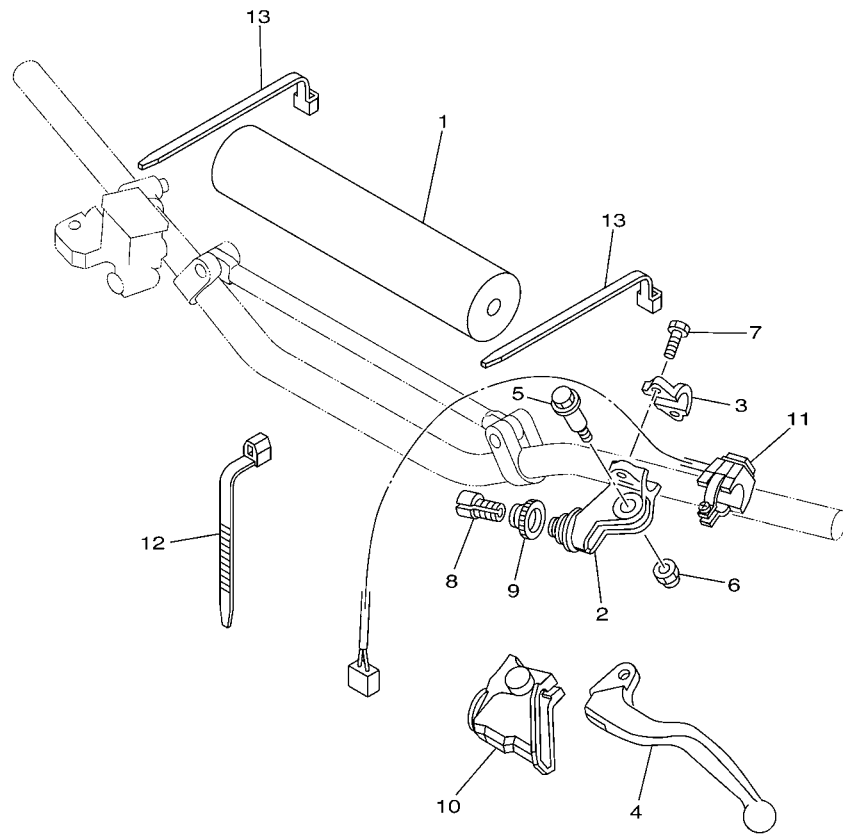
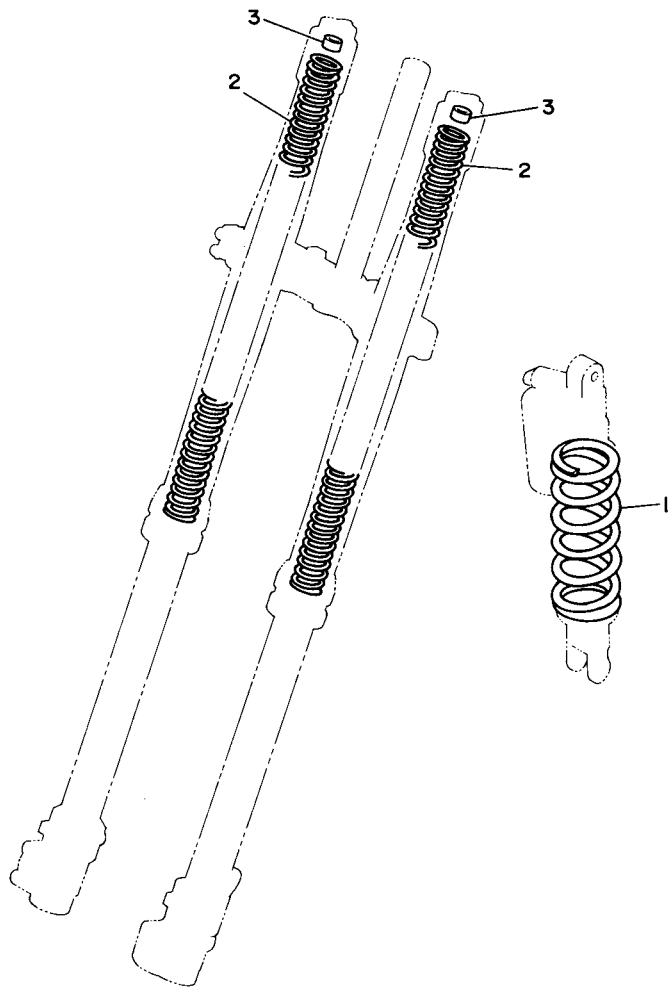

FIG. 34 HANDLE SWITCH & LEVER

REF. NO.	PART NO.	DESCRIPTION	1P81	1P82	1P83	1P84	REMARKS
1	1C3-26124-00	PROTECTOR, HANDLEBAR	1	1	1	1	
2	5XE-82911-00	HOLDER, LEVER 1	1	1	1	1	
3	5TG-82913-00	HOLDER, LEVER LOWER 1	1	1	1	1	
4	5MV-83912-00	LEVER 1	1	1	1	1	
5	90109-06034	BOLT	1	1	1	1	
6	5LP-84126-10	NUT, LENS FITTING	1	1	1	1	
7	90101-05033	BOLT	2	2	2	2	
8	5HD-26337-00	BOLT, ADJUSTING	1	1	1	1	
9	5HD-83951-00	BOLT, CABLE ADJUSTING	1	1	1	1	
10	5HD-26372-00	COVER, HANDLE LEVER 1	1	1	1	1	
11	1C3-83976-00	SWITCH, HANDLE 1	1	1	1	1	
12	90464-13077	CLAMP	3	3	3	3	
13	90464-15195	CLAMP	2	2	2	2	

FWD
1C31100-D340

FIG. 36 ALTERNATE FOR CHASSIS



3XJ1100-1360

REF. NO.	PART NO.	DESCRIPTION	1P81	1P82	1P83	1P84	REMARKS
1	5UN-22212-00	SPRING (K=42N/MM)	1	1	1	1	AP
	5UN-22212-10	SPRING (K=44N/MM)	1	1	1	1	AP
	5UN-22212-20	SPRING (K=46N/MM)	1	1	1	1	AP
	5UN-22212-40	SPRING (K=50N/MM)	1	1	1	1	AP
	5UN-22212-50	SPRING (K=52N/MM)	1	1	1	1	AP
	5UN-22212-60	SPRING (K=54N/MM)	1	1	1	1	AP
	5UN-22212-70	SPRING (K=56N/MM)	1	1	1	1	AP
	5UN-22212-A0	SPRING (K=APPROX.44N/MM)	1	1	1	1	AP
	5UN-22212-B0	SPRING (K=APPROX.46N/MM)	1	1	1	1	AP
	5UN-22212-C0	SPRING (K=APPROX.48N/MM)	1	1	1	1	AP
2	5UN-22212-D0	SPRING (K=APPROX.50N/MM)	1	1	1	1	AP
	5UN-22212-E0	SPRING (K=APPROX.52N/MM)	1	1	1	1	AP
	5UN-22212-F0	SPRING (K=APPROX.54N/MM)	1	1	1	1	AP
	5UN-22212-G0	SPRING (K=APPROX.56N/MM)	1	1	1	1	AP
	1C3-23141-00	SPRING (K=3.9N/MM)	2	2	2	2	AP
	1C3-23141-10	SPRING (K=4.0N/MM)	2	2	2	2	AP
	1C3-23141-20	SPRING (K=4.1N/MM)	2	2	2	2	AP
	1C3-23141-30	SPRING (K=4.2N/MM)	2	2	2	2	AP
3	1C3-23141-40	SPRING (K=4.3N/MM)	2	2	2	2	AP
	1C3-23141-50	SPRING (K=4.4N/MM)	2	2	2	2	AP
	1C3-23141-60	SPRING (K=4.5N/MM)	2	2	2	2	AP
	1C3-23141-70	SPRING (K=4.6N/MM)	2	2	2	2	AP
	1C3-23141-80	SPRING (K=4.7N/MM)	2	2	2	2	AP
	1C3-23364-00	COLLAR 2	1	1	1	1	UN

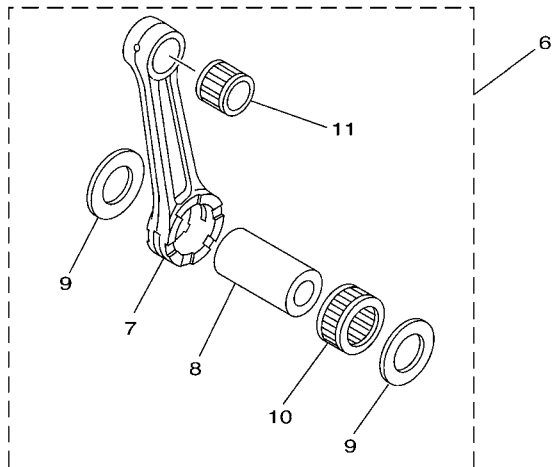
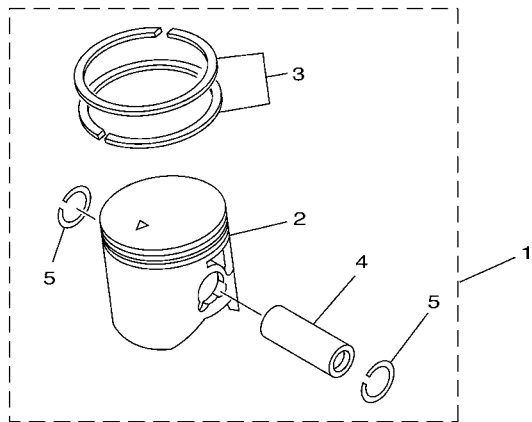

5MW1100-1370

FIG. 37 OPTIONAL PARTS 1

REF. NO.	PART NO.	DESCRIPTION	1P81	1P82	1P83	1P84	REMARKS
1	1P8-11630-00	PISTON ASSY (STD)	1	1	1	1	
2	1P8-11631-00-B0	.PISTON (STD)	1	1	1	1	ORANGE
3	5CU-11603-10	.PISTON RING SET (STD)	1	1	1	1	
4	5UP-11633-00	.PIN, PISTON	1	1	1	1	
5	93450-19052	.CIRCLIP	2	2	2	2	
6	5MW-11650-00	CONNECTING ROD ASSY	1	1	1	1	
7	5MW-11651-00	.ROD, CONNECTING	1	1	1	1	
8	5CU-11681-00	.PIN, CRANK 1	1	1	1	1	
9	90209-24327	.WASHER	2	2	2	2	
10	93310-52406	.BEARING	1	1	1	1	
11	93310-218A6	.BEARING	1	1	1	1	

NUMERICAL INDEX

PART NO.	GRID NO.	PART NO.	GRID NO.	PART NO.	GRID NO.	PART NO.	GRID NO.	PART NO.	GRID NO.	PART NO.	GRID NO.
5UP-11111-00	B - 2	5MW-12422-00	B - 6	4XM-14451-00	B - 8	4MX-14948-08	B - 9	5CU-17131-00	C - 4	1C3-2173F-00	C - 11
5MW-11111-01	B - 2	5XF-12428-00	B - 6	5NX-14453-00	B - 8	4MX-14948-09	B - 9	5BE-17141-30	C - 4	5XE-21740-00	C - 11
5UP-11311-00	B - 2	5DJ-12451-00	B - 6	5NY-14455-10	B - 8	4MX-14948-10	B - 9	5BE-17151-00	C - 4	5MV-2175C-00	C - 11
5XF-1131D-00	B - 2	5CU-12459-00	B - 6	3JD-14458-01	B - 8	4MX-14948-11	B - 9	5BE-17211-00	C - 4	1C3-22110-00	C - 12
5CU-1131E-00	B - 2	5NX-12461-00	B - 7	5NY-14459-00	B - 8	4MX-14948-12	B - 9	5JG-17221-10	C - 4	1C3-22121-00	C - 13
5CU-1131M-00	B - 3	5HD-12462-00	B - 7	676-14548-00	B - 10	4JT-1494F-03	B - 11	5BE-17231-00	C - 4	1C3-22122-00	C - 13
5CU-1131P-00	B - 2	1C3-12465-00	B - 7	4MX-14561-00	B - 9	4JT-1494F-07	B - 11	5JG-17241-00	C - 4	1C3-22128-00	C - 12
5CU-1131U-10	B - 2	5CU-12481-10	B - 7	5NX-14562-00	B - 11	4JT-1494F-09	B - 11	5BE-17251-10	C - 4	1C3-22141-00	C - 12
5CU-1131V-00	B - 3	5NY-12482-00	B - 7	1P8-14610-00	B - 12	4JT-1494F-11	B - 11	5BE-17402-00	C - 4	1C3-22151-00	C - 12
5CU-1132A-00	B - 2	1P8-12484-00	B - 7	1P8-14610-10	B - 12	4JT-1494F-13	B - 11	5BE-17411-00	C - 4	5UN-22176-00	C - 14
5MW-1132E-00	B - 3	353-13115-01	B - 3	3JE-14615-01	B - 12	4JT-14984-00	B - 9	5HC-17466-00	B - 14	30X-22178-00	C - 8
5MW-1132F-00	B - 3		B - 13	5MW-14642-00	B - 12	4SR-14985-00	B - 9	4L0-17471-00	B - 13	3JD-22178-20	C - 8
5UP-11351-00	B - 2	5NX-13565-00	B - 8	5CU-1469A-00	B - 12	5NX-15111-00	B - 13	5CU-18101-10	C - 7	1C3-2217A-00	C - 12
5CU-11354-00	B - 3	5NX-13610-00	B - 8	5HC-1469A-10	B - 12	4V4-15118-00	B - 13	1C3-18110-00	C - 7	1C3-2217F-00	C - 12
5NX-11395-00	B - 3	5NX-13613-00	B - 8	5NX-14753-01	B - 12	5CU-15118-00	B - 13	5MW-18122-01	C - 7	4V4-22184-00	C - 8
5UP-11400-00	B - 5	4XL-13616-00	B - 8	5NX-14753-11	B - 12	5NX-15121-00	B - 13	4BR-18127-10	C - 6	5MV-22184-00	C - 14
5UP-11410-00	B - 5	5XF-13622-00	B - 8	5CU-14771-01	B - 12	3Y1-15363-00	B - 14	5CU-18140-01	C - 6	1C3-22199-00	C - 12
5MW-11420-00	B - 5	5NX-13624-00	B - 8	5XF-14781-00	B - 12	4JT-15381-01	B - 13	5CU-18172-00	C - 7	1P8-22201-00	C - 14
5CU-11603-10	B - 5	4XL-13625-00	B - 8	4SR-14916-CJ	B - 10	5CU-15411-00	B - 14	3XJ-18173-00	C - 7	1P8-22201-10	C - 14
	E - 8	1P8-14101-00	B - 9	4SR-14916-EK	B - 9	5MW-15415-00	B - 14	3XJ-18178-00	C - 7	1P8-22201-20	C - 14
1P8-11630-00	E - 8	1P8-14101-10	B - 9	4SR-14916-EH	B - 10	1P8-15421-00	B - 14	3XJ-18182-00	C - 7	1P8-22201-30	C - 14
1P8-11631-00-A0	B - 5	1P8-14101-20	B - 9	4SR-14916-EJ	B - 9	5NX-15431-00	B - 14	3XJ-18184-00	C - 7	1P8-22201-40	C - 14
1P8-11631-00-B0	B - 5	4SR-14105-00	B - 10	4SR-14916-EK	B - 9	5CU-15451-00	B - 14	4EW-18185-00	C - 6	1P8-22210-00	C - 14
	E - 8	4XL-1410E-00	B - 11	4SR-14916-EW	B - 9	5CU-15454-00	B - 13	5BE-18501-20	C - 6	1P8-22210-10	C - 14
1P8-11631-00-C0	B - 5	5NX-1410H-00	B - 11	4SR-14916-RH	B - 10	5CU-15462-00	B - 14	5BE-18502-20	C - 6	1P8-22210-20	C - 14
1P8-11631-00-D0	B - 5	4MX-14115-00	B - 9	4SR-14916-RJ	B - 10	5CU-15463-00	B - 14	5CU-18503-20	C - 6	1P8-22210-30	C - 14
5UP-11633-00	B - 5	5HC-14126-00	B - 10	4SR-14916-RW	B - 10	5NX-15601-10	B - 15	5MW-18541-00	C - 6	1P8-22210-40	C - 14
	E - 8	5HC-14131-00	B - 10	4MX-14919-00	B - 10	5NX-15620-10	B - 15	5DH-18562-00	C - 6	5UN-22212-00	E - 7
5MW-11650-00	E - 8	3TJ-14137-40	B - 10	5HC-14922-00	B - 11	5NX-15621-10	B - 15	1P8-21101-00	C - 8	5UN-22212-10	E - 7
5MW-11651-00	B - 5	4XL-14146-00	B - 9	5HC-14934-00	B - 11	5CU-15651-00	B - 15	1C3-21190-00	C - 8	5UN-22212-20	E - 7
	E - 8	5HC-14146-00	B - 11	4MX-14943-40	B - 10	5NL-15664-00	B - 15	1C3-21244-00	C - 9	5UN-22212-30	C - 14
5CU-11681-00	B - 5	4JT-14147-00	B - 11	4MX-14943-41	B - 10	4GY-15671-00	B - 15	1C3-2135F-00	C - 13	5UN-22212-40	E - 7
	E - 8	663-14159-00	B - 10	4MX-14943-42	B - 10	214-15674-00	B - 15	1C3-2139R-00	C - 13	5UN-22212-50	E - 7
5CU-11830-00	B - 3	4JT-14171-00	B - 9	4MX-14943-43	B - 10	214-15686-00	B - 15	5NX-21425-00	C - 8	5UN-22212-60	E - 7
4SS-11832-00	B - 3	4MX-14194-00	B - 11	4MX-14943-44	B - 11	5DJ-16111-00	C - 2	5HD-21511-00	C - 10	5UN-22212-70	E - 7
5CU-11911-00	B - 4	4XL-14196-10	B - 10	4MX-14943-45	B - 11	5MW-16113-00	C - 2	5UN-2153A-00	C - 13	5UN-22212-A0	E - 7
5CU-11912-00	B - 4	4XL-14197-10	B - 10	4MX-14943-90	B - 10	5DJ-16150-00	C - 2	4XL-2153A-10	D - 4	5UN-22212-B0	E - 7
4JY-11915-01	B - 4	1P8-14208-00	B - 11	4MX-14943-91	B - 10	2K7-16154-00	C - 2	4ES-2153E-01	C - 10	5UN-22212-C0	E - 7
5X4-11921-02	B - 4	5HC-14216-00	B - 11	4MX-14943-92	B - 10	5CU-16154-00	C - 2	5XE-21610-00	C - 10	5UN-22212-D0	E - 7
3JE-11922-01	B - 4	5NX-14216-00	B - 11	4MX-14943-93	B - 10	2VM-16181-00	C - 2	5XE-21635-00	C - 10	5UN-22212-E0	E - 7
5CU-11952-00	B - 4	5HC-14261-00	B - 10	4MX-14943-94	B - 11	3XK-16321-00	C - 2	5XF-2163G-00	C - 10	5UN-22212-F0	E - 7
5NY-11953-00	B - 4	5HC-14264-00	B - 11	4MX-14943-95	B - 11	4X7-16325-00	C - 2	5UN-21642-00	C - 10	5UN-22212-G0	E - 7
5CU-11956-00	C - 2	5HC-14275-00	B - 11	4MX-14948-02	B - 9	5JG-16351-00	C - 2	5NY-21711-00	C - 11	3SP-22213-00	C - 14
5CU-11990-00	B - 4	5HC-14340-A7	B - 10	4MX-14948-03	B - 9	4XL-16356-00	C - 2	5GJ-21717-00	C - 8	5XE-22214-00	C - 14
5CU-11991-00	B - 3	4MX-14392-00	B - 9	4MX-14948-04	B - 9	1P8-16357-00	C - 2	5NY-21721-00	C - 11	5MV-22224-00	C - 14
5CU-11993-00	B - 3	5NY-14401-01	B - 8	4MX-14948-05	B - 9	5NX-16371-00	C - 2	5NL-2172A-11	C - 11	4JX-22226-00	C - 14
5CU-11995-00	B - 3	5NY-14417-00	B - 8	4MX-14948-06	B - 9	5CU-16380-10	C - 2	5XE-21730-00	C - 11	3SP-22234-00	C - 14
5NX-1240A-00	B - 7	5NY-14442-00	B - 8	4MX-14948-07	B - 9	5JG-17121-10	C - 4	1C3-2173E-00	C - 11	5NY-22241-00	C - 15

NUMERICAL INDEX

PART NO.	GRID NO.	PART NO.	GRID NO.	PART NO.	GRID NO.	PART NO.	GRID NO.	PART NO.	GRID NO.	PART NO.	GRID NO.
5XE-22242-00	C - 14	5TJ-2319U-00	D - 2	5SF-25394-00	D - 9	1C3-26124-00	E - 5	1C3-W0046-10	D - 13	90159-06010	C - 2
1C3-22253-00	C - 14	1P8-23340-L0	D - 4	1C3-25447-00	D - 11	4XM-26240-00	D - 14	3JD-W0047-00	D - 10	90159-06078	C - 11
5MV-22253-00	C - 14	5NY-23346-L0	D - 4	1C3-25448-00	D - 11	4GY-26241-00	D - 14	5UN-W0047-50	D - 13	90170-20255	C - 2
1P8-22355-00	C - 12	3SP-23356-L0	D - 5	1C3-25449-00	D - 11	4GY-26242-00	D - 14	1UY-W0048-50	D - 10	90176-08026	B - 2
4EW-22474-00	C - 14	5TA-23357-00	D - 2	1C3-25450-00	D - 11	4XM-26243-00	D - 14		D - 13	90179-06568	C - 12
3JE-22475-00	C - 14	1C3-23364-00	E - 7	1C3-25451-00	D - 11	4SS-26256-00	D - 14	5UN-W0057-00	D - 10	90179-08299	D - 12
5NY-22475-00	C - 14	5XE-23389-00	D - 4	1C3-25452-00	D - 11	4SS-26259-00	D - 14	5UN-W0057-50	D - 13	90179-08674	C - 8
5UN-22898-60	D - 13	4EW-23416-00	D - 2	5CG-25715-00	D - 15	5NY-26273-00	D - 14	5XE-W2587-00	D - 15	90179-10658	C - 8
1C3-22969-00	C - 12	5XE-23435-20	D - 2		E - 3	4SS-26281-00	D - 14	90101-05033	E - 5	90179-10M35	B - 2
1P8-23102-00	D - 3	5XE-23441-00	D - 2	5DH-25718-01	D - 13	4SS-26282-10	D - 14	90101-06034	C - 7	90179-12248	E - 4
1P8-23103-00	D - 3	1C3-23466-00	D - 10	1C3-2580T-00	D - 10	4SS-26287-01	D - 14	90101-08777	D - 12	90179-16002	D - 9
1P8-23110-L0	D - 3	1C3-23467-00	D - 10	1C3-2580W-10	D - 13	4SS-2628H-00	D - 14	90105-05002	B - 4	90179-20255	C - 5
1C3-23111-L0	D - 3	1C3-23485-00	D - 2	5MV-2581T-00	D - 10	5HC-26311-00	D - 14	90105-06045	C - 10	90179-28003	D - 2
5XE-23113-00	D - 4	1C3-24110-00	D - 6	5UN-25827-60	D - 13	4SS-2632G-00	D - 14	90105-06046	C - 10	90183-06023	B - 8
276-23114-00	D - 3	4EW-2412F-00	D - 6	5UN-25828-60	D - 13	1P8-26335-00	D - 14	90105-06055	C - 11	90185-08055	C - 8
1C3-23118-L0	D - 3	5XE-24144-00	D - 6	5NY-2582W-00	D - 13	5HD-26337-00	E - 5	90105-06553	C - 6	90185-08169	D - 12
1P8-23120-L0	D - 3	3SP-24173-00	D - 6	5MV-25833-00	D - 15	5HD-26342-00	D - 14	90105-06556	B - 13	90185-10060	C - 15
5XE-23125-L0	D - 3	5XE-24176-00	D - 6	1C3-2583V-00	E - 3	5HD-26372-00	E - 5	90105-08057	C - 8	90185-14007	C - 13
1C3-23136-L0	D - 3	1C3-24181-00	D - 6	5DH-25849-00	D - 10	5NY-26372-00	D - 15	90105-08059	C - 8	90185-16127	C - 12
1C3-23141-00	E - 7	1P8-24182-00	D - 6	5MV-25852-01	D - 15	1C3-27200-00	E - 2	90105-08120	C - 8	90185-20168	D - 12
1C3-23141-10	E - 7	1C3-24183-00	D - 6	5UN-25852-50	E - 3	1C3-27217-00	E - 2	90105-08659	D - 10	90201-03313	B - 8
1C3-23141-20	E - 7	1C3-24184-00	D - 7	5XE-25853-00	D - 15	5UN-27217-00	E - 3	90105-10074	C - 8	90201-057H5	B - 2
1C3-23141-30	E - 7	5NY-24186-00	D - 6	5UN-25854-00	E - 3	5UN-27218-00	E - 3	90105-10079	C - 8		B - 4
1C3-23141-40	E - 7	1C3-24240-00	D - 6	5XE-25854-00	D - 15	5UN-27222-00	E - 3	90105-10445	C - 2	90201-06013	C - 6
1C3-23141-50	E - 7	3XJ-24380-00	D - 6	5UN-2585B-00	E - 3	1C3-27311-00	E - 2	90105-10733	C - 8	90201-06071	B - 12
1C3-23141-60	E - 7	3JD-24500-02	D - 6	5MV-25867-00	D - 15	5XE-27411-01	E - 2	90109-05001	B - 2		C - 10
1C3-23141-70	E - 7	4X8-24512-00	D - 6	5NY-25868-00	D - 15	5XE-27421-01	E - 2	90109-056G0	C - 2	90201-062A8	C - 10
1C3-23141-80	E - 7	3AJ-24534-01	D - 6	1C3-25872-00	D - 15	5TA-27491-00	D - 13	90109-06034	E - 5	90201-06557	C - 10
1P8-23141-L0	D - 3	5NY-24610-00	D - 6	1C3-25873-00	E - 3	5ET-28166-00	C - 9	90109-065G4	D - 13	90201-06571	B - 7
5XE-23144-L0	D - 3	5XE-2470F-00	D - 8	1C3-25875-00	D - 10	1P8-82310-00	E - 6	90109-066G1	C - 6	90201-08039	C - 8
1C3-23145-L0	D - 3	5NY-24728-00	D - 8	1C3-25876-00	E - 3	1P8-8231U-00	E - 6	90109-067F4	B - 8	90201-08089	E - 2
5XE-23146-L0	D - 3	5XE-24770-00	D - 8	2VM-25876-00	E - 3	8DG-82370-00	E - 6	90109-081G1	D - 11	90201-080L8	B - 2
1C3-23147-L0	D - 3	5NY-25104-00	D - 9	5MV-2589F-00	D - 15	1P8-82509-00	E - 6	90109-085E2	B - 15	90201-081G0	B - 3
1C3-2314F-L0	D - 3	5NY-25111-00	D - 9	5UN-25914-00	D - 13	5XE-82911-00	E - 5	90111-06029	E - 3	90201-08326	B - 15
1C3-2314H-00	D - 5	5NY-25117-00	D - 9	5DH-25914-50	D - 13	5TG-82913-00	E - 5	90116-08394	B - 2		D - 12
1C3-2314J-00	D - 4	1C3-25181-00	D - 9	3SP-25914-51	D - 10	5MV-83912-00	E - 5	90116-10314	B - 2	90201-08512	B - 6
5XE-23153-L0	D - 3	5NY-25183-00	D - 9	5DH-25916-00	D - 10	5MV-83922-00	D - 15	90119-06096	C - 10	90201-086P8	C - 8
2HH-23158-L0	D - 3	5NY-25186-00	D - 9		D - 13	5HD-83951-00	E - 5	90119-06192	B - 12	90201-08730	B - 12
1P8-2316A-L0	D - 3	5HD-25304-00	D - 11	3JD-25917-00	D - 10	1C3-83976-00	E - 5	90119-06225	C - 10		C - 8
1C3-2316E-L0	D - 3	5ET-25311-00	D - 11		D - 13	5LP-84126-10	E - 5	90119-08238	C - 11	90201-08784	B - 6
1C3-23170-L0	D - 3	5ET-25317-00	D - 11	5DH-25919-00	D - 10	5NX-85540-01	E - 6	90122-06035	B - 8	90201-10118	D - 15
5XE-23171-L0	D - 3	4XM-25364-00	D - 11	5DH-25919-50	D - 13	1P8-85546-00	E - 6	90149-06011	D - 6		E - 3
5DH-23183-00	C - 14	5ET-25367-00	D - 12	8CR-25924-00	D - 13	5UP-85550-00	E - 4		E - 4	90201-10119	E - 2
509-23184-L0	C - 14	1C3-25381-00	D - 12	3SP-25926-51	D - 10	5CU-85560-10	E - 4	90149-06326	B - 13	90201-105P3	C - 2
5UX-23188-00	D - 3	5UN-25383-00	D - 12	5DH-25933-00	D - 10	5NX-85885-00	B - 11	90149-06327	D - 10	90201-12575	C - 7
43F-23188-10	D - 3	1C3-25388-00	D - 12	1UY-25937-51	D - 10	5NY-W0041-00	D - 15	90151-04001	C - 12	90201-125L6	C - 2
1C3-23188-L0	D - 3	1C3-25389-00	D - 12		D - 13	5UN-W0042-50	E - 3	90152-06010	B - 15	90201-12688	E - 4
1C3-23188-M0	D - 3	3JE-25394-00	D - 11	1C3-26111-00	D - 14	5MV-W0045-01	D - 10	90157-06077	B - 13	90201-14740	C - 13

NUMERICAL INDEX

PART NO.	GRID NO.	PART NO.	GRID NO.	PART NO.	GRID NO.	PART NO.	GRID NO.	PART NO.	GRID NO.	PART NO.	GRID NO.
90201-150U6	B - 4	90430-06014	B - 14	92017-06010	B - 12	93310-52406	B - 5	95027-06012	D - 13	99009-20400	B - 15
90201-160F6	C - 12	90430-12227	B - 13	92907-03100	B - 8		E - 8	95027-06014	D - 2	99009-45500	D - 11
90201-162H4	B - 15	90445-08376	B - 13	92907-05600	B - 3	93315-11206	C - 2	95027-06016	D - 6	99530-08016	B - 14
90201-167P7	B - 15	90445-09025	D - 6	92907-06100	D - 8	93315-32165	C - 12		D - 13	99590-14016	B - 2
90201-20276	B - 15	90445-09220	D - 6	92907-06600	B - 14	93315-32166	C - 12	95027-06020	C - 7	9Y581-92113	D - 12
90201-203U1	D - 12	90445-09777	B - 3	92907-10200	C - 8	93317-22262	C - 12		D - 4		
90201-20685	B - 15	90445-111J0	D - 6		C - 15	93332-00068	D - 2		E - 6		
90201-21013	C - 12	90450-25037	B - 7	93102-12106	B - 6	93332-00081	D - 4	95027-06025	B - 6		
90201-247L2	D - 2	90450-28014	B - 7	93102-12224	C - 2	93340-21505	B - 4		B - 7		
90201-253K0	C - 4	90450-51070	B - 8		C - 7		C - 2		B - 12		
90201-286K9	D - 2	90450-70072	B - 8	93102-18278	B - 15	93342-22217	C - 12		B - 14		
90202-05193	D - 6	90464-06214	B - 8	93102-20485	B - 5	93410-20038	B - 15		D - 14		
90209-06096	B - 8	90464-13077	E - 5	93102-26468	D - 9	93440-10085	C - 2	95027-06030	B - 14		
90209-16008	C - 12	90464-15195	E - 5	93102-28004	B - 5	93440-25084	C - 4	95027-06050	B - 14		
90209-21332	C - 4	90464-48001	E - 6	93102-32337	C - 4	93440-28062	C - 4		C - 12		
90209-24327	B - 5	90465-13275	D - 6	93104-08040	B - 3	93450-19052	B - 5	95027-06065	B - 6		
	E - 8		E - 6		B - 4		E - 8		B - 14		
90209-26348	C - 4	90467-09006	B - 7	93106-22019	C - 12	93507-16020	B - 4	95027-08035	B - 12		
90215-20231	C - 2	90467-10008	D - 6	93106-30044	D - 11	93507-32009	B - 15		D - 2		
90215-21256	C - 5	90468-16099	E - 2	93106-30045	D - 11	93603-14240	B - 4	95027-08040	C - 8		
90240-08120	E - 2	90480-08608	D - 12	93109-11073	B - 6	93604-08071	B - 2		D - 2		
90240-10142	E - 2	90480-15528	B - 7	93109-21001	C - 13	93604-10011	B - 6	95027-08055	C - 8		
90267-32070	B - 8	90480-16404	B - 12	93109-25001	C - 12	93604-29184	B - 4	95607-10200	C - 14		
90280-03017	B - 5	90480-16561	B - 12	93109-28043	C - 12	93612-16254	B - 13	95617-10660	B - 2		
90340-12059	B - 13	90480-18549	D - 6	93210-06001	D - 14	9383E-13144	C - 5	95701-06500	D - 15		
90387-06009	C - 10	90501-046L6	B - 3	93210-11073	E - 2	9383E-14215	C - 5	95707-06500	D - 10		
90387-06039	B - 12	90501-052G5	C - 7	93210-15639	B - 2	94108-21012	D - 9	95827-06010	B - 7		
90387-06065	B - 7	90501-147A5	B - 15	93210-17570	B - 15	94108-21015	D - 9	95827-06016	C - 11		
90387-06090	C - 10	90501-16016	B - 15	93210-19123	B - 14	94108-2112Y	D - 9	97007-05020	B - 3		
90387-063G3	B - 12	90501-237L0	C - 2	93210-22298	C - 4	94111-19011	D - 11	97027-06016	B - 15		
90387-08027	C - 8	90501-256L2	B - 4	93210-74316	B - 2	94111-19012	D - 11	97307-06012	D - 8		
90387-08030	B - 12	90506-16500	E - 2	93211-02703	B - 2	94111-1913A	D - 11	97707-60016	C - 10		
90387-085E1	B - 4	90507-14064	C - 6	93300-60801	B - 4	94209-21229	D - 9	98502-04012	B - 11		
90387-086N4	C - 8	90507-20052	B - 12	93300-60804	C - 8	94211-19273	D - 11	98502-04014	B - 10		
90387-124F4	C - 7	90508-155B8	B - 3	93306-00105	B - 6	94211-19274	D - 11	98507-03008	B - 8		
90387-14005	C - 13	90508-282B8	E - 2	93306-00426	C - 4	94227-21101	D - 9		D - 6		
90387-152F2	B - 4	90508-282B9	E - 2	93306-00442	C - 4	94309-21161	D - 9	98507-05010	E - 3		
90387-16010	C - 12	90508-291A8	C - 7	93306-07202	D - 11	94311-19155	D - 11	98507-05012	B - 2		
90387-18004	C - 12	90508-30743	B - 15	93306-20540	C - 4	94321-19157	D - 11	98507-06030	B - 14		
90387-18007	B - 13	91317-04006	B - 4	93306-20574	C - 4	94330-21084	D - 9	98580-04006	B - 11		
90387-18009	C - 12	91317-04008	B - 3	93306-27205	D - 11	94416-21003	D - 9	98706-04012	D - 15		
90387-2113G	C - 4	91317-06025	B - 8	93306-37808	B - 5	94421-19602	D - 11	98707-06025	D - 6		
90387-227H7	D - 14	91317-06050	B - 13	93306-90403	D - 9	94681-68001	D - 12	98907-05012	B - 3		
90387-2515B	C - 4	91317-06060	B - 13	93306-90501	C - 6	94702-00326	B - 2		B - 4		
90401-10172	D - 15	91317-06070	B - 13	93306-90506	C - 6	94709-00326	B - 2	98907-05016	B - 3		
	E - 3	91401-20012	E - 2	93310-218A6	B - 5	95027-06010	B - 14	98907-06025	D - 6		
90430-05242	C - 3	91401-25015	E - 2		E - 8		C - 12	99001-06600	B - 6		
90430-06014	B - 6	91A20-05065	B - 7	93310-230T7	C - 2		D - 10	99009-16400	B - 15		