



# PARTS CATALOGUE

**YZ250FB** (17D9) CANADA

**YZ250F** (17DA) EUROPE

**YZ250F** (17DB) JAPAN

**YZ250FB** (17DC) OCEANIA, SOUTH AFRICA

YZ250FB/YZ250F  
PARTS CATALOGUE  
©2011 by Yamaha Motor Co., Ltd.  
1st edition, June 2011  
All rights reserved.  
Any reprinting or unauthorized use  
without the written permission of  
Yamaha Motor Co., Ltd.  
is expressly prohibited.  
Printed in Japan.

# FOREWORD

This Parts Catalogue is related to the parts for the model(s) on the cover page. When you are ordering replacement parts, please refer to this Parts Catalogue and quote both part numbers and part names correctly.

1. Modifications or additions which have been made after the issue of the Parts Catalogue will be announced in the Parts News.

It is advisable that you make the necessary corrections to the Parts Catalogue according to the Parts News.

2. Abbreviations

The following abbreviations are used in this Parts Catalogue.

“UR” Use specified parts number.

“UN” Use as many as needed.

“AP” Alternate Parts

“LM” Locally Made (Parts need to be ordered locally)

“F#” Frame No. (Applicable machine No.)

“O/S” Over Size

3. The number of components for assembly

- Parts, which are to be supplied in an assembly, are listed with a dot (.) in front of the part name as shown below.
- The numeral appearing to the right of each component part indicates the quantity of parts for each assembly unit.

PART NO.	DESCRIPTION	Q'TY	REMARKS
2F5-83310-60	FRONT FLASHER LIGHT ASSY	2	
115-83311-60	.BULB (6V-18W)	1	

4. Applicable colours of graphics are represented in the “REMARKS” as shown below.

PART NO.	DESCRIPTION	Q'TY	REMARKS
2N4-24110-00-X5	FUEL TANK COMP.	2	MXR
3J1-24240-10	.GRAPHIC, FUEL TANK	1	FOR MXR

5. Note that the illustrations for reference in finding parts numbers are not to be used for assembling. When assembling, please use the applicable service manual.

6. The asterisk (\*) before a reference number indicates modified items after the first edition.





# CONTENTS

## ENGINE

CYLINDER .....	1
CRANKSHAFT & PISTON .....	3
VALVE .....	4
CAMSHAFT & CHAIN .....	6
WATER PUMP .....	7
RADIATOR & HOSE .....	8
OIL PUMP .....	9
OIL CLEANER .....	11
INTAKE .....	12
CARBURETOR .....	13
EXHAUST .....	17
CRANKCASE .....	18
CRANKCASE COVER 1 .....	19
STARTER .....	21
CLUTCH .....	22
TRANSMISSION .....	23
SHIFT CAM & FORK .....	25
SHIFT SHAFT .....	26

## CHASSIS

FRAME .....	27
FENDER .....	29
SIDE COVER & OIL TANK .....	30
REAR ARM .....	32
REAR SUSPENSION .....	34
STEERING .....	36
FRONT FORK .....	37
FUEL TANK .....	40
SEAT .....	41
FRONT WHEEL .....	42
FRONT BRAKE CALIPER .....	43
REAR WHEEL .....	44
REAR BRAKE CALIPER .....	46
STEERING HANDLE & CABLE .....	47
FRONT MASTER CYLINDER .....	48
STAND & FOOTREST .....	49
REAR MASTER CYLINDER .....	50
GENERATOR .....	51
HANDLE SWITCH & LEVER .....	52
ELECTRICAL 1 .....	53
ALTERNATE FOR CHASSIS .....	54

## INDEX

NUMERICAL INDEX .....	55
-----------------------	----

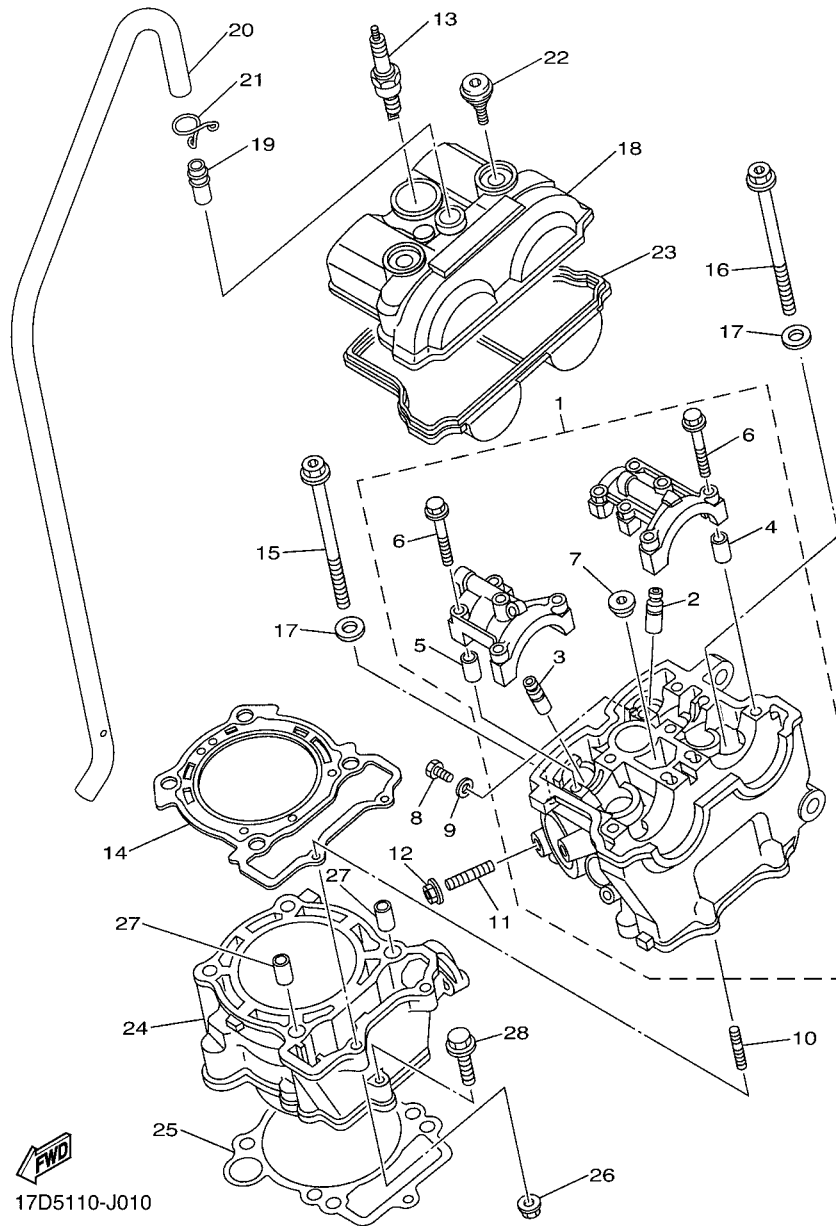

17D5110-J010

FIG. 1 CYLINDER

REF. NO.	PART NO.	DESCRIPTION	17D9	17DA	17DB	17DC	REMARKS
1	17D-11102-11	CYLINDER HEAD ASSY	1	1	1	1	
2	5XC-11133-10	.GUIDE, VALVE 1	3	3	3	3	
3	5NL-11134-10	.GUIDE, VALVE 2	2	2	2	2	
4	91808-16023	.PIN, DOWEL	2	2	2	2	
5	91808-16023	.PIN, DOWEL	2	2	2	2	
6	90105-06027	.BOLT, FLANGE	10	10	10	10	
7	90340-12007	.PLUG, STRAIGHT SCREW	1	1	1	1	
8	95022-06010	BOLT, FLANGE	1	1	1	1	
9	90430-06014	GASKET	1	1	1	1	
10	90116-06038	BOLT, STUD	2	2	2	2	
11	95612-08620	BOLT, STUD	2	2	2	2	
12	95702-08500	NUT, FLANGE	2	2	2	2	
13	94701-00411	PLUG, SPARK (NGK R CR8E)	1	1		1	STD
	94703-00411	PLUG, SPARK (NGK R CR8E)			1		STD
	94701-00410	PLUG, SPARK (NGK R CR9E)	1	1		1	AP
	94703-00410	PLUG, SPARK (NGK R CR9E)			1		AP
14	5NL-11181-00	GASKET, CYLINDER HEAD 1	1	1	1	1	
15	90105-09004	BOLT, FLANGE	2	2	2	2	
16	90105-09002	BOLT, FLANGE	2	2	2	2	
17	90201-096J9	WASHER, PLATE	4	4	4	4	
18	5NL-11191-50	COVER, CYLINDER HEAD 1	1	1	1	1	
19	371-11167-01	PIPE, BREATHER 2	1	1	1	1	
20	5XC-11166-00	PIPE, BREATHER 1	1	1	1	1	
21	90467-140A4	CLIP	1	1	1	1	
22	5UM-1119E-00	BOLT, COVER HEAD	2	2	2	2	
23	5NL-11193-00	GASKET, HEAD COVER 1	1	1	1	1	
24	5XC-11311-10	CYLINDER 1	1	1	1	1	

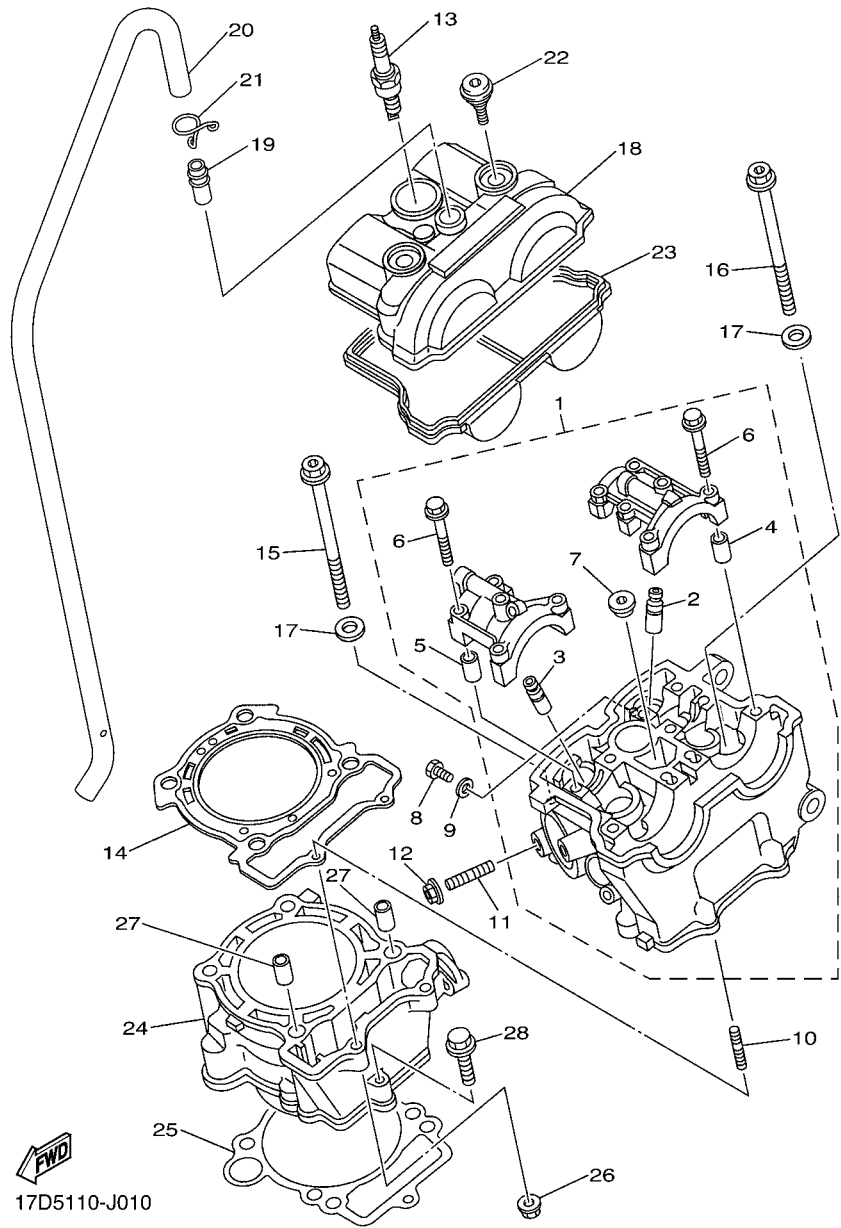
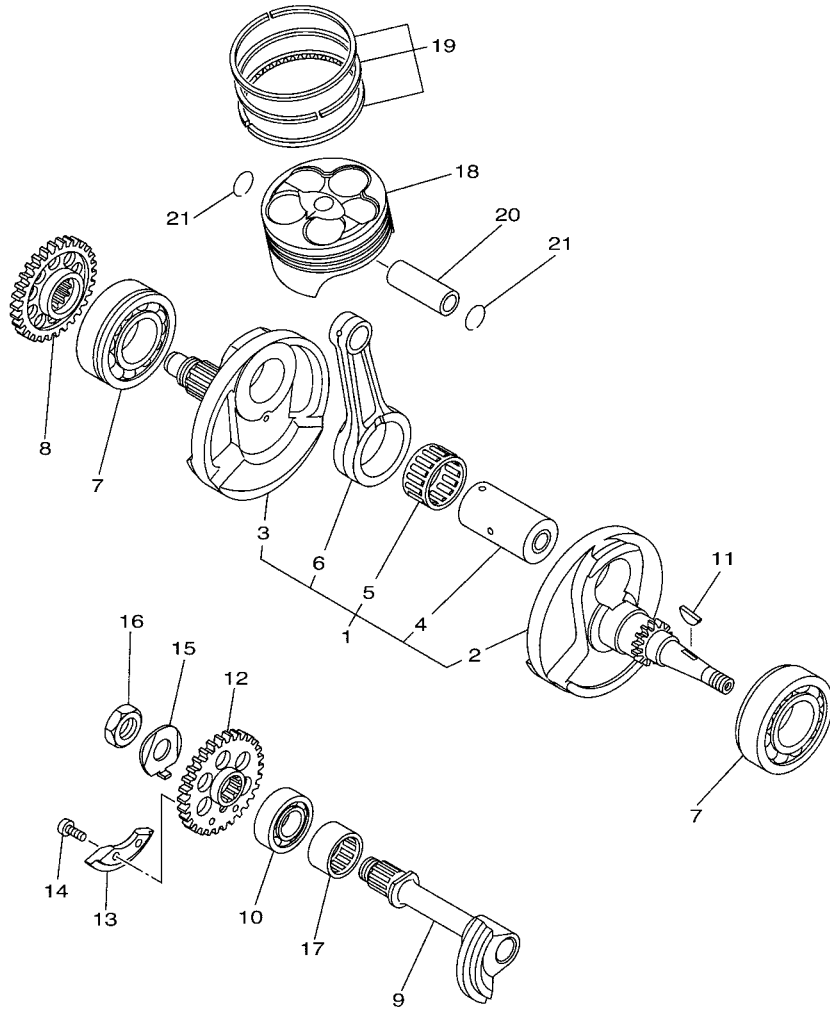

FIG. 1 CYLINDER

REF. NO.	PART NO.	DESCRIPTION	17D9	17DA	17DB	17DC	REMARKS
25	5NL-11351-00	GASKET, CYLINDER	1	1	1	1	
26	95702-06500	NUT, FLANGE	2	2	2	2	
27	93612-16254	PIN, DOWEL	2	2	2	2	
28	95022-06035	BOLT, FLANGE	1	1	1	1	
-----							
-----							
-----							
-----							
-----							
-----							
-----							
-----							





17D9110-L020

FIG. 2 CRANKSHAFT & PISTON

REF. NO.	PART NO.	DESCRIPTION	17D9	17DA	17DB	17DC	REMARKS
1	17D-11400-90	CRANKSHAFT ASSY	1	1	1	1	
2	17D-11412-90	.CRANK 1	1	1	1	1	
3	17D-11422-90	.CRANK 2	1	1	1	1	
4	5XC-11681-01	.PIN, CRANK 1	1	1	1	1	
5	93310-63290	.BEARING	1	1	1	1	
6	17D-11651-90	.ROD, CONNECTING	1	1	1	1	
7	93306-20648	BEARING	2	2	2	2	
8	5NL-11536-10	GEAR, DRIVE	1	1	1	1	
9	17D-11455-10	SHAFT 1	1	1	1	1	
10	93306-20335	BEARING	1	1	1	1	
11	90280-03006	KEY, WOODRUFF	1	1	1	1	
12	5NL-11531-00	GEAR, BALANCE WEIGHT	1	1	1	1	
13	17D-11454-90	WEIGHT 1	1	1	1	1	
14	90149-06084	SCREW	2	2	2	2	
15	90215-14204	WASHER, LOCK	1	1	1	1	
16	90170-14171	NUT	1	1	1	1	
17	93311-32261	BEARING	1	1	1	1	
18	17D-11631-90	PISTON (STD)	1	1	1	1	
19	17D-11603-00	PISTON RING SET (STD)	1	1	1	1	
20	17D-11633-00	PIN, PISTON	1	1	1	1	
21	93450-17129	CIRCLIP	2	2	2	2	

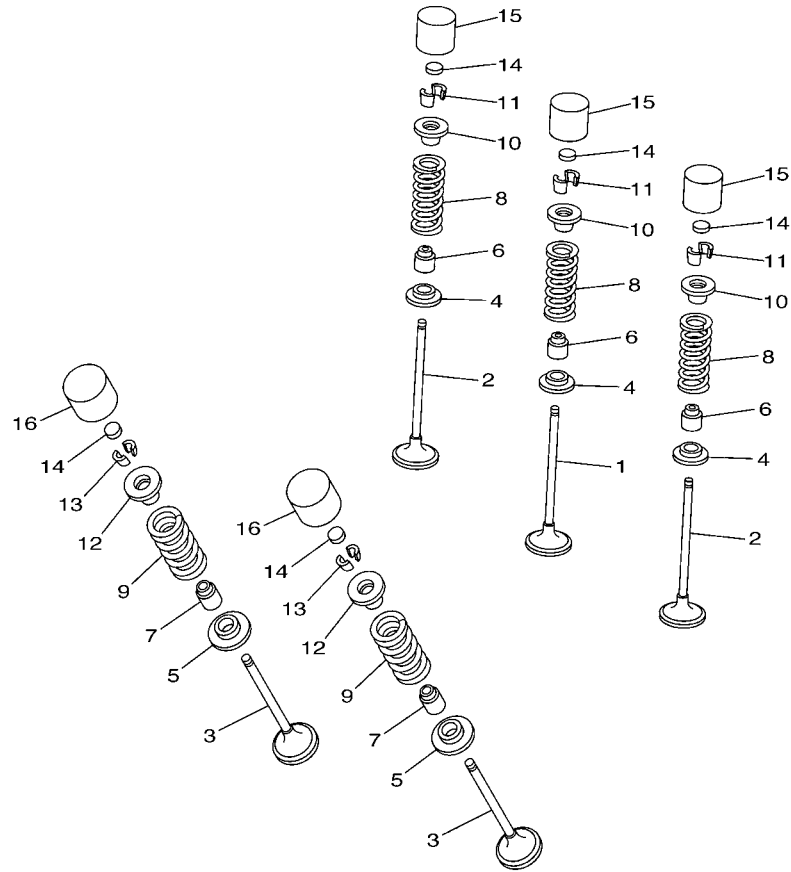

5NL1100-1030

FIG. 3 VALVE

REF. NO.	PART NO.	DESCRIPTION	17D9	17DA	17DB	17DC	REMARKS
1	5NL-12111-30	VALVE, INTAKE	1	1	1	1	
2	5NL-12112-30	VALVE, INTAKE 2	2	2	2	2	
3	5NL-12121-10	VALVE, EXHAUST	2	2	2	2	
4	5NL-12116-00	SEAT, VALVE SPRING	3	3	3	3	
5	3GM-12126-00	SEAT, VALVE SPRING 2	2	2	2	2	
6	4TV-12119-00	SEAL, VALVE STEM	3	3	3	3	
7	4SV-12119-00	SEAL, VALVE STEM	2	2	2	2	
8	5NL-12113-10	SPRING, VALVE INNER	3	3	3	3	
9	5NL-12114-10	SPRING, VALVE OUTER	2	2	2	2	
10	5VY-12117-00	RETAINER, VALVE SPRING	3	3	3	3	
11	1HX-12118-00	COTTER, VALVE	6	6	6	6	
12	5VY-12127-00	RETAINER, VALVE SPRING	2	2	2	2	
13	1WG-12118-00	COTTER, VALVE	4	4	4	4	
14	1HX-12168-00	PAD, ADJUSTING 2 (1.20)	5	5	5	5	UR
	1HX-12168-20	PAD, ADJUSTING 2 (1.25)	5	5	5	5	UR
	1HX-12168-40	PAD, ADJUSTING 2 (1.30)	5	5	5	5	UR
	1HX-12168-60	PAD, ADJUSTING 2 (1.35)	5	5	5	5	UR
	1HX-12168-80	PAD, ADJUSTING 2 (1.40)	5	5	5	5	UR
	1HX-12168-A0	PAD, ADJUSTING 2 (1.45)	5	5	5	5	UR
	1HX-12168-F0	PAD, ADJUSTING 2 (1.50)	5	5	5	5	UR
	1HX-12168-H1	PAD, ADJUSTING 2 (1.55)	5	5	5	5	UR
	1HX-12168-K1	PAD, ADJUSTING 2 (1.60)	5	5	5	5	UR
	1HX-12168-M1	PAD, ADJUSTING 2 (1.65)	5	5	5	5	UR
	1HX-12168-R1	PAD, ADJUSTING 2 (1.70)	5	5	5	5	UR
	1HX-12168-U1	PAD, ADJUSTING 2 (1.75)	5	5	5	5	UR
	1HX-12168-W1	PAD, ADJUSTING 2 (1.80)	5	5	5	5	UR
	1HX-12168-Y1	PAD, ADJUSTING 2 (1.85)	5	5	5	5	UR

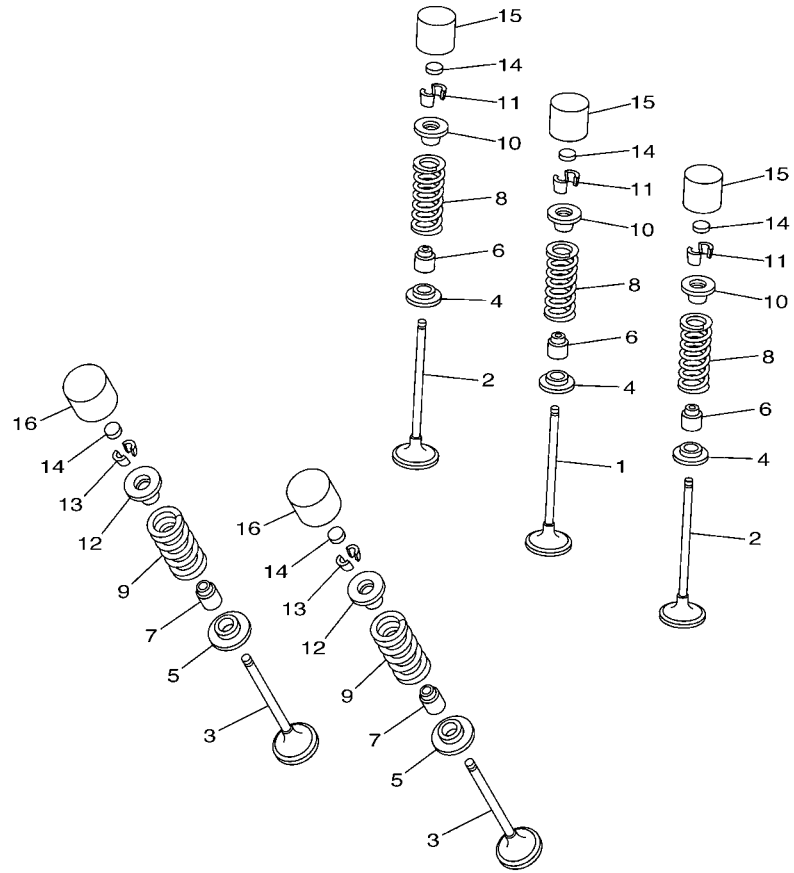
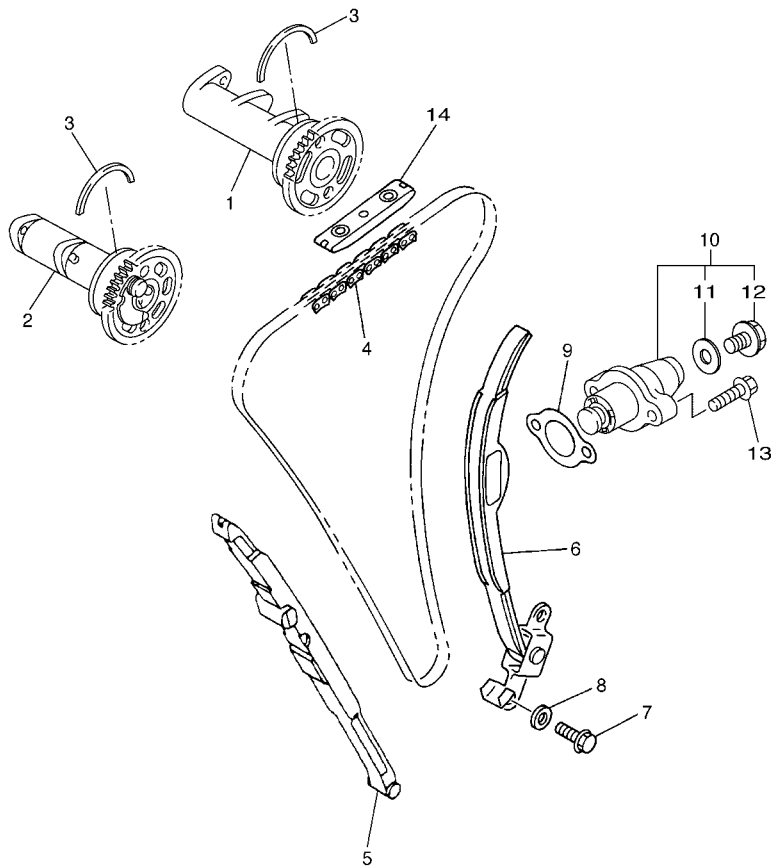

**FIG. 3 VALVE**

REF. NO.	PART NO.	DESCRIPTION	17D9	17DA	17DB	17DC	REMARKS
14	1HX-12169-11	PAD, ADJUSTING 2 (1.90)	5	5	5	5	UR
	1HX-12169-31	PAD, ADJUSTING 2 (1.95)	5	5	5	5	UR
	1HX-12169-50	PAD, ADJUSTING 2 (2.00)	5	5	5	5	UR
	1HX-12169-70	PAD, ADJUSTING 2 (2.05)	5	5	5	5	UR
	1HX-12169-90	PAD, ADJUSTING 2 (2.10)	5	5	5	5	UR
	1HX-12169-E0	PAD, ADJUSTING 2 (2.15)	5	5	5	5	UR
	1HX-12169-G0	PAD, ADJUSTING 2 (2.20)	5	5	5	5	UR
	1HX-12169-J0	PAD, ADJUSTING 2 (2.25)	5	5	5	5	UR
	1HX-12169-L0	PAD, ADJUSTING 2 (2.30)	5	5	5	5	UR
	1HX-12169-N0	PAD, ADJUSTING 2 (2.35)	5	5	5	5	UR
	1HX-12169-T0	PAD, ADJUSTING 2 (2.40)	5	5	5	5	UR
15	3LN-12153-10	LIFTER, VALVE	3	3	3	3	YELLOW
16	3FV-12153-10	LIFTER, VALVE	2	2	2	2	YELLOW



5NL1100-1030

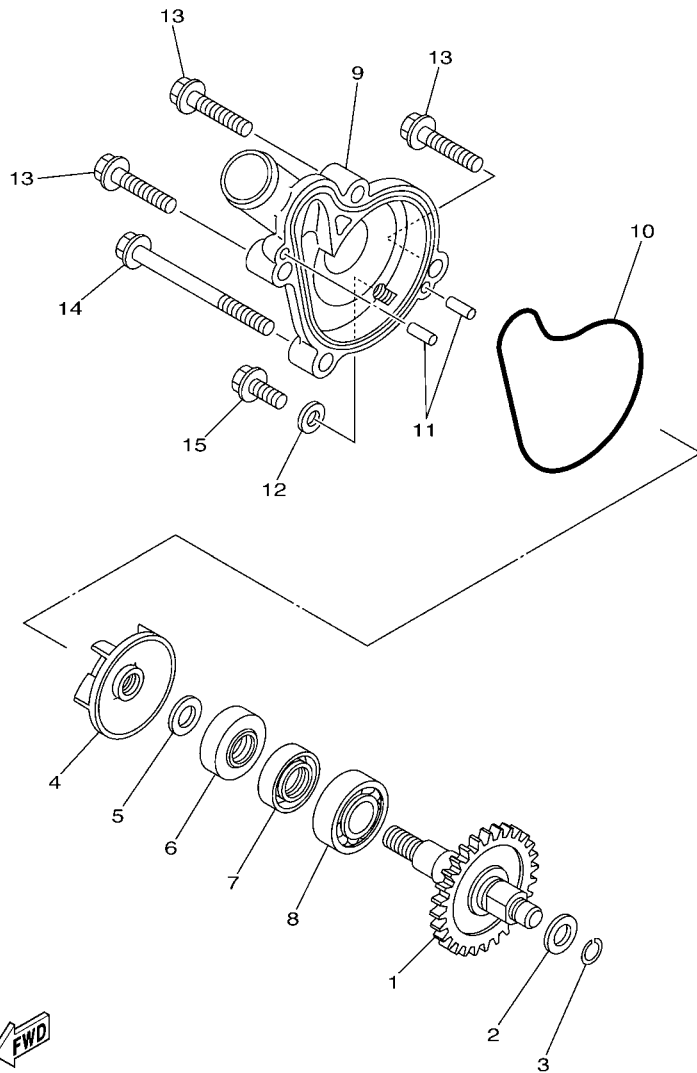

**FIG. 4 CAMSHAFT & CHAIN**

REF. NO.	PART NO.	DESCRIPTION	17D9	17DA	17DB	17DC	REMARKS
1	17D-12170-10	CAMSHAFT ASSY 1	1	1	1	1	
2	17D-12180-10	CAMSHAFT ASSY 2	1	1	1	1	
3	93440-41178	CIRCLIP	2	2	2	2	
4	94591-53114	CHAIN	1	1	1	1	
5	5NL-12251-30	DAMPER, CHAIN 1	1	1	1	1	
6	5NL-12252-00	DAMPER, CHAIN 2	1	1	1	1	
7	97022-06016	BOLT	2	2	2	2	
8	92902-06600	WASHER, PLATE	2	2	2	2	
9	4FM-12213-00	GASKET, TENSIONER CASE	1	1	1	1	
10	5TA-12210-20	TENSIONER ASSY, CAM CHAIN	1	1	1	1	
11	5EL-12214-00	.GASKET	1	1	1	1	
12	5EL-12228-00	.BOLT	1	1	1	1	
13	95022-06025	BOLT, FLANGE	2	2	2	2	
14	5BE-12241-00	GUIDE, STOPPER 2	1	1	1	1	



5XC9100-E041



5NL1100-1050

FIG. 5 WATER PUMP

REF. NO.	PART NO.	DESCRIPTION	17D9	17DA	17DB	17DC	REMARKS
1	5XC-12459-00	GEAR, IMPELLER SHAFT	1	1	1	1	
2	90201-08512	WASHER, PLATE	1	1	1	1	
3	93440-07182	CIRCLIP	1	1	1	1	
4	5DH-12451-00	IMPELLER, WATER PUMP	1	1	1	1	
5	90201-08512	WASHER, PLATE	1	1	1	1	
6	93109-11073	OIL SEAL	1	1	1	1	
7	93102-12106	OIL SEAL (SD 12-22-5 HS)	1	1	1	1	
8	93306-00105	BEARING	1	1	1	1	
9	5NL-12422-10	COVER, HOUSING	1	1	1	1	
10	5NL-12439-00	O-RING	1	1	1	1	
11	93604-10011	PIN, DOWEL	2	2	2	2	
12	90430-06014	GASKET	1	1	1	1	
13	95022-06025	BOLT, FLANGE	3	3	3	3	
14	95022-06065	BOLT, FLANGE	1	1	1	1	
15	95022-06012	BOLT, FLANGE	1	1	1	1	

**FIG. 6 RADIATOR & HOSE**

REF. NO.	PART NO.	DESCRIPTION	17D9	17DA	17DB	17DC	REMARKS
1	17D-1240A-50	RADIATOR ASSY	1	1	1	1	
2	17D-12461-50	RADIATOR COMP	1	1	1	1	
3	5SL-12462-00	CAP, RADIATOR	1	1	1	1	
4	91A20-05065	TUBE, FLEXIBLE VINYL	1	1	1	1	
5	90467-090A2	CLIP	1	1	1	1	
6	5XC-12481-G0	PIPE 1	1	1	1	1	
7	93210-16275	O-RING	1	1	1	1	
8	91312-06020	BOLT	1	1	1	1	
9	17D-12576-50	HOSE 1	1	1	1	1	
10	17D-12577-50	HOSE 2	1	1	1	1	
11	17D-12578-50	HOSE 3	1	1	1	1	
12	17D-12579-50	HOSE 4	1	1	1	1	
13	17D-12588-50	HOSE 5	1	1	1	1	
14	17D-12581-50	JOINT, HOSE 1	1	1	1	1	
15	90450-25001	HOSE CLAMP ASSY	3	3	3	3	
16	90450-28001	HOSE CLAMP ASSY	4	4	4	4	
17	90450-32003	HOSE CLAMP ASSY	1	1	1	1	
18	90450-22001	HOSE CLAMP ASSY	2	2	2	2	
19	4KB-24181-00	DAMPER, LOCATING 1	1	1	1	1	
20	90480-15012	GROMMET	6	6	6	6	
21	90387-06065	COLLAR	6	6	6	6	
22	90105-06111	BOLT, FLANGE	6	6	6	6	
23	90201-06571	WASHER, PLATE	5	5	5	5	

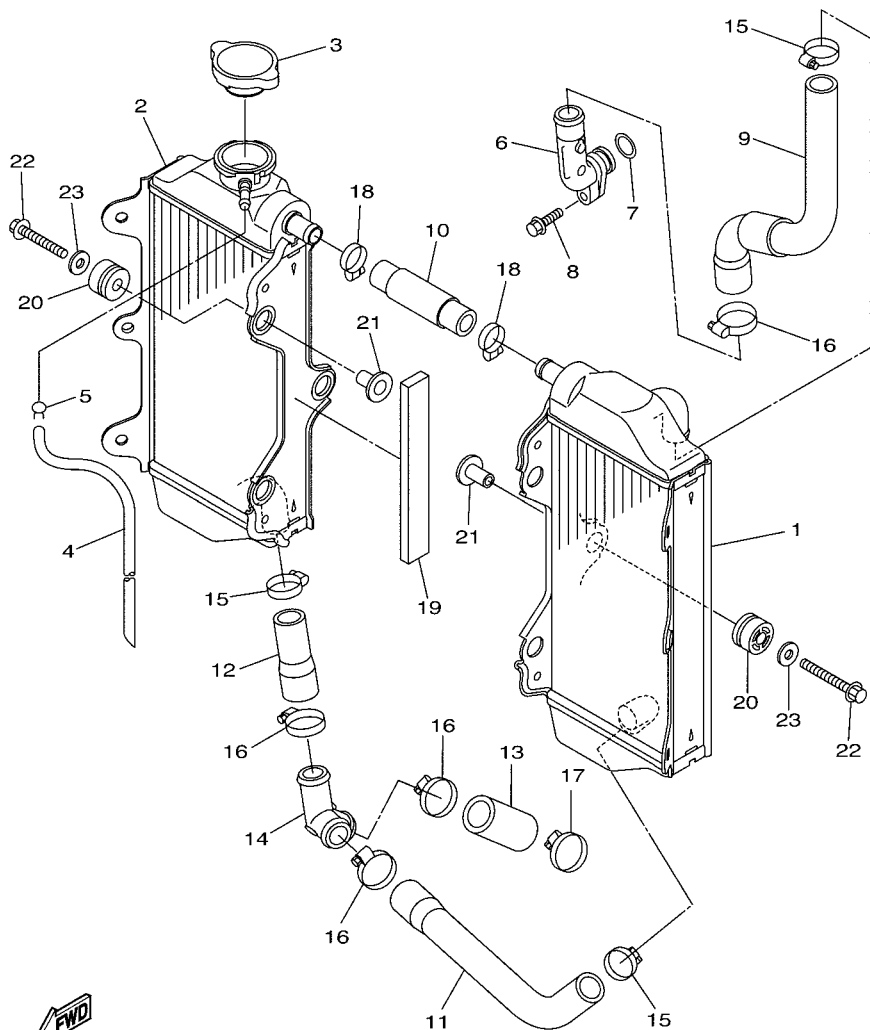

17D5110-J060

FIG. 7 OIL PUMP

REF. NO.	PART NO.	DESCRIPTION	17D9	17DA	17DB	17DC	REMARKS
1	5SG-13300-01	OIL PUMP ASSY	1	1	1	1	
2	93603-16219	PIN, DOWEL	1	1	1	1	
3	5NL-13320-00	ROTOR ASSY 2	1	1	1	1	
4	93440-10153	CIRCLIP	1	1	1	1	
5	99530-08012	PIN, DOWEL	1	1	1	1	
6	91312-06025	BOLT	2	2	2	2	
7	91317-06030	BOLT	1	1	1	1	
8	93210-10197	O-RING	1	1	1	1	
9	99530-10114	PIN, DOWEL	1	1	1	1	
10	5BE-13342-00	SHAFT, IDLE GEAR	1	1	1	1	
11	5NL-13341-00	GEAR, OIL PUMP IDLE	1	1	1	1	
12	99001-08600	CIRCLIP	1	1	1	1	
13	90201-12166	WASHER, PLATE	1	1	1	1	
14	99009-12400	CIRCLIP	1	1	1	1	
15	5XC-13412-00	HOUSING, STRAINER	1	1	1	1	
16	5NL-13411-00	STRAINER, OIL	1	1	1	1	
17	95022-06025	BOLT, FLANGE	2	2	2	2	
18	17D-13464-00	HOSE, OIL 1	1	1	1	1	
19	93210-10197	O-RING	1	1	1	1	
20	99530-10114	PIN, DOWEL	1	1	1	1	
21	95022-06025	BOLT, FLANGE	1	1	1	1	
22	90450-22001	HOSE CLAMP ASSY	1	1	1	1	
23	17D-13465-00	HOSE, OIL 2	1	1	1	1	
24	95022-06025	BOLT, FLANGE	1	1	1	1	
25	93210-10197	O-RING	1	1	1	1	
26	99530-10114	PIN, DOWEL	1	1	1	1	
27	95022-06016	BOLT, FLANGE	1	1	1	1	

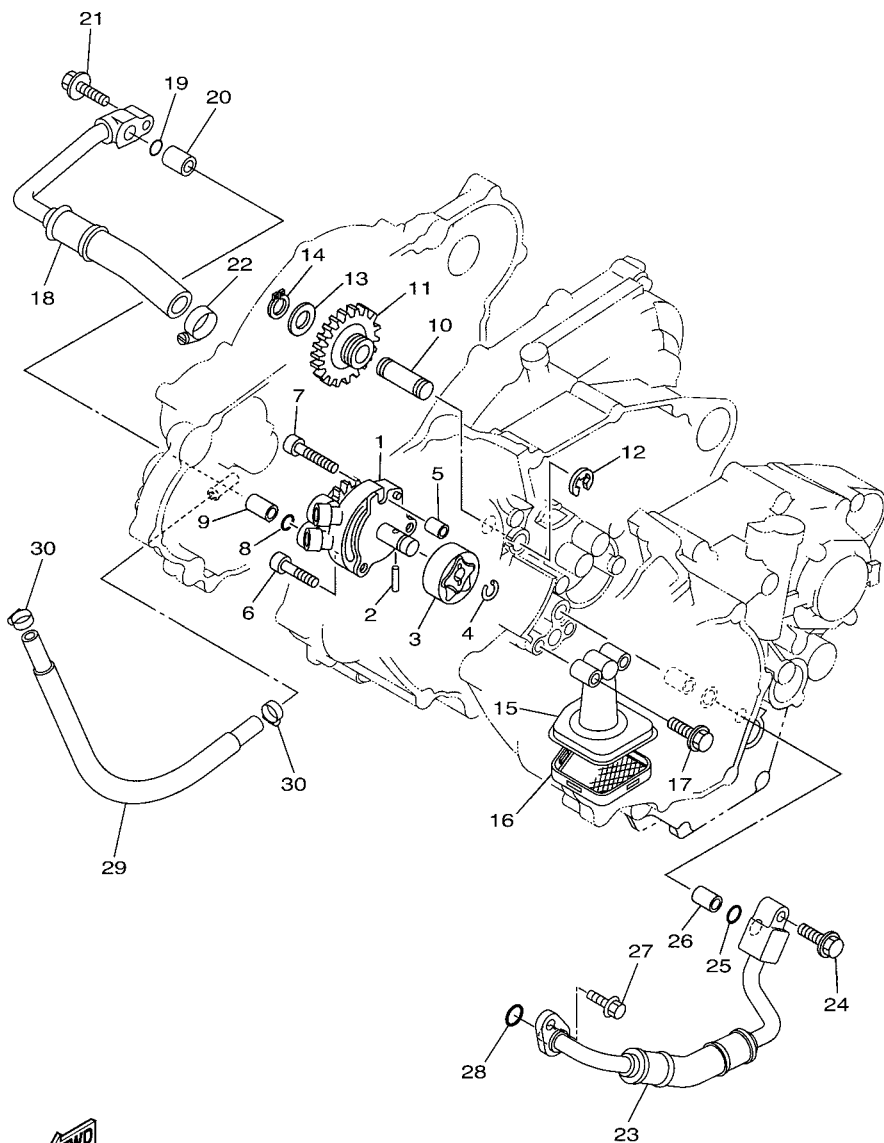

17D5110-J070







5XCG100-F080

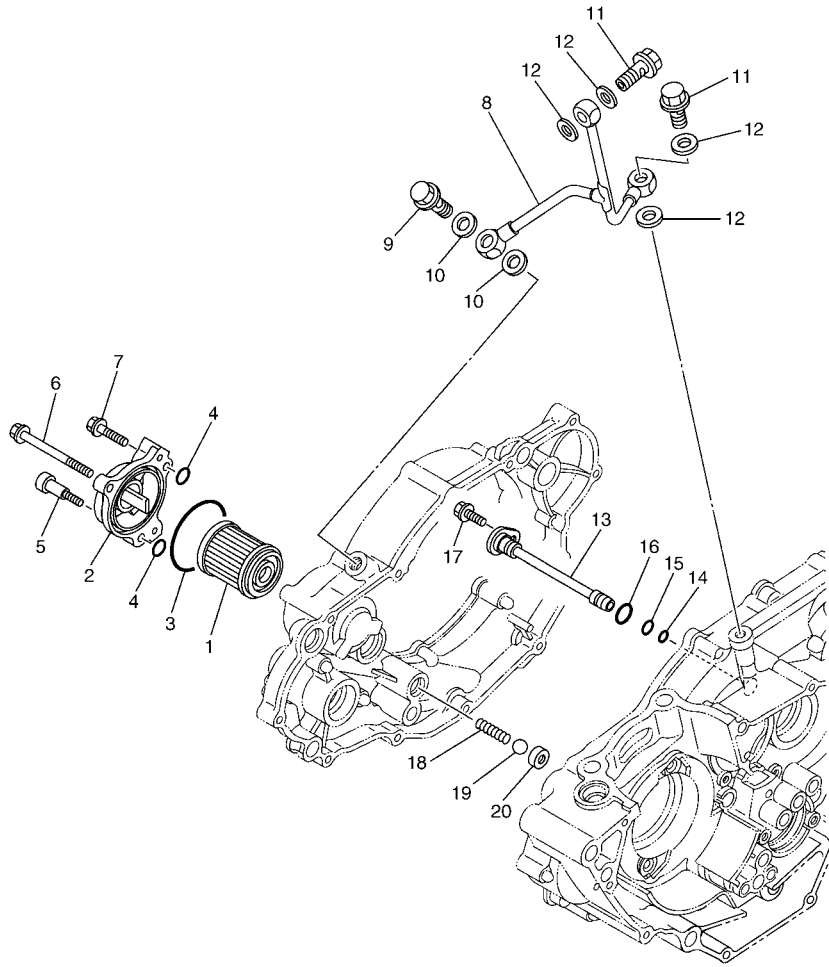

FIG. 8 OIL CLEANER

REF. NO.	PART NO.	DESCRIPTION	17D9	17DA	17DB	17DC	REMARKS
1	5D3-13440-01	ELEMENT ASSY, OIL CLEANER	1	1	1	1	
2	5BE-13447-30	COVER, OIL ELEMENT	1	1	1	1	
3	93210-47675	O-RING	1	1	1	1	
4	93210-07135	O-RING	3	3	3	3	
5	90110-06228	BOLT, HEXAGON SOCKET HEAD	1	1	1	1	
6	91312-06065	BOLT	1	1	1	1	
7	91312-06025	BOLT	1	1	1	1	
8	5NL-13161-21	PIPE, DELIVERY 1	1	1	1	1	
9	90401-10015	BOLT, UNION	1	1	1	1	
10	90430-10188	GASKET	2	2	2	2	
11	90401-08006	BOLT, UNION	2	2	2	2	
12	90430-08119	GASKET	4	4	4	4	
13	5NL-13171-10	PIPE, DELIVERY 2	1	1	1	1	
14	93210-07003	O-RING	1	1	1	1	
15	93210-09525	O-RING	1	1	1	1	
16	93210-12010	O-RING	1	1	1	1	
17	95022-06012	BOLT, FLANGE	1	1	1	1	
18	90501-043E0	SPRING, COMPRESSION	1	1	1	1	
19	93503-08007	BALL	1	1	1	1	
20	583-13113-00	SEAT, CHECK BALL	1	1	1	1	

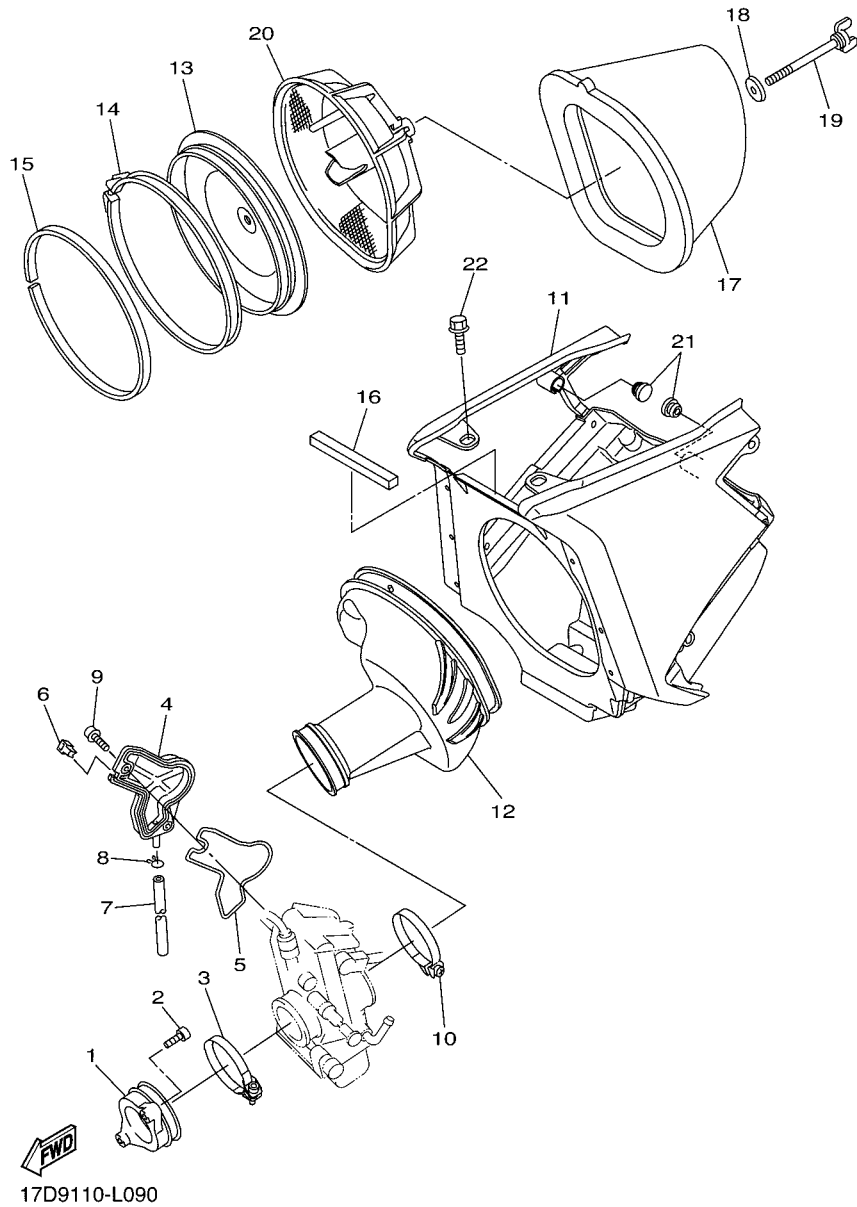
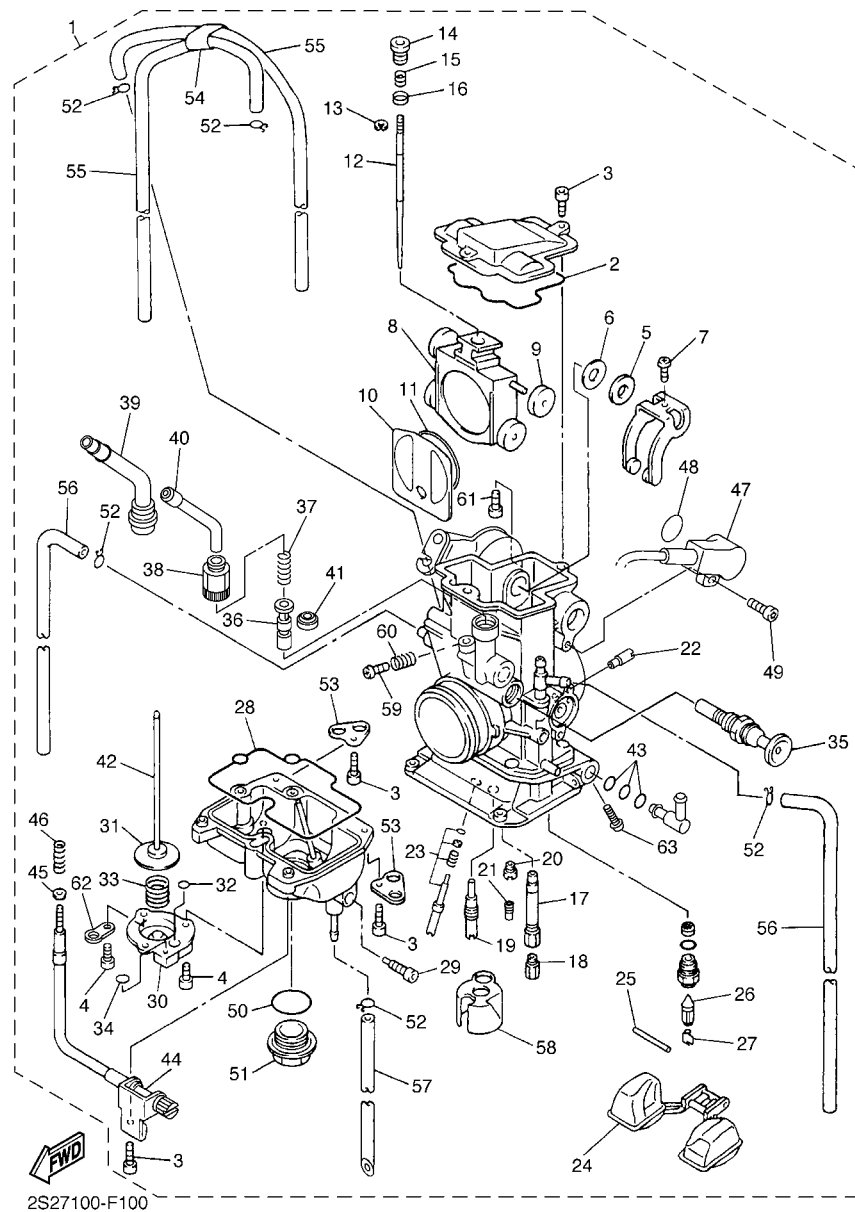

FIG. 9 INTAKE

REF. NO.	PART NO.	DESCRIPTION	17D9	17DA	17DB	17DC	REMARKS
1	17D-13597-90	JOINT, CARBURETOR 3	1	1	1	1	
2	91312-06025	BOLT	2	2	2	2	
3	90450-58006	HOSE CLAMP ASSY	1	1	1	1	
4	5TA-14293-00	COVER 1	1	1	1	1	
5	5TA-14227-00	GASKET	1	1	1	1	
6	5TA-14239-00	SEAL	1	1	1	1	
7	5TA-14987-00	HOSE	1	1	1	1	
8	3TJ-14137-40	CLIP	1	1	1	1	
9	90110-05038	BOLT, HEXAGON SOCKET HEAD	2	2	2	2	
10	90450-61002	HOSE CLAMP ASSY	1	1	1	1	
11	17D-14401-00	AIR CLEANER CASE ASSY	1	1	1	1	
12	17D-14453-50	JOINT, AIR CLEANER 1	1	1	1	1	
13	5NY-14459-00	HOLDER, GUIDE	1	1	1	1	
14	5NY-14455-20	BAND	1	1	1	1	
15	5NY-14442-00	SPACER	1	1	1	1	
16	17D-14452-00	SEAL	1	1	1	1	
17	4XM-14451-00	ELEMENT, AIR CLEANER	1	1	1	1	
18	90209-06096	WASHER	1	1	1	1	
19	90122-06005	BOLT, WING	1	1	1	1	
20	17D-14458-00	GUIDE	1	1	1	1	
21	90480-10068	GROMMET	2	2	2	2	
22	90105-06170	BOLT, FLANGE	2	2	2	2	



2S27100-F100

FIG. 10 CARBURETOR

REF. NO.	PART NO.	DESCRIPTION	17D9	17DA	17DB	17DC	REMARKS
1	17D-14101-90	CARBURETOR ASSY 1	1			1	
	17D-14101-A0	CARBURETOR ASSY 1		1	1		
2	5JG-14959-00	.GASKET	1	1	1	1	
3	91316-04012	.BOLT	6	6	6	6	
4	688-14592-00	.SCREW	3	3	3	3	
5	90202-08045	.WASHER, PLATE	1	1	1	1	
6	5JG-14951-00	.WASHER	1	1	1	1	
7	5JG-14522-00	.SCREW, ADJUST	1	1	1	1	
8	2S2-14388-00	.VALVE, VACUUM CONTROL	1	1	1	1	
9	3TJ-14267-40	.ROLLER	1	1	1	1	
10	5JG-14546-01	.VALVE, NEEDLE	1	1	1	1	
11	4FN-14997-00	.SEAL	1	1	1	1	
12	5TA-14916-PR	.NEEDLE (#NFP R)	1			1	STD
	5TA-14916-P1	.NEEDLE (#NFP Q)		1	1		STD
	5TA-14916-PN	.NEEDLE (#NFP N)	1	1	1	1	AP
	5TA-14916-PP	.NEEDLE (#NFP P)	1	1	1	1	AP
	5TA-14916-P1	.NEEDLE (#NFP Q)	1			1	AP
	5TA-14916-PS	.NEEDLE (#NFP S)	1	1	1	1	AP
	5TA-14916-PT	.NEEDLE (#NFP T)	1	1	1	1	AP
	5TA-14916-PU	.NEEDLE (#NFP U)	1			1	AP
	5TA-14916-LN	.NEEDLE (#NFL N)	1	1	1	1	AP
	5TA-14916-LP	.NEEDLE (#NFL P)	1	1	1	1	AP
	5TA-14916-L1	.NEEDLE (#NFL Q)	1	1	1	1	AP
	5TA-14916-LR	.NEEDLE (#NFL R)	1	1	1	1	AP
	5TA-14916-LS	.NEEDLE (#NFL S)	1	1	1	1	AP
	5TA-14916-LT	.NEEDLE (#NFL T)	1	1	1	1	AP
	5TA-14916-LU	.NEEDLE (#NFL U)	1			1	AP

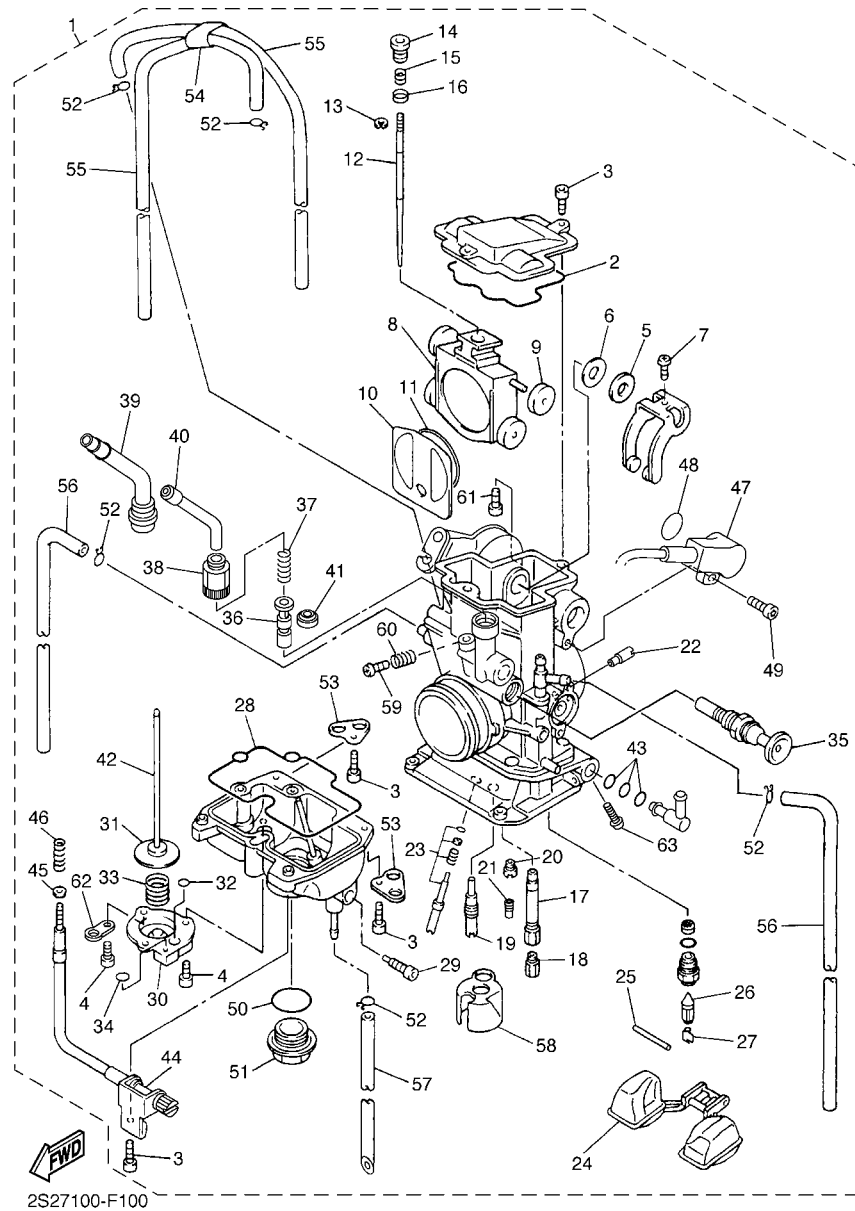

2S27100-F100

FIG. 10 CARBURETOR

REF. NO.	PART NO.	DESCRIPTION	17D9	17DA	17DB	17DC	REMARKS
12	5TA-14916-PM	.NEEDLE (#NFPM)		1	1		AP
	5TA-14916-PR	.NEEDLE (#NFPR)		1	1		AP
	5TA-14916-LM	.NEEDLE (#NFLM)		1	1		AP
13	3TJ-14159-40	.CLIP	1	1	1	1	
14	5JG-14521-00	.SCREW, ADJUST	1	1	1	1	
15	5JG-14275-00	.SPRING	1	1	1	1	
16	5JG-14264-00	.COLLAR	1	1	1	1	
17	17D-14947-00	.JET, NEEDLE	1	1	1	1	
18	4MX-14943-43	.JET, MAIN (#180)	1	1	1	1	STD
	4MX-14943-42	.JET, MAIN (#175)	1	1	1	1	AP
	4MX-14943-93	.JET, MAIN (#178)	1	1	1	1	AP
	4MX-14943-94	.JET, MAIN (#182)	1	1	1	1	AP
	4MX-14943-44	.JET, MAIN (#185)	1	1	1	1	AP
	4MX-14943-95	.JET, MAIN (#188)	1	1	1	1	AP
	4MX-14943-45	.JET, MAIN (#190)	1	1	1	1	AP
	4MX-14943-96	.JET, MAIN (#192)	1	1	1	1	AP
	4MX-14943-46	.JET, MAIN (#195)	1	1	1	1	AP
19	17D-14948-02	.JET, SLOW (#38)	1	1	1	1	STD
	4MX-14948-01	.JET, SLOW (#35)	1	1	1	1	AP
	4MX-14948-02	.JET, SLOW (#38)	1	1	1	1	AP
	4MX-14948-03	.JET, SLOW (#40)	1	1	1	1	AP
	4MX-14948-04	.JET, SLOW (#42)	1	1	1	1	AP
20	3TJ-1494F-16	.JET (#72)	1	1	1	1	STD
	3TJ-1494F-13	.JET (#65)	1	1	1	1	AP
	3TJ-1494F-14	.JET (#68)	1	1	1	1	AP
	3TJ-1494F-15	.JET (#70)	1	1	1	1	AP
	3TJ-1494F-17	.JET (#75)	1	1	1	1	AP

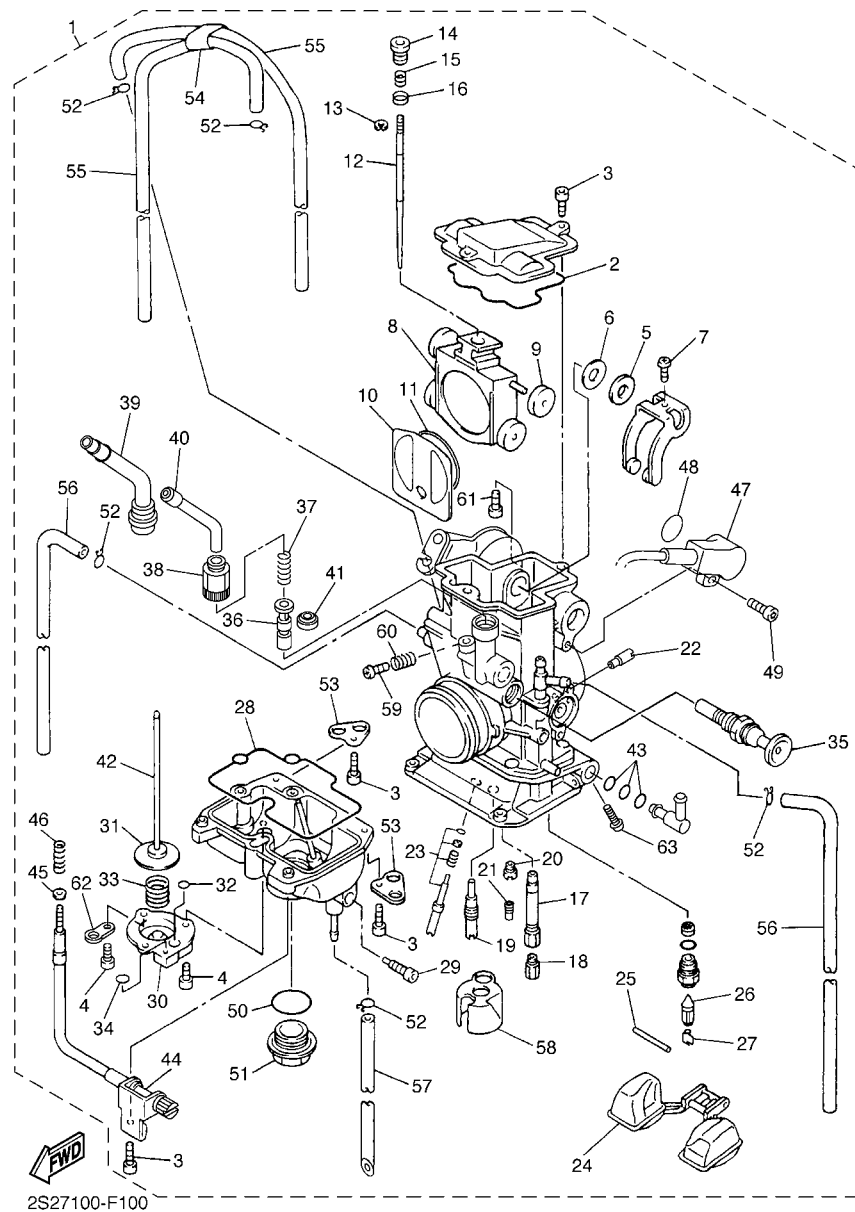

2S27100-F100

FIG. 10 CARBURETOR

REF. NO.	PART NO.	DESCRIPTION	17D9	17DA	17DB	17DC	REMARKS
20	3TJ-1494F-18	.JET (#78)	1	1	1	1	AP
	3TJ-1494F-19	.JET (#80)	1	1	1	1	AP
21	4JT-1494F-25	.JET (#95)	1	1	1	1	STD
	4JT-1494F-13	.JET (#65)	1	1	1	1	AP
	4JT-1494F-17	.JET (#75)	1	1	1	1	AP
	4JT-1494F-21	.JET (#85)	1	1	1	1	AP
	4JT-1494F-28	.JET (#105)	1	1	1	1	AP
	4JT-1494F-30	.JET (#115)	1	1	1	1	AP
	4JT-1494F-32	.JET (#125)	1	1	1	1	AP
22	5TA-14943-27	.JET, MAIN (#100)	1	1	1	1	
23	5NL-14105-00	.PILOT SCREW SET	1	1	1	1	
24	17D-14985-00	.FLOAT	1	1	1	1	
25	676-14548-00	.PIN, FLOAT ARM	1	1	1	1	
26	4MX-14392-00	.VALVE, NEEDLE	1	1	1	1	
27	633-14159-00	.CLIP	1	1	1	1	
28	5JG-14984-00	.GASKET, FLOAT CHAMBER	1	1	1	1	
29	3TJ-14191-40	.PLUG, DRAIN	1	1	1	1	
30	3TJ-14293-40	.COVER 1	1	1	1	1	
31	5JG-14940-76	.DIAPHRAGM, ACC PUMP (DPH#30)	1	1	1	1	STD
	5JG-14940-16	.DIAPHRAGM, ACC PUMP (DPH#45)	1	1	1	1	AP
	5JG-14940-17	.DIAPHRAGM, ACC PUMP (DPH#35)	1	1	1	1	AP
	5JG-14940-18	.DIAPHRAGM, ACC PUMP (DPH#25)	1	1	1	1	AP
32	3TJ-14536-40	.GASKET	1	1	1	1	
33	3TJ-14933-40	.SPRING, DIAPHRAGM	1	1	1	1	
34	6H4-14561-00	.O-RING	1	1	1	1	
35	5XC-14171-00	.PLUNGER, STARTER	1	1	1	1	
36	5TA-14371-00	.PLUNGER, STARTER	1	1	1	1	

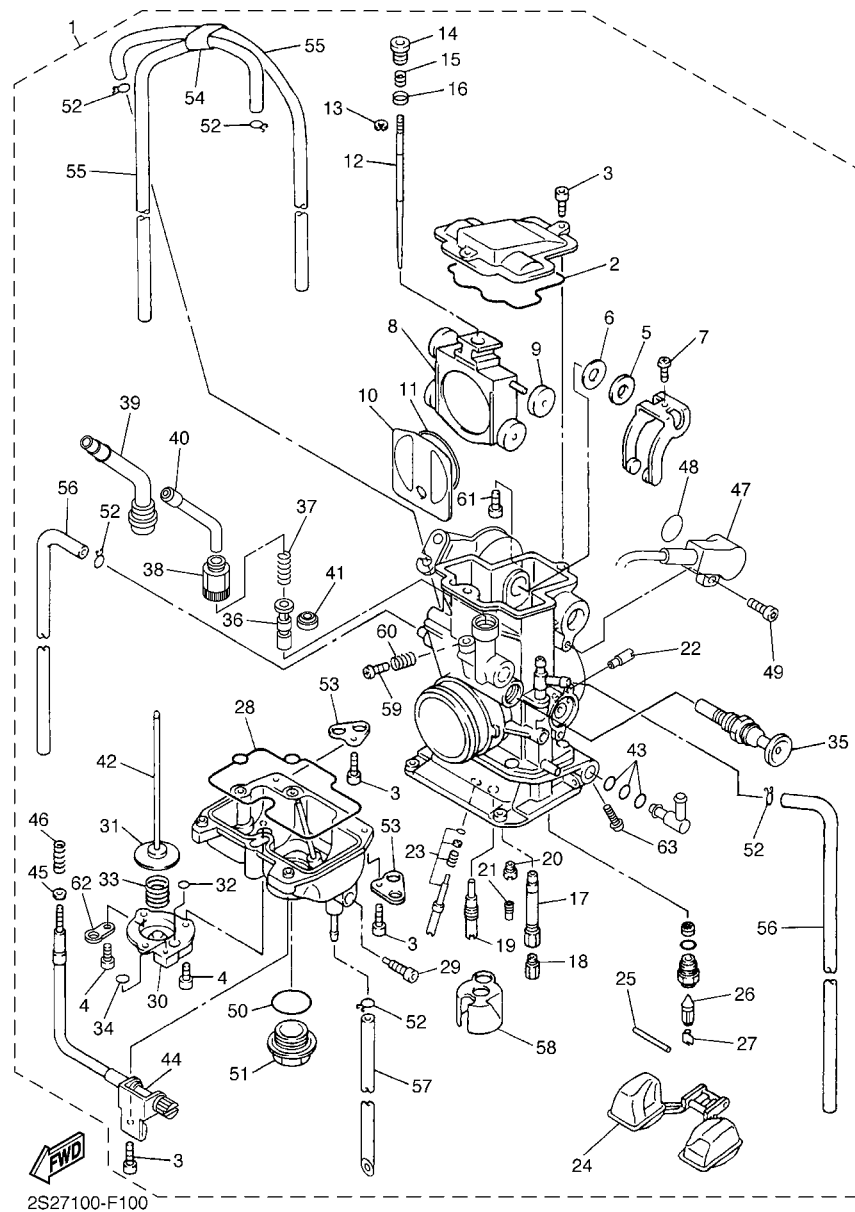

2S27100-F100

FIG. 10 CARBURETOR

REF. NO.	PART NO.	DESCRIPTION	17D9	17DA	17DB	17DC	REMARKS
37	5TA-14335-00	.SPRING, PLUNGER	1	1	1	1	
38	5TA-14991-00	.SCREW	1	1	1	1	
39	2S2-14374-00	.CAP, PLUNGER	1	1	1	1	
40	5TA-14155-00	.GUIDE, CABLE	1	1	1	1	
41	5TA-14997-00	.SEAL	1	1	1	1	
42	5JG-14379-00	.ROD, STARTER	1	1	1	1	
43	3TJ-14564-40	.O-RING	3	3	3	3	
44	5XC-14922-00	.SCREW, THROTTLE	1	1	1	1	
45	90201-08410	.WASHER, PLATE	1	1	1	1	
46	5TA-14934-00	.SPRING, THROTTLE STOP	1	1	1	1	
47	17D-85885-00	.THROTTLE SENSOR ASSY	1	1	1	1	
48	5NX-14562-00	.O-RING	1	1	1	1	
49	5NX-14216-00	.SCREW	1	1	1	1	
50	4MX-14561-00	.O-RING	1	1	1	1	
51	4MX-14115-00	.PLUG, SCREW	1	1	1	1	
52	3TJ-14137-40	.CLIP	5	5	5	5	
53	5BE-14146-00	.PLATE	2	2	2	2	
54	5TA-14261-00	.HOLDER	1	1	1	1	
55	5UL-14196-00	.PIPE, OVER FLOW 1	2	2	2	2	
56	5TA-14197-00	.PIPE	2	2	2	2	
57	5TJ-14987-00	.HOSE	1	1	1	1	
58	5JG-14346-00	.PLATE	1	1	1	1	
59	5JG-14565-00	.SCREW	1	1	1	1	
60	5JG-14531-00	.SPRING, ADJUST SCREW	1	1	1	1	
61	5NL-14591-00	.SCREW	1	1	1	1	
62	5PA-14146-00	.PLATE	1	1	1	1	
63	5XD-14325-00	.SCREW, PAN HEAD	1	1	1	1	

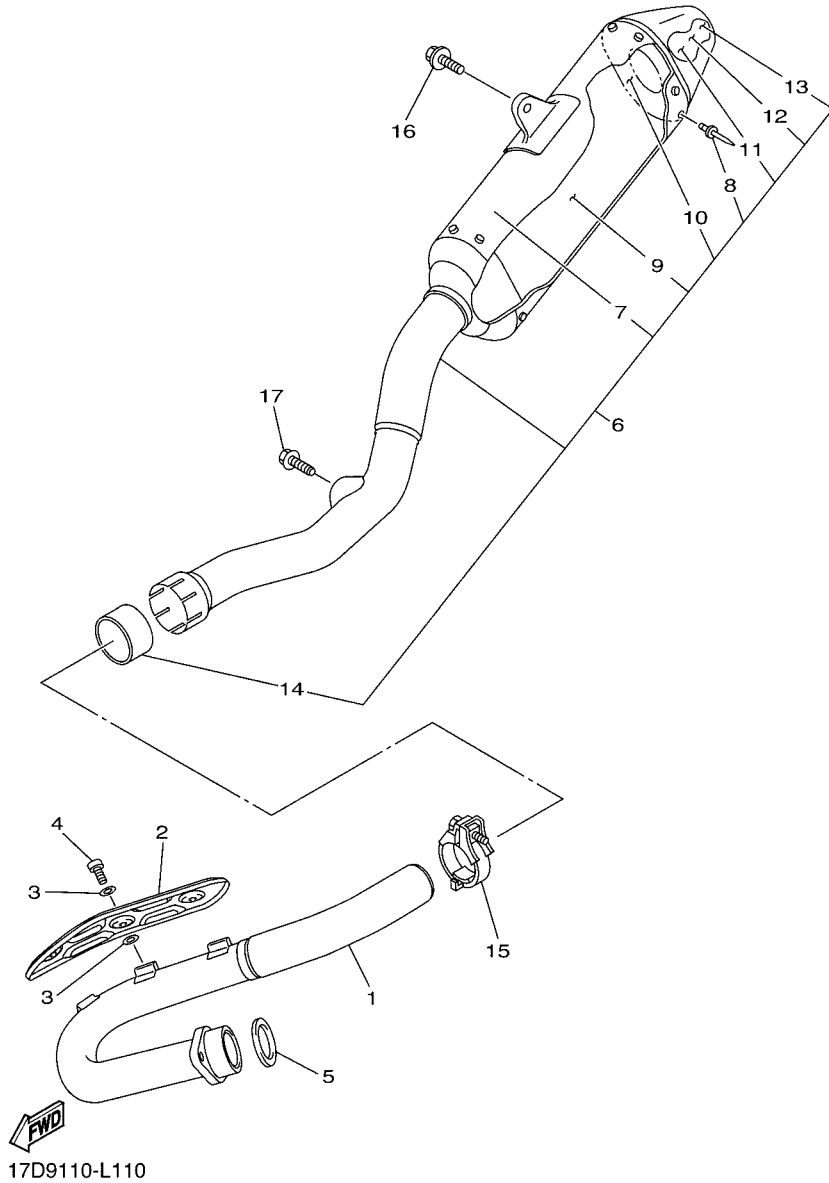
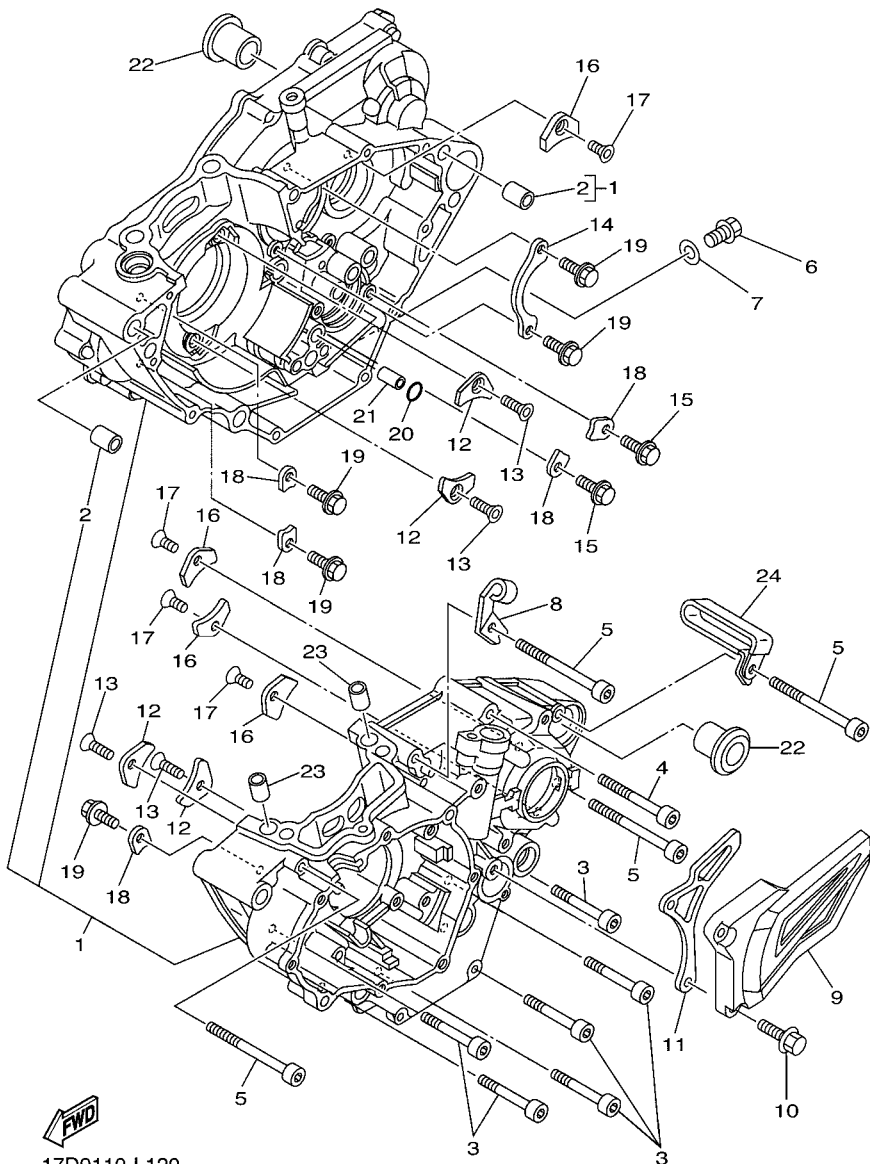

FIG. 11 EXHAUST

REF. NO.	PART NO.	DESCRIPTION	17D9	17DA	17DB	17DC	REMARKS
1	17D-14611-90	PIPE, EXHAUST 1	1	1	1	1	
2	5XC-14628-R0	PROTECTOR, EXHAUST PIPE	1	1	1	1	
3	90201-05017	WASHER, PLATE	6	6	6	6	
4	98980-06008	SCREW, BIND	3	3	3	3	
5	5NL-14613-00	GASKET, EXHAUST PIPE	1	1	1	1	
6	17D-14750-90	SILENCER ASSY	1				
	17D-14750-A0	SILENCER ASSY		1	1	1	
7	17D-1466G-50	.BODY, SILENCER	1	1	1	1	
8	90267-48084	.RIVET, BLIND	16	16	16	16	
9	17D-1477A-00	.FIBER,1	1	1	1	1	
10	2S2-1469F-00	.FIBER	2	2	2	2	
11	17D-1469E-00	.FIBER	3				
12	17D-1469F-00	.FIBER	2				
13	17D-1469G-00	.FIBER 4	1				
14	5XD-14714-00	.GASKET, MUFFLER	1	1	1	1	
15	5BE-14788-00	BAND, SILENCER	1	1	1	1	
16	90119-08133	BOLT, WITH WASHER	1	1	1	1	
17	90105-08224	BOLT, FLANGE	1	1	1	1	

FIG. 12 CRANKCASE

REF. NO.	PART NO.	DESCRIPTION	17D9	17DA	17DB	17DC	REMARKS
1	5XC-15100-38-YX	CRANKCASE ASSY	1	1	1	1	
2	93612-16254	.PIN, DOWEL	2	2	2	2	
3	91312-06045	BOLT	6	6	6	6	
4	91312-06055	BOLT	1	1	1	1	
5	91312-06070	BOLT	4	4	4	4	
6	95022-10016	BOLT, FLANGE	1	1	1	1	
7	90430-10188	GASKET	1	1	1	1	
8	5NL-15441-01	HOLDER, CLUTCH CABLE	1	1	1	1	
9	17D-15421-90	COVER, CRANKCASE 2	1	1	1	1	
10	90105-06189	BOLT, FLANGE	2	2	2	2	
11	5NL-17466-00	GUIDE, CHAIN	1	1	1	1	
12	5BE-15383-01	PLATE, BEARING COVER	4	4	4	4	
13	90151-06071	SCREW, COUNTERSUNK	4	4	4	4	
14	5NL-15388-00	PLATE, BEARING COVER	1	1	1	1	
15	90105-06081	BOLT, FLANGE	2	2	2	2	
16	4JT-15381-01	PLATE, BEARING COVER	4	4	4	4	
17	90149-06074	SCREW	4	4	4	4	
18	5DH-18562-00	PLATE, STOPPER 2	5	5	5	5	
19	90105-06081	BOLT, FLANGE	5	5	5	5	
20	93210-10197	O-RING	1	1	1	1	
21	99530-10114	PIN, DOWEL	1	1	1	1	
22	90387-18007	COLLAR	2	2	2	2	
23	99530-10116	PIN, DOWEL	2	2	2	2	
24	90465-10013	CLAMP	1	1	1	1	



17D9110-L120



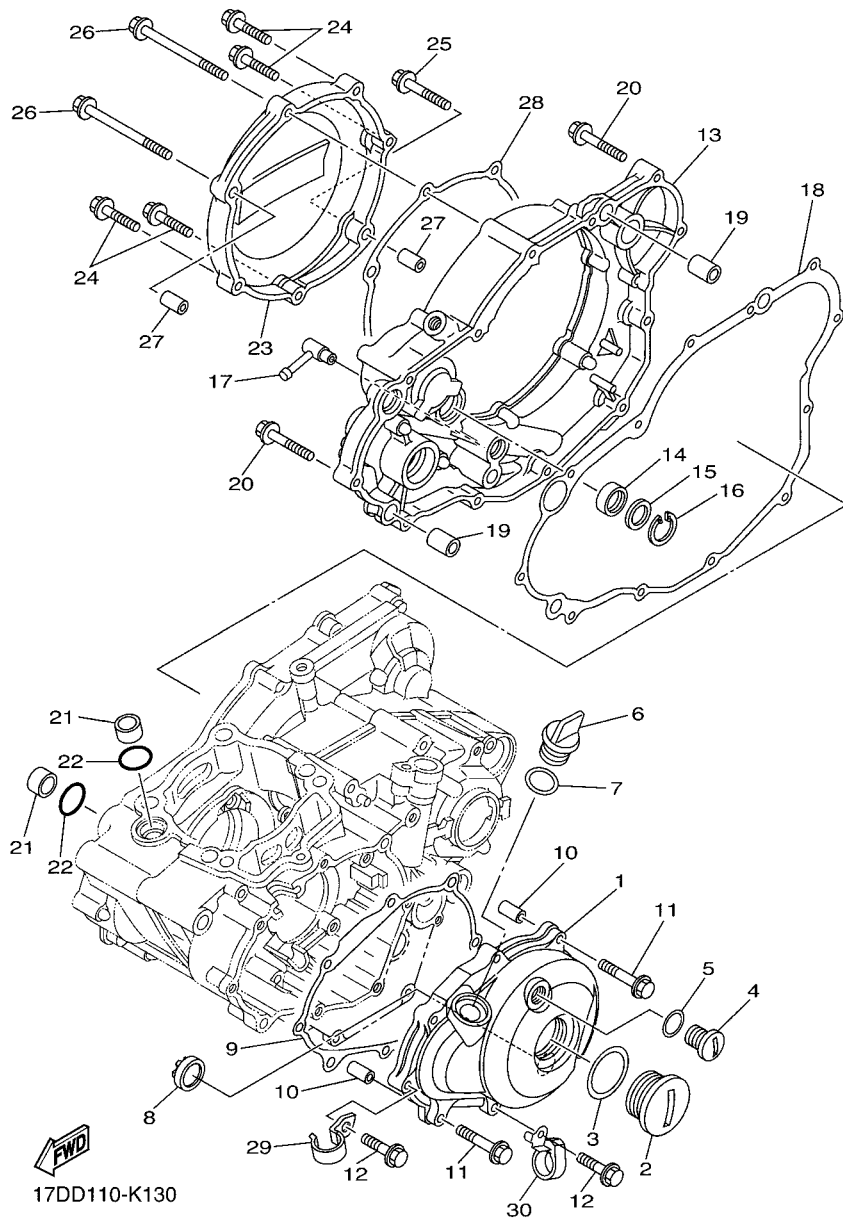

FIG. 13 CRANKCASE COVER 1

REF. NO.	PART NO.	DESCRIPTION	17D9	17DA	17DB	17DC	REMARKS
1	17D-15411-50	COVER, CRANKCASE 1	1	1	1	1	
2	90340-32006	PLUG, STRAIGHT SCREW	1	1	1	1	
3	93210-32172	O-RING	1	1	1	1	
4	90340-14015	PLUG, STRAIGHT SCREW	1	1	1	1	
5	93210-14369	O-RING	1	1	1	1	
6	3Y1-15363-10	PLUG, OIL	1	1	1	1	
7	93210-19123	O-RING	1	1	1	1	
8	3Y1-15361-00	GAUGE, LEVEL	1	1	1	1	
9	5NL-15451-00	GASKET, CRANKCASE COVER 1	1	1	1	1	
10	99530-08016	PIN, DOWEL	2	2	2	2	
11	95022-06035	BOLT, FLANGE	2	2	2	2	
12	95022-06025	BOLT, FLANGE	6	6	6	6	
13	5XC-15431-01	COVER, CRANKCASE 3	1	1	1	1	
14	93101-14164	OIL SEAL	1	1	1	1	
15	90201-15701	WASHER, PLATE (T=1.0)	1	1	1	1	
16	99009-22500	CIRCLIP	1	1	1	1	
17	5XC-15373-00	PIPE, BREATHER	1	1	1	1	
18	5NL-15462-00	GASKET, CRANKCASE COVER 3	1	1	1	1	
19	91812-16001	PIN, DOWEL	2	2	2	2	
20	95022-06035	BOLT, FLANGE	8	8	8	8	
21	5NL-12564-00	PIPE, WATER	2	2	2	2	
22	93210-16716	O-RING	2	2	2	2	
23	5NL-15415-40	COVER, GENERATOR	1	1	1	1	
24	95022-06025	BOLT, FLANGE	4	4	4	4	
25	95022-06035	BOLT, FLANGE	1	1	1	1	
26	90105-06098	BOLT, FLANGE	2	2	2	2	
27	99530-08016	PIN, DOWEL	2	2	2	2	



FIG. 14 STARTER

REF. NO.	PART NO.	DESCRIPTION	17D9	17DA	17DB	17DC	REMARKS
1	5NL-15601-30	KICK SHAFT ASSY	1	1	1	1	
2	5NL-15641-30	.GEAR, KICK	1	1	1	1	
3	90201-20685	.WASHER, PLATE (T=0.5)	1	1	1	1	
4	93410-20038	.CIRCLIP	1	1	1	1	
5	2S2-15671-00	.WHEEL, RATCHET	1	1	1	1	
6	90501-160A2	.SPRING, COMPRESSION	1	1	1	1	
7	90201-167P7	.WASHER, PLATE	1	1	1	1	
8	99009-16400	.CIRCLIP	1	1	1	1	
9	90508-30743	.SPRING, TORSION	1	1	1	1	
10	5NL-15664-00	.GUIDE, SPRING	1	1	1	1	
11	90201-162H4	WASHER, PLATE	1	1	1	1	
12	5SG-15668-00	STOPPER	1	1	1	1	
13	214-15686-00	WASHER, LOCK	1	1	1	1	
14	90101-06044	BOLT	2	2	2	2	
15	93102-18278	OIL SEAL	1	1	1	1	
16	5NL-15651-00	GEAR, KICK IDLE	1	1	1	1	
17	90201-177G4	WASHER, PLATE	1	1	1	1	
18	99009-17400	CIRCLIP	1	1	1	1	
19	17D-15620-50	KICK CRANK ASSY	1	1	1	1	
20	17D-15621-50	.BOSS, KICK CRANK	1	1	1	1	
21	90501-147A5	.SPRING, COMPRESSION	1	1	1	1	
22	93507-32009	.BALL	1	1	1	1	
23	90151-06045	.SCREW, COUNTERSUNK	1	1	1	1	
24	93210-17570	.O-RING	1	1	1	1	
25	90201-08048	WASHER, PLATE	1	1	1	1	
26	90110-08051	BOLT, HEXAGON SOCKET HEAD	1	1	1	1	

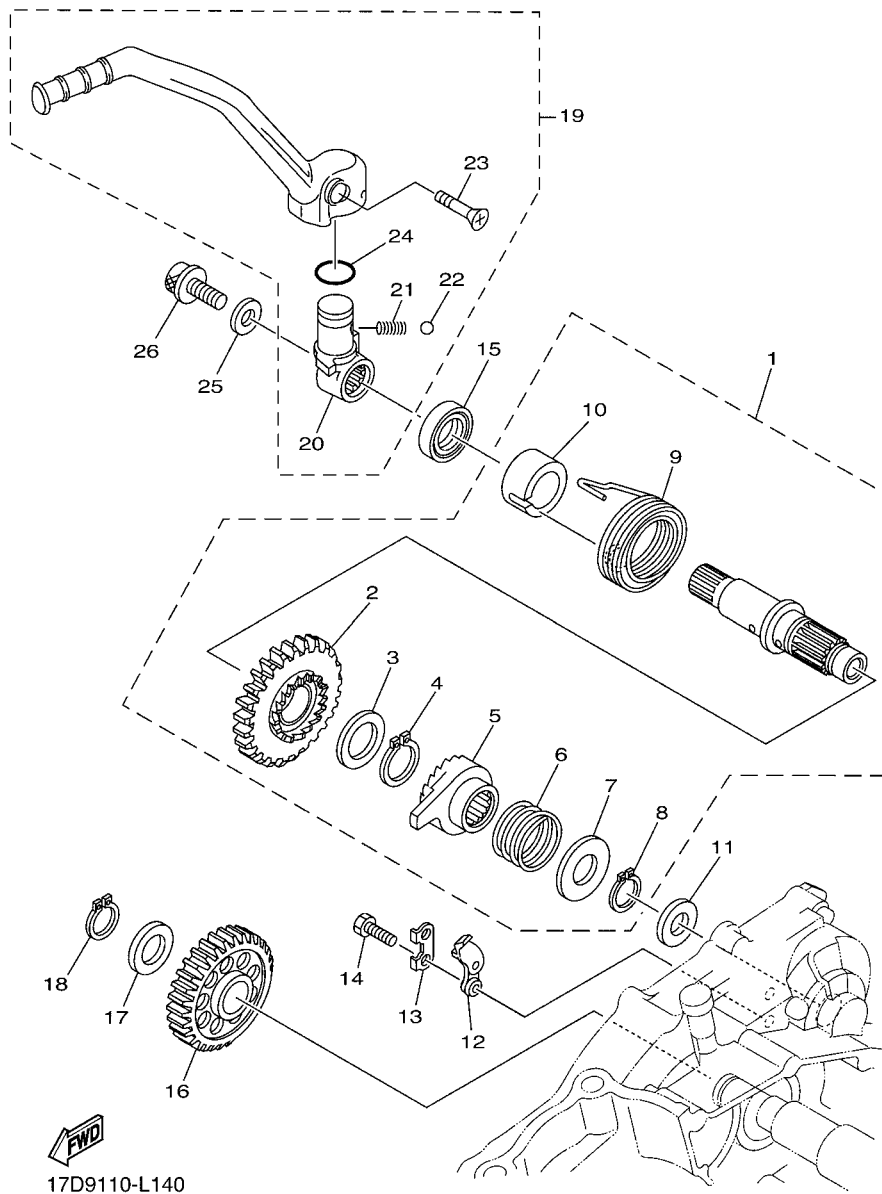

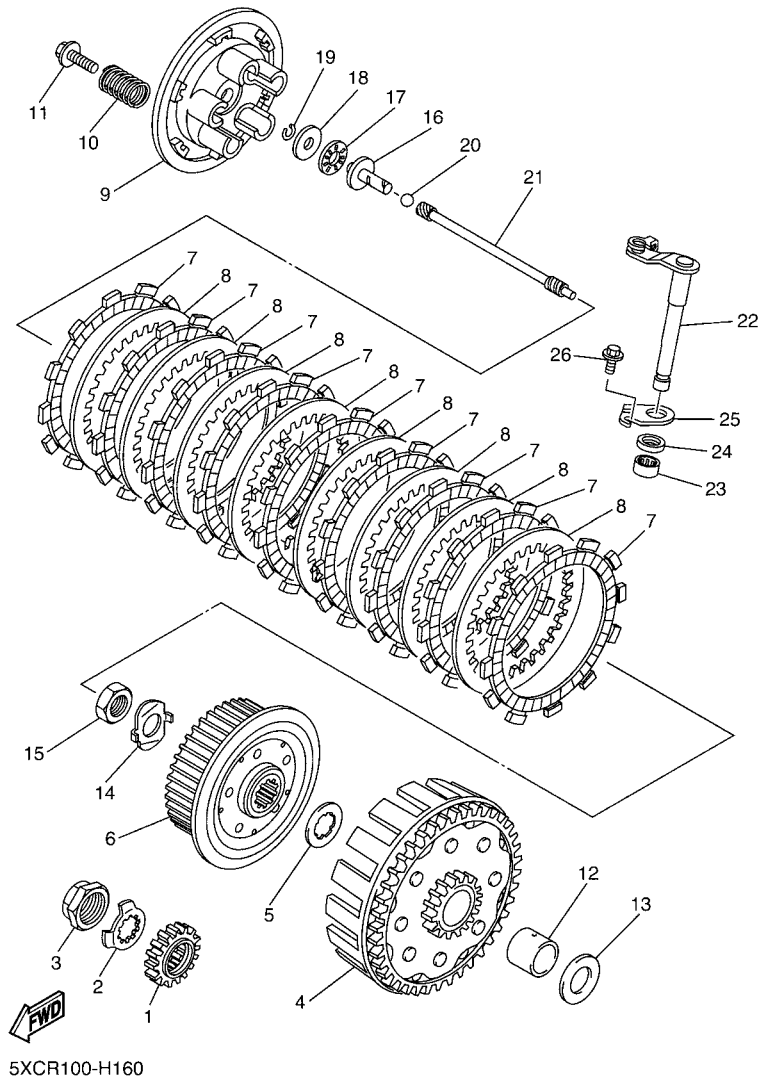
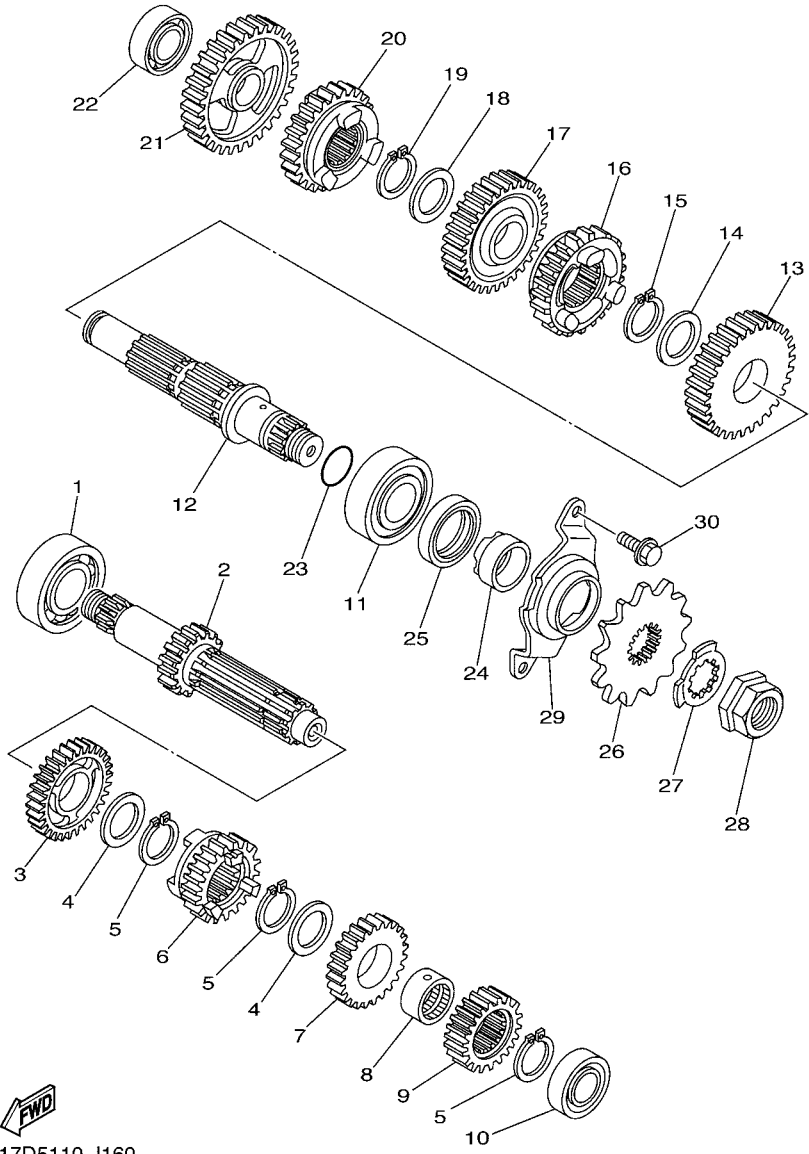

FIG. 15 CLUTCH

REF. NO.	PART NO.	DESCRIPTION	17D9	17DA	17DB	17DC	REMARKS
1	5NL-16111-01	GEAR, PRIMARY DRIVE	1	1	1	1	
2	90215-20003	WASHER, LOCK	1	1	1	1	
3	90179-18001	NUT	1	1	1	1	
4	5XC-16150-10	PRIMARY DRIVEN GEAR COMP.	1	1	1	1	
5	5XC-16154-00	PLATE, THRUST 1	1	1	1	1	
6	5NL-16371-31	BOSS, CLUTCH	1	1	1	1	
7	5XC-16321-00	PLATE, FRICTION	9	9	9	9	
8	5NL-16325-00	PLATE, CLUTCH 2	8	8	8	8	
9	5HD-16351-00	PLATE, PRESSURE 1	1	1	1	1	
10	90501-230A2	SPRING, COMPRESSION	5	5	5	5	
11	90159-06092	SCREW, WITH WASHER	5	5	5	5	
12	5XC-16181-00	SPACER 1	1	1	1	1	
13	90201-22013	WASHER, PLATE	1	1	1	1	
14	90215-16289	WASHER, LOCK	1	1	1	1	
15	90170-16326	NUT	1	1	1	1	
16	5XC-16356-00	ROD, PUSH 1	1	1	1	1	
17	93340-21008	BEARING	1	1	1	1	
18	90201-080H1	WASHER, PLATE	1	1	1	1	
19	93440-07182	CIRCLIP	1	1	1	1	
20	93511-32027	BALL	1	1	1	1	
21	5NL-16357-10	ROD, PUSH 2	1	1	1	1	
22	5XC-16381-10	PUSH LEVER COMP.	1	1	1	1	
23	93317-11295	BEARING	1	1	1	1	
24	93102-12224	OIL SEAL	1	1	1	1	
25	4JT-16384-00	PLATE, SEAT	1	1	1	1	
26	95022-06010	BOLT, FLANGE	1	1	1	1	



17D5110-J160

FIG. 16 TRANSMISSION

REF. NO.	PART NO.	DESCRIPTION	17D9	17DA	17DB	17DC	REMARKS
1	93306-20447	BEARING	1	1	1	1	
2	5XC-17411-00	AXLE, MAIN (14T)	1	1	1	1	
3	17D-17151-10	GEAR, 5TH PINION (24T)	1	1	1	1	
4	90209-20008	WASHER	2	2	2	2	
5	93410-22039	CIRCLIP	3	3	3	3	
6	17D-17131-10	GEAR, 3RD PINION (18T)	1	1	1	1	
7	17D-17141-10	GEAR, 4TH PINION (18T)	1	1	1	1	
8	90387-20006	COLLAR	1	1	1	1	
9	5NL-17121-00	GEAR, 2ND PINION (16T)	1	1	1	1	
10	93306-00320	BEARING	1	1	1	1	
11	93306-27209	BEARING	1	1	1	1	
12	5NL-17402-01	DRIVE AXLE ASSY	1	1	1	1	
13	5NL-17221-00	GEAR, 2ND WHEEL (28T)	1	1	1	1	
14	90209-23012	WASHER	1	1	1	1	
15	93410-26067	CIRCLIP	1	1	1	1	
16	17D-17241-10	GEAR, 4TH WHEEL (22T)	1	1	1	1	
17	17D-17231-10	GEAR, 3RD WHEEL (26T)	1	1	1	1	
18	90209-20008	WASHER	1	1	1	1	
19	93410-22039	CIRCLIP	1	1	1	1	
20	17D-17251-11	GEAR, 5TH WHEEL (25T)	1	1	1	1	
21	5NL-17211-10	GEAR, 1ST WHEEL (30T)	1	1	1	1	
22	93306-00317	BEARING	1	1	1	1	
23	93210-196A4	O-RING	1	1	1	1	
24	90387-22001	COLLAR	1	1	1	1	
25	93102-28010	OIL SEAL	1	1	1	1	
26	9383B-13218	SPROCKET, DRIVE (13T)	1	1	1	1	
27	90215-20003	WASHER, LOCK	1	1	1	1	





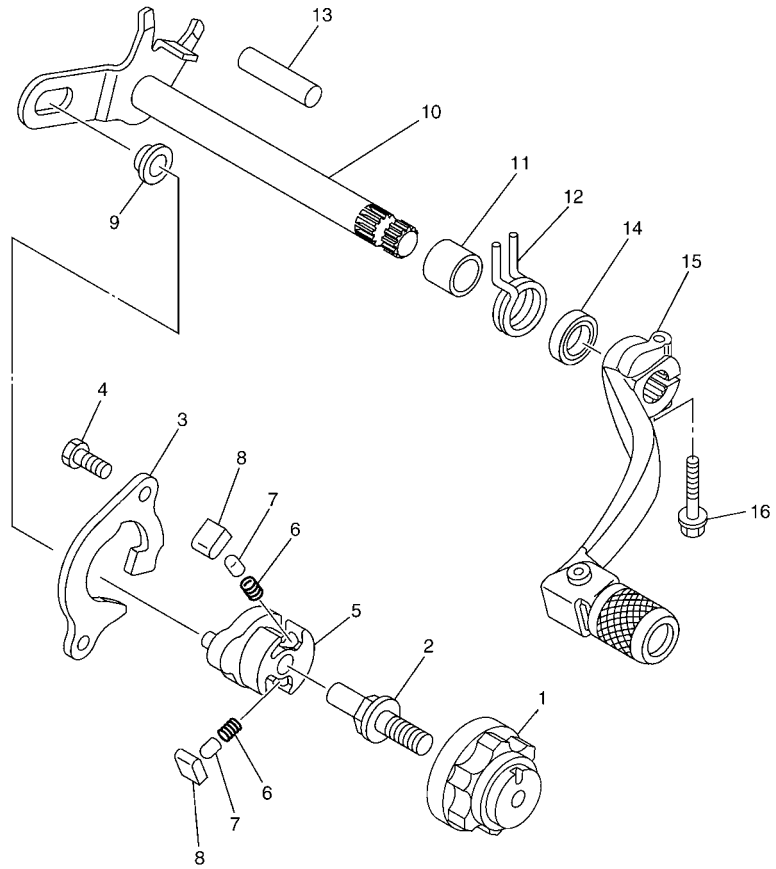

5XCG100-F180

FIG. 18 SHIFT SHAFT

REF. NO.	PART NO.	DESCRIPTION	17D9	17DA	17DB	17DC	REMARKS
1	2S2-18185-00	SEGMENT	1	1	1	1	
2	3XJ-18173-10	PIN, SHIFT	1	1	1	1	
3	5BE-18172-00	GUIDE, SHIFT	1	1	1	1	
4	90101-06041	BOLT	2	2	2	2	
5	5LP-18122-01	LEVER, SHIFT 2	1	1	1	1	
6	90501-052G5	SPRING, COMPRESSION	2	2	2	2	
7	3XJ-18184-00	PIN, PAWL	2	2	2	2	
8	3XJ-18182-00	PAWL, SHIFTER	2	2	2	2	
9	3XJ-18178-00	ROLLER, SHIFT LEVER	1	1	1	1	
10	5UL-18101-20	SHIFT SHAFT ASSY	1	1	1	1	
11	90387-124F4	COLLAR	1	1	1	1	
12	90508-291A8	SPRING, TORSION	1	1	1	1	
13	93608-33002	PIN, DOWEL	1	1	1	1	
14	93102-12224	OIL SEAL	1	1	1	1	
15	5XC-18110-10	SHIFT PEDAL ASSY	1	1	1	1	
16	90105-06127	BOLT, FLANGE	1	1	1	1	



FIG. 19 FRAME

REF. NO.	PART NO.	DESCRIPTION	17D9	17DA	17DB	17DC	REMARKS
1	17D-21101-90	FRONT FRAME COMP.	1	1	1	1	
2	17D-21447-00	.BRACKET, FOOTREST	1	1	1	1	
3	17D-21448-00	.BRACKET, FOOTREST	1	1	1	1	
4	90149-10031	.SCREW	4	4	4	4	
5	17D-21335-50	.CLAMP, WIRE HARNESS 1	1	1	1	1	
6	92012-05008	.BOLT, BUTTON HEAD	2	2	2	2	
7	17D-21190-10	REAR FRAME COMP.	1	1	1	1	
8	90105-08224	BOLT, FLANGE	4	4	4	4	
9	90387-08096	COLLAR	2	2	2	2	
10	17D-21131-00	BRACKET	1	1	1	1	
11	30X-22178-00	TENSIONER	1	1	1	1	
12	4V4-22184-00	BUSH	1	1	1	1	
13	90201-08045	WASHER, PLATE	2	2	2	2	
14	90387-08041	COLLAR	1	1	1	1	
15	95022-08040	BOLT, FLANGE	1	1	1	1	
16	3JD-22178-20	TENSIONER	1	1	1	1	
17	93300-60839	BEARING	1	1	1	1	
18	90387-086N4	COLLAR	1	1	1	1	
19	90105-08232	BOLT, FLANGE	1	1	1	1	
20	90185-08009	NUT, SELF-LOCKING	1	1	1	1	
21	90201-08043	WASHER, PLATE	1	1	1	1	
22	90105-10361	BOLT, FLANGE	1	1	1	1	
23	90179-10658	NUT	1	1	1	1	
24	90201-10045	WASHER, PLATE	1	1	1	1	
25	90105-08226	BOLT, FLANGE	4	4	4	4	
26	17D-21425-90	BRACKET, REAR UPPER 1	1	1	1	1	
27	17D-21426-90	BRACKET, REAR UPPER 2	1	1	1	1	

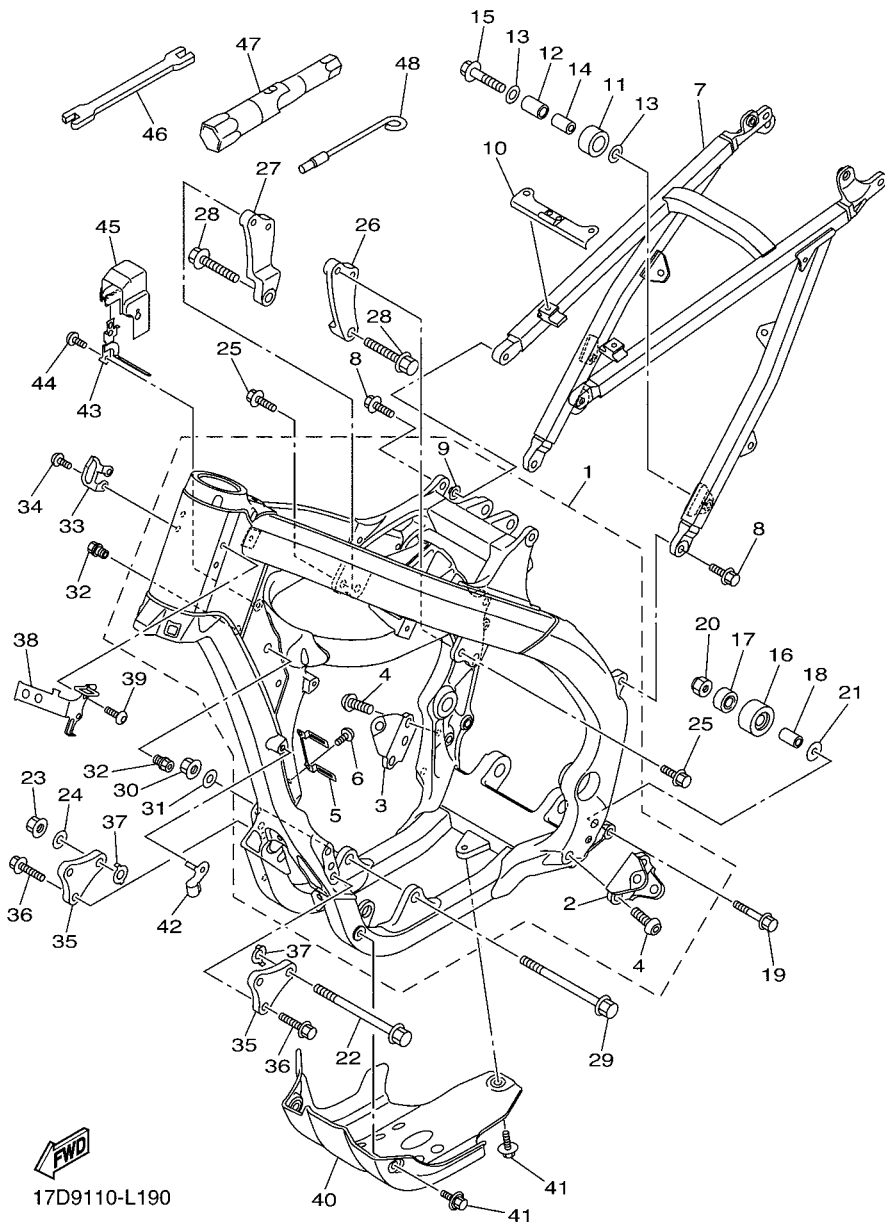
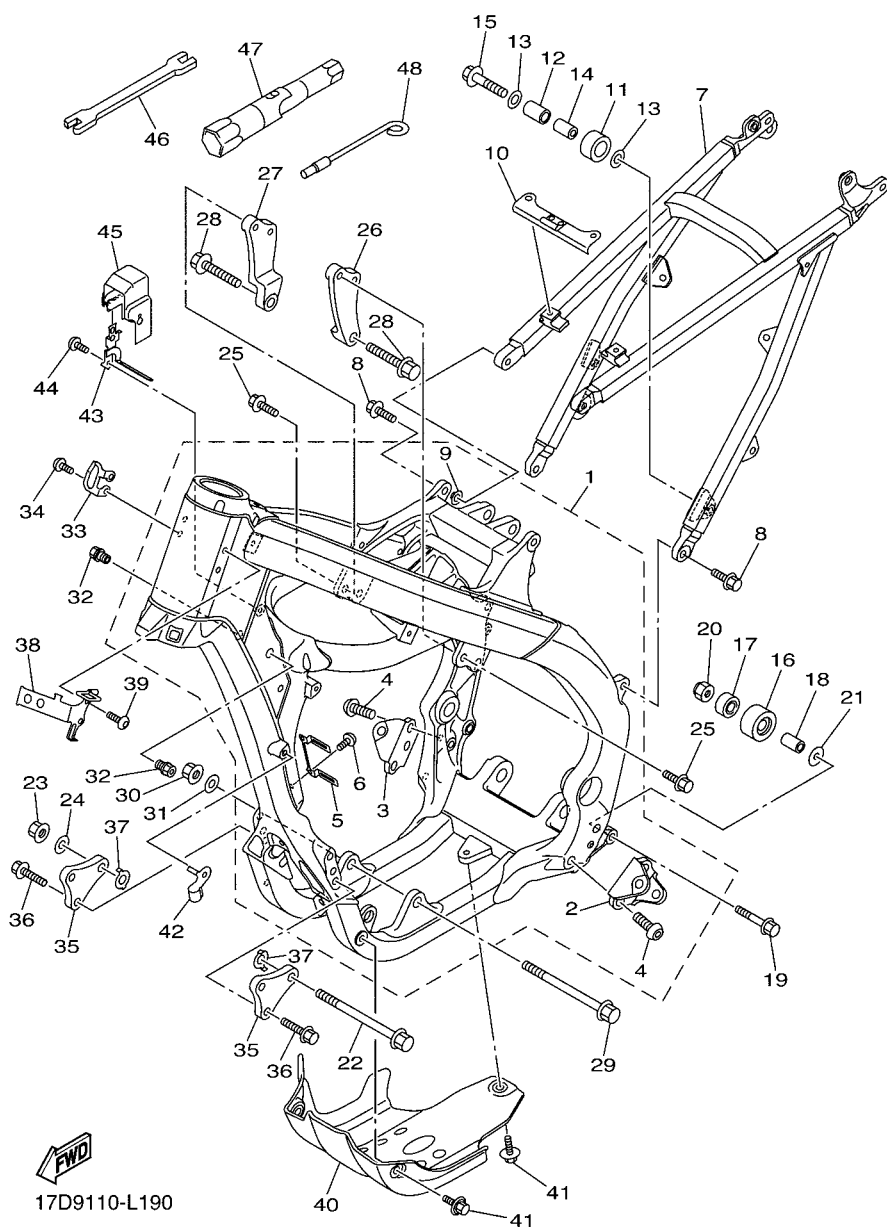
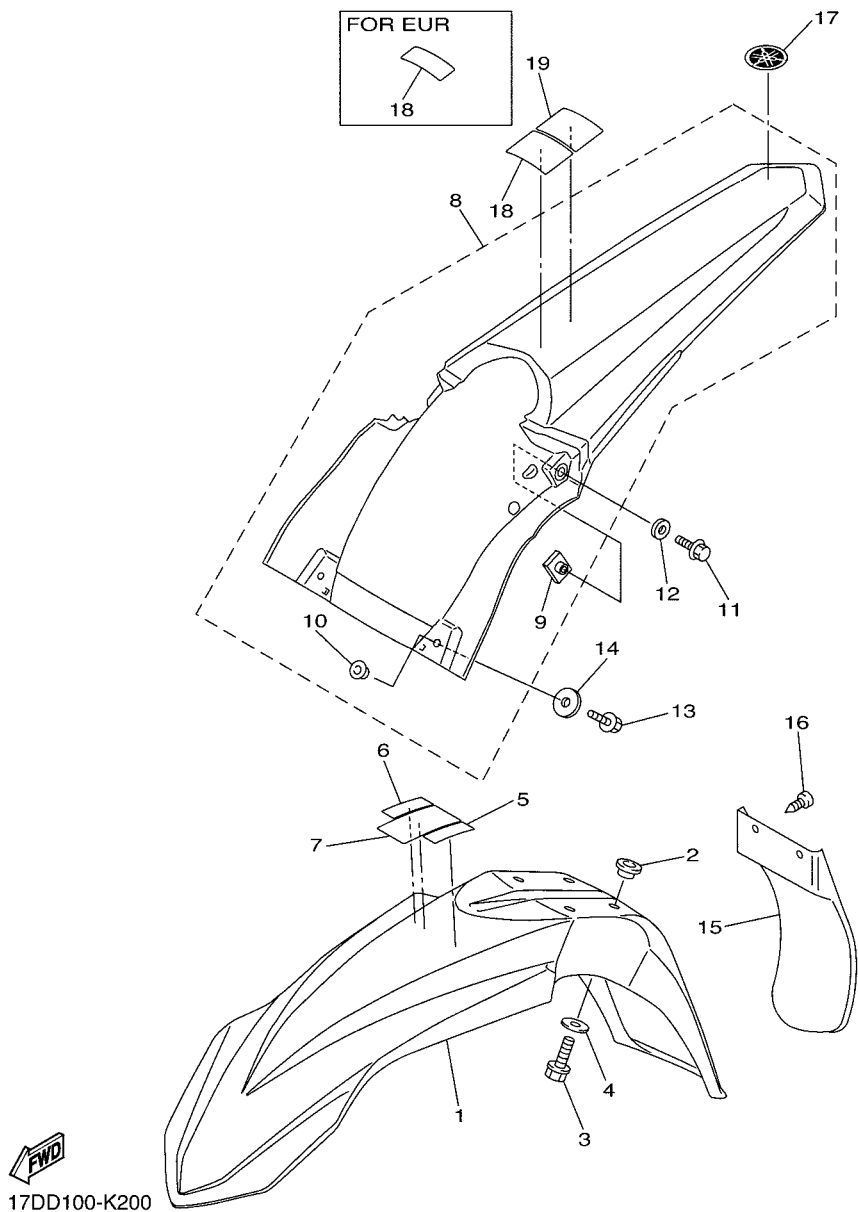

FIG. 19 FRAME

REF. NO.	PART NO.	DESCRIPTION	17D9	17DA	17DB	17DC	REMARKS
28	90105-10373	BOLT, FLANGE	2	2	2	2	
29	90105-10176	BOLT, FLANGE	1	1	1	1	
30	90179-10658	NUT	1	1	1	1	
31	90201-10045	WASHER, PLATE	1	1	1	1	
32	17D-21244-10	NUT	2	2	2	2	
33	17D-21163-50	HOLDER, CLUTCH CABLE	1	1	1	1	
34	92012-06010	BOLT, BUTTON HEAD	2	2	2	2	
35	17D-21417-51	BRACKET, FRONT LOWER 1	2	2	2	2	
36	90105-08143	BOLT, FLANGE	4	4	4	4	
37	5XC-21456-90	PLATE, PATCH	2	2	2	2	
38	17D-21274-50	BRACKET, C.D.I. UNIT	1	1	1	1	
39	92012-06010	BOLT, BUTTON HEAD	2	2	2	2	
40	17D-2147E-51	GUARD, ENGINE 2	1	1	1	1	
41	90119-06149	BOLT, WITH WASHER	3	3	3	3	
42	17D-21164-50	HOLDER, CABLE	1	1	1	1	
43	17D-23591-50	BRACKET 1	1	1	1	1	
44	92012-05008	BOLT, BUTTON HEAD	1	1	1	1	
45	17D-2117F-50	COVER	1	1	1	1	
46	5ET-28166-10	WRENCH, HEXAGON	1	1	1	1	
47	5TA-2814F-00	BOX, SPARK PLUG	1	1	1	1	
48	5XC-28116-00	TOOL, SPECIAL	1	1	1	1	





17DD100-K200

FIG. 20 FENDER

REF. NO.	PART NO.	DESCRIPTION	17D9	17DA	17DB	17DC	REMARKS
1	17D-21511-50	FENDER, FRONT	1	1	1	1	UR FOR DPBSE
	17D-21511-60	FENDER, FRONT	1	1	1	1	UR FOR PWS1
2	90387-06259	COLLAR	4	4	4	4	
3	90105-06127	BOLT, FLANGE	4	4	4	4	
4	90201-06108	WASHER, PLATE	4	4	4	4	
5	3FB-2415E-02	LABEL, CAUTION	1				
	3FB-2415E-C1	LABEL, CAUTION			1		JAPANESE
6	3FB-2415E-12	LABEL, CAUTION	1				
7	4SR-2416E-00	LABEL, CAUTION CANADA	1				
8	17D-21610-00	REAR FENDER COMP.	1	1	1	1	UR FOR DPBSE
	17D-21610-10	REAR FENDER COMP.	1	1	1	1	UR FOR PWS1
9	5XE-21635-10	.NUT, REAR FENDER	2	2	2	2	
10	90387-064X4	.COLLAR	2	2	2	2	
11	90105-06100	BOLT, FLANGE	2	2	2	2	
12	90201-06104	WASHER, PLATE	2	2	2	2	
13	90105-06106	BOLT, FLANGE	2	2	2	2	
14	90201-06085	WASHER, PLATE	2	2	2	2	
15	17D-21642-00	GUARD, FLAP	1	1	1	1	
16	97702-60016	SCREW, TAPPING	2	2	2	2	
17	3C5-2411B-20	EMBLEM	1	1	1	1	
18	5PA-2118K-00	LABEL, CAUTION	1			1	
	5PG-2816R-00	LABEL, WARNING GENERAL INFO.		1			
	5PA-2118K-20	LABEL, CAUTION			1		
19	5PA-2118K-10	LABEL, CAUTION	1				

**FIG. 21 SIDE COVER & OIL TANK**

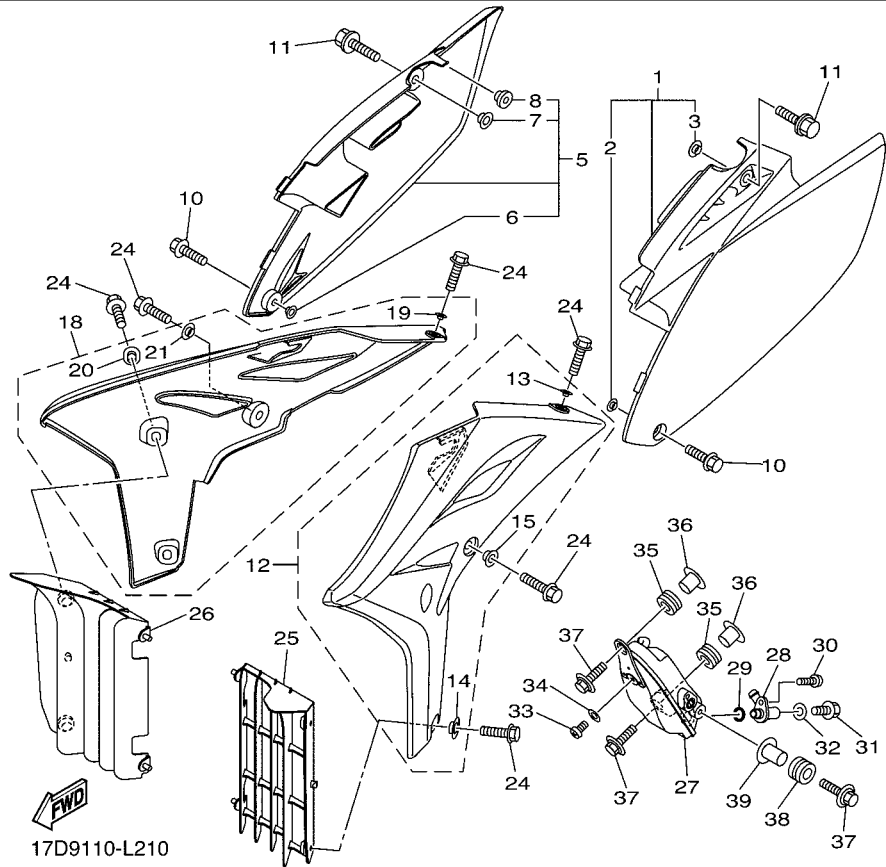
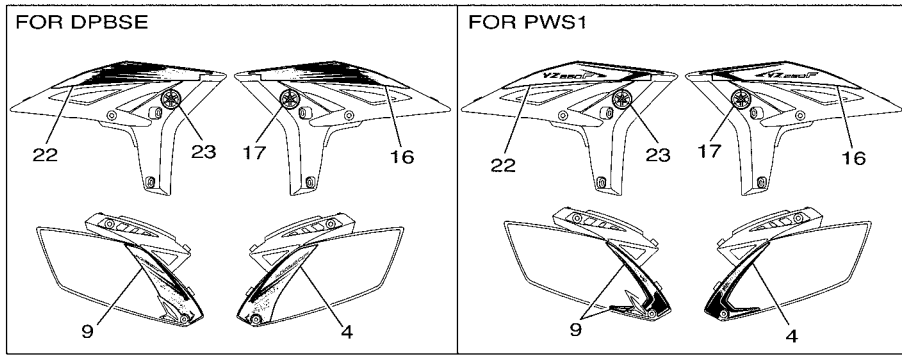

REF. NO.	PART NO.	DESCRIPTION	17D9	17DA	17DB	17DC	REMARKS
1	17D-21710-00	SIDE COVER ASSY 1	1	1	1	1	
2	90387-08086	.COLLAR	1	1	1	1	
3	5BE-21749-00	.COLLAR	1	1	1	1	
4	17D-2173E-20	GRAPHIC, 1	1	1	1	1	UR FOR DPBSE
	17D-2173E-30	GRAPHIC, 1	1	1	1	1	UR FOR PWS1
5	17D-21720-00	SIDE COVER ASSY 2	1	1	1	1	
6	90387-08086	.COLLAR	1	1	1	1	
7	5BE-21749-00	.COLLAR	1	1	1	1	
8	5XC-21719-90	.GROMMET	2	2	2	2	
9	17D-2173F-20	GRAPHIC, 2	1	1	1	1	UR FOR DPBSE
	17D-2174L-10	GRAPHIC SET 2	1	1	1	1	UR FOR PWS1
10	90105-06103	BOLT, FLANGE	2	2	2	2	
11	90119-08095	BOLT, WITH WASHER	2	2	2	2	
12	17D-21730-D0	SIDE COVER ASSY 3	1	1	1	1	UR FOR DPBSE
	17D-21730-10	SIDE COVER ASSY 3	1	1	1	1	UR FOR PWS1
13	90387-06009	.COLLAR	1	1	1	1	
14	17D-21749-00	.COLLAR	2	2	2	2	
15	5BE-21749-00	.COLLAR	1	1	1	1	
16	17D-2174G-30	GRAPHIC, 3	1	1	1	1	UR FOR DPBSE
	17D-2174G-40	GRAPHIC, 3	1	1	1	1	UR FOR PWS1
17	5FK-2175C-00	TUNING FORK MARK	1	1	1	1	
18	17D-21740-D0	SIDE COVER ASSY 4	1	1	1	1	UR FOR DPBSE
	17D-21740-10	SIDE COVER ASSY 4	1	1	1	1	UR FOR PWS1
19	90387-06009	.COLLAR	1	1	1	1	
20	17D-21749-00	.COLLAR	2	2	2	2	
21	5BE-21749-00	.COLLAR	1	1	1	1	
22	17D-2174H-30	GRAPHIC, 4	1	1	1	1	UR FOR DPBSE

**FIG. 21 SIDE COVER & OIL TANK**

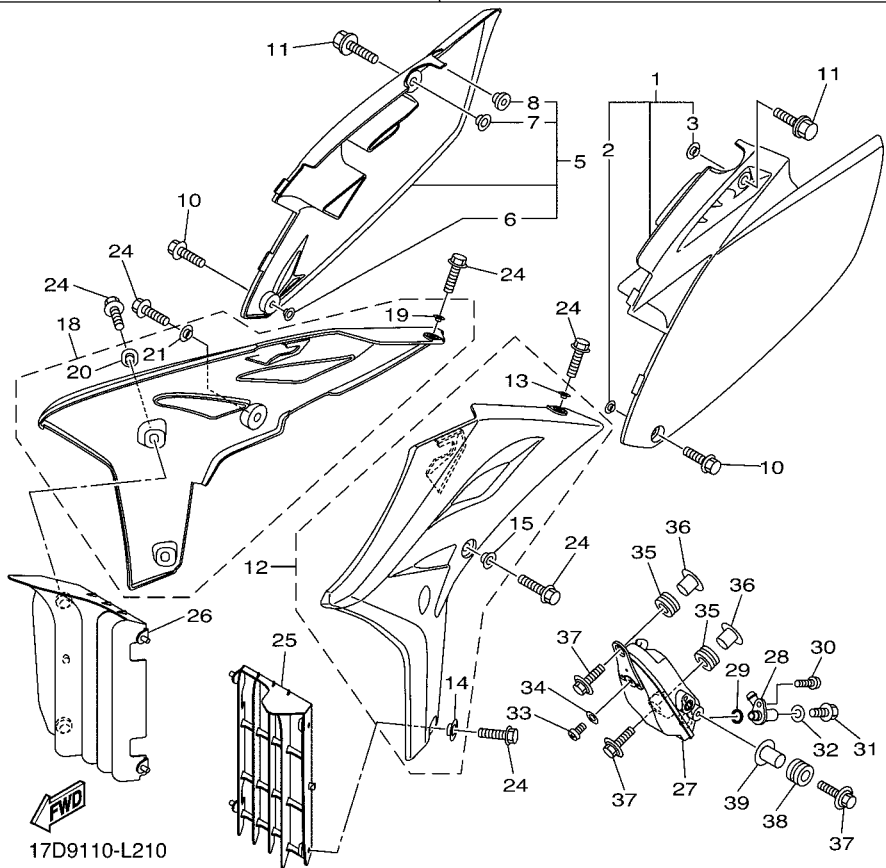
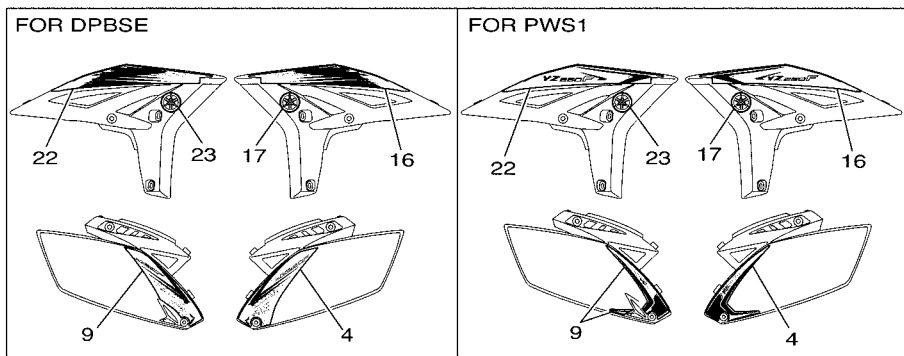

REF. NO.	PART NO.	DESCRIPTION	17D9	17DA	17DB	17DC	REMARKS
22	17D-2174H-40	GRAPHIC, 4	1	1	1	1	UR FOR PWS1
23	5FK-2175C-00	TUNING FORK MARK	1	1	1	1	
24	90105-06064	BOLT, FLANGE	8	8	8	8	
25	17D-2172A-00	PANEL 1	1	1	1	1	
26	17D-2172A-10	PANEL 1	1	1	1	1	
27	17D-21751-00	TANK, OIL	1	1	1	1	
28	17D-13416-00	PIPE, OIL 1	1	1	1	1	
29	93210-14369	O-RING	1	1	1	1	
30	92012-06016	BOLT, BUTTON HEAD	1	1	1	1	
31	90105-08151	BOLT, FLANGE	1	1	1	1	
32	90201-082A6	WASHER, PLATE	1	1	1	1	
33	98902-06012	SCREW, BIND	1	1	1	1	
34	90201-06630	WASHER, PLATE	1	1	1	1	
35	90480-10289	GROMMET	2	2	2	2	
36	90387-06150	COLLAR	2	2	2	2	
37	90119-06255	BOLT, WITH WASHER	3	3	3	3	
38	90480-14433	GROMMET	1	1	1	1	
39	90387-06161	COLLAR	1	1	1	1	

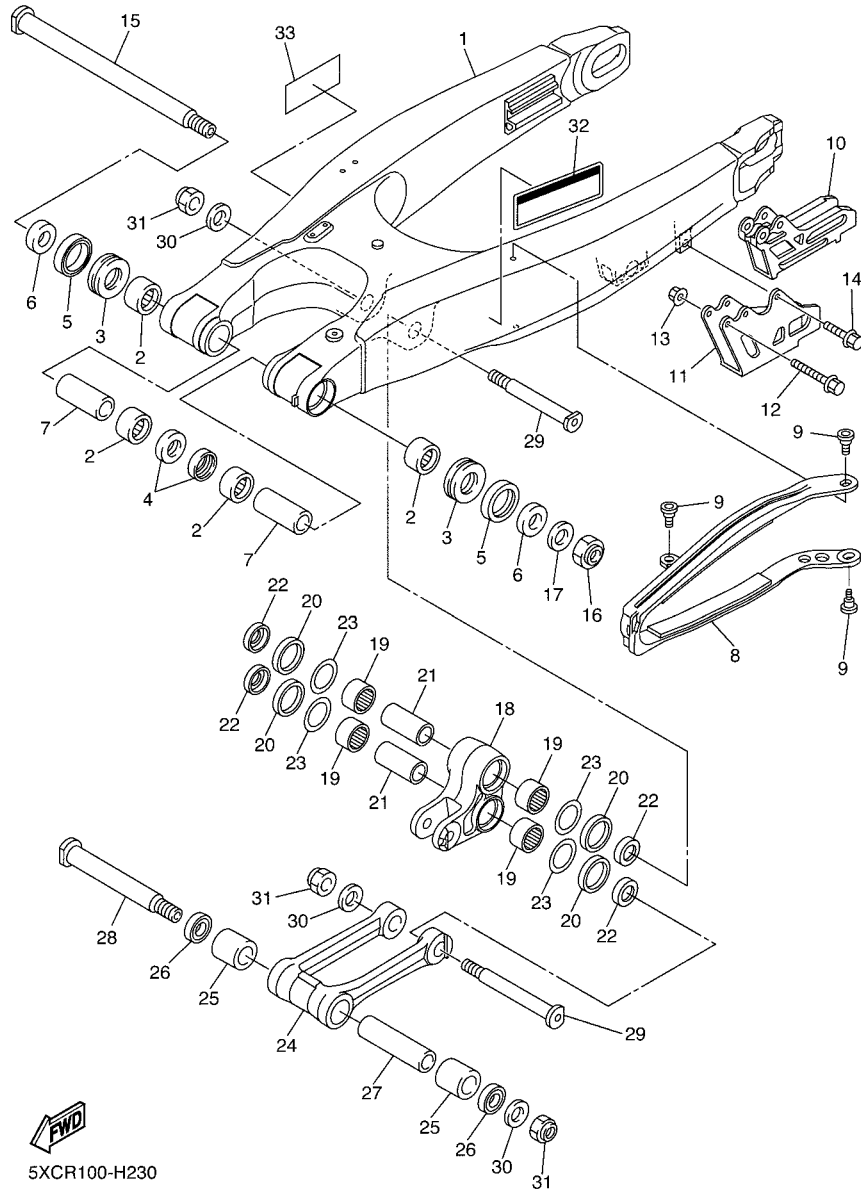

5XCR100-H230

FIG. 22 REAR ARM

REF. NO.	PART NO.	DESCRIPTION	17D9	17DA	17DB	17DC	REMARKS
1	17D-22110-90	REAR ARM COMP.	1	1	1	1	
2	93317-22262	BEARING	4	4	4	4	
3	93342-22217	BEARING	2	2	2	2	
4	93106-22002	OIL SEAL	2	2	2	2	
5	93109-28043	OIL SEAL	2	2	2	2	
6	90387-18012	COLLAR	2	2	2	2	
7	90387-18004	COLLAR	2	2	2	2	
8	34P-22151-01	SEAL, GUARD	1	1	1	1	
9	1C3-22969-90	SCREW, 1	3	3	3	3	
10	2S2-22199-70	SUPPORT, CHAIN	1	1	1	1	
11	2S2-22128-70	COVER, THRUST 1	1	1	1	1	
12	90105-06104	BOLT, FLANGE	2	2	2	2	
13	95702-06500	NUT, FLANGE	2	2	2	2	
14	90105-06105	BOLT, FLANGE	1	1	1	1	
15	17D-22141-50	SHAFT, PIVOT	1	1	1	1	
16	90185-16002	NUT, SELF-LOCKING	1	1	1	1	
17	90201-16018	WASHER, PLATE	1	1	1	1	
18	17D-2217A-00	ARM, RELAY	1	1	1	1	
19	93315-32166	BEARING	4	4	4	4	
20	93109-25001	OIL SEAL	4	4	4	4	
21	90387-16026	COLLAR	2	2	2	2	
22	90209-16011	WASHER	4	4	4	4	
23	90201-21014	WASHER, PLATE	4	4	4	4	
24	17D-2217F-50	ROD, CONNECTING 1	1	1	1	1	
25	93315-32269	BEARING	2	2	2	2	
26	93109-22019	OIL SEAL	2	2	2	2	
27	90387-14009	COLLAR	1	1	1	1	



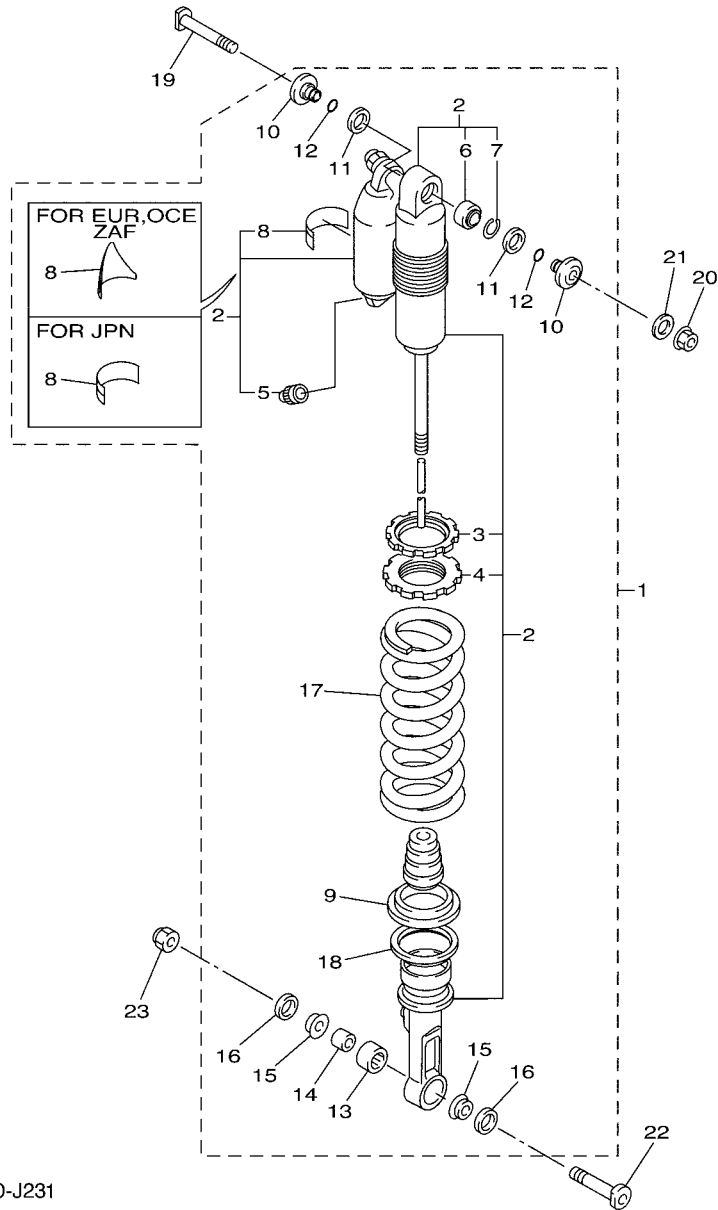

17D5100-J231

FIG. 23 REAR SUSPENSION

REF. NO.	PART NO.	DESCRIPTION	17D9	17DA	17DB	17DC	REMARKS
1	17D-22200-B0	SHOCK ABSORBER ASSY, REAR	1				UR FOR DPBSE
	17D-22200-F0	SHOCK ABSORBER ASSY, REAR	1				UR FOR PWS1
	17D-22200-90	SHOCK ABSORBER ASSY, REAR		1	1		UR FOR DPBSE
	17D-22200-D0	SHOCK ABSORBER ASSY, REAR		1	1		UR FOR PWS1
	17D-22200-A0	SHOCK ABSORBER ASSY, REAR			1		UR FOR DPBSE
	17D-22200-E0	SHOCK ABSORBER ASSY, REAR			1		UR FOR PWS1
2	17D-22201-70	.DAMPER SUB ASSY	1				
	17D-22201-50	.DAMPER SUB ASSY		1	1		
	17D-22201-60	.DAMPER SUB ASSY			1		
3	3SP-22234-00	..GUIDE, SPRING 3	1	1	1	1	
4	1C3-22213-L0	..SEAT, SPRING UPPER	1	1	1	1	
5	509-23184-L0	..CAP, AIR VALVE	1	1	1	1	
6	4JX-22226-00	..BUSH, SHOCK ABSORBER LOWER	1	1	1	1	
7	5DH-23183-00	..CIRCLIP	1	1	1	1	
8	4AA-22259-70	..LABEL, WARNING	1				
	4AA-22259-40	..LABEL, WARNING		1		1	
	4AA-22259-50	..LABEL, WARNING			1		
9	5MV-22224-00	.GUIDE, SPRING 2	1	1	1	1	
10	1C3-22253-50	.COLLAR, DISTANCE	2	2	2	2	
11	3JE-22475-00	.SEAL, DUST	2	2	2	2	
12	4EW-22474-00	.SEAL, RING	2	2	2	2	
13	5UN-22176-00	.BEARING	1	1	1	1	
14	5MV-22184-00	.BUSH	1	1	1	1	
15	1C3-22253-L1	.COLLAR, DISTANCE	2	2	2	2	
16	5NY-22475-00	.SEAL, DUST	2	2	2	2	
17	5UN-22212-L0	.SPRING (K=52N/MM)	1	1	1	1	UR FOR DPBSE
	5UN-22212-K0	.SPRING (K=52N/MM)	1	1	1	1	UR FOR PWS1





FIG. 24 STEERING

REF. NO.	PART NO.	DESCRIPTION	17D9	17DA	17DB	17DC	REMARKS
1	90387-06105	COLLAR	1	1	1	1	
2	93332-00068	BEARING	1	1	1	1	
3	17D-23416-50	COVER, BALL RACE 2	1	1	1	1	
4	90179-28016	NUT	1	1	1	1	
5	90201-286K9	WASHER, PLATE (T1.0)	1	1	1	1	
6	33D-23435-00	CROWN, HANDLE	1	1	1	1	
7	90179-24004	NUT	1	1	1	1	
8	18P-23441-00	HOLDER, HANDLE UPPER	2	2	2	2	
9	17D-23442-10	HOLDER, HANDLE LOWER	2	2	2	2	
10	92902-10200	WASHER	2	2	2	2	
11	95602-10200	NUT, U FLANGE	2	2	2	2	
12	90105-08154	BOLT, FLANGE	8	8	8	8	
13	17D-23485-50	PLATE, NUMBER	1	1	1	1	
14	90105-06064	BOLT, FLANGE	1	1	1	1	
15	17D-2339E-20	GRAPHIC 1	1	1	1	1	FOR PWS1
16	17D-23389-50	GUIDE, CABLE	1	1	1	1	
17	90105-06170	BOLT, FLANGE	1	1	1	1	
18	93332-00081	BEARING	1	1	1	1	

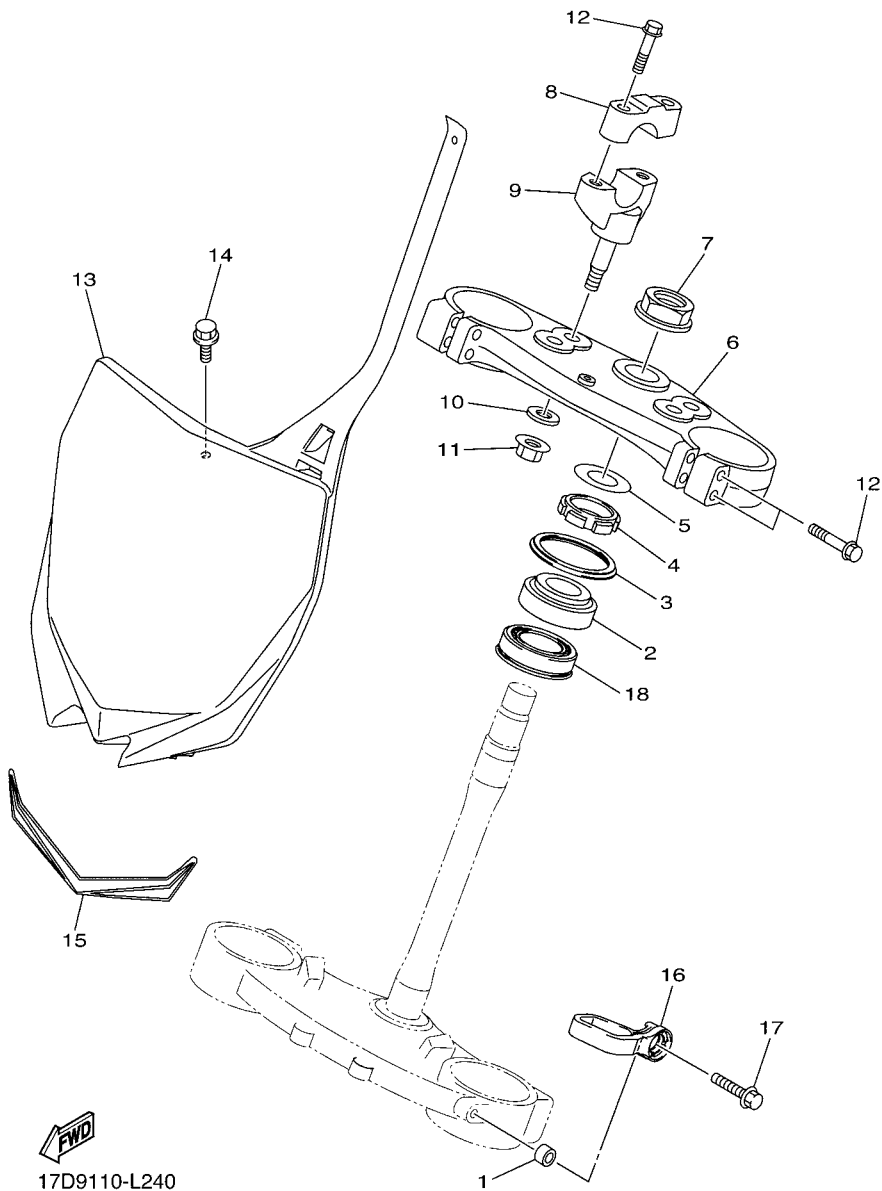

17D9110-L240

FIG. 25 FRONT FORK

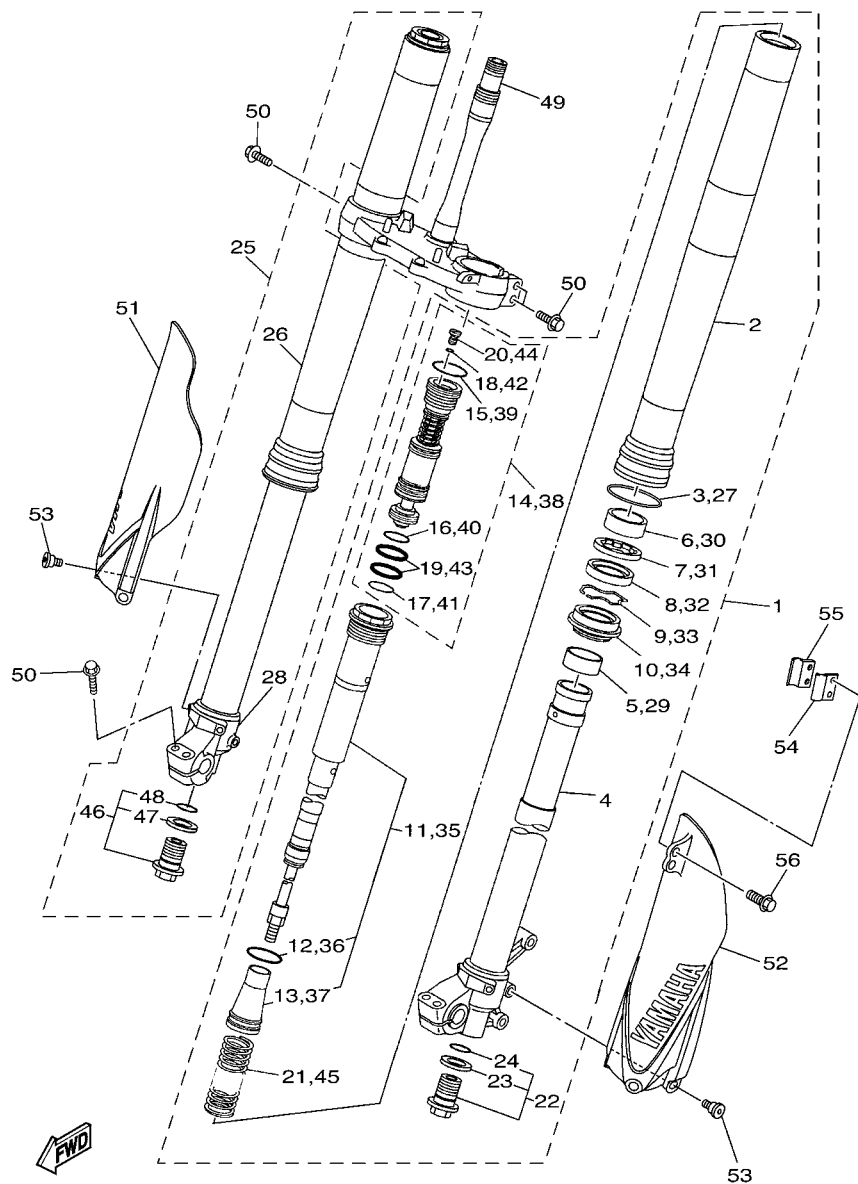

17D9110-L250

REF. NO.	PART NO.	DESCRIPTION	17D9	17DA	17DB	17DC	REMARKS
1	17D-23102-20	FRONT FORK ASSY (L.H)	1	1	1	1	
2	33D-23136-00	.TUBE, OUTER (RIGHT)	1	1	1	1	
3	17D-23153-00	.RING, SNAP	1	1	1	1	
4	17D-23120-10	.INNER TUBE COMP.2	1	1	1	1	
5	5XE-23171-L0	.PISTON, FRONT FORK	1	1	1	1	
6	5XE-23125-L0	.METAL, SLIDE 1	1	1	1	1	
7	5XC-23146-10	.WASHER, OIL SEAL	1	1	1	1	
8	17D-23145-00	.OIL SEAL	1	1	1	1	
9	5XE-23153-L0	.RING, SNAP	1	1	1	1	
10	5XE-23144-L0	.SEAL, DUST	1	1	1	1	
11	17D-23170-20	.CYLINDER COMP., FRONT FORK	1	1	1	1	
12	1C3-23147-L0	..O-RING	1	1	1	1	
13	17D-23142-00	..SEAT, SPRING UPPER	1	1	1	1	
14	17D-2316A-20	.VALVE COMP.	1	1	1	1	
15	1C3-23188-L0	..O-RING	1	1	1	1	
16	1C3-23188-N0	..O-RING	1	1	1	1	
17	1C3-23188-P0	..O-RING	1	1	1	1	
18	1C3-23188-R0	..O-RING	1	1	1	1	
19	1AE-23147-00	..O-RING	2	2	2	2	
20	1C3-23190-L0	..AIR VALVE COMP.	1	1	1	1	
21	2S2-23141-M1	.SPRING, FRONT FORK(K=4.5N/MM)	1	1	1	1	
22	5XC-23111-00	.BOLT, CAP	1	1	1	1	
23	2HH-23158-L0	..GASKET	1	1	1	1	
24	276-23114-00	..GASKET	1	1	1	1	
25	17D-23103-20	FRONT FORK ASSY (R.H)	1	1	1	1	
26	33D-23136-00	.TUBE, OUTER (RIGHT)	1	1	1	1	
27	17D-23153-00	.RING, SNAP	1	1	1	1	

FIG. 25 FRONT FORK

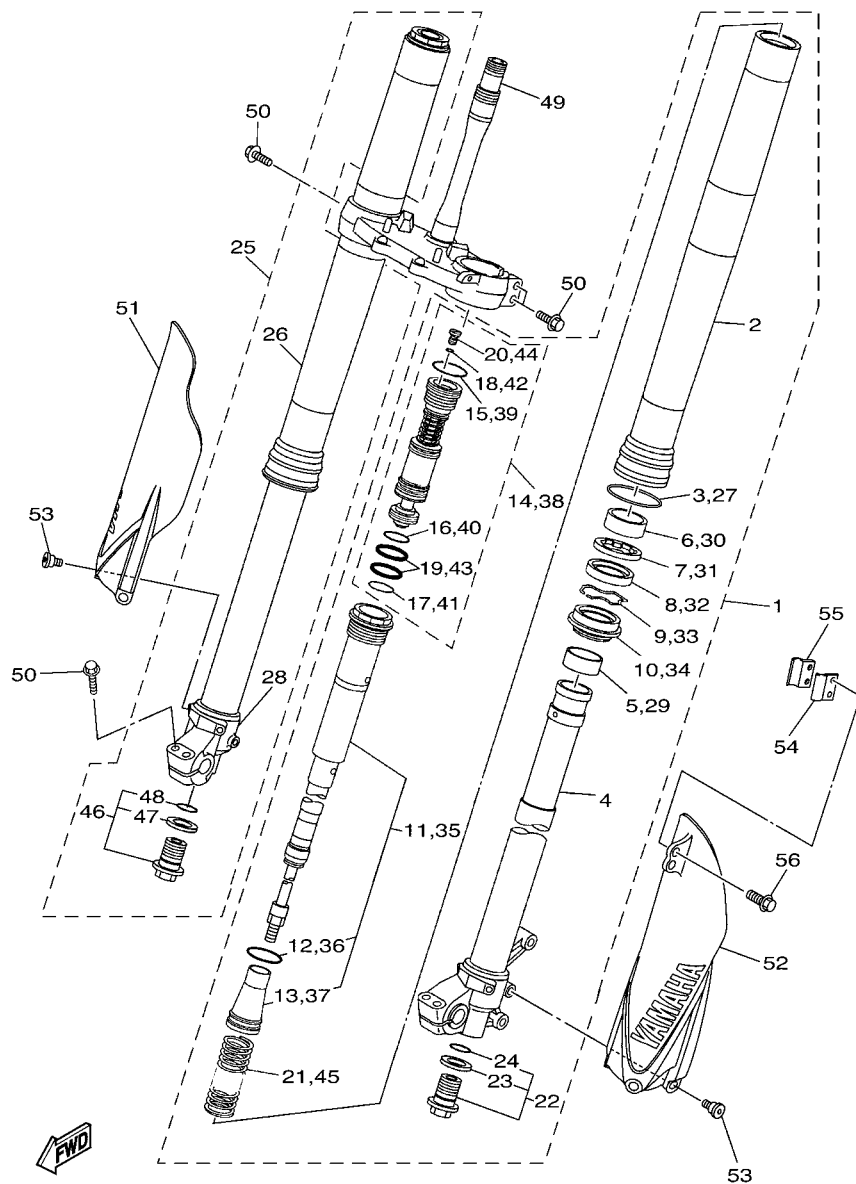

17D9110-L250

REF. NO.	PART NO.	DESCRIPTION	17D9	17DA	17DB	17DC	REMARKS
28	17D-23110-10	.INNER TUBE COMP.1	1	1	1	1	
29	5XE-23171-L0	.PISTON, FRONT FORK	1	1	1	1	
30	5XE-23125-L0	.METAL, SLIDE 1	1	1	1	1	
31	5XC-23146-10	.WASHER, OIL SEAL	1	1	1	1	
32	17D-23145-00	.OIL SEAL	1	1	1	1	
33	5XE-23153-L0	.RING, SNAP	1	1	1	1	
34	5XE-23144-L0	.SEAL, DUST	1	1	1	1	
35	17D-23170-20	.CYLINDER COMP., FRONT FORK	1	1	1	1	
36	1C3-23147-L0	..O-RING	1	1	1	1	
37	17D-23142-00	..SEAT, SPRING UPPER	1	1	1	1	
38	17D-2316A-20	.VALVE COMP.	1	1	1	1	
39	1C3-23188-L0	..O-RING	1	1	1	1	
40	1C3-23188-N0	..O-RING	1	1	1	1	
41	1C3-23188-P0	..O-RING	1	1	1	1	
42	1C3-23188-R0	..O-RING	1	1	1	1	
43	1AE-23147-00	..O-RING	2	2	2	2	
44	1C3-23190-L0	..AIR VALVE COMP.	1	1	1	1	
45	2S2-23141-M1	.SPRING, FRONT FORK(K=4.5N/MM)	1	1	1	1	
46	5XC-23111-00	.BOLT, CAP	1	1	1	1	
47	2HH-23158-L0	..GASKET	1	1	1	1	
48	276-23114-00	..GASKET	1	1	1	1	
49	33D-23340-00	UNDER BRACKET COMP.	1	1	1	1	
50	90105-08154	BOLT, FLANGE	8	8	8	8	
51	17D-2315J-50	PROTECTOR 2	1	1	1	1	
52	17D-2315H-50	PROTECTOR 1	1	1	1	1	
53	90109-06232	BOLT	6	6	6	6	
54	17D-23466-00	CLAMP	1	1	1	1	



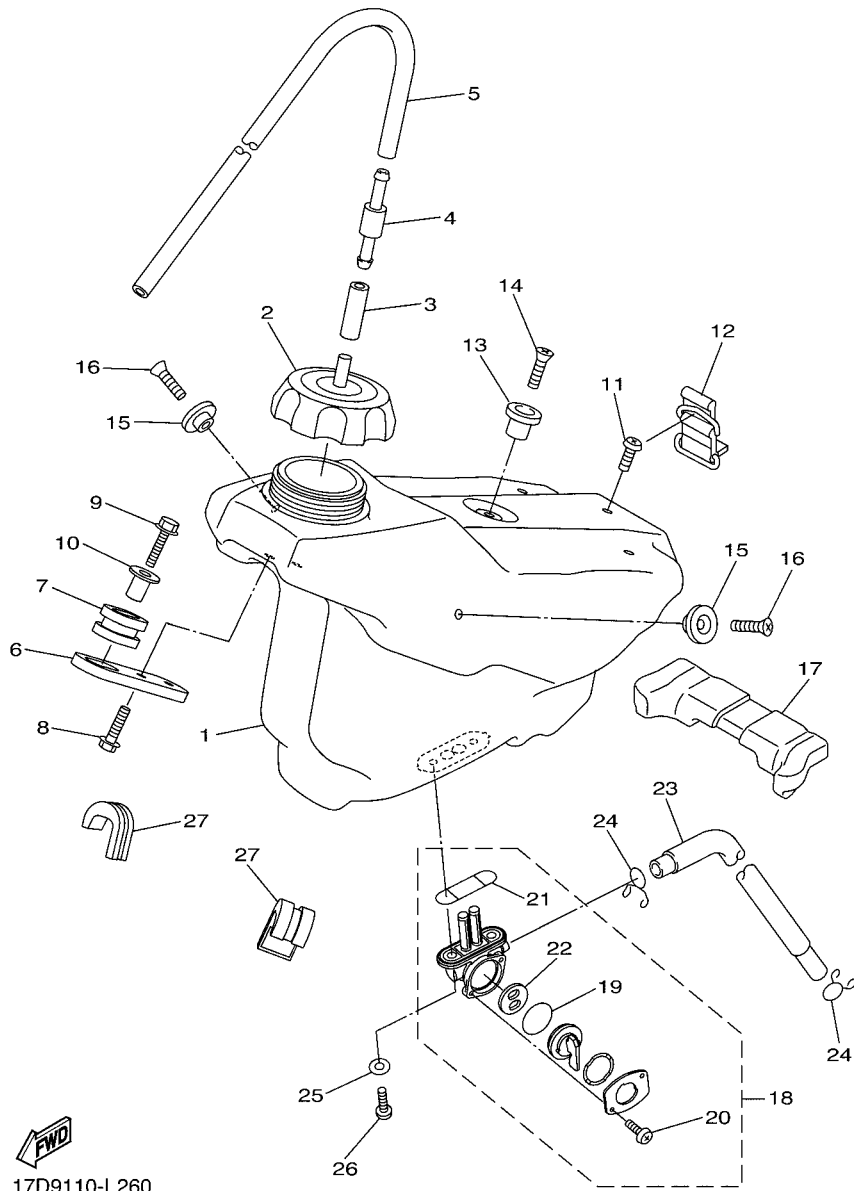

17D9110-L260

FIG. 26 FUEL TANK

REF. NO.	PART NO.	DESCRIPTION	17D9	17DA	17DB	17DC	REMARKS
1	17D-24110-50	FUEL TANK COMP.	1	1	1	1	
2	5NY-24610-10	CAP ASSY	1	1	1	1	
3	90445-09003	HOSE (L30)	1	1	1	1	
4	3XJ-24380-00	PIPE JOINT ASSY	1	1	1	1	
5	90445-09005	HOSE	1	1	1	1	
6	17D-24144-00	HOLDER, DAMPER	1	1	1	1	
7	90480-17008	GROMMET	1	1	1	1	
8	90105-06107	BOLT, FLANGE	2	2	2	2	
9	90105-06111	BOLT, FLANGE	1	1	1	1	
10	3JD-24186-00	WASHER, SPECIAL	1	1	1	1	
11	98902-06025	SCREW, BIND	1	1	1	1	
12	5SF-24173-00	BAND, TANK FITTING 1	1	1	1	1	
13	4EW-2412F-00	BRACKET, SEAT	1	1	1	1	
14	98707-06025	SCREW, FLAT HEAD	1	1	1	1	
15	17D-2412F-00	BRACKET, SEAT	2	2	2	2	
16	98702-06020	SCREW, FLAT HEAD	2	2	2	2	
17	17D-24181-50	DAMPER, LOCATING 1	1	1	1	1	
18	4DP-24500-10	FUEL COCK ASSY 1	1	1	1	1	
19	3AJ-24534-10	.SEAL, COCK	1	1	1	1	
20	98507-03008	.SCREW, PAN HEAD	2	2	2	2	
21	4X8-24512-10	.GASKET	1	1	1	1	
22	3AC-24523-00	.VALVE PACKING	1	1	1	1	
23	90445-11059	HOSE	1	1	1	1	
24	90467-100A1	CLIP	2	2	2	2	
25	90202-05193	WASHER, PLATE	2	2	2	2	
26	90149-06108	SCREW	2	2	2	2	
27	17D-24182-50	DAMPER, LOCATING 2	2	2	2	2	



FIG. 28 FRONT WHEEL

REF. NO.	PART NO.	DESCRIPTION	17D9	17DA	17DB	17DC	REMARKS
1	5NY-25111-00	HUB, FRONT	1	1	1	1	
2	93306-90409	BEARING	2	2	2	2	
3	5NY-25117-00	SPACER, BEARING	1	1	1	1	
4	93102-26468	OIL SEAL	2	2	2	2	
5	94416-21045	RIM (1.60-21)	1	1	1	1	
6	17D-2531B-00	.EMBLEM, WHEEL	2	2	2	2	
7	5NY-25104-00	SPOKE SET, FRONT	1	1	1	1	
8	5NY-25196-00	.SPOKE, INNER 1			36		
9	56A-25195-00	.NIPPLE, SPOKE			36		
10	94108-21027	TIRE (80/100-21 51M)	1			1	BRIDGESTONE
*		TIRE (80/100-21 51R MST)		1			LM PIRELLI
*		TIRE (80/100-21 51M MX51FG)			1		LM DUNLOP
11	94209-21229	TUBE (80/100-21 M/C TR4)	1			1	BRIDGESTONE
*		TUBE (80/100-21)		1			LM PIRELLI
*		TUBE (80/100-21 M/C TR4)			1		LM DUNLOP
12	94330-21084	BAND,RIM (1.60-21)	1			1	BRIDGESTONE
*		BAND, RIM (80/100-21)		1			LM PIRELLI
*		BAND, RIM (22-21)			1		LM DUNLOP
13	5SF-25394-00	SPACER, BEAD	1	1	1	1	
14	5XC-25181-G0	AXLE, WHEEL	1	1	1	1	
15	5XC-25183-G0	COLLAR, WHEEL	1	1	1	1	
16	5XC-25186-G0	COLLAR, WHEEL	1	1	1	1	
17	90179-16011	NUT	1	1	1	1	

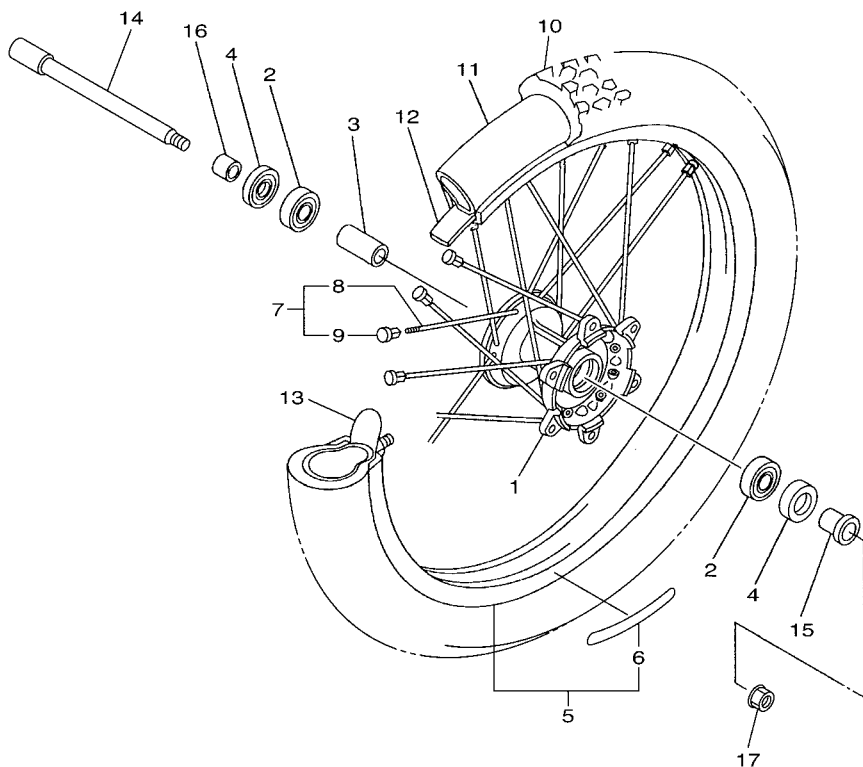

17DD100-K280



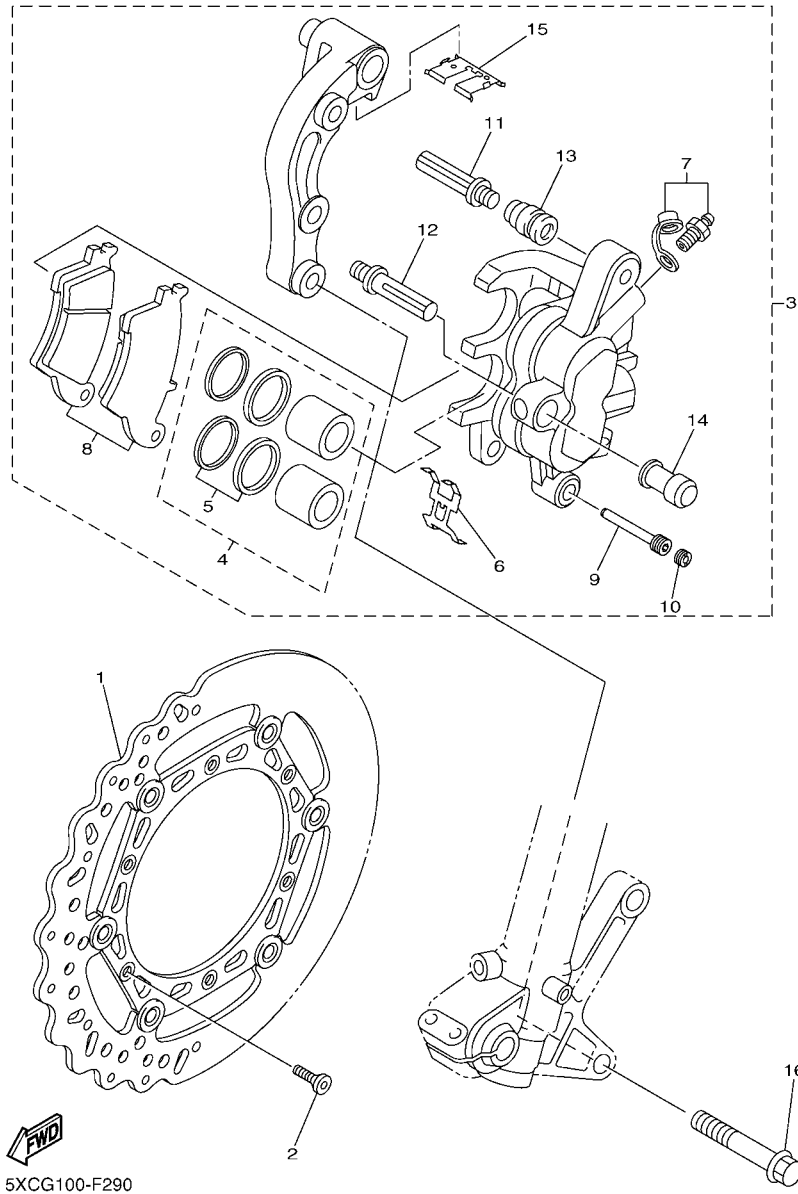

5XCG100-F290

FIG. 29 FRONT BRAKE CALIPER

REF. NO.	PART NO.	DESCRIPTION	17D9	17DA	17DB	17DC	REMARKS
1	5XC-2581T-G0	DISK BRAKE ASSY	1	1	1	1	
2	90151-06051	SCREW, COUNTERSUNK	6	6	6	6	
3	5XC-2580T-G0	CALIPER ASSY (LEFT)	1	1	1	1	
4	5XC-W0057-00	.PISTON ASSY, CALIPER	1	1	1	1	
5	5KM-W0047-10	..CALIPER SEAL KIT	1	1	1	1	
6	5DH-25919-00	.SUPPORT, PAD	1	1	1	1	
7	1UY-W0048-50	.BLEED SCREW KIT	1	1	1	1	
8	5XC-W0045-00	.BRAKE PAD KIT	1	1	1	1	
9	5DH-25933-00	.PIN, PAD	1	1	1	1	
10	5DH-25916-00	.PLUG	1	1	1	1	
11	3SP-25926-51	.BOLT	1	1	1	1	
12	3SP-25914-51	.PIN, SLIDE	1	1	1	1	
13	3JD-25917-00	.BOOT, CALIPER	1	1	1	1	
14	1UY-25937-51	.BOOT 2	1	1	1	1	
15	5XC-25849-G0	.RETAINER, CALIPER	1	1	1	1	
16	90105-08137	BOLT, FLANGE	2	2	2	2	

FIG. 30 REAR WHEEL

REF. NO.	PART NO.	DESCRIPTION	17D9	17DA	17DB	17DC	REMARKS
1	17D-25311-00	HUB, REAR	1	1	1	1	
2	17D-25317-00	SPACER, BEARING	1	1	1	1	
3	93306-90510	BEARING	3	3	3	3	
4	93102-32337	OIL SEAL	2	2	2	2	
5	99009-42700	CIRCLIP	1	1	1	1	
6	17D-25450-50	SPROCKET, DRIVEN (50T)	1				STD
	17D-25451-50	SPROCKET, DRIVEN (51T)		1	1	1	STD
	17D-25447-50	SPROCKET, DRIVEN (47T)	1	1	1	1	AP
	17D-25448-50	SPROCKET, DRIVEN (48T)	1	1	1	1	AP
	17D-25449-50	SPROCKET, DRIVEN (49T)	1	1	1	1	AP
	17D-25452-50	SPROCKET, DRIVEN (52T)	1	1	1	1	AP
	17D-25451-50	SPROCKET, DRIVEN (51T)	1				AP
	17D-25450-50	SPROCKET, DRIVEN (50T)		1	1	1	AP
7	90109-08078	BOLT	6	6	6	6	
8	90185-08008	NUT, SELF-LOCKING	6	6	6	6	
9	90201-08048	WASHER, PLATE	6	6	6	6	
10	34P-25304-00	SPOKE SET, REAR	1	1	1	1	
11	34P-25396-00	.SPOKE, INNER 2			18		
12	34P-25397-00	.SPOKE, OUTER 2			18		
13	5ET-25395-00	.NIPPLE, SPOKE			36		
14	94418-19036	RIM (1.85-19)	1	1	1	1	
15	17D-2531B-00	.EMBLEM, WHEEL	2	2	2	2	
16	94110-19019	TIRE (100/90-19 57M M404)	1			1	BRIDGESTONE
	*	TIRE (100/90-19 57M NHS)		1			LM PIRELLI
	*	TIRE			1		LM DUNLOP
17	94210-19222	TUBE (100/90-19 M/C TR4)	1			1	BRIDGESTONE
	*	TUBE (110/90-19)		1			LM PIRELLI

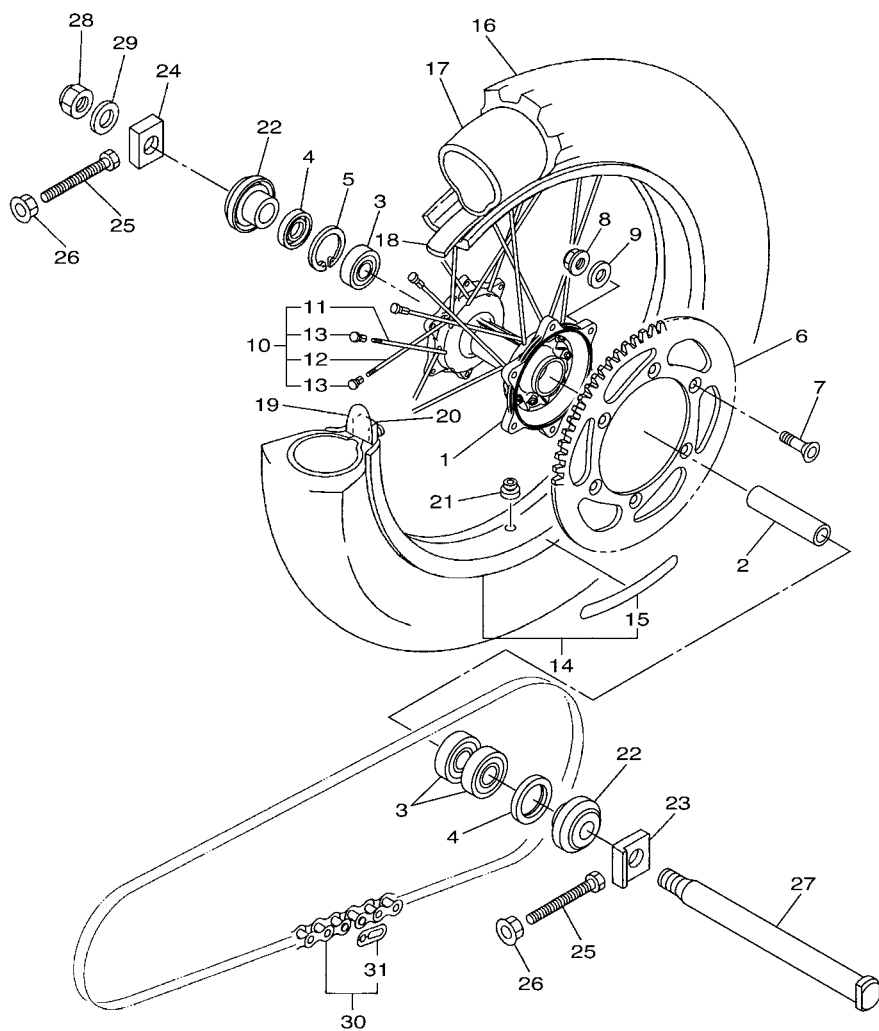

17DD100-K300

**FIG. 30 REAR WHEEL**

REF. NO.	PART NO.	DESCRIPTION	17D9	17DA	17DB	17DC	REMARKS
17	*	TUBE (100/90-19 M/C TR4 BTL)			1		LM DUNLOP
18	94316-19156	BAND, RIM (1.85-19)	1			1	BRIDGESTONE
	*	BAND, RIM (3.50-18)		1			LM METZELER
	*	BAND, RIM (22-19)			1		LM DUNLOP
19	4XM-25394-00	SPACER, BEAD	1	1	1	1	
20	4XM-25364-00	DAMPER	1	1	1	1	
21	90480-08608	GROMMET	1	1	1	1	
22	17D-2530S-00	COLLAR ASSY	2	2	2	2	
23	17D-25388-00	PULLER, CHAIN 1	1	1	1	1	
24	33D-25389-00	PULLER, CHAIN 2	1	1	1	1	
25	90101-08006	BOLT	2	2	2	2	
26	90179-08019	NUT	2	2	2	2	
27	17D-25381-00	AXLE, WHEEL	1	1	1	1	
28	90185-22011	NUT, SELF-LOCKING	1	1	1	1	
29	90201-22023	WASHER, PLATE	1	1	1	1	
30	9Y582-28113	CHAIN (DID520DMA2-114LL)	1	1			
	9Y581-92113	CHAIN (DID520DMA2 SDH 114LL)			1	1	UR FOR DPBSE
	9Y582-28113	CHAIN (DID520DMA2-114LL)			1	1	UR FOR PWS1
31	94682-28001	.JOINT, CHAIN (DID520DM G&B-RJ)	1	1			
	94681-68001	.JOINT,CHAIN (DID 520DM-RJ)			1	1	UR FOR DPBSE
	94682-28001	.JOINT, CHAIN (DID520DM G&B-RJ)			1	1	UR FOR PWS1

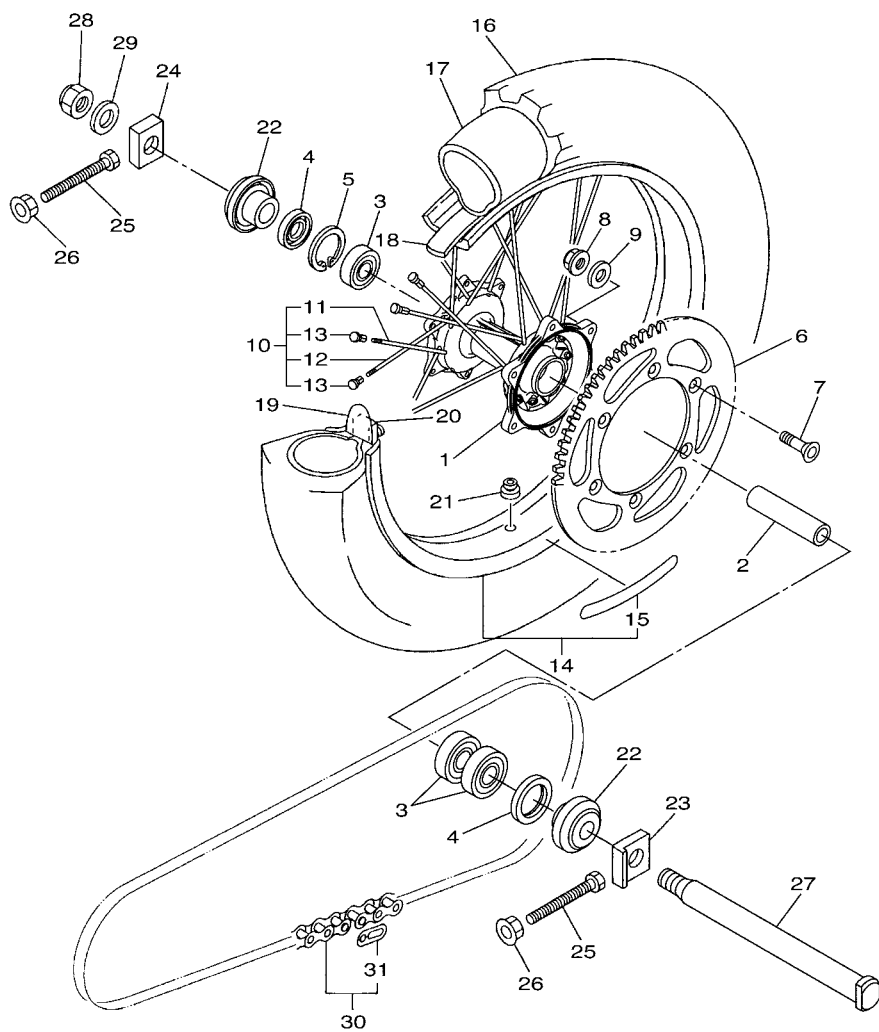

17DD100-K300

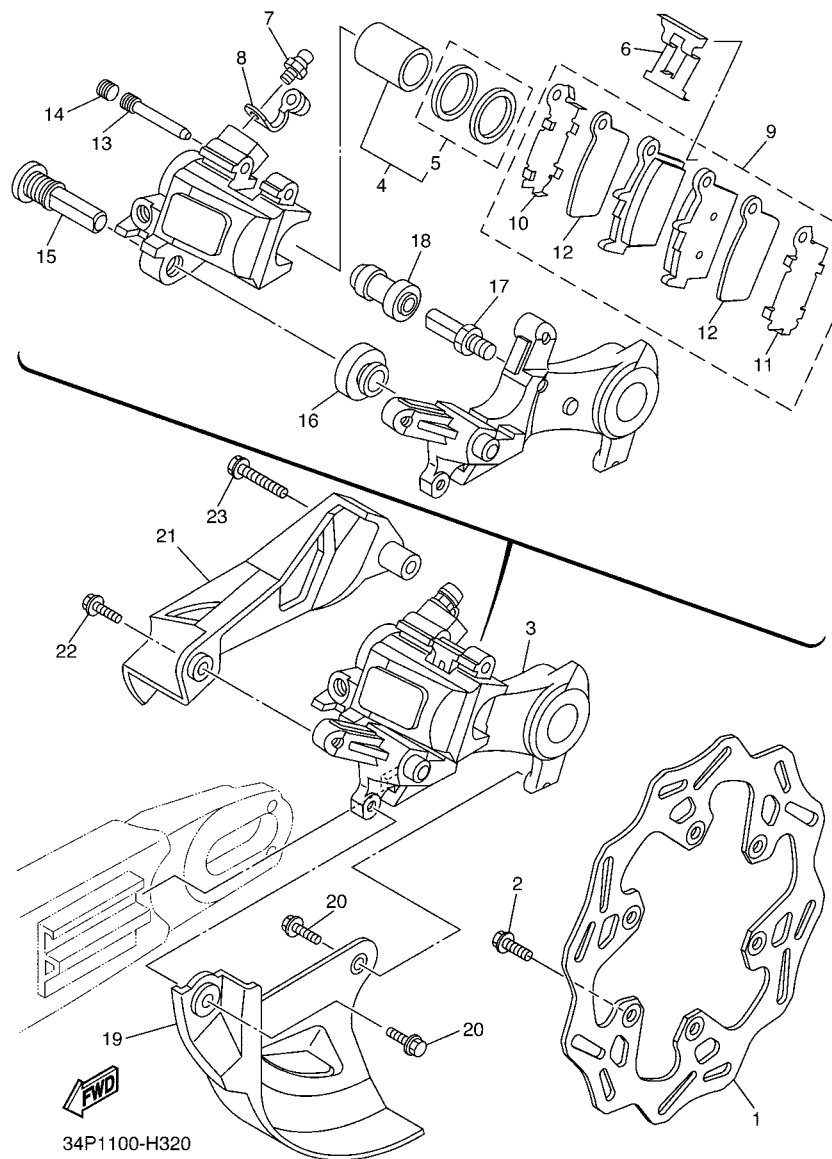
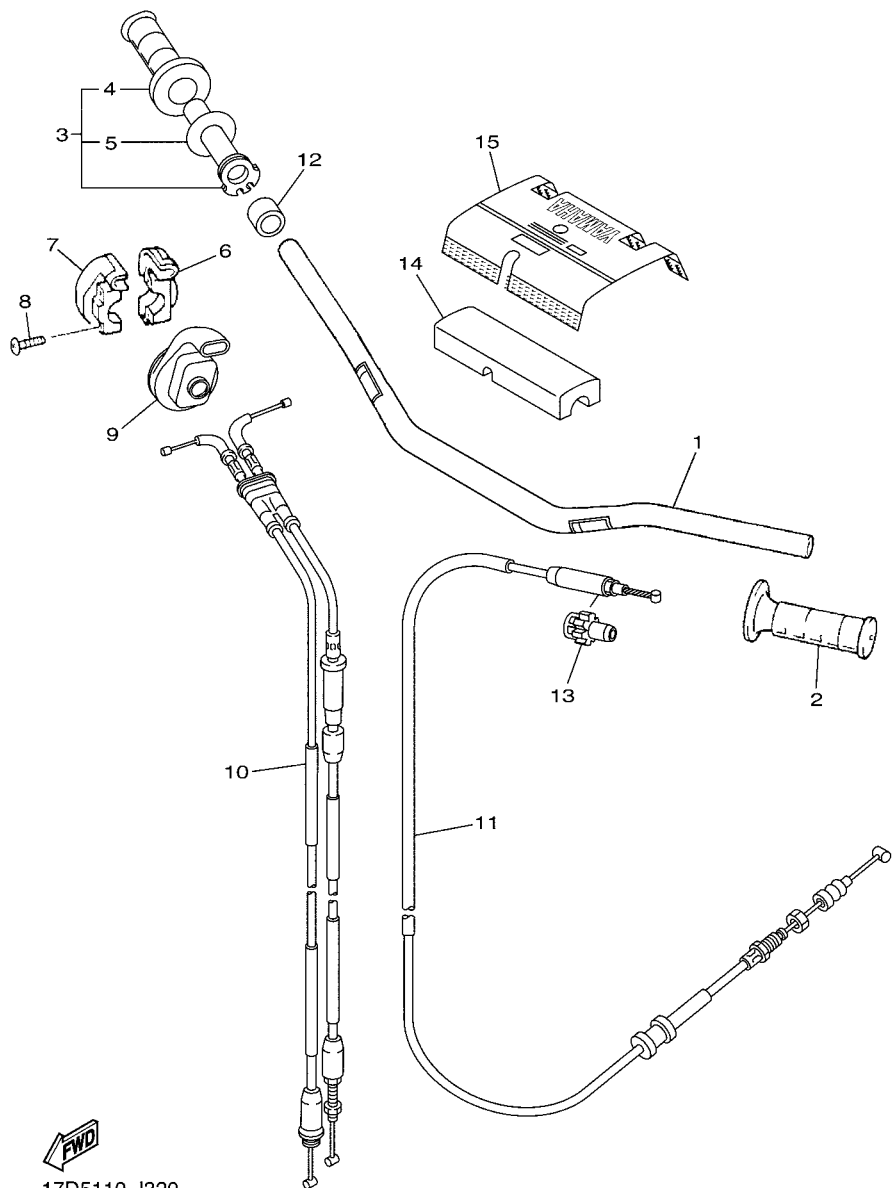

FIG. 31 REAR BRAKE CALIPER

REF. NO.	PART NO.	DESCRIPTION	17D9	17DA	17DB	17DC	REMARKS
1	2S2-2582W-70	DISK, REAR BRAKE 2	1	1	1	1	
2	90105-06156	BOLT, FLANGE	6	6	6	6	
3	17D-2580W-01	CALIPER ASSY, REAR 2	1		1	1	
	17D-2580W-11	CALIPER ASSY, REAR 2		1			
4	5UN-W0057-50	.PISTON ASSY, CALIPER	1	1	1	1	
5	5UN-W0047-50	..CALIPER SEAL KIT	1	1	1	1	
6	5DH-25919-50	.SUPPORT, PAD	1	1	1	1	
7	1UY-25824-51	.SCREW, BLEED	1	1	1	1	
8	1UY-25825-51	.CAP	1	1	1	1	
9	1C3-W0046-50	.BRAKE PAD KIT 2	1		1	1	
	1C3-W0046-B0	.BRAKE PAD KIT 2		1			
10	5UN-25828-60	..SHIM, CALIPER	1	1	1	1	
11	5UN-25827-60	..SHIM, CALIPER	1	1	1	1	
12	5UN-22898-60	..INSULATOR, HEAT	2	2	2	2	
13	8CR-25924-00	.PIN, PAD	1	1	1	1	
14	5DH-25916-00	.PLUG	1	1	1	1	
15	5DH-25914-50	.PIN, SLIDE	1	1	1	1	
16	3JD-25917-00	.BOOT, CALIPER	1	1	1	1	
17	5UN-25914-00	.PIN, SLIDE	1	1	1	1	
18	1UY-25937-51	.BOOT 2	1	1	1	1	
19	17D-25718-50	PROTECTOR, DISK BRAKE	1	1	1	1	
20	90105-06110	BOLT, FLANGE	2	2	2	2	
21	17D-27491-50	PROTECTOR	1	1	1	1	
22	90105-06107	BOLT, FLANGE	1	1	1	1	
23	90105-06111	BOLT, FLANGE	1	1	1	1	

**FIG. 32 STEERING HANDLE & CABLE**

REF. NO.	PART NO.	DESCRIPTION	17D9	17DA	17DB	17DC	REMARKS
1	5XC-26111-L2	HANDLEBAR	1	1	1	1	
2	4GY-26241-00	GRIP	1	1	1	1	
3	17D-26240-90	GRIP ASSY	1	1	1	1	
4	4GY-26242-00	.GRIP (RIGHT)	1	1	1	1	
5	3Y1-26249-00	.RING, LEAF	1	1	1	1	
6	5BE-26281-01	CAP, GRIP UPPER	1	1	1	1	
7	5BE-26282-00	CAP, GRIP UNDER	1	1	1	1	
8	98507-05020	SCREW, PAN HEAD	2	2	2	2	
9	5SF-26287-10	COVER, CAP GRIP	1	1	1	1	
10	17D-26302-90	THROTTLE CABLE ASSY	1	1	1	1	
11	17D-26335-50	CABLE, CLUTCH	1	1	1	1	
12	90387-225N2	COLLAR	1	1	1	1	
13	34P-26342-00	BOOT, CABLE	1	1	1	1	
14	17D-26124-00	PROTECTOR, HANDLEBAR	1	1	1	1	
15	5XC-26143-L0	COVER, HAND UPPER 1	1	1	1	1	UR FOR DPBSE
	5XC-26143-M0	COVER, HAND UPPER 1	1	1	1	1	UR FOR PWS1



17D5110-J320

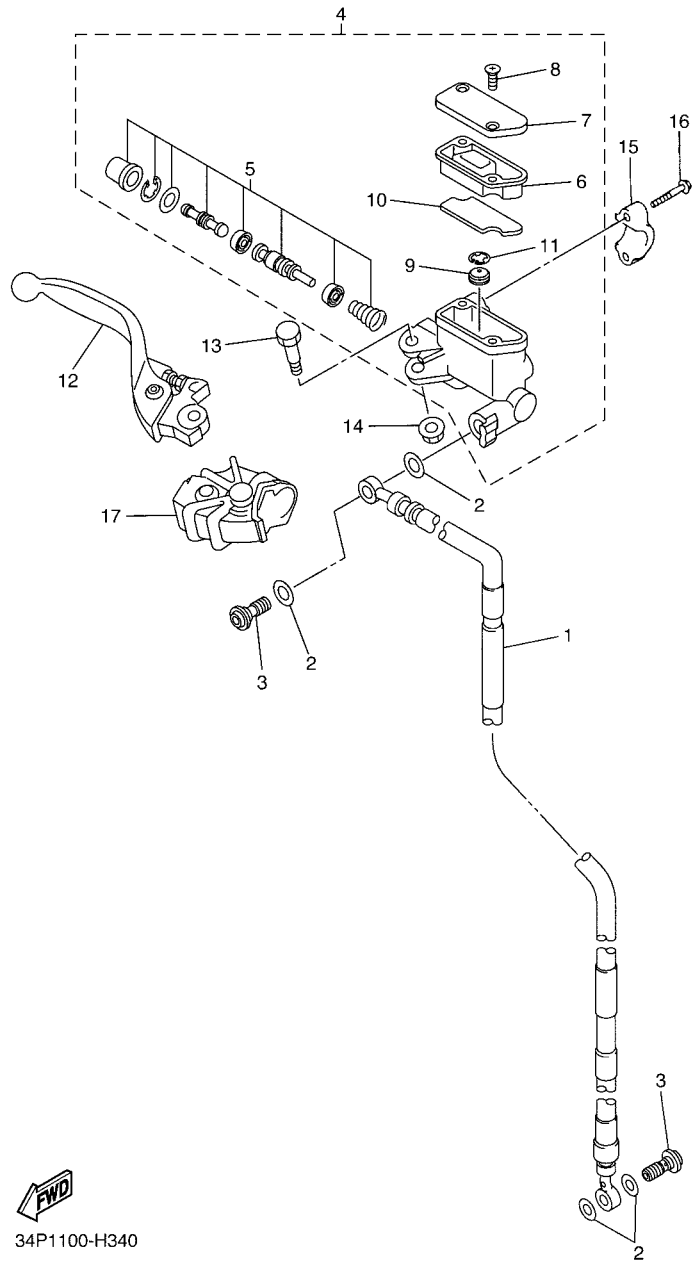

**FWD**  
34P1100-H340

**FIG. 33 FRONT MASTER CYLINDER**

REF. NO.	PART NO.	DESCRIPTION	17D9	17DA	17DB	17DC	REMARKS
1	17D-25872-50	HOSE, BRAKE 1	1	1	1	1	
2	90430-10005	GASKET	4	4	4	4	
3	90401-10172	BOLT, UNION	2	2	2	2	
4	5XC-W2587-00	MASTER CYLINDER SUB ASSY	1	1	1	1	
5	5XC-W0041-00	.CYLINDER KIT, MASTER	1	1	1	1	
6	5XC-25854-G0	.DIAPHRAGM, RESERVOIR	1	1	1	1	
7	5XC-25852-G0	.CAP, RESERVOIR	1	1	1	1	
8	98706-04012	.SCREW, FLAT HEAD	2	2	2	2	
9	5CG-25715-00	.SEPARATOR ASSY	1	1	1	1	
10	5XC-25853-G0	.FLOAT, RESERVOIR	1	1	1	1	
11	5CG-2585G-00	.CIRCLIP	1	1	1	1	
12	5XC-83922-L0	LEVER 2	1	1	1	1	
13	5MV-2589F-00	BOLT, LEVER	1	1	1	1	
14	95701-06500	NUT, WITH WASHER	1	1	1	1	
15	5MV-25867-00	BRACKET, MASTER CYLINDER	1	1	1	1	
16	5MV-25833-00	BOLT, FITTING	2	2	2	2	
17	5XC-26372-G0	COVER, HANDLE LEVER 1	1	1	1	1	

FIG. 34 STAND & FOOTREST

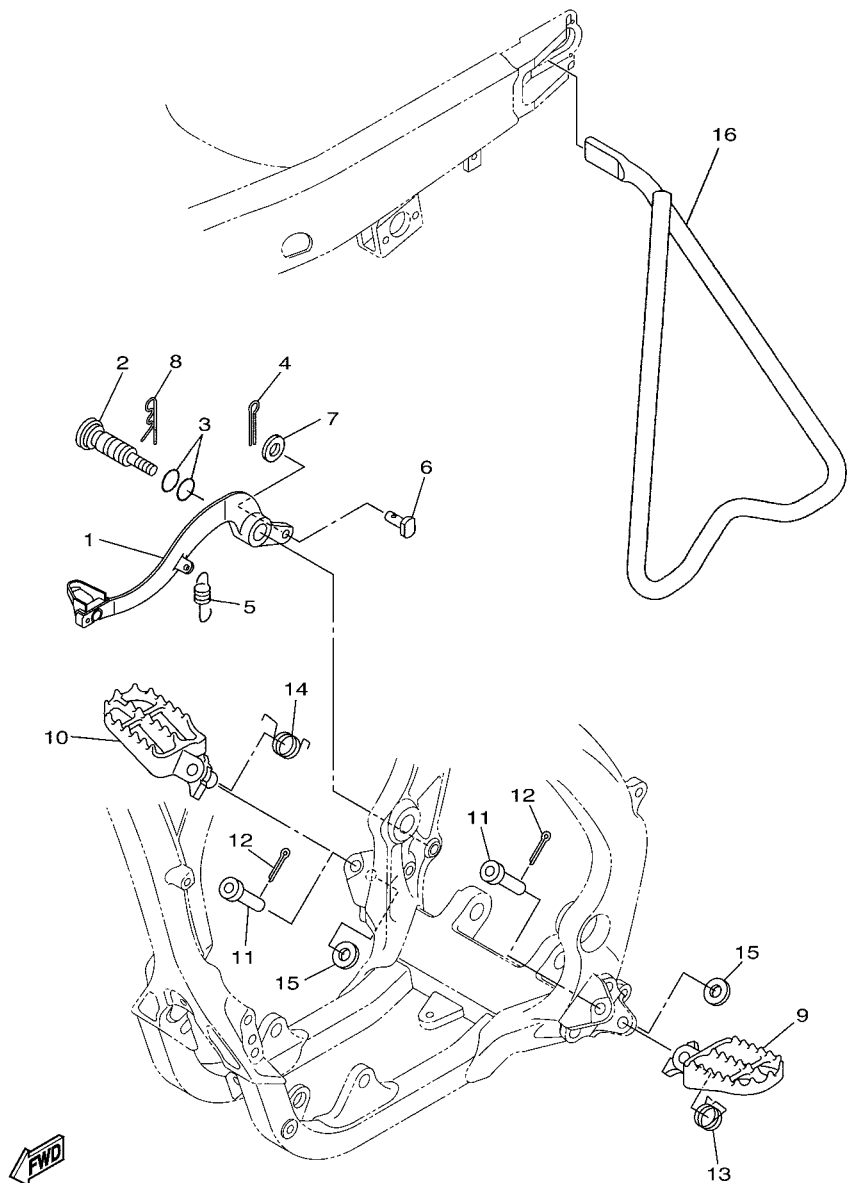

17D5110-J340

REF. NO.	PART NO.	DESCRIPTION	17D9	17DA	17DB	17DC	REMARKS
1	17D-27200-51	PEDAL, BRAKE	1	1	1	1	
2	17D-27217-00	BOLT	1	1	1	1	
3	93210-11073	O-RING	2	2	2	2	
4	91402-20012	PIN, COTTER	1	1	1	1	
5	90506-16007	SPRING, TENSION	1	1	1	1	
6	90240-08120	PIN, CLEVIS	1	1	1	1	
7	90201-08044	WASHER, PLATE	1	1	1	1	
8	90468-16001	CLIP	1	1	1	1	
9	17D-27411-00	FOOTREST 1	1	1	1	1	
10	17D-27421-00	FOOTREST 2	1	1	1	1	
11	90240-10004	PIN, CLEVIS	2	2	2	2	
12	91402-25015	PIN, COTTER	2	2	2	2	
13	90508-28015	SPRING, TORSION	1	1	1	1	
14	90508-28018	SPRING, TORSION	1	1	1	1	
15	90201-10032	WASHER, PLATE	2	2	2	2	
16	34P-27311-00	STAND, SIDE	1	1	1	1	







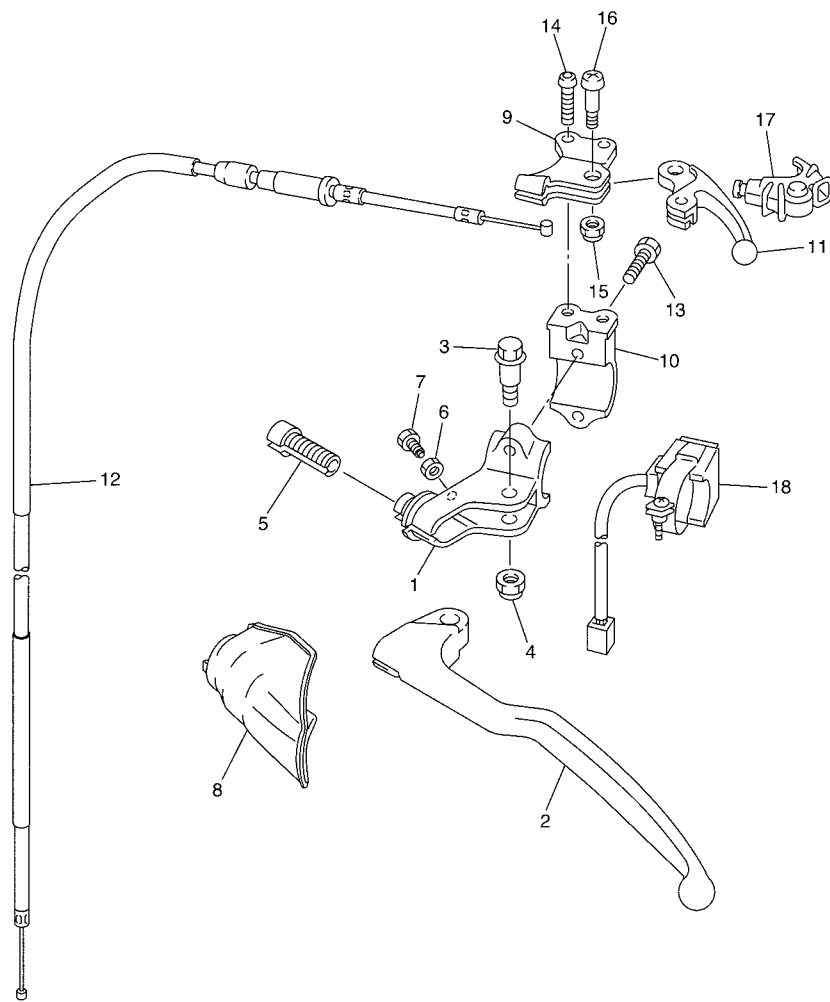

34P1100-H380

FIG. 37 HANDLE SWITCH & LEVER

REF. NO.	PART NO.	DESCRIPTION	17D9	17DA	17DB	17DC	REMARKS
1	17D-82911-00	HOLDER, LEVER 1	1	1	1	1	
2	17D-83912-00	LEVER 1	1	1	1	1	
3	90109-06034	BOLT	1	1	1	1	
4	5LP-84126-10	NUT, LENS FITTING	1	1	1	1	
5	17D-26337-00	BOLT, ADJUSTING	1	1	1	1	
6	95302-05600	NUT	1	1	1	1	
7	90101-05005	BOLT	1	1	1	1	
8	34P-26372-00	COVER, HANDLE LEVER 1	1	1	1	1	
9	5XD-82946-00	HOLDER, STARTER LEVER	1	1	1	1	
10	17D-82913-00	HOLDER, LEVER LOWER 1	1	1	1	1	
11	5TA-83941-00	LEVER, STARTER	1	1	1	1	
12	17D-26334-50	CABLE, STARTER 2	1	1	1	1	
13	95022-06020	BOLT, FLANGE	2	2	2	2	
14	92012-05012	BOLT, BUTTON HEAD	2	2	2	2	
15	95602-05100	NUT, U	1	1	1	1	
16	90149-05162	SCREW	1	1	1	1	
17	5TA-26339-00	BOOT	1	1	1	1	
18	17D-83976-10	SWITCH, HANDLE 1	1	1	1	1	

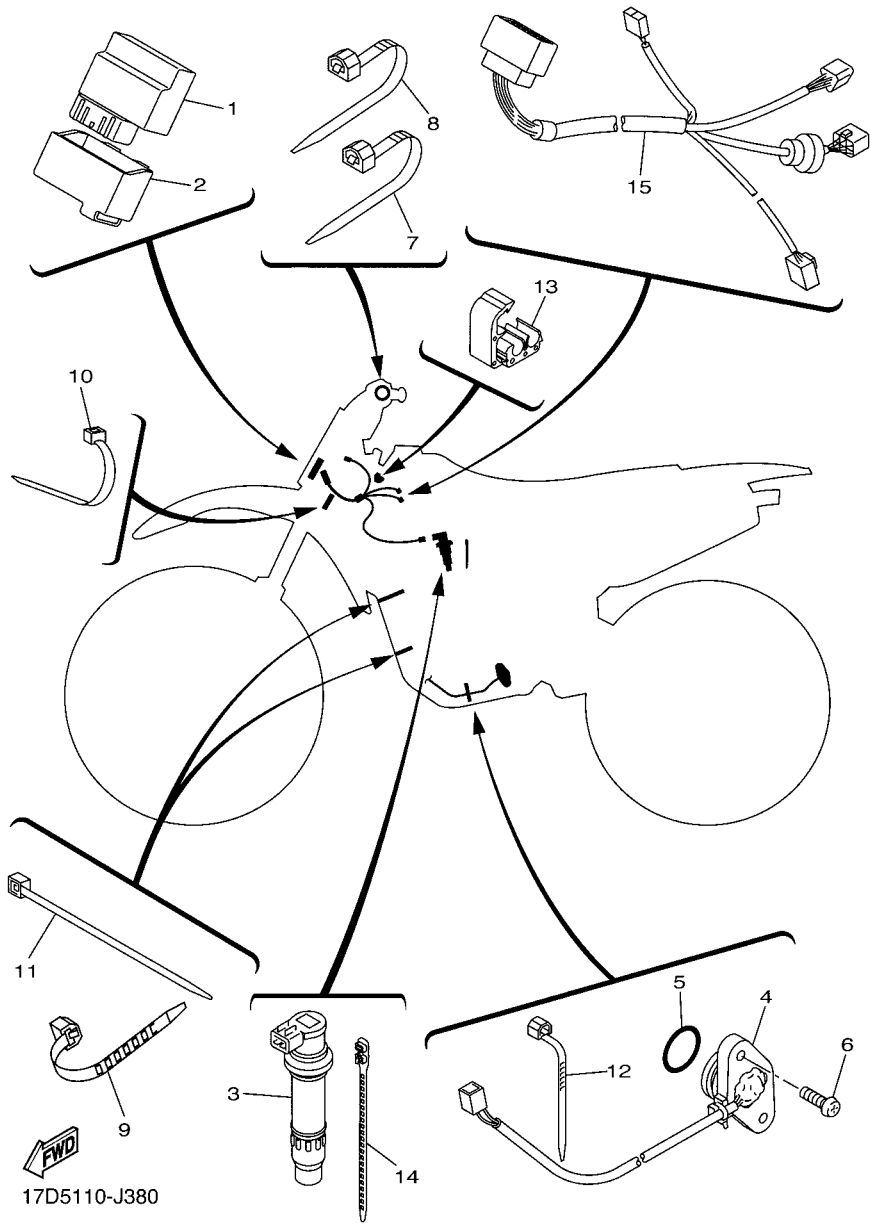

FIG. 38 ELECTRICAL 1

REF. NO.	PART NO.	DESCRIPTION	17D9	17DA	17DB	17DC	REMARKS
1	17D-85540-90	C.D.I. UNIT ASSY	1	1	1	1	
2	17D-85546-50	BAND	1	1	1	1	
3	5UL-82310-20	IGNITION COIL ASSY	1	1	1	1	
4	17D-82540-00	NEUTRAL SWITCH ASSY	1	1	1	1	
5	93210-21001	O-RING	1	1	1	1	
6	90154-05022	SCREW, BINDING	2	2	2	2	
7	90464-13077	CLAMP	1	1	1	1	
8	90464-13073	CLAMP	1	1	1	1	
9	90464-15195	CLAMP	1	1	1	1	
10	90464-16019	CLAMP	1	1	1	1	
11	90464-13077	CLAMP	1	1	1	1	
12	5Y9-12491-00	CLAMP 1	2	2	2	2	
13	90464-06004	CLAMP	1	1	1	1	
14	90464-45001	CLAMP	1	1	1	1	
15	17D-82509-50	WIRE, SUB LEAD	1	1	1	1	

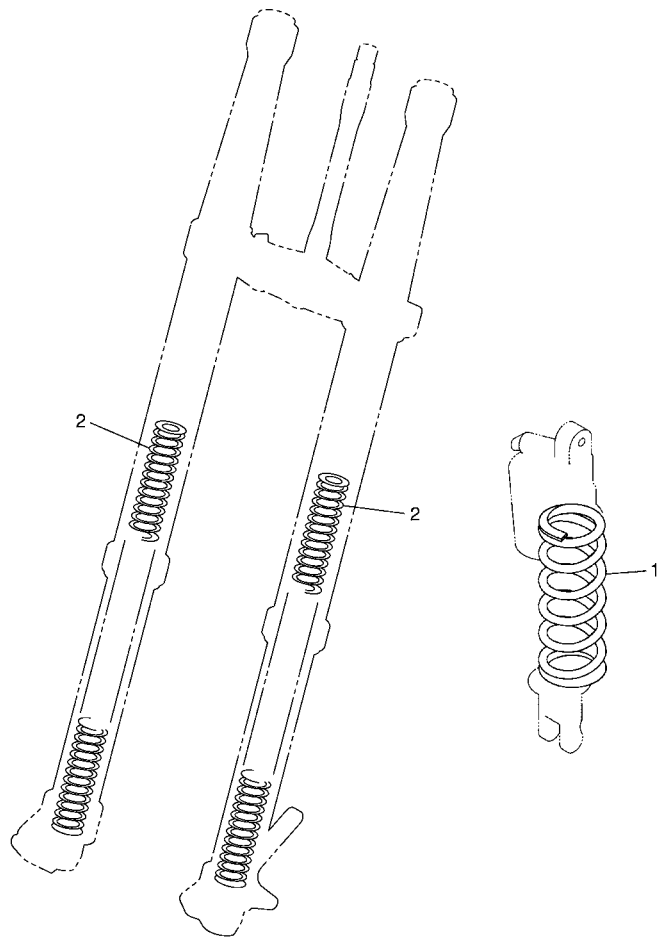

FIG. 39 ALTERNATE FOR CHASSIS

REF. NO.	PART NO.	DESCRIPTION	17D9	17DA	17DB	17DC	REMARKS
1	5UN-22212-00	SPRING (K=42N/MM)	1	1	1	1	AP
	5UN-22212-10	SPRING (K=44N/MM)	1	1	1	1	AP
	5UN-22212-20	SPRING (K=46N/MM)	1	1	1	1	AP
	5UN-22212-30	SPRING (K=48N/MM)	1	1	1	1	AP
	5UN-22212-40	SPRING (K=50N/MM)	1	1	1	1	AP
	5UN-22212-50	SPRING (K=52N/MM)	1	1	1	1	AP
	5UN-22212-60	SPRING (K=54N/MM)	1	1	1	1	AP
	5UN-22212-70	SPRING (K=56N/MM)	1	1	1	1	AP
2	1C3-23141-A1	SPRING, FRONT FORK(K=3.9N/MM)	2	2	2	2	AP
	1C3-23141-B1	SPRING, FRONT FORK(K=4.0N/MM)	2	2	2	2	AP
	1C3-23141-C1	SPRING, FRONT FORK(K=4.1N/MM)	2	2	2	2	AP
	1C3-23141-D1	SPRING, FRONT FORK(K=4.2N/MM)	2	2	2	2	AP
	1C3-23141-E1	SPRING, FRONT FORK(K=4.3N/MM)	2	2	2	2	AP
	1C3-23141-F1	SPRING, FRONT FORK(K=4.4N/MM)	2	2	2	2	AP
	1C3-23141-G1	SPRING, FRONT FORK(K=4.5N/MM)	2	2	2	2	AP
	1C3-23141-H1	SPRING, FRONT FORK(K=4.6N/MM)	2	2	2	2	AP
	1C3-23141-J1	SPRING, FRONT FORK(K=4.7N/MM)	2	2	2	2	AP

NUMERICAL INDEX

PART NO.	REF. NO.	PART NO.	REF. NO.	PART NO.	REF. NO.	PART NO.	REF. NO.	PART NO.	REF. NO.	PART NO.	REF. NO.
17D-11102-11	1 - 1	1HX-12168-R1	3 - 14	5XC-13412-00	7 - 15	5JG-14522-00	10 - 7	5JG-14940-18	10 - 31	5NL-15388-00	12 - 14
5XC-11133-10	1 - 2	1HX-12168-U1	3 - 14	17D-13416-00	21 - 28	5JG-14531-00	10 - 60	5JG-14940-76	10 - 31	17D-15411-50	13 - 1
5NL-11134-10	1 - 3	1HX-12168-W1	3 - 14	5D3-13440-01	8 - 1	3TJ-14536-40	10 - 32	5TA-14943-27	10 - 22	5NL-15415-40	13 - 23
5XC-11166-00	1 - 20	1HX-12168-Y1	3 - 14	5BE-13447-30	8 - 2	5JG-14546-01	10 - 10	4MX-14943-42	10 - 18	17D-15421-90	12 - 9
371-11167-01	1 - 19	1HX-12169-11	3 - 14	17D-13464-00	7 - 18	676-14548-00	10 - 25	4MX-14943-43	10 - 18	5XC-15431-01	13 - 13
5NL-11181-00	1 - 14	1HX-12169-31	3 - 14	17D-13465-00	7 - 23	4MX-14561-00	10 - 50	4MX-14943-44	10 - 18	5NL-15441-01	12 - 8
5NL-11191-50	1 - 18	1HX-12169-50	3 - 14	17D-13597-90	9 - 1	6H4-14561-00	10 - 34	4MX-14943-45	10 - 18	5NL-15451-00	13 - 9
5NL-11193-00	1 - 23	1HX-12169-70	3 - 14	17D-14101-90	10 - 1	5NX-14562-00	10 - 48	4MX-14943-46	10 - 18	5NL-15453-00	13 - 28
5UM-1119E-00	1 - 22	1HX-12169-90	3 - 14	17D-14101-A0	10 - 1	3TJ-14564-40	10 - 43	4MX-14943-93	10 - 18	5NL-15462-00	13 - 18
5XC-11311-10	1 - 24	1HX-12169-E0	3 - 14	5NL-14105-00	10 - 23	5JG-14565-00	10 - 59	4MX-14943-94	10 - 18	5NL-15601-30	14 - 1
5NL-11351-00	1 - 25	1HX-12169-G0	3 - 14	4MX-14115-00	10 - 51	5NL-14591-00	10 - 61	4MX-14943-95	10 - 18	17D-15620-50	14 - 19
17D-11400-90	2 - 1	1HX-12169-J0	3 - 14	3TJ-14137-40	9 - 8	688-14592-00	10 - 4	4MX-14943-96	10 - 18	17D-15621-50	14 - 20
17D-11412-90	2 - 2	1HX-12169-L0	3 - 14		10 - 52	17D-14611-90	11 - 1	17D-14947-00	10 - 17	5NL-15641-30	14 - 2
17D-11422-90	2 - 3	1HX-12169-N0	3 - 14	5BE-14146-00	10 - 53	5NL-14613-00	11 - 5	4MX-14948-01	10 - 19	5NL-15651-00	14 - 16
17D-11454-90	2 - 13	1HX-12169-T0	3 - 14	5PA-14146-00	10 - 62	5XC-14628-R0	11 - 2	17D-14948-02	10 - 19	5NL-15664-00	14 - 10
17D-11455-10	2 - 9	17D-12170-10	4 - 1	5TA-14155-00	10 - 40	17D-1466G-50	11 - 7	4MX-14948-02	10 - 19	5SG-15668-00	14 - 12
5NL-11531-00	2 - 12	17D-12180-10	4 - 2	633-14159-00	10 - 27	17D-1469E-00	11 - 11	4MX-14948-03	10 - 19	2S2-15671-00	14 - 5
5NL-11536-10	2 - 8	5TA-12210-20	4 - 10	3TJ-14159-40	10 - 13	17D-1469F-00	11 - 12	4MX-14948-04	10 - 19	214-15686-00	14 - 13
17D-11603-00	2 - 19	4FM-12213-00	4 - 9	5XC-14171-00	10 - 35	2S2-1469F-00	11 - 10	3TJ-1494F-13	10 - 20	5NL-16111-01	15 - 1
17D-11631-90	2 - 18	5EL-12214-00	4 - 11	3TJ-14191-40	10 - 29	17D-1469G-00	11 - 13	4JT-1494F-13	10 - 21	5XC-16150-10	15 - 4
17D-11633-00	2 - 20	5EL-12228-00	4 - 12	5UL-14196-00	10 - 55	5XD-14714-00	11 - 14	3TJ-1494F-14	10 - 20	5XC-16154-00	15 - 5
17D-11651-90	2 - 6	5BE-12241-00	4 - 14	5TA-14197-00	10 - 56	17D-14750-90	11 - 6	3TJ-1494F-15	10 - 20	5XC-16181-00	15 - 12
5XC-11681-01	2 - 4	5NL-12251-30	4 - 5	5NX-14216-00	10 - 49	17D-14750-A0	11 - 6	3TJ-1494F-16	10 - 20	5XC-16321-00	15 - 7
5NL-12111-30	3 - 1	5NL-12252-00	4 - 6	5TA-14227-00	9 - 5	17D-1477A-00	11 - 9	3TJ-1494F-17	10 - 20	5NL-16325-00	15 - 8
5NL-12112-30	3 - 2	17D-1240A-50	6 - 1	5TA-14239-00	9 - 6	5BE-14788-00	11 - 15	4JT-1494F-17	10 - 21	5HD-16351-00	15 - 9
5NL-12113-10	3 - 8	5NL-12422-10	5 - 9	5TA-14261-00	10 - 54	5TA-14916-L1	10 - 12	3TJ-1494F-18	10 - 20	5XC-16356-00	15 - 16
5NL-12114-10	3 - 9	5NL-12439-00	5 - 10	5JG-14264-00	10 - 16	5TA-14916-LM	10 - 12	3TJ-1494F-19	10 - 20	5NL-16357-10	15 - 21
5NL-12116-00	3 - 4	5DH-12451-00	5 - 4	3TJ-14267-40	10 - 9	5TA-14916-LN	10 - 12	4JT-1494F-21	10 - 21	5NL-16371-31	15 - 6
5VY-12117-00	3 - 10	5XC-12459-00	5 - 1	5JG-14275-00	10 - 15	5TA-14916-LP	10 - 12	4JT-1494F-25	10 - 21	5XC-16381-10	15 - 22
1HX-12118-00	3 - 11	17D-12461-50	6 - 2	5TA-14293-00	9 - 4	5TA-14916-LR	10 - 12	4JT-1494F-28	10 - 21	4JT-16384-00	15 - 25
1WG-12118-00	3 - 13	5SL-12462-00	6 - 3	3TJ-14293-40	10 - 30	5TA-14916-LS	10 - 12	4JT-1494F-30	10 - 21	5NL-17121-00	16 - 9
4SV-12119-00	3 - 7	5XC-12481-G0	6 - 6	5XD-14325-00	10 - 63	5TA-14916-LT	10 - 12	4JT-1494F-32	10 - 21	17D-17131-10	16 - 6
4TV-12119-00	3 - 6	5Y9-12491-00	38 - 12	5TA-14335-00	10 - 37	5TA-14916-LU	10 - 12	5JG-14951-00	10 - 6	17D-17141-10	16 - 7
5NL-12121-10	3 - 3	5NL-12564-00	13 - 21	5JG-14346-00	10 - 58	5TA-14916-P1	10 - 12	5JG-14959-00	10 - 2	17D-17151-10	16 - 3
3GM-12126-00	3 - 5	17D-12576-50	6 - 9	5TA-14371-00	10 - 36		10 - 12	5JG-14984-00	10 - 28	5NL-17211-10	16 - 21
5VY-12127-00	3 - 12	17D-12577-50	6 - 10	2S2-14374-00	10 - 39	5TA-14916-PM	10 - 12	17D-14985-00	10 - 24	5NL-17221-00	16 - 13
3FV-12153-10	3 - 16	17D-12578-50	6 - 11	5JG-14379-00	10 - 42	5TA-14916-PN	10 - 12	5TA-14987-00	9 - 7	17D-17231-10	16 - 17
3LN-12153-10	3 - 15	17D-12579-50	6 - 12	2S2-14388-00	10 - 8	5TA-14916-PP	10 - 12	5TJ-14987-00	10 - 57	17D-17241-10	16 - 16
1HX-12168-00	3 - 14	17D-12581-50	6 - 14	4MX-14392-00	10 - 26	5TA-14916-PR	10 - 12	5TA-14991-00	10 - 38	17D-17251-11	16 - 20
1HX-12168-20	3 - 14	17D-12588-50	6 - 13	17D-14401-00	9 - 11		10 - 12	4FN-14997-00	10 - 11	5NL-17402-01	16 - 12
1HX-12168-40	3 - 14	583-13113-00	8 - 20	5NY-14442-00	9 - 15	5TA-14916-PS	10 - 12	5TA-14997-00	10 - 41	5XC-17411-00	16 - 2
1HX-12168-60	3 - 14	5NL-13161-21	8 - 8	4XM-14451-00	9 - 17	5TA-14916-PT	10 - 12	5XC-15100-38-YX	12 - 1	5NL-17466-00	12 - 11
1HX-12168-80	3 - 14	5NL-13171-10	8 - 13	17D-14452-00	9 - 16	5TA-14916-PU	10 - 12	3Y1-15361-00	13 - 8	5NL-17471-10	16 - 29
1HX-12168-A0	3 - 14	5SG-13300-01	7 - 1	17D-14453-50	9 - 12	5XC-14922-00	10 - 44	3Y1-15363-10	13 - 6	5UL-18101-20	18 - 10
1HX-12168-F0	3 - 14	5NL-13320-00	7 - 3	5NY-14455-20	9 - 14	3TJ-14933-40	10 - 33	5XC-15373-00	13 - 17	5XC-18110-10	18 - 15
1HX-12168-H1	3 - 14	5NL-13341-00	7 - 11	17D-14458-00	9 - 20	5TA-14934-00	10 - 46	17D-15378-00	13 - 30	5LP-18122-01	18 - 5
1HX-12168-K1	3 - 14	5BE-13342-00	7 - 10	5NY-14459-00	9 - 13	5JG-14940-16	10 - 31	4JT-15381-01	12 - 16	3XK-18140-00	17 - 8
1HX-12168-M1	3 - 14	5NL-13411-00	7 - 16	5JG-14521-00	10 - 14	5JG-14940-17	10 - 31	5BE-15383-01	12 - 12	5BE-18172-00	18 - 3

NUMERICAL INDEX

PART NO.	REF. NO.	PART NO.	REF. NO.	PART NO.	REF. NO.	PART NO.	REF. NO.	PART NO.	REF. NO.	PART NO.	REF. NO.
3XJ-18173-10	18 - 2	17D-21740-10	21 - 18	5UN-22212-L0	23 - 17	5XC-23146-10	25 - 31	3FB-2415E-12	20 - 6	17D-25452-50	30 - 6
3XJ-18178-00	18 - 9	17D-21740-D0	21 - 18	1C3-22213-L0	23 - 4	1AE-23147-00	25 - 19	3FB-2415E-C1	20 - 5	5CG-25715-00	33 - 9
3XJ-18182-00	18 - 8	17D-21749-00	21 - 14	17D-22214-00	23 - 18		25 - 43	4SR-2416E-00	20 - 7		35 - 9
3XJ-18184-00	18 - 7		21 - 20	5MV-22224-00	23 - 9	1C3-23147-L0	25 - 12	5SF-24173-00	26 - 12	17D-25718-50	31 - 19
2S2-18185-00	18 - 1	5BE-21749-00	21 - 3	4JX-22226-00	23 - 6		25 - 36	4KB-24181-00	6 - 19	5XC-2580T-G0	29 - 3
5NL-18501-00	17 - 5		21 - 7	3SP-22234-00	23 - 3	17D-23153-00	25 - 3	17D-24181-50	26 - 17	17D-2580W-01	31 - 3
5NL-18502-00	17 - 6		21 - 15	5NY-22241-00	23 - 22		25 - 27	17D-24182-50	26 - 27	17D-2580W-11	31 - 3
5NL-18503-00	17 - 7		21 - 21	5XE-22242-00	23 - 19	5XE-23153-L0	25 - 9	3JD-24186-00	26 - 10	5XC-2581T-G0	29 - 1
5NL-18541-00	17 - 1	17D-2174G-30	21 - 16	1C3-22253-50	23 - 10		25 - 33	3XJ-24380-00	26 - 4	1UY-25824-51	31 - 7
4UN-18542-00	17 - 4	17D-2174G-40	21 - 16	1C3-22253-L1	23 - 15	2HH-23158-L0	25 - 23	4DP-24500-10	26 - 18	1UY-25825-51	31 - 8
5DH-18562-00	12 - 18	17D-2174H-30	21 - 22	4AA-22259-40	23 - 8		25 - 47	4X8-24512-10	26 - 21	5UN-25827-60	31 - 11
17D-21101-90	19 - 1	17D-2174H-40	21 - 22	4AA-22259-50	23 - 8	17D-2315H-50	25 - 52	3AC-24523-00	26 - 22	5UN-25828-60	31 - 10
17D-21131-00	19 - 10	17D-2174L-10	21 - 9	4AA-22259-70	23 - 8	17D-2315J-50	25 - 51	3AJ-24534-10	26 - 19	2S2-2582W-70	31 - 1
17D-21163-50	19 - 33	17D-21751-00	21 - 27	4EW-22474-00	23 - 12	17D-2316A-20	25 - 14	5NY-24610-10	26 - 2	5MV-25833-00	33 - 16
17D-21164-50	19 - 42	5FK-2175C-00	21 - 17	3JE-22475-00	23 - 11		25 - 38	17D-2470F-00	27 - 2	17D-2583V-00	35 - 1
17D-2117F-50	19 - 45		21 - 23	5NY-22475-00	23 - 16	17D-23170-20	25 - 11	17D-2470F-10	27 - 2	5XC-25849-G0	29 - 15
5PA-2118K-00	20 - 18	17D-22110-90	22 - 1	5UN-22898-60	31 - 12		25 - 35	5UN-24710-90	27 - 1	5UN-25852-50	35 - 5
5PA-2118K-10	20 - 19	5XC-22121-91	22 - 28	1C3-22969-90	22 - 9	5XE-23171-L0	25 - 5	17D-24710-A0	27 - 1	5XC-25852-G0	33 - 7
5PA-2118K-20	20 - 18	34P-22122-00	22 - 29	17D-23102-20	25 - 1		25 - 29	5NY-25104-00	28 - 7	5XC-25853-G0	33 - 10
17D-21190-10	19 - 7	2S2-22128-70	22 - 11	17D-23103-20	25 - 25	5DH-23183-00	23 - 7	5NY-25111-00	28 - 1	5UN-25854-00	35 - 7
17D-21244-10	19 - 32	17D-22141-50	22 - 15	17D-23110-10	25 - 28	509-23184-L0	23 - 5	5NY-25117-00	28 - 3	5XC-25854-G0	33 - 6
17D-21274-50	19 - 38	34P-22151-01	22 - 8	5XC-23111-00	25 - 22	1C3-23188-L0	25 - 15	5XC-25181-G0	28 - 14	5UN-2585B-00	35 - 6
17D-21335-50	19 - 5	5UN-22176-00	23 - 13		25 - 46		25 - 39	5XC-25183-G0	28 - 15	5CG-2585G-00	33 - 11
17D-21417-51	19 - 35	30X-22178-00	19 - 11	276-23114-00	25 - 24	1C3-23188-N0	25 - 16	5XC-25186-G0	28 - 16		35 - 10
17D-21425-90	19 - 26	3JD-22178-20	19 - 16		25 - 48		25 - 40	56A-25195-00	28 - 9	5MV-25867-00	33 - 15
17D-21426-90	19 - 27	17D-2217A-00	22 - 18	17D-23120-10	25 - 4	1C3-23188-P0	25 - 17	5NY-25196-00	28 - 8	17D-25872-50	33 - 1
17D-21447-00	19 - 2	17D-2217F-50	22 - 24	5XE-23125-L0	25 - 6		25 - 41	34P-25304-00	30 - 10	5XC-25873-L0	35 - 12
17D-21448-00	19 - 3	4V4-22184-00	19 - 12		25 - 30	1C3-23188-R0	25 - 18	17D-2530S-00	30 - 22	1C3-25876-50	35 - 17
5XC-21456-90	19 - 37	5MV-22184-00	23 - 14	33D-23136-00	25 - 2		25 - 42	17D-25311-00	30 - 1	1C3-25886-50	35 - 15
17D-2147E-51	19 - 40	2S2-22199-70	22 - 10		25 - 26	1C3-23190-L0	25 - 20	17D-25317-00	30 - 2	5MV-2589F-00	33 - 13
17D-21511-50	20 - 1	17D-22200-90	23 - 1	1C3-23141-A1	39 - 2		25 - 44	17D-2531B-00	28 - 6	5UN-25914-00	31 - 17
17D-21511-60	20 - 1	17D-22200-A0	23 - 1	1C3-23141-B1	39 - 2	33D-23340-00	25 - 49		30 - 15	5DH-25914-50	31 - 15
17D-21610-00	20 - 8	17D-22200-B0	23 - 1	1C3-23141-C1	39 - 2	17D-23389-50	24 - 16	4XM-25364-00	30 - 20	3SP-25914-51	29 - 12
17D-21610-10	20 - 8	17D-22200-D0	23 - 1	1C3-23141-D1	39 - 2	17D-2339E-20	24 - 15	17D-25381-00	30 - 27	5DH-25916-00	29 - 10
5XE-21635-10	20 - 9	17D-22200-E0	23 - 1	1C3-23141-E1	39 - 2	17D-23416-50	24 - 3	17D-25388-00	30 - 23		31 - 14
17D-21642-00	20 - 15	17D-22200-F0	23 - 1	1C3-23141-F1	39 - 2	33D-23435-00	24 - 6	33D-25389-00	30 - 24	3JD-25917-00	29 - 13
3RV-21668-A0	22 - 32	17D-22201-50	23 - 2	1C3-23141-G1	39 - 2	18P-23441-00	24 - 8	4XM-25394-00	30 - 19		31 - 16
3RV-21668-B0	22 - 33	17D-22201-60	23 - 2	1C3-23141-H1	39 - 2	17D-23442-10	24 - 9	5SF-25394-00	28 - 13	5DH-25919-00	29 - 6
17D-21710-00	21 - 1	17D-22201-70	23 - 2	1C3-23141-J1	39 - 2	17D-23466-00	25 - 54	5ET-25395-00	30 - 13	5DH-25919-50	31 - 6
5XC-21719-90	21 - 8	5UN-22212-00	39 - 1	2S2-23141-M1	25 - 21	17D-23467-00	25 - 55	34P-25396-00	30 - 11	8CR-25924-00	31 - 13
17D-21720-00	21 - 5	5UN-22212-10	39 - 1		25 - 45	17D-23485-50	24 - 13	34P-25397-00	30 - 12	3SP-25926-51	29 - 11
17D-2172A-00	21 - 25	5UN-22212-20	39 - 1	17D-23142-00	25 - 13	17D-23591-50	19 - 43	17D-25447-50	30 - 6	5DH-25933-00	29 - 9
17D-2172A-10	21 - 26	5UN-22212-30	39 - 1		25 - 37	17D-24110-50	26 - 1	17D-25448-50	30 - 6	1UY-25937-51	29 - 14
17D-21730-10	21 - 12	5UN-22212-40	39 - 1	5XE-23144-L0	25 - 10	3C5-2411B-20	20 - 17	17D-25449-50	30 - 6		31 - 18
17D-21730-D0	21 - 12	5UN-22212-50	39 - 1		25 - 34	17D-2412F-00	26 - 15	17D-25450-50	30 - 6	5XC-26111-L2	32 - 1
17D-2173E-20	21 - 4	5UN-22212-60	39 - 1	17D-23145-00	25 - 8	4EW-2412F-00	26 - 13		30 - 6	17D-26124-00	32 - 14
17D-2173E-30	21 - 4	5UN-22212-70	39 - 1		25 - 32	17D-24144-00	26 - 6	17D-25451-50	30 - 6	5XC-26143-L0	32 - 15
17D-2173F-20	21 - 9	5UN-22212-K0	23 - 17	5XC-23146-10	25 - 7	3FB-2415E-02	20 - 5		30 - 6	5XC-26143-M0	32 - 15

NUMERICAL INDEX

PART NO.	REF. NO.	PART NO.	REF. NO.	PART NO.	REF. NO.	PART NO.	REF. NO.	PART NO.	REF. NO.	PART NO.	REF. NO.
17D-26240-90	32 - 3	1C3-W0046-B0	31 - 9	90105-10361	19 - 22	90201-06571	6 - 23	90387-06009	21 - 19	90464-15195	38 - 9
4GY-26241-00	32 - 2	5KM-W0047-10	29 - 5	90105-10373	19 - 28	90201-06630	21 - 34	90387-06065	6 - 21	90464-16019	38 - 10
4GY-26242-00	32 - 4	5UN-W0047-50	31 - 5	90109-06034	37 - 3	90201-08043	19 - 21	90387-06105	24 - 1	90464-45001	38 - 14
3Y1-26249-00	32 - 5	1UY-W0048-50	29 - 7	90109-06193	17 - 10	90201-08044	34 - 7	90387-06150	21 - 36	90465-08029	13 - 29
5BE-26281-01	32 - 6	5XC-W0057-00	29 - 4	90109-06232	25 - 53	90201-08045	19 - 13	90387-06161	21 - 39	90465-10013	12 - 24
5BE-26282-00	32 - 7	5UN-W0057-50	31 - 4	90109-08078	30 - 7	90201-08048	14 - 25	90387-06259	20 - 2	90467-090A2	6 - 5
5SF-26287-10	32 - 9	5XC-W2587-00	33 - 4	90110-05038	9 - 9		30 - 9	90387-064X4	20 - 10	90467-100A1	26 - 24
17D-26302-90	32 - 10	90101-05005	37 - 7	90110-06228	8 - 5	90201-080H1	15 - 18	90387-08041	19 - 14	90467-140A4	1 - 21
17D-26334-50	37 - 12	90101-06041	18 - 4	90110-08051	14 - 26	90201-082A6	21 - 32	90387-08086	21 - 2	90468-16001	34 - 8
17D-26335-50	32 - 11	90101-06044	14 - 14	90111-06116	35 - 11	90201-08410	10 - 45		21 - 6	90480-08608	30 - 21
17D-26337-00	37 - 5	90101-08006	30 - 25	90116-06038	1 - 10	90201-08512	5 - 2	90387-08096	19 - 9	90480-10068	9 - 21
5TA-26339-00	37 - 17	90105-06027	1 - 6	90119-06149	19 - 41		5 - 5	90387-086N4	19 - 18	90480-10289	21 - 35
34P-26342-00	32 - 13	90105-06064	21 - 24	90119-06255	21 - 37	90201-096J9	1 - 17	90387-124F4	18 - 11	90480-14433	21 - 38
34P-26372-00	37 - 8		24 - 14	90119-08095	21 - 11	90201-10032	34 - 15	90387-14009	22 - 27	90480-15012	6 - 20
5XC-26372-G0	33 - 17	90105-06081	12 - 15	90119-08133	11 - 16	90201-10045	19 - 24	90387-16026	22 - 21	90480-17008	26 - 7
17D-27200-51	34 - 1		12 - 19	90122-06005	9 - 19		19 - 31	90387-18004	22 - 7	90501-043E0	8 - 18
17D-27217-00	34 - 2		16 - 30	90149-05162	37 - 16	90201-12166	7 - 13	90387-18007	12 - 22	90501-052G5	18 - 6
5UN-27217-00	35 - 8	90105-06098	13 - 26	90149-06074	12 - 17	90201-127E1	36 - 5	90387-18012	22 - 6	90501-06022	17 - 3
5UN-27218-00	35 - 3	90105-06100	20 - 11	90149-06084	2 - 14	90201-14020	22 - 30	90387-20006	16 - 8	90501-147A5	14 - 21
5UN-27222-00	35 - 4	90105-06103	21 - 10	90149-06108	26 - 26	90201-15701	13 - 15	90387-22001	16 - 24	90501-160A2	14 - 6
34P-27311-00	34 - 16	90105-06104	22 - 12	90149-06121	36 - 3	90201-16018	22 - 17	90387-220N2	32 - 12	90501-230A2	15 - 10
17D-27411-00	34 - 9	90105-06105	22 - 14	90149-10031	19 - 4	90201-162H4	14 - 11	90401-08006	8 - 11	90506-16007	34 - 5
17D-27421-00	34 - 10	90105-06106	20 - 13	90151-06045	14 - 23	90201-167P7	14 - 7	90401-10015	8 - 9	90508-26561	17 - 9
17D-27491-50	31 - 21	90105-06107	26 - 8	90151-06051	29 - 2	90201-177G4	14 - 17	90401-10172	33 - 3	90508-28015	34 - 13
5XC-28116-00	19 - 48		31 - 22	90151-06071	12 - 13	90201-20685	14 - 3		35 - 13	90508-28018	34 - 14
5TA-2814F-00	19 - 47	90105-06110	31 - 20	90154-05022	38 - 6	90201-21014	22 - 23	90430-06014	1 - 9	90508-291A8	18 - 12
5ET-28166-10	19 - 46	90105-06111	6 - 22	90159-06092	15 - 11	90201-22013	15 - 13		5 - 12	90508-30743	14 - 9
5PG-2816R-00	20 - 18		26 - 9	90170-14171	2 - 16	90201-22023	30 - 29	90430-08119	8 - 12	91312-06020	6 - 8
5UL-82310-20	38 - 3		31 - 23	90170-16326	15 - 15	90201-286K9	24 - 5	90430-10005	33 - 2	91312-06025	7 - 6
17D-82509-50	38 - 15	90105-06127	18 - 16	90179-08019	30 - 26	90202-05193	26 - 25		35 - 14		8 - 7
17D-82540-00	38 - 4		20 - 3	90179-10658	19 - 23	90202-08045	10 - 5	90430-10188	8 - 10		9 - 2
17D-82911-00	37 - 1	90105-06156	31 - 2		19 - 30	90209-06096	9 - 18		12 - 7	91312-06045	12 - 3
17D-82913-00	37 - 10	90105-06170	9 - 22	90179-12657	36 - 4	90209-16011	22 - 22	90445-09003	26 - 3	91312-06055	12 - 4
5XD-82946-00	37 - 9		24 - 17	90179-16011	28 - 17	90209-20008	16 - 4	90445-09005	26 - 5	91312-06065	8 - 6
17D-83912-00	37 - 2		25 - 56	90179-18001	15 - 3		16 - 18	90445-11059	26 - 23	91312-06070	12 - 5
5XC-83922-L0	33 - 12	90105-06189	12 - 10		16 - 28	90209-23012	16 - 14	90445-14017	7 - 29	91316-04012	10 - 3
5TA-83941-00	37 - 11	90105-08137	29 - 16	90179-24004	24 - 7	90215-14204	2 - 15	90450-17001	7 - 30	91317-06030	7 - 7
17D-83976-10	37 - 18	90105-08143	19 - 36	90179-28016	24 - 4	90215-16289	15 - 14	90450-22001	6 - 18	91402-20012	34 - 4
5LP-84126-10	37 - 4	90105-08151	21 - 31	90185-08008	30 - 8	90215-20003	15 - 2		7 - 22	91402-25015	34 - 12
17D-85540-90	38 - 1	90105-08154	24 - 12	90185-08009	19 - 20		16 - 27	90450-25001	6 - 15	91808-16023	1 - 4
17D-85546-50	38 - 2		25 - 50	90185-10012	23 - 23	90240-08120	34 - 6	90450-28001	6 - 16		1 - 5
17D-85550-10	36 - 2	90105-08224	11 - 17	90185-14010	22 - 31	90240-10004	34 - 11	90450-32003	6 - 17	91812-16001	13 - 19
17D-85560-51	36 - 1		19 - 8	90185-16002	22 - 16	90267-48084	11 - 8	90450-58006	9 - 3	91A20-05065	6 - 4
17D-85885-00	10 - 47	90105-08226	19 - 25	90185-22011	30 - 28	90280-03006	2 - 11	90450-61002	9 - 10	92012-05008	19 - 6
5XC-W0041-00	33 - 5	90105-08232	19 - 19	90201-05017	11 - 3	90340-12007	1 - 7	90464-06004	38 - 13		19 - 44
5UN-W0042-50	35 - 2	90105-09002	1 - 16	90201-06085	20 - 14	90340-14015	13 - 4	90464-13073	38 - 8	92012-05012	37 - 14
5XC-W0045-00	29 - 8	90105-09004	1 - 15	90201-06104	20 - 12	90340-32006	13 - 2	90464-13077	38 - 7	92012-06010	19 - 34
1C3-W0046-50	31 - 9	90105-10176	19 - 29	90201-06108	20 - 4	90387-06009	21 - 13		38 - 11		19 - 39

NUMERICAL INDEX

PART NO.	REF. NO.	PART NO.	REF. NO.	PART NO.	REF. NO.	PART NO.	REF. NO.	PART NO.	REF. NO.	PART NO.	REF. NO.
92012-06016	21 - 30	93310-63290	2 - 5	95022-06016	7 - 27	99530-10114	12 - 21				
92902-06600	4 - 8	93311-32261	2 - 17	95022-06020	37 - 13	99530-10116	12 - 23				
92902-10200	23 - 21	93315-32166	22 - 19	95022-06025	4 - 13	9Y581-92113	30 - 30				
	24 - 10	93315-32269	22 - 25		5 - 13	9Y582-28113	30 - 30				
93101-14164	13 - 14	93317-11295	15 - 23		7 - 17		30 - 30				
93102-12106	5 - 7	93317-22262	22 - 2		7 - 21						
93102-12224	15 - 24	93332-00068	24 - 2		7 - 24						
	18 - 14	93332-00081	24 - 18		13 - 12						
93102-18278	14 - 15	93340-21008	15 - 17		13 - 24						
93102-26468	28 - 4	93342-22217	22 - 3	95022-06035	1 - 28						
93102-28010	16 - 25	93410-20038	14 - 4		13 - 11						
93102-32337	30 - 4	93410-22039	16 - 5		13 - 20						
93106-22002	22 - 4		16 - 19		13 - 25						
93109-11073	5 - 6	93410-26067	16 - 15	95022-06065	5 - 14						
93109-22019	22 - 26	93440-07182	5 - 3	95022-08040	19 - 15						
93109-25001	22 - 20		15 - 19	95022-10016	12 - 6						
93109-28043	22 - 5	93440-10153	7 - 4	95302-05600	37 - 6						
93210-07003	8 - 14	93440-41178	4 - 3	95602-05100	37 - 15						
93210-07135	8 - 4	93450-17129	2 - 21	95602-10200	23 - 20						
93210-09525	8 - 15	93503-08007	8 - 19		24 - 11						
93210-09754	7 - 28	93507-32009	14 - 22	95612-08620	1 - 11						
93210-10197	7 - 8	93511-32027	15 - 20	95701-06500	33 - 14						
	7 - 19	93603-16219	7 - 2	95702-06500	1 - 26						
	7 - 25	93604-10011	5 - 11		22 - 13						
	12 - 20	93608-33002	18 - 13	95702-08500	1 - 12						
93210-11073	34 - 3	93612-16254	1 - 27	97022-06016	4 - 7						
93210-12010	8 - 16		12 - 2	97702-60016	20 - 16						
93210-14369	13 - 5	9383B-13218	16 - 26	98502-05010	35 - 16						
	21 - 29	94108-21027	28 - 10	98507-03008	26 - 20						
93210-16275	6 - 7	94110-19019	30 - 16	98507-05020	32 - 8						
93210-16716	13 - 22	94209-21229	28 - 11	98702-06020	26 - 16						
93210-17570	14 - 24	94210-19222	30 - 17	98706-04012	33 - 8						
93210-19123	13 - 7	94316-19156	30 - 18	98707-06025	26 - 14						
93210-196A4	16 - 23	94330-21084	28 - 12	98902-06012	21 - 33						
93210-21001	38 - 5	94416-21045	28 - 5	98902-06025	26 - 11						
93210-32172	13 - 3	94418-19036	30 - 14	98980-06008	11 - 4						
93210-47675	8 - 3	94591-53114	4 - 4	99001-08600	7 - 12						
93300-60839	19 - 17	94681-68001	30 - 31	99009-12400	7 - 14						
93306-00105	5 - 8	94682-28001	30 - 31	99009-16400	14 - 8						
93306-00317	16 - 22		30 - 31	99009-17400	14 - 18						
93306-00320	16 - 10	94701-00410	1 - 13	99009-22500	13 - 16						
93306-20335	2 - 10	94701-00411	1 - 13	99009-42700	30 - 5						
93306-20447	16 - 1	94703-00410	1 - 13	99530-08012	7 - 5						
93306-20648	2 - 7	94703-00411	1 - 13	99530-08016	13 - 10						
93306-27209	16 - 11	95022-06010	1 - 8		13 - 27						
93306-90409	28 - 2		15 - 26	99530-10114	7 - 9						
93306-90509	17 - 2	95022-06012	5 - 15		7 - 20						
93306-90510	30 - 3		8 - 17		7 - 26						