



PARTS CATALOGUE

YZ250FT (5XC5) U.S.A.

YZ250F (5XC6) EUROPE

YZ250F (5XC7) JAPAN

YZ250FT (5XC8) CANADA, OCEANIA, SOUTH AFRICA

YZ250FT/YZ250F
PARTS CATALOGUE
©2004 by Yamaha Motor Co., Ltd.
1st edition, August 2004
All rights reserved.
Any reprinting or unauthorized use
without the written permission of
Yamaha Motor Co., Ltd.
is expressly prohibited.
Printed in Japan.

A3

YZ250FT/YZ250F



A4

FOREWORD

This Parts Catalogue is related to the parts for the model(s) on the cover page. When you are ordering replacement parts, please refer to this Parts Catalogue and quote both part numbers and part names correctly.

1. Modifications or additions which have been made after the issue of the Parts Catalogue will be announced in the Parts News.

It is advisable that you make the necessary corrections to the Parts Catalogue according to the Parts News.

2. Abbreviations

The following abbreviations are used in this Parts Catalogue.

“UR” Use specified parts number.

“UN” Use as many as needed.

“AP” Alternate Parts

“LM” Locally Made (Parts need to be ordered locally)

“F#” Frame No. (Applicable machine No.)

“O/S” Over Size

3. The number of components for assembly

- Parts, which are to be supplied in an assembly, are listed with a dot (.) in front of the part name as shown below.
- The numeral appearing to the right of each component part indicates the quantity of parts for each assembly unit.

PART NO.	DESCRIPTION	Q'TY	REMARKS
2F5-83310-60	FRONT FLASHER LIGHT ASSY	2	
115-83311-60	.BULB (6V-18W)	1	

4. Applicable colours of graphics are represented in the “REMARKS” as shown below.

PART NO.	DESCRIPTION	Q'TY	REMARKS
2N4-24110-00-X5	FUEL TANK COMP.	2	MXR
3J1-24240-10	.GRAPHIC, FUEL TANK	1	FOR MXR

5. Note that the illustrations for reference in finding parts numbers are not to be used for assembling. When assembling, please use the applicable service manual.

6. The asterisk (*) before a reference number indicates modified items after the first edition.

FOREWORD

7. Applicable Serial No.

Engine Serial No.

Frame Serial No.

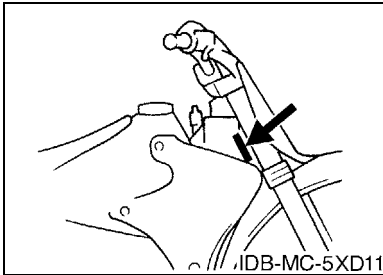
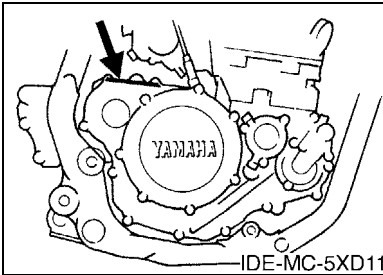

8. Applicable Colour Code (The (*) mark shows Model colour.)

Abbreviation	Colour Name	Colour Code
DPBSE(*)	DEEP PURPLISH BLUE SOLID E	0583

MODEL LABEL

(1) A label called "Model Label" is affixed in the location as indicated in (3) below. When using this parts catalogue, please be sure to cross-reference the "model code – production code No." in the catalogue with the "model code – production code No." indicated on the Model Label affixed onto the product concerned.

(2) "Model Label" Indication

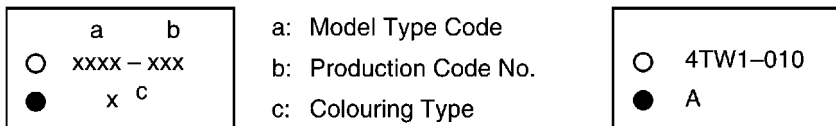

(3) Model Label Affixing Location

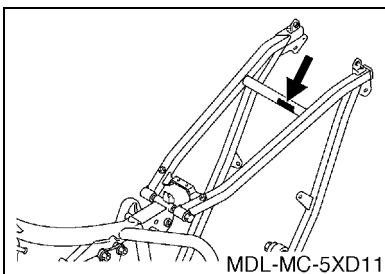

(4) Colouring Information

Model Code	Colouring Type Code	Colour Code	Colour Name	Abbreviation
5XC5	A	0583	DEEP PURPLISH BLUE SOLID E	DPBSE
5XC6	A	0583	DEEP PURPLISH BLUE SOLID E	DPBSE
5XC7	A	0583	DEEP PURPLISH BLUE SOLID E	DPBSE
5XC8	A	0583	DEEP PURPLISH BLUE SOLID E	DPBSE

(5) Model Code – Production Code Number of Model Listed in This Parts Catalogue

Model Code	Production Code No.	Country (destination)	Model Code	Production Code No.	Country (destination)
5XC5	010	U.S.A.			
5XC6	010	EUROPE			
	020	FRANCE			
5XC7	010	JAPAN			
5XC8	010	AUSTRALIA			
		NEW ZEALAND			
		SOUTH AFRICA			
	020	CANADA			

CONTENTS

ENGINE

CYLINDER	B2
CRANKSHAFT & PISTON	B4
VALVE	B5
CAMSHAFT & CHAIN	B7
WATER PUMP	B8
RADIATOR & HOSE	B9
OIL PUMP	B10
OIL CLEANER	B11
INTAKE	B12
CARBURETOR	B13
EXHAUST	C4
CRANKCASE	C5
CRANKCASE COVER 1	C6
STARTER	C8
CLUTCH	C9
TRANSMISSION	C11
SHIFT CAM & FORK	C13
SHIFT SHAFT	C14

CHASSIS

FRAME	C15
FENDER	D3
SIDE COVER	D4
REAR ARM	D5
REAR SUSPENSION	D7
STEERING	D9
FRONT FORK	D10
FUEL TANK	D12
SEAT	D14
FRONT WHEEL	D15
FRONT BRAKE CALIPER	E2
REAR WHEEL	E3
REAR BRAKE CALIPER	E5
STEERING HANDLE & CABLE	E6
FRONT MASTER CYLINDER	E7
STAND & FOOTREST	E8
REAR MASTER CYLINDER	E9
GENERATOR	E10
HANDLE SWITCH & LEVER	E11
ELECTRICAL 1	E12
ALTERNATE FOR CHASSIS	E13

ALTERNATE DECOMPRESSION KIT	E14
-----------------------------------	-----

INDEX

NUMERICAL INDEX	M1
-----------------------	----

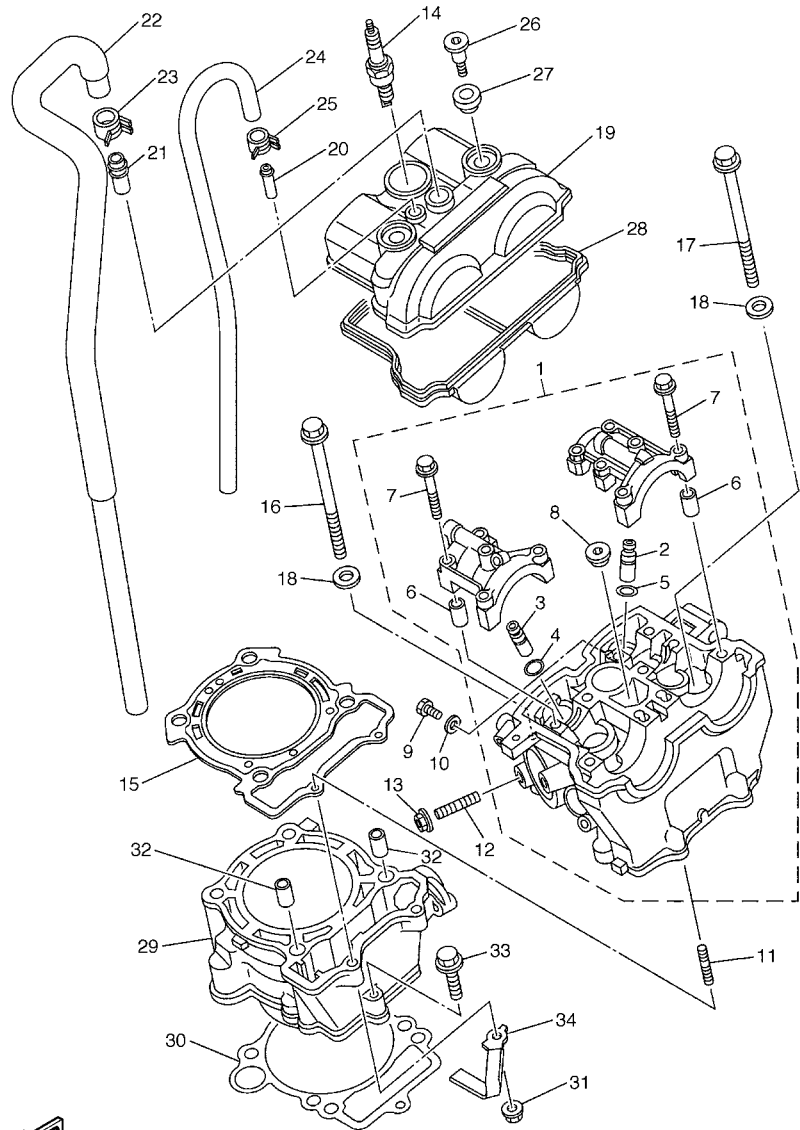

5XC1100-C010

FIG. 1 CYLINDER

REF. NO.	PART NO.	DESCRIPTION	5XC5	5XC6	5XC7	5XC8	REMARKS
1	5XC-11102-00	CYLINDER HEAD ASSY	1	1	1	1	
2	5NL-11133-10	.GUIDE, VALVE 1	3	3	3	3	
3	5NL-11134-10	.GUIDE, VALVE 2	2	2	2	2	
4	93440-10153	.CIRCLIP	2	2	2	2	
5	93440-07149	.CIRCLIP	3	3	3	3	
6	91808-16023	.PIN, DOWEL	4	4	4	4	
7	90105-06027	.BOLT, FLANGE	10	10	10	10	
8	90340-12112	.PLUG, STRAIGHT SCREW	1	1	1	1	
9	95027-06010	BOLT, FLANGE	1	1	1	1	
10	90430-06014	GASKET	1	1	1	1	
11	90116-06541	BOLT, STUD	2	2	2	2	
12	95617-08620	BOLT, STUD	1	1	1	1	
13	95707-08500	NUT, FLANGE	1	1	1	1	
14	94701-00411	PLUG, SPARK (NGK R CR8E)	1	1		1	STD
	94703-00411	PLUG, SPARK (NGK R CR8E)			1		STD
	94701-00410	PLUG, SPARK (NGK R CR9E)	1	1		1	AP
	94703-00410	PLUG, SPARK (NGK R CR9E)			1		AP
15	5NL-11181-00	GASKET, CYLINDER HEAD 1	1	1	1	1	
16	90105-09004	BOLT, FLANGE	2	2	2	2	
17	90105-09002	BOLT, FLANGE	2	2	2	2	
18	90201-096J9	WASHER, PLATE	4	4	4	4	
19	5NL-11191-10	COVER, CYLINDER HEAD 1	1	1	1	1	
20	5BE-11167-00	PIPE, BREATHER 2	1	1	1	1	
21	371-11167-01	PIPE, BREATHER 2	1	1	1	1	
22	5TA-11166-00	PIPE, BREATHER 1	1	1	1	1	
23	90467-14015	CLIP	1	1	1	1	
24	90445-112K0	HOSE (L285)	1	1	1	1	

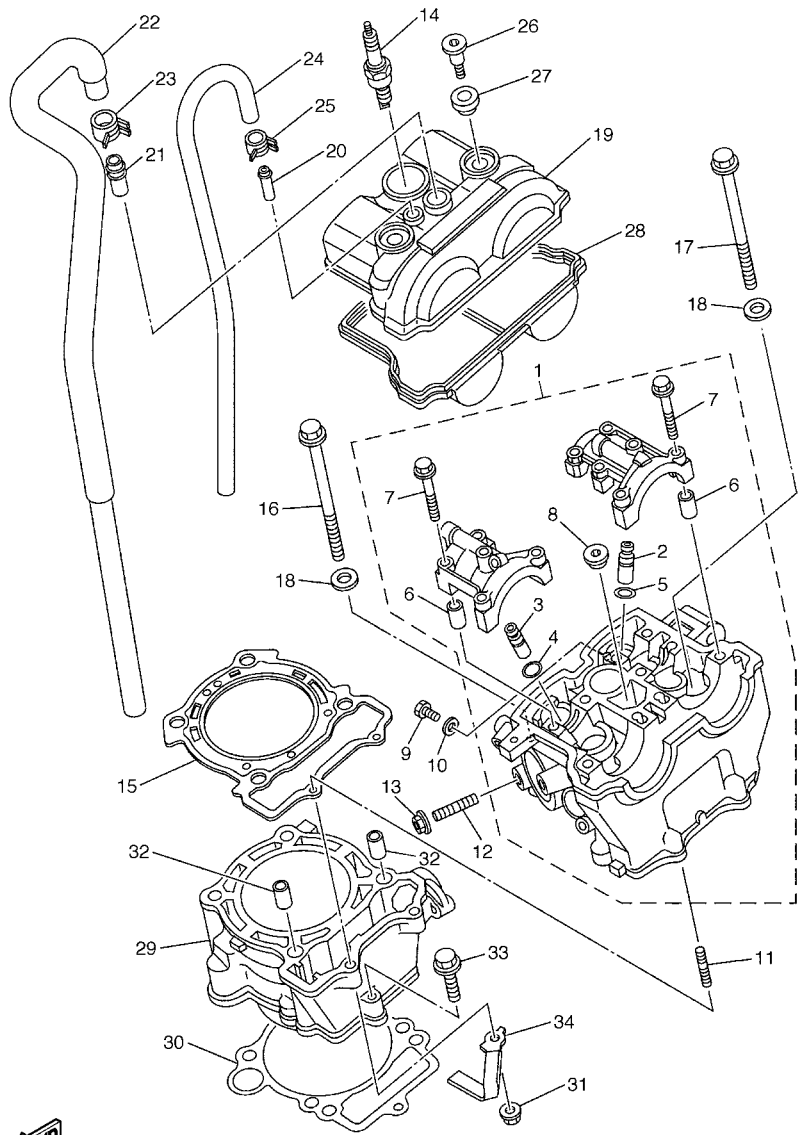

5XC1100-C010

FIG. 1 CYLINDER

REF. NO.	PART NO.	DESCRIPTION	5XC5	5XC6	5XC7	5XC8	REMARKS
25	90467-11106	CLIP	2	2	2	2	
26	90109-066F0	BOLT	2	2	2	2	
27	4KG-1111G-00	RUBBER, MOUNT 1	2	2	2	2	
28	5NL-11193-00	GASKET, HEAD COVER 1	1	1	1	1	
29	5XC-11311-00	CYLINDER 1	1	1	1	1	
30	5NL-11351-00	GASKET, CYLINDER	1	1	1	1	
31	95704-06500	NUT, FLANGE	2	2	2	2	
32	93612-16254	PIN, DOWEL	2	2	2	2	
33	95027-06035	BOLT, FLANGE	1	1	1	1	
34	5UM-11387-00	CLAMP, HOSE 1	1	1	1	1	

FIG. 2 CRANKSHAFT & PISTON

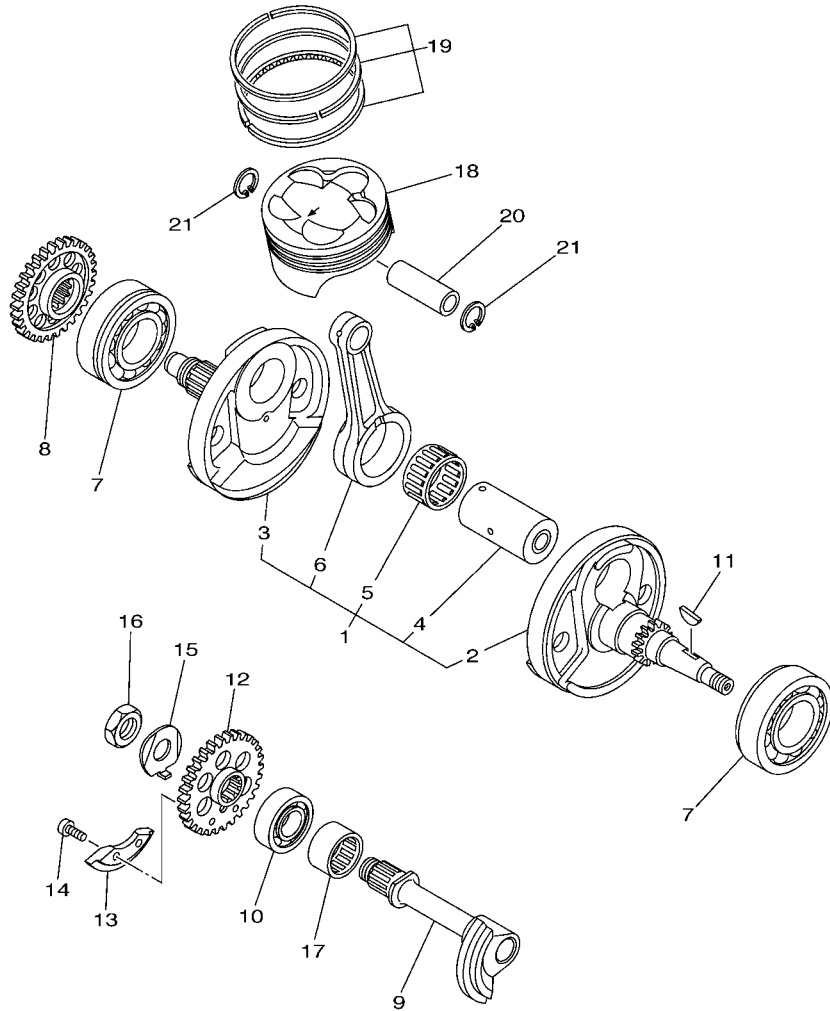

5NL1100-1020

REF. NO.	PART NO.	DESCRIPTION	5XC5	5XC6	5XC7	5XC8	REMARKS
1	5XC-11400-00	CRANKSHAFT ASSY	1	1	1	1	
2	5UL-11412-10	.CRANK 1	1	1	1	1	
3	5UL-11422-00	.CRANK 2	1	1	1	1	
4	5XC-11681-00	.PIN, CRANK 1	1	1	1	1	
5	93310-63238	.BEARING	1	1	1	1	
6	5UL-11651-00	.ROD, CONNECTING	1	1	1	1	
7	93306-20648	BEARING	2	2	2	2	
8	5NL-11536-00	GEAR, DRIVE	1	1	1	1	
9	5NL-11455-00	SHAFT 1	1	1	1	1	
10	93306-20335	BEARING	1	1	1	1	
11	90280-03001	KEY, WOODRUFF	1	1	1	1	
12	5NL-11531-00	GEAR, BALANCE WEIGHT	1	1	1	1	
13	5NL-11454-00	WEIGHT 1	1	1	1	1	
14	90149-06250	SCREW	2	2	2	2	
15	90215-14204	WASHER, LOCK	1	1	1	1	
16	90170-14171	NUT	1	1	1	1	
17	93311-32261	BEARING	1	1	1	1	
18	5NL-11631-20	PISTON (STD)	1	1	1	1	
19	5NL-11603-00	PISTON RING SET (STD)	1	1	1	1	
20	5NL-11633-00	PIN, PISTON	1	1	1	1	
21	93420-16086	CIRCLIP	2	2	2	2	

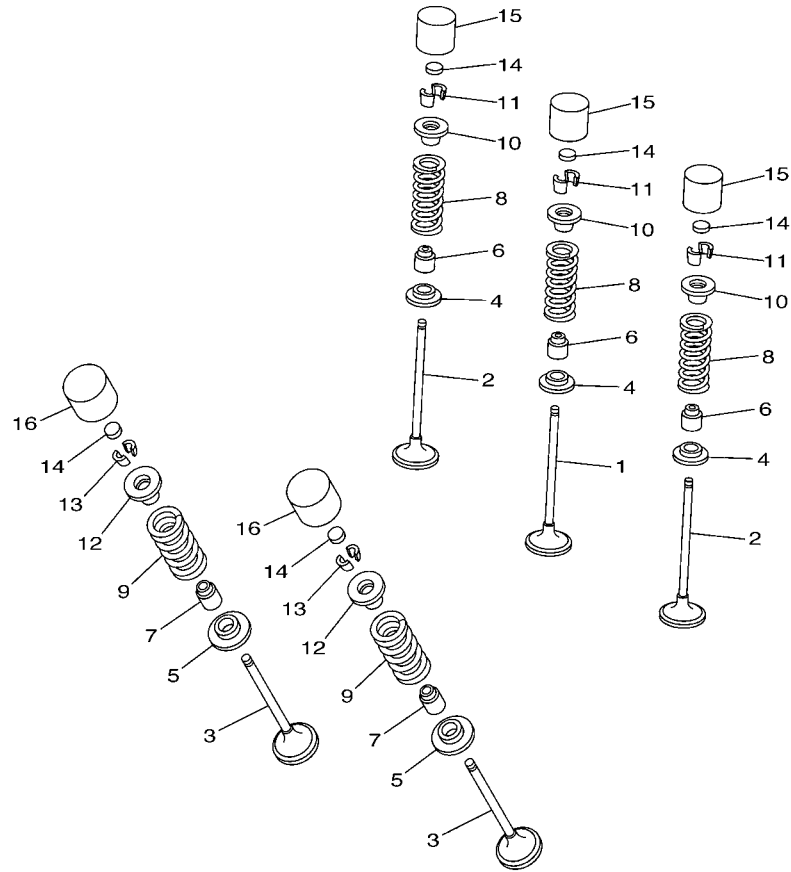

FIG. 3 VALVE

REF. NO.	PART NO.	DESCRIPTION	5XC5	5XC6	5XC7	5XC8	REMARKS
1	5NL-12111-10	VALVE, INTAKE	1	1	1	1	
2	5NL-12112-10	VALVE, INTAKE 2	2	2	2	2	
3	5NL-12121-10	VALVE, EXHAUST	2	2	2	2	
4	5NL-12116-00	SEAT, VALVE SPRING	3	3	3	3	
5	3GM-12126-00	SEAT, VALVE SPRING 2	2	2	2	2	
6	4TV-12119-00	SEAL, VALVE STEM	3	3	3	3	
7	4SV-12119-00	SEAL, VALVE STEM	2	2	2	2	
8	5NL-12113-00	SPRING, VALVE INNER	3	3	3	3	
9	5NL-12114-00	SPRING, VALVE OUTER	2	2	2	2	
10	1HX-12117-00	RETAINER, VALVE SPRING	3	3	3	3	
11	1HX-12118-00	COTTER, VALVE	6	6	6	6	
12	1WG-12117-00	RETAINER, VALVE SPRING	2	2	2	2	
13	1WG-12118-00	COTTER, VALVE	4	4	4	4	
14	1HX-12168-00	PAD, ADJUSTING 2 (1.20)	5	5	5	5	UR
	1HX-12168-20	PAD, ADJUSTING 2 (1.25)	5	5	5	5	UR
	1HX-12168-40	PAD, ADJUSTING 2 (1.30)	5	5	5	5	UR
	1HX-12168-60	PAD, ADJUSTING 2 (1.35)	5	5	5	5	UR
	1HX-12168-80	PAD, ADJUSTING 2 (1.40)	5	5	5	5	UR
	1HX-12168-A0	PAD, ADJUSTING 2 (1.45)	5	5	5	5	UR
	1HX-12168-F0	PAD, ADJUSTING 2 (1.50)	5	5	5	5	UR
	1HX-12168-H1	PAD, ADJUSTING 2 (1.55)	5	5	5	5	UR
	1HX-12168-K1	PAD, ADJUSTING 2 (1.60)	5	5	5	5	UR
	1HX-12168-M1	PAD, ADJUSTING 2 (1.65)	5	5	5	5	UR
	1HX-12168-R1	PAD, ADJUSTING 2 (1.70)	5	5	5	5	UR
	1HX-12168-U1	PAD, ADJUSTING 2 (1.75)	5	5	5	5	UR
	1HX-12168-W1	PAD, ADJUSTING 2 (1.80)	5	5	5	5	UR
	1HX-12168-Y1	PAD, ADJUSTING 2 (1.85)	5	5	5	5	UR



5NL1100-1030

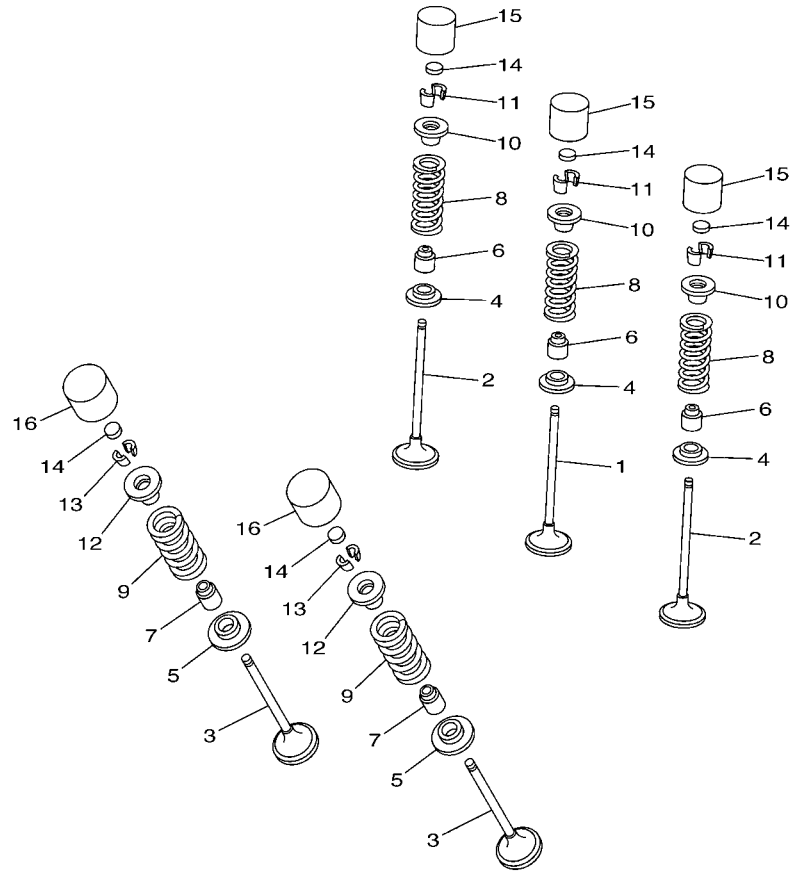

FIG. 3 VALVE

REF. NO.	PART NO.	DESCRIPTION	5XC5	5XC6	5XC7	5XC8	REMARKS
14	1HX-12169-11	PAD, ADJUSTING 2 (1.90)	5	5	5	5	UR
	1HX-12169-31	PAD, ADJUSTING 2 (1.95)	5	5	5	5	UR
	1HX-12169-50	PAD, ADJUSTING 2 (2.00)	5	5	5	5	UR
	1HX-12169-70	PAD, ADJUSTING 2 (2.05)	5	5	5	5	UR
	1HX-12169-90	PAD, ADJUSTING 2 (2.10)	5	5	5	5	UR
	1HX-12169-E0	PAD, ADJUSTING 2 (2.15)	5	5	5	5	UR
	1HX-12169-G0	PAD, ADJUSTING 2 (2.20)	5	5	5	5	UR
	1HX-12169-J0	PAD, ADJUSTING 2 (2.25)	5	5	5	5	UR
	1HX-12169-L0	PAD, ADJUSTING 2 (2.30)	5	5	5	5	UR
	1HX-12169-N0	PAD, ADJUSTING 2 (2.35)	5	5	5	5	UR
	1HX-12169-T0	PAD, ADJUSTING 2 (2.40)	5	5	5	5	UR
15	3LN-12153-10	LIFTER, VALVE	3	3	3	3	UR YELLOW
16	3FV-12153-10	LIFTER, VALVE	2	2	2	2	UR YELLOW



5NL1100-1030

FIG. 4 CAMSHAFT & CHAIN

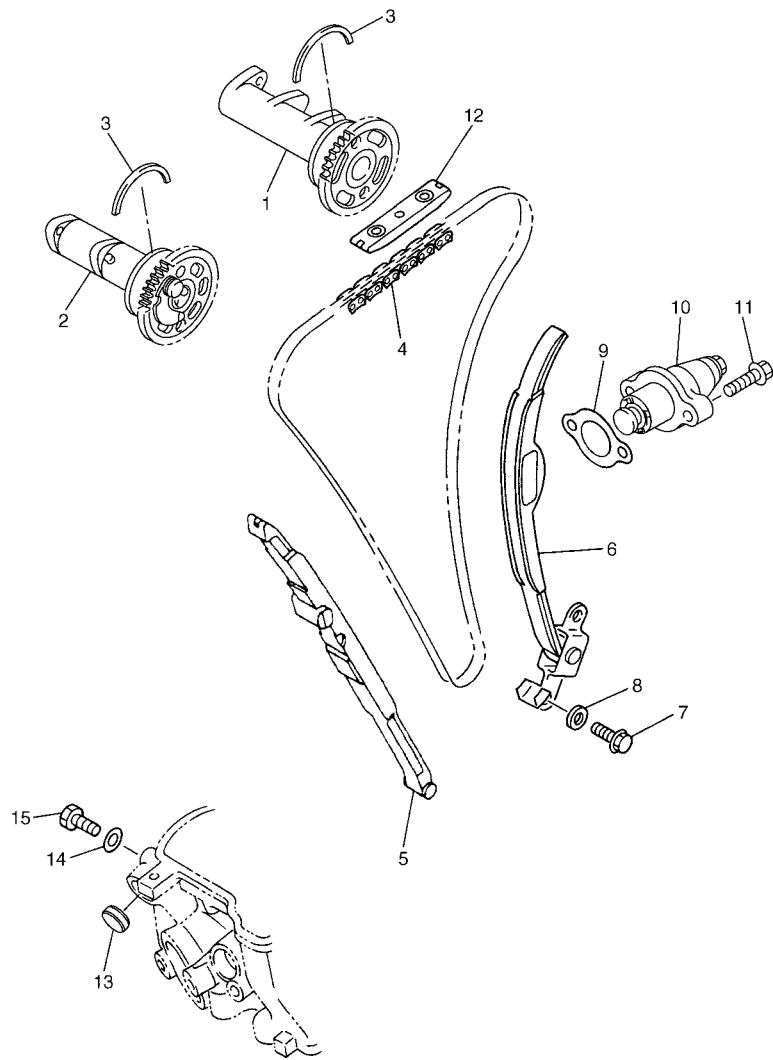

5UL1100-B040

REF. NO.	PART NO.	DESCRIPTION	5XC5	5XC6	5XC7	5XC8	REMARKS
1	5UL-12170-10	CAMSHAFT ASSY 1	1	1	1	1	
2	5UL-12180-10	CAMSHAFT ASSY 2	1	1	1	1	
3	93440-41178	CIRCLIP	2	2	2	2	
4	94591-53114	CHAIN	1	1	1	1	
5	5NL-12251-10	DAMPER, CHAIN 1	1	1	1	1	
6	5NL-12252-00	DAMPER, CHAIN 2	1	1	1	1	
7	97027-06016	BOLT	2	2	2	2	
8	92907-06600	WASHER, PLATE	2	2	2	2	
9	4FM-12213-00	GASKET, TENSIONER CASE	1	1	1	1	
10	5TA-12210-00	TENSIONER ASSY, CAM CHAIN	1	1	1	1	
11	95027-06025	BOLT, FLANGE	2	2	2	2	
12	5BE-12241-00	GUIDE, STOPPER 2	1	1	1	1	
13	90338-18004	PLUG	1	1	1	1	
14	90430-06014	GASKET	1	1	1	1	
15	90109-06418	BOLT	1	1	1	1	

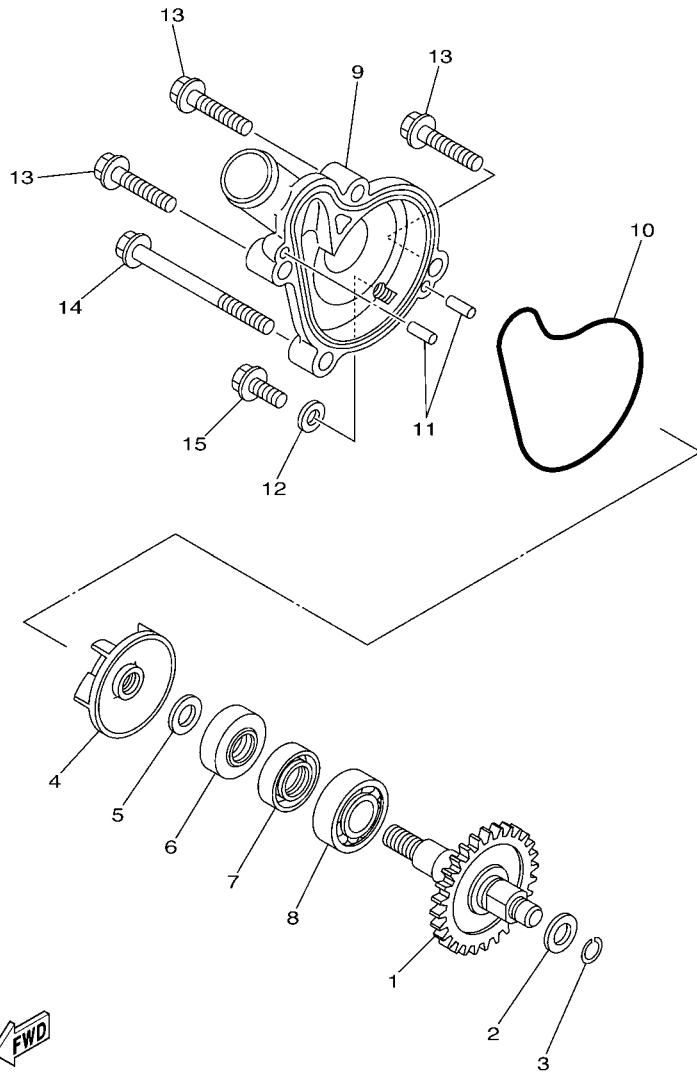

5NL1100-1050

FIG. 5 WATER PUMP

REF. NO.	PART NO.	DESCRIPTION	5XC5	5XC6	5XC7	5XC8	REMARKS
1	5XC-12459-00	GEAR, IMPELLER SHAFT	1	1	1	1	
2	90201-08512	WASHER, PLATE	1	1	1	1	
3	93440-07182	CIRCLIP	1	1	1	1	
4	5DH-12451-00	IMPELLER, WATER PUMP	1	1	1	1	
5	90201-08512	WASHER, PLATE	1	1	1	1	
6	93109-11073	OIL SEAL	1	1	1	1	
7	93102-12106	OIL SEAL (SD 12-22-5 HS)	1	1	1	1	
8	93306-00105	BEARING (B6001)	1	1	1	1	
9	5NL-12422-10	COVER, HOUSING	1	1	1	1	
10	5NL-12439-00	O-RING	1	1	1	1	
11	93604-10011	PIN, DOWEL	2	2	2	2	
12	90430-06014	GASKET	1	1	1	1	
13	95027-06025	BOLT, FLANGE	3	3	3	3	
14	95027-06065	BOLT, FLANGE	1	1	1	1	
15	95027-06012	BOLT, FLANGE	1	1	1	1	

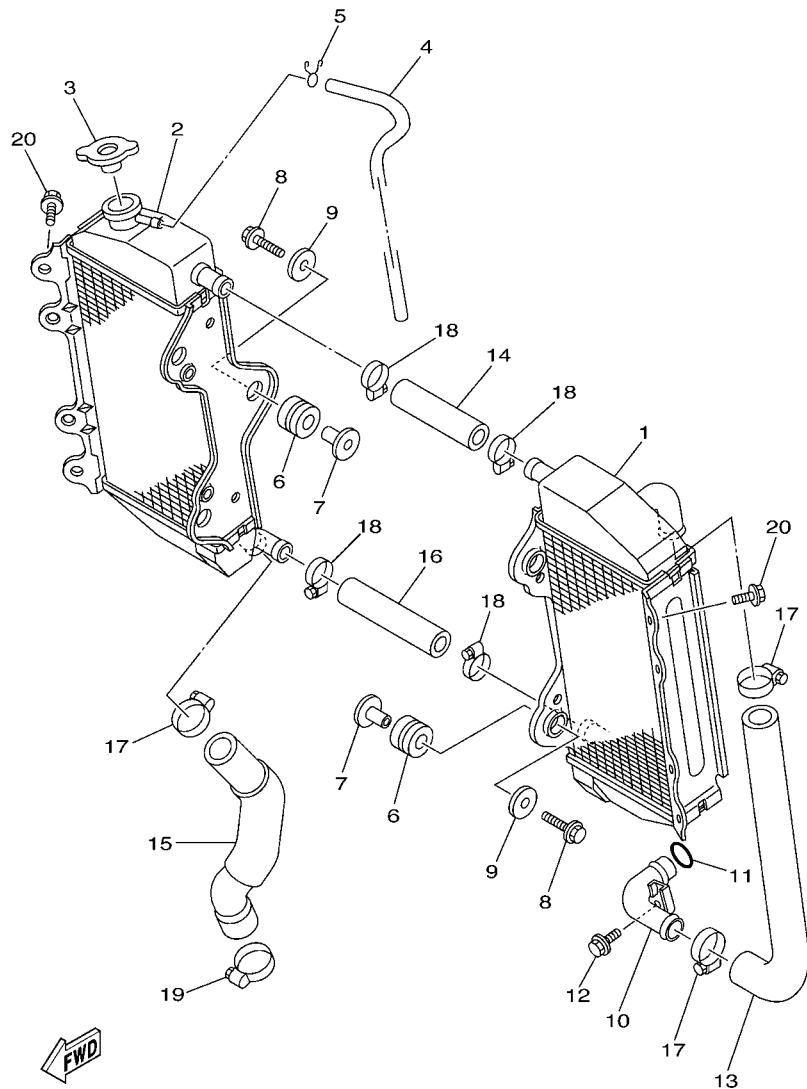

5NL1100-1060

FIG. 6 RADIATOR & HOSE

REF. NO.	PART NO.	DESCRIPTION	5XC5	5XC6	5XC7	5XC8	REMARKS
1	5NL-1240A-10	RADIATOR ASSY	1	1	1	1	
2	5NL-12461-10	RADIATOR ASSY	1	1	1	1	
3	5HD-12462-00	CAP, RADIATOR	1	1	1	1	
4	91A20-05065	TUBE, FLEXIBLE VINYL	1	1	1	1	
5	90467-09006	CLIP	1	1	1	1	
6	90480-15528	GROMMET	6	6	6	6	
7	90387-06065	COLLAR	6	6	6	6	
8	95027-06025	BOLT, FLANGE	6	6	6	6	
9	90201-06571	WASHER, PLATE	6	6	6	6	
10	5NL-12481-00	PIPE 1	1	1	1	1	
11	93210-15414	O-RING	1	1	1	1	
12	91317-06012	BOLT	1	1	1	1	
13	5SG-12576-00	HOSE 1	1	1	1	1	
14	5SG-12577-00	HOSE 2	1	1	1	1	
15	5SG-12578-00	HOSE 3	1	1	1	1	
16	5SG-12579-00	HOSE 4	1	1	1	1	
17	90450-25037	HOSE CLAMP ASSY	3	3	3	3	
18	90450-22017	HOSE CLAMP ASSY	4	4	4	4	
19	90450-32015	HOSE CLAMP ASSY	1	1	1	1	
20	95827-06010	BOLT, FLANGE	2	2	2	2	

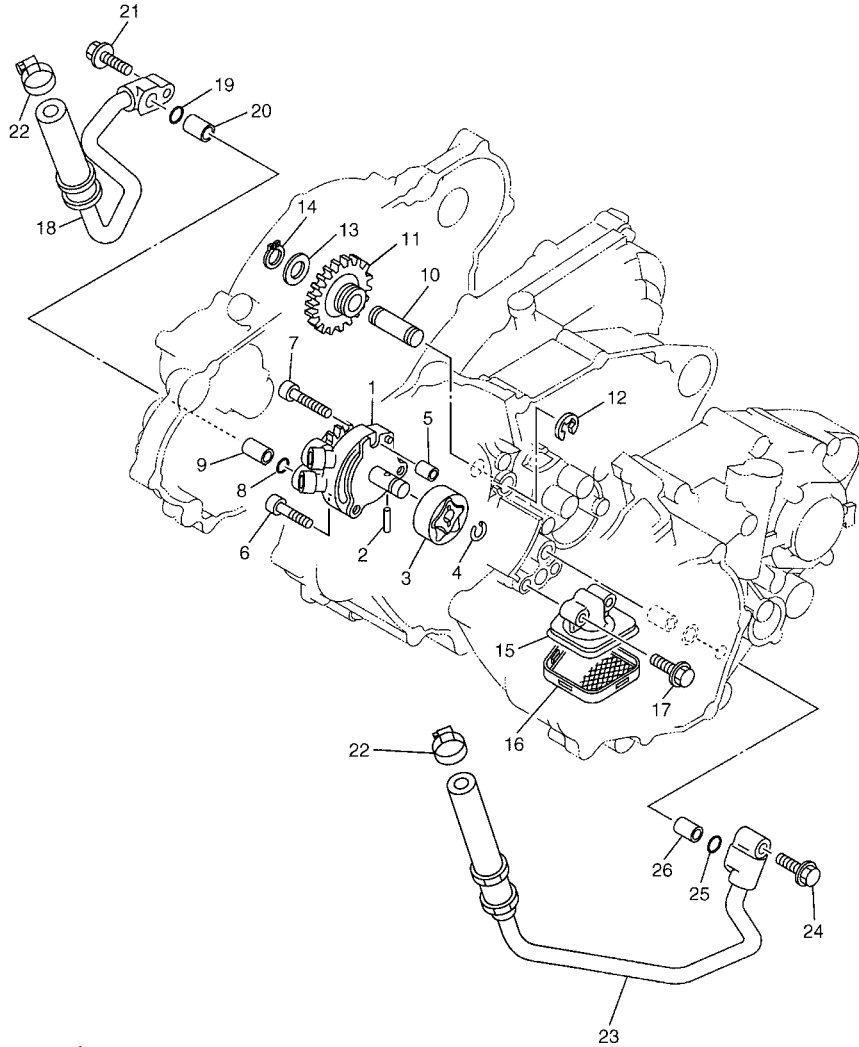

5UL1100-B070

FIG. 7 OIL PUMP

REF. NO.	PART NO.	DESCRIPTION	5XC5	5XC6	5XC7	5XC8	REMARKS
1	5SG-13300-00	OIL PUMP ASSY	1	1	1	1	
2	93603-16219	PIN, DOWEL	1	1	1	1	
3	5NL-13320-00	ROTOR ASSY 2	1	1	1	1	
4	93440-10153	CIRCLIP	1	1	1	1	
5	99530-08012	PIN, DOWEL	1	1	1	1	
6	90110-06058	BOLT, HEXAGON SOCKET HEAD	2	2	2	2	
7	91314-06030	BOLT	1	1	1	1	
8	93210-10197	O-RING	1	1	1	1	
9	99530-10114	PIN, DOWEL	1	1	1	1	
10	5BE-13342-00	SHAFT, IDLE GEAR	1	1	1	1	
11	5NL-13341-00	GEAR, OIL PUMP IDLE	1	1	1	1	
12	99001-08600	CIRCLIP	1	1	1	1	
13	90201-12166	WASHER, PLATE	1	1	1	1	
14	99009-12400	CIRCLIP	1	1	1	1	
15	5NL-13412-00	HOUSING, STRAINER	1	1	1	1	
16	5NL-13411-00	STRAINER, OIL	1	1	1	1	
17	95027-06025	BOLT, FLANGE	2	2	2	2	
18	5XC-13464-00	HOSE, OIL 1	1	1	1	1	
19	93210-10197	O-RING	1	1	1	1	
20	99530-10114	PIN, DOWEL	1	1	1	1	
21	95027-06025	BOLT, FLANGE	1	1	1	1	
22	90450-22017	HOSE CLAMP ASSY	2	2	2	2	
23	5XC-13465-00	HOSE, OIL 2	1	1	1	1	
24	95027-06025	BOLT, FLANGE	1	1	1	1	
25	93210-10197	O-RING	1	1	1	1	
26	99530-10114	PIN, DOWEL	1	1	1	1	

FIG. 8 OIL CLEANER

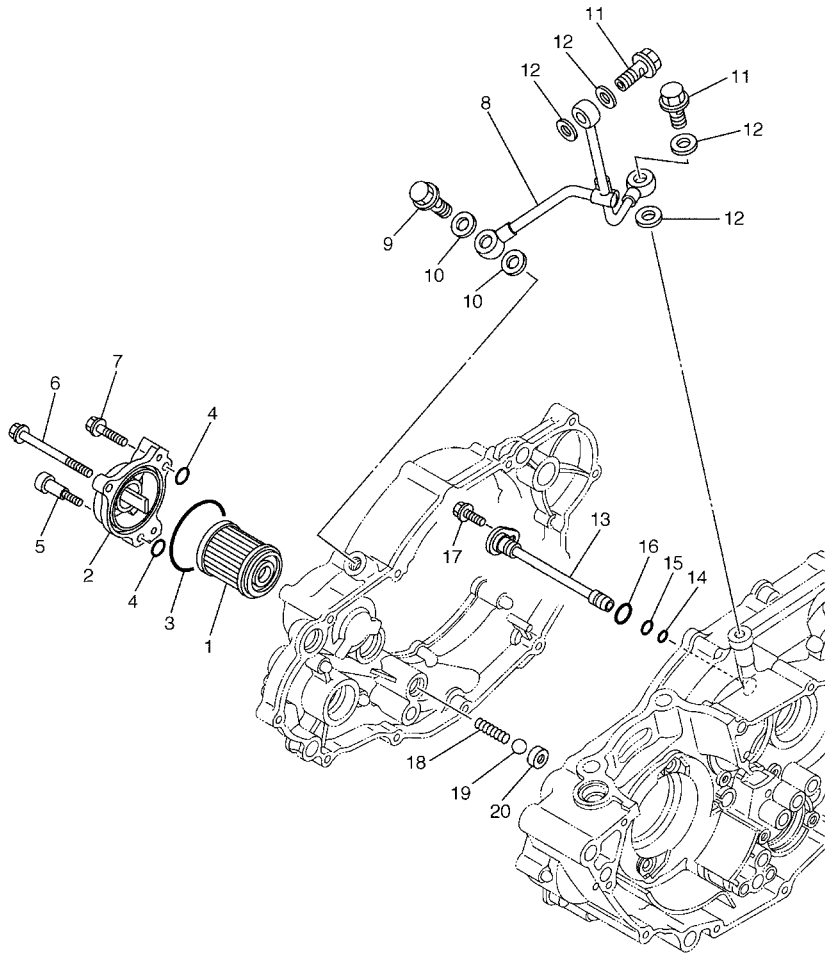

REF. NO.	PART NO.	DESCRIPTION	5XC5	5XC6	5XC7	5XC8	REMARKS
1	5TA-13440-00	ELEMENT ASSY, OIL CLEANER	1	1	1	1	
2	5BE-13447-10	COVER, OIL ELEMENT	1	1	1	1	
3	93210-47675	O-RING	1	1	1	1	
4	93210-07135	O-RING	3	3	3	3	
5	90109-065G2	BOLT	1	1	1	1	
6	91317-06065	BOLT	1	1	1	1	
7	91317-06025	BOLT	1	1	1	1	
8	5NL-13161-00	PIPE, DELIVERY 1	1	1	1	1	
9	90401-10159	BOLT, UNION	1	1	1	1	
10	90430-10188	GASKET	2	2	2	2	
11	90401-08038	BOLT, UNION	2	2	2	2	
12	90430-08119	GASKET	4	4	4	4	
13	5NL-13171-00	PIPE, DELIVERY 2	1	1	1	1	
14	93210-07003	O-RING	1	1	1	1	
15	93210-09008	O-RING	1	1	1	1	
16	93210-12759	O-RING	1	1	1	1	
17	95027-06012	BOLT, FLANGE	1	1	1	1	
18	90501-043E0	SPRING, COMPRESSION	1	1	1	1	
19	93503-08007	BALL	1	1	1	1	
20	583-13113-00	SEAT, CHECK BALL	1	1	1	1	



5XC1100-C080

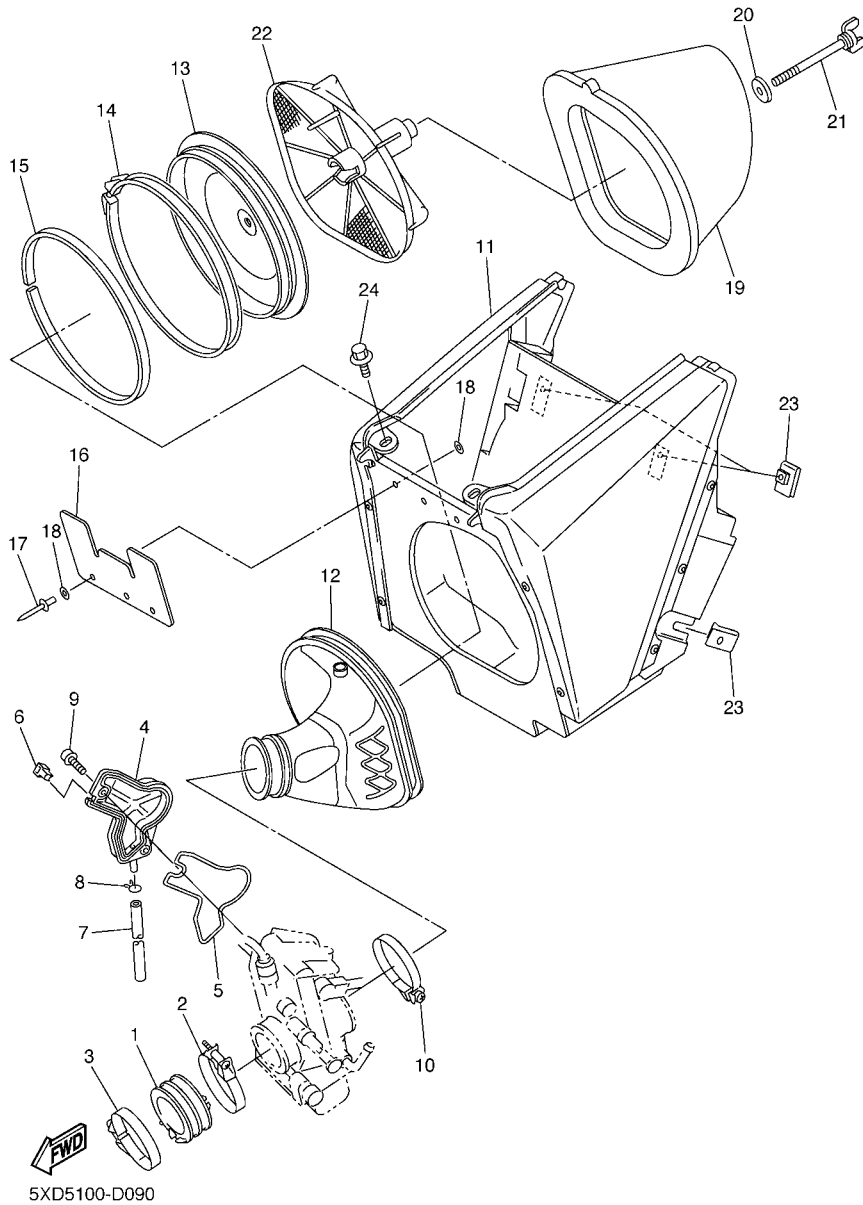
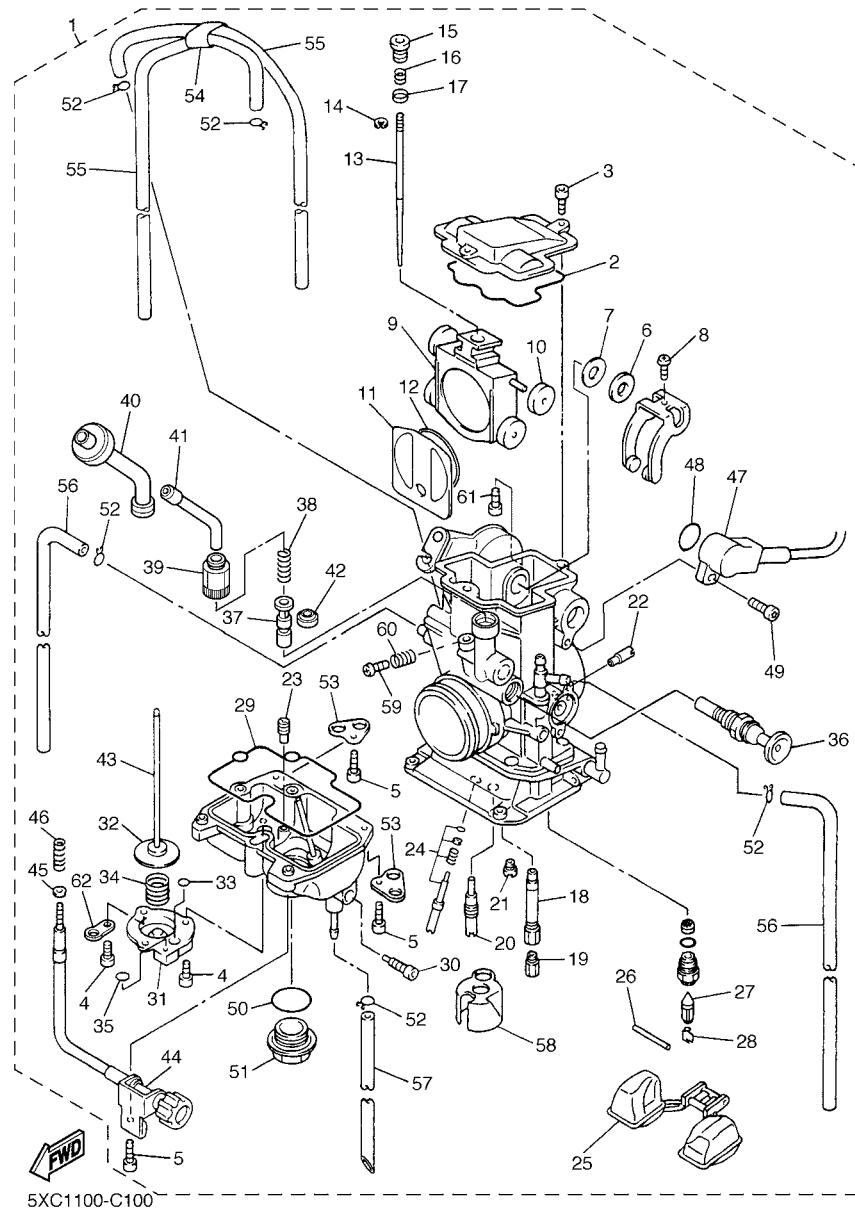

FIG. 9 INTAKE

REF. NO.	PART NO.	DESCRIPTION	5XC5	5XC6	5XC7	5XC8	REMARKS
1	5XC-13597-00	JOINT, CARBURETOR 3	1	1	1	1	
2	90450-57008	HOSE CLAMP ASSY	1	1	1	1	
3	90450-54002	HOSE CLAMP ASSY	1	1	1	1	
4	5TA-14293-00	COVER 1	1	1	1	1	
5	5TA-14227-00	GASKET	1	1	1	1	
6	5TA-14239-00	SEAL	1	1	1	1	
7	5TA-14987-00	HOSE	1	1	1	1	
8	3TJ-14137-40	CLIP	1	1	1	1	
9	5TA-14428-00	BOLT	2	2	2	2	
10	90450-61001	HOSE CLAMP ASSY	1	1	1	1	
11	5TA-14401-01	AIR CLEANER CASE ASSY	1	1	1	1	
12	5XD-14453-00	JOINT, AIR CLEANER 1	1	1	1	1	
13	5NY-14459-00	HOLDER, GUIDE	1	1	1	1	
14	5NY-14455-10	BAND	1	1	1	1	
15	5NY-14442-00	SPACER	1	1	1	1	
16	5XD-14417-00	COVER 1	1	1	1	1	
17	90267-32070	RIVET, BLIND	3	3	3	3	
18	90201-03313	WASHER, PLATE	6	6	6	6	
19	4XM-14451-00	ELEMENT, AIR CLEANER	1	1	1	1	
20	90209-06096	WASHER	1	1	1	1	
21	90122-06035	BOLT, WING	1	1	1	1	
22	5BE-14458-00	GUIDE	1	1	1	1	
23	90183-06023	NUT, SPRING	3	3	3	3	
24	90109-067F4	BOLT	2	2	2	2	



5XC1100-C100

FIG. 10 CARBURETOR

REF. NO.	PART NO.	DESCRIPTION	5XC5	5XC6	5XC7	5XC8	REMARKS
1	5XC-14101-50	CARBURETOR ASSY 1	1				
	5XC-14101-60	CARBURETOR ASSY 1		1	1	1	
2	5JG-14959-00	.GASKET	1	1	1	1	
3	91316-04012	.BOLT	2	2	2	2	
4	688-14592-00	.SCREW	3	3	3	3	
5	98502-04012	.SCREW, PAN HEAD	4	4	4	4	
6	90202-08045	.WASHER, PLATE	1	1	1	1	
7	5JG-14951-00	.WASHER	1	1	1	1	
8	5JG-14522-00	.SCREW, ADJUST	1	1	1	1	
9	5JG-14388-00	.VALVE, VACUUM CONTROL	1	1	1	1	
10	3TJ-14267-40	.ROLLER	1	1	1	1	
11	5JG-14546-01	.VALVE, NEEDLE	1	1	1	1	
12	4FN-14997-00	.SEAL	1	1	1	1	
13	5NL-14916-ER	.NEEDLE (#OBELR)	1				STD
	5JG-14916-ES	.NEEDLE (#OBEKS)		1	1	1	STD
	5NL-14916-EN	.NEEDLE (#OBELN)	1				AP
	5NL-14916-EP	.NEEDLE (#OBELP)	1				AP
	5NL-14916-E1	.NEEDLE (#OBELQ)	1				AP
	5NL-14916-ES	.NEEDLE (#OBELS)	1				AP
	5NL-14916-ET	.NEEDLE (#OBELT)	1				AP
	5NL-14916-EU	.NEEDLE (#OBELU)	1				AP
	5JG-14916-EP	.NEEDLE (#OBEKP)		1	1	1	AP
	5JG-14916-E1	.NEEDLE (#OBEKQ)		1	1	1	AP
	5JG-14916-ER	.NEEDLE (#OBEKR)		1	1	1	AP
	5JG-14916-ET	.NEEDLE (#OBEKT)		1	1	1	AP
	5JG-14916-EU	.NEEDLE (#OBEKU)		1	1	1	AP
	5JG-14916-EV	.NEEDLE (#OBEKV)		1	1	1	AP

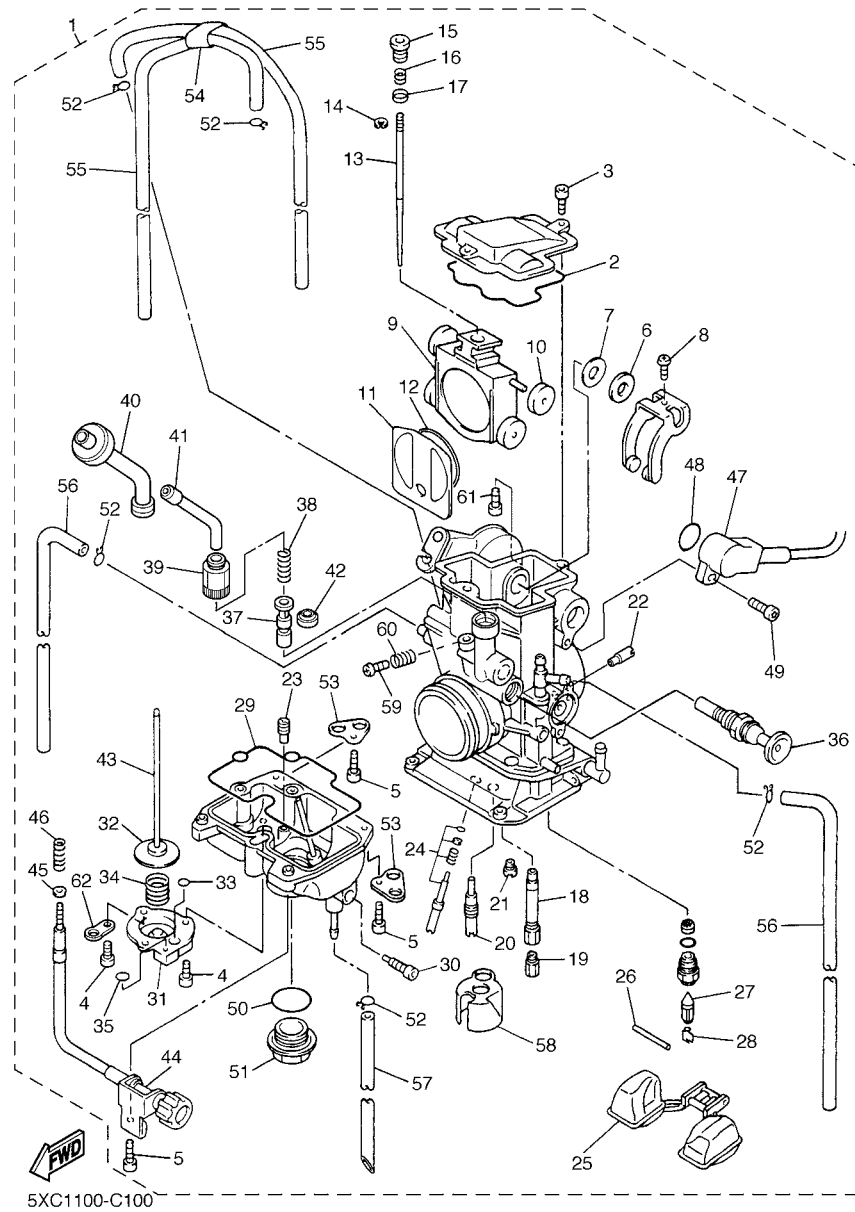

FIG. 10 CARBURETOR

REF. NO.	PART NO.	DESCRIPTION	5XC5	5XC6	5XC7	5XC8	REMARKS
14	3TJ-14159-40	.CLIP	1	1	1	1	
15	5JG-14521-00	.SCREW, ADJUST	1	1	1	1	
16	5JG-14275-00	.SPRING	1	1	1	1	
17	5JG-14264-00	.COLLAR	1	1	1	1	
18	5JG-14947-00	.NOZZLE, MAIN	1	1	1	1	
19	4MX-14943-94	.JET, MAIN (#182)	1	1	1	1	STD
	4MX-14943-92	.JET, MAIN (#172)	1	1	1	1	AP
	4MX-14943-42	.JET, MAIN (#175)	1	1	1	1	AP
	4MX-14943-93	.JET, MAIN (#178)	1	1	1	1	AP
	4MX-14943-43	.JET, MAIN (#180)	1	1	1	1	AP
	4MX-14943-44	.JET, MAIN (#185)	1	1	1	1	AP
	4MX-14943-95	.JET, MAIN (#188)	1	1	1	1	AP
	4MX-14943-45	.JET, MAIN (#190)	1	1	1	1	AP
	4MX-14943-96	.JET, MAIN (#192)	1	1	1	1	AP
20	4MX-14948-04	.JET, SLOW (#42)	1	1	1	1	STD
	4MX-14948-02	.JET, SLOW (#38)	1	1	1	1	AP
	4MX-14948-03	.JET, SLOW (#40)	1	1	1	1	AP
	4MX-14948-05	.JET, SLOW (#45)	1	1	1	1	AP
	4MX-14948-06	.JET, SLOW (#48)	1	1	1	1	AP
21	3TJ-1494F-16	.JET (#72)	1	1	1	1	STD
	3TJ-1494F-13	.JET (#65)	1	1	1	1	AP
	3TJ-1494F-14	.JET (#68)	1	1	1	1	AP
	3TJ-1494F-15	.JET (#70)	1	1	1	1	AP
	3TJ-1494F-17	.JET (#75)	1	1	1	1	AP
	3TJ-1494F-18	.JET (#78)	1	1	1	1	AP
	3TJ-1494F-19	.JET (#80)	1	1	1	1	AP
22	5TA-14943-27	.JET, MAIN (#100)	1	1	1	1	

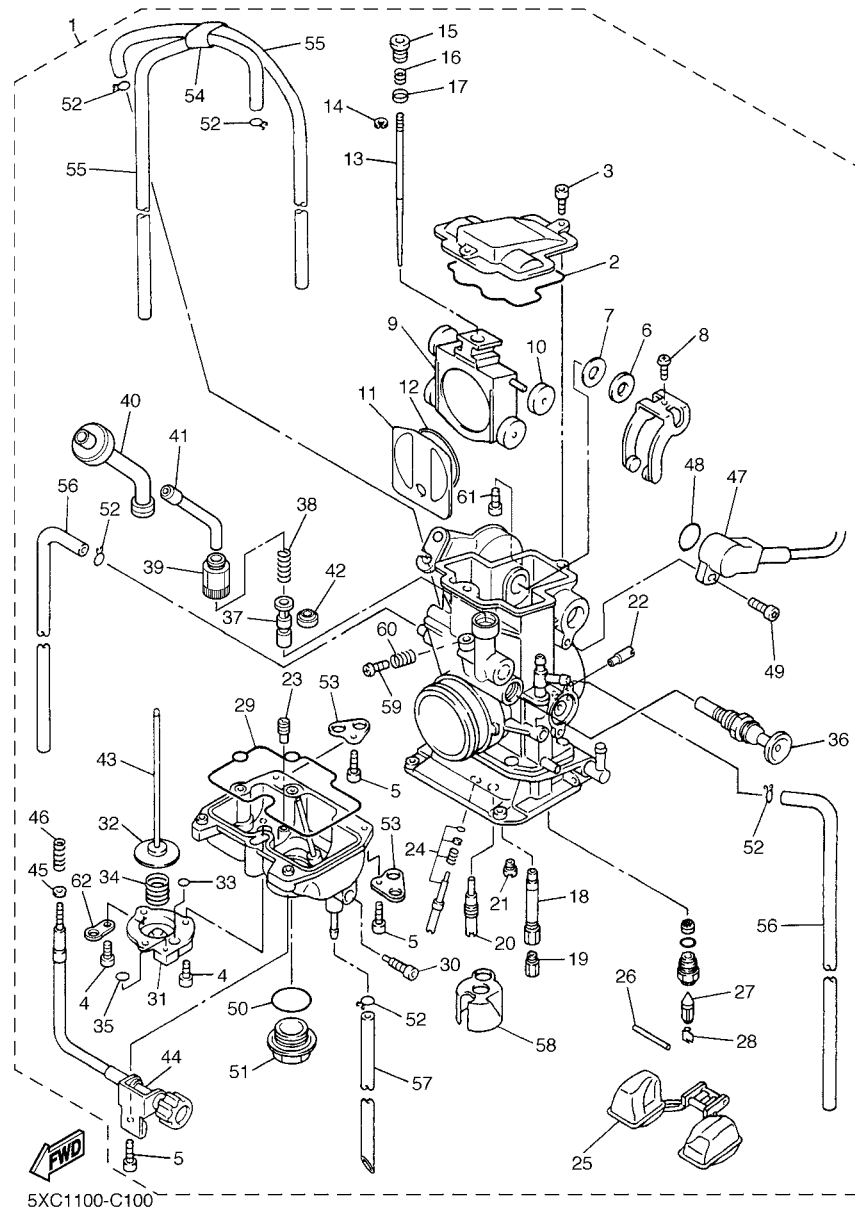
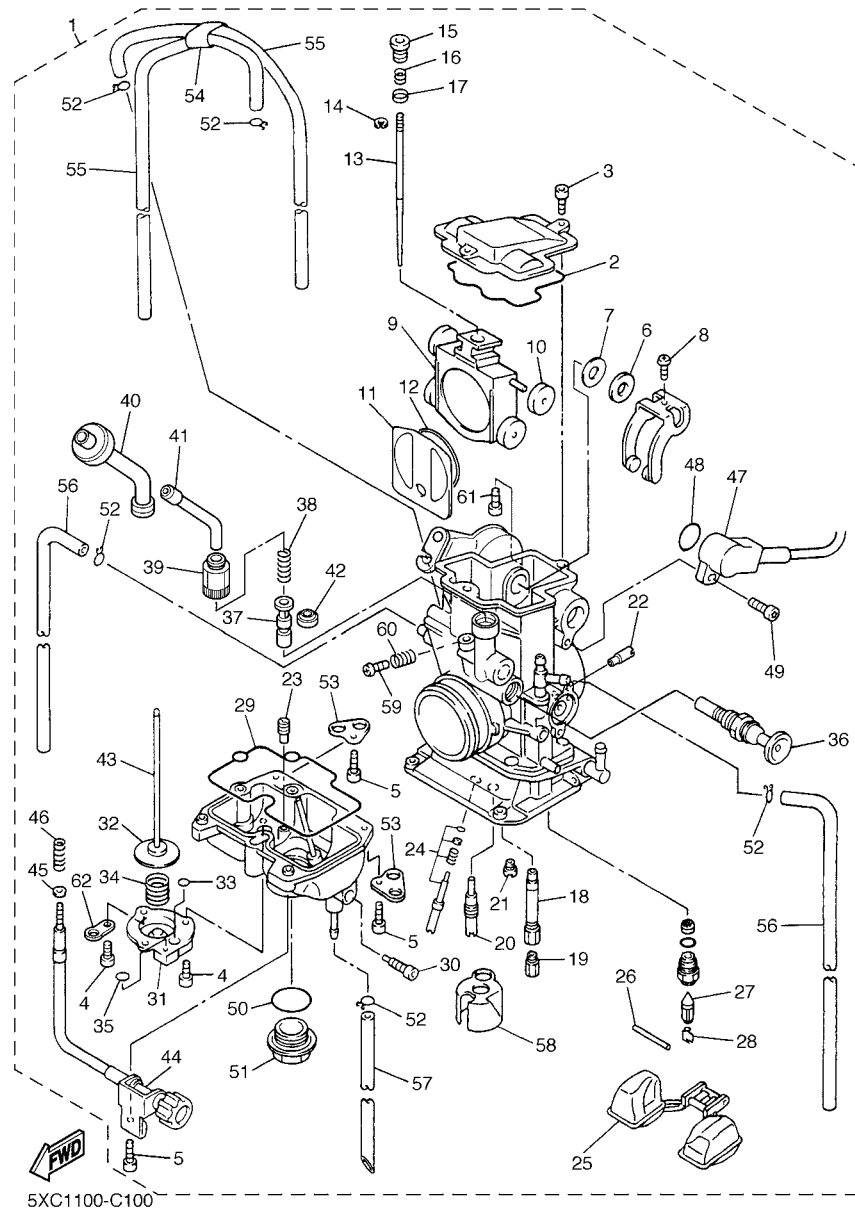

FIG. 10 CARBURETOR

REF. NO.	PART NO.	DESCRIPTION	5XC5	5XC6	5XC7	5XC8	REMARKS
23	4TJ-1494F-23	.JET (#90)	1				STD
	4TJ-1494F-25	.JET (#95)		1	1	1	STD
	4TJ-1494F-11	.JET (#60)	1				AP
	4TJ-1494F-13	.JET (#65)		1	1	1	AP
	4TJ-1494F-15	.JET (#70)	1				AP
	4TJ-1494F-17	.JET (#75)		1	1	1	AP
	4TJ-1494F-19	.JET (#80)	1				AP
	4TJ-1494F-21	.JET (#85)		1	1	1	AP
	4TJ-1494F-27	.JET (#100)	1				AP
	4TJ-1494F-28	.JET (#105)		1	1	1	AP
	4TJ-1494F-29	.JET (#110)	1				AP
	4TJ-1494F-30	.JET (#115)		1	1	1	AP
	4TJ-1494F-31	.JET (#120)	1				AP
	4TJ-1494F-32	.JET (#125)		1	1	1	AP
24	5NL-14105-00	.PILOT SCREW SET	1				
	3TJ-14105-40	.PILOT SCREW SET		1	1	1	
25	4SR-14985-00	.FLOAT	1	1	1	1	
26	676-14548-00	.PIN, FLOAT ARM	1	1	1	1	
27	4MX-14392-00	.VALVE, NEEDLE	1	1	1	1	
28	633-14159-00	.CLIP	1	1	1	1	
29	5JG-14984-00	.GASKET, FLOAT CHAMBER	1	1	1	1	
30	3TJ-14191-40	.PLUG, DRAIN	1	1	1	1	
31	3TJ-14293-40	.COVER 1	1	1	1	1	
32	5JG-14940-76	.DIAPHRAGM ASSY	1	1	1	1	STD
	5JG-14940-16	.DIAPHRAGM ASSY	1	1	1	1	AP
	5JG-14940-17	.DIAPHRAGM ASSY	1	1	1	1	AP
	5JG-14940-18	.DIAPHRAGM ASSY	1	1	1	1	AP



5XC1100-C100

FIG. 10 CARBURETOR

REF. NO.	PART NO.	DESCRIPTION	5XC5	5XC6	5XC7	5XC8	REMARKS
33	3TJ-14536-40	.GASKET	1	1	1	1	
34	3TJ-14933-40	.SPRING, DIAPHRAGM	1	1	1	1	
35	6H4-14561-00	.O-RING	1	1	1	1	
36	5TA-14171-00	.PLUNGER, STARTER	1	1	1	1	
37	5TA-14371-00	.PLUNGER, STARTER	1	1	1	1	
38	5TA-14335-00	.SPRING, PLUNGER	1	1	1	1	
39	5TA-14991-00	.SCREW	1	1	1	1	
40	5TA-14374-00	.CAP, PLUNGER	1	1	1	1	
41	5TA-14155-00	.GUIDE, CABLE	1	1	1	1	
42	5TA-14997-00	.SEAL	1	1	1	1	
43	5JG-14379-00	.ROD, STARTER	1	1	1	1	
44	5JG-14922-00	.SCREW, THROTTLE	1	1	1	1	
45	90201-08410	.WASHER, PLATE	1	1	1	1	
46	5TA-14934-00	.SPRING, THROTTLE STOP	1	1	1	1	
47	5TA-85885-00	.THROTTLE SENSOR ASSY	1	1	1	1	
48	5NX-14562-00	.O-RING	1	1	1	1	
49	5NX-14216-00	.SCREW	1	1	1	1	
50	4MX-14561-00	.O-RING	1	1	1	1	
51	4MX-14115-00	.PLUG, SCREW	1	1	1	1	
52	3TJ-14137-40	.CLIP	5	5	5	5	
53	5BE-14146-00	.PLATE	2	2	2	2	
54	5TA-14261-00	.HOLDER	1	1	1	1	
55	5UL-14196-00	.PIPE	2	2	2	2	
56	5TA-14197-00	.PIPE	2	2	2	2	
57	5TJ-14987-00	.HOSE	1	1	1	1	
58	5JG-14346-00	.PLATE	1	1	1	1	
59	5JG-14565-00	.SCREW	1	1	1	1	

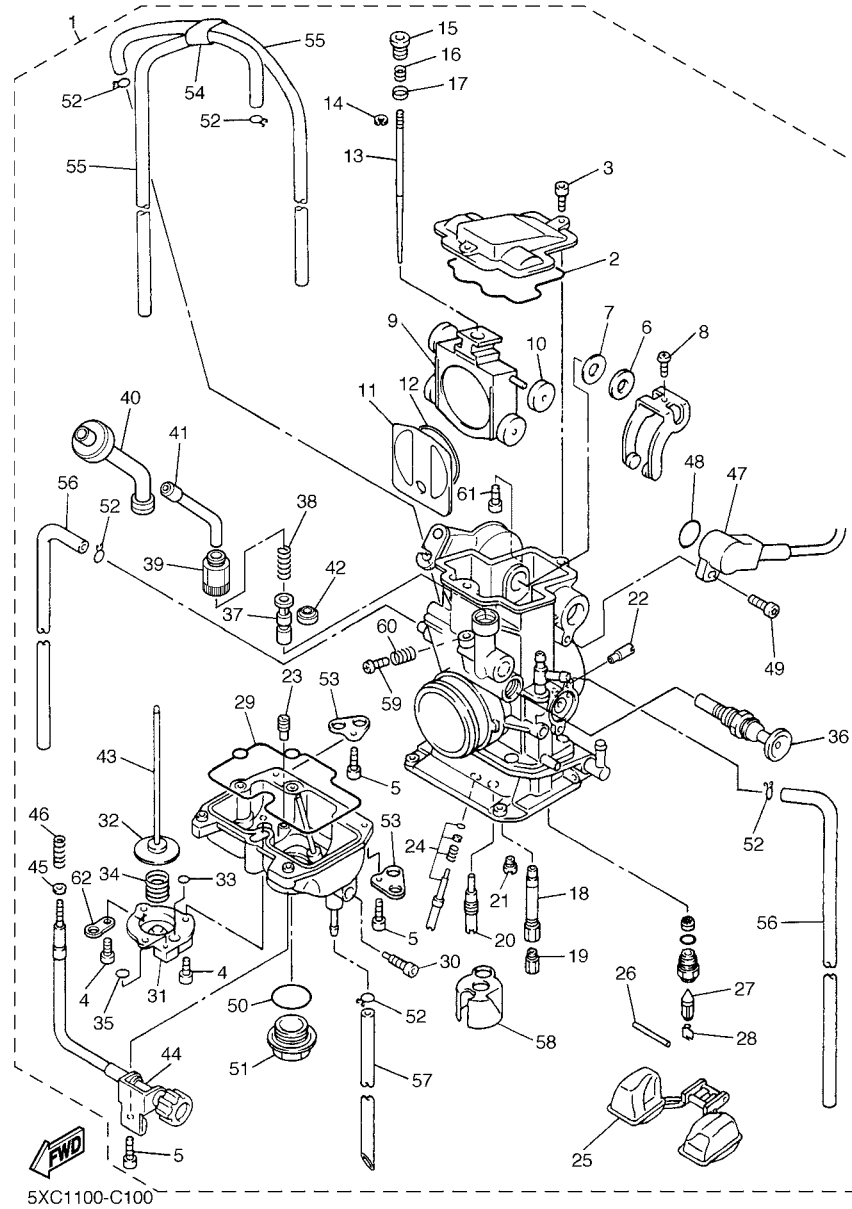

5XC1100-C100

FIG. 10 CARBURETOR

REF. NO.	PART NO.	DESCRIPTION	5XC5	5XC6	5XC7	5XC8	REMARKS
60	5JG-14531-00	.SPRING, ADJUST SCREW	1	1	1	1	
61	5NL-14591-00	.SCREW	1	1	1	1	
62	5PA-14146-00	.PLATE	1	1	1	1	

EXCEPT FOR USA

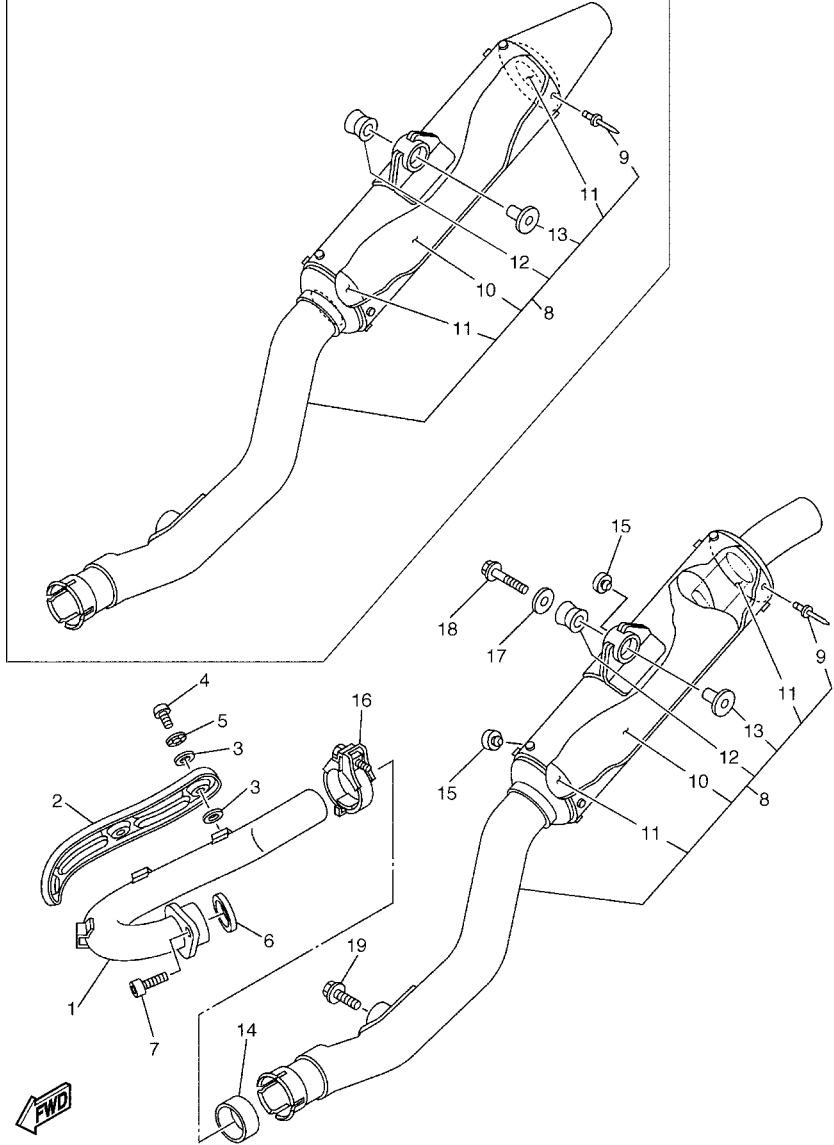
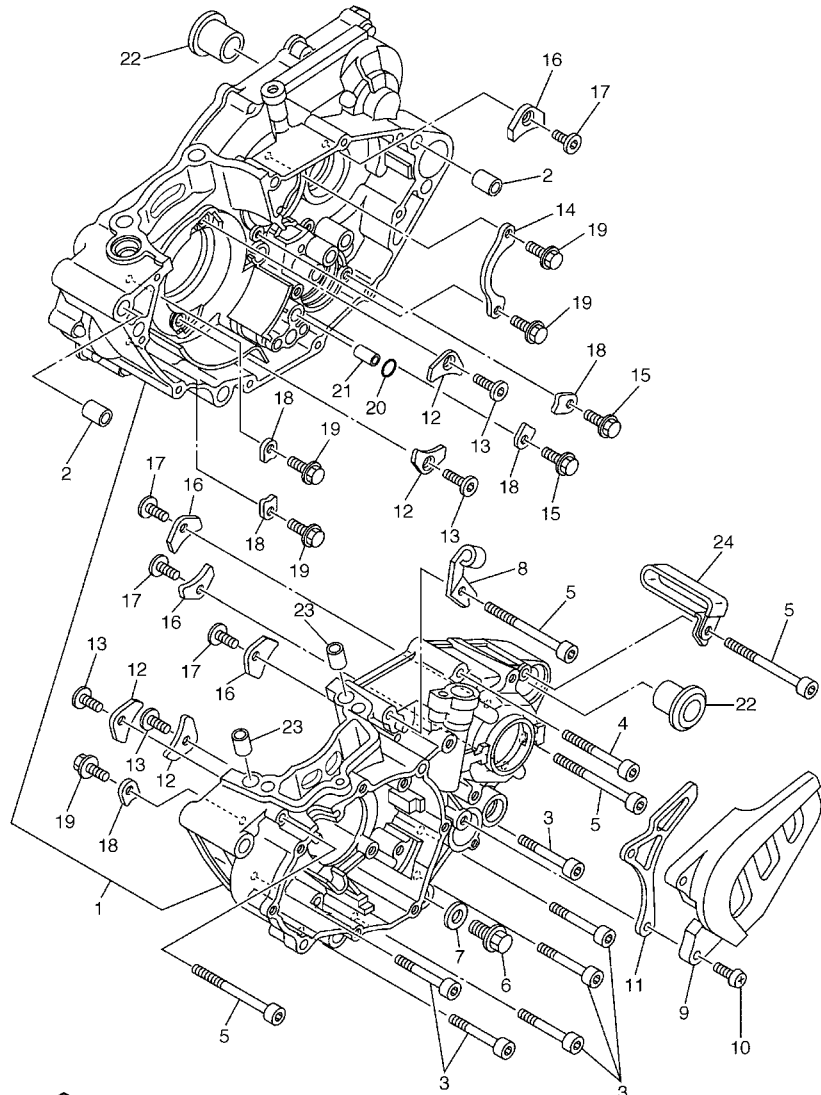

FIG. 11 EXHAUST

REF. NO.	PART NO.	DESCRIPTION	5XC5	5XC6	5XC7	5XC8	REMARKS
1	5XC-14611-00	PIPE, EXHAUST 1	1	1	1	1	
2	5XC-14628-00	PROTECTOR, EXHAUST PIPE	1	1	1	1	
3	4BD-14766-00	WASHER, PROTECTOR	6	6	6	6	
4	98980-06008	SCREW, BIND	3	3	3	3	
5	90206-06090	WASHER, WAVE	3	3	3	3	
6	5NL-14613-00	GASKET, EXHAUST PIPE	1	1	1	1	
7	91317-08020	BOLT	1	1	1	1	
8	5UL-Y1475-01	SILENCER ASSY	1				
	5UL-Y1475-30	SILENCER ASSY		1	1	1	
9	90267-48121	.RIVET, BLIND	16	16	16	16	
10	5NL-1469A-00	.FIBER	1	1	1	1	
11	5BE-1469E-00	.FIBER	2	2	2	2	
12	5BE-14747-00	.DAMPER, MUFFLER	1	1	1	1	
13	90387-0814J	.COLLAR	1	1	1	1	
14	3VD-14755-00	GASKET, SILENCER	1	1	1	1	
15	22W-24181-00	DAMPER, LOCATING 1	2	2	2	2	
16	5UL-14788-00	BAND, SILENCER	1	1	1	1	
17	90201-08008	WASHER, PLATE	1	1	1	1	
18	90105-08659	BOLT, FLANGE	1	1	1	1	
19	90105-08057	BOLT, FLANGE	1	1	1	1	



5XC1100-C120

FIG. 12 CRANKCASE

REF. NO.	PART NO.	DESCRIPTION	5XC5	5XC6	5XC7	5XC8	REMARKS
1	5XC-15150-00	CRANKCASE ASSY	1	1	1	1	
2	93612-16254	PIN, DOWEL	2	2	2	2	
3	91317-06045	BOLT	6	6	6	6	
4	91317-06055	BOLT	1	1	1	1	
5	91317-06070	BOLT	4	4	4	4	
6	95027-10016	BOLT, FLANGE	1	1	1	1	
7	90430-10188	GASKET	1	1	1	1	
8	5NL-15441-01	HOLDER, CLUTCH CABLE	1	1	1	1	
9	5BE-15421-01	COVER, CRANKCASE 2	1	1	1	1	
10	98507-06025	SCREW, PAN HEAD	2	2	2	2	
11	5NL-17466-00	GUIDE, CHAIN	1	1	1	1	
12	5BE-15383-01	PLATE, BEARING COVER	4	4	4	4	
13	90149-06126	SCREW	4	4	4	4	
14	5NL-15388-00	PLATE, BEARING COVER	1	1	1	1	
15	90105-06553	BOLT, FLANGE	2	2	2	2	
16	4JT-15381-01	PLATE, BEARING COVER	4	4	4	4	
17	90149-06326	SCREW	4	4	4	4	
18	5DH-18562-00	PLATE, STOPPER 2	5	5	5	5	
19	90105-06553	BOLT, FLANGE	5	5	5	5	
20	93210-10197	O-RING	1	1	1	1	
21	99530-10114	PIN, DOWEL	1	1	1	1	
22	90387-18007	COLLAR	2	2	2	2	
23	99530-10116	PIN, DOWEL	2	2	2	2	
24	90465-10013	CLAMP	1	1	1	1	

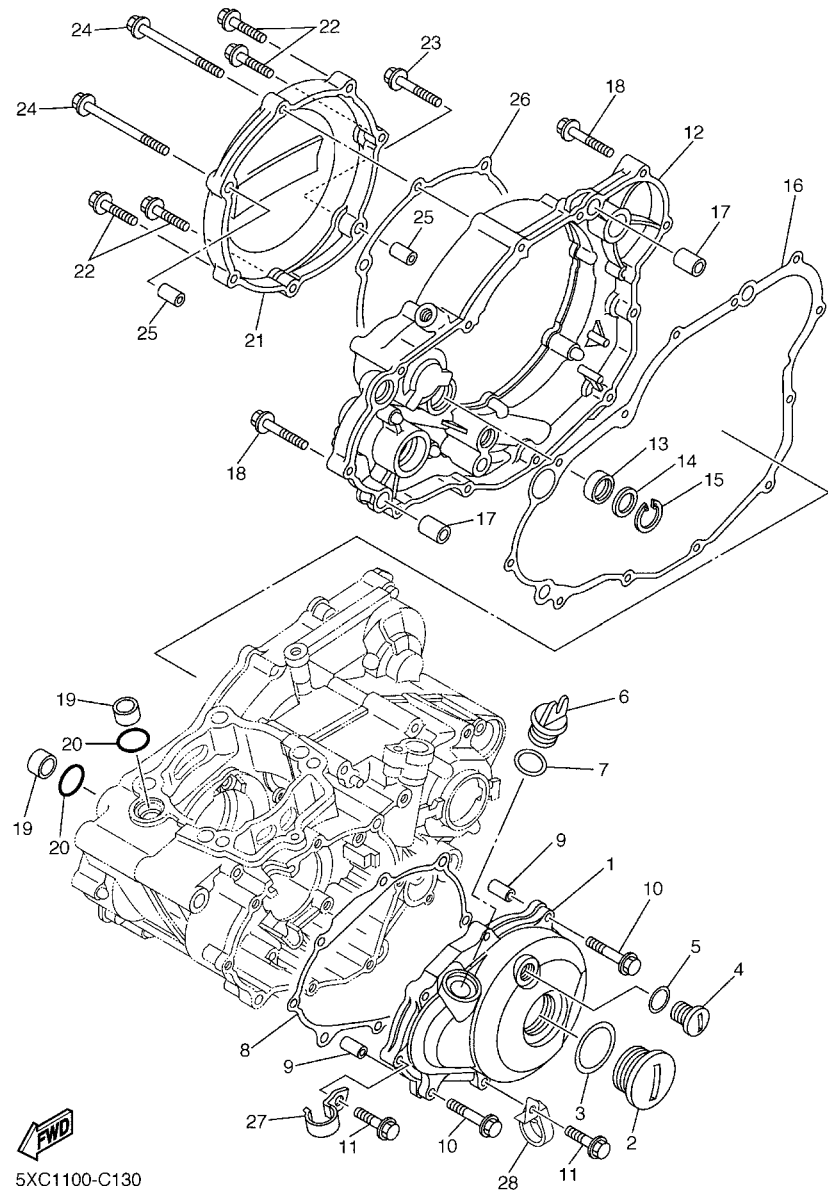

FWD
5XC1100-C130

FIG. 13 CRANKCASE COVER 1

REF. NO.	PART NO.	DESCRIPTION	5XC5	5XC6	5XC7	5XC8	REMARKS
1	5NL-15411-10	COVER, CRANKCASE 1	1	1	1	1	
2	90340-32123	PLUG, STRAIGHT SCREW	1	1	1	1	
3	93210-32172	O-RING	1	1	1	1	
4	90340-14128	PLUG, STRAIGHT SCREW	1	1	1	1	
5	93210-14369	O-RING	1	1	1	1	
6	3Y1-15363-00	PLUG, OIL	1	1	1	1	
7	93210-19123	O-RING	1	1	1	1	
8	5NL-15451-00	GASKET, CRANKCASE COVER 1	1	1	1	1	
9	99530-08016	PIN, DOWEL	2	2	2	2	
10	95027-06035	BOLT, FLANGE	2	2	2	2	
11	95027-06025	BOLT, FLANGE	6	6	6	6	
12	5NL-15431-10	COVER, CRANKCASE 3	1	1	1	1	
13	93101-14164	OIL SEAL	1	1	1	1	
14	90201-15701	WASHER, PLATE (T=1.0)	1	1	1	1	
15	99009-22500	CIRCLIP	1	1	1	1	
16	5NL-15462-00	GASKET, CRANKCASE COVER 3	1	1	1	1	
17	91812-16001	PIN, DOWEL	2	2	2	2	
18	95027-06035	BOLT, FLANGE	8	8	8	8	
19	5NL-12564-00	PIPE, WATER	2	2	2	2	
20	93210-16716	O-RING	2	2	2	2	
21	5NL-15415-00	COVER 1	1	1	1	1	
22	95027-06025	BOLT, FLANGE	4	4	4	4	
23	95027-06035	BOLT, FLANGE	1	1	1	1	
24	90105-065A1	BOLT, FLANGE	2	2	2	2	
25	99530-08016	PIN, DOWEL	2	2	2	2	
26	5NL-15453-00	GASKET 1	1	1	1	1	
27	90465-08029	CLAMP	1	1	1	1	

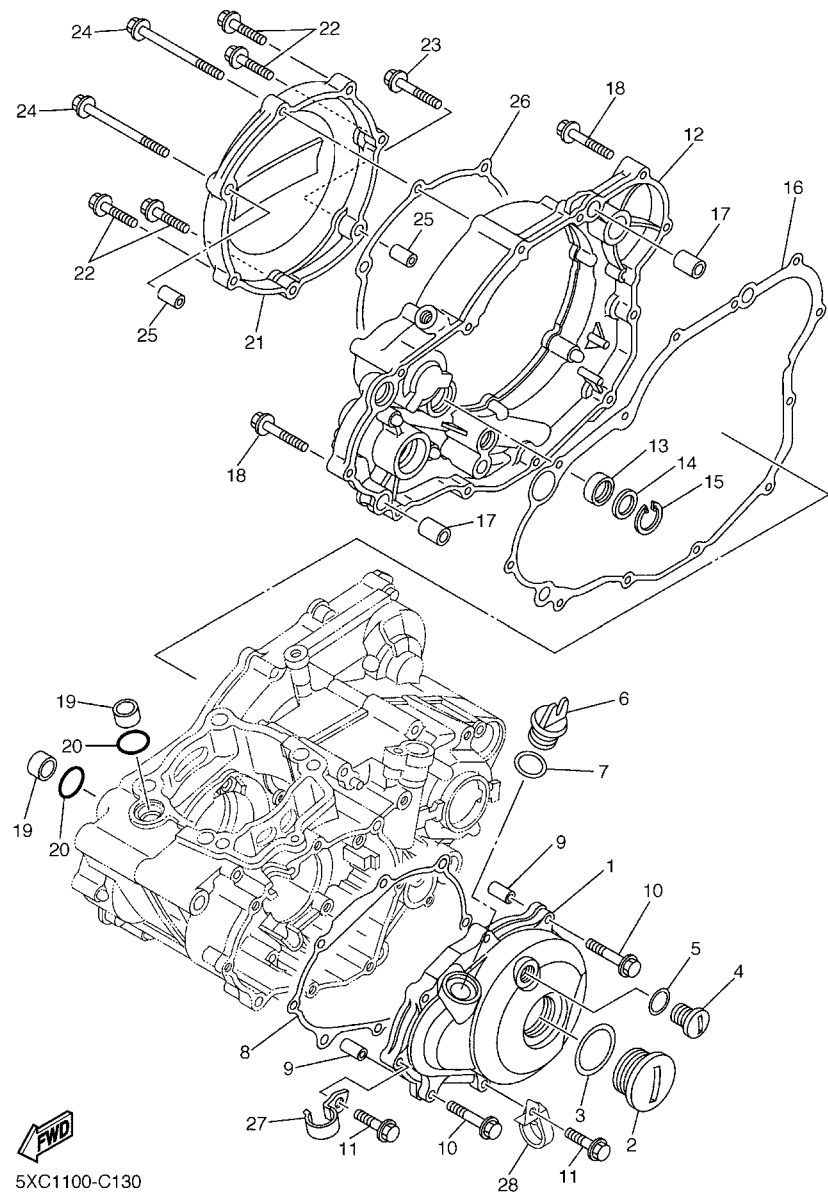

5XC1100-C130

FIG. 13 CRANKCASE COVER 1

REF. NO.	PART NO.	DESCRIPTION	5XC5	5XC6	5XC7	5XC8	REMARKS
28	5XD-15378-00	HOLDER	1	1	1	1	

FIG. 14 STARTER

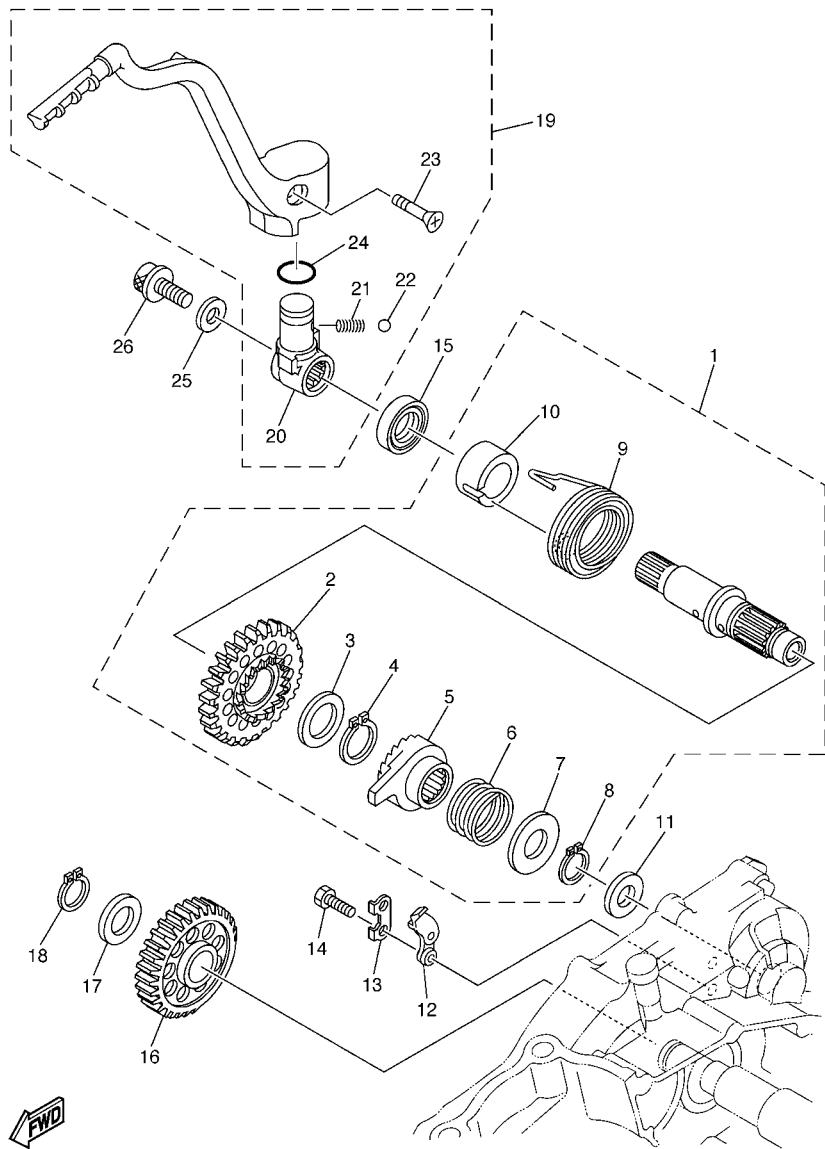

5SG1100-2140

REF. NO.	PART NO.	DESCRIPTION	5XC5	5XC6	5XC7	5XC8	REMARKS
1	5NL-15601-00	KICK SHAFT ASSY	1	1	1	1	
2	5NL-15641-00	.GEAR, KICK	1	1	1	1	
3	90201-20685	.WASHER, PLATE (T=0.5)	1	1	1	1	
4	93410-20038	.CIRCLIP	1	1	1	1	
5	4GY-15671-00	.WHEEL, RATCHET	1	1	1	1	
6	90501-16016	.SPRING, COMPRESSION	1	1	1	1	
7	90201-167P7	.WASHER, PLATE	1	1	1	1	
8	99009-16400	.CIRCLIP	1	1	1	1	
9	90508-30743	.SPRING, TORSION	1	1	1	1	
10	5NL-15664-00	.GUIDE, SPRING	1	1	1	1	
11	90201-162H4	WASHER, PLATE	1	1	1	1	
12	5SG-15668-00	STOPPER	1	1	1	1	
13	214-15686-00	WASHER, LOCK	1	1	1	1	
14	90101-06001	BOLT	2	2	2	2	
15	93102-18278	OIL SEAL	1	1	1	1	
16	5NL-15651-00	GEAR, KICK IDLE	1	1	1	1	
17	90201-177G4	WASHER, PLATE	1	1	1	1	
18	99009-17400	CIRCLIP	1	1	1	1	
19	5NL-15620-10	KICK CRANK ASSY	1	1	1	1	
20	5NX-15621-10	.BOSS, KICK CRANK	1	1	1	1	
21	90501-147A5	.SPRING, COMPRESSION	1	1	1	1	
22	93507-32009	.BALL	1	1	1	1	
23	90152-06010	.SCREW, COUNTERSUNK	1	1	1	1	
24	93210-17570	.O-RING	1	1	1	1	
25	90201-08326	WASHER, PLATE	1	1	1	1	
26	90109-082G0	BOLT	1	1	1	1	

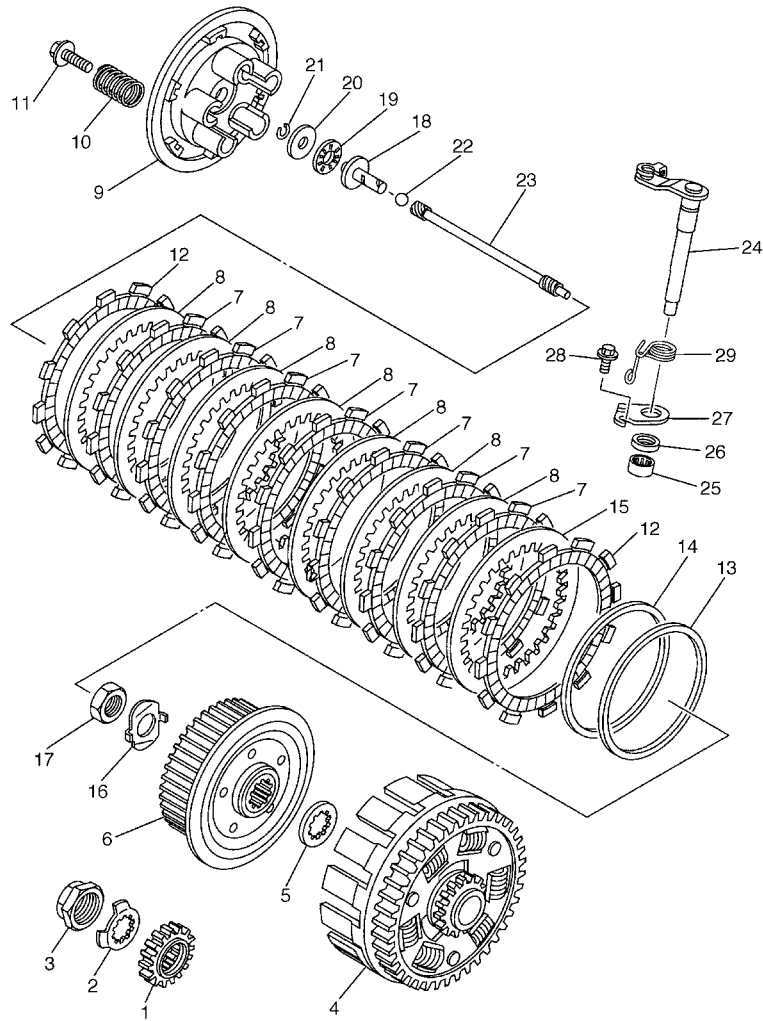

5XC5100-D150

FIG. 15 CLUTCH

REF. NO.	PART NO.	DESCRIPTION	5XC5	5XC6	5XC7	5XC8	REMARKS
1	5NL-16111-00	GEAR, PRIMARY DRIVE	1	1	1	1	
2	90215-20003	WASHER, LOCK	1	1	1	1	
3	90179-18001	NUT	1	1	1	1	
4	5NL-16150-10	PRIMARY DRIVEN GEAR COMP.	1	1	1	1	
5	5NL-16154-00	PLATE, THRUST 1	1	1	1	1	
6	5NL-16371-00	BOSS, CLUTCH	1	1	1	1	
7	5DH-16321-00	PLATE, FRICTION	7	7	7	7	
8	5NL-16325-00	PLATE, CLUTCH 2	7	7	7	7	
9	5HD-16351-00	PLATE, PRESSURE 1	1	1	1	1	
10	90501-224J9	SPRING, COMPRESSION	5	5	5	5	(PINK)
11	90159-06092	SCREW, WITH WASHER	5	5	5	5	
12	3XJ-16321-00	PLATE, FRICTION	2	2	2	2	
13	5NL-16384-00	PLATE, SEAT	1	1	1	1	
14	5NL-16383-10	SPRING, CLUTCH BOSS	1	1	1	1	
15	5NL-16325-10	PLATE, CLUTCH 2	1	1	1	1	
16	90215-16289	WASHER, LOCK	1	1	1	1	
17	90170-16326	NUT	1	1	1	1	
18	5NL-16356-00	ROD, PUSH 1	1	1	1	1	
19	93340-21008	BEARING	1	1	1	1	
20	90201-080H1	WASHER, PLATE	1	1	1	1	
21	93440-07182	CIRCLIP	1	1	1	1	
22	93511-32027	BALL	1	1	1	1	
23	5NL-16357-10	ROD, PUSH 2	1	1	1	1	
24	5JG-16381-00	PUSH LEVER COMP.	1	1	1	1	
25	93317-11287	BEARING	1	1	1	1	
26	93102-12224	OIL SEAL	1	1	1	1	
27	4JT-16384-00	PLATE, SEAT	1	1	1	1	

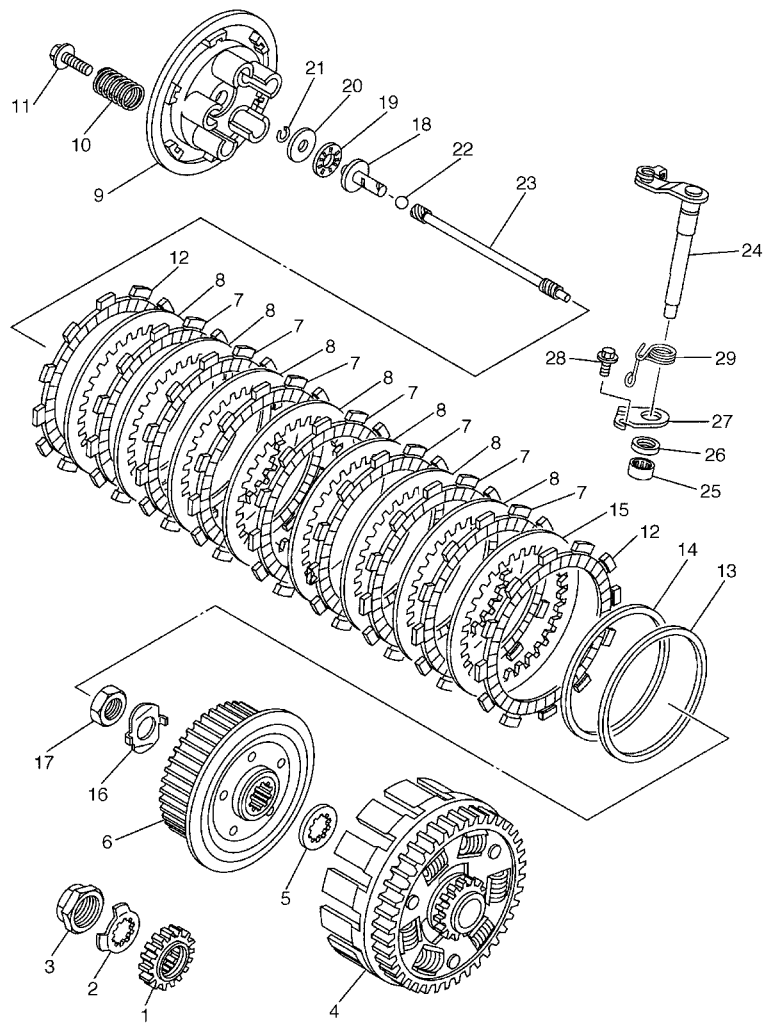

5XC5100-D150

FIG. 15 CLUTCH

REF. NO.	PART NO.	DESCRIPTION	5XC5	5XC6	5XC7	5XC8	REMARKS
28	95027-06010	BOLT, FLANGE	1	1	1	1	
29	90508-12018	SPRING, TORSION	1	1	1	1	

FIG. 16 TRANSMISSION

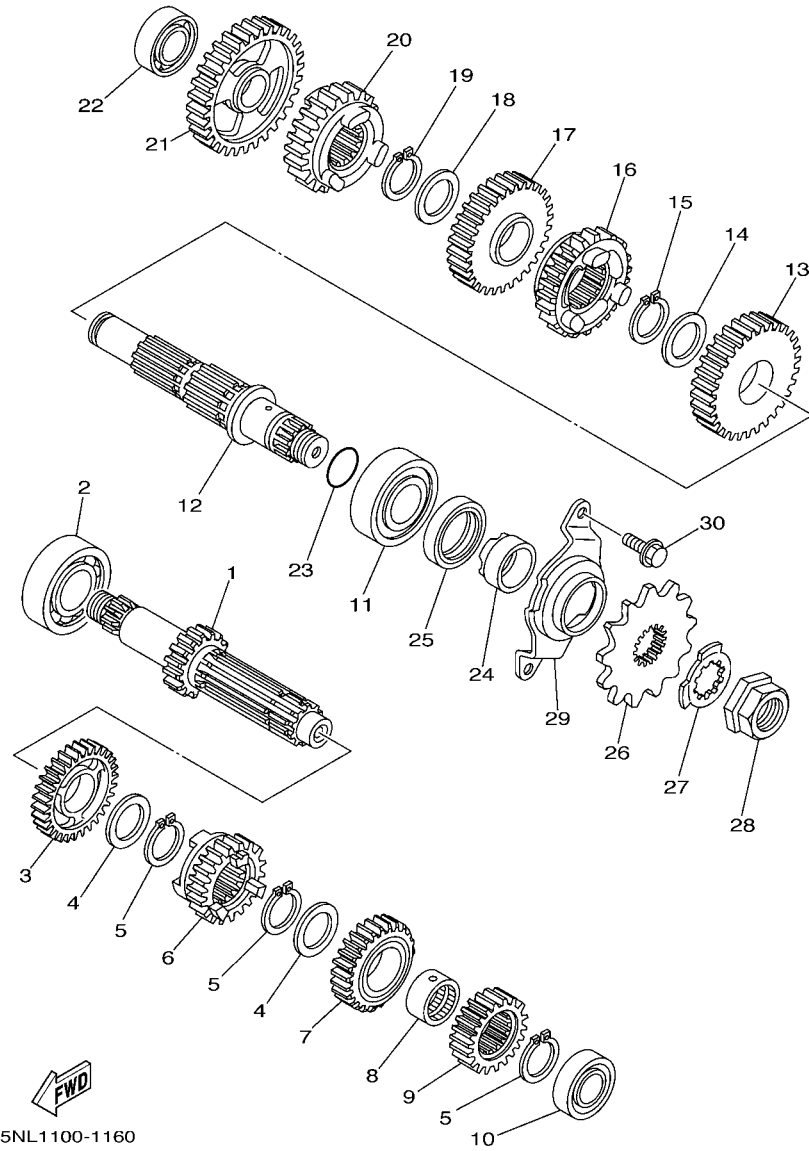

5NL1100-1160

REF. NO.	PART NO.	DESCRIPTION	5XC5	5XC6	5XC7	5XC8	REMARKS
1	5NL-17411-10	AXLE,MAIN (14T)	1	1	1	1	
2	93306-20447	BEARING	1	1	1	1	
3	5NL-17151-00	GEAR, 5TH PINION (24T)	1	1	1	1	
4	90209-20008	WASHER	2	2	2	2	
5	93410-22039	CIRCLIP	3	3	3	3	
6	5NL-17131-10	GEAR, 3RD PINION (20T)	1	1	1	1	
7	5NL-17141-10	GEAR, 4TH PINION (22T)	1	1	1	1	
8	90387-20006	COLLAR	1	1	1	1	
9	5NL-17121-00	GEAR, 2ND PINION (16T)	1	1	1	1	
10	93306-00320	BEARING	1	1	1	1	
11	93306-27208	BEARING	1	1	1	1	
12	5NL-17402-00	DRIVE AXLE ASSY	1	1	1	1	
13	5NL-17221-00	GEAR, 2ND WHEEL (28T)	1	1	1	1	
14	90209-23012	WASHER	1	1	1	1	
15	93410-26067	CIRCLIP	1	1	1	1	
16	5NL-17241-10	GEAR, 4TH WHEEL (27T)	1	1	1	1	
17	5NL-17231-10	GEAR, 3RD WHEEL (29T)	1	1	1	1	
18	90209-20008	WASHER	1	1	1	1	
19	93410-22039	CIRCLIP	1	1	1	1	
20	5NL-17251-10	GEAR, 5TH WHEEL (25T)	1	1	1	1	
21	5NL-17211-10	GEAR, 1ST WHEEL (30T)	1	1	1	1	
22	93306-00317	BEARING	1	1	1	1	
23	93210-196A4	O-RING	1	1	1	1	
24	90387-22001	COLLAR	1	1	1	1	
25	93102-28010	OIL SEAL	1	1	1	1	
26	9383B-13218	SPROCKET, DRIVE (13T)	1	1	1	1	
27	90215-20003	WASHER, LOCK	1	1	1	1	

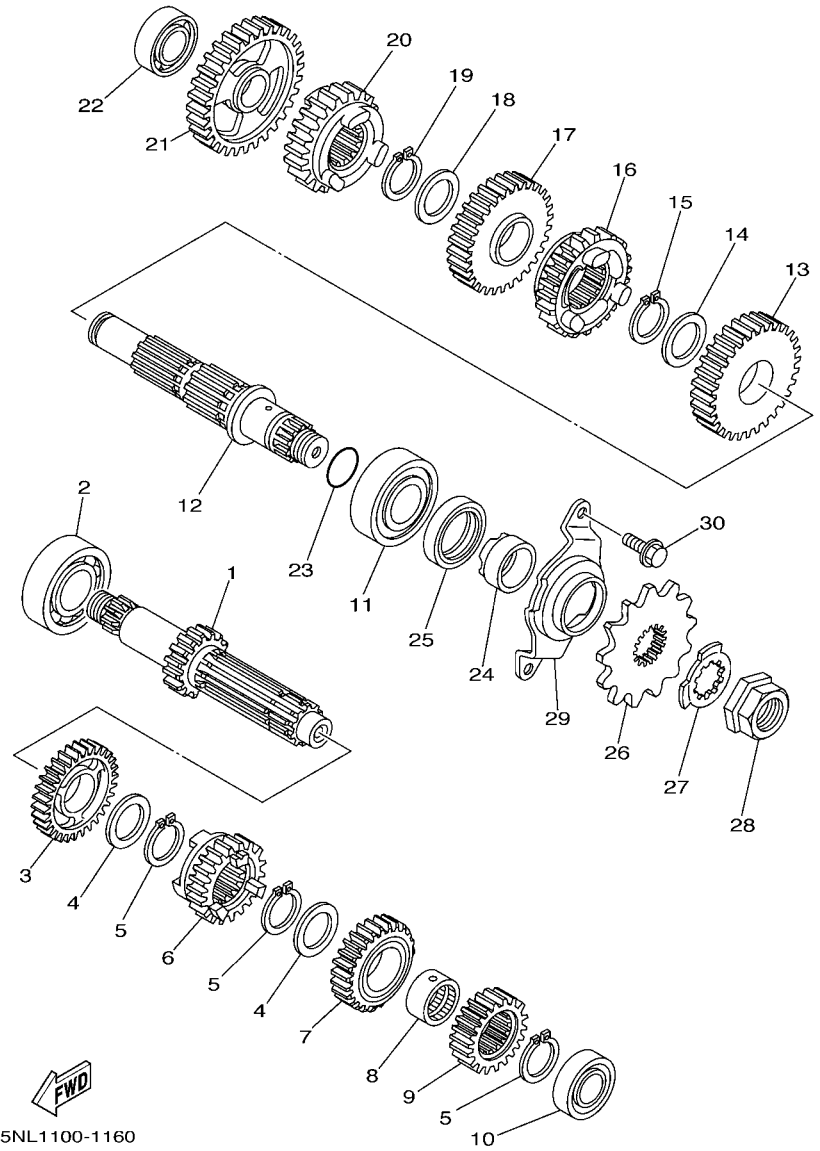
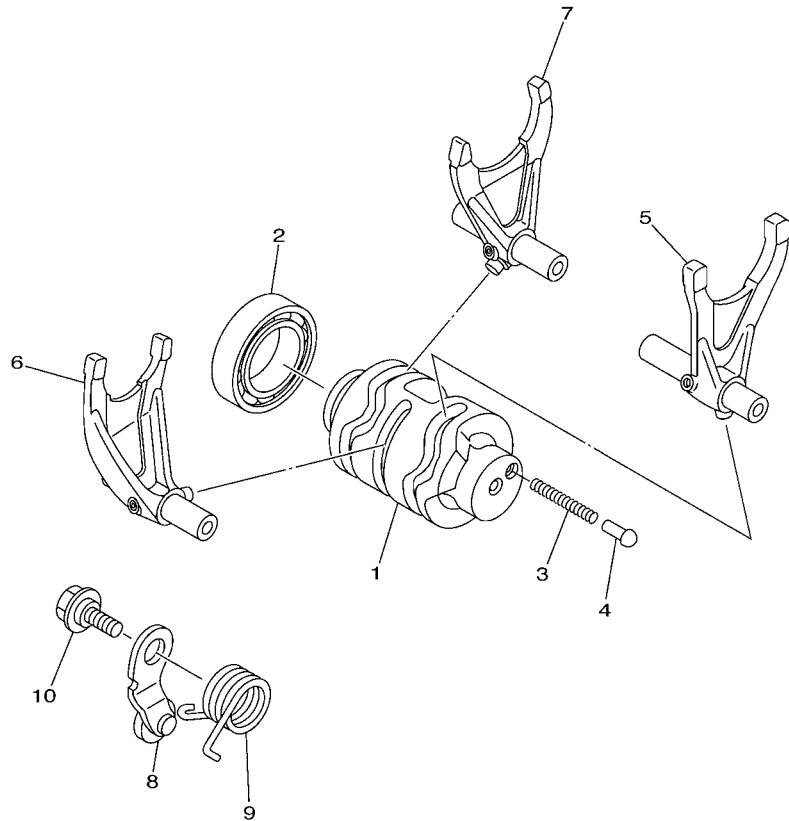

FIG. 16 TRANSMISSION

REF. NO.	PART NO.	DESCRIPTION	5XC5	5XC6	5XC7	5XC8	REMARKS
28	90179-18001	NUT	1	1	1	1	
29	5NL-17471-00	PLATE, COVER	1	1	1	1	
30	90105-06553	BOLT, FLANGE	2	2	2	2	

FIG. 17 SHIFT CAM & FORK



REF. NO.	PART NO.	DESCRIPTION	5XC5	5XC6	5XC7	5XC8	REMARKS
1	5NL-18541-00	CAM, SHIFT	1	1	1	1	
2	93306-90501	BEARING	1	1	1	1	
3	90501-06022	SPRING, COMPRESSION	1	1	1	1	
4	4BA-18542-00	POINT, NEUTRAL	1	1	1	1	
5	5NL-18501-00	FORK, SHIFT 1	1	1	1	1	
6	5NL-18502-00	FORK, SHIFT 2	1	1	1	1	
7	5NL-18503-00	FORK, SHIFT 3	1	1	1	1	
8	3XK-18140-00	STOPPER LEVER ASSY	1	1	1	1	
9	90508-26561	SPRING, TORSION	1	1	1	1	
10	90109-063F8	BOLT	1	1	1	1	

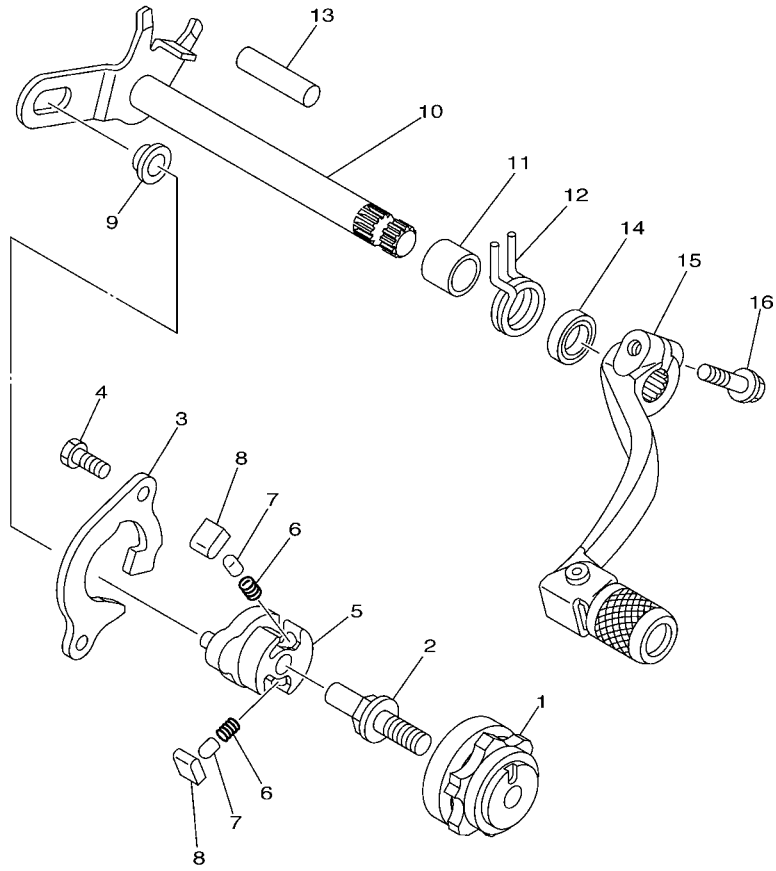

 5NL1100-1170

FIG. 18 SHIFT SHAFT

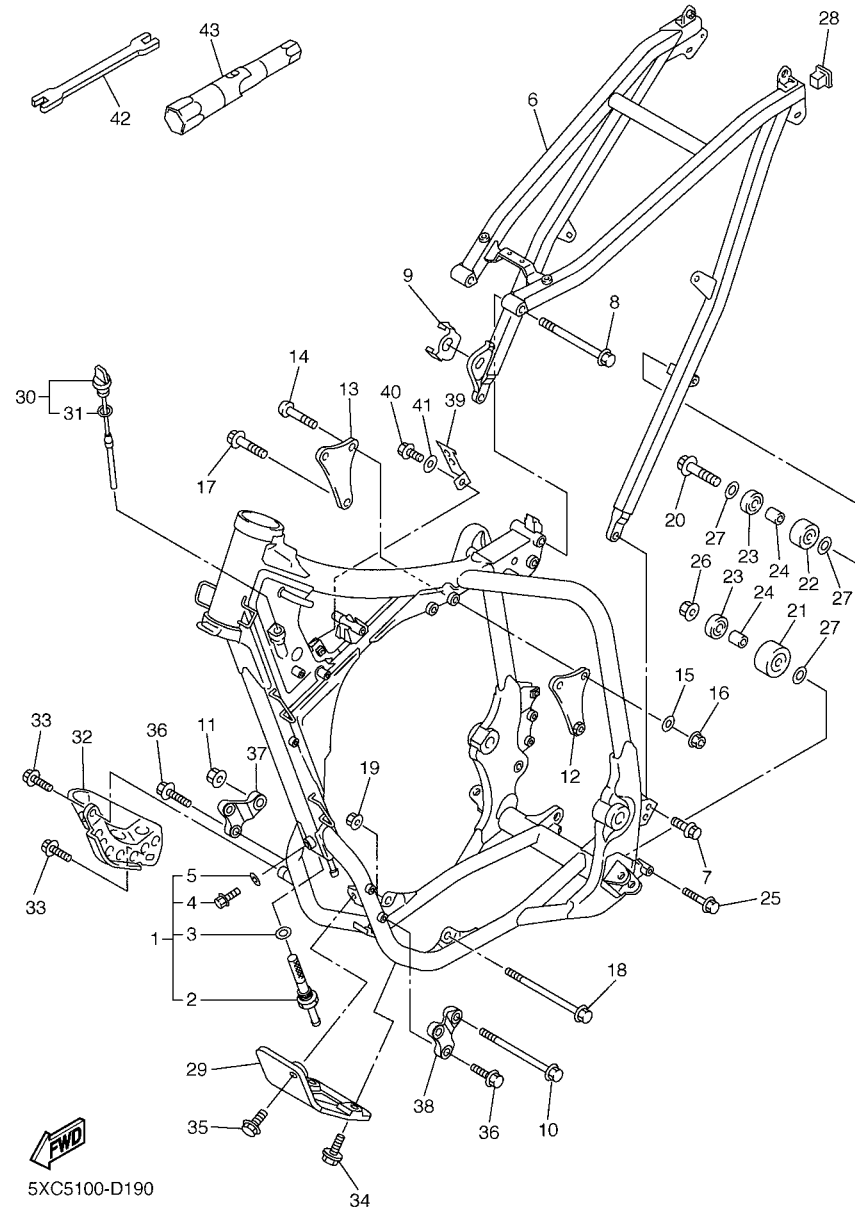

5NL1100-1180

REF. NO.	PART NO.	DESCRIPTION	5XC5	5XC6	5XC7	5XC8	REMARKS
1	4EW-18185-00	SEGMENT	1	1	1	1	
2	3XJ-18173-10	PIN, SHIFT	1	1	1	1	
3	5BE-18172-00	GUIDE, SHIFT	1	1	1	1	
4	90101-06034	BOLT	2	2	2	2	
5	5LP-18122-01	LEVER, SHIFT 2	1	1	1	1	
6	90501-052G5	SPRING, COMPRESSION	2	2	2	2	
7	3XJ-18184-00	PIN, PAWL	2	2	2	2	
8	3XJ-18182-00	PAWL, SHIFTER	2	2	2	2	
9	3XJ-18178-00	ROLLER, SHIFT LEVER	1	1	1	1	
10	5UL-18101-00	SHIFT SHAFT ASSY	1	1	1	1	
11	90387-124F4	COLLAR	1	1	1	1	
12	90508-291A8	SPRING, TORSION	1	1	1	1	
13	93608-33002	PIN, DOWEL	1	1	1	1	
14	93102-12224	OIL SEAL	1	1	1	1	
15	5UL-18110-00	SHIFT PEDAL ASSY	1	1	1	1	
16	95027-06020	BOLT, FLANGE	1	1	1	1	



5XC5100-D190

FIG. 19 FRAME

REF. NO.	PART NO.	DESCRIPTION	5XC5	5XC6	5XC7	5XC8	REMARKS
1	5XC-21101-50	FRONT FRAME COMP.	1	1	1	1	
2	5TA-21756-00	.NET, FILTER	1	1	1	1	
3	90201-145M4	.WASHER, PLATE	1	1	1	1	
4	95827-08012	.BOLT, FLANGE	1	1	1	1	
5	90430-08119	.GASKET	1	1	1	1	
6	5XD-21190-50	REAR FRAME COMP.	1	1	1	1	
7	90105-08057	BOLT, FLANGE	2	2	2	2	
8	90105-08120	BOLT, FLANGE	1	1	1	1	
9	5XD-21455-60	PLATE, PATCH	1	1	1	1	
10	90105-10072	BOLT, FLANGE	1	1	1	1	
11	90179-10658	NUT	1	1	1	1	
12	5NL-21425-00	BRACKET, REAR UPPER 1	1	1	1	1	
13	5NL-21425-10	BRACKET, REAR UPPER 1	1	1	1	1	
14	92017-08055	BOLT, BUTTON HEAD	2	2	2	2	
15	90201-086P8	WASHER, PLATE	4	4	4	4	
16	90179-08674	NUT	2	2	2	2	
17	95817-10050	BOLT, FLANGE	1	1	1	1	
18	90105-10733	BOLT, FLANGE	1	1	1	1	
19	90179-10658	NUT	1	1	1	1	
20	95027-08040	BOLT, FLANGE	1	1	1	1	
21	3JD-22178-20	TENSIONER	1	1	1	1	
22	4EW-22178-01	TENSIONER	1	1	1	1	
23	93300-60804	BEARING	2	2	2	2	
24	90387-086N4	COLLAR	2	2	2	2	
25	95027-08065	BOLT, FLANGE	1	1	1	1	
26	95707-08500	NUT, FLANGE	1	1	1	1	
27	90201-086P8	WASHER, PLATE	3	3	3	3	

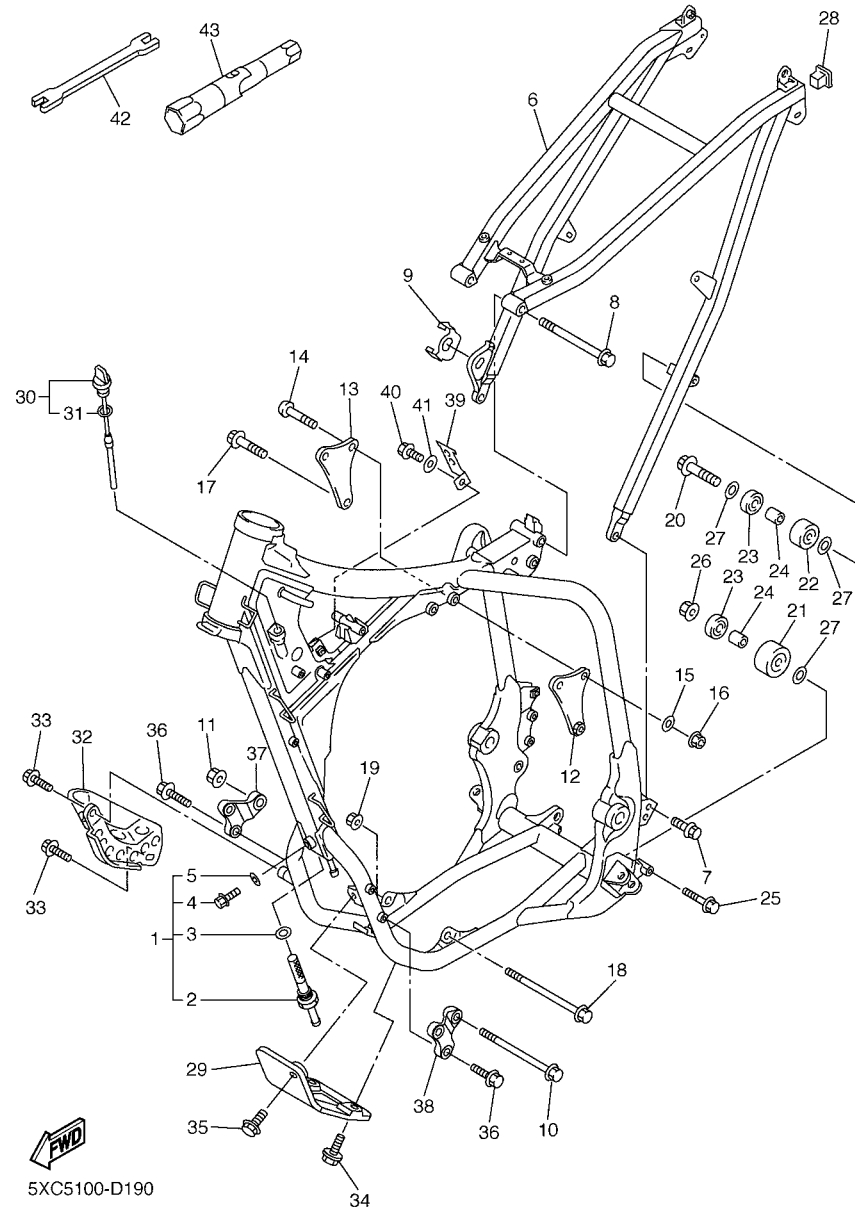

5XC5100-D190

FIG. 19 FRAME

REF. NO.	PART NO.	DESCRIPTION	5XC5	5XC6	5XC7	5XC8	REMARKS
28	90338-18176	PLUG	1	1	1	1	
29	5NL-21471-01	PROTECTOR, ENGINE	1	1	1	1	
30	5UL-15362-01	PLUG, OIL LEVEL	1	1	1	1	
31	93210-08001	.O-RING	1	1	1	1	
32	5NL-2147A-00	GUARD, ENGINE 1	1	1	1	1	
33	95027-08012	BOLT, FLANGE	2	2	2	2	
34	95027-06012	BOLT, FLANGE	2	2	2	2	
35	90119-06001	BOLT, WITH WASHER	1	1	1	1	
36	95817-08016	BOLT, FLANGE	4	4	4	4	
37	5XC-21417-50	BRACKET, FRONT LOWER 1	1	1	1	1	
38	5XC-21417-60	BRACKET, FRONT LOWER 1	1	1	1	1	
39	5TA-21274-01	BRACKET, C.D.I. UNIT	1	1	1	1	
40	97027-06012	BOLT	1	1	1	1	
41	92907-06600	WASHER, PLATE	1	1	1	1	
42	5ET-28166-00	WRENCH, HEXAGON	1	1	1	1	
43	5TA-2814F-00	BOX, SPARK PLUG	1	1	1	1	

FIG. 20 FENDER

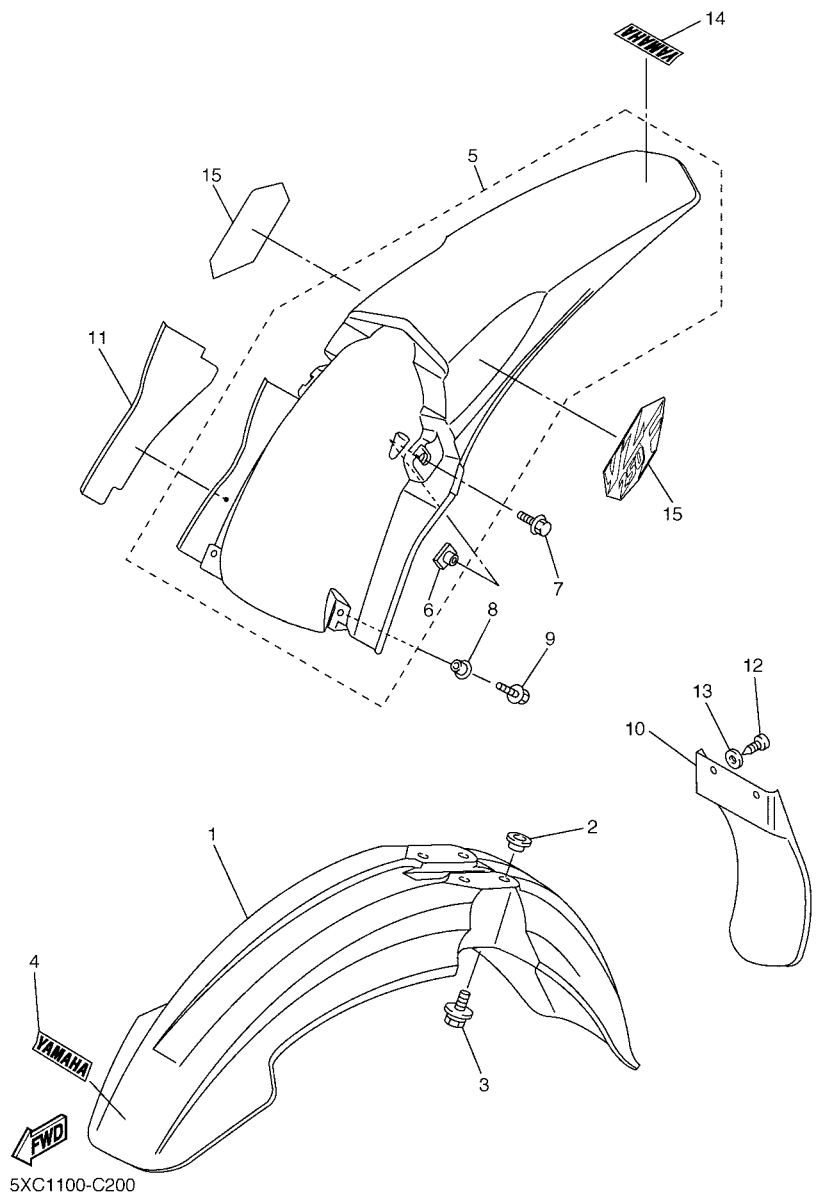

REF. NO.	PART NO.	DESCRIPTION	5XC5	5XC6	5XC7	5XC8	REMARKS
1	5HD-21511-00	FENDER, FRONT	1	1	1	1	
2	90387-06090	COLLAR	4	4	4	4	
3	90119-06096	BOLT, WITH WASHER	4	4	4	4	
4	4ES-2153E-01	EMBLEM, YAMAHA	1	1	1	1	
5	5XD-21610-00	REAR FENDER COMP.	1	1	1	1	
6	5XD-21635-00	.NUT, REAR FENDER	2	2	2	2	
7	90119-06192	BOLT, WITH WASHER	2	2	2	2	
8	90387-06009	COLLAR	2	2	2	2	
9	90119-06225	BOLT, WITH WASHER	2	2	2	2	
10	5TA-21642-00	GUARD, FLAP	1	1	1	1	
11	5TA-2174T-00	INSULATOR, SIDE COVER 2	1	1	1	1	
12	97707-60016	SCREW, TAPPING	2	2	2	2	
13	90201-06557	WASHER, PLATE	2	2	2	2	
14	4ES-2153E-01	EMBLEM, YAMAHA	1	1	1	1	
15	5XC-2163G-00	EMBLEM 1	2	2	2	2	

FIG. 21 SIDE COVER

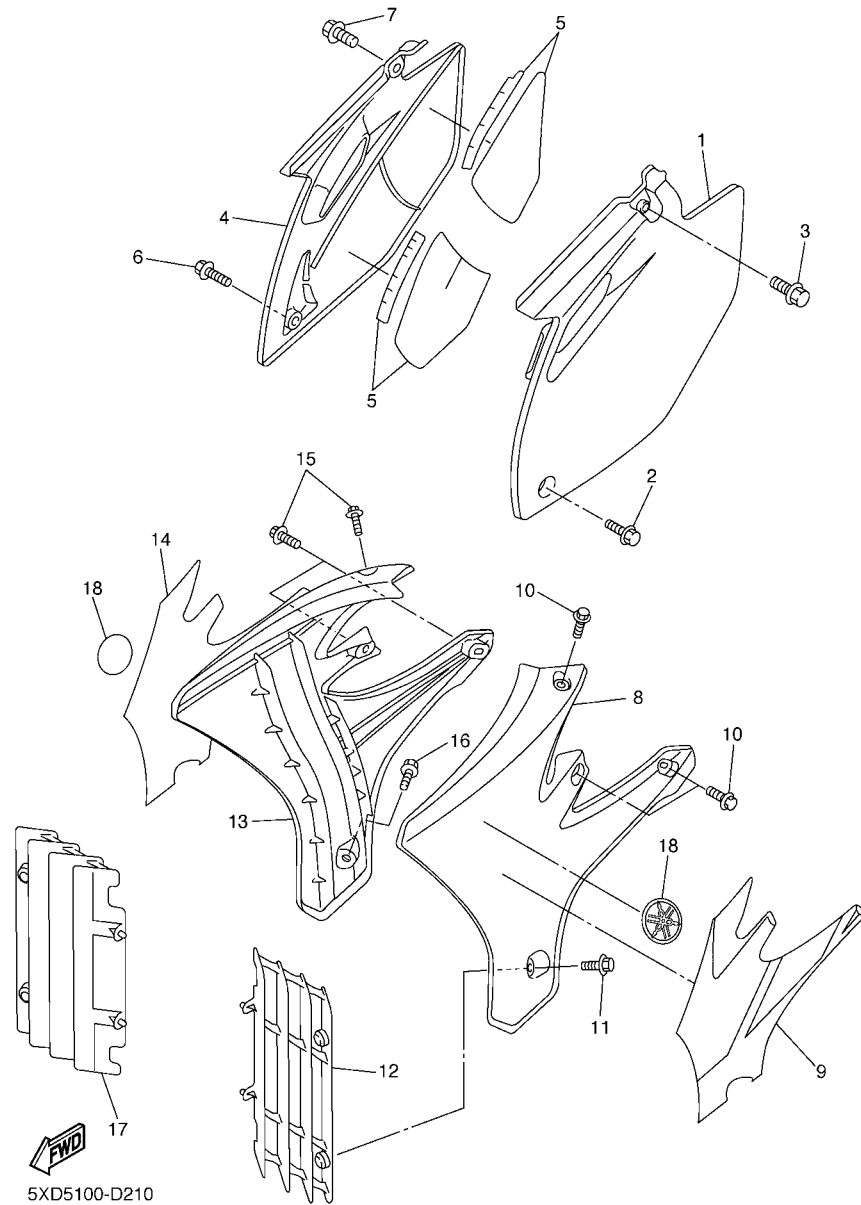

REF. NO.	PART NO.	DESCRIPTION	5XC5	5XC6	5XC7	5XC8	REMARKS
1	5TA-21711-00	COVER, SIDE 1	1	1	1	1	
2	95827-06016	BOLT, FLANGE	1	1	1	1	
3	90119-08238	BOLT, WITH WASHER	1	1	1	1	
4	5TA-21721-00	COVER, SIDE 2	1	1	1	1	
5	5TA-2174A-00	INSULATOR, SIDE COVER	1	1	1	1	
6	95827-06016	BOLT, FLANGE	1	1	1	1	
7	90119-08238	BOLT, WITH WASHER	1	1	1	1	
8	5TA-21730-00	SIDE COVER ASSY 3	1	1	1	1	
9	5XD-2173E-10	GRAPHIC 1	1	1	1	1	
10	90105-06055	BOLT, FLANGE	3	3	3	3	
11	90159-06078	SCREW, WITH WASHER	1	1	1	1	
12	5NL-2172A-11	PANEL 1	1	1	1	1	
13	5TA-21740-00	SIDE COVER ASSY 4	1	1	1	1	
14	5XD-2173F-10	GRAPHIC 2	1	1	1	1	
15	90105-06055	BOLT, FLANGE	3	3	3	3	
16	90159-06078	SCREW, WITH WASHER	1	1	1	1	
17	5NL-2172A-11	PANEL 1	1	1	1	1	
18	5MV-2175C-00	TUNING FORK MARK	2	2	2	2	

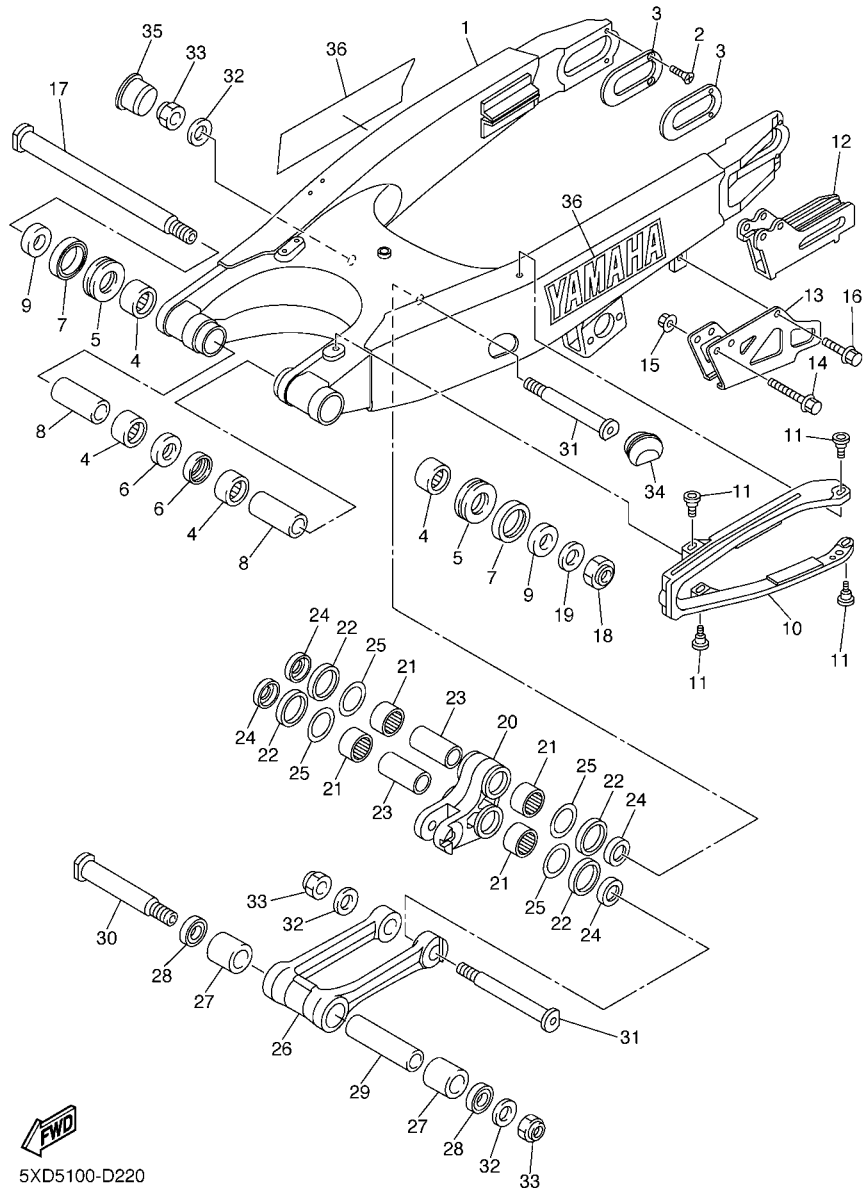

5XD5100-D220

FIG. 22 REAR ARM

REF. NO.	PART NO.	DESCRIPTION	5XC5	5XC6	5XC7	5XC8	REMARKS
1	1C3-22110-00	REAR ARM COMP.	1	1	1	1	
2	90151-04001	SCREW, COUNTERSUNK	4	4	4	4	
3	1C3-22355-00	PATCH	2	2	2	2	
4	93317-22262	BEARING	4	4	4	4	
5	93342-22217	BEARING	2	2	2	2	
6	93106-22019	OIL SEAL (DC 22-28-8)	2	2	2	2	
7	93109-28043	OIL SEAL	2	2	2	2	
8	90387-18004	COLLAR	2	2	2	2	
9	90387-18009	COLLAR	2	2	2	2	
10	1C3-22151-00	SEAL, GUARD	1	1	1	1	
11	1C3-22969-00	SCREW, 1	4	4	4	4	
12	1C3-22199-00	SUPPORT, CHAIN	1	1	1	1	
13	1C3-22128-00	COVER, THRUST 1	1	1	1	1	
14	95027-06050	BOLT, FLANGE	2	2	2	2	
15	90179-06568	NUT	2	2	2	2	
16	95027-06010	BOLT, FLANGE	1	1	1	1	
17	5XD-22141-50	SHAFT, PIVOT	1	1	1	1	
18	90185-16127	NUT, SELF-LOCKING	1	1	1	1	
19	90201-160F6	WASHER, PLATE	1	1	1	1	
20	1C3-2217A-00	ARM, RELAY	1	1	1	1	
21	93315-32166	BEARING	4	4	4	4	
22	93109-25001	OIL SEAL	4	4	4	4	
23	90387-16010	COLLAR	2	2	2	2	
24	90209-16008	WASHER	4	4	4	4	
25	90201-21013	WASHER, PLATE	4	4	4	4	
26	1C3-2217F-00	ROD, CONNECTING 1	1	1	1	1	
27	93315-32165	BEARING	2	2	2	2	

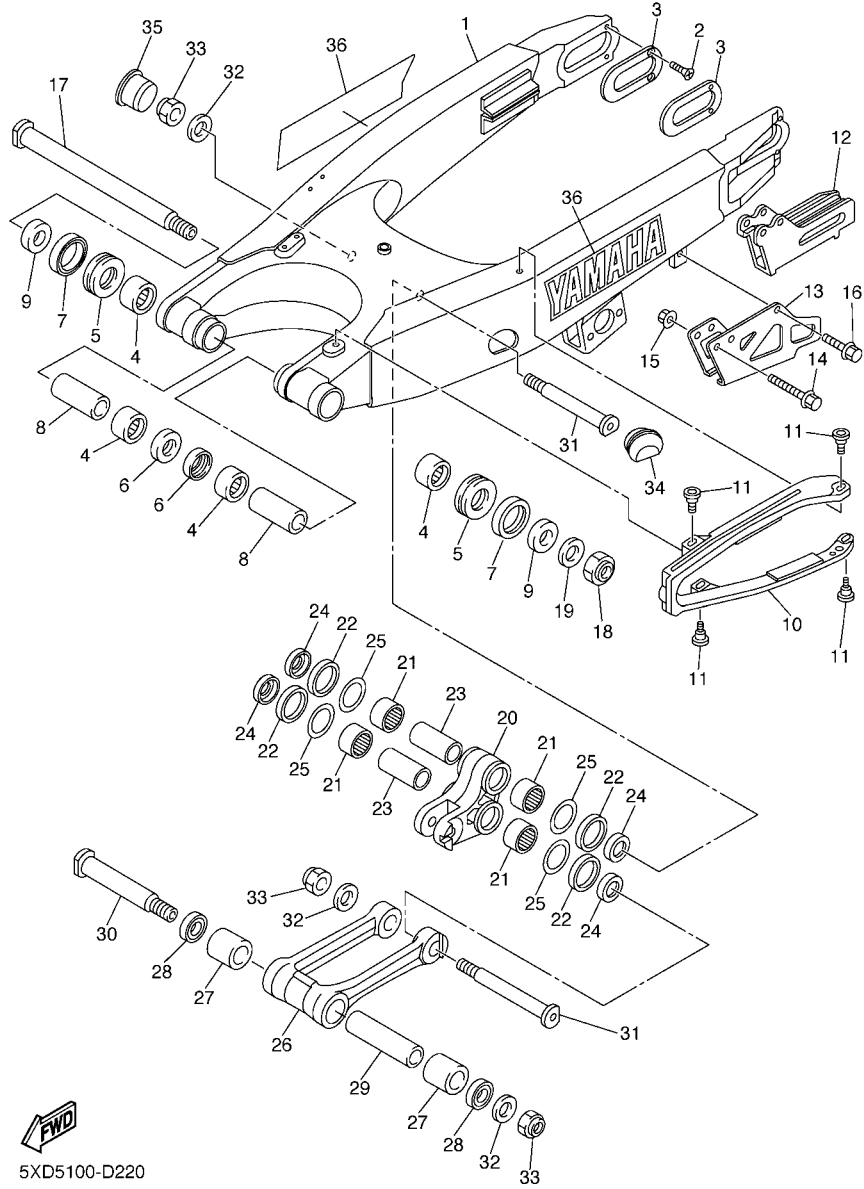

5XD5100-D220

FIG. 22 REAR ARM

REF. NO.	PART NO.	DESCRIPTION	5XC5	5XC6	5XC7	5XC8	REMARKS
28	93109-21001	OIL SEAL	2	2	2	2	
29	90387-14006	COLLAR	1	1	1	1	
30	5XD-22121-50	SHAFT 1	1	1	1	1	
31	1C3-22122-00	SHAFT 2	2	2	2	2	
32	90201-14740	WASHER, PLATE	3	3	3	3	
33	90185-14007	NUT, SELF-LOCKING	3	3	3	3	
34	1C3-2135F-00	COVER	1	1	1	1	
35	1C3-2139R-00	COVER 2	1	1	1	1	
36	5UN-2153A-00	EMBLEM, YAMAHA	2	2	2	2	

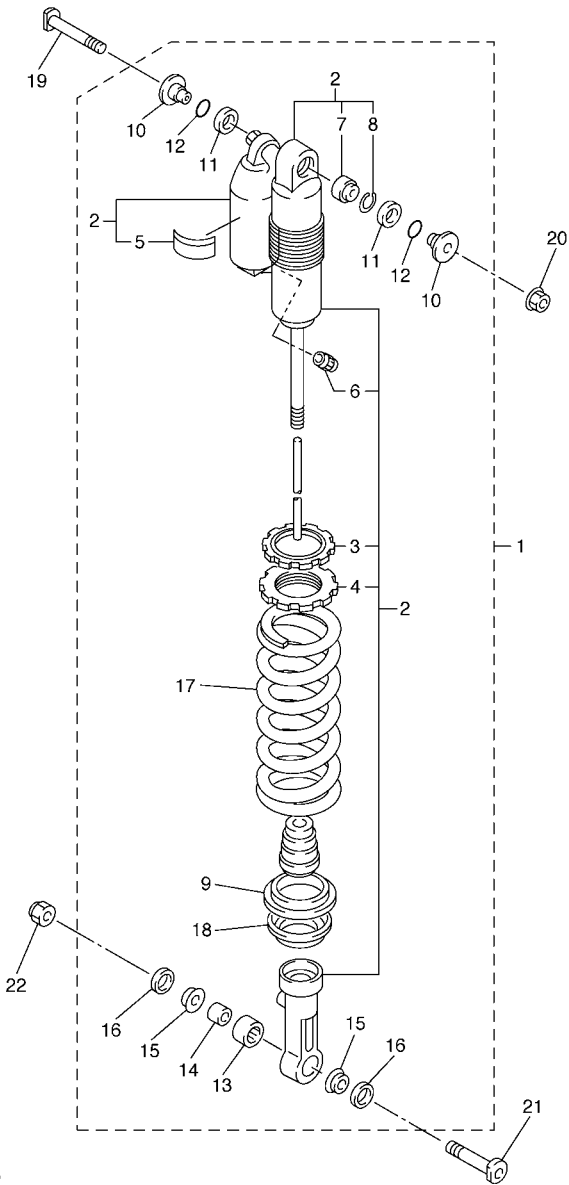

5XD1100-C230

FIG. 23 REAR SUSPENSION

REF. NO.	PART NO.	DESCRIPTION	5XC5	5XC6	5XC7	5XC8	REMARKS
1	5XC-22210-50	SHOCK ABSORBER ASSY, REAR	1				
	5XC-22210-60	SHOCK ABSORBER ASSY, REAR		1			
	5XC-22210-70	SHOCK ABSORBER ASSY, REAR			1		
	5XC-22210-80	SHOCK ABSORBER ASSY, REAR				1	UR FOR CAN
	5XC-22210-90	SHOCK ABSORBER ASSY, REAR				1	UR FOR OCE,ZAF
2	5XC-22201-50	.DAMPER SUB ASSY	1				
	5XC-22201-60	.DAMPER SUB ASSY		1			
	5XC-22201-70	.DAMPER SUB ASSY			1		
	5XC-22201-80	.DAMPER SUB ASSY				1	UR FOR CAN
	5XC-22201-90	.DAMPER SUB ASSY				1	UR FOR OCE,ZAF
3	3SP-22234-00	..GUIDE, SPRING 3	1	1	1	1	
4	3SP-22213-00	..SEAT, SPRING UPPER	1	1	1	1	
5	4AA-22259-80	..LABEL, WARNING	1				
	4AA-22259-40	..LABEL, WARNING		1		1	UR FOR OCE,ZAF
	4AA-22259-50	..LABEL, WARNING			1		
	4AA-22259-60	..LABEL, WARNING				1	UR FOR CAN
6	509-23184-L0	..CAP, AIR VALVE	1	1	1	1	
7	4JX-22226-00	..BUSH, SHOCK ABSORBER LOWER	1	1	1	1	
8	5DH-23183-00	..CIRCLIP	1	1	1	1	
9	5MV-22224-00	.GUIDE, SPRING 2	1	1	1	1	
10	1C3-22253-00	.COLLAR, DISTANCE	2	2	2	2	
11	3JE-22475-00	.SEAL, DUST	2	2	2	2	
12	4EW-22474-00	.SEAL, RING	2	2	2	2	
13	5UN-22176-00	.BEARING	1	1	1	1	
14	5MV-22184-00	.BUSH	1	1	1	1	
15	5MV-22253-00	.COLLAR, DISTANCE	2	2	2	2	
16	5NY-22475-00	.SEAL, DUST	2	2	2	2	

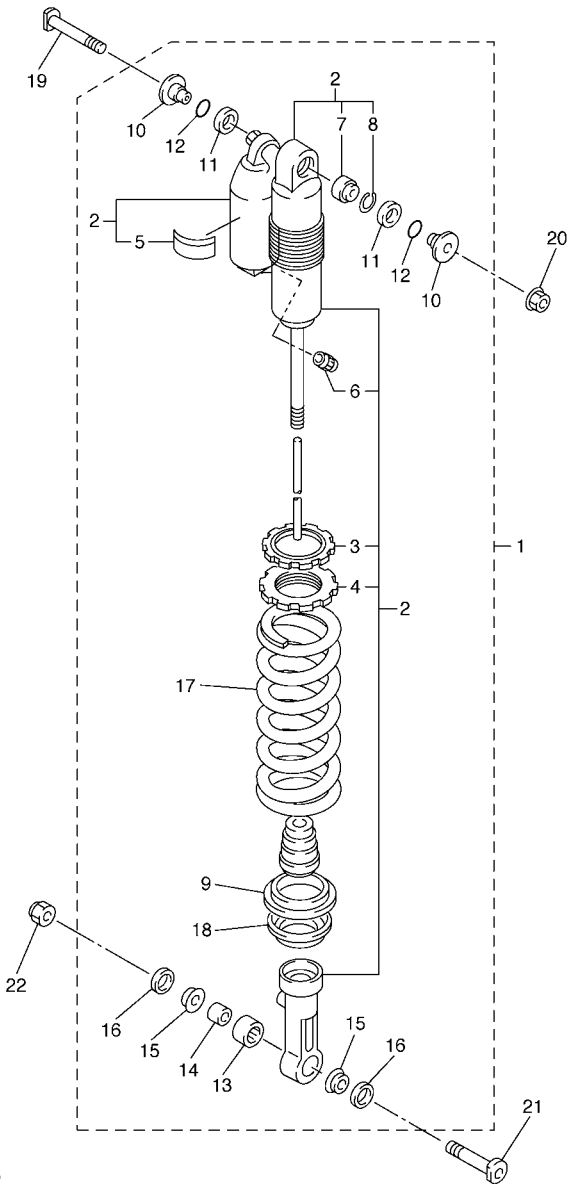

FWD
5XD1100-C230

FIG. 23 REAR SUSPENSION

REF. NO.	PART NO.	DESCRIPTION	5XC5	5XC6	5XC7	5XC8	REMARKS
17	5UN-22212-30	.SPRING (K=48N/MM)	1	1	1	1	
18	5XE-22214-00	.GUIDE, SPRING 1	1	1	1	1	
19	5XE-22242-00	BOLT 2	1	1	1	1	
20	95607-10200	NUT, U FLANGE	1	1	1	1	
21	5NY-22241-00	BOLT 1	1	1	1	1	
22	90185-10060	NUT, SELF-LOCKING	1	1	1	1	

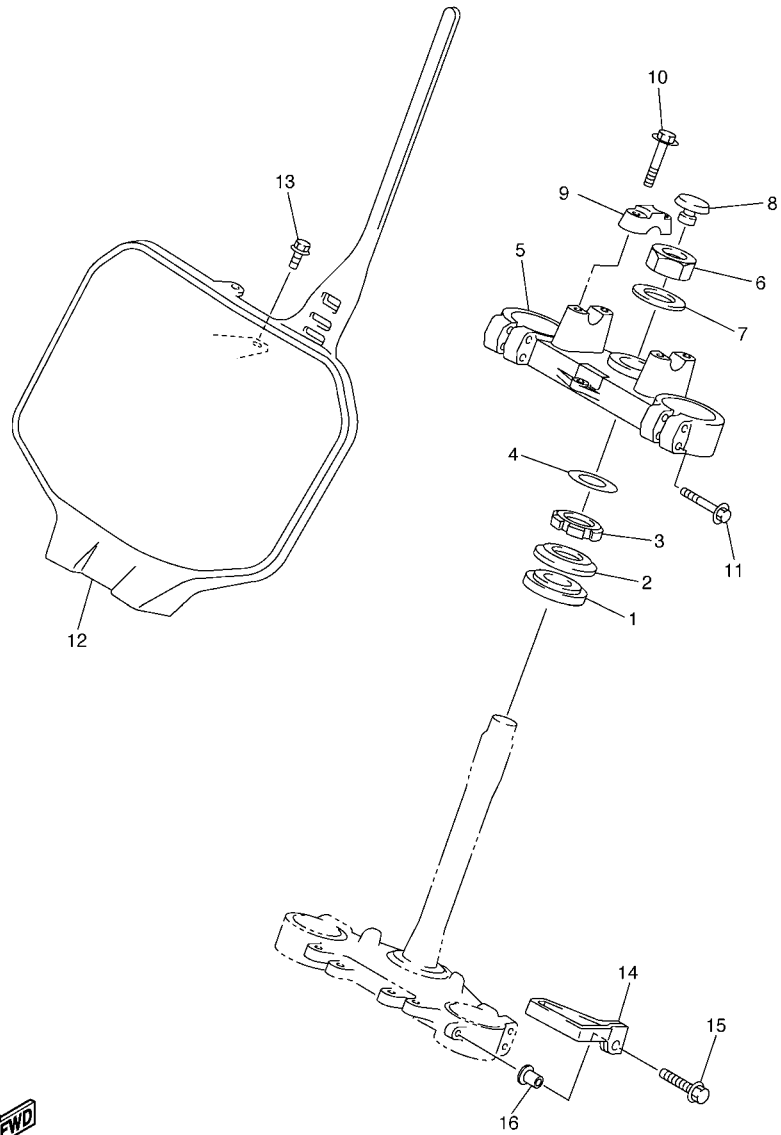

FIG. 24 STEERING

REF. NO.	PART NO.	DESCRIPTION	5XC5	5XC6	5XC7	5XC8	REMARKS
1	93332-00068	BEARING	1	1	1	1	
2	4EW-23416-00	COVER, BALL RACE 2	1	1	1	1	
3	90179-28003	NUT	1	1	1	1	
4	90201-286K9	WASHER, PLATE	1	1	1	1	
5	5XE-23435-20	CROWN, HANDLE	1	1	1	1	
6	5TA-23357-00	NUT	1	1	1	1	
7	90201-247L2	WASHER, PLATE	1	1	1	1	
8	5TJ-2319U-00	CAP	1	1	1	1	
9	5XE-23441-00	HOLDER, HANDLE UPPER	2	2	2	2	
10	95027-08035	BOLT, FLANGE	4	4	4	4	
11	95027-08040	BOLT, FLANGE	4	4	4	4	
12	1C3-23485-10	PLATE, NUMBER	1	1	1	1	
13	90119-06225	BOLT, WITH WASHER	1	1	1	1	
14	5XE-23389-00	GUIDE, CABLE	1	1	1	1	
15	95027-06020	BOLT, FLANGE	1	1	1	1	
16	5XE-23113-00	COLLAR	1	1	1	1	



5XD5100-D240

D9

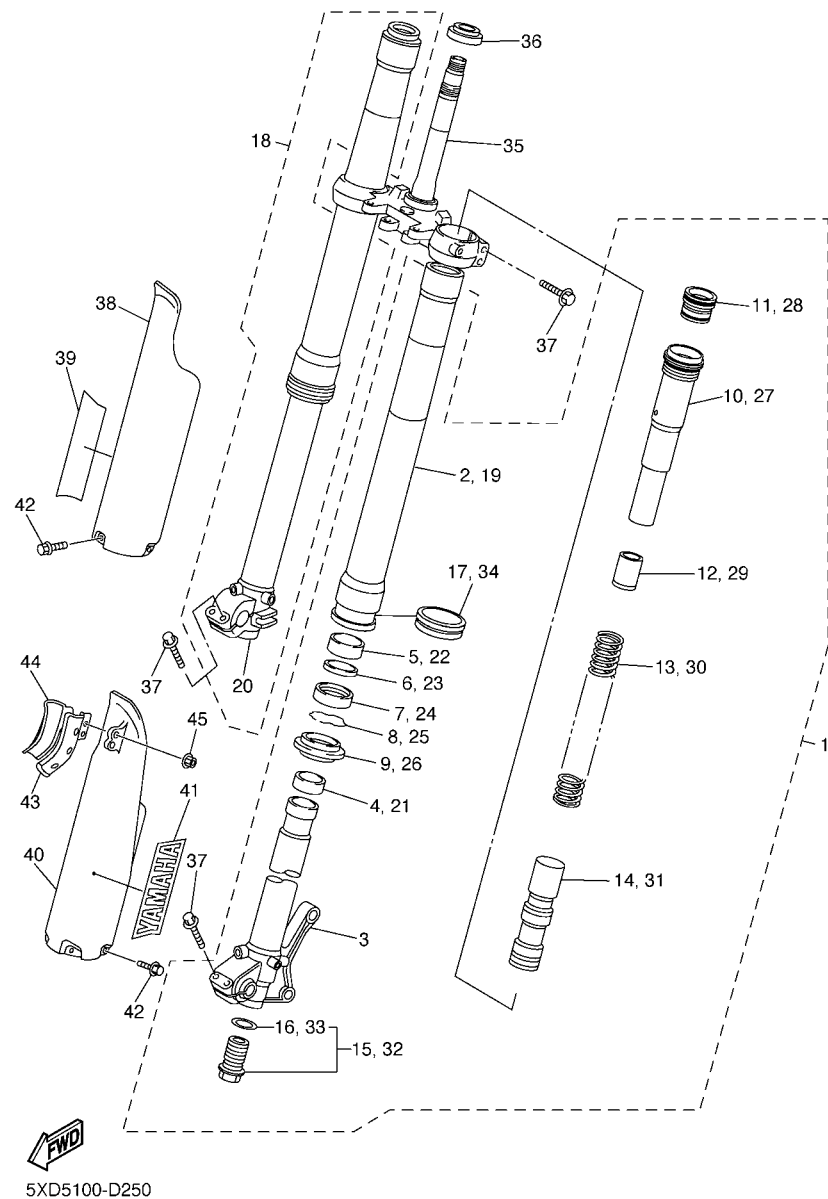
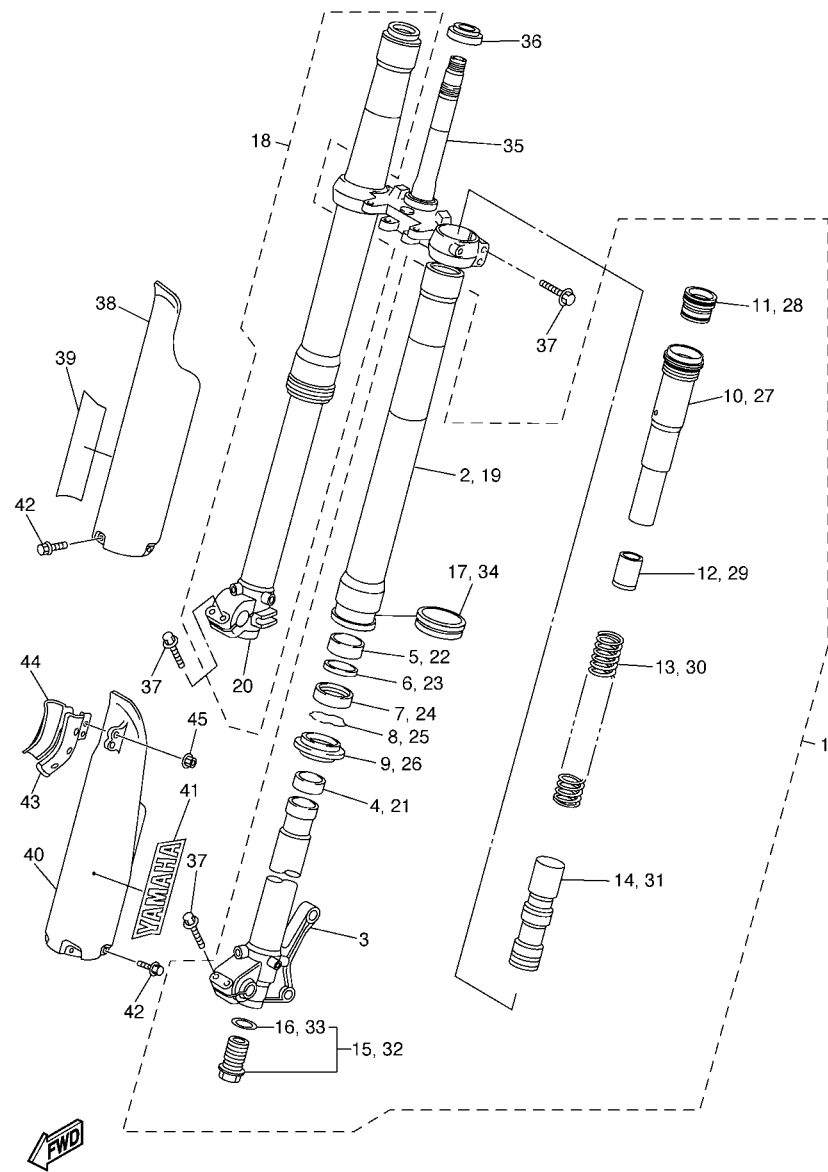

FIG. 25 FRONT FORK

REF. NO.	PART NO.	DESCRIPTION	5XC5	5XC6	5XC7	5XC8	REMARKS
1	5XC-23102-50	FRONT FORK ASSY (L.H)	1			1	
	5XC-23102-60	FRONT FORK ASSY (L.H)		1	1		
2	1C3-23136-L0	.TUBE, OUTER	1	1	1	1	
3	1P8-23120-L0	.INNER TUBE COMP.2	1	1	1	1	
4	5XE-23171-L0	.PISTON, FRONT FORK	1	1	1	1	
5	5XE-23125-L0	.METAL, SLIDE 1	1	1	1	1	
6	5XE-23146-L0	.WASHER, OIL SEAL	1	1	1	1	
7	1C3-23145-L0	.OIL SEAL	1	1	1	1	
8	5XE-23153-L0	.RING, SNAP	1	1	1	1	
9	5XE-23144-L0	.SEAL, DUST	1	1	1	1	
10	1C3-23170-M0	.CYLINDER COMP., FRONT FORK	1			1	
	1C3-23170-L0	.CYLINDER COMP., FRONT FORK		1	1		
11	5XC-2316A-N0	.VALVE COMP.	1			1	
	5XC-2316A-P0	.VALVE COMP.		1	1		
12	1C3-23118-L0	.SPACER	1	1	1	1	
13	1P8-23141-L0	.SPRING, FRONT FORK(K=4.3N/MM)	1	1	1	1	
14	1C3-2316E-L0	.SPACER	1	1	1	1	
15	1C3-23111-L0	.BOLT, CAP	1	1	1	1	
16	2HH-23158-L0	.GASKET	1	1	1	1	
17	1C3-2314F-L0	.PROTECTOR GUIDE COMP., 1	1	1	1	1	
18	5XC-23103-50	FRONT FORK ASSY (R.H)	1			1	
	5XC-23103-60	FRONT FORK ASSY (R.H)		1	1		
19	1C3-23136-L0	.TUBE, OUTER	1	1	1	1	
20	1P8-23110-L0	.INNER TUBE COMP.1	1	1	1	1	
21	5XE-23171-L0	.PISTON, FRONT FORK	1	1	1	1	
22	5XE-23125-L0	.METAL, SLIDE 1	1	1	1	1	
23	5XE-23146-L0	.WASHER, OIL SEAL	1	1	1	1	



5XD5100-D250

FIG. 25 FRONT FORK

REF. NO.	PART NO.	DESCRIPTION	5XC5	5XC6	5XC7	5XC8	REMARKS
24	1C3-23145-L0	.OIL SEAL	1	1	1	1	
25	5XE-23153-L0	.RING, SNAP	1	1	1	1	
26	5XE-23144-L0	.SEAL, DUST	1	1	1	1	
27	1C3-23170-M0	.CYLINDER COMP., FRONT FORK	1			1	
	1C3-23170-L0	.CYLINDER COMP., FRONT FORK		1	1		
28	5XC-2316A-N0	.VALVE COMP.	1			1	
	5XC-2316A-P0	.VALVE COMP.		1	1		
29	1C3-23118-L0	.SPACER	1	1	1	1	
30	1P8-23141-L0	.SPRING, FRONT FORK(K=4.3N/MM)	1	1	1	1	
31	1C3-2316E-L0	.SPACER	1	1	1	1	
32	1C3-23111-L0	.BOLT, CAP	1	1	1	1	
33	2HH-23158-L0	..GASKET	1	1	1	1	
34	1C3-2314F-L0	.PROTECTOR GUIDE COMP., 1	1	1	1	1	
35	5XC-23340-M0	UNDER BRACKET COMP.	1	1	1	1	
36	93332-00081	BEARING	1	1	1	1	
37	5NY-23346-L0	BOLT 1	8	8	8	8	
38	1C3-2315J-00	PROTECTOR 2	1	1	1	1	
39	4XL-2153A-10	EMBLEM, YAMAHA	1	1	1	1	
40	1C3-2315H-00	PROTECTOR 1	1	1	1	1	
41	4XL-2153A-10	EMBLEM, YAMAHA	1	1	1	1	
42	3SP-23356-L0	BOLT 2	6	6	6	6	
43	1C3-23466-00	CLAMP	1	1	1	1	
44	1C3-23467-00	CLAMP	1	1	1	1	
45	95707-06500	NUT, FLANGE	2	2	2	2	

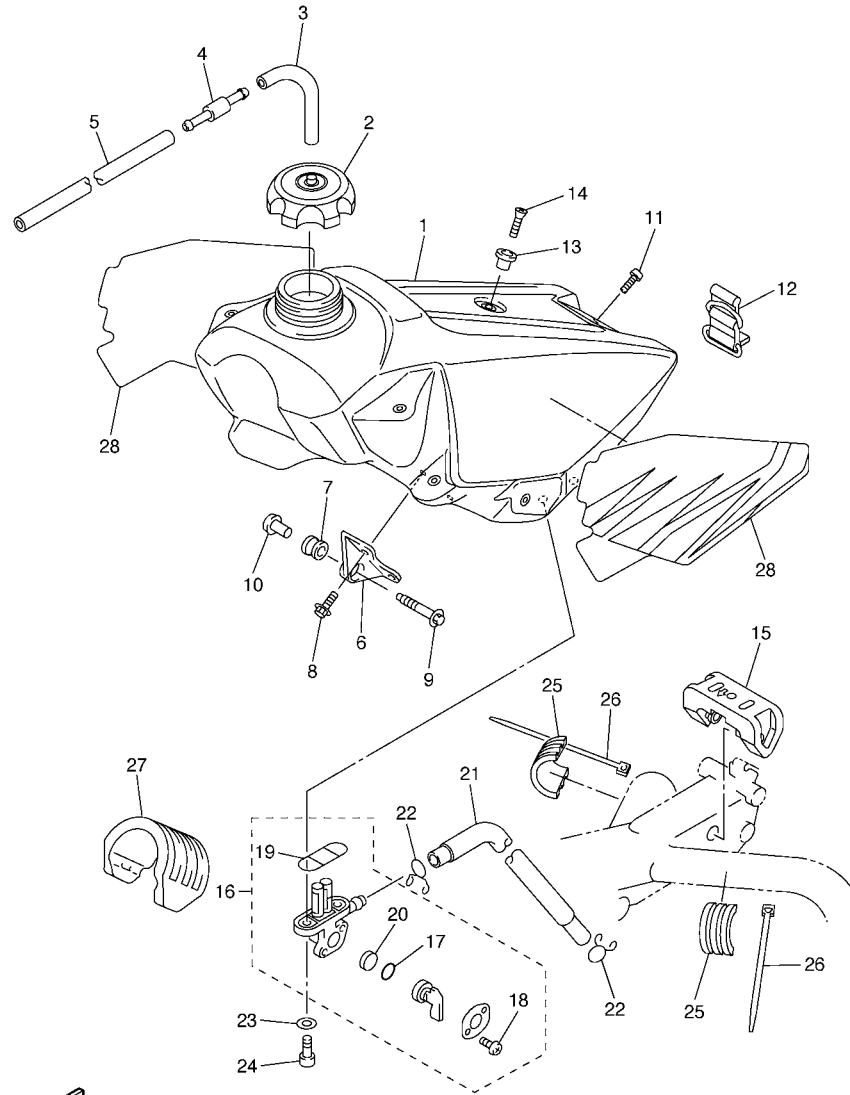

5XD5100-D260

FIG. 26 FUEL TANK

REF. NO.	PART NO.	DESCRIPTION	5XC5	5XC6	5XC7	5XC8	REMARKS
1	5XD-24110-01	FUEL TANK COMP.	1	1	1	1	
2	5NY-24610-00	CAP ASSY	1	1	1	1	
3	90445-09220	HOSE (L30)	1	1	1	1	
4	3XJ-24380-00	PIPE JOINT ASSY	1	1	1	1	
5	90445-09095	HOSE (L215)	1	1	1	1	
6	5XE-24144-00	HOLDER, DAMPER	2	2	2	2	
7	90480-18549	GROMMET	2	2	2	2	
8	95027-06016	BOLT, FLANGE	4	4	4	4	
9	5XE-24176-00	BOLT 1	2	2	2	2	
10	5NY-24186-00	WASHER, SPECIAL	2	2	2	2	
11	98907-06025	SCREW, BIND	1	1	1	1	
12	5SF-24173-00	BAND, TANK FITTING 1	1	1	1	1	
13	4EW-2412F-00	BRACKET, SEAT	1	1	1	1	
14	98707-06025	SCREW, FLAT HEAD	1	1	1	1	
15	4SS-24181-00	DAMPER, LOCATING 1	1	1	1	1	
16	4DP-24500-01	FUEL COCK ASSY 1	1	1	1	1	
17	3AJ-24534-01	.SEAL, COCK	1	1	1	1	
18	98507-03008	.SCREW, PAN HEAD	2	2	2	2	
19	4X8-24512-00	.O-RING	1	1	1	1	
20	3AC-24523-00	.VALVE PACKING	1	1	1	1	
21	90445-11185	HOSE	1	1	1	1	
22	90467-10008	CLIP	2	2	2	2	
23	90202-05193	WASHER, PLATE	2	2	2	2	
24	90149-06011	SCREW	2	2	2	2	
25	5NY-24183-00	DAMPER, LOCATING 3	2	2	2	2	
26	90465-13152	CLAMP	2	2	2	2	
27	5BE-24182-00	DAMPER, LOCATING 2	1	1	1	1	

FIG. 26 FUEL TANK

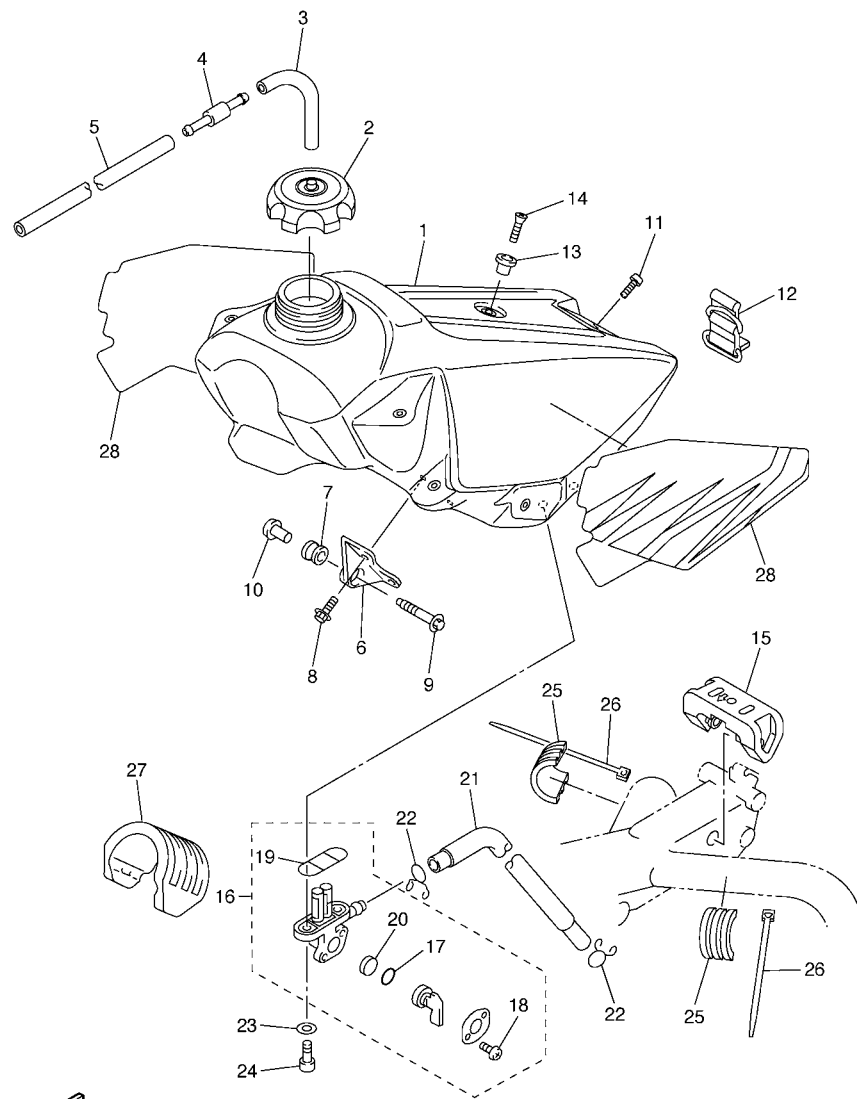

5XD5100-D260

REF. NO.	PART NO.	DESCRIPTION	5XC5	5XC6	5XC7	5XC8	REMARKS
28	5XD-24240-10	GRAPHIC SET	1	1	1	1	

FIG. 27 SEAT

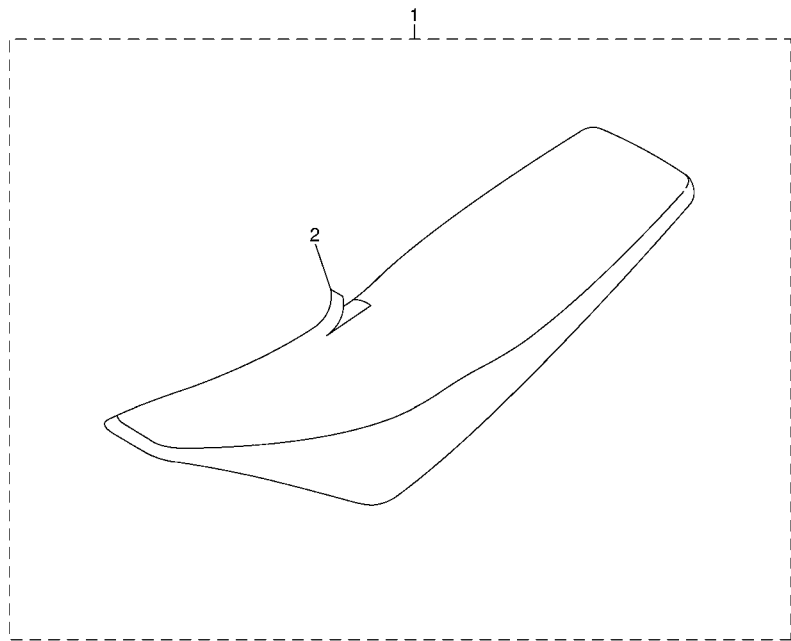

REF. NO.	PART NO.	DESCRIPTION	5XC5	5XC6	5XC7	5XC8	REMARKS
1	5XD-24710-00	SINGLE SEAT ASSY	1	1	1	1	
2	5XD-2470F-00	.SEAT COVER COMP.	1	1	1	1	



5XD1100-C270

FIG. 28 FRONT WHEEL

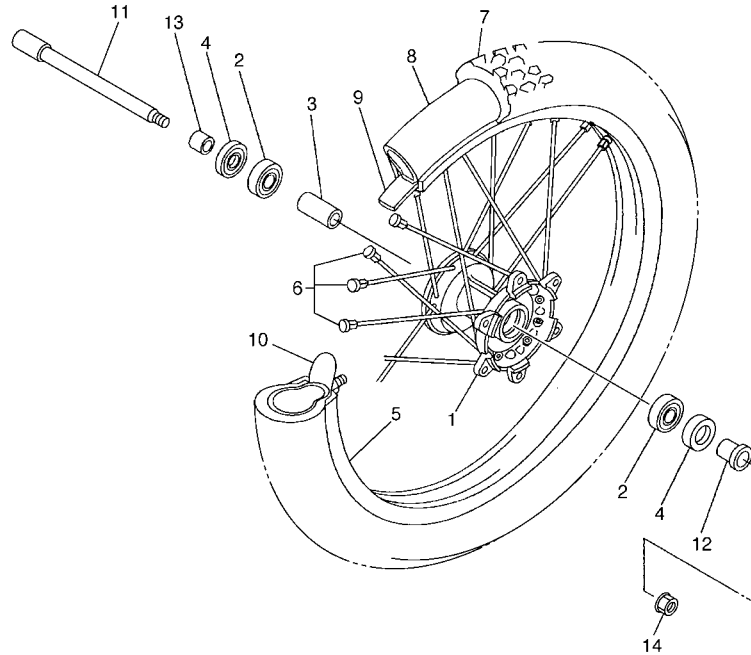

REF. NO.	PART NO.	DESCRIPTION	5XC5	5XC6	5XC7	5XC8	REMARKS
1	5NY-25111-00	HUB, FRONT	1	1	1	1	
2	93306-90403	BEARING	2	2	2	2	
3	5NY-25117-00	SPACER, BEARING	1	1	1	1	
4	93102-26468	OIL SEAL	2	2	2	2	
5	94416-21005	RIM (1.60-21)	1	1	1	1	
6	5NY-25104-00	SPOKE SET, FRONT	1	1	1	1	
7	94108-21015	TIRE (80/100-21 51M D739FA)	1			1	DUNLOP
	94108-2112Y	TIRE (80/100-21 51M D755F)		1		1	DUNLOP (FRA,CAN)
	*	TIRE (80/100-21 51R MT320)		1			LM PIRELLI
	94108-21012	TIRE(80/100-21 51M M601)			1		BRIDGESTONE
8	94227-21101	TUBE (80/100-21 M/C TR4)	1	1		1	DUNLOP FOR FRA
	*	TUBE (80/100-21)		1			LM PIRELLI
	94209-21229	TUBE (80/100-21 M/C TR4)			1		BRIDGESTONE
9	94309-21161	BAND, RIM (1.60-21)	1	1		1	DUNLOP FOR FRA
	*	BAND, RIM (80/100-21)		1			LM PIRELLI
	94330-21084	BAND,RIM (1.60-21)			1		BRIDGESTONE
10	5SF-25394-00	SPACER, BEAD	1	1	1	1	
11	1C3-25181-00	AXLE, WHEEL	1	1	1	1	
12	5NY-25183-00	COLLAR, WHEEL	1	1	1	1	
13	5NY-25186-00	COLLAR, WHEEL	1	1	1	1	
14	90179-16002	NUT	1	1	1	1	



5XD5100-D280

FIG. 29 FRONT BRAKE CALIPER

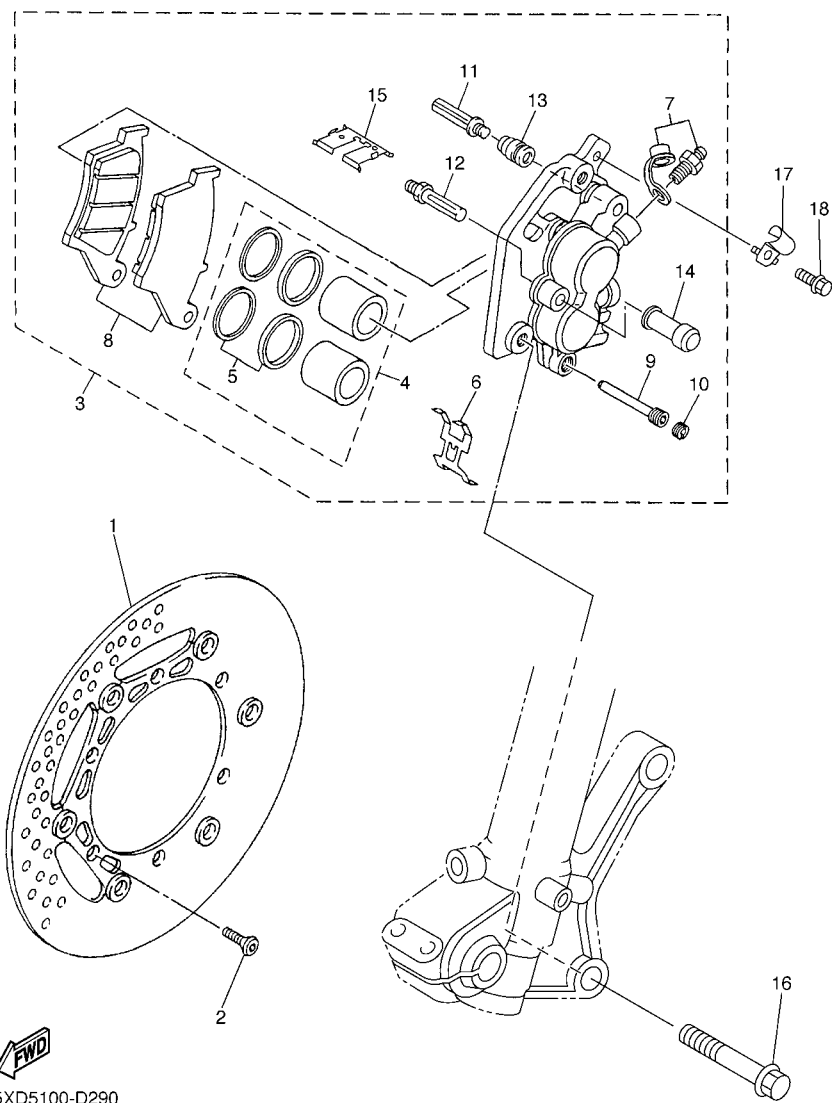

5XD5100-D290

REF. NO.	PART NO.	DESCRIPTION	5XC5	5XC6	5XC7	5XC8	REMARKS
1	5MV-2581T-00	DISK BRAKE ASSY	1	1	1	1	
2	90149-06327	SCREW	6	6	6	6	
3	1C3-2580T-00	CALIPER ASSY (LEFT)	1	1	1	1	
4	5UN-W0057-00	.PISTON ASSY, CALIPER	1	1	1	1	
5	3JD-W0047-00	..CALIPER SEAL KIT	1	1	1	1	
6	5DH-25919-00	.SUPPORT, PAD	1	1	1	1	
7	1UY-W0048-50	.BLEED SCREW KIT	1	1	1	1	
8	5MV-W0045-01	.BRAKE PAD KIT	1	1	1	1	
9	5DH-25933-00	.PIN, PAD	1	1	1	1	
10	5DH-25916-00	.PLUG	1	1	1	1	
11	3SP-25926-51	.BOLT	1	1	1	1	
12	3SP-25914-51	.PIN, SLIDE	1	1	1	1	
13	3JD-25917-00	.BOOT, CALIPER	1	1	1	1	
14	1UY-25937-51	.BOOT 2	1	1	1	1	
15	5DH-25849-00	.RETAINER, CALIPER	1	1	1	1	
16	90105-08659	BOLT, FLANGE	2	2	2	2	
17	1C3-25875-00	HOLDER, BRAKE HOSE 1	1	1	1	1	
18	95027-06010	BOLT, FLANGE	1	1	1	1	

FIG. 30 REAR WHEEL

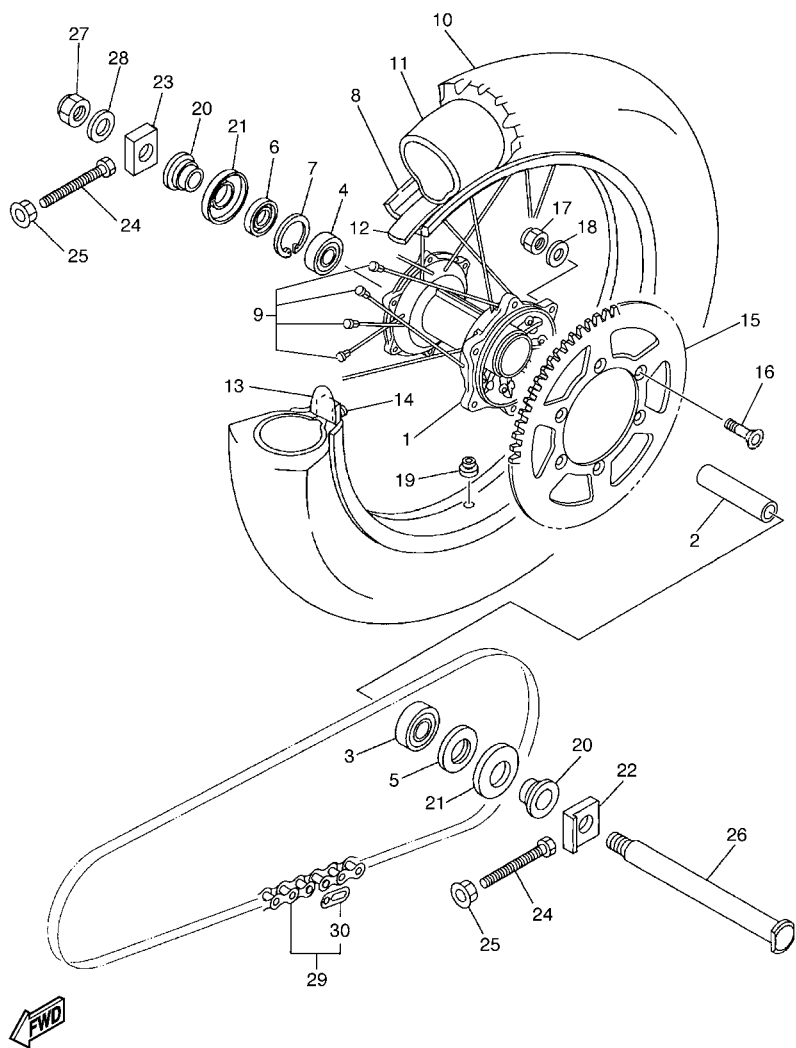

FWD
5XD5100-D300

REF. NO.	PART NO.	DESCRIPTION	5XC5	5XC6	5XC7	5XC8	REMARKS
1	5ET-25311-00	HUB, REAR	1	1	1	1	
2	5ET-25317-00	SPACER, BEARING	1	1	1	1	
3	93306-27205	BEARING	1	1	1	1	
4	93306-07202	BEARING	1	1	1	1	
5	93106-30044	OIL SEAL	1	1	1	1	
6	93106-30045	OIL SEAL	1	1	1	1	
7	99009-45500	CIRCLIP	1	1	1	1	
8	94418-19003	RIM (1.85-19)	1	1	1	1	
9	5HD-25304-00	SPOKE SET, REAR	1	1	1	1	
10	94110-19011	TIRE (100/90-19 57M D739)	1			1	DUNLOP
	94110-1913B	TIRE (100/90-19 57M D755)		1		1	DUNLOP (FRA,CAN)
	*	TIRE (100/90-19 MT320)		1			LM PIRELLI
	94110-19009	TIRE(100/90-19 51M M602)			1		BRIDGESTONE
11	94210-19224	TUBE (100/90-19 M/C TR4 BTL)	1	1		1	DUNLOP FOR FRA
	*	TUBE (110/90-19)		1			LM PIRELLI
	94210-19222	TUBE (100/90-19 M/C TR4)			1		BRIDGESTONE
12	94321-19135	BAND, RIM (1.85-19)	1	1		1	DUNLOP FOR FRA
	*	BAND, RIM (3.50-18)		1			LM METZELER
	94316-19156	BAND, RIM (1.85-19)			1		BRIDGESTONE
13	4XM-25394-00	SPACER, BEAD	1	1	1	1	
14	4XM-25364-00	DAMPÉR	1	1	1	1	
15	1C3-25448-00	SPROCKET, DRIVEN (48T)	1			1	STD
	1C3-25449-00	SPROCKET, DRIVEN (49T)		1	1		STD
	1C3-25447-00	SPROCKET, DRIVEN (47T)	1	1	1	1	AP
	1C3-25448-00	SPROCKET, DRIVEN (48T)		1	1		AP
	1C3-25449-00	SPROCKET, DRIVEN (49T)	1			1	AP
	1C3-25450-00	SPROCKET, DRIVEN (50T)	1	1	1	1	AP

FIG. 30 REAR WHEEL

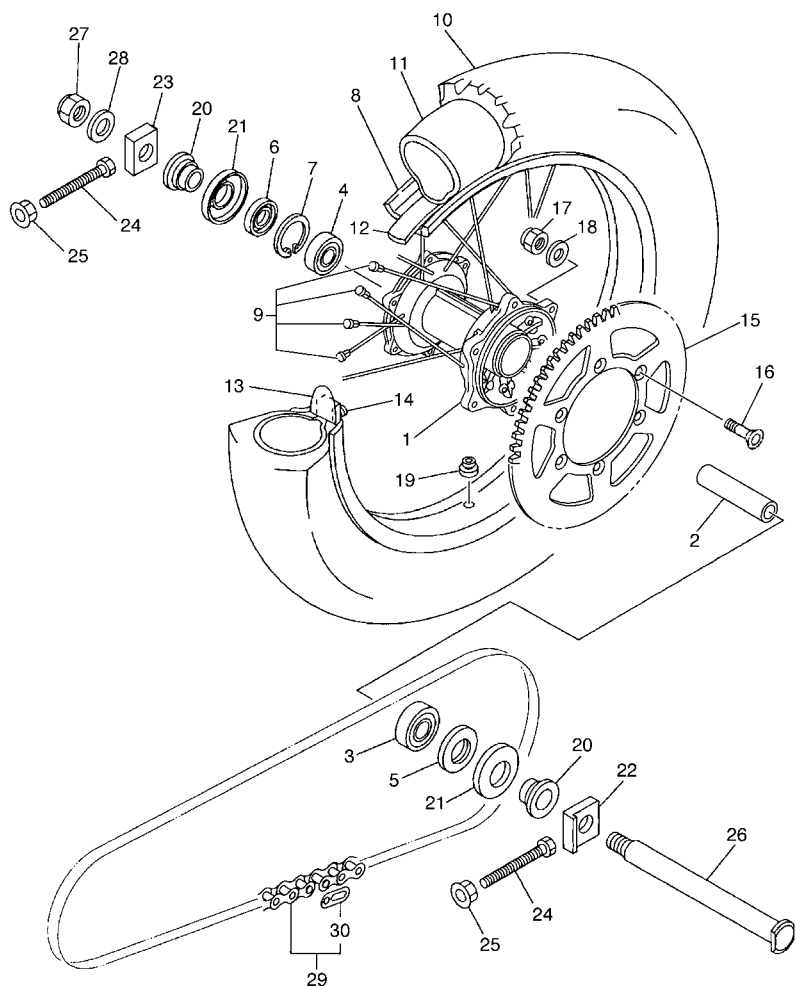

5XD5100-D300

REF. NO.	PART NO.	DESCRIPTION	5XC5	5XC6	5XC7	5XC8	REMARKS
15	1C3-25451-00	SPROCKET, DRIVEN (51T)	1	1	1	1	AP
	1C3-25452-00	SPROCKET, DRIVEN (52T)	1	1	1	1	AP
16	90109-081G1	BOLT	6	6	6	6	
17	90185-08169	NUT, SELF-LOCKING	6	6	6	6	
18	90201-08326	WASHER, PLATE	6	6	6	6	
19	90480-08608	GROMMET	1	1	1	1	
20	5UN-25383-00	COLLAR, WHEEL	2	2	2	2	
21	5ET-25367-00	COVER, HUB DUST	2	2	2	2	
22	1C3-25388-00	PULLER, CHAIN 1	1	1	1	1	
23	1C3-25389-00	PULLER, CHAIN 2	1	1	1	1	
24	90101-08777	BOLT	2	2	2	2	
25	90179-08299	NUT	2	2	2	2	
26	1C3-25381-00	AXLE, WHEEL	1	1	1	1	
27	90185-20168	NUT, SELF-LOCKING	1	1	1	1	
28	90201-203U1	WASHER, PLATE	1	1	1	1	
29	9Y581-92111	CHAIN (DID 520D 112L)	1	1	1	1	
30	94681-68001	.JOINT,CHAIN (DID 520DM-RJ)	1	1	1	1	

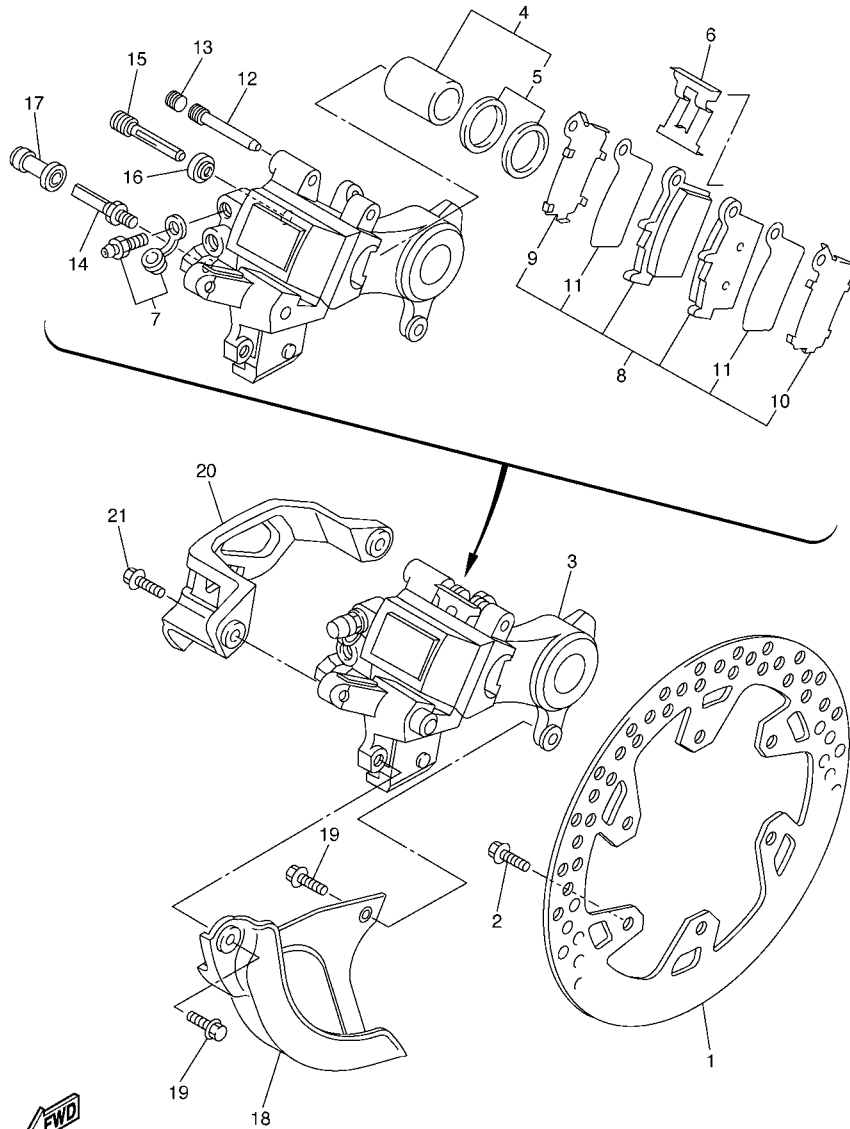

5XD5100-D310

FIG. 31 REAR BRAKE CALIPER

REF. NO.	PART NO.	DESCRIPTION	5XC5	5XC6	5XC7	5XC8	REMARKS
1	5NY-2582W-00	DISK, REAR BRAKE 2	1	1	1	1	
2	90109-065G4	BOLT	6	6	6	6	
3	1C3-2580W-10	CALIPER ASSY, REAR 2	1	1	1	1	
4	5UN-W0057-50	.PISTON ASSY, CALIPER	1	1	1	1	
5	5UN-W0047-50	..CALIPER SEAL KIT	1	1	1	1	
6	5DH-25919-50	..SUPPORT, PAD	1	1	1	1	
7	1UY-W0048-50	.BLEED SCREW KIT	1	1	1	1	
8	1C3-W0046-10	.BRAKE PAD KIT 2	1	1	1	1	
9	5UN-25828-60	..SHIM, CALIPER	1	1	1	1	
10	5UN-25827-60	..SHIM, CALIPER	1	1	1	1	
11	5UN-22898-60	..INSULATOR, HEAT	2	2	2	2	
12	8CR-25924-00	.PIN, PAD	1	1	1	1	
13	5DH-25916-00	.PLUG	1	1	1	1	
14	5UN-25914-00	.PIN, SLIDE	1	1	1	1	
15	5DH-25914-50	.PIN, SLIDE	1	1	1	1	
16	3JD-25917-00	.BOOT, CALIPER	1	1	1	1	
17	1UY-25937-51	.BOOT 2	1	1	1	1	
18	5DH-25718-01	PROTECTOR, DISK BRAKE	1	1	1	1	
19	95027-06012	BOLT, FLANGE	2	2	2	2	
20	5TA-27491-00	PROTECTOR	1	1	1	1	
21	95027-06016	BOLT, FLANGE	2	2	2	2	

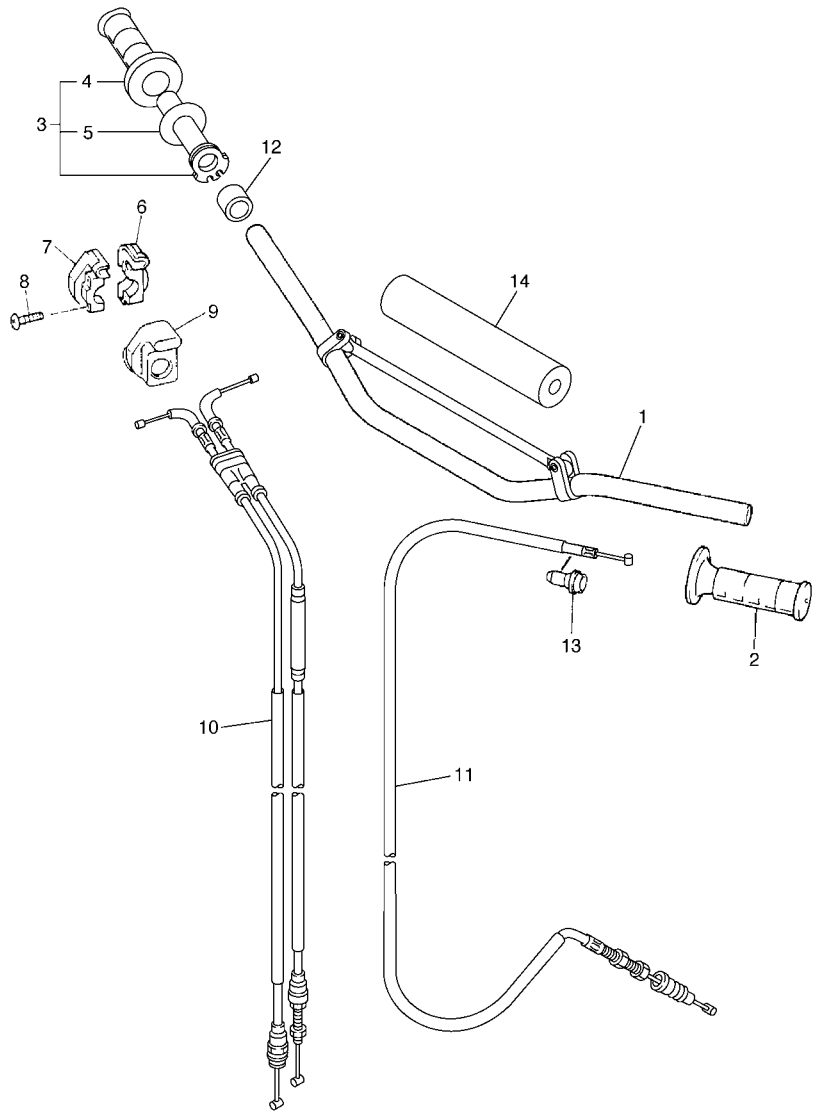

FIG. 32 STEERING HANDLE & CABLE

REF. NO.	PART NO.	DESCRIPTION	5XC5	5XC6	5XC7	5XC8	REMARKS
1	1C3-26111-00	HANDLEBAR	1	1	1	1	
2	4GY-26241-00	GRIP	1	1	1	1	
3	5BE-26240-00	GRIP ASSY	1	1	1	1	
4	4GY-26242-00	.GRIP (RIGHT)	1	1	1	1	
5	3Y1-26249-00	.RING, LEAF	1	1	1	1	
6	5BE-26281-00	CAP, GRIP UPPER	1	1	1	1	
7	5BE-26282-00	CAP, GRIP LOWER	1	1	1	1	
8	98507-05020	SCREW, PAN HEAD	2	2	2	2	
9	5SF-26287-00	COVER, CAP GRIP	1	1	1	1	
10	5XD-26302-00	THROTTLE CABLE ASSY	1	1	1	1	
11	5UL-26335-00	CABLE, CLUTCH	1	1	1	1	
12	90387-225N2	COLLAR	1	1	1	1	
13	5HD-26342-00	BOOT, CABLE	1	1	1	1	
14	1C3-26124-00	PROTECTOR, HANDLEBAR	1	1	1	1	

5XD5100-D320

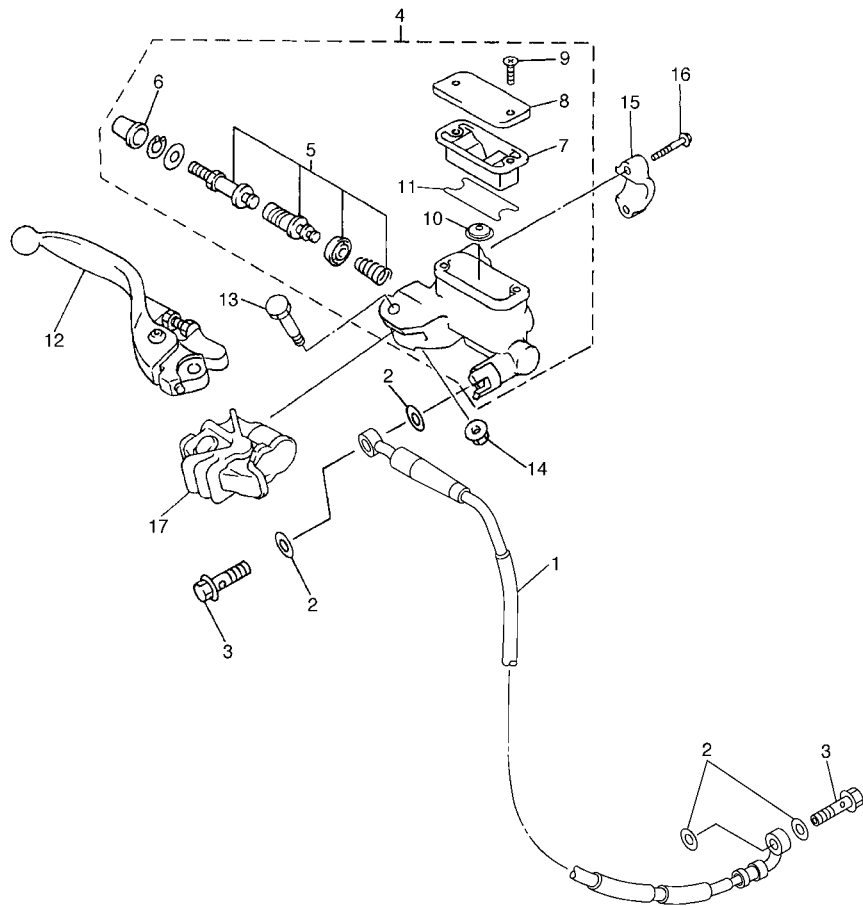

FIG. 33 FRONT MASTER CYLINDER

REF. NO.	PART NO.	DESCRIPTION	5XC5	5XC6	5XC7	5XC8	REMARKS
1	1C3-25872-00	HOSE, BRAKE 1	1	1	1	1	
2	90201-10118	WASHER, PLATE	4	4	4	4	
3	90401-10172	BOLT, UNION	2	2	2	2	
4	5XE-W2587-00	MASTER CYLINDER SUB ASSY	1	1	1	1	
5	5NY-W0041-00	.CYLINDER KIT, MASTER	1	1	1	1	
6	5NY-25868-00	.BOOT, MASTER CYLINDER	1	1	1	1	
7	5XE-25854-00	.DIAPHRAGM, RESERVOIR	1	1	1	1	
8	5MV-25852-01	.CAP, RESERVOIR	1	1	1	1	
9	98706-04012	.SCREW, FLAT HEAD	2	2	2	2	
10	5CG-25715-00	.SEPARATOR ASSY	1	1	1	1	
11	5XE-25853-00	.FLOAT, RESERVOIR	1	1	1	1	
12	5MV-83922-00	LEVER 2	1	1	1	1	
13	5MV-2589F-00	BOLT, LEVER	1	1	1	1	
14	95701-06500	NUT, FLANGE	1	1	1	1	
15	5MV-25867-00	BRACKET, MASTER CYLINDER	1	1	1	1	
16	5MV-25833-00	BOLT, FITTING	2	2	2	2	
17	5NY-26372-00	COVER, HANDLE LEVER 1	1	1	1	1	



5XD5100-D330

FIG. 34 STAND & FOOTREST

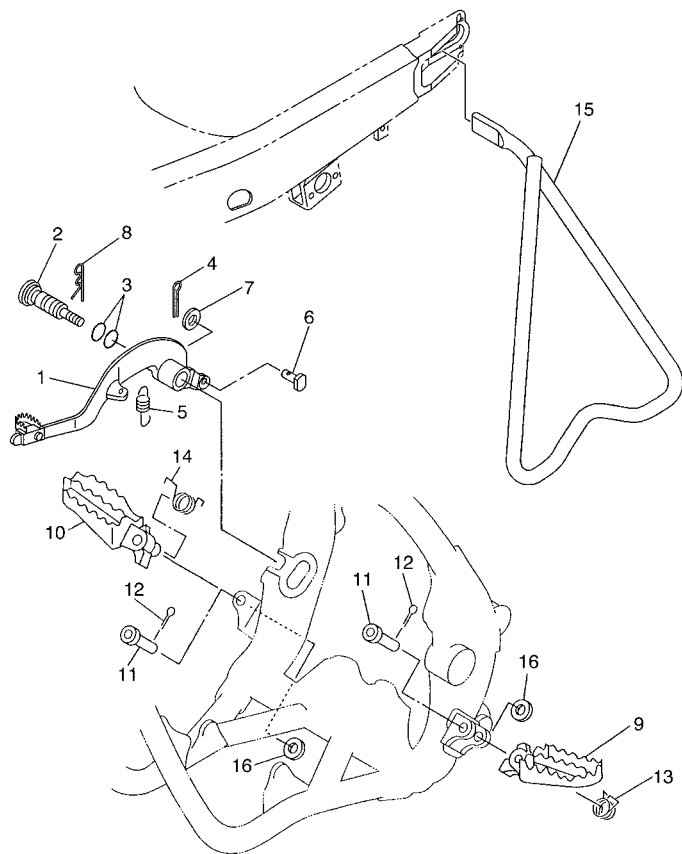

REF. NO.	PART NO.	DESCRIPTION	5XC5	5XC6	5XC7	5XC8	REMARKS
1	1C3-27200-00	PEDAL, BRAKE	1	1	1	1	
2	1C3-27217-00	BOLT	1	1	1	1	
3	93210-11073	O-RING	2	2	2	2	
4	91401-20012	PIN, COTTER	1	1	1	1	
5	90506-16500	SPRING, TENSION	1	1	1	1	
6	90240-08120	PIN, CLEVIS	1	1	1	1	
7	90201-08089	WASHER, PLATE	1	1	1	1	
8	90468-16099	CLIP	1	1	1	1	
9	5XE-27411-01	FOOTREST 1	1	1	1	1	
10	5XE-27421-01	FOOTREST 2	1	1	1	1	
11	90240-10142	PIN, CLEVIS	2	2	2	2	
12	91401-25015	PIN, COTTER	2	2	2	2	
13	90508-282B8	SPRING, TORSION	1	1	1	1	
14	90508-282B9	SPRING, TORSION	1	1	1	1	
15	1C3-27311-00	STAND, SIDE	1	1	1	1	
16	90201-10119	WASHER, PLATE	2	2	2	2	

5XD5100-D340

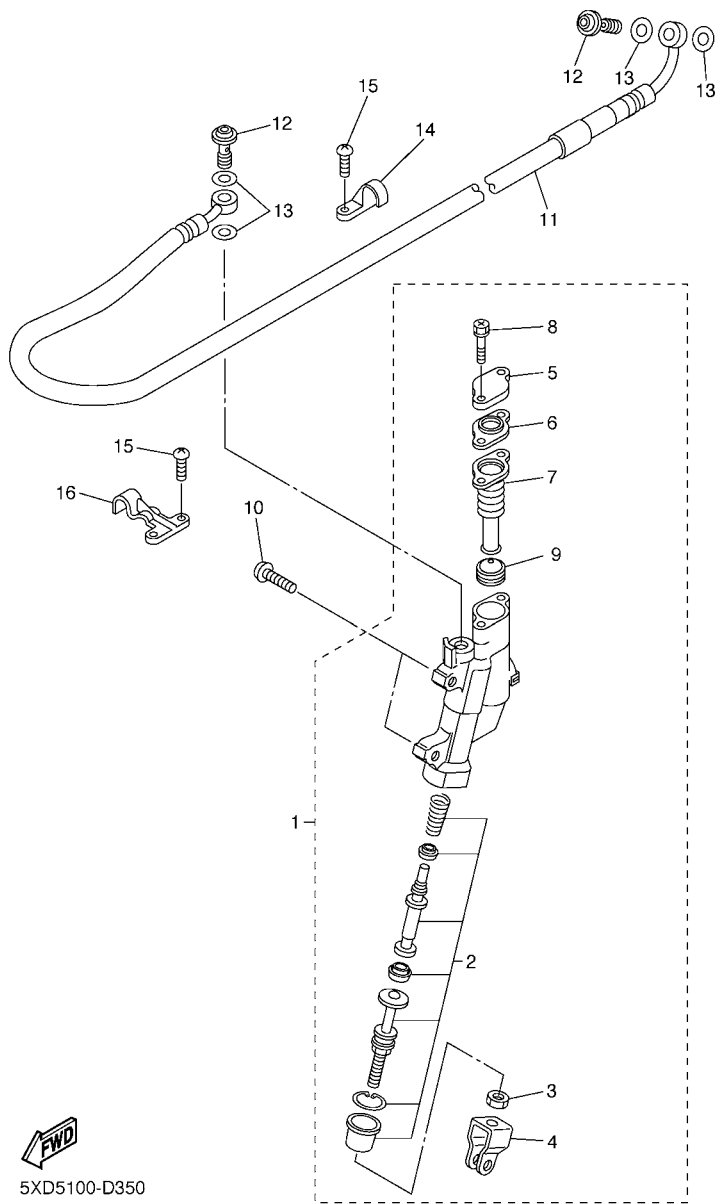

5XD5100-D350

FIG. 35 REAR MASTER CYLINDER

REF. NO.	PART NO.	DESCRIPTION	5XC5	5XC6	5XC7	5XC8	REMARKS
1	5UN-2583V-00	RR. MASTER CYLINDER ASSY.	1	1	1	1	
2	5UN-W0042-50	.CYLINDER KIT, MASTER	1	1	1	1	
3	5UN-27218-00	.NUT	1	1	1	1	
4	5UN-27222-00	.JOINT	1	1	1	1	
5	5UN-25852-50	.CAP, RESERVOIR	1	1	1	1	
6	5UN-2585B-00	.PLATE, DIAPHRAGM	1	1	1	1	
7	5UN-25854-00	.DIAPHRAGM, RESERVOIR	1	1	1	1	
8	5UN-27217-00	.BOLT	2	2	2	2	
9	5CG-25715-00	.SEPARATOR ASSY	1	1	1	1	
10	90111-06029	BOLT	2	2	2	2	
11	5UN-25873-00	HOSE, BRAKE 2	1	1	1	1	
12	90401-10172	BOLT, UNION	2	2	2	2	
13	90201-10118	WASHER, PLATE	4	4	4	4	
14	2VM-25876-00	HOLDER, BRAKE HOSE 2	1	1	1	1	
15	98507-05010	SCREW, PAN HEAD	4	4	4	4	
16	1C3-25876-00	HOLDER, BRAKE HOSE 2	1	1	1	1	

FIG. 36 GENERATOR

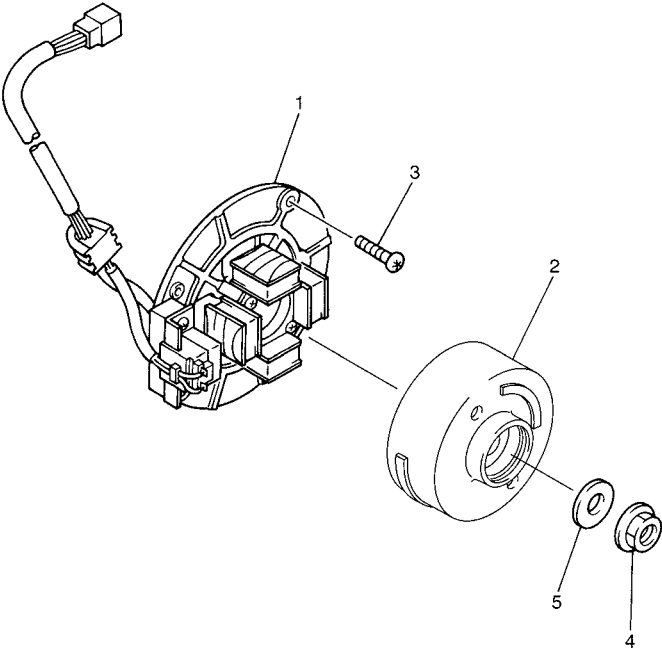

REF. NO.	PART NO.	DESCRIPTION	5XC5	5XC6	5XC7	5XC8	REMARKS
1	5XD-85560-00	BASE ASSY	1	1	1	1	
2	5TA-85550-00	ROTOR ASSY	1	1	1	1	
3	90149-06324	SCREW	3	3	3	3	
4	90179-12248	NUT	1	1	1	1	
5	90201-127E1	WASHER, PLATE	1	1	1	1	

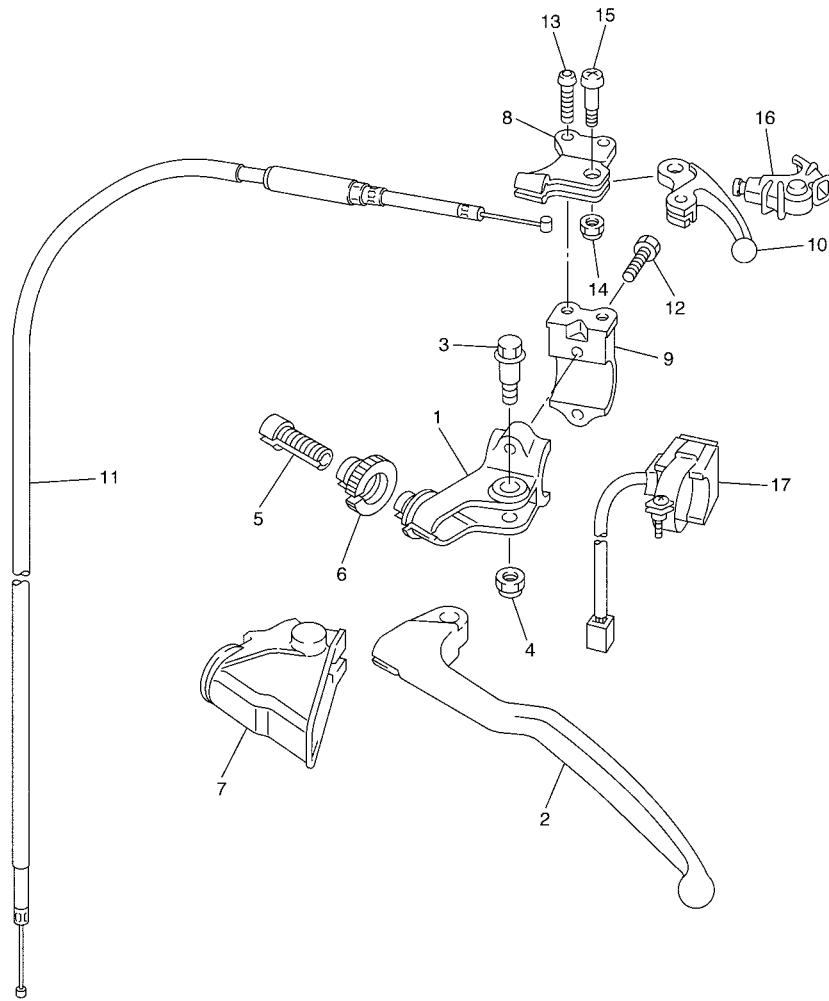

5TA1100-B370

FIG. 37 HANDLE SWITCH & LEVER

REF. NO.	PART NO.	DESCRIPTION	5XC5	5XC6	5XC7	5XC8	REMARKS
1	5XE-82911-00	HOLDER, LEVER 1	1	1	1	1	
2	5MV-83912-00	LEVER 1	1	1	1	1	
3	90109-06034	BOLT	1	1	1	1	
4	5LP-84126-10	NUT, LENS FITTING	1	1	1	1	
5	5TA-26337-00	BOLT, ADJUSTING	1	1	1	1	
6	5HD-83951-00	BOLT, CABLE ADJUSTING	1	1	1	1	
7	5HD-26372-00	COVER, HANDLE LEVER 1	1	1	1	1	
8	5XD-82946-00	HOLDER, STARTER LEVER	1	1	1	1	
9	5XD-82913-00	HOLDER, LEVER LOWER 1	1	1	1	1	
10	5TA-83941-00	LEVER, STARTER	1	1	1	1	
11	5TA-26334-00	CABLE, STARTER 2	1	1	1	1	
12	90101-05033	BOLT	2	2	2	2	
13	92014-05012	BOLT, BUTTON HEAD	2	2	2	2	
14	95607-05100	NUT, U	1	1	1	1	
15	90149-05162	SCREW	1	1	1	1	
16	5TA-26339-00	BOOT	1	1	1	1	
17	1C3-83976-00	SWITCH, HANDLE 1	1	1	1	1	

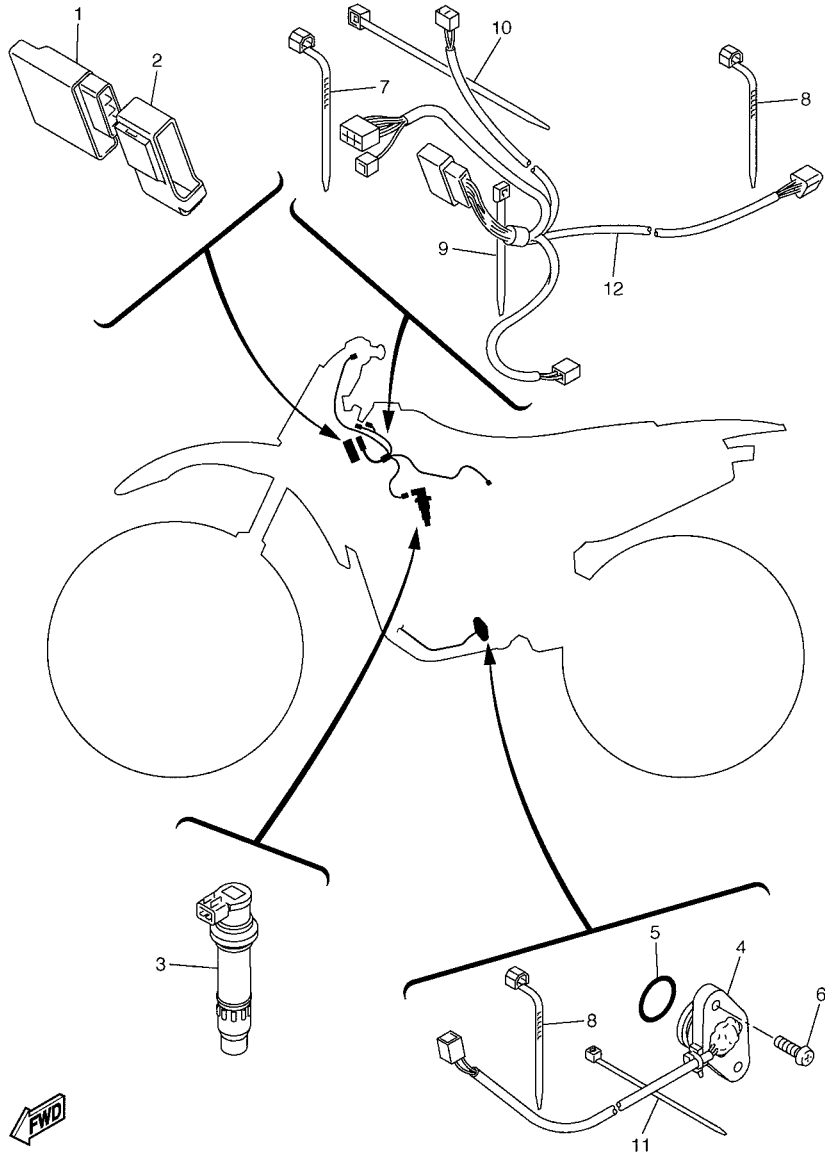

FWD
5XC1100-C380

FIG. 38 ELECTRICAL 1

REF. NO.	PART NO.	DESCRIPTION	5XC5	5XC6	5XC7	5XC8	REMARKS
1	5XC-85540-50	C.D.I. UNIT ASSY	1	1	1	1	
2	5TA-85546-00	BAND	1	1	1	1	
3	5UL-82310-10	IGNITION COIL ASSY	1	1	1	1	
4	5TA-82540-00	NEUTRAL SWITCH ASSY	1	1	1	1	
5	93210-21276	O-RING	1	1	1	1	
6	90154-05026	SCREW, BINDING	2	2	2	2	
7	90464-13077	CLAMP	2	2	2	2	
8	90464-13073	CLAMP	3	3	3	3	
9	90465-13152	CLAMP	1	1	1	1	
10	90465-13275	CLAMP	4	4	4	4	
11	5Y9-12491-00	CLAMP 1	3	3	3	3	
12	5TA-82509-02	WIRE, SUB LEAD	1	1	1	1	

FIG. 39 ALTERNATE FOR CHASSIS

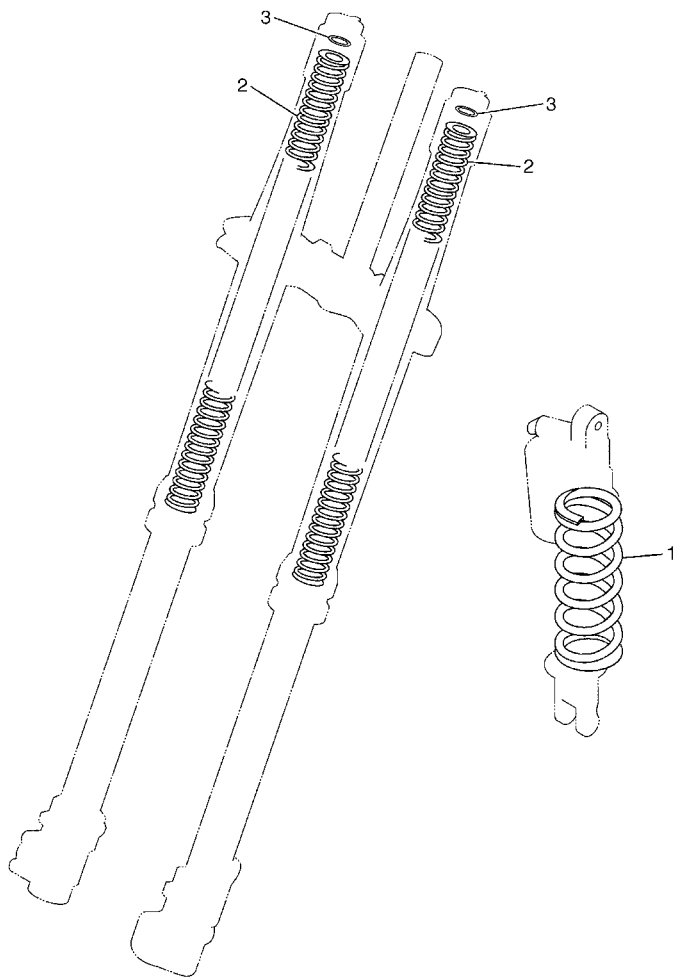

REF. NO.	PART NO.	DESCRIPTION	5XC5	5XC6	5XC7	5XC8	REMARKS
1	5UN-22212-00	SPRING (K=42N/MM)	1	1	1	1	AP
	5UN-22212-10	SPRING (K=44N/MM)	1	1	1	1	AP
	5UN-22212-20	SPRING (K=46N/MM)	1	1	1	1	AP
	5UN-22212-30	SPRING (K=48N/MM)	1	1	1	1	AP
	5UN-22212-40	SPRING (K=50N/MM)	1	1	1	1	AP
	5UN-22212-50	SPRING (K=52N/MM)	1	1	1	1	AP
	5UN-22212-60	SPRING (K=54N/MM)	1	1	1	1	AP
	5UN-22212-70	SPRING (K=56N/MM)	1	1	1	1	AP
	5UN-22212-A0	SPRING (K=APPROX.44N/MM)	1	1	1	1	AP
	5UN-22212-B0	SPRING (K=APPROX.46N/MM)	1	1	1	1	AP
	5UN-22212-C0	SPRING (K=APPROX.48N/MM)	1	1	1	1	AP
	5UN-22212-D0	SPRING (K=APPROX.50N/MM)	1	1	1	1	AP
	5UN-22212-E0	SPRING (K=APPROX.52N/MM)	1	1	1	1	AP
	5UN-22212-F0	SPRING (K=APPROX.54N/MM)	1	1	1	1	AP
5UN-22212-G0	SPRING (K=APPROX.56N/MM)	1	1	1	1	AP	
2	1C3-23141-00	SPRING (K=3.9N/MM)	2	2	2	2	AP
	1C3-23141-10	SPRING (K=4.0N/MM)	2	2	2	2	AP
	1C3-23141-20	SPRING (K=4.1N/MM)	2	2	2	2	AP
	1C3-23141-30	SPRING (K=4.2N/MM)	2	2	2	2	AP
	1C3-23141-40	SPRING (K=4.3N/MM)	2	2	2	2	AP
	1C3-23141-50	SPRING (K=4.4N/MM)	2	2	2	2	AP
	1C3-23141-60	SPRING (K=4.5N/MM)	2	2	2	2	AP
	1C3-23141-70	SPRING (K=4.6N/MM)	2	2	2	2	AP
1C3-23141-80	SPRING (K=4.7N/MM)	2	2	2	2	AP	
3	1C3-23364-00	COLLAR 2	2	2	2	2	UN AP



5XC1100-C390

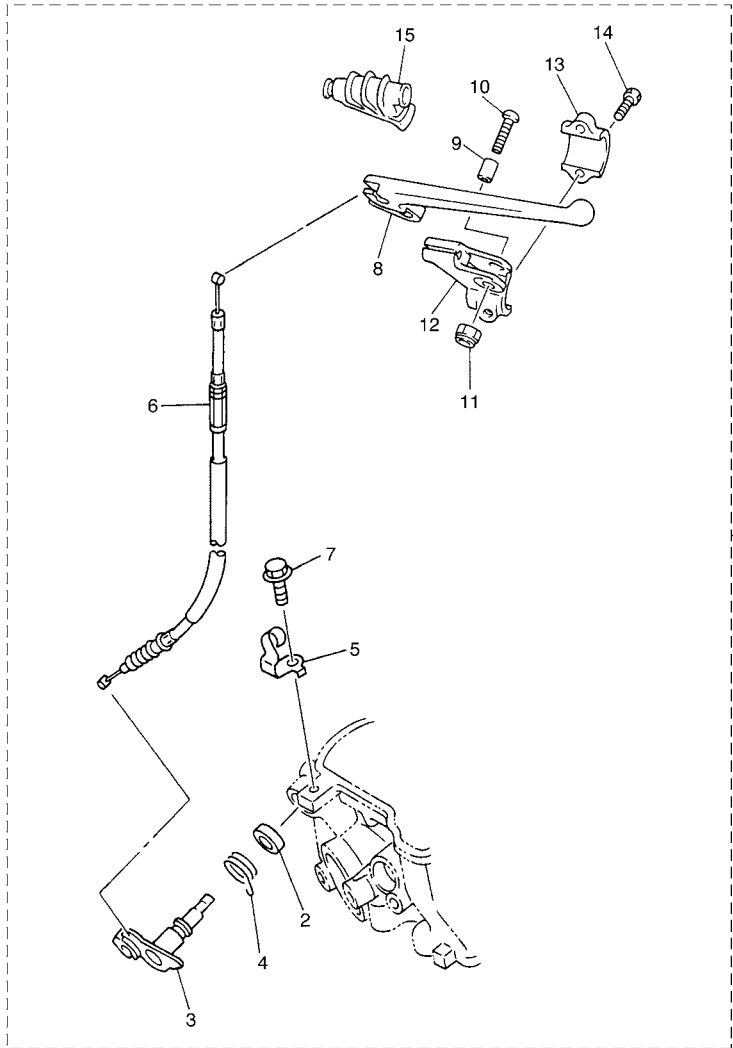

5TA1100-B400

FIG. 40 ALTERNATE DECOMPRESSION KIT

REF. NO.	PART NO.	DESCRIPTION	5XC5	5XC6	5XC7	5XC8	REMARKS
1	5TA-W1228-00	DECOMPRESSION KIT	1	1	1	1	AP
2	93102-12224	.OIL SEAL	1	1	1	1	
3	5BE-12280-10	.DECOMPRESSION ASSY	1	1	1	1	
4	90508-162B2	.SPRING, TORSION	1	1	1	1	
5	5NL-12283-00	.BRACKET, DECOMPRESSION	1	1	1	1	
6	5BE-12292-10	.CABLE, DECOMPRESSION	1	1	1	1	
7	95827-06014	.BOLT, FLANGE	1	1	1	1	
8	583-83981-00	.LEVER, DECOMPRESSION	1	1	1	1	
9	5BE-83913-00	.COLLAR, LEVER 1	1	1	1	1	
10	98507-05020	.SCREW, PAN HEAD	1	1	1	1	
11	95607-05100	.NUT, U	1	1	1	1	
12	5BE-82912-00	.HOLDER, LEVER UPPER 1	1	1	1	1	
13	38V-82913-00	.HOLDER, LEVER LOWER 1	1	1	1	1	
14	97007-05016	.BOLT	2	2	2	2	
15	583-26352-00	.COVER, DECOMPRESSION CABLE	1	1	1	1	

NUMERICAL INDEX

PART NO.	GRID NO.	PART NO.	GRID NO.	PART NO.	GRID NO.	PART NO.	GRID NO.	PART NO.	GRID NO.	PART NO.	GRID NO.
5XC-11102-00	B - 2	1HX-12168-K1	B - 5	5NL-13411-00	B - 10	5JG-14521-00	B - 14	4MX-14943-93	B - 14	5NL-15415-00	C - 6
4KG-1111G-00	B - 3	1HX-12168-M1	B - 5	5NL-13412-00	B - 10	5JG-14522-00	B - 13	4MX-14943-94	B - 14	5BE-15421-01	C - 5
5NL-11133-10	B - 2	1HX-12168-R1	B - 5	5TA-13440-00	B - 11	5JG-14531-00	C - 3	4MX-14943-95	B - 14	5NL-15431-10	C - 6
5NL-11134-10	B - 2	1HX-12168-U1	B - 5	5BE-13447-10	B - 11	3TJ-14536-40	C - 2	4MX-14943-96	B - 14	5NL-15441-01	C - 5
5TA-11166-00	B - 2	1HX-12168-W1	B - 5	5XC-13464-00	B - 10	5JG-14546-01	B - 13	5JG-14947-00	B - 14	5NL-15451-00	C - 6
5BE-11167-00	B - 2	1HX-12168-Y1	B - 5	5XC-13465-00	B - 10	676-14548-00	B - 15	4MX-14948-02	B - 14	5NL-15453-00	C - 6
371-11167-01	B - 2	1HX-12169-11	B - 6	5XC-13597-00	B - 12	4MX-14561-00	C - 2	4MX-14948-03	B - 14	5NL-15462-00	C - 6
5NL-11181-00	B - 2	1HX-12169-31	B - 6	5XC-14101-50	B - 13	6H4-14561-00	C - 2	4MX-14948-04	B - 14	5NL-15601-00	C - 8
5NL-11191-10	B - 2	1HX-12169-50	B - 6	5XC-14101-60	B - 13	5NX-14562-00	C - 2	4MX-14948-05	B - 14	5NL-15620-10	C - 8
5NL-11193-00	B - 3	1HX-12169-70	B - 6	5NL-14105-00	B - 15	5JG-14565-00	C - 2	4MX-14948-06	B - 14	5NX-15621-10	C - 8
5XC-11311-00	B - 3	1HX-12169-90	B - 6	3TJ-14105-40	B - 15	5NL-14591-00	C - 3	4TJ-1494F-11	B - 15	5NL-15641-00	C - 8
5NL-11351-00	B - 3	1HX-12169-E0	B - 6	4MX-14115-00	C - 2	688-14592-00	B - 13	3TJ-1494F-13	B - 14	5NL-15651-00	C - 8
5UM-11387-00	B - 3	1HX-12169-G0	B - 6	3TJ-14137-40	B - 12	5XC-14611-00	C - 4	4TJ-1494F-13	B - 15	5NL-15664-00	C - 8
5XC-11400-00	B - 4	1HX-12169-J0	B - 6			5NL-14613-00	C - 4	3TJ-1494F-14	B - 14	5SG-15668-00	C - 8
5UL-11412-10	B - 4	1HX-12169-L0	B - 6	5BE-14146-00	C - 2	5XC-14628-00	C - 4	3TJ-1494F-15	B - 14	4GY-15671-00	C - 8
5UL-11422-00	B - 4	1HX-12169-N0	B - 6	5PA-14146-00	C - 3	5NL-1469A-00	C - 4	4TJ-1494F-15	B - 15	214-15686-00	C - 8
5NL-11454-00	B - 4	1HX-12169-T0	B - 6	5TA-14155-00	C - 2	5BE-1469E-00	C - 4	3TJ-1494F-16	B - 14	5NL-16111-00	C - 9
5NL-11455-00	B - 4	5UL-12170-10	B - 7	633-14159-00	B - 15	5BE-14747-00	C - 4	3TJ-1494F-17	B - 14	5NL-16150-10	C - 9
5NL-11531-00	B - 4	5UL-12180-10	B - 7	3TJ-14159-40	B - 14	3VD-14755-00	C - 4	4TJ-1494F-17	B - 15	5NL-16154-00	C - 9
5NL-11536-00	B - 4	5TA-12210-00	B - 7	5TA-14171-00	C - 2	4BD-14766-00	C - 4	3TJ-1494F-18	B - 14	3XJ-16321-00	C - 9
5NL-11603-00	B - 4	4FM-12213-00	B - 7	3TJ-14191-40	B - 15	5UL-14788-00	C - 4	3TJ-1494F-19	B - 14	5DH-16321-00	C - 9
5NL-11631-20	B - 4	5BE-12241-00	B - 7	5UL-14196-00	C - 2	5JG-14916-E1	B - 13	4TJ-1494F-19	B - 15	5NL-16325-00	C - 9
5NL-11633-00	B - 4	5NL-12251-10	B - 7	5TA-14197-00	C - 2	5NL-14916-E1	B - 13	4TJ-1494F-21	B - 15	5NL-16325-10	C - 9
5UL-11651-00	B - 4	5NL-12252-00	B - 7	5NX-14216-00	C - 2	5NL-14916-EN	B - 13	4TJ-1494F-23	B - 15	5HD-16351-00	C - 9
5XC-11681-00	B - 4	5BE-12280-10	E - 14	5TA-14227-00	B - 12	5JG-14916-EP	B - 13	4TJ-1494F-25	B - 15	5NL-16356-00	C - 9
5NL-12111-10	B - 5	5NL-12283-00	E - 14	5TA-14239-00	B - 12	5NL-14916-EP	B - 13	4TJ-1494F-27	B - 15	5NL-16357-10	C - 9
5NL-12112-10	B - 5	5BE-12292-10	E - 14	5TA-14261-00	C - 2	5JG-14916-ER	B - 13	4TJ-1494F-28	B - 15	5NL-16371-00	C - 9
5NL-12113-00	B - 5	5NL-1240A-10	B - 9	5JG-14264-00	B - 14	5NL-14916-ER	B - 13	4TJ-1494F-29	B - 15	5JG-16381-00	C - 9
5NL-12114-00	B - 5	5NL-12422-10	B - 8	3TJ-14267-40	B - 13	5JG-14916-ES	B - 13	4TJ-1494F-30	B - 15	5NL-16383-10	C - 9
5NL-12116-00	B - 5	5NL-12439-00	B - 8	5JG-14275-00	B - 14	5NL-14916-ES	B - 13	4TJ-1494F-31	B - 15	4JT-16384-00	C - 9
1HX-12117-00	B - 5	5DH-12451-00	B - 8	5TA-14293-00	B - 12	5JG-14916-ET	B - 13	4TJ-1494F-32	B - 15	5NL-16384-00	C - 9
1WG-12117-00	B - 5	5XC-12459-00	B - 8	3TJ-14293-40	B - 15	5NL-14916-ET	B - 13	5JG-14951-00	B - 13	5NL-17121-00	C - 11
1HX-12118-00	B - 5	5NL-12461-10	B - 9	5TA-14335-00	C - 2	5JG-14916-EU	B - 13	5JG-14959-00	B - 13	5NL-17131-10	C - 11
1WG-12118-00	B - 5	5HD-12462-00	B - 9	5JG-14346-00	C - 2	5NL-14916-EU	B - 13	5JG-14984-00	B - 15	5NL-17141-10	C - 11
4SV-12119-00	B - 5	5NL-12481-00	B - 9	5TA-14371-00	C - 2	5JG-14916-EV	B - 13	4SR-14985-00	B - 15	5NL-17151-00	C - 11
4TV-12119-00	B - 5	5Y9-12491-00	E - 12	5TA-14374-00	C - 2	5JG-14922-00	C - 2	5TA-14987-00	B - 12	5NL-17211-10	C - 11
5NL-12121-10	B - 5	5NL-12564-00	C - 6	5JG-14379-00	C - 2	3TJ-14933-40	C - 2	5TJ-14987-00	C - 2	5NL-17221-00	C - 11
3GM-12126-00	B - 5	5SG-12576-00	B - 9	5JG-14388-00	B - 13	5TA-14934-00	C - 2	5TA-14991-00	C - 2	5NL-17231-10	C - 11
3FV-12153-10	B - 6	5SG-12577-00	B - 9	4MX-14392-00	B - 15	5JG-14940-16	B - 15	4FN-14997-00	B - 13	5NL-17241-10	C - 11
3LN-12153-10	B - 6	5SG-12578-00	B - 9	5TA-14401-01	B - 12	5JG-14940-17	B - 15	5TA-14997-00	C - 2	5NL-17251-10	C - 11
1HX-12168-00	B - 5	5SG-12579-00	B - 9	5XD-14417-00	B - 12	5JG-14940-18	B - 15	5XC-15150-00	C - 5	5NL-17402-00	C - 11
1HX-12168-20	B - 5	583-13113-00	B - 11	5TA-14428-00	B - 12	5JG-14940-76	B - 15	5UL-15362-01	D - 2	5NL-17411-10	C - 11
1HX-12168-40	B - 5	5NL-131161-00	B - 11	5NY-14442-00	B - 12	5TA-14943-27	B - 14	3Y1-15363-00	C - 6	5NL-17466-00	C - 5
1HX-12168-60	B - 5	5NL-13171-00	B - 11	4XM-14451-00	B - 12	4MX-14943-42	B - 14	5XD-15378-00	C - 7	5NL-17471-00	C - 12
1HX-12168-80	B - 5	5SG-13300-00	B - 10	5XD-14453-00	B - 12	4MX-14943-43	B - 14	4JT-15381-01	C - 5	5UL-18101-00	C - 14
1HX-12168-A0	B - 5	5NL-13320-00	B - 10	5NY-14455-10	B - 12	4MX-14943-44	B - 14	5BE-15383-01	C - 5	5UL-18110-00	C - 14
1HX-12168-F0	B - 5	5NL-13341-00	B - 10	5BE-14458-00	B - 12	4MX-14943-45	B - 14	5NL-15388-00	C - 5	5LP-18122-01	C - 14
1HX-12168-H1	B - 5	5BE-13342-00	B - 10	5NY-14459-00	B - 12	4MX-14943-92	B - 14	5NL-15411-10	C - 6	3XK-18140-00	C - 13

NUMERICAL INDEX

PART NO.	GRID NO.	PART NO.	GRID NO.	PART NO.	GRID NO.	PART NO.	GRID NO.	PART NO.	GRID NO.	PART NO.	GRID NO.
5BE-18172-00	C - 14	1C3-22151-00	D - 5	4EW-22474-00	D - 7	5XE-23389-00	D - 9	1C3-25452-00	E - 4	5BE-26282-00	E - 6
3XJ-18173-10	C - 14	5UN-22176-00	D - 7	3JE-22475-00	D - 7	4EW-23416-00	D - 9	5CG-25715-00	E - 7	5SF-26287-00	E - 6
3XJ-18178-00	C - 14	4EW-22178-01	C - 15	5NY-22475-00	D - 7	5XE-23435-20	D - 9		E - 9	5XD-26302-00	E - 6
3XJ-18182-00	C - 14	3JD-22178-20	C - 15	5UN-22898-60	E - 5	5XE-23441-00	D - 9	5DH-25718-01	E - 5	5TA-26334-00	E - 11
3XJ-18184-00	C - 14	1C3-2217A-00	D - 5	1C3-22969-00	D - 5	1C3-23466-00	D - 11	1C3-2580T-00	E - 2	5UL-26335-00	E - 6
4EW-18185-00	C - 14	1C3-2217F-00	D - 5	5XC-23102-50	D - 10	1C3-23467-00	D - 11	1C3-2580W-10	E - 5	5TA-26337-00	E - 11
5NL-18501-00	C - 13	5MV-22184-00	D - 7	5XC-23102-60	D - 10	1C3-23485-10	D - 9	5MV-2581T-00	E - 2	5TA-26339-00	E - 11
5NL-18502-00	C - 13	1C3-22199-00	D - 5	5XC-23103-50	D - 10	5XD-24110-01	D - 12	5UN-25827-60	E - 5	5HD-26342-00	E - 6
5NL-18503-00	C - 13	5XC-22201-50	D - 7	5XC-23103-60	D - 10	4EW-2412F-00	D - 12	5UN-25828-60	E - 5	583-26352-00	E - 14
5NL-18541-00	C - 13	5XC-22201-60	D - 7	1P8-23110-L0	D - 10	5XE-24144-00	D - 12	5NY-2582W-00	E - 5	5HD-26372-00	E - 11
4BA-18542-00	C - 13	5XC-22201-70	D - 7	1C3-23111-L0	D - 10	5SF-24173-00	D - 12	5MV-25833-00	E - 7	5NY-26372-00	E - 7
5DH-18562-00	C - 5	5XC-22201-80	D - 7	5XE-23113-00	D - 9	5XE-24176-00	D - 12	5UN-2583V-00	E - 9	1C3-27200-00	E - 8
5XC-21101-50	C - 15	5XC-22201-90	D - 7	1C3-23118-L0	D - 10	22W-24181-00	C - 4	5DH-25849-00	E - 2	1C3-27217-00	E - 8
5XD-21190-50	C - 15	5XC-22210-50	D - 7	1P8-23120-L0	D - 10	4SS-24181-00	D - 12	5MV-25852-01	E - 7	5UN-27217-00	E - 9
5TA-21274-01	D - 2	5XC-22210-60	D - 7	5XE-23125-L0	D - 10	5BE-24182-00	D - 12	5UN-25852-50	E - 9	5UN-27218-00	E - 9
1C3-2135F-00	D - 6	5XC-22210-70	D - 7	1C3-23136-L0	D - 10	5NY-24183-00	D - 12	5XE-25853-00	E - 7	5UN-27222-00	E - 9
1C3-2139F-00	D - 6	5XC-22210-80	D - 7	1C3-23141-00	E - 13	5NY-24186-00	D - 12	5UN-25854-00	E - 9	1C3-27311-00	E - 8
5XC-21417-50	D - 2	5XC-22210-90	D - 7	1C3-23141-10	E - 13	5XD-24240-10	D - 13	5XE-25854-00	E - 7	5XE-27411-01	E - 8
5XC-21417-60	D - 2	5UN-22212-00	E - 13	1C3-23141-20	E - 13	3XJ-24380-00	D - 12	5UN-2585B-00	E - 9	5XE-27421-01	E - 8
5NL-21425-00	C - 15	5UN-22212-10	E - 13	1C3-23141-30	E - 13	4DP-24500-01	D - 12	5MV-25867-00	E - 7	5TA-27491-00	E - 5
5NL-21425-10	C - 15	5UN-22212-20	E - 13	1C3-23141-40	E - 13	4X8-24512-00	D - 12	5N9-25868-00	E - 7	5TA-2814F-00	D - 2
5XD-21455-60	C - 15	5UN-22212-30	D - 8	1C3-23141-50	E - 13	3AC-24523-00	D - 12	1C3-25872-00	E - 7	5ET-28166-00	D - 2
5NL-21471-01	D - 2		E - 13	1C3-23141-60	E - 13	3AJ-24534-01	D - 12	5UN-25873-00	E - 9	5UL-82310-10	E - 12
5NL-2147A-00	D - 2	5UN-22212-40	E - 13	1C3-23141-70	E - 13	5NY-24610-00	D - 12	1C3-25875-00	E - 2	5TA-82509-02	E - 12
5HD-21511-00	D - 3	5UN-22212-50	E - 13	1C3-23141-80	E - 13	5XD-2470F-00	D - 14	1C3-25876-00	E - 9	5TA-82540-00	E - 12
5UN-2153A-00	D - 6	5UN-22212-60	E - 13	1P8-23141-L0	D - 10	5XD-24710-00	D - 14	2VM-25876-00	E - 9	5XE-82911-00	E - 11
4XL-2153A-10	D - 11	5UN-22212-70	E - 13	5XE-23144-L0	D - 10	5NY-25104-00	D - 15	5MV-2589F-00	E - 7	5BE-82912-00	E - 14
4ES-2153E-01	D - 3	5UN-22212-A0	E - 13	1C3-23145-L0	D - 10	5NY-25111-00	D - 15	5UN-25914-00	E - 5	38V-82913-00	E - 14
5XD-21610-00	D - 3	5UN-22212-B0	E - 13	5XE-23146-L0	D - 10	5NY-25117-00	D - 15	5DH-25914-50	E - 5	5XD-82913-00	E - 11
5XD-21635-00	D - 3	5UN-22212-C0	E - 13	1C3-2314F-L0	D - 10	1C3-25181-00	D - 15	3SP-25914-51	E - 2	5XD-82946-00	E - 11
5XC-2163G-00	D - 3	5UN-22212-D0	E - 13	5XE-23153-L0	D - 10	5NY-25183-00	D - 15	5DH-25916-00	E - 2	5MV-83912-00	E - 11
5TA-21642-00	D - 3	5UN-22212-E0	E - 13	2HH-23158-L0	D - 10	5NY-25186-00	D - 15		E - 5	5BE-83913-00	E - 14
5TA-21711-00	D - 4	5UN-22212-F0	E - 13	1C3-2315H-00	D - 11	5HD-25304-00	E - 3	3JD-25917-00	E - 2	5MV-83922-00	E - 7
5TA-21721-00	D - 4	5UN-22212-G0	E - 13	1C3-2315J-00	D - 11	5ET-25311-00	E - 3		E - 5	5TA-83941-00	E - 11
5NL-2172A-11	D - 4	3SP-22213-00	D - 7	5XC-2316A-N0	D - 10	5ET-25317-00	E - 3	5DH-25919-00	E - 2	5HD-83951-00	E - 11
5TA-21730-00	D - 4	5XE-22214-00	D - 8	5XC-2316A-P0	D - 10	4XM-25364-00	E - 3	5DH-25919-50	E - 5	1C3-83976-00	E - 11
5XD-2173E-10	D - 4	5MV-22224-00	D - 7	1C3-2316E-L0	D - 10	5ET-25367-00	E - 4	8CR-25924-00	E - 5	583-83981-00	E - 14
5XD-2173F-10	D - 4	4JX-22226-00	D - 7	1C3-23170-L0	D - 10	1C3-25381-00	E - 4	3SP-25926-51	E - 2	5LP-84126-10	E - 11
5TA-21740-00	D - 4	3SP-22234-00	D - 7	1C3-23170-M0	D - 10	5UN-25383-00	E - 4	5DH-25933-00	E - 2	5XC-85540-50	E - 12
5TA-2174A-00	D - 4	5NY-22241-00	D - 8	5XE-23171-L0	D - 10	1C3-25388-00	E - 4	1UY-25937-51	E - 2	5TA-85546-00	E - 12
5TA-2174T-00	D - 3	5XE-22242-00	D - 8	5DH-23183-00	D - 7	1C3-25389-00	E - 4		E - 5	5TA-85550-00	E - 10
5TA-21756-00	C - 15	1C3-22253-00	D - 7	509-23184-L0	D - 7	4XM-25394-00	E - 3	1C3-26111-00	E - 6	5XD-85560-00	E - 10
5MV-2175C-00	D - 4	5MV-22253-00	D - 7	5TJ-2319U-00	D - 9	5SF-25394-00	D - 15	1C3-26124-00	E - 6	5TA-85885-00	C - 2
1C3-22210-00	D - 5	4AA-22259-40	D - 7	5XC-23340-M0	D - 11	1C3-25447-00	E - 3	5BE-26240-00	E - 6	5NY-W0041-00	E - 7
5XD-22211-50	D - 6	4AA-22259-50	D - 7	5NY-23346-L0	D - 11	1C3-25448-00	E - 3	4GY-26241-00	E - 6	5UN-W0042-50	E - 9
1C3-22212-00	D - 6	4AA-22259-60	D - 7	3SP-23356-L0	D - 11	1C3-25449-00	E - 3	4GY-26242-00	E - 6	5MV-W0045-01	E - 2
1C3-222128-00	D - 5	4AA-22259-80	D - 7	5TA-23357-00	D - 9	1C3-25450-00	E - 3	3Y1-26249-00	E - 6	1C3-W0046-10	E - 5
5XD-22141-50	D - 5	1C3-22355-00	D - 5	1C3-23364-00	E - 13	1C3-25451-00	E - 4	5BE-26281-00	E - 6	3JD-W0047-00	E - 2

NUMERICAL INDEX

PART NO.	GRID NO.	PART NO.	GRID NO.	PART NO.	GRID NO.	PART NO.	GRID NO.	PART NO.	GRID NO.	PART NO.	GRID NO.
5UN-W0047-50	E - 5	90149-06126	C - 5	90201-162H4	C - 8	90430-06014	B - 7	91317-06012	B - 9	93300-60804	C - 15
1UY-W0048-50	E - 2	90149-06250	B - 4	90201-167P7	C - 8		B - 8	91317-06025	B - 11	93306-00105	B - 8
	E - 5	90149-06324	E - 10	90201-177G4	C - 8	90430-08119	B - 11	91317-06045	C - 5	93306-00317	C - 11
5UN-W0057-00	E - 2	90149-06326	C - 5	90201-203U1	E - 4		C - 15	91317-06055	C - 5	93306-00320	C - 11
5UN-W0057-50	E - 5	90149-06327	E - 2	90201-20685	C - 8	90430-10188	B - 11	91317-06065	B - 11	93306-07202	E - 3
5TA-W1228-00	E - 14	90151-04001	D - 5	90201-21013	D - 5		C - 5	91317-06070	C - 5	93306-20335	B - 4
5XE-W2587-00	E - 7	90152-06010	C - 8	90201-247L2	D - 9	90445-09095	D - 12	91317-08020	C - 4	93306-20447	C - 11
5UL-Y1475-01	C - 4	90154-05026	E - 12	90201-286K9	D - 9	90445-09220	D - 12	91401-20012	E - 8	93306-20648	B - 4
5UL-Y1475-30	C - 4	90159-06078	D - 4	90202-05193	D - 12	90445-11185	D - 12	91401-25015	E - 8	93306-27205	E - 3
90101-05033	E - 11	90159-06092	C - 9	90202-08045	B - 13	90445-112K0	B - 2	91808-16023	B - 2	93306-27208	C - 11
90101-06001	C - 8	90170-14171	B - 4	90206-06090	C - 4	90450-22017	B - 9	91812-16001	C - 6	93306-90403	D - 15
90101-06034	C - 14	90170-16326	C - 9	90209-06096	B - 12		B - 10	91A20-05065	B - 9	93306-90501	C - 13
90101-08777	E - 4	90179-06568	D - 5	90209-16008	D - 5	90450-25037	B - 9	92014-05012	E - 11	93310-63238	B - 4
90105-06027	B - 2	90179-08299	E - 4	90209-20008	C - 11	90450-32015	B - 9	92017-08055	C - 15	93311-32261	B - 4
90105-06055	D - 4	90179-08674	C - 15	90209-23012	C - 11	90450-54002	B - 12	92907-06600	B - 7	93315-32165	D - 5
90105-06553	C - 5	90179-10658	C - 15	90215-14204	B - 4	90450-57008	B - 12		D - 2	93315-32166	D - 5
	C - 12	90179-12248	E - 10	90215-16289	C - 9	90450-61001	B - 12	93101-14164	C - 6	93317-11287	C - 9
90105-065A1	C - 6	90179-16002	D - 15	90215-20003	C - 9	90464-13073	E - 12	93102-12106	B - 8	93317-22262	D - 5
90105-08057	C - 4	90179-18001	C - 9		C - 11	90464-13077	E - 12	93102-12224	C - 9	93332-00068	D - 9
	C - 15		C - 12	90240-08120	E - 8	90465-08029	C - 6		C - 14	93332-00081	D - 11
90105-08120	C - 15	90179-28003	D - 9	90240-10142	E - 8	90465-10013	C - 5		E - 14	93340-21008	C - 11
90105-08659	C - 4	90183-06023	B - 12	90267-32070	B - 12	90465-13152	D - 12	93102-18278	C - 8	93342-22217	D - 5
	E - 2	90185-08169	E - 4	90267-48121	C - 4		E - 12	93102-26468	D - 15	93410-20038	C - 8
90105-09002	B - 2	90185-10060	D - 8	90280-03001	B - 4	90465-13275	E - 12	93102-28010	C - 11	93410-22039	C - 11
90105-09004	B - 2	90185-14007	D - 6	90338-18004	B - 7	90467-09006	B - 9	93106-22019	D - 5	93410-26067	C - 11
90105-10072	C - 15	90185-16127	D - 5	90338-18176	D - 2	90467-10008	D - 12	93106-30044	E - 3	93420-16086	B - 4
90105-10733	C - 15	90185-20168	E - 4	90340-12112	B - 2	90467-11106	B - 3	93106-30045	E - 3	93440-07149	B - 2
90109-06034	E - 11	90201-03313	B - 12	90340-14128	C - 6	90467-14015	B - 2	93109-11073	B - 8	93440-07182	B - 8
90109-063F8	C - 13	90201-06557	D - 3	90340-32123	C - 6	90468-16099	E - 8	93109-21001	D - 6		C - 9
90109-06418	B - 7	90201-06571	B - 9	90387-06009	D - 3	90480-08608	E - 4	93109-25001	D - 5	93440-10153	B - 2
90109-065G2	B - 11	90201-08008	C - 4	90387-06065	B - 9	90480-15528	B - 9	93109-28043	D - 5		B - 10
90109-065G4	E - 5	90201-08089	E - 8	90387-06090	D - 3	90480-18549	D - 12	93210-07003	B - 11	93440-41178	B - 7
90109-066F0	B - 3	90201-080H1	C - 9	90387-0814J	C - 4	90501-043E0	B - 11	93210-07135	B - 11	93503-08007	B - 11
90109-067F4	B - 12	90201-08326	C - 8	90387-086N4	C - 15	90501-052G5	C - 14	93210-08001	D - 2	93507-32009	C - 8
90109-081G1	E - 4		E - 4	90387-124F4	C - 14	90501-06022	C - 13	93210-09008	B - 11	93511-32027	C - 9
90109-082G0	C - 8	90201-08410	C - 2	90387-14006	D - 6	90501-147A5	C - 8	93210-10197	B - 10	93603-16219	B - 10
90110-06058	B - 10	90201-08512	B - 8	90387-16010	D - 5	90501-16016	C - 8		C - 5	93604-10011	B - 8
90111-06029	E - 9	90201-086P8	C - 15	90387-18004	D - 5	90501-224J9	C - 9	93210-11073	E - 8	93608-33002	C - 14
90116-06541	B - 2	90201-096J9	B - 2	90387-18007	C - 5	90506-16500	E - 8	93210-12759	B - 11	93612-16254	B - 3
90119-06001	D - 2	90201-10118	E - 7	90387-18009	D - 5	90508-12018	C - 10	93210-14369	C - 6		C - 5
90119-06096	D - 3		E - 9	90387-20006	C - 11	90508-162B2	E - 14	93210-15414	B - 9	9383B-13218	C - 11
90119-06192	D - 3	90201-10119	E - 8	90387-22001	C - 11	90508-26561	C - 13	93210-16716	C - 6	94108-21012	D - 15
90119-06225	D - 3	90201-12166	B - 10	90387-225N2	E - 6	90508-282B8	E - 8	93210-17570	C - 8	94108-21015	D - 15
	D - 9	90201-127E1	E - 10	90401-08038	B - 11	90508-282B9	E - 8	93210-19123	C - 6	94108-2112Y	D - 15
90119-08238	D - 4	90201-145M4	C - 15	90401-10159	B - 11	90508-291A8	C - 14	93210-196A4	C - 11	94110-19009	E - 3
90122-06035	B - 12	90201-14740	D - 6	90401-10172	E - 7	90508-30743	C - 8	93210-21276	E - 12	94110-19011	E - 3
90149-05162	E - 11	90201-15701	C - 6		E - 9	91314-06030	B - 10	93210-32172	C - 6	94110-1913B	E - 3
90149-06011	D - 12	90201-160F6	D - 5	90430-06014	B - 2	91316-04012	B - 13	93210-47675	B - 11	94209-21229	D - 15

NUMERICAL INDEX

PART NO.	GRID NO.	PART NO.	GRID NO.	PART NO.	GRID NO.	PART NO.	GRID NO.	PART NO.	GRID NO.	PART NO.	GRID NO.
94210-19222	E - 3	95707-06500	D - 11								
94210-19224	E - 3	95707-08500	B - 2								
94227-21101	D - 15		C - 15								
94309-21161	D - 15	95817-08016	D - 2								
94316-19156	E - 3	95817-10050	C - 15								
94321-19135	E - 3	95827-06010	B - 9								
94330-21084	D - 15	95827-06014	E - 14								
94416-21005	D - 15	95827-06016	D - 4								
94418-19003	E - 3	95827-08012	C - 15								
94591-53114	B - 7	97007-05016	E - 14								
94681-68001	E - 4	97027-06012	D - 2								
94701-00410	B - 2	97027-06016	B - 7								
94701-00411	B - 2	97707-60016	D - 3								
94703-00410	B - 2	98502-04012	B - 13								
94703-00411	B - 2	98507-03008	D - 12								
95027-06010	B - 2	98507-05010	E - 9								
	C - 10	98507-05020	E - 6								
	D - 5		E - 14								
	E - 2	98507-06025	C - 5								
95027-06012	B - 8	98706-04012	E - 7								
	B - 11	98707-06025	D - 12								
	D - 2	98907-06025	D - 12								
	E - 5	98980-06008	C - 4								
95027-06016	D - 12	99001-08600	B - 10								
	E - 5	99009-12400	B - 10								
95027-06020	C - 14	99009-16400	C - 8								
	D - 9	99009-17400	C - 8								
95027-06025	B - 7	99009-22500	C - 6								
	B - 8	99009-45500	E - 3								
	B - 9	99530-08012	B - 10								
	B - 10	99530-08016	C - 6								
	C - 6	99530-10114	B - 10								
95027-06035	B - 3		C - 5								
	C - 6	99530-10116	C - 5								
95027-06050	D - 5	9Y581-92111	E - 4								
95027-06065	B - 8										
95027-08012	D - 2										
95027-08035	D - 9										
95027-08040	C - 15										
	D - 9										
95027-08065	C - 15										
95027-10016	C - 5										
95607-05100	E - 11										
	E - 14										
95607-10200	D - 8										
95617-08620	B - 2										
95701-06500	E - 7										
95704-06500	B - 3										