



PARTS CATALOGUE

YZ250FV (5XC9,5XCD) U.S.A.,CANADA

YZ250F (5XCA) EUROPE

YZ250F (5XCB,5XCE) JAPAN

YZ250F (5XCC,5XCF) OCEANIA,SOUTH AFRICA

YZ250FV/YZ250F
PARTS CATALOGUE
©2005 by Yamaha Motor Co., Ltd.
1st edition, September 2005
All rights reserved.
Any reprinting or unauthorized use
without the written permission of
Yamaha Motor Co., Ltd.
is expressly prohibited.
Printed in Japan.

A3

YZ250FV/YZ250F



YZ250FV/YZ250F



FOREWORD

This Parts Catalogue is related to the parts for the model(s) on the cover page. When you are ordering replacement parts, please refer to this Parts Catalogue and quote both part numbers and part names correctly.

1. Modifications or additions which have been made after the issue of the Parts Catalogue will be announced in the Parts News.

It is advisable that you make the necessary corrections to the Parts Catalogue according to the Parts News.

2. Abbreviations

The following abbreviations are used in this Parts Catalogue.

“UR” Use specified parts number.

“UN” Use as many as needed.

“AP” Alternate Parts

“LM” Locally Made (Parts need to be ordered locally)

“F#” Frame No. (Applicable machine No.)

“O/S” Over Size

3. The number of components for assembly

- Parts, which are to be supplied in an assembly, are listed with a dot (.) in front of the part name as shown below.
- The numeral appearing to the right of each component part indicates the quantity of parts for each assembly unit.

PART NO.	DESCRIPTION	Q'TY	REMARKS
2F5-83310-60	FRONT FLASHER LIGHT ASSY	2	
115-83311-60	.BULB (6V-18W)	1	

4. Applicable colours of graphics are represented in the “REMARKS” as shown below.

PART NO.	DESCRIPTION	Q'TY	REMARKS
2N4-24110-00-X5	FUEL TANK COMP.	2	MXR
3J1-24240-10	.GRAPHIC, FUEL TANK	1	FOR MXR

5. Note that the illustrations for reference in finding parts numbers are not to be used for assembling. When assembling, please use the applicable service manual.

6. The asterisk (*) before a reference number indicates modified items after the first edition.

FOREWORD

7. Applicable Serial No.

Engine Serial No.

Frame Serial No.

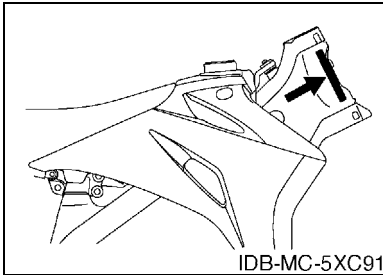
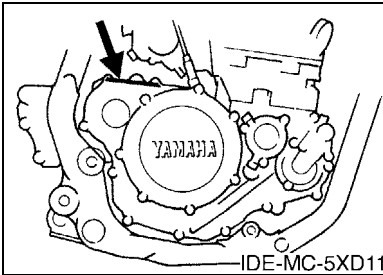

8. Applicable Colour Code (The (*) mark shows Model colour.)

Abbreviation	Colour Name	Colour Code
DPBSE(*)	DEEP PURPLISH BLUE SOLID E	0583
LRY51(*)	LIGHT REDDISH YELLOW SOLID 1	0386

MODEL LABEL

(1) A label called "Model Label" is affixed in the location as indicated in (3) below. When using this parts catalogue, please be sure to cross-reference the "model code – production code No." in the catalogue with the "model code – production code No." indicated on the Model Label affixed onto the product concerned.

(2) "Model Label" Indication

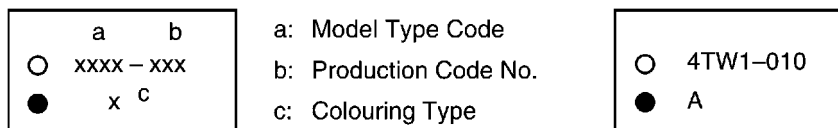

(3) Model Label Affixing Location

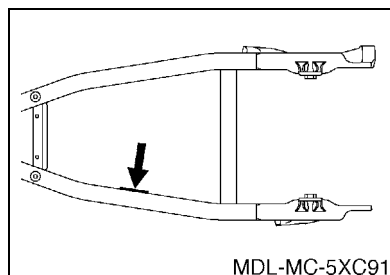

(4) Colouring Information

Model Code	Colouring Type Code	Colour Code	Colour Name	Abbreviation
5XC9	A	0583	DEEP PURPLISH BLUE SOLID E	DPBSE
5XCA	A	0583	DEEP PURPLISH BLUE SOLID E	DPBSE
5XCB	A	0583	DEEP PURPLISH BLUE SOLID E	DPBSE
5XCC	A	0583	DEEP PURPLISH BLUE SOLID E	DPBSE
5XCD	B	0386	LIGHT REDDISH YELLOW SOLID 1	LRY51
5XCE	B	0386	LIGHT REDDISH YELLOW SOLID 1	LRY51
5XCF	B	0386	LIGHT REDDISH YELLOW SOLID 1	LRY51

(5) Model Code – Production Code Number of Model Listed in This Parts Catalogue

Model Code	Production Code No.	Country (destination)	Model Code	Production Code No.	Country (destination)
5XC9	010	U.S.A.			
	020	CANADA			
5XCA	010	EUROPE 1			
	020	FRANCE			
5XCB	010	JAPAN			
5XCC	010	AUSTRALIA			
		NEW ZEALAND			
		SOUTH AFRICA			
5XCD	010	U.S.A.			
	020	CANADA			
5XCE	010	JAPAN			
5XCF	010	AUSTRALIA			
		NEW ZEALAND			
		SOUTH AFRICA			

CONTENTS

ENGINE

CYLINDER	B2
CRANKSHAFT & PISTON	B4
VALVE	B5
CAMSHAFT & CHAIN	B7
WATER PUMP	B8
RADIATOR & HOSE	B9
OIL PUMP	B10
OIL CLEANER	B12
INTAKE	B13
CARBURETOR	B14
EXHAUST	C5
CRANKCASE	C6
CRANKCASE COVER 1	C7
STARTER	C9
CLUTCH	C10
TRANSMISSION	C12
SHIFT CAM & FORK	C14
SHIFT SHAFT	C15

CHASSIS

FRAME	D2
FENDER	D4
SIDE COVER & OIL TANK	D6
REAR ARM	D8
REAR SUSPENSION	D10
STEERING	D12
FRONT FORK	D13
FUEL TANK	E2
SEAT	E4
FRONT WHEEL	E5
FRONT BRAKE CALIPER	E6
REAR WHEEL	E7
REAR BRAKE CALIPER	E9
STEERING HANDLE & CABLE	E10
FRONT MASTER CYLINDER	E11
STAND & FOOTREST	E12
REAR MASTER CYLINDER	E13
GENERATOR	E14
HANDLE SWITCH & LEVER	E15
ELECTRICAL 1	F2
ALTERNATE FOR CHASSIS	F3

INDEX

NUMERICAL INDEX	M1
-----------------------	----

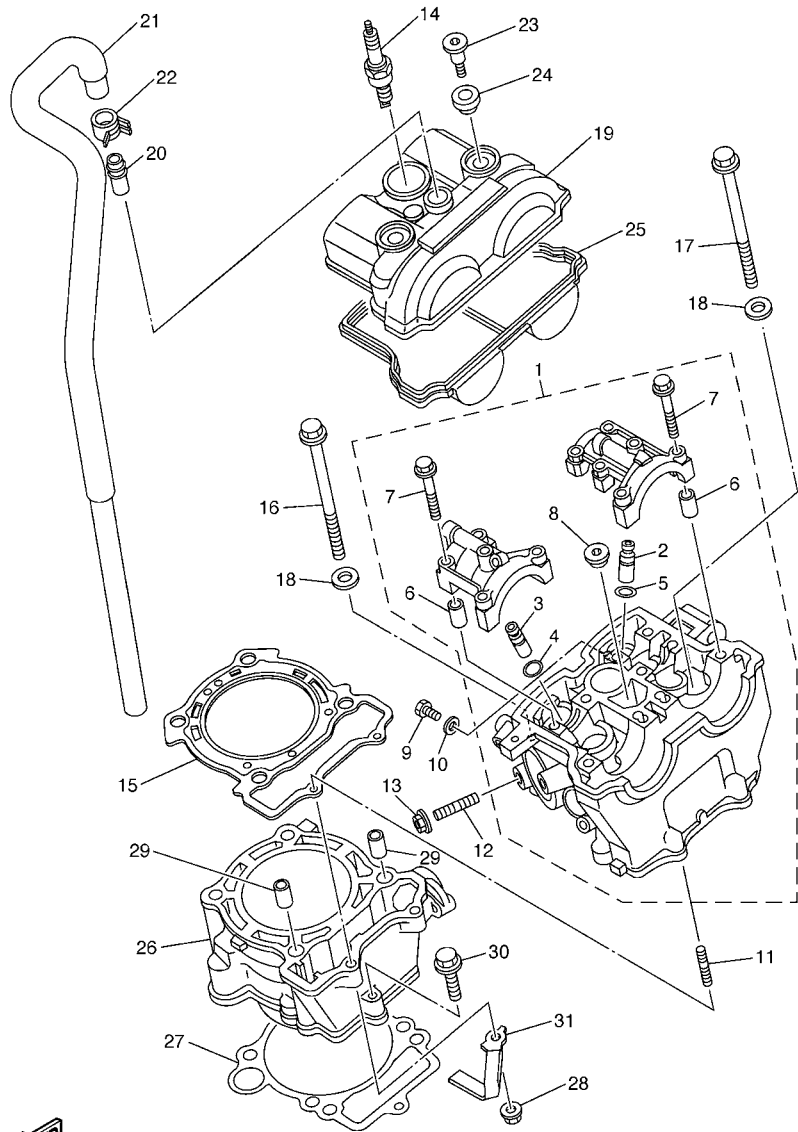

5XC9100-E010

FIG. 1 CYLINDER

REF. NO.	PART NO.	DESCRIPTION	NOA	EUR	JPN	ANZ	REMARKS
1	5XC-11102-10	CYLINDER HEAD ASSY	1	1	1	1	
2	5NL-11133-10	.GUIDE, VALVE 1	3	3	3	3	
3	5NL-11134-10	.GUIDE, VALVE 2	2	2	2	2	
4	93440-10153	.CIRCLIP	2	2	2	2	
5	93440-07149	.CIRCLIP	3	3	3	3	
6	91808-16023	.PIN, DOWEL	4	4	4	4	
7	90105-06027	.BOLT, FLANGE	10	10	10	10	
8	90340-12112	.PLUG, STRAIGHT SCREW	1	1	1	1	
9	95022-06010	BOLT, FLANGE	1	1	1	1	
10	90430-06014	GASKET	1	1	1	1	
11	90116-06541	BOLT, STUD	2	2	2	2	
12	95612-08620	BOLT, STUD	1	1	1	1	
13	95702-08500	NUT, FLANGE	1	1	1	1	
14	94701-00411	PLUG, SPARK (NGK R CR8E)	1	1		1	STD
	94703-00411	PLUG, SPARK (NGK R CR8E)			1		STD
	94701-00410	PLUG, SPARK (NGK R CR9E)	1	1		1	AP
	94703-00410	PLUG, SPARK (NGK R CR9E)			1		AP
15	5NL-11181-00	GASKET, CYLINDER HEAD 1	1	1	1	1	
16	90105-09004	BOLT, FLANGE	2	2	2	2	
17	90105-09002	BOLT, FLANGE	2	2	2	2	
18	90201-096J9	WASHER, PLATE	4	4	4	4	
19	5NL-11191-20	COVER, CYLINDER HEAD 1	1	1	1	1	
20	371-11167-01	PIPE, BREATHER 2	1	1	1	1	
21	5TA-11166-00	PIPE, BREATHER 1	1	1	1	1	
22	90467-14015	CLIP	1	1	1	1	
23	90109-066F0	BOLT	2	2	2	2	
24	4KG-1111G-00	RUBBER, MOUNT 1	2	2	2	2	

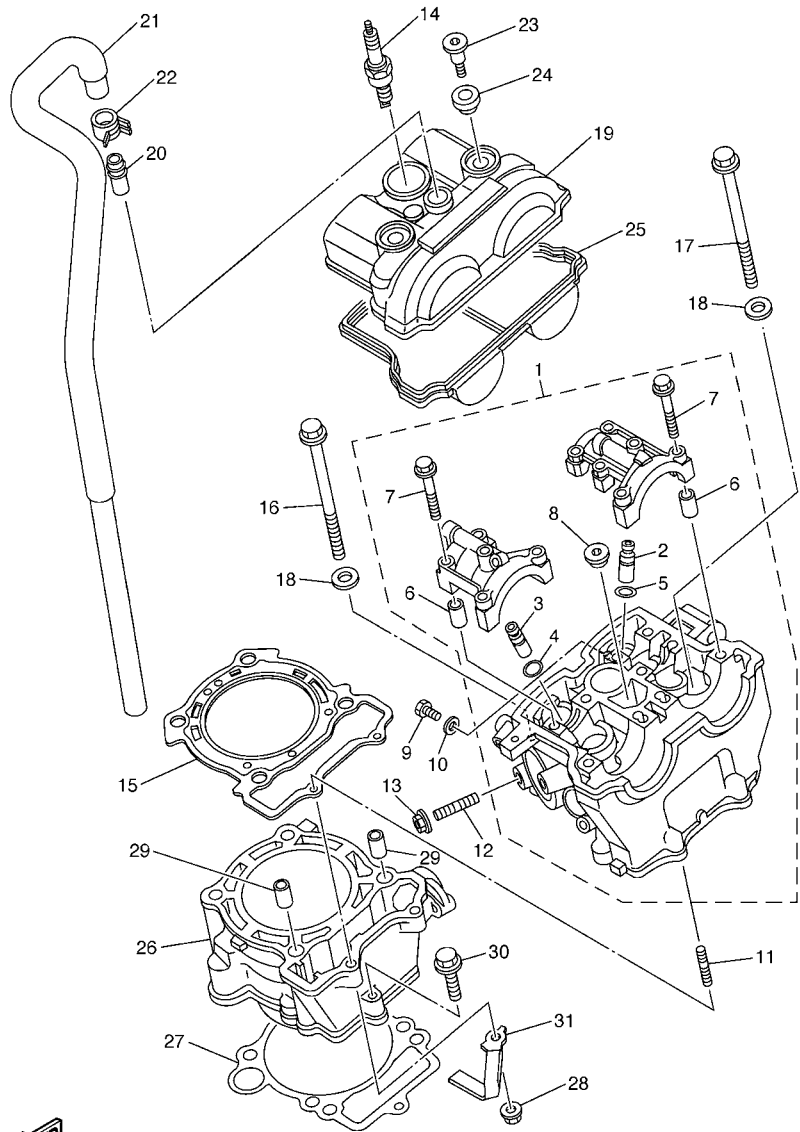

FIG. 1 CYLINDER

REF. NO.	PART NO.	DESCRIPTION	NOA	EUR	JPN	ANZ	REMARKS
25	5NL-11193-00	GASKET, HEAD COVER 1	1	1	1	1	
26	5XC-11311-01	CYLINDER 1	1	1	1	1	
27	5NL-11351-00	GASKET, CYLINDER	1	1	1	1	
28	95702-06500	NUT, FLANGE	2	2	2	2	
29	93612-16254	PIN, DOWEL	2	2	2	2	
30	95022-06035	BOLT, FLANGE	1	1	1	1	
31	5UM-11387-00	CLAMP, HOSE 1	1	1	1	1	



5XC9100-E010

FIG. 2 CRANKSHAFT & PISTON

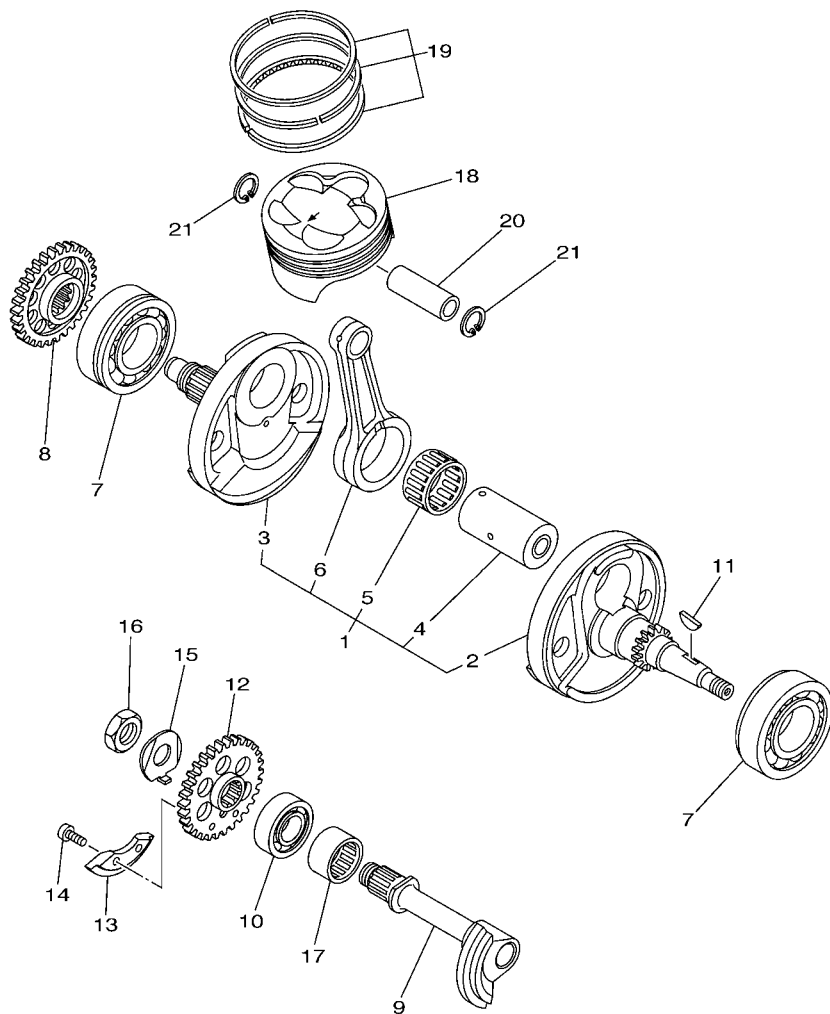

FWD
5NL1100-1020

REF. NO.	PART NO.	DESCRIPTION	NOA	EUR	JPN	ANZ	REMARKS
1	5XC-11400-10	CRANKSHAFT ASSY	1	1	1	1	
2	5UL-11412-10	.CRANK 1	1	1	1	1	
3	5UL-11422-00	.CRANK 2	1	1	1	1	
4	5XC-11681-00	.PIN, CRANK 1	1	1	1	1	
5	93310-63238	.BEARING	1	1	1	1	
6	5XC-11651-00	.ROD, CONNECTING	1	1	1	1	
7	93306-20648	BEARING	2	2	2	2	
8	5NL-11536-00	GEAR, DRIVE	1	1	1	1	
9	5NL-11455-00	SHAFT 1	1	1	1	1	
10	93306-20335	BEARING	1	1	1	1	
11	90280-03006	KEY, WOODRUFF	1	1	1	1	
12	5NL-11531-00	GEAR, BALANCE WEIGHT	1	1	1	1	
13	5NL-11454-00	WEIGHT 1	1	1	1	1	
14	90149-06250	SCREW	2	2	2	2	
15	90215-14204	WASHER, LOCK	1	1	1	1	
16	90170-14171	NUT	1	1	1	1	
17	93311-32261	BEARING	1	1	1	1	
18	5NL-11631-20	PISTON (STD)	1	1	1	1	
19	5NL-11603-00	PISTON RING SET (STD)	1	1	1	1	
20	5NL-11633-00	PIN, PISTON	1	1	1	1	
21	93420-16086	CIRCLIP	2	2	2	2	

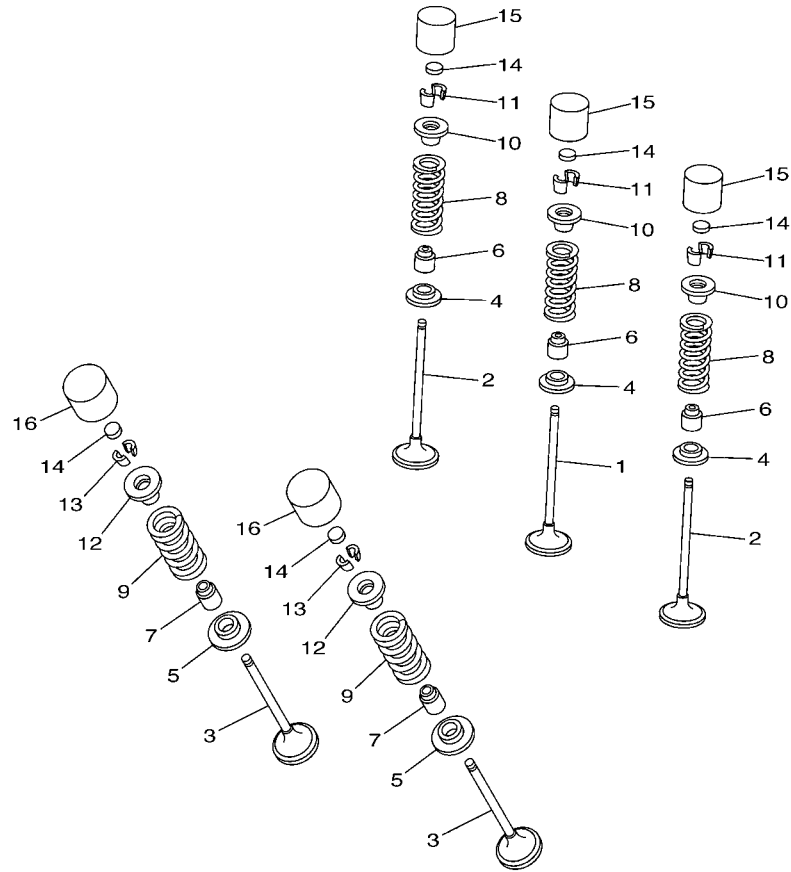

5NL1100-1030

FIG. 3 VALVE

REF. NO.	PART NO.	DESCRIPTION	NOA	EUR	JPN	ANZ	REMARKS
1	5NL-12111-10	VALVE, INTAKE	1	1	1	1	
2	5NL-12112-10	VALVE, INTAKE 2	2	2	2	2	
3	5NL-12121-10	VALVE, EXHAUST	2	2	2	2	
4	5NL-12116-00	SEAT, VALVE SPRING	3	3	3	3	
5	3GM-12126-00	SEAT, VALVE SPRING 2	2	2	2	2	
6	4TV-12119-00	SEAL, VALVE STEM	3	3	3	3	
7	4SV-12119-00	SEAL, VALVE STEM	2	2	2	2	
8	5NL-12113-00	SPRING, VALVE INNER	3	3	3	3	
9	5NL-12114-00	SPRING, VALVE OUTER	2	2	2	2	
10	1HX-12117-00	RETAINER, VALVE SPRING	3	3	3	3	
11	1HX-12118-00	COTTER, VALVE	6	6	6	6	
12	1WG-12117-00	RETAINER, VALVE SPRING	2	2	2	2	
13	1WG-12118-00	COTTER, VALVE	4	4	4	4	
14	1HX-12168-00	PAD, ADJUSTING 2 (1.20)	5	5	5	5	UR
	1HX-12168-20	PAD, ADJUSTING 2 (1.25)	5	5	5	5	UR
	1HX-12168-40	PAD, ADJUSTING 2 (1.30)	5	5	5	5	UR
	1HX-12168-60	PAD, ADJUSTING 2 (1.35)	5	5	5	5	UR
	1HX-12168-80	PAD, ADJUSTING 2 (1.40)	5	5	5	5	UR
	1HX-12168-A0	PAD, ADJUSTING 2 (1.45)	5	5	5	5	UR
	1HX-12168-F0	PAD, ADJUSTING 2 (1.50)	5	5	5	5	UR
	1HX-12168-H1	PAD, ADJUSTING 2 (1.55)	5	5	5	5	UR
	1HX-12168-K1	PAD, ADJUSTING 2 (1.60)	5	5	5	5	UR
	1HX-12168-M1	PAD, ADJUSTING 2 (1.65)	5	5	5	5	UR
	1HX-12168-R1	PAD, ADJUSTING 2 (1.70)	5	5	5	5	UR
	1HX-12168-U1	PAD, ADJUSTING 2 (1.75)	5	5	5	5	UR
	1HX-12168-W1	PAD, ADJUSTING 2 (1.80)	5	5	5	5	UR
	1HX-12168-Y1	PAD, ADJUSTING 2 (1.85)	5	5	5	5	UR

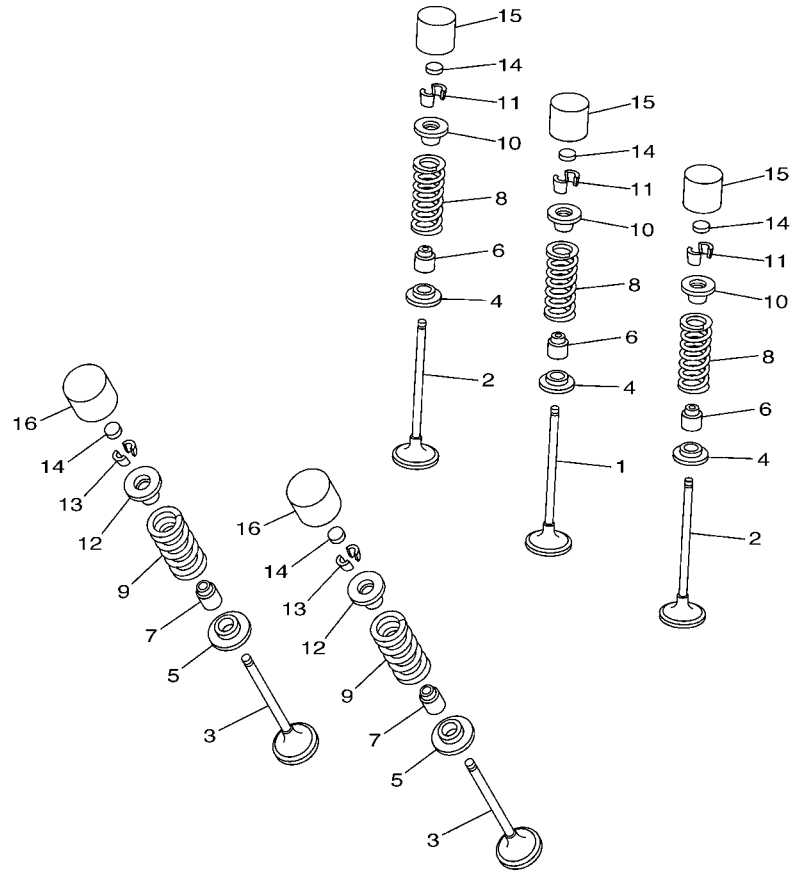

5NL1100-1030

FIG. 3 VALVE

REF. NO.	PART NO.	DESCRIPTION	NOA	EUR	JPN	ANZ	REMARKS
14	1HX-12169-11	PAD, ADJUSTING 2 (1.90)	5	5	5	5	UR
	1HX-12169-31	PAD, ADJUSTING 2 (1.95)	5	5	5	5	UR
	1HX-12169-50	PAD, ADJUSTING 2 (2.00)	5	5	5	5	UR
	1HX-12169-70	PAD, ADJUSTING 2 (2.05)	5	5	5	5	UR
	1HX-12169-90	PAD, ADJUSTING 2 (2.10)	5	5	5	5	UR
	1HX-12169-E0	PAD, ADJUSTING 2 (2.15)	5	5	5	5	UR
	1HX-12169-G0	PAD, ADJUSTING 2 (2.20)	5	5	5	5	UR
	1HX-12169-J0	PAD, ADJUSTING 2 (2.25)	5	5	5	5	UR
	1HX-12169-L0	PAD, ADJUSTING 2 (2.30)	5	5	5	5	UR
	1HX-12169-N0	PAD, ADJUSTING 2 (2.35)	5	5	5	5	UR
	1HX-12169-T0	PAD, ADJUSTING 2 (2.40)	5	5	5	5	UR
15	3LN-12153-10	LIFTER, VALVE	3	3	3	3	UR YELLOW
16	3FV-12153-10	LIFTER, VALVE	2	2	2	2	UR YELLOW

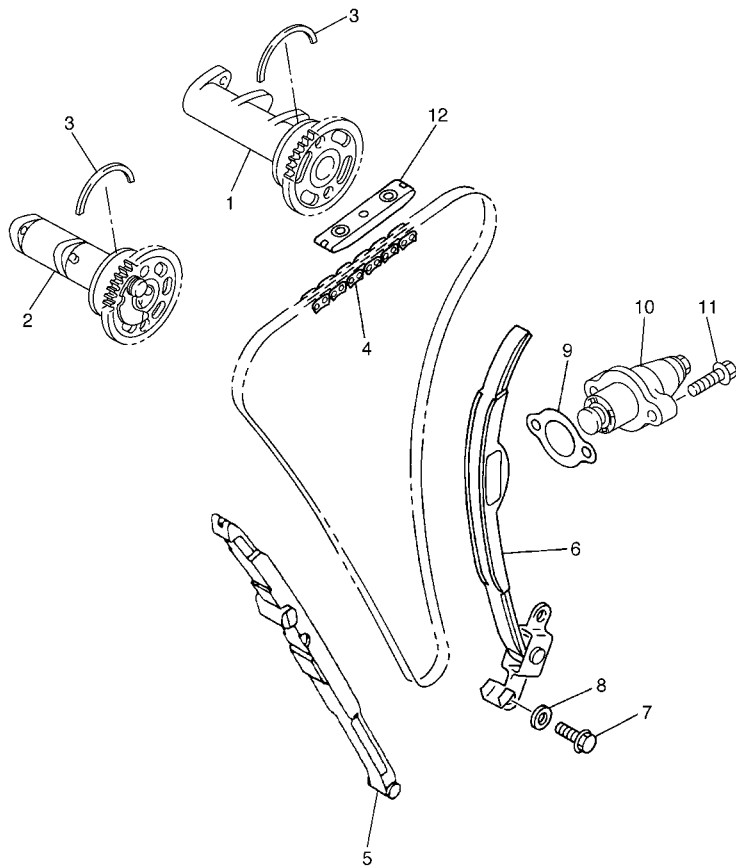
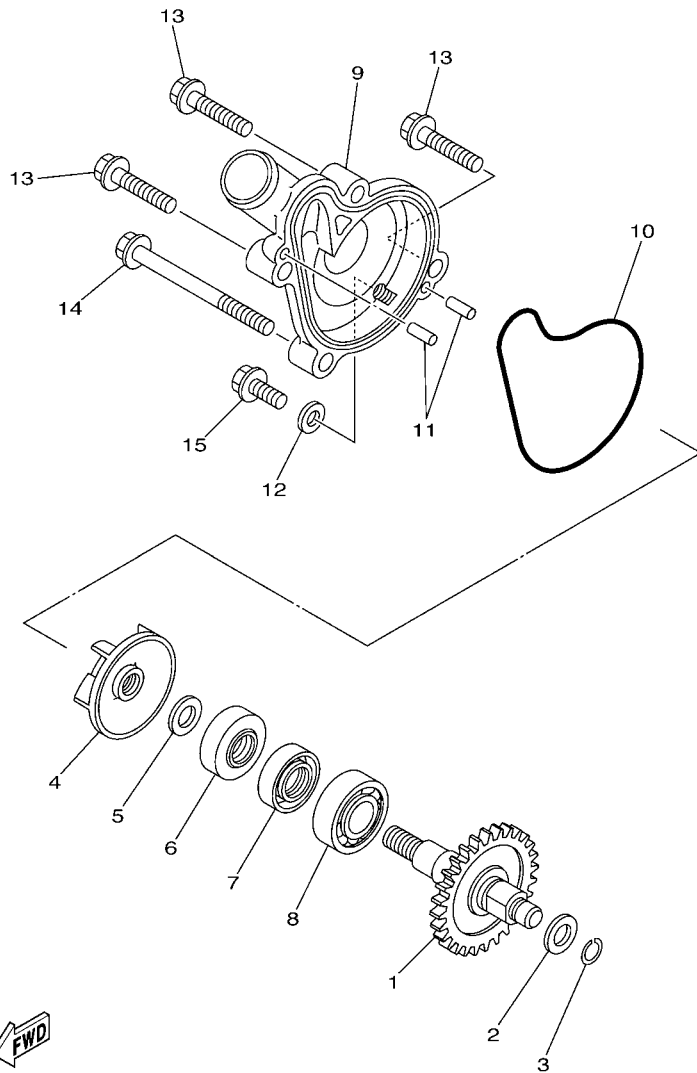

FIG. 4 CAMSHAFT & CHAIN

REF. NO.	PART NO.	DESCRIPTION	NOA	EUR	JPN	ANZ	REMARKS
1	5UL-12170-10	CAMSHAFT ASSY 1	1	1	1	1	
2	5UL-12180-10	CAMSHAFT ASSY 2	1	1	1	1	
3	93440-41178	CIRCLIP	2	2	2	2	
4	94591-53114	CHAIN	1	1	1	1	
5	5NL-12251-10	DAMPER, CHAIN 1	1	1	1	1	
6	5NL-12252-00	DAMPER, CHAIN 2	1	1	1	1	
7	97027-06016	BOLT	2	2	2	2	
8	92907-06600	WASHER, PLATE	2	2	2	2	
9	4FM-12213-00	GASKET, TENSIONER CASE	1	1	1	1	
10	5TA-12210-20	TENSIONER ASSY, CAM CHAIN	1	1	1	1	
11	95022-06025	BOLT, FLANGE	2	2	2	2	
12	5BE-12241-00	GUIDE, STOPPER 2	1	1	1	1	



5XC9100-E040



5NL1100-1050

FIG. 5 WATER PUMP

REF. NO.	PART NO.	DESCRIPTION	NOA	EUR	JPN	ANZ	REMARKS
1	5XC-12459-00	GEAR, IMPELLER SHAFT	1	1	1	1	
2	90201-08512	WASHER, PLATE	1	1	1	1	
3	93440-07182	CIRCLIP	1	1	1	1	
4	5DH-12451-00	IMPELLER, WATER PUMP	1	1	1	1	
5	90201-08512	WASHER, PLATE	1	1	1	1	
6	93109-11073	OIL SEAL	1	1	1	1	
7	93102-12106	OIL SEAL (SD 12-22-5 HS)	1	1	1	1	
8	93306-00105	BEARING	1	1	1	1	
9	5NL-12422-10	COVER, HOUSING	1	1	1	1	
10	5NL-12439-00	O-RING	1	1	1	1	
11	93604-10011	PIN, DOWEL	2	2	2	2	
12	90430-06014	GASKET	1	1	1	1	
13	95022-06025	BOLT, FLANGE	3	3	3	3	
14	95022-06065	BOLT, FLANGE	1	1	1	1	
15	95022-06012	BOLT, FLANGE	1	1	1	1	

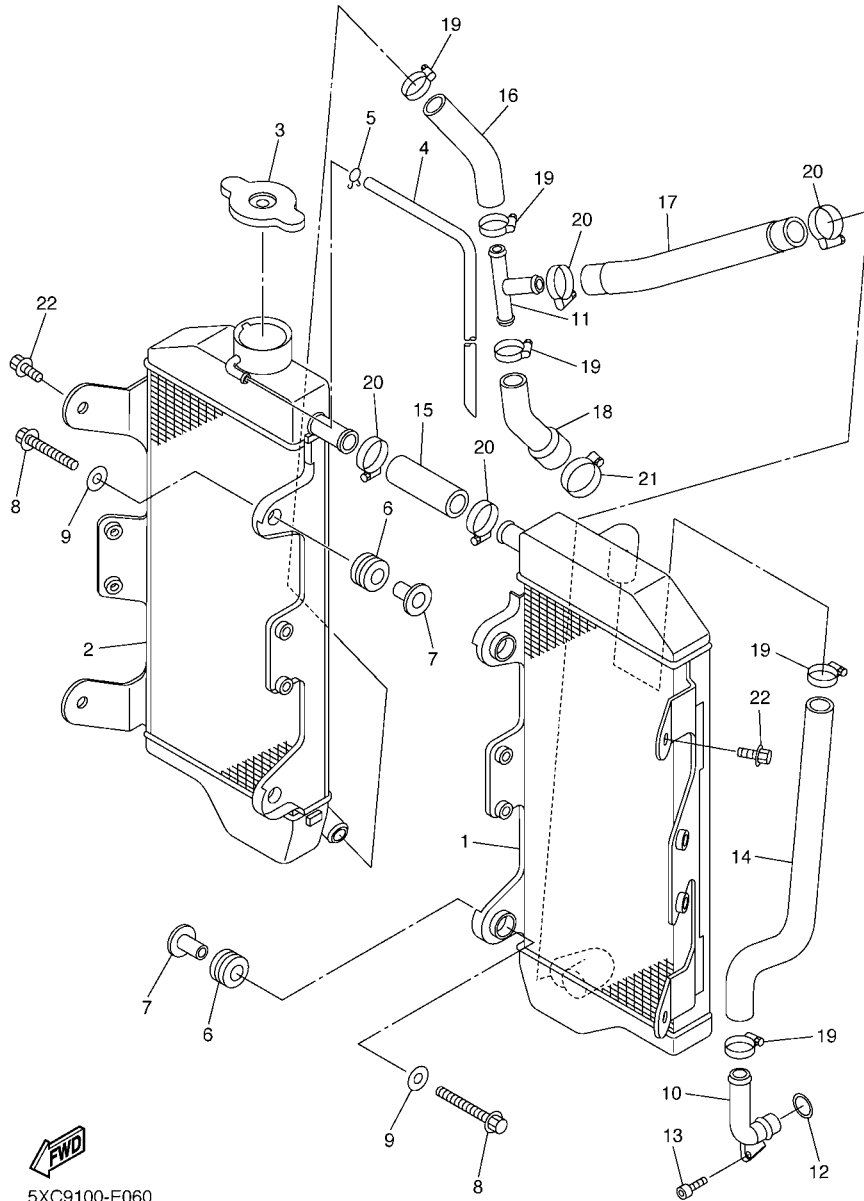

5XC9100-E060

FIG. 6 RADIATOR & HOSE

REF. NO.	PART NO.	DESCRIPTION	NOA	EUR	JPN	ANZ	REMARKS
1	5XC-1240A-90	RADIATOR ASSY	1	1	1	1	
2	5XC-12461-90	RADIATOR ASSY	1	1	1	1	
3	22W-12462-00	CAP, RADIATOR	1	1	1	1	
4	91A20-05065	TUBE, FLEXIBLE VINYL	1	1	1	1	
5	90467-090A2	CLIP	1	1	1	1	
6	90480-15528	GROMMET	4	4	4	4	
7	90387-06065	COLLAR	4	4	4	4	
8	95027-06030	BOLT, FLANGE	4	4	4	4	
9	90201-06571	WASHER, PLATE	4	4	4	4	
10	5XC-12481-90	PIPE 1	1	1	1	1	
11	5XC-12482-90	PIPE 2	1	1	1	1	
12	93210-15414	O-RING	1	1	1	1	
13	91312-06012	BOLT	1	1	1	1	
14	5XC-12576-90	HOSE 1	1	1	1	1	
15	1C3-12482-00	PIPE 2	1	1	1	1	
16	5XC-12578-90	HOSE 3	1	1	1	1	
17	5XC-12579-90	HOSE 4	1	1	1	1	
18	5XC-1244H-90	HOSE 5	1	1	1	1	
19	90450-25001	HOSE CLAMP ASSY	5	5	5	5	
20	90450-22001	HOSE CLAMP ASSY	4	4	4	4	
21	90450-32003	HOSE CLAMP ASSY	1	1	1	1	
22	95022-06010	BOLT, FLANGE	2	2	2	2	

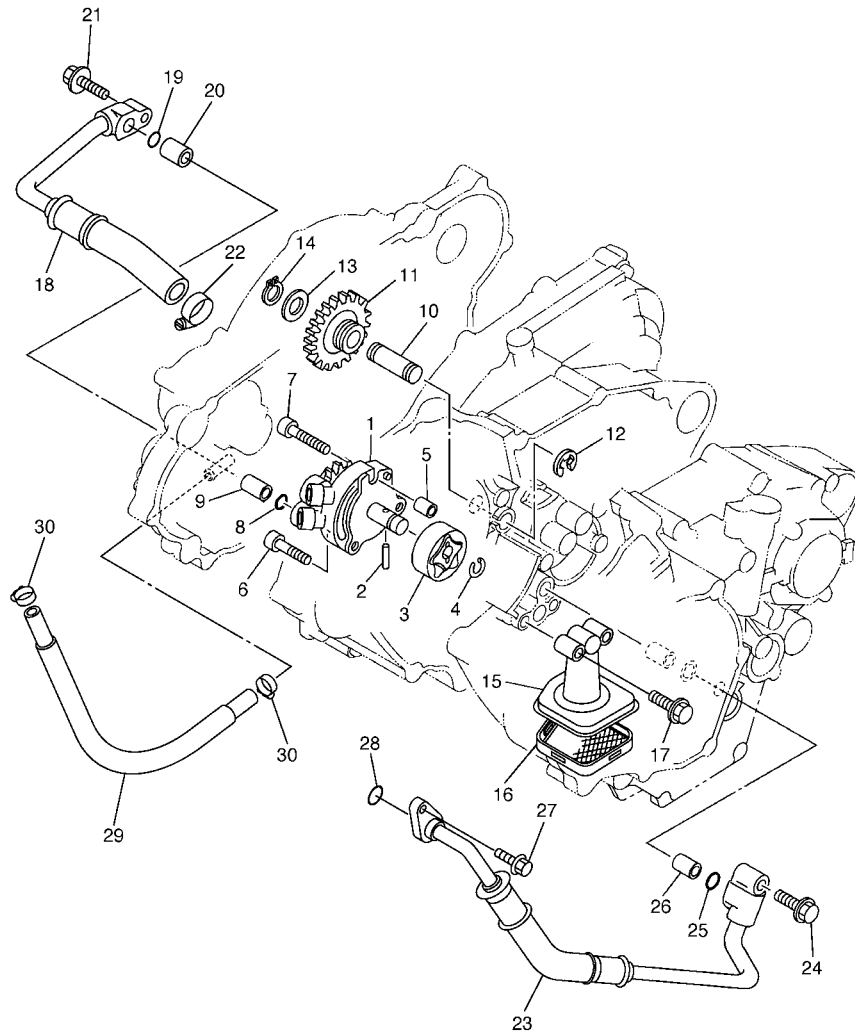

5XC9100-E070

FIG. 7 OIL PUMP

REF. NO.	PART NO.	DESCRIPTION	NOA	EUR	JPN	ANZ	REMARKS
1	5SG-13300-00	OIL PUMP ASSY	1	1	1	1	
2	93603-16219	PIN, DOWEL	1	1	1	1	
3	5NL-13320-00	ROTOR ASSY 2	1	1	1	1	
4	93440-10153	CIRCLIP	1	1	1	1	
5	99530-08012	PIN, DOWEL	1	1	1	1	
6	91312-06025	BOLT	2	2	2	2	
7	91317-06030	BOLT	1	1	1	1	
8	93210-10197	O-RING	1	1	1	1	
9	99530-10114	PIN, DOWEL	1	1	1	1	
10	5BE-13342-00	SHAFT, IDLE GEAR	1	1	1	1	
11	5NL-13341-00	GEAR, OIL PUMP IDLE	1	1	1	1	
12	99001-08600	CIRCLIP	1	1	1	1	
13	90201-12166	WASHER, PLATE	1	1	1	1	
14	99009-12400	CIRCLIP	1	1	1	1	
15	5XC-13412-00	HOUSING, STRAINER	1	1	1	1	
16	5NL-13411-00	STRAINER, OIL	1	1	1	1	
17	95022-06025	BOLT, FLANGE	2	2	2	2	
18	5XC-13464-10	HOSE, OIL 1	1	1	1	1	
19	93210-10197	O-RING	1	1	1	1	
20	99530-10114	PIN, DOWEL	1	1	1	1	
21	95022-06025	BOLT, FLANGE	1	1	1	1	
22	90450-22001	HOSE CLAMP ASSY	1	1	1	1	
23	5XC-13465-10	HOSE, OIL 2	1	1	1	1	
24	95022-06025	BOLT, FLANGE	1	1	1	1	
25	93210-10197	O-RING	1	1	1	1	
26	99530-10114	PIN, DOWEL	1	1	1	1	
27	95022-06016	BOLT, FLANGE	1	1	1	1	

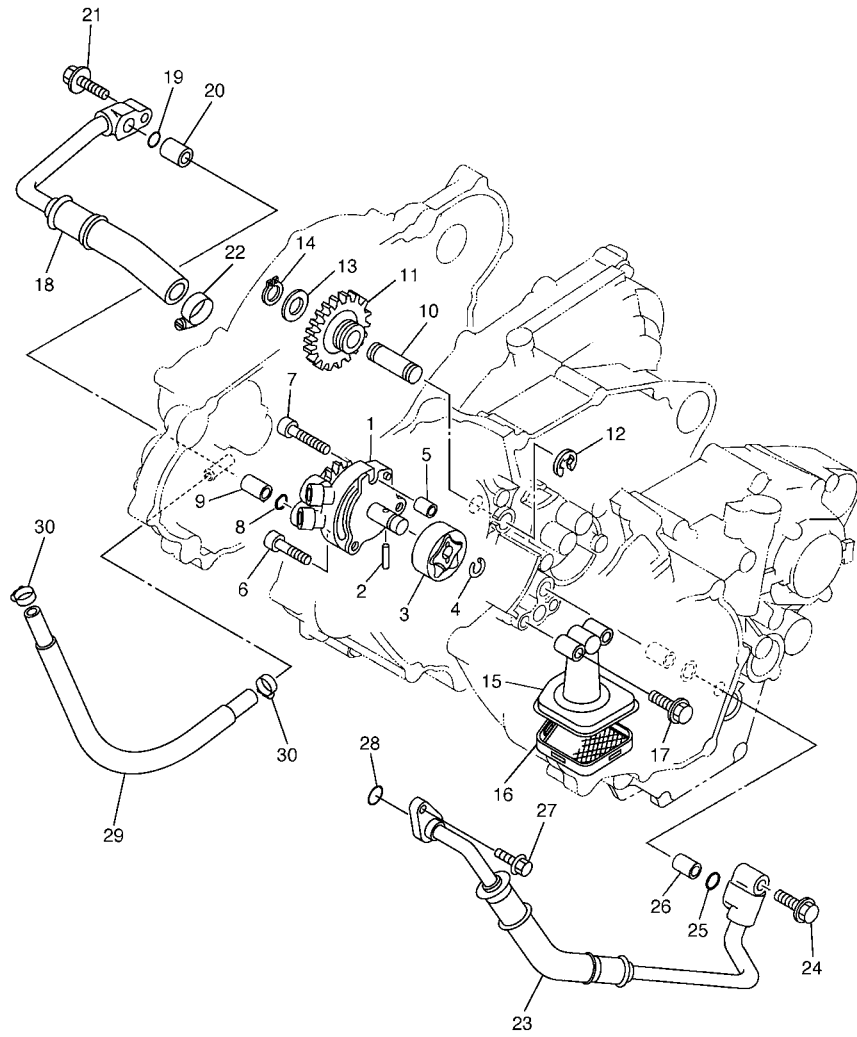

5XC9100-E070

FIG. 7 OIL PUMP

REF. NO.	PART NO.	DESCRIPTION	NOA	EUR	JPN	ANZ	REMARKS
28	93210-09754	O-RING	1	1	1	1	
29	90445-14010	HOSE	1	1	1	1	
30	90450-17001	HOSE CLAMP ASSY	2	2	2	2	

FIG. 8 OIL CLEANER

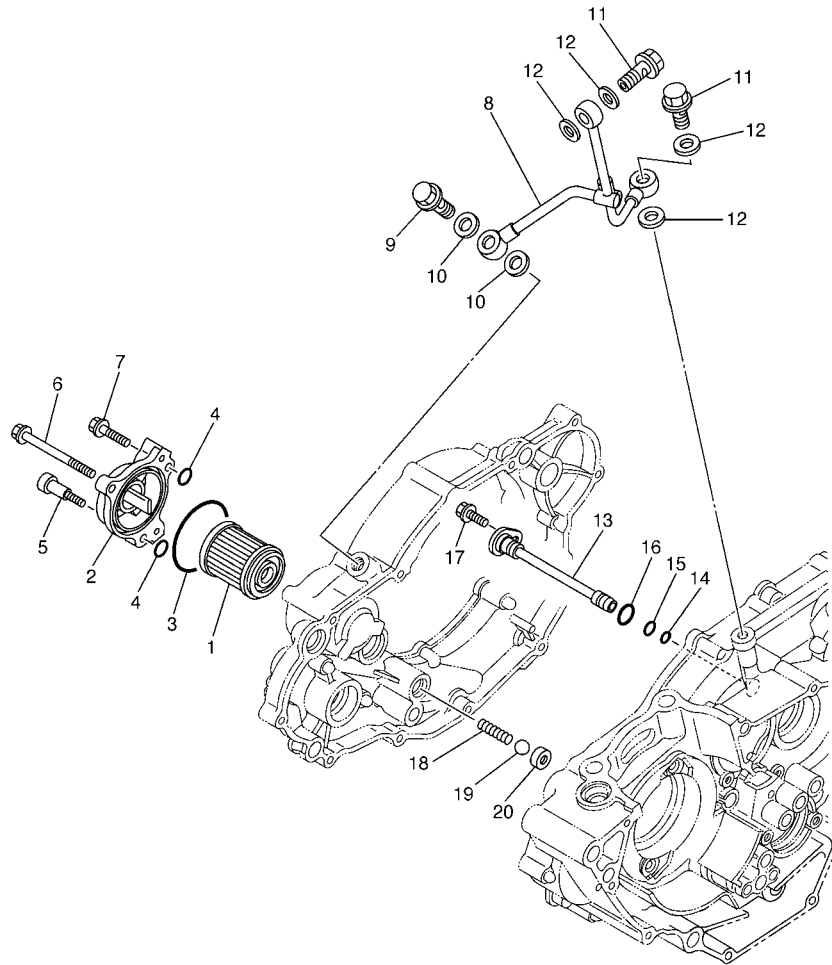

REF. NO.	PART NO.	DESCRIPTION	NOA	EUR	JPN	ANZ	REMARKS
1	5TA-13440-00	ELEMENT ASSY, OIL CLEANER	1	1	1	1	
2	5BE-13447-10	COVER, OIL ELEMENT	1	1	1	1	
3	93210-47675	O-RING	1	1	1	1	
4	93210-07135	O-RING	3	3	3	3	
5	90110-06228	BOLT, HEXAGON SOCKET HEAD	1	1	1	1	
6	91312-06065	BOLT	1	1	1	1	
7	91312-06025	BOLT	1	1	1	1	
8	5NL-13161-10	PIPE, DELIVERY 1	1	1	1	1	
9	90401-10015	BOLT, UNION	1	1	1	1	
10	90430-10188	GASKET	2	2	2	2	
11	90401-08006	BOLT, UNION	2	2	2	2	
12	90430-08119	GASKET	4	4	4	4	
13	5NL-13171-00	PIPE, DELIVERY 2	1	1	1	1	
14	93210-07003	O-RING	1	1	1	1	
15	93210-09008	O-RING	1	1	1	1	
16	93210-12759	O-RING	1	1	1	1	
17	95027-06012	BOLT, FLANGE	1	1	1	1	
18	90501-043E0	SPRING, COMPRESSION	1	1	1	1	
19	93503-08007	BALL	1	1	1	1	
20	583-13113-00	SEAT, CHECK BALL	1	1	1	1	



5XC9100-E080

FIG. 9 INTAKE

REF. NO.	PART NO.	DESCRIPTION	NOA	EUR	JPN	ANZ	REMARKS
1	5XC-13597-10	JOINT, CARBURETOR 3	1	1	1	1	
2	90450-57010	HOSE CLAMP ASSY	1	1	1	1	
3	90450-54002	HOSE CLAMP ASSY	1	1	1	1	
4	5TA-14293-00	COVER 1	1	1	1	1	
5	5TA-14227-00	GASKET	1	1	1	1	
6	5TA-14239-00	SEAL	1	1	1	1	
7	5TA-14987-00	HOSE	1	1	1	1	
8	3TJ-14137-40	CLIP	1	1	1	1	
9	5TA-14428-00	BOLT	2	2	2	2	
10	90450-61002	HOSE CLAMP ASSY	1	1	1	1	
11	5XC-14401-90	AIR CLEANER CASE ASSY	1	1	1	1	
12	5XC-14453-90	JOINT, AIR CLEANER 1	1	1	1	1	
13	5NY-14459-00	HOLDER, GUIDE	1	1	1	1	
14	5NY-14455-10	BAND	1	1	1	1	
15	5NY-14442-00	SPACER	1	1	1	1	
16	5XC-14417-90	COVER 1	1	1	1	1	
17	90267-32070	RIVET, BLIND	3	3	3	3	
18	90201-03313	WASHER, PLATE	6	6	6	6	
19	4XM-14451-00	ELEMENT, AIR CLEANER	1	1	1	1	
20	90209-06096	WASHER	1	1	1	1	
21	90122-06005	BOLT, WING	1	1	1	1	
22	5BE-14458-00	GUIDE	1	1	1	1	
23	90109-067F4	BOLT	2	2	2	2	

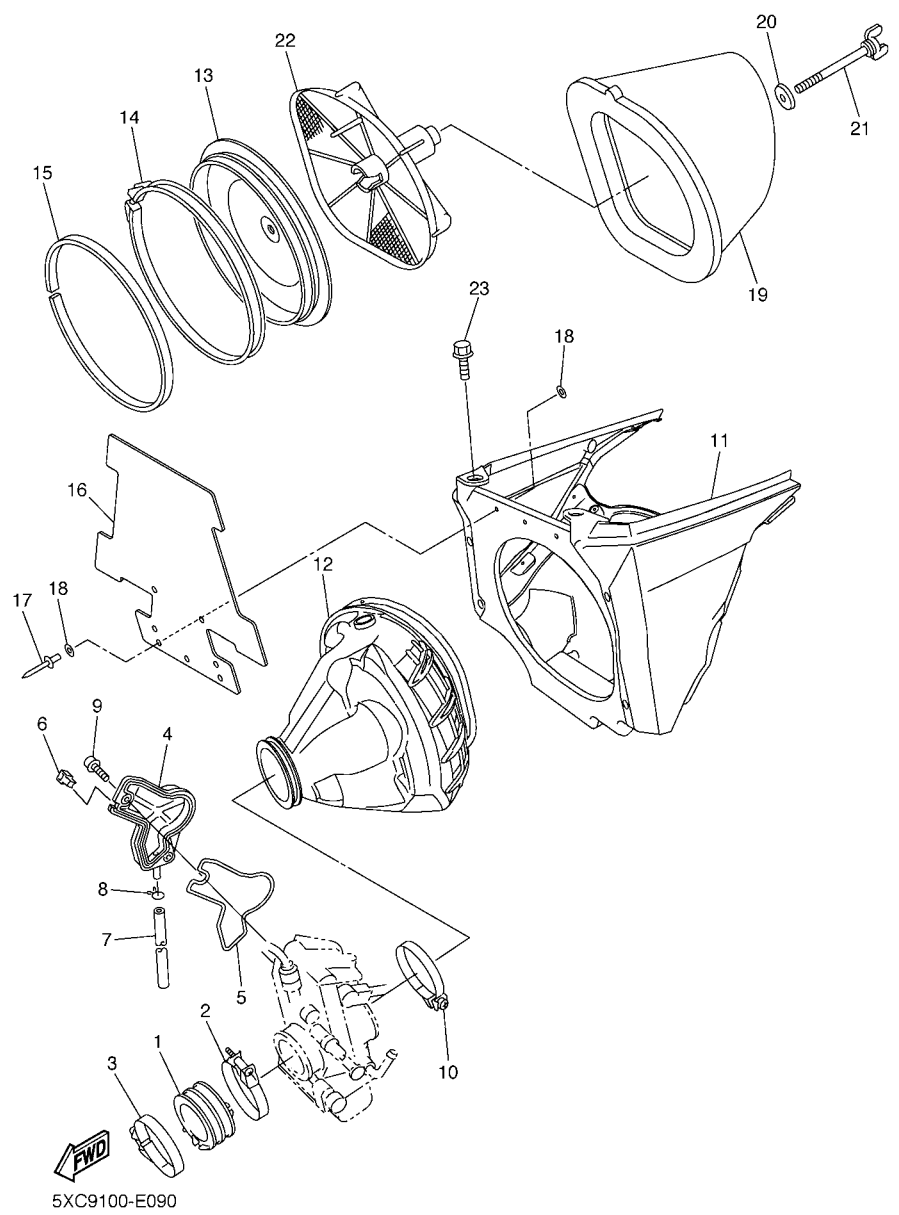

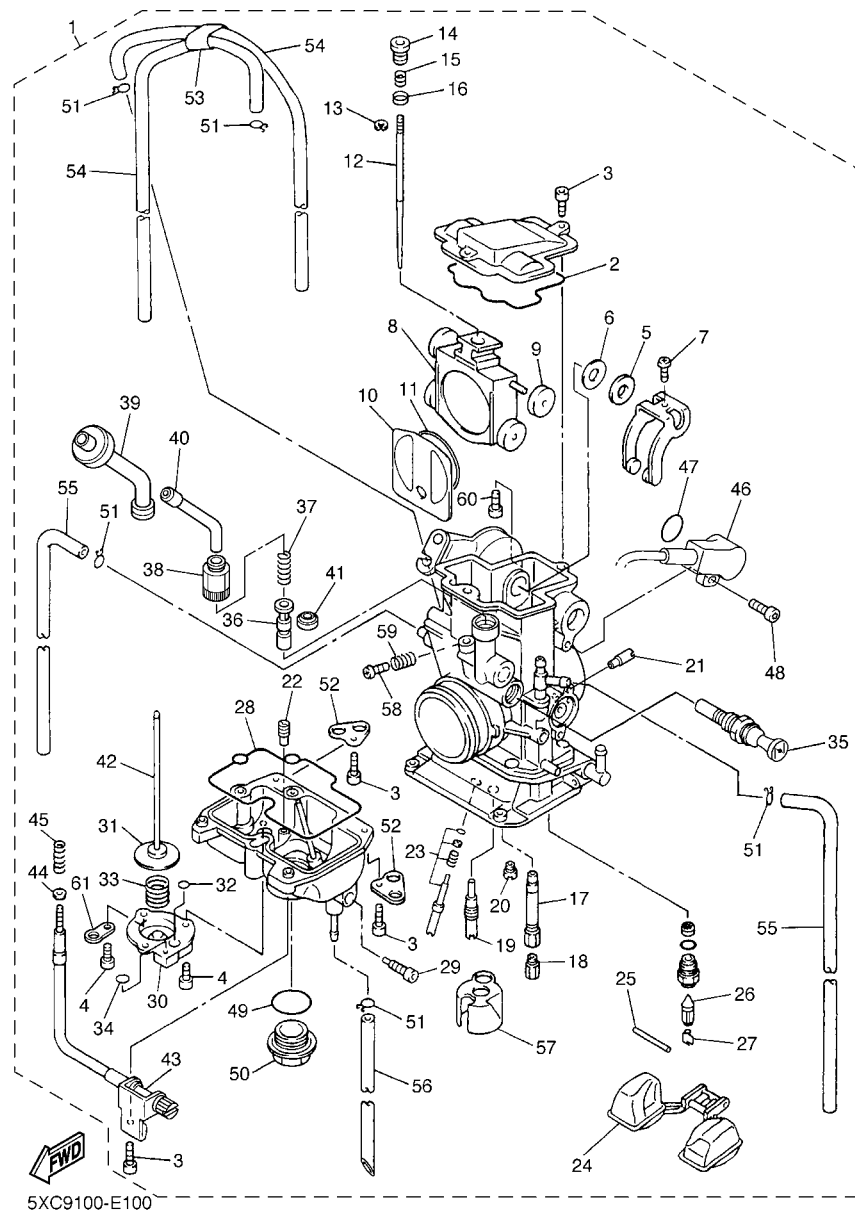

5XC9100-E100

FIG. 10 CARBURETOR

REF. NO.	PART NO.	DESCRIPTION	NOA	EUR	JPN	ANZ	REMARKS
1	5XC-14101-90	CARBURETOR ASSY 1	1				
	5XC-14101-A0	CARBURETOR ASSY 1		1	1	1	
2	5JG-14959-00	.GASKET	1	1	1	1	
3	91316-04012	.BOLT	6	6	6	6	
4	688-14592-00	.SCREW	3	3	3	3	
5	90202-08045	.WASHER, PLATE	1	1	1	1	
6	5JG-14951-00	.WASHER	1	1	1	1	
7	5JG-14522-00	.SCREW, ADJUST	1	1	1	1	
8	5JG-14388-10	.VALVE, VACUUM CONTROL	1	1	1	1	
9	3TJ-14267-40	.ROLLER	1	1	1	1	
10	5JG-14546-01	.VALVE, NEEDLE	1	1	1	1	
11	4FN-14997-00	.SEAL	1	1	1	1	
12	5NL-14916-E1	.NEEDLE (#OBELQ)	1				STD
	5JG-14916-EP	.NEEDLE (#OBEKP)		1	1	1	STD
	5NL-14916-EM	.NEEDLE (#OBELM)	1				AP
	5NL-14916-EN	.NEEDLE (#OBELN)	1				AP
	5NL-14916-EP	.NEEDLE (#OBELP)	1				AP
	5NL-14916-ER	.NEEDLE (#OBELR)	1				AP
	5NL-14916-ES	.NEEDLE (#OBELS)	1				AP
	5NL-14916-ET	.NEEDLE (#OBELT)	1				AP
	5JG-14916-EL	.NEEDLE (#OBEKL)		1	1	1	AP
	5JG-14916-EM	.NEEDLE (#OBEKM)		1	1	1	AP
	5JG-14916-EN	.NEEDLE (#OBEKN)		1	1	1	AP
	5JG-14916-E1	.NEEDLE (#OBEKQ)		1	1	1	AP
	5JG-14916-ER	.NEEDLE (#OBEKR)		1	1	1	AP
	5JG-14916-ES	.NEEDLE (#OBEKS)		1	1	1	AP
13	3TJ-14159-40	.CLIP	1	1	1	1	

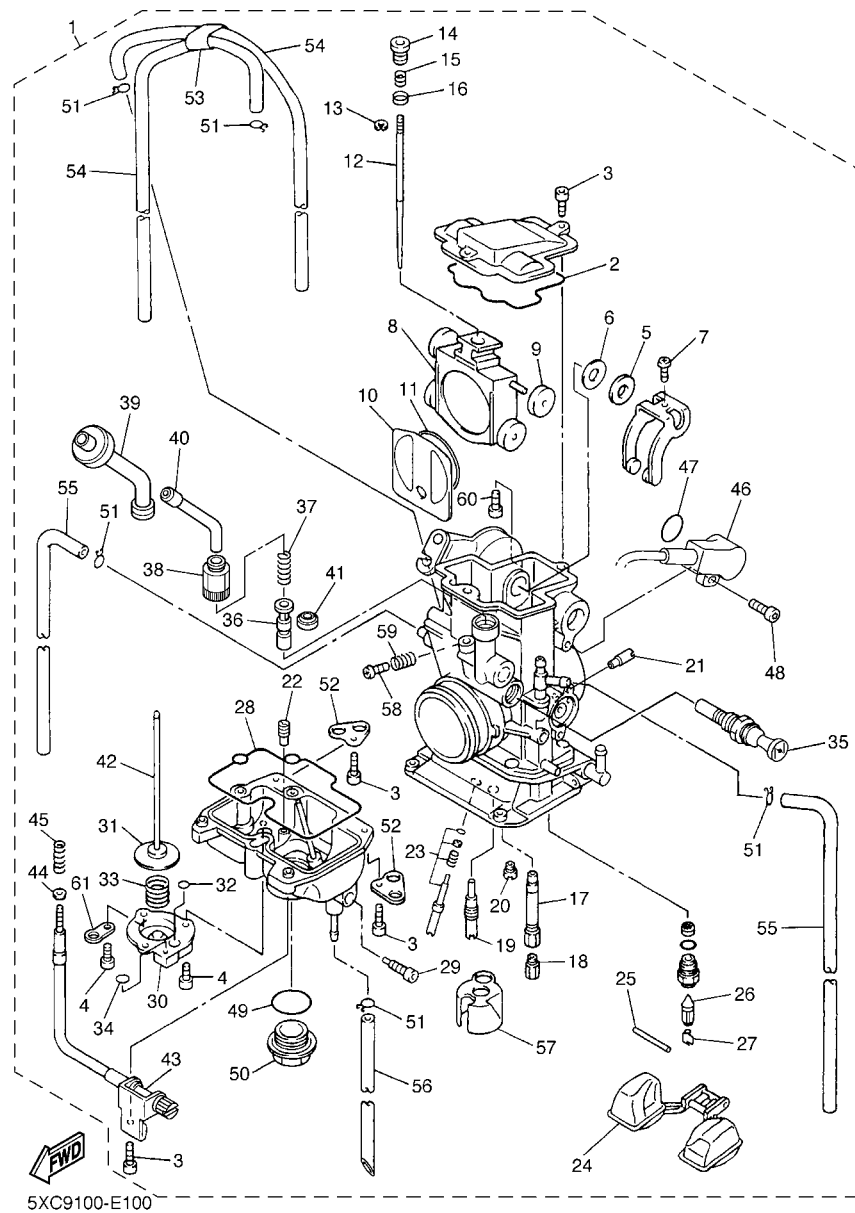

5XC9100-E100

FIG. 10 CARBURETOR

REF. NO.	PART NO.	DESCRIPTION	NOA	EUR	JPN	ANZ	REMARKS
14	5JG-14521-00	.SCREW, ADJUST	1	1	1	1	
15	5JG-14275-00	.SPRING	1	1	1	1	
16	5JG-14264-00	.COLLAR	1	1	1	1	
17	5JG-14947-00	.NOZZLE, MAIN	1	1	1	1	
18	4MX-14943-93	.JET, MAIN (#178)	1				STD
	4MX-14943-42	.JET, MAIN (#175)		1	1	1	STD
	4MX-14943-40	.JET, MAIN (#165)	1	1	1	1	AP
	4MX-14943-91	.JET, MAIN (#168)	1	1	1	1	AP
	4MX-14943-41	.JET, MAIN (#170)	1	1	1	1	AP
	4MX-14943-92	.JET, MAIN (#172)	1	1	1	1	AP
	4MX-14943-42	.JET, MAIN (#175)	1				AP
	4MX-14943-93	.JET, MAIN (#178)		1	1	1	AP
	4MX-14943-43	.JET, MAIN (#180)	1	1	1	1	AP
	4MX-14943-94	.JET, MAIN (#182)	1	1	1	1	AP
	4MX-14943-44	.JET, MAIN (#185)	1	1	1	1	AP
	4MX-14943-95	.JET, MAIN (#188)	1	1	1	1	AP
19	4MX-14948-04	.JET, SLOW (#42)	1	1	1	1	STD
	4MX-14948-02	.JET, SLOW (#38)	1	1	1	1	AP
	4MX-14948-03	.JET, SLOW (#40)	1	1	1	1	AP
	4MX-14948-05	.JET, SLOW (#45)	1	1	1	1	AP
	4MX-14948-06	.JET, SLOW (#48)	1	1	1	1	AP
20	3TJ-1494F-16	.JET (#72)	1	1	1	1	STD
	3TJ-1494F-13	.JET (#65)	1	1	1	1	AP
	3TJ-1494F-14	.JET (#68)	1	1	1	1	AP
	3TJ-1494F-15	.JET (#70)	1	1	1	1	AP
	3TJ-1494F-17	.JET (#75)	1	1	1	1	AP
	3TJ-1494F-18	.JET (#78)	1	1	1	1	AP

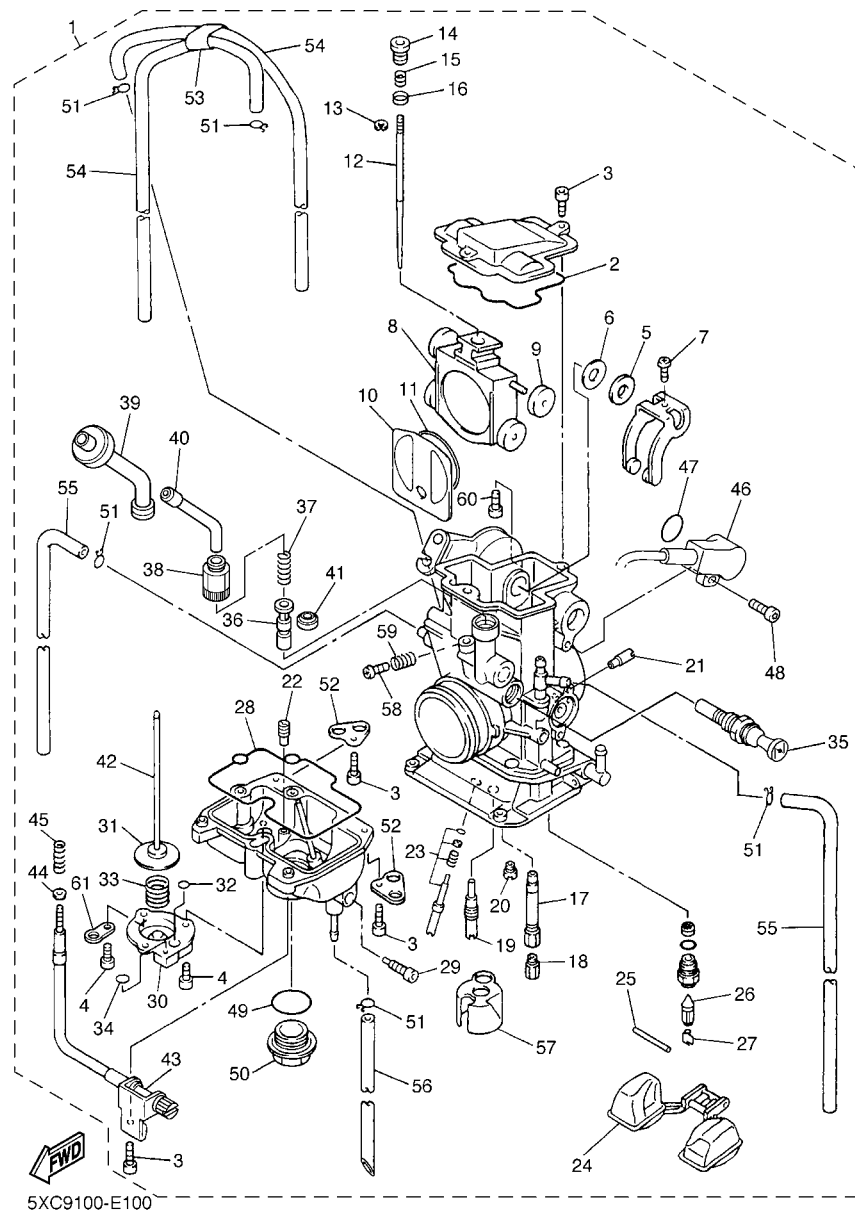

5XC9100-E100

FIG. 10 CARBURETOR

REF. NO.	PART NO.	DESCRIPTION	NOA	EUR	JPN	ANZ	REMARKS
20	3TJ-1494F-19	.JET (#80)	1	1	1	1	AP
21	5TA-14943-28	.JET, MAIN (#105)	1	1	1	1	
22	4JT-1494F-19	.JET (#80)	1				STD
	4JT-1494F-21	.JET (#85)		1	1	1	STD
	4JT-1494F-07	.JET (#50)	1				AP
<hr/>							
	4JT-1494F-09	.JET (#55)		1	1	1	AP
	4JT-1494F-11	.JET (#60)	1				AP
	4JT-1494F-13	.JET (#65)		1	1	1	AP
	4JT-1494F-15	.JET (#70)	1				AP
	4JT-1494F-17	.JET (#75)		1	1	1	AP
<hr/>							
	4JT-1494F-23	.JET (#90)	1				AP
	4JT-1494F-25	.JET (#95)		1	1	1	AP
	4JT-1494F-27	.JET (#100)	1				AP
	4JT-1494F-28	.JET (#105)		1	1	1	AP
	4JT-1494F-29	.JET (#110)	1				AP
<hr/>							
	4JT-1494F-30	.JET (#115)		1	1	1	AP
23	5NL-14105-00	.PILOT SCREW SET	1	1	1	1	
24	4SR-14985-00	.FLOAT	1	1	1	1	
25	676-14548-00	.PIN, FLOAT ARM	1	1	1	1	
26	4MX-14392-00	.VALVE, NEEDLE	1	1	1	1	
<hr/>							
27	633-14159-00	.CLIP	1	1	1	1	
28	5JG-14984-00	.GASKET, FLOAT CHAMBER	1	1	1	1	
29	3TJ-14191-40	.PLUG, DRAIN	1	1	1	1	
30	3TJ-14293-40	.COVER 1	1	1	1	1	
31	5JG-14940-76	.DIAPHRAGM ASSY	1	1	1	1	STD
<hr/>							
	5JG-14940-16	.DIAPHRAGM ASSY	1	1	1	1	AP
	5JG-14940-17	.DIAPHRAGM ASSY	1	1	1	1	AP

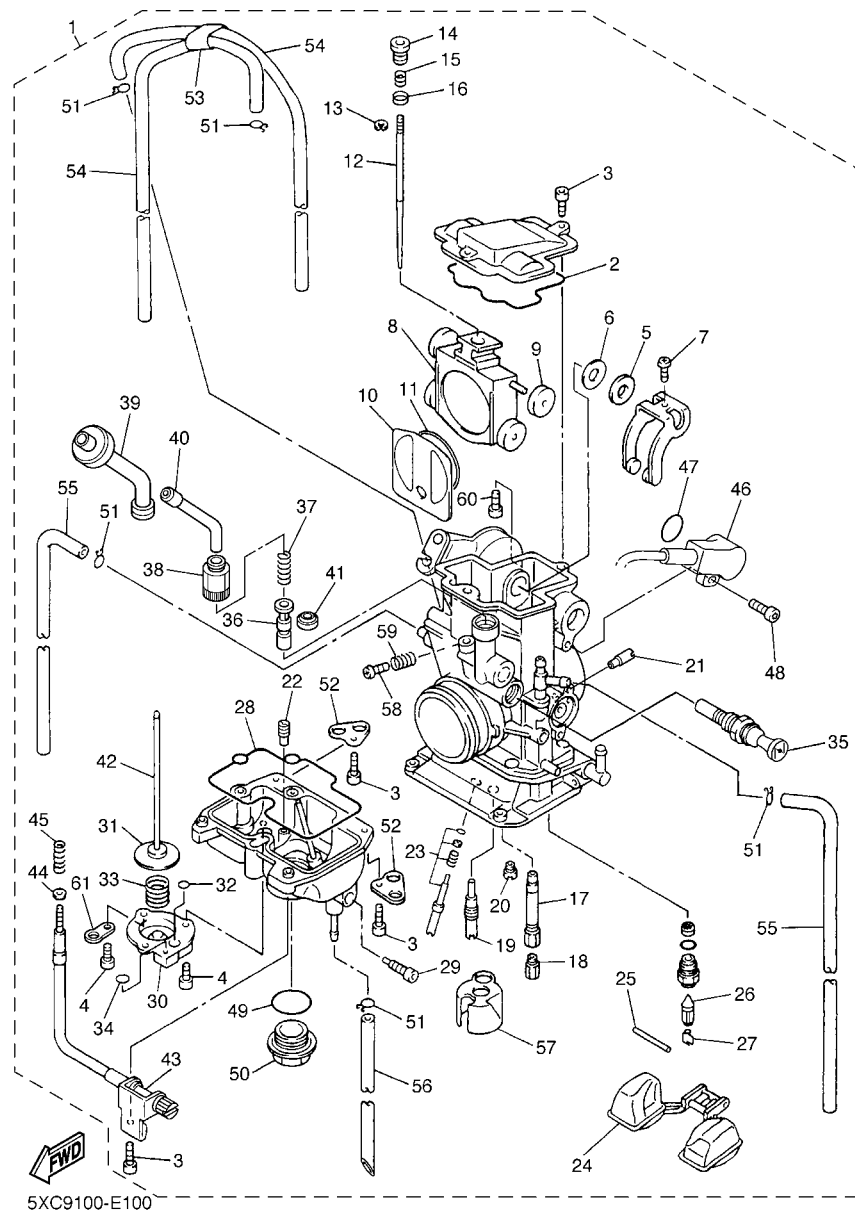

5XC9100-E100

FIG. 10 CARBURETOR

REF. NO.	PART NO.	DESCRIPTION	NOA	EUR	JPN	ANZ	REMARKS
31	5JG-14940-18	.DIAPHRAGM ASSY	1	1	1	1	AP
32	3TJ-14536-40	.GASKET	1	1	1	1	
33	3TJ-14933-40	.SPRING, DIAPHRAGM	1	1	1	1	
34	6H4-14561-00	.O-RING	1	1	1	1	
35	5XC-14171-00	.PLUNGER, STARTER	1	1	1	1	
36	5TA-14371-00	.PLUNGER, STARTER	1	1	1	1	
37	5TA-14335-00	.SPRING, PLUNGER	1	1	1	1	
38	5TA-14991-00	.SCREW	1	1	1	1	
39	5TA-14374-00	.CAP, PLUNGER	1	1	1	1	
40	5TA-14155-00	.GUIDE, CABLE	1	1	1	1	
41	5TA-14997-00	.SEAL	1	1	1	1	
42	5JG-14379-00	.ROD, STARTER	1	1	1	1	
43	5XC-14922-00	.SCREW, THROTTLE	1	1	1	1	
44	90201-08410	.WASHER, PLATE	1	1	1	1	
45	5TA-14934-00	.SPRING, THROTTLE STOP	1	1	1	1	
46	5XC-85885-00	.THROTTLE SENSOR ASSY	1	1	1	1	
47	5NX-14562-00	.O-RING	1	1	1	1	
48	5NX-14216-00	.SCREW	1	1	1	1	
49	4MX-14561-00	.O-RING	1	1	1	1	
50	4MX-14115-00	.PLUG, SCREW	1	1	1	1	
51	3TJ-14137-40	.CLIP	5	5	5	5	
52	5BE-14146-00	.PLATE	2	2	2	2	
53	5TA-14261-00	.HOLDER	1	1	1	1	
54	5UL-14196-00	.PIPE	2	2	2	2	
55	5TA-14197-00	.PIPE	2	2	2	2	
56	5TJ-14987-00	.HOSE	1	1	1	1	
57	5JG-14346-00	.PLATE	1	1	1	1	

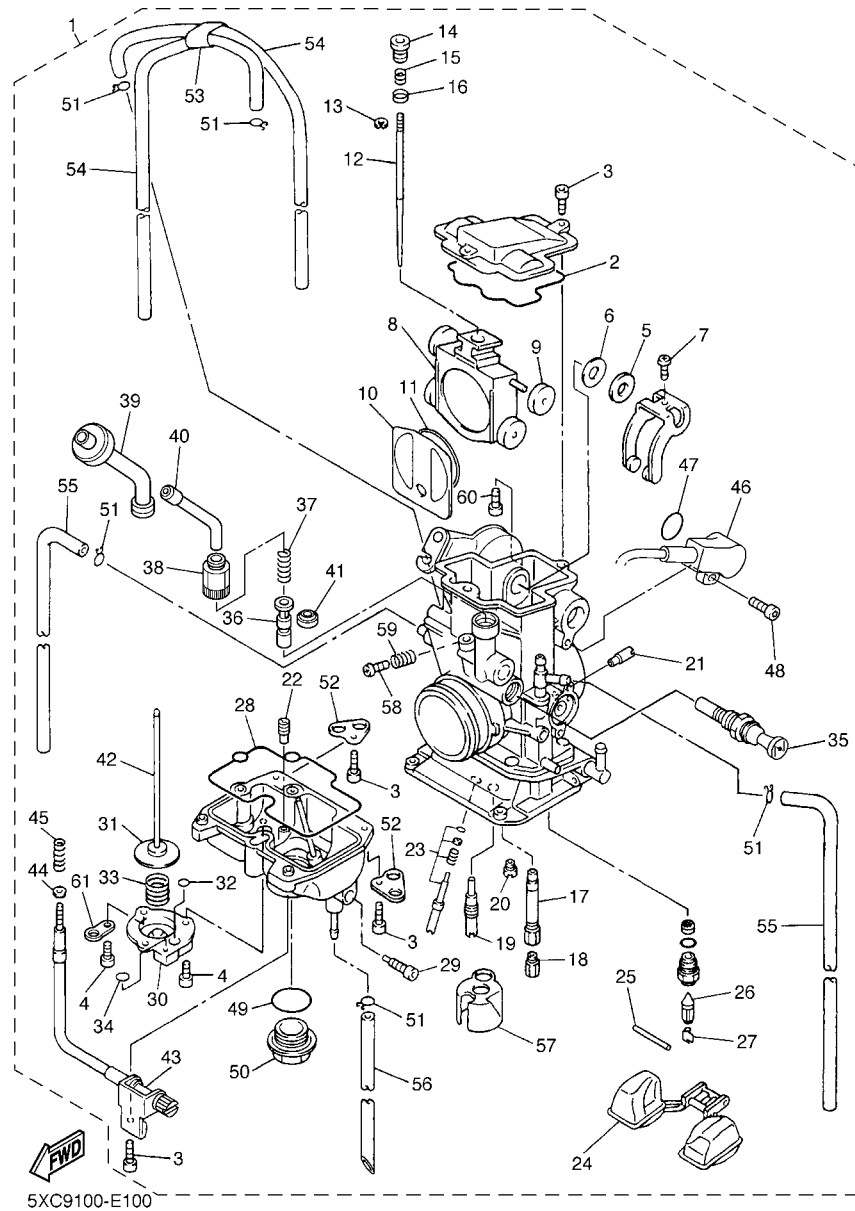

5XC9100-E100

FIG. 10 CARBURETOR

REF. NO.	PART NO.	DESCRIPTION	NOA	EUR	JPN	ANZ	REMARKS
58	5JG-14565-00	.SCREW	1	1	1	1	
59	5JG-14531-00	.SPRING, ADJUST SCREW	1	1	1	1	
60	5NL-14591-00	.SCREW	1	1	1	1	
61	5PA-14146-00	.PLATE	1	1	1	1	

FIG. 11 EXHAUST

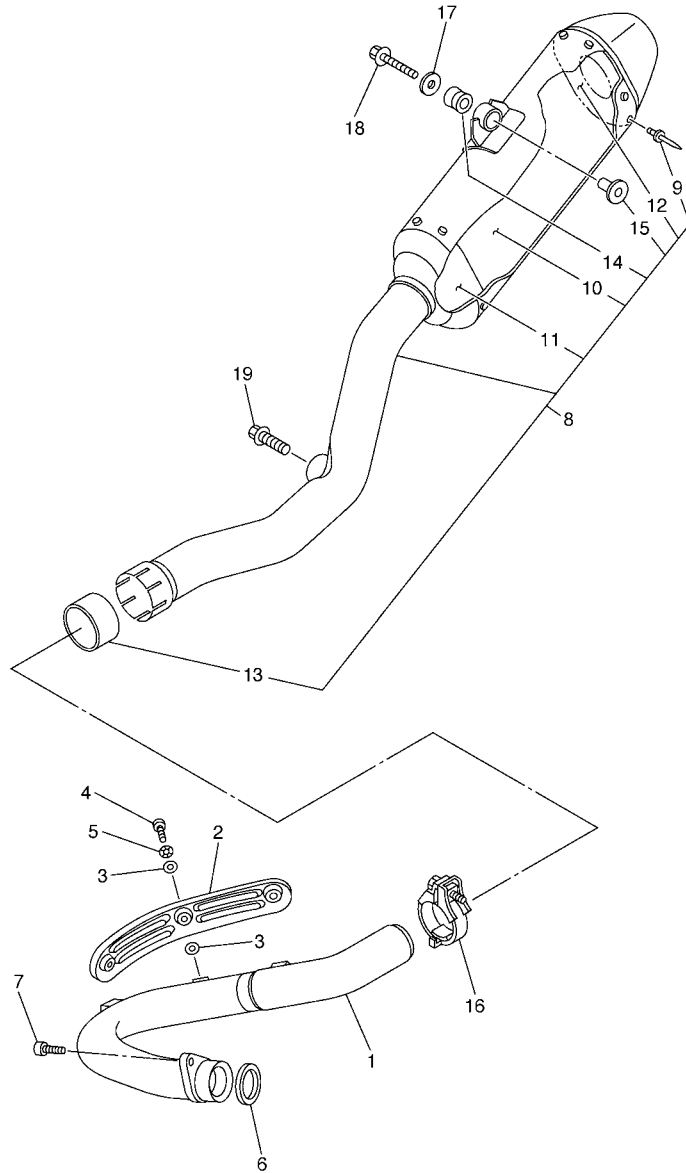

5XC9100-E110

REF. NO.	PART NO.	DESCRIPTION	NOA	EUR	JPN	ANZ	REMARKS
1	5XC-14611-10	PIPE, EXHAUST 1	1	1	1	1	
2	5XC-14628-00	PROTECTOR, EXHAUST PIPE	1	1	1	1	
3	4BD-14766-00	WASHER, PROTECTOR	6	6	6	6	
4	98980-06008	SCREW, BIND	3	3	3	3	
5	90206-06090	WASHER, WAVE	3	3	3	3	
6	5NL-14613-00	GASKET, EXHAUST PIPE	1	1	1	1	
7	91312-08020	BOLT	1	1	1	1	
8	5XC-14750-00	SILENCER ASSY	1				
	5XC-14750-10	SILENCER ASSY		1	1	1	
9	90267-48084	.RIVET, BLIND	16	16	16	16	
10	5XC-1469A-00	.FIBER	1				
	5XC-1469A-10	.FIBER		1	1	1	
11	2S2-1469E-00	.FIBER	1	1	1	1	
12	2S2-1469F-00	.FIBER	1	1	1	1	
13	5XD-14714-00	.GASKET, MUFFLER	1	1	1	1	
14	5BE-14747-00	.DAMPER, MUFFLER	1	1	1	1	
15	90387-0814J	.COLLAR	1	1	1	1	
16	5BE-14788-00	BAND, SILENCER	1	1	1	1	
17	90201-08008	WASHER, PLATE	1	1	1	1	
18	90105-08659	BOLT, FLANGE	1	1	1	1	
19	90105-08085	BOLT, FLANGE	1	1	1	1	

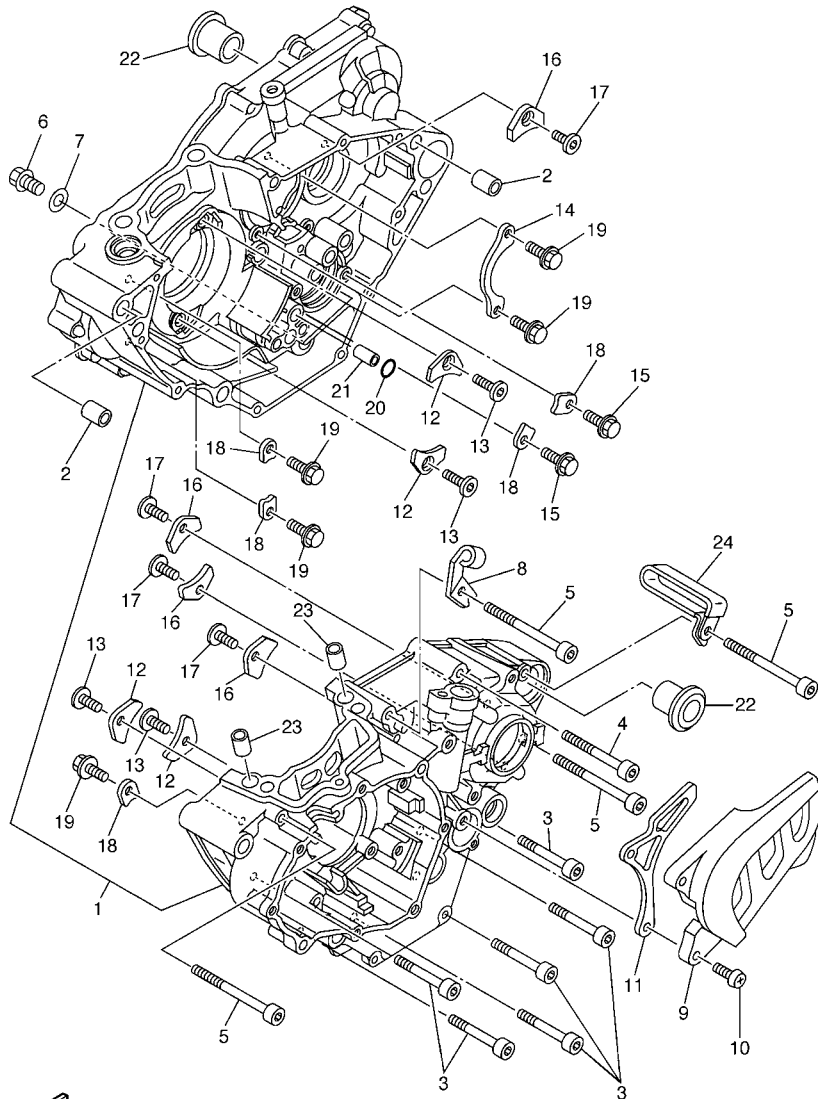

5XC9100-E120

FIG. 12 CRANKCASE

REF. NO.	PART NO.	DESCRIPTION	NOA	EUR	JPN	ANZ	REMARKS
1	5XC-15150-10	CRANKCASE ASSY	1	1	1	1	
2	93612-16254	PIN, DOWEL	2	2	2	2	
3	91312-06045	BOLT	6	6	6	6	
4	91312-06055	BOLT	1	1	1	1	
5	91312-06070	BOLT	4	4	4	4	
6	95022-10016	BOLT, FLANGE	1	1	1	1	
7	90430-10188	GASKET	1	1	1	1	
8	5NL-15441-01	HOLDER, CLUTCH CABLE	1	1	1	1	
9	5BE-15421-10	COVER, CRANKCASE 2	1	1	1	1	
10	98502-06025	SCREW, PAN HEAD	2	2	2	2	
11	5NL-17466-00	GUIDE, CHAIN	1	1	1	1	
12	5BE-15383-01	PLATE, BEARING COVER	4	4	4	4	
13	90149-06126	SCREW	4	4	4	4	
14	5NL-15388-00	PLATE, BEARING COVER	1	1	1	1	
15	90105-06553	BOLT, FLANGE	2	2	2	2	
16	4JT-15381-01	PLATE, BEARING COVER	4	4	4	4	
17	90149-06326	SCREW	4	4	4	4	
18	5DH-18562-00	PLATE, STOPPER 2	5	5	5	5	
19	90105-06553	BOLT, FLANGE	5	5	5	5	
20	93210-10197	O-RING	1	1	1	1	
21	99530-10114	PIN, DOWEL	1	1	1	1	
22	90387-18007	COLLAR	2	2	2	2	
23	99530-10116	PIN, DOWEL	2	2	2	2	
24	90465-10013	CLAMP	1	1	1	1	

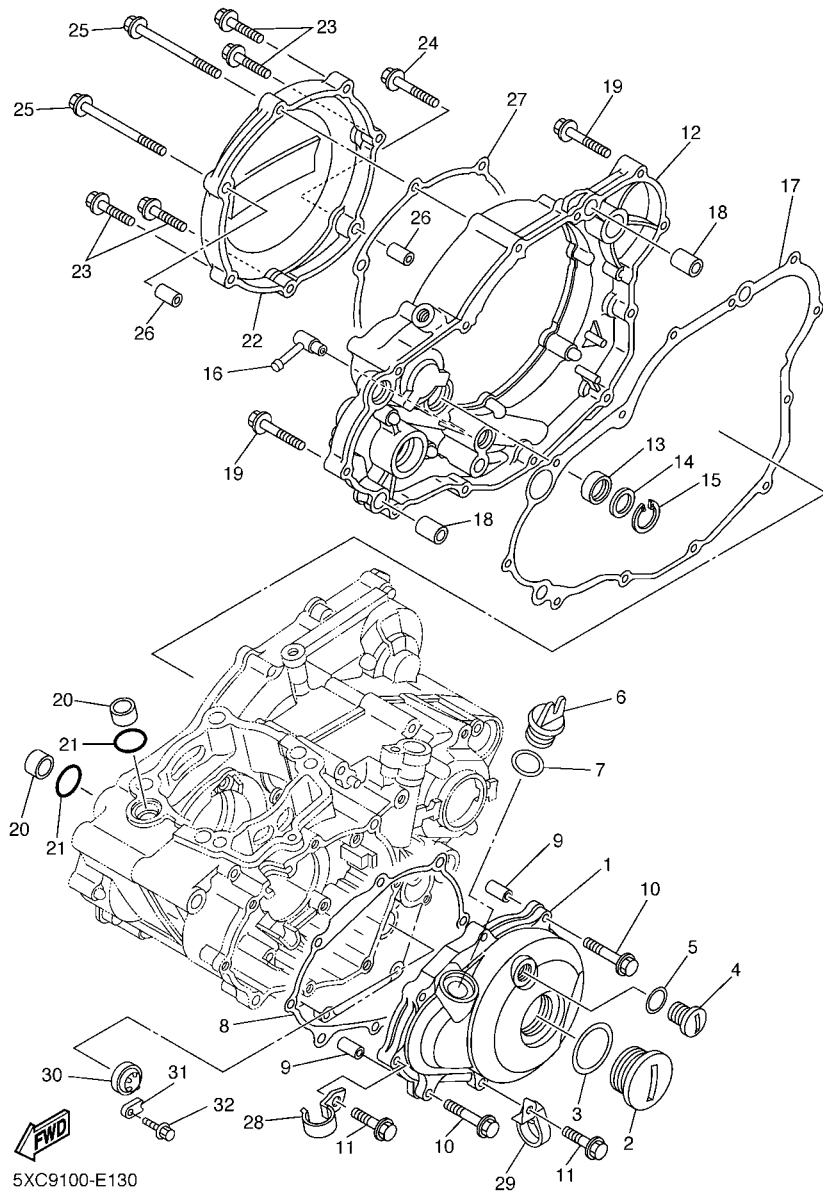

5XC9100-E130

FIG. 13 CRANKCASE COVER 1

REF. NO.	PART NO.	DESCRIPTION	NOA	EUR	JPN	ANZ	REMARKS
1	5NL-15411-10	COVER, CRANKCASE 1	1	1	1	1	
2	90340-32123	PLUG, STRAIGHT SCREW	1	1	1	1	
3	93210-32172	O-RING	1	1	1	1	
4	90340-14128	PLUG, STRAIGHT SCREW	1	1	1	1	
5	93210-14369	O-RING	1	1	1	1	
6	3Y1-15363-00	PLUG, OIL	1	1	1	1	
7	93210-19123	O-RING	1	1	1	1	
8	5NL-15451-00	GASKET, CRANKCASE COVER 1	1	1	1	1	
9	99530-08016	PIN, DOWEL	2	2	2	2	
10	95022-06035	BOLT, FLANGE	2	2	2	2	
11	95022-06025	BOLT, FLANGE	6	6	6	6	
12	5XC-15431-00	COVER, CRANKCASE 3	1	1	1	1	
13	93101-14164	OIL SEAL	1	1	1	1	
14	90201-15701	WASHER, PLATE (T=1.0)	1	1	1	1	
15	99009-22500	CIRCLIP	1	1	1	1	
16	5XC-15373-00	PIPE, BREATHER	1	1	1	1	
17	5NL-15462-00	GASKET, CRANKCASE COVER 3	1	1	1	1	
18	91812-16001	PIN, DOWEL	2	2	2	2	
19	95022-06035	BOLT, FLANGE	8	8	8	8	
20	5NL-12564-00	PIPE, WATER	2	2	2	2	
21	93210-16716	O-RING	2	2	2	2	
22	5NL-15415-00	COVER 1	1	1	1	1	
23	95022-06025	BOLT, FLANGE	4	4	4	4	
24	95022-06035	BOLT, FLANGE	1	1	1	1	
25	90105-06098	BOLT, FLANGE	2	2	2	2	
26	99530-08016	PIN, DOWEL	2	2	2	2	
27	5NL-15453-00	GASKET 1	1	1	1	1	

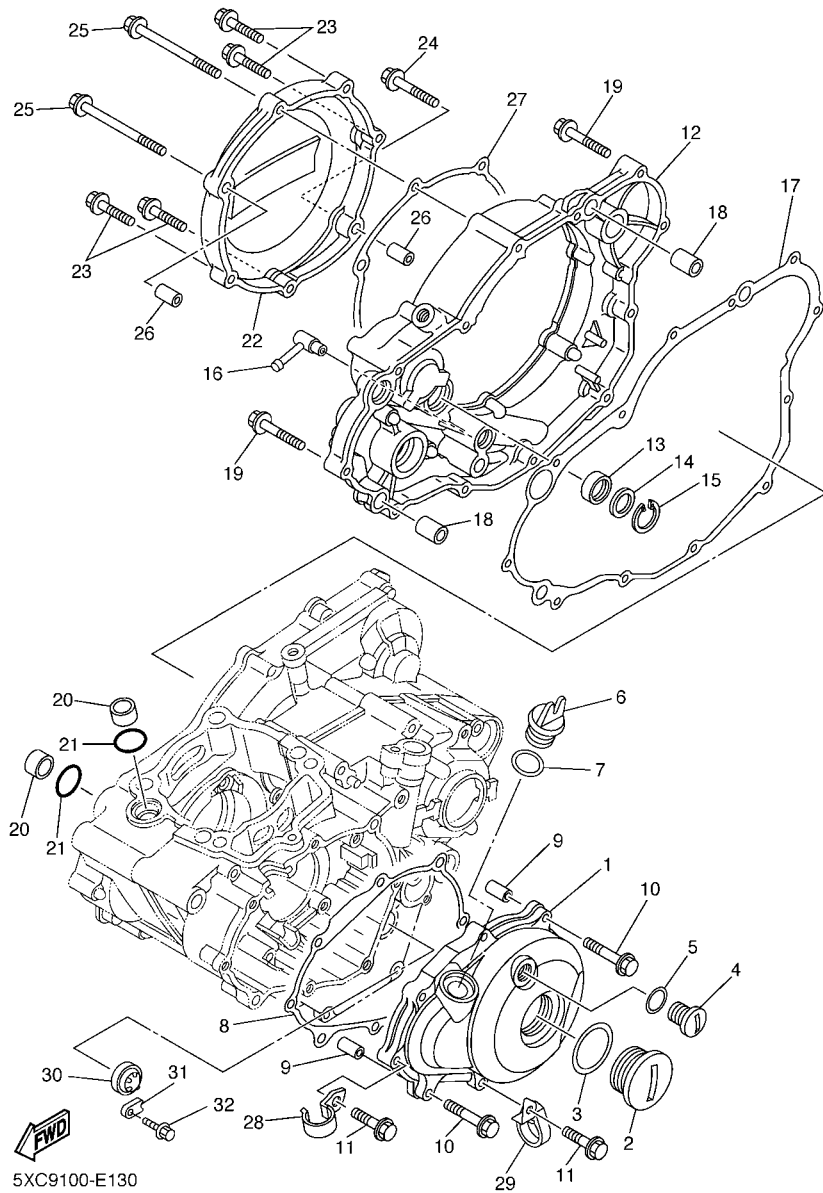

FIG. 13 CRANKCASE COVER 1

REF. NO.	PART NO.	DESCRIPTION	NOA	EUR	JPN	ANZ	REMARKS
28	90465-08029	CLAMP	1	1	1	1	
29	5XD-15378-00	HOLDER	1	1	1	1	
30	3Y1-15361-00	GAUGE, LEVEL	1	1	1	1	
31	5XC-15118-00	HOLDER	1	1	1	1	
32	90105-06094	BOLT, FLANGE	1	1	1	1	

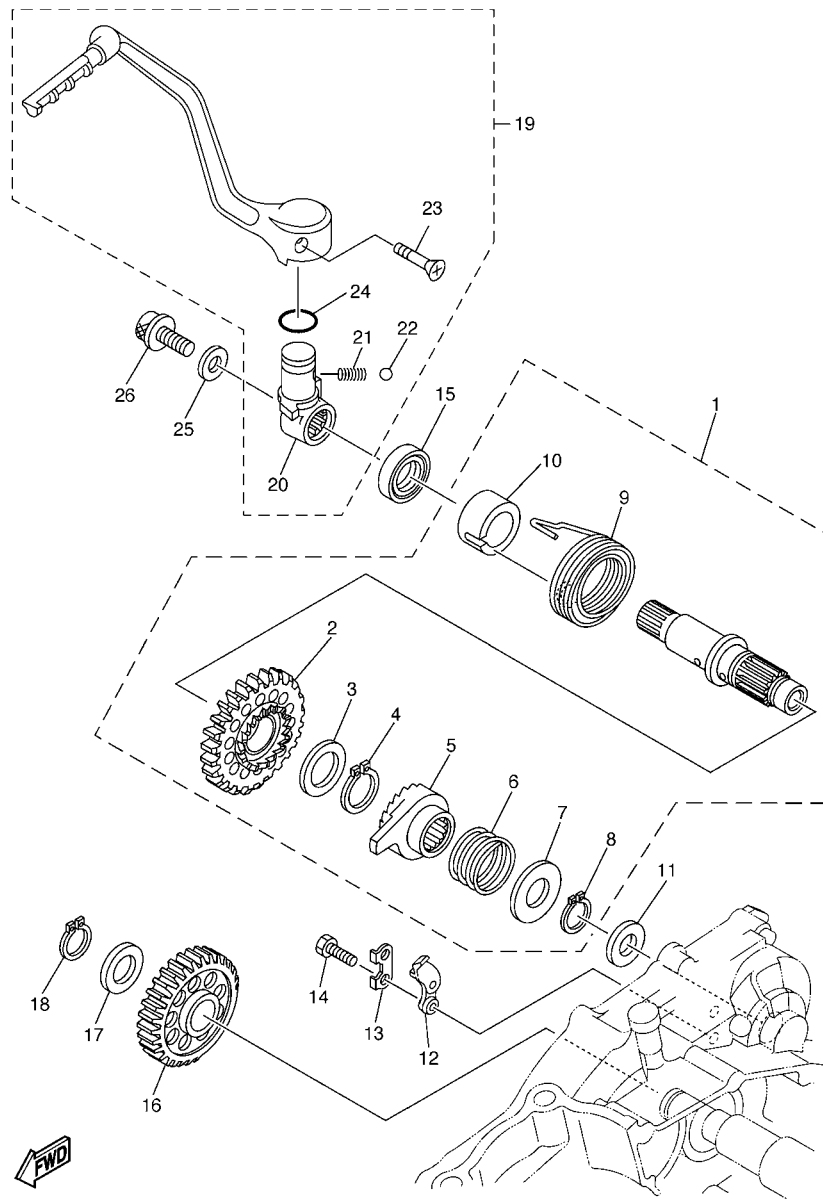
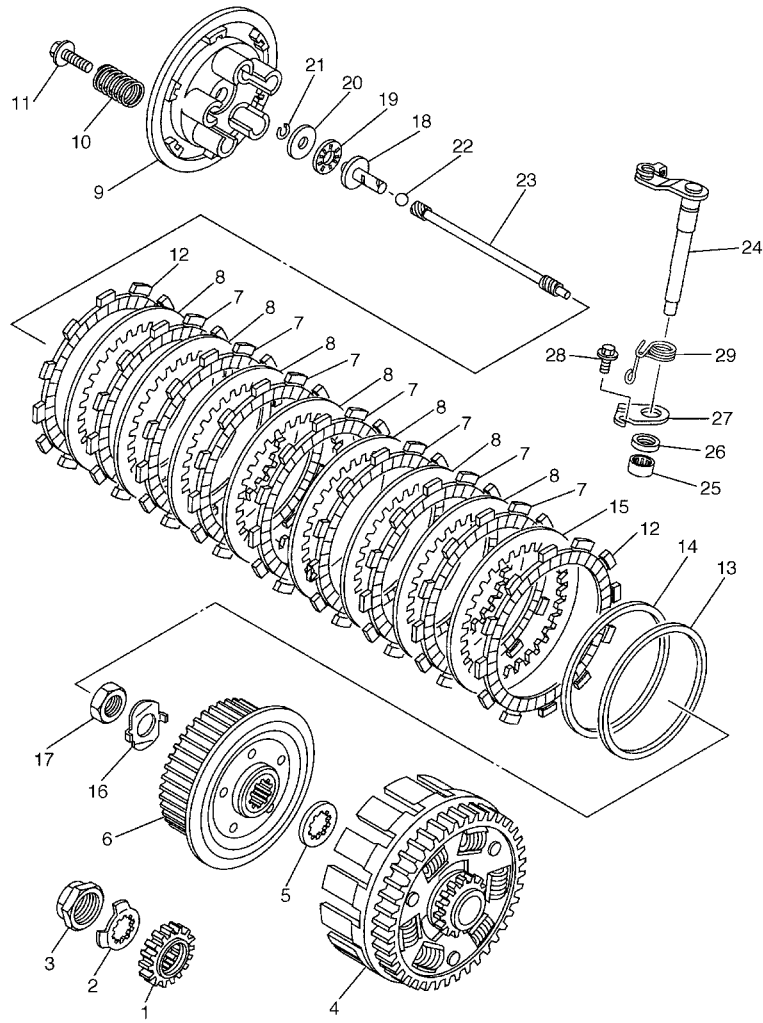

FIG. 14 STARTER

REF. NO.	PART NO.	DESCRIPTION	NOA	EUR	JPN	ANZ	REMARKS
1	5NL-15601-10	KICK SHAFT ASSY	1	1	1	1	
2	5NL-15641-10	.GEAR, KICK	1	1	1	1	
3	90201-20685	.WASHER, PLATE (T=0.5)	1	1	1	1	
4	93410-20038	.CIRCLIP	1	1	1	1	
5	4GY-15671-00	.WHEEL, RATCHET	1	1	1	1	
6	90501-16016	.SPRING, COMPRESSION	1	1	1	1	
7	90201-167P7	.WASHER, PLATE	1	1	1	1	
8	99009-16400	.CIRCLIP	1	1	1	1	
9	90508-30743	.SPRING, TORSION	1	1	1	1	
10	5NL-15664-00	.GUIDE, SPRING	1	1	1	1	
11	90201-162H4	WASHER, PLATE	1	1	1	1	
12	5SG-15668-00	STOPPER	1	1	1	1	
13	214-15686-00	WASHER, LOCK	1	1	1	1	
14	90101-06001	BOLT	2	2	2	2	
15	93102-18278	OIL SEAL	1	1	1	1	
16	5NL-15651-00	GEAR, KICK IDLE	1	1	1	1	
17	90201-177G4	WASHER, PLATE	1	1	1	1	
18	99009-17400	CIRCLIP	1	1	1	1	
19	5XC-15620-00	KICK CRANK ASSY	1	1	1	1	
20	5XC-15621-00	.BOSS, KICK CRANK	1	1	1	1	
21	90501-147A5	.SPRING, COMPRESSION	1	1	1	1	
22	93507-32009	.BALL	1	1	1	1	
23	90152-06010	.SCREW, COUNTERSUNK	1	1	1	1	
24	93210-17570	.O-RING	1	1	1	1	
25	90201-08048	WASHER, PLATE	1	1	1	1	
26	90110-08051	BOLT, HEXAGON SOCKET HEAD	1	1	1	1	



FWD
5XC5100-D150

FIG. 15 CLUTCH

REF. NO.	PART NO.	DESCRIPTION	NOA	EUR	JPN	ANZ	REMARKS
1	5NL-16111-00	GEAR, PRIMARY DRIVE	1	1	1	1	
2	90215-20003	WASHER, LOCK	1	1	1	1	
3	90179-18001	NUT	1	1	1	1	
4	5NL-16150-10	PRIMARY DRIVEN GEAR COMP.	1	1	1	1	
5	5NL-16154-00	PLATE, THRUST 1	1	1	1	1	
6	5NL-16371-00	BOSS, CLUTCH	1	1	1	1	
7	5DH-16321-00	PLATE, FRICTION	7	7	7	7	
8	5NL-16325-00	PLATE, CLUTCH 2	7	7	7	7	
9	5HD-16351-00	PLATE, PRESSURE 1	1	1	1	1	
10	90501-224J9	SPRING, COMPRESSION	5	5	5	5	(PINK)
11	90159-06092	SCREW, WITH WASHER	5	5	5	5	
12	3XJ-16321-00	PLATE, FRICTION	2	2	2	2	
13	5NL-16384-00	PLATE, SEAT	1	1	1	1	
14	5NL-16383-10	SPRING, CLUTCH BOSS	1	1	1	1	
15	5NL-16325-10	PLATE, CLUTCH 2	1	1	1	1	
16	90215-16289	WASHER, LOCK	1	1	1	1	
17	90170-16326	NUT	1	1	1	1	
18	5NL-16356-00	ROD, PUSH 1	1	1	1	1	
19	93340-21008	BEARING	1	1	1	1	
20	90201-080H1	WASHER, PLATE	1	1	1	1	
21	93440-07182	CIRCLIP	1	1	1	1	
22	93511-32027	BALL	1	1	1	1	
23	5NL-16357-10	ROD, PUSH 2	1	1	1	1	
24	5JG-16381-00	PUSH LEVER COMP.	1	1	1	1	
25	93317-11287	BEARING	1	1	1	1	
26	93102-12224	OIL SEAL	1	1	1	1	
27	4JT-16384-00	PLATE, SEAT	1	1	1	1	

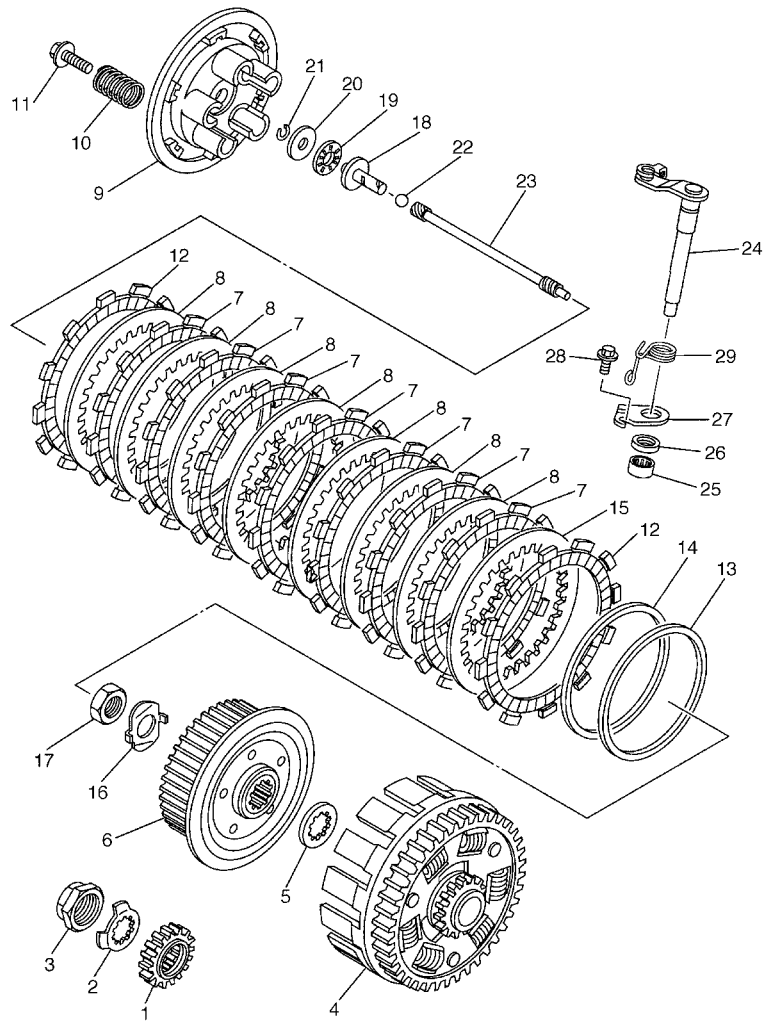

5XC5100-D150

FIG. 15 CLUTCH

REF. NO.	PART NO.	DESCRIPTION	NOA	EUR	JPN	ANZ	REMARKS
28	95022-06010	BOLT, FLANGE	1	1	1	1	
29	90508-12018	SPRING, TORSION	1	1	1	1	

FIG. 16 TRANSMISSION

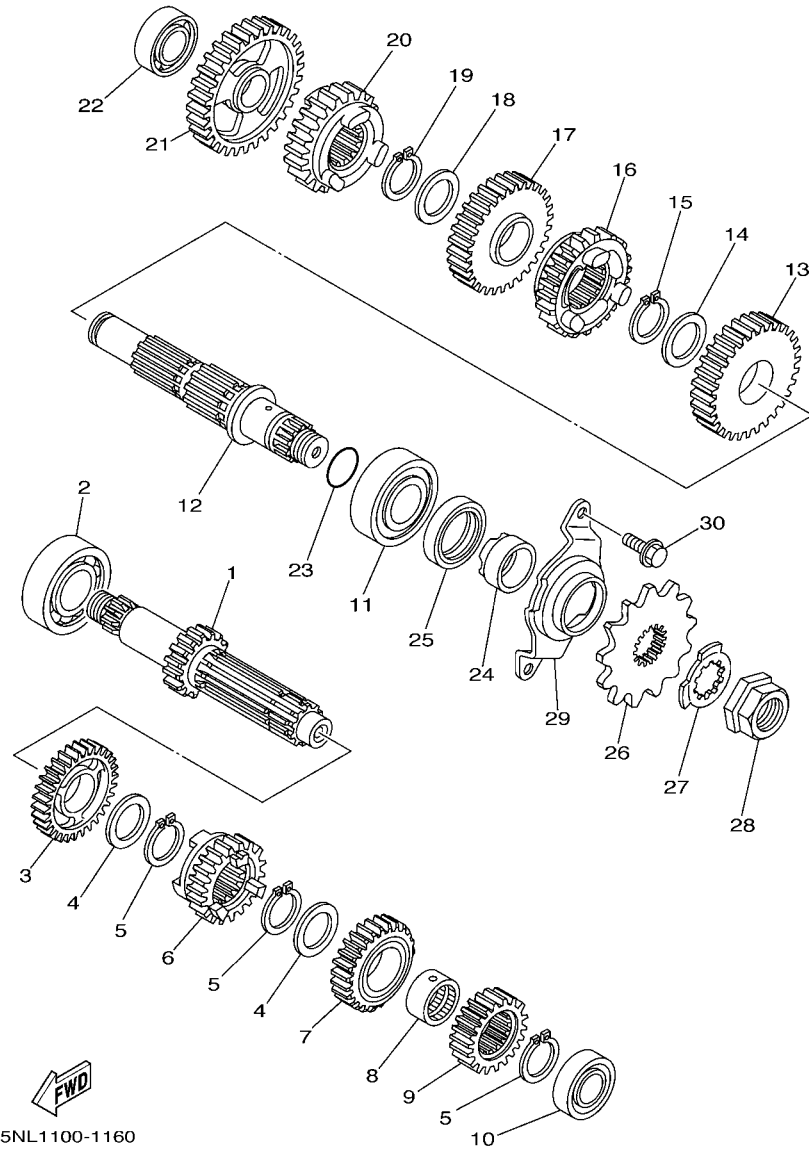

REF. NO.	PART NO.	DESCRIPTION	NOA	EUR	JPN	ANZ	REMARKS
1	5NL-17411-10	AXLE,MAIN (14T)	1	1	1	1	
2	93306-20447	BEARING	1	1	1	1	
3	5NL-17151-00	GEAR, 5TH PINION (24T)	1	1	1	1	
4	90209-20008	WASHER	2	2	2	2	
5	93410-22039	CIRCLIP	3	3	3	3	
6	5NL-17131-10	GEAR, 3RD PINION (20T)	1	1	1	1	
7	5NL-17141-10	GEAR, 4TH PINION (22T)	1	1	1	1	
8	90387-20006	COLLAR	1	1	1	1	
9	5NL-17121-00	GEAR, 2ND PINION (16T)	1	1	1	1	
10	93306-00320	BEARING	1	1	1	1	
11	93306-27208	BEARING	1	1	1	1	
12	5NL-17402-00	DRIVE AXLE ASSY	1	1	1	1	
13	5NL-17221-00	GEAR, 2ND WHEEL (28T)	1	1	1	1	
14	90209-23012	WASHER	1	1	1	1	
15	93410-26067	CIRCLIP	1	1	1	1	
16	5NL-17241-11	GEAR, 4TH WHEEL (27T)	1	1	1	1	
17	5NL-17231-10	GEAR, 3RD WHEEL (29T)	1	1	1	1	
18	90209-20008	WASHER	1	1	1	1	
19	93410-22039	CIRCLIP	1	1	1	1	
20	5NL-17251-10	GEAR, 5TH WHEEL (25T)	1	1	1	1	
21	5NL-17211-10	GEAR, 1ST WHEEL (30T)	1	1	1	1	
22	93306-00317	BEARING	1	1	1	1	
23	93210-196A4	O-RING	1	1	1	1	
24	90387-22001	COLLAR	1	1	1	1	
25	93102-28010	OIL SEAL	1	1	1	1	
26	9383B-13218	SPROCKET, DRIVE (13T)	1	1	1	1	
27	90215-20003	WASHER, LOCK	1	1	1	1	

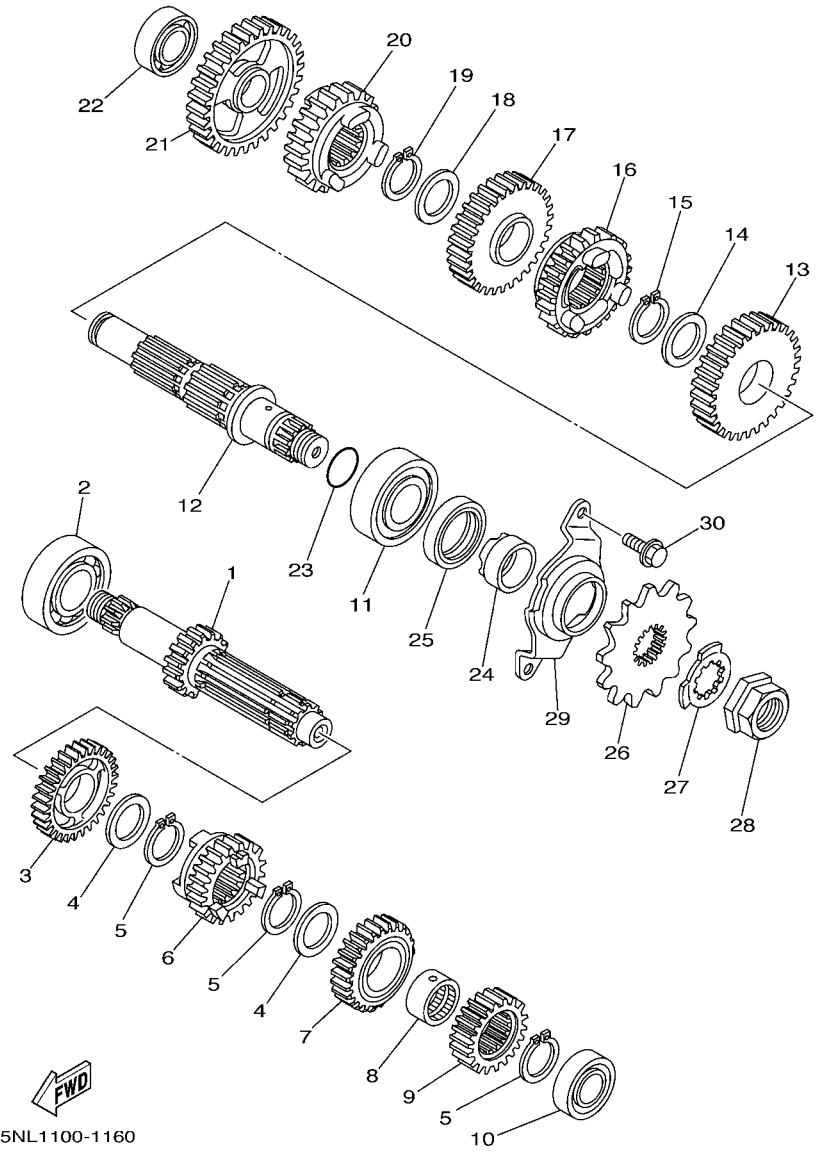
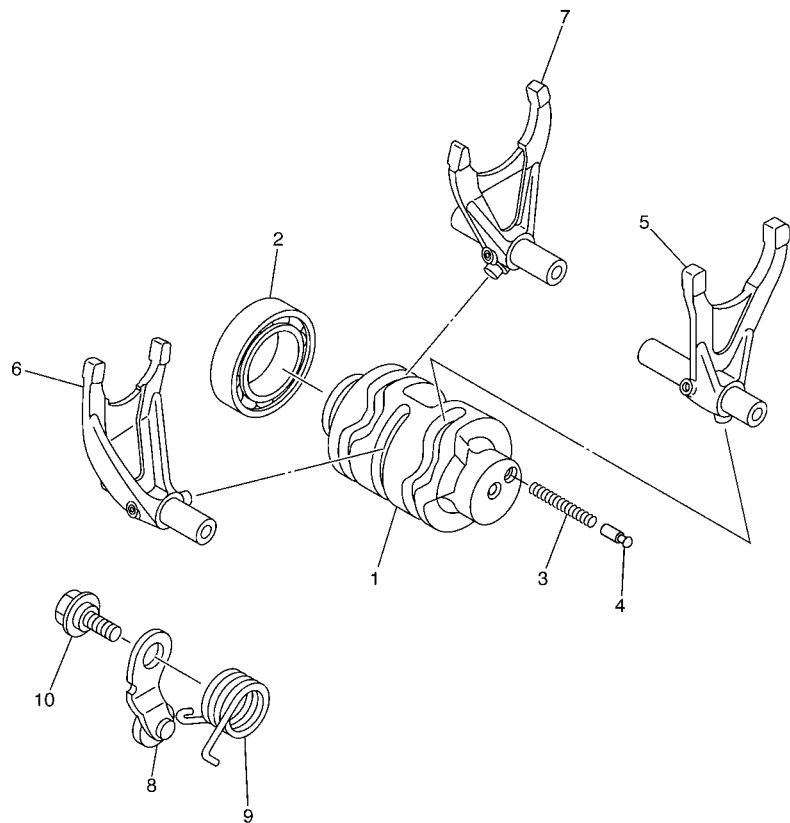

FIG. 16 TRANSMISSION

REF. NO.	PART NO.	DESCRIPTION	NOA	EUR	JPN	ANZ	REMARKS
28	90179-18001	NUT	1	1	1	1	
29	5NL-17471-10	PLATE, COVER	1	1	1	1	
30	90105-06553	BOLT, FLANGE	2	2	2	2	

FIG. 17 SHIFT CAM & FORK



5XC9100-E170

REF. NO.	PART NO.	DESCRIPTION	NOA	EUR	JPN	ANZ	REMARKS
1	5NL-18541-00	CAM, SHIFT	1	1	1	1	
2	93306-90501	BEARING	1	1	1	1	
3	90501-06022	SPRING, COMPRESSION	1	1	1	1	
4	4UN-18542-00	POINT, NEUTRAL	1	1	1	1	
5	5NL-18501-00	FORK, SHIFT 1	1	1	1	1	
6	5NL-18502-00	FORK, SHIFT 2	1	1	1	1	
7	5NL-18503-00	FORK, SHIFT 3	1	1	1	1	
8	3XK-18140-00	STOPPER LEVER ASSY	1	1	1	1	
9	90508-26561	SPRING, TORSION	1	1	1	1	
10	90109-063F8	BOLT	1	1	1	1	

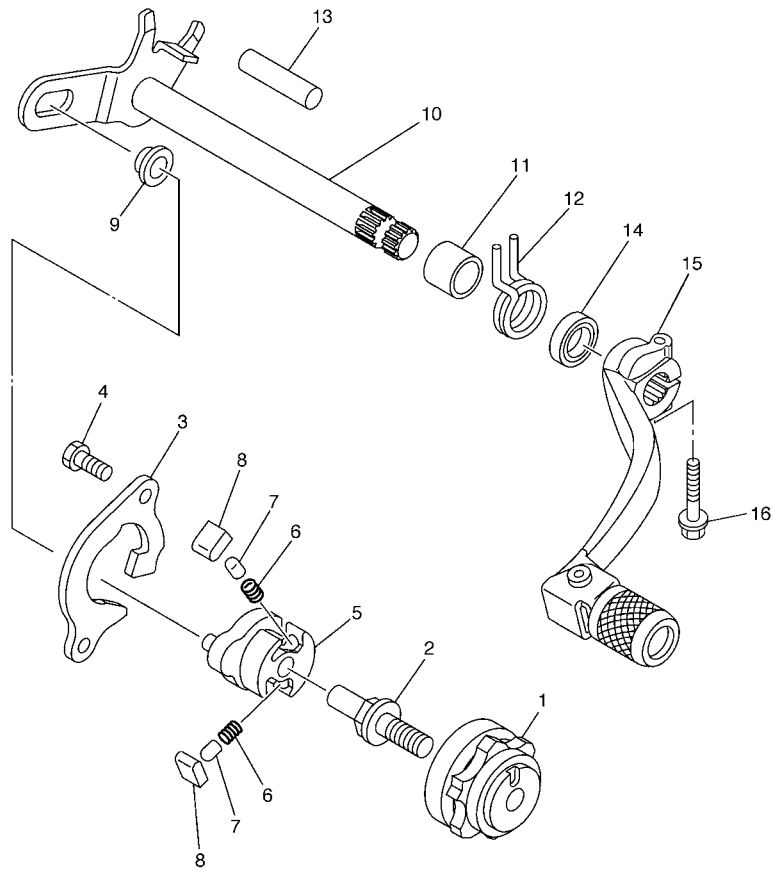

5XC9100-E180

FIG. 18 SHIFT SHAFT

REF. NO.	PART NO.	DESCRIPTION	NOA	EUR	JPN	ANZ	REMARKS
1	4EW-18185-00	SEGMENT	1	1	1	1	
2	3XJ-18173-10	PIN, SHIFT	1	1	1	1	
3	5BE-18172-00	GUIDE, SHIFT	1	1	1	1	
4	90101-06041	BOLT	2	2	2	2	
5	5LP-18122-01	LEVER, SHIFT 2	1	1	1	1	
6	90501-052G5	SPRING, COMPRESSION	2	2	2	2	
7	3XJ-18184-00	PIN, PAWL	2	2	2	2	
8	3XJ-18182-00	PAWL, SHIFTER	2	2	2	2	
9	3XJ-18178-00	ROLLER, SHIFT LEVER	1	1	1	1	
10	5UL-18101-00	SHIFT SHAFT ASSY	1	1	1	1	
11	90387-124F4	COLLAR	1	1	1	1	
12	90508-291A8	SPRING, TORSION	1	1	1	1	
13	93608-33002	PIN, DOWEL	1	1	1	1	
14	93102-12224	OIL SEAL	1	1	1	1	
15	5XC-18110-00	SHIFT PEDAL ASSY	1	1	1	1	
16	95022-06020	BOLT, FLANGE	1	1	1	1	

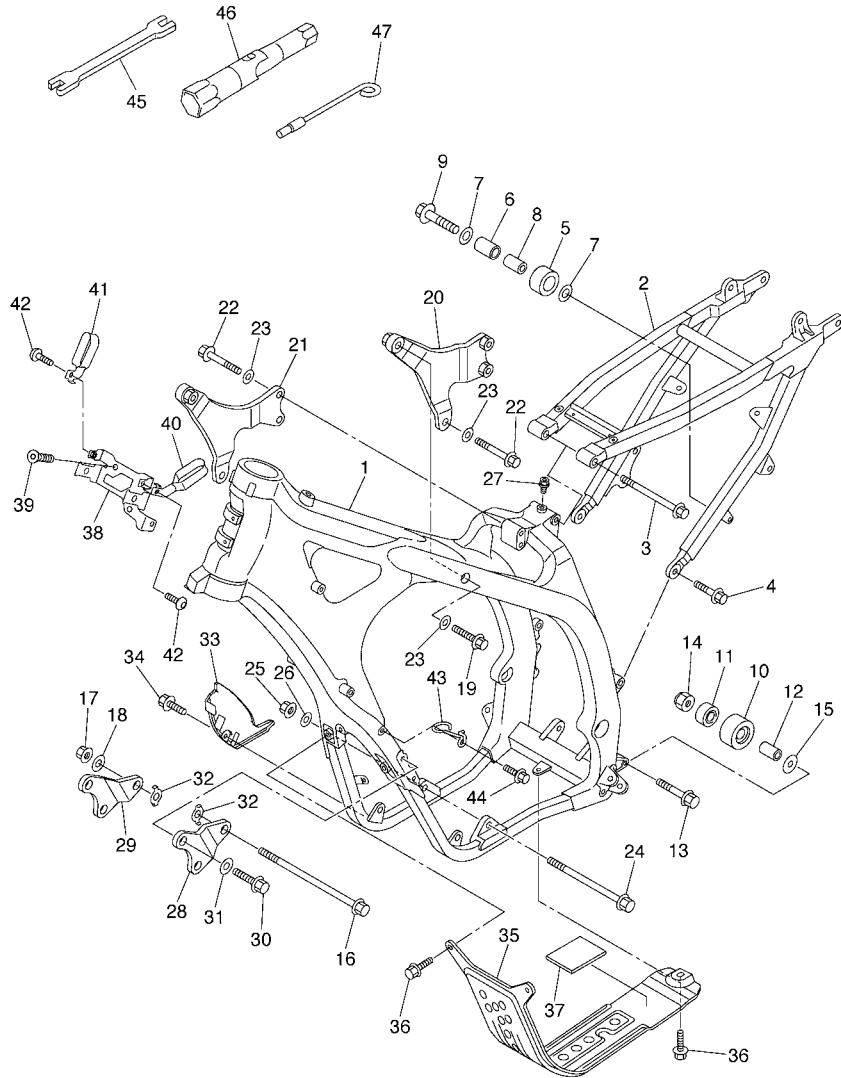

5XC9100-E190

FIG. 19 FRAME

REF. NO.	PART NO.	DESCRIPTION	NOA	EUR	JPN	ANZ	REMARKS
1	5XC-21101-90	FRONT FRAME COMP.	1	1	1	1	
2	5XC-21190-90	REAR FRAME COMP.	1	1	1	1	
3	90105-08115	BOLT, FLANGE	1	1	1	1	
4	90105-08085	BOLT, FLANGE	2	2	2	2	
5	30X-22178-00	TENSIONER	1	1	1	1	
6	4V4-22184-00	BUSH	1	1	1	1	
7	90201-08045	WASHER, PLATE	2	2	2	2	
8	90387-08041	COLLAR	1	1	1	1	
9	95022-08040	BOLT, FLANGE	1	1	1	1	
10	3JD-22178-20	TENSIONER	1	1	1	1	
11	93300-60839	BEARING	1	1	1	1	
12	90387-086N4	COLLAR	1	1	1	1	
13	95024-08045	BOLT, FLANGE	1	1	1	1	
14	90185-08009	NUT, SELF-LOCKING	1	1	1	1	
15	90201-08043	WASHER, PLATE	1	1	1	1	
16	90105-10079	BOLT, FLANGE	1	1	1	1	
17	90179-10658	NUT	1	1	1	1	
18	90201-104R2	WASHER, PLATE	1	1	1	1	
19	95817-10030	BOLT, FLANGE	2	2	2	2	
20	5XC-21425-90	BRACKET, REAR UPPER 1	1	1	1	1	
21	5XC-21426-90	BRACKET, REAR UPPER 2	1	1	1	1	
22	95817-10060	BOLT, FLANGE	3	3	3	3	
23	90201-104R2	WASHER, PLATE	5	5	5	5	
24	90105-10072	BOLT, FLANGE	1	1	1	1	
25	90179-10658	NUT	1	1	1	1	
26	90201-104R2	WASHER, PLATE	1	1	1	1	
27	1C3-21244-10	NUT	1	1	1	1	

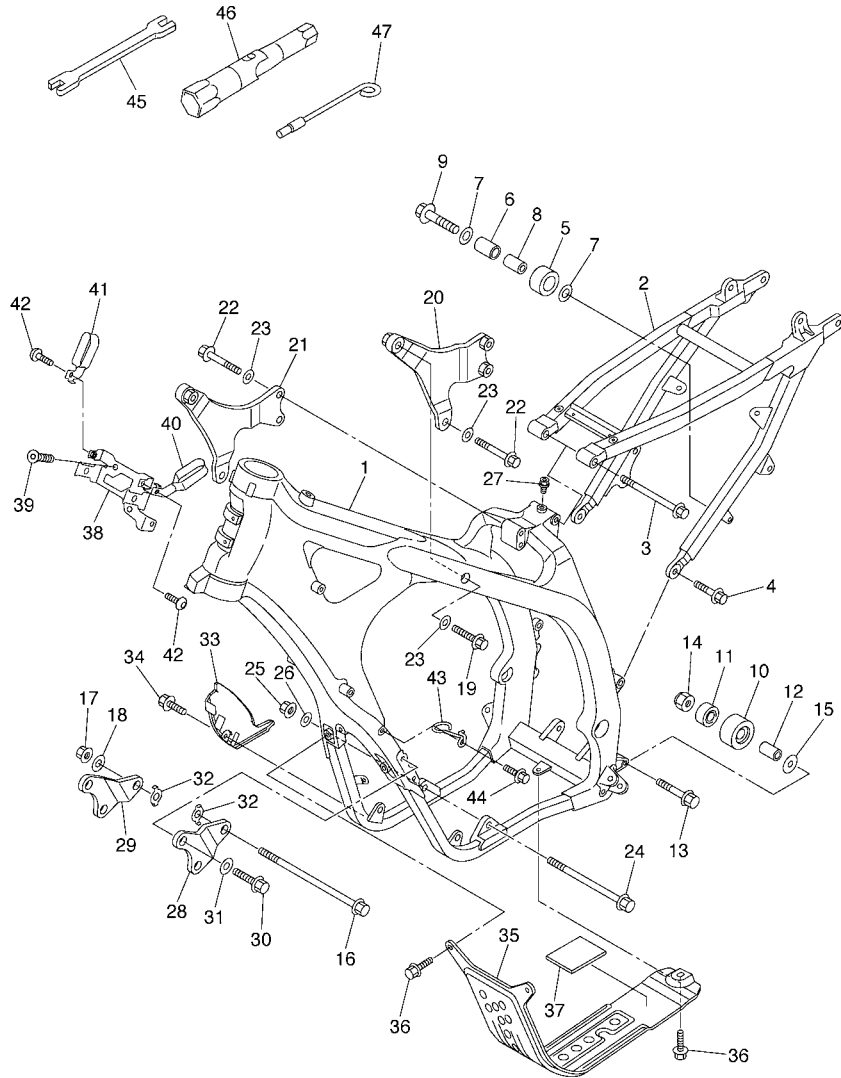

FIG. 19 FRAME

REF. NO.	PART NO.	DESCRIPTION	NOA	EUR	JPN	ANZ	REMARKS
28	5XC-21417-90	BRACKET, FRONT LOWER 1	1	1	1	1	
29	5XC-21418-90	BRACKET, FRONT LOWER 2	1	1	1	1	
30	90105-08129	BOLT, FLANGE	4	4	4	4	
31	92903-08200	WASHER, PLAIN	4	4	4	4	
32	5XC-21456-90	PLATE, PATCH	2	2	2	2	
33	5XC-21471-90	PROTECTOR, ENGINE	1	1	1	1	
34	90119-06217	BOLT, WITH WASHER	1	1	1	1	
35	5XC-2147E-91	GUARD, ENGINE 2	1	1	1	1	
36	90119-06217	BOLT, WITH WASHER	3	3	3	3	
37	5XC-21486-90	DAMPER 2	1	1	1	1	
38	5XC-21274-90	BRACKET, C.D.I. UNIT	1	1	1	1	
39	90151-06032	SCREW, COUNTERSUNK	2	2	2	2	
40	5XC-21163-90	HOLDER, CLUTCH CABLE	1	1	1	1	
41	5XC-21164-90	HOLDER, CABLE	1	1	1	1	
42	92012-05008	BOLT, BUTTON HEAD	2	2	2	2	
43	5XC-21288-90	GUIDE, CABLE	1	1	1	1	
44	90105-05014	BOLT, FLANGE	1	1	1	1	
45	5ET-28166-10	WRENCH, HEXAGON	1	1	1	1	
46	5TA-2814F-00	BOX, SPARK PLUG	1	1	1	1	
47	5XC-28116-00	TOOL, SPECIAL	1	1	1	1	



5XC9100-E190

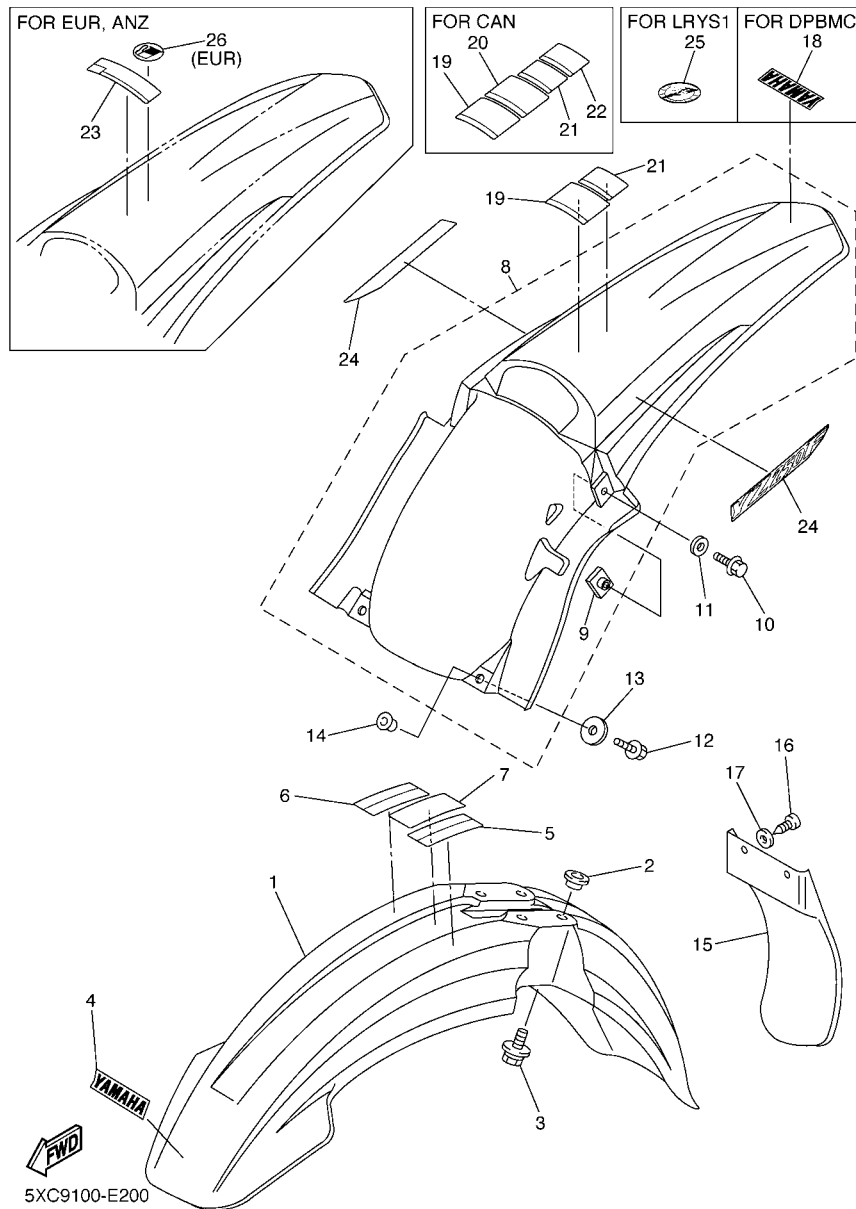

FIG. 20 FENDER

REF. NO.	PART NO.	DESCRIPTION	NOA	EUR	JPN	ANZ	REMARKS
1	1C3-21511-50	FENDER, FRONT	1	1	1	1	UR FOR DPBSE
	5XC-21511-D0	FENDER, FRONT	1		1	1	UR FOR LRY1
2	90387-06090	COLLAR	4	4	4	4	
3	90119-06096	BOLT, WITH WASHER	4	4	4	4	
4	4ES-2153E-01	EMBLEM, YAMAHA	1	1	1	1	UR FOR DPBSE
	4ES-2153E-20	EMBLEM, YAMAHA	1		1	1	UR FOR LRY1
5	3FB-2415E-01	LABEL, CAUTION	1				
	3FB-2415E-C0	LABEL, CAUTION			1		JAPANESE
6	3FB-2415E-11	LABEL, CAUTION	1				FOR CAN
7	4SR-2416E-00	LABEL, CAUTION CANADA	1				FOR CAN
8	5XC-21610-90	REAR FENDER COMP.	1	1	1	1	UR FOR DPBSE
	5XC-21610-D0	REAR FENDER COMP.	1		1	1	UR FOR LRY1
9	5XE-21635-10	.NUT, REAR FENDER	2	2	2	2	
10	90105-06090	BOLT, FLANGE	2	2	2	2	
11	90201-06032	WASHER, PLATE	2	2	2	2	
12	95027-06020	BOLT, FLANGE	2	2	2	2	
13	90201-06571	WASHER, PLATE	2	2	2	2	
14	90387-06009	COLLAR	2	2	2	2	
15	5TA-21642-00	GUARD, FLAP	1	1	1	1	
16	97707-60016	SCREW, TAPPING	2	2	2	2	
17	90201-06084	WASHER, PLATE	2	2	2	2	
18	5XC-2153E-00	EMBLEM, YAMAHA	1	1	1	1	FOR DPBSE
19	5PA-2118K-00	LABEL, CAUTION	1				
	5PA-2118K-20	LABEL, CAUTION			1		JAPANESE
20	5PA-2118K-10	LABEL, CAUTION	1				FOR CAN
21	3XJ-2151H-A1	LABEL 5	1				
	4LB-2151H-02	LABEL 5			1		JAPANESE

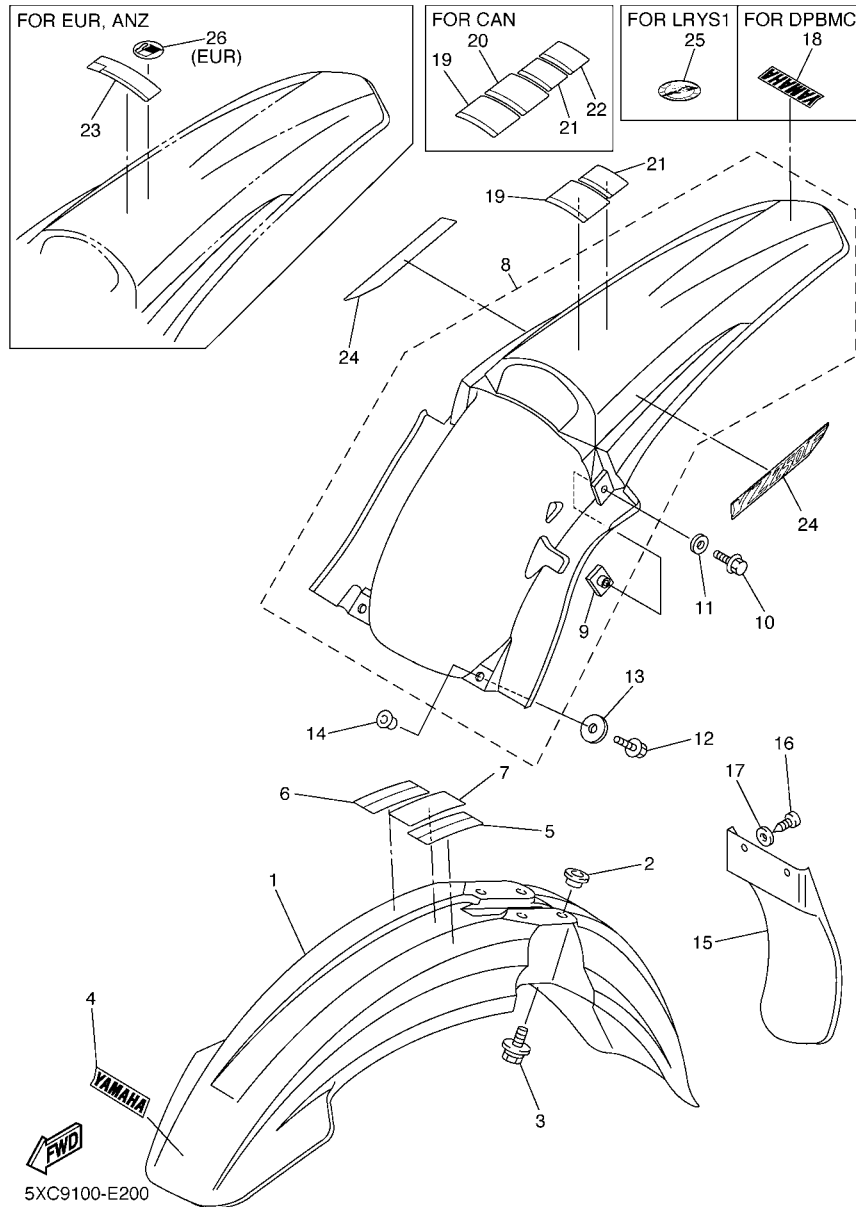

FIG. 20 FENDER

REF. NO.	PART NO.	DESCRIPTION	NOA	EUR	JPN	ANZ	REMARKS
22	3XJ-2151H-B1	LABEL 5	1				FOR CAN
23	5PA-21568-00	LABEL, WARNING		1		1	
24	5XC-2163G-10	EMBLEM 1	2	2	2	2	UR FOR DPBSE
	5XC-2163G-20	EMBLEM 1	2		2	2	UR FOR LRY1
25	5XC-2164B-00	EMBLEM,3D	1		1	1	FOR LRY1
26	3ME-2415E-01	LABEL, CAUTION		1			

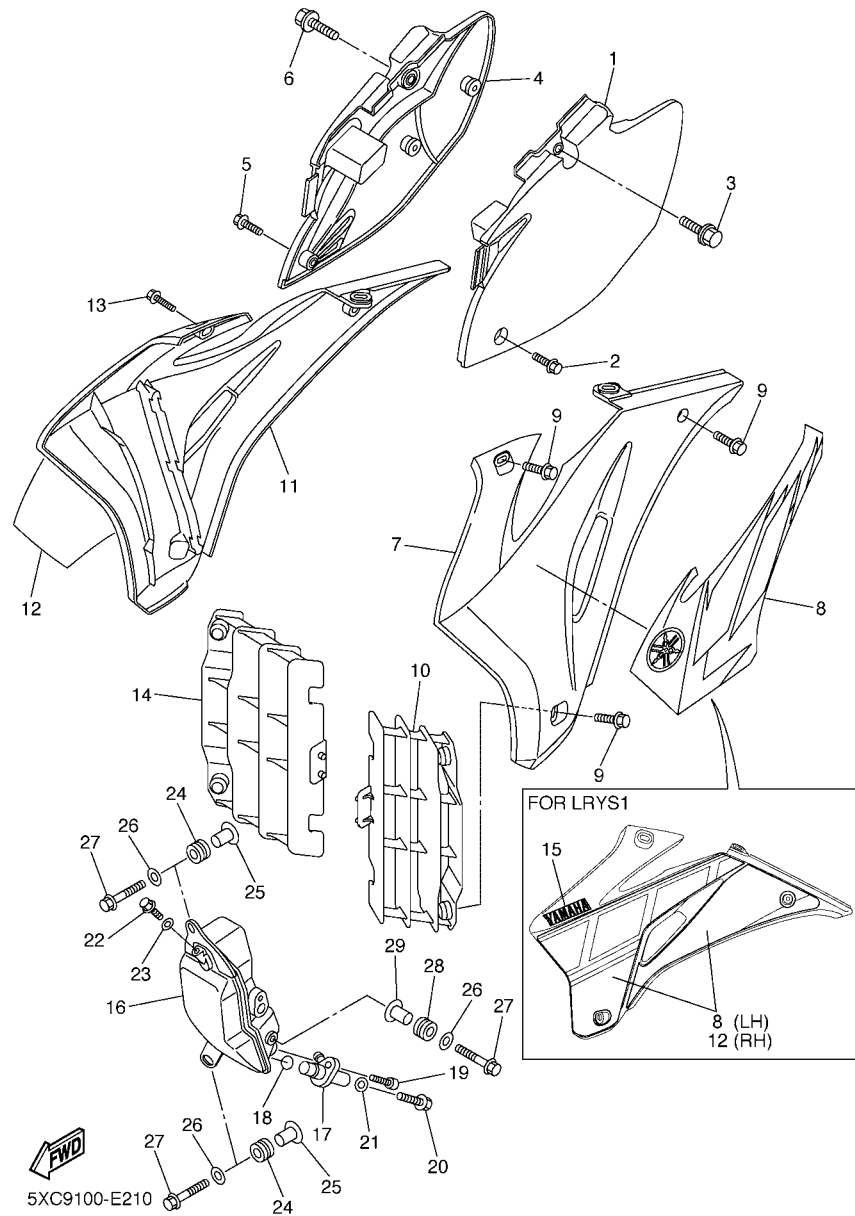
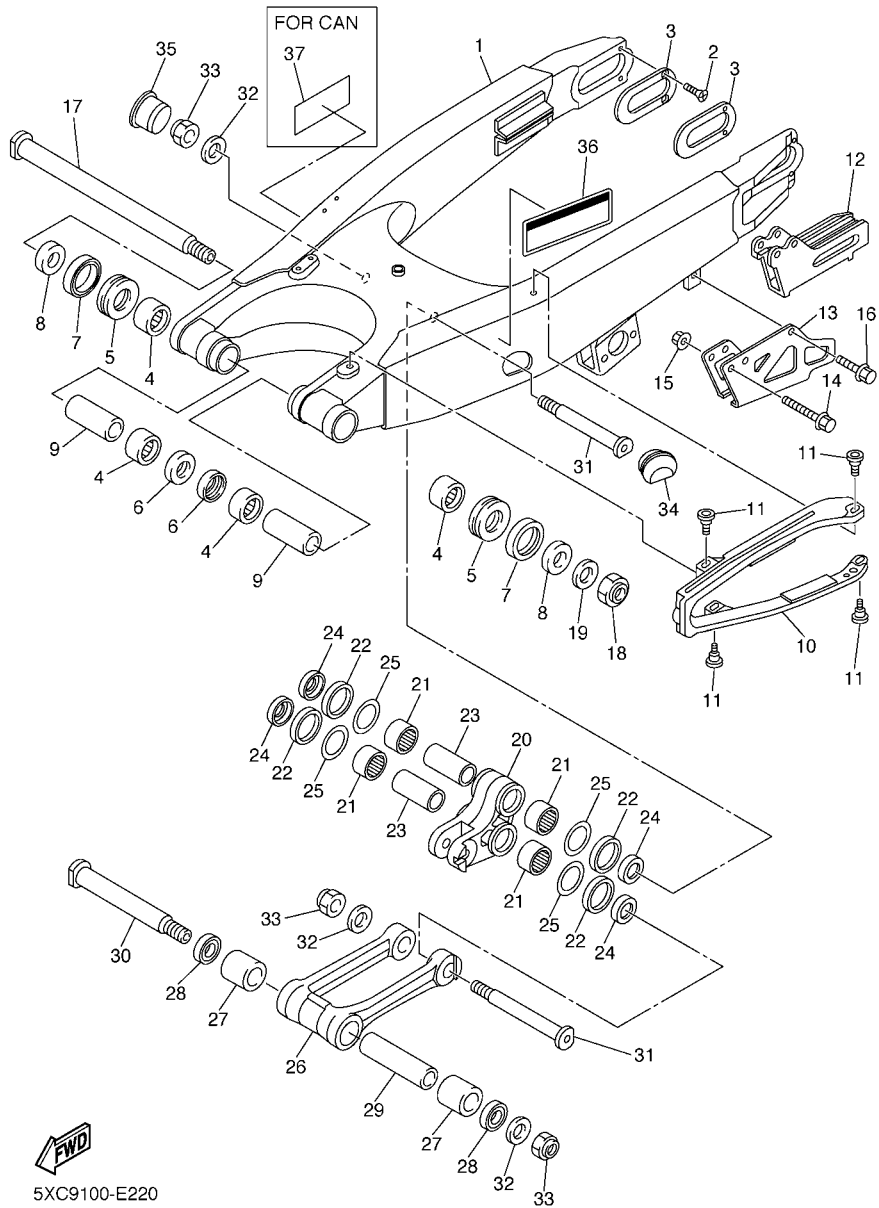

FIG. 21 SIDE COVER & OIL TANK

REF. NO.	PART NO.	DESCRIPTION	NOA	EUR	JPN	ANZ	REMARKS
1	5XC-21710-90	SIDE COVER ASSY 1	1	1	1	1	
2	95824-06016	BOLT, FLANGE	1	1	1	1	
3	90119-08086	BOLT, WITH WASHER	1	1	1	1	
4	5XC-21720-90	SIDE COVER ASSY 2	1	1	1	1	
5	95824-06016	BOLT, FLANGE	1	1	1	1	
6	90119-08086	BOLT, WITH WASHER	1	1	1	1	
7	5XC-21730-90	SIDE COVER ASSY 3	1	1	1	1	UR FOR DPBSE
	5XC-21730-D0	SIDE COVER ASSY 3	1		1	1	UR FOR LRYs1
8	5XC-2173E-01	GRAPHIC 1	1	1	1	1	UR FOR DPBSE
	5XC-2173L-01	GRAPHIC SET 1	1		1	1	UR FOR LRYs1
9	90105-06064	BOLT, FLANGE	4	4	4	4	
10	5XC-2172A-90	PANEL 1	1	1	1	1	
11	5XC-21740-90	SIDE COVER ASSY 4	1	1	1	1	UR FOR DPBSE
	5XC-21740-D0	SIDE COVER ASSY 4	1		1	1	UR FOR LRYs1
12	5XC-2173F-01	GRAPHIC 2	1	1	1	1	UR FOR DPBSE
	5XC-2174L-01	GRAPHIC SET 2	1		1	1	UR FOR LRYs1
13	90105-06064	BOLT, FLANGE	4	4	4	4	
14	5XC-2172A-90	PANEL 1	1	1	1	1	
15	4ES-2153E-20	EMBLEM, YAMAHA	2	2	2	2	FOR LRYs1
16	5XC-21751-90	TANK, OIL	1	1	1	1	
17	5XC-13416-90	PIPE, OIL 1	1	1	1	1	
18	93210-14369	O-RING	1	1	1	1	
19	91312-06016	BOLT	1	1	1	1	
20	95022-08012	BOLT, FLANGE	1	1	1	1	
21	90201-082A6	WASHER, PLATE	1	1	1	1	
22	95802-06012	BOLT, FLANGE	1	1	1	1	
23	90201-06630	WASHER, PLATE	1	1	1	1	

FIG. 22 REAR ARM

REF. NO.	PART NO.	DESCRIPTION	NOA	EUR	JPN	ANZ	REMARKS
1	1C3-22110-50	REAR ARM COMP.	1	1	1	1	
2	90151-04001	SCREW, COUNTERSUNK	4	4	4	4	
3	1C3-22355-00	PATCH	2	2	2	2	
4	93317-22262	BEARING	4	4	4	4	
5	93342-22217	BEARING	2	2	2	2	
6	93106-22002	OIL SEAL	2	2	2	2	
7	93109-28043	OIL SEAL	2	2	2	2	
8	90387-18012	COLLAR	2	2	2	2	
9	90387-18004	COLLAR	2	2	2	2	
10	1C3-22151-00	SEAL, GUARD	1	1	1	1	
11	1C3-22969-50	SCREW, 1	4	4	4	4	
12	1C3-22199-10	SUPPORT, CHAIN	1	1	1	1	
13	1C3-22128-00	COVER, THRUST 1	1	1	1	1	
14	95024-06050	BOLT, FLANGE	2	2	2	2	
15	90179-06028	NUT	2	2	2	2	
16	95024-06010	BOLT, FLANGE	1	1	1	1	
17	1C3-22141-10	SHAFT, PIVOT	1	1	1	1	
18	90185-16002	NUT, SELF-LOCKING	1	1	1	1	
19	90201-16018	WASHER, PLATE	1	1	1	1	
20	5XC-2217A-90	ARM, RELAY	1	1	1	1	
21	93315-32166	BEARING	4	4	4	4	
22	93109-25001	OIL SEAL	4	4	4	4	
23	90387-16010	COLLAR	2	2	2	2	
24	90209-16011	WASHER	4	4	4	4	
25	90201-21014	WASHER, PLATE	4	4	4	4	
26	5XC-2217F-90	ROD, CONNECTING 1	1	1	1	1	
27	93315-32269	BEARING	2	2	2	2	



5XC9100-E220

FIG. 22 REAR ARM

REF. NO.	PART NO.	DESCRIPTION	NOA	EUR	JPN	ANZ	REMARKS
28	93109-22019	OIL SEAL	2	2	2	2	
29	90387-14009	COLLAR	1	1	1	1	
30	5XC-22121-90	SHAFT 1	1	1	1	1	
31	1C3-22122-00	SHAFT 2	2	2	2	2	
32	90201-14740	WASHER, PLATE	3	3	3	3	
33	90185-14007	NUT, SELF-LOCKING	3	3	3	3	
34	1C3-2135F-00	COVER	1	1	1	1	
35	1C3-2139R-00	COVER 2	1	1	1	1	
36	3RV-21668-A0	LABEL, TIRE	1	1		1	
37	3RV-21668-B0	LABEL, TIRE	1				FOR CAN

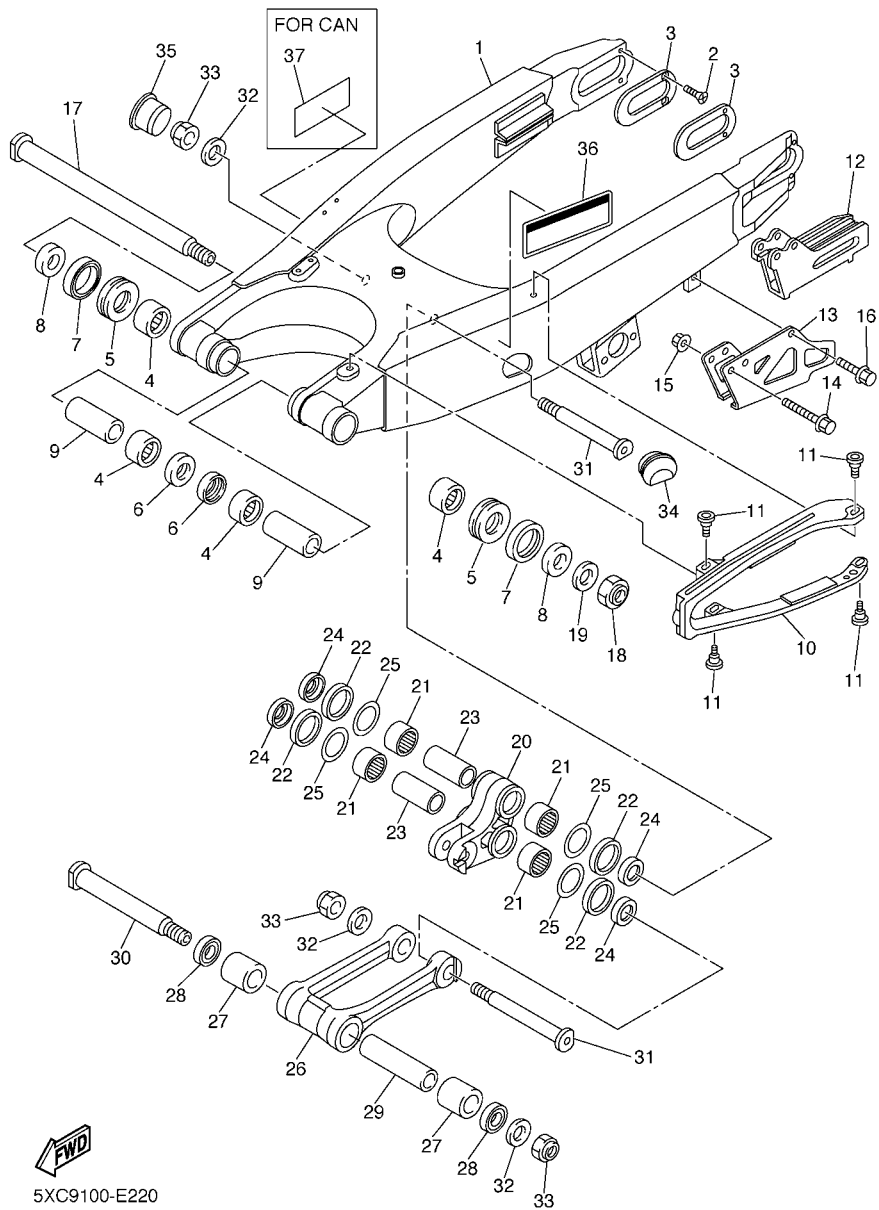

5XC9100-E220

FIG. 23 REAR SUSPENSION

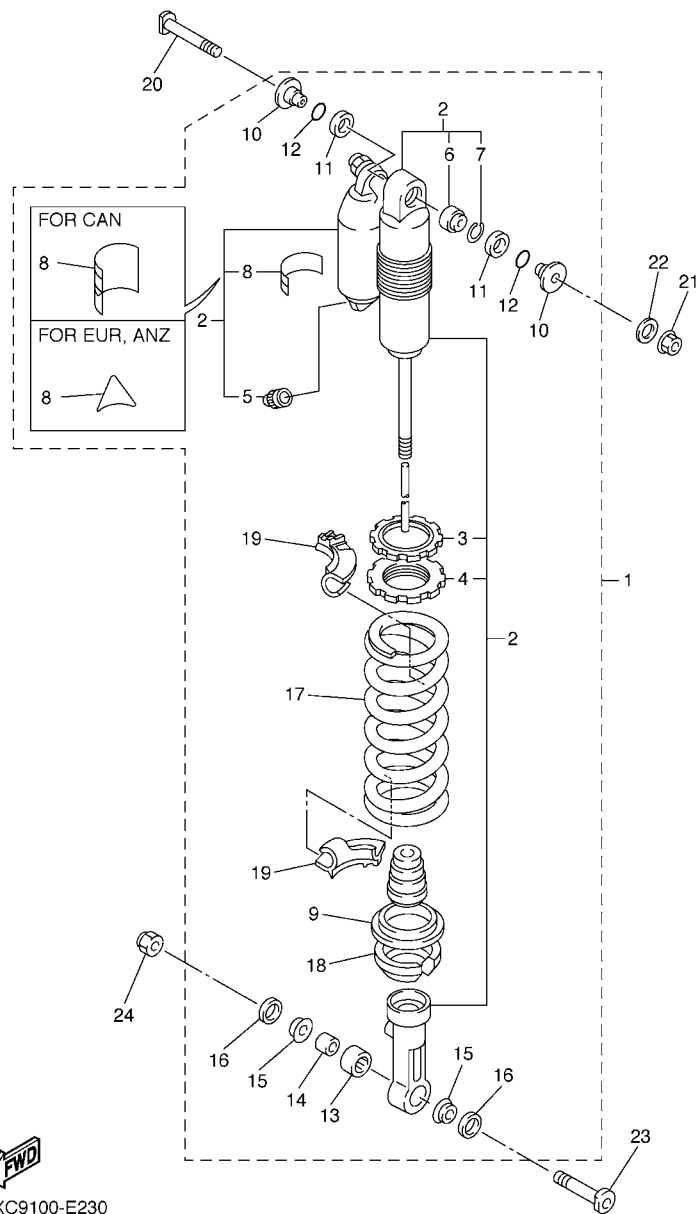

FWD
5XC9100-E230

REF. NO.	PART NO.	DESCRIPTION	NOA	EUR	JPN	ANZ	REMARKS
1	5XC-22200-A0	SHOCK ABSORBER ASSY, REAR	1				UR FOR USA
	5XC-22200-E0	SHOCK ABSORBER ASSY, REAR	1				UR FOR CAN
	5XC-22200-B0	SHOCK ABSORBER ASSY, REAR		1			
	5XC-22200-C0	SHOCK ABSORBER ASSY, REAR			1		
	5XC-22200-D0	SHOCK ABSORBER ASSY, REAR				1	
2	5XC-22201-A0	.DAMPER SUB ASSY	1		1	1	
	5XC-22201-B0	.DAMPER SUB ASSY		1			
3	3SP-22234-00	..GUIDE, SPRING 3	1	1	1	1	
4	3SP-22213-00	..SEAT, SPRING UPPER	1	1	1	1	
5	509-23184-L0	..CAP, AIR VALVE	1	1	1	1	
6	4JX-22226-00	..BUSH, SHOCK ABSORBER LOWER	1	1	1	1	
7	5DH-23183-00	..CIRCLIP	1	1	1	1	
8	4AA-22259-80	..LABEL, WARNING	1				UR FOR USA
	4AA-22259-60	..LABEL, WARNING	1				UR FOR CAN
	4AA-22259-40	..LABEL, WARNING		1		1	
	4AA-22259-50	..LABEL, WARNING			1		
9	5MV-22224-00	.GUIDE, SPRING 2	1	1	1	1	
10	1C3-22253-50	.COLLAR, DISTANCE	2	2	2	2	
11	3JE-22475-00	.SEAL, DUST	2	2	2	2	
12	4EW-22474-00	.SEAL, RING	2	2	2	2	
13	5UN-22176-00	.BEARING	1	1	1	1	
14	5MV-22184-00	.BUSH	1	1	1	1	
15	5MV-22253-00	.COLLAR, DISTANCE	2	2	2	2	
16	5NY-22475-00	.SEAL, DUST	2	2	2	2	
17	1C3-22212-30	.SPRING (K=50N/MM)	1	1	1	1	
18	1C3-22214-50	.GUIDE, SPRING 1	1	1	1	1	
19	1C3-22565-00	.SPRING SEAT	2	2	2	2	

FIG. 24 STEERING

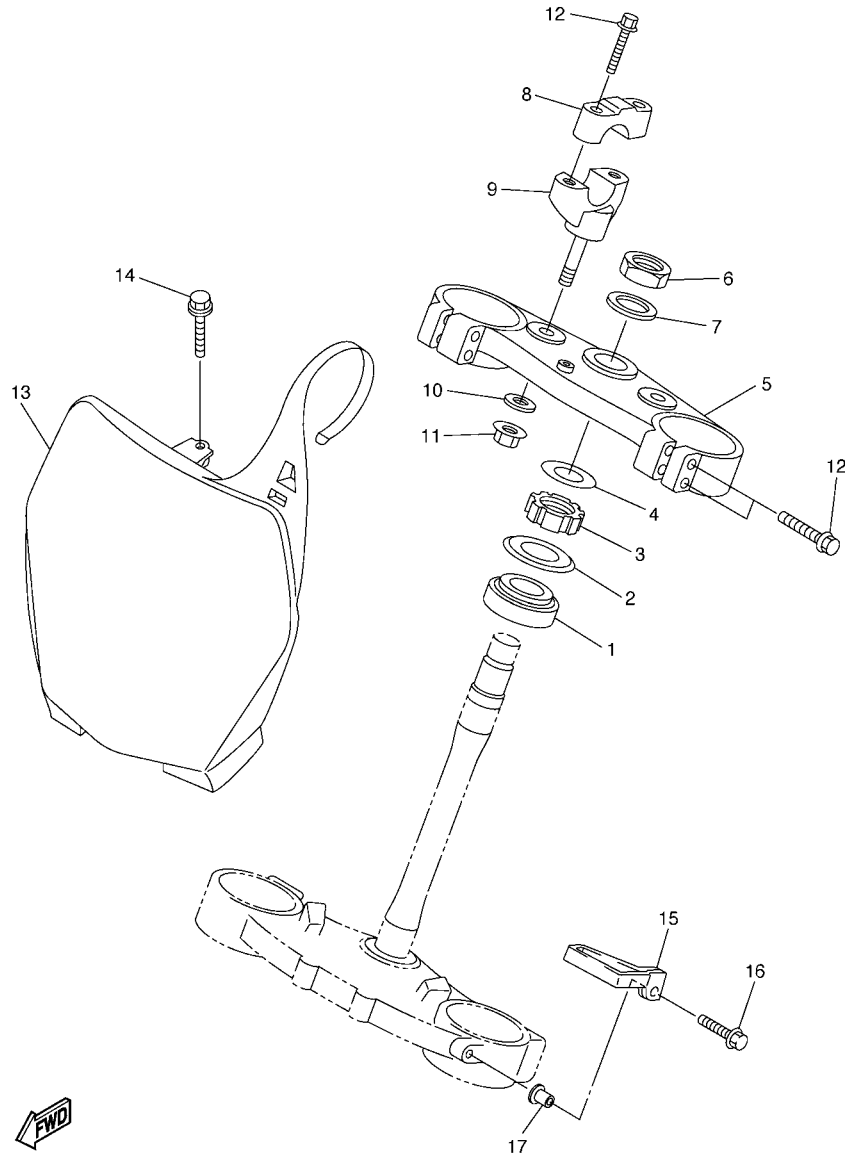

REF. NO.	PART NO.	DESCRIPTION	NOA	EUR	JPN	ANZ	REMARKS
1	93332-00068	BEARING	1	1	1	1	
2	4EW-23416-00	COVER, BALL RACE 2	1	1	1	1	
3	90179-28003	NUT	1	1	1	1	
4	90201-286K9	WASHER, PLATE	1	1	1	1	
5	1C3-23435-50	CROWN, HANDLE	1	1	1	1	
6	90170-24003	NUT	1	1	1	1	
7	90201-24016	WASHER, PLATE	1	1	1	1	
8	5XC-23441-90	HOLDER, HANDLE UPPER	2	2	2	2	
9	5XC-23442-90	HOLDER, HANDLE LOWER	2	2	2	2	
10	90201-12028	WASHER, PLATE	2	2	2	2	
11	95602-12200	NUT, SELF-LOCKING	2	2	2	2	
12	95024-08035	BOLT, FLANGE	8	8	8	8	
13	1C3-23485-60	PLATE, NUMBER	1	1	1	1	
14	90119-06128	BOLT, WITH WASHER	1	1	1	1	
15	5XE-23389-00	GUIDE, CABLE	1	1	1	1	
16	95024-06020	BOLT, FLANGE	1	1	1	1	
17	90387-06104	COLLAR	1	1	1	1	



5XC9100-E240

FIG. 25 FRONT FORK

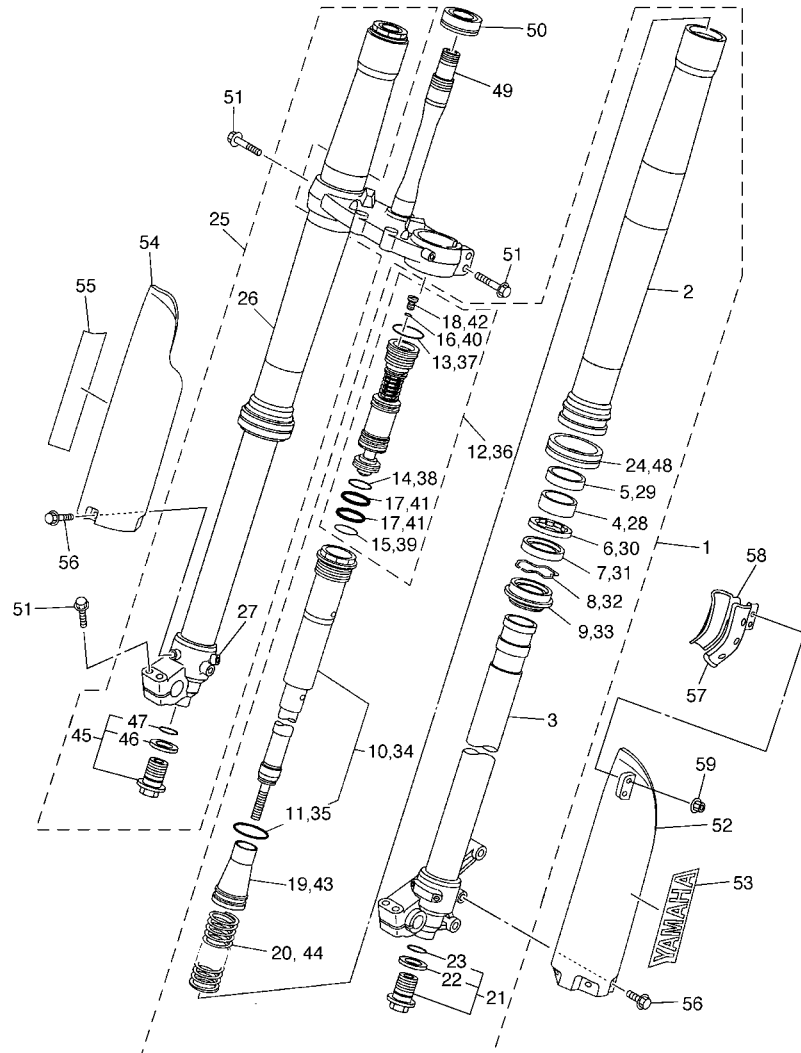

5XC9100-E250

REF. NO.	PART NO.	DESCRIPTION	NOA	EUR	JPN	ANZ	REMARKS
1	5XC-23102-A0	FRONT FORK ASSY (L.H)	1		1	1	
	5XC-23102-B0	FRONT FORK ASSY (L.H)		1			
2	1C3-23136-M0	.TUBE, OUTER (RIGHT)	1	1	1	1	
3	5XC-23120-L0	.INNER TUBE COMP.2	1	1	1	1	
4	5XE-23171-L0	.PISTON, FRONT FORK	1	1	1	1	
5	5XE-23125-L0	.METAL, SLIDE 1	1	1	1	1	
6	5XE-23146-L0	.WASHER, OIL SEAL	1	1	1	1	
7	1C3-23145-M0	.OIL SEAL	1	1	1	1	
8	5XE-23153-L0	.RING, SNAP	1	1	1	1	
9	5XE-23144-L0	.SEAL, DUST	1	1	1	1	
10	1C3-23170-N0	.CYLINDER COMP., FRONT FORK	1	1	1	1	
11	1C3-23147-L0	..O-RING	1	1	1	1	
12	5XC-2316A-R0	.VALVE COMP.	1		1	1	
	1P8-2316A-M0	.VALVE COMP.		1			
13	1C3-23188-L0	..O-RING	1	1	1	1	
14	1C3-23188-N0	..O-RING	1	1	1	1	
15	1C3-23188-P0	..O-RING	1	1	1	1	
16	1C3-23188-R0	..O-RING	1	1	1	1	
17	1AE-23147-00	..O-RING	2	2	2	2	
18	1C3-23190-L0	..AIR VALVE COMP.	1	1	1	1	
19	1C3-23142-L0	.SEAT, SPRING UPPER	1	1	1	1	
20	5XC-23141-M0	.SPRING, FRONT FORK(K=4.3N/MM)	1	1	1	1	
21	1C3-23111-L0	.BOLT, CAP	1	1	1	1	
22	2HH-23158-L0	..GASKET	1	1	1	1	
23	276-23114-00	..GASKET	1	1	1	1	
24	1C3-2314F-M0	.PROTECTOR GUIDE COMP., 1	1	1	1	1	
25	5XC-23103-A0	FRONT FORK ASSY (R.H)	1		1	1	

FIG. 25 FRONT FORK

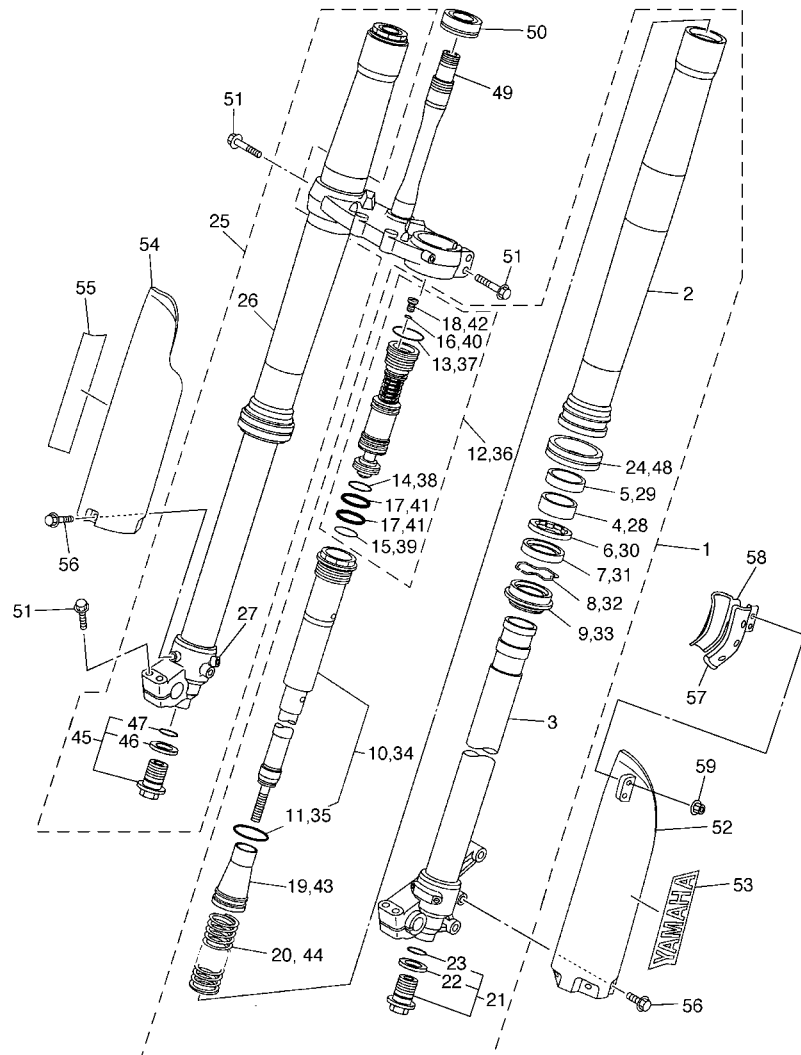

REF. NO.	PART NO.	DESCRIPTION	NOA	EUR	JPN	ANZ	REMARKS
25	5XC-23103-B0	FRONT FORK ASSY (R.H)		1			
26	1C3-23136-M0	.TUBE, OUTER (RIGHT)	1	1	1	1	
27	5XC-23110-L0	.INNER TUBE COMP.1	1	1	1	1	
28	5XE-23171-L0	.PISTON, FRONT FORK	1	1	1	1	
29	5XE-23125-L0	.METAL, SLIDE 1	1	1	1	1	
30	5XE-23146-L0	.WASHER, OIL SEAL	1	1	1	1	
31	1C3-23145-M0	.OIL SEAL	1	1	1	1	
32	5XE-23153-L0	.RING, SNAP	1	1	1	1	
33	5XE-23144-L0	.SEAL, DUST	1	1	1	1	
34	1C3-23170-N0	.CYLINDER COMP., FRONT FORK	1	1	1	1	
35	1C3-23147-L0	..O-RING	1	1	1	1	
36	5XC-2316A-R0	.VALVE COMP.	1		1	1	
	1P8-2316A-M0	.VALVE COMP.		1			
37	1C3-23188-L0	..O-RING	1	1	1	1	
38	1C3-23188-N0	..O-RING	1	1	1	1	
39	1C3-23188-P0	..O-RING	1	1	1	1	
40	1C3-23188-R0	..O-RING	1	1	1	1	
41	1AE-23147-00	..O-RING	2	2	2	2	
42	1C3-23190-L0	..AIR VALVE COMP.	1	1	1	1	
43	1C3-23142-L0	.SEAT, SPRING UPPER	1	1	1	1	
44	5XC-23141-M0	.SPRING, FRONT FORK(K=4.3N/MM)	1	1	1	1	
45	1C3-23111-L0	.BOLT, CAP	1	1	1	1	
46	2HH-23158-L0	..GASKET	1	1	1	1	
47	276-23114-00	..GASKET	1	1	1	1	
48	1C3-2314F-M0	.PROTECTOR GUIDE COMP., 1	1	1	1	1	
49	1C3-23340-M0	UNDER BRACKET COMP.	1	1	1	1	
50	93332-00081	BEARING	1	1	1	1	



5XC9100-E250

FIG. 25 FRONT FORK

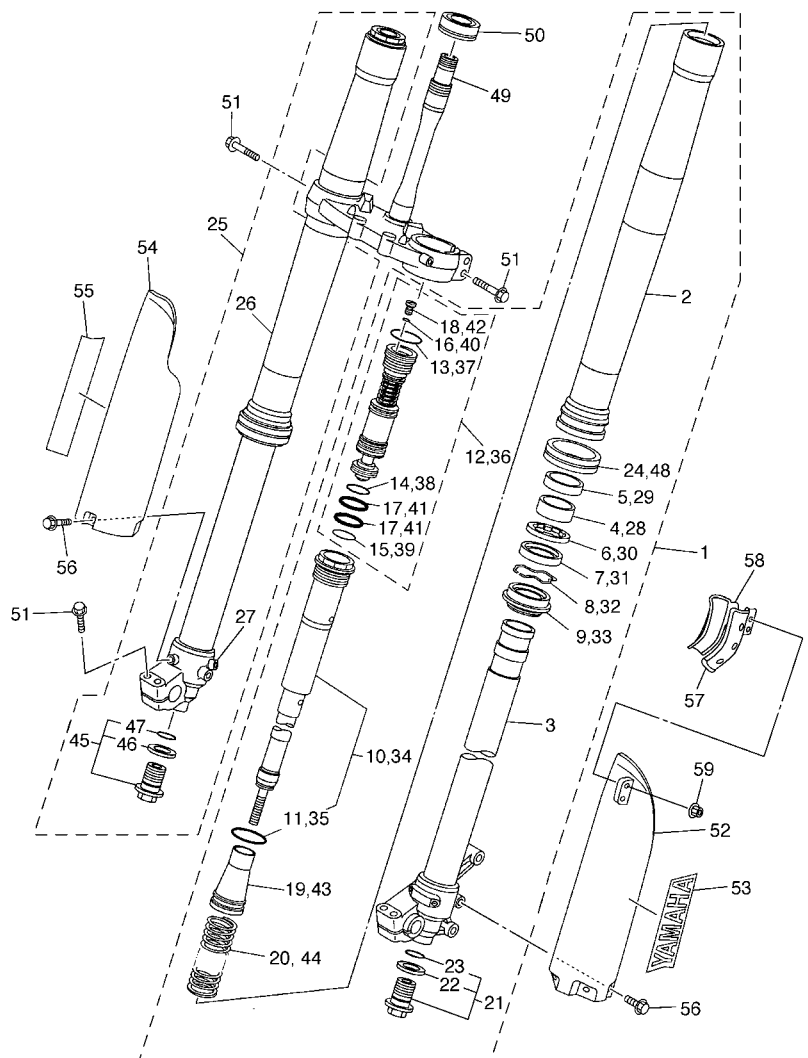

REF. NO.	PART NO.	DESCRIPTION	NOA	EUR	JPN	ANZ	REMARKS
51	5XC-23346-L0	BOLT 1	8	8	8	8	
52	1C3-2315J-10	PROTECTOR 2	1	1	1	1	
53	4XL-2153A-10	EMBLEM, YAMAHA	1	1	1	1	
54	1C3-2315H-10	PROTECTOR 1	1	1	1	1	
55	4XL-2153A-10	EMBLEM, YAMAHA	1	1	1	1	
56	3SP-23356-L0	BOLT 2	6	6	6	6	
57	1C3-23466-50	CLAMP	1	1	1	1	
58	1C3-23467-50	CLAMP	1	1	1	1	
59	95702-06500	NUT, FLANGE	2	2	2	2	



5XC9100-E250

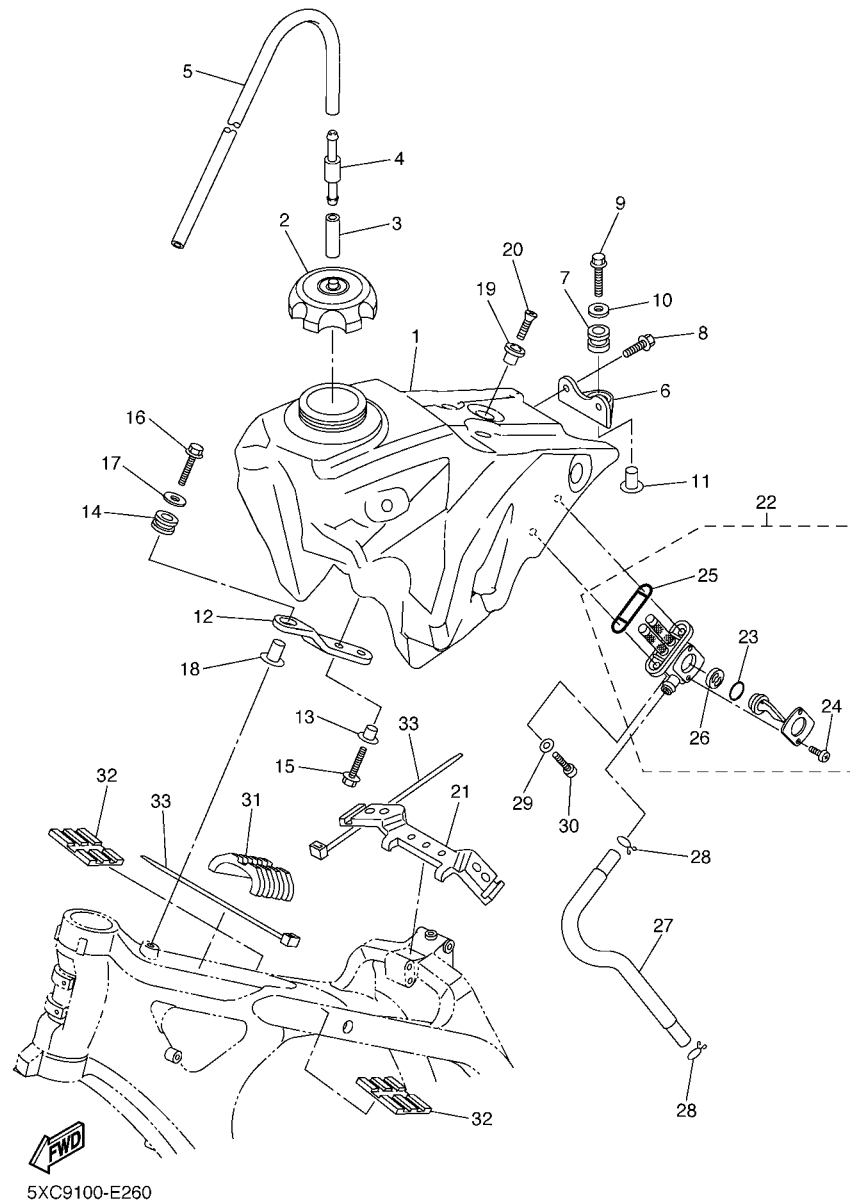

FIG. 26 FUEL TANK

REF. NO.	PART NO.	DESCRIPTION	NOA	EUR	JPN	ANZ	REMARKS
1	5XC-24110-90	FUEL TANK COMP.	1	1	1	1	
2	5NY-24610-00	CAP ASSY	1	1	1	1	
3	90445-09220	HOSE (L30)	1	1	1	1	
4	3XJ-24380-00	PIPE JOINT ASSY	1	1	1	1	
5	90445-09251	HOSE (L350)	1	1	1	1	
6	5XE-24144-00	HOLDER, DAMPER	1	1	1	1	
7	90480-18549	GROMMET	1	1	1	1	
8	95027-06016	BOLT, FLANGE	2	2	2	2	
9	95024-06030	BOLT, FLANGE	1	1	1	1	
10	90201-06570	WASHER, PLATE	1	1	1	1	
11	3JD-24186-00	WASHER, SPECIAL	1	1	1	1	
12	5XC-2419A-90	HOLDER	1	1	1	1	
13	90387-06090	COLLAR	2	2	2	2	
14	5XC-24339-90	GROMMET	1	1	1	1	
15	95027-06016	BOLT, FLANGE	2	2	2	2	
16	95024-06030	BOLT, FLANGE	1	1	1	1	
17	90201-06570	WASHER, PLATE	1	1	1	1	
18	90387-06065	COLLAR	1	1	1	1	
19	4EW-2412F-00	BRACKET, SEAT	1	1	1	1	
20	98707-06025	SCREW, FLAT HEAD	1	1	1	1	
21	5XC-24181-90	DAMPER, LOCATING 1	1	1	1	1	
22	4JT-24500-10	FUEL COCK ASSY 1	1	1	1	1	
23	3AJ-24534-01	.SEAL, COCK	1	1	1	1	
24	98502-03008	.SCREW, PAN HEAD	2	2	2	2	
25	4X8-24512-00	.O-RING	1	1	1	1	
26	3AC-24523-00	.VALVE PACKING	1	1	1	1	
27	5XC-24311-90	PIPE, FUEL 1	1	1	1	1	

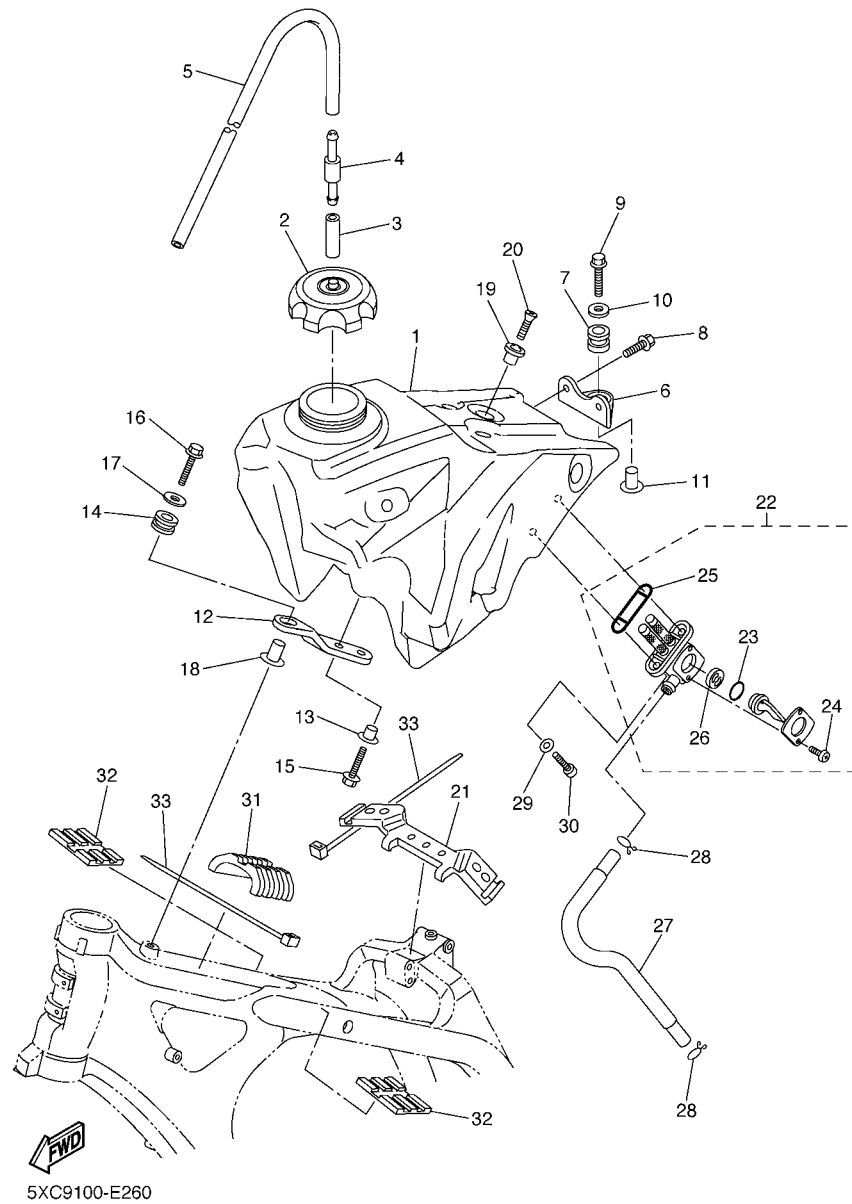
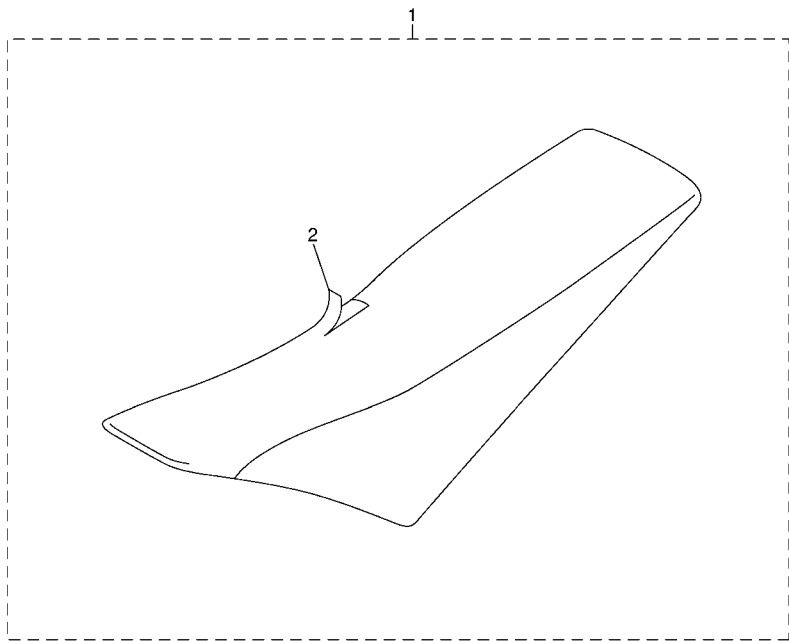

FIG. 26 FUEL TANK

REF. NO.	PART NO.	DESCRIPTION	NOA	EUR	JPN	ANZ	REMARKS
28	90467-100A1	CLIP	2	2	2	2	
29	90202-05193	WASHER, PLATE	2	2	2	2	
30	90149-06011	SCREW	2	2	2	2	
31	5XC-24182-90	DAMPER, LOCATING 2	1	1	1	1	
32	5XC-24183-90	DAMPER, LOCATING 3	2	2	2	2	
33	90465-13275	CLAMP	3	3	3	3	

FIG. 27 SEAT



REF. NO.	PART NO.	DESCRIPTION	NOA	EUR	JPN	ANZ	REMARKS
1	5XC-24710-90	SINGLE SEAT ASSY	1		1	1	UR FOR DPBSE
	5XC-24710-D0	SINGLE SEAT ASSY	1		1	1	UR FOR LRY51
	5XC-24710-A0	SINGLE SEAT ASSY		1			
2	5XC-2470F-90	.SEAT COVER COMP.	1		1	1	UR FOR DPBSE
	5XC-2470F-D0	.SEAT COVER COMP.	1		1	1	UR FOR LRY51
	5XC-2470F-A0	.SEAT COVER COMP.		1			



5XC9100-E270

FIG. 28 FRONT WHEEL

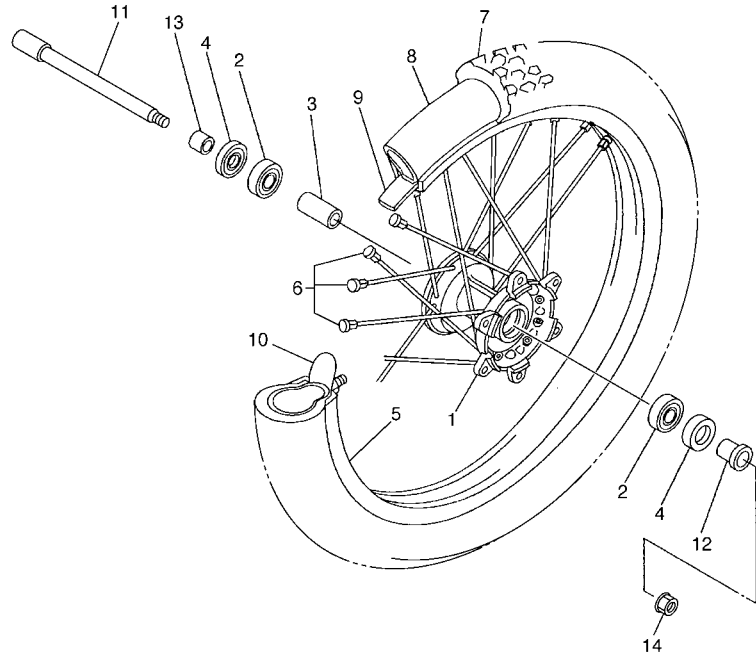

REF. NO.	PART NO.	DESCRIPTION	NOA	EUR	JPN	ANZ	REMARKS
1	5NY-25111-00	HUB, FRONT	1	1	1	1	
2	93306-90409	BEARING	2	2	2	2	
3	5NY-25117-00	SPACER, BEARING	1	1	1	1	
4	93102-26468	OIL SEAL	2	2	2	2	
5	94416-21034	RIM (1.60-21)	1	1	1	1	
6	5NY-25104-00	SPOKE SET, FRONT	1	1	1	1	
7	94108-21015	TIRE (80/100-21 51M D739FA)	1			1	DUNLOP
	*	TIRE (80/100-21 51R MT320)		1			LM PIRELLI
	94108-2112Y	TIRE (80/100-21 51M D755F)		1			DUNLOP FOR FRA
	94108-21012	TIRE(80/100-21 51M M601)			1		BRIDGESTONE
8	94227-21101	TUBE (80/100-21 M/C TR4)	1	1		1	DUNLOP FOR FRA
	*	TUBE (80/100-21)		1			LM PIRELLI
	94209-21229	TUBE (80/100-21 M/C TR4)			1		BRIDGESTONE
9	94309-21161	BAND, RIM (1.60-21)	1	1		1	DUNLOP FOR FRA
	*	BAND, RIM (80/100-21)		1			LM PIRELLI
	94330-21084	BAND,RIM (1.60-21)			1		BRIDGESTONE
10	5SF-25394-00	SPACER, BEAD	1	1	1	1	
11	1C3-25181-10	AXLE, WHEEL	1	1	1	1	
12	5NY-25183-00	COLLAR, WHEEL	1	1	1	1	
13	5NY-25186-00	COLLAR, WHEEL	1	1	1	1	
14	90179-16011	NUT	1	1	1	1	



5XD5100-D280

FIG. 29 FRONT BRAKE CALIPER

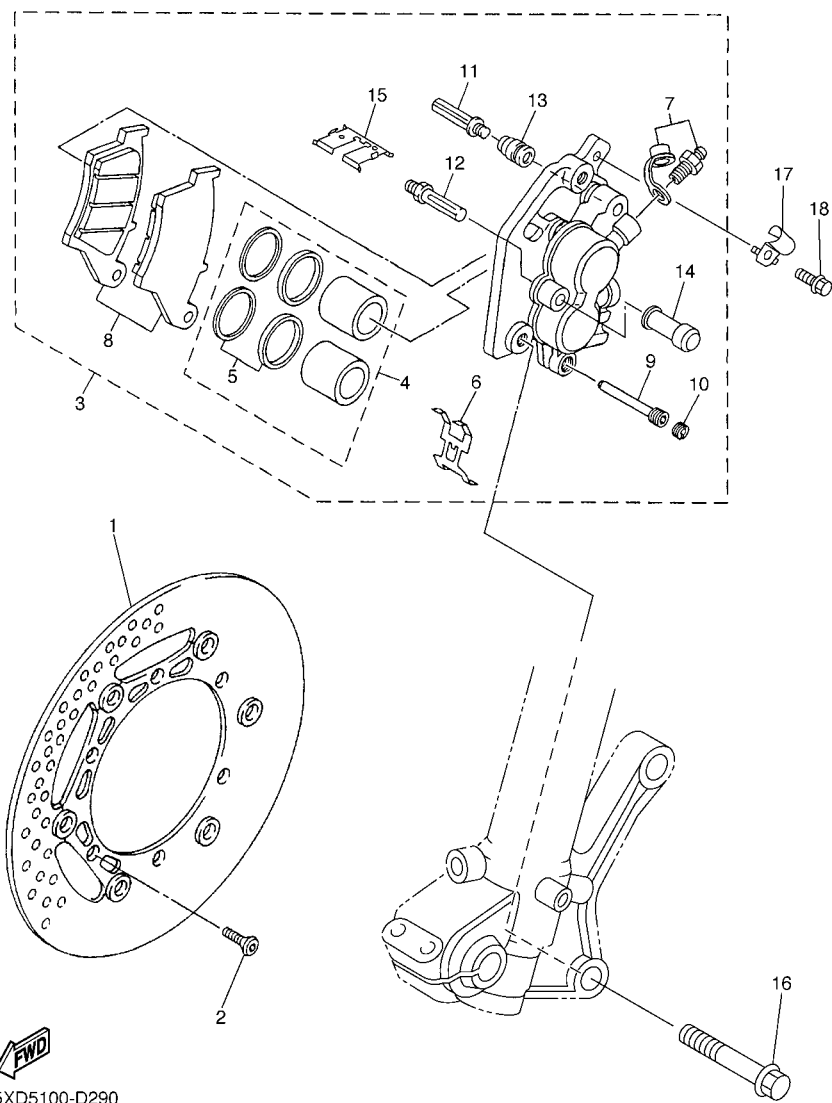

REF. NO.	PART NO.	DESCRIPTION	NOA	EUR	JPN	ANZ	REMARKS
1	5MV-2581T-00	DISK BRAKE ASSY	1	1	1	1	
2	90149-06327	SCREW	6	6	6	6	
3	1C3-2580T-00	CALIPER ASSY (LEFT)	1	1	1	1	
4	5UN-W0057-00	.PISTON ASSY, CALIPER	1	1	1	1	
5	3JD-W0047-00	..CALIPER SEAL KIT	1	1	1	1	
6	5DH-25919-00	.SUPPORT, PAD	1	1	1	1	
7	1UY-W0048-50	.BLEED SCREW KIT	1	1	1	1	
8	5MV-W0045-01	.BRAKE PAD KIT	1	1	1	1	
9	5DH-25933-00	.PIN, PAD	1	1	1	1	
10	5DH-25916-00	.PLUG	1	1	1	1	
11	3SP-25926-51	.BOLT	1	1	1	1	
12	3SP-25914-51	.PIN, SLIDE	1	1	1	1	
13	3JD-25917-00	.BOOT, CALIPER	1	1	1	1	
14	1UY-25937-51	.BOOT 2	1	1	1	1	
15	5DH-25849-00	.RETAINER, CALIPER	1	1	1	1	
16	90105-08077	BOLT, FLANGE	2	2	2	2	
17	1C3-25875-50	HOLDER, BRAKE HOSE 1	1	1	1	1	
18	95024-06010	BOLT, FLANGE	1	1	1	1	

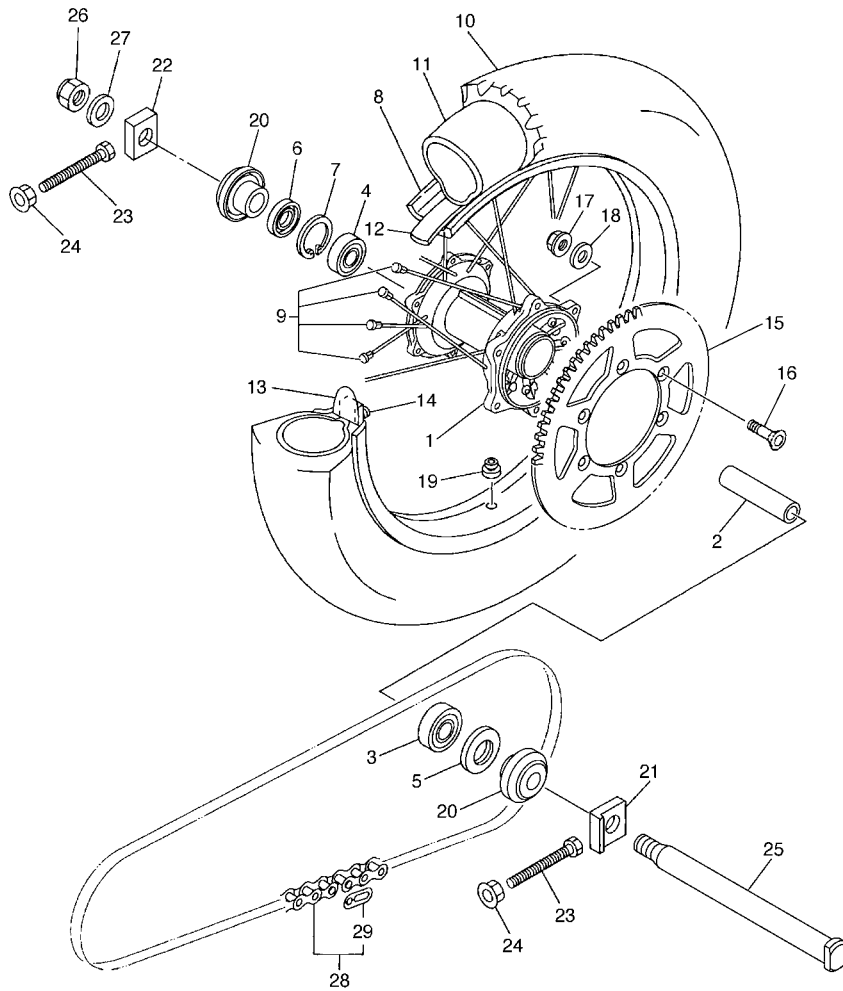

5XC9100-E300

FIG. 30 REAR WHEEL

REF. NO.	PART NO.	DESCRIPTION	NOA	EUR	JPN	ANZ	REMARKS
1	5ET-25311-00	HUB, REAR	1	1	1	1	
2	5ET-25317-00	SPACER, BEARING	1	1	1	1	
3	93306-27212	BEARING	1	1	1	1	
4	93306-07202	BEARING	1	1	1	1	
5	93106-30001	OIL SEAL	1	1	1	1	
6	93106-30045	OIL SEAL	1	1	1	1	
7	99009-45500	CIRCLIP	1	1	1	1	
8	94418-19008	RIM (1.85-19)	1	1	1	1	
9	5HD-25304-00	SPOKE SET, REAR	1	1	1	1	
10	94110-19012	TIRE (100/90-19 57M D756)	1			1	DUNLOP
*		TIRE (100/90-19 MT320)		1			LM PIRELLI
	94110-1913B	TIRE (100/90-19 57M D755)		1			DUNLOP FOR FRA
	94110-19009	TIRE(100/90-19 51M M602)			1		BRIDGESTONE
11	94210-19224	TUBE (100/90-19 M/C TR4 BTL)	1			1	DUNLOP
*		TUBE (110/90-19)		1			LM PIRELLI
	94210-19224	TUBE (100/90-19 M/C TR4 BTL)		1			DUNLOP FOR FRA
	94210-19222	TUBE (100/90-19 M/C TR4)			1		BRIDGESTONE
12	94321-19135	BAND, RIM (1.85-19)	1			1	DUNLOP
*		BAND, RIM (3.50-18)		1			LM METZELER
	94321-19135	BAND, RIM (1.85-19)		1			DUNLOP FOR FRA
	94316-19156	BAND, RIM (1.85-19)			1		BRIDGESTONE
13	4XM-25394-00	SPACER, BEAD	1	1	1	1	
14	4XM-25364-00	DAMPER	1	1	1	1	
15	1C3-25448-00	SPROCKET, DRIVEN (48T)	1			1	UR STD
	1C3-25449-00	SPROCKET, DRIVEN (49T)		1	1		UR STD
	1C3-25447-00	SPROCKET, DRIVEN (47T)	1	1	1	1	AP
	1C3-25448-00	SPROCKET, DRIVEN (48T)		1	1		AP

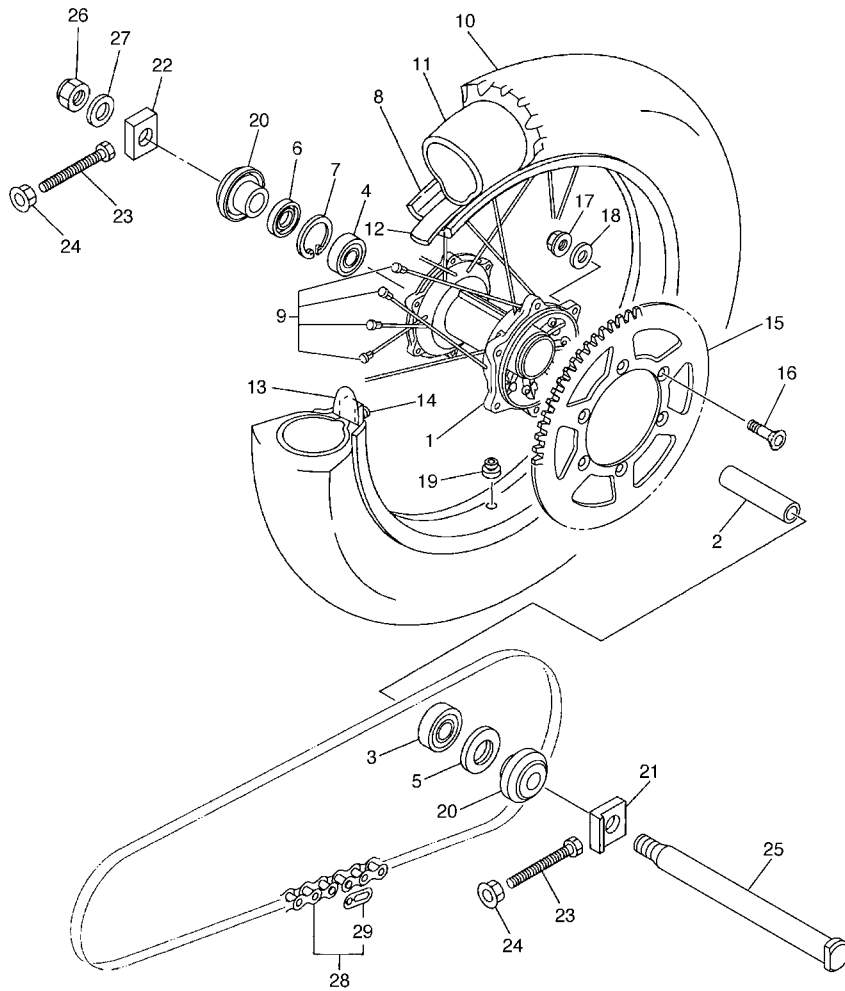

5XC9100-E300

FIG. 30 REAR WHEEL

REF. NO.	PART NO.	DESCRIPTION	NOA	EUR	JPN	ANZ	REMARKS
15	1C3-25449-00	SPROCKET, DRIVEN (49T)	1			1	AP
	1C3-25450-00	SPROCKET, DRIVEN (50T)	1	1	1	1	AP
	1C3-25451-00	SPROCKET, DRIVEN (51T)	1	1	1	1	AP
	1C3-25452-00	SPROCKET, DRIVEN (52T)	1	1	1	1	AP
16	90109-08078	BOLT	6	6	6	6	
17	90185-08008	NUT, SELF-LOCKING	6	6	6	6	
18	90201-08048	WASHER, PLATE	6	6	6	6	
19	90480-08608	GROMMET	1	1	1	1	
20	5TJ-2530S-80	COLLAR ASSY	2	2	2	2	
21	1C3-25388-50	PULLER, CHAIN 1	1	1	1	1	
22	1C3-25389-00	PULLER, CHAIN 2	1	1	1	1	
23	90101-08006	BOLT	2	2	2	2	
24	90179-08656	NUT	2	2	2	2	
25	1C3-25381-10	AXLE, WHEEL	1	1	1	1	
26	90185-20002	NUT, SELF-LOCKING	1	1	1	1	
27	90201-20020	WASHER, PLATE	1	1	1	1	
28	9Y581-92111	CHAIN (DID 520D 112L)	1	1	1	1	
29	94681-68001	.JOINT,CHAIN (DID 520DM-RJ)	1	1	1	1	

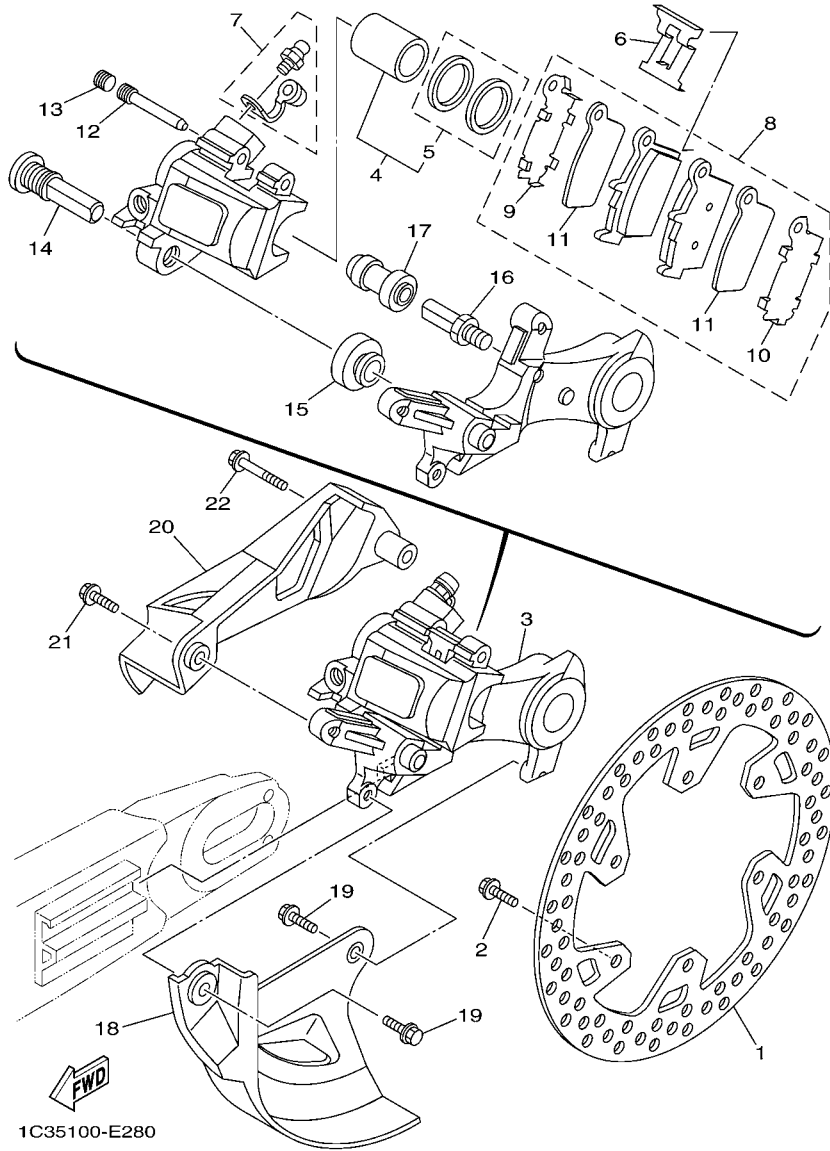
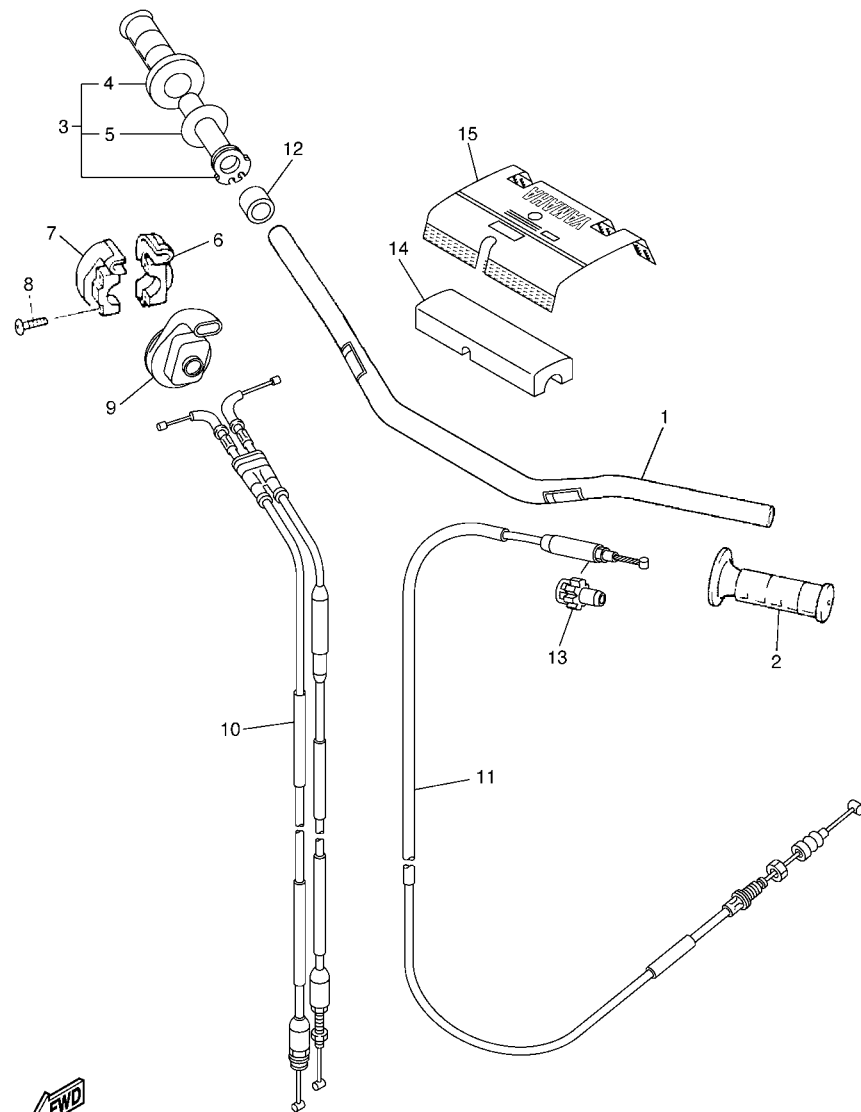

FIG. 31 REAR BRAKE CALIPER

REF. NO.	PART NO.	DESCRIPTION	NOA	EUR	JPN	ANZ	REMARKS
1	5NY-2582W-00	DISK, REAR BRAKE 2	1	1	1	1	
2	90109-065G4	BOLT	6	6	6	6	
3	1C3-2580W-50	CALIPER ASSY, REAR 2	1	1	1	1	
4	5UN-W0057-50	.PISTON ASSY, CALIPER	1	1	1	1	
5	5UN-W0047-50	..CALIPER SEAL KIT	1	1	1	1	
6	5DH-25919-50	..SUPPORT, PAD	1	1	1	1	
7	1UY-W0048-50	.BLEED SCREW KIT	1	1	1	1	
8	1C3-W0046-50	.BRAKE PAD KIT 2	1	1	1	1	
9	5UN-25828-60	..SHIM, CALIPER	1	1	1	1	
10	5UN-25827-60	..SHIM, CALIPER	1	1	1	1	
11	5UN-22898-60	..INSULATOR, HEAT	2	2	2	2	
12	8CR-25924-00	.PIN, PAD	1	1	1	1	
13	5DH-25916-00	.PLUG	1	1	1	1	
14	5DH-25914-50	.PIN, SLIDE	1	1	1	1	
15	3JD-25917-00	.BOOT, CALIPER	1	1	1	1	
16	5UN-25914-00	.PIN, SLIDE	1	1	1	1	
17	1UY-25937-51	.BOOT 2	1	1	1	1	
18	1C3-25718-50	PROTECTOR, DISK BRAKE	1	1	1	1	
19	95022-06012	BOLT, FLANGE	2	2	2	2	
20	1C3-27491-50	PROTECTOR	1	1	1	1	
21	95024-06016	BOLT, FLANGE	1	1	1	1	
22	95024-06030	BOLT, FLANGE	1	1	1	1	



5XC9100-E320

FIG. 32 STEERING HANDLE & CABLE

REF. NO.	PART NO.	DESCRIPTION	NOA	EUR	JPN	ANZ	REMARKS
1	5XC-26111-90	HANDLEBAR	1	1	1	1	
2	4GY-26241-00	GRIP	1	1	1	1	
3	5TJ-26240-C0	GRIP ASSY	1	1	1	1	
4	4GY-26242-00	.GRIP (RIGHT)	1	1	1	1	
5	3Y1-26249-00	.RING, LEAF	1	1	1	1	
6	5BE-26281-00	CAP, GRIP UPPER	1	1	1	1	
7	5BE-26282-00	CAP, GRIP LOWER	1	1	1	1	
8	98507-05020	SCREW, PAN HEAD	2	2	2	2	
9	5SF-26287-10	COVER, CAP GRIP	1	1	1	1	
10	5XC-26302-90	THROTTLE CABLE ASSY	1	1	1	1	
11	5XC-26335-90	CABLE, CLUTCH	1	1	1	1	
12	90387-225N2	COLLAR	1	1	1	1	
13	1C3-26342-50	BOOT, CABLE	1	1	1	1	
14	5XC-26124-90	PROTECTOR, HANDLEBAR	1	1	1	1	
15	5XC-26143-90	COVER, HANDLEBAR UPPER 1	1	1	1	1	UR FOR DPBSE
	5XC-26143-D0	COVER, HANDLEBAR UPPER 1	1		1	1	UR FOR LRYS1

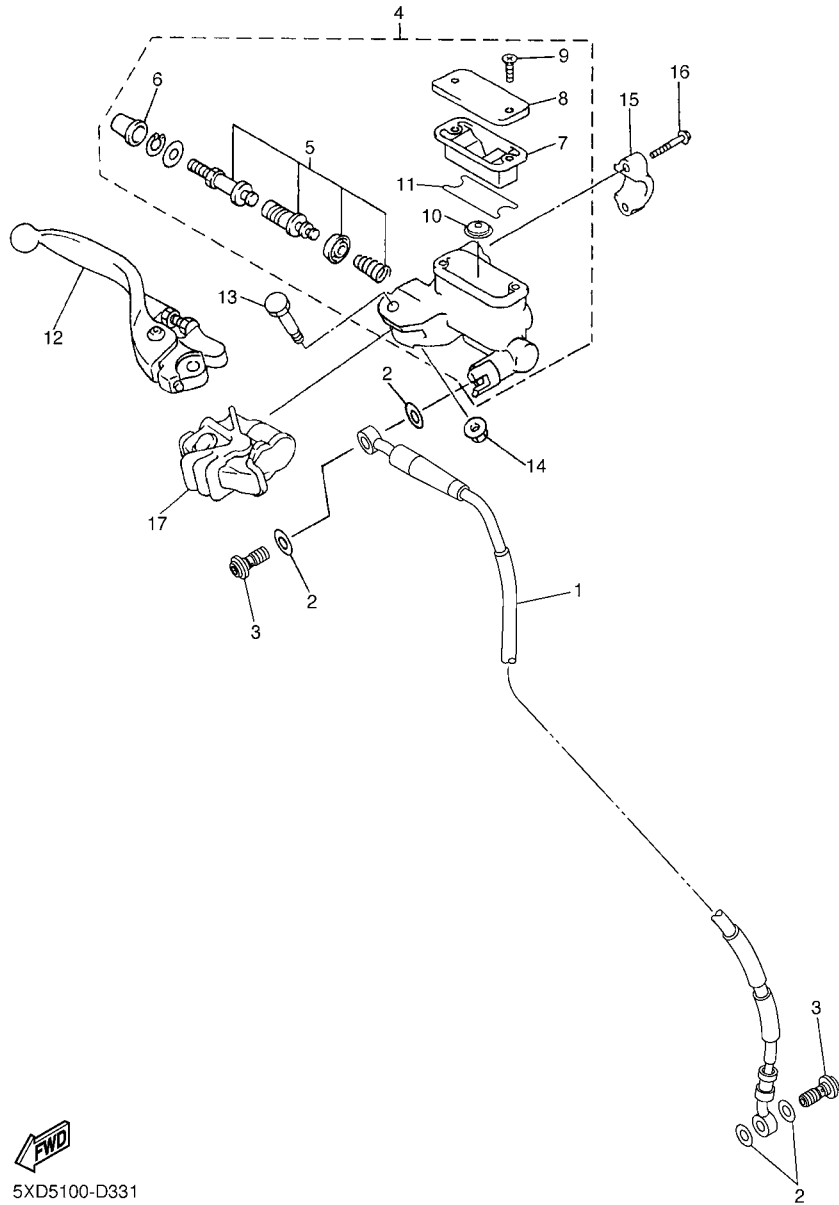

5XD5100-D331

FIG. 33 FRONT MASTER CYLINDER

REF. NO.	PART NO.	DESCRIPTION	NOA	EUR	JPN	ANZ	REMARKS
1	1C3-25872-50	HOSE, BRAKE 1	1	1	1	1	
2	90201-10118	WASHER, PLATE	4	4	4	4	
3	90401-10172	BOLT, UNION	2	2	2	2	
4	5XE-W2587-10	MASTER CYLINDER SUB ASSY	1	1	1	1	
5	5NY-W0041-00	.CYLINDER KIT, MASTER	1	1	1	1	
6	5NY-25868-00	.BOOT, MASTER CYLINDER	1	1	1	1	
7	5XE-25854-00	.DIAPHRAGM, RESERVOIR	1	1	1	1	
8	5MV-25852-01	.CAP, RESERVOIR	1	1	1	1	
9	98706-04012	.SCREW, FLAT HEAD	2	2	2	2	
10	5CG-25715-00	.SEPARATOR ASSY	1	1	1	1	
11	5XE-25853-00	.FLOAT, RESERVOIR	1	1	1	1	
12	1C3-83922-50	LEVER 2	1	1	1	1	
13	5MV-2589F-00	BOLT, LEVER	1	1	1	1	
14	95701-06500	NUT, FLANGE	1	1	1	1	
15	5MV-25867-00	BRACKET, MASTER CYLINDER	1	1	1	1	
16	5MV-25833-00	BOLT, FITTING	2	2	2	2	
17	5NY-26372-00	COVER, HANDLE LEVER 1	1	1	1	1	

FIG. 34 STAND & FOOTREST

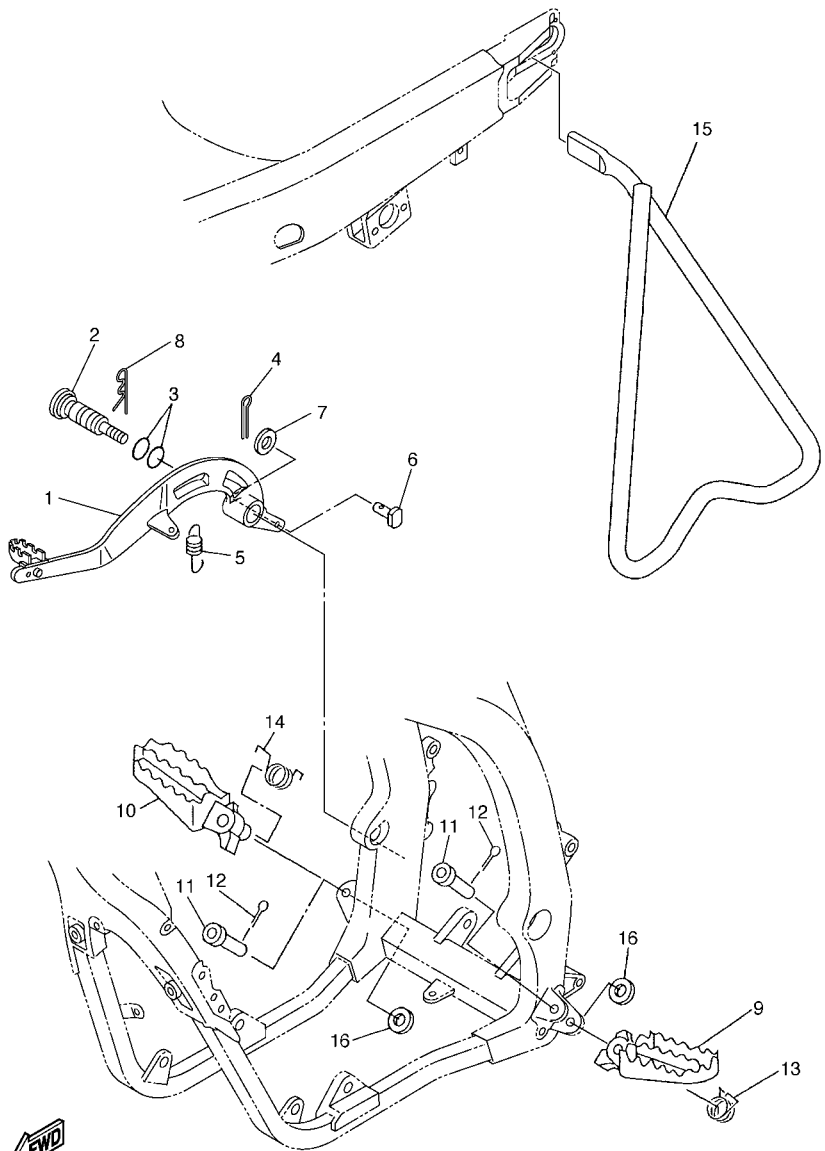

5XC9100-E340

REF. NO.	PART NO.	DESCRIPTION	NOA	EUR	JPN	ANZ	REMARKS
1	5XC-27200-91	PEDAL, BRAKE	1	1	1	1	
2	5XC-27217-90	BOLT	1	1	1	1	
3	93210-11073	O-RING	2	2	2	2	
4	91402-20012	PIN, COTTER	1	1	1	1	
5	90506-16007	SPRING, TENSION	1	1	1	1	
6	90240-08120	PIN, CLEVIS	1	1	1	1	
7	90201-08044	WASHER, PLATE	1	1	1	1	
8	90468-16001	CLIP	1	1	1	1	
9	5XE-27411-01	FOOTREST 1	1	1	1	1	
10	5XE-27421-01	FOOTREST 2	1	1	1	1	
11	90240-10004	PIN, CLEVIS	2	2	2	2	
12	91402-25015	PIN, COTTER	2	2	2	2	
13	90508-28015	SPRING, TORSION	1	1	1	1	
14	90508-28018	SPRING, TORSION	1	1	1	1	
15	1C3-27311-00	STAND, SIDE	1	1	1	1	
16	90201-10032	WASHER, PLATE	2	2	2	2	

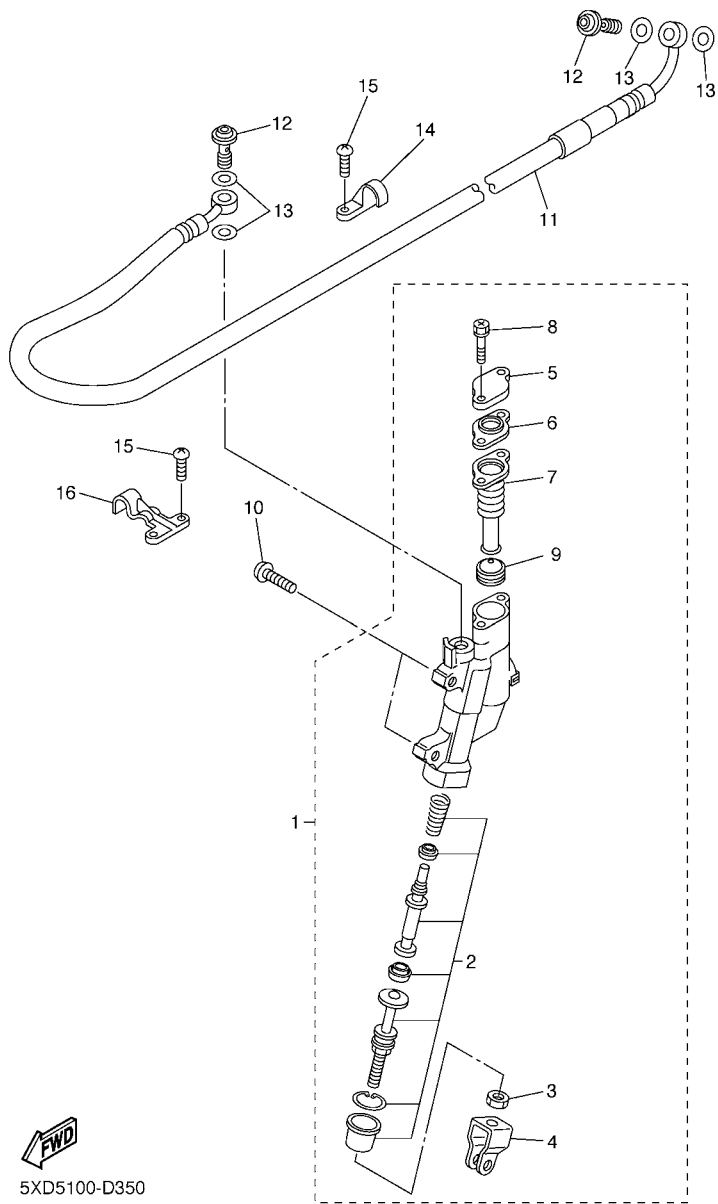

5XD5100-D350

FIG. 35 REAR MASTER CYLINDER

REF. NO.	PART NO.	DESCRIPTION	NOA	EUR	JPN	ANZ	REMARKS
1	1C3-2583V-00	RR. MASTER CYLINDER ASSY.	1	1	1	1	
2	5UN-W0042-50	.CYLINDER KIT, MASTER	1	1	1	1	
3	5UN-27218-00	.NUT	1	1	1	1	
4	5UN-27222-00	.JOINT	1	1	1	1	
5	5UN-25852-50	.CAP, RESERVOIR	1	1	1	1	
6	5UN-2585B-00	.PLATE, DIAPHRAGM	1	1	1	1	
7	5UN-25854-00	.DIAPHRAGM, RESERVOIR	1	1	1	1	
8	5UN-27217-00	.BOLT	2	2	2	2	
9	5CG-25715-00	.SEPARATOR ASSY	1	1	1	1	
10	90111-06059	BOLT,HEX. SOCKET BUTTON	2	2	2	2	
11	1C3-25873-00	HOSE, BRAKE 2	1	1	1	1	
12	90401-10172	BOLT, UNION	2	2	2	2	
13	90201-10118	WASHER, PLATE	4	4	4	4	
14	1C3-25886-50	HOLDER, BRAKE HOSE	1	1	1	1	
15	98504-05010	SCREW, PAN HEAD	4	4	4	4	
16	1C3-25876-50	HOLDER, BRAKE HOSE 2	1	1	1	1	

FIG. 36 GENERATOR

REF. NO.	PART NO.	DESCRIPTION	NOA	EUR	JPN	ANZ	REMARKS
1	5XC-85560-00	BASE ASSY	1	1	1	1	
2	5TA-85550-00	ROTOR ASSY	1	1	1	1	
3	90149-06324	SCREW	3	3	3	3	
4	90179-12657	NUT	1	1	1	1	
5	90201-127E1	WASHER, PLATE	1	1	1	1	
<hr style="border-top: 1px dashed black;"/>							
<hr style="border-top: 1px dashed black;"/>							
<hr style="border-top: 1px dashed black;"/>							
<hr style="border-top: 1px dashed black;"/>							
<hr style="border-top: 1px dashed black;"/>							
<hr style="border-top: 1px dashed black;"/>							

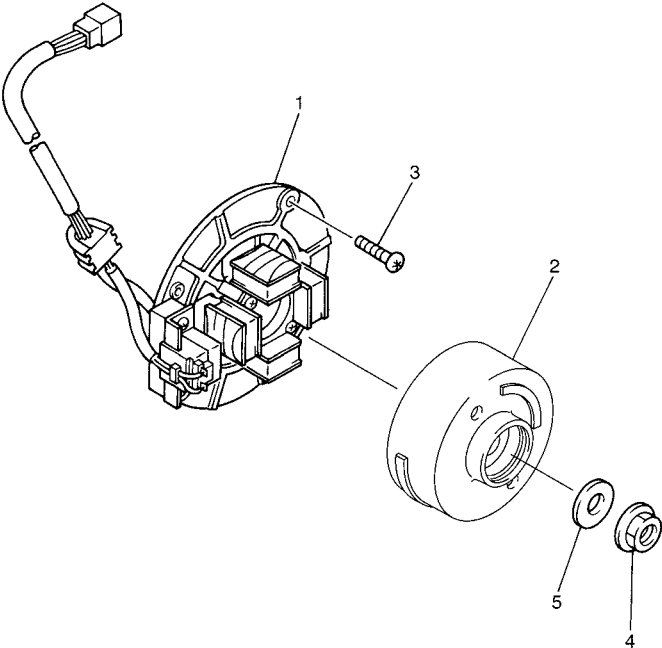

FWD
5TA1100-B360

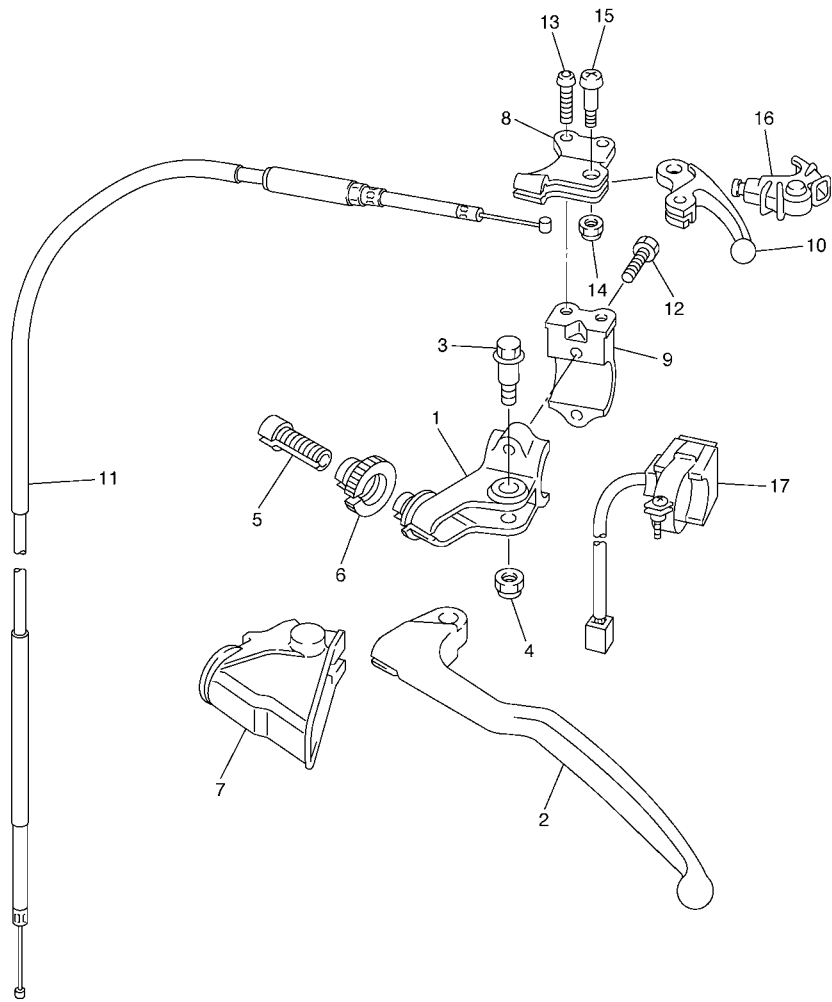

5XC9100-E370

FIG. 37 HANDLE SWITCH & LEVER

REF. NO.	PART NO.	DESCRIPTION	NOA	EUR	JPN	ANZ	REMARKS
1	5XE-82911-00	HOLDER, LEVER 1	1	1	1	1	
2	5MV-83912-00	LEVER 1	1	1	1	1	
3	90109-06034	BOLT	1	1	1	1	
4	5LP-84126-10	NUT, LENS FITTING	1	1	1	1	
5	5HD-26337-00	BOLT, ADJUSTING	1	1	1	1	
6	5HD-83951-00	BOLT, CABLE ADJUSTING	1	1	1	1	
7	5HD-26372-00	COVER, HANDLE LEVER 1	1	1	1	1	
8	5XD-82946-00	HOLDER, STARTER LEVER	1	1	1	1	
9	5XD-82913-00	HOLDER, LEVER LOWER 1	1	1	1	1	
10	5TA-83941-00	LEVER, STARTER	1	1	1	1	
11	5XC-26334-90	CABLE, STARTER 2	1	1	1	1	
12	90101-05033	BOLT	2	2	2	2	
13	92014-05012	BOLT, BUTTON HEAD	2	2	2	2	
14	95607-05100	NUT, U	1	1	1	1	
15	90149-05162	SCREW	1	1	1	1	
16	5TA-26339-00	BOOT	1	1	1	1	
17	1C3-83976-00	SWITCH, HANDLE 1	1	1	1	1	

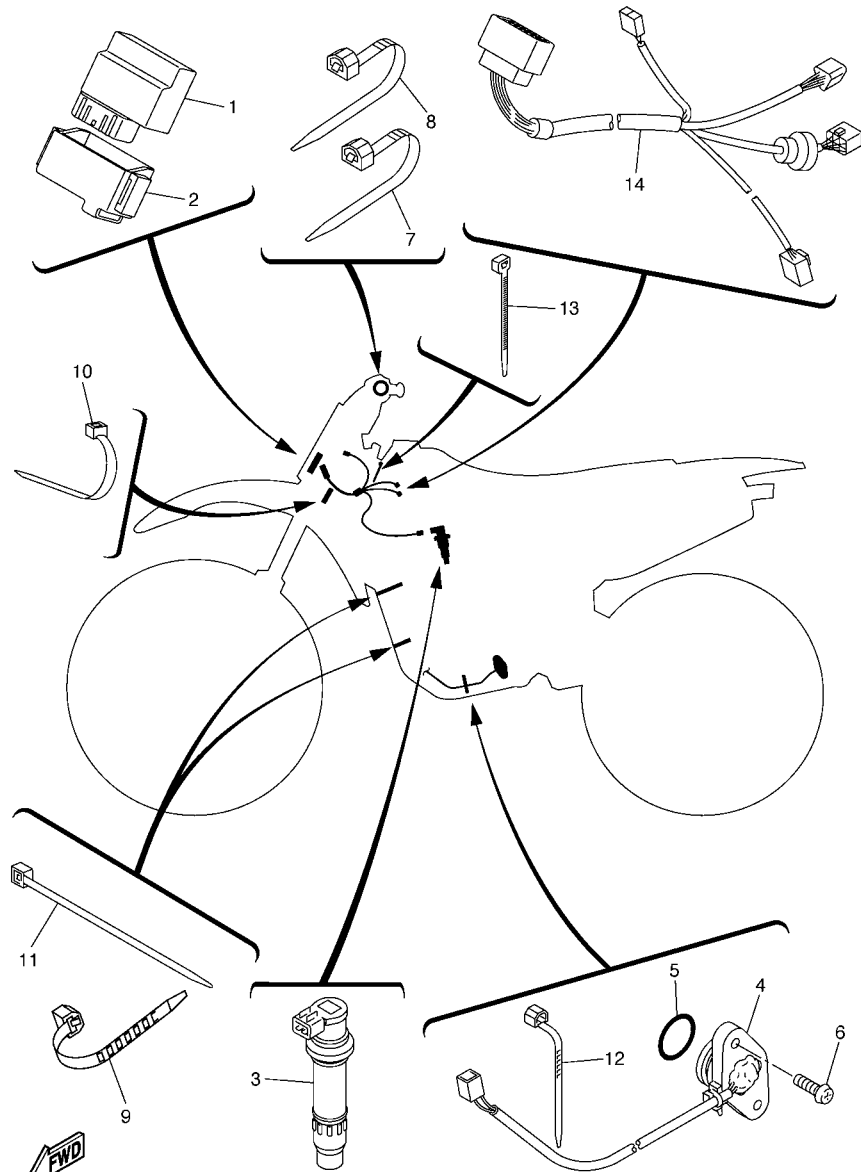

5XC9100-E380

FIG. 38 ELECTRICAL 1

REF. NO.	PART NO.	DESCRIPTION	NOA	EUR	JPN	ANZ	REMARKS
1	5XC-85540-90	C.D.I. UNIT ASSY	1				
	5XC-85540-A0	C.D.I. UNIT ASSY		1	1	1	
2	1C3-85546-00	BAND	1	1	1	1	
3	5UL-82310-10	IGNITION COIL ASSY	1	1	1	1	
4	5XC-82540-00	NEUTRAL SWITCH ASSY	1	1	1	1	
5	93210-21276	O-RING	1	1	1	1	
6	90154-05026	SCREW, BINDING	2	2	2	2	
7	90464-13077	CLAMP	1	1	1	1	
8	90464-13073	CLAMP	1	1	1	1	
9	90464-15195	CLAMP	1	1	1	1	
10	5Y9-12491-00	CLAMP 1	1	1	1	1	
11	90465-13275	CLAMP	4	4	4	4	
12	5Y9-12491-00	CLAMP 1	2	2	2	2	
13	90465-13275	CLAMP	1	1	1	1	
14	5XC-82509-00	WIRE, SUB LEAD	1	1	1	1	

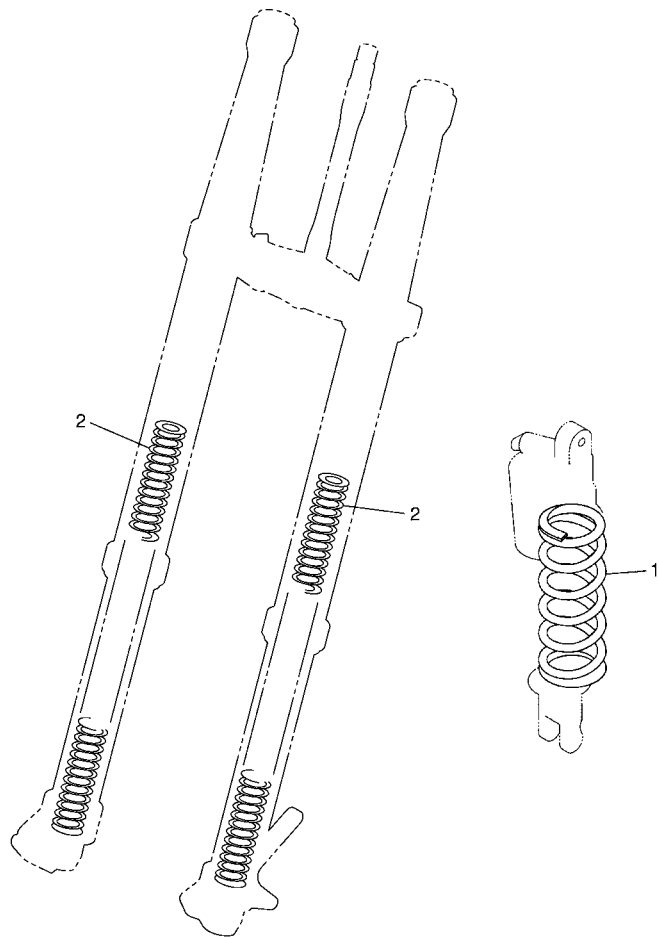

FIG. 39 ALTERNATE FOR CHASSIS

REF. NO.	PART NO.	DESCRIPTION	NOA	EUR	JPN	ANZ	REMARKS
1	5UN-22212-00	SPRING (K=42N/MM)	1	1	1	1	AP
	1C3-22212-00	SPRING (K=44N/MM)	1	1	1	1	AP
	1C3-22212-10	SPRING (K=46N/MM)	1	1	1	1	AP
	1C3-22212-20	SPRING (K=48N/MM)	1	1	1	1	AP
	1C3-22212-40	SPRING (K=52N/MM)	1	1	1	1	AP
	1C3-22212-50	SPRING (K=54N/MM)	1	1	1	1	AP
	1C3-22212-60	SPRING (K=55.8N/MM)	1	1	1	1	AP
	5UN-22212-A0	SPRING (K=APPROX.44N/MM)	1	1	1	1	AP
	5UN-22212-B0	SPRING (K=APPROX.46N/MM)	1	1	1	1	AP
	5UN-22212-C0	SPRING (K=APPROX.48N/MM)	1	1	1	1	AP
	5UN-22212-D0	SPRING (K=APPROX.50N/MM)	1	1	1	1	AP
	5UN-22212-E0	SPRING (K=APPROX.52N/MM)	1	1	1	1	AP
	5UN-22212-F0	SPRING (K=APPROX.54N/MM)	1	1	1	1	AP
	5UN-22212-G0	SPRING (K=APPROX.56N/MM)	1	1	1	1	AP
2	1C3-23141-A0	SPRING, FRONT FORK(K=3.9N/MM)	2	2	2	2	AP
	1C3-23141-B0	SPRING, FRONT FORK(K=4.0N/MM)	2	2	2	2	AP
	1C3-23141-C0	SPRING, FRONT FORK(K=4.1N/MM)	2	2	2	2	AP
	1C3-23141-D0	SPRING, FRONT FORK(K=4.2N/MM)	2	2	2	2	AP
	1C3-23141-F0	SPRING, FRONT FORK(K=4.4N/MM)	2	2	2	2	AP
	1C3-23141-G0	SPRING, FRONT FORK(K=4.5N/MM)	2	2	2	2	AP
	1C3-23141-H0	SPRING, FRONT FORK(K=4.6N/MM)	2	2	2	2	AP
	1C3-23141-J0	SPRING, FRONT FORK(K=4.7N/MM)	2	2	2	2	AP



5XC9100-E390

NUMERICAL INDEX

PART NO.	GRID NO.	PART NO.	GRID NO.	PART NO.	GRID NO.	PART NO.	GRID NO.	PART NO.	GRID NO.	PART NO.	GRID NO.
5XC-11102-10	B - 2	1HX-12168-M1	B - 5	5XC-13416-90	D - 6	5JG-14531-00	C - 4	4MX-14943-43	B - 15	5XD-15378-00	C - 8
4KG-1111G-00	B - 2	1HX-12168-R1	B - 5	5TA-13440-00	B - 12	3TJ-14536-40	C - 3	4MX-14943-44	B - 15	4JT-15381-01	C - 6
5NL-11133-10	B - 2	1HX-12168-U1	B - 5	5BE-13447-10	B - 12	5JG-14546-01	B - 14	4MX-14943-91	B - 15	5BE-15383-01	C - 6
5NL-11134-10	B - 2	1HX-12168-W1	B - 5	5XC-13464-10	B - 10	676-14548-00	C - 2	4MX-14943-92	B - 15	5NL-15388-00	C - 6
5TA-11166-00	B - 2	1HX-12168-Y1	B - 5	5XC-13465-10	B - 10	4MX-14561-00	C - 3	4MX-14943-93	B - 15	5NL-15411-10	C - 7
371-11167-01	B - 2	1HX-12169-11	B - 6	5XC-13597-10	B - 13	6H4-14561-00	C - 3	4MX-14943-94	B - 15	5NL-15415-00	C - 7
5NL-11181-00	B - 2	1HX-12169-31	B - 6	5XC-14101-90	B - 14	5NX-14562-00	C - 3	4MX-14943-95	B - 15	5BE-15421-10	C - 6
5NL-11191-20	B - 2	1HX-12169-50	B - 6	5XC-14101-A0	B - 14	5JG-14565-00	C - 4	5JG-14947-00	B - 15	5XC-15431-00	C - 7
5NL-11193-00	B - 3	1HX-12169-70	B - 6	5NL-14105-00	C - 2	5NL-14591-00	C - 4	4MX-14948-02	B - 15	5NL-15441-01	C - 6
5XC-11311-01	B - 3	1HX-12169-90	B - 6	4MX-14115-00	C - 3	688-14592-00	B - 14	4MX-14948-03	B - 15	5NL-15451-00	C - 7
5NL-11351-00	B - 3	1HX-12169-E0	B - 6	3TJ-14137-40	B - 13	5XC-14611-10	C - 5	4MX-14948-04	B - 15	5NL-15453-00	C - 7
5UM-11387-00	B - 3	1HX-12169-G0	B - 6		C - 3	5NL-14613-00	C - 5	4MX-14948-05	B - 15	5NL-15462-00	C - 7
5XC-11400-10	B - 4	1HX-12169-J0	B - 6	5BE-14146-00	C - 3	5XC-14628-00	C - 5	4MX-14948-06	B - 15	5NL-15601-10	C - 9
5UL-11412-10	B - 4	1HX-12169-L0	B - 6	5PA-14146-00	C - 4	5XC-1469A-00	C - 5	4JT-1494F-07	C - 2	5XC-15620-00	C - 9
5UL-11422-00	B - 4	1HX-12169-N0	B - 6	5TA-14155-00	C - 3	5XC-1469A-10	C - 5	4JT-1494F-09	C - 2	5XC-15621-00	C - 9
5NL-11454-00	B - 4	1HX-12169-T0	B - 6	633-14159-00	C - 2	2S2-1469E-00	C - 5	4JT-1494F-11	C - 2	5NL-15641-10	C - 9
5NL-11455-00	B - 4	5UL-12170-10	B - 7	3TJ-14159-40	B - 14	2S2-1469F-00	C - 5	3TJ-1494F-13	B - 15	5NL-15651-00	C - 9
5NL-11531-00	B - 4	5UL-12180-10	B - 7	5XC-14171-00	C - 3	5XD-14714-00	C - 5	4JT-1494F-13	C - 2	5NL-15664-00	C - 9
5NL-11536-00	B - 4	5TA-12210-20	B - 7	3TJ-14191-40	C - 2	5BE-14747-00	C - 5	3TJ-1494F-14	B - 15	5SG-15668-00	C - 9
5NL-11603-00	B - 4	4FM-12213-00	B - 7	5UL-14196-00	C - 3	5XC-14750-00	C - 5	3TJ-1494F-15	B - 15	4GY-15671-00	C - 9
5NL-11631-20	B - 4	5BE-12241-00	B - 7	5TA-14197-00	C - 3	5XC-14750-10	C - 5	4JT-1494F-15	C - 2	214-15686-00	C - 9
5NL-11633-00	B - 4	5NL-12251-10	B - 7	5NX-14216-00	C - 3	4BD-14766-00	C - 5	3TJ-1494F-16	B - 15	5NL-16111-00	C - 10
5XC-11651-00	B - 4	5NL-12252-00	B - 7	5TA-14227-00	B - 13	5BE-14788-00	C - 5	3TJ-1494F-17	B - 15	5NL-16150-10	C - 10
5XC-11681-00	B - 4	5XC-1240A-90	B - 9	5TA-14239-00	B - 13	5JG-14916-E1	B - 14	4JT-1494F-17	C - 2	5NL-16154-00	C - 10
5NL-12111-10	B - 5	5NL-12422-10	B - 8	5TA-14261-00	C - 3	5NL-14916-E1	B - 14	3TJ-1494F-18	B - 15	3XJ-16321-00	C - 10
5NL-12112-10	B - 5	5NL-12439-00	B - 8	5JG-14264-00	B - 15	5JG-14916-EL	B - 14	3TJ-1494F-19	C - 2	5DH-16321-00	C - 10
5NL-12113-00	B - 5	5XC-1244H-90	B - 9	3TJ-14267-40	B - 14	5JG-14916-EM	B - 14	4JT-1494F-19	C - 2	5NL-16325-00	C - 10
5NL-12114-00	B - 5	5DH-12451-00	B - 8	5JG-14275-00	B - 15	5NL-14916-EM	B - 14	4JT-1494F-21	C - 2	5NL-16325-10	C - 10
5NL-12116-00	B - 5	5XC-12459-00	B - 8	5TA-14293-00	B - 13	5JG-14916-EN	B - 14	4JT-1494F-23	C - 2	5HD-16351-00	C - 10
1HX-12117-00	B - 5	5XC-12461-90	B - 9	3TJ-14293-40	C - 2	5NL-14916-EN	B - 14	4JT-1494F-25	C - 2	5NL-16356-00	C - 10
1WG-12117-00	B - 5	22W-12462-00	B - 9	5TA-14335-00	C - 3	5JG-14916-EP	B - 14	4JT-1494F-27	C - 2	5NL-16357-10	C - 10
1HX-12118-00	B - 5	5XC-12481-90	B - 9	5JG-14346-00	C - 3	5NL-14916-EP	B - 14	4JT-1494F-28	C - 2	5NL-16371-00	C - 10
1WG-12118-00	B - 5	1C3-12482-00	B - 9	5TA-14371-00	C - 3	5JG-14916-ER	B - 14	4JT-1494F-29	C - 2	5JG-16381-00	C - 10
4SV-12119-00	B - 5	5XC-12482-90	B - 9	5TA-14374-00	C - 3	5NL-14916-ER	B - 14	4JT-1494F-30	C - 2	5NL-16383-10	C - 10
4TV-12119-00	B - 5	5Y9-12491-00	F - 2	5JG-14379-00	C - 3	5JG-14916-ES	B - 14	5JG-14951-00	B - 14	4JT-16384-00	C - 10
5NL-12121-10	B - 5	5NL-12564-00	C - 7	5JG-14388-10	B - 14	5NL-14916-ES	B - 14	5JG-14959-00	B - 14	5NL-16384-00	C - 10
3GM-12126-00	B - 5	5XC-12576-90	B - 9	4MX-14392-00	C - 2	5NL-14916-ET	B - 14	5JG-14984-00	C - 2	5NL-17121-00	C - 12
3FV-12153-10	B - 6	5XC-12578-90	B - 9	5XC-14401-90	B - 13	5XC-14922-00	C - 3	4SR-14985-00	C - 2	5NL-17131-10	C - 12
3LN-12153-10	B - 6	5XC-12579-90	B - 9	5XC-14417-90	B - 13	3TJ-14933-40	C - 3	5TA-14987-00	B - 13	5NL-17141-10	C - 12
1HX-12168-00	B - 5	583-13113-00	B - 12	5TA-14428-00	B - 13	5TA-14934-00	C - 3	5TJ-14987-00	C - 3	5NL-17151-00	C - 12
1HX-12168-20	B - 5	5NL-13161-10	B - 12	5NY-14442-00	B - 13	5JG-14940-16	C - 2	5TA-14991-00	C - 3	5NL-17211-10	C - 12
1HX-12168-40	B - 5	5NL-13171-00	B - 12	4XM-14451-00	B - 13	5JG-14940-17	C - 2	4FN-14997-00	B - 14	5NL-17221-00	C - 12
1HX-12168-60	B - 5	5SG-13300-00	B - 10	5XC-14453-90	B - 13	5JG-14940-18	C - 3	5TA-14997-00	C - 3	5NL-17231-10	C - 12
1HX-12168-80	B - 5	5NL-13320-00	B - 10	5NY-14455-10	B - 13	5JG-14940-76	C - 2	5XC-15118-00	C - 8	5NL-17241-11	C - 12
1HX-12168-A0	B - 5	5NL-13341-00	B - 10	5BE-14458-00	B - 13	5TA-14943-28	C - 2	5XC-15150-10	C - 6	5NL-17251-10	C - 12
1HX-12168-F0	B - 5	5BE-13342-00	B - 10	5NY-14459-00	B - 13	4MX-14943-40	B - 15	3Y1-15361-00	C - 8	5NL-17402-00	C - 12
1HX-12168-H1	B - 5	5NL-13411-00	B - 10	5JG-14521-00	B - 15	4MX-14943-41	B - 15	3Y1-15363-00	C - 7	5NL-17411-10	C - 12
1HX-12168-K1	B - 5	5XC-13412-00	B - 10	5JG-14522-00	B - 14	4MX-14943-42	B - 15	5XC-15373-00	C - 7	5NL-17466-00	C - 6

NUMERICAL INDEX

PART NO.	GRID NO.	PART NO.	GRID NO.	PART NO.	GRID NO.	PART NO.	GRID NO.	PART NO.	GRID NO.	PART NO.	GRID NO.
5NL-17471-10	C - 13	5XC-21610-90	D - 4	1C3-22212-50	F - 3	1C3-23142-L0	D - 13	3XJ-24380-00	E - 2	5XE-25853-00	E - 11
5UL-18101-00	C - 15	5XC-21610-D0	D - 4	1C3-22212-60	F - 3	5XE-23144-L0	D - 13	4JT-24500-10	E - 2	5UN-25854-00	E - 13
5XC-18110-00	C - 15	5XE-21635-10	D - 4	5UN-22212-A0	F - 3	1C3-23145-M0	D - 13	4X8-24512-00	E - 2	5XE-25854-00	E - 11
5LP-18122-01	C - 15	5XC-2163G-10	D - 5	5UN-22212-B0	F - 3	5XE-23146-L0	D - 13	3AC-24523-00	E - 2	5UN-2585B-00	E - 13
3XK-18140-00	C - 14	5XC-2163G-20	D - 5	5UN-22212-C0	F - 3	1AE-23147-00	D - 13	3AJ-24534-01	E - 2	5MV-25867-00	E - 11
5BE-18172-00	C - 15	5TA-21642-00	D - 4	5UN-22212-D0	F - 3	1C3-23147-L0	D - 13	5NY-24610-00	E - 2	5NY-25868-00	E - 11
3XJ-18173-10	C - 15	5XC-2164B-00	D - 5	5UN-22212-E0	F - 3	1C3-2314F-M0	D - 13	5XC-2470F-90	E - 4	1C3-25872-50	E - 11
3XJ-18178-00	C - 15	3RV-21668-A0	D - 9	5UN-22212-F0	F - 3	5XE-23153-L0	D - 13	5XC-2470F-A0	E - 4	1C3-25873-00	E - 13
3XJ-18182-00	C - 15	3RV-21668-B0	D - 9	5UN-22212-G0	F - 3	2HH-23158-L0	D - 13	5XC-2470F-D0	E - 4	1C3-25875-50	E - 6
3XJ-18184-00	C - 15	5XC-21710-90	D - 6	3SP-22213-00	D - 10	1C3-2315H-10	D - 15	5XC-24710-90	E - 4	1C3-25876-50	E - 13
4EW-18185-00	C - 15	5XC-21720-90	D - 6	1C3-22214-50	D - 10	1C3-2315J-10	D - 15	5XC-24710-A0	E - 4	1C3-25886-50	E - 13
5NL-18501-00	C - 14	5XC-2172A-90	D - 6	5MV-22224-00	D - 10	1P8-2316A-M0	D - 13	5XC-24710-D0	E - 4	5MV-2589F-00	E - 11
5NL-18502-00	C - 14	5XC-21730-90	D - 6	4JX-22226-00	D - 10	5XC-2316A-R0	D - 13	5NY-25104-00	E - 5	5UN-25914-00	E - 9
5NL-18503-00	C - 14	5XC-21730-D0	D - 6	3SP-22234-00	D - 10	1C3-23170-N0	D - 13	5NY-25111-00	E - 5	5DH-25914-50	E - 9
5NL-18541-00	C - 14	5XC-2173E-01	D - 6	5NY-22241-00	D - 11	5XE-23171-L0	D - 13	5NY-25117-00	E - 5	3SP-25914-51	E - 6
4UN-18542-00	C - 14	5XC-2173F-01	D - 6	5XE-22242-00	D - 11	5DH-23183-00	D - 10	1C3-25181-10	E - 5	5DH-25916-00	E - 6
5DH-18562-00	C - 6	5XC-2173L-01	D - 6	5MV-22253-00	D - 10	509-23184-L0	D - 10	5NY-25183-00	E - 5		E - 9
5XC-21101-90	D - 2	5XC-21740-90	D - 6	1C3-22253-50	D - 10	1C3-23188-L0	D - 13	5NY-25186-00	E - 5	3JD-25917-00	E - 6
5XC-21163-90	D - 3	5XC-21740-D0	D - 6	4AA-22259-40	D - 10	1C3-23188-N0	D - 13	5HD-25304-00	E - 7		E - 9
5XC-21164-90	D - 3	5XC-2174L-01	D - 6	4AA-22259-50	D - 10	1C3-23188-P0	D - 13	5JT-2530S-80	E - 8	5DH-25919-00	E - 6
5PA-2118K-00	D - 4	5XC-21751-90	D - 6	4AA-22259-60	D - 10	1C3-23188-R0	D - 13	5ET-25311-00	E - 7	5DH-25919-50	E - 9
5PA-2118K-10	D - 4	1C3-22110-50	D - 8	4AA-22259-80	D - 10	1C3-23190-L0	D - 13	5ET-25317-00	E - 7	8CR-25924-00	E - 9
5PA-2118K-20	D - 4	5XC-22121-90	D - 9	1C3-22355-00	D - 8	1C3-23340-M0	D - 14	4XM-25364-00	E - 7	3SP-25926-51	E - 6
5XC-21190-90	D - 2	1C3-22122-00	D - 9	4EW-22474-00	D - 10	5XC-23346-L0	D - 15	1C3-25381-10	E - 8	5DH-25933-00	E - 6
1C3-21244-10	D - 2	1C3-22128-00	D - 8	3JE-22475-00	D - 10	3SP-23356-L0	D - 15	1C3-25388-50	E - 8	1UY-25937-51	E - 6
5XC-21274-90	D - 3	1C3-22141-10	D - 8	5NY-22475-00	D - 10	5XE-23389-00	D - 12	1C3-25389-00	E - 8		E - 9
5XC-21288-90	D - 3	1C3-22151-00	D - 8	1C3-22565-00	D - 10	4EW-23416-00	D - 12	4XM-25394-00	E - 7	5XC-26111-90	E - 10
1C3-2135F-00	D - 9	5UN-22176-00	D - 10	5UN-22898-60	E - 9	1C3-23435-50	D - 12	5SF-25394-00	E - 5	5XC-26124-90	E - 10
1C3-2139R-00	D - 9	30X-22178-00	D - 2	1C3-22969-50	D - 8	5XC-23441-90	D - 12	1C3-25447-00	E - 7	5XC-26143-90	E - 10
5XC-21417-00	D - 3	3JD-22178-20	D - 2	5XC-23102-A0	D - 13	5XC-23442-90	D - 12	1C3-25448-00	E - 7	5XC-26143-D0	E - 10
5XC-21418-90	D - 3	5XC-2217A-90	D - 8	5XC-23102-B0	D - 13	1C3-23466-50	D - 15	1C3-25449-00	E - 7	5TJ-26240-C0	E - 10
5XC-21425-90	D - 2	5XC-2217F-90	D - 8	5XC-23103-A0	D - 13	1C3-23467-50	D - 15	1C3-25450-00	E - 8	4GY-26241-00	E - 10
5XC-21426-90	D - 2	4V4-22184-00	D - 2	5XC-23103-B0	D - 14	1C3-23485-60	D - 12	1C3-25451-00	E - 8	4GY-26242-00	E - 10
5XC-21456-90	D - 3	5MV-22184-00	D - 10	5XC-23110-L0	D - 14	5XC-24110-90	E - 2	1C3-25452-00	E - 8	3Y1-26249-00	E - 10
5XC-21471-90	D - 3	1C3-22199-10	D - 8	1C3-23111-L0	D - 13	4EW-2412F-00	E - 2	5CG-25715-00	E - 11	5BE-26281-00	E - 10
5XC-2147E-91	D - 3	5XC-22200-A0	D - 10	276-23114-00	D - 13	5XE-24144-00	E - 2		E - 13	5BE-26282-00	E - 10
5XC-21486-90	D - 3	5XC-22200-B0	D - 10	5XC-23120-L0	D - 13	3FB-2415E-01	D - 4	1C3-25718-50	E - 9	5SF-26287-10	E - 10
1C3-21511-50	D - 4	5XC-22200-C0	D - 10	5XE-23125-L0	D - 13	3ME-2415E-01	D - 5	1C3-2580T-00	E - 6	5XC-26302-90	E - 10
5XC-21511-D0	D - 4	5XC-22200-D0	D - 10	1C3-23136-M0	D - 13	3FB-2415E-11	D - 4	1C3-2580W-50	E - 9	5XC-26334-90	E - 15
4LB-2151H-02	D - 4	5XC-22200-E0	D - 10	1C3-23141-A0	F - 3	3FB-2415E-C0	D - 4	5MV-2581T-00	E - 6	5XC-26335-90	E - 10
3XJ-2151H-A1	D - 4	5XC-22201-A0	D - 10	1C3-23141-B0	F - 3	4SR-2416E-00	D - 4	5UN-25827-60	E - 9	5HD-26337-00	E - 15
3XJ-2151H-B1	D - 5	5XC-22201-B0	D - 10	1C3-23141-C0	F - 3	5XC-24181-90	E - 2	5UN-25828-60	E - 9	5TA-26339-00	E - 15
4XL-2153A-10	D - 15	1C3-22212-00	F - 3	1C3-23141-D0	F - 3	5XC-24182-90	E - 3	5NY-2582W-00	E - 9	1C3-26342-50	E - 10
5XC-2153E-00	D - 4	5UN-22212-00	F - 3	1C3-23141-F0	F - 3	5XC-24183-90	E - 3	5MV-25833-00	E - 11	5HD-26372-00	E - 15
4ES-2153E-01	D - 4	1C3-22212-10	F - 3	1C3-23141-G0	F - 3	3JD-24186-00	E - 2	1C3-2583V-00	E - 13	5NY-26372-00	E - 11
4ES-2153E-20	D - 4	1C3-22212-20	F - 3	1C3-23141-H0	F - 3	5XC-2419A-90	E - 2	5DH-25849-00	E - 6	5XC-27200-91	E - 12
	D - 6	1C3-22212-30	D - 10	1C3-23141-J0	F - 3	5XC-24311-90	E - 2	5MV-25852-01	E - 11	5UN-27217-00	E - 13
5PA-21568-00	D - 5	1C3-22212-40	F - 3	5XC-23141-M0	D - 13	5XC-24339-90	E - 2	5UN-25852-50	E - 13	5XC-27217-90	E - 12

NUMERICAL INDEX

PART NO.	GRID NO.	PART NO.	GRID NO.	PART NO.	GRID NO.	PART NO.	GRID NO.	PART NO.	GRID NO.	PART NO.	GRID NO.
5UN-27218-00	E - 13	90105-06553	C - 6	90179-18001	C - 13	90209-06096	B - 13	90450-17001	B - 11	91402-20012	E - 12
5UN-27222-00	E - 13		C - 13	90179-28003	D - 12	90209-16011	D - 8	90450-22001	B - 9	91402-25015	E - 12
1C3-27311-00	E - 12	90105-08077	E - 6	90185-08008	E - 8	90209-20008	C - 12		B - 10	91808-16023	B - 2
5XE-27411-01	E - 12	90105-08085	C - 5	90185-08009	D - 2	90209-23012	C - 12	90450-25001	B - 9	91812-16001	C - 7
5XE-27421-01	E - 12		D - 2	90185-10060	D - 11	90215-14204	B - 4	90450-32003	B - 9	91A20-05065	B - 9
1C3-27491-50	E - 9	90105-08115	D - 2	90185-14007	D - 9	90215-16289	C - 10	90450-54002	B - 13	92012-05008	D - 3
5XC-28116-00	D - 3	90105-08129	D - 3	90185-16002	D - 8	90215-20003	C - 10	90450-57010	B - 13	92014-05012	E - 15
5TA-2814F-00	D - 3	90105-08659	C - 5	90185-20002	E - 8		C - 12	90450-61002	B - 13	92903-08200	D - 3
5ET-28166-10	D - 3	90105-09002	B - 2	90201-03313	B - 13	90240-08120	E - 12	90464-13073	F - 2	92907-06600	B - 7
5UL-82310-10	F - 2	90105-09004	B - 2	90201-06032	D - 4	90240-10004	E - 12	90464-13077	F - 2	92907-10200	D - 11
5XC-82509-00	F - 2	90105-10072	D - 2	90201-06084	D - 4	90267-32070	B - 13	90464-15195	F - 2	93101-14164	C - 7
5XC-82540-00	F - 2	90105-10079	D - 2	90201-06570	E - 2	90267-48084	C - 5	90465-08029	C - 8	93102-12106	B - 8
5XE-82911-00	E - 15	90109-06034	E - 15	90201-06571	B - 9	90280-03006	B - 4	90465-10013	C - 6	93102-12224	C - 10
5XD-82913-00	E - 15	90109-063F8	C - 14		D - 4	90340-12112	B - 2	90465-13275	E - 3		C - 15
5XD-82946-00	E - 15	90109-065G4	E - 9		D - 7	90340-14128	C - 7		F - 2	93102-18278	C - 9
5MV-83912-00	E - 15	90109-066F0	B - 2	90201-06630	D - 6	90340-32123	C - 7	90467-090A2	B - 9	93102-26468	E - 5
1C3-83922-50	E - 11	90109-067F4	B - 13	90201-08008	C - 5	90387-06009	D - 4	90467-100A1	E - 3	93102-28010	C - 12
5TA-83941-00	E - 15	90109-08078	E - 8	90201-08043	D - 2	90387-06065	B - 9	90467-14015	B - 2	93106-22002	D - 8
5HD-83951-00	E - 15	90110-06228	B - 12	90201-08044	E - 12		E - 2	90468-16001	E - 12	93106-30001	E - 7
1C3-83976-00	E - 15	90110-08051	C - 9	90201-08045	D - 2	90387-06090	D - 4	90480-08608	E - 8	93106-30045	E - 7
5LP-84126-10	E - 15	90111-06059	E - 13	90201-08048	C - 9		E - 2	90480-10289	D - 7	93109-11073	B - 8
5XC-85540-90	F - 2	90116-06541	B - 2		E - 8	90387-06104	D - 12	90480-14433	D - 7	93109-22019	D - 9
5XC-85540-A0	F - 2	90119-06096	D - 4	90201-080H1	C - 10	90387-065G0	D - 7	90480-15528	B - 9	93109-25001	D - 8
1C3-85546-00	F - 2	90119-06128	D - 12	90201-082A6	D - 6	90387-066V6	D - 7	90480-18549	E - 2	93109-28043	D - 8
5TA-85550-00	E - 14	90119-06217	D - 3	90201-08410	C - 3	90387-08041	D - 2	90501-043E0	B - 12	93210-07003	B - 12
5XC-85560-00	E - 14	90119-08086	D - 6	90201-08512	B - 8	90387-0814J	C - 5	90501-052G5	C - 15	93210-07135	B - 12
5XC-85885-00	C - 3	90122-06005	B - 13	90201-096J9	B - 2	90387-086N4	D - 2	90501-06022	C - 14	93210-09008	B - 12
5NY-W0041-00	E - 11	90149-05162	E - 15	90201-10032	E - 12	90387-124F4	C - 15	90501-147A5	C - 9	93210-09754	B - 11
5UN-W0042-50	E - 13	90149-06011	E - 3	90201-10118	E - 11	90387-14009	D - 9	90501-16016	C - 9	93210-10197	B - 10
5MV-W0045-01	E - 6	90149-06126	C - 6		E - 13	90387-16010	D - 8	90501-224J9	C - 10		C - 6
1C3-W0046-50	E - 9	90149-06250	B - 4	90201-104R2	D - 2	90387-18004	D - 8	90506-16007	E - 12	93210-11073	E - 12
3JD-W0047-00	E - 6	90149-06324	E - 14	90201-12028	D - 12	90387-18007	C - 6	90508-12018	C - 11	93210-12759	B - 12
5UN-W0047-50	E - 9	90149-06326	C - 6	90201-12166	B - 10	90387-18012	D - 8	90508-26561	C - 14	93210-14369	C - 7
1UY-W0048-50	E - 6	90149-06327	E - 6	90201-127E1	E - 14	90387-20006	C - 12	90508-28015	E - 12		D - 6
	E - 9	90151-04001	D - 8	90201-14740	D - 9	90387-22001	C - 12	90508-28018	E - 12	93210-15414	B - 9
5UN-W0057-00	E - 6	90151-06032	D - 3	90201-15701	C - 7	90387-225N2	E - 10	90508-291A8	C - 15	93210-16716	C - 7
5UN-W0057-50	E - 9	90152-06010	C - 9	90201-16018	D - 8	90401-08006	B - 12	90508-30743	C - 9	93210-17570	C - 9
5XE-W2587-10	E - 11	90154-05026	F - 2	90201-162H4	C - 9	90401-10015	B - 12	91312-06012	B - 9	93210-19123	C - 7
90101-05033	E - 15	90159-06092	C - 10	90201-167P7	C - 9	90401-10172	E - 11	91312-06016	D - 6	93210-196A4	C - 12
90101-06001	C - 9	90170-14171	B - 4	90201-177G4	C - 9		E - 13	91312-06025	B - 10	93210-21276	F - 2
90101-06041	C - 15	90170-16326	C - 10	90201-20020	E - 8	90430-06014	B - 2		B - 12	93210-32172	C - 7
90101-08006	E - 8	90170-24003	D - 12	90201-20685	C - 9		B - 8	91312-06045	C - 6	93210-47675	B - 12
90105-05014	D - 3	90179-06028	D - 8	90201-21014	D - 8	90430-08119	B - 12	91312-06055	C - 6	93300-60839	D - 2
90105-06027	B - 2	90179-08656	E - 8	90201-24016	D - 12	90430-10188	B - 12	91312-06065	B - 12	93306-00105	B - 8
90105-06064	D - 6	90179-10658	D - 2	90201-286K9	D - 12		C - 6	91312-06070	C - 6	93306-00317	C - 12
90105-06090	D - 4	90179-12657	E - 14	90202-05193	E - 3	90445-09220	E - 2	91312-08020	C - 5	93306-00320	C - 12
90105-06094	C - 8	90179-16011	E - 5	90202-08045	B - 14	90445-09251	E - 2	91316-04012	B - 14	93306-07202	E - 7
90105-06098	C - 7	90179-18001	C - 10	90206-06090	C - 5	90445-14010	B - 11	91317-06030	B - 10	93306-20335	B - 4

NUMERICAL INDEX

PART NO.	GRID NO.	PART NO.	GRID NO.	PART NO.	GRID NO.	PART NO.	GRID NO.	PART NO.	GRID NO.	PART NO.	GRID NO.
93306-20447	C - 12	94330-21084	E - 5	95802-06012	D - 6						
93306-20648	B - 4	94416-21034	E - 5	95817-10030	D - 2						
93306-27208	C - 12	94418-19008	E - 7	95817-10060	D - 2						
93306-27212	E - 7	94591-53114	B - 7	95824-06016	D - 6						
93306-90409	E - 5	94681-68001	E - 8	97027-06016	B - 7						
93306-90501	C - 14	94701-00410	B - 2	97707-60016	D - 4						
93310-63238	B - 4	94701-00411	B - 2	98502-03008	E - 2						
93311-32261	B - 4	94703-00410	B - 2	98502-06025	C - 6						
93315-32166	D - 8	94703-00411	B - 2	98504-05010	E - 13						
93315-32269	D - 8	95022-06010	B - 2	98507-05020	E - 10						
93317-11287	C - 10		B - 9	98706-04012	E - 11						
93317-22262	D - 8		C - 11	98707-06025	E - 2						
93332-00068	D - 12	95022-06012	B - 8	98980-06008	C - 5						
93332-00081	D - 14		E - 9	99001-08600	B - 10						
93340-21008	C - 10	95022-06016	B - 10	99009-12400	B - 10						
93342-22217	D - 8	95022-06020	C - 15	99009-16400	C - 9						
93410-20038	C - 9	95022-06025	B - 7	99009-17400	C - 9						
93410-22039	C - 12		B - 8	99009-22500	C - 7						
93410-26067	C - 12		B - 10	99009-45500	E - 7						
93420-16086	B - 4		C - 7	99530-08012	B - 10						
93440-07149	B - 2		D - 7	99530-08016	C - 7						
93440-07182	B - 8	95022-06035	B - 3	99530-10114	B - 10						
	C - 10		C - 7		C - 6						
93440-10153	B - 2	95022-06065	B - 8	99530-10116	C - 6						
	B - 10	95022-08012	D - 6	9Y581-92111	E - 8						
93440-41178	B - 7	95022-08040	D - 2								
93503-08007	B - 12	95022-10016	C - 6								
93507-32009	C - 9	95024-06010	D - 8								
93511-32027	C - 10		E - 6								
93603-16219	B - 10	95024-06016	E - 9								
93604-10011	B - 8	95024-06020	D - 12								
93608-33002	C - 15	95024-06030	E - 2								
93612-16254	B - 3		E - 9								
	C - 6	95024-06050	D - 8								
9383B-13218	C - 12	95024-08035	D - 12								
94108-21012	E - 5	95024-08045	D - 2								
94108-21015	E - 5	95027-06012	B - 12								
94108-2112Y	E - 5	95027-06016	E - 2								
94110-19009	E - 7	95027-06020	D - 4								
94110-19012	E - 7	95027-06030	B - 9								
94110-1913B	E - 7	95602-12200	D - 12								
94209-21229	E - 5	95607-05100	E - 15								
94210-19222	E - 7	95607-10200	D - 11								
94210-19224	E - 7	95612-08620	B - 2								
94227-21101	E - 5	95701-06500	E - 11								
94309-21161	E - 5	95702-06500	B - 3								
94316-19156	E - 7		D - 15								
94321-19135	E - 7	95702-08500	B - 2								