

YAMAHA



**PARTS
CATALOGUE**

YZ80G (4ES4) U.S.A., CANADA, NEWZEALAND, S.AFRICA

YZ80LWG (4LC2) NEWZEALAND, SWEDEN

J54ES-100E1

YAMAHA
GENUINE
Parts & Accessories

A2



FOREWORD

This Parts Catalogue is related to the parts for the model(s) in the below frame. When you are ordering replacement parts, please refer to this Parts Catalogue and quote both part numbers and part names correctly.

YZ80G (4ES4), YZ80LWG (4LC2)

- Modifications or additions which have been made after issue of the Parts Catalogue will be announced in the Yamaha Parts News.
It is advisable that you make necessary corrections to the Parts Catalogue according to the Yamaha Parts News.

- Abbreviations
The following abbreviations are used in this Parts Catalogue.

"UR" Use specified parts number.
 "UN" Use as many as needed.
 "AP" Alternate Parts
 "LM" Local Made (Parts need to be ordered locally)
 "F#" Frame No. (Applicable machine No.)

- Parts, which are to be supplied in an assembly, are listed with a dot (.) in front of the part name as shown below.

EXAMPLE
 CARBURETOR ASSY
 . JET, PILOT
 . NOZZLE, MAIN

- Number of component for assembly
The numeral appearing to the right of each component part indicates the quantity of parts for each assembly unit.

EXAMPLE

PART NO.	DESCRIPTION	Q'TY	REMARKS
2F5-83310-60	FRONT FLASHER LIGHT ASSY	2	
115-83311-60	. BULB (6V-18W)	1	

- Applicable colors of graphics are represented in the "REMARKS" as shown below.

PART NO.	DESCRIPTION	Q'TY	REMARKS
2N4-24110-00-XS	FUEL TANK COMP.	1	MAXIM RED
3J1-24240-10	. GRAPHIC, FUEL TANK	1	for MXR

- Applicable Serial No. and Color Code

4ES4	① Frame Serial No. 4ES-025101 ~
	② Engine Serial No. 4ES-025101 ~
4LC2	① Frame Serial No. 4LC-001101 ~
	② Engine Serial No. 4LC-001101 ~

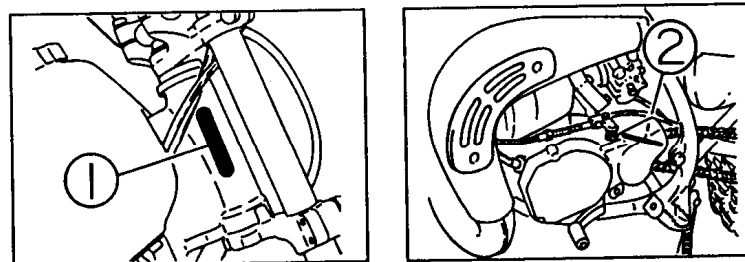

Color Code	Color Name	Abbreviation
0206	PURPLISH WHITE SOLID 1	PWS1

- Note that the illustrations are for reference in finding parts numbers, not to be used for assembling. When assembling, please use the applicable service manual.
- The asterisk (*) before a reference number indicates modification items after the first edition.

CONTENTS

ENGINE

Cylinder	B2
Crankshaft. Piston	B3
Water Pump	B4
Radiator. Hose	B5
Intake	B6
Carburetor	B7~B8
Exhaust	B9
Crankcase	B10
Crankcase Cover 1	B11
Starter	B12
Clutch	B13
Transmission	B14~B15
Shift Cam. Fork	C2
Shift Shaft	C3

CHASSIS

Frame	C4
Fender	C5
Side Cover	C6
Rear Arm	C7~C8
Rear Suspension	C9
Steering	C10
Front Fork	C11~C12
Fuel Tank	C13
Seat	C14
Front Wheel	C15
Front Brake Caliper	D2
Rear Wheel	D3~D4
Rear Brake Caliper	D5

Steering Handle. Cable	D6
Front Master Cylinder	D7
Stand. Footrest	D8
Rear Master Cylinder	D9
Generator	D10
Handle Switch. Lever	D11
Electrical 1	D12

ALTERNATE PARTS

Alternate (Chassis)	D13
---------------------------	-----

REPAIR KIT

Repair Kit	D14
------------------	-----

INDEX

Numerical Index	M1~M3
-----------------------	-------

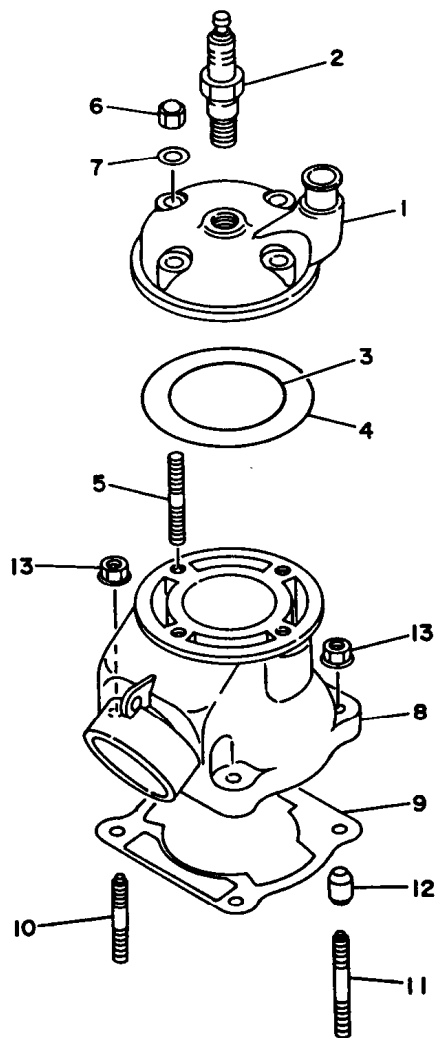

FIG. 1 CYLINDER

REF. NO.	PART NO.	DESCRIPTION	Q'TY	REMARKS
1	4ES-11111-00	HEAD, CYLINDER 1	1	
2	94702-00367	PLUG, SPARK (NGK B10EG)	1	UR
	94702-00368	PLUG, SPARK (NGK BR10EG)	1	UR FOR CANADA,S.AFRICA
3	93210-56459	O-RING	1	
4	93210-84724	O-RING	1	
5	90116-08394	BOLT, STUD	4	
6	90176-08026	NUT, CROWN	4	
7	90201-08087	WASHER, PLATE	4	
8	4ES-11311-00	CYLINDER 1	1	
9	4ES-11351-00	GASKET, CYLINDER	1	
10	90116-08318	BOLT, STUD	2	
11	90116-08388	BOLT, STUD	2	
12	99510-10114	PIN, DOWEL	2	
13	90179-08491	NUT	4	



4ES1100-3010

B2

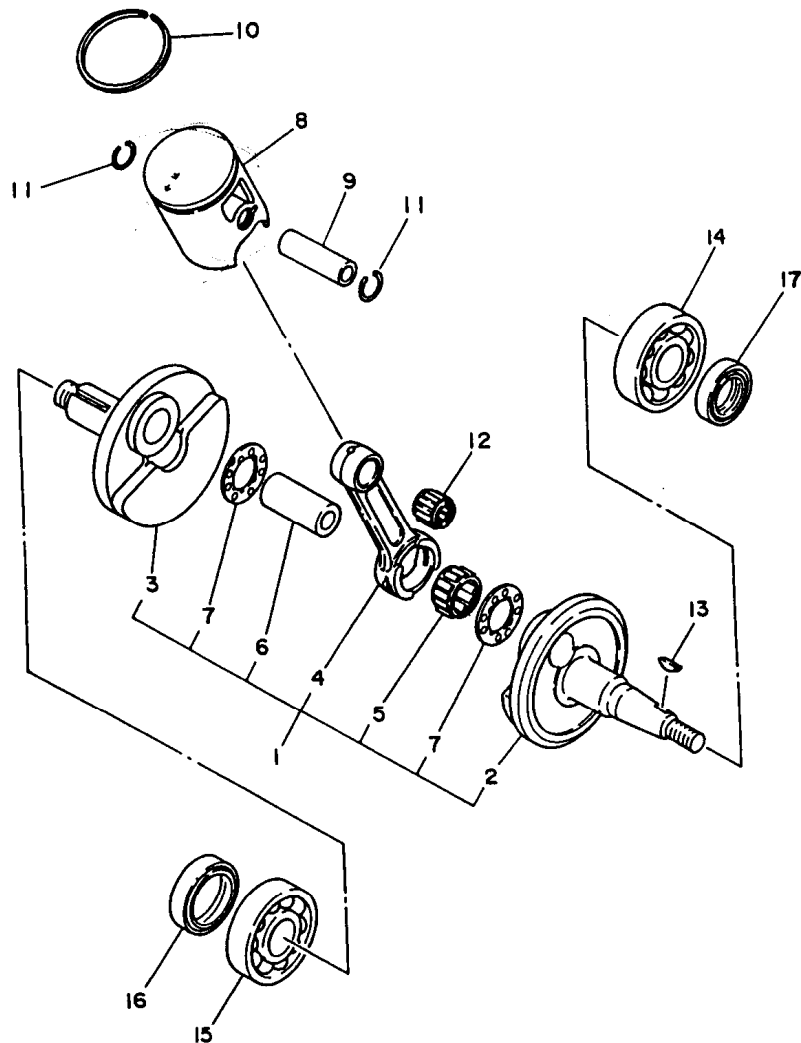

FIG. 2 CRANKSHAFT. PISTON

REF. NO.	PART NO.	DESCRIPTION	Q'TY	REMARKS
1	4ES-11400-02	CRANKSHAFT ASSY	1	
2	4ES-11412-00	.CRANK 1	1	
3	4ES-11422-00	.CRANK 2	1	
4	4ES-11651-01	.ROD, CONNECTING	1	
5	93310-320T3	.BEARING, CYLINDRICAL	1	
6	2RA-11681-00	.PIN, CRANK 1	1	
7	90209-20159	.WASHER	2	
8	4ES-11631-01-A0	PISTON (STD)	1	UR RED
	4ES-11631-01-B0	PISTON (STD)	1	UR ORANGE
	4ES-11631-01-C0	PISTON (STD)	1	UR GREEN
	4ES-11631-01-D0	PISTON (STD)	1	UR PURPLE
9	4ES-11633-00	PIN, PISTON	1	
10	43K-11611-00	RING, PISTON	1	
11	93450-16115	CIRCLIP	2	
12	93310-214F8	BEARING, CYLINDRICAL	1	KOYO
13	90280-03017	KEY, WOODRUFF	1	
14	93306-20468	BEARING	1	
15	93306-30421	BEARING (B6304C3)	1	
16	93103-28126	OIL SEAL	1	
17	93102-20447	OIL SEAL	1	



4ES1100-3020

B3

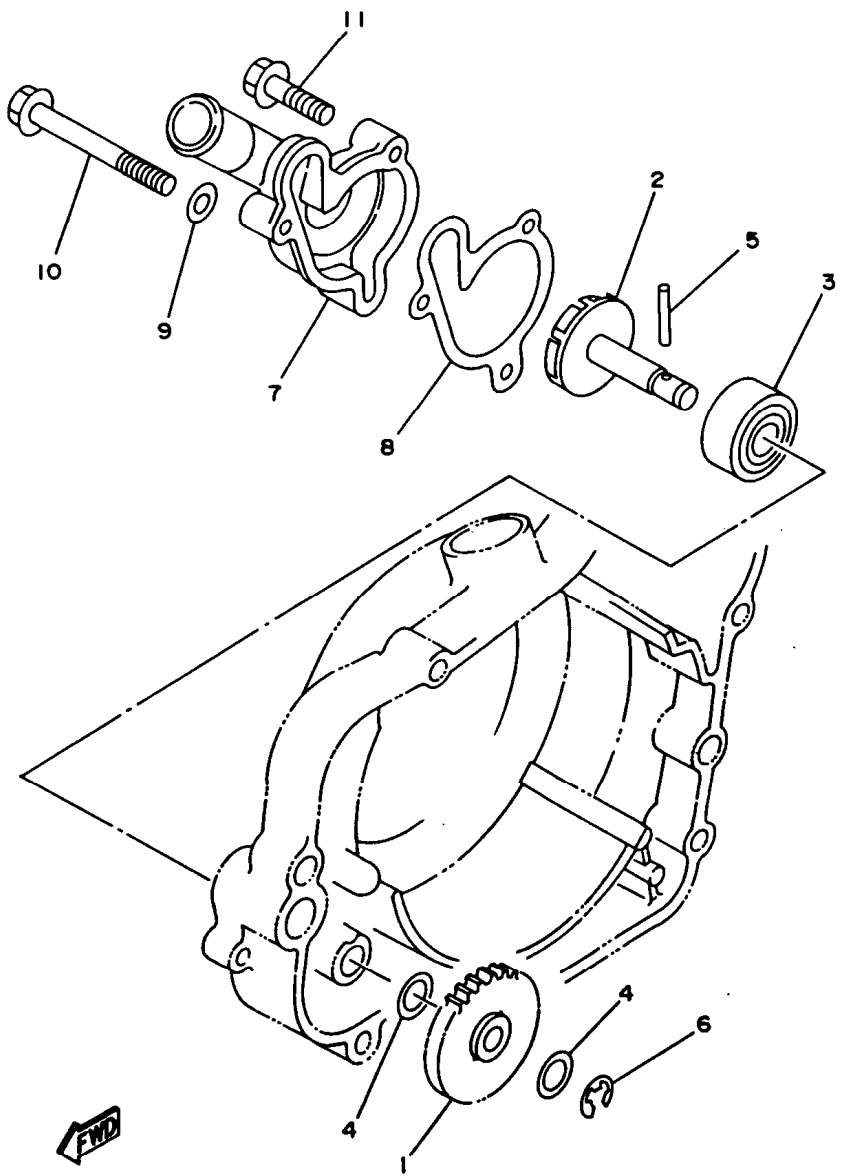
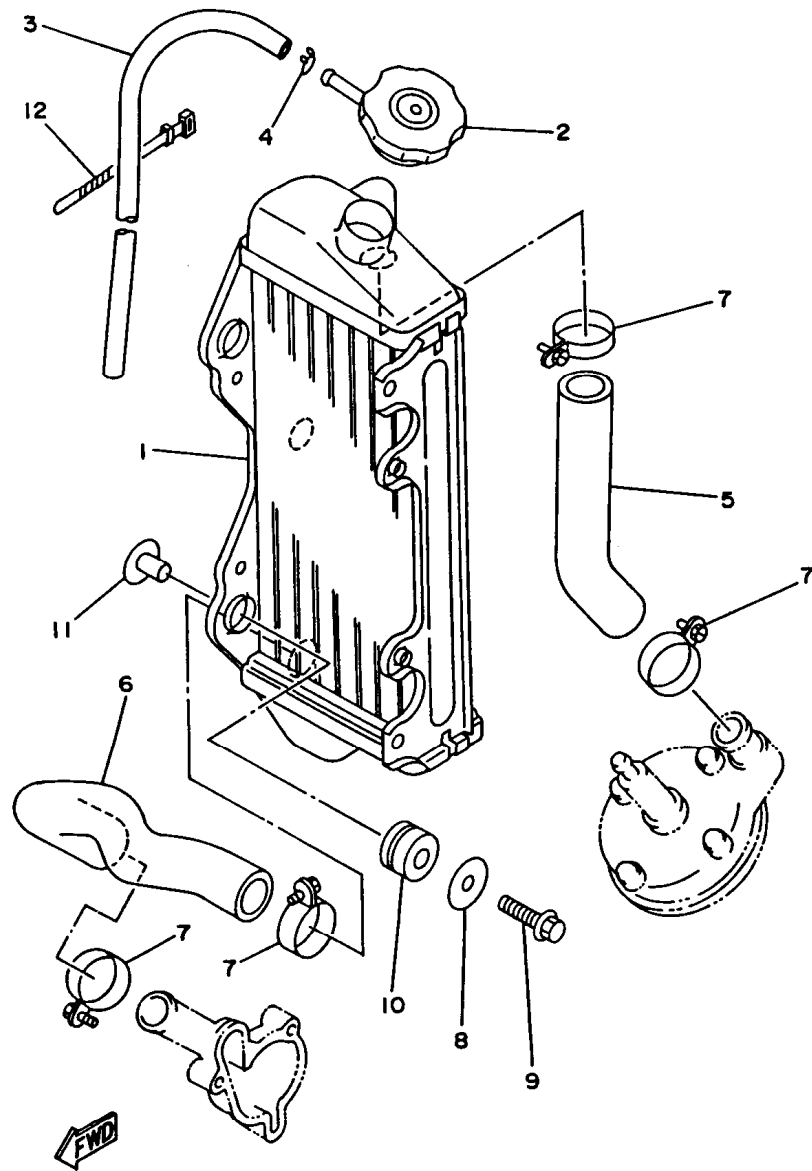

FIG. 3 WATER PUMP

REF. NO.	PART NO.	DESCRIPTION	Q'TY	REMARKS
1	4ES-12459-00	GEAR, IMPELLER SHAFT	1	
2	36F-12450-00	IMPELLER SHAFT ASSY	1	
3	93103-10168	OIL SEAL	1	
4	90201-08512	WASHER, PLATE	2	
5	93603-22028	PIN, DOWEL	1	
6	99080-07600	CIRCLIP	1	
7	4BA-12422-00	COVER, HOUSING	1	
8	4BA-12428-00	GASKET, HOUSING COVER 2	1	
9	90430-06166	GASKET	1	
10	95827-06060	BOLT, FLANGE	1	
11	95027-06025	BOLT	2	

 4ES1100-3030

B4



4ES1100-3040

FIG. 4 RADIATOR. HOSE

REF. NO.	PART NO.	DESCRIPTION	Q'TY	REMARKS
1	4ES-12461-00	RADIATOR ASSY	1	
2	22W-12462-00	CAP, RADIATOR	1	
3	22W-12463-00	PIPE, BREATHER	1	
4	90467-08004	CLIP	1	
5	4ES-12481-00	PIPE 1	1	
6	4ES-12482-00	PIPE 2	1	
7	90450-28014	HOSE CLAMP ASSY	4	
8	90201-063J2	WASHER, PLATE	3	
9	95027-06030	BOLT	3	
10	90480-15528	GROMMET	3	
11	90387-0700G	COLLAR	3	
12	437-83936-01	BAND, SWITCH CORD	1	

B5

FIG. 5 INTAKE

REF. NO.	PART NO.	DESCRIPTION	Q'TY	REMARKS
1	4ES-13610-00	REED VALVE ASSY	1	
2	4ES-13613-00	.REED, VALVE	2	
3	4ES-13616-00	.STOPPER, REED VALVE	2	
4	98507-03008	.SCREW, PAN HEAD	4	
5	92907-03100	.WASHER	4	
6	4ES-13565-00	JOINT, CARBURETOR	1	
7	95027-06020	BOLT, FLANGE	4	
8	90460-43053	CLAMP, HOSE	1	
9	90460-51059	CLAMP, HOSE	1	
10	4ES-14453-00	JOINT, AIR CLEANER 1	1	
11	4ES-14459-00	HOLDER, GUIDE	1	
12	4ES-14462-00	.SEAL	1	
13	97707-50014	SCREW, TAPPING	5	
14	90450-99064	HOSE CLAMP ASSY	1	
15	4ES-14411-01	CASE, AIR CLEANER 1	1	
16	4ES-14417-00	.COVER 1	1	
17	90267-40077	.RIVET, BLIND	2	
18	90201-047A2	.WASHER, PLATE	2	
19	92907-04600	.WASHER	2	
20	4ES-14451-00	ELEMENT, AIR CLEANER	1	
21	4ES-14458-00	GUIDE	1	
22	90209-06096	WASHER	1	
23	90122-06034	BOLT, WING	1	
24	92907-06100	WASHER	1	

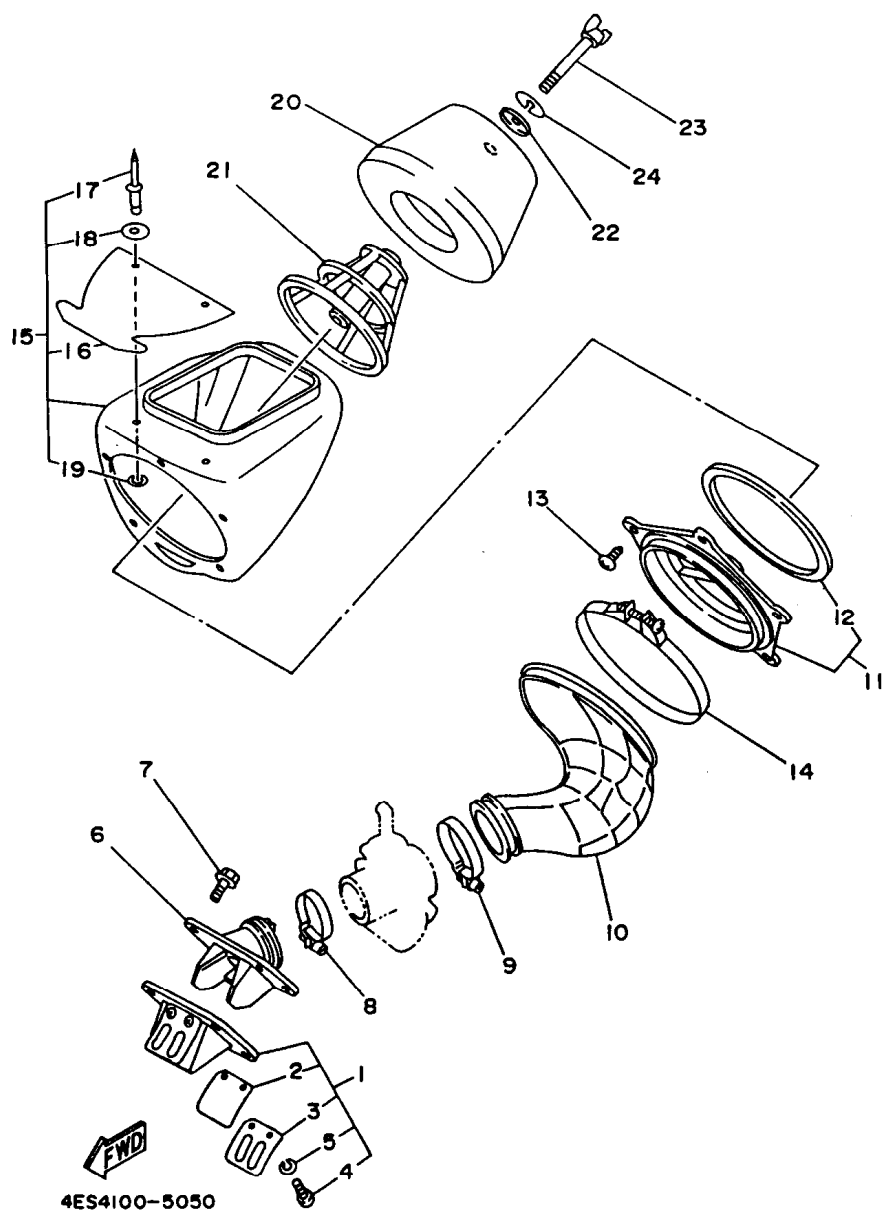

4ES4100-5050

B6

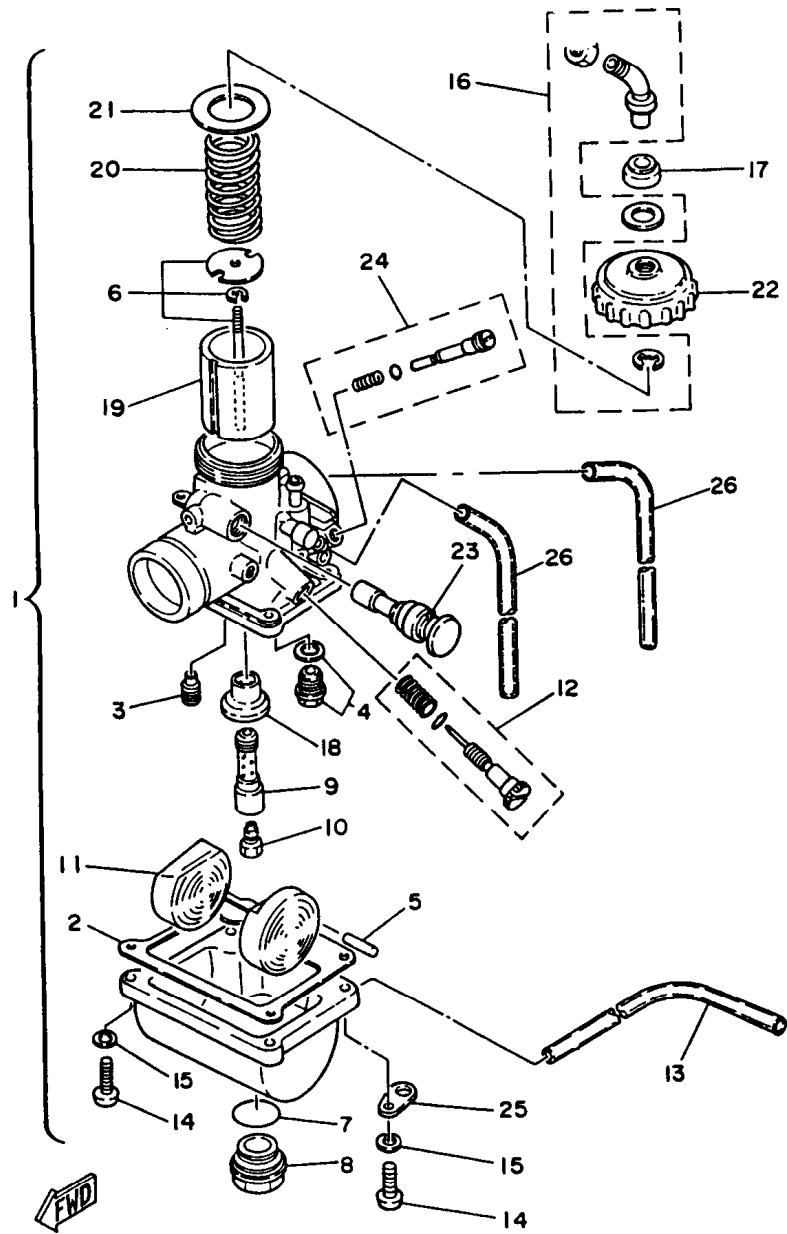

4ES1100-3060

FIG. 6 CARBURETOR

REF. NO.	PART NO.	DESCRIPTION	Q'TY	REMARKS
1	4ES-14101-01	CARBURETOR ASSY 1	1	
2	304-14184-00	.GASKET, FLOAT CHAMBER	1	
3	260-14142-35	.JET, PILOT (# 35)	1	STD
	260-14142-30	.JET, PILOT (# 30)	1	AP
	260-14142-40	.JET, PILOT (# 40)	1	AP
4	23L-14107-25	.NEEDLE VALVE SET	1	
5	127-14186-00	.PIN, FLOAT	1	
6	58T-1490J-00	.NEEDLE SET	1	
7	93210-18288	.O-RING	1	
8	3R1-14115-00	.PLUG, SCREW	1	
9	3R1-14141-52	.NOZZLE, MAIN	1	STD
	3R1-14141-50	.NOZZLE, MAIN	1	AP
	3R1-14141-54	.NOZZLE, MAIN	1	AP
10	137-14143-58-A1	.JET, MAIN (#290)	1	STD
	137-14143-56-A0	.JET, MAIN (#280)	1	AP
	137-14143-60-A0	.JET, MAIN (#300)	1	AP
11	314-14185-00	.FLOAT	1	
12	31J-14103-00	.THROTTLE SCREW SET	1	
13	278-14197-00	.PIPE	1	
14	98511-04016	.SCREW, PAN HEAD	4	
15	92902-04100	.WASHER, SPRING	4	
16	22W-14106-00	.CABLE ADJUST SCREW SET	1	
17	3X3-14169-00	.CAP	1	
18	39K-14153-00	.WASHER, MAIN JET	1	
19	2X6-14112-30	.VALVE, THROTTLE 1	1	STD
	2X6-14112-25	.VALVE, THROTTLE 1	1	AP
	2X6-14112-35	.VALVE, THROTTLE 1	1	AP
20	248-14131-00	.SPRING, THROTTLE VALVE	1	

B7

FIG. 6 CARBURETOR

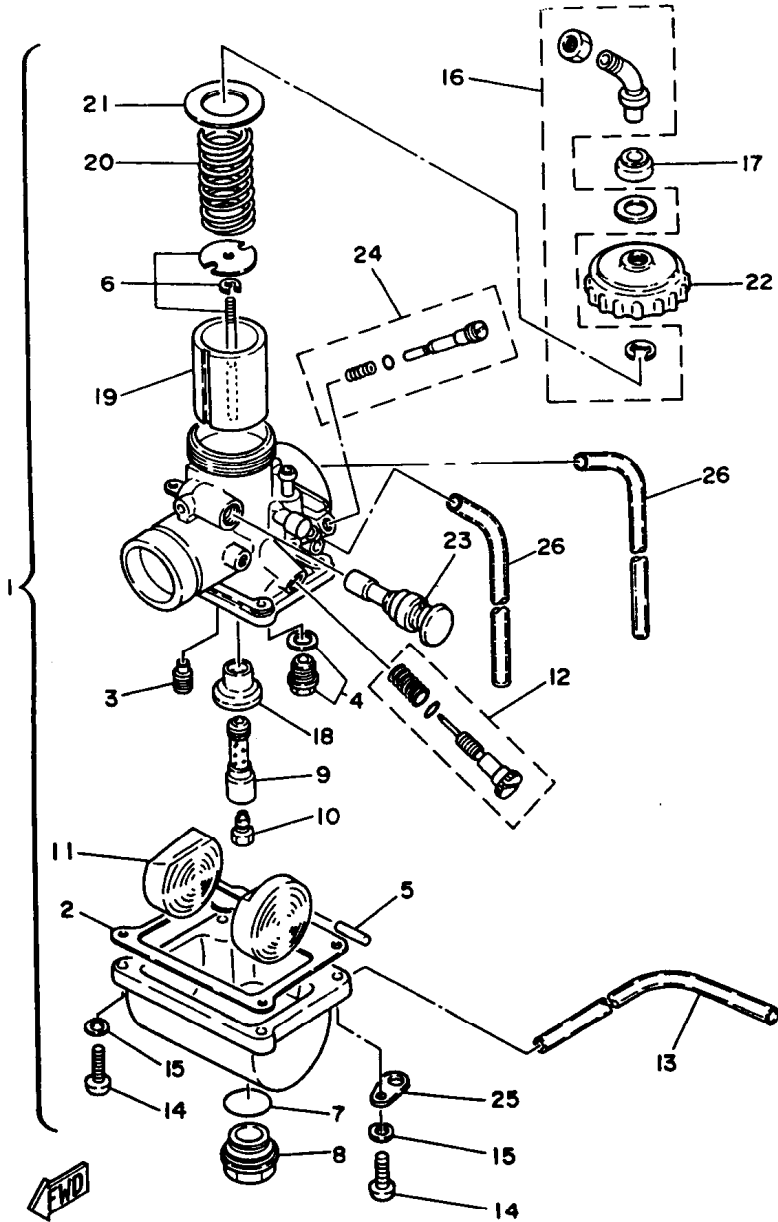

REF. NO.	PART NO.	DESCRIPTION	Q'TY	REMARKS
21	2A6-14126-00	.GASKET	1	
22	2A6-14158-00	.TOP, MIXING CHAMBER	1	
23	3SB-14171-00	.PLUNGER, STARTER	1	
24	10W-14104-00	.AIR SCREW SET	1	
25	132-14146-00	.PLATE	1	
26	55X-14196-00	.PIPE	2	

4ES1100-3060

B8

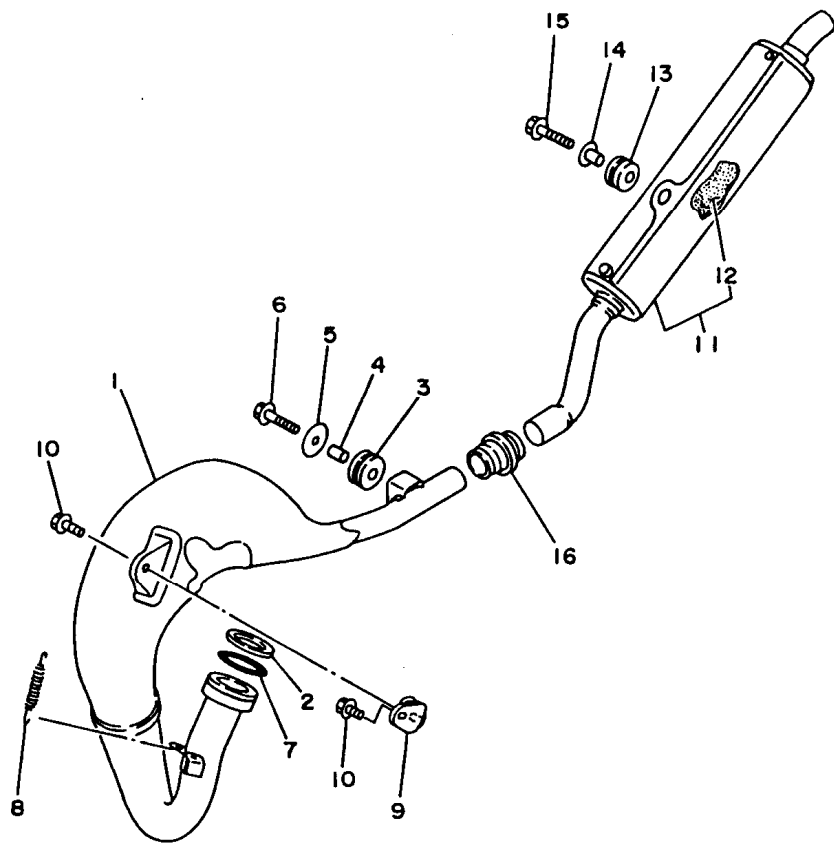

FIG. 7 EXHAUST

REF. NO.	PART NO.	DESCRIPTION	Q'TY	REMARKS
1	4ES-14610-00	EXHAUST PIPE ASSY 1	1	
2	90201-33299	WASHER, PLATE	1	
3	90480-18411	GROMMET	1	
4	90387-105L0	COLLAR	1	
5	90201-060A3	WASHER, PLATE	1	
6	95027-06025	BOLT	1	
7	93210-371A9	O-RING	1	
8	90507-20030	SPRING, TENSION	1	
9	565-14771-00	STAY, MUFFLER 1	1	
10	95027-06012	BOLT	2	
11	4ES-14753-00	SILENCER, EXHAUST	1	
12	4ES-1469A-00	.FIBER	1	
13	90480-16561	GROMMET	1	
14	90387-063G3	COLLAR	1	
15	95027-06025	BOLT	1	
16	17W-14615-00	JOINT, EXHAUST 1	1	



4ES3100-4070

B9

FIG. 8 CRANKCASE

REF. NO.	PART NO.	DESCRIPTION	Q'TY	REMARKS
1	4ES-15111-00	CRANKCASE 1	1	
2	4ES-15121-01	CRANKCASE 2	1	
3	99530-10014	PIN, DOWEL	2	
4	98507-06040	SCREW, PAN HEAD	3	
5	98507-06050	SCREW, PAN HEAD	5	
6	98507-06060	SCREW, PAN HEAD	3	
7	583-15371-00	BREATHER	1	
8	90446-07349	HOSE	1	

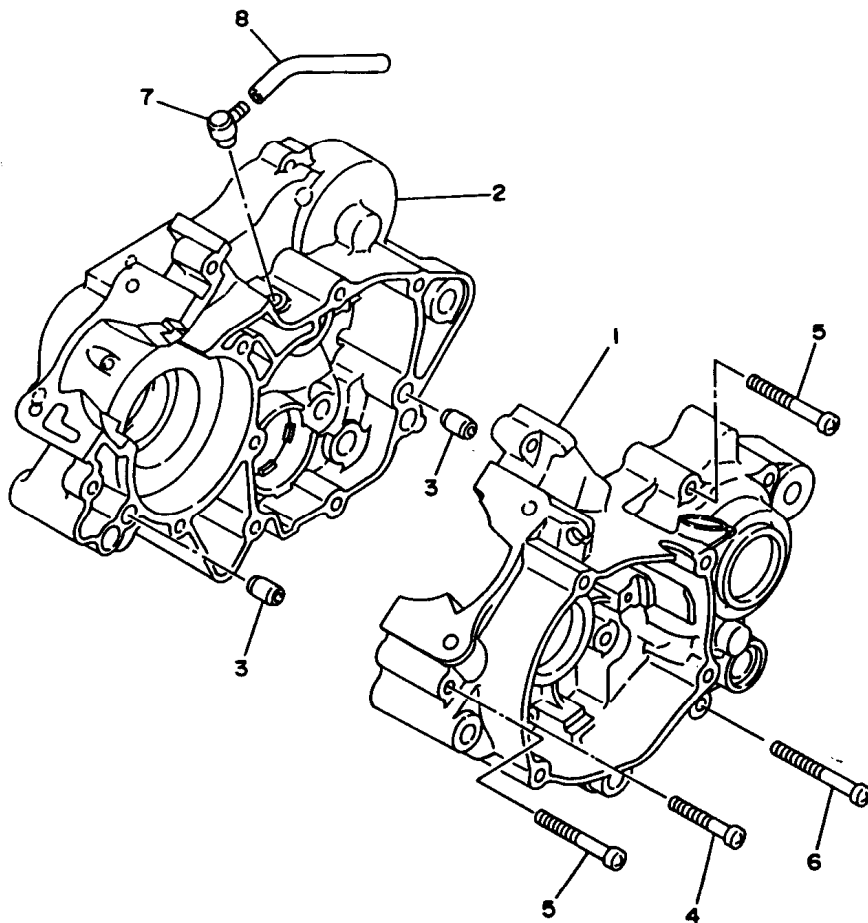

4ES1100-3080

B10

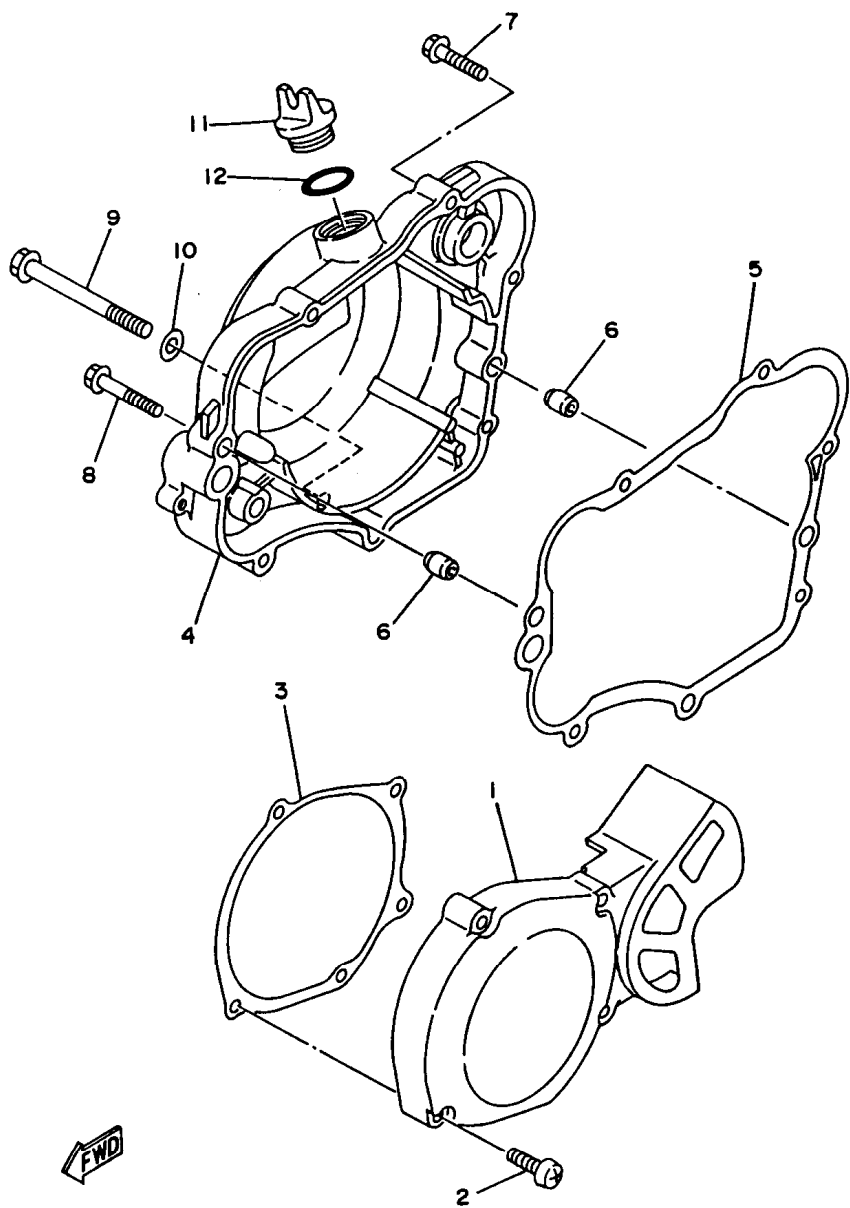

FIG. 9 CRANKCASE COVER 1

REF. NO.	PART NO.	DESCRIPTION	Q'TY	REMARKS
1	4ES-15411-00	COVER, CRANKCASE 1	1	
2	98507-06030	SCREW, PAN HEAD	4	
3	4ES-15451-00	GASKET, CRANKCASE COVER 1	1	
4	4ES-15421-01	COVER, CRANKCASE 2	1	
5	4ES-15461-00	GASKET, CRANKCASE COVER 2	1	
6	99530-10014	PIN, DOWEL	2	
7	95027-06030	BOLT, FLANGE	4	
8	95027-06040	BOLT, FLANGE	1	
9	95027-08080	BOLT, FLANGE	1	
10	90201-08087	WASHER, PLATE	1	
11	1RG-15363-00	PLUG, OIL	1	
12	93210-19123	O-RING	1	

4ES1100-3090

B11

FIG. 10 STARTER

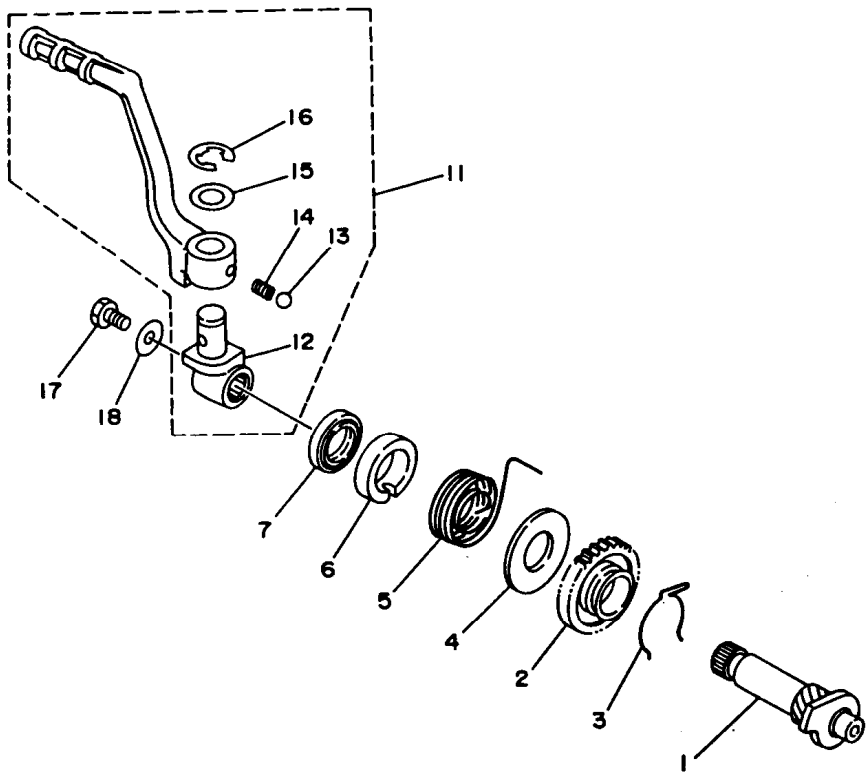

REF. NO.	PART NO.	DESCRIPTION	Q'TY	REMARKS
1	4ES-15660-00	KICK AXLE ASSY	1	
2	4ES-15641-00	GEAR, KICK	1	
3	90468-23194	CLIP	1	
4	90201-176L4	WASHER, PLATE	1	
5	90508-26750	SPRING, TORSION	1	
6	4ES-15664-00	GUIDE, SPRING	1	
7	93102-17263	OIL SEAL	1	
8	4ES-15651-00	GEAR, KICK IDLE	1	
9	90201-124F8	WASHER, PLATE	2	
10	99009-12400	CIRCLIP	1	
11	4ES-15620-00	KICK CRANK ASSY	1	
12	4ES-15621-00	.BOSS, KICK CRANK	1	
13	93507-32031	.BALL	1	
14	90501-12081	.SPRING, COMPRESSION	1	
15	90201-12631	.WASHER, PLATE	1	
16	93430-08007	.CIRCLIP	1	
17	95027-06012	BOLT	1	
18	90201-065F3	WASHER, PLATE	1	

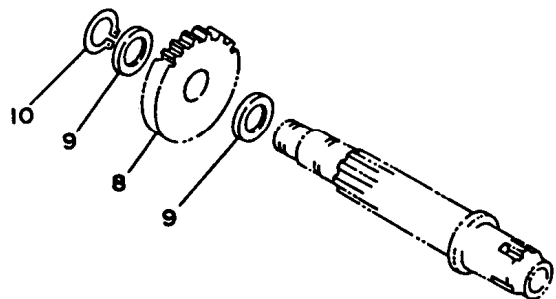

4ES1100-3100

B12

FIG. 11 CLUTCH

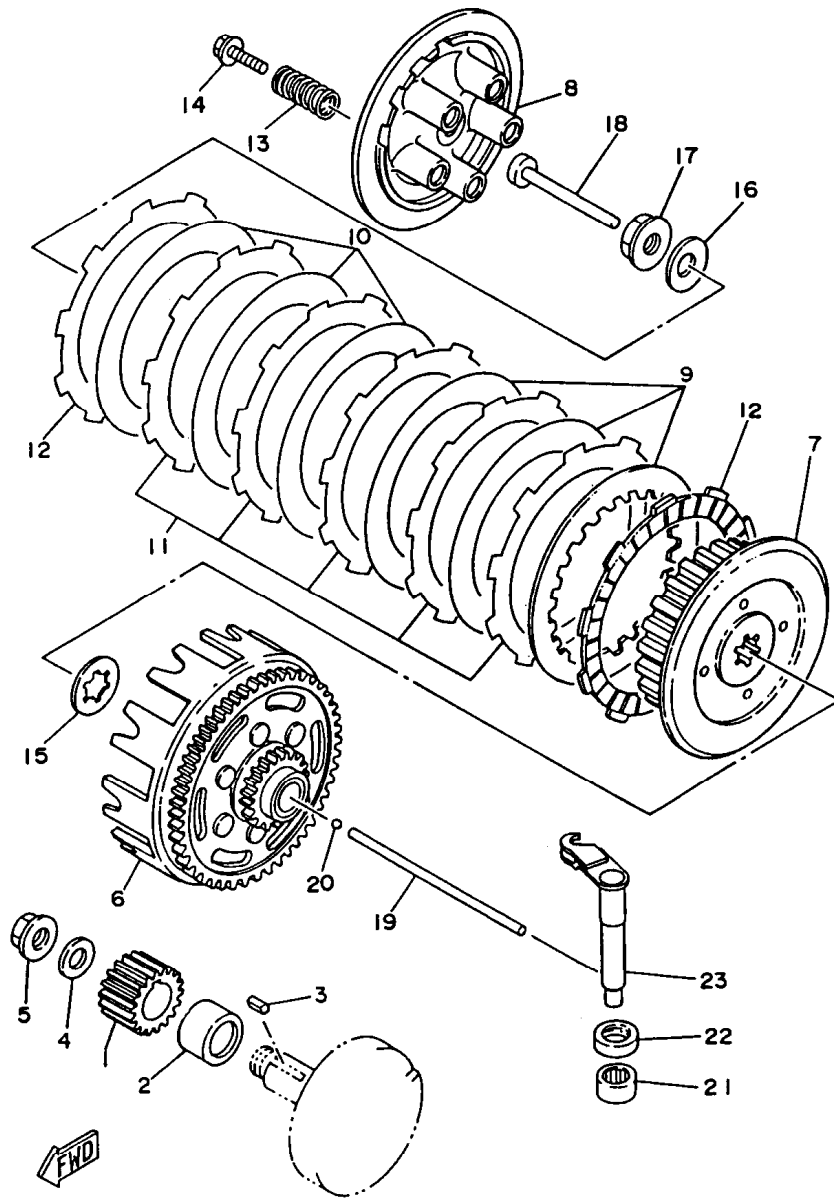

4ES4100-5110

REF. NO.	PART NO.	DESCRIPTION	Q'TY	REMARKS
1	4ES-16111-00	GEAR, PRIMARY DRIVE	1	
2	90387-20488	COLLAR	1	
3	90282-05001	KEY, STRAIGHT	1	
4	90208-12015	WASHER, CONICAL SPRING	1	
5	90179-12244	NUT	1	
6	4ES-16150-10	PRIMARY DRIVEN GEAR COMP.	1	
7	37F-16371-00	BOSS, CLUTCH	1	
8	2TK-16351-00	PLATE, PRESSURE 1	1	
9	257-16324-00	PLATE, CLUTCH 1	3	
10	131-16324-00	PLATE, CLUTCH 1	3	
11	4ES-16321-00	PLATE, FRICTION	5	
12	21V-16321-00	PLATE, FRICTION	2	
13	90501-20735	SPRING, COMPRESSION	5	
14	90119-05001	BOLT, WITH WASHER	5	
15	4V0-16154-00	PLATE, THRUST 1	1	
16	90208-12015	WASHER, CONICAL SPRING	1	
17	90179-12244	NUT	1	
18	4ES-16356-00	ROD, PUSH 1	1	
19	2RA-16357-00	ROD, PUSH 2	1	
20	93503-16010	BALL	1	
21	93315-11206	BEARING, CYLINDRICAL	1	
22	93102-12224	OIL SEAL	1	
23	4ES-16381-00	PUSH LEVER COMP.	1	

FIG. 12 TRANSMISSION

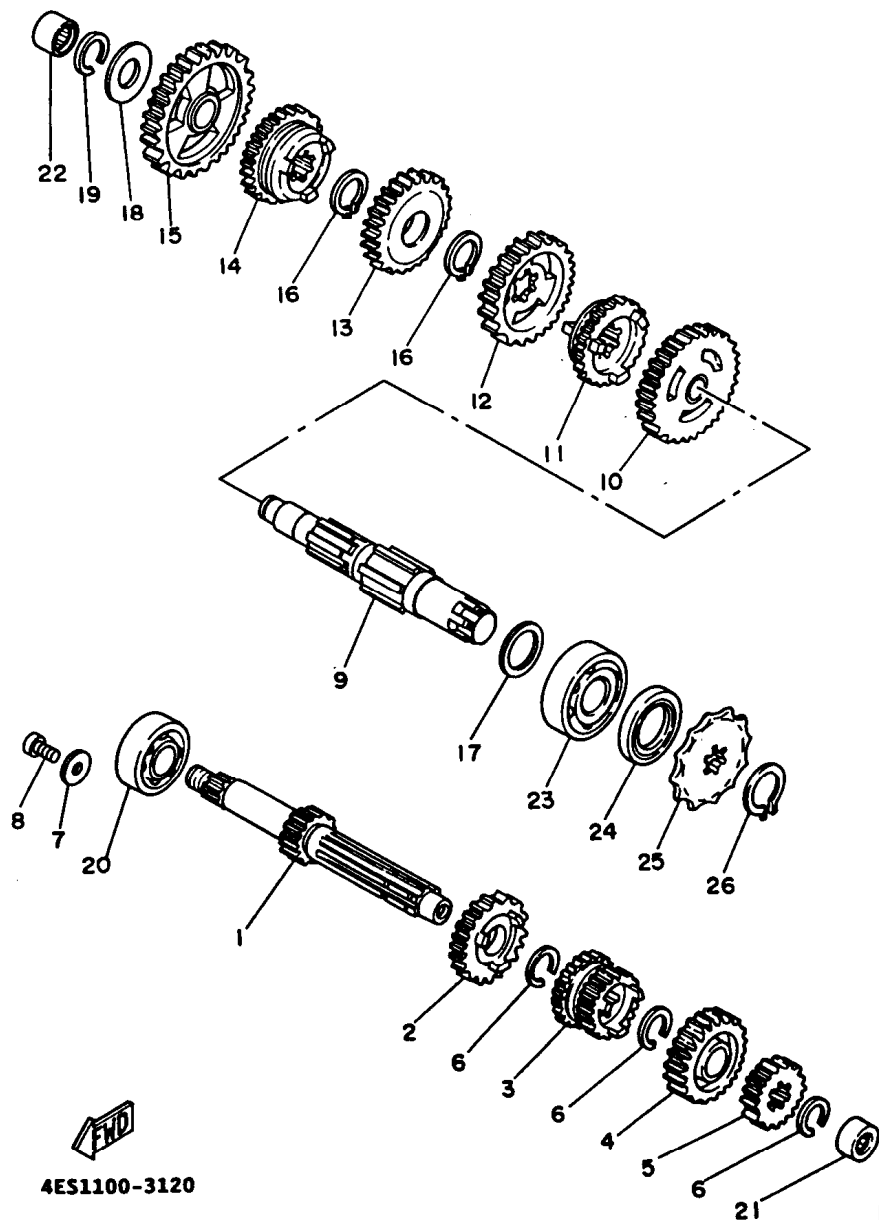

REF. NO.	PART NO.	DESCRIPTION	Q'TY	REMARKS
1	4ES-17411-00	AXLE, MAIN	1	
2	4ES-17151-00	GEAR, 5TH PINION	1	
3	4ES-17131-00	GEAR, 3RD PINION	1	
4	4ES-17161-00	GEAR, 6TH PINION	1	
5	4ES-17121-00	GEAR, 2ND PINION	1	
6	93440-17064	CIRCLIP	3	
7	90201-065F3	WASHER, PLATE	2	
8	90157-06071	SCREW, PAN HEAD	2	
9	4ES-17421-00	AXLE, DRIVE	1	
10	4ES-17221-00	GEAR, 2ND WHEEL	1	
11	4ES-17261-00	GEAR, 6TH WHEEL	1	
12	4ES-17231-00	GEAR, 3RD WHEEL	1	
13	4ES-17241-00	GEAR, 4TH WHEEL	1	
14	4ES-17251-00	GEAR, 5TH WHEEL	1	
15	4ES-17211-01	GEAR, 1ST WHEEL	1	
16	93410-20038	CIRCLIP	2	
17	90201-203E7	WASHER, PLATE	1	
18	164-17427-00-06	SHIM 1 (0.6T)	1	
19	93440-15012	CIRCLIP	1	
20	93306-20333	BEARING	1	
21	93317-11245	BEARING, CYLINDRICAL	1	
22	93315-31502	BEARING, CYLINDRICAL	1	
23	93306-20421	BEARING (B6204)	1	
24	93102-20143	OIL SEAL	1	
25	93822-14037	SPROCKET, DRIVE 14T (1741746140)	1	STD
	93822-12012	SPROCKET, DRIVE 12T (1741746120)	1	AP
	93822-13024	SPROCKET, DRIVE 13T (1741746130)	1	STD YZ80LW MODEL
	93822-15065	SPROCKET, DRIVE 15T (1741746150)	1	AP

B14

FIG. 12 TRANSMISSION

REF. NO.	PART NO.	DESCRIPTION	Q'TY	REMARKS
26	99009-18400	CIRCLIP	1	

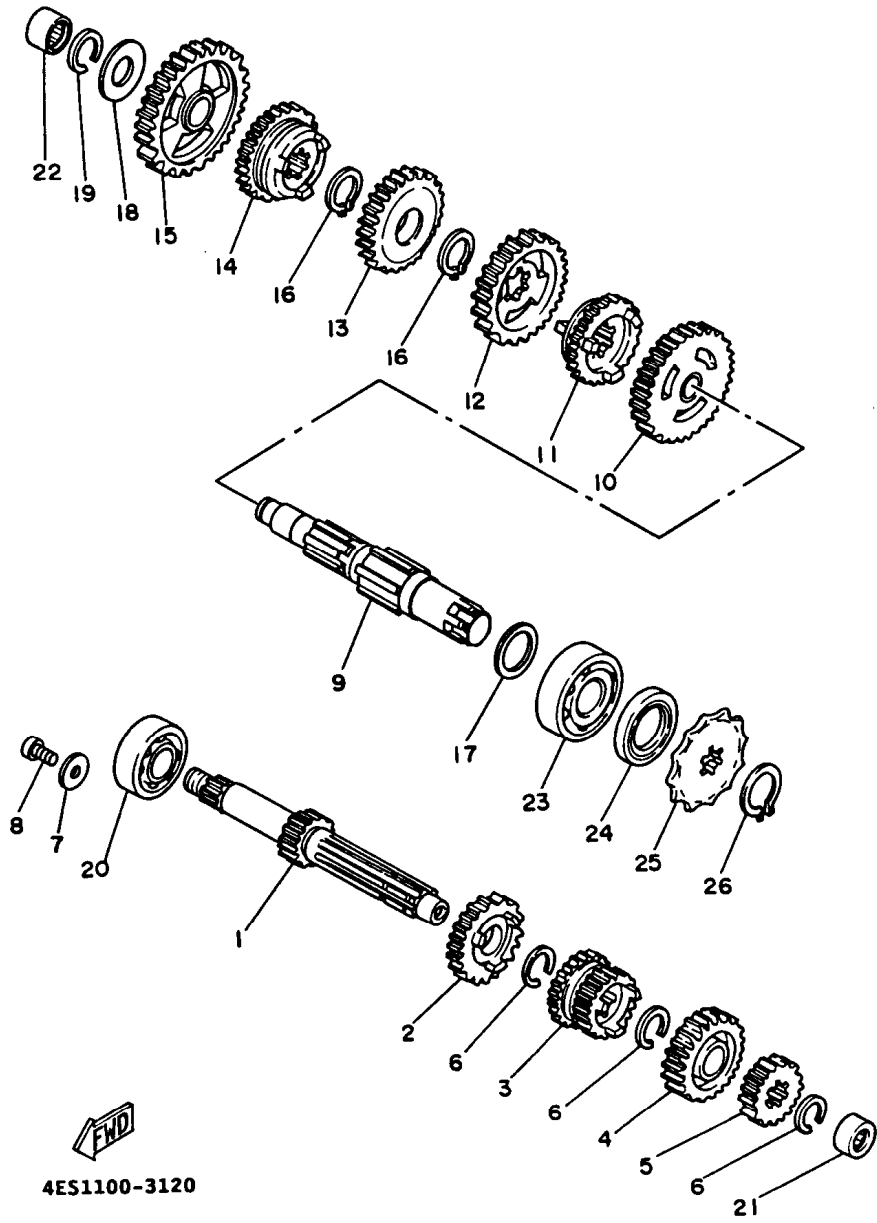

4ES1100-3120

B15

FIG. 13 SHIFT CAM. FORK

REF. NO.	PART NO.	DESCRIPTION	Q'TY	REMARKS
1	4ES-18540-00	SHIFT CAM ASSY	1	
2	4ES-18511-00	FORK, SHIFT 1	1	
3	4V0-18512-00	FORK, SHIFT 2	1	
4	4ES-18513-00	FORK, SHIFT 3	1	
5	90250-06013	PIN, STRAIGHT	3	
6	4BA-18531-00	BAR, SHIFT FORK GUIDE 1	1	
7	4BA-18535-00	BAR, SHIFT FORK GUIDE 2	1	
8	99009-10400	CIRCLIP	1	

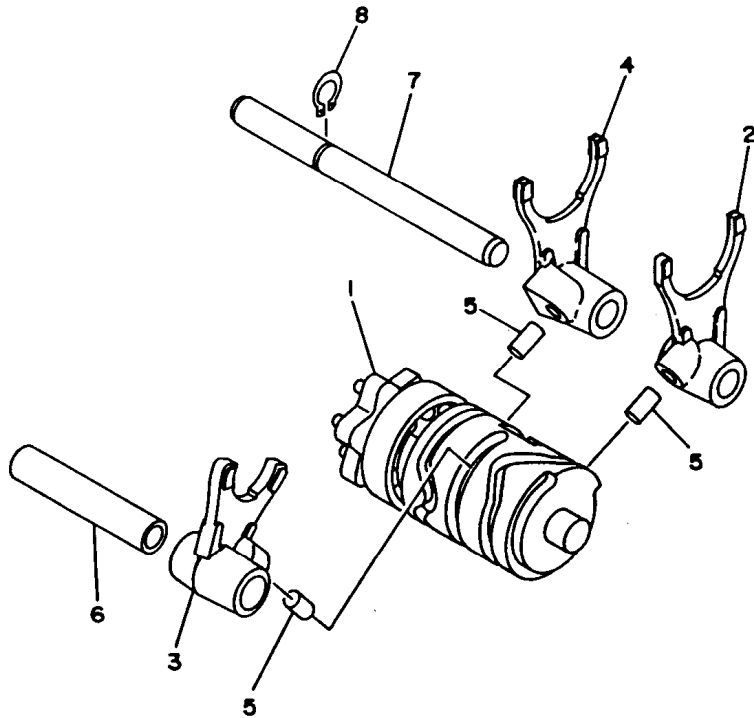

4ES3100-4130

C2

FIG. 14 SHIFT SHAFT

REF. NO.	PART NO.	DESCRIPTION	Q'TY	REMARKS
1	4ES-18101-00	SHIFT SHAFT ASSY	1	
2	90508-32553	SPRING, TORSION	1	
3	90508-242A6	SPRING, TORSION	1	
4	90387-126Y7	COLLAR	1	
5	99006-10600	CIRCLIP	3	
6	4BA-18140-00	STOPPER LEVER ASSY	1	
7	93101-12060	OIL SEAL	1	
8	2HF-18110-01	SHIFT PEDAL ASSY	1	
9	97027-06020	BOLT	1	

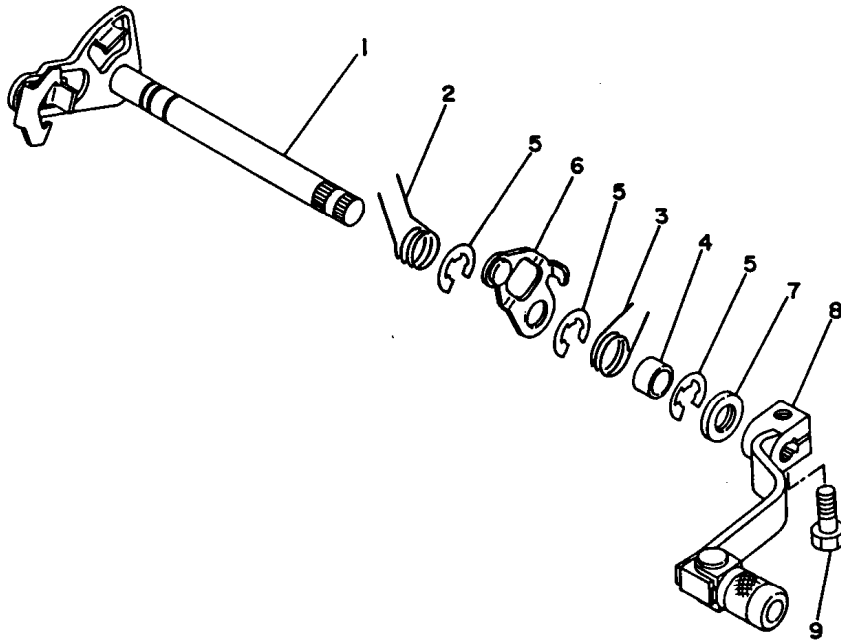

4ES1100-3140

C3

FIG. 15 FRAME

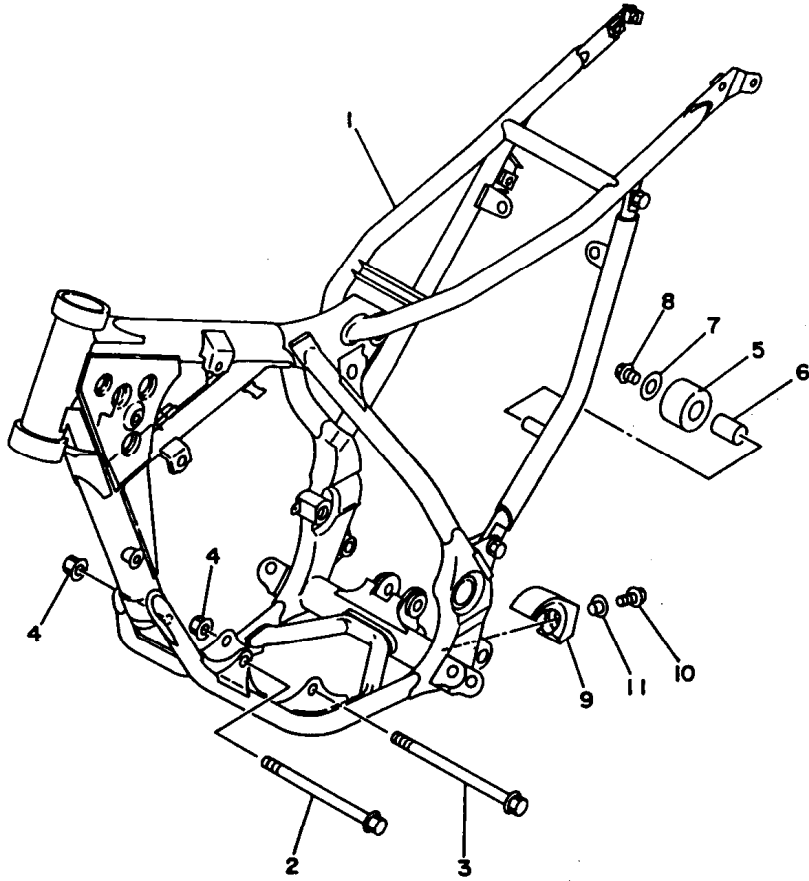

REF. NO.	PART NO.	DESCRIPTION	Q'TY	REMARKS
1	4ES-21110-01-P1	FRAME COMP.	1	BLUISH PURPLE SOLID 3
2	95817-08125	BOLT, FLANGE	1	
3	95817-08135	BOLT, FLANGE	1	
4	95607-08200	NUT, SELF-LOCKING	2	
5	30X-22178-00	TENSIONER	1	
6	4V4-22184-00	BUSH	1	
7	90201-081R9	WASHER, PLATE	1	
8	95027-08012	BOLT	1	
9	4ES-22178-00	TENSIONER	1	
10	90119-06118	BOLT, WITH WASHER	1	
11	90387-06216	COLLAR	1	



4ES1100-3150

C4

FIG. 16 FENDER

REF. NO.	PART NO.	DESCRIPTION	Q'TY	REMARKS
1	4ES-21511-00	FENDER, FRONT	1	
2	90119-06063	BOLT, WITH WASHER	4	
3	90209-06187	WASHER	4	
4	4ES-21611-00	FENDER, REAR	1	
5	95027-06016	BOLT	4	
6	90387-064X4	COLLAR	4	
7	4ES-21642-00	GUARD, FLAP	1	
8	90119-06185	BOLT, WITH WASHER	2	
9	3CV-28371-00	DAMPER	1	YZ80LW MODEL

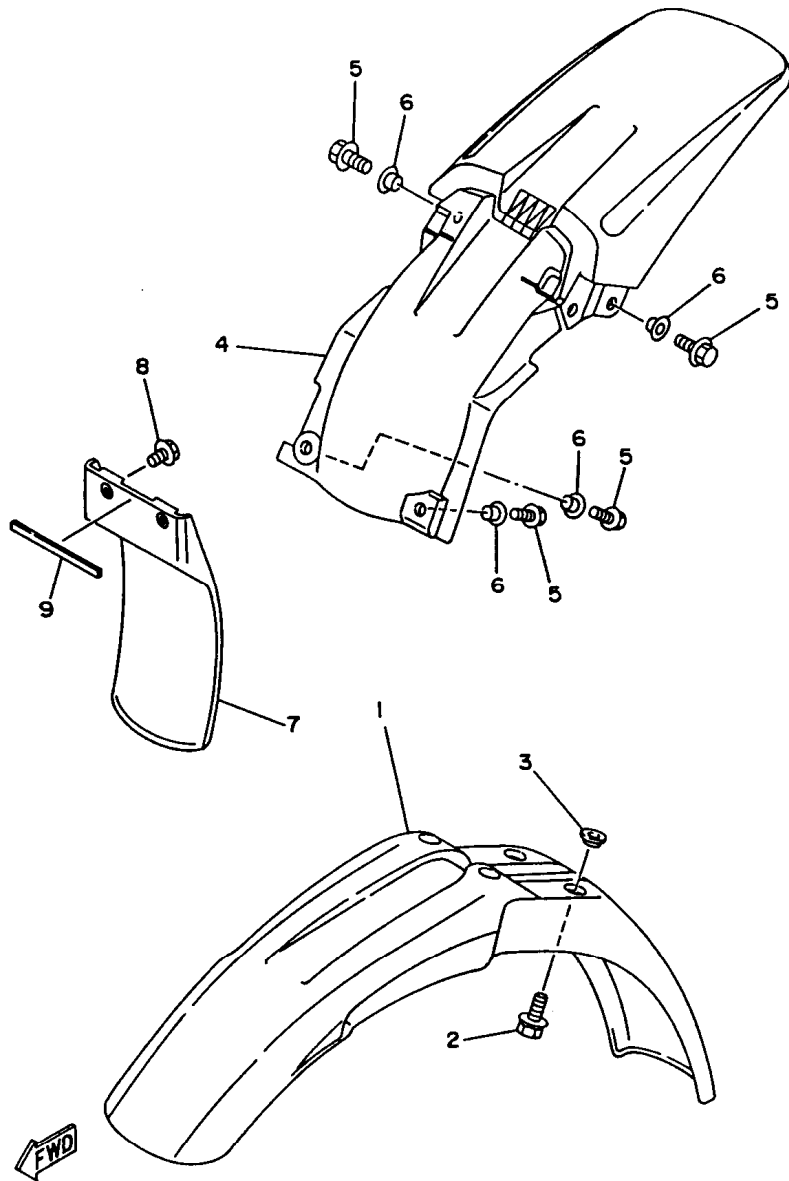

4ES4100-5160

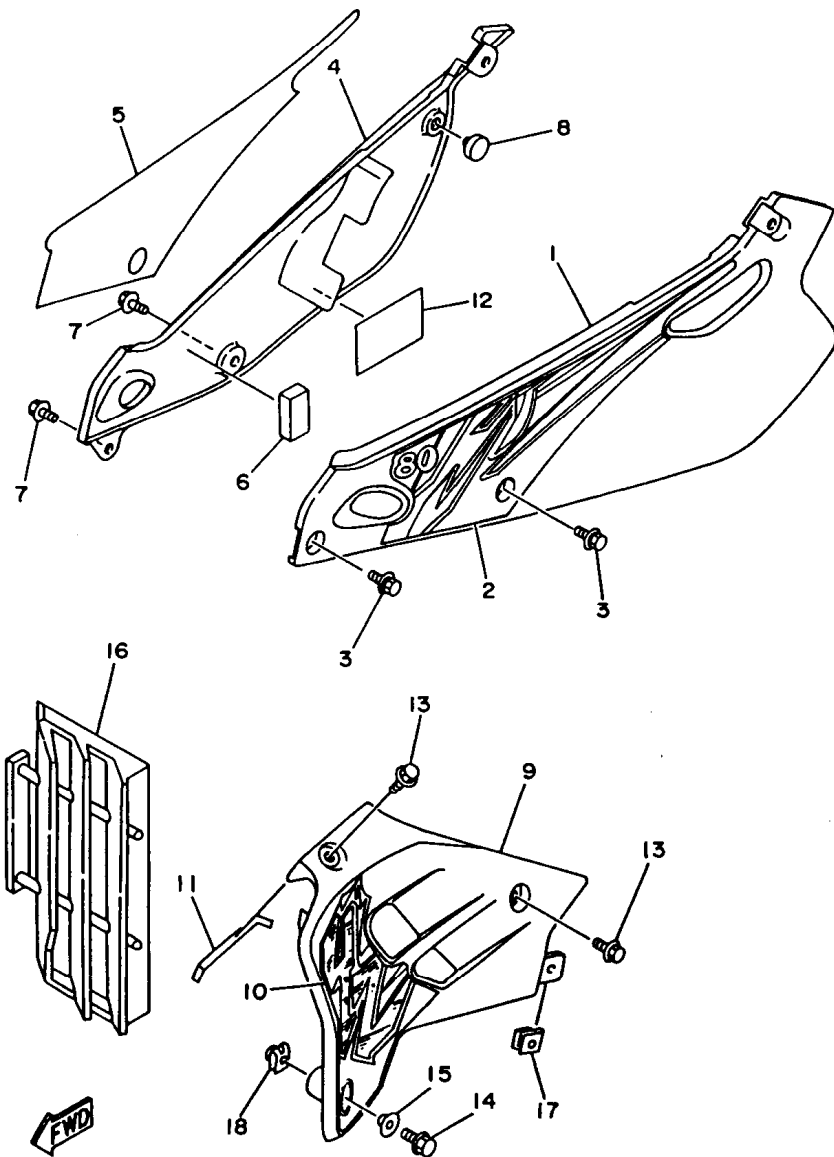

4ES4100-5170

FIG. 17 SIDE COVER

REF. NO.	PART NO.	DESCRIPTION	Q'TY	REMARKS
1	4ES-21711-00	COVER, SIDE 1	1	
2	4ES-2173E-20	GRAPHIC 1	1	
3	90119-06217	BOLT, WITH WASHER	2	
4	4ES-21721-00	COVER, SIDE 2	1	
5	4ES-2173F-20	GRAPHIC 2	1	
6	4ES-21735-00	SEAL 2	1	
7	90119-06217	BOLT, WITH WASHER	2	
8	22W-24181-00	DAMPER, LOCATING 1	1	
9	4ES-21731-00	COVER, SIDE 3	1	
10	4ES-21783-20	EMBLEM 3	1	
11	4ES-21732-00	SEAL 1	1	
12	4DJ-2174A-00	INSULATOR, SIDE COVER	1	
13	90109-067F4	BOLT	2	
14	95027-06016	BOLT, FLANGE	1	
15	90387-062M9	COLLAR	1	
16	4EW-2172A-00	PANEL 1	1	
17	90183-06023	NUT, SPRING	1	
18	90183-06069	NUT, SPRING	1	

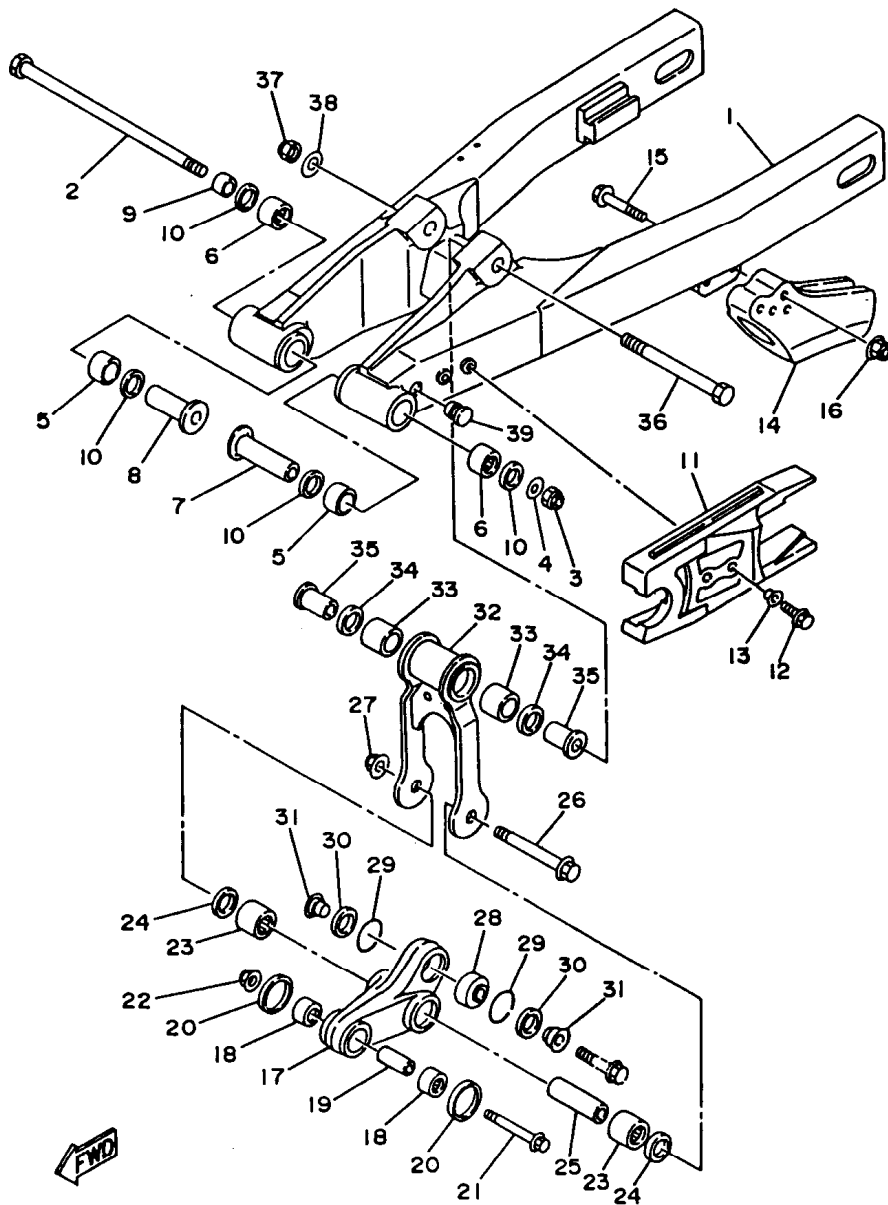

4ES4100-5180

FIG. 18 REAR ARM

REF. NO.	PART NO.	DESCRIPTION	Q'TY	REMARKS
1	4ES-22110-00	REAR ARM COMP.	1	UR
	4LB-22110-00	REAR ARM COMP.	1	UR YZ80LW MODEL
2	22W-25181-01	AXLE, WHEEL	1	
3	90185-12119	NUT, SELF-LOCKING	1	
4	90201-12469	WASHER, PLATE	1	
5	90385-17042	BUSH	2	
6	93317-21746	BEARING, CYLINDRICAL	2	
7	90387-127J8	COLLAR	1	
8	90387-127J7	COLLAR	1	
9	90387-1200U	COLLAR	1	
10	93109-17048	OIL SEAL (SDO 17-24-4)	4	
11	4ES-22151-00	SEAL, GUARD	1	
12	95027-06014	BOLT, FLANGE	2	
13	90387-062X0	COLLAR	2	
14	39K-22199-00	SUPPORT, CHAIN	1	
15	90105-08310	BOLT, WASHER BASED	2	
16	95607-08200	NUT, SELF-LOCKING	2	
17	4ES-2217A-00	ARM, RELAY	1	
18	93315-31449	BEARING, CYLINDRICAL	2	
19	90380-10218	BUSH, SOLID	1	
20	4ES-22129-00	COVER, THRUST 2	2	
21	90105-10582	BOLT, WASHER BASED	1	
22	95607-10200	NUT, SELF-LOCKING	1	
23	93315-31748	BEARING, CYLINDRICAL	2	
24	93101-17062	OIL SEAL	2	
25	90380-12219	BUSH, SOLID	1	
26	90105-12382	BOLT, WASHER BASED	1	
27	95607-12200	NUT, SELF-LOCKING	1	

C7

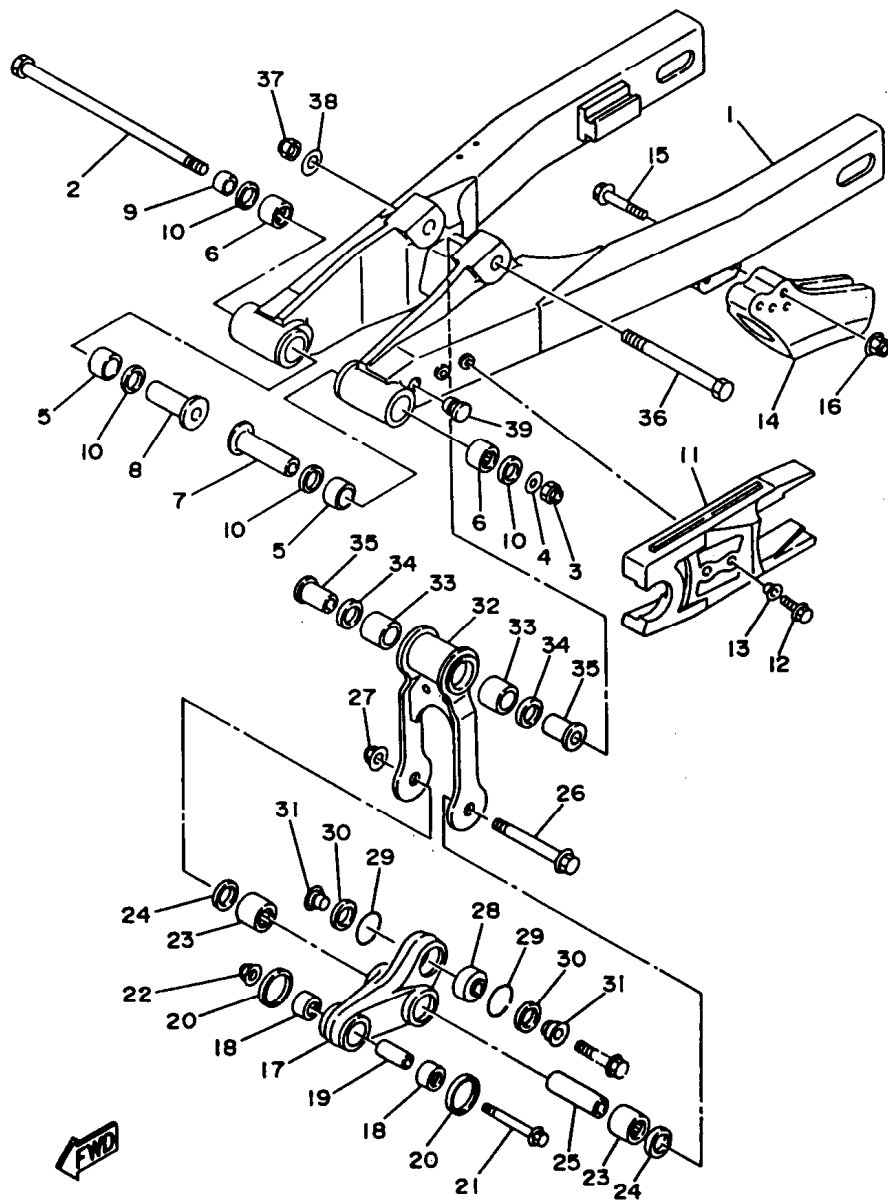

4ES4100-5180

FIG. 18 REAR ARM

REF. NO.	PART NO.	DESCRIPTION	Q'TY	REMARKS
28	93399-99921	BEARING	1	
29	93440-30113	CIRCLIP	2	
30	3XJ-22475-00	SEAL, DUST	2	
31	90387-103X9	COLLAR	2	
32	4ES-2217F-00	ROD, CONNECTING 1	1	
33	93315-31748	BEARING, CYLINDRICAL	2	
34	93101-17062	OIL SEAL	2	
35	90381-12091	BUSH, SOLID	2	
36	90101-12755	BOLT	1	
37	90185-12119	NUT, SELF-LOCKING	1	
38	90201-12749	WASHER, PLATE	1	
39	90338-10150	PLUG	2	

FIG. 19 REAR SUSPENSION

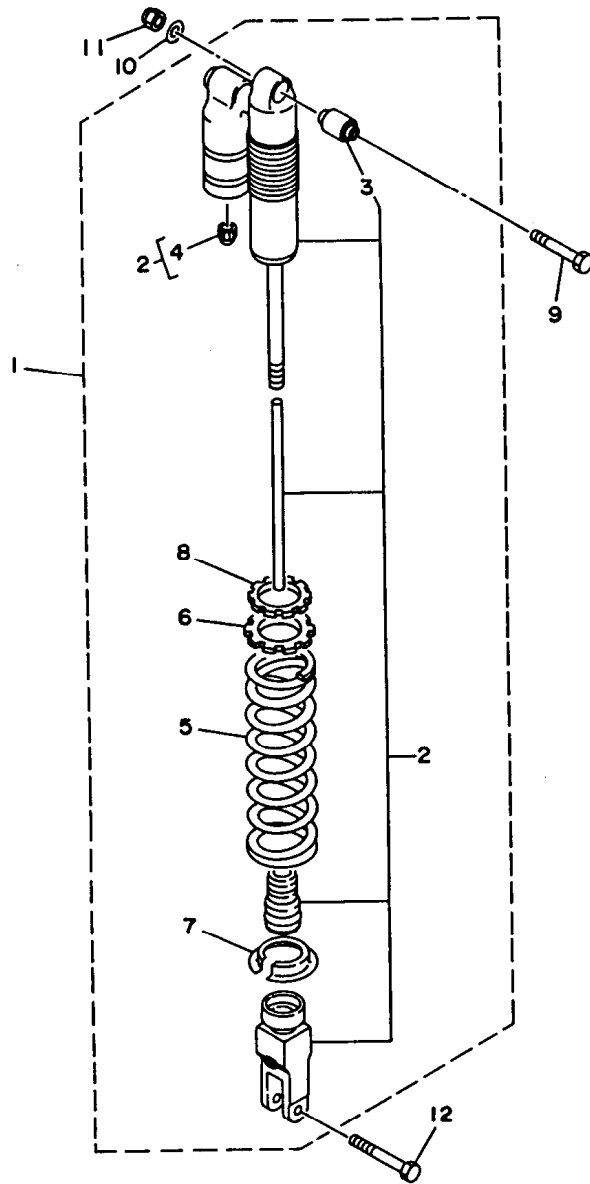

REF. NO.	PART NO.	DESCRIPTION	Q'TY	REMARKS
1	4ES-22210-60	SHOCK ABSORBER ASSY, REAR	1	UR FOR USA
	4ES-22210-70	SHOCK ABSORBER ASSY, REAR	1	UR FOR CANADA
	4ES-22210-80	SHOCK ABSORBER ASSY, REAR	1	UR FOR NEWZEALAND, S.AFRICA
	4LB-22210-20	SHOCK ABSORBER ASSY, REAR	1	UR YZ80LW MODEL
2	4ES-22201-30	.DAMPER SUB ASSY	1	UR FOR USA
	4ES-22201-40	.DAMPER SUB ASSY	1	UR FOR CANADA
	4ES-22201-50	.DAMPER SUB ASSY	1	UR FOR NEWZEALAND, S.AFRICA
	4LB-22201-00	.DAMPER SUB ASSY	1	UR YZ80LW MODEL
3	4ES-22216-00	..BUSH, REAR SHOCK ABSORBER	1	
4	58T-23184-L0	..CAP, AIR VALVE	1	
5	4ES-22212-70	.SPRING (K=5.0)	1	UR
	4ES-22212-90	.SPRING (K=5.2)	1	UR YZ80LW MODEL
6	4ES-22214-00	.GUIDE, SPRING 1	1	
7	3JD-22214-00	.GUIDE, SPRING 1	1	
8	4ES-22251-00	.NUT 1	1	
9	90109-10729	BOLT	1	
10	92907-10600	WASHER, PLATE	1	
11	90185-10120	NUT, SELF-LOCKING	1	
12	90105-10614	BOLT, WASHER BASED	1	

4ES100-3190

C9

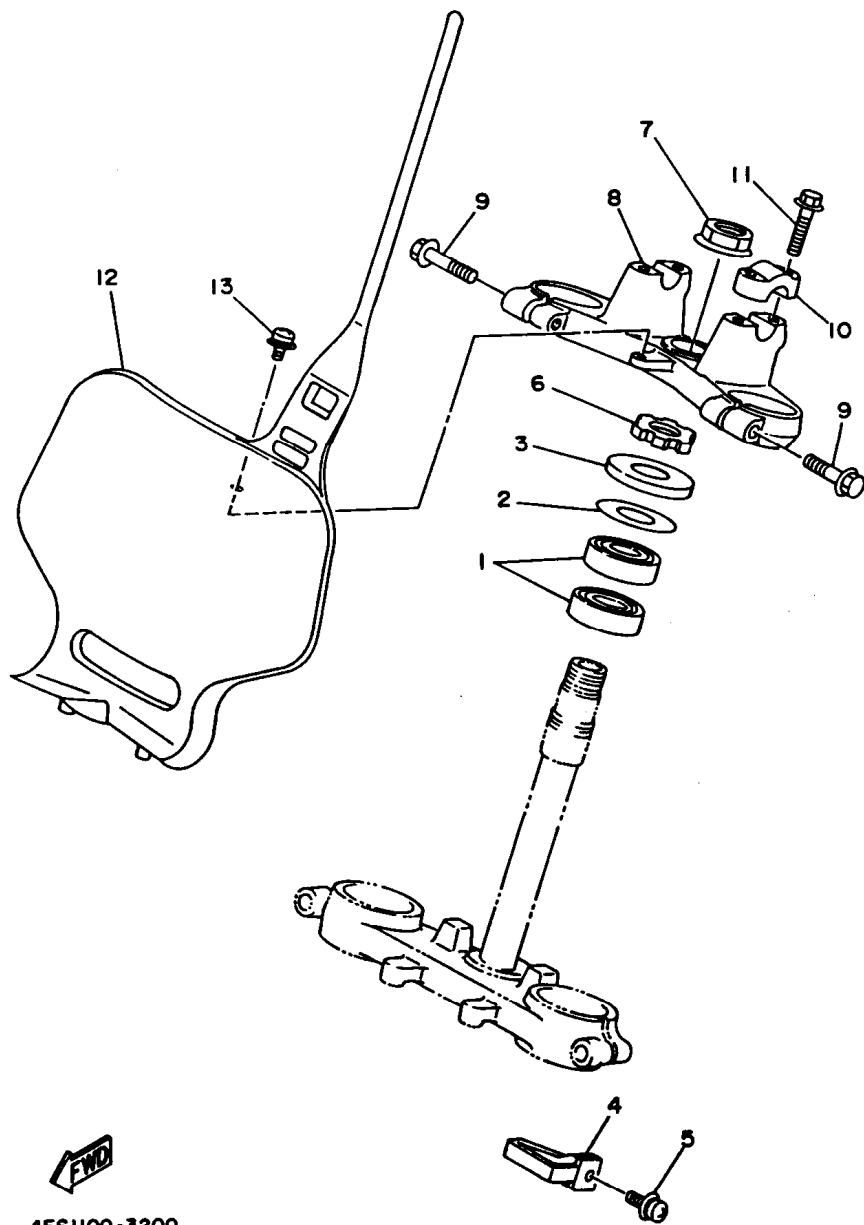

FIG. 20 STEERING

REF. NO.	PART NO.	DESCRIPTION	Q'TY	REMARKS
1	93332-00079	BEARING	2	
2	90201-256K5	WASHER, PLATE (0.5T)	1	
3	1J7-23415-00	COVER, BALL RACE 1	1	
4	4DA-23389-00	GUIDE, CABLE	1	
5	90159-05122	SCREW, WITH WASHER	1	
6	90179-25033	NUT	1	
7	90179-22412	NUT	1	
8	4ES-23435-00	CROWN, HANDLE	1	
9	95807-08035	BOLT, FLANGE	2	
10	3SP-23441-00	HOLDER, HANDLE UPPER	2	
11	95027-08030	BOLT, FLANGE	4	
12	4ES-23485-00	PLATE, NUMBER	1	
13	95027-06012	BOLT, FLANGE	1	

FWD
4ES1100-3200

C10

FIG. 21 FRONT FORK

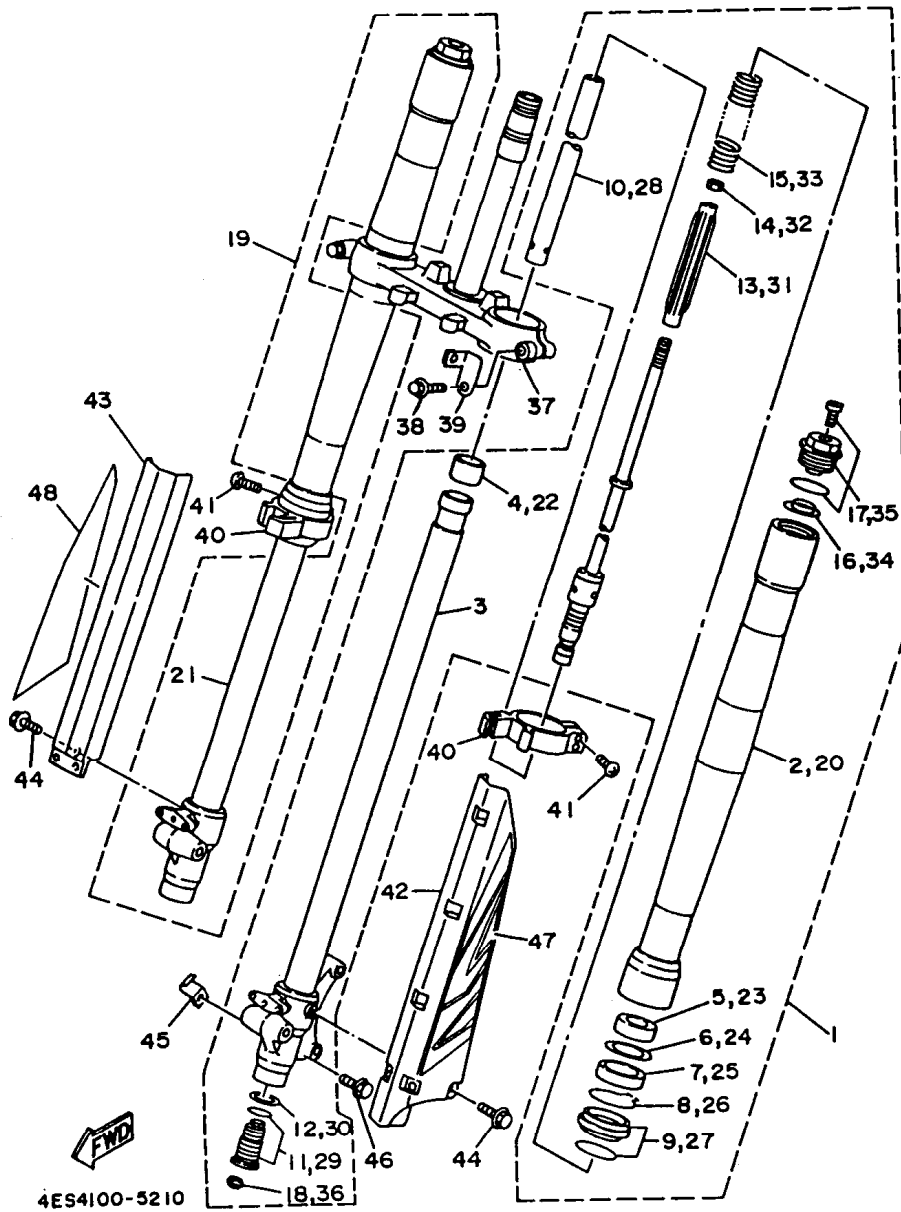

REF. NO.	PART NO.	DESCRIPTION	Q'TY	REMARKS
1	4ES-23102-10	FRONT FORK ASSY (L.H)	1	UR
	4LB-23102-10	FRONT FORK ASSY (L.H)	1	UR YZ80LW MODEL
2	4ES-23136-00	.TUBE, OUTER (RIGHT)	1	
3	4ES-23120-00	.INNER TUBE COMP. 2	1	
4	4ES-23171-00	.PISTON, FRONT FORK	1	
5	4ES-23125-00	.METAL, SLIDE 1	1	
6	5K5-23149-00	.WASHER, SPRING UPPER	1	
7	4ES-23145-00	.OIL SEAL	1	
8	4A1-23156-00	.CLIP, OIL SEAL	1	
9	4ES-23144-00	.SEAL, DUST	1	
10	4ES-23170-10	.CYLINDER COMP., FRONT FORK	1	
11	4ES-2316A-10	.VALVE COMP.	1	
12	2HH-23158-L0	.GASKET	1	
13	4ES-23142-00	.SEAT, SPRING UPPER	1	
14	3XJ-23357-L0	.NUT	1	
15	4ES-23141-00	.SPRING, FRONT FORK (K=0.29)	1	UR
	4LB-23141-00	.SPRING, FRONT FORK (K=0.30)	1	UR YZ80LW MODEL
16	4V4-23142-L0	.SEAT, SPRING UPPER	1	
17	4ES-23111-10	.BOLT, CAP	1	
18	3JD-23126-L0	.PLUG	1	
19	4ES-23103-10	FRONT FORK ASSY (R.H)	1	UR
	4LB-23103-10	FRONT FORK ASSY (R.H)	1	UR YZ80LW MODEL
20	4ES-23136-00	.TUBE, OUTER (RIGHT)	1	
21	4ES-23110-00	.INNER TUBE COMP. 1	1	
22	4ES-23171-00	.PISTON, FRONT FORK	1	
23	4ES-23125-00	.METAL, SLIDE 1	1	
24	5K5-23149-00	.WASHER, SPRING UPPER	1	
25	4ES-23145-00	.OIL SEAL	1	

FIG. 21 FRONT FORK

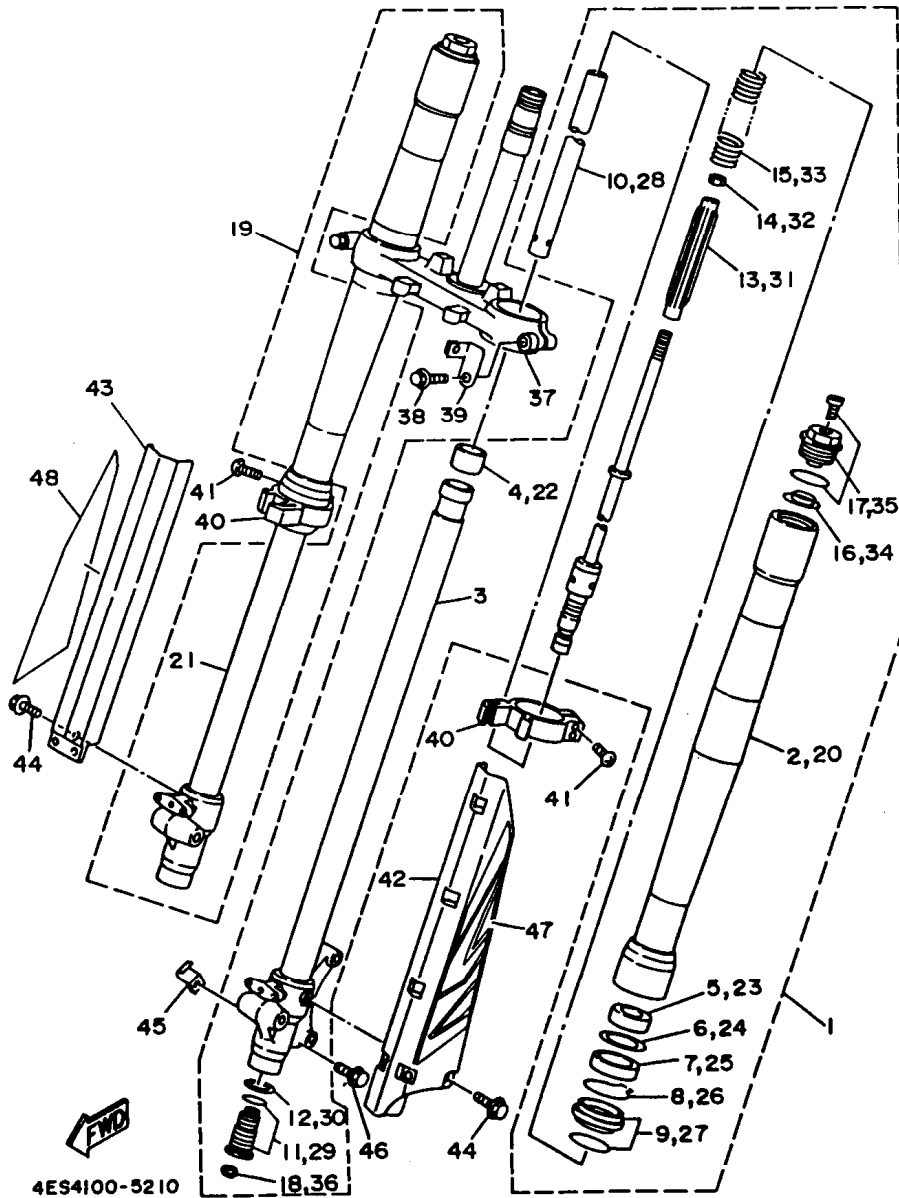

REF. NO.	PART NO.	DESCRIPTION	Q'TY	REMARKS
26	4A1-23156-00	.CLIP, OIL SEAL	1	
27	4ES-23144-00	.SEAL, DUST	1	
28	4ES-23170-10	.CYLINDER COMP., FRONT FORK	1	
29	4ES-2316A-10	.VALVE COMP.	1	
30	2HH-23158-L0	.GASKET	1	
31	4ES-23142-00	.SEAT, SPRING UPPER	1	
32	3XJ-23357-L0	.NUT	1	
33	4ES-23141-00	.SPRING, FRONT FORK (K=0.29)	1	UR
	4LB-23141-00	.SPRING, FRONT FORK (K=0.30)	1	UR YZBOLW MODEL
34	4V4-23142-L0	.SEAT, SPRING UPPER	1	
35	4ES-23111-10	.BOLT, CAP	1	
36	3JD-2312G-L0	.PLUG	1	
37	4ES-23340-00	UNDER BRACKET COMP.	1	
38	95021-10040	BOLT, FLANGE	2	
39	4ES-2331E-00	GUIDE, CABLE	1	
40	4ES-2314F-00	PROTECTOR GUIDE COMP. 1	2	
41	4V4-23194-L0	SCREW, BOOT BAND	4	
42	4ES-2314H-L1	PROTECTOR COMP. 1	1	
43	4ES-2314J-L0	PROTECTOR COMP. 2	1	
44	4DA-23346-L0	BOLT 1	6	
45	4ES-23318-00	HOLDER, CABLE 1	1	
46	95027-06016	BOLT, FLANGE	1	
47	4ES-2313B-20	EMBLEM1	1	
48	4ES-2313C-20	EMBLEM2	1	

C12

FIG. 22 FUEL TANK

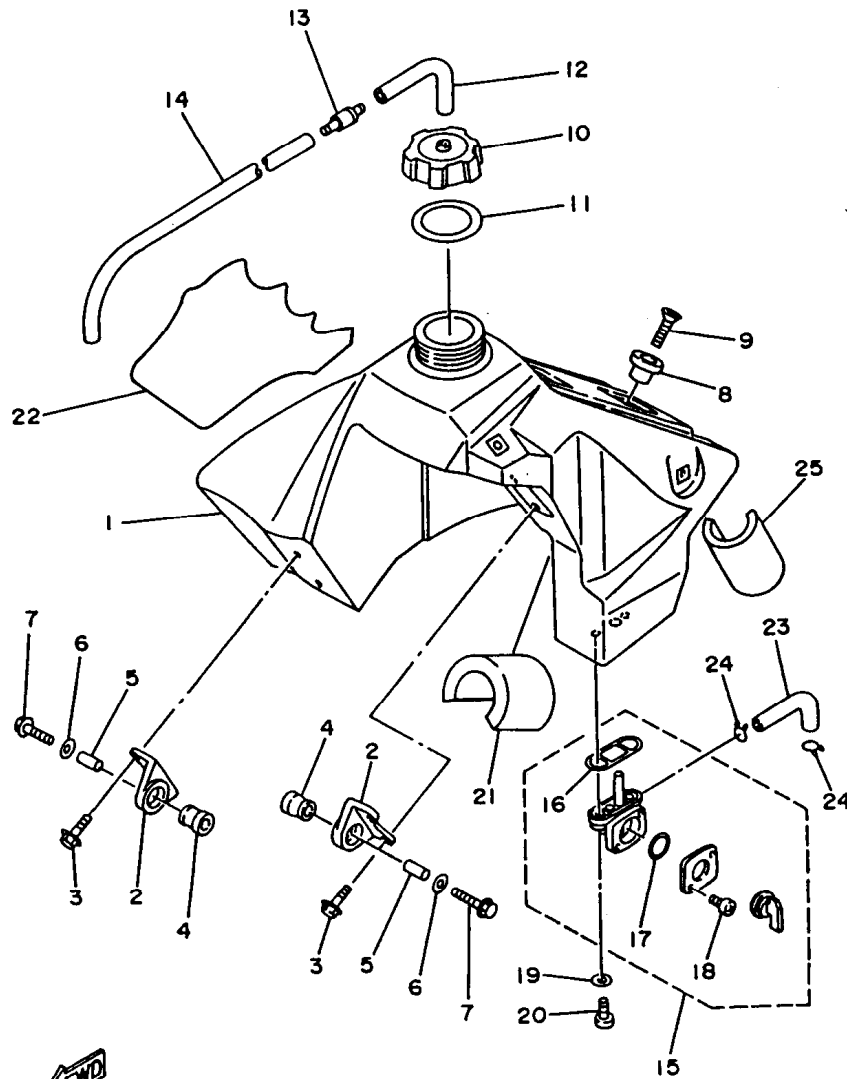

REF. NO.	PART NO.	DESCRIPTION	Q'TY	REMARKS
1	4ES-24110-00	FUEL TANK COMP.	1	
2	24X-24144-00	HOLDER, DAMPER	2	
3	95027-06016	BOLT, FLANGE	4	
4	90480-18549	GROMMET	2	
5	90387-06027	COLLAR	2	
6	90201-06697	WASHER, PLATE	2	
7	95027-06030	BOLT, FLANGE	2	
8	4EW-2412F-00	BRACKET, SEAT	1	
9	98707-06025	SCREW, FLAT HEAD	1	
10	5X7-24611-01	BODY, CAP	1	
11	5X7-24612-00	GASKET, CAP	1	
12	90445-09055	HOSE	1	
13	3XJ-24380-00	PIPE JOINT ASSY	1	
14	90445-09100	HOSE	1	
15	2VN-24500-01	FUEL COCK ASSY 1	1	
16	4X8-24512-00	.O-RING	1	
17	3AJ-24534-00	.SEAL, COCK	1	
18	98580-03008	.SCREW, PAN HEAD	2	
19	90202-05193	WASHER, PLATE	2	
20	90149-06011	SCREW	2	
21	3Y0-24183-00	DAMPER, LOCATING 3	1	
22	4ES-24161-20	EMBLEM 1	1	
23	4ES-24311-10	PIPE, FUEL 1	1	
24	90467-10008	CLIP	2	
25	51L-28371-00	DAMPER	1	

4ES4100-5220

C13

FIG. 23 SEAT

REF. NO.	PART NO.	DESCRIPTION	Q'TY	REMARKS
1	4ES-24770-10	SEMI-DOUBLE SEAT ASSY	1	BLUISH PURPLE SOLID 3
2	4ES-24731-10	.COVER, SEAT	1	BLUISH PURPLE SOLID 3
3	4ES-24728-00	.BRACKET, SEAT	2	
4	95027-06012	.BOLT, FLANGE	4	
5	95027-06020	BOLT, FLANGE	2	
6	92907-06200	WASHER	2	

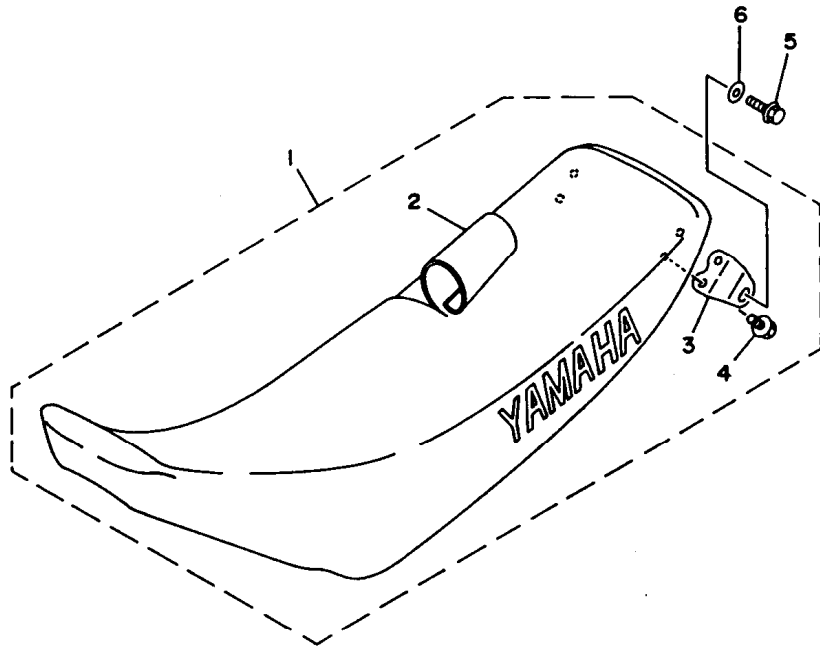

4ES3100-4230

C14

FIG. 24 FRONT WHEEL

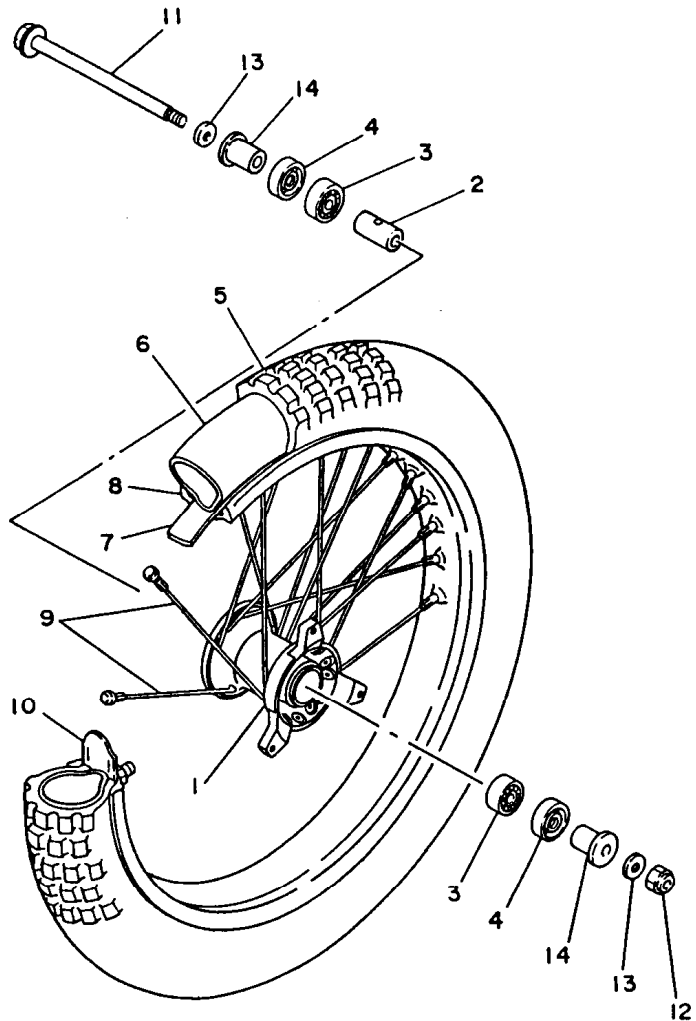

REF. NO.	PART NO.	DESCRIPTION	Q'TY	REMARKS
1	4ES-25111-00	HUB, FRONT	1	
2	90387-124H0	COLLAR	1	
3	93306-20117	BEARING	2	
4	93106-20031	OIL SEAL	2	
5	94107-177Y5	TIRE (70/100-17 40M K490)	1	UR DUNLOP
	94107-1906D	TIRE (70/100-19 42M D752F)	1	UR DUNLOP YZ80LW MODEL
6	94207-17284	TUBE (70/100-17 TR4)	1	UR DUNLOP
	94207-19290	TUBE (70/100-19 TR4)	1	UR DUNLOP YZ80LW MODEL
7	94307-17166	BAND, RIM (80/90,70/100-17)	1	UR DUNLOP
	94307-19170	BAND, RIM (70-100-19)	1	UR DUNLOP YZ80LW MODEL
8	94414-17530	RIM (1.40-17)	1	UR
	94414-19521	RIM (1.40-19)	1	UR YZ80LW MODEL
9	4ES-25104-20	SPOKE SET, FRONT	1	UR
	4LB-25104-00	SPOKE SET, FRONT	1	UR YZ80LW MODEL
10	1T1-25194-00	SPACER, BEAD	1	
11	4ES-25181-00	AXLE, WHEEL	1	
12	90185-12046	NUT, SELF-LOCKING	1	
13	90201-12362	WASHER, PLATE	2	
14	4ES-25183-10	COLLAR, WHEEL	2	



4ES1100-3240

C15

FIG. 25 FRONT BRAKE CALIPER

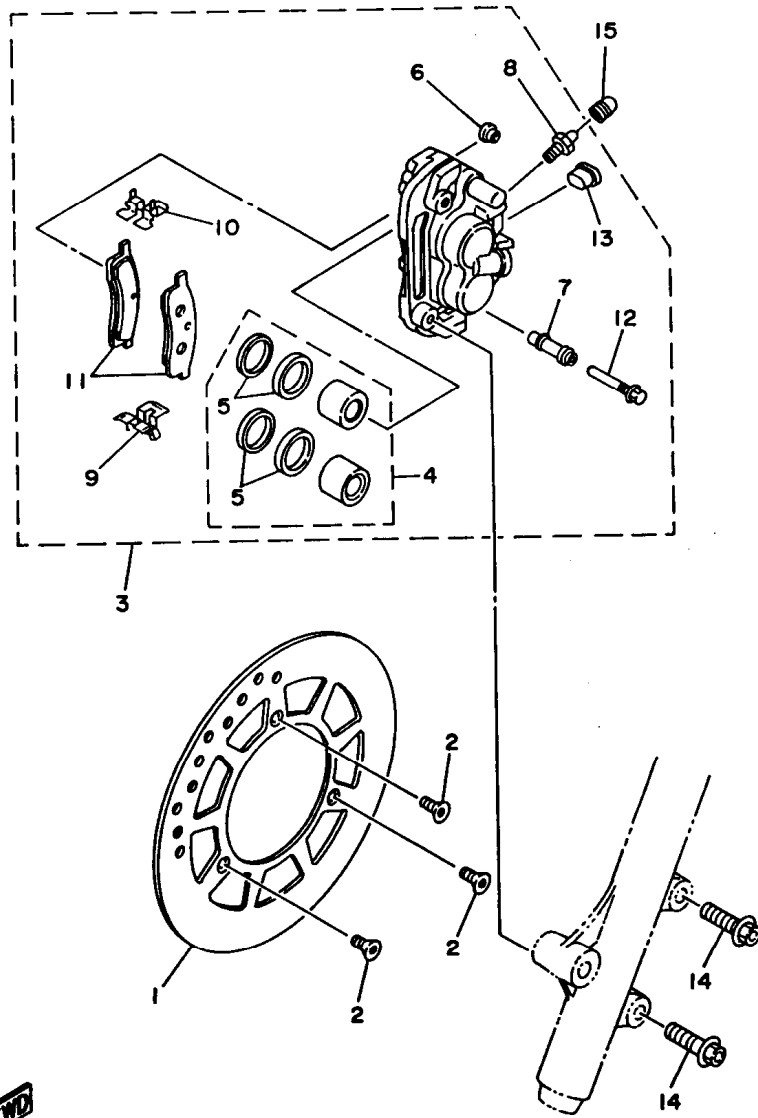

REF. NO.	PART NO.	DESCRIPTION	Q'TY	REMARKS
1	4ES-2582T-00	DISC, BRAKE	1	
2	90149-06272	SCREW	3	
3	4ES-2580T-00	CALIPER ASSY (LEFT)	1	
4	1LR-W0057-00	.PISTON ASSY, CALIPER	1	
5	1LR-W0047-00	..CALIPER SEAL KIT	1	
6	5R2-25937-00	.BOOT 2	1	
7	56A-25937-00	.BOOT 2	1	
8	47X-25824-00	.SCREW, BREED	1	
9	56A-25919-00	.SUPPORT, PAD	1	
10	56A-25919-10	.SUPPORT, PAD	1	
11	4ES-W0045-00	.BRAKE PAD KIT	1	
12	56A-25926-00	.BOLT	1	
13	34X-25845-00	.CAP, INDICATOR	1	
14	90105-08211	BOLT, WASHER BASED	2	
15	51L-25825-00	CAP	1	



4ES3100-4250

D2

FIG. 26 REAR WHEEL

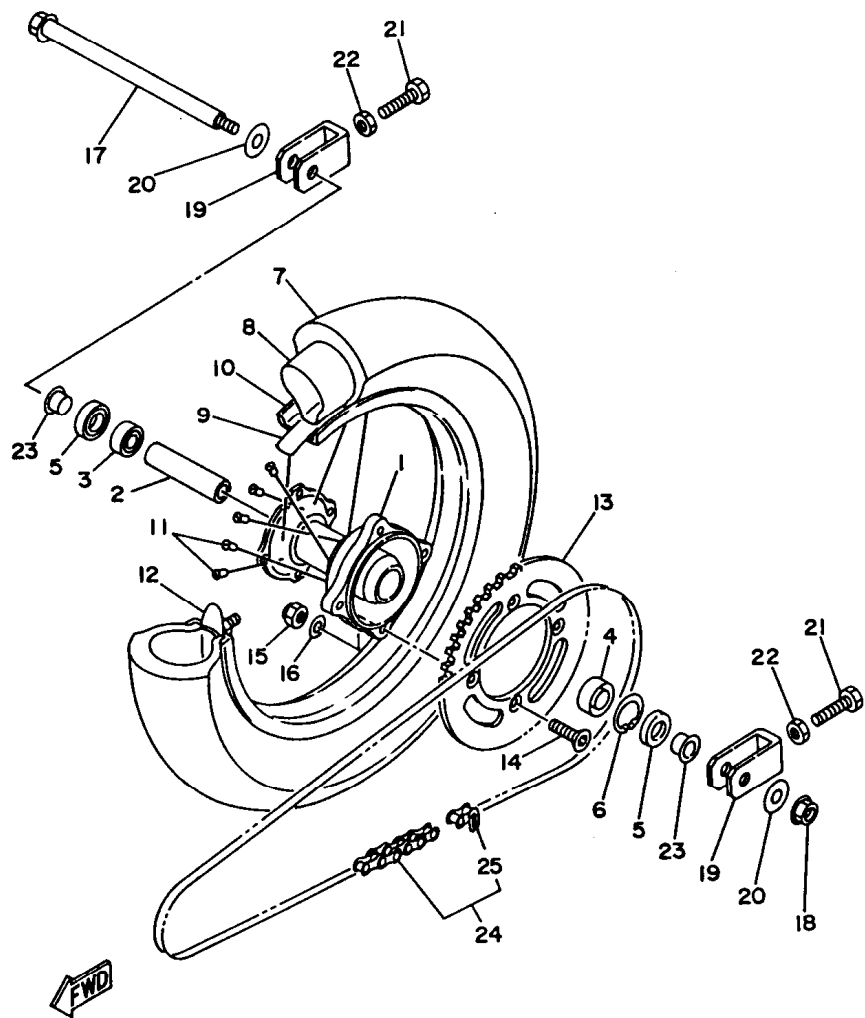

4ES1100-3260

D3

REF. NO.	PART NO.	DESCRIPTION	Q'TY	REMARKS
1	4ES-25311-00	HUB, REAR	1	
2	4ES-25383-00	COLLAR, WHEEL	1	
3	93306-00210	BEARING	1	
4	93306-20204	BEARING (B6202Z)	1	
5	93102-20009	OIL SEAL	2	
6	99009-35500	CIRCLIP	1	
7	94109-147Y6	TIRE (90/100-14 49M K695)	1	UR DUNLOP
	94109-1606E	TIRE (90/100-16 52M D752)	1	UR DUNLOP YZ80LW MODEL
8	94208-14285	TUBE (80-90/100-14 TR4)	1	UR DUNLOP
	94209-16291	TUBE (90/100-16 TR4)	1	UR DUNLOP YZ80LW MODEL
9	94308-14165	BAND, RIM (80-90/100-14)	1	UR DUNLOP
	94307-16171	BAND, RIM (70-90/100-16)	1	UR DUNLOP YZ80LW MODEL
10	94416-14529	RIM (1.60-14)	1	UR
	94418-16522	RIM (1.85-16)	1	UR YZ80LW MODEL
11	4ES-25304-20	SPOKE SET, REAR	1	UR
	4LB-25304-00	SPOKE SET, REAR	1	UR YZ80LW MODEL
12	5X2-25394-00	SPACER, BEAD	1	UR
	1T2-25394-00	SPACER, BEAD	1	UR YZ80LW MODEL
13	4ES-25447-00	SPROCKET, DRIVEN (47T)	1	STD
	4ES-25446-00	SPROCKET, DRIVEN (46T)	1	AP
	4ES-25448-00	SPROCKET, DRIVEN (48T)	1	AP
14	90109-081G2	BOLT	4	
15	95617-08100	NUT, U	4	
16	90201-086P8	WASHER, PLATE	4	
17	4ES-25381-01	AXLE, WHEEL	1	
18	95607-14200	NUT, SELF-LOCKING	1	
19	4ES-25388-00	PULLER, CHAIN 1	2	
20	90201-161R1	WASHER, PLATE	2	

FIG. 26 REAR, WHEEL

REF. NO.	PART NO.	DESCRIPTION	Q'TY	REMARKS
21	90101-08475	BOLT	2	
22	95307-08700	NUT	2	
23	4ES-25383-10	COLLAR, WHEEL	2	
24	9Y581-58117	CHAIN (DID428G2 118L)	1	UR
	9Y581-58119	CHAIN (DID428G2 120L)	1	UR YZ80LW MODEL
25	94681-58001	.JOINT, CHAIN (DID 428G2)	1	

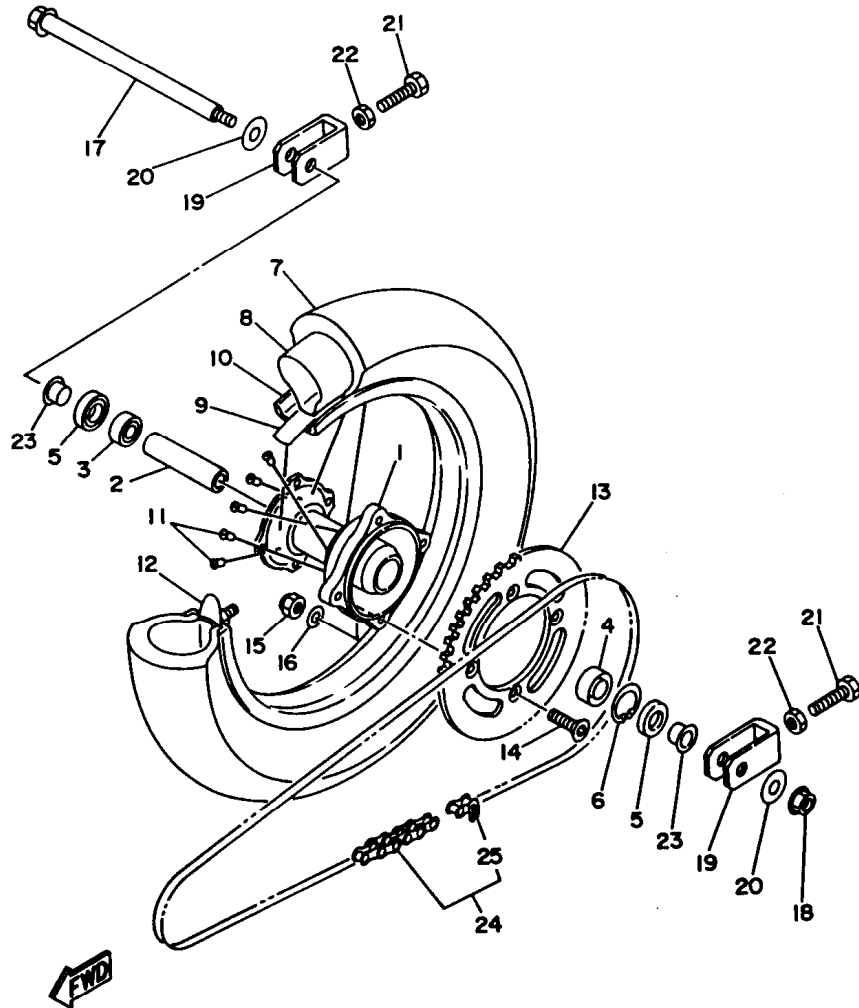

4ES1100-3260

D4

FIG. 27 REAR BRAKE CALIPER

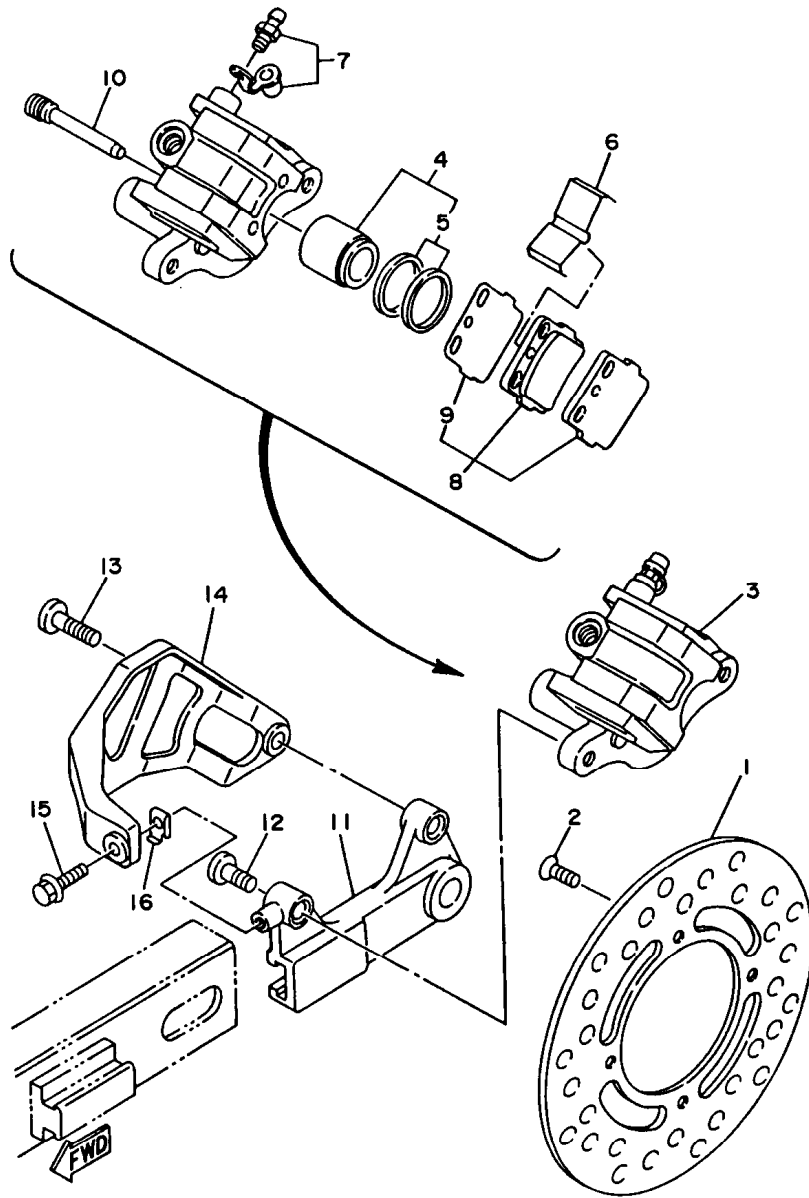

4ES1100-3270

REF. NO.	PART NO.	DESCRIPTION	Q'TY	REMARKS
1	4ES-2582W-00	DISC, REAR BRAKE 2	1	
2	90149-06272	SCREW	4	
3	4ES-2580W-00	CALIPER ASSY, REAR 2	1	
4	4ES-W0057-00	.PISTON ASSY, CALIPER	1	
5	4ES-W0047-00	..CALIPER SEAL KIT	1	
6	1UY-25919-51	.SUPPORT, PAD	1	
7	36Y-W0048-00	.BREED SCREW KIT	1	
8	4ES-W0046-50	.BRAKE PAD KIT 2	1	
9	3GD-25827-00	..SHIM, CALIPER	1	
10	3GD-25933-00	.PIN, PAD	2	
11	4ES-25920-00	SUPT. BRKT. ASSY	1	
12	90110-08096	BOLT, HEXAGON SOCKET HEAD	1	
13	90109-08718	BOLT	1	
14	4ES-27491-00	PROTECTOR	1	
15	95027-06012	BOLT	1	
16	4ES-27114-00	STOPPER, MAIN STAND	1	

D5

FIG. 28 STEERING HANDLE. CABLE

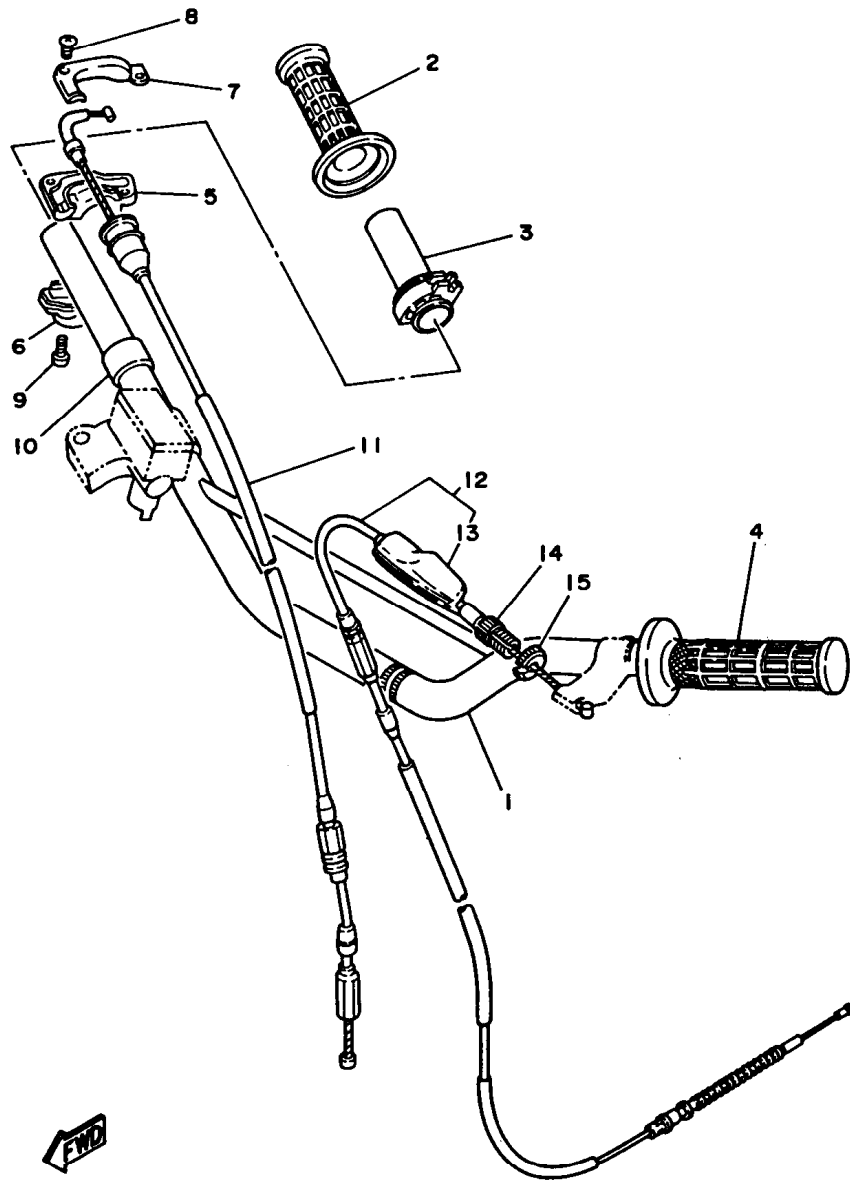

REF. NO.	PART NO.	DESCRIPTION	Q'TY	REMARKS
1	4ES-26111-00	HANDLEBAR	1	
2	1LX-26242-01	GRIP (RIGHT)	1	
3	22W-26243-00	TUBE, THROTTLE GUIDE	1	
4	1LX-26241-01	GRIP (LEFT)	1	
5	5X2-26281-00	CAP, GRIP UPPER	1	
6	322-26282-00	CAP, GRIP LOWER	1	
7	5X2-2628H-01	CAP, WIRE	1	
8	98707-04012	SCREW, FLAT HEAD	2	
9	98507-05016	SCREW, PAN HEAD	2	
10	90387-22647	COLLAR	1	
11	4ES-26311-00	CABLE, THROTTLE 1	1	
12	4ES-26335-00	CABLE, CLUTCH	1	
13	382-26372-01	.COVER, HANDLE LEVER 1	1	
14	90123-08013	BOLT	1	
15	90179-08148	NUT	1	

3MK4100-2270

D6

FIG. 29 FRONT MASTER CYLINDER

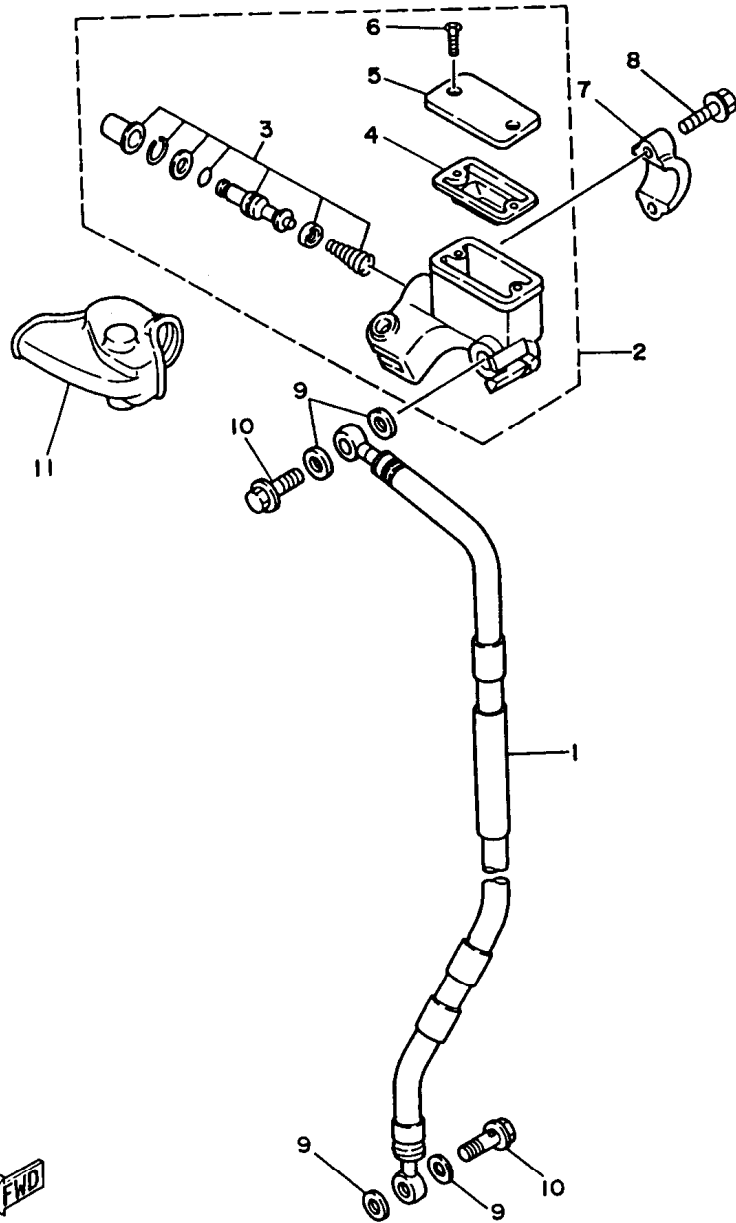

REF. NO.	PART NO.	DESCRIPTION	Q'TY	REMARKS
1	4ES-25872-01	HOSE, BRAKE 1	1	UR
	4LB-25872-01	HOSE, BRAKE 1	1	UR YZ80LW MODEL
2	2VN-25870-01	MASTER CYLINDER SUB ASSY	1	
3	56A-W0041-00	.CYLINDER KIT, MASTER	1	
4	56A-25854-00	.DIAPHRAGM, RESERVOIR	1	
5	2VN-25852-01	.CAP, RESERVOIR	1	
6	98706-04012	.SCREW, FLAT HEAD	2	
7	56A-25867-00	BRACKET, MASTER CYLINDER	1	
8	95027-06025	BOLT, FLANGE	2	
9	90201-10118	WASHER, PLATE	4	
10	90401-10159	BOLT, UNION	2	
11	56A-26372-01	COVER, HANDLE LEVER 1	1	



4ES1100-3290

D7

FIG. 30 STAND. FOOTREST

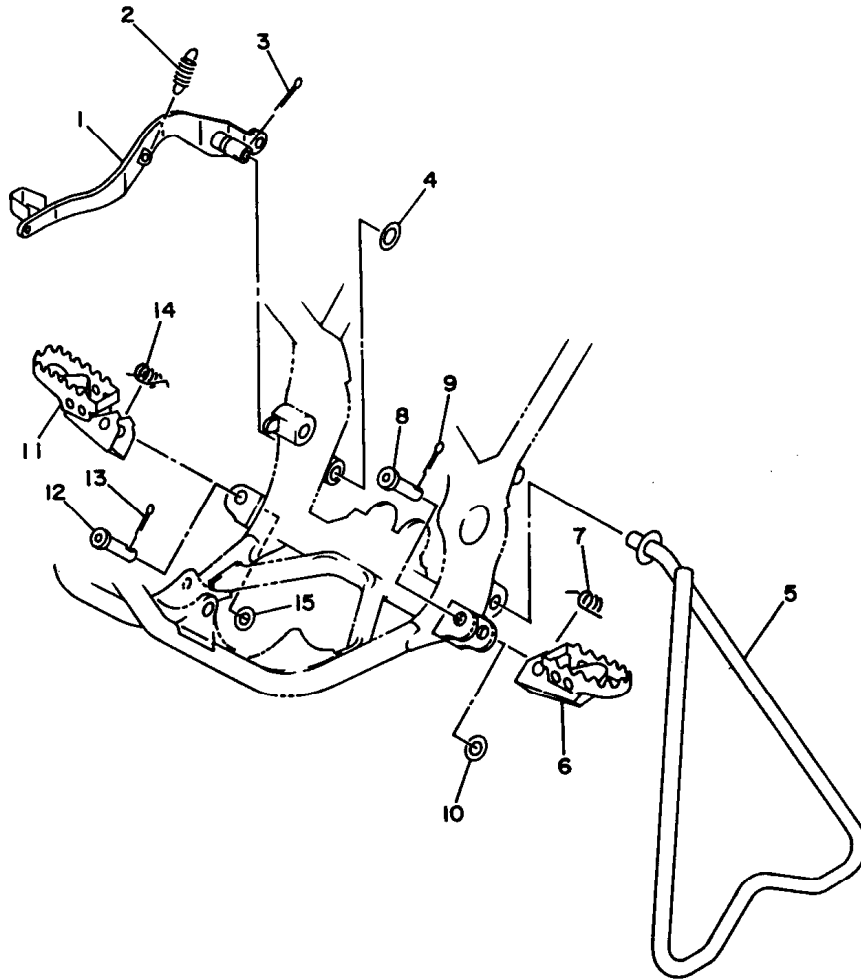

REF. NO.	PART NO.	DESCRIPTION	Q'TY	REMARKS
1	4ES-27211-00	PEDAL, BRAKE	1	
2	90506-15480	SPRING, TENSION	1	
3	91401-20030	PIN, COTTER	1	
4	90201-154E8	WASHER, PLATE	1	
5	4ES-27311-00	STAND, SIDE	1	UR
	4LB-27311-00	STAND, SIDE	1	UR YZ80LW MODEL
6	3LD-27411-00	FOOTREST 1	1	
7	90508-28777	SPRING, TORSION	1	
8	90240-10117	PIN, CLEVIS	1	
9	91401-25020	PIN, COTTER	1	
10	90201-10119	WASHER, PLATE	1	
11	3LD-27421-00	FOOTREST 2	1	
12	90240-10117	PIN, CLEVIS	1	
13	91401-25020	PIN, COTTER	1	
14	90508-28777	SPRING, TORSION	1	
15	90201-10119	WASHER, PLATE	1	



4ES1100-3300

D8

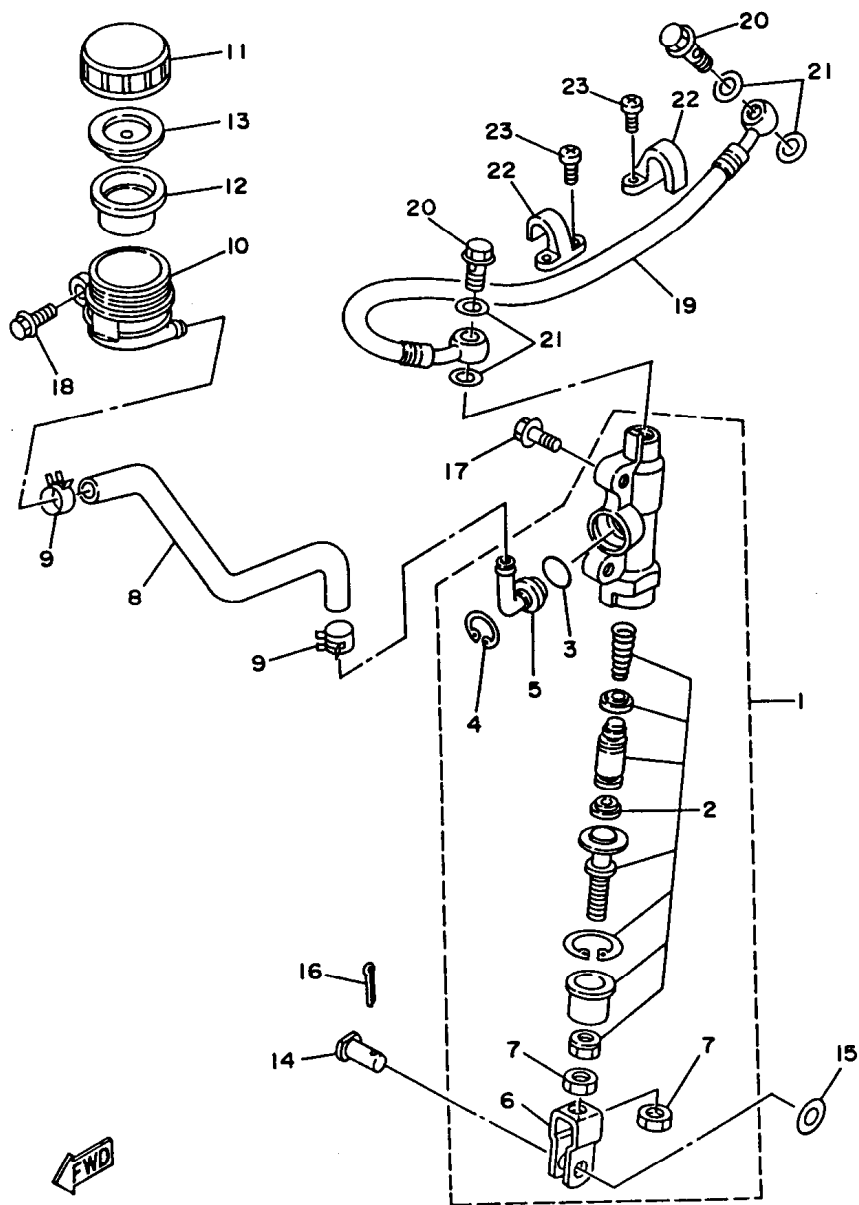

FIG. 31 REAR MASTER CYLINDER

REF. NO.	PART NO.	DESCRIPTION	Q'TY	REMARKS
1	4ES-2583V-00	RR. MASTER CYLINDER ASSY	1	
2	1FK-W0042-50	.CYLINDER KIT, MASTER	1	
3	93210-15620	.O-RING	1	
4	2VN-25866-00	.CIRCLIP	1	
5	2VN-2582A-50	.JOINT	1	
6	2YK-27222-00	.JOINT	1	
7	95307-08600	.NUT	2	
8	4ES-25895-00	HOSE, RESERVOIR	1	
9	90467-11044	CLIP	2	
10	4EW-25894-00	TANK, RESERVOIR	1	
11	3XP-25852-50	CAP, RESERVOIR	1	
12	2VN-25854-00	DIAPHRAGM, RESERVOIR	1	
13	2VN-25855-00	BUSH, DIAPHRAGM	1	
14	90240-08124	PIN, CLEVIS	1	
15	90201-08083	WASHER, PLATE	1	
16	91401-16020	PIN, COTTER	1	
17	95027-06016	BOLT	2	
18	95027-06012	BOLT	1	
19	4ES-25873-01	HOSE, BRAKE 2	1	UR
	4LB-25873-01	HOSE, BRAKE 2	1	UR YZ80LW MODEL
20	90401-10159	BOLT, UNION	2	
21	90201-10118	WASHER, PLATE	4	
22	2VM-25876-00	HOLDER, BRAKE HOSE 2	2	
23	97780-50110	SCREW, TAPPING	4	

FWD
4ES1100-3310

D9

FIG. 32 GENERATOR

REF. NO.	PART NO.	DESCRIPTION	Q'TY	REMARKS
1	4ES-85510-10	STATOR ASSY	1	
2	4ES-85550-00	ROTOR ASSY	1	
3	98507-06016	SCREW, PAN HEAD	2	
4	92907-06600	WASHER, PLATE	2	
5	95317-10600	NUT	1	
6	90201-10774	WASHER, PLATE	1	
7	437-83936-01	BAND, SWITCH CORD	3	

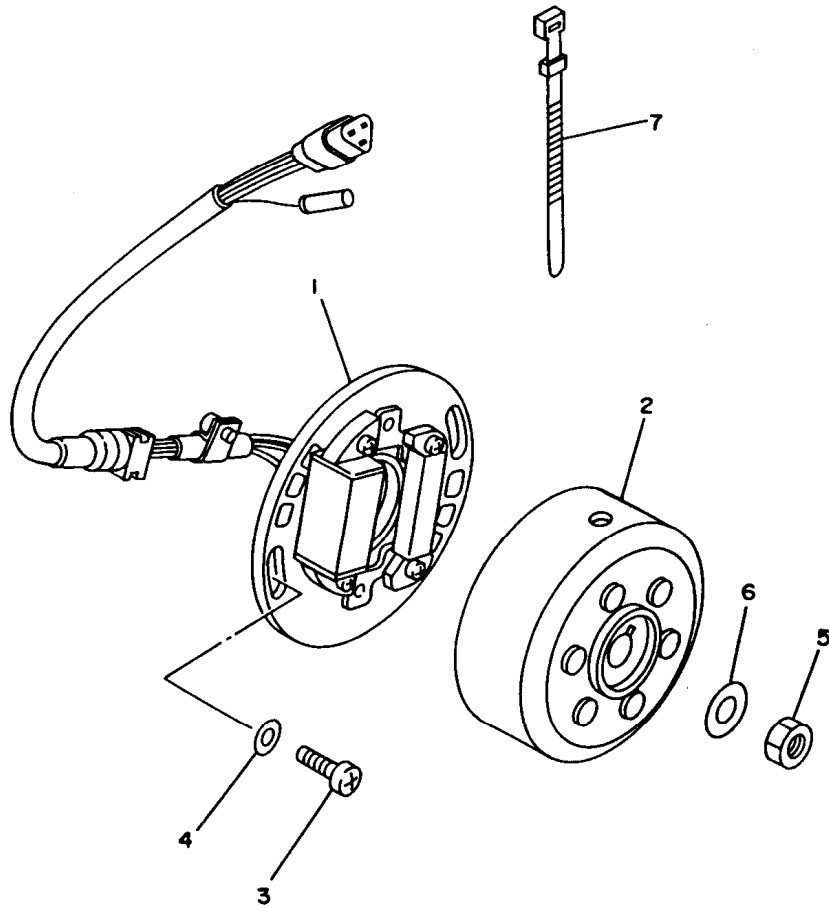

4GT3300-4320

D10

FIG. 33 HANDLE SWITCH. LEVER

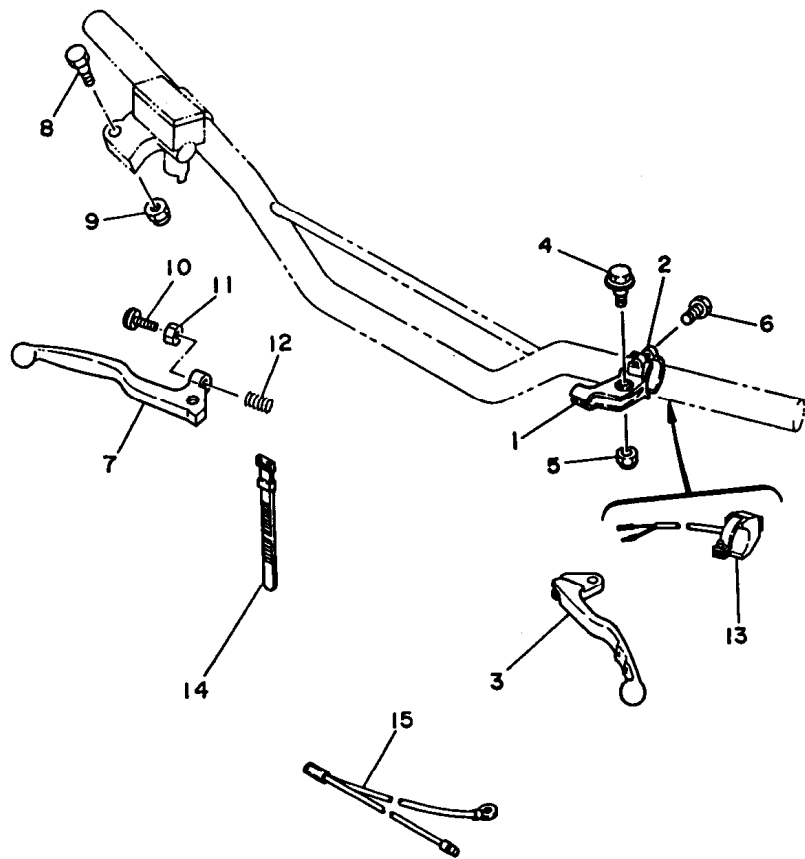

REF. NO.	PART NO.	DESCRIPTION	Q'TY	REMARKS
1	38V-82911-00	HOLDER, LEVER 1	1	
2	38V-82913-00	HOLDER, LEVER LOWER 1	1	
3	4GY-83912-00	LEVER 1	1	
4	90109-06799	BOLT	1	
5	95607-06100	NUT, U	1	
6	97007-05016	BOLT	2	
7	55Y-83922-00	LEVER 2	1	
8	90109-06577	BOLT	1	
9	95607-06100	NUT, U	1	
10	90143-06024	SCREW, HEXAGON	1	
11	90170-06010	NUT	1	
12	90501-061G2	SPRING, COMPRESSION	1	
13	23X-83976-00	SWITCH, HANDLE 1	1	
14	437-83936-01	BAND, SWITCH CORD	2	
15	5X1-82519-01	WIRE, EARTH LEAD	1	



4ES1100-3330

D11

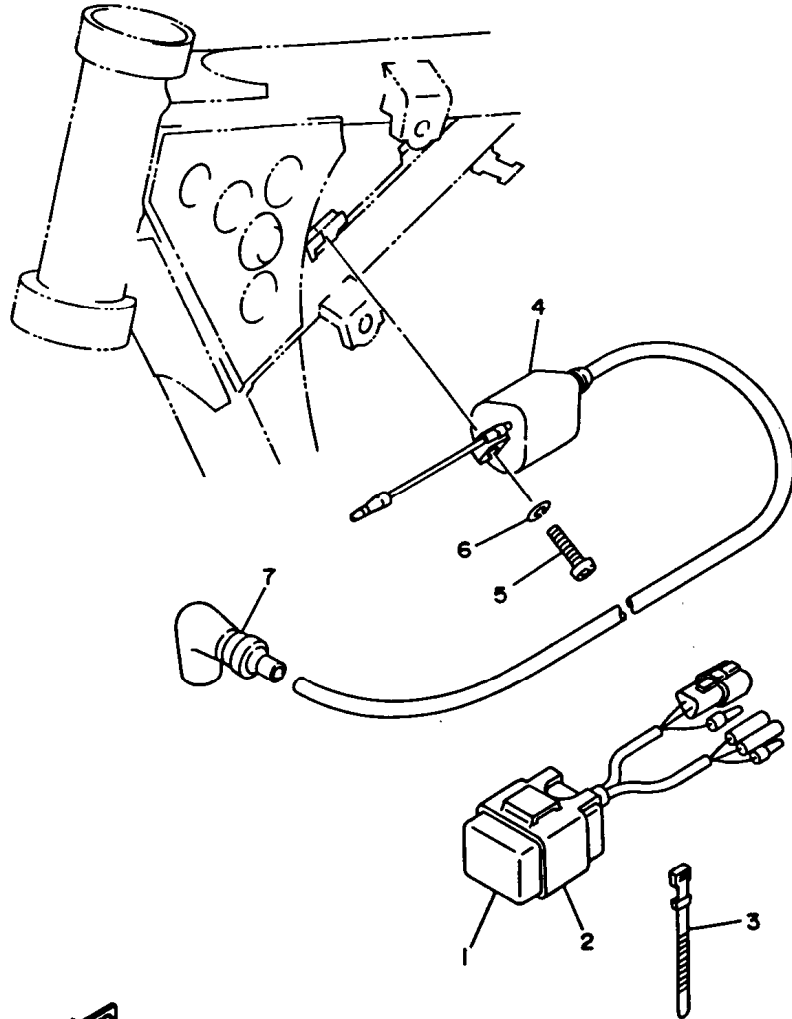

FIG. 34 ELECTRICAL 1

REF. NO.	PART NO.	DESCRIPTION	Q'TY	REMARKS
1	4ES-85540-10	C.D.I. UNIT ASSY	1	
2	2A7-85546-00	BAND	1	
3	437-83936-11	BAND, SWITCH CORD	1	
4	20N-82310-40	IGNITION COIL ASSY	1	
5	98507-06020	SCREW, PAN HEAD	2	
6	92907-06100	WASHER	2	
7	81E-82370-20	PLUG CAP ASSY	1	



4ES1100-3340

D12

FIG. 35 ALTERNATE (CHASSIS)

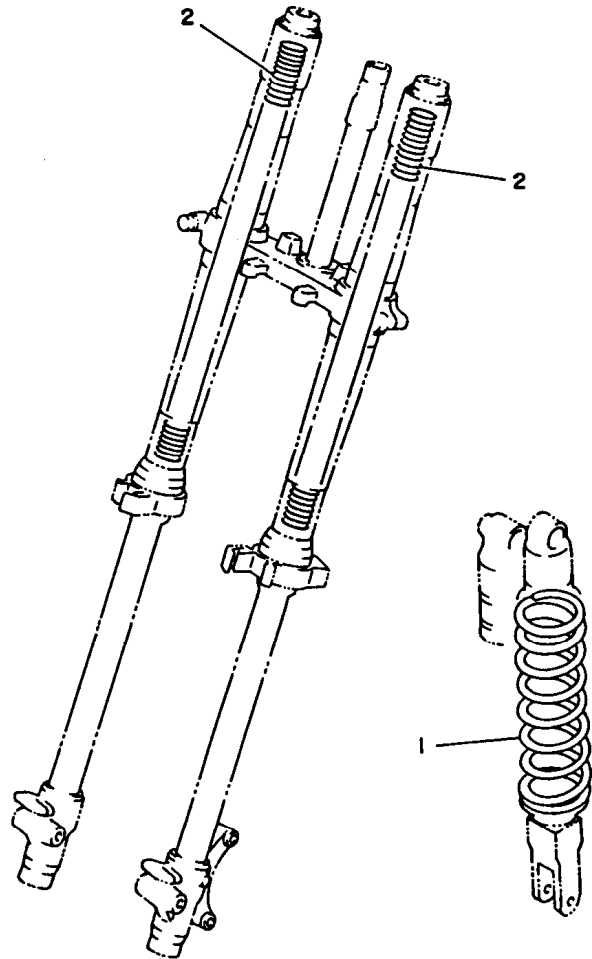

REF. NO.	PART NO.	DESCRIPTION	Q'TY	REMARKS
1	4ES-22212-80	SPRING (K=4.8)	1	AP (SOFT)
	4ES-22212-70	SPRING (K=5.0)	1	AP (SOFT) YZ80LW MODEL
	4ES-22212-90	SPRING (K=5.2)	1	AP (HARD)
	4ES-22212-A0	SPRING (K=5.4)	1	AP (HARD) YZ80LW MODEL
2	4ES-23141-10	SPRING, FRONT FORK (K=0.28)	2	AP (SOFT)
	4ES-23141-00	SPRING, FRONT FORK (K=0.29)	2	AP (SOFT) YZ80LW MODEL
	4ES-23141-20	SPRING, FRONT FORK (K=0.30)	2	AP (HARD)
	4ES-23141-30	SPRING, FRONT FORK (K=0.31)	2	AP (HARD) YZ80LW MODEL



4ES1100-3350

D13

FIG. 36 REPAIR KIT

REF. NO.	PART NO.	DESCRIPTION	Q'TY	REMARKS
1	4ES-11630-01	PISTON ASSY (STD)	1	
2	4ES-11631-01-80	.PISTON (STD)	1	
3	43K-11611-00	.RING, PISTON	1	
4	4ES-11633-00	.PIN, PISTON	1	
5	93450-16115	.CIRCLIP	2	
6	4ES-11650-01	CONNECTING ROD ASSY	1	
7	4ES-11651-01	.ROD, CONNECTING	1	
8	93310-320T3	.BEARING, CYLINDRICAL	1	
9	2RA-11681-00	.PIN, CRANK 1	1	
10	90209-20159	.WASHER	2	
11	93310-214F8	.BEARING, CYLINDRICAL	1	KOYO

D14

NUMERICAL INDEX

PART NO.	GRID NO.	PART NO.	GRID NO.	PART NO.	GRID NO.	PART NO.	GRID NO.	PART NO.	GRID NO.	PART NO.	GRID NO.
56A-W0041-00	D- 7	2X6-14112-25	B- 7	4ES-15641-00	B-12	4ES-21732-00	C- 6	4ES-23136-00	C-11	4ES-24161-20	C-13
1FK-W0042-50	D- 9	2X6-14112-30	B- 7	4ES-15651-00	B-12	4ES-21735-00	C- 6	4ES-2314F-00	C-12	22W-24181-00	C- 6
4ES-W0045-00	D- 2	2X6-14112-35	B- 7	4ES-15660-00	B-12	4DJ-2174A-00	C- 6	4ES-2314H-L1	C-12	3Y0-24183-00	C-13
4ES-W0046-50	D- 5	3R1-14115-00	B- 7	4ES-15664-00	B-12	4ES-21783-20	C- 6	4ES-2314J-L0	C-12	4ES-24311-10	C-13
1LR-W0047-00	D- 2	2A6-14126-00	B- 8	4ES-16111-00	B-13	4ES-22110-00	C- 7	4ES-23141-00	C-11	3XJ-24380-00	C-13
4ES-W0047-00	D- 5	248-14131-00	B- 7	4ES-16150-10	B-13	4LB-22110-00	C- 7		C-12	2VN-24500-01	C-13
36Y-W0048-00	D- 5	3R1-14141-50	B- 7	4VO-16154-00	B-13	4ES-22129-00	C- 7		D-13	4X8-24512-00	C-13
1LR-W0057-00	D- 2	3R1-14141-52	B- 7	21V-16321-00	B-13	4ES-22151-00	C- 7	4ES-23141-10	D-13	3AJ-24534-00	C-13
4ES-W0057-00	D- 5	3R1-14141-54	B- 7	4ES-16321-00	B-13	4ES-2217A-00	C- 7	4ES-23141-20	D-13	5X7-24611-01	C-13
4ES-11111-00	B- 2	260-14142-30	B- 7	131-16324-00	B-13	4ES-2217F-00	C- 8	4ES-23141-30	D-13	5X7-24612-00	C-13
4ES-11311-00	B- 2	260-14142-35	B- 7	257-16324-00	B-13	30X-22178-00	C- 4	4LB-23141-00	C-11	4ES-24728-00	C-14
4ES-11351-00	B- 2	260-14142-40	B- 7	2TK-16351-00	B-13	4ES-22178-00	C- 4		C-11	4ES-24731-10	C-14
4ES-11400-02	B- 3	137-14143-56-A0	B- 7	4ES-16356-00	B-13	4V4-22184-00	C- 4	4ES-23142-00	C-12	4ES-24770-10	C-14
4ES-11412-00	B- 3	137-14143-58-A1	B- 7	2RA-16357-00	B-13	39K-22199-00	C- 7		C-12	4ES-25104-20	C-15
4ES-11422-00	B- 3	137-14143-60-A0	B- 7	37F-16371-00	B-13	4ES-22201-30	C- 9	4V4-23142-L0	C-11	4LB-25104-00	C-15
43K-11611-00	B- 3	132-14146-00	B- 8	4ES-16381-00	B-13	4ES-22201-40	C- 9		C-12	4ES-25111-00	C-15
	D-14	39K-14153-00	B- 7	4ES-17121-00	B-14	4ES-22201-50	C- 9	4ES-23144-00	C-11	22W-25181-01	C- 7
4ES-11630-01	D-14	2A6-14158-00	B- 8	4ES-17131-00	B-14	4LB-22201-00	C- 9		C-12	4ES-25181-00	C-15
4ES-11631-01-A0	B- 3	3X3-14169-00	B- 8	4ES-17151-00	B-14	4ES-22210-60	C- 9	4ES-23145-00	C-11	4ES-25183-10	C-15
4ES-11631-01-B0	B- 3	3SB-14171-00	B- 8	4ES-17161-00	B-14	4ES-22210-70	C- 9		C-11	1T1-25194-00	C-15
	D-14	304-14184-00	B- 7	4ES-17211-01	B-14	4ES-22210-80	C- 9	5K5-23149-00	C-11	4ES-25304-20	D- 3
4ES-11631-01-C0	B- 3	314-14185-00	B- 7	4ES-17221-00	B-14	4LB-22210-20	C- 9		C-11	4LB-25304-00	D- 3
4ES-11631-01-D0	B- 3	127-14186-00	B- 7	4ES-17231-00	B-14	4ES-22212-A0	D-13	4A1-23156-00	C-11	4ES-25311-00	D- 3
4ES-11633-00	B- 3	55X-14196-00	B- 8	4ES-17241-00	B-14	4ES-22212-70	C- 9		C-12	4ES-25381-01	D- 3
	D-14	278-14197-00	B- 7	4ES-17251-00	B-14		D-13	2HH-23158-L0	C-11	4ES-25383-10	D- 3
4ES-11650-01	D-14	4ES-14411-01	B- 6	4ES-17261-00	B-14	4ES-22212-80	D-13		C-12	4ES-25383-00	D- 4
4ES-11651-01	B- 3	4ES-14417-00	B- 6	4ES-17411-00	B-14	4ES-22212-90	C- 9	4ES-2316A-10	C-11	4ES-25388-00	D- 3
	D-14	4ES-14451-00	B- 6	4ES-17421-00	B-14		D-13		C-12	1T2-25394-00	D- 3
2RA-11681-00	B- 3	4ES-14453-00	B- 6	164-17427-00-06	B-14	3JD-22214-00	C- 9	4ES-23170-10	C-11	5X2-25394-00	D- 3
	D-14	4ES-14458-00	B- 6	4ES-18101-00	C- 3	4ES-22214-00	C- 9		C-12	4ES-25446-00	D- 3
4BA-12422-00	B- 4	4ES-14459-00	B- 6	2HF-18110-01	C- 3	4ES-22216-00	C- 9	4ES-23171-00	C-11	4ES-25447-00	D- 3
4BA-12428-00	B- 4	4ES-14462-00	B- 6	4BA-18140-00	C- 3	4ES-22251-00	C- 9		C-11	4ES-25448-00	D- 3
36F-12450-00	B- 4	4ES-14610-00	B- 9	4ES-18511-00	C- 2	3XJ-22475-00	C- 8	58T-23184-L0	C- 9	4ES-25480-00	D- 2
4ES-12459-00	B- 4	17W-14615-00	B- 9	4VO-18512-00	C- 2	4ES-23102-10	C-11	4V4-23194-L0	C-12	4ES-2580T-00	D- 2
4ES-12461-00	B- 5	4ES-1469A-00	B- 9	4ES-18513-00	C- 2	4LB-23102-10	C-11	4ES-2331E-00	C-12	4ES-2580W-00	D- 5
22W-12462-00	B- 5	4ES-14753-00	B- 9	4BA-18531-00	C- 2	4ES-23103-10	C-11	4ES-23318-00	C-12	2VN-2582A-50	D- 9
22W-12463-00	B- 5	565-14771-00	B- 9	4BA-18535-00	C- 2	4LB-23103-10	C-11	4ES-23318-00	C-12	4ES-2582T-00	D- 2
4ES-12481-00	B- 5	58T-1490J-00	B- 7	4ES-18540-00	C- 2	4ES-23110-00	C-11	4ES-23340-00	C-12	4ES-2582W-00	D- 5
4ES-12482-00	B- 5	4ES-15111-00	B-10	4ES-21110-01-P1	C- 4	4ES-23110-00	C-11	4DA-23346-L0	C-12	47X-25824-00	D- 2
4ES-13565-00	B- 6	4ES-15121-01	B-10	4ES-21511-00	C- 5	4ES-23111-10	C-11	3XJ-23357-L0	C-11	51L-25825-00	D- 2
4ES-13610-00	B- 6	1RG-15363-00	B-11	4ES-21611-00	C- 5		C-12		C-12	3GD-25827-00	D- 5
4ES-13613-00	B- 6	583-15371-00	B-10	4ES-21642-00	C- 5	3JD-2312G-L0	C-11	4DA-23389-00	C-10	4ES-2583V-00	D- 9
4ES-13616-00	B- 6	4ES-15411-00	B-11	4ES-21711-00	C- 5		C-12	1J7-23415-00	C-10	34X-25845-00	D- 2
4ES-14101-01	B- 7	4ES-15421-01	B-11	4EW-2172A-00	C- 6	4ES-23120-00	C-11	4ES-23435-00	C-10	2VN-25852-01	D- 7
31J-14103-00	B- 7	4ES-15451-00	B-11	4ES-21721-00	C- 6	4ES-23125-00	C-11	3SP-23441-00	C-10	3XP-25852-50	D- 9
10W-14104-00	B- 8	4ES-15461-00	B-11	4ES-2173E-20	C- 6	4ES-23138-20	C-12	4ES-23485-00	C-10	2VN-25854-00	D- 9
22W-14106-00	B- 7	4ES-15620-00	B-12	4ES-2173F-20	C- 6	4ES-2313C-20	C-12	4ES-24110-00	C-13	56A-25854-00	D- 7
23L-14107-25	B- 7	4ES-15621-00	B-12	4ES-21731-00	C- 6	4ES-23136-00	C-11	4EW-2412F-00	C-13	2VN-25855-00	D- 9
								24X-24144-00	C-13	2VN-25866-00	D- 9

NUMERICAL INDEX

PART NO.	GRID NO.	PART NO.	GRID NO.	PART NO.	GRID NO.	PART NO.	GRID NO.	PART NO.	GRID NO.	PART NO.	GRID NO.
56A-25867-00	D- 7	437-83936-11	D-12	90183-06069	C- 6	90380-10218	C- 7	91401-16020	D- 9	93332-00079	C-10
2VM-25870-01	D- 7	23X-83976-00	D-11	90185-10120	C- 9	90380-12219	C- 7	91401-20030	D- 8	93399-99921	C- 8
4ES-25872-01	D- 7	4ES-85510-10	D-10	90185-12046	C-15	90381-12091	C- 8	91401-25020	D- 8	93410-20038	B-14
4LB-25872-01	D- 7	4ES-85540-10	D-12	90185-12119	C- 7	90385-17042	C- 7		D- 8	93430-08007	B-12
4ES-25873-01	D- 9	2A7-85546-00	D-12		C- 8	90387-06027	C-13	92902-04100	B- 7	93440-15012	B-14
4LB-25873-01	D- 9	4ES-85550-00	D-10	90201-047A2	B- 6	90387-062M9	C- 6	92907-03100	B- 6	93440-17064	B-14
2VM-25876-00	D- 9	9Y581-58117	D- 4	90201-060A3	B- 9	90387-062X0	C- 7	92907-04600	B- 6	93440-30113	C- 8
4EW-25894-00	D- 9	9Y581-58119	D- 4	90201-063J2	B- 5	90387-06216	C- 4	92907-06100	B- 6	93450-16115	B- 3
4ES-25895-00	D- 9	90101-08475	D- 4	90201-065F3	B-12	90387-063G3	B- 9		D-12		D-14
1UY-25919-51	D- 5	90101-12755	C- 8		B-14	90387-064X4	C- 5	92907-06200	C-14	93503-16010	B-13
56A-25919-00	D- 2	90105-08211	D- 2	90201-06697	C-13	90387-07006	B- 5	92907-06600	D-10	93507-32031	B-12
56A-25919-10	D- 2	90105-08310	C- 7	90201-08083	D- 9	90387-103X9	C- 8	92907-10600	C- 9	93603-22028	B- 4
4ES-25920-00	D- 5	90105-10582	C- 7	90201-08087	B- 2	90387-105L0	B- 9	93101-12060	C- 3	93822-12012	B-14
56A-25926-00	D- 2	90105-10614	C- 9		B-11	90387-1200U	C- 7	93101-17062	C- 7	93822-13024	B-14
3GD-25933-00	D- 5	90105-12382	C- 7	90201-081R9	C- 4	90387-124H0	C-15		C- 8	93822-14037	B-14
5R2-25937-00	D- 2	90109-06577	D-11	90201-08512	B- 4	90387-126Y7	C- 3	93102-12224	B-13	93822-15065	B-14
56A-25937-00	D- 2	90109-067F4	C- 6	90201-086P8	D- 3	90387-127J7	C- 7	93102-17263	B-12	94107-177Y5	C-15
4ES-26111-00	D- 6	90109-06799	D-11	90201-10118	D- 7	90387-127J8	C- 7	93102-20009	D- 3	94107-1906D	C-15
1LX-26241-01	D- 6	90109-081G2	D- 3		D- 9	90387-20488	B-13	93102-20143	B-14	94109-147Y6	D- 3
1LX-26242-01	D- 6	90109-08718	D- 5	90201-10119	D- 8	90387-22647	D- 6	93102-20447	B- 3	94109-1606E	D- 3
22W-26243-00	D- 6	90109-10729	C- 9		D- 8	90401-10159	D- 7	93103-10168	B- 4	94207-17284	C-15
5X2-2628H-01	D- 6	90110-08096	D- 5	90201-10774	D-10		D- 9	93103-28126	B- 3	94207-19290	C-15
5X2-26281-00	D- 6	90116-08318	B- 2	90201-12362	C-15	90430-06166	B- 4	93106-20031	C-15	94208-14285	D- 3
322-26282-00	D- 6	90116-08388	B- 2	90201-124F8	B-12	90445-09055	C-13	93109-17048	C- 7	94209-16291	D- 3
4ES-26311-00	D- 6	90116-08394	B- 2	90201-124G9	C- 7	90445-09100	C-13	93210-15620	D- 9	94307-16171	D- 3
4ES-26335-00	D- 6	90119-05001	B-13	90201-12631	B-12	90446-07349	B-10	93210-18288	B- 7	94307-17166	C-15
382-26372-01	D- 6	90119-06063	C- 5	90201-12749	C- 8	90450-28014	B- 5	93210-19123	B-11	94307-19170	C-15
56A-26372-01	D- 7	90119-06118	C- 4	90201-154E8	D- 8	90450-99064	B- 6	93210-371A9	B- 9	94308-14165	D- 3
4ES-27114-00	D- 5	90119-06185	C- 5	90201-161R1	D- 3	90460-43053	B- 6	93210-56459	B- 2	94414-17530	C-15
4ES-27211-00	D- 8	90119-06217	C- 6	90201-176L4	B-12	90460-51059	B- 6	93210-84724	B- 2	94414-19521	C-15
2YK-27222-00	D- 9		C- 6	90201-203E7	B-14	90467-08004	B- 5	93306-00210	D- 3	94416-14529	D- 3
4ES-27311-00	D- 8	90122-06034	B- 6	90201-256K5	C-10	90467-10008	C-13	93306-20117	C-15	94418-16522	D- 3
4LB-27311-00	D- 8	90123-08013	D- 6	90201-33299	B- 9	90467-11044	D- 9	93306-20204	D- 3	94681-58001	D- 4
3LD-27411-00	D- 8	90143-06024	D-11	90202-05193	C-13	90468-23194	B-12	93306-20333	B-14	94702-00367	B- 2
3LD-27421-00	D- 8	90149-06011	C-13	90208-12015	B-13	90480-15528	B- 5	93306-20421	B-14	94702-00368	B- 2
4ES-27491-00	D- 5	90149-06272	D- 2		B-13	90480-16561	B- 9	93306-20468	B- 3	95021-10040	C-12
3CV-28371-00	C- 5		D- 5	90209-06096	B- 6	90480-18411	B- 9	93306-30421	B- 3	95027-06012	B- 9
51L-28371-00	C-13	90157-06071	B-14	90209-06187	C- 5	90480-18549	C-13	93310-214F8	B- 3		B-12
20N-82310-40	D-12	90159-05122	C-10	90209-20159	B- 3	90501-061G2	D-11		D-14		C-10
81E-82370-20	D-12	90170-06010	D-11		D-14	90501-12081	B-12	93310-320T3	B- 3		C-14
5X1-82519-01	D-11	90176-08026	B- 2	90240-08124	D- 9	90501-20735	B-13		D-14		D- 5
38V-82911-00	D-11	90179-08148	D- 6	90240-10117	D- 8	90506-15480	D- 8	93315-11206	B-13		D- 9
38V-82913-00	D-11	90179-08491	B- 2		D- 8	90507-20030	B- 9	93315-31449	C- 7	95027-06014	C- 7
4GY-83912-00	D-11	90179-12244	B-13	90250-06013	C- 2	90508-242A6	C- 3	93315-31502	B-14	95027-06016	C- 5
55Y-83922-00	D-11		B-13	90267-40077	B- 6	90508-26750	B-12	93315-31748	C- 7		C- 6
437-83936-01	B- 5	90179-22412	B-13	90280-03017	B- 3	90508-28777	D- 8		C- 8		C-12
	D-10	90179-25033	C-10	90282-05001	B-13		D- 8	93317-11245	B-14		C-13
	D-11	90183-06023	C- 6	90338-10150	C- 8	90508-32553	C- 3	93317-21746	C- 7		D- 9

NUMERICAL INDEX

PART NO.	GRID NO.	PART NO.	GRID NO.	PART NO.	GRID NO.	PART NO.	GRID NO.	PART NO.	GRID NO.
95027-06020	B- 6	99009-18400	B-15						
	C-14	99009-35500	D- 3						
95027-06025	B- 4	99080-07600	B- 4						
	B- 9	99510-10114	B- 2						
	B- 9	99530-10014	B-10						
	D- 7		B-11						
95027-06030	B- 5								
	B-11								
	C-13								
95027-06040	B-11								
95027-08012	C- 4								
95027-08030	C-10								
95027-08080	B-11								
95307-08600	D- 9								
95307-08700	D- 4								
95317-10600	D-10								
95607-06100	D-11								
	D-11								
95607-08200	C- 4								
	C- 7								
95607-10200	C- 7								
95607-12200	C- 7								
95607-14200	D- 3								
95617-08100	D- 3								
95807-08035	C-10								
95817-08125	C- 4								
95817-08135	C- 4								
95827-06060	B- 4								
97007-05016	D-11								
97027-06020	C- 3								
97707-50014	B- 6								
97780-50110	D- 9								
98507-03008	B- 6								
98507-05016	D- 6								
98507-06016	D-10								
98507-06020	D-12								
98507-06030	B-11								
98507-06040	B-10								
98507-06050	B-10								
98507-06060	B-10								
98511-04016	B- 7								
98580-03008	C-13								
98706-04012	D- 7								
98707-04012	D- 6								
98707-06025	C-13								
99006-10600	C- 3								
99009-10400	C- 2								
99009-12400	B-12								