



PARTS CATALOGUE

YZ85D (1SN4) CANADA

YZ85 (1SN6) JAPAN

YZ85LW (1SP4) EUROPE

YZ85LW (1SP6) JAPAN

YZ85/YZ85LW
PARTS CATALOGUE
©2012 by Yamaha Motor Co., Ltd.
1st edition, July 2012
All rights reserved.
Any reprinting or unauthorized use
without the written permission of
Yamaha Motor Co., Ltd.
is expressly prohibited.
Printed in Japan.

FOREWORD

This Parts Catalogue is related to the parts for the model(s) on the cover page. When you are ordering replacement parts, please refer to this Parts Catalogue and quote both part numbers and part names correctly.

1. Modifications or additions which have been made after the issue of the Parts Catalogue will be announced in the Parts News.

It is advisable that you make the necessary corrections to the Parts Catalogue according to the Parts News.

2. Abbreviations

The following abbreviations are used in this Parts Catalogue.

“UR” Use specified parts number.

“UN” Use as many as needed.

“AP” Alternate Parts

“LM” Locally Made (Parts need to be ordered locally)

“F#” Frame No. (Applicable machine No.)

“O/S” Over Size

3. The number of components for assembly

- Parts, which are to be supplied in an assembly, are listed with a dot (.) in front of the part name as shown below.
- The numeral appearing to the right of each component part indicates the quantity of parts for each assembly unit.

PART NO.	DESCRIPTION	Q'TY	REMARKS
2F5-83310-60	FRONT FLASHER LIGHT ASSY	2	
115-83311-60	.BULB (6V-18W)	1	

4. Applicable colours of graphics are represented in the “REMARKS” as shown below.

PART NO.	DESCRIPTION	Q'TY	REMARKS
2N4-24110-00-X5	FUEL TANK COMP.	2	MXR
3J1-24240-10	.GRAPHIC, FUEL TANK	1	FOR MXR

5. Note that the illustrations for reference in finding parts numbers are not to be used for assembling. When assembling, please use the applicable service manual.

6. The asterisk (*) before a reference number indicates modified items after the first edition.

CONTENTS

ENGINE

CYLINDER	1
CRANKSHAFT & PISTON	2
WATER PUMP	3
RADIATOR & HOSE	4
INTAKE	5
CARBURETOR	6
EXHAUST	8
CRANKCASE	9
CRANKCASE COVER 1	10
STARTER	11
CLUTCH	12
TRANSMISSION	13
SHIFT CAM & FORK	15
SHIFT SHAFT	16

CHASSIS

FRAME	17
FENDER	18
SIDE COVER	19
REAR ARM	20
REAR SUSPENSION	22
STEERING	23
FRONT FORK	24
FUEL TANK	27
SEAT	28
FRONT WHEEL	29
FRONT BRAKE CALIPER	30
REAR WHEEL	31
REAR BRAKE CALIPER	33
STEERING HANDLE & CABLE	34
FRONT MASTER CYLINDER	35
STAND & FOOTREST	36
REAR MASTER CYLINDER	37
GENERATOR	38
HANDLE SWITCH & LEVER	39
ELECTRICAL 1	40
ALTERNATE FOR CHASSIS	41
OPTIONAL PARTS 1	42

INDEX

NUMERICAL INDEX	43
-----------------------	----

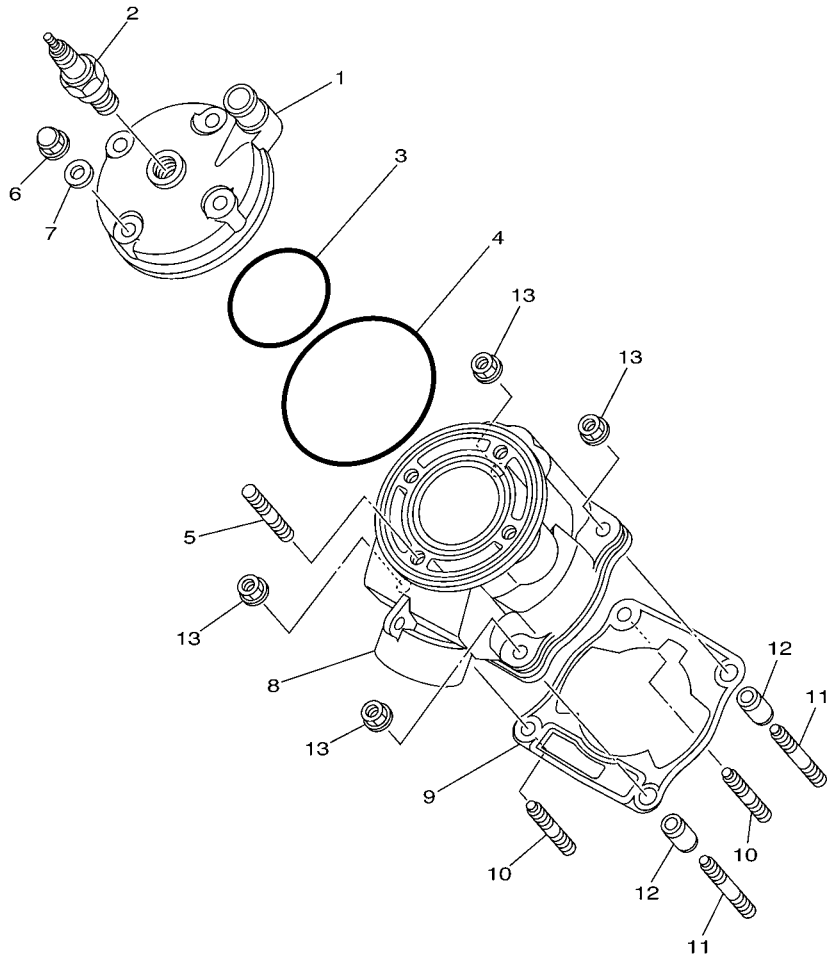

5PA1100-A010

FIG. 1 CYLINDER

REF. NO.	PART NO.	DESCRIPTION	1SN4	1SN6	1SP4	1SP6	REMARKS
1	5PA-11111-00	HEAD, CYLINDER 1	1	1	1	1	
2	94702-00368	PLUG, SPARK (NGK BR10EG)	1	1			
	94709-00368	PLUG, SPARK (NGK BR10EG)		1	1		
3	93210-56459	O-RING	1	1	1	1	
4	93210-84724	O-RING	1	1	1	1	
5	90116-08027	BOLT, STUD	4	4	4	4	
6	90176-08005	NUT, CROWN	4	4	4	4	
7	90201-080L8	WASHER, PLATE	4	4	4	4	
8	5PA-11311-20	CYLINDER 1	1	1	1	1	
9	4ES-11351-00	GASKET, CYLINDER	1	1	1	1	
10	90116-08031	BOLT, STUD	2	2	2	2	
11	90116-08028	BOLT, STUD	2	2	2	2	
12	99590-10114	PIN, DOWEL	2	2	2	2	
13	90179-08019	NUT	4	4	4	4	

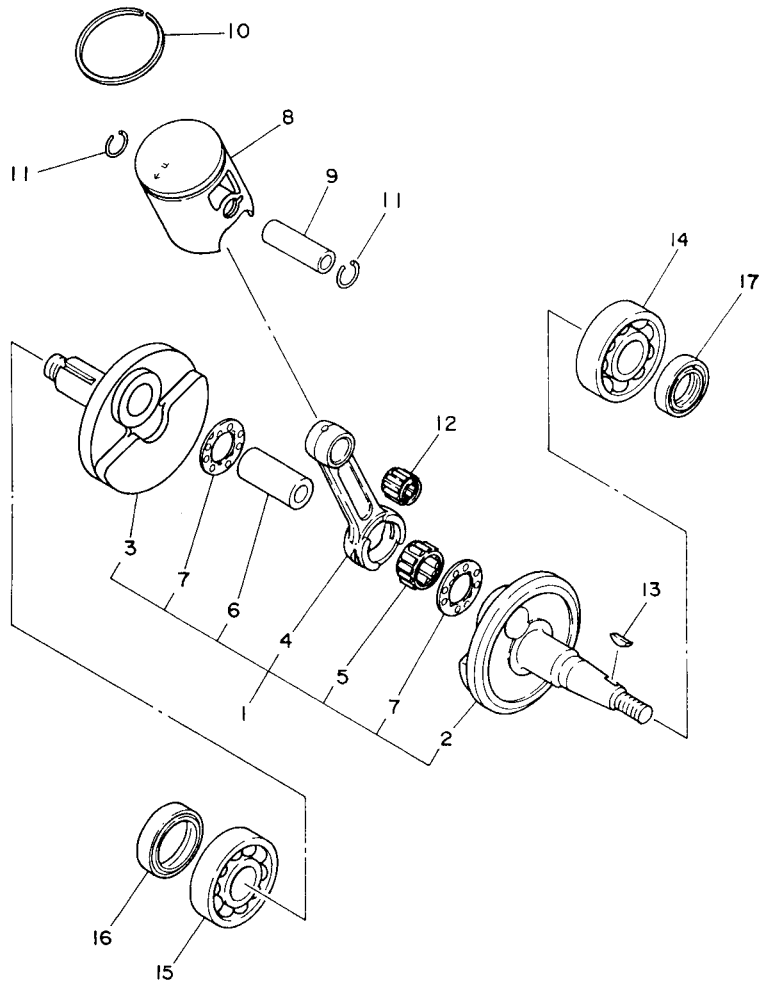

4ES1100-3020

FIG. 2 CRANKSHAFT & PISTON

REF. NO.	PART NO.	DESCRIPTION	1SN4	1SN6	1SP4	1SP6	REMARKS
1	5PA-11400-00	CRANKSHAFT ASSY	1	1	1	1	
2	5PA-11412-00	.CRANK 1	1	1	1	1	
3	5PA-11422-00	.CRANK 2	1	1	1	1	
4	4ES-11651-10	.ROD, CONNECTING	1	1	1	1	
5	93310-420B1	.BEARING	1	1	1	1	
6	2RA-11681-00	.PIN, CRANK 1	1	1	1	1	
7	90209-20159	.WASHER	2	2	2	2	
8	5PA-11631-00-A0	PISTON (STD)	1	1	1	1	UR RED
	5PA-11631-00-B0	PISTON (STD)	1	1	1	1	UR ORANGE
	5PA-11631-00-C0	PISTON (STD)	1	1	1	1	UR GREEN
	5PA-11631-00-D0	PISTON (STD)	1	1	1	1	UR PURPLE
9	4ES-11633-00	PIN, PISTON	1	1	1	1	
10	5PA-11611-00	RING, PISTON	1	1	1	1	
11	93450-16115	CIRCLIP	2	2	2	2	
12	93310-21417	BEARING	1	1	1	1	
13	90280-03045	KEY, WOODRUFF	1	1	1	1	
14	93306-20438	BEARING	1	1	1	1	
15	93306-30421	BEARING	1	1	1	1	
16	93102-28009	OIL SEAL	1	1	1	1	
17	93102-20447	OIL SEAL	1	1	1	1	

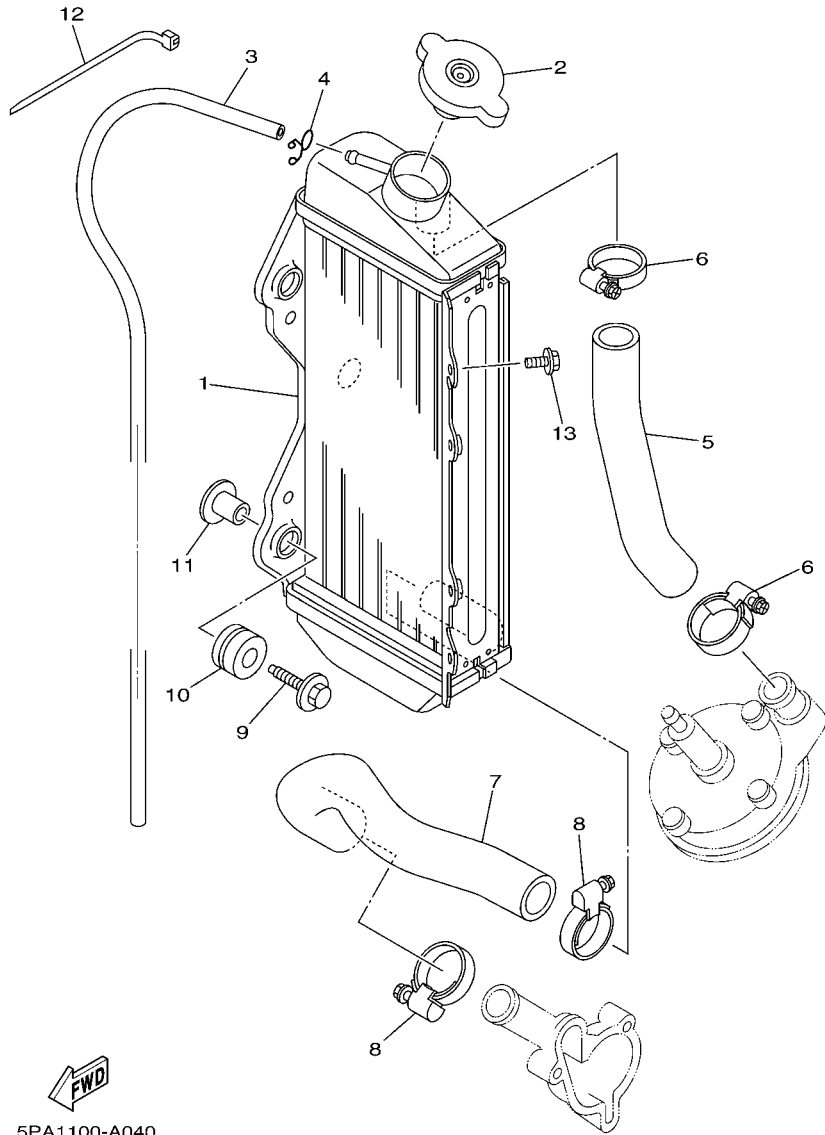

5PA1100-A040

FIG. 4 RADIATOR & HOSE

REF. NO.	PART NO.	DESCRIPTION	1SN4	1SN6	1SP4	1SP6	REMARKS
1	5PA-12461-00	RADIATOR COMP	1	1	1	1	
2	22W-12462-00	CAP, RADIATOR	1	1	1	1	
3	22W-12463-00	PIPE, BREATHER	1	1	1	1	
4	90467-08002	CLIP	1	1	1	1	
5	4ES-12481-10	PIPE 1	1	1	1	1	
6	90450-25037	HOSE CLAMP ASSY	2	2	2	2	
7	5PA-12482-00	PIPE 2	1	1	1	1	
8	90450-28014	HOSE CLAMP ASSY	2	2	2	2	
9	90119-06181	BOLT, WITH WASHER	3	3	3	3	
10	90480-15528	GROMMET	3	3	3	3	
11	90387-0614M	COLLAR	3	3	3	3	
12	90464-13077	CLAMP	2	2	2	2	
13	95822-06010	BOLT, FLANGE	1	1	1	1	

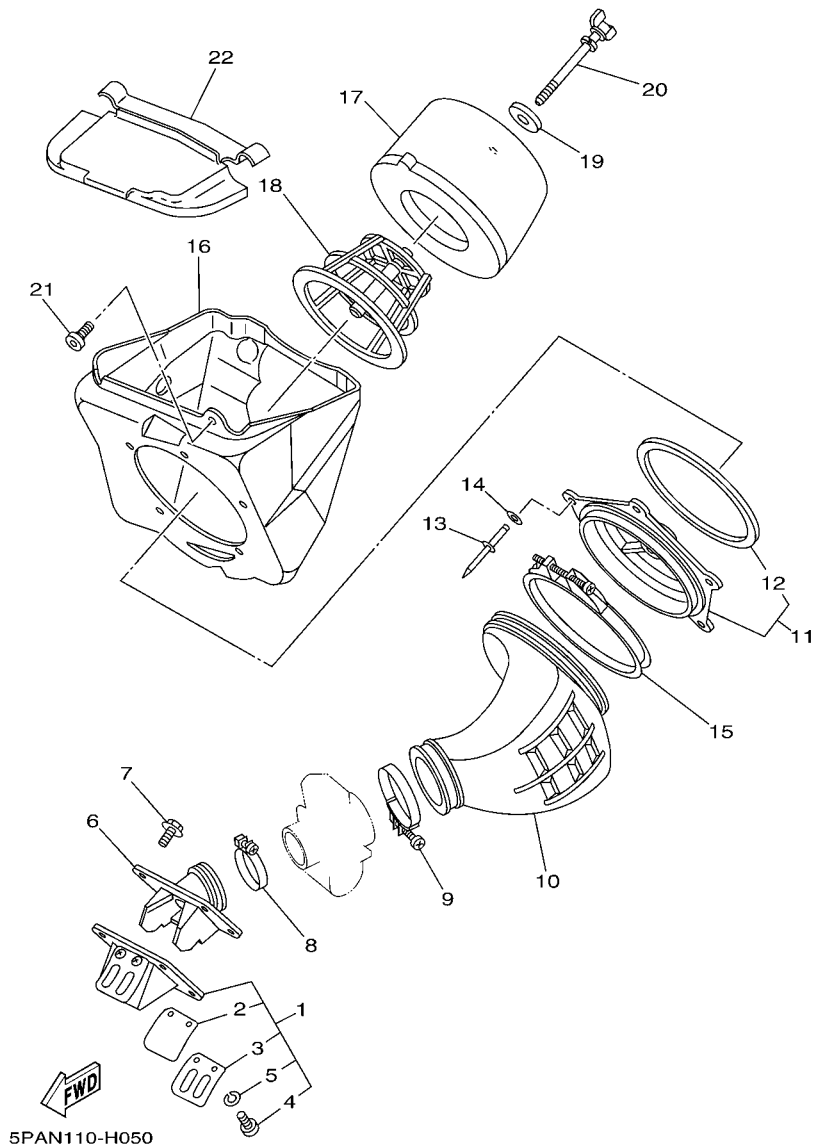

FIG. 5 INTAKE

REF. NO.	PART NO.	DESCRIPTION	1SN4	1SN6	1SP4	1SP6	REMARKS
1	4ES-13610-00	REED VALVE ASSY	1	1	1	1	
2	4ES-13613-00	.REED, VALVE	2	2	2	2	
3	4ES-13616-00	.STOPPER, REED VALVE	2	2	2	2	
4	98502-03006	.SCREW, PAN HEAD	4	4	4	4	
5	92902-03100	.WASHER	4	4	4	4	
6	5PA-13565-00	JOINT, CARBURETOR	1	1	1	1	
7	95022-06020	BOLT, FLANGE	4	4	4	4	
8	90450-41001	HOSE CLAMP ASSY	1	1	1	1	
9	90460-56071	CLAMP, HOSE	1	1	1	1	
10	5PA-14453-00	JOINT, AIR CLEANER 1	1	1	1	1	
11	5PA-14459-00	HOLDER, GUIDE	1	1	1	1	
12	4ES-14462-00	.SEAL	1	1	1	1	
13	90267-48138	RIVET, BLIND	5	5	5	5	
14	90201-043H7	WASHER, PLATE	5	5	5	5	
15	90450-99064	HOSE CLAMP ASSY	1	1	1	1	
16	5PA-14411-10	CASE, AIR CLEANER 1	1	1	1	1	
17	5PA-14451-00	ELEMENT, AIR CLEANER	1	1	1	1	
18	5PA-14458-00	GUIDE	1	1	1	1	
19	90209-06096	WASHER	1	1	1	1	
20	90122-06010	BOLT, WING	1	1	1	1	
21	90109-065F3	BOLT	1	1	1	1	
22	5PA-14417-00	COVER 1	1	1	1	1	AP

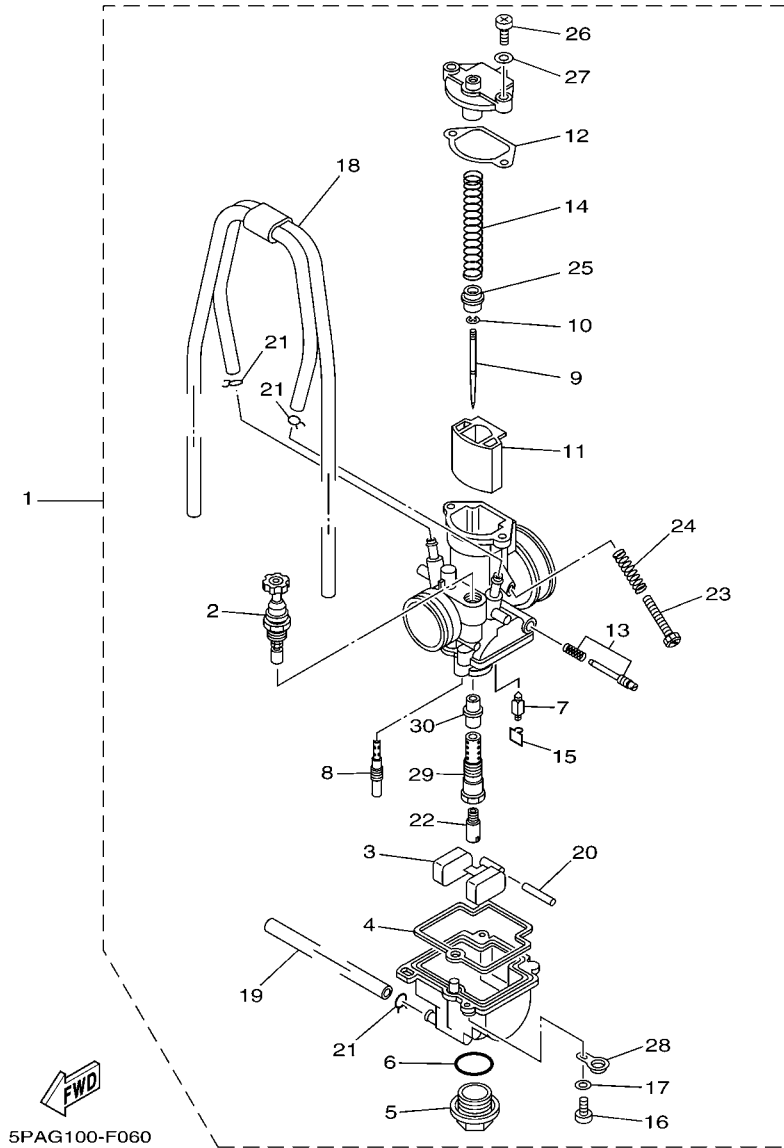
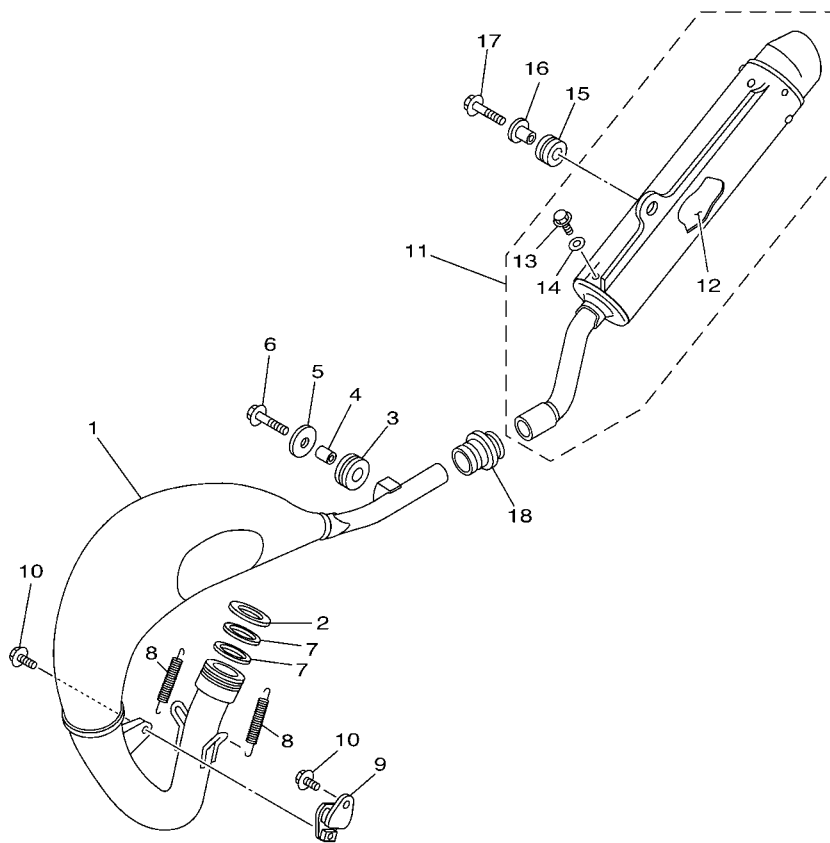

FIG. 6 CARBURETOR

REF. NO.	PART NO.	DESCRIPTION	1SN4	1SN6	1SP4	1SP6	REMARKS
1	5PA-14101-00	CARBURETOR ASSY 1	1	1	1	1	
2	4JT-14171-00	.PLUNGER, STARTER	1	1	1	1	
3	5PA-14985-00	.FLOAT	1	1	1	1	
4	5PA-14984-00	.GASKET, FLOAT CHAMBER	1	1	1	1	
5	4MX-14115-00	.PLUG, SCREW	1	1	1	1	
6	4MX-14561-00	.O-RING	1	1	1	1	
7	5PA-14392-00	.VALVE, NEEDLE	1	1	1	1	
8	4MX-14948-05	.JET, SLOW (#45)	1	1	1	1	STD
	4MX-14948-04	.JET, SLOW (#42)	1	1	1	1	AP
	4MX-14948-06	.JET, SLOW (#48)	1	1	1	1	AP
9	5PA-14916-KF	.NEEDLE (NBKF)	1	1	1	1	STD
	5PA-14916-KE	.NEEDLE (NBKE)	1	1	1	1	AP
	5PA-14916-KG	.NEEDLE (NBKG)	1	1	1	1	AP
	5PA-14916-LE	.NEEDLE (NBLE)	1	1	1	1	AP
	5PA-14916-LF	.NEEDLE (NBLE)	1	1	1	1	AP
	5PA-14916-LG	.NEEDLE (NBLE)	1	1	1	1	AP
10	4MX-14919-00	.CLIP	1	1	1	1	
11	5PA-14340-00	.VALVE ASSY	1	1	1	1	
12	5PA-14126-00	.GASKET	1	1	1	1	
13	5PA-14105-00	.PILOT SCREW SET	1	1	1	1	
14	5PA-14131-00	.SPRING, THROTTLE VALVE	1	1	1	1	
15	5PA-14159-00	.CLIP	1	1	1	1	
16	98504-04014	.SCREW, PAN HEAD	2	2	2	2	
17	92903-04600	.WASHER	2	2	2	2	
18	5PA-1410E-00	.HOSE	1	1	1	1	
19	4XL-14197-10	.PIPE	1	1	1	1	
20	676-14548-00	.PIN, FLOAT ARM	1	1	1	1	

FIG. 7 EXHAUST



REF. NO.	PART NO.	DESCRIPTION	1SN4	1SN6	1SP4	1SP6	REMARKS
1	5PA-14610-00	EXHAUST PIPE ASSY 1	1	1	1	1	
2	90201-33299	WASHER, PLATE	1	1	1	1	
3	90480-18411	GROMMET	1	1	1	1	
4	90387-105L0	COLLAR	1	1	1	1	
5	90201-06086	WASHER, PLATE	1	1	1	1	
6	95022-06025	BOLT, FLANGE	1	1	1	1	
7	5PA-14642-00	SEAL, EXHAUST	2	2	2	2	
8	90507-20052	SPRING, TENSION	2	2	2	2	
9	565-14771-00	STAY, MUFFLER 1	1	1	1	1	
10	90119-06217	BOLT, WITH WASHER	2	2	2	2	
11	4ES-14753-20	SILENCER, EXHAUST	1	1	1	1	
12	4ES-1469A-00	.FIBER	1	1	1	1	
13	92012-06010	.BOLT, BUTTON HEAD	2	2	2	2	
14	90201-06089	.WASHER, PLATE	2	2	2	2	
15	90480-16561	GROMMET	1	1	1	1	
16	90387-06168	COLLAR	1	1	1	1	
17	95022-06025	BOLT, FLANGE	1	1	1	1	
18	17W-14615-00	JOINT, EXHAUST 1	1	1	1	1	



5PA4100-B070

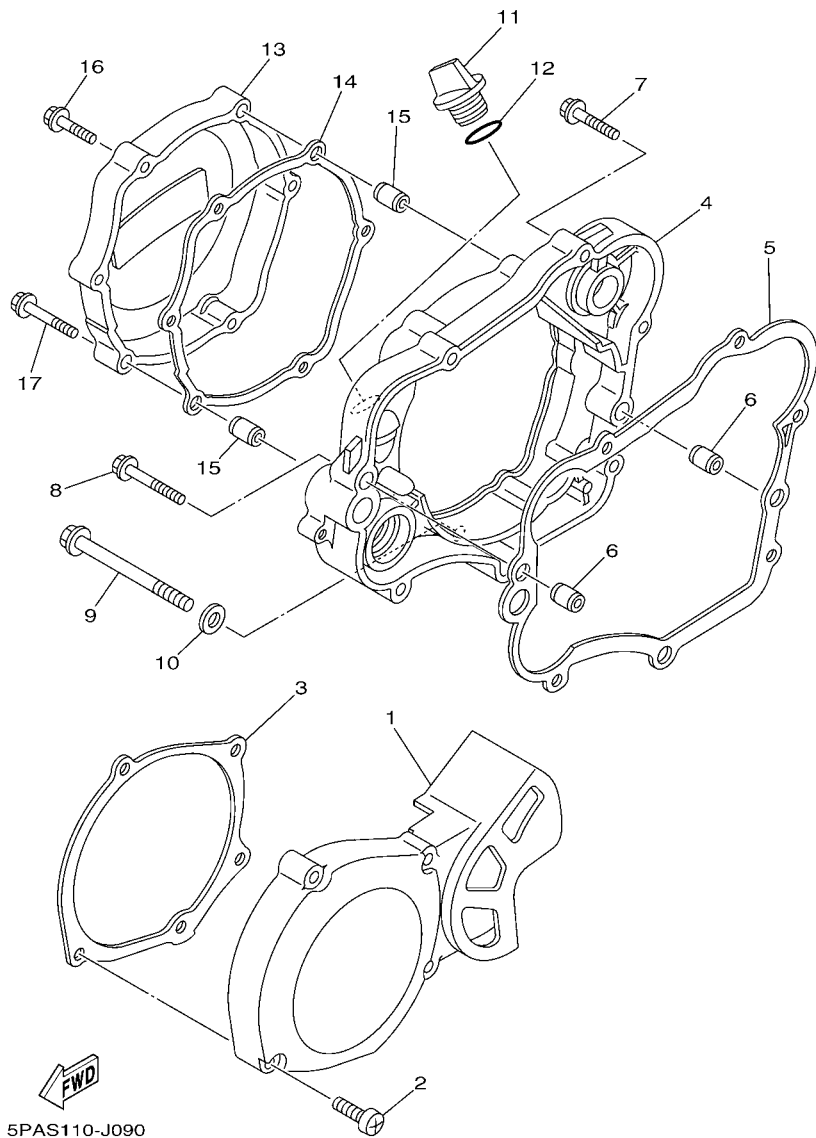
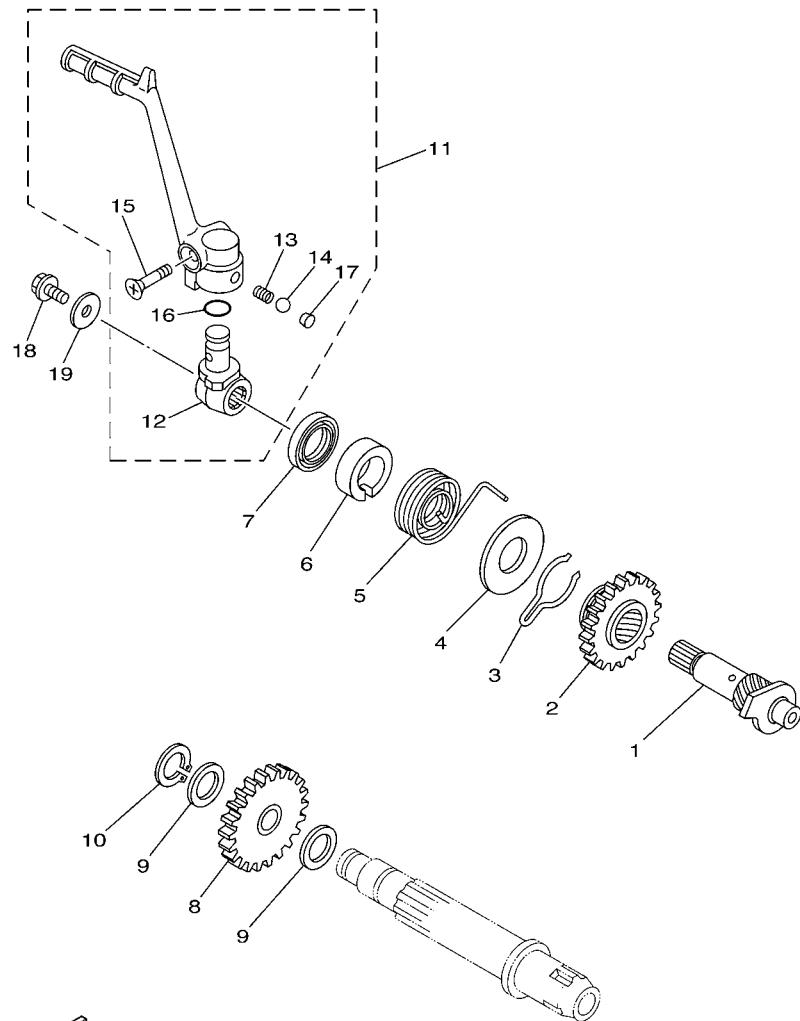

FIG. 9 CRANKCASE COVER 1

REF. NO.	PART NO.	DESCRIPTION	1SN4	1SN6	1SP4	1SP6	REMARKS
1	4ES-15411-00	COVER, CRANKCASE 1	1	1	1	1	
2	98502-06030	SCREW, PAN HEAD	4	4	4	4	
3	5PA-15451-00	GASKET, CRANKCASE COVER 1	1	1	1	1	
4	5PA-15431-00	COVER, CRANKCASE 3	1	1	1	1	
5	4ES-15461-00	GASKET, CRANKCASE COVER 2	1	1	1	1	
6	99530-10014	PIN, DOWEL	2	2	2	2	
7	95022-06030	BOLT, FLANGE	4	4	4	4	
8	95022-06040	BOLT, FLANGE	1	1	1	1	
9	95022-08080	BOLT, FLANGE	1	1	1	1	
10	90430-08119	GASKET	1	1	1	1	
11	3Y1-15363-10	PLUG, OIL	1	1	1	1	
12	93210-19123	O-RING	1	1	1	1	
13	5PA-15415-10	COVER, GENERATOR	1	1	1	1	
14	5PA-15463-00	GASKET, COVER PINION 2	1	1	1	1	
15	99530-08016	PIN, DOWEL	2	2	2	2	
16	95022-06025	BOLT, FLANGE	4	4	4	4	
17	95022-06035	BOLT, FLANGE	2	2	2	2	



5PA1100-A100

FIG. 10 STARTER

REF. NO.	PART NO.	DESCRIPTION	1SN4	1SN6	1SP4	1SP6	REMARKS
1	5PA-15660-00	KICK AXLE ASSY	1	1	1	1	
2	5PA-15641-00	GEAR, KICK	1	1	1	1	
3	90468-23194	CLIP	1	1	1	1	
4	90201-176L4	WASHER, PLATE	1	1	1	1	
5	90508-26750	SPRING, TORSION	1	1	1	1	
6	4ES-15664-00	GUIDE, SPRING	1	1	1	1	
7	93102-17263	OIL SEAL	1	1	1	1	
8	5PA-15651-00	GEAR, KICK IDLE	1	1	1	1	
9	90201-124F8	WASHER, PLATE	2	2	2	2	
10	99009-12400	CIRCLIP	1	1	1	1	
11	5PA-15620-01	KICK CRANK ASSY	1	1	1	1	
12	5PA-15621-00	.BOSS, KICK CRANK	1	1	1	1	
13	90501-12081	.SPRING, COMPRESSION	1	1	1	1	
14	93507-32009	.BALL	1	1	1	1	
15	90151-06045	.SCREW, COUNTERSUNK	1	1	1	1	
16	93210-12152	.O-RING	1	1	1	1	
17	90336-06031	.PLUG, TAPER	1	1	1	1	
18	95022-06012	BOLT, FLANGE	1	1	1	1	
19	90201-06060	WASHER, PLATE	1	1	1	1	

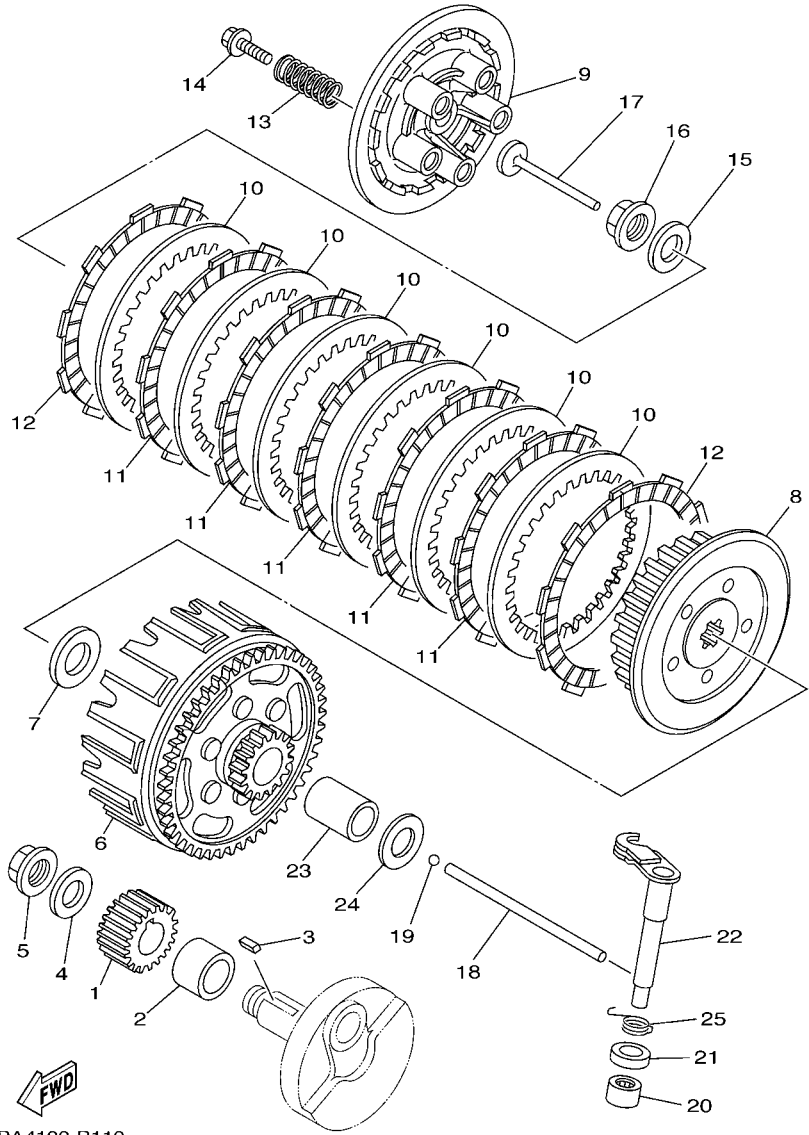

5PA4100-B110

FIG. 11 CLUTCH

REF. NO.	PART NO.	DESCRIPTION	1SN4	1SN6	1SP4	1SP6	REMARKS
1	5PA-16111-00	GEAR, PRIMARY DRIVE	1	1	1	1	
2	90387-20488	COLLAR	1	1	1	1	
3	90282-05001	KEY, STRAIGHT (5MMX16MM)	1	1	1	1	
4	90208-12015	WASHER, CONICAL SPRING	1	1	1	1	
5	90179-12007	NUT	1	1	1	1	
6	5PA-16150-10	PRIMARY DRIVEN GEAR COMP.	1	1	1	1	
7	90201-17558	WASHER, PLATE	1	1	1	1	
8	5PA-16371-10	BOSS, CLUTCH	1	1	1	1	
9	2TK-16351-00	PLATE, PRESSURE 1	1	1	1	1	
10	131-16324-00	PLATE, CLUTCH 1	6	6	6	6	
11	4ES-16321-00	PLATE, FRICTION	5	5	5	5	
12	21V-16321-00	PLATE, FRICTION	2	2	2	2	
13	90501-204A0	SPRING, COMPRESSION	5	5	5	5	
14	90119-05001	BOLT, WITH WASHER	5	5	5	5	
15	90208-12015	WASHER, CONICAL SPRING	1	1	1	1	
16	90179-12007	NUT	1	1	1	1	
17	4ES-16356-00	ROD, PUSH 1	1	1	1	1	
18	5PA-16357-00	ROD, PUSH 2	1	1	1	1	
19	93503-16003	BALL	1	1	1	1	
20	93315-11206	BEARING	1	1	1	1	
21	93102-12224	OIL SEAL	1	1	1	1	
22	4ES-16381-00	PUSH LEVER COMP.	1	1	1	1	
23	5PA-16181-00	SPACER 1	1	1	1	1	
24	90201-171G6	WASHER, PLATE	1	1	1	1	
25	90508-14016	SPRING, TORSION	1	1	1	1	

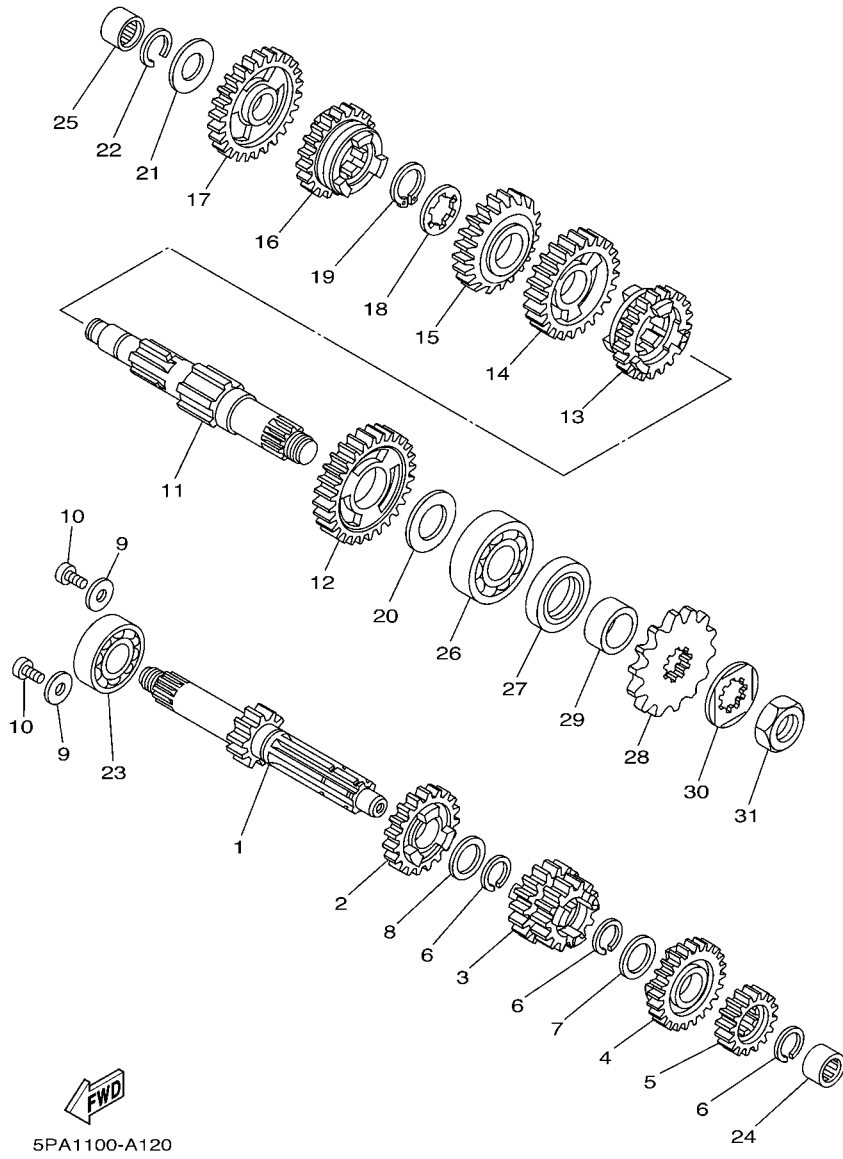

FIG. 12 TRANSMISSION

REF. NO.	PART NO.	DESCRIPTION	1SN4	1SN6	1SP4	1SP6	REMARKS
1	5PA-17411-00	AXLE, MAIN (11T)	1	1	1	1	
2	4ES-17151-10	GEAR, 5TH PINION (23T)	1	1	1	1	
3	4ES-17131-03	GEAR, 3RD PINION (17T/17T)	1	1	1	1	
4	4ES-17161-10	GEAR, 6TH PINION (25T)	1	1	1	1	
5	4ES-17121-01	GEAR, 2ND PINION (17T)	1	1	1	1	
6	93440-17064	CIRCLIP	3	3	3	3	
7	90209-14008	WASHER	1	1	1	1	
8	90201-17545	WASHER, PLATE	1	1	1	1	
9	90201-06060	WASHER, PLATE	2	2	2	2	
10	90157-06008	SCREW, PAN HEAD	2	2	2	2	
11	5PA-17421-00	AXLE, DRIVE	1	1	1	1	
12	5PA-17221-00	GEAR, 2ND WHEEL (32T)	1	1	1	1	
13	5PA-17261-01	GEAR, 6TH WHEEL (25T)	1	1	1	1	
14	4ES-17231-10	GEAR, 3RD WHEEL (26T)	1	1	1	1	
15	5PA-17241-00	GEAR, 4TH WHEEL (22T)	1	1	1	1	
16	4ES-17251-00	GEAR, 5TH WHEEL (26T)	1	1	1	1	
17	4ES-17211-01	GEAR, 1ST WHEEL (27T)	1	1	1	1	
18	90209-16209	WASHER	1	1	1	1	
19	93410-20038	CIRCLIP	1	1	1	1	
20	90201-20611	WASHER, PLATE	1	1	1	1	
21	164-17427-00-06	SHIM 1 (T=0.6)	1	1	1	1	UR
	164-17427-00-08	SHIM 1 (T=0.8)	1	1	1	1	UR
	164-17427-00-10	SHIM 1 (T=1.0)	1	1	1	1	UR
22	93440-15012	CIRCLIP	1	1	1	1	
23	93306-20333	BEARING	1	1	1	1	
24	93317-11245	BEARING	1	1	1	1	
25	93315-31502	BEARING	1	1	1	1	

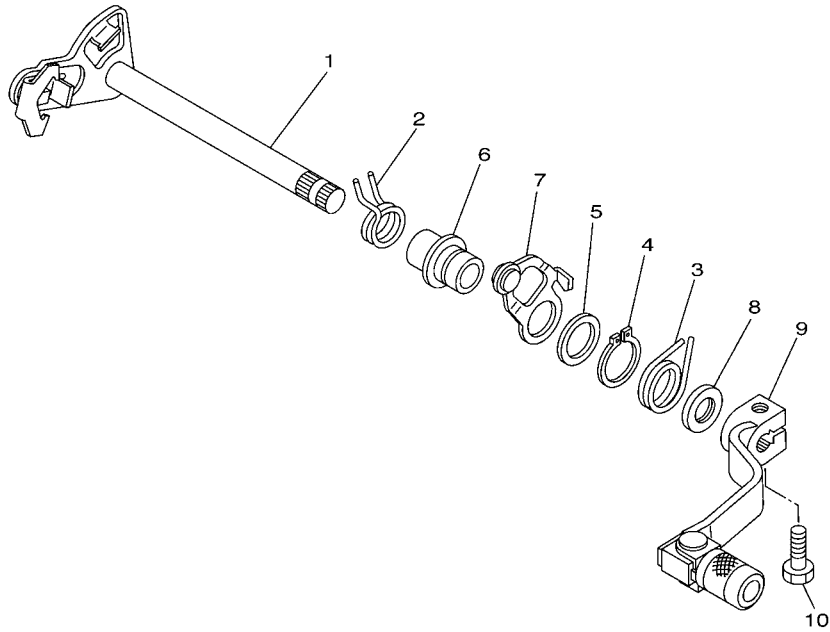

FIG. 14 SHIFT SHAFT

REF. NO.	PART NO.	DESCRIPTION	1SN4	1SN6	1SP4	1SP6	REMARKS
1	5PA-18101-00	SHIFT SHAFT ASSY	1	1	1	1	
2	90508-32016	SPRING, TORSION	1	1	1	1	
3	90508-24007	SPRING, TORSION	1	1	1	1	
4	99009-17400	CIRCLIP	1	1	1	1	
5	90201-177G4	WASHER, PLATE	1	1	1	1	
6	5PA-1811E-00	COLLAR,SHIFT PEDAL	1	1	1	1	
7	5PA-18140-00	STOPPER LEVER ASSY	1	1	1	1	
8	93101-12173	OIL SEAL	1	1	1	1	
9	2HF-18110-02	SHIFT PEDAL ASSY	1	1	1	1	
10	97022-06020	BOLT	1	1	1	1	



5PA1100-A140

FIG. 15 FRAME

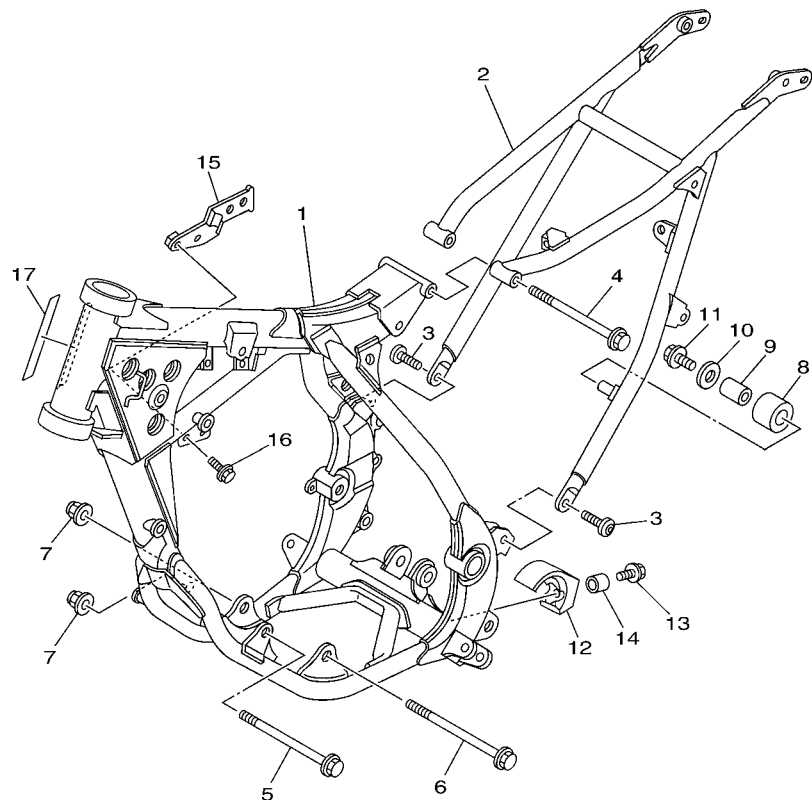

REF. NO.	PART NO.	DESCRIPTION	1SN4	1SN6	1SP4	1SP6	REMARKS
1	5PA-21101-12-33	FRONT FRAME COMP.	1	1	1	1	YB FOR DPBSE
2	5PA-21190-00-33	REAR FRAME COMP.	1	1	1	1	YB FOR DPBSE
3	90111-08029	BOLT,HEX. SOCKET BUTTON	2	2	2	2	
4	95812-08125	BOLT, FLANGE	1	1	1	1	
5	90105-10220	BOLT, FLANGE	1	1	1	1	
6	90105-10219	BOLT, FLANGE	1	1	1	1	
7	95602-10200	NUT, U FLANGE	2	2	2	2	
8	30X-22178-00	TENSIONER	1	1	1	1	
9	4V4-22184-00	BUSH	1	1	1	1	
10	90201-08078	WASHER, PLATE	1	1	1	1	
11	95022-08012	BOLT, FLANGE	1	1	1	1	
12	4ES-22178-00	TENSIONER	1	1	1	1	
13	90119-06159	BOLT, WITH WASHER	1	1	1	1	
14	90387-067K6	COLLAR	1	1	1	1	
15	5PA-21274-10	BRACKET, C.D.I. UNIT	1	1	1	1	
16	95022-06012	BOLT, FLANGE	2	2	2	2	
17	3HA-24141-00	PROTECTOR, FUEL TANK	1	1	1	1	



5PAK100-G150

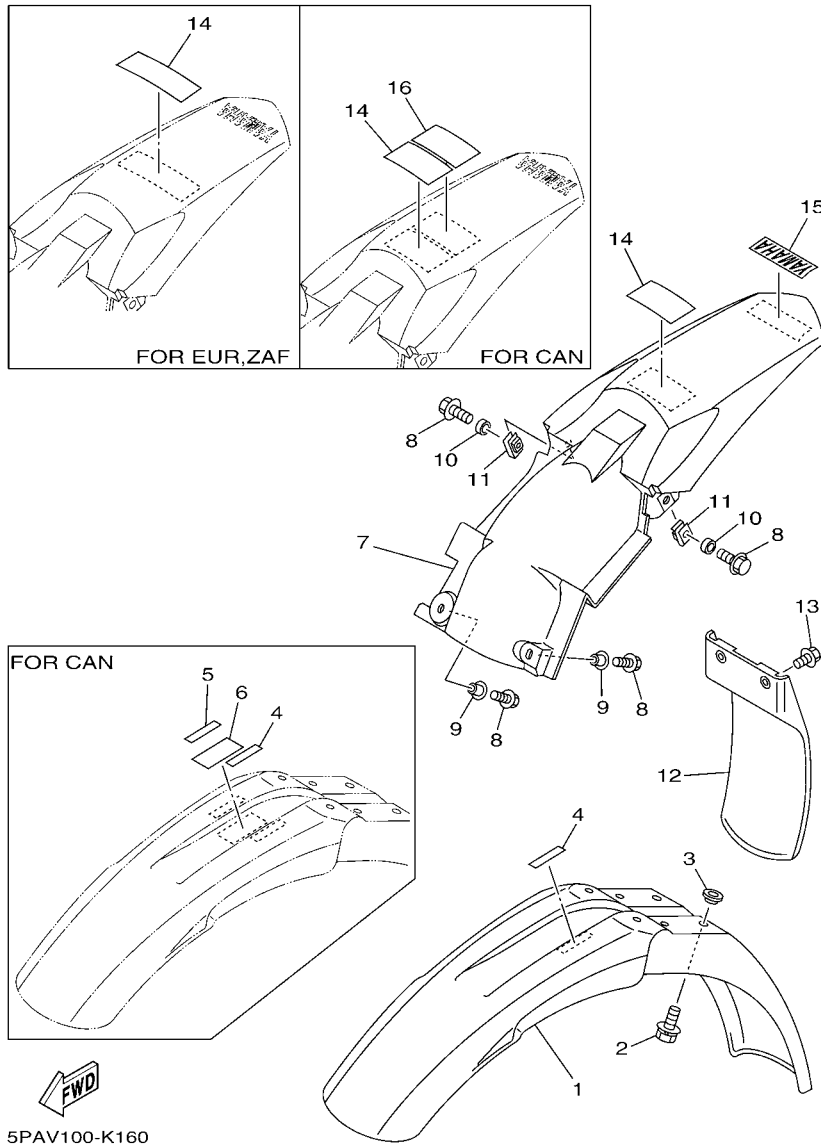

FIG. 16 FENDER

REF. NO.	PART NO.	DESCRIPTION	1SN4	1SN6	1SP4	1SP6	REMARKS
1	4ES-21511-20	FENDER, FRONT	1	1	1	1	
2	90119-06201	BOLT, WITH WASHER	4	4	4	4	
3	90209-06015	WASHER	4	4	4	4	
4	3XJ-2415E-A1	LABEL, CAUTION	1				FOR CAN
	3XJ-2415E-C1	LABEL, CAUTION			1	1	FOR JPN
5	3XJ-2415E-B1	LABEL, CAUTION	1				FOR CAN
6	4SR-2416E-00	LABEL, CAUTION CANADA	1				FOR CAN
7	5PA-21611-10	FENDER, REAR	1	1	1	1	
8	90119-06133	BOLT, WITH WASHER	4	4	4	4	
9	90387-064X4	COLLAR	2	2	2	2	
10	90387-0701A	COLLAR	2	2	2	2	
11	90183-060A7	NUT, SPRING	2	2	2	2	
12	4ES-21642-00	GUARD, FLAP	1	1	1	1	
13	90119-06239	BOLT, WITH WASHER	2	2	2	2	
14	5PA-2118K-00	LABEL, CAUTION	1				UR FOR CAN
	5PA-2118K-20	LABEL, CAUTION			1	1	FOR JPN
	5PG-2816R-00	LABEL, WARNING GENERAL INFO.			1		UR FOR EUR
15	4ES-2153E-20	EMBLEM, YAMAHA	1	1	1	1	
16	5PA-2118K-10	LABEL, CAUTION	1				FOR CAN

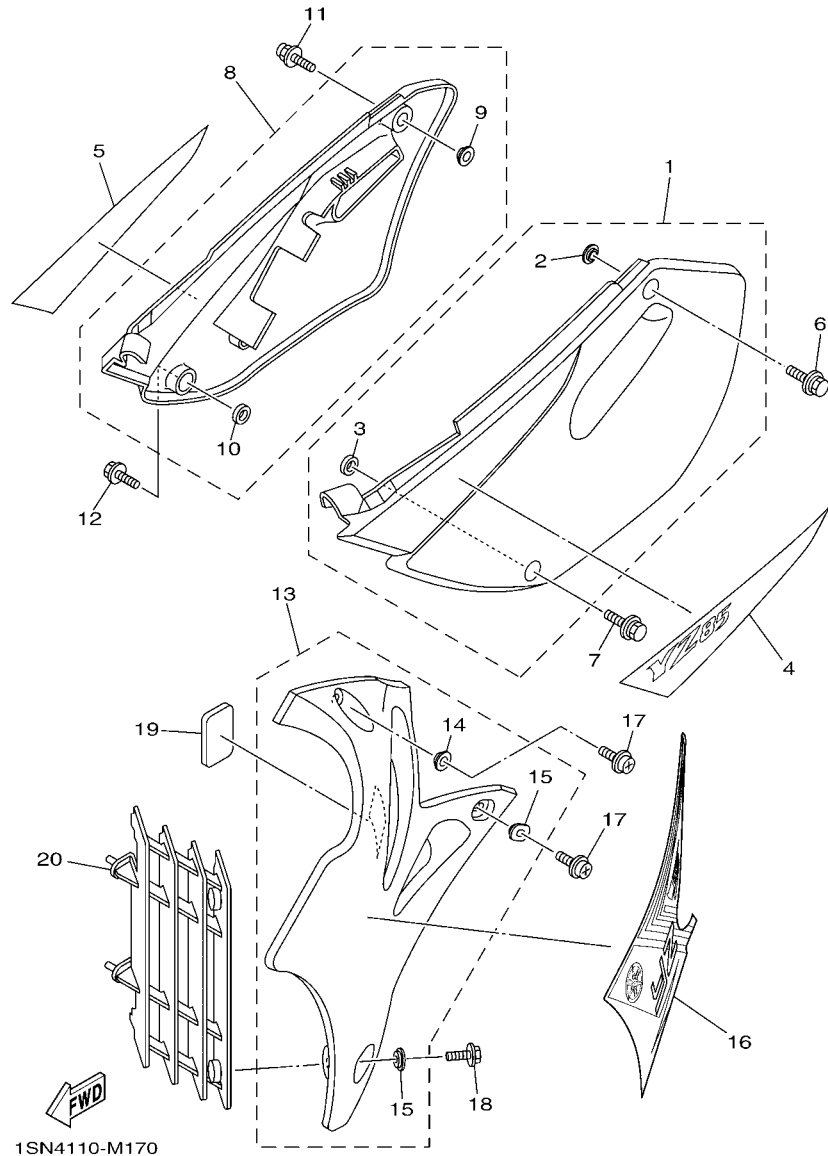
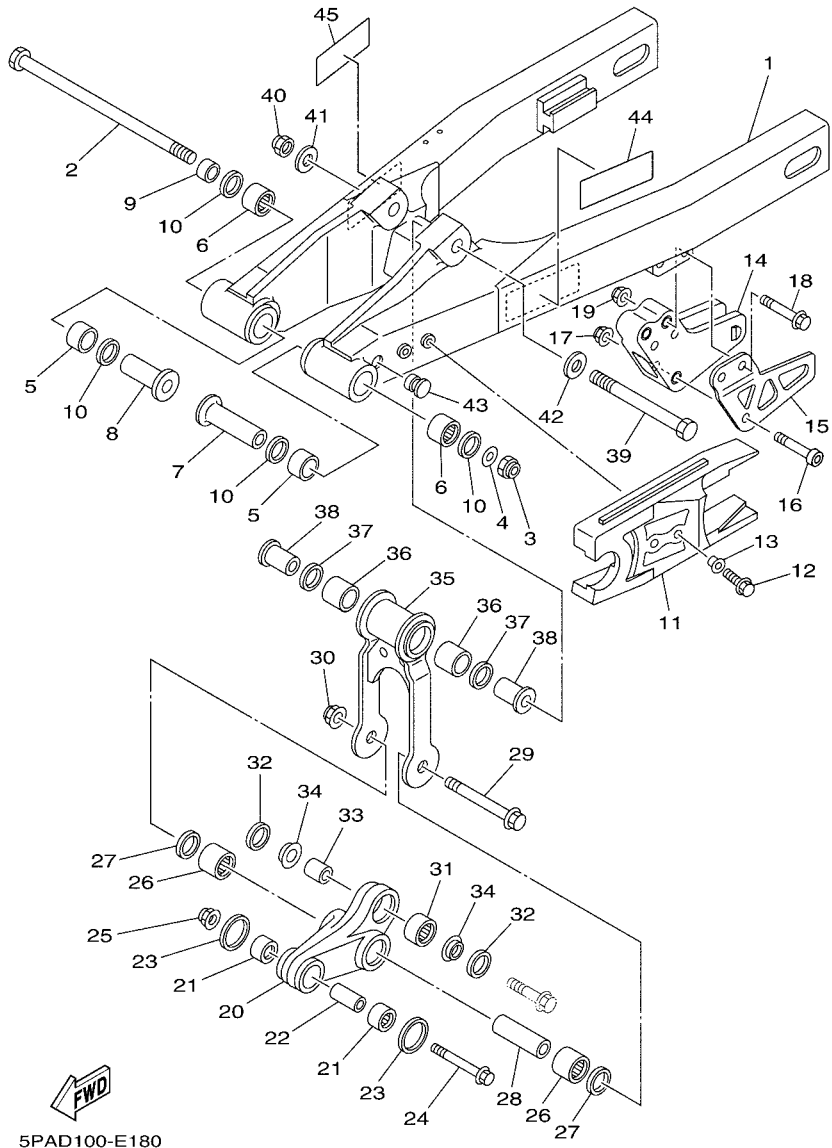

FIG. 17 SIDE COVER

REF. NO.	PART NO.	DESCRIPTION	1SN4	1SN6	1SP4	1SP6	REMARKS
1	5PA-21711-00	COVER, SIDE 1	1	1	1	1	
2	90387-06009	.COLLAR	1	1	1	1	
3	90387-1001B	.COLLAR	1	1	1	1	
4	5PA-2173E-30	GRAPHIC 1	1	1	1	1	
5	5PA-2173F-30	GRAPHIC 2	1	1	1	1	
6	90119-06240	BOLT, WITH WASHER	1	1	1	1	
7	90119-06217	BOLT, WITH WASHER	1	1	1	1	
8	5PA-21721-00	COVER, SIDE 2	1	1	1	1	
9	90387-06009	.COLLAR	1	1	1	1	
10	90387-1001B	.COLLAR	1	1	1	1	
11	90119-06240	BOLT, WITH WASHER	1	1	1	1	
12	90119-06217	BOLT, WITH WASHER	1	1	1	1	
13	5PA-21731-10	COVER, SIDE 3	1	1	1	1	
14	90387-06009	.COLLAR	1	1	1	1	
15	5PA-21748-00	.COLLAR	2	2	2	2	
16	1SN-2174G-10	GRAPHIC 3	1	1	1	1	
17	90159-06182	SCREW, WITH WASHER	2	2	2	2	
18	90159-06021	SCREW, WITH WASHER	1	1	1	1	
19	1FK-21746-00	DAMPER	1	1	1	1	
20	5PH-2172A-20	PANEL 1	1	1	1	1	



5PAD100-E180

FIG. 18 REAR ARM

REF. NO.	PART NO.	DESCRIPTION	1SN4	1SN6	1SP4	1SP6	REMARKS
1	5PA-22110-00	REAR ARM COMP.	1	1			
	5SH-22110-10	REAR ARM COMP.			1	1	
2	22W-25181-01	AXLE, WHEEL	1	1	1	1	
3	95612-12100	NUT, U	1	1	1	1	
4	90201-12032	WASHER, PLATE	1	1	1	1	
5	90385-17042	BUSH	2	2	2	2	
6	93317-21746	BEARING	2	2	2	2	
7	90387-127J8	COLLAR	1	1	1	1	
8	90387-127J7	COLLAR	1	1	1	1	
9	90387-1200U	COLLAR	1	1	1	1	
10	93109-17071	OIL SEAL	4	4	4	4	
11	5PA-22151-00	SEAL, GUARD	1	1	1	1	
12	95022-06014	BOLT, FLANGE	2	2	2	2	
13	90387-06180	COLLAR	2	2	2	2	
14	5PA-22199-00	SUPPORT, CHAIN	1	1	1	1	
15	5PA-22128-00	COVER, THRUST 1	1	1	1	1	
16	92012-06040	BOLT, BUTTON HEAD	1	1	1	1	
17	95602-06200	NUT, SELF-LOCKING	1	1	1	1	
18	95022-08050	BOLT, FLANGE	2	2	2	2	
19	95602-08200	NUT, SELF-LOCKING	2	2	2	2	
20	5PA-2217A-00	ARM, RELAY	1	1	1	1	
21	93315-21455	BEARING	2	2	2	2	
22	90380-10218	BUSH, SOLID	1	1	1	1	
23	4ES-22129-00	COVER, THRUST 2	2	2	2	2	
24	90105-10582	BOLT, FLANGE	1	1	1	1	
25	95602-10200	NUT, U FLANGE	1	1	1	1	
26	93317-31771	BEARING	2	2	2	2	

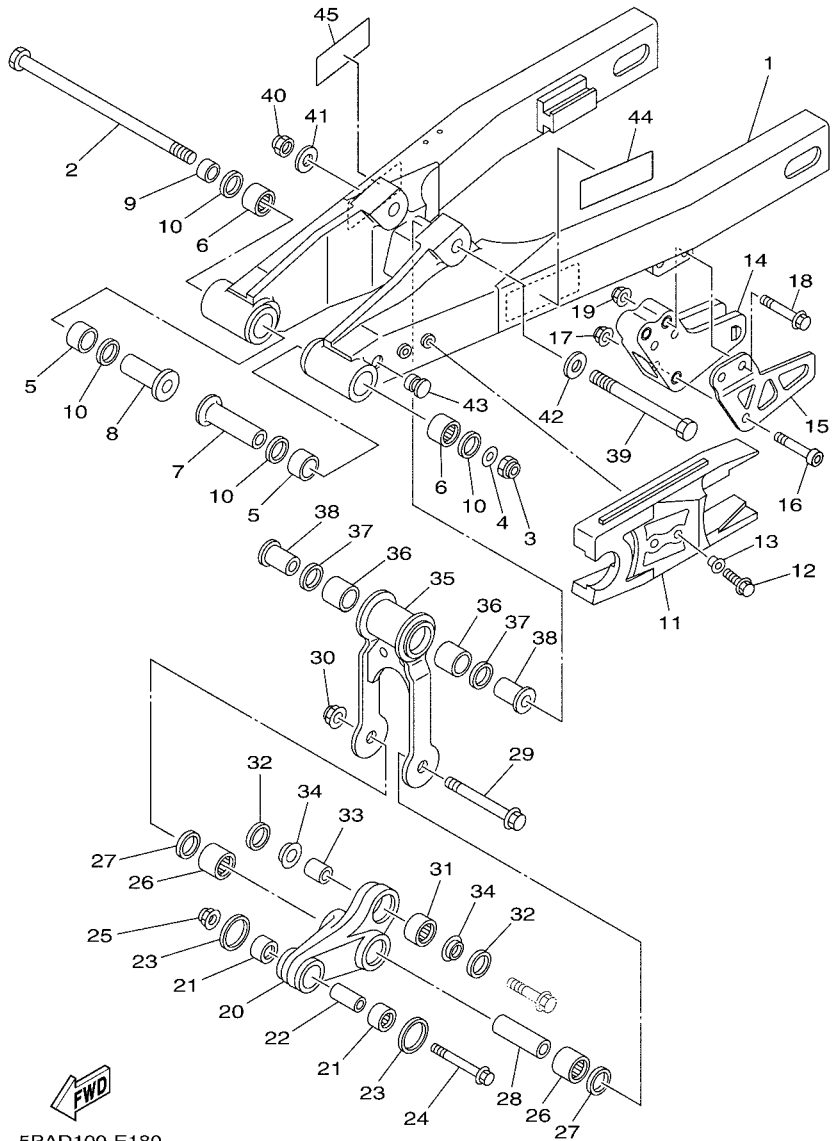
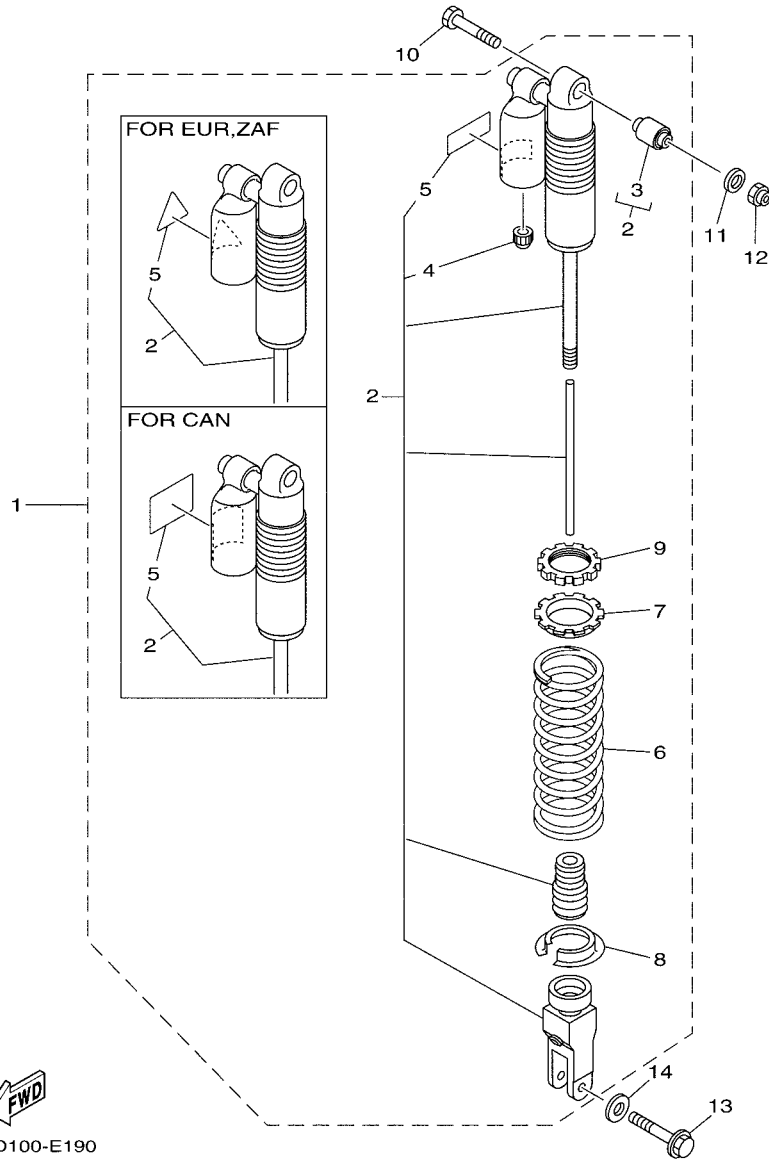

FIG. 18 REAR ARM

REF. NO.	PART NO.	DESCRIPTION	1SN4	1SN6	1SP4	1SP6	REMARKS
27	93101-17062	OIL SEAL	2	2	2	2	
28	90380-12219	BUSH, SOLID	1	1	1	1	
29	90109-12015	BOLT	1	1	1	1	
30	95602-12200	NUT, SELF-LOCKING	1	1	1	1	
31	5PA-22176-00	BEARING	1	1	1	1	
32	5PA-22475-00	SEAL, DUST	2	2	2	2	
33	5PA-22184-00	BUSH	1	1	1	1	
34	5PA-22253-00	COLLAR, DISTANCE	2	2	2	2	
35	4ES-2217F-00	ROD, CONNECTING 1	1	1	1	1	
36	93317-31771	BEARING	2	2	2	2	
37	93101-17062	OIL SEAL	2	2	2	2	
38	90381-12091	BUSH, SOLID	2	2	2	2	
39	90101-12755	BOLT	1	1	1	1	
40	90185-12011	NUT, SELF-LOCKING	1	1	1	1	
41	90201-12047	WASHER, PLATE	1	1	1	1	
42	90201-12049	WASHER, PLATE	1	1	1	1	
43	90338-10150	PLUG	2	2	2	2	
44	3RV-21668-A0	LABEL, TIRE	1				
45	3RV-21668-B0	LABEL, TIRE	1				

FIG. 19 REAR SUSPENSION



REF. NO.	PART NO.	DESCRIPTION	1SN4	1SN6	1SP4	1SP6	REMARKS
1	5PA-22210-80	SHOCK ABSORBER ASSY, REAR	1				
	5PA-22210-70	SHOCK ABSORBER ASSY, REAR		1			
	5SH-22210-40	SHOCK ABSORBER ASSY, REAR			1		
	5SH-22210-50	SHOCK ABSORBER ASSY, REAR				1	
2	5PA-22201-80	.DAMPER SUB ASSY	1				
	5PA-22201-70	.DAMPER SUB ASSY		1			
	5SH-22201-40	.DAMPER SUB ASSY			1		
	5SH-22201-50	.DAMPER SUB ASSY				1	
3	4ES-22216-00	..BUSH, REAR SHOCK ABSORBER	1	1	1	1	
4	58T-23184-L0	..CAP, AIR VALVE	1	1	1	1	
5	4AA-22259-60	..LABEL, WARNING	1				
	4AA-22259-50	..LABEL, WARNING		1		1	
	4AA-22259-40	..LABEL, WARNING			1		
6	4ES-22212-F0	.SPRING (K=49N/MM)	1	1			
	4ES-22212-G0	.SPRING (K=47N/MM)			1		
	4ES-22212-H0	.SPRING (K=51N/MM)				1	
7	4ES-22214-00	.GUIDE, SPRING 1	1	1	1	1	
8	3JD-22214-00	.GUIDE, SPRING 1	1	1	1	1	
9	4ES-22251-00	.NUT 1	1	1	1	1	
10	90109-10729	BOLT	1	1	1	1	
11	92902-10600	WASHER, PLATE	1	1	1	1	
12	90185-10018	NUT, SELF-LOCKING	1	1	1	1	
13	90105-10614	BOLT, FLANGE	1	1	1	1	
14	90201-11016	WASHER, PLATE	1	1	1	1	

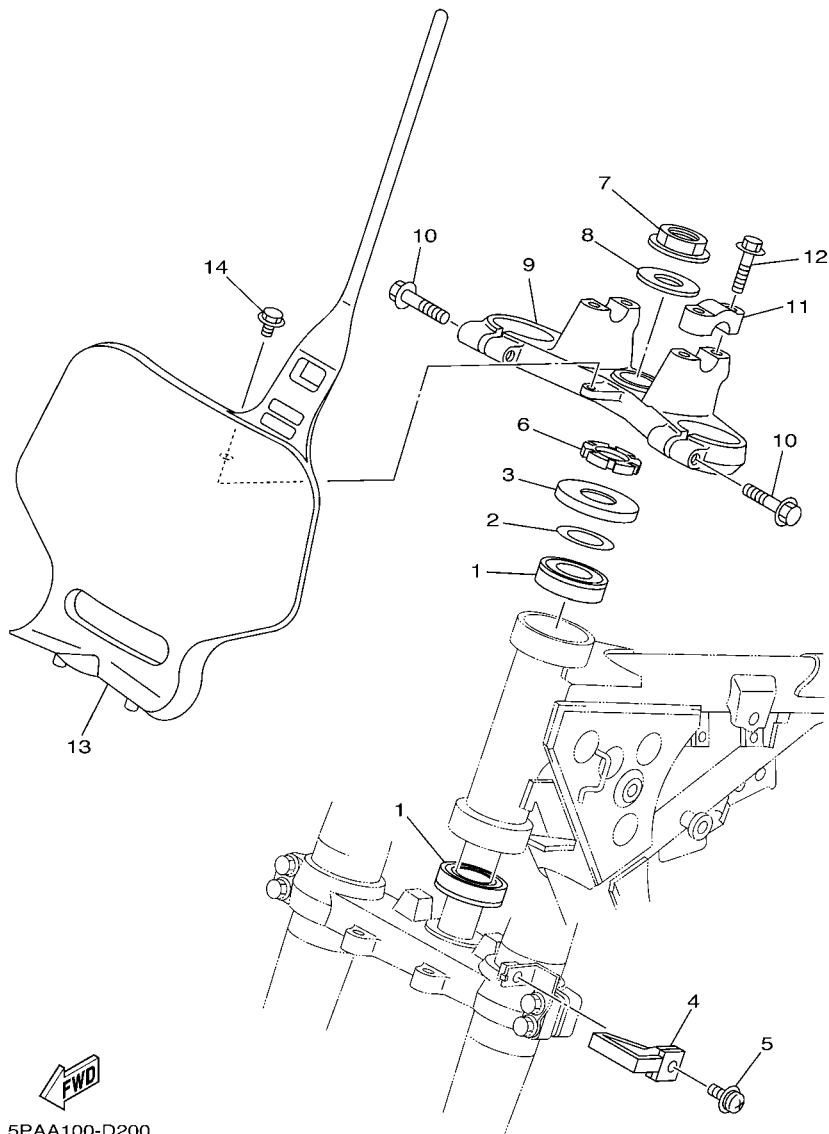

5PAA100-D200

FIG. 20 STEERING

REF. NO.	PART NO.	DESCRIPTION	1SN4	1SN6	1SP4	1SP6	REMARKS
1	93332-00079	BEARING	2	2	2	2	
2	90201-256K5	WASHER, PLATE (0.5T)	1	1	1	1	
3	1J7-23415-00	COVER, BALL RACE 1	1	1	1	1	
4	4DA-23389-00	GUIDE, CABLE	1	1	1	1	
5	90157-05029	SCREW, PAN HEAD	1	1	1	1	
6	90179-25004	NUT	1	1	1	1	
7	90179-22025	NUT	1	1	1	1	
8	90201-220T0	WASHER, PLATE	1	1	1	1	
9	4ES-23435-00	CROWN, HANDLE	1	1	1	1	
10	95802-08035	BOLT, FLANGE	2	2	2	2	
11	3SP-23441-00	HOLDER, HANDLE UPPER	2	2	2	2	
12	95022-08030	BOLT, FLANGE	4	4	4	4	
13	4ES-23485-00	PLATE, NUMBER	1	1	1	1	
14	95022-06012	BOLT, FLANGE	1	1	1	1	

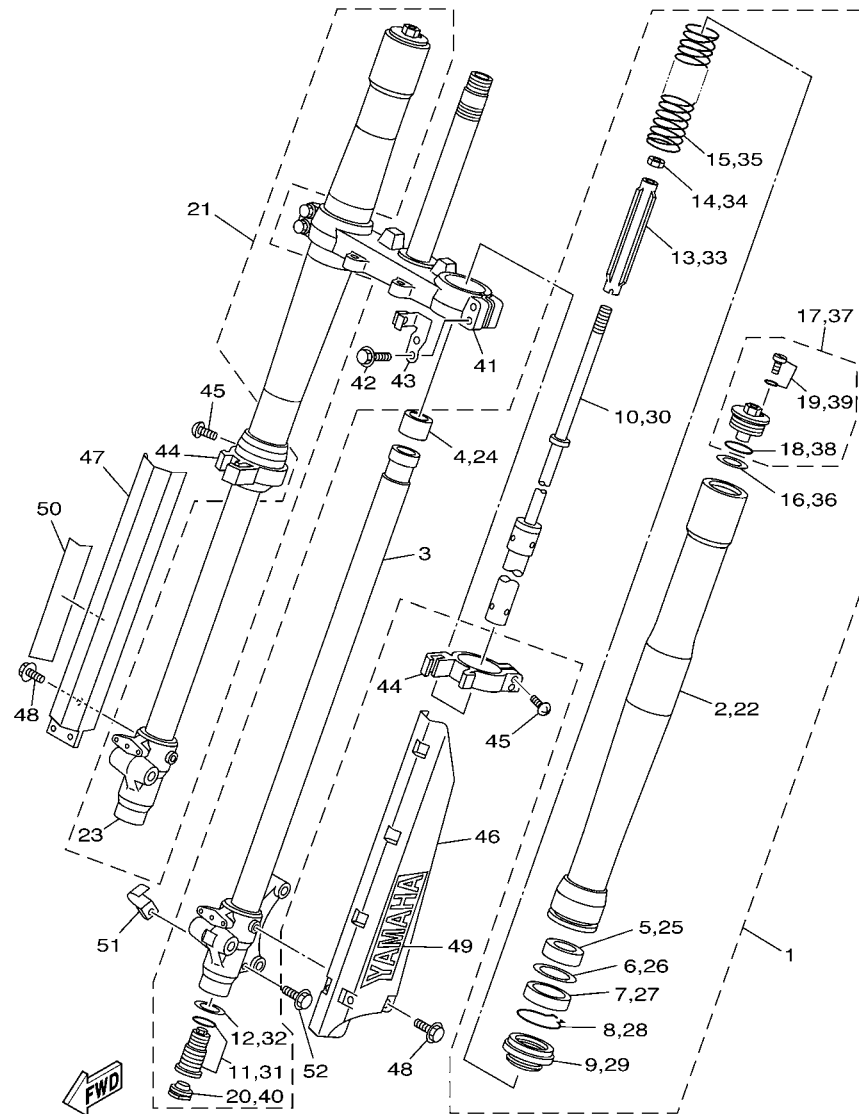

5PA7100-C210

FIG. 21 FRONT FORK

REF. NO.	PART NO.	DESCRIPTION	1SN4	1SN6	1SP4	1SP6	REMARKS
1	5PA-23102-10	FRONT FORK ASSY (L.H)	1	1			
	5SH-23102-10	FRONT FORK ASSY (L.H)			1	1	
2	5PA-23136-10	.TUBE, OUTER (RIGHT)	1	1	1	1	
3	5PA-23120-00	.INNER TUBE COMP.2	1	1	1	1	
4	5PA-23171-00	.PISTON, FRONT FORK	1	1	1	1	
5	5PA-23125-00	.METAL, SLIDE 1	1	1	1	1	
6	5K5-23149-00	.WASHER, SPRING UPPER	1	1	1	1	
7	4ES-23145-00	.OIL SEAL	1	1	1	1	
8	4A1-23156-00	.RING, SNAP	1	1	1	1	
9	4ES-23144-00	.SEAL, DUST	1	1	1	1	
10	5PA-23170-00	.CYLINDER COMP., FRONT FORK	1	1	1	1	
11	5PA-2316A-00	.VALVE COMP.	1	1			
	5SH-2316A-00	.VALVE COMP.			1	1	
12	2HH-23158-L0	.GASKET	1	1	1	1	
13	4ES-23142-00	.SEAT, SPRING UPPER	1	1	1	1	
14	3XJ-23357-L0	.NUT	1	1	1	1	
15	4ES-23141-40	.SPRING, FRONT FORK(K=2.8N/MM)	1	1			
	4LB-23141-10	.SPRING, FRONT FORK(K=2.9N/MM)			1	1	
16	5PA-23149-00	.WASHER, SPRING UPPER	1	1	1	1	
17	4ES-23111-10	.BOLT, CAP	1	1	1	1	
18	4V4-23188-L0	.O-RING	1	1	1	1	
19	3JD-23394-00	.BOLT, SPECIAL	1	1	1	1	
20	3JD-2312G-L0	.PLUG	1	1	1	1	
21	5PA-23103-10	FRONT FORK ASSY (R.H)	1	1			
	5SH-23103-10	FRONT FORK ASSY (R.H)			1	1	
22	5PA-23136-10	.TUBE, OUTER (RIGHT)	1	1	1	1	
23	5PA-23110-00	.INNER TUBE COMP.1	1	1	1	1	

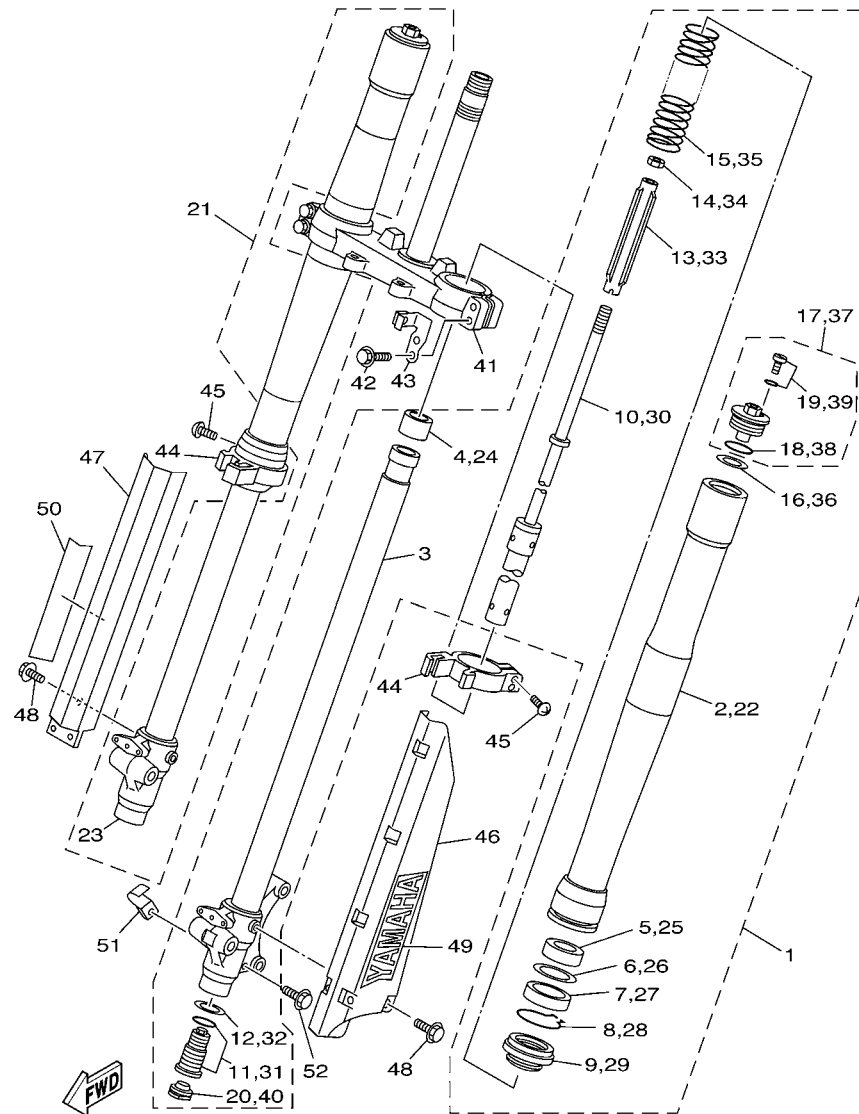

5PA7100-C210

FIG. 21 FRONT FORK

REF. NO.	PART NO.	DESCRIPTION	1SN4	1SN6	1SP4	1SP6	REMARKS
24	5PA-23171-00	.PISTON, FRONT FORK	1	1	1	1	
25	5PA-23125-00	.METAL, SLIDE 1	1	1	1	1	
26	5K5-23149-00	.WASHER, SPRING UPPER	1	1	1	1	
27	4ES-23145-00	.OIL SEAL	1	1	1	1	
28	4A1-23156-00	.RING, SNAP	1	1	1	1	
29	4ES-23144-00	.SEAL, DUST	1	1	1	1	
30	5PA-23170-00	.CYLINDER COMP., FRONT FORK	1	1	1	1	
31	5PA-2316A-00	.VALVE COMP.	1	1			
	5SH-2316A-00	.VALVE COMP.			1	1	
32	2HH-23158-L0	.GASKET	1	1	1	1	
33	4ES-23142-00	.SEAT, SPRING UPPER	1	1	1	1	
34	3XJ-23357-L0	.NUT	1	1	1	1	
35	4ES-23141-40	.SPRING, FRONT FORK(K=2.8N/MM)	1	1			
	4LB-23141-10	.SPRING, FRONT FORK(K=2.9N/MM)			1	1	
36	5PA-23149-00	.WASHER, SPRING UPPER	1	1	1	1	
37	4ES-23111-10	.BOLT, CAP	1	1	1	1	
38	4V4-23188-L0	.O-RING	1	1	1	1	
39	3JD-23394-00	.BOLT, SPECIAL	1	1	1	1	
40	3JD-2312G-L0	.PLUG	1	1	1	1	
41	5PA-23340-01	UNDER BRACKET COMP.	1	1	1	1	
42	5PA-23346-00	BOLT 1	4	4	4	4	
43	5PA-2331E-10	GUIDE, CABLE	1	1	1	1	
44	4ES-2314F-00	PROTECTOR GUIDE COMP., 1	2	2	2	2	
45	4V4-23194-L0	SCREW, BOOT BAND	4	4	4	4	
46	5PA-2314H-L0	PROTECTOR COMP., 1	1	1	1	1	
47	5PA-2314J-L0	PROTECTOR COMP., 2	1	1	1	1	
48	95024-06010	BOLT, FLG.(SMALL HEAD)	6	6	6	6	

FIG. 22 FUEL TANK

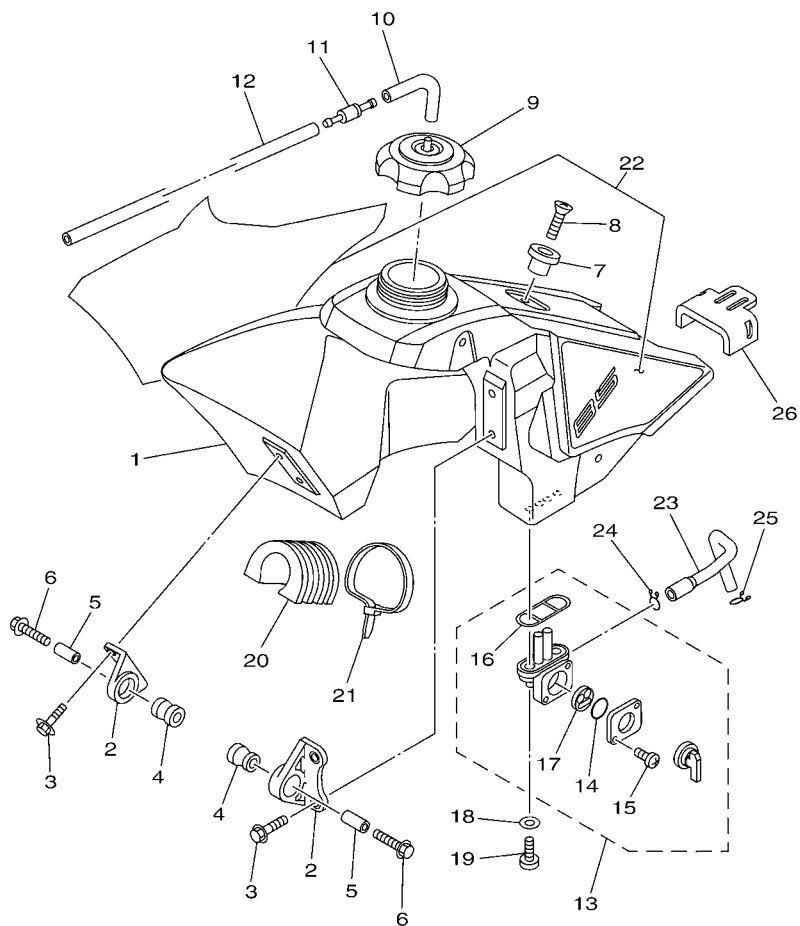

1SN4110-M220

REF. NO.	PART NO.	DESCRIPTION	1SN4	1SN6	1SP4	1SP6	REMARKS
1	5PA-24110-30	FUEL TANK COMP.	1	1	1	1	
2	5XE-24144-00	HOLDER, DAMPER	2	2	2	2	
3	95027-06016	BOLT, FLANGE	4	4	4	4	
4	90480-18549	GROMMET	2	2	2	2	
5	90387-06027	COLLAR	2	2	2	2	
6	90119-06190	BOLT, WITH WASHER	2	2	2	2	
7	4EW-2412F-00	BRACKET, SEAT	1	1	1	1	
8	98702-06025	SCREW, FLAT HEAD	1	1	1	1	
9	5NY-24610-10	CAP ASSY	1	1	1	1	
10	90445-09003	HOSE (L30)	1	1	1	1	
11	3XJ-24380-00	PIPE JOINT ASSY	1	1	1	1	
12	90445-09005	HOSE	1	1	1	1	
13	4DP-24500-10	FUEL COCK ASSY 1	1	1	1	1	
14	3AJ-24534-10	.SEAL, COCK	1	1	1	1	
15	98507-03008	.SCREW, PAN HEAD	2	2	2	2	
16	4X8-24512-10	.GASKET	1	1	1	1	
17	3AC-24523-00	.VALVE PACKING	1	1	1	1	
18	90202-05193	WASHER, PLATE	2	2	2	2	
19	90149-06108	SCREW	2	2	2	2	
20	5PA-24182-00	DAMPER, LOCATING 2	1	1	1	1	
21	90465-13275	CLAMP	1	1	1	1	
22	1SN-24240-10	GRAPHIC SET	1	1	1	1	
23	5PA-24311-00	PIPE, FUEL 1	1	1	1	1	
24	90467-10008	CLIP	1	1	1	1	
25	90467-09002	CLIP	1	1	1	1	
26	5PA-24181-00	DAMPER, LOCATING 1	1	1	1	1	

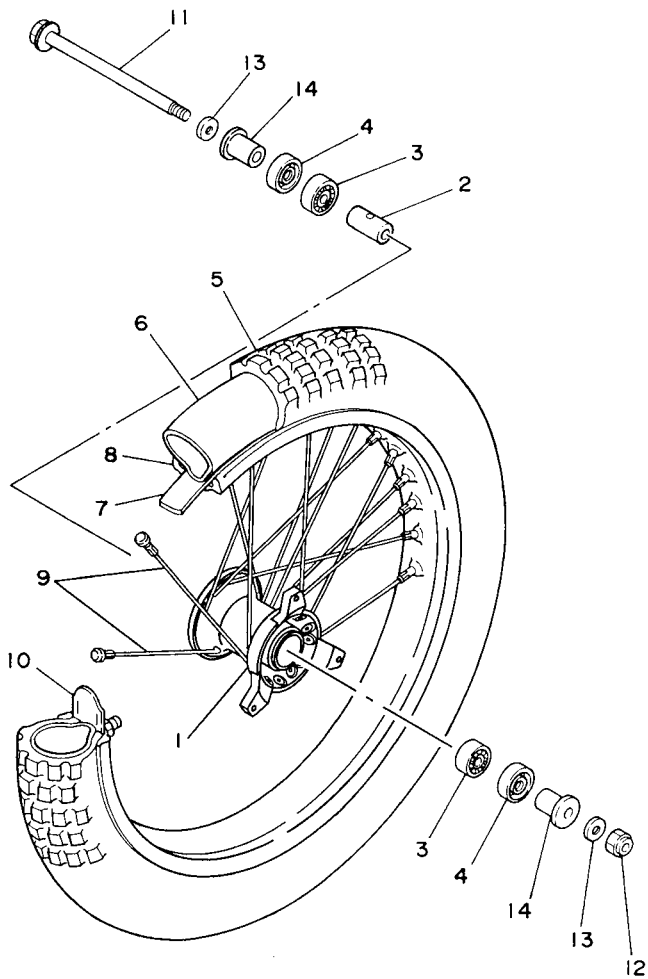

4ES1100-3240

FIG. 24 FRONT WHEEL

REF. NO.	PART NO.	DESCRIPTION	1SN4	1SN6	1SP4	1SP6	REMARKS
1	4ES-25111-00	HUB, FRONT	1	1	1	1	
2	90387-124H0	COLLAR	1	1	1	1	
3	93306-20120	BEARING	2	2	2	2	
4	93106-20031	OIL SEAL	2	2	2	2	
5	94107-17012	TIRE (70/100-17 40M D756F)	1				DUNLOP
	94107-17019	TIRE (70/100-17 40M D739FA)		1			DUNLOP
	94107-19015	TIRE (70/100-19 42M D756F)			1		DUNLOP
	94107-19012	TIRE (70/100-19 42M D739FA)				1	DUNLOP
6	94207-17284	TUBE (70/100-17M/C TR4)	1	1			DUNLOP
	94207-19290	TUBE (70/100-19M/C TR4)			1	1	DUNLOP
7	94307-17166	BAND, RIM (22-17)	1	1			DUNLOP
	94307-19170	BAND, RIM (18-19)			1	1	DUNLOP
8	94414-17530	RIM (1.40-17)	1	1			
	94414-19521	RIM (1.40-19)			1	1	
9	4ES-25104-20	SPOKE SET, FRONT	1	1			
	4LB-25104-00	SPOKE SET, FRONT			1	1	
10	1T1-25194-00	SPACER, BEAD	1	1	1	1	
11	4ES-25181-00	AXLE, WHEEL	1	1	1	1	
12	90185-12010	NUT, SELF-LOCKING	1	1	1	1	
13	90201-12055	WASHER, PLATE	2	2	2	2	
14	4ES-25183-10	COLLAR, WHEEL	2	2	2	2	

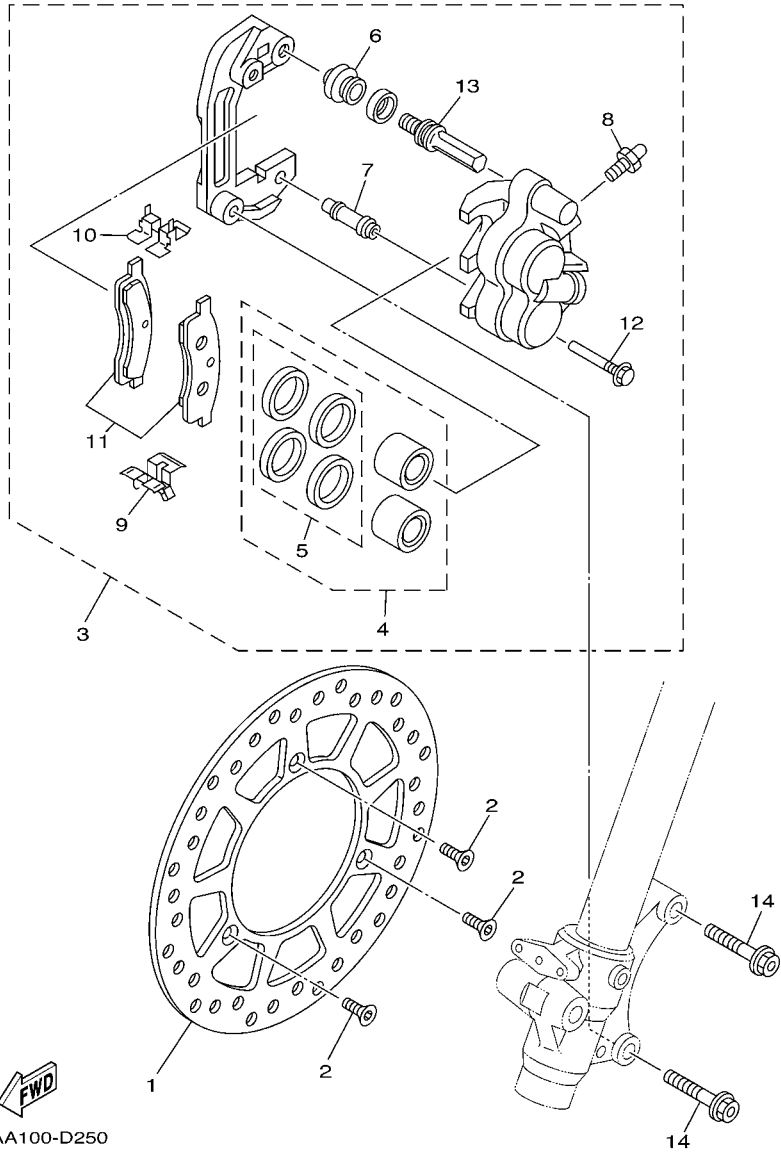

5PAA100-D250

FIG. 25 FRONT BRAKE CALIPER

REF. NO.	PART NO.	DESCRIPTION	1SN4	1SN6	1SP4	1SP6	REMARKS
1	5PA-2582T-00	DISC, BRAKE (LEFT)	1	1	1	1	
2	90149-06327	SCREW	3	3	3	3	
3	5PA-2580T-00	CALIPER ASSY (LEFT)	1	1	1	1	
4	4ES-W0057-10	.PISTON ASSY, CALIPER	1	1	1	1	
5	4ES-W0047-10	..CALIPER SEAL KIT	1	1	1	1	
6	5R2-25937-00	.BOOT 2	1	1	1	1	
7	56A-25937-00	.BOOT 2	1	1	1	1	
8	51L-W0048-00	.BLEED SCREW KIT	1	1	1	1	
9	56A-25919-00	.SUPPORT, PAD	1	1	1	1	
10	56A-25919-10	.SUPPORT, PAD	1	1	1	1	
11	5PA-W0045-00	.BRAKE PAD KIT	1	1	1	1	
12	56A-25926-00	.BOLT	1	1	1	1	
13	34X-25914-00	.PIN, SLIDE	1	1	1	1	
14	90105-08211	BOLT, FLANGE	2	2	2	2	

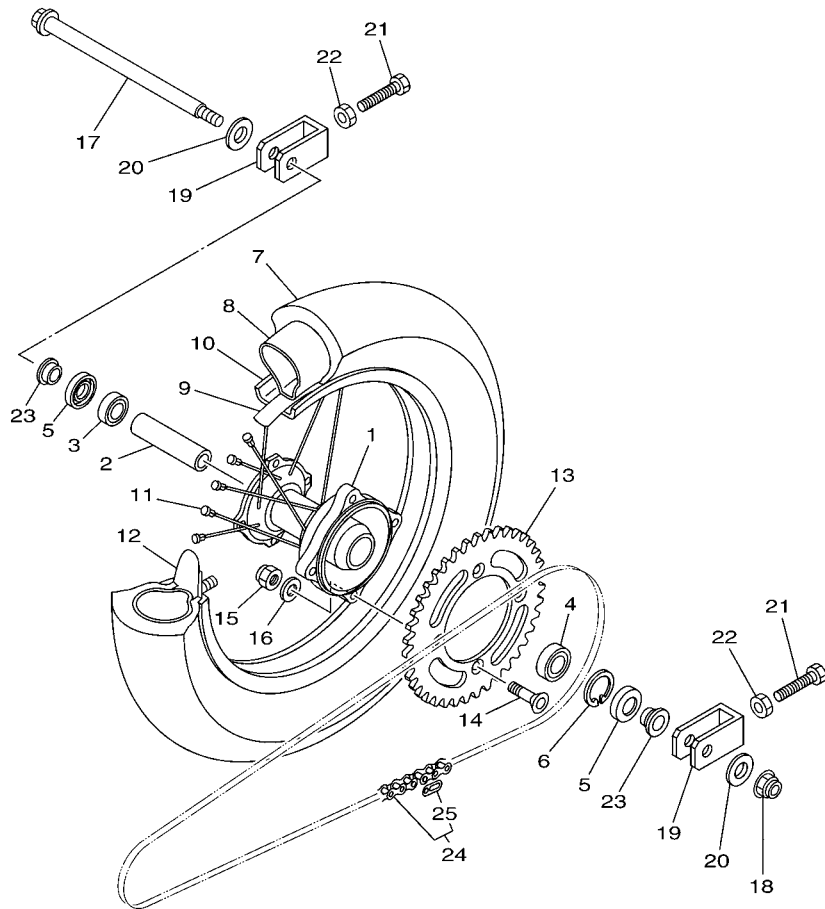

1SN1100-L260

FIG. 26 REAR WHEEL

REF. NO.	PART NO.	DESCRIPTION	1SN4	1SN6	1SP4	1SP6	REMARKS
1	4ES-25311-00	HUB, REAR	1	1	1	1	
2	4ES-25383-00	COLLAR, WHEEL	1	1	1	1	
3	93306-00203	BEARING	1	1	1	1	
4	93306-20203	BEARING	1	1	1	1	
5	93102-20009	OIL SEAL	2	2	2	2	
6	99009-35500	CIRCLIP	1	1	1	1	
7	94109-14012	TIRE (90/100-14 49M D756)	1				DUNLOP
	94109-14015	TIRE (90/100-14 49M D739)		1			DUNLOP
	94109-16015	TIRE (90/100-16 52M D756)			1		DUNLOP
	94109-16012	TIRE (90/100-16 52M D739)				1	DUNLOP
8	94208-14285	TUBE (80-90/100-14M/C TR4)	1	1			DUNLOP
	94209-16291	TUBE (90/100-16M/C TR4)			1	1	DUNLOP
9	94308-14165	BAND, RIM (22-14)	1	1			DUNLOP
	94307-16171	BAND, RIM (18-16)			1	1	DUNLOP
10	94416-14529	RIM (1.60-14)	1	1			
	94418-16522	RIM (1.85-16)			1	1	
11	4ES-25304-20	SPOKE SET, REAR	1	1			
	4LB-25304-00	SPOKE SET, REAR			1	1	
12	5X2-25394-00	SPACER, BEAD	1	1			
	1T2-25394-00	SPACER, BEAD			1	1	
13	4ES-25447-20	SPROCKET, DRIVEN (47T)	1	1			STD AFAM
	5PA-25446-00	SPROCKET, DRIVEN (46T)	1	1			AP
	5PA-25448-00	SPROCKET, DRIVEN (48T)	1				AP
	5PA-25449-00	SPROCKET, DRIVEN (49T)	1				AP
	5PA-25452-00	SPROCKET, DRIVEN (52T)			1	1	STD
	5PA-25451-00	SPROCKET, DRIVEN (51T)			1	1	AP
	5PA-25453-00	SPROCKET, DRIVEN (53T)			1	1	AP

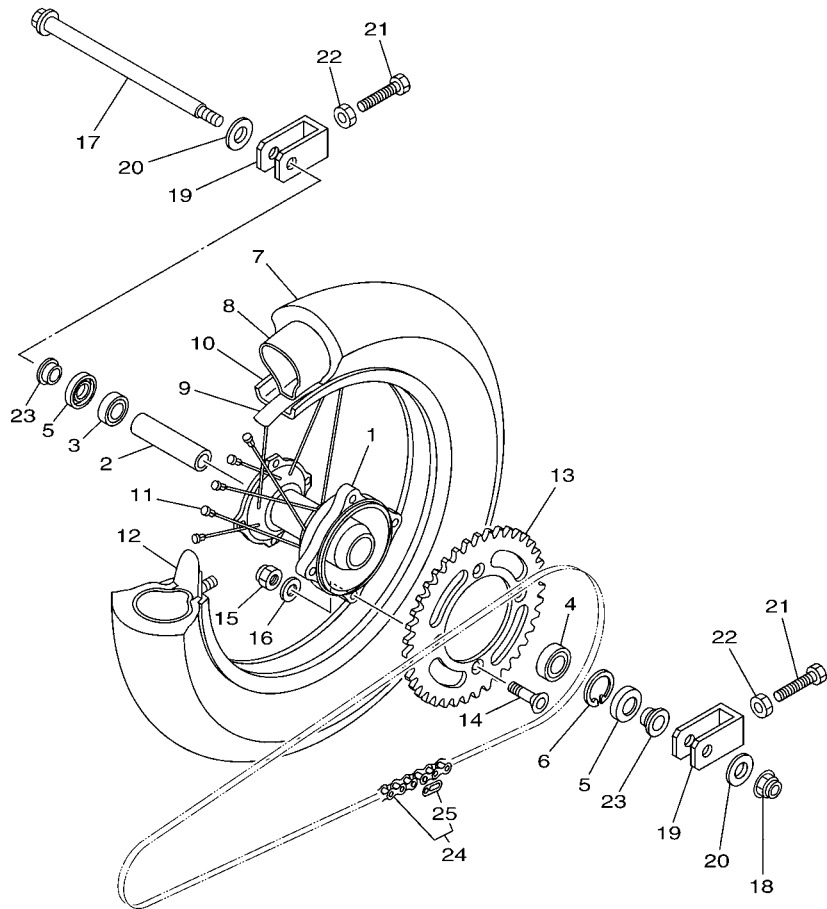

FWD
1SN1100-L260

FIG. 26 REAR WHEEL

REF. NO.	PART NO.	DESCRIPTION	1SN4	1SN6	1SP4	1SP6	REMARKS
14	90152-08001	SCREW, COUNTERSUNK	4	4	4	4	
15	90185-08008	NUT, SELF-LOCKING	4	4	4	4	
16	90201-08043	WASHER, PLATE	4	4	4	4	
17	4ES-25381-01	AXLE, WHEEL	1	1	1	1	
18	90185-14012	NUT, SELF-LOCKING	1	1	1	1	
19	5PA-25388-00	PULLER, CHAIN 1	2	2	2	2	
20	90201-15027	WASHER, PLATE	2	2	2	2	
21	90101-08060	BOLT	2	2	2	2	
22	95302-08700	NUT	2	2	2	2	
23	4ES-25383-10	COLLAR, WHEEL	2	2	2	2	
24	9Y582-00117	CHAIN (DID 428DS 118L)	1	1			
	9Y582-00123	CHAIN (DID 428DS 124L)			1	1	
25	94682-00001	.JOINT,CHAIN (DID 428DS-RJ)	1	1	1	1	

FIG. 27 REAR BRAKE CALIPER

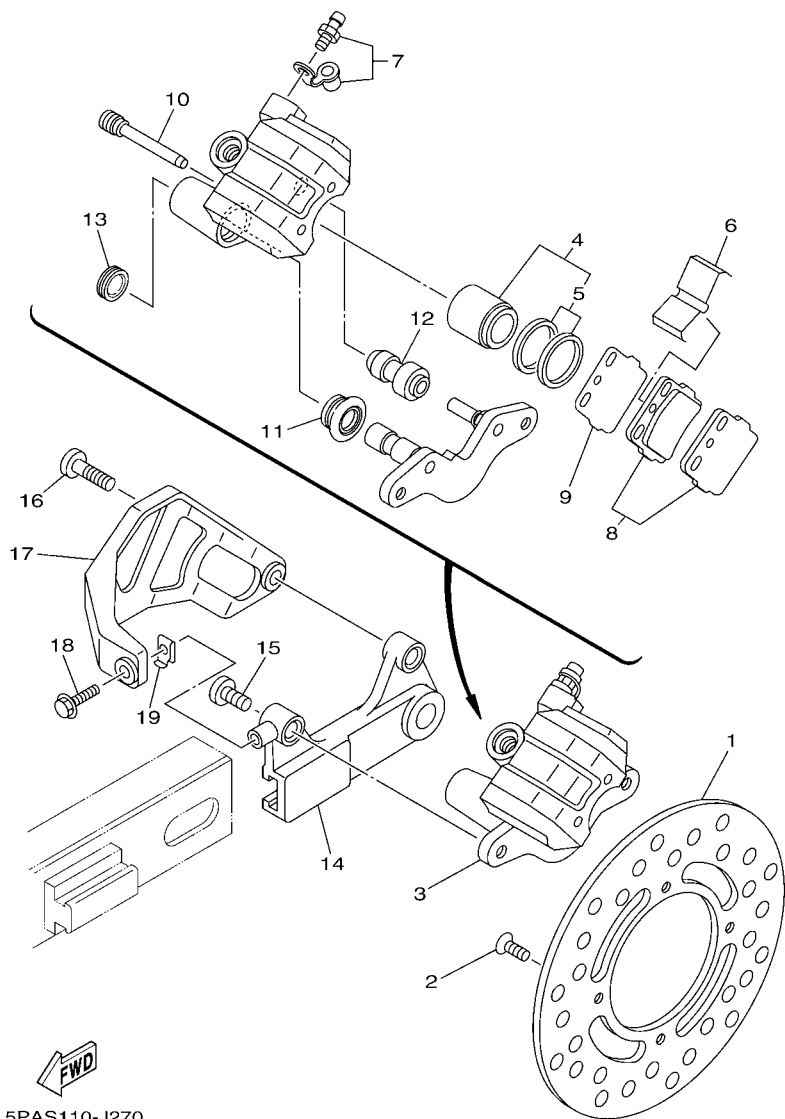

REF. NO.	PART NO.	DESCRIPTION	1SN4	1SN6	1SP4	1SP6	REMARKS
1	5PA-2582W-00	DISK, REAR BRAKE 2	1	1	1	1	
2	90149-06327	SCREW	4	4	4	4	
3	5PA-2580W-00	CALIPER ASSY, REAR 2	1	1	1	1	
4	4EW-W0057-50	.PISTON ASSY, CALIPER	1	1	1	1	
5	4ES-W0047-00	..CALIPER SEAL KIT	1	1	1	1	
6	1UY-25919-51	.SUPPORT, PAD	1	1	1	1	
7	1UY-W0048-50	.BLEED SCREW KIT	1	1	1	1	
8	5PA-W0046-50	.BRAKE PAD KIT 2	1	1	1	1	
9	3GD-25827-00	.SHIM, CALIPER	1	1	1	1	
10	3GD-25933-00	.PIN, PAD	2	2	2	2	
11	1UY-25917-51	.BOOT, CALIPER	1	1	1	1	
12	1UY-25937-51	.BOOT 2	1	1	1	1	
13	3GD-25916-00	.PLUG	1	1	1	1	
14	4ES-25920-00	SUPT. BRKT. ASSY.	1	1	1	1	
15	90111-08029	BOLT,HEX. SOCKET BUTTON	1	1	1	1	
16	90109-08718	BOLT	1	1	1	1	
17	5PA-27491-00	PROTECTOR	1	1	1	1	
18	90105-06078	BOLT, FLANGE	1	1	1	1	
19	4ES-27114-00	STOPPER, MAIN STAND	1	1	1	1	

FIG. 29 FRONT MASTER CYLINDER

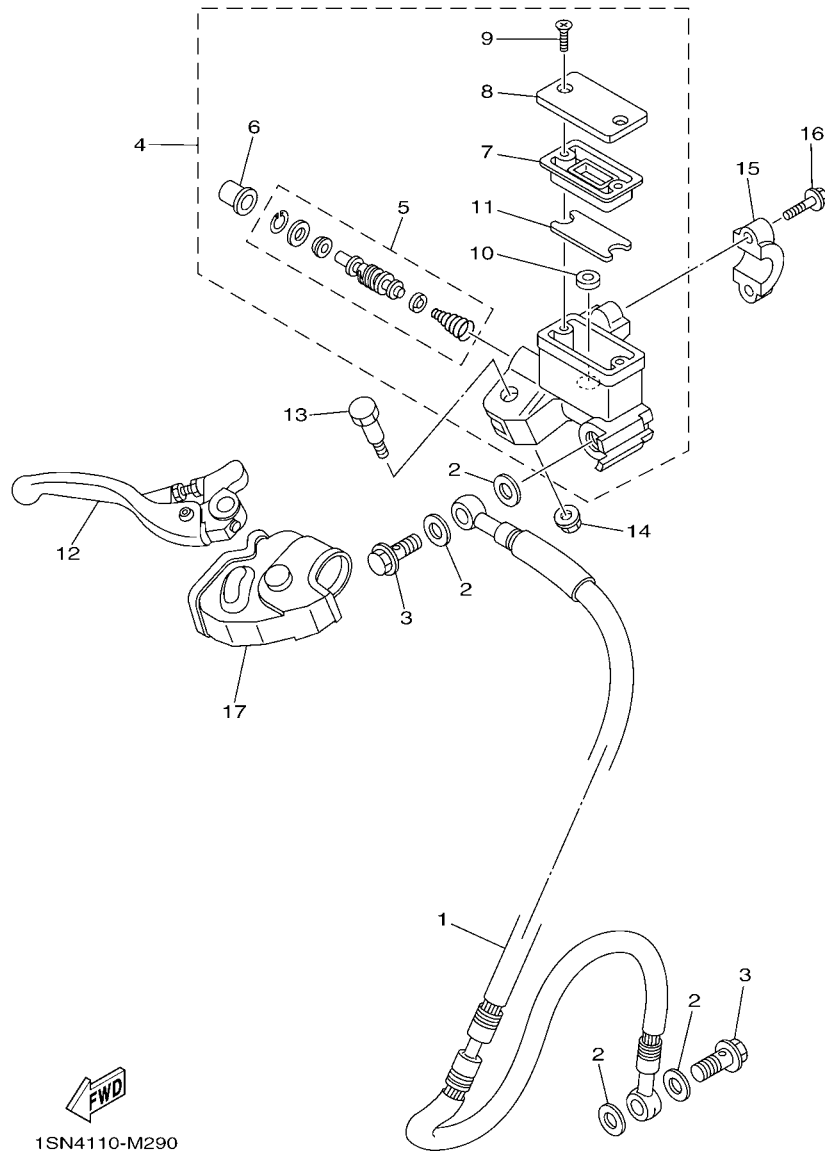

REF. NO.	PART NO.	DESCRIPTION	1SN4	1SN6	1SP4	1SP6	REMARKS
1	4ES-25872-11	HOSE, BRAKE 1	1	1			
	5SH-25872-01	HOSE, BRAKE 1			1	1	
2	90430-10005	GASKET	4	4	4	4	
3	90401-10168	BOLT, UNION	2	2	2	2	
4	5XE-W2587-00	MASTER CYLINDER SUB ASSY	1	1	1	1	
5	5NY-W0041-01	.CYLINDER KIT, MASTER	1	1	1	1	
6	5NY-25868-00	.BOOT, MASTER CYLINDER	1	1	1	1	
7	5XE-25854-00	.DIAPHRAGM, RESERVOIR	1	1	1	1	
8	5MV-25852-01	.CAP, RESERVOIR	1	1	1	1	
9	98706-04012	.SCREW, FLAT HEAD	2	2	2	2	
10	5CG-25715-00	.SEPARATOR ASSY	1	1	1	1	
11	5XE-25853-00	.FLOAT, RESERVOIR	1	1	1	1	
12	5MV-83922-00	LEVER 2	1	1	1	1	
13	5MV-2589F-00	BOLT, LEVER	1	1	1	1	
14	95701-06500	NUT, WITH WASHER	1	1	1	1	
15	5MV-25867-00	BRACKET, MASTER CYLINDER	1	1	1	1	
16	5MV-25833-00	BOLT, FITTING	2	2	2	2	
17	5NY-26372-00	COVER, HANDLE LEVER 1	1	1	1	1	

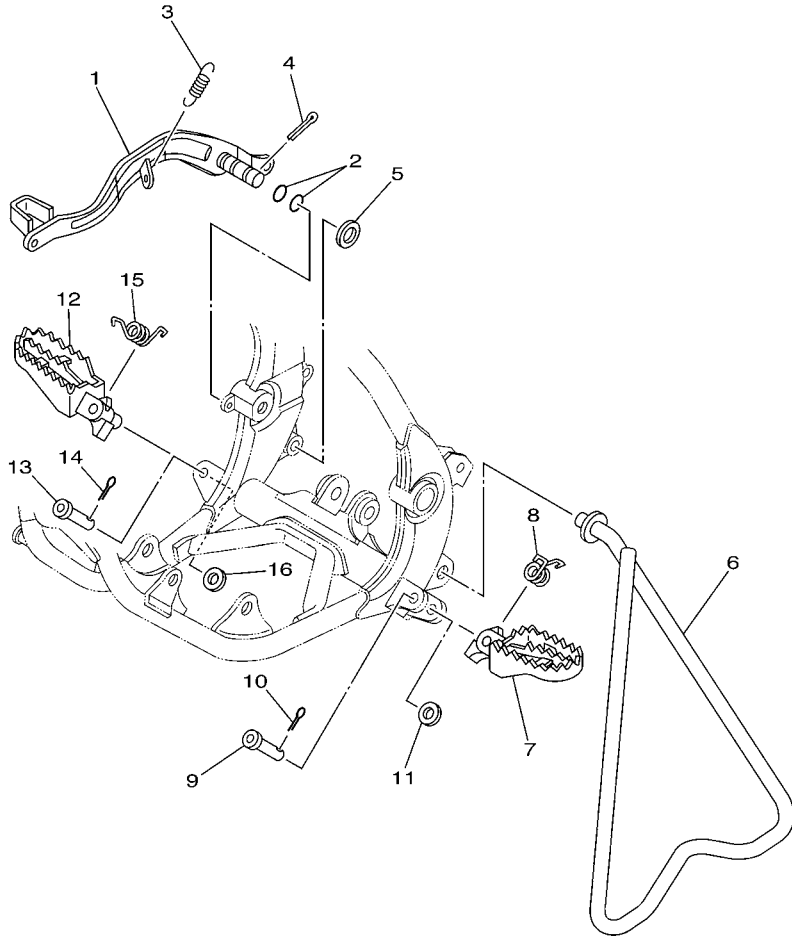

5PA1100-A300

FIG. 30 STAND & FOOTREST

REF. NO.	PART NO.	DESCRIPTION	1SN4	1SN6	1SP4	1SP6	REMARKS
1	5PA-27211-00	PEDAL, BRAKE	1	1	1	1	
2	93210-11073	O-RING	2	2	2	2	
3	90506-15480	SPRING, TENSION	1	1	1	1	
4	91401-20025	PIN, COTTER	1	1	1	1	
5	90201-15700	WASHER, PLATE	1	1	1	1	
6	5PA-27311-00	STAND, SIDE	1	1			
	5SH-27311-00	STAND, SIDE			1	1	
7	5ET-27411-00	FOOTREST 1	1	1	1	1	
8	90508-282B8	SPRING, TORSION	1	1	1	1	
9	90240-10004	PIN, CLEVIS	1	1	1	1	
10	91401-25015	PIN, COTTER	1	1	1	1	
11	90201-10119	WASHER, PLATE	1	1	1	1	
12	5ET-27421-00	FOOTREST 2	1	1	1	1	
13	90240-10004	PIN, CLEVIS	1	1	1	1	
14	91401-25015	PIN, COTTER	1	1	1	1	
15	90508-282B9	SPRING, TORSION	1	1	1	1	
16	90201-10119	WASHER, PLATE	1	1	1	1	

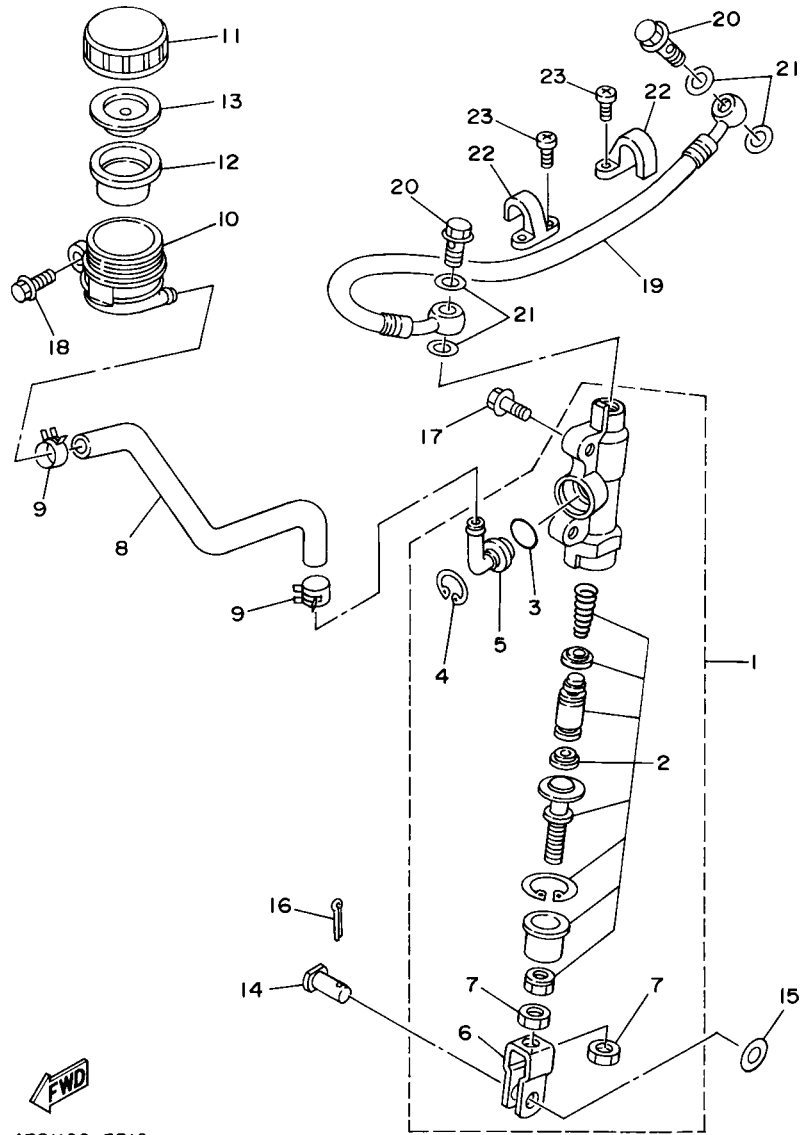

4ES1100-3310

FIG. 31 REAR MASTER CYLINDER

REF. NO.	PART NO.	DESCRIPTION	1SN4	1SN6	1SP4	1SP6	REMARKS
1	4ES-2583V-00	RR. MASTER CYLINDER ASSY.	1	1	1	1	
2	1FK-W0042-50	.CYLINDER KIT, MASTER	1	1	1	1	
3	93210-15620	.O-RING	1	1	1	1	
4	2VN-25866-00	.CIRCLIP	1	1	1	1	
5	2VN-2582A-50	.JOINT	1	1	1	1	
6	2YK-27222-00	.JOINT	1	1	1	1	
7	95307-08600	.NUT	2	2	2	2	
8	4ES-25895-00	HOSE, RESERVOIR	1	1	1	1	
9	90467-11044	CLIP	2	2	2	2	
10	4EW-25894-00	TANK, RESERVOIR	1	1	1	1	
11	3XP-25852-50	CAP, RESERVOIR	1	1	1	1	
12	2VN-25854-00	DIAPHRAGM, RESERVOIR	1	1	1	1	
13	2VN-25855-00	BUSH, DIAPHRAGM	1	1	1	1	
14	90240-08124	PIN, CLEVIS	1	1	1	1	
15	90201-08083	WASHER, PLATE	1	1	1	1	
16	91401-16012	PIN, COTTER	1	1	1	1	
17	95022-06016	BOLT, FLANGE	2	2	2	2	
18	95022-06012	BOLT, FLANGE	1	1	1	1	
19	5PA-25873-01	HOSE, BRAKE 2	1	1			
	5SH-25873-01	HOSE, BRAKE 2			1	1	
20	90401-10168	BOLT, UNION	2	2	2	2	
21	90430-10005	GASKET	4	4	4	4	
22	2VM-25876-00	HOLDER, BRAKE HOSE 2	2	2	2	2	
23	98502-05010	SCREW, PAN HEAD	4	4	4	4	

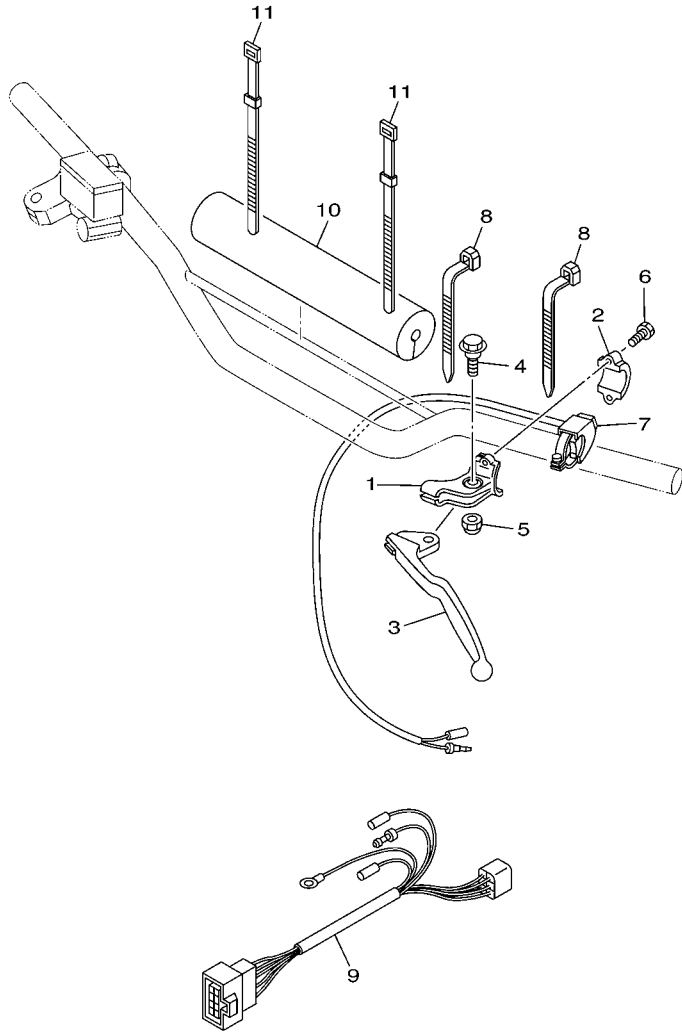

5PAA100-D330

FIG. 33 HANDLE SWITCH & LEVER

REF. NO.	PART NO.	DESCRIPTION	1SN4	1SN6	1SP4	1SP6	REMARKS
1	38V-82911-00	HOLDER, LEVER 1	1	1	1	1	
2	38V-82913-00	HOLDER, LEVER LOWER 1	1	1	1	1	
3	4GY-83912-00	LEVER 1	1	1	1	1	
4	90109-06799	BOLT	1	1	1	1	
5	95607-06100	NUT, U	1	1	1	1	
6	97007-05016	BOLT	2	2	2	2	
7	22W-83976-01	SWITCH, HANDLE 1	1	1	1	1	
8	90464-13077	CLAMP	2	2	2	2	
9	5PA-82509-00	WIRE, SUB LEAD	1	1	1	1	
10	2X1-26124-00	PROTECTOR, HANDLEBAR	1	1	1	1	
11	437-83936-11	BAND, SWITCH CORD	2	2	2	2	

NUMERICAL INDEX

PART NO.	REF. NO.	PART NO.	REF. NO.	PART NO.	REF. NO.	PART NO.	REF. NO.	PART NO.	REF. NO.	PART NO.	REF. NO.
5PA-11111-00	1 - 1	5PA-14392-00	6 - 7	5PA-15651-00	10 - 8	4ES-2153E-20	16 - 15	5PA-22253-00	18 - 34	5PA-23170-00	21 - 10
5PA-11311-20	1 - 8	5PA-14411-10	5 - 16	5PA-15660-00	10 - 1	5PA-21611-10	16 - 7	4AA-22259-40	19 - 5		21 - 30
4ES-11351-00	1 - 9	5PA-14417-00	5 - 22	4ES-15664-00	10 - 6	4ES-21642-00	16 - 12	4AA-22259-50	19 - 5	5PA-23171-00	21 - 4
5PA-11400-00	2 - 1	5PA-14451-00	5 - 17	5PA-16111-00	11 - 1	3RV-21668-A0	18 - 44	4AA-22259-60	19 - 5		21 - 24
5PA-11412-00	2 - 2	5PA-14453-00	5 - 10	5PA-16150-10	11 - 6	3RV-21668-B0	18 - 45	5PA-22475-00	18 - 32	58T-23184-L0	19 - 4
5PA-11422-00	2 - 3	5PA-14458-00	5 - 18	5PA-16181-00	11 - 23	5PA-21711-00	17 - 1	5PA-23102-10	21 - 1	4V4-23188-L0	21 - 18
5PA-11611-00	2 - 10	5PA-14459-00	5 - 11	21V-16321-00	11 - 12	5PA-21721-00	17 - 8	5SH-23102-10	21 - 1		21 - 38
	36 - 3	4ES-14462-00	5 - 12	4ES-16321-00	11 - 11	5PH-2172A-20	17 - 20	5PA-23103-10	21 - 21	4V4-23194-L0	21 - 45
5PA-11630-00	36 - 1	676-14548-00	6 - 20	131-16324-00	11 - 10	5PA-21731-10	17 - 13	5SH-23103-10	21 - 21	5PA-23318-00	21 - 51
5PA-11631-00-A0	2 - 8	4MX-14561-00	6 - 6	2TK-16351-00	11 - 9	5PA-2173E-30	17 - 4	5PA-23110-00	21 - 23	5PA-2331E-10	21 - 43
5PA-11631-00-B0	2 - 8	5PA-14610-00	7 - 1	4ES-16356-00	11 - 17	5PA-2173F-30	17 - 5	4ES-23111-10	21 - 17	5PA-23340-01	21 - 41
	36 - 2	17W-14615-00	7 - 18	5PA-16357-00	11 - 18	1FK-21746-00	17 - 19		21 - 37	5PA-23346-00	21 - 42
5PA-11631-00-C0	2 - 8	5PA-14642-00	7 - 7	5PA-16371-10	11 - 8	5PA-21748-00	17 - 15	5PA-23120-00	21 - 3	3XJ-23357-L0	21 - 14
5PA-11631-00-D0	2 - 8	4ES-1469A-00	7 - 12	4ES-16381-00	11 - 22	1SN-2174G-10	17 - 16	5PA-23125-00	21 - 5		21 - 34
4ES-11633-00	2 - 9	4ES-14753-20	7 - 11	4ES-17121-01	12 - 5	5PA-22110-00	18 - 1		21 - 25	4DA-23389-00	20 - 4
	36 - 4	565-14771-00	7 - 9	4ES-17131-03	12 - 3	5SH-22110-10	18 - 1	3JD-2312G-L0	21 - 20	3JD-23394-00	21 - 19
4ES-11650-10	36 - 6	5PA-14916-KE	6 - 9	4ES-17151-10	12 - 2	5PA-22128-00	18 - 15		21 - 40		21 - 39
4ES-11651-10	2 - 4	5PA-14916-KF	6 - 9	4ES-17161-10	12 - 4	4ES-22129-00	18 - 23	5PA-23136-10	21 - 2	1J7-23415-00	20 - 3
	36 - 7	5PA-14916-KG	6 - 9	4ES-17211-01	12 - 17	5PA-22151-00	18 - 11		21 - 22	4ES-23435-00	20 - 9
2RA-11681-00	2 - 6	5PA-14916-LE	6 - 9	5PA-17221-00	12 - 12	5PA-22176-00	18 - 31	4LB-23141-10	21 - 15	3SP-23441-00	20 - 11
	36 - 9	5PA-14916-LF	6 - 9	4ES-17231-10	12 - 14	30X-22178-00	15 - 8		21 - 35	4ES-23485-00	20 - 13
4BA-12422-00	3 - 9	5PA-14916-LG	6 - 9	5PA-17241-00	12 - 15	4ES-22178-00	15 - 12	4ES-23141-40	21 - 15	5PA-24110-30	22 - 1
4BA-12428-00	3 - 10	4MX-14919-00	6 - 10	4ES-17251-00	12 - 16	5PA-2217A-00	18 - 20		21 - 35	4EW-2412F-00	22 - 7
5PA-12451-00	3 - 4	5HC-14922-00	6 - 23	5PA-17261-01	12 - 13	4ES-2217F-00	18 - 35		35 - 2	3HA-24141-00	15 - 17
5PA-12459-00	3 - 1	5HC-14934-00	6 - 24	5PA-17411-00	12 - 1	4V4-22184-00	15 - 9	4ES-23141-50	35 - 2	5XE-24144-00	22 - 2
5PA-12461-00	4 - 1	4MX-14943-34	6 - 22	5PA-17421-00	12 - 11	5PA-22184-00	18 - 33	4ES-23141-60	35 - 2	3XJ-2415E-A1	16 - 4
22W-12462-00	4 - 2	4MX-14943-35	6 - 22	164-17427-00-06	12 - 21	5PA-22199-00	18 - 14	4ES-23141-70	35 - 2	3XJ-2415E-B1	16 - 5
22W-12463-00	4 - 3	4MX-14943-85	6 - 22	164-17427-00-08	12 - 21	5SH-22201-40	19 - 2	4ES-23142-00	21 - 13	3XJ-2415E-C1	16 - 4
4ES-12481-10	4 - 5	5PA-14947-00	6 - 30	164-17427-00-10	12 - 21	5SH-22201-50	19 - 2		21 - 33	4SR-2416E-00	16 - 6
5PA-12482-00	4 - 7	4MX-14948-04	6 - 8	5PA-18101-00	14 - 1	5PA-22201-70	19 - 2	4ES-23144-00	21 - 9	5PA-24181-00	22 - 26
353-13115-01	8 - 8	4MX-14948-05	6 - 8	2HF-18110-02	14 - 9	5PA-22201-80	19 - 2		21 - 29	5PA-24182-00	22 - 20
5PA-13565-00	5 - 6	4MX-14948-06	6 - 8	5PA-1811E-00	14 - 6	5SH-22210-40	19 - 1	4ES-23145-00	21 - 7	1SN-24240-10	22 - 22
4ES-13610-00	5 - 1	5PA-1496A-00	6 - 29	5PA-18140-00	14 - 7	5SH-22210-50	19 - 1		21 - 27	5PA-24311-00	22 - 23
4ES-13613-00	5 - 2	5PA-14984-00	6 - 4	4ES-18511-02	13 - 2	5PA-22210-70	19 - 1	5K5-23149-00	21 - 6	3XJ-24380-00	22 - 11
4ES-13616-00	5 - 3	5PA-14985-00	6 - 3	5R2-18512-00	13 - 3	5PA-22210-80	19 - 1		21 - 26	4DP-24500-10	22 - 13
5PA-14101-00	6 - 1	5PA-15111-00	8 - 1	4ES-18513-01	13 - 4	4ES-22212-F0	19 - 6	5PA-23149-00	21 - 16	4X8-24512-10	22 - 16
5PA-14105-00	6 - 13	5PA-15118-00	8 - 10	4BA-18531-00	13 - 6		35 - 1		21 - 36	3AC-24523-00	22 - 17
5PA-1410E-00	6 - 18	5PA-15121-10	8 - 2	4BA-18535-00	13 - 7		35 - 1	4ES-2314F-00	21 - 44	3AJ-24534-10	22 - 14
4MX-14115-00	6 - 5	3Y1-15363-10	9 - 11	4ES-18540-00	13 - 1	4ES-22212-G0	19 - 6	5PA-2314H-L0	21 - 46	5NY-24610-10	22 - 9
5PA-14126-00	6 - 12	4ES-15411-00	9 - 1	5PA-21101-12-33	15 - 1		35 - 1	5PA-2314J-L0	21 - 47	5PA-2470F-20	23 - 2
5PA-14131-00	6 - 14	5PA-15415-10	9 - 13	5PA-2118K-00	16 - 14	4ES-22212-H0	19 - 6	4A1-23156-00	21 - 8	5PA-24718-00	23 - 3
3TJ-14137-40	6 - 21	5PA-15431-00	9 - 4	5PA-2118K-10	16 - 16		35 - 1		21 - 28	5PA-24728-00	23 - 4
5PA-14146-00	6 - 28	5PA-15451-00	9 - 3	5PA-2118K-20	16 - 14	4ES-22212-J0	35 - 1	2HH-23158-L0	21 - 12	5PA-24770-30	23 - 1
5PA-14159-00	6 - 15	4ES-15461-00	9 - 5	5PA-21190-00-33	15 - 2	4ES-22212-K0	35 - 1		21 - 32	4LB-25104-00	24 - 9
4JT-14171-00	6 - 2	5PA-15463-00	9 - 14	5PA-21274-10	15 - 15	3JD-22214-00	19 - 8	5PA-2316A-00	21 - 11	4ES-25104-20	24 - 9
5PA-14194-00	6 - 25	5PA-15620-01	10 - 11	4ES-21511-20	16 - 1	4ES-22214-00	19 - 7		21 - 31	4ES-25111-00	24 - 1
4XL-14197-10	6 - 19	5PA-15621-00	10 - 12	4XL-2153A-10	21 - 49	4ES-22216-00	19 - 3	5SH-2316A-00	21 - 11	4ES-25181-00	24 - 11
5PA-14340-00	6 - 11	5PA-15641-00	10 - 2		21 - 50	4ES-22251-00	19 - 9		21 - 31	22W-25181-01	18 - 2

NUMERICAL INDEX

PART NO.	REF. NO.	PART NO.	REF. NO.	PART NO.	REF. NO.	PART NO.	REF. NO.	PART NO.	REF. NO.	PART NO.	REF. NO.
4ES-25183-10	24 - 14	56A-25919-10	25 - 10	4ES-W0047-10	25 - 5	90159-06021	17 - 18	90208-12015	11 - 4	90445-08376	8 - 9
1T1-25194-00	24 - 10	1UY-25919-51	27 - 6	51L-W0048-00	25 - 8	90159-06182	17 - 17		11 - 15	90445-09003	22 - 10
4LB-25304-00	26 - 11	4ES-25920-00	27 - 14	1UY-W0048-50	27 - 7	90176-08005	1 - 6	90209-06015	16 - 3	90445-09005	22 - 12
4ES-25304-20	26 - 11	56A-25926-00	25 - 12	4ES-W0057-10	25 - 4	90179-08019	1 - 13	90209-06096	5 - 19	90450-25037	4 - 6
4ES-25311-00	26 - 1	3GD-25933-00	27 - 10	4EW-W0057-50	27 - 4	90179-08148	28 - 15	90209-14008	12 - 7	90450-28014	4 - 8
4ES-25381-01	26 - 17	56A-25937-00	25 - 7	5XE-W2587-00	29 - 4	90179-12007	11 - 5	90209-16209	12 - 18	90450-41001	5 - 8
4ES-25383-00	26 - 2	5R2-25937-00	25 - 6	90101-08060	26 - 21		11 - 16	90209-20159	2 - 7	90450-99064	5 - 15
4ES-25383-10	26 - 23	1UY-25937-51	27 - 12	90101-12755	18 - 39	90179-16226	12 - 31		36 - 10	90460-15126	34 - 3
5PA-25388-00	26 - 19	5PA-26111-00	28 - 1	90105-06078	27 - 18	90179-22025	20 - 7	90215-20261	12 - 30	90460-56071	5 - 9
1T2-25394-00	26 - 12	2X1-26124-00	33 - 10	90105-06180	34 - 5	90179-25004	20 - 6	90240-08124	31 - 14	90461-10136	8 - 12
5X2-25394-00	26 - 12	4GY-26241-00	28 - 4	90105-08126	8 - 11	90183-060A7	16 - 11	90240-10004	30 - 9	90464-13077	4 - 12
5PA-25446-00	26 - 13	4GY-26242-00	28 - 2	90105-08211	25 - 14	90185-08008	26 - 15		30 - 13		33 - 8
4ES-25447-20	26 - 13	22W-26243-00	28 - 3	90105-10219	15 - 6	90185-10018	19 - 12	90250-06013	13 - 5	90464-25004	32 - 6
5PA-25448-00	26 - 13	5X2-26281-00	28 - 5	90105-10220	15 - 5	90185-12010	24 - 12	90267-48138	5 - 13	90465-13275	22 - 21
5PA-25449-00	26 - 13	322-26282-00	28 - 6	90105-10582	18 - 24	90185-12011	18 - 40	90280-03045	2 - 13	90467-08002	4 - 4
5PA-25451-00	26 - 13	5X2-2628H-01	28 - 7	90105-10614	19 - 13	90185-14012	26 - 18	90282-05001	11 - 3	90467-09002	22 - 25
5PA-25452-00	26 - 13	5PA-26311-00	28 - 11	90109-065F3	5 - 21	90201-043H7	5 - 14	90336-06031	10 - 17	90467-10008	22 - 24
5PA-25453-00	26 - 13	4ES-26335-11	28 - 12	90109-06799	33 - 4	90201-06060	10 - 19	90338-10150	18 - 43	90467-11044	31 - 9
5CG-25715-00	29 - 10	498-26372-00	28 - 13	90109-08718	27 - 16		12 - 9	90380-10218	18 - 22	90468-23194	10 - 3
5PA-2580T-00	25 - 3	5NY-26372-00	29 - 17	90109-10729	19 - 10	90201-06086	7 - 5	90380-12219	18 - 28	90480-15528	4 - 10
5PA-2580W-00	27 - 3	4ES-27114-00	29 - 19	90109-12015	18 - 29	90201-06089	7 - 14	90381-12091	18 - 38	90480-16561	7 - 15
3GD-25827-00	27 - 9	5PA-27211-00	30 - 1	90111-08029	15 - 3	90201-08043	26 - 16	90385-17042	18 - 5	90480-18411	7 - 3
2VN-2582A-50	31 - 5	2YK-27222-00	31 - 6		27 - 15	90201-08078	15 - 10	90387-06009	17 - 2	90480-18549	22 - 4
5PA-2582T-00	25 - 1	5PA-27311-00	30 - 6	90116-08027	1 - 5	90201-08083	31 - 15		17 - 9	90501-12081	10 - 13
5PA-2582W-00	27 - 1	5SH-27311-00	30 - 6	90116-08028	1 - 11	90201-080L8	1 - 7		17 - 14	90501-204A0	11 - 13
5MV-25833-00	29 - 16	5ET-27411-00	30 - 7	90116-08031	1 - 10	90201-08512	3 - 2	90387-06027	22 - 5	90506-15480	30 - 3
4ES-2583V-00	31 - 1	5ET-27421-00	30 - 12	90119-05001	11 - 14		3 - 5	90387-0614M	4 - 11	90507-20052	7 - 8
5MV-25852-01	29 - 8	5PA-27491-00	27 - 17	90119-06133	16 - 8	90201-10119	30 - 11	90387-06168	7 - 16	90508-14016	11 - 25
3XP-25852-50	31 - 11	5PG-2816R-00	16 - 14	90119-06159	15 - 13		30 - 16	90387-06180	18 - 13	90508-24007	14 - 3
5XE-25853-00	29 - 11	5PA-82310-00	34 - 4	90119-06181	4 - 9	90201-10591	32 - 5	90387-064X4	16 - 9	90508-26750	10 - 5
2VN-25854-00	31 - 12	8DG-82370-00	34 - 6	90119-06190	22 - 6	90201-11016	19 - 14	90387-067K6	15 - 14	90508-282B8	30 - 8
5XE-25854-00	29 - 7	5PA-82509-00	33 - 9	90119-06201	16 - 2	90201-12032	18 - 4	90387-0701A	16 - 10	90508-282B9	30 - 15
2VN-25855-00	31 - 13	38V-82911-00	33 - 1	90119-06217	7 - 10	90201-12047	18 - 41	90387-1001B	17 - 3	90508-32016	14 - 2
2VN-25866-00	31 - 4	38V-82913-00	33 - 2		17 - 7	90201-12049	18 - 42		17 - 10	91401-16012	31 - 16
5MV-25867-00	29 - 15	4GY-83912-00	33 - 3		17 - 12	90201-12055	24 - 13	90387-105L0	7 - 4	91401-20025	30 - 4
5NY-25868-00	29 - 6	5MV-83922-00	29 - 12	90119-06239	16 - 13	90201-124F8	10 - 9	90387-1200U	18 - 9	91401-25015	30 - 10
5SH-25872-01	29 - 1	437-83936-11	33 - 11	90119-06240	17 - 6	90201-15027	26 - 20	90387-124H0	24 - 2		30 - 14
4ES-25872-11	29 - 1	22W-83976-01	33 - 7		17 - 11	90201-15700	30 - 5	90387-127J7	18 - 8	92012-06010	7 - 13
5PA-25873-01	31 - 19	1SP-85540-00	34 - 1	90122-06010	5 - 20	90201-171G6	11 - 24	90387-127J8	18 - 7	92012-06040	18 - 16
5SH-25873-01	31 - 19	5PA-85540-00	34 - 1	90123-08046	28 - 14	90201-17545	12 - 8	90387-202A0	12 - 29	92902-03100	5 - 5
2VM-25876-00	31 - 22	5PA-85546-00	34 - 2	90149-06108	22 - 19	90201-17558	11 - 7	90387-20488	11 - 2	92902-10600	19 - 11
4EW-25894-00	31 - 10	4SS-85550-11	32 - 2		32 - 3	90201-176L4	10 - 4	90387-227H7	28 - 10	92903-04600	6 - 17
4ES-25895-00	31 - 8	5PA-85560-01	32 - 1	90149-06327	25 - 2	90201-177G4	14 - 5	90401-10168	29 - 3		6 - 27
5MV-2589F-00	29 - 13	5NY-W0041-01	29 - 5		27 - 2	90201-20611	12 - 20		31 - 20	92907-06100	23 - 6
34X-25914-00	25 - 13	1FK-W0042-50	31 - 2	90151-06045	10 - 15	90201-220T0	20 - 8	90430-06166	3 - 11	93101-12173	14 - 8
3GD-25916-00	27 - 13	5PA-W0045-00	25 - 11	90152-08001	26 - 14	90201-256K5	20 - 2	90430-08119	9 - 10	93101-17062	18 - 27
1UY-25917-51	27 - 11	5PA-W0046-50	27 - 8	90157-05029	20 - 5	90201-33299	7 - 2	90430-10005	29 - 2		18 - 37
56A-25919-00	25 - 9	4ES-W0047-00	27 - 5	90157-06008	12 - 10	90202-05193	22 - 18		31 - 21	93102-12106	3 - 7

NUMERICAL INDEX

PART NO.	REF. NO.	PART NO.	REF. NO.	PART NO.	REF. NO.	PART NO.	REF. NO.	PART NO.	REF. NO.	PART NO.	REF. NO.
93102-12224	11 - 21	94107-19015	24 - 5	95602-12200	18 - 30						
93102-17263	10 - 7	94109-14012	26 - 7	95607-06100	33 - 5						
93102-20009	26 - 5	94109-14015	26 - 7	95612-12100	18 - 3						
93102-20447	2 - 17	94109-16012	26 - 7	95701-06500	29 - 14						
93102-26042	12 - 27	94109-16015	26 - 7	95802-08035	20 - 10						
93102-28009	2 - 16	94207-17284	24 - 6	95812-08125	15 - 4						
93106-20031	24 - 4	94207-19290	24 - 6	95822-06010	4 - 13						
93109-11073	3 - 6	94208-14285	26 - 8	95822-06060	3 - 12						
93109-17071	18 - 10	94209-16291	26 - 8	97007-05016	33 - 6						
93210-11073	30 - 2	94307-16171	26 - 9	97007-06012	23 - 5						
93210-12152	10 - 16	94307-17166	24 - 7	97022-06020	14 - 10						
93210-15620	31 - 3	94307-19170	24 - 7	98502-03006	5 - 4						
93210-19123	9 - 12	94308-14165	26 - 9	98502-05010	31 - 23						
93210-56459	1 - 3	94414-17530	24 - 8	98502-05016	28 - 9						
93210-84724	1 - 4	94414-19521	24 - 8	98502-06030	9 - 2						
93306-00105	3 - 8	94416-14529	26 - 10	98502-06040	8 - 4						
93306-00203	26 - 3	94418-16522	26 - 10	98502-06050	8 - 5						
93306-20120	24 - 3	94682-00001	26 - 25	98502-06060	8 - 6						
93306-20203	26 - 4	94702-00368	1 - 2	98502-06070	8 - 7						
93306-20333	12 - 23	94709-00368	1 - 2	98504-04012	6 - 26						
93306-20401	12 - 26	95022-06012	10 - 18	98504-04014	6 - 16						
93306-20438	2 - 14		15 - 16	98507-03008	22 - 15						
93306-30421	2 - 15		20 - 14	98702-04012	28 - 8						
93310-21417	2 - 12		31 - 18	98702-06025	22 - 8						
	36 - 11	95022-06014	18 - 12	98706-04012	29 - 9						
93310-420B1	2 - 5	95022-06016	31 - 17	99009-10400	13 - 8						
	36 - 8	95022-06020	5 - 7	99009-12400	10 - 10						
93315-11206	11 - 20		21 - 52	99009-17400	14 - 4						
93315-21455	18 - 21	95022-06025	3 - 13	99009-35500	26 - 6						
93315-31502	12 - 25		7 - 6	99530-08016	9 - 15						
93317-11245	12 - 24		7 - 17	99530-10014	8 - 3						
93317-21746	18 - 6		9 - 16		9 - 6						
93317-31771	18 - 26	95022-06030	9 - 7	99590-10114	1 - 12						
	18 - 36	95022-06035	9 - 17	9Y582-00117	26 - 24						
93332-00079	20 - 1	95022-06040	9 - 8	9Y582-00123	26 - 24						
93410-20038	12 - 19	95022-08012	15 - 11								
93440-07182	3 - 3	95022-08030	20 - 12								
93440-15012	12 - 22	95022-08050	18 - 18								
93440-17064	12 - 6	95022-08080	9 - 9								
93450-16115	2 - 11	95024-06010	21 - 48								
	36 - 5	95027-06016	22 - 3								
93503-16003	11 - 19	95302-08700	26 - 22								
93507-32009	10 - 14	95307-08600	31 - 7								
9382A-14227	12 - 28	95312-10600	32 - 4								
9382A-15228	12 - 28	95602-06200	18 - 17								
94107-17012	24 - 5	95602-08200	18 - 19								
94107-17019	24 - 5	95602-10200	15 - 7								
94107-19012	24 - 5		18 - 25								