



PARTS CATALOGUE

YFM125GB (1PY2) CANADA

YFM125GB (1PY3) EUROPE

YFM125G (1PY1) JAPAN

YFM125GB/YFM125G
PARTS CATALOGUE
©2011 by Yamaha Motor Co., Ltd.
1st edition, April 2011
All rights reserved.
Any reprinting or unauthorized use
without the written permission of
Yamaha Motor Co., Ltd.
is expressly prohibited.
Printed in Japan.

FOREWORD

This Parts Catalogue is related to the parts for the model(s) on the cover page. When you are ordering replacement parts, please refer to this Parts Catalogue and quote both part numbers and part names correctly.

1. Modifications or additions which have been made after the issue of the Parts Catalogue will be announced in the Parts News.

It is advisable that you make the necessary corrections to the Parts Catalogue according to the Parts News.

2. Abbreviations

The following abbreviations are used in this Parts Catalogue.

“UR” Use specified parts number.

“UN” Use as many as needed.

“AP” Alternate Parts

“LM” Locally Made (Parts need to be ordered locally)

“F#” Frame No. (Applicable machine No.)

“O/S” Over Size

3. The number of components for assembly

- Parts, which are to be supplied in an assembly, are listed with a dot (.) in front of the part name as shown below.
- The numeral appearing to the right of each component part indicates the quantity of parts for each assembly unit.

PART NO.	DESCRIPTION	Q'TY	REMARKS
2F5-83310-60	FRONT FLASHER LIGHT ASSY	2	
115-83311-60	.BULB (6V-18W)	1	

4. Applicable colours of graphics are represented in the “REMARKS” as shown below.

PART NO.	DESCRIPTION	Q'TY	REMARKS
2N4-24110-00-X5	FUEL TANK COMP.	2	MXR
3J1-24240-10	.GRAPHIC, FUEL TANK	1	FOR MXR

5. Note that the illustrations for reference in finding parts numbers are not to be used for assembling. When assembling, please use the applicable service manual.

6. The asterisk (*) before a reference number indicates modified items after the first edition.

FOREWORD

7. Applicable Serial No.

Engine Serial No.

Frame Serial No.

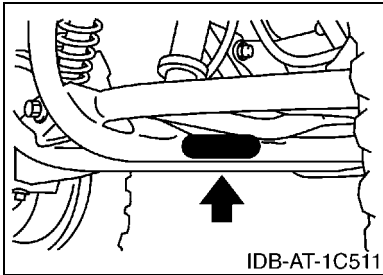
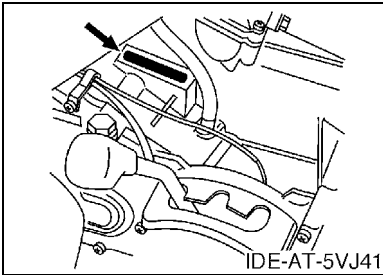

8. Applicable Colour Code (The (*) mark shows Model colour.)

Abbreviation	Colour Name	Colour Code
DPBSN(*)	DARK PURPLISH BLUE SOLID N	0891
LGB	LOW GLOSS BLACK	0098
YB	YAMAHA BLACK	0033

9. Quantity Column Information

Column No.	Name Of Q'ty Column	Destination
1	CAN	CANADA
2	EUR	EUROPE
3	JPN	JAPAN

CONTENTS

ENGINE

CYLINDER HEAD	1
CRANKSHAFT & PISTON	2
VALVE	3
CAMSHAFT & CHAIN	4
OIL PUMP	5
INTAKE	6
CARBURETOR	7
EXHAUST	9
CRANKCASE	10
CRANKCASE COVER 1	12
STARTER CLUTCH	13
CLUTCH	14
TRANSMISSION	16
SHIFT CAM & FORK	18

CHASSIS

FRAME	19
FRONT FENDER	20
REAR FENDER	21
REAR ARM & SUSPENSION	22
STEERING	23
FRONT SUSPENSION & WHEEL	24
FUEL TANK	25
SEAT	26
FRONT WHEEL	27
REAR WHEEL	29
STEERING HANDLE & CABLE	31
STAND & FOOTREST	33
GUARD	34
GENERATOR	35
STARTING MOTOR	36
HEADLIGHT	37
TAILLIGHT	38
HANDLE SWITCH & LEVER	39
ELECTRICAL 1	40
ELECTRICAL 2	42
EMBLEM & LABEL 1	43
EMBLEM & LABEL 2	45
EMBLEM & LABEL 3	46

INDEX

NUMERICAL INDEX	47
-----------------------	----

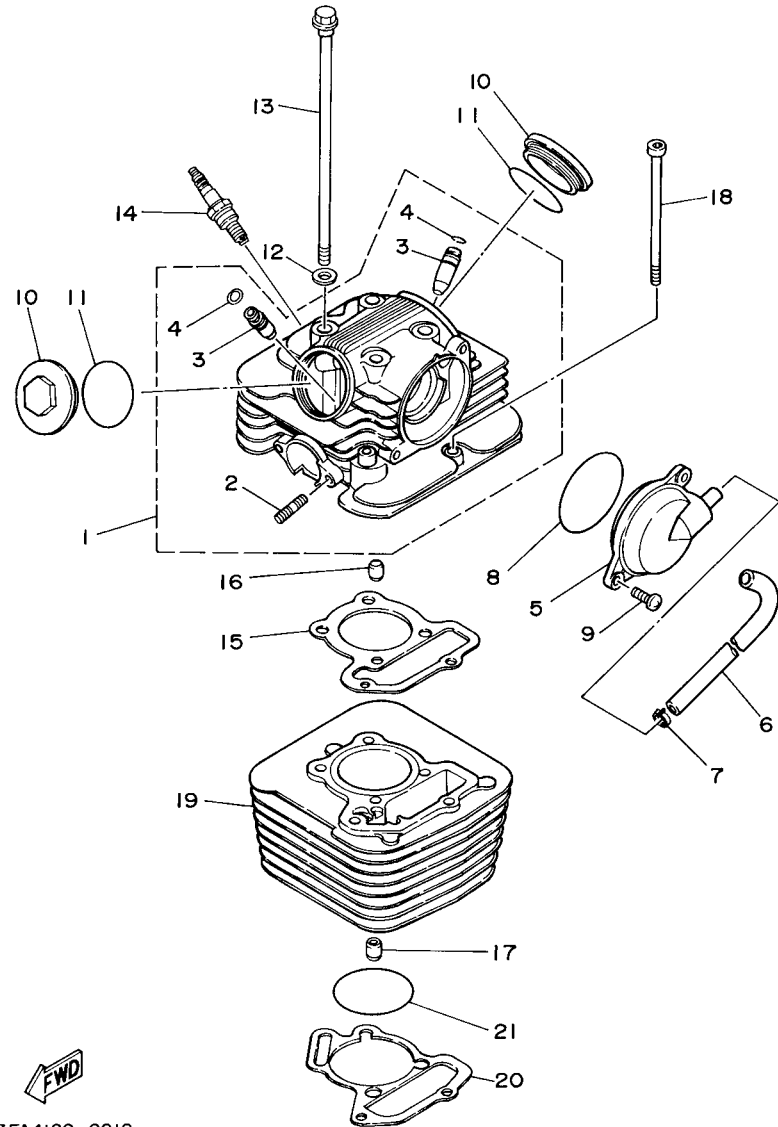

3FA4100-0010

FIG. 1 CYLINDER HEAD

REF. NO.	PART NO.	DESCRIPTION	CAN	EUR	JPN	REMARKS
1	3FA-11102-04	CYLINDER HEAD ASSY	1	1	1	
2	90116-06541	.BOLT, STUD	2	2	2	
3	22F-11134-10	.GUIDE, VALVE 2	2	2	2	
4	93440-10109	.CIRCLIP	2	2	2	
5	3FA-11160-00	BREATHER ASSY	1	1	1	
6	3FA-11166-00	PIPE, BREATHER 1	1	1	1	
7	90467-13064	CLIP	1	1	1	
8	93210-63556	O-RING	1	1	1	
9	98502-06016	SCREW, PAN HEAD	2	2	2	
10	22F-11186-10	COVER, CYLINDER HEAD SIDE 2	2	2	2	
11	93210-44704	O-RING	2	2	2	
12	90201-08609	WASHER, PLATE	4	4	4	
13	90105-08181	BOLT, FLANGE	4	4	4	
14	94701-00366	PLUG, SPARK (NGK CR7HSA)	1	1		
	94703-00366	PLUG, SPARK (NGK CR7HSA)			1	
15	50M-11181-00	GASKET, CYLINDER HEAD 1	1	1	1	
16	99530-10114	PIN, DOWEL	2	2	2	
17	99530-10114	PIN, DOWEL	2	2	2	
18	91312-06110	BOLT	2	2	2	
19	3FA-11310-00	CYLINDER	1	1	1	
20	3FA-11351-10	GASKET, CYLINDER	1	1	1	
21	93210-53679	O-RING	1	1	1	

FIG. 2 CRANKSHAFT & PISTON

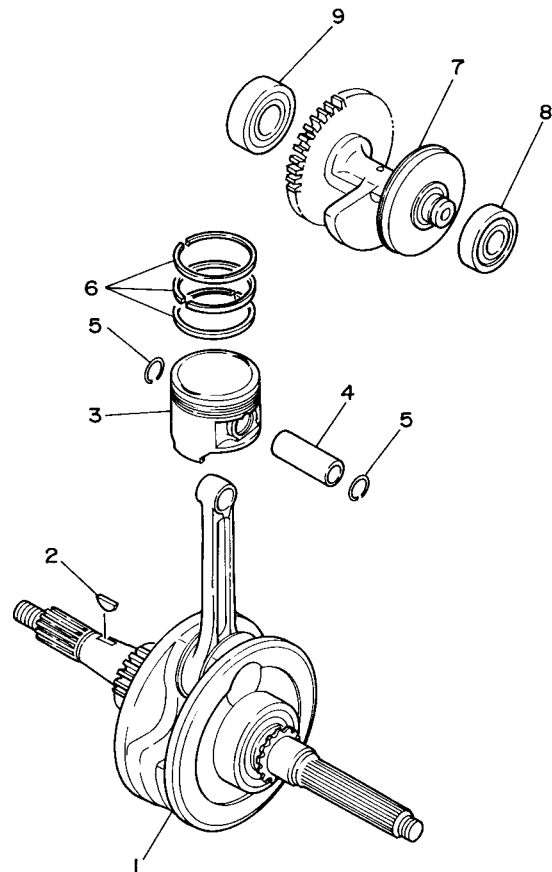

3FA1110-9020

REF. NO.	PART NO.	DESCRIPTION	CAN	EUR	JPN	REMARKS
1	3FA-11400-00	CRANKSHAFT ASSY	1	1	1	
2	90280-03047	KEY, WOODRUFF	1	1	1	
3	3FA-11631-00-A0	PISTON (STD)	1	1	1	
	3FA-11636-00	PISTON (0.50MM O/S)	1	1	1	AP
	3FA-11638-00	PISTON (1.00MM O/S)	1	1	1	AP
4	22K-11633-01	PIN, PISTON	1	1	1	
5	93450-14088	CIRCLIP	2	2	2	
6	2HX-11610-00	PISTON RING SET (STD)	1	1	1	
	2HX-11610-20	PISTON RING SET (0.50MM O/S)	1	1	1	AP
	2HX-11610-40	PISTON RING SET (1.00MM O/S)	1	1	1	AP
7	3FA-11500-00	BALANCER ASSY	1	1	1	
8	93306-20215	BEARING	1	1	1	
9	93306-20336	BEARING	1	1	1	

FIG. 3 VALVE

REF. NO.	PART NO.	DESCRIPTION	CAN	EUR	JPN	REMARKS
1	5AP-12111-01	VALVE, INTAKE	1	1	1	
2	5HP-12121-00	VALVE, EXHAUST	1	1	1	
3	2HX-12119-00	SEAL, VALVE STEM	2	2	2	
4	22F-12116-00	SEAT, VALVE SPRING	2	2	2	
5	3FA-12113-00	SPRING, VALVE INNER	2	2	2	
6	22F-12118-01	COTTER, VALVE	4	4	4	
7	22F-12117-02	RETAINER, VALVE SPRING	2	2	2	
8	50M-12151-00	ARM, VALVE ROCKER	2	2	2	
9	22F-12159-00	SCREW, VALVE ADJUSTING	2	2	2	
10	90170-05302	NUT	2	2	2	
11	22F-12156-00	SHAFT, ROCKER 2	2	2	2	

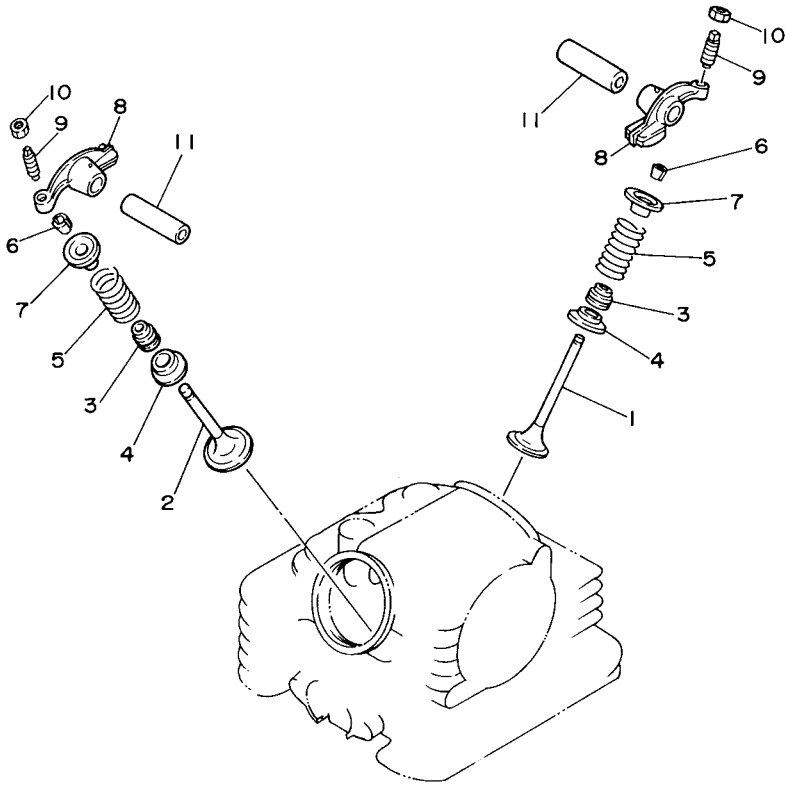

FWD
3FA1110-9030

FIG. 4 CAMSHAFT & CHAIN

REF. NO.	PART NO.	DESCRIPTION	CAN	EUR	JPN	REMARKS
1	50M-12170-01	CAMSHAFT ASSY 1	1	1	1	
2	50M-12176-00	SPROCKET, CAM CHAIN (28T)	1	1	1	
3	90387-167L5	COLLAR	1	1	1	
4	3FA-11145-00	PLATE, BREATHER 2	1	1	1	
5	90201-08048	WASHER, PLATE	1	1	1	
6	90101-08055	BOLT	1	1	1	
7	94580-25092	CHAIN (D.I.D 25)	1	1	1	
8	50M-12231-00	GUIDE, STOPPER 1	1	1	1	
9	50M-12241-00	GUIDE, STOPPER 2	1	1	1	
10	50M-12210-00	TENSIONER ASSY, CAM CHAIN	1	1	1	
11	4RF-12213-00	GASKET, TENSIONER CASE	1	1	1	
12	91312-06016	BOLT	2	2	2	
13	90430-06014	GASKET	1	1	1	
14	4GL-11111F-00	PLATE	1	1	1	
15	91312-06012	BOLT	1	1	1	

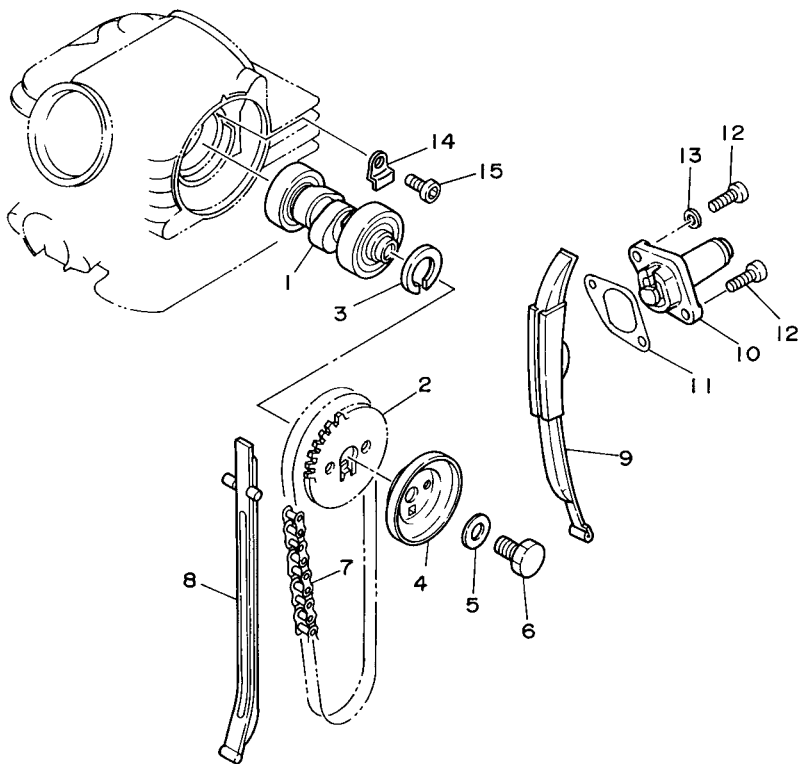

1C55100-D040

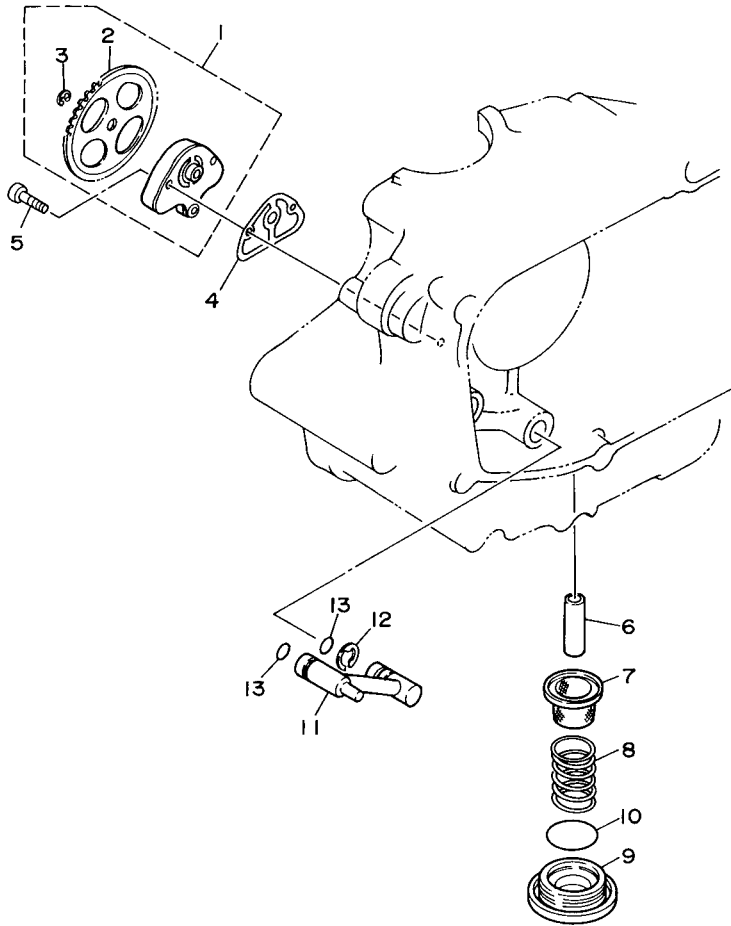

3FA1110-9050

FIG. 5 OIL PUMP

REF. NO.	PART NO.	DESCRIPTION	CAN	EUR	JPN	REMARKS
1	3FA-13300-00	OIL PUMP ASSY	1	1	1	
2	3FA-13325-00	.GEAR, PUMP DRIVEN	1	1	1	
3	99001-05600	.CIRCLIP	1	1	1	
4	22F-13329-01	GASKET, PUMP COVER	1	1	1	
5	90155-06001	SCREW, FLAT FILLISTER	2	2	2	
6	3Y1-13416-01	PIPE, OIL 1	1	1	1	
7	51Y-13411-00	STRAINER, OIL	1	1	1	
8	90501-18576	SPRING, COMPRESSION	1	1	1	
9	30X-15351-00	PLUG, DRAIN	1	1	1	
10	93210-347A1	O-RING	1	1	1	
11	3FA-13405-00	OIL PIPE COMP. 1	1	1	1	
12	99001-10600	CIRCLIP	1	1	1	
13	93210-08006	O-RING	2	2	2	

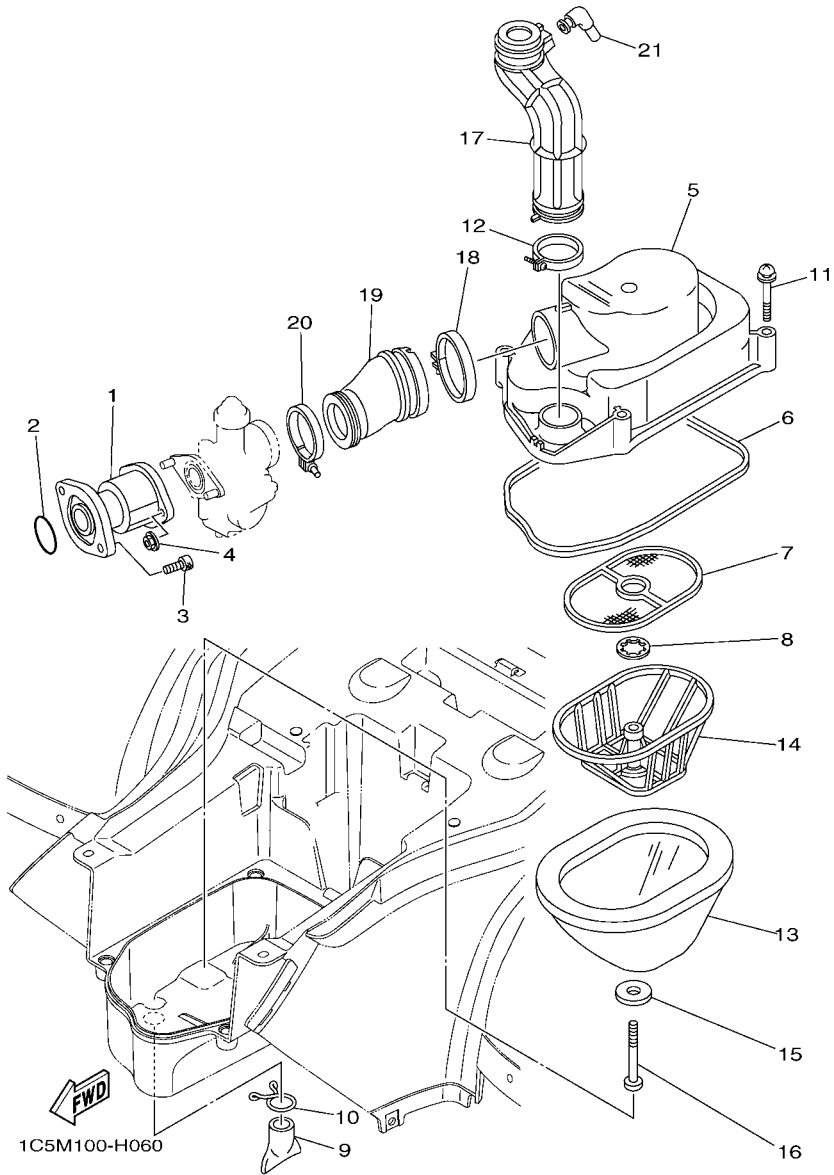

1C5M100-H060

FIG. 6 INTAKE

REF. NO.	PART NO.	DESCRIPTION	CAN	EUR	JPN	REMARKS
1	3FA-13586-00	JOINT, CARBURETOR 1	1	1	1	
2	93210-30611	O-RING	1	1	1	
3	91312-06020	BOLT	2	2	2	
4	95702-06500	NUT, FLANGE	2	2	2	
5	3FA-14412-01	CAP, CLEANER CASE 1	1	1	1	
6	36F-14452-00	SEAL	1	1	1	
7	3FA-14472-00	PLATE, ELEMENT	1	1	1	
8	3FA-14424-00	CLIP, CAP FITTING	1	1	1	
9	59V-14457-00	SEAL	1	1	1	
10	90467-220A1	CLIP	1	1	1	
11	90159-05045	SCREW, WITH WASHER	4	4	4	
12	90450-45075	HOSE CLAMP ASSY	1	1	1	
13	2XJ-14451-00	ELEMENT, AIR CLEANER	1	1	1	
14	2XJ-14458-00	GUIDE	1	1	1	
15	90209-06096	WASHER	1	1	1	
16	98502-06060	SCREW, PAN HEAD	1	1	1	
17	3FA-14437-00	DUCT	1	1	1	
18	90460-58015	CLAMP, HOSE	1	1	1	
19	3FA-14453-00	JOINT, AIR CLEANER 1	1	1	1	
20	90450-45075	HOSE CLAMP ASSY	1	1	1	
21	2NL-14419-00	PIPE	1	1	1	

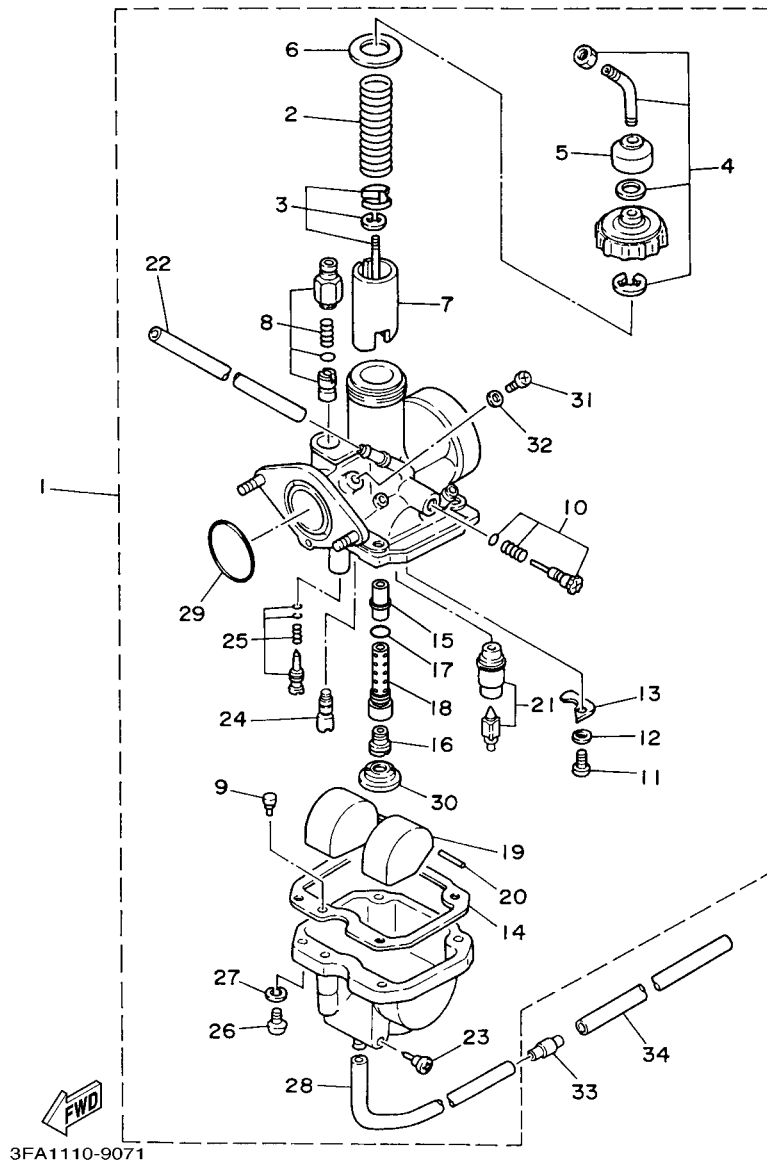
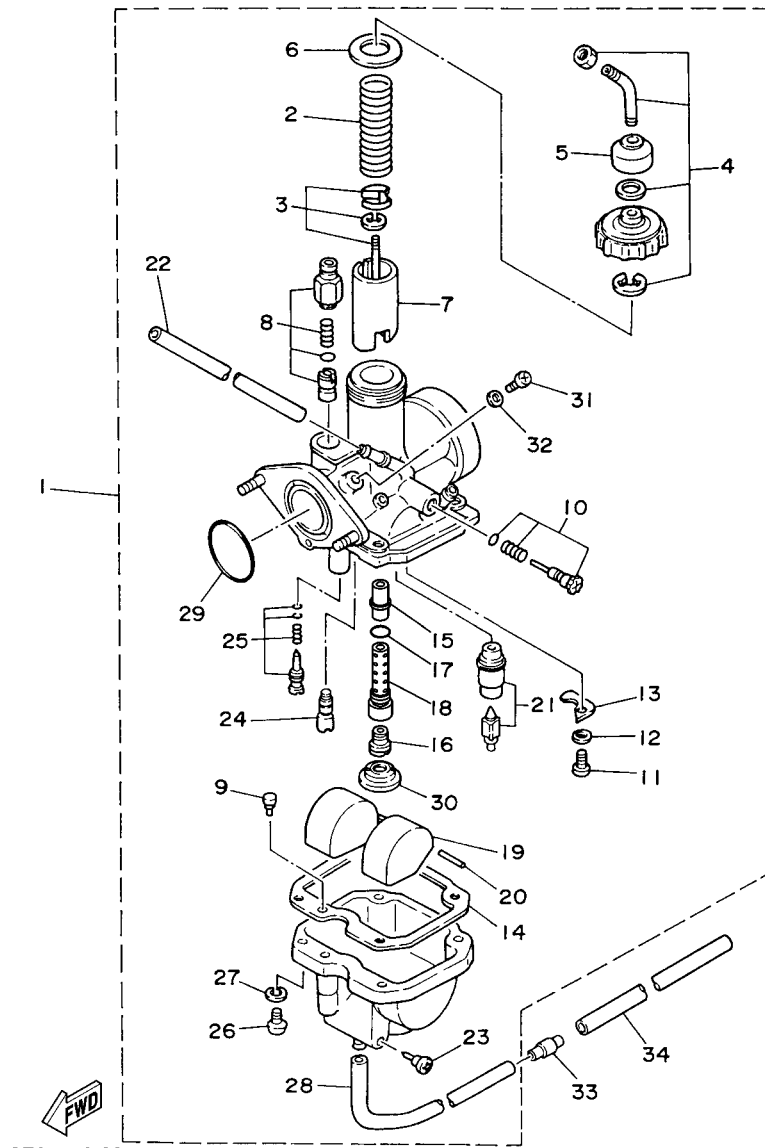

FIG. 7 CARBURETOR

REF. NO.	PART NO.	DESCRIPTION	CAN	EUR	JPN	REMARKS
1	5VJ-14101-20	CARBURETOR ASSY 1	1			
	5VJ-14101-10	CARBURETOR ASSY 1		1	1	
2	21V-14131-00	.SPRING, THROTTLE VALVE	1	1	1	
3	3FA-1490J-10	.NEEDLE SET	1	1	1	
4	10X-14106-00	.CABLE ADJUST SCREW SET	1	1	1	
5	3X3-14169-00	.CAP	1	1	1	
6	4U5-14126-00	.GASKET	1	1	1	
7	3FA-14112-25	.VALVE, THROTTLE 1	1	1	1	
8	5VJ-1410A-00	.STARTER SET	1	1	1	
9	18M-14144-09	.JET, STARTER	1	1	1	
10	18G-14103-00	.THROTTLE SCREW SET	1	1	1	
11	97802-03008	.SCREW, PAN HEAD	1	1	1	
12	92902-03100	.WASHER	1	1	1	
13	21V-14146-00	.PLATE	1	1	1	
14	24W-14184-00	.GASKET, FLOAT CHAMBER	1	1	1	
15	21V-1414M-31	.NOZZLE, MAIN	1	1	1	
16	620-1423A-66	.JET, MAIN (#77.5)	1	1	1	
17	583-14561-00	.O-RING	1	1	1	
18	3FA-14148-00	.PIPE	1	1	1	
19	21V-14185-00	.FLOAT	1	1	1	
20	127-14186-00	.PIN, FLOAT	1	1	1	
21	5HH-14190-18	.NEEDLE VALVE ASSY	1	1	1	
22	3FA-14197-00	.PIPE	1	1	1	
23	12R-14191-00	.PLUG, DRAIN	1	1	1	
24	1NT-14142-12	.JET, PILOT (# 12.5)	1	1	1	
25	3KW-14105-00	.PILOT SCREW SET	1			
	21V-14105-00	.PILOT SCREW SET		1	1	



3FA1110-9071

FIG. 7 CARBURETOR

REF. NO.	PART NO.	DESCRIPTION	CAN	EUR	JPN	REMARKS
26	98502-04014	.SCREW, PAN HEAD	4	4	4	
27	92902-04100	.WASHER, SPRING	4	4	4	
28	29U-14197-00	.PIPE	1	1	1	
29	24W-14147-00	.O-RING	1	1	1	
30	5V7-14153-00	.PLATE,BAFFLE	1	1	1	
31	92502-06008	.SCREW, PAN HEAD	1	1	1	
32	59V-14962-00	.WASHER	1	1	1	
33	24W-14193-00	PIPE	1	1	1	
34	91A20-07010	TUBE, FLEXIBLE VINYL	1	1	1	

FIG. 8 EXHAUST

REF. NO.	PART NO.	DESCRIPTION	CAN	EUR	JPN	REMARKS
1	3FA-14628-00	PROTECTOR, EXHAUST PIPE	1	1	1	
2	3FA-14711-00	MUFFLER 1	1	1	1	
3	55X-14752-00	PIPE, OUTLET	1	1	1	
4	98502-06010	SCREW, PAN HEAD	2	2	2	
5	92902-06600	WASHER, PLATE	2	2	2	
6	98902-06010	SCREW, BIND	2	2	2	
7	4BD-14766-00	WASHER, PROTECTOR	4	4	4	
8	90206-06090	WASHER, WAVE	2	2	2	
9	3DM-14613-00	GASKET, EXHAUST PIPE	1	1	1	
10	95702-06500	NUT, FLANGE	2	2	2	
11	95812-08016	BOLT, FLANGE	2	2	2	
12	90201-08048	WASHER, PLATE	2	2	2	

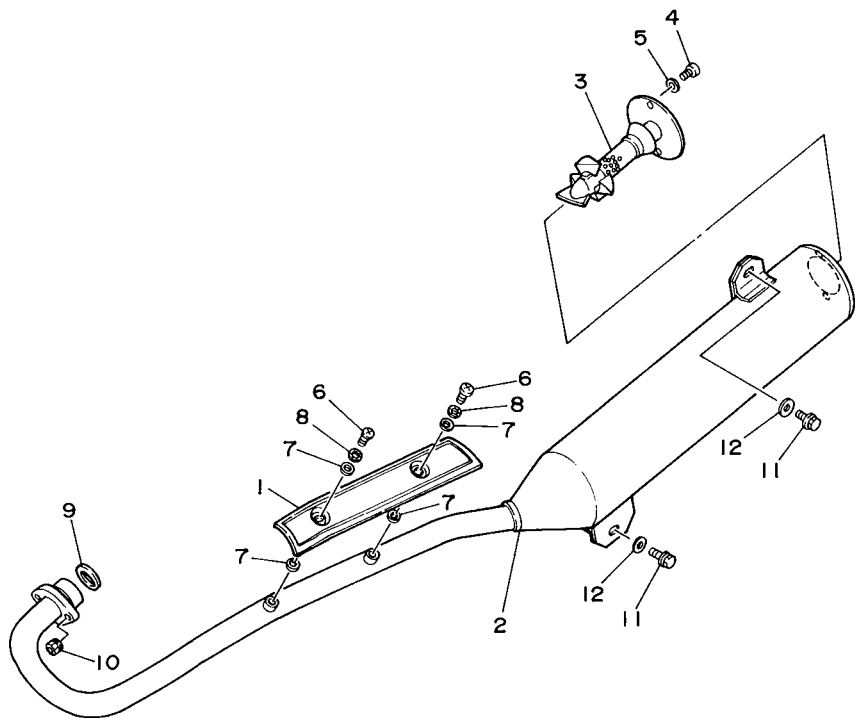

3FA1110-9080

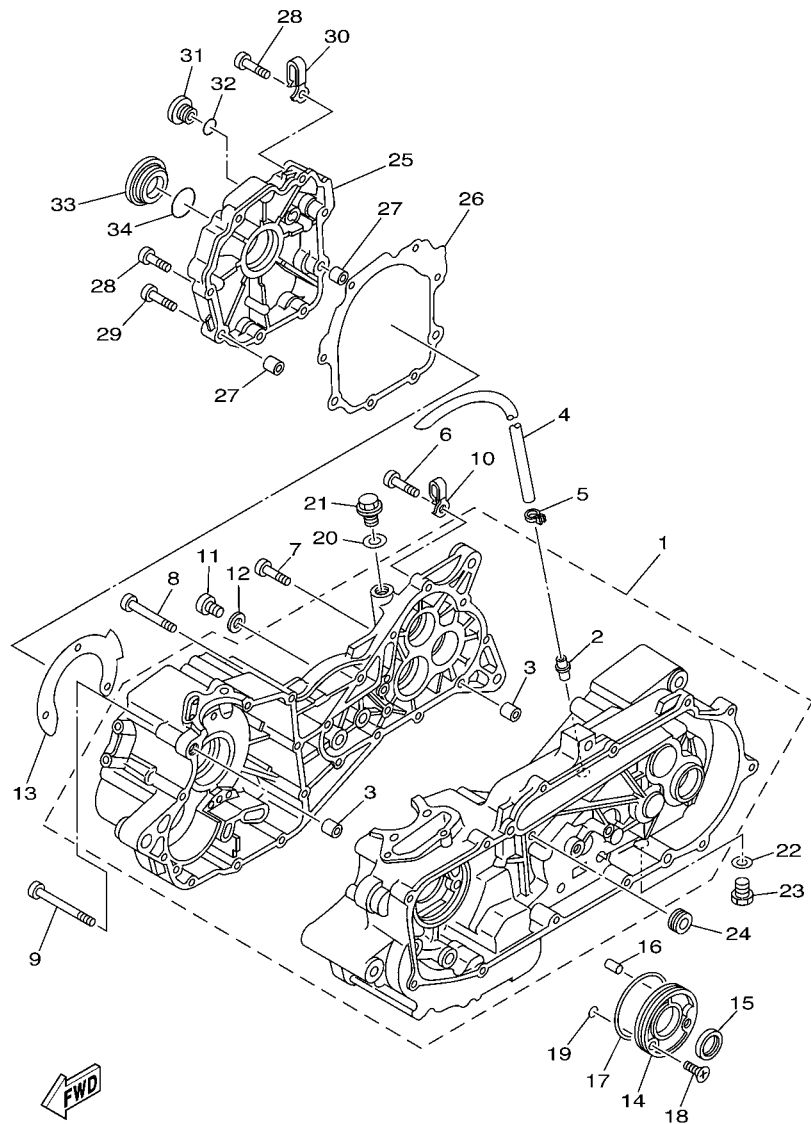

5VJ1100-3090

FIG. 9 CRANKCASE

REF. NO.	PART NO.	DESCRIPTION	CAN	EUR	JPN	REMARKS
1	3FA-15100-00	CRANKCASE ASSY	1	1	1	
2	59V-11167-00	.PIPE, BREATHER 2	1	1	1	
3	99530-12016	.PIN, DOWEL	2	2	2	
4	90445-121F6	HOSE (L700)	1	1	1	
5	90467-13064	CLIP	1	1	1	
6	98502-06030	SCREW, PAN HEAD	9	9	9	
7	98502-06040	SCREW, PAN HEAD	1	1	1	
8	98502-06060	SCREW, PAN HEAD	9	9	9	
9	98502-06070	SCREW, PAN HEAD	1	1	1	
10	90465-08127	CLAMP	1	1	1	
11	98502-08012	SCREW, PAN HEAD	1	1	1	
12	90201-08087	WASHER, PLATE	1	1	1	
13	3FA-15462-10	GASKET, CRANKCASE COVER 3	1	1	1	
14	50M-15418-00	COVER, CHAIN CASE	1	1	1	
15	93102-22294	OIL SEAL	1	1	1	
16	93605-18078	PIN, DOWEL	1	1	1	
17	93210-704A7	O-RING	1	1	1	
18	98702-06016	SCREW, FLAT HEAD	2	2	2	
19	93210-06564	O-RING	2	2	2	
20	214-11198-01	GASKET	1	1	1	
21	90340-14132	PLUG, STRAIGHT SCREW	1	1	1	
22	90430-14043	GASKET	1	1	1	
23	90340-14036	PLUG, STRAIGHT SCREW	1	1	1	
24	90480-13018	GROMMET	1	1	1	
25	3FA-15787-00	ADAPTOR	1	1	1	
26	3FA-15461-10	GASKET, CRANKCASE COVER 2	1	1	1	
27	99530-10114	PIN, DOWEL	2	2	2	

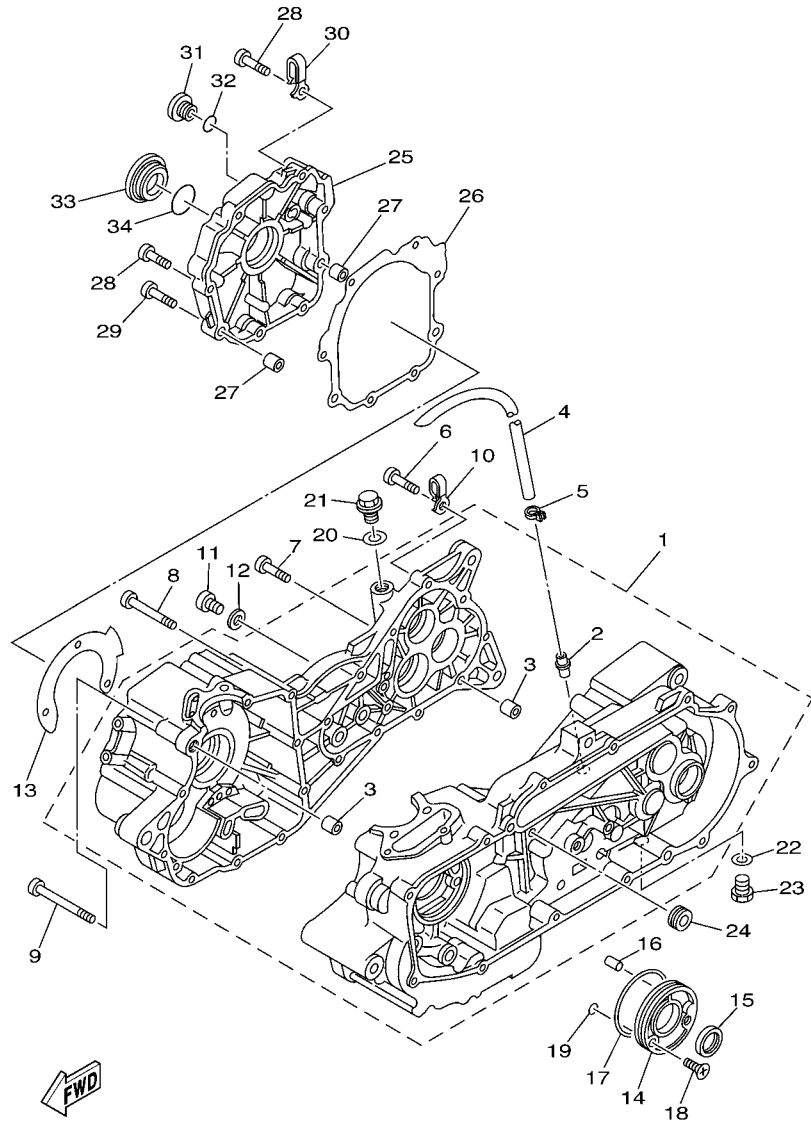



 5VJ1100-3090

FIG. 9 CRANKCASE

REF. NO.	PART NO.	DESCRIPTION	CAN	EUR	JPN	REMARKS
28	98502-06030	SCREW, PAN HEAD	6	6	6	
29	98502-06040	SCREW, PAN HEAD	2	2	2	
30	90465-08125	CLAMP	2	2	2	
31	90340-14117	PLUG, STRAIGHT SCREW	1	1	1	
32	93210-14369	O-RING	1	1	1	
33	90340-36078	PLUG, STRAIGHT SCREW	1	1	1	
34	93210-357A3	O-RING	1	1	1	

FIG. 10 CRANKCASE COVER 1

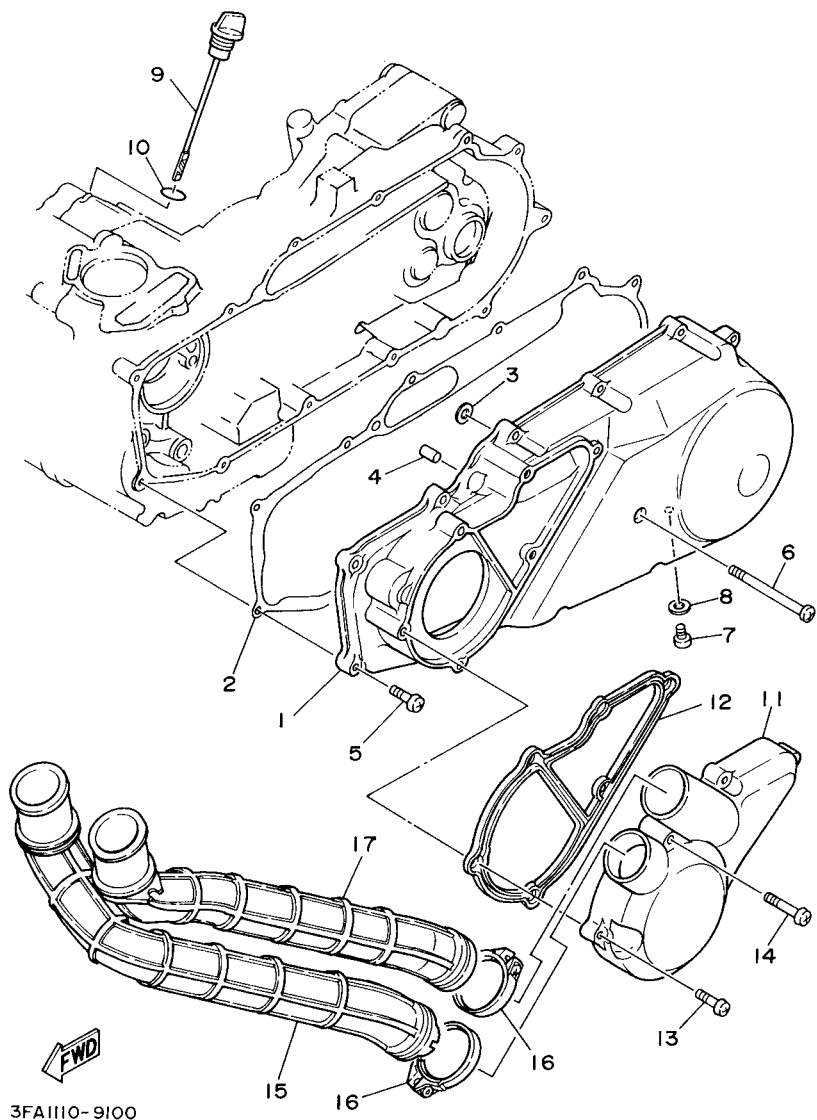
REF. NO.	PART NO.	DESCRIPTION	CAN	EUR	JPN	REMARKS
1	3FA-15411-00	COVER, CRANKCASE 1	1	1	1	
2	3FA-15451-11	GASKET, CRANKCASE COVER 1	1	1	1	
3	3FA-15467-00	GASKET	1	1	1	
4	99530-10114	PIN, DOWEL	2	2	2	
5	98502-06030	SCREW, PAN HEAD	12	12	12	
6	98502-06090	SCREW, PAN HEAD	1	1	1	
7	98502-06008	SCREW, PAN HEAD	1	1	1	
8	90201-06630	WASHER, PLATE	1	1	1	
9	3FA-15362-00	PLUG, OIL LEVEL	1	1	1	
10	93210-19123	O-RING	1	1	1	
11	3FA-15471-00	DUCT, AIR	1	1	1	
12	3FA-15472-00	SEAL, AIR DUCT	1	1	1	
13	98502-06030	SCREW, PAN HEAD	5	5	5	
14	98502-06045	SCREW, PAN HEAD	1	1	1	
15	3FA-15475-00	DUCT, AIR	1	1	1	
16	90450-54008	HOSE CLAMP ASSY	2	2	2	
17	3FA-15477-00	DUCT, AIR	1	1	1	



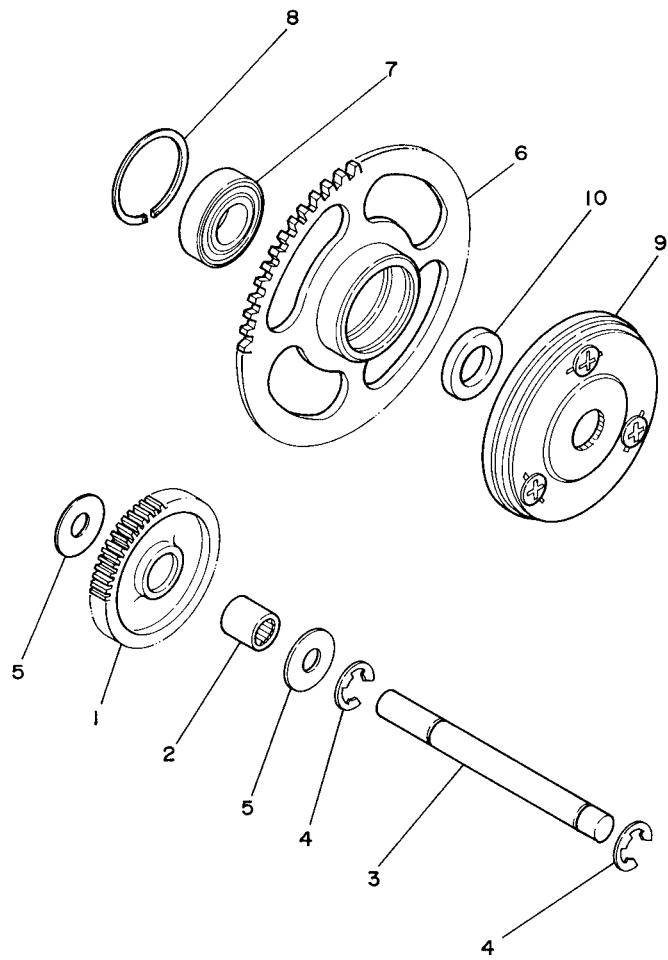

3FA1110-9110

FIG. 11 STARTER CLUTCH

REF. NO.	PART NO.	DESCRIPTION	CAN	EUR	JPN	REMARKS
1	50M-15512-00	GEAR, IDLER 1 (55T/14T)	1	1	1	
2	93315-11040	BEARING	1	1	1	
3	3FA-15521-00	SHAFT 1	1	1	1	
4	99001-09600	CIRCLIP	2	2	2	
5	90201-10061	WASHER, PLATE	2	2	2	
6	50M-15524-00	WHEEL, STARTER (55T)	1	1	1	
7	93306-00307	BEARING	1	1	1	
8	99009-35700	CIRCLIP	1	1	1	
9	50M-15570-02	STARTER CLUTCH ASSY	1	1	1	
10	90201-163F8	WASHER, PLATE	1	1	1	

FIG. 12 CLUTCH

REF. NO.	PART NO.	DESCRIPTION	CAN	EUR	JPN	REMARKS
1	3FA-16111-00	GEAR, PRIMARY DRIVE (14T)	1	1	1	
2	99009-22400	CIRCLIP	1	1	1	
3	93306-00433	BEARING	1	1	1	
4	93102-22335	OIL SEAL	1	1	1	
5	90201-06412	WASHER, PLATE	1	1	1	
6	98502-06010	SCREW, PAN HEAD	1	1	1	
7	3FA-16620-00	CLUTCH CARRIER ASSY	1	1	1	
8	14T-16626-00	.SPRING, CLUTCH WEIGHT 1	3	3	3	
9	90170-36279	NUT	1	1	1	
10	1C5-16611-01	CLUTCH HOUSING COMP.	1	1	1	
11	90179-14469	NUT	1	1	1	
12	93399-99918	BEARING	1	1	1	
13	50M-15381-00	PLATE, BEARING COVER	1	1	1	
14	98502-06010	SCREW, PAN HEAD	1	1	1	
15	3FA-17620-01	PRIMARY SLIDING SHEAVE COMP.	1	1	1	
16	93101-21170	OIL SEAL	2	2	2	
17	50M-17632-00	WEIGHT	6	6	6	
18	50W-17623-00	CAM	1	1	1	
19	4CW-17653-00	SLIDER	3	3	3	
20	93210-97690	O-RING	1	1	1	
21	50M-17630-00	PRIMARY SHEAVE CAP COMP.	1	1	1	
22	98980-04012	SCREW, BIND	3	3	3	
23	90214-04038	WASHER, CLAW	3	3	3	
24	50M-1763E-01	PLATE	1	1	1	
25	90387-161V0	COLLAR	1	1	1	
26	3FA-17641-00	V-BELT	1	1	1	
27	3FA-17611-01	SHEAVE, PRIMARY FIXED	1	1	1	

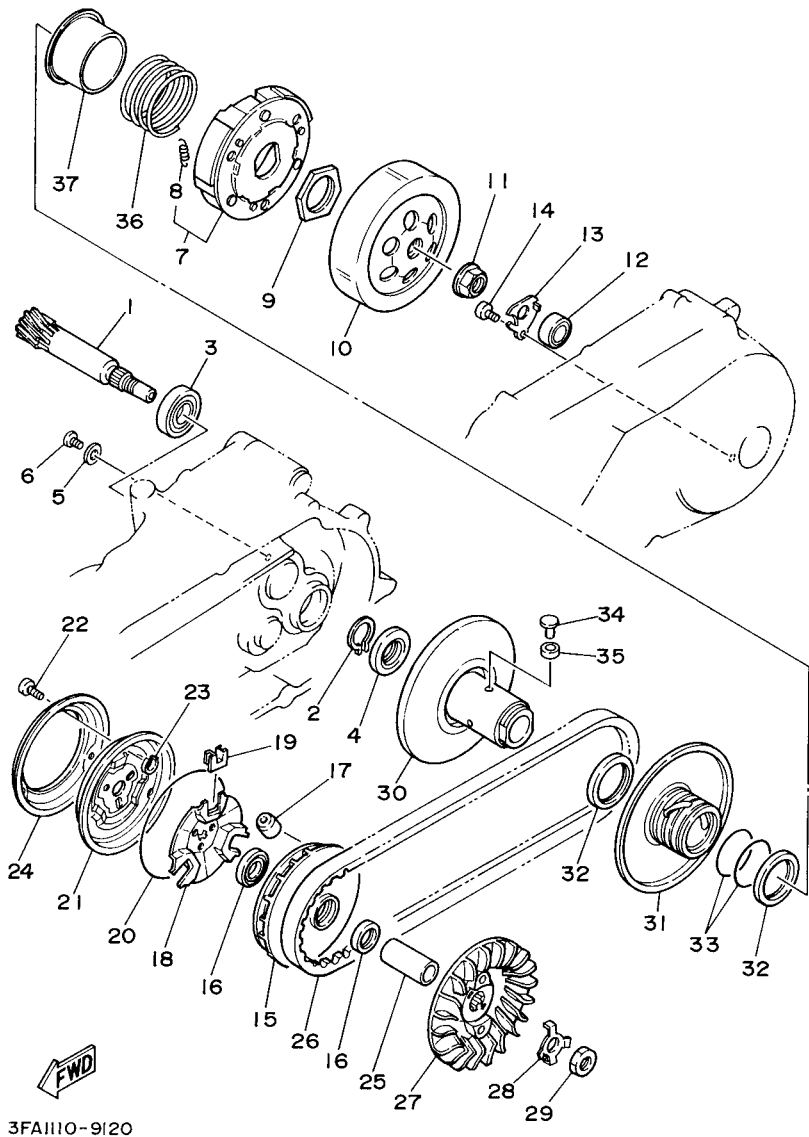

3FA1110-9120

FIG. 12 CLUTCH

REF. NO.	PART NO.	DESCRIPTION	CAN	EUR	JPN	REMARKS
28	90215-14236	WASHER, LOCK	1	1	1	
29	90170-12011	NUT	1	1	1	
30	3FA-17660-02	SECONDARY FIXED SHEAVE COMP.	1	1	1	
31	3FA-17670-00	SECONDARY SLIDING SHEAVE	1	1	1	
32	93104-41119	OIL SEAL	2	2	2	
33	93210-43713	O-RING	2	2	2	
34	50W-17664-00	PIN, GUIDE	3	3	3	
35	50W-17674-00	COLLAR, GUIDE	3	3	3	
36	90501-505F1	SPRING, COMPRESSION	1	1	1	
37	3FA-17684-00	SEAT, SECONDARY SPRING	1	1	1	
<hr/>						
<hr/>						
<hr/>						
<hr/>						
<hr/>						
<hr/>						
<hr/>						
<hr/>						
<hr/>						
<hr/>						
<hr/>						

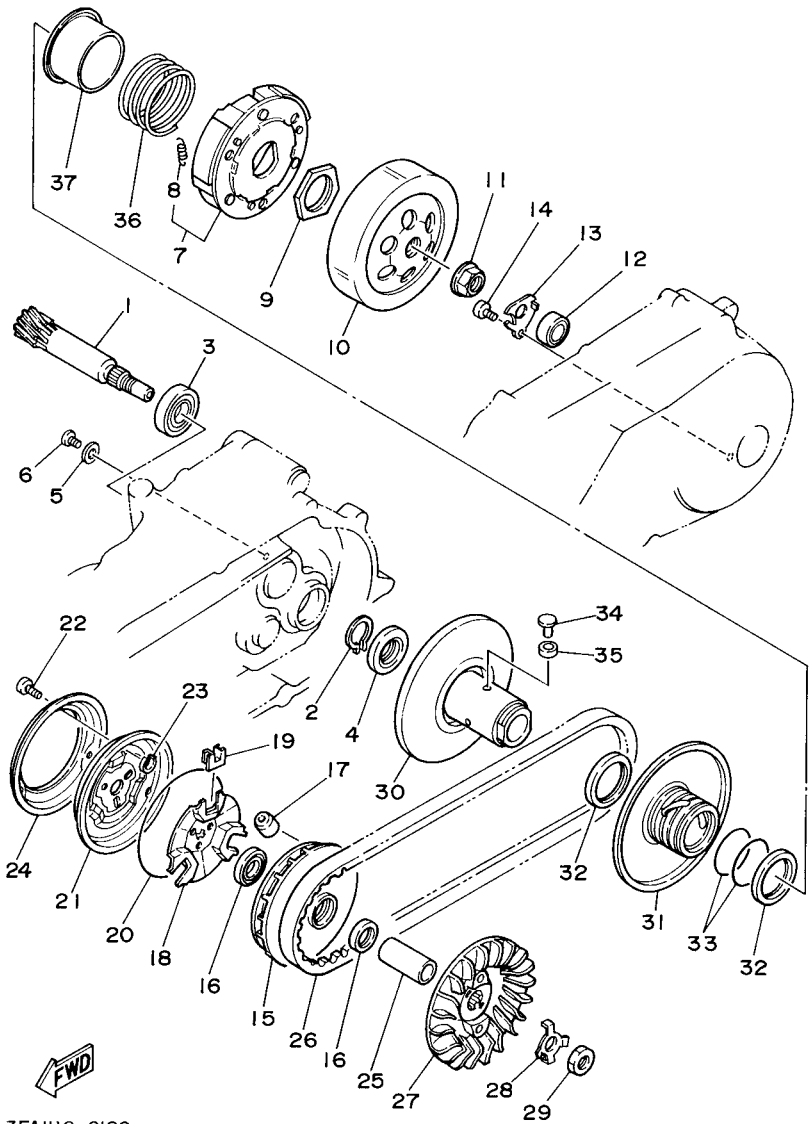

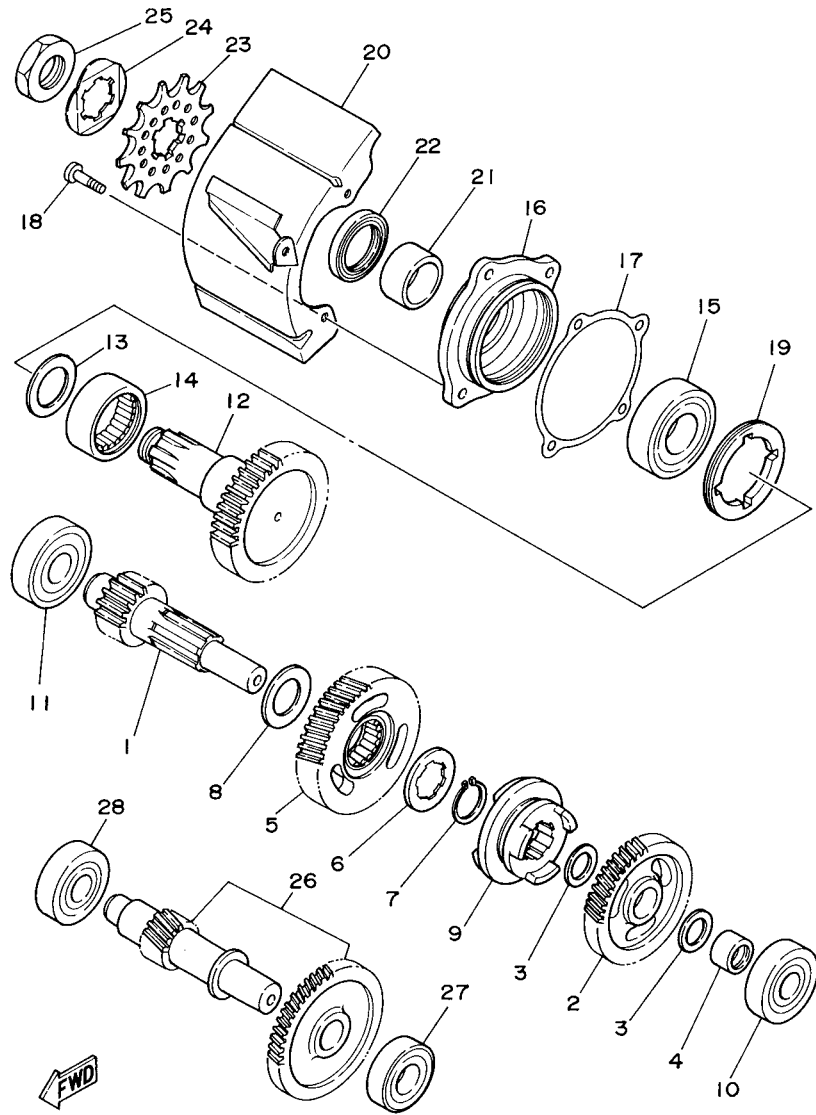

3FA1110-9130

FIG. 13 TRANSMISSION

REF. NO.	PART NO.	DESCRIPTION	CAN	EUR	JPN	REMARKS
1	3FA-17411-00	AXLE, MAIN (17T)	1	1	1	
2	3FA-16151-00	GEAR, PRIMARY DRIVEN (43T)	1	1	1	
3	90201-15700	WASHER, PLATE	2	2	2	
4	90560-15348	SPACER	1	1	1	
5	3FA-17270-00	REDUCTION GEAR ASSY (49T)	1	1	1	
6	90215-22276	WASHER, LOCK	1	1	1	
7	93410-22039	CIRCLIP	1	1	1	
8	90201-221M8	WASHER, PLATE	1	1	1	
9	3FA-17285-00	CLUTCH, DOG	1	1	1	
10	93306-20201	BEARING	1	1	1	
11	93306-20401	BEARING	1	1	1	
12	3FA-17421-00	AXLE, DRIVE (40T)	1	1	1	
13	90201-252A4	WASHER, PLATE	1	1	1	
14	93311-43048	BEARING	1	1	1	
15	93306-20532	BEARING	1	1	1	
16	3FA-17551-00	HOUSING, BEARING	1	1	1	
17	3FA-17519-10	GASKET, HOUSING CAP	1	1	1	
18	91312-06020	BOLT	4	4	4	
19	90179-55464	NUT	1	1	1	
20	3FA-17471-01	PLATE, COVER	1	1	1	
21	90387-251W4	COLLAR	1	1	1	
22	93102-30243	OIL SEAL	1	1	1	
23	93834-12016	SPROCKET,DRIVE 12T(38V1746120)	1	1	1	
24	90215-21239	WASHER, LOCK	1	1	1	
25	90179-20255	NUT	1	1	1	
26	3FA-17430-00	COUNTER AXLE ASSY (15T)	1	1	1	
27	93306-20301	BEARING	1	1	1	

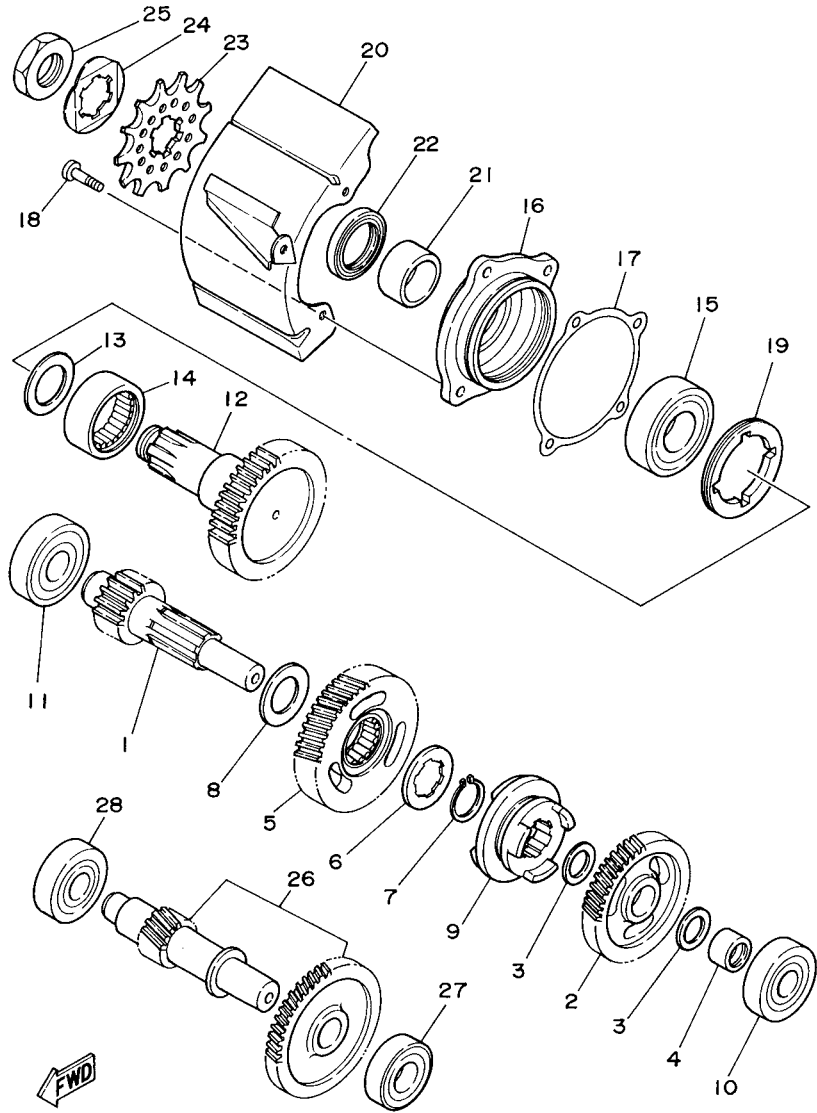

3FA1110-9130

FIG. 13 TRANSMISSION

REF. NO.	PART NO.	DESCRIPTION	CAN	EUR	JPN	REMARKS
28	93306-30201	BEARING	1	1	1	

FIG. 14 SHIFT CAM & FORK

REF. NO.	PART NO.	DESCRIPTION	CAN	EUR	JPN	REMARKS
1	3FA-18540-00	SHIFT CAM ASSY	1	1	1	
2	93503-08007	BALL	1	1	1	
3	90501-10353	SPRING, COMPRESSION	1	1	1	
4	90105-14003	BOLT, FLANGE	1	1	1	
5	90430-14194	GASKET	1	1	1	
6	4GB-18512-00	FORK, SHIFT 2	1	1	1	
7	1HX-18535-00	BAR, SHIFT FORK GUIDE 2	1	1	1	
8	3FA-18101-01	SHIFT SHAFT ASSY	1	1	1	
9	99001-12600	CIRCLIP	2	2	2	
10	93102-14209	OIL SEAL	1	1	1	
11	3FA-18152-00	LEVER, SHIFT 4	1	1	1	
12	3FA-18164-00	BOSS, SHIFT	1	1	1	
13	90508-29760	SPRING, TORSION	1	1	1	
14	91701-08058	PIN	1	1	1	
15	92902-08600	WASHER, PLATE	2	2	2	
16	91401-25015	PIN, COTTER	1	1	1	
17	3FA-18174-00	KNOB, SHIFT LEVER	1	1	1	
18	90269-05055	RIVET	1	1	1	
19	95822-06025	BOLT, FLANGE	1	1	1	
20	91312-06016	BOLT	2	2	2	
21	3FA-18128-00	BRACKET	1	1	1	
22	92902-06600	WASHER, PLATE	2	2	2	
23	3FA-18191-00	LEVER	1	1	1	
24	90508-12761	SPRING, TORSION	1	1	1	
25	90109-06189	BOLT	1	1	1	

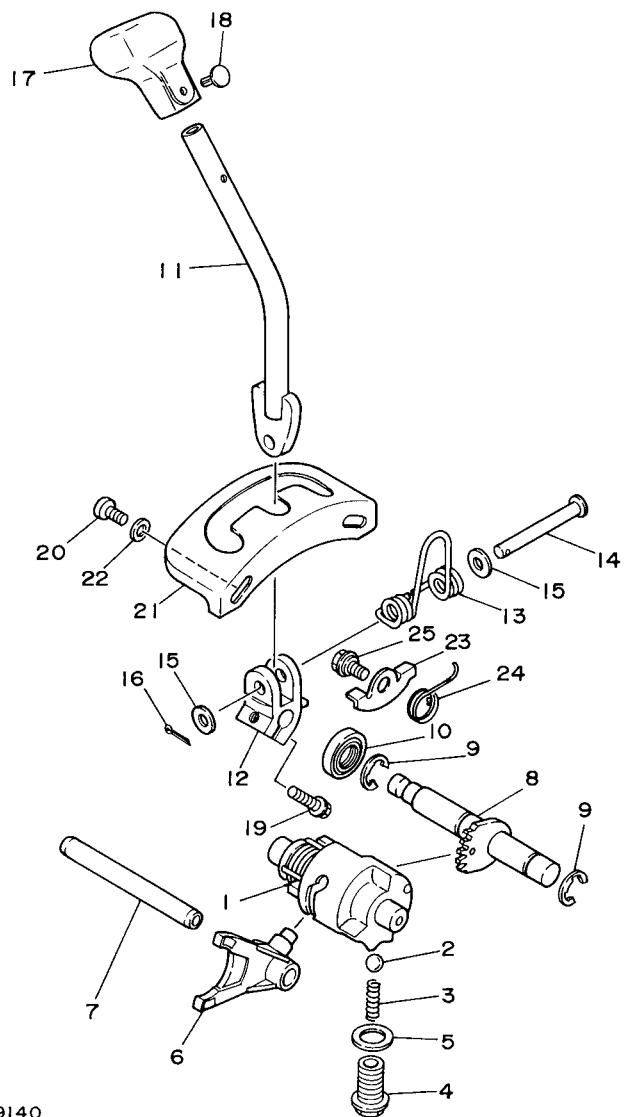

3FA1110-9140

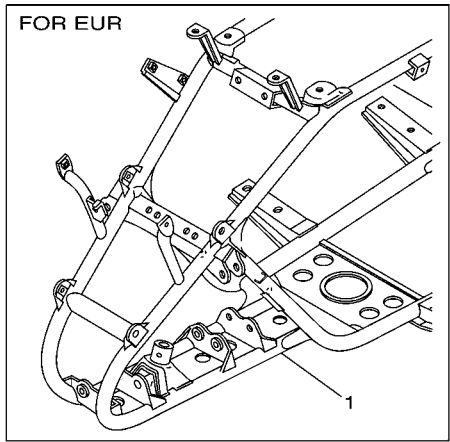
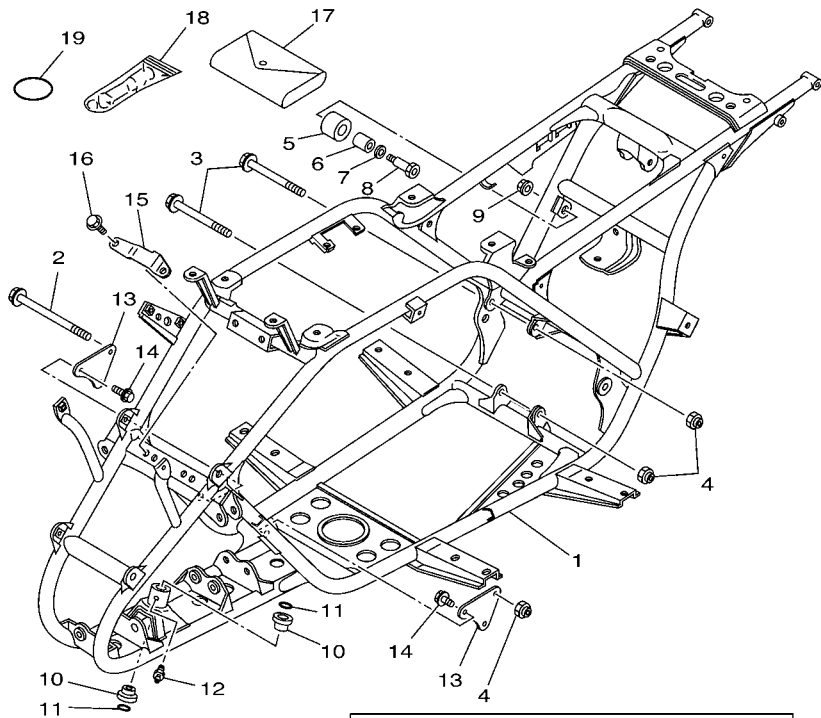

 1C51100-C150

FIG. 15 FRAME

REF. NO.	PART NO.	DESCRIPTION	CAN	EUR	JPN	REMARKS
1	1C5-21110-20	FRAME COMP.	1		1	
	1C5-21110-30	FRAME COMP.		1		
2	90105-10183	BOLT, FLANGE	1	1	1	
3	90105-10277	BOLT, FLANGE	2	2	2	
4	90185-10022	NUT, SELF-LOCKING	3	3	3	
5	10V-22178-00	TENSIONER	1	1	1	
6	4V4-22184-00	BUSH	1	1	1	
7	90201-13409	WASHER, PLATE	1	1	1	
8	90109-08705	BOLT	1	1	1	
9	90185-08016	NUT, SELF-LOCKING	1	1	1	
10	90381-15040	BUSH, SOLID	2	2	2	
11	93210-15414	O-RING	2	2	2	
12	93700-06004	NIPPLE, GREASE	1	1	1	
13	3FA-21315-00	STAY, ENGINE 2	2	2	2	
14	95812-08016	BOLT, FLANGE	4	4	4	
15	3FA-2115K-10	BRACKET, 1	1	1	1	
16	95802-06012	BOLT, FLANGE	2	2	2	
17	3GB-28100-00	TOOL KIT	1	1	1	
18	1NV-2811A-01	GAUGE, AIR	1	1	1	
19	93210-41041	O-RING	1	1	1	

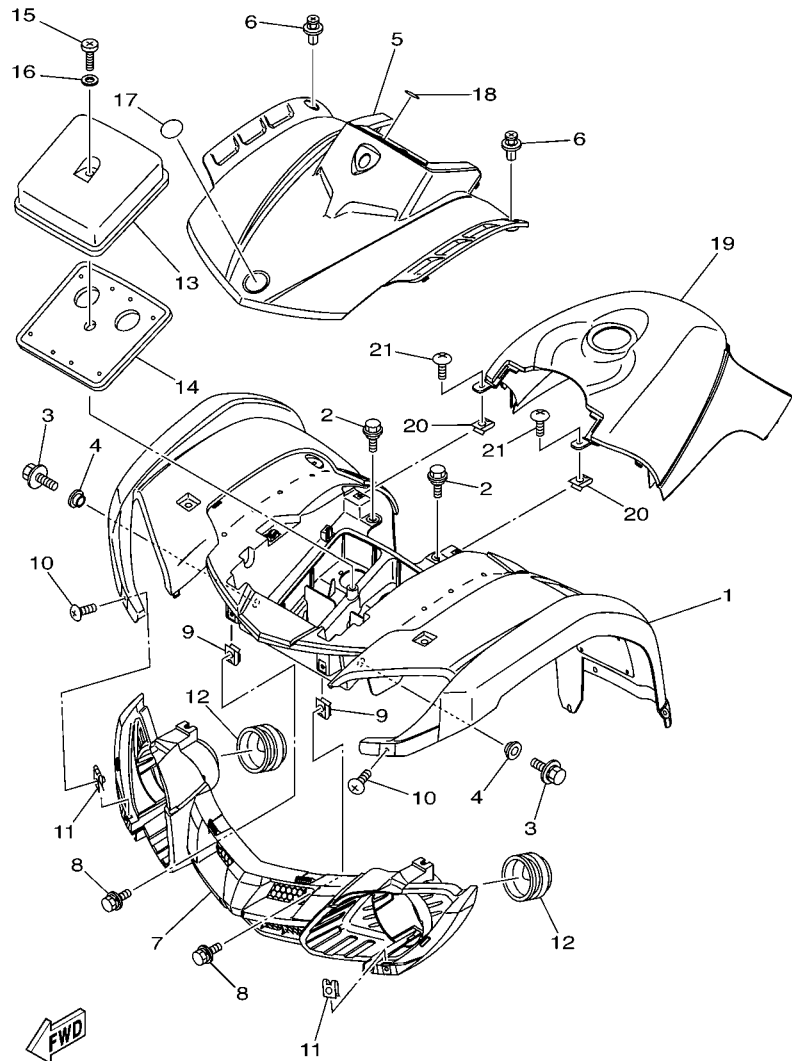

1C51100-C160

FIG. 16 FRONT FENDER

REF. NO.	PART NO.	DESCRIPTION	CAN	EUR	JPN	REMARKS
1	1C5-W215C-12	FRONT FENDER COMP.2	1			
	1C5-W215B-12	FRONT FENDER COMP. 2		1		
	1C5-W215D-10	FRONT FENDER COMP. 2			1	
2	90109-06172	BOLT	2	2	2	
3	90119-06147	BOLT, WITH WASHER	2	2	2	
4	90387-06153	COLLAR	2	2	2	
5	1C5-23391-00	PANEL, FRONT	1	1	1	
6	90269-07076	RIVET	2	2	2	
7	1C5-28309-00	GRILLE, FRONT	1	1	1	
8	90119-06201	BOLT, WITH WASHER	2	2	2	
9	90183-060A7	NUT, SPRING	2	2	2	
10	90150-06016	SCREW, ROUND HEAD	2	2	2	
11	90183-06053	NUT, SPRING	2	2	2	
12	5GH-28349-00	CAP	2	2	2	
13	3FA-14422-10	CAP, CLEANER CASE 2	1	1	1	
14	3FA-14461-00	ELEMENT, AIR CLEANER 2	1	1	1	
15	98502-05020	SCREW, PAN HEAD	1	1	1	
16	92902-05600	WASHER, PLATE	1	1	1	
17	5KM-2175B-00	TUNING FORK MARK	1	1	1	
18	5GT-2836B-10	TUNING FORK MARK	1	1	1	
19	1C5-2171A-10	COVER, TOP	1	1	1	
20	90183-06053	NUT, SPRING	2	2	2	
21	90150-06016	SCREW, ROUND HEAD	2	2	2	

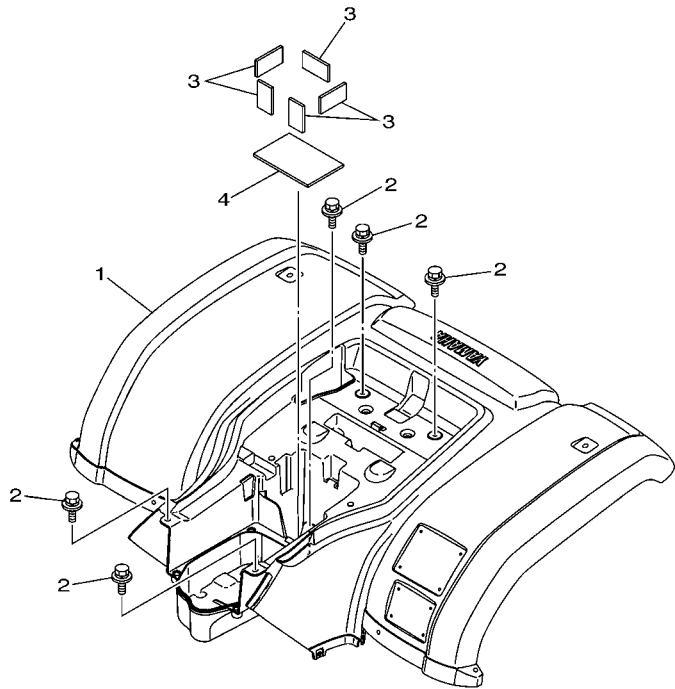

1C51100-C170

FIG. 17 REAR FENDER

REF. NO.	PART NO.	DESCRIPTION	CAN	EUR	JPN			REMARKS
1	1C5-W216C-11	REAR FENDER COMP.2	1					
	1C5-W216B-11	REAR FENDER COMP.2		1				
	1C5-W216D-10	REAR FENDER COMP			1			
2	90119-06152	BOLT, WITH WASHER	5	5	5			
3	29W-82123-00	SEAT, BATTERY	5	5	5			
4	1UY-21639-00	DAMPER 2	1	1	1			

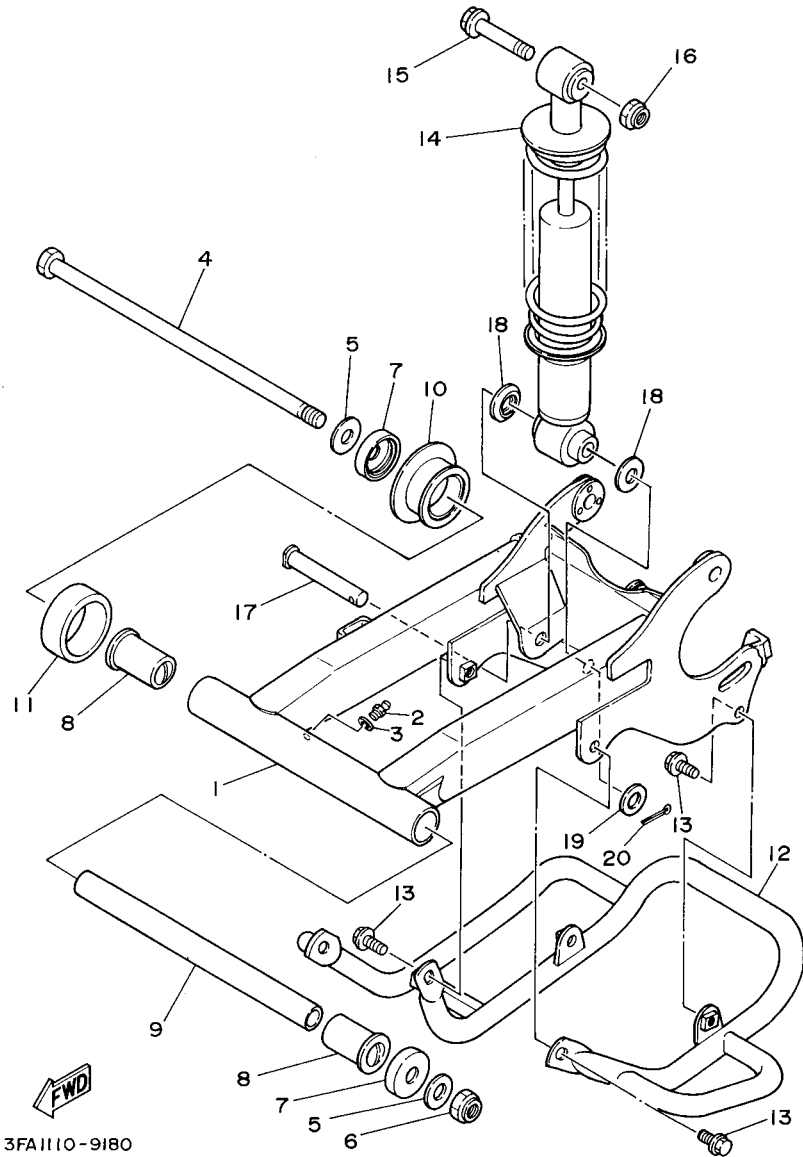

3FA1110-9180

FIG. 18 REAR ARM & SUSPENSION

REF. NO.	PART NO.	DESCRIPTION	CAN	EUR	JPN	REMARKS
1	3FA-22110-00-33	REAR ARM COMP.	1	1	1	YB
2	93700-06004	NIPPLE, GREASE	1	1	1	
3	92902-06200	WASHER	1	1	1	
4	2JX-22141-00	SHAFT, PIVOT	1	1	1	
5	90201-12045	WASHER, PLATE	2	2	2	
6	90185-12007	NUT, SELF-LOCKING	1	1	1	
7	401-22128-01	COVER, THRUST 1	2	2	2	
8	90386-18028	BUSH	2	2	2	
9	3FA-22126-00	COLLAR, DISTANCE	1	1	1	
10	2A6-22151-00	SEAL, GUARD	1	1	1	
11	2A6-22152-00	SEAL, GUARD	1	1	1	
12	3FA-2219X-00	COVER	1	1	1	
13	95822-08016	BOLT, FLANGE	5	5	5	
14	3FA-22210-00-33	SHOCK ABSORBER ASSY, REAR	1	1	1	YB
15	90105-10131	BOLT, FLANGE	1	1	1	
16	90185-10022	NUT, SELF-LOCKING	1	1	1	
17	90240-12092	PIN, CLEVIS	1	1	1	
18	1W1-22128-00	COVER, THRUST 1	2	2	2	
19	90201-12047	WASHER, PLATE	1	1	1	
20	91401-30025	PIN, COTTER	1	1	1	

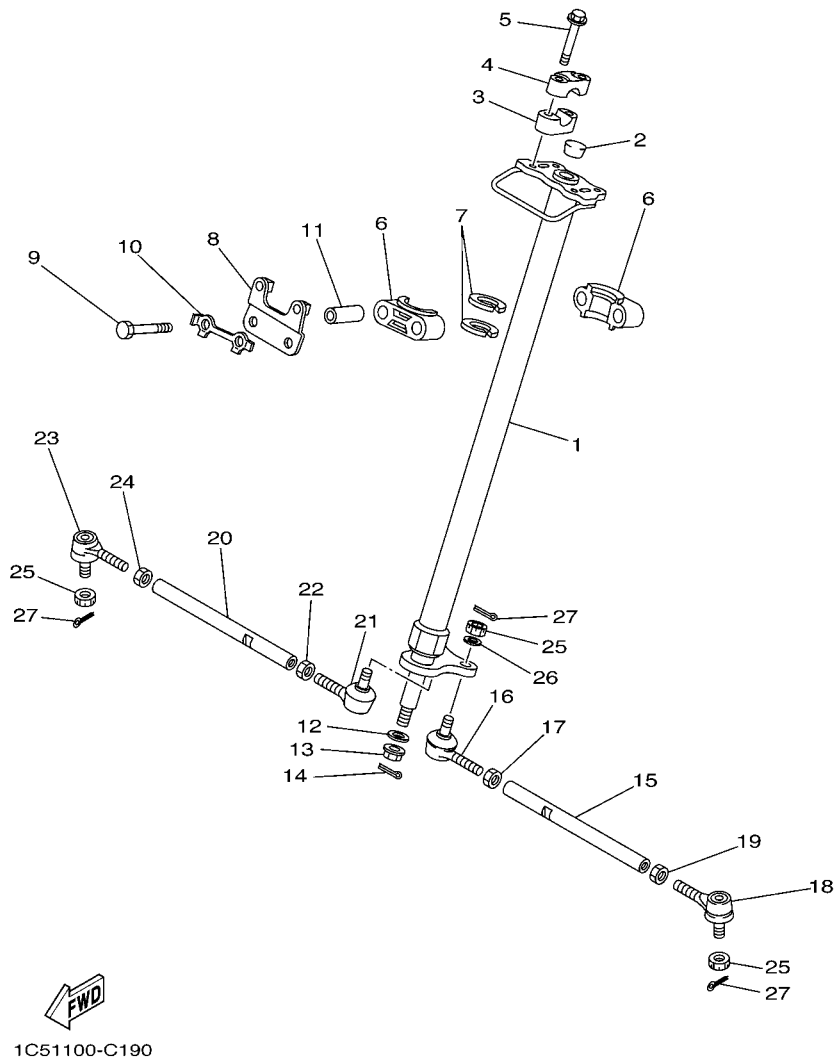
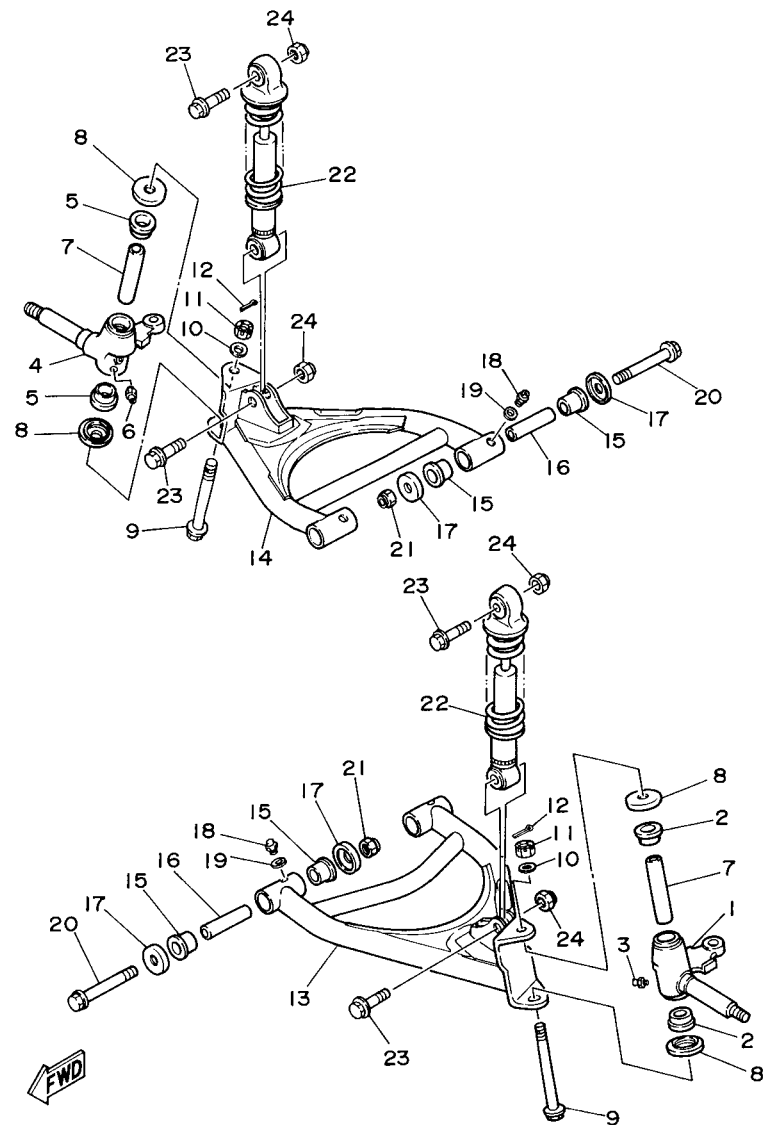

FIG. 19 STEERING

REF. NO.	PART NO.	DESCRIPTION	CAN	EUR	JPN	REMARKS
1	1C5-23813-20	COLUMN, STEERING 2	1	1	1	
2	90336-22056	PLUG, TAPER	1	1	1	
3	2HR-23442-00	HOLDER, HANDLE LOWER	2	2	2	
4	8K1-23814-00	HOLDER, HANDLE	2	2	2	
5	95822-08050	BOLT, FLANGE	4	4	4	
6	1UY-23812-00	BEARING, STEERING	2	2	2	
7	93112-31011	OIL SEAL	2	2	2	
8	3FA-23868-30	BRACKET, STEERING LOWER	1	1	1	
9	97022-08060	BOLT	2	2	2	
10	1UY-23894-01	WASHER, LOCK 1	1	1	1	
11	90387-090R0	COLLAR	2	2	2	
12	90201-10036	WASHER, PLATE	1	1	1	
13	90185-10019	NUT, SELF-LOCKING	1	1	1	
14	91401-20020	PIN, COTTER	1	1	1	
15	3FA-23831-10	ROD, TIE	1	1	1	
16	1UY-23841-01	JOINT, UNIVERSAL 1	1	1	1	
17	95302-10700	NUT	1	1	1	
18	1UY-23845-01	JOINT, UNIVERSAL 2	1	1	1	
19	90170-10010	NUT	1	1	1	(L.H. THREAD)
20	3FA-23831-10	ROD, TIE	1	1	1	
21	1UY-23841-01	JOINT, UNIVERSAL 1	1	1	1	
22	95302-10700	NUT	1	1	1	
23	1UY-23845-01	JOINT, UNIVERSAL 2	1	1	1	
24	90170-10010	NUT	1	1	1	(L.H. THREAD)
25	90171-10001	NUT, CASTLE	4	4	4	
26	92990-10600	WASHER, PLATE	2	2	2	
27	91401-20020	PIN, COTTER	4	4	4	

FIG. 20 FRONT SUSPENSION & WHEEL



3FA1110-9190

REF. NO.	PART NO.	DESCRIPTION	CAN	EUR	JPN	REMARKS
1	3FA-23511-01	KNUCKLE, STEERING 1	1	1	1	
2	90381-17067	BUSH, SOLID	2	2	2	
3	93700-06004	NIPPLE, GREASE	1	1	1	
4	3FA-23521-01	KNUCKLE, STEERING 2	1	1	1	
5	90381-17067	BUSH, SOLID	2	2	2	
6	93700-06004	NIPPLE, GREASE	1	1	1	
7	3GB-23448-00	SPACER	2	2	2	
8	2NL-23517-00	COVER, THRUST 1	4	4	4	
9	90105-10274	BOLT, FLANGE	2	2	2	
10	90201-10057	WASHER, PLATE	2	2	2	
11	90171-10003	NUT, CASTLE	2	2	2	
12	91401-20020	PIN, COTTER	2	2	2	
13	3FA-23570-00-33	FRONT LOWER ARM COMP. (LEFT)	1	1	1	YB
14	3FA-23580-00-33	FRONT LOWER ARM COMP. (RIGHT)	1	1	1	YB
15	90381-15088	BUSH, SOLID	8	8	8	
16	90387-101R3	COLLAR	4	4	4	
17	5YT-23517-00	COVER, THRUST 1	8	8	8	
18	93700-06004	NIPPLE, GREASE	4	4	4	
19	92902-06200	WASHER	4	4	4	
20	90105-10233	BOLT, FLANGE	4	4	4	
21	90185-10022	NUT, SELF-LOCKING	4	4	4	
22	3FA-23350-00-33	SHOCK ABSORBER ASSY	2	2	2	YB
23	90105-10262	BOLT, FLANGE	4	4	4	
24	90185-10022	NUT, SELF-LOCKING	4	4	4	

FIG. 21 FUEL TANK

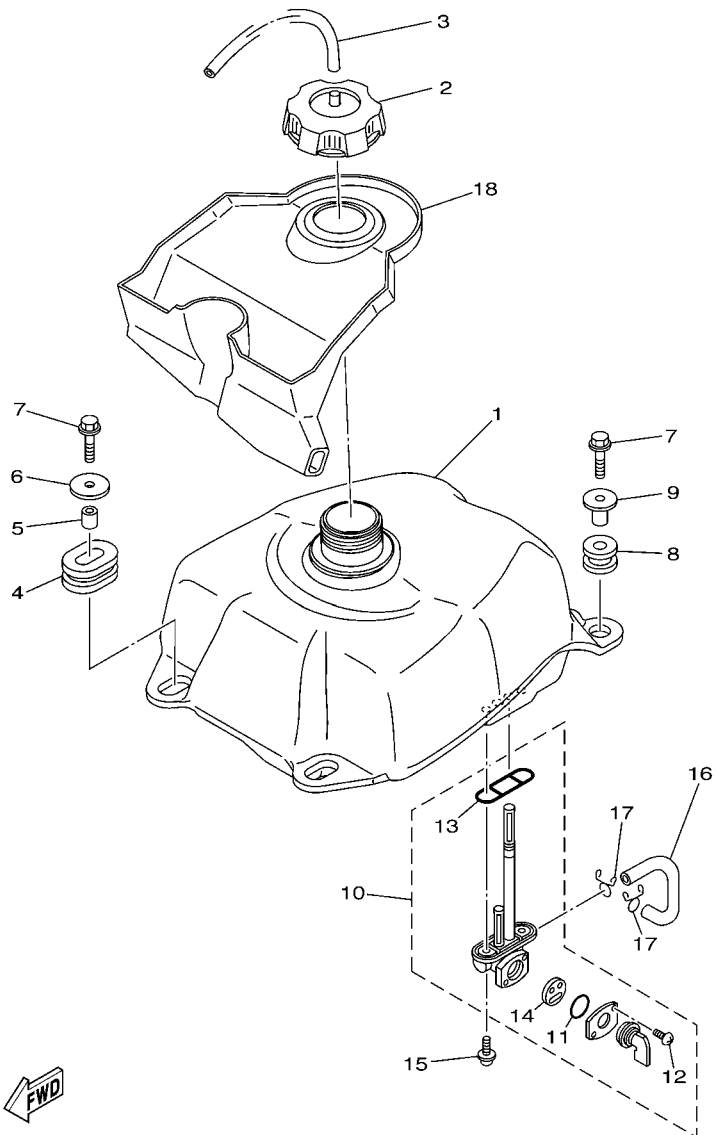

1C51100-C210

REF. NO.	PART NO.	DESCRIPTION	CAN	EUR	JPN	REMARKS
1	1C5-24110-10	FUEL TANK COMP.	1			
	1C5-24110-00	FUEL TANK COMP.		1	1	
2	2FJ-24610-10	CAP ASSY	1	1	1	
3	90445-09304	HOSE (L310)	1	1	1	
4	90480-01400	GROMMET	2	2	2	
5	90387-07598	COLLAR	2	2	2	
6	90201-06090	WASHER, PLATE	2	2	2	
7	95822-06035	BOLT, FLANGE	4	4	4	
8	90480-18290	GROMMET	2	2	2	
9	90387-066H4	COLLAR	2	2	2	
10	55W-24500-10	FUEL COCK ASSY 1	1	1	1	
11	3AJ-24534-10	.SEAL, COCK	1	1	1	
12	98507-03008	.SCREW, PAN HEAD	2	2	2	
13	4X8-24512-10	.GASKET	1	1	1	
14	3AC-24523-00	.VALVE PACKING	1	1	1	
15	90149-06108	SCREW	2	2	2	
16	90445-10043	HOSE (L95)	1			
	90445-10456	HOSE (L95)		1	1	
17	90467-09006	CLIP	2	2	2	
18	1C5-2414H-00	DAMPER, PLATE 1	1	1	1	

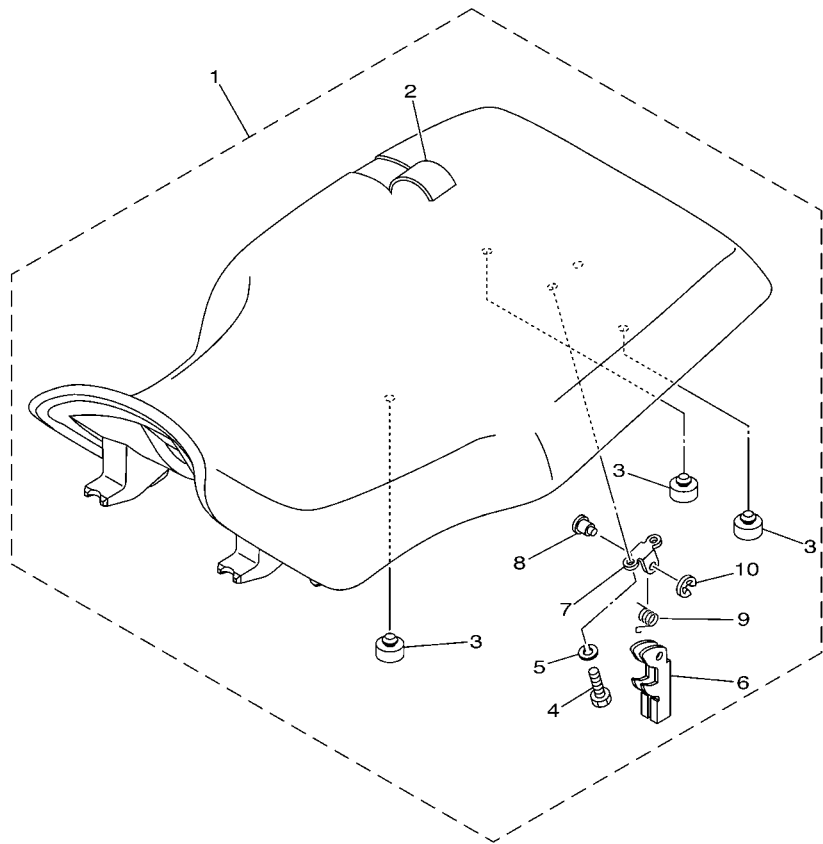

 1C51100-C220

FIG. 22 SEAT

REF. NO.	PART NO.	DESCRIPTION	CAN	EUR	JPN	REMARKS
1	1C5-24710-10	SINGLE SEAT ASSY	1	1	1	
2	1C5-24731-00	.COVER, SEAT	1	1	1	
3	371-27114-00	.STOPPER, MAIN STAND	3	3	3	
4	97002-06012	.BOLT	2	2	2	
5	92902-06100	.WASHER, SPRING	2	2	2	
6	29U-24776-00	.LEVER, SEAT	1	1	1	
7	4K0-24775-00	.BRACKET, SEAT LEVER	1	1	1	
8	4K0-24774-01	.PIN	1	1	1	
9	90508-20779	.SPRING, TORSION	1	1	1	
10	99001-04600	.CIRCLIP	1	1	1	

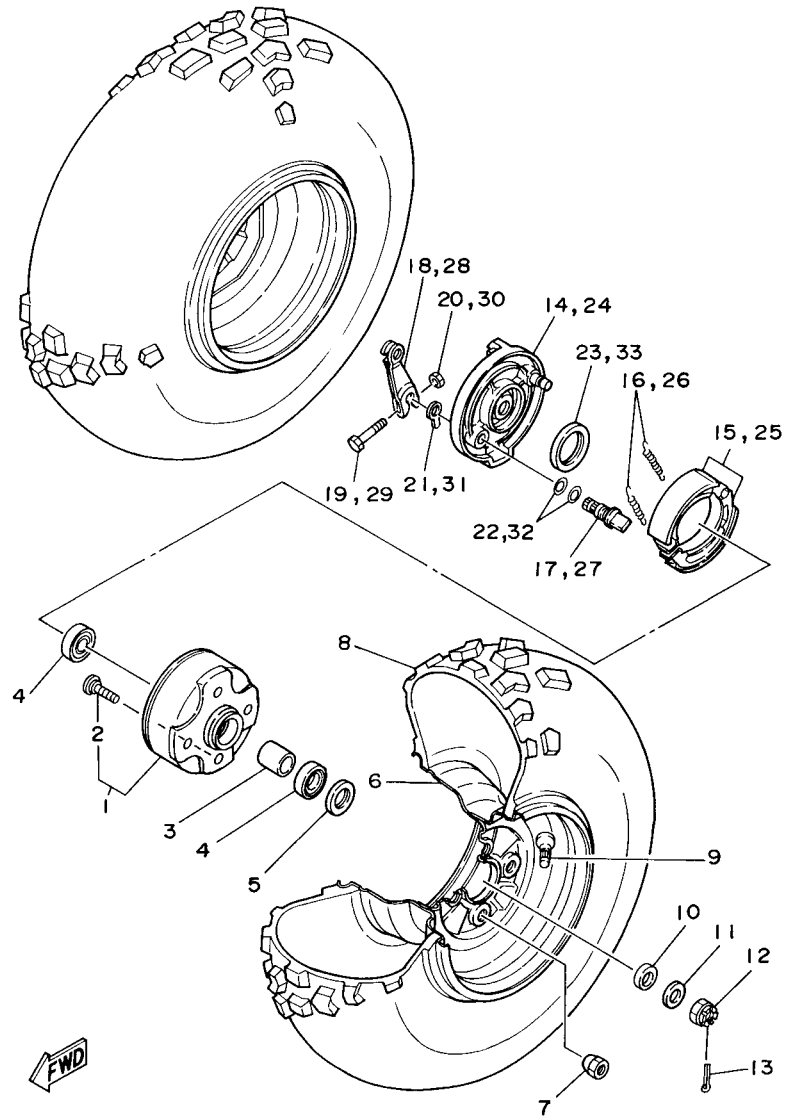

3FAK100-8230

FIG. 23 FRONT WHEEL

REF. NO.	PART NO.	DESCRIPTION	CAN	EUR	JPN	REMARKS
1	1C5-25111-00	HUB, FRONT	2	2	2	
2	90114-10014	.BOLT, SERRATION	4	4	4	
3	3FA-25117-00	SPACER, BEARING	2	2	2	
4	93306-00308	BEARING	4	4	4	
5	93102-23275	OIL SEAL	2	2	2	
6	3FA-25180-00-98	WHEEL COMP.	2	2	2	LGB
7	90179-10022	NUT	8	8	8	
8	94107-08008	TIRE (AT20X7-8*KT536A T/L N)	2	2	2	DUNLOP
9	93900-00022	VALVE, RIM (TR413)	2	2	2	TAIHEIYO
10	90387-175R2	COLLAR	2	2	2	
11	90201-14586	WASHER, PLATE	2	2	2	
12	90171-14002	NUT, CASTLE	2	2	2	
13	91401-30025	PIN, COTTER	2	2	2	
14	3FA-25121-00	PLATE, BRAKE SHOE	1	1	1	FOR LH
15	4BE-W2536-00	BRAKE SHOE SET	1	1	1	
16	90506-15260	SPRING, TENSION	2	2	2	
17	5G3-25351-02	CAMSHAFT	1	1	1	
18	3FA-25155-00	LEVER, CAMSHAFT 1	1	1	1	FOR LH
19	90101-06046	BOLT	1	1	1	
20	95302-06600	NUT	1	1	1	
21	52H-2513A-00	PLATE, INDICATOR	1	1	1	
22	93210-12327	O-RING	2	2	2	
23	93102-40367	OIL SEAL	1	1	1	
24	3FA-25169-00	PLATE, BRAKE SHOE 2	1	1	1	FOR RH
25	4BE-W2536-00	BRAKE SHOE SET	1	1	1	
26	90506-15260	SPRING, TENSION	2	2	2	
27	5G3-25351-02	CAMSHAFT	1	1	1	

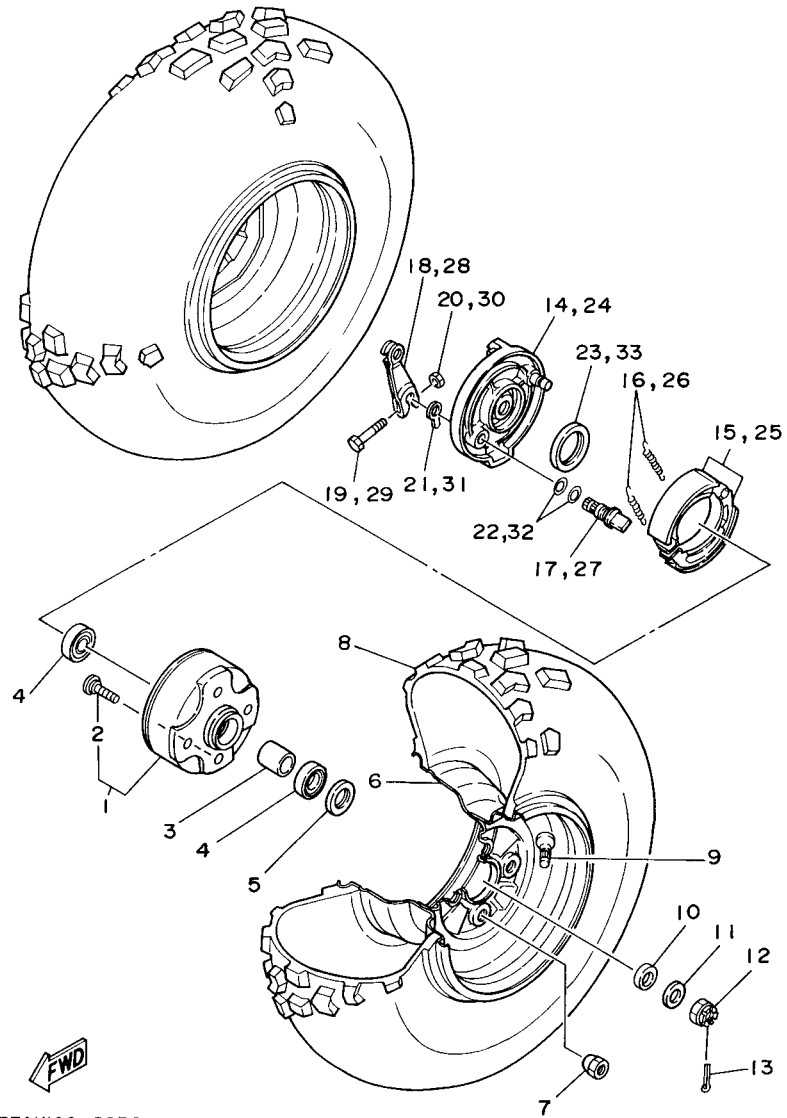

3FAK100-8230

FIG. 23 FRONT WHEEL

REF. NO.	PART NO.	DESCRIPTION	CAN	EUR	JPN	REMARKS
28	3FA-25156-00	LEVER, CAMSHAFT 2	1	1	1	FOR RH
29	90101-06046	BOLT	1	1	1	
30	95302-06600	NUT	1	1	1	
31	52H-2513A-00	PLATE, INDICATOR	1	1	1	
32	93210-12327	O-RING	2	2	2	
33	93102-40367	OIL SEAL	1	1	1	

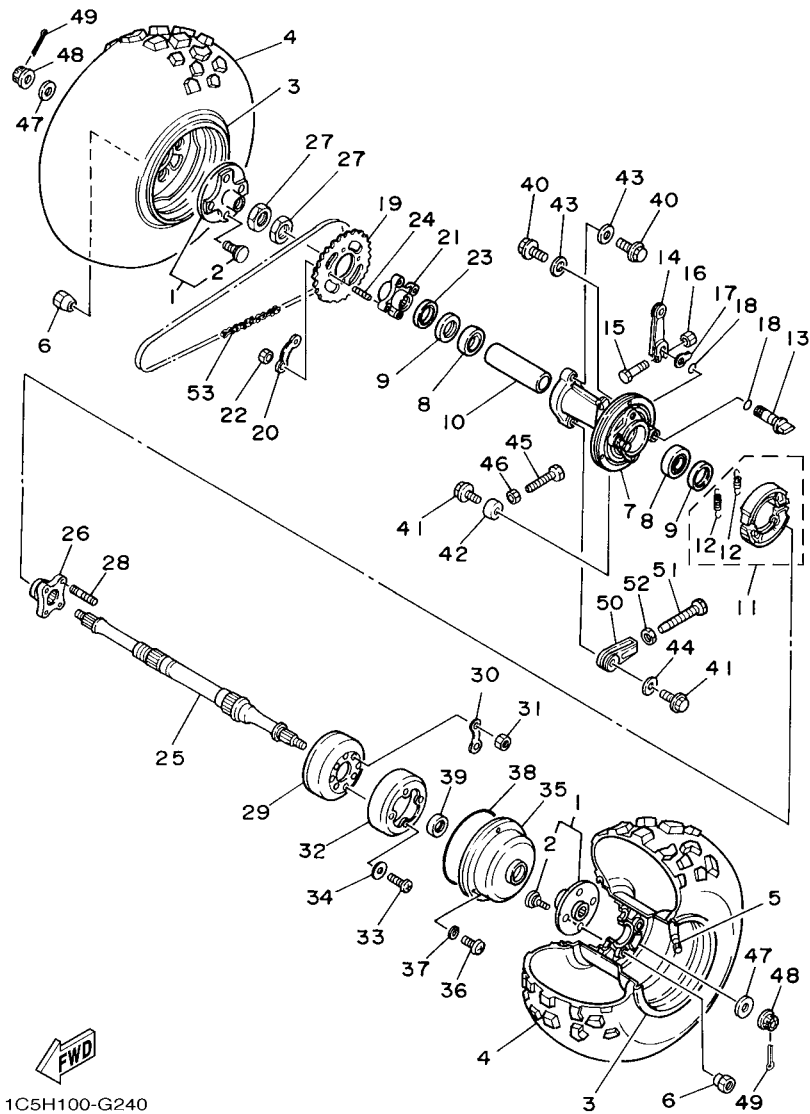

1C5H100-G240

FIG. 24 REAR WHEEL

REF. NO.	PART NO.	DESCRIPTION	CAN	EUR	JPN	REMARKS
1	1C5-25383-00	COLLAR, WHEEL	2	2	2	
2	90114-10014	.BOLT, SERRATION	4	4	4	
3	3FA-25390-00-98	REAR WHEEL COMP.	2	2	2	LGB
4	94110-08008	TIRE (AT22X10-8*KT537A T/L N)	2	2	2	DUNLOP
5	93900-00022	VALVE, RIM (TR413)	2	2	2	TAIHEIYO
6	90179-10022	NUT	8	8	8	
7	3FA-25311-00	HUB, REAR	1	1	1	
8	93306-00710	BEARING	2	2	2	
9	93102-42260	OIL SEAL	2	2	2	
10	3FA-25317-00	SPACER, BEARING	1	1	1	
11	3FA-W253A-00	BRAKE SHOE KIT	1	1	1	
12	90506-15260	.SPRING, TENSION	2	2	2	
13	55X-25351-00	CAMSHAFT	1	1	1	
14	2N3-25155-00	LEVER, CAMSHAFT 1	1	1	1	
15	90101-06046	BOLT	1	1	1	
16	95302-06600	NUT	1	1	1	
17	23F-2533A-00	PLATE, INDICATOR	1	1	1	
18	93210-14104	O-RING	2	2	2	
19	3FA-25432-20	SPROCKET, DRIVEN (32T)	1	1	1	
20	10V-25412-00	WASHER	2	2	2	
21	3FA-25386-00	COLLAR, SPROCKET AXLE	1	1	1	
22	90170-10011	NUT	4	4	4	
23	5V6-25367-00	COVER, HUB DUST	1	1	1	
24	90116-10042	BOLT, STUD	4	4	4	
25	3FA-25381-10	AXLE, WHEEL	1	1	1	
26	3FA-25343-00	BOSS	1	1	1	
27	90170-33011	NUT	2	2	2	

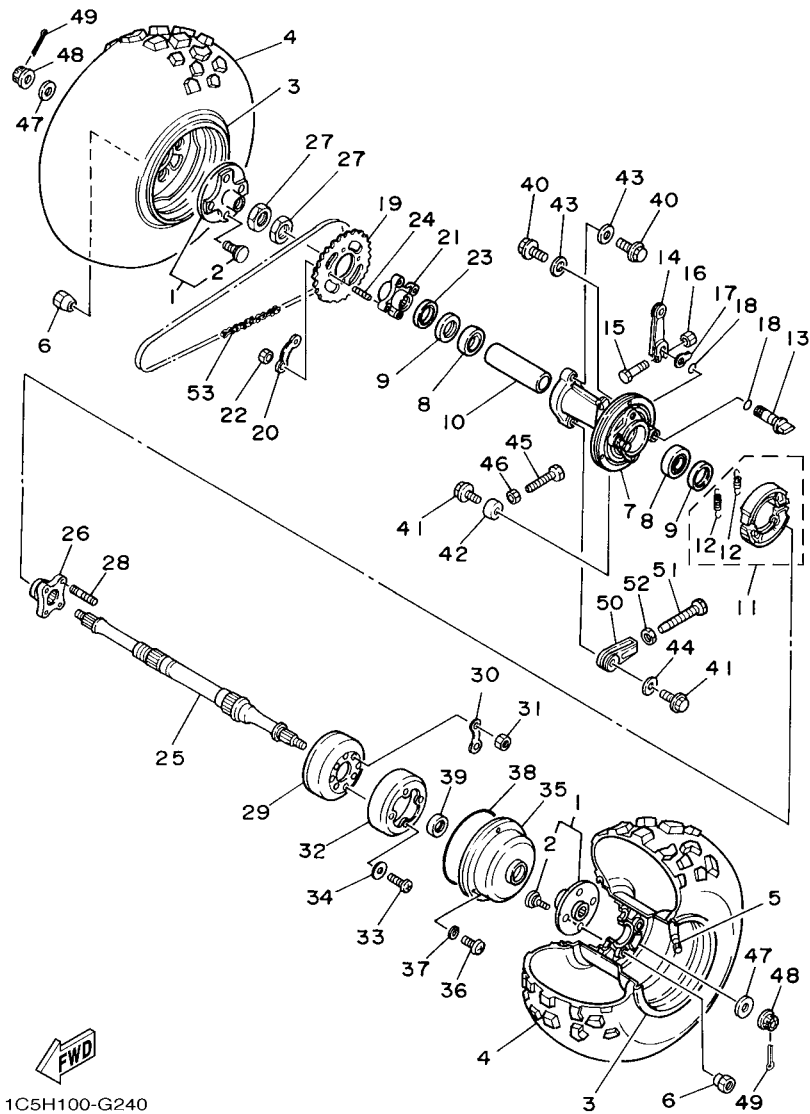

1C5H100-G240

FIG. 24 REAR WHEEL

REF. NO.	PART NO.	DESCRIPTION	CAN	EUR	JPN	REMARKS
28	90116-08084	BOLT, STUD	4	4	4	
29	3FA-2531E-00	DRUM, BRAKE	1	1	1	
30	390-25412-01	WASHER	2	2	2	
31	95302-08600	NUT	4	4	4	
32	3FA-25336-00	RING 2	1	1	1	
33	98502-05010	SCREW, PAN HEAD	4	4	4	
34	92902-05600	WASHER, PLATE	4	4	4	
35	55X-25715-00	COVER 1	1	1	1	
36	92502-06012	SCREW, PAN HEAD	3	3	3	
37	92902-06600	WASHER, PLATE	3	3	3	
38	93211-63688	O-RING	1	1	1	
39	93102-35349	OIL SEAL	1	1	1	
40	90105-12060	BOLT, FLANGE	2	2	2	
41	90105-10280	BOLT, FLANGE	2	2	2	
42	90387-113W0	COLLAR	1	1	1	
43	90201-12048	WASHER, PLATE	2	2	2	
44	90201-10052	WASHER, PLATE	1	1	1	
45	90101-08056	BOLT	1	1	1	
46	95302-08600	NUT	1	1	1	
47	90201-14021	WASHER, PLATE	2	2	2	
48	90171-14004	NUT, CASTLE	2	2	2	
49	91401-30030	PIN, COTTER	2	2	2	
50	1UY-25388-00	PULLER, CHAIN 1	1	1	1	
51	90101-08647	BOLT	1	1	1	
52	95302-08600	NUT	1	1	1	
53	94582-02074	CHAIN (DID520V 74L)	1	1	1	

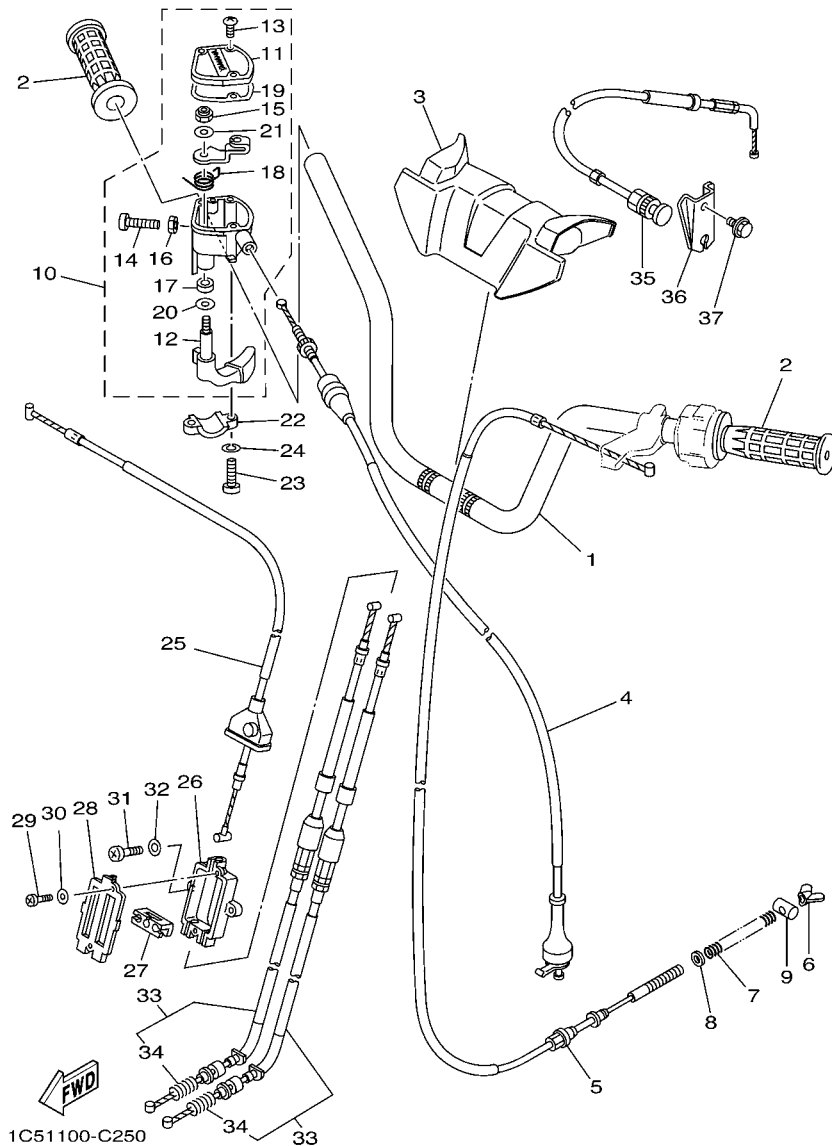
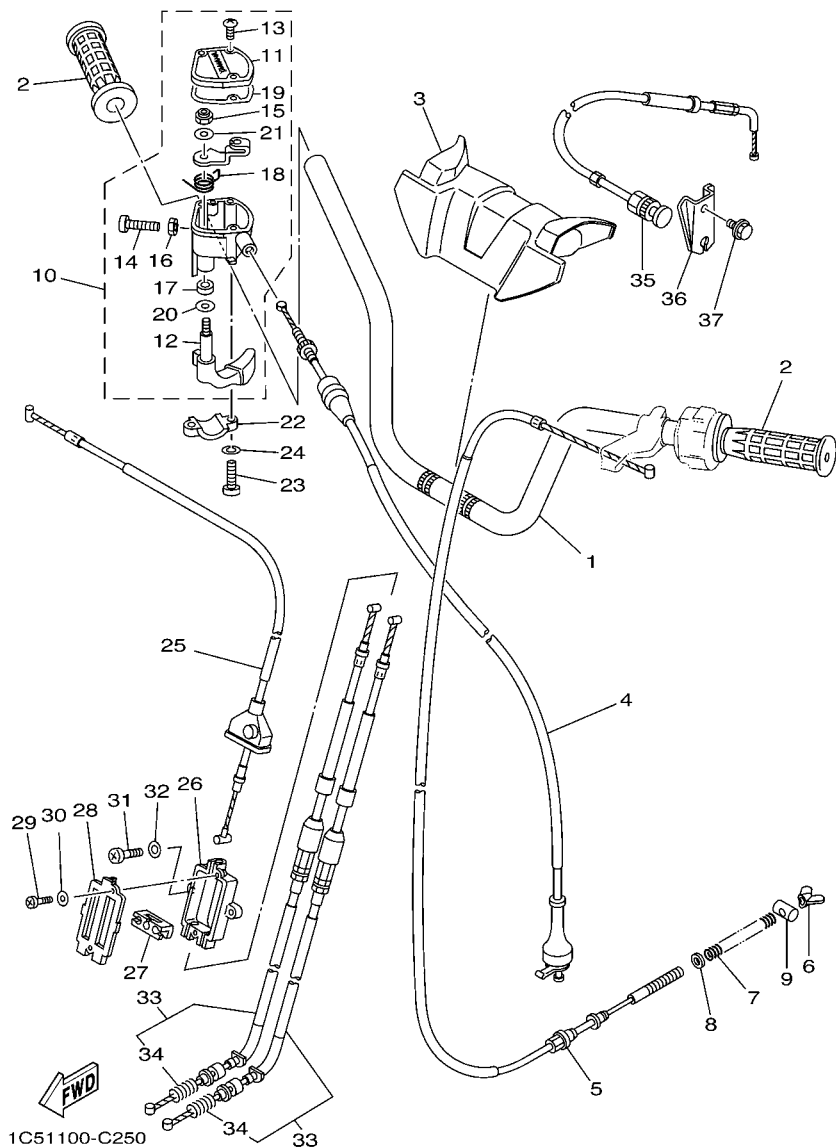

FIG. 25 STEERING HANDLE & CABLE

REF. NO.	PART NO.	DESCRIPTION	CAN	EUR	JPN	REMARKS
1	3FA-26111-20	HANDLEBAR	1	1	1	
2	3GB-26241-00	GRIP	2	2	2	
3	1C5-26124-00	PROTECTOR, HANDLEBAR	1	1	1	
4	3FA-26311-10	CABLE, THROTTLE 1	1	1	1	
5	3FA-26351-03	CABLE, BRAKE	1	1	1	
6	90175-06013	NUT, WING	1	1	1	
7	90501-122E1	SPRING, COMPRESSION	1	1	1	
8	90202-08175	WASHER, PLATE	1	1	1	
9	90249-12008	PIN	1	1	1	
10	4KB-26250-11	THROTTLE LEVER ASSY	1	1	1	
11	4KB-2628F-10	.CAP, GEAR	1	1	1	
12	1NV-2625G-01	.LEVER, THROTTLE	1	1	1	
13	90149-04278	.SCREW	3	3	3	
14	98507-05020	.SCREW, PAN HEAD	1	1	1	
15	95602-05100	.NUT, U	1	1	1	
16	95307-05700	.NUT	1	1	1	
17	93104-09025	.OIL SEAL	1	1	1	
18	1NV-26304-00	.SPRING	1	1	1	
19	4KB-2628G-00	.GASKET	1	1	1	
20	1NV-26129-00	.WASHER	1	1	1	
21	1NV-26398-00	.WASHER	1	1	1	
22	1S3-82913-00	HOLDER, LEVER LOWER 1	1	1	1	
23	98502-05020	SCREW, PAN HEAD	2	2	2	
24	92902-05600	WASHER, PLATE	2	2	2	
25	3FA-26373-00	CABLE, BRAKE 4	1	1	1	
26	52H-26371-00	HOUSING, BRAKE LINK	1	1	1	
27	52H-26347-01	JOINT, CABLE	1	1	1	

FIG. 25 STEERING HANDLE & CABLE



REF. NO.	PART NO.	DESCRIPTION	CAN	EUR	JPN	REMARKS
28	52H-2631G-00	PLATE	1	1	1	
29	98502-03008	SCREW, PAN HEAD	2	2	2	
30	92902-03600	WASHER, PLATE	2	2	2	
31	98502-05016	SCREW, PAN HEAD	2	2	2	
32	92902-05600	WASHER, PLATE	2	2	2	
33	3FA-26361-10	CABLE, BRAKE	2	2	2	
34	90501-08511	.SPRING, COMPRESSION	1	1	1	
35	3FA-26331-01	CABLE, STARTER 1	1	1	1	
36	1C5-26393-00	HOLDER	1	1	1	
37	95822-06010	BOLT, FLANGE	1	1	1	

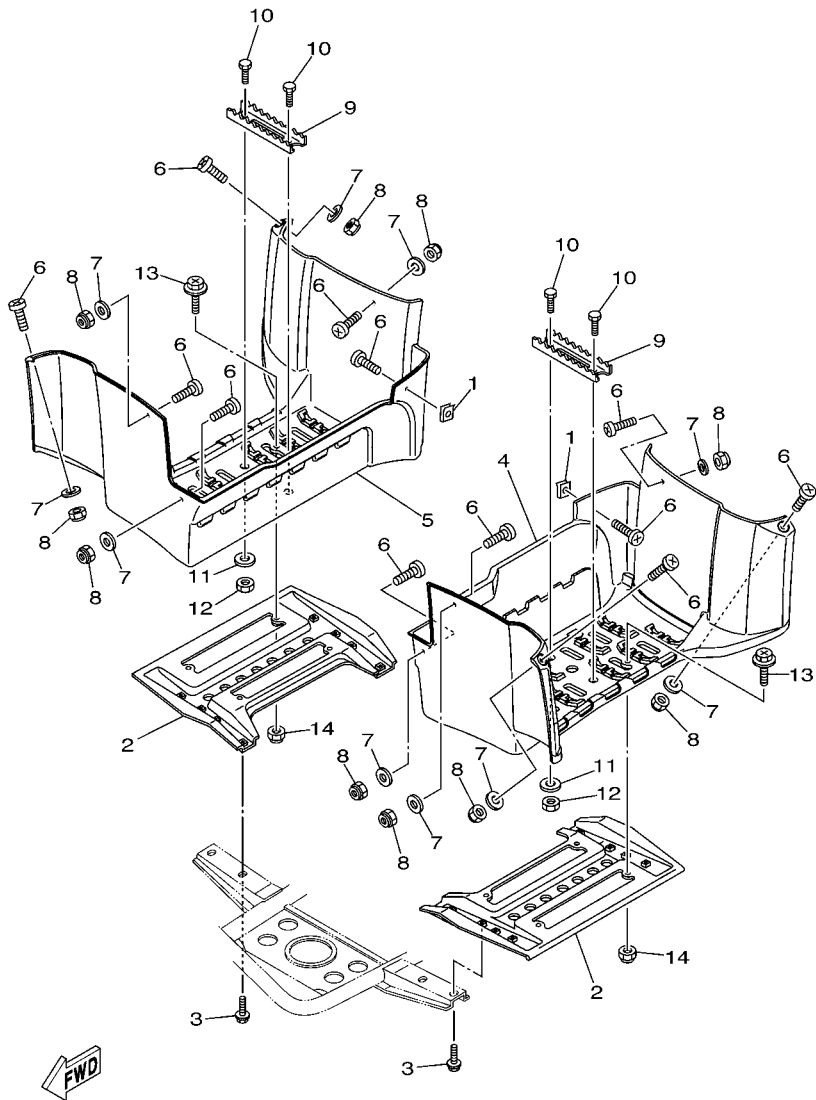

1C51100-C260

FIG. 26 STAND & FOOTREST

REF. NO.	PART NO.	DESCRIPTION	CAN	EUR	JPN	REMARKS
1	90183-06053	NUT, SPRING	2	2	2	
2	3FA-27411-10	FOOTREST 1	2	2	2	
3	95812-08014	BOLT, FLANGE	8	8	8	
4	1C5-27453-00	COVER 1	1	1	1	
5	1C5-27463-00	COVER 2	1	1	1	
6	98902-06020	SCREW, BIND	12	12	12	
7	90201-06032	WASHER, PLATE	10	10	10	
8	95702-06300	NUT, NYLON	10	10	10	
9	5GH-2741A-10	ARM 1	2	2	2	
10	90109-06214	BOLT	4	4	4	
11	90201-06033	WASHER, PLATE	4	4	4	
12	95312-06600	NUT	4	4	4	
13	90119-05021	BOLT, WITH WASHER	8	8	8	
14	95702-05300	NUT, NYLON	8	8	8	

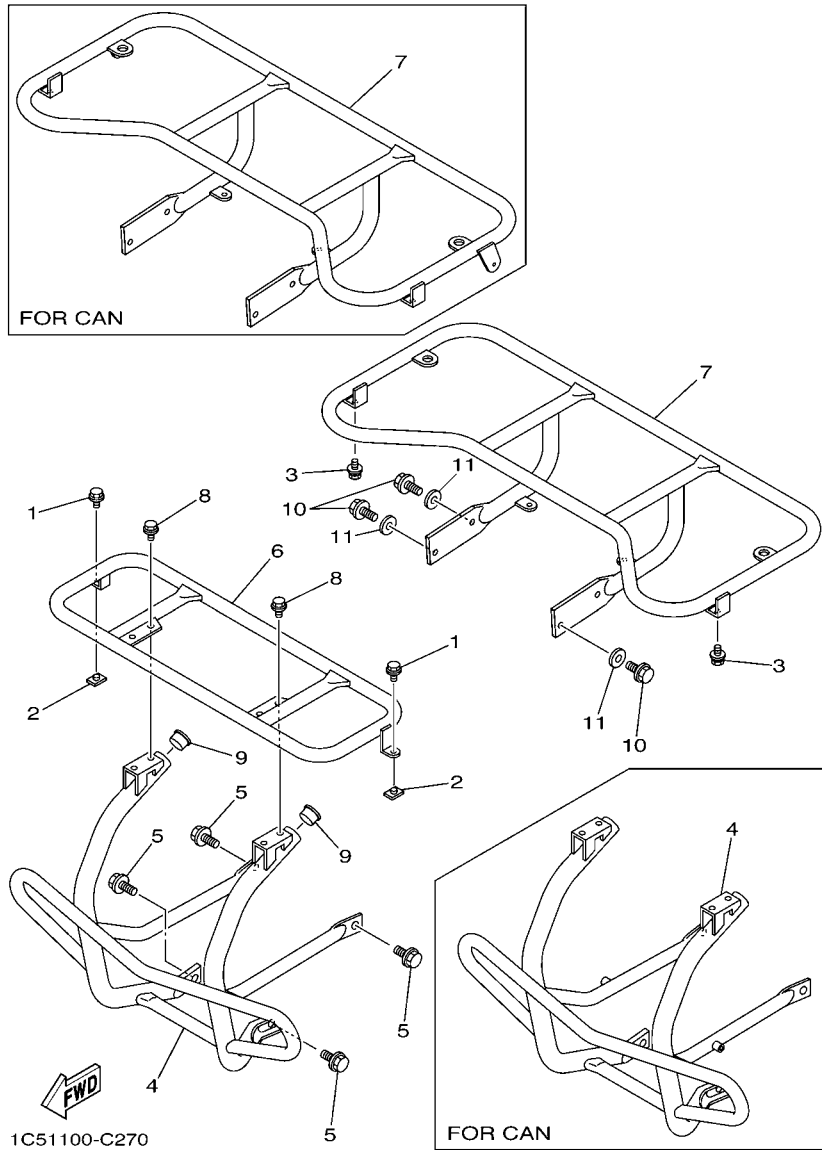
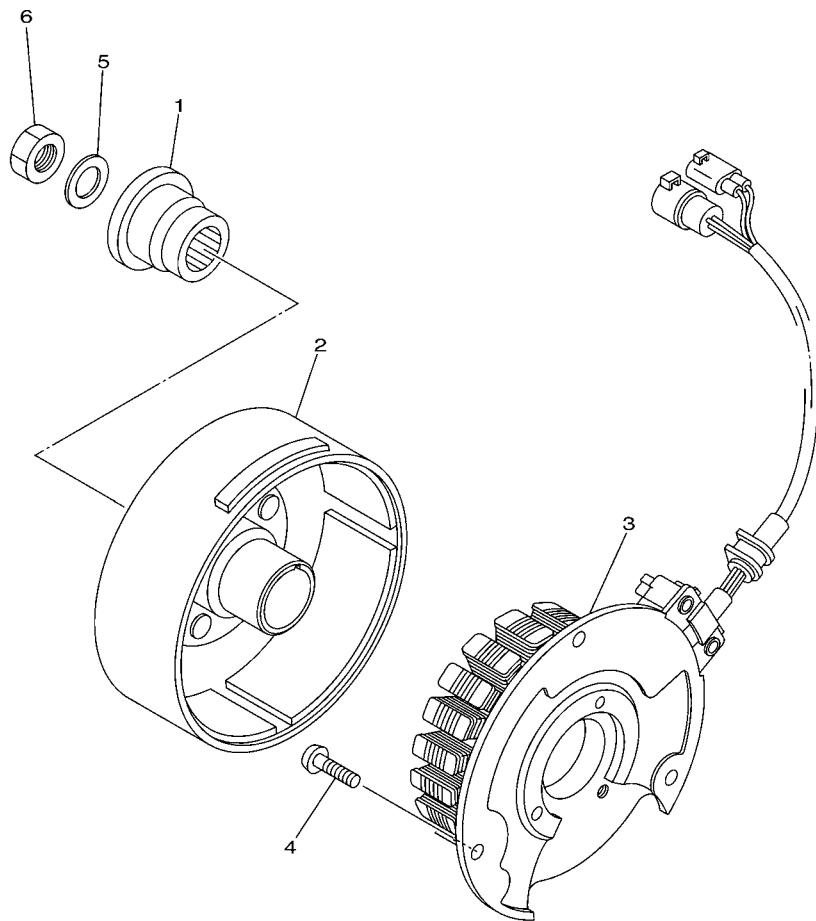

FIG. 27 GUARD

REF. NO.	PART NO.	DESCRIPTION	CAN	EUR	JPN	REMARKS
1	95802-06010	BOLT, FLANGE	2	2	2	
2	90179-06055	NUT	2	2	2	
3	90119-06152	BOLT, WITH WASHER	2	2	2	
4	1C5-2845N-10	BAR, CARRY FRONT	1			
	1C5-2845N-00	BAR, CARRY FRONT		1	1	
5	95812-08016	BOLT, FLANGE	4	4	4	
6	1C5-24841-00	CARRIER, FRONT	1	1	1	
7	1C5-24842-10	CARRIER, REAR	1			
	1C5-24842-00	CARRIER, REAR		1	1	
8	95802-06010	BOLT, FLANGE	4	4	4	
9	90338-23172	PLUG	2	2	2	
10	95812-08016	BOLT, FLANGE	3	3	3	
11	90201-08043	WASHER, PLATE	3	3	3	



1C51100-C280

FIG. 28 GENERATOR

REF. NO.	PART NO.	DESCRIPTION	CAN	EUR	JPN	REMARKS
1	3FA-15724-00	SPACER	1	1	1	
2	1C5-81450-01	ROTOR ASSY	1	1	1	
3	1C5-81410-00	STATOR ASSY	1	1	1	
4	92012-06020	BOLT, BUTTON HEAD	3	3	3	
5	90201-12030	WASHER, PLATE	1	1	1	
6	90170-12181	NUT	1	1	1	

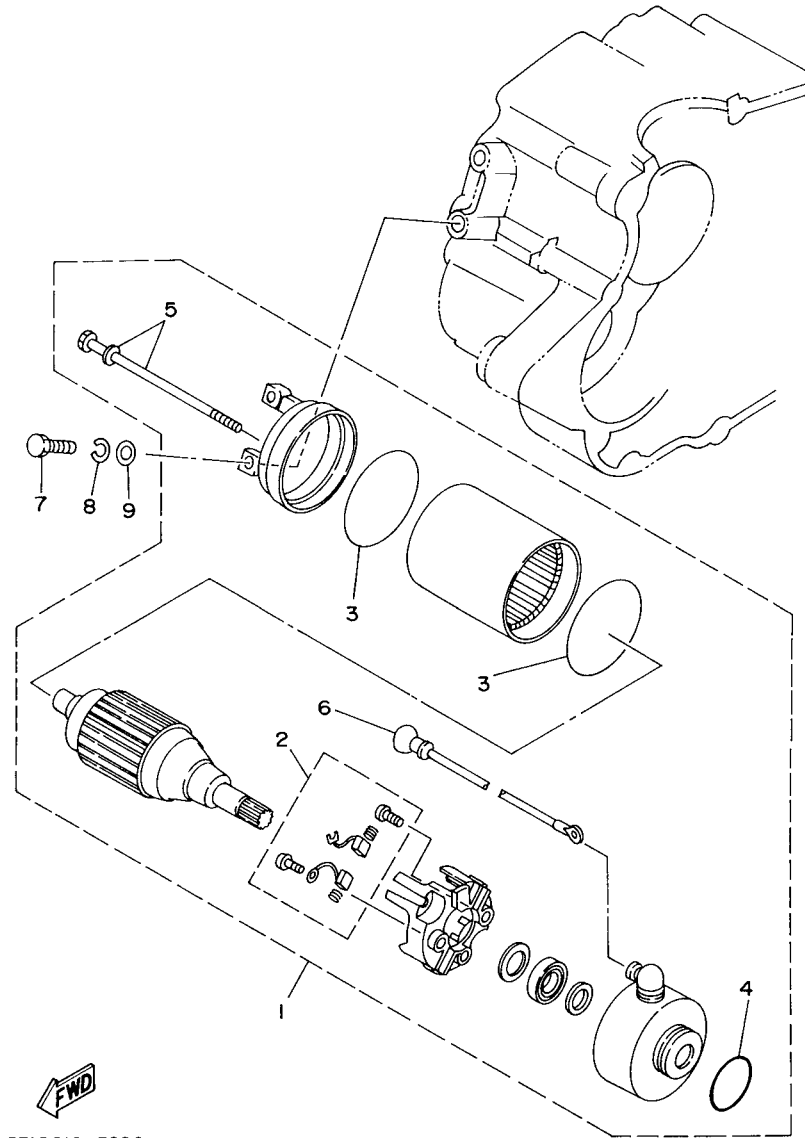

3FA9010-3290

FIG. 29 STARTING MOTOR

REF. NO.	PART NO.	DESCRIPTION	CAN	EUR	JPN	REMARKS
1	3FA-81800-01	STARTING MOTOR ASSY	1	1	1	
2	50M-81801-M0	.BRUSH SET	1	1	1	
3	93210-55669	.O-RING	2	2	2	
4	93210-25711	.O-RING	1	1	1	
5	3FA-81828-00	.SCREW 2	2	2	2	
6	3FA-8183G-00	.CORD COMP.	1	1	1	
7	97002-06025	BOLT	2	2	2	
8	92902-06100	WASHER, SPRING	2	2	2	
9	92902-06600	WASHER, PLATE	2	2	2	

FIG. 30 HEADLIGHT

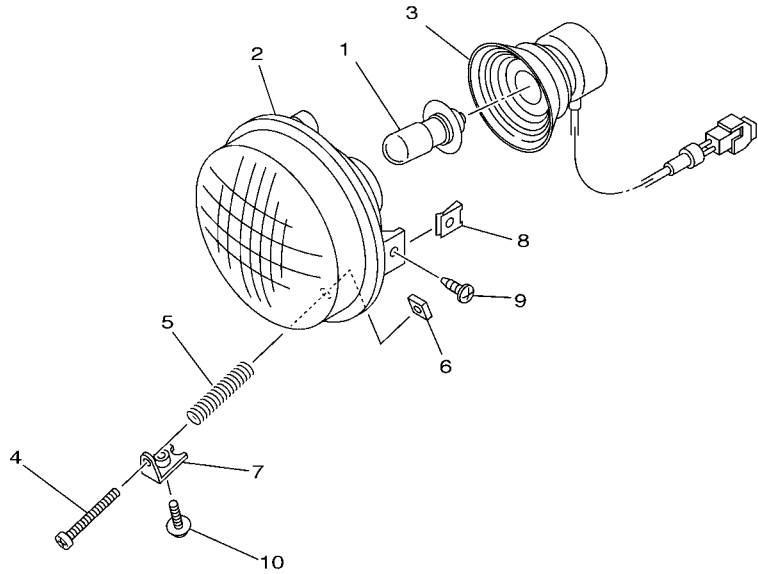

5KM1100-2450

REF. NO.	PART NO.	DESCRIPTION	CAN	EUR	JPN	REMARKS
1	4KB-84314-01	BULB (12V-30/30W)	2	2	2	
2	5KM-84320-01	LENS ASSY	2	2	2	
3	5EH-84340-00	SOCKET CORD ASSY 1	2	2	2	
4	98502-03540	SCREW, PAN HEAD	2	2	2	
5	2GU-84332-00	SPRING, SCREW	2	2	2	
6	2GU-84334-00	NUT, ADJUSTING	2	2	2	
7	5KM-84703-10	BRACKET	2	2	2	
8	90183-05008	NUT, SPRING	4	4	4	
9	90154-05021	SCREW, BINDING	4	4	4	
10	90159-05044	SCREW, WITH WASHER	2	2	2	

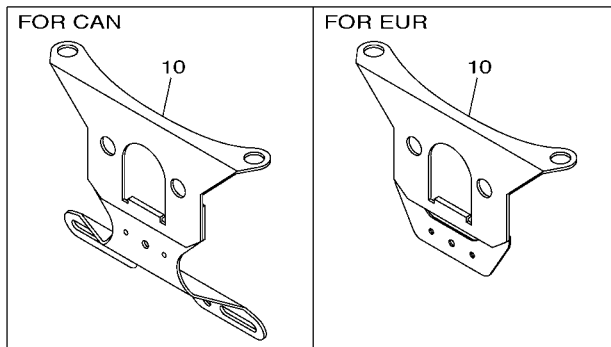
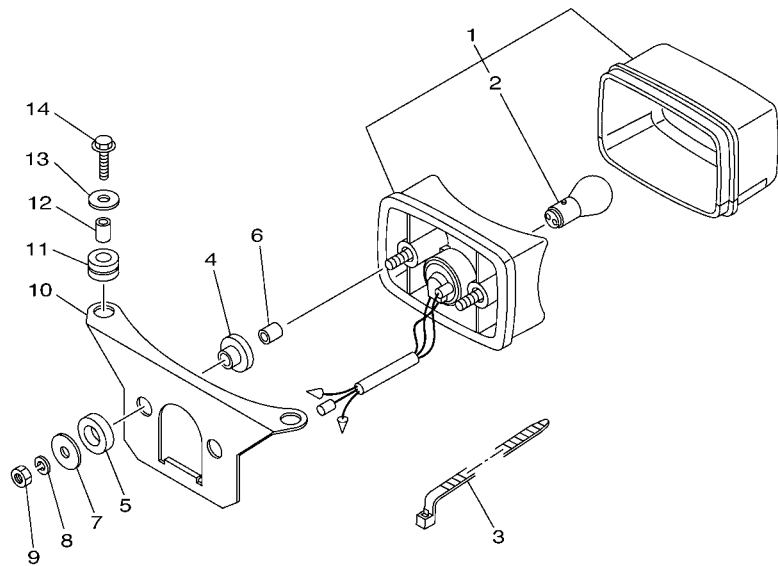

1C5H100-G310

FIG. 31 TAILLIGHT

REF. NO.	PART NO.	DESCRIPTION	CAN	EUR	JPN	REMARKS
1	3FA-84710-00	TAILLIGHT UNIT ASSY	1	1	1	
2	1A2-84714-41	.BULB (12V-21/5W)	1	1	1	
3	90464-15195	CLAMP	1	1	1	
4	90480-14088	GROMMET	2	2	2	
5	90202-14077	WASHER, PLATE	2	2	2	
6	90387-06201	COLLAR	2	2	2	
7	90201-06097	WASHER, PLATE	2	2	2	
8	92902-06100	WASHER, SPRING	2	2	2	
9	95302-06600	NUT	2	2	2	
10	3FA-84702-20	BRACKET, TAILLIGHT	1			
	3FA-84702-30	BRACKET, TAILLIGHT		1		
	3FA-84702-10	BRACKET, TAILLIGHT			1	
11	90480-14555	GROMMET	2	2	2	
12	90387-065L7	COLLAR	2	2	2	
13	90201-06033	WASHER, PLATE	2	2	2	
14	95802-06025	BOLT, FLANGE	2	2	2	

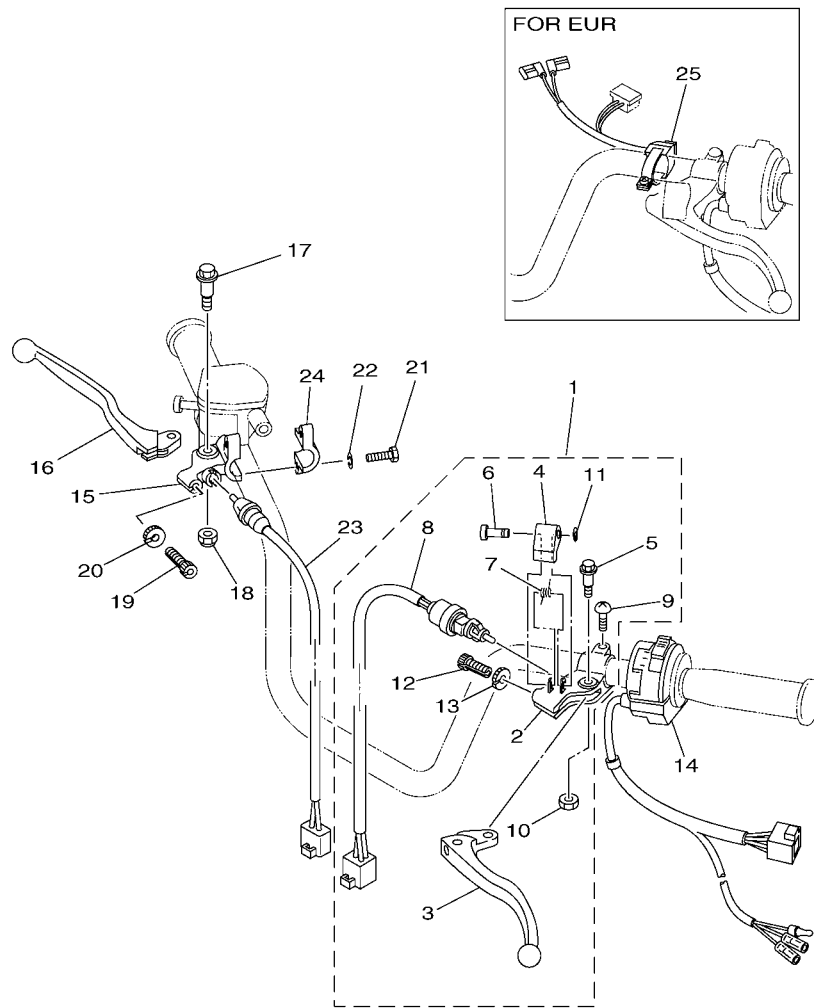

1PY2100-L320

FIG. 32 HANDLE SWITCH & LEVER

REF. NO.	PART NO.	DESCRIPTION	CAN	EUR	JPN	REMARKS
1	3FA-82910-30	LEVER HOLDER ASSY (LEFT)	1	1	1	
2	3FA-82911-20	.HOLDER, LEVER 1	1	1	1	
3	2HT-83912-00	.LEVER 1	1	1	1	
4	3FA-83965-10	.LEVER, LOCK	1	1	1	
5	90109-06798	.BOLT	1	1	1	
6	3FA-83967-00	.PIN, LOCK 1	1	1	1	
7	3FA-83966-00	.SPRING, RETURN	1	1	1	
8	3FA-83980-03	.FRONT STOP SWITCH ASSY	1	1	1	
9	98502-06020	.SCREW, PAN HEAD	1	1	1	
10	95602-06100	.NUT, U	1	1	1	
11	3FA-26466-00	.RING, SNAP	1	1	1	
12	90123-08002	.BOLT	1	1	1	
13	90179-08030	.NUT	1	1	1	
14	4KB-83973-21	SWITCH, HANDLE 3	1	1	1	
15	3JN-82921-10	HOLDER, LEVER 2	1	1	1	
16	59V-83922-00	LEVER 2	1	1	1	
17	90109-06798	BOLT	1	1	1	
18	95602-06100	NUT, U	1	1	1	
19	90123-08002	BOLT	1	1	1	
20	90179-08030	NUT	1	1	1	
21	97022-06025	BOLT	2	2	2	
22	92902-06100	WASHER, SPRING	2	2	2	
23	3FA-83980-10	FRONT STOP SWITCH ASSY	1	1	1	
24	5LP-82913-11	HOLDER, LEVER LOWER 1	1	1	1	
25	1C5-83976-00	SWITCH, HANDLE 1			1	

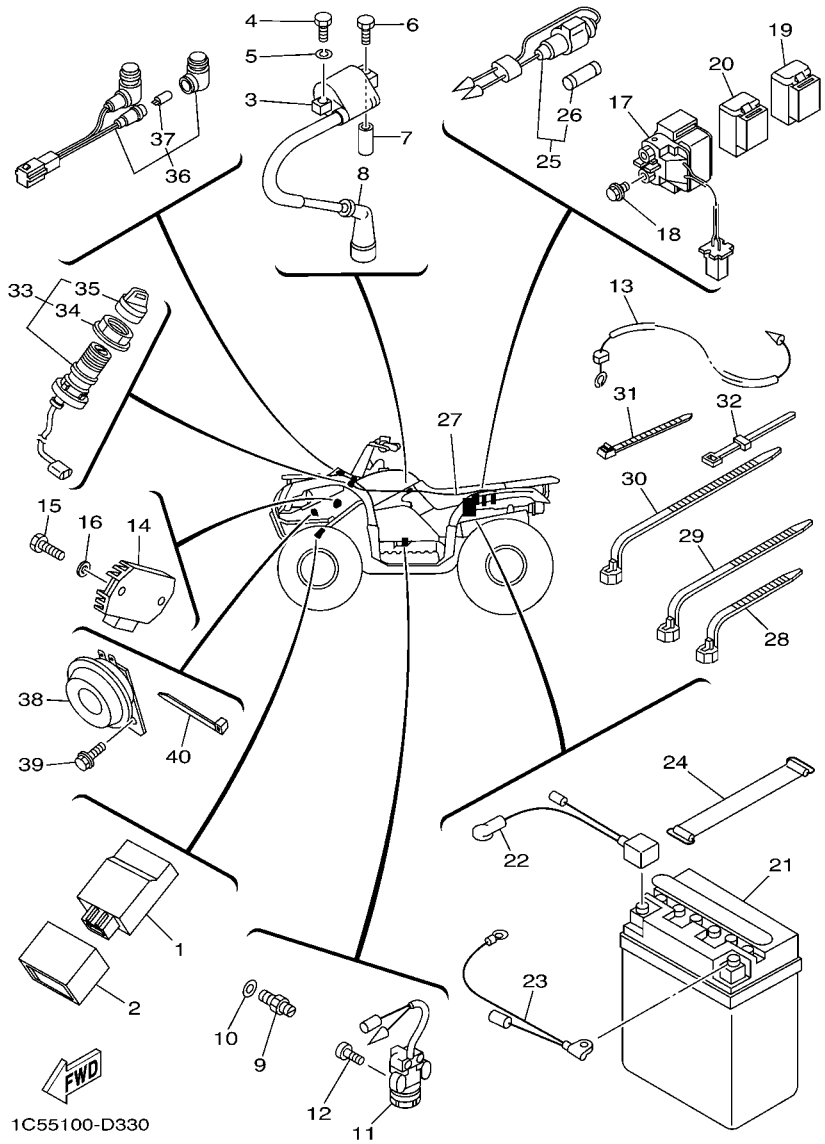

FIG. 33 ELECTRICAL 1

REF. NO.	PART NO.	DESCRIPTION	CAN	EUR	JPN	REMARKS
1	3FA-85540-20	C.D.I. UNIT ASSY	1	1	1	
2	5HP-85546-00	BAND	1	1	1	
3	4KJ-82310-10	IGNITION COIL ASSY	1	1	1	
4	97002-06020	BOLT	1	1	1	
5	92902-06100	WASHER, SPRING	1	1	1	
6	90109-06723	BOLT	1	1	1	
7	90445-072A4	HOSE (L15)	1	1	1	
8	1UY-82370-20	PLUG CAP ASSY	1	1	1	
9	4KM-82540-00	NEUTRAL SWITCH ASSY	1	1	1	
10	90430-10148	GASKET	1	1	1	
11	3FA-82627-00	SWITCH	1	1	1	
12	90149-05024	SCREW	2	2	2	
13	3FA-82541-00	WIRE, LEAD	1	1	1	
14	5GT-81960-00	RECTIFIER & REGULATOR ASSY	1	1	1	
15	97002-06020	BOLT	2	2	2	
16	92902-06600	WASHER, PLATE	2	2	2	
17	3MW-81940-01	STARTER RELAY ASSY	1	1	1	
18	95022-06008	BOLT, FLANGE	2	2	2	
19	29U-81950-93	RELAY ASSY	1	1	1	
20	2NL-81950-92	RELAY ASSY	1	1	1	
21	3FA-82110-12	BATTERY ASSY (GS 12N12C-4A-2)	1	1		
	90793-26276	BATTERY ASSY (GS 12N12C-4A-2)			1	
22	3FA-82115-01	WIRE, PLUS LEAD	1	1	1	
23	3FA-82116-00	WIRE, MINUS LEAD	1	1	1	
24	133-82131-00	BAND, BATTERY	1	1	1	
25	1UY-82150-00	FUSE HOLDER ASSY	1	1	1	
26	1UY-82151-00	.FUSE (15A)	2	2	2	

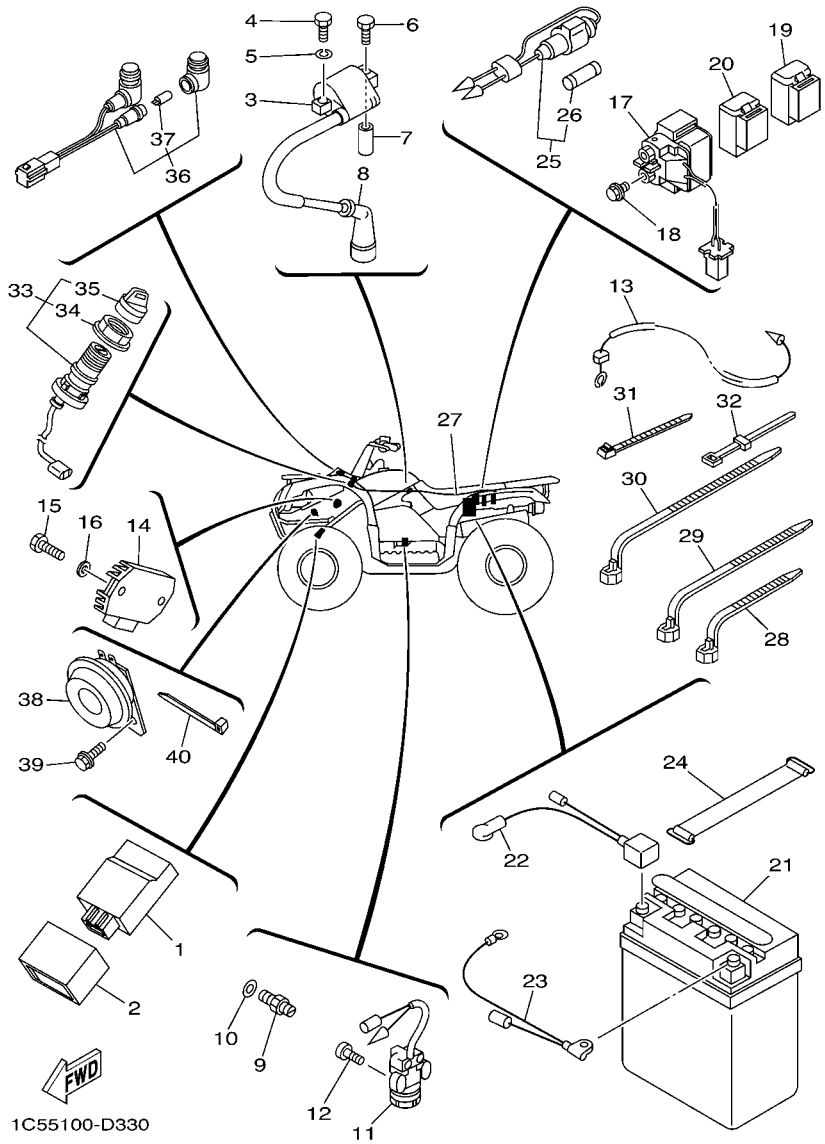
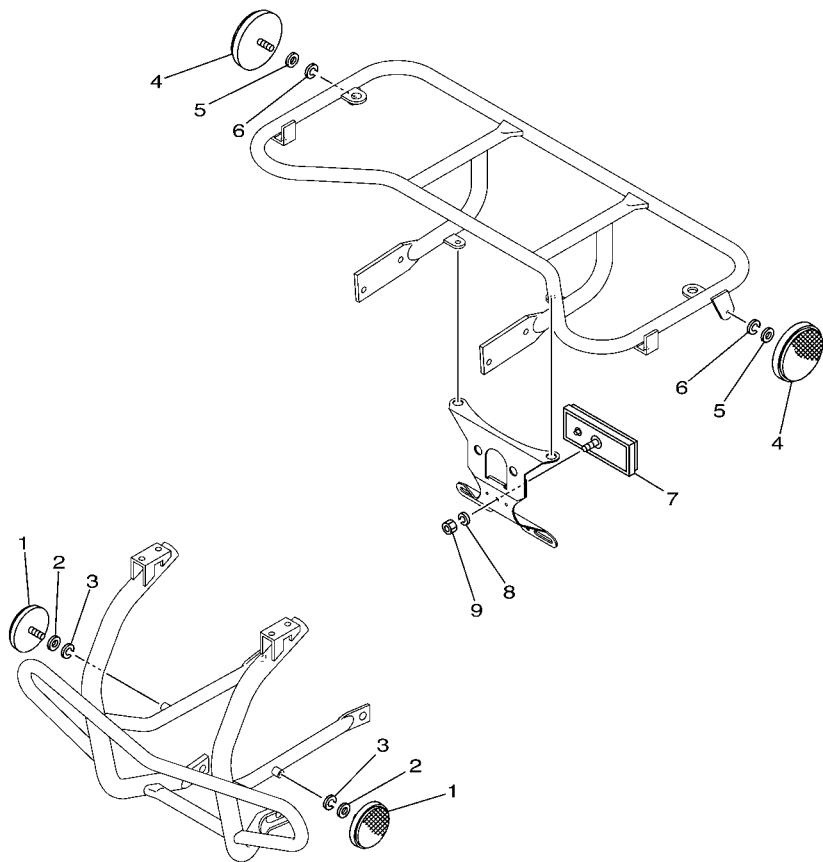

FIG. 33 ELECTRICAL 1

REF. NO.	PART NO.	DESCRIPTION	CAN	EUR	JPN	REMARKS
27	1C5-82590-00	WIRE HARNESS ASSY	1		1	
	1C5-82590-10	WIRE HARNESS ASSY		1		
28	90464-13073	CLAMP	4	4	4	
29	90464-15195	CLAMP	1	1	1	
30	90464-12045	CLAMP	1	1	1	
31	90465-10098	CLAMP	1	1	1	
32	437-83936-01	BAND, SWITCH CORD	4	4	4	
33	5LP-82510-00	MAIN SWITCH ASSY	1	1	1	
34	3HN-82569-00	.NUT, MAIN SWITCH	1	1	1	
35	3HN-82579-00	.CAP, KEY	1	1	1	
36	5TE-83530-00	PILOT LIGHT ASSY	1	1	1	
37	5GH-83516-00	.BULB (14V-1.7W)	2	2	2	
38	50M-83371-20	HORN		1		
39	95812-06012	BOLT, FLANGE		1		
40	90464-35132	CLAMP		1		

FIG. 34 ELECTRICAL 2



1C51100-C340

REF. NO.	PART NO.	DESCRIPTION	CAN	EUR	JPN	REMARKS
1	2EK-85111-00	REFLECTOR, FRONT 1	2			
2	92902-05200	WASHER	2			
3	92902-05100	WASHER, SPRING	2			
4	449-85131-02	REFLECTOR, REAR 1	2			
5	92902-05200	WASHER	2			
6	92902-05100	WASHER, SPRING	2			
7	3Y6-85130-02	REAR REFLECTOR ASSY	1	1		
8	92902-05100	WASHER, SPRING	1	1		
9	95302-05600	NUT	1	1		

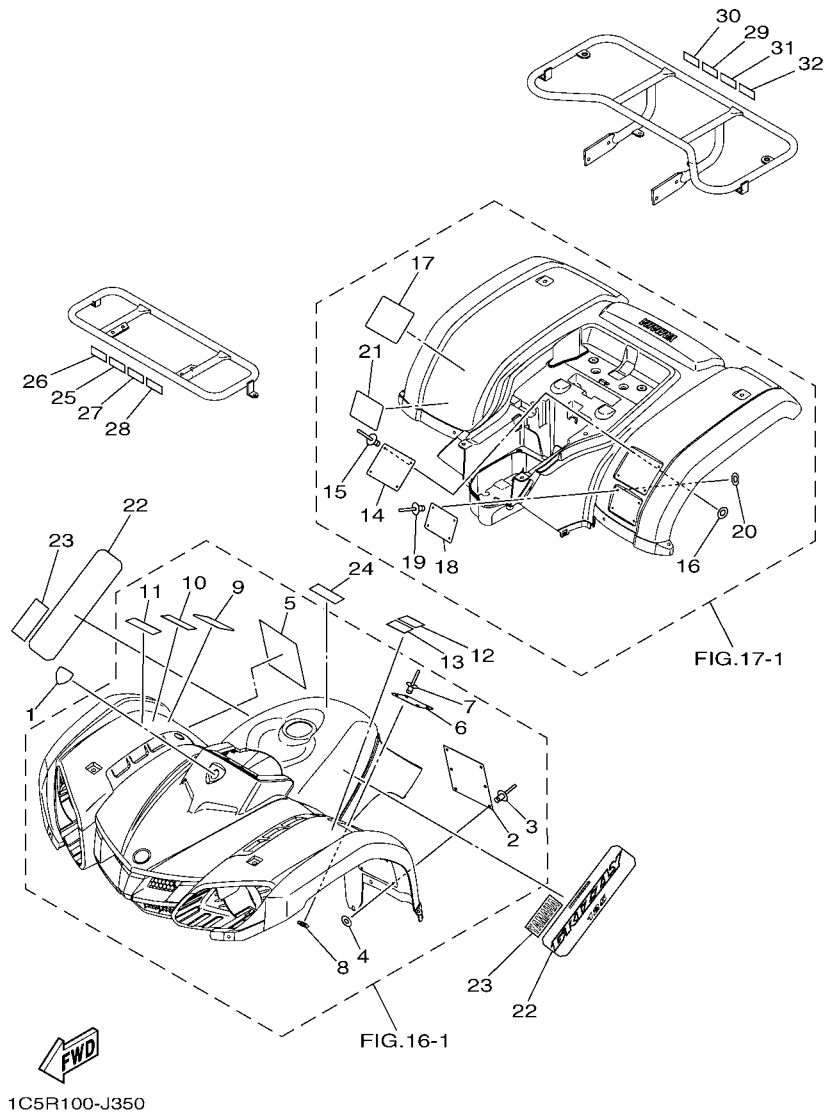

FIG. 35 EMBLEM & LABEL 1

REF. NO.	PART NO.	DESCRIPTION	CAN	EUR	JPN	REMARKS
1	3B4-26232-01	EMBLEM 3D	1			
2	5FE-21568-01	LABEL, WARNING	1			ENGLISH
3	90267-32004	RIVET, BLIND	6			
4	90201-03008	WASHER, PLATE	6			
5	4WU-21568-10	LABEL, WARNING	1			FRENCH
6	4D3-2816L-00	LABEL, WARNING AGE	1			ENGLISH
7	90267-32004	RIVET, BLIND	4			
8	90201-03008	WASHER, PLATE	4			
9	4D3-2816L-10	LABEL, WARNING AGE	1			FRENCH
10	5YT-2151E-30	LABEL 2	1			ENGLISH
11	5YT-2151E-40	LABEL 2	1			FRENCH
12	4D3-2817J-20	PLATE, ANSI SVIA	1			ENGLISH
13	4D3-2817J-30	PLATE, ANSI SVIA	1			FRENCH
14	1C5-2816M-00	LABEL, WARNING TIRE & LOAD	1			ENGLISH
15	90267-32004	RIVET, BLIND	4			
16	90201-03008	WASHER, PLATE	4			
17	1C5-2816M-10	LABEL, WARNING TIRE & LOAD	1			FRENCH
18	5FE-2151H-01	LABEL 5	1			ENGLISH
19	90267-32004	RIVET, BLIND	4			
20	90201-03008	WASHER, PLATE	4			
21	4WU-2151H-10	LABEL 5	1			FRENCH
22	1C5-2173E-H0	GRAPHIC, 1	2			
23	4ES-2153E-30	EMBLEM, YAMAHA	2			
24	4SH-2416E-00	LABEL, CAUTION CANADA	1			ENGLISH
25	3MX-24875-A0	LABEL 1	1			ENGLISH
26	3MX-24875-B0	LABEL 1	1			FRENCH
27	3LD-24877-A0	LABEL, CAUTION	1			ENGLISH

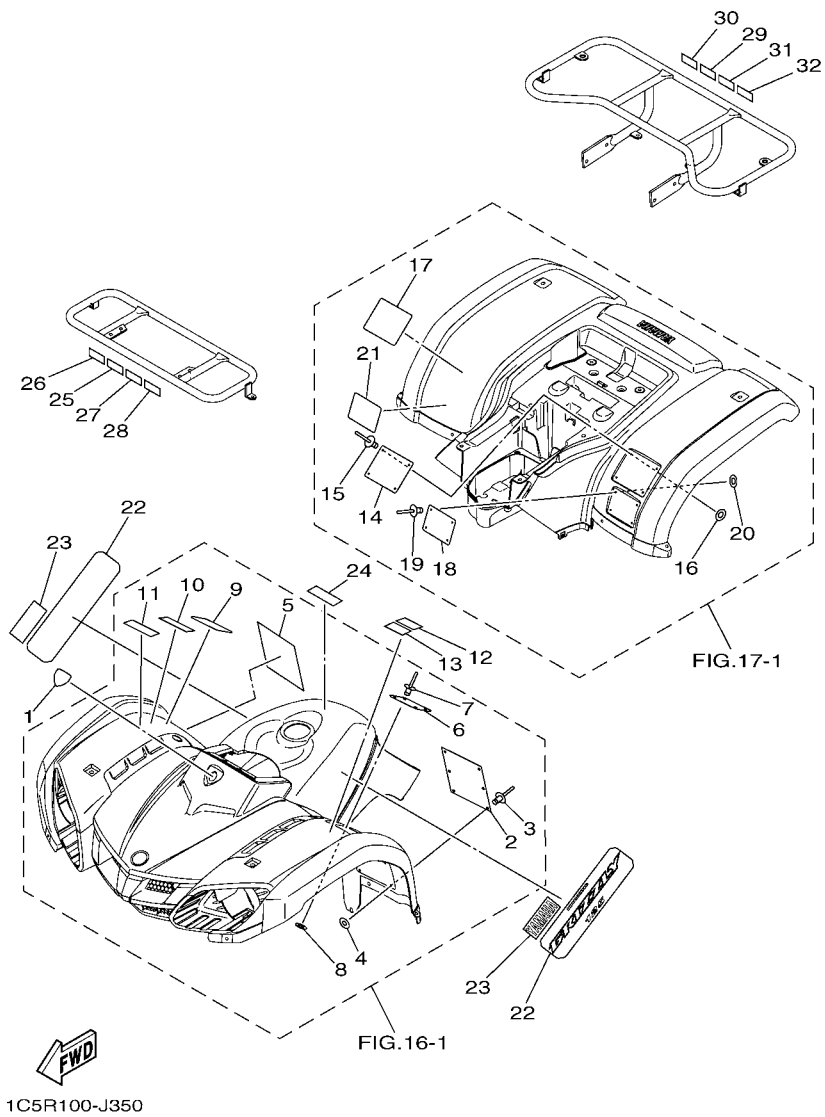

FIG. 35 EMBLEM & LABEL 1

REF. NO.	PART NO.	DESCRIPTION	CAN	EUR	JPN	REMARKS
28	3LD-24877-B1	LABEL, CAUTION	1			FRENCH
29	3MX-24875-A0	LABEL 1	1			ENGLISH
30	3MX-24875-B0	LABEL 1	1			FRENCH
31	1C5-24877-A0	LABEL, CAUTION	1			ENGLISH
32	1C5-24877-B1	LABEL, CAUTION	1			FRENCH

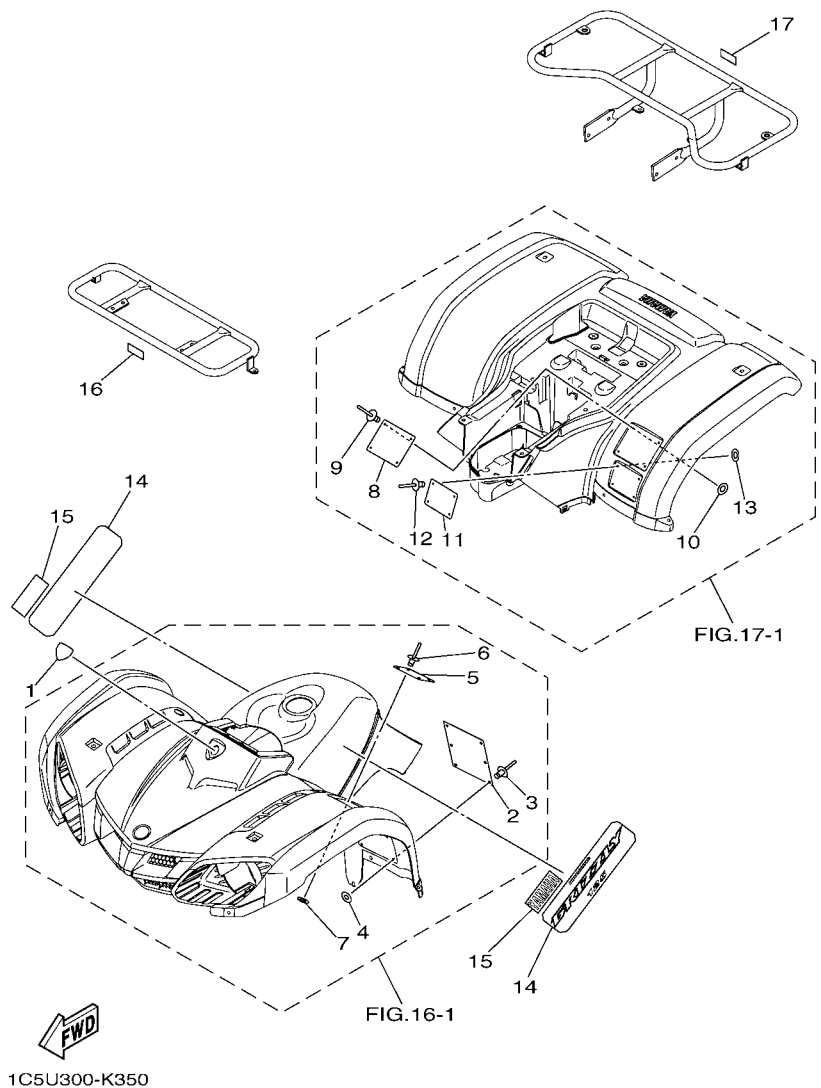

FIG. 36 EMBLEM & LABEL 2

REF. NO.	PART NO.	DESCRIPTION	CAN	EUR	JPN	REMARKS
1	3B4-26232-01	EMBLEM 3D		1		
2	43P-2816R-01	LABEL, WARNING GENERAL INFO.		1		
3	90267-32004	RIVET, BLIND		6		
4	90201-03008	WASHER, PLATE		6		
5	4D3-2816L-20	LABEL, WARNING AGE		1		
6	90267-32004	RIVET, BLIND		4		
7	90201-03008	WASHER, PLATE		4		
8	1C5-2816M-M0	LABEL, WARNING TIRE & LOAD		1		
9	90267-32004	RIVET, BLIND		4		
10	90201-03008	WASHER, PLATE		4		
11	1AS-2816P-00	LABEL, WARNING PASSENGER		1		
12	90267-32004	RIVET, BLIND		4		
13	90201-03008	WASHER, PLATE		4		
14	1C5-2173E-H0	GRAPHIC, 1		2		
15	4ES-2153E-30	EMBLEM, YAMAHA		2		
16	1C5-2817R-00	LABEL, LOAD LIMIT		1		
17	1C5-2817R-10	LABEL, LOAD LIMIT		1		

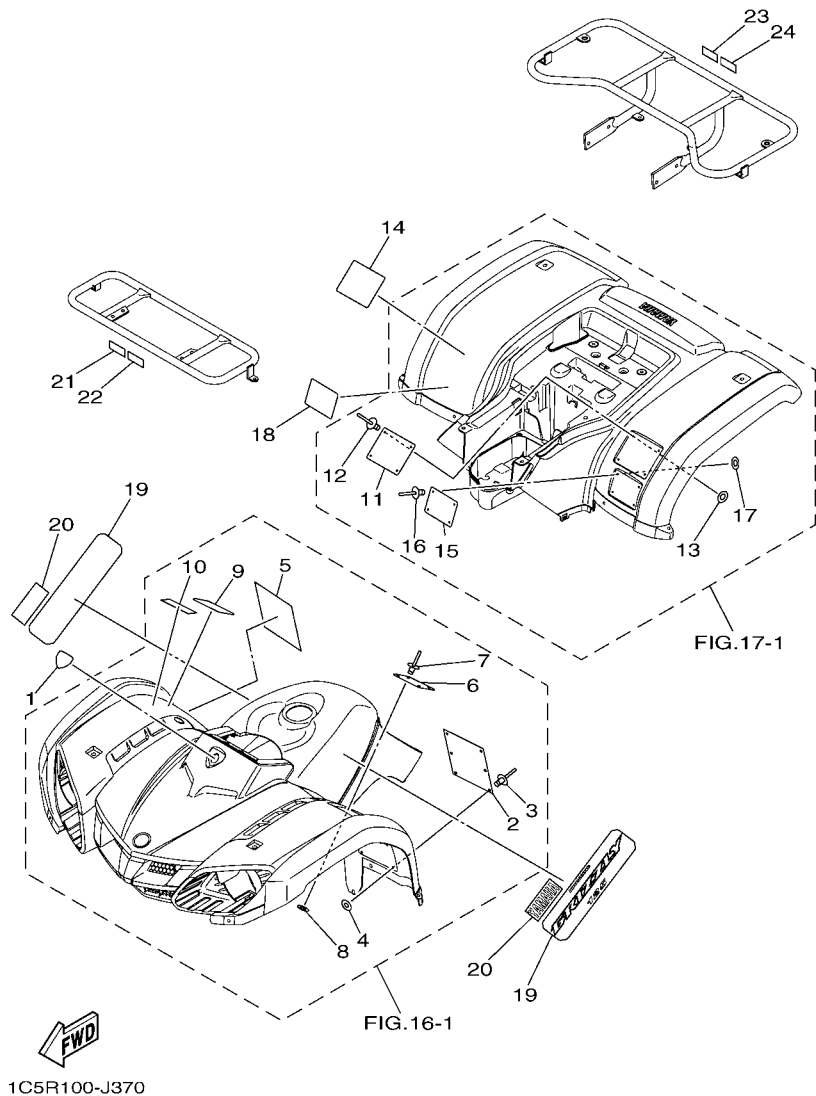

FIG. 37 EMBLEM & LABEL 3

REF. NO.	PART NO.	DESCRIPTION	CAN	EUR	JPN	REMARKS
1	3B4-26232-01	EMBLEM 3D			1	
2	5FE-21568-11	LABEL, WARNING			1	ENGLISH
3	90267-32004	RIVET, BLIND			6	
4	90201-03008	WASHER, PLATE			6	
5	4SH-21568-00	LABEL, WARNING			1	JAPANESE
6	4D3-2816L-00	LABEL, WARNING AGE			1	ENGLISH
7	90267-32004	RIVET, BLIND			4	
8	90201-03008	WASHER, PLATE			4	
9	4SH-21697-00	LABEL, CAUTION 2			1	JAPANESE
10	5YT-2151E-50	LABEL 2			1	JAPANESE
11	1C5-2816M-00	LABEL, WARNING TIRE & LOAD			1	ENGLISH
12	90267-32004	RIVET, BLIND			4	
13	90201-03008	WASHER, PLATE			4	
14	1C5-2816M-20	LABEL, WARNING TIRE & LOAD			1	
15	5FE-2151H-01	LABEL 5			1	ENGLISH
16	90267-32004	RIVET, BLIND			4	
17	90201-03008	WASHER, PLATE			4	
18	4LB-2151H-02	LABEL 5			1	JAPANESE
19	1C5-2173E-H0	GRAPHIC, 1			2	
20	4ES-2153E-30	EMBLEM, YAMAHA			2	
21	28P-2816K-20	LABEL, WARNING CARRIER 2			1	JAPANESE
22	3AC-24877-C0	LABEL, CAUTION			1	JAPANESE
23	28P-2816K-20	LABEL, WARNING CARRIER 2			1	JAPANESE
24	4AS-24877-D0	LABEL, CAUTION			1	JAPANESE

NUMERICAL INDEX

PART NO.	REF. NO.	PART NO.	REF. NO.	PART NO.	REF. NO.	PART NO.	REF. NO.	PART NO.	REF. NO.	PART NO.	REF. NO.
3FA-11102-04	1 - 1	3KW-14105-00	7 - 25	50M-15418-00	9 - 14	1HX-18535-00	14 - 7	1UY-23812-00	19 - 6	3FA-25311-00	24 - 7
4GL-1111F-00	4 - 14	10X-14106-00	7 - 4	3FA-15451-11	10 - 2	3FA-18540-00	14 - 1	1C5-23813-20	19 - 1	3FA-25317-00	24 - 10
22F-11134-10	1 - 3	5VJ-1410A-00	7 - 8	3FA-15461-10	9 - 26	1C5-21110-20	15 - 1	8K1-23814-00	19 - 4	3FA-2531E-00	24 - 29
3FA-11145-00	4 - 4	3FA-14112-25	7 - 7	3FA-15462-10	9 - 13	1C5-21110-30	15 - 1	3FA-23831-10	19 - 15	3FA-25336-00	24 - 32
3FA-11160-00	1 - 5	4U5-14126-00	7 - 6	3FA-15467-00	10 - 3	3FA-2115K-10	15 - 15		19 - 20	23F-2533A-00	24 - 17
3FA-11166-00	1 - 6	21V-14131-00	7 - 2	3FA-15471-00	10 - 11	3FA-21315-00	15 - 13	1UY-23841-01	19 - 16	3FA-25343-00	24 - 26
59V-11167-00	9 - 2	1NT-14142-12	7 - 24	3FA-15472-00	10 - 12	5YT-2151E-30	35 - 10		19 - 21	55X-25351-00	24 - 13
50M-11181-00	1 - 15	18M-14144-09	7 - 9	3FA-15475-00	10 - 15	5YT-2151E-40	35 - 11	1UY-23845-01	19 - 18	5G3-25351-02	23 - 17
22F-11186-10	1 - 10	21V-14146-00	7 - 13	3FA-15477-00	10 - 17	5YT-2151E-50	37 - 10		19 - 23		23 - 27
214-11198-01	9 - 20	24W-14147-00	7 - 29	50M-15512-00	11 - 1	5FE-2151H-01	35 - 18	3FA-23868-30	19 - 8	5V6-25367-00	24 - 23
3FA-11310-00	1 - 19	3FA-14148-00	7 - 18	3FA-15521-00	11 - 3		37 - 15	1UY-23894-01	19 - 10	3FA-25381-10	24 - 25
3FA-11351-10	1 - 20	21V-1414M-31	7 - 15	50M-15524-00	11 - 6	4LB-2151H-02	37 - 18	1C5-24110-00	21 - 1	1C5-25383-00	24 - 1
3FA-11400-00	2 - 1	5V7-14153-00	7 - 30	50M-15570-02	11 - 9	4WU-2151H-10	35 - 21	1C5-24110-10	21 - 1	3FA-25386-00	24 - 21
3FA-11500-00	2 - 7	3X3-14169-00	7 - 5	3FA-15724-00	28 - 1	4ES-2153E-30	35 - 23	1C5-2414H-00	21 - 18	1UY-25388-00	24 - 50
2HX-11610-00	2 - 6	24W-14184-00	7 - 14	3FA-15787-00	9 - 25		36 - 15	4SH-2416E-00	35 - 24	3FA-25390-00-98	24 - 3
2HX-11610-20	2 - 6	21V-14185-00	7 - 19	3FA-16111-00	12 - 1		37 - 20	55W-24500-10	21 - 10	10V-25412-00	24 - 20
2HX-11610-40	2 - 6	127-14186-00	7 - 20	3FA-16151-00	13 - 2	4SH-21568-00	37 - 5	4X8-24512-10	21 - 13	390-25412-01	24 - 30
3FA-11631-00-A0	2 - 3	5HH-14190-18	7 - 21	1C5-16611-01	12 - 10	5FE-21568-01	35 - 2	3AC-24523-00	21 - 14	3FA-25432-20	24 - 19
22K-11633-01	2 - 4	12R-14191-00	7 - 23	3FA-16620-00	12 - 7	4WU-21568-10	35 - 5	3AJ-24534-10	21 - 11	55X-25715-00	24 - 35
3FA-11636-00	2 - 3	24W-14193-00	7 - 33	14T-16626-00	12 - 8	5FE-21568-11	37 - 2	2FJ-24610-10	21 - 2	3FA-26111-20	25 - 1
3FA-11638-00	2 - 3	29U-14197-00	7 - 28	3FA-17270-00	13 - 5	1UY-21639-00	17 - 4	1C5-24710-10	22 - 1	1C5-26124-00	25 - 3
5AP-12111-01	3 - 1	3FA-14197-00	7 - 22	3FA-17285-00	13 - 9	4SH-21697-00	37 - 9	1C5-24731-00	22 - 2	1NV-26129-00	25 - 20
3FA-12113-00	3 - 5	620-1423A-66	7 - 16	3FA-17411-00	13 - 1	1C5-2171A-10	16 - 19	4K0-24774-01	22 - 8	3B4-26232-01	35 - 1
22F-12116-00	3 - 4	3FA-14412-01	6 - 5	3FA-17421-00	13 - 12	1C5-2173E-H0	35 - 22	4K0-24775-00	22 - 7		36 - 1
22F-12117-02	3 - 7	2NL-14419-00	6 - 21	3FA-17430-00	13 - 26		36 - 14	29U-24776-00	22 - 6		37 - 1
22F-12118-01	3 - 6	3FA-14422-10	16 - 13	3FA-17471-01	13 - 20		37 - 19	1C5-24841-00	27 - 6	3GB-26241-00	25 - 2
2HX-12119-00	3 - 3	3FA-14424-00	6 - 8	3FA-17519-10	13 - 17	5KM-2175B-00	16 - 17	1C5-24842-00	27 - 7	4KB-26250-11	25 - 10
5HP-12121-00	3 - 2	3FA-14437-00	6 - 17	3FA-17551-00	13 - 16	3FA-22110-00-33	18 - 1	1C5-24842-10	27 - 7	1NV-2625G-01	25 - 12
50M-12151-00	3 - 8	2XJ-14451-00	6 - 13	3FA-17611-01	12 - 27	3FA-22126-00	18 - 9	3MX-24875-A0	35 - 25	4KB-2628F-10	25 - 11
22F-12156-00	3 - 11	36F-14452-00	6 - 6	3FA-17620-01	12 - 15	1W1-22128-00	18 - 18		35 - 29	4KB-2628G-00	25 - 19
22F-12159-00	3 - 9	3FA-14453-00	6 - 19	50W-17623-00	12 - 18	401-22128-01	18 - 7		35 - 26	1NV-26304-00	25 - 18
50M-12170-01	4 - 1	59V-14457-00	6 - 9	50M-17630-00	12 - 21	2JX-22141-00	18 - 4		35 - 30	3FA-26311-10	25 - 4
50M-12176-00	4 - 2	2XJ-14458-00	6 - 14	50M-17632-00	12 - 17	2A6-22151-00	18 - 10	1C5-24877-A0	35 - 31	52H-2631G-00	25 - 28
50M-12210-00	4 - 10	3FA-14461-00	16 - 14	50M-1763E-01	12 - 24	2A6-22152-00	18 - 11	3LD-24877-A0	35 - 27	3FA-26331-01	25 - 35
4RF-12213-00	4 - 11	3FA-14472-00	6 - 7	3FA-17641-00	12 - 26	10V-22178-00	15 - 5	1C5-24877-B1	35 - 32	52H-26347-01	25 - 27
50M-12231-00	4 - 8	583-14561-00	7 - 17	4CW-17653-00	12 - 19	4V4-22184-00	15 - 6	3LD-24877-B1	35 - 28	3FA-26351-03	25 - 5
50M-12241-00	4 - 9	3DM-14613-00	8 - 9	3FA-17660-02	12 - 30	3FA-2219X-00	18 - 12	3AC-24877-C0	37 - 22	3FA-26361-10	25 - 33
3FA-13300-00	5 - 1	3FA-14628-00	8 - 1	50W-17664-00	12 - 34	3FA-22210-00-33	18 - 14	4AS-24877-D0	37 - 24	52H-26371-00	25 - 26
3FA-13325-00	5 - 2	3FA-14711-00	8 - 2	3FA-17670-00	12 - 31	3FA-23350-00-33	20 - 22	1C5-25111-00	23 - 1	3FA-26373-00	25 - 25
22F-13329-01	5 - 4	55X-14752-00	8 - 3	50W-17674-00	12 - 35	1C5-23391-00	16 - 5	3FA-25117-00	23 - 3	1C5-26393-00	25 - 36
3FA-13405-00	5 - 11	4BD-14766-00	8 - 7	3FA-17684-00	12 - 37	2HR-23442-00	19 - 3	3FA-25121-00	23 - 14	1NV-26398-00	25 - 21
51Y-13411-00	5 - 7	3FA-1490J-10	7 - 3	3FA-18101-01	14 - 8	3GB-23448-00	20 - 7	52H-2513A-00	23 - 21	3FA-26466-00	32 - 11
3Y1-13416-01	5 - 6	59V-14962-00	7 - 32	3FA-18128-00	14 - 21	3FA-23511-01	20 - 1		23 - 31	371-27114-00	22 - 3
3FA-13586-00	6 - 1	3FA-15100-00	9 - 1	3FA-18152-00	14 - 11	2NL-23517-00	20 - 8	2N3-25155-00	24 - 14	3FA-27411-10	26 - 2
5VJ-14101-10	7 - 1	30X-15351-00	5 - 9	3FA-18164-00	14 - 12	5YT-23517-00	20 - 17	3FA-25155-00	23 - 18	5GH-2741A-10	26 - 9
5VJ-14101-20	7 - 1	3FA-15362-00	10 - 9	3FA-18174-00	14 - 17	3FA-23521-01	20 - 4	3FA-25156-00	23 - 28	1C5-27453-00	26 - 4
18G-14103-00	7 - 10	50M-15381-00	12 - 13	3FA-18191-00	14 - 23	3FA-23570-00-33	20 - 13	3FA-25169-00	23 - 24	1C5-27463-00	26 - 5
21V-14105-00	7 - 25	3FA-15411-00	10 - 1	4GB-18512-00	14 - 6	3FA-23580-00-33	20 - 14	3FA-25180-00-98	23 - 6	3GB-28100-00	15 - 17

NUMERICAL INDEX

PART NO.	REF. NO.	PART NO.	REF. NO.	PART NO.	REF. NO.	PART NO.	REF. NO.	PART NO.	REF. NO.	PART NO.	REF. NO.
1NV-2811A-01	15 - 18	1C5-82590-10	33 - 27	90101-08055	4 - 6	90170-36279	12 - 9	90201-08087	9 - 12	90381-15040	15 - 10
28P-2816K-20	37 - 21	3FA-82627-00	33 - 11	90101-08056	24 - 45	90171-10001	19 - 25	90201-08609	1 - 12	90381-15088	20 - 15
	37 - 23	3FA-82910-30	32 - 1	90101-08647	24 - 51	90171-10003	20 - 11	90201-10036	19 - 12	90381-17067	20 - 2
4D3-2816L-00	35 - 6	3FA-82911-20	32 - 2	90105-08181	1 - 13	90171-14002	23 - 12	90201-10052	24 - 44		20 - 5
	37 - 6	1S3-82913-00	25 - 22	90105-10131	18 - 15	90171-14004	24 - 48	90201-10057	20 - 10	90386-18028	18 - 8
4D3-2816L-10	35 - 9	5LP-82913-11	32 - 24	90105-10183	15 - 2	90175-06013	25 - 6	90201-10061	11 - 5	90387-06153	16 - 4
4D3-2816L-20	36 - 5	3JN-82921-10	32 - 15	90105-10233	20 - 20	90179-06055	27 - 2	90201-12030	28 - 5	90387-06201	31 - 6
1C5-2816M-00	35 - 14	50M-83371-20	33 - 38	90105-10262	20 - 23	90179-08030	32 - 13	90201-12045	18 - 5	90387-065L7	31 - 12
	37 - 11	5GH-83516-00	33 - 37	90105-10274	20 - 9		32 - 20	90201-12047	18 - 19	90387-066H4	21 - 9
1C5-2816M-10	35 - 17	5TE-83530-00	33 - 36	90105-10277	15 - 3	90179-10022	23 - 7	90201-12048	24 - 43	90387-07598	21 - 5
1C5-2816M-20	37 - 14	2HT-83912-00	32 - 3	90105-10280	24 - 41		24 - 6	90201-13409	15 - 7	90387-090R0	19 - 11
1C5-2816M-M0	36 - 8	59V-83922-00	32 - 16	90105-12060	24 - 40	90179-14469	12 - 11	90201-14021	24 - 47	90387-101R3	20 - 16
1AS-2816P-00	36 - 11	437-83936-01	33 - 32	90105-14003	14 - 4	90179-20255	13 - 25	90201-14586	23 - 11	90387-113W0	24 - 42
43P-2816R-01	36 - 2	3FA-83965-10	32 - 4	90109-06172	16 - 2	90179-55464	13 - 19	90201-15700	13 - 3	90387-161V0	12 - 25
4D3-2817J-20	35 - 12	3FA-83966-00	32 - 7	90109-06189	14 - 25	90183-05008	30 - 8	90201-163F8	11 - 10	90387-167L5	4 - 3
4D3-2817J-30	35 - 13	3FA-83967-00	32 - 6	90109-06214	26 - 10	90183-06053	16 - 11	90201-221M8	13 - 8	90387-175R2	23 - 10
1C5-2817R-00	36 - 16	4KB-83973-21	32 - 14	90109-06723	33 - 6		16 - 20	90201-252A4	13 - 13	90387-251W4	13 - 21
1C5-2817R-10	36 - 17	1C5-83976-00	32 - 25	90109-06798	32 - 5		26 - 1	90202-08175	25 - 8	90430-06014	4 - 13
1C5-28309-00	16 - 7	3FA-83980-03	32 - 8		32 - 17	90183-060A7	16 - 9	90202-14077	31 - 5	90430-10148	33 - 10
5GH-28349-00	16 - 12	3FA-83980-10	32 - 23	90109-08705	15 - 8	90185-08016	15 - 9	90206-06090	8 - 8	90430-14043	9 - 22
5GT-2836B-10	16 - 18	4KB-84314-01	30 - 1	90114-10014	23 - 2	90185-10019	19 - 13	90209-06096	6 - 15	90430-14194	14 - 5
1C5-2845N-00	27 - 4	5KM-84320-01	30 - 2		24 - 2	90185-10022	15 - 4	90214-04038	12 - 23	90445-072A4	33 - 7
1C5-2845N-10	27 - 4	2GU-84332-00	30 - 5	90116-06541	1 - 2		18 - 16	90215-14236	12 - 28	90445-09304	21 - 3
1C5-81410-00	28 - 3	2GU-84334-00	30 - 6	90116-08084	24 - 28		20 - 21	90215-21239	13 - 24	90445-10043	21 - 16
1C5-81450-01	28 - 2	5EH-84340-00	30 - 3	90116-10042	24 - 24		20 - 24	90215-22276	13 - 6	90445-10456	21 - 16
3FA-81800-01	29 - 1	3FA-84702-10	31 - 10	90119-05021	26 - 13	90185-12007	18 - 6	90240-12092	18 - 17	90445-121F6	9 - 4
50M-81801-M0	29 - 2	3FA-84702-20	31 - 10	90119-06147	16 - 3	90201-03008	35 - 4	90249-12008	25 - 9	90450-45075	6 - 12
3FA-81828-00	29 - 5	3FA-84702-30	31 - 10	90119-06152	17 - 2		35 - 8	90267-32004	35 - 3		6 - 20
3FA-8183G-00	29 - 6	5KM-84703-10	30 - 7		27 - 3		35 - 16		35 - 7	90450-54008	10 - 16
3MW-81940-01	33 - 17	3FA-84710-00	31 - 1	90119-06201	16 - 8		35 - 20		35 - 15	90460-58015	6 - 18
2NL-81950-92	33 - 20	1A2-84714-41	31 - 2	90123-08002	32 - 12		36 - 4		35 - 19	90464-12045	33 - 30
29U-81950-93	33 - 19	2EK-85111-00	34 - 1		32 - 19		36 - 7		36 - 3	90464-13073	33 - 28
5GT-81960-00	33 - 14	3Y6-85130-02	34 - 7	90149-04278	25 - 13		36 - 10		36 - 6	90464-15195	31 - 3
3FA-82110-12	33 - 21	449-85131-02	34 - 4	90149-05024	33 - 12		36 - 13		36 - 9		33 - 29
3FA-82115-01	33 - 22	3FA-85540-20	33 - 1	90149-06108	21 - 15		37 - 4		36 - 12	90464-35132	33 - 40
3FA-82116-00	33 - 23	5HP-85546-00	33 - 2	90150-06016	16 - 10		37 - 8		37 - 3	90465-08125	9 - 30
29W-82123-00	17 - 3	1C5-W215B-12	16 - 1		16 - 21		37 - 13		37 - 7	90465-08127	9 - 10
133-82131-00	33 - 24	1C5-W215C-12	16 - 1	90154-05021	30 - 9		37 - 17		37 - 12	90465-10098	33 - 31
1UY-82150-00	33 - 25	1C5-W215D-10	16 - 1	90155-06001	5 - 5	90201-06032	26 - 7		37 - 16	90467-09006	21 - 17
1UY-82151-00	33 - 26	1C5-W216B-11	17 - 1	90159-05044	30 - 10	90201-06033	26 - 11	90269-05055	14 - 18	90467-13064	1 - 7
4KJ-82310-10	33 - 3	1C5-W216C-11	17 - 1	90159-05045	6 - 11		31 - 13	90269-07076	16 - 6		9 - 5
1UY-82370-20	33 - 8	1C5-W216D-10	17 - 1	90170-05302	3 - 10	90201-06090	21 - 6	90280-03047	2 - 2	90467-220A1	6 - 10
5LP-82510-00	33 - 33	4BE-W2536-00	23 - 15	90170-10010	19 - 19	90201-06097	31 - 7	90336-22056	19 - 2	90480-01400	21 - 4
4KM-82540-00	33 - 9		23 - 25		19 - 24	90201-06412	12 - 5	90338-23172	27 - 9	90480-13018	9 - 24
3FA-82541-00	33 - 13	3FA-W253A-00	24 - 11	90170-10011	24 - 22	90201-06630	10 - 8	90340-14036	9 - 23	90480-14088	31 - 4
3HN-82569-00	33 - 34	90101-06046	23 - 19	90170-12011	12 - 29	90201-08043	27 - 11	90340-14117	9 - 31	90480-14555	31 - 11
3HN-82579-00	33 - 35		23 - 29	90170-12181	28 - 6	90201-08048	4 - 5	90340-14132	9 - 21	90480-18290	21 - 8
1C5-82590-00	33 - 27		24 - 15	90170-33011	24 - 27		8 - 12	90340-36078	9 - 33	90501-08511	25 - 34

NUMERICAL INDEX

PART NO.	REF. NO.	PART NO.	REF. NO.	PART NO.	REF. NO.	PART NO.	REF. NO.	PART NO.	REF. NO.	PART NO.	REF. NO.
90501-10353	14 - 3	92902-06200	20 - 19	93306-20301	13 - 27	95802-06010	27 - 8	98702-06016	9 - 18		
90501-122E1	25 - 7	92902-06600	8 - 5	93306-20336	2 - 9	95802-06012	15 - 16	98902-06010	8 - 6		
90501-18576	5 - 8		14 - 22	93306-20401	13 - 11	95802-06025	31 - 14	98902-06020	26 - 6		
90501-505F1	12 - 36		24 - 37	93306-20532	13 - 15	95812-06012	33 - 39	98980-04012	12 - 22		
90506-15260	23 - 16		29 - 9	93306-30201	13 - 28	95812-08014	26 - 3	99001-04600	22 - 10		
	23 - 26		33 - 16	93311-43048	13 - 14	95812-08016	8 - 11	99001-05600	5 - 3		
	24 - 12	92902-08600	14 - 15	93315-11040	11 - 2		15 - 14	99001-09600	11 - 4		
90508-12761	14 - 24	92990-10600	19 - 26	93399-99918	12 - 12		27 - 5	99001-10600	5 - 12		
90508-20779	22 - 9	93101-21170	12 - 16	93410-22039	13 - 7		27 - 10	99001-12600	14 - 9		
90508-29760	14 - 13	93102-14209	14 - 10	93440-10109	1 - 4	95822-06010	25 - 37	99009-22400	12 - 2		
90560-15348	13 - 4	93102-22294	9 - 15	93450-14088	2 - 5	95822-06025	14 - 19	99009-35700	11 - 8		
90793-26276	33 - 21	93102-22335	12 - 4	93503-08007	14 - 2	95822-06035	21 - 7	99530-10114	1 - 16		
91312-06012	4 - 15	93102-23275	23 - 5	93605-18078	9 - 16	95822-08016	18 - 13		1 - 17		
91312-06016	4 - 12	93102-30243	13 - 22	93700-06004	15 - 12	95822-08050	19 - 5		9 - 27		
	14 - 20	93102-35349	24 - 39		18 - 2	97002-06012	22 - 4		10 - 4		
91312-06020	6 - 3	93102-40367	23 - 23		20 - 3	97002-06020	33 - 4	99530-12016	9 - 3		
	13 - 18		23 - 33		20 - 6		33 - 15				
91312-06110	1 - 18	93102-42260	24 - 9		20 - 18	97002-06025	29 - 7				
91401-20020	19 - 14	93104-09025	25 - 17	93834-12016	13 - 23	97022-06025	32 - 21				
	19 - 27	93104-41119	12 - 32	93900-00022	23 - 9	97022-08060	19 - 9				
	20 - 12	93112-31011	19 - 7		24 - 5	97802-03008	7 - 11				
91401-25015	14 - 16	93210-06564	9 - 19	94107-08008	23 - 8	98502-03008	25 - 29				
91401-30025	18 - 20	93210-08006	5 - 13	94110-08008	24 - 4	98502-03540	30 - 4				
	23 - 13	93210-12327	23 - 22	94580-25092	4 - 7	98502-04014	7 - 26				
91401-30030	24 - 49		23 - 32	94582-02074	24 - 53	98502-05010	24 - 33				
91701-08058	14 - 14	93210-14104	24 - 18	94701-00366	1 - 14	98502-05016	25 - 31				
91A20-07010	7 - 34	93210-14369	9 - 32	94703-00366	1 - 14	98502-05020	16 - 15				
92012-06020	28 - 4	93210-15414	15 - 11	95022-06008	33 - 18		25 - 23				
92502-06008	7 - 31	93210-19123	10 - 10	95302-05600	34 - 9	98502-06008	10 - 7				
92502-06012	24 - 36	93210-25711	29 - 4	95302-06600	23 - 20	98502-06010	8 - 4				
92902-03100	7 - 12	93210-30611	6 - 2		23 - 30		12 - 6				
92902-03600	25 - 30	93210-347A1	5 - 10		24 - 16		12 - 14				
92902-04100	7 - 27	93210-357A3	9 - 34		31 - 9	98502-06016	1 - 9				
92902-05100	34 - 3	93210-41041	15 - 19	95302-08600	24 - 31	98502-06020	32 - 9				
	34 - 6	93210-43713	12 - 33		24 - 46	98502-06030	9 - 6				
	34 - 8	93210-44704	1 - 11		24 - 52		9 - 28				
92902-05200	34 - 2	93210-53679	1 - 21	95302-10700	19 - 17		10 - 5				
	34 - 5	93210-55669	29 - 3		19 - 22		10 - 13				
92902-05600	16 - 16	93210-63556	1 - 8	95307-05700	25 - 16	98502-06040	9 - 7				
	24 - 34	93210-704A7	9 - 17	95312-06600	26 - 12		9 - 29				
	25 - 24	93210-97690	12 - 20	95602-05100	25 - 15	98502-06045	10 - 14				
	25 - 32	93211-63688	24 - 38	95602-06100	32 - 10	98502-06060	6 - 16				
92902-06100	22 - 5	93306-00307	11 - 7		32 - 18		9 - 8				
	29 - 8	93306-00308	23 - 4	95702-05300	26 - 14	98502-06070	9 - 9				
	31 - 8	93306-00433	12 - 3	95702-06300	26 - 8	98502-06090	10 - 6				
	32 - 22	93306-00710	24 - 8	95702-06500	6 - 4	98502-08012	9 - 11				
	33 - 5	93306-20201	13 - 10		8 - 10	98507-03008	21 - 12				
92902-06200	18 - 3	93306-20215	2 - 8	95802-06010	27 - 1	98507-05020	25 - 14				