



PARTS CATALOGUE

YFM250BT (1P01) U.S.A.

YFM250BT (1P02) CANADA



2007/1/15

1D1P0-100E1

(2D1P0-100E1)

NEWS NO.	DATE	COMMENT
PE0-MC-040129	Oct.,13,2004	FIG.8 CARBURETOR LIST CORRECTION
PE0-MC-060009	Feb.,10,2006	FIG.40 HEADLIGHIT ILLUSTRATION REVISION
PE0-MC-060100	Aug.,8,2006	FIG.39 ILLUSTRATION CORRECTION
PE0-MC-070006	Jan.,15,2007	FOREWORD SERIAL NO ILLUSTRATION REVISION
PE0-MC-070060	Nov.,21,2007	FIG.16 SHIFTCAM & FORK ILLUSTRATION CORRECTION

YFM250BT
PARTS CATALOGUE
©2004 by Yamaha Motor Co., Ltd.
1st edition, September 2004
All rights reserved.
Any reprinting or unauthorized use
without the written permission of
Yamaha Motor Co., Ltd.
is expressly prohibited.
Printed in Japan.

A3



A4

FOREWORD

This Parts Catalogue is related to the parts for the model(s) on the cover page. When you are ordering replacement parts, please refer to this Parts Catalogue and quote both part numbers and part names correctly.

1. Modifications or additions which have been made after the issue of the Parts Catalogue will be announced in the Parts News.

It is advisable that you make the necessary corrections to the Parts Catalogue according to the Parts News.

2. Abbreviations

The following abbreviations are used in this Parts Catalogue.

“UR” Use specified parts number.

“UN” Use as many as needed.

“AP” Alternate Parts

“LM” Locally Made (Parts need to be ordered locally)

“F#” Frame No. (Applicable machine No.)

“O/S” Over Size

3. The number of components for assembly

- Parts, which are to be supplied in an assembly, are listed with a dot (.) in front of the part name as shown below.
- The numeral appearing to the right of each component part indicates the quantity of parts for each assembly unit.

PART NO.	DESCRIPTION	Q'TY	REMARKS
2F5-83310-60	FRONT FLASHER LIGHT ASSY	2	
115-83311-60	.BULB (6V-18W)	1	

4. Applicable colours of graphics are represented in the “REMARKS” as shown below.

PART NO.	DESCRIPTION	Q'TY	REMARKS
2N4-24110-00-X5	FUEL TANK COMP.	2	MXR
3J1-24240-10	.GRAPHIC, FUEL TANK	1	FOR MXR

5. Note that the illustrations for reference in finding parts numbers are not to be used for assembling. When assembling, please use the applicable service manual.

6. The asterisk (*) before a reference number indicates modified items after the first edition.
7. A part with “YMUS” in the remarks column can be obtained from YMUS (USA) and not from YAMAHA MOTOR CO.,LTD (JAPAN).

PART NO.	DESCRIPTION	Q'TY	REMARKS
EW2-U5160-00	ENGINE HATCH COMP	2	YMUS
90601-168U7	BAND,HOSE	1	YMUS

ADDRESS:

YAMAHA MOTOR CORPORATION U.S.A.
PARTS & ACCESSORY DIV.
6555 KATELLA AVENUE
CYPRESS, CALIFORNIA 90630 U.S.A.

FOREWORD

8. Applicable Serial No.

Engine Serial No.

Frame Serial No.

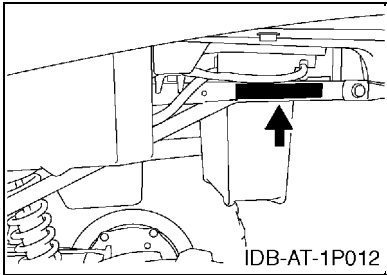
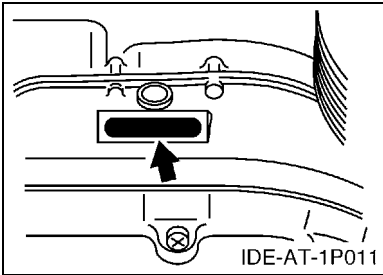

9. Applicable Colour Code (The (*) mark shows Model colour.)

Abbreviation	Colour Name	Colour Code
DPBSN(*)	DARK PURPLISH BLUE SOLID N	0891
PDG(*)	PASTEL DEEP GREEN	00K0
RTR(*)	ROMANTIQUE ROUGE	00TR

10. Quantity Column Information

Column No.	Name Of Q'ty Column	Destination
1	USA	U.S.A.
2	CAN	CANADA

MODEL LABEL

(1) A label called "Model Label" is affixed in the location as indicated in (3) below. When using this parts catalogue, please be sure to cross-reference the "model code - production code No." in the catalogue with the "model code - production code No." indicated on the Model Label affixed onto the product concerned.

(2) "Model Label" Indication

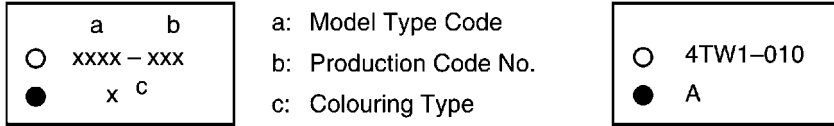

(3) Model Label Affixing Location

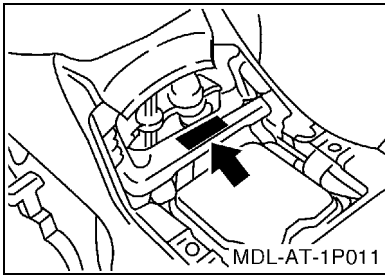

(4) Colouring Information

Model Code	Colouring Type Code	Colour Code	Colour Name	Abbreviation
1P01	A	00TR	ROMANTIQUE ROUGE	RTR
	B	00K0	PASTEL DEEP GREEN	PDG
	G	0891	DARK PURPLISH BLUE SOLID N	DPBSN
1P02	G	0891	DARK PURPLISH BLUE SOLID N	DPBSN

(5) Model Code - Production Code Number of Model Listed in This Parts Catalogue

Model Code	Production Code No.	Country (destination)	Model Code	Production Code No.	Country (destination)
1P01	010	U.S.A.			
1P02	010	CANADA			

CONTENTS

ENGINE

CYLINDER HEAD	B2
CYLINDER	B4
CRANKSHAFT & PISTON	B5
VALVE	B7
CAMSHAFT & CHAIN	B8
INTAKE	B9
OIL PUMP	B10
CARBURETOR	B11
EXHAUST	B13
CRANKCASE	B14
CRANKCASE COVER 1	B15
STARTER	C3
STARTER CLUTCH	C4
CLUTCH	C5
TRANSMISSION	C6
MIDDLE DRIVE GEAR	C7
DRIVE SELECTOR	C10
SHIFT CAM & FORK	C12
SHIFT SHAFT	C13

CHASSIS

FRAME	C14
FRONT FENDER	C15
REAR FENDER	D2
SIDE COVER	D3
REAR ARM	D4
DRIVE SHAFT	D5
REAR SUSPENSION	D8
FRONT SUSPENSION & WHEEL	D9
STEERING	D10
FUEL TANK	D11
SEAT	D12
FRONT WHEEL	D13
FRONT BRAKE CALIPER	D14
REAR WHEEL	D15
STEERING HANDLE & CABLE	E3
FRONT MASTER CYLINDER	E4
STAND & FOOTREST	E5
GUARD	E6
GENERATOR	E7
STARTING MOTOR	E8

HEADLIGHT	E9
TAILLIGHT	E10
TAILLIGHT 2	E11
HANDLE SWITCH & LEVER	E12
ELECTRICAL 1	E13
ELECTRICAL 2	E15
EMBLEM & LABEL 1	F2
EMBLEM & LABEL 2	F3

INDEX

NUMERICAL INDEX	M1
-----------------------	----

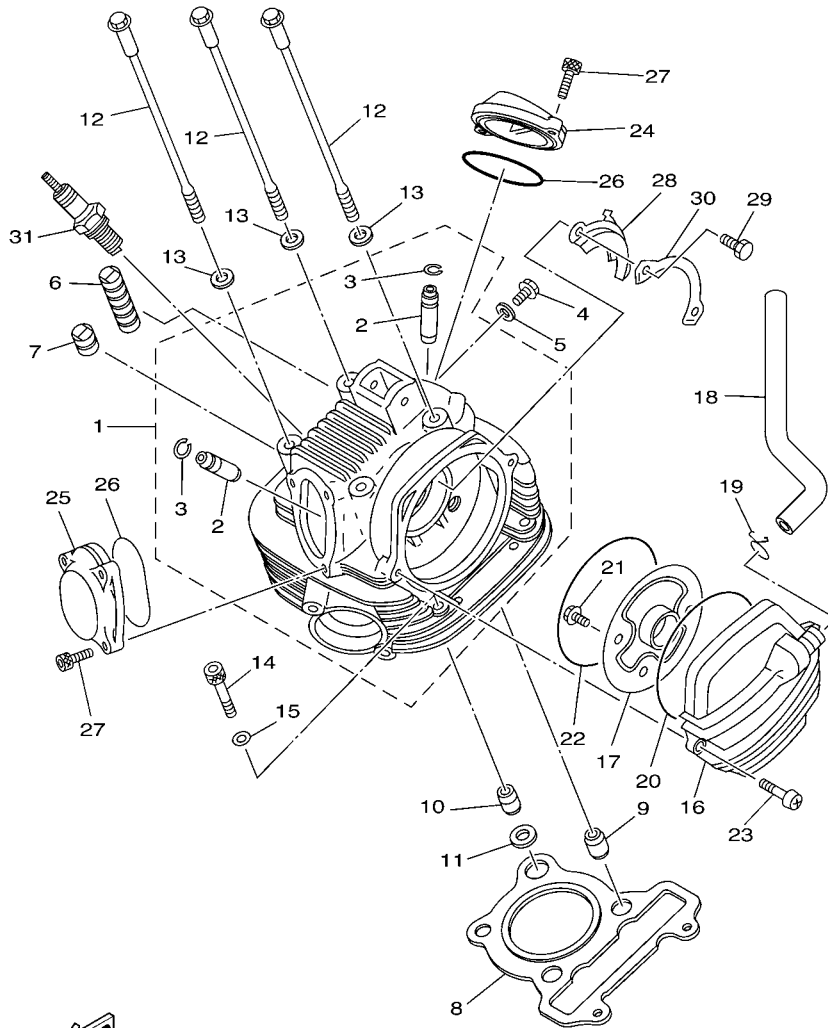

1P01100-D010

FIG. 1 CYLINDER HEAD

REF. NO.	PART NO.	DESCRIPTION	USA	CAN	REMARKS
1	5XG-E1102-00	CYLINDER HEAD ASSY	1	1	(YMUS)
2	5H0-11133-11	.GUIDE, VALVE 1	2	2	
3	93440-10085	.CIRCLIP	2	2	
4	90153-06803	SCREW, HEXAGON	1	1	(YMUS)
5	90430-06014	GASKET	1	1	
6	5XG-E1162-00	ABSORBER 2	1	1	(YMUS)
7	5XG-E1161-00	ABSORBER 1	1	1	(YMUS)
8	3GH-11181-00	GASKET, CYLINDER HEAD 1	1	1	
9	99530-14016	PIN, DOWEL	2	2	
10	93612-16254	PIN, DOWEL	1	1	
11	90430-12186	GASKET	1	1	
12	90105-08195	BOLT, FLANGE	4	4	
13	90201-088C3	WASHER, PLATE	4	4	(YMUS)
14	91317-08045	BOLT	2	2	
15	90201-087G0	WASHER, PLATE	2	2	
16	5XG-E1160-00	BREATHER ASSY	1	1	(YMUS)
17	5XG-E1165-00	PLATE, BREATHER	1	1	(YMUS)
18	4XE-11166-00	PIPE, BREATHER 1	1	1	
19	90467-14015	CLIP	1	1	
20	93210-92800	O-RING	1	1	
21	95027-06012	BOLT, FLANGE	2	2	
22	93211-058A2	O-RING	1	1	
23	98507-06020	SCREW, PAN HEAD	2	2	
24	5XG-E1186-00	COVER, CYLINDER HEAD SIDE 2	1	1	(YMUS)
25	5XG-E1187-00	COVER, CYLINDER HEAD SIDE 3	1	1	(YMUS)
26	93210-57897	O-RING	2	2	
27	91317-06018	BOLT	5	5	

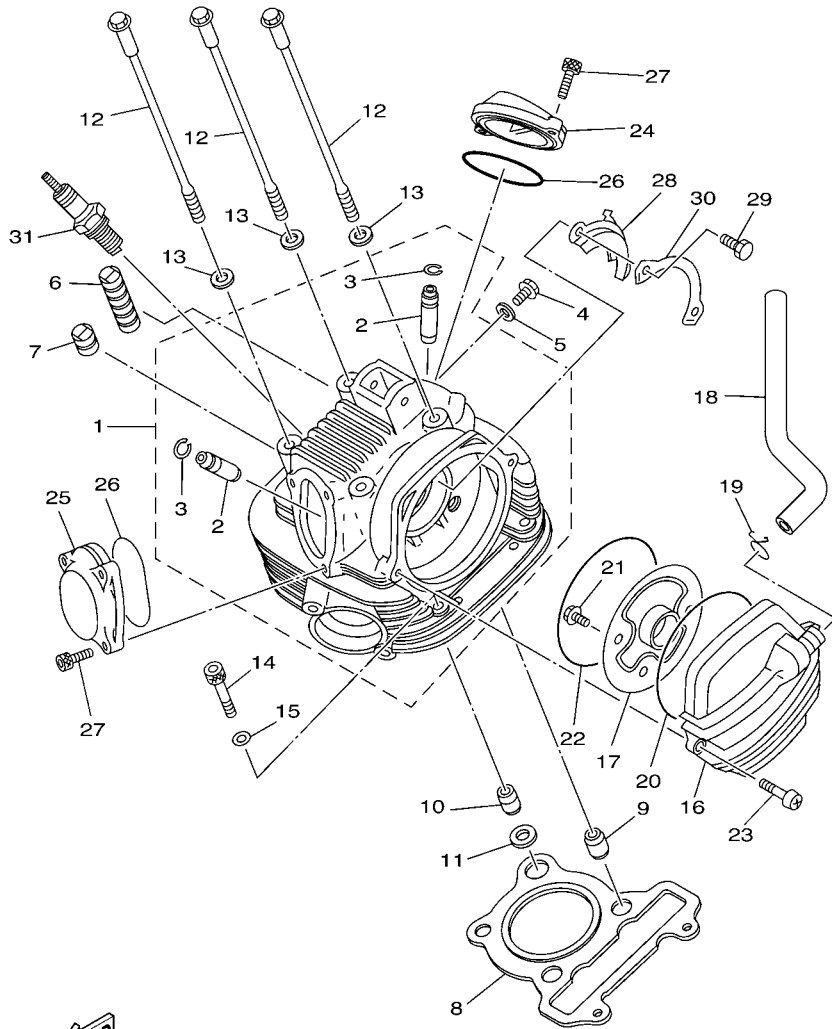



1P01100-D010

FIG. 1 CYLINDER HEAD

REF. NO.	PART NO.	DESCRIPTION	USA	CAN	REMARKS
28	3UR-E111F-00	PLATE	1	1	(YMUS)
29	97007-06012	BOLT	2	2	
30	90215-06809	WASHER, LOCK	1	1	(YMUS)
31	94700-00852	PLUG, SPARK (NGK DR7EA)	1	1	

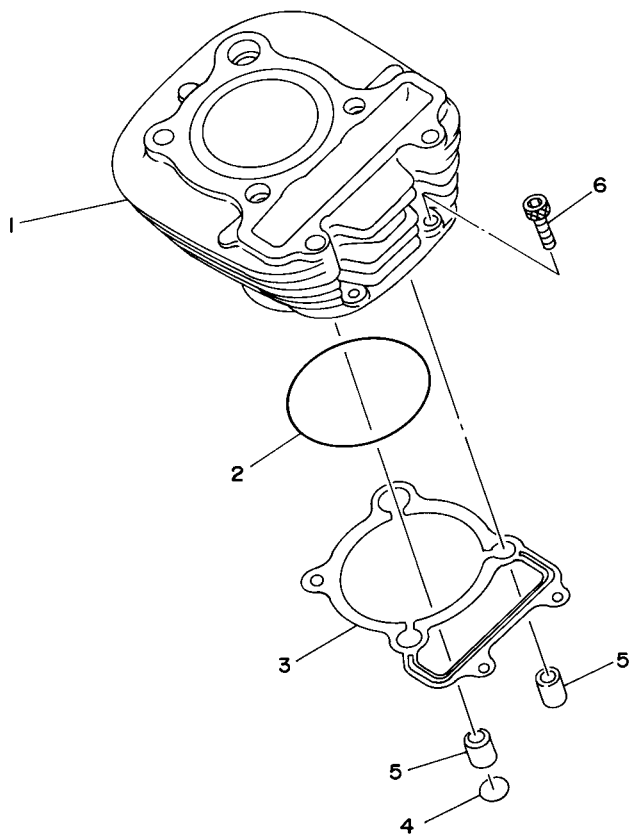
FIG. 2 CYLINDER



REF. NO.	PART NO.	DESCRIPTION	USA	CAN				REMARKS
1	5XG-E1310-00	CYLINDER	1	1				(YMUS)
2	93210-72800	O-RING	1	1				
3	5VC-11351-00	GASKET, CYLINDER	1	1				
4	93210-13361	O-RING	1	1				
5	99530-14016	PIN, DOWEL	2	2				
6	91317-06025	BOLT	2	2				

FWD
4BD1110-2020

FIG. 3 CRANKSHAFT & PISTON

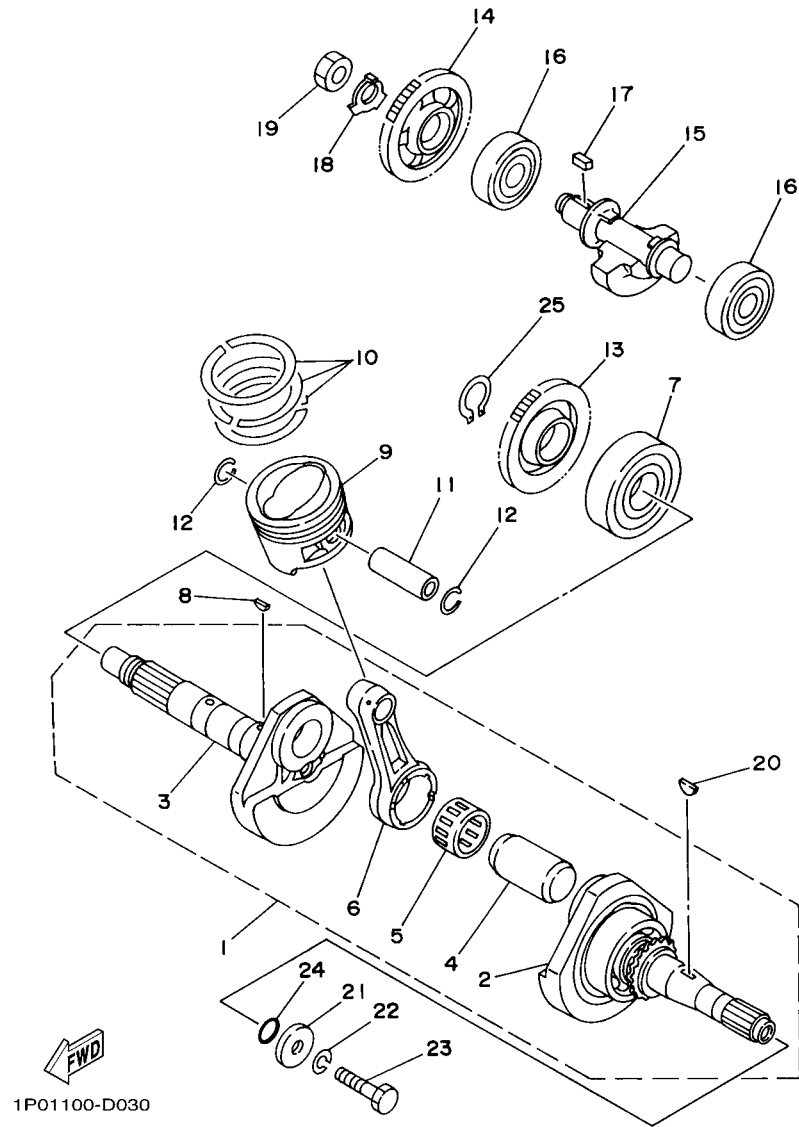

1P01100-D030

REF. NO.	PART NO.	DESCRIPTION	USA	CAN	REMARKS
1	5XG-E1400-00	CRANKSHAFT ASSY	1	1	(YMUS)
2	5XG-WE141-00	.CRANK 1	1	1	(YMUS)
3	5XG-E1422-00	.CRANK 2	1	1	(YMUS)
4	3UR-E1681-00	.PIN, CRANK 1	1	1	(YMUS)
5	93310-530J3	.BEARING	1	1	
6	5XG-E1651-00	.ROD, CONNECTING	1	1	(YMUS)
7	93306-30611	BEARING	1	1	
8	90280-03017	KEY, WOODRUFF	1	1	
9	4BD-11631-00-Y0	PISTON (STD)	1	1	
	4BD-11636-00	PISTON (0.50MM O/S)	1	1	AP
	4BD-11638-00	PISTON (1.00MM O/S)	1	1	AP
10	5XG-E1603-00	PISTON RING SET (STD)	1	1	(YMUS)
	5XG-E1605-00	PISTON RING SET (0.50MM O/S)	1	1	AP (YMUS)
	5XG-E1607-00	PISTON RING SET (1.00MM O/S)	1	1	AP (YMUS)
11	5XG-E1633-00	PIN, PISTON	1	1	(YMUS)
12	93450-17044	CIRCLIP	2	2	
13	5XG-E1536-00	GEAR, DRIVE	1	1	(YMUS)
14	5XG-E1531-00	GEAR, BALANCE WEIGHT	1	1	(YMUS)
15	5XG-E1454-00	WEIGHT 1	1	1	(YMUS)
16	93306-30427	BEARING	2	2	
17	90282-05013	KEY, STRAIGHT	1	1	
18	90215-14810	WASHER, LOCK	1	1	(YMUS)
19	90170-14839	NUT	1	1	(YMUS)
20	90280-05048	KEY, WOODRUFF	1	1	
21	90201-107F8	WASHER, PLATE	1	1	
22	92907-10100	WASHER, SPRING	1	1	
23	90101-10568	BOLT	1	1	

FIG. 3 CRANKSHAFT & PISTON

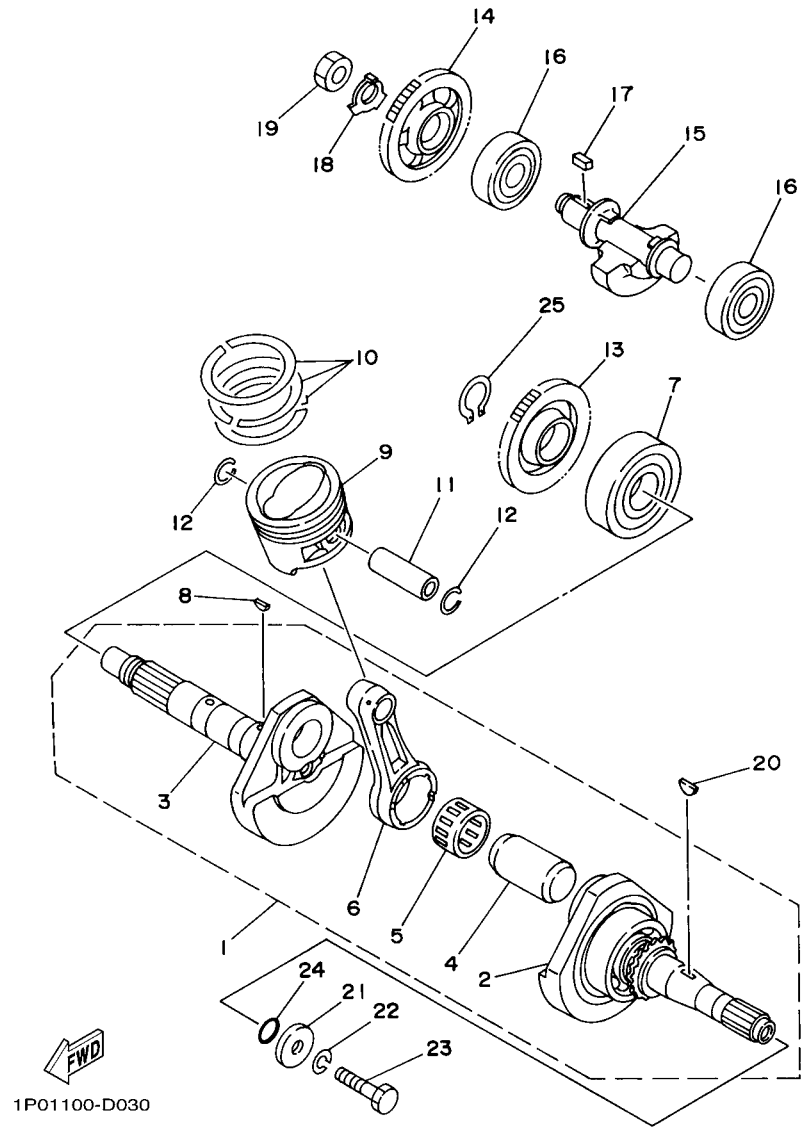

REF. NO.	PART NO.	DESCRIPTION	USA	CAN	REMARKS
24	93210-16800	O-RING	1	1	
25	99009-26400	CIRCLIP	1	1	

FIG. 4 VALVE

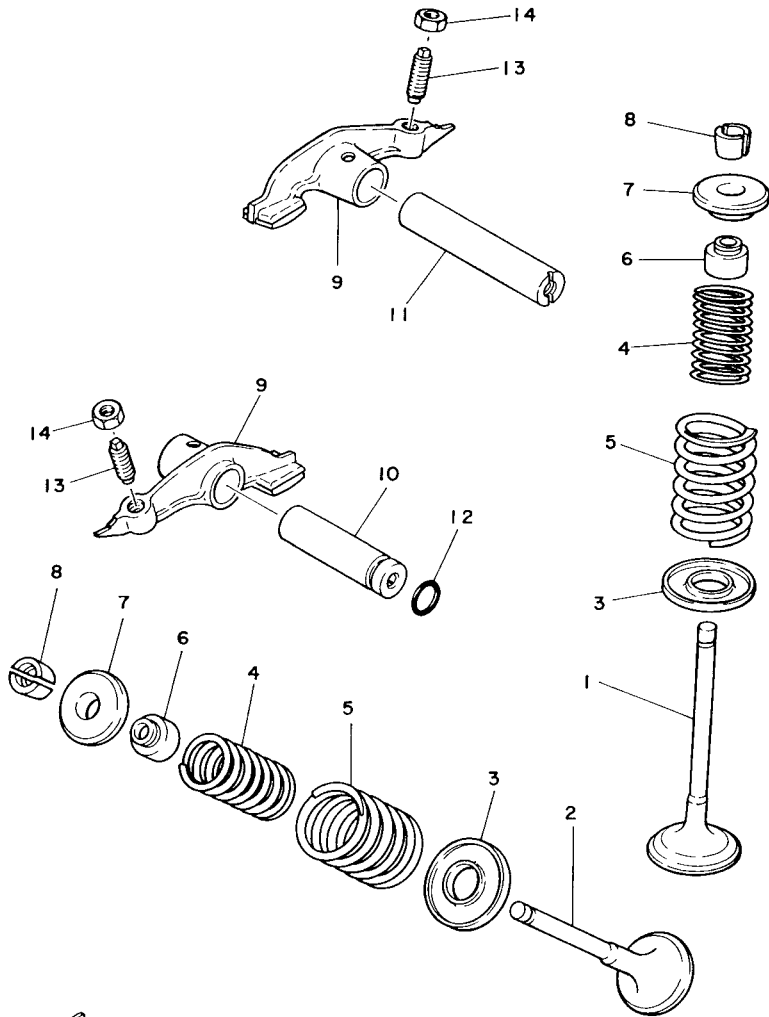

REF. NO.	PART NO.	DESCRIPTION	USA	CAN	REMARKS
1	5XG-E2111-00	VALVE, INTAKE	1	1	(YMUS)
2	5XG-E2121-00	VALVE, EXHAUST	1	1	(YMUS)
3	4G0-12116-01	SEAT, VALVE SPRING	2	2	
4	4G0-12113-01	SPRING, VALVE INNER	2	2	YELLOW
5	4G0-12114-01	SPRING, VALVE OUTER	2	2	YELLOW
6	5H0-12119-00	SEAL, VALVE STEM	2	2	
7	4G0-12117-00	RETAINER, VALVE SPRING	2	2	
8	4G0-12118-00	COTTER, VALVE	4	4	
9	5XG-E2151-00	ARM, VALVE ROCKER	2	2	(YMUS)
10	3UR-E2156-00	SHAFT, ROCKER 2	1	1	(YMUS)
11	3UR-E2146-00	SHAFT, ROCKER	1	1	(YMUS)
12	93210-09165	O-RING	1	1	
13	2NX-12159-00	SCREW, VALVE ADJUSTING	2	2	
14	90170-06128	NUT	2	2	



29U110-5040

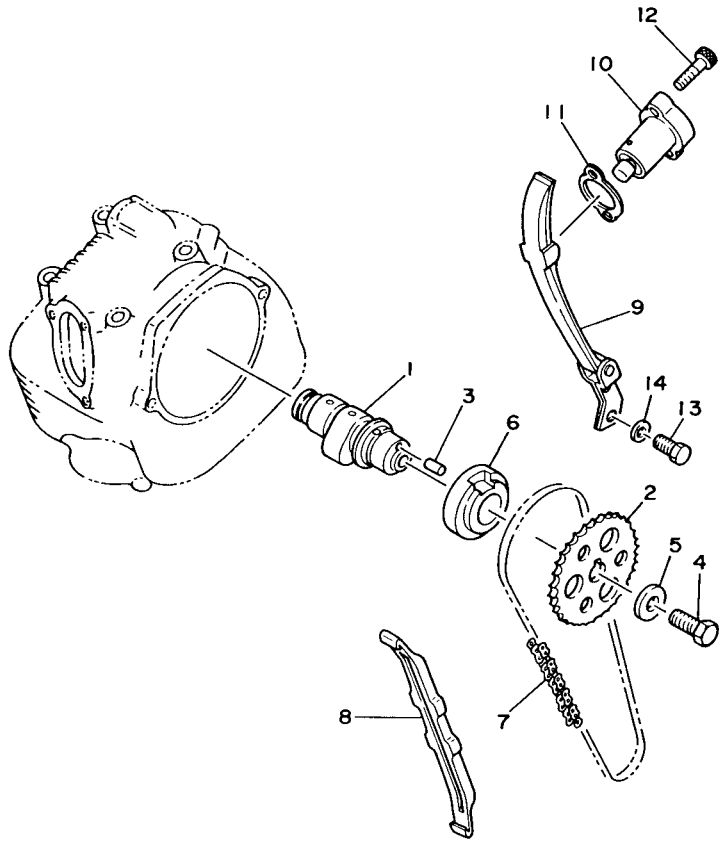

FIG. 5 CAMSHAFT & CHAIN

REF. NO.	PART NO.	DESCRIPTION	USA	CAN	REMARKS
1	5XG-E2171-00	CAMSHAFT 1	1	1	(YMUS)
2	5XG-E2176-00	SPROCKET, CAM CHAIN	1	1	(YMUS)
3	93604-10837	PIN, DOWEL	1	1	
4	90101-10303	BOLT	1	1	
5	90201-108C6	WASHER, PLATE	1	1	(YMUS)
6	90389-25800	BUSH	1	1	(YMUS)
7	94580-41104	CHAIN (DID25SH 104L)	1	1	
8	3UR-E2231-00	GUIDE, STOPPER 1	1	1	(YMUS)
9	5XG-E2241-00	GUIDE, STOPPER 2	1	1	(YMUS)
10	3GC-12210-10	TENSIONER ASSY, CAM CHAIN	1	1	
11	4FM-12213-00	GASKET, TENSIONER CASE	1	1	
12	95027-06025	BOLT, FLANGE	2	2	
13	97027-06016	BOLT	2	2	
14	92907-06600	WASHER, PLATE	2	2	



29U110-5050

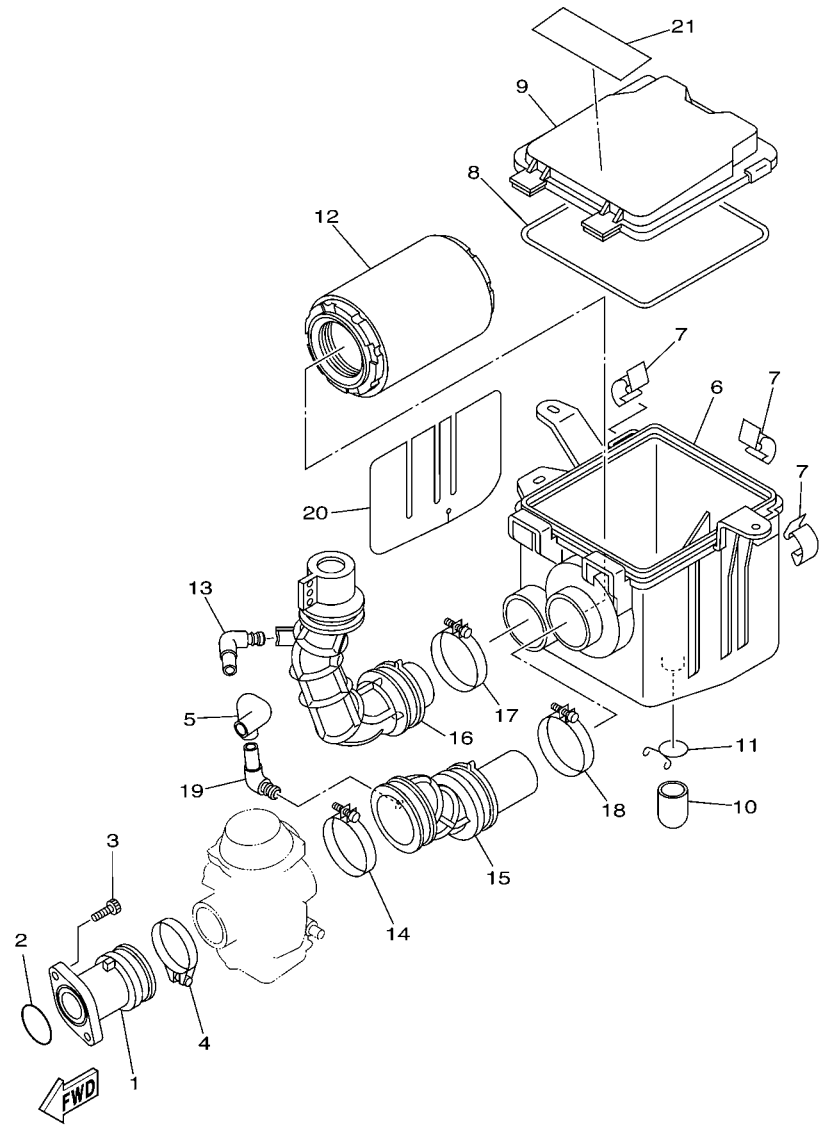
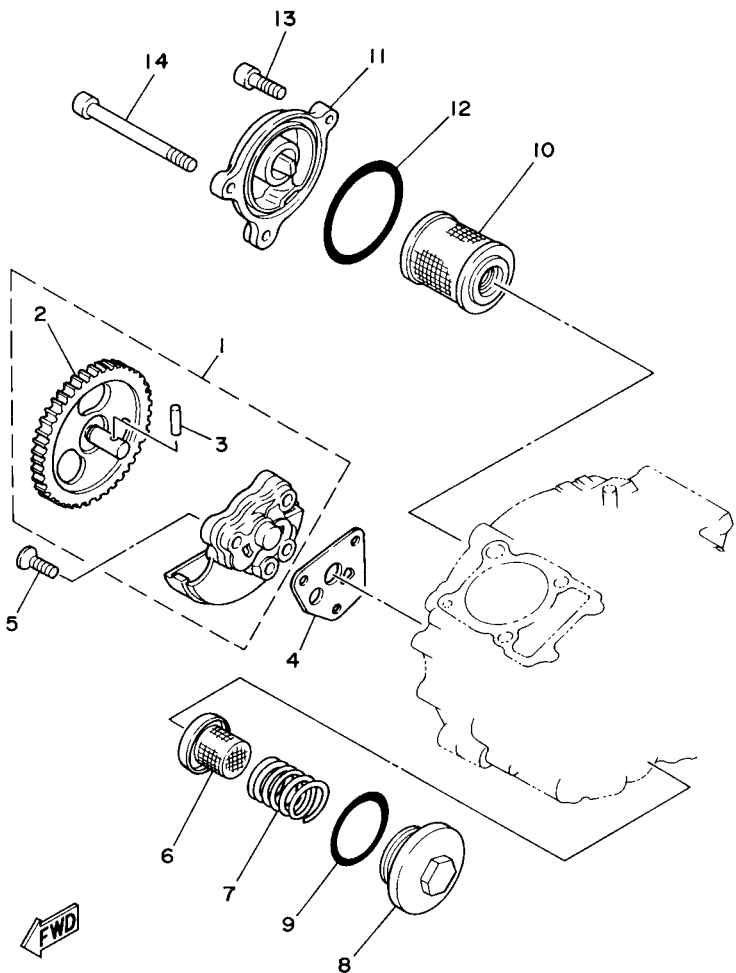

FIG. 6 INTAKE

REF. NO.	PART NO.	DESCRIPTION	USA	CAN	REMARKS
1	1P0-13586-00	JOINT, CARBURETOR 1	1	1	
2	93210-35895	O-RING	1	1	
3	91317-06020	BOLT	2	2	
4	90450-47001	HOSE CLAMP ASSY	1	1	
5	5UH-E4349-00	PIPE	1	1	(YMUS)
6	4XE-E4411-00	CASE, AIR CLEANER 1	1	1	(YMUS)
7	JN6-E4424-00	CLIP, CAP FITTING	3	3	(YMUS)
8	4XE-E4462-00	SEAL	1	1	(YMUS)
9	4XE-E4412-00	CAP, CLEANER CASE 1	1	1	(YMUS)
10	4XE-E4457-00	SEAL	1	1	(YMUS)
11	4XE-E4438-00	CLIP, DRAIN CLEANER	1	1	(YMUS)
12	4XE-E4450-00	ELEMENT ASSY, AIR CLEANER	1	1	(YMUS)
13	31A-14419-00	PIPE	1	1	
14	90450-56006	HOSE CLAMP ASSY	1	1	
15	1P0-E4453-00	JOINT, AIR CLEANER 1	1	1	(YMUS)
16	4XE-E4437-00	DUCT	1	1	(YMUS)
17	90460-58124	CLAMP, HOSE	1	1	
18	90450-56006	HOSE CLAMP ASSY	1	1	
19	31A-14419-00	PIPE	1	1	
20	4XE-E442F-00	PROTECTOR	1	1	(YMUS)
21	1P0-2179T-00	PLATE, EPA 3(CALIFORNIA)	1		

FIG. 7 OIL PUMP

REF. NO.	PART NO.	DESCRIPTION	USA	CAN	REMARKS
1	5XG-E3300-00	OIL PUMP ASSY	1	1	(YMUS)
2	5XG-E3326-00	.GEAR, PUMP DRIVEN 2	1	1	(YMUS)
3	93603-12801	.PIN, DOWEL	1	1	
4	4BE-13329-01	GASKET, PUMP COVER	1	1	
5	98707-06030	SCREW, FLAT HEAD	3	3	
6	51Y-13411-00	STRAINER, OIL	1	1	
7	90501-18576	SPRING, COMPRESSION	1	1	
8	5XG-E5351-00	PLUG, DRAIN	1	1	(YMUS)
9	93210-34800	O-RING	1	1	
10	3UH-E3440-00	ELEMENT ASSY, OIL CLEANER	1	1	(YMUS)
11	5XG-E3447-00	COVER, OIL ELEMENT	1	1	(YMUS)
12	93210-548A1	O-RING	1	1	
13	91317-06020	BOLT	2	2	
14	91317-06115	BOLT	1	1	



4KDF100-8060

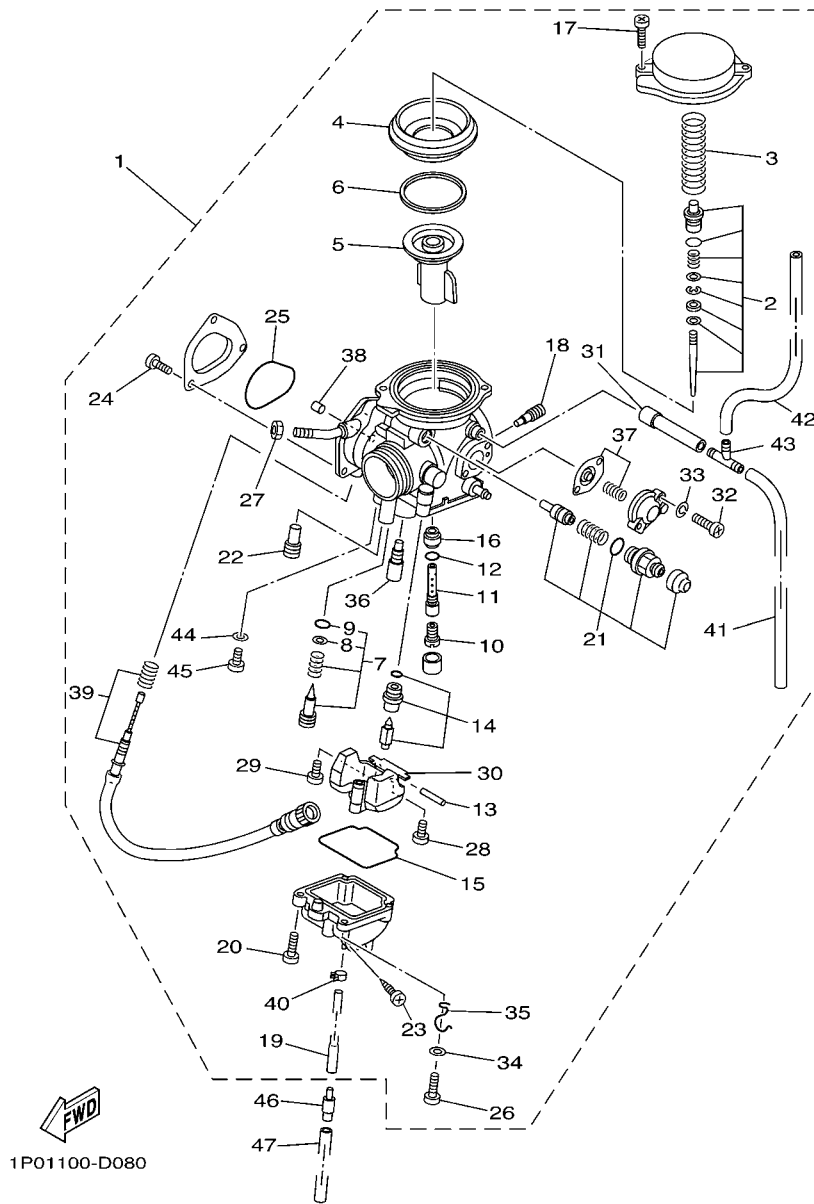

FIG. 8 CARBURETOR

REF. NO.	PART NO.	DESCRIPTION	USA	CAN	REMARKS
1	1P0-E4101-00	CARBURETOR ASSY 1	1	1	(YMUS)
2	1P0-1490J-00	.NEEDLE SET	1	1	
3	5DM-14933-00	.SPRING, DIAPHRAGM	1	1	
4	5GH-14940-10	.DIAPHRAGM ASSY	1	1	
5	5DM-14112-00	.VALVE, THROTTLE 1	1	1	
6	5GH-14918-10	.RING	1	1	
7	5FU-14105-10	.PILOT SCREW SET	1	1	WHITE SPRING
8	3H1-14962-00	..WASHER	1	1	
9	3H1-14147-00	..O-RING	1	1	
10	3G2-1414E-37	.JET, MAIN (# 93.8)	1	1	
11	5DM-14261-00	.HOLDER	1	1	
12	583-14561-00	.O-RING	1	1	
13	127-14186-00	.PIN, FLOAT	1	1	
14	4KM-14107-20	.NEEDLE VALVE SET	1	1	
15	5DM-14561-00	.O-RING	1	1	
16	5DM-14141-42	.NOZZLE, MAIN	1	1	
17	4KM-14216-00	.SCREW	2	2	
18	1HX-14231-16	.JET, MAIN (# 80)	1	1	
19	4KB-14193-20	.PIPE	1	1	
20	98580-04010	.SCREW, PAN HEAD	3	3	
21	5UH-1410A-00	.STARTER SET	1	1	
22	3G2-14231-12	.JET, MAIN (# 60)	1	1	
23	3FV-14191-00	.PLUG, DRAIN	1	1	
24	98507-04006	.SCREW, PAN HEAD	3	3	
25	5FU-E4147-00	.O-RING	1	1	(YMUS)
26	98507-04014	.SCREW, PAN HEAD	1	1	
27	522-14161-00	.NUT, CABLE ADJUSTING	1	1	

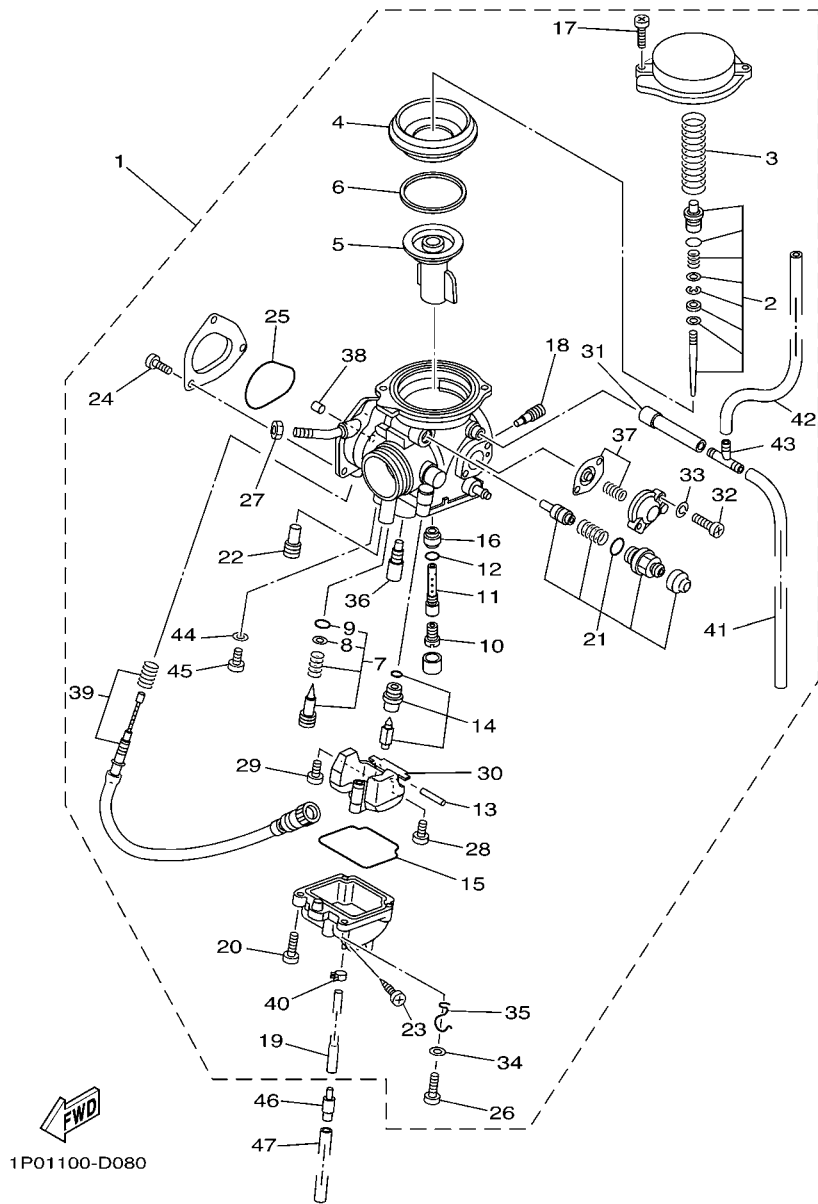
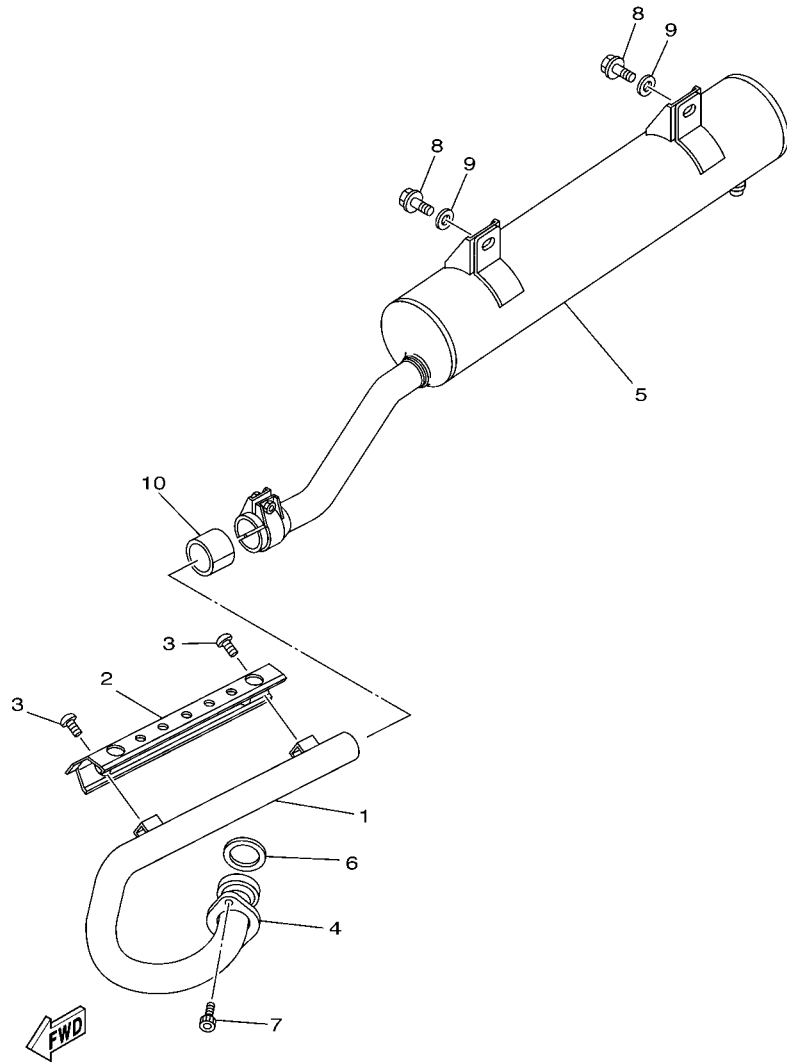

FIG. 8 CARBURETOR

REF. NO.	PART NO.	DESCRIPTION	USA	CAN	REMARKS
28	98507-04008	.SCREW, PAN HEAD	1	1	
29	1FN-14565-00	.SCREW	1	1	
30	5DM-14985-00	.FLOAT	1	1	
31	5FU-14197-00	.PIPE	1	1	
32	98501-04014	.SCREW, PAN HEAD	2	2	
33	92902-04100	.WASHER, SPRING	2	2	
34	92907-04600	.WASHER	1	1	
35	5GH-14937-00	.CLIP	1	1	
36	4KM-14142-17	.JET, PILOT (# 17.5)	1	1	
37	5ND-1490H-00	.DIAPHRAGM SET 5	1	1	
38	5FU-E4155-00	.GUIDE, CABLE	1	1	(YMUS)
39	5UH-14103-00	.THROTTLE SCREW SET	1	1	
40	4XE-14937-00	.CLIP	1	1	
41	5UH-14348-00	.PIPE 1	1	1	
42	7T9-14987-00	.HOSE	1	1	
43	5FU-14167-00	.CONNECTOR	1	1	
44	256-14956-01	.WASHER	1	1	
45	3DM-14216-00	.SCREW	1	1	
46	24W-14193-00	PIPE	1	1	
47	91A20-07010	TUBE, FLEXIBLE VINYL	1	1	

FIG. 9 EXHAUST



4XEA100-1090

REF. NO.	PART NO.	DESCRIPTION	USA	CAN	REMARKS
1	4XE-E4611-10	PIPE, EXHAUST 1	1	1	(YMUS)
2	4XE-E4628-00	PROTECTOR, EXHAUST PIPE	1	1	(YMUS)
3	4XE-E4767-00	SCREW	2	2	(YMUS)
4	4XE-E4612-10	NUT, RING	1	1	(YMUS)
5	4XE-E4710-20	MUFFLER ASSY 1	1	1	(YMUS)
6	4BE-14613-00	GASKET, EXHAUST PIPE	1	1	
7	9131P-06020	BOLT	2	2	(YMUS)
8	90105-10801	BOLT, FLANGE	2	2	(YMUS)
9	90201-101J1	WASHER, PLATE	2	2	
10	3YF-14714-00	GASKET, MUFFLER	1	1	

FIG. 10 CRANKCASE

REF. NO.	PART NO.	DESCRIPTION	USA	CAN	REMARKS
1	5XG-E5150-00	CRANKCASE ASSY	1	1	(YMUS)
2	91317-06035	.BOLT	4	4	
3	99530-10014	.PIN, DOWEL	2	2	
4	91317-06085	.BOLT	1	1	
5	99530-12016	PIN, DOWEL	2	2	
6	98507-06030	SCREW, PAN HEAD	7	7	
7	98507-06040	SCREW, PAN HEAD	1	1	
8	98507-06060	SCREW, PAN HEAD	1	1	
9	98507-06085	SCREW, PAN HEAD	1	1	
10	90110-06817	BOLT, HEXAGON SOCKET HEAD	1	1	(YMUS)
11	98507-06075	SCREW, PAN HEAD	1	1	

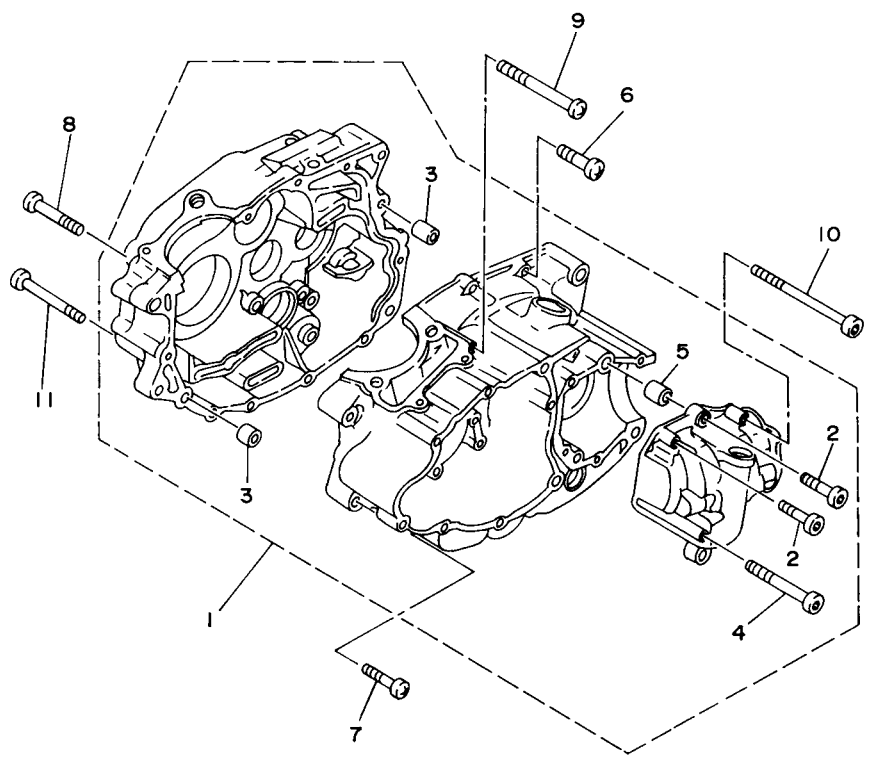

4BDJ100-7100

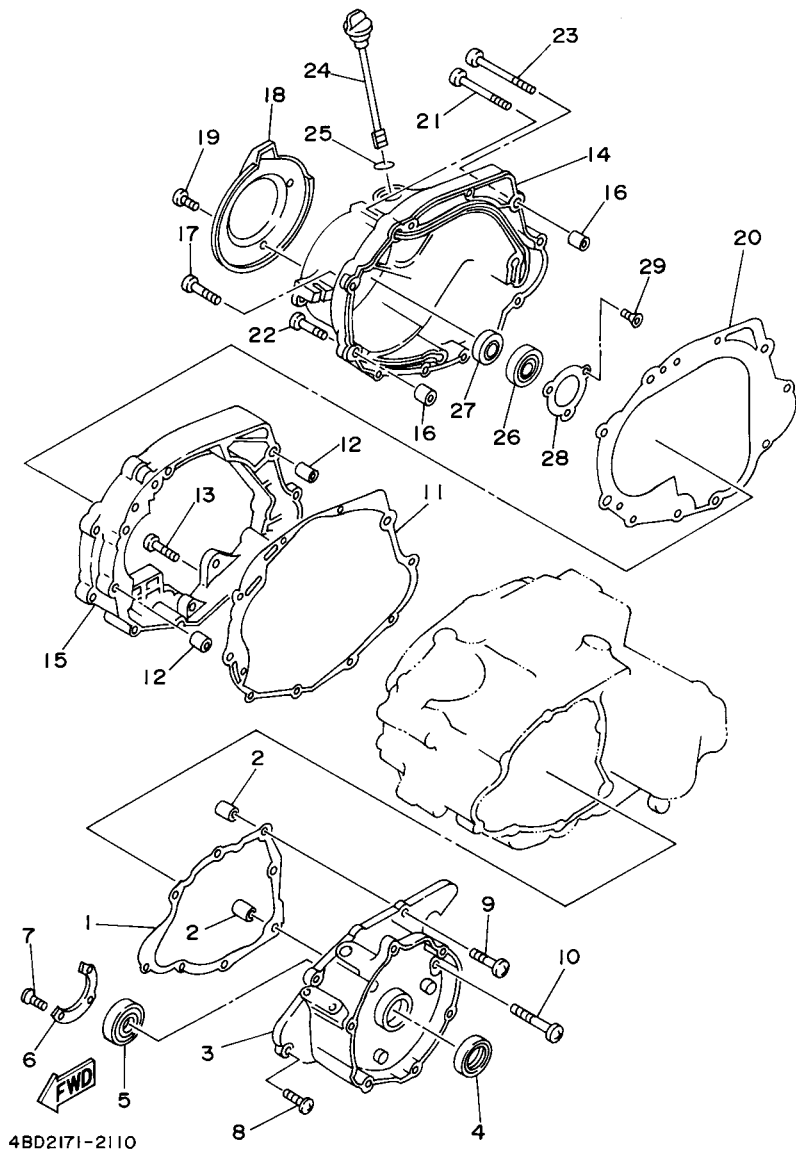
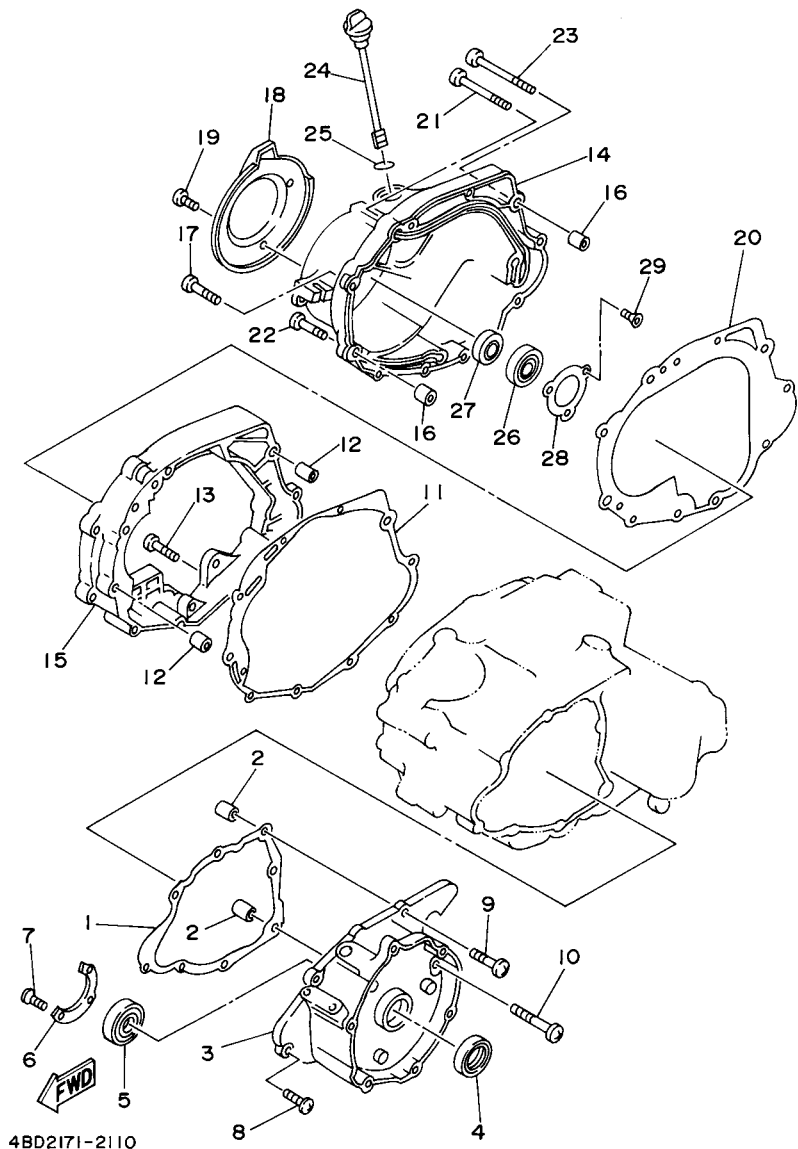

FIG. 11 CRANKCASE COVER 1

REF. NO.	PART NO.	DESCRIPTION	USA	CAN	REMARKS
1	4BD-15451-01	GASKET, CRANKCASE COVER 1	1	1	
2	99530-12016	PIN, DOWEL	2	2	
3	5XG-E5787-00	ADAPTOR	1	1	(YMUS)
4	93103-28141	OIL SEAL	1	1	
5	93306-078Y0	BEARING	1	1	(YMUS)
6	21V-15719-00	WASHER, THRUST	1	1	
7	98707-05016	SCREW, FLAT HEAD	3	3	
8	98507-06025	SCREW, PAN HEAD	5	5	
9	98507-06040	SCREW, PAN HEAD	2	2	
10	98507-06060	SCREW, PAN HEAD	1	1	
11	4BD-15462-00	GASKET, CRANKCASE COVER 3	1	1	
12	99530-12016	PIN, DOWEL	2	2	
13	98507-06040	SCREW, PAN HEAD	3	3	
14	5XG-E5431-00	COVER, CRANKCASE 3	1	1	(YMUS)
15	5XG-E5317-00	SPACER, ENGINE MOUNT	1	1	(YMUS)
16	99530-12016	PIN, DOWEL	2	2	
17	98507-06040	SCREW, PAN HEAD	2	2	
18	5XG-E5499-00	PROTECTOR, COVER	1	1	(YMUS)
19	98907-06014	SCREW, BIND	3	3	
20	4BD-15463-01	GASKET, CARBURETOR COVER 2	1	1	
21	98507-06070	SCREW, PAN HEAD	5	5	
22	98507-06040	SCREW, PAN HEAD	1	1	
23	98507-06080	SCREW, PAN HEAD	1	1	
24	5XG-E5362-00	PLUG, OIL LEVEL	1	1	(YMUS)
25	93210-19841	O-RING	1	1	
26	93306-203X0	BEARING	1	1	(YMUS)
27	93101-17113	OIL SEAL	1	1	

FIG. 11 CRANKCASE COVER 1



REF. NO.	PART NO.	DESCRIPTION	USA	CAN				REMARKS
28	5XG-E5381-00	PLATE, BEARING COVER	1	1				(YMUS)
29	98707-06018	SCREW, FLAT HEAD	3	3				

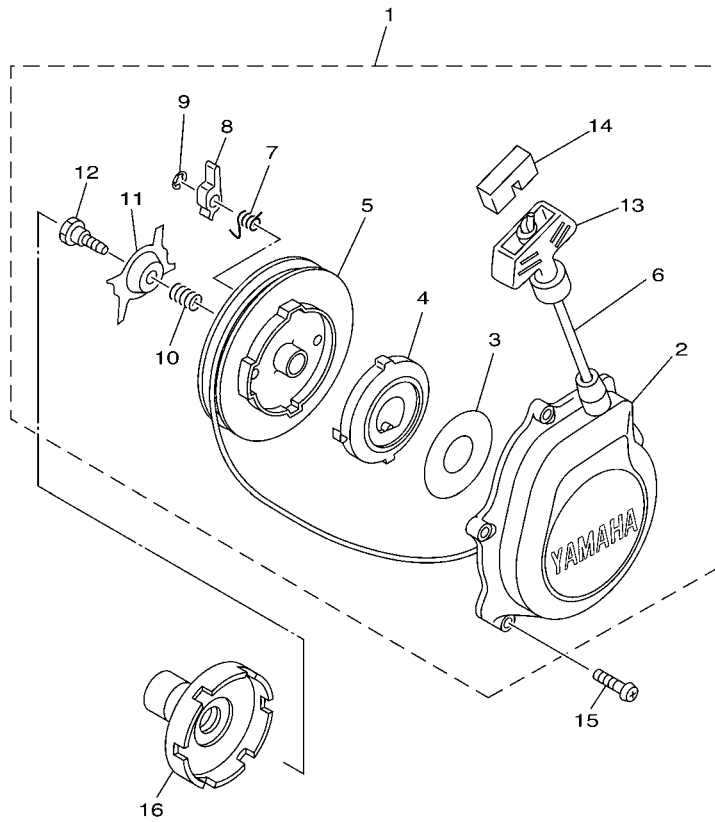
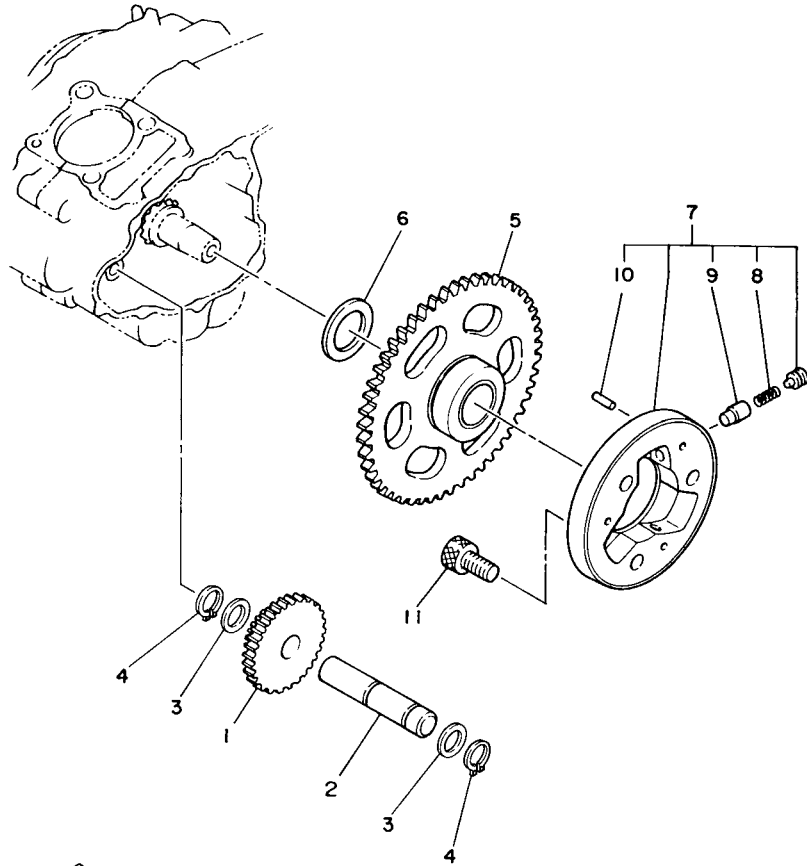

FIG. 12 STARTER

REF. NO.	PART NO.	DESCRIPTION	USA	CAN		REMARKS
1	4XE-E5710-00	STARTER ASSY	1	1		(YMUS)
2	4XE-E5711-00	.CASE, STARTER	1	1		(YMUS)
3	4XE-E5789-00	.DAMPER	1	1		(YMUS)
4	4XE-E5713-00	.SPRING, STARTER	1	1		(YMUS)
5	4XE-E5714-00	.DRUM, SHEAVE	1	1		(YMUS)
6	4XE-E5751-00	.WIRE, STARTER	1	1		(YMUS)
7	4XE-E5767-00	.SPRING	2	2		(YMUS)
8	4XE-E5741-00	.PAWL, DRIVE	2	2		(YMUS)
9	4XE-E5744-00	.CIRCLIP	2	2		(YMUS)
10	4XE-E5715-00	.SPRING, FRICTION	1	1		(YMUS)
11	4XE-E5716-00	.PLATE, DRIVE	1	1		(YMUS)
12	4XE-E5793-00	.SCREW	1	1		(YMUS)
13	4XE-E5755-00	.HANDLE, STARTER	1	1		(YMUS)
14	4XE-E5779-00	.COVER	1	1		(YMUS)
15	98507-06020	SCREW, PAN HEAD	6	6		
16	5XG-E5723-00	PULLEY, STARTER	1	1		(YMUS)



4XE1110-9120



2HT110-7120

FIG. 13 STARTER CLUTCH

REF. NO.	PART NO.	DESCRIPTION	USA	CAN			REMARKS
1	1P0-E5512-00	GEAR, IDLER 1	1	1			(YMUS)
2	5XG-E5521-00	SHAFT 1	1	1			(YMUS)
3	90201-128C9	WASHER, PLATE	2	2			(YMUS)
4	99009-12400	CIRCLIP	2	2			
5	5XG-E5517-00	GEAR, IDLER 2	1	1			(YMUS)
6	90201-25290	WASHER, PLATE	1	1			
7	31A-15580-00	STARTER CLUTCH OUTER ASSY	1	1			
8	90501-04503	.SPRING, COMPRESSION	3	3			
9	1J7-15583-01	.CAP, STARTER CLUTCH SPRING	3	3			
10	93615-12088	.PIN, DOWEL	3	3			
11	91317-08016	BOLT	3	3			

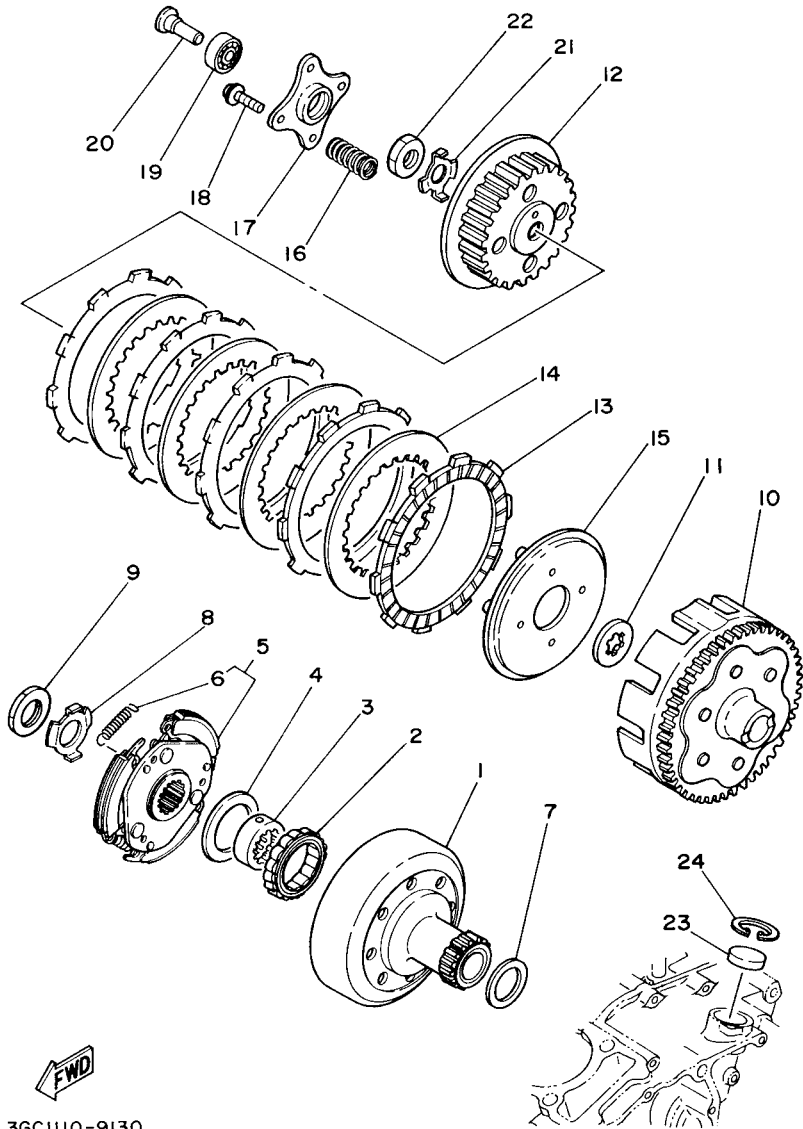

3GC1110-9130

FIG. 14 CLUTCH

REF. NO.	PART NO.	DESCRIPTION	USA	CAN	REMARKS
1	5XG-E6611-00	CLUTCH HOUSING COMP.	1	1	(YMUS)
2	21V-16664-00	BEARING, ONE WAY	1	1	
3	5XG-E6665-00	RETAINER, BEARING	1	1	(YMUS)
4	90201-404M6	WASHER, PLATE	1	1	
5	5XG-E6620-00	CLUTCH CARRIER ASSY	1	1	(YMUS)
6	5XG-E6626-00	.SPRING, CLUTCH WEIGHT 1	3	3	(YMUS)
7	90201-266F6	WASHER, PLATE	1	1	
8	90215-22259	WASHER, LOCK	1	1	
9	90170-22371	NUT	1	1	
10	5XG-E6150-00	PRIMARY DRIVEN GEAR COMP.	1	1	(YMUS)
11	5XG-E6154-00	PLATE, THRUST 1	1	1	(YMUS)
12	5XG-E6371-00	BOSS, CLUTCH	1	1	(YMUS)
13	5XG-E6321-00	PLATE, FRICTION	5	5	(YMUS)
14	5XG-E6324-00	PLATE, CLUTCH 1	4	4	(YMUS)
15	5XG-E6351-00	PLATE, PRESSURE 1	1	1	(YMUS)
16	90501-243J7	SPRING, COMPRESSION	4	4	
17	5XG-E6352-00	PLATE, PRESSURE 2	1	1	(YMUS)
18	90159-05011	SCREW, WITH WASHER	4	4	
19	93306-00006	BEARING (B6000)	1	1	
20	21V-16358-00	PLATE, PUSH	1	1	
21	90215-14186	WASHER, LOCK	1	1	
22	90170-14839	NUT	1	1	(YMUS)
23	90338-26136	PLUG	1	1	
24	93420-28055	CIRCLIP	1	1	

FIG. 15 TRANSMISSION

REF. NO.	PART NO.	DESCRIPTION	USA	CAN	REMARKS
1	5XG-E7401-00	MAIN AXLE ASSY	1	1	(YMUS)
2	24W-17151-02	GEAR, 5TH PINION (28T)	1	1	
3	90209-17285	WASHER	1	1	
4	93410-20038	CIRCLIP	1	1	
5	5XG-E7131-00	GEAR, 3RD PINION (22T)	1	1	(YMUS)
6	5XG-E7141-00	GEAR, 4TH PINION (25T)	1	1	(YMUS)
7	5XG-E7121-00	GEAR, 2ND PINION (19T)	1	1	(YMUS)
8	93306-204Y6	BEARING	1	1	(YMUS)
9	93101-15101	OIL SEAL	1	1	
10	93306-202X2	BEARING	1	1	(YMUS)
11	5XG-E7402-00	DRIVE AXLE ASSY	1	1	(YMUS)
12	5XG-E7221-00	GEAR, 2ND WHEEL (34T)	1	1	(YMUS)
13	1P0-E7241-00	GEAR, 4TH WHEEL (26T)	1	1	(YMUS)
14	5XG-E7231-00	GEAR, 3RD WHEEL (29T)	1	1	(YMUS)
15	4BD-17251-00	GEAR, 5TH WHEEL (23T)	1	1	
16	90209-18208	WASHER	1	1	
17	93410-22039	CIRCLIP	1	1	
18	5XG-E7211-00	GEAR, 1ST WHEEL (34T)	1	1	(YMUS)
19	90209-23241	WASHER	1	1	
20	93410-26067	CIRCLIP	1	1	
21	90201-15700	WASHER, PLATE	1	1	
22	5XG-E7558-00	PLATE, BEARING	1	1	(YMUS)
23	90149-08152	SCREW	3	3	
24	93306-202X2	BEARING	1	1	(YMUS)

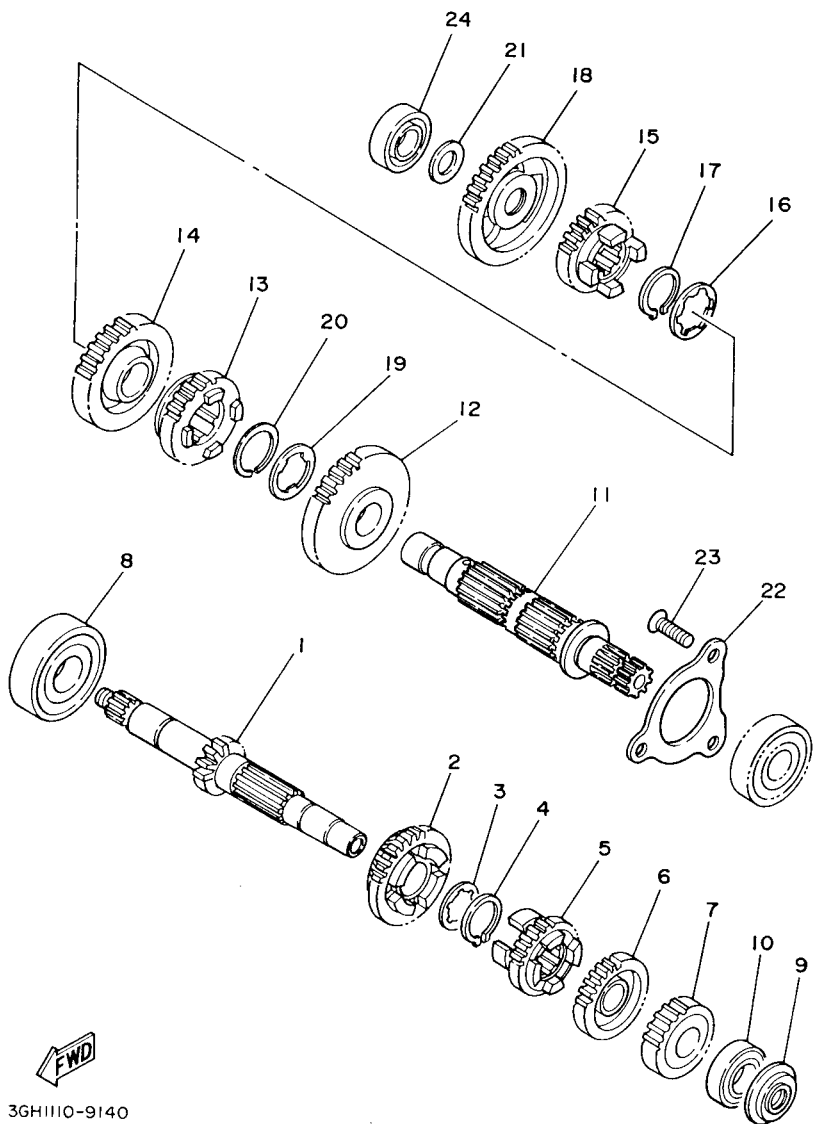

3GH1110-9140

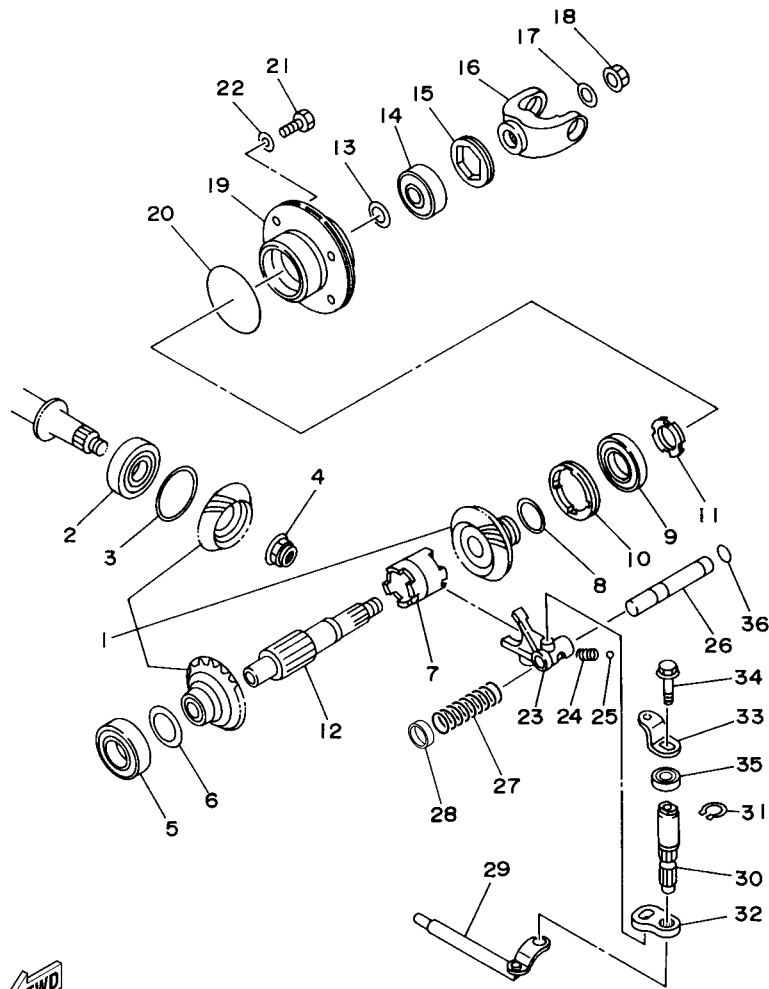

1P01100-D160

FIG. 16 MIDDLE DRIVE GEAR

REF. NO.	PART NO.	DESCRIPTION	USA	CAN	REMARKS
1	52G-Y1754-00	MIDDLE GEAR COMP.	1	1	
2	93306-304YE	BEARING	1	1	(YMUS)
3	24W-17537-10	SHIM, THRUST (0.13T)	1	1	UR
	24W-17537-20	SHIM, THRUST (0.15T)	1	1	UR
	24W-17537-30	SHIM, THRUST (0.2T)	1	1	UR
	24W-17537-40	SHIM, THRUST (0.3T)	1	1	UR
	24W-17537-50	SHIM, THRUST (0.4T)	1	1	UR
	24W-17537-60	SHIM, THRUST (0.5T)	1	1	UR
4	90179-16651	NUT	1	1	
5	93306-006Y3	BEARING	1	1	(YMUS)
6	52G-17531-01	SHIM, PINION (0.1T)	1	1	UR
	52G-17531-11	SHIM, PINION (0.15T)	1	1	UR
	52G-17531-21	SHIM, PINION (0.2T)	1	1	UR
	52G-17531-31	SHIM, PINION (0.3T)	1	1	UR
	52G-17531-41	SHIM, PINION (0.4T)	1	1	UR
	52G-17531-51	SHIM, PINION (0.5T)	1	1	UR
7	5XG-E7285-00	CLUTCH, DOG	1	1	(YMUS)
8	52G-17967-20	SHIM, (0.15T)	1	1	UR
	52G-17967-30	SHIM, (0.2T)	1	1	UR
	52G-17967-40	SHIM, (0.3T)	1	1	UR
9	93306-078Y0	BEARING	1	1	(YMUS)
10	90179-55464	NUT	1	1	
11	90179-28465	NUT	1	1	
12	5XG-E7553-00	SHAFT, MIDDLE DRIVEN	1	1	(YMUS)
13	5XG-E7968-00	SHIM, (1.0T)	1	1	UR (YMUS)
	5XG-E7968-10	SHIM, (1.1T)	1	1	UR (YMUS)
	5XG-E7968-20	SHIM, (1.2T)	1	1	UR (YMUS)



1P01100-D160

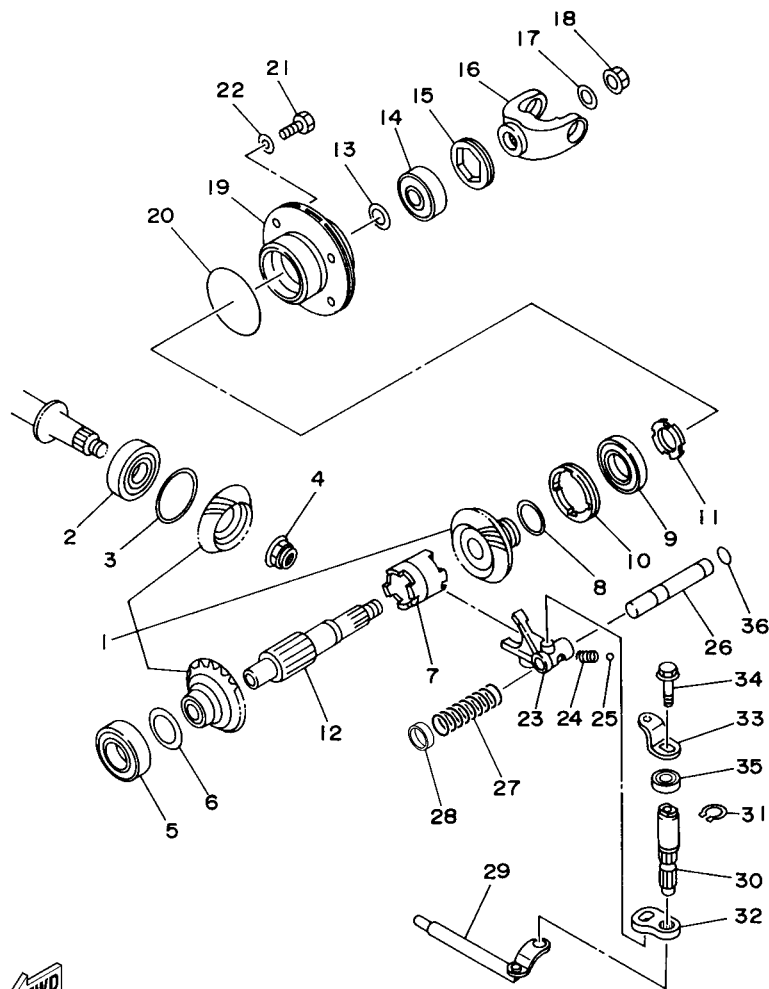
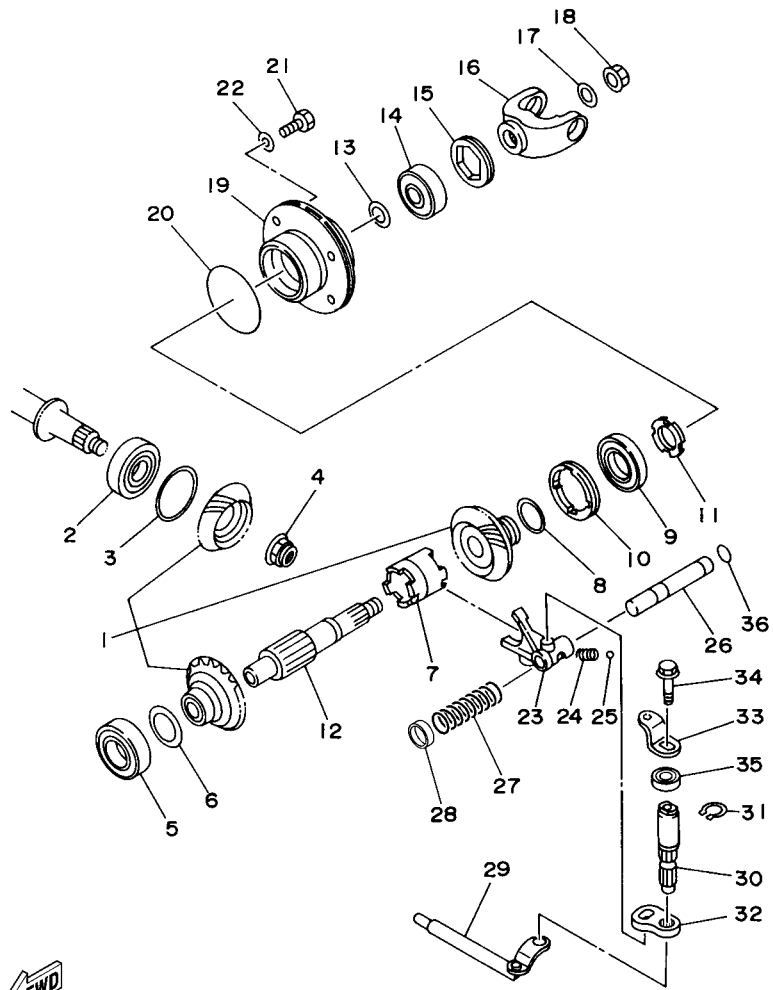

FIG. 16 MIDDLE DRIVE GEAR

REF. NO.	PART NO.	DESCRIPTION	USA	CAN	REMARKS
13	5XG-E7968-30	SHIM, (1.3T)	1	1	UR (YMUS)
	5XG-E7968-40	SHIM, (1.4T)	1	1	UR (YMUS)
	5XG-E7968-50	SHIM, (1.5T)	1	1	UR (YMUS)
	5XG-E7968-60	SHIM, (1.6T)	1	1	UR (YMUS)
	5XG-E7968-70	SHIM, (1.7T)	1	1	UR (YMUS)
	5XG-E7968-80	SHIM, (1.8T)	1	1	UR (YMUS)
	5XG-E7968-90	SHIM, (1.9T)	1	1	UR (YMUS)
14	93399-99917	BEARING	1	1	
15	1P0-E7642-00	NUT, BEARING	1	1	(YMUS)
16	5XG-E7556-00	YOKE, JOINT	1	1	(YMUS)
17	90201-125F7	WASHER, PLATE	1	1	
18	90179-12248	NUT	1	1	
19	5XG-E7551-00	HOUSING, BEARING	1	1	(YMUS)
20	93210-53800	O-RING	1	1	
21	97027-08025	BOLT	4	4	
22	92907-08600	WASHER, PLATE	4	4	
23	5XG-E8514-00	FORK, SHIFT 4	1	1	(YMUS)
24	90501-101A5	SPRING, COMPRESSION	1	1	
25	93501-04805	BALL	1	1	
26	5XG-E8534-00	BAR, SHIFT FORK GUIDE	1	1	(YMUS)
27	90501-13800	SPRING, COMPRESSION	1	1	(YMUS)
28	1P0-E8323-00	CAP, SPRING	1	1	(YMUS)
29	5XG-E812A-00	STOPPER SHAFT ASSY	1	1	(YMUS)
30	5XG-E8197-00	SHAFT	1	1	(YMUS)
31	99009-14400	CIRCLIP	1	1	
32	5XG-E8451-00	LEVER, SHIFT	1	1	(YMUS)
33	5XG-E8198-00	LEVER	1	1	(YMUS)

FIG. 16 MIDDLE DRIVE GEAR



1P01100-D160

REF. NO.	PART NO.	DESCRIPTION	USA	CAN	REMARKS
34	95817-06016	BOLT, FLANGE	1	1	
35	93102-14856	OIL SEAL	1	1	
36	93210-09165	O-RING	1	1	

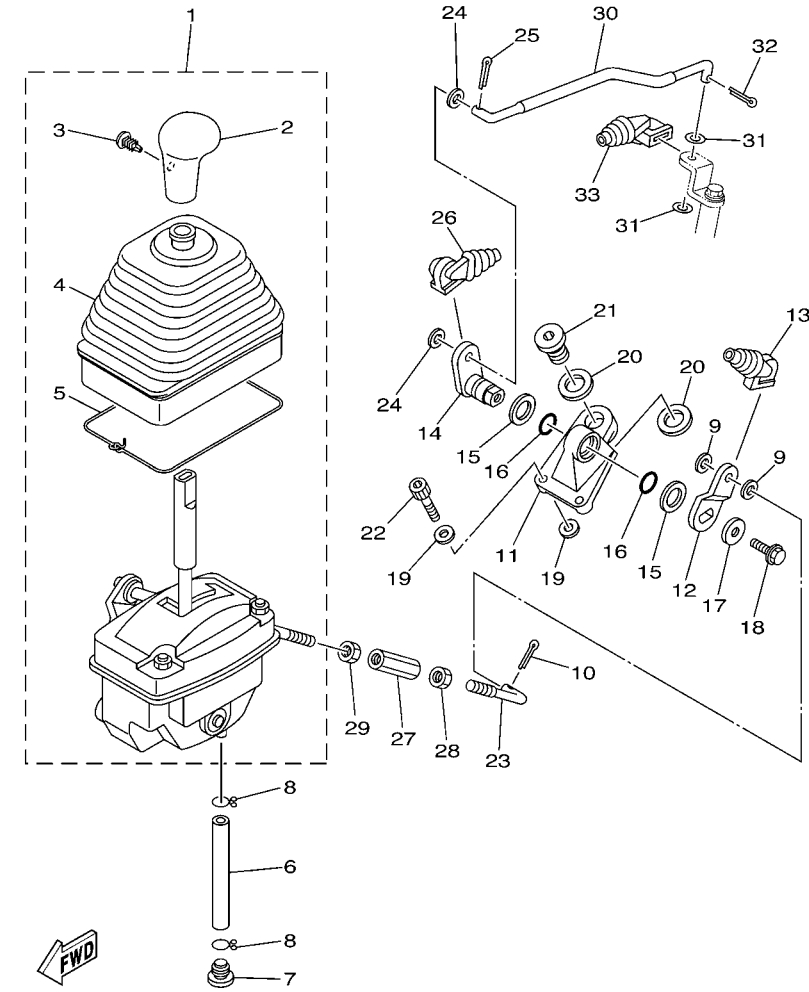

1P01100-D170

FIG. 17 DRIVE SELECTOR

REF. NO.	PART NO.	DESCRIPTION	USA	CAN	REMARKS
1	1P0-18300-00	SHIFTER ASSY	1	1	
2	1P0-18174-00	.KNOB, SHIFT LEVER	1	1	
3	90269-05055	.RIVET	1	1	
4	5GH-18131-00	.BOOT, SEALING	1	1	
5	5GH-18617-00	.STOPPER, RUBBER	1	1	
6	90446-16001	HOSE (L90)	1	1	
7	5ND-E4191-00	PLUG, DRAIN	1	1	(YMUS)
8	90467-15012	CLIP	2	2	
9	92907-06200	WASHER	2	2	
10	91401-20015	PIN, COTTER	1	1	
11	1P0-E8164-00	KNOB, SHIFTER	1	1	(YMUS)
12	1P0-E8191-00	LEVER	1	1	(YMUS)
13	5XG-E8154-10	COVER, DUST	1	1	(YMUS)
14	1P0-E8341-00	SHAFT, RINK	1	1	(YMUS)
15	90201-144J2	WASHER, PLATE	2	2	
16	93210-14805	O-RING	2	2	
17	90201-06008	WASHER, PLATE	1	1	
18	95817-06016	BOLT, FLANGE	1	1	
19	90201-067P3	WASHER, PLATE	4	4	
20	90201-147P2	WASHER, PLATE	2	2	
21	90340-14107	PLUG, STRAIGHT SCREW	1	1	
22	91317-06020	BOLT	2	2	
23	5XG-E8117-00	JOINT, ROD 2	1	1	(YMUS)
24	92907-06200	WASHER	2	2	
25	91401-20015	PIN, COTTER	1	1	
26	5XG-E8154-00	COVER, DUST	1	1	(YMUS)
27	52G-18187-00	NUT, ADJUST	1	1	

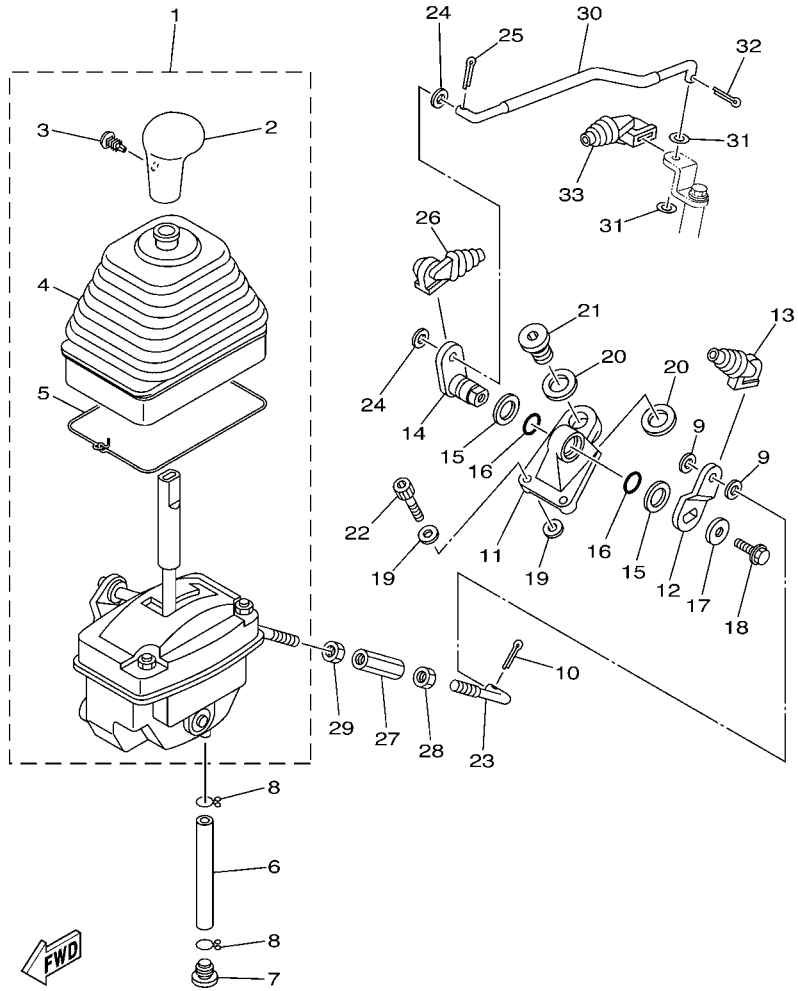

1P01100-D170

FIG. 17 DRIVE SELECTOR

REF. NO.	PART NO.	DESCRIPTION	USA	CAN	REMARKS
28	95317-08600	NUT	1	1	
29	90170-08261	NUT	1	1	
30	5XG-E8116-00	JOINT, ROD 1	1	1	(YMUS)
31	92907-06200	WASHER	2	2	
32	91401-20015	PIN, COTTER	1	1	
33	5XG-E8154-10	COVER, DUST	1	1	(YMUS)

FIG. 18 SHIFT CAM & FORK

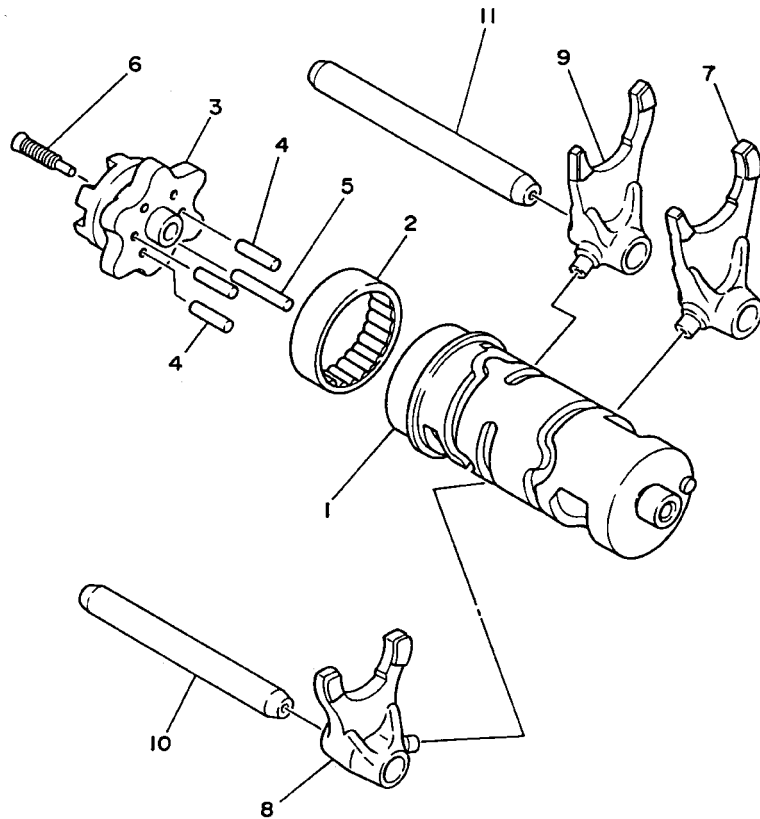

REF. NO.	PART NO.	DESCRIPTION	USA	CAN	REMARKS
1	52G-18540-01	SHIFT CAM ASSY	1	1	
2	93315-23607	BEARING	1	1	
3	5XG-E8185-00	SEGMENT	1	1	(YMUS)
4	93604-16092	PIN, DOWEL	4	4	
5	93604-20156	PIN, DOWEL	1	1	
6	90151-06013	SCREW, COUNTERSUNK	1	1	
7	5XG-E8513-00	FORK, SHIFT 3	1	1	(YMUS)
8	5XG-E8511-00	FORK, SHIFT 1	1	1	(YMUS)
9	5XG-E8512-00	FORK, SHIFT 2	1	1	(YMUS)
10	5XG-E8531-00	BAR, SHIFT FORK GUIDE 1	1	1	(YMUS)
11	5XG-E8535-00	BAR, SHIFT FORK GUIDE 2	1	1	(YMUS)



52G100-5181

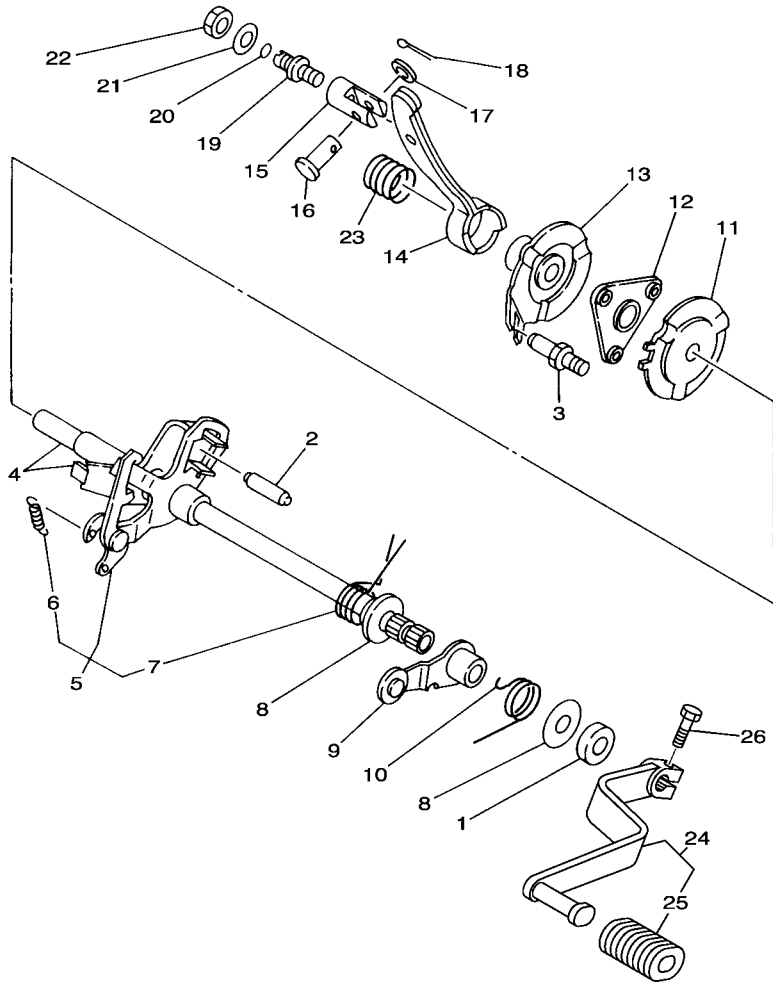

 1P01100-D190

FIG. 19 SHIFT SHAFT

REF. NO.	PART NO.	DESCRIPTION	USA	CAN	REMARKS
1	93102-12803	OIL SEAL	1	1	
2	93608-30839	PIN, DOWEL	1	1	
3	5XG-E8177-00	BOLT, STOPPER	1	1	(YMUS)
4	5XG-E8103-00	SHIFT SHAFT COMP.	1	1	(YMUS)
5	5XG-E8120-00	SHIFT LEVER ASSY	1	1	(YMUS)
6	90506-08227	.SPRING, TENSION	1	1	
7	90508-29570	.SPRING, TORSION	1	1	
8	90201-12588	WASHER, PLATE	2	2	
9	5XG-E8140-00	STOPPER LEVER ASSY	1	1	(YMUS)
10	90508-26539	SPRING, TORSION	1	1	
11	24W-18179-00	GUIDE	1	1	
12	21V-18181-00	HOLDER, PAWL	1	1	
13	24W-18104-00	SHIFT GUIDE COMP.	1	1	
14	5XG-E817A-00	ARM, SHIFT 3	1	1	(YMUS)
15	5XG-E8126-00	PIN, LEVER	1	1	(YMUS)
16	5XG-E8118-00	PIN, JOINT	1	1	(YMUS)
17	92907-08600	WASHER, PLATE	1	1	
18	91401-16012	PIN, COTTER	1	1	
19	5XG-E8127-00	STOPPER, SCREW	1	1	(YMUS)
20	93210-07590	O-RING	1	1	
21	90201-08093	WASHER, PLATE	1	1	
22	95307-08700	NUT	1	1	
23	90501-16768	SPRING, COMPRESSION	1	1	
24	1P0-18110-00	SHIFT PEDAL ASSY	1	1	
25	22N-18113-00	.COVER, SHIFT PEDAL	1	1	
26	9701P-06020	BOLT	1	1	(YMUS)

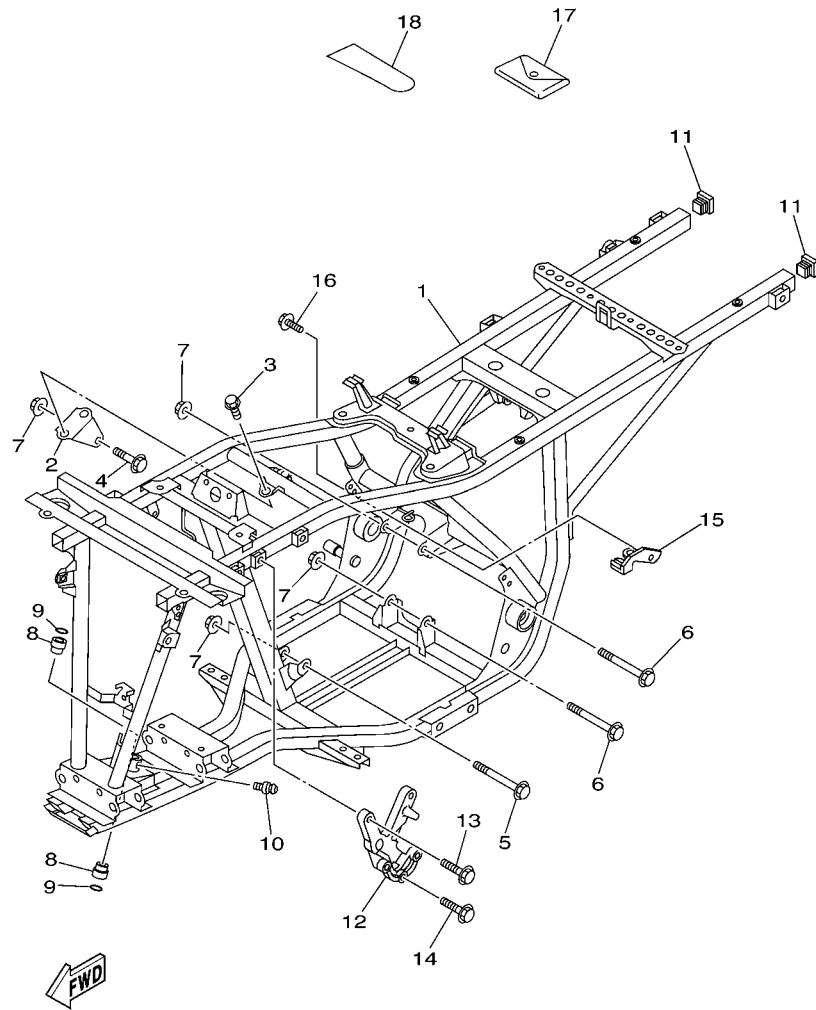

1P01100-D200

FIG. 20 FRAME

REF. NO.	PART NO.	DESCRIPTION	USA	CAN	REMARKS
1	1P0-F1110-00	FRAME COMP.	1	1	(YMUS)
2	4XE-F1315-00	STAY, ENGINE 2	1	1	(YMUS)
3	9581P-08012	BOLT, FLANGE	2	2	(YMUS)
4	90105-08805	BOLT, FLANGE	1	1	(YMUS)
5	90105-08888	BOLT, FLANGE	1	1	(YMUS)
6	90105-08806	BOLT, FLANGE	2	2	(YMUS)
7	90179-08893	NUT	4	4	(YMUS)
8	90381-15040	BUSH, SOLID	2	2	
9	93210-15414	O-RING	2	2	
10	93700-06004	NIPPLE, GREASE	1	1	
11	5FU-F111A-00	CAP, MAIN PIPE	2	2	(YMUS)
12	1P0-F1585-00	ARM	1	1	(YMUS)
13	95827-08020	BOLT, FLANGE	2	2	
14	95827-08020	BOLT, FLANGE	3	3	
15	1P0-F1453-00	BRACKET, SWITCH	1	1	(YMUS)
16	9582P-06012	BOLT, FLANGE	1	1	(YMUS)
17	5ND-F8100-00	TOOL KIT	1	1	(YMUS)
18	1NV-2811A-01	GAUGE, AIR	1	1	

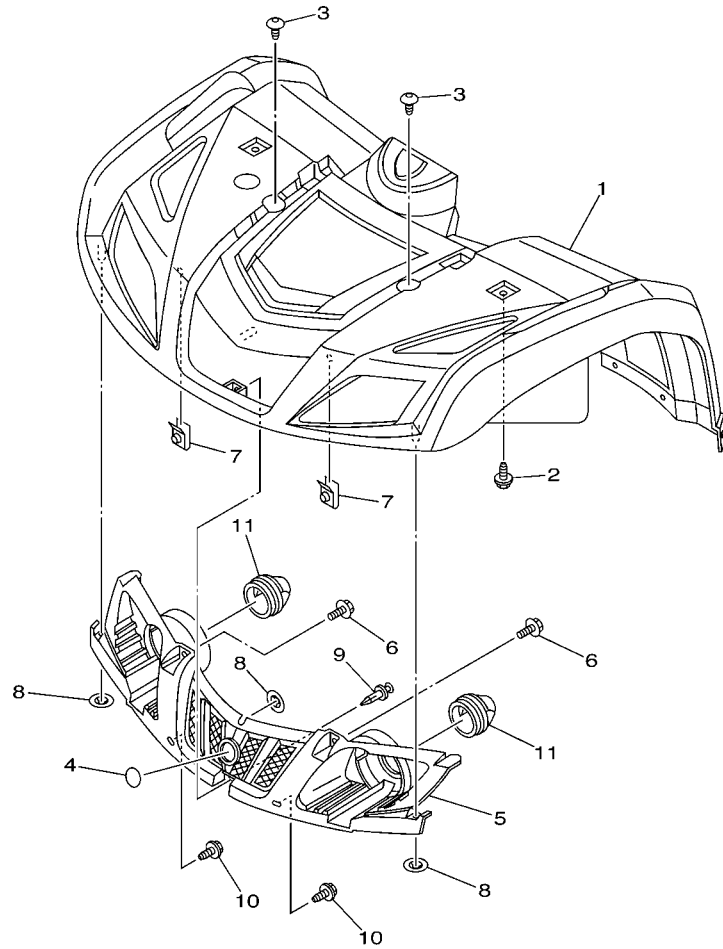

1P01100-D210

FIG. 21 FRONT FENDER

REF. NO.	PART NO.	DESCRIPTION	USA	CAN		REMARKS
1	1P0-F1500-00	FRONT FENDER ASSY	1			FOR RTR (YMUS)
	1P0-F1500-10	FRONT FENDER ASSY	1			FOR PDG (YMUS)
	1P0-F1500-20	FRONT FENDER ASSY	1	1		FOR DPBSN (YMUS)
2	90119-06060	BOLT, WITH WASHER	2	2		
3	90149-05299	SCREW	2	2		
4	5FU-F175B-01	TUNING FORK MARK	1	1		(YMUS)
5	5UH-F8309-00	GRILLE, FRONT	1	1		(YMUS)
6	90119-06060	BOLT, WITH WASHER	2	2		
7	90183-06053	NUT, SPRING	2	2		
8	90183-08800	NUT, SPRING	3	3		(YMUS)
9	90269-06804	RIVET	1	1		(YMUS)
10	90119-06060	BOLT, WITH WASHER	2	2		
11	5UH-F8349-00	CAP	2	2		(YMUS)

FIG. 22 REAR FENDER

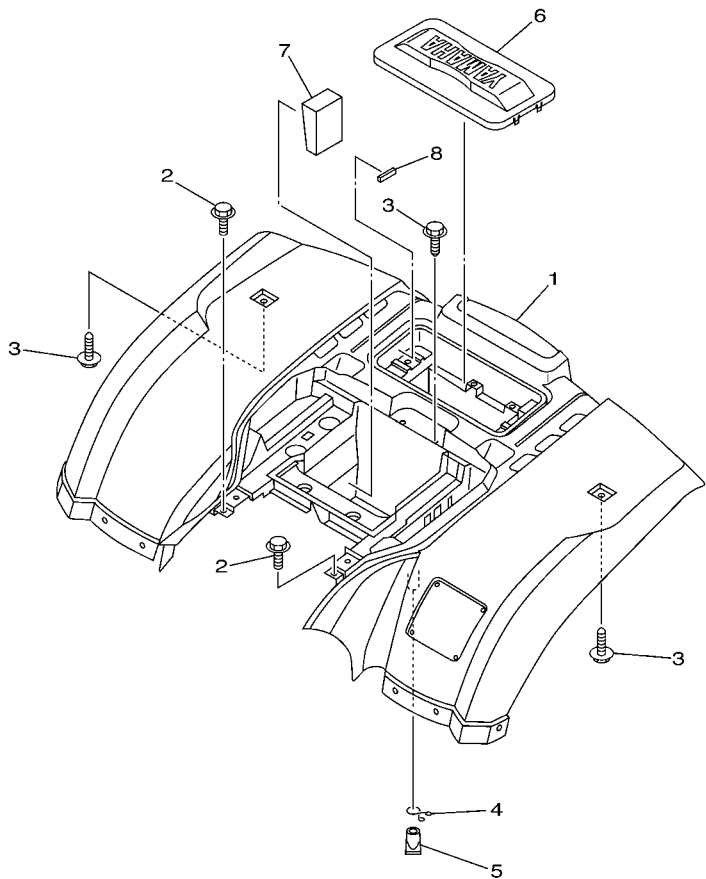

1P01100-D220

REF. NO.	PART NO.	DESCRIPTION	USA	CAN	REMARKS
1	1P0-F1600-00	REAR FENDER ASSY.	1		FOR RTR (YMUS)
	1P0-F1600-10	REAR FENDER ASSY.	1		FOR PDG (YMUS)
	1P0-F1600-20	REAR FENDER ASSY.	1	1	FOR DPBSN (YMUS)
2	90119-06227	BOLT, WITH WASHER	2	2	
3	90119-06060	BOLT, WITH WASHER	3	3	
4	90467-16195	CLIP	1	1	
5	5BF-1443E-00	PIPE, DRAIN	1	1	
6	1P0-F1651-00	COVER, REAR FENDER	1		FOR RTR (YMUS)
	1P0-F1651-10	COVER, REAR FENDER	1		FOR PDG (YMUS)
	1P0-F1651-50	COVER, REAR FENDER	1	1	FOR DPBSN (YMUS)
7	1P0-F1649-00	DAMPER	1	1	(YMUS)
8	1P0-F4285-00	CLAMP, DAMPER	2	2	(YMUS)

FIG. 23 SIDE COVER

REF. NO.	PART NO.	DESCRIPTION	USA	CAN					REMARKS
1	1P0-F171A-00	COVER, TOP	1						FOR RTR (YMUS)
	1P0-F171A-10	COVER, TOP	1						FOR PDG (YMUS)
	1P0-F171A-50	COVER, TOP	1	1					FOR DPBSN (YMUS)
2	90269-05001	RIVET	2	2					
3	90269-08813	RIVET	2	2					(YMUS)

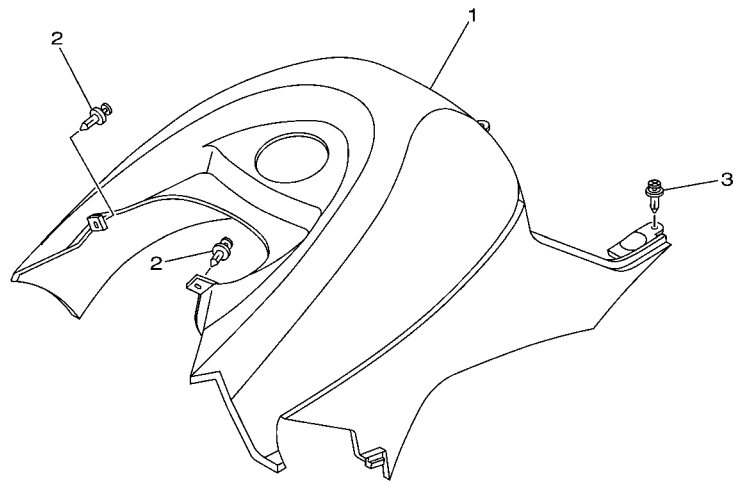

FWD
1P01100-D230

D3

FIG. 24 REAR ARM

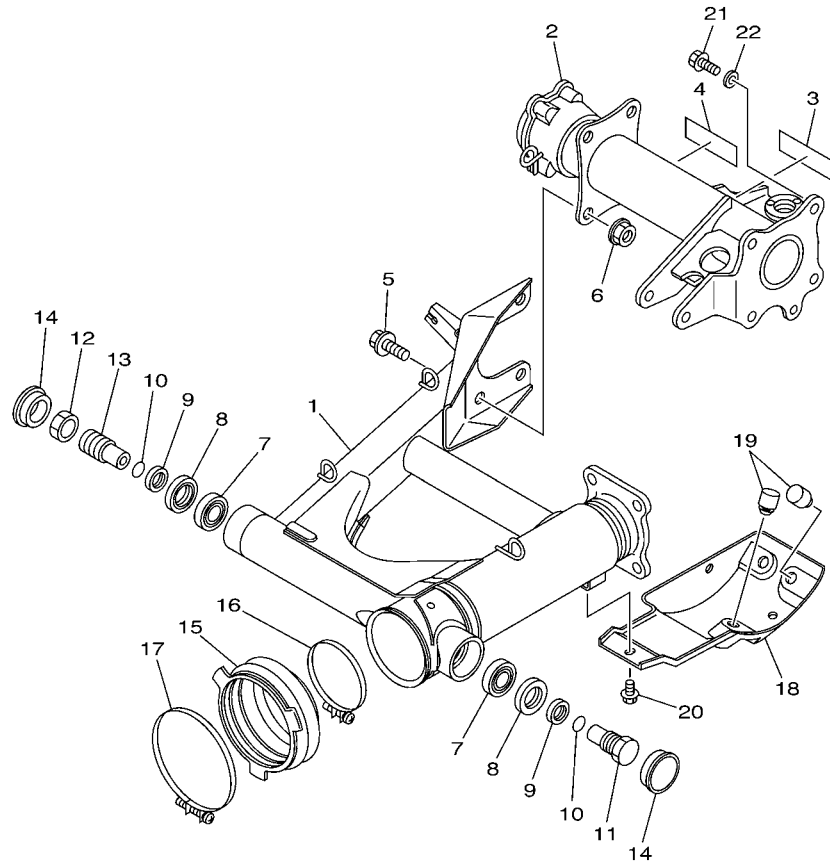

REF. NO.	PART NO.	DESCRIPTION	USA	CAN	REMARKS
1	4XE-F2110-20	REAR ARM COMP.	1	1	(YMUS)
2	1P0-G6540-00	REAR AXLE HOUSING COMP.	1	1	(YMUS)
3	4XE-F151K-00	LABEL 7	1	1	ENGLISH (YMUS)
4	4XE-F151K-10	LABEL 7		1	FRENCH (YMUS)
5	9581P-12025	BOLT, FLANGE	4	4	(YMUS)
6	95707-12500	NUT, FLANGE	4	4	
7	93332-000Y3	BEARING	2	2	(YMUS)
8	93102-25017	OIL SEAL	2	2	
9	90387-1711G	COLLAR	2	2	
10	93210-17718	O-RING	2	2	
11	4XE-F2141-00	SHAFT, PIVOT	1	1	(YMUS)
12	4XE-F2143-00	NUT	1	1	(YMUS)
13	4XE-F214H-00	SHAFT, PIVOT 2	1	1	(YMUS)
14	90338-34264	PLUG	2	2	
15	29U-22189-00	BOOT, RUBBER	1	1	
16	90460-85135	CLAMP, HOSE	1	1	
17	90460-99228	CLAMP, HOSE	1	1	
18	4XE-F219X-00	COVER	1	1	(YMUS)
19	109-27114-00	STOPPER, MAIN STAND	3	3	
20	95807-08012	BOLT, FLANGE	2	2	
21	90105-10893	BOLT, FLANGE	4	4	(YMUS)
22	90201-101J1	WASHER, PLATE	4	4	



4XEE100-2240

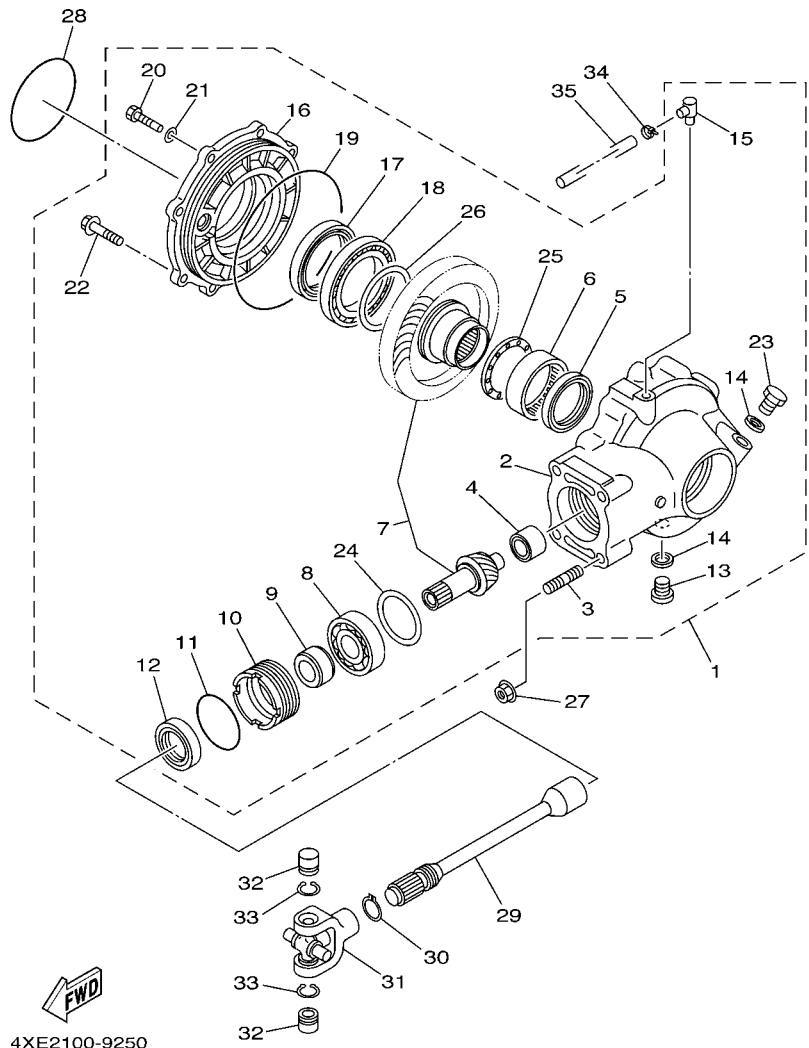
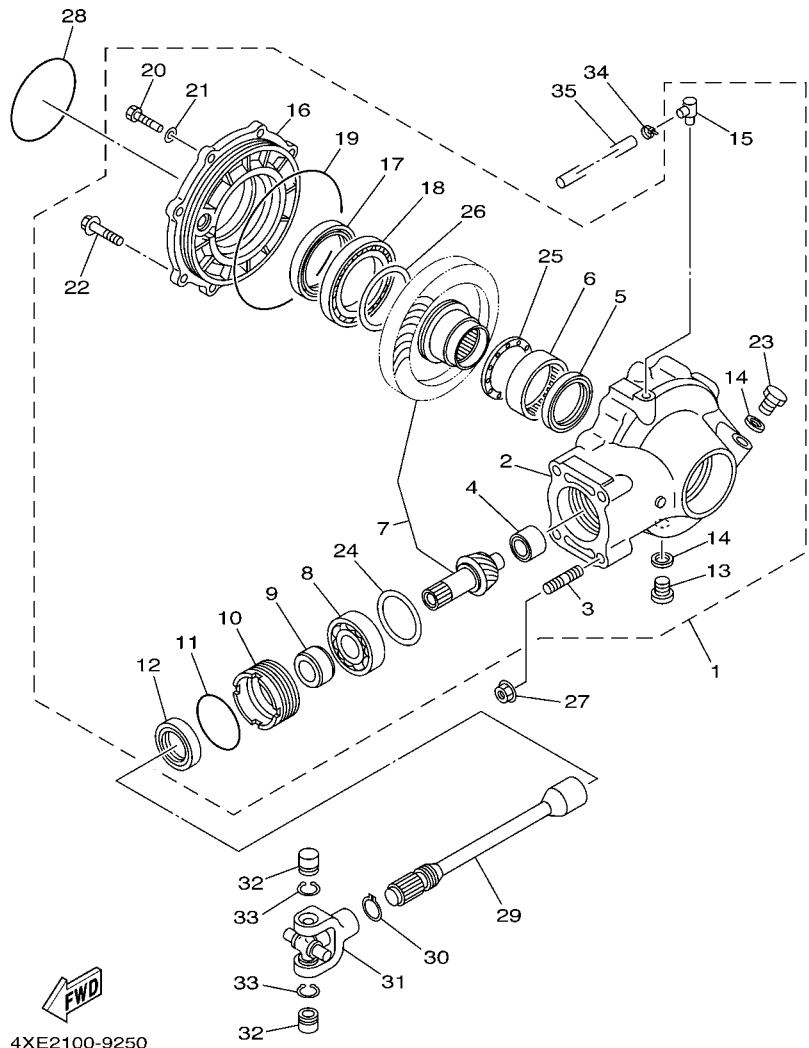

FIG. 25 DRIVE SHAFT

REF. NO.	PART NO.	DESCRIPTION	USA	CAN	REMARKS
1	4XE-G6101-01	REAR AXLE GEAR CASE ASSY	1	1	(YMUS)
2	4XE-G6151-01	.HOUSING, DRIVE SHAFT	1	1	(YMUS)
3	90116-10840	.BOLT, STUD	4	4	(YMUS)
4	4XE-G6102-00	.BEARING ASSY	1	1	(YMUS)
5	93101-52116	.OIL SEAL	1	1	
6	93317-855Y9	.BEARING	1	1	(YMUS)
7	4XE-Y4612-00	.RING GEAR SET	1	1	
8	93306-305Y6	.BEARING	1	1	(YMUS)
9	90387-255H9	.COLLAR	1	1	
10	29U-46125-00	.RETAINER, BEARING	1	1	
11	93210-59531	.O-RING	1	1	
12	93101-38098	.OIL SEAL	1	1	
13	90340-14046	.PLUG, STRAIGHT SCREW	1	1	
14	214-11198-01	.GASKET	2	2	
15	2N4-15371-00	.BREATHER	1	1	
16	4XE-G6152-01	.HOUSING, BEARING	1	1	(YMUS)
17	93102-65386	.OIL SEAL	1	1	
18	93316-013Y0	.BEARING	1	1	(YMUS)
19	93211-51749	.O-RING	1	1	
20	9702P-08025	.BOLT	6	6	(YMUS)
21	9290P-08600	.WASHER	6	6	(YMUS)
22	9581P-10045	.BOLT, FLANGE	2	2	(YMUS)
23	90340-14029	.PLUG, STRAIGHT SCREW	1	1	
24	4XE-E7537-15	.SHIM, THRUST(T=0.15MM)	1	1	UR (YMUS)
	4XE-E7537-30	.SHIM, THRUST(T=0.30MM)	1	1	UR (YMUS)
	4XE-E7537-40	.SHIM, THRUST(T=0.40MM)	1	1	UR (YMUS)
	4XE-E7537-45	.SHIM, THRUST(T=0.45MM)	1	1	UR (YMUS)



4XE2100-9250

FIG. 25 DRIVE SHAFT

REF. NO.	PART NO.	DESCRIPTION	USA	CAN	REMARKS
24	4XE-E7537-50	.SHIM, THRUST(T=0.50MM)	1	1	UR (YMUS)
	4XE-E7537-60	.SHIM, THRUST(T=0.60MM)	1	1	UR (YMUS)
25	4XE-G6118-10	.SHIM, THRUST(T=1.0MM)	1	1	UR (YMUS)
	4XE-G6118-11	.SHIM, THRUST(T=1.1MM)	1	1	UR (YMUS)
	4XE-G6118-12	.SHIM, THRUST(T=1.2MM)	1	1	UR (YMUS)
	4XE-G6118-13	.SHIM, THRUST(T=1.3MM)	1	1	UR (YMUS)
	4XE-G6118-14	.SHIM, THRUST(T=1.4MM)	1	1	UR (YMUS)
	4XE-G6118-15	.SHIM, THRUST(T=1.5MM)	1	1	UR (YMUS)
	4XE-G6118-16	.SHIM, THRUST(T=1.6MM)	1	1	UR (YMUS)
	4XE-G6118-17	.SHIM, THRUST(T=1.7MM)	1	1	UR (YMUS)
	4XE-G6118-18	.SHIM, THRUST(T=1.8MM)	1	1	UR (YMUS)
	4XE-G6118-19	.SHIM, THRUST(T=1.9MM)	1	1	UR (YMUS)
	4XE-G6118-20	.SHIM, THRUST(T=2.0MM)	1	1	UR (YMUS)
	4XE-G6118-21	.SHIM, THRUST(T=2.1MM)	1	1	UR (YMUS)
	4XE-G6118-A3	.SHIM, THRUST(T=1.35MM)	1	1	UR (YMUS)
	4XE-G6118-A4	.SHIM, THRUST(T=1.45MM)	1	1	UR (YMUS)
	4XE-G6118-A5	.SHIM, THRUST(T=1.55MM)	1	1	UR (YMUS)
26	4XE-G6117-25	.SHIM, RING GEAR(T=0.25MM)	1	1	UR (YMUS)
	4XE-G6117-30	.SHIM, RING GEAR(T=0.30MM)	1	1	UR (YMUS)
	4XE-G6117-35	.SHIM, RING GEAR(T=0.35MM)	1	1	UR (YMUS)
	4XE-G6117-40	.SHIM, RING GEAR(T=0.40MM)	1	1	UR (YMUS)
	4XE-G6117-45	.SHIM, RING GEAR(T=0.45MM)	1	1	UR (YMUS)
	4XE-G6117-50	.SHIM, RING GEAR(T=0.50MM)	1	1	UR (YMUS)
27	95707-10500	NUT, FLANGE	4	4	
28	93210-85706	O-RING	1	1	
29	4XE-G6172-00	SHAFT, DRIVE	1	1	(YMUS)
30	93410-22039	CIRCLIP	1	1	

D6

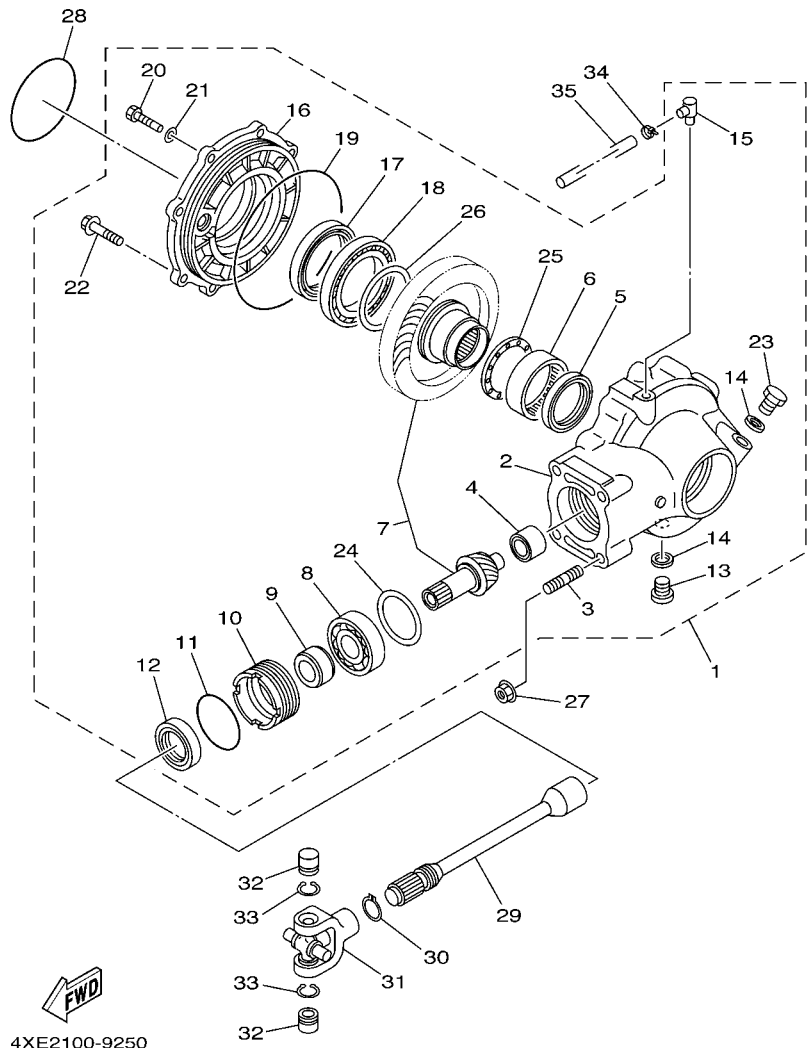
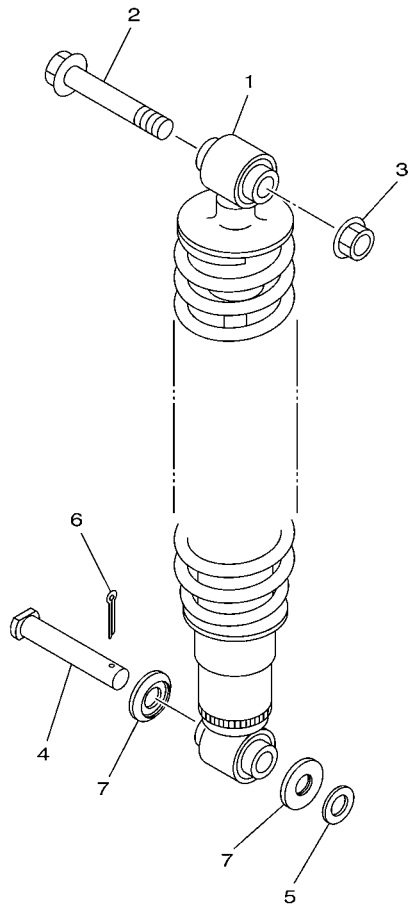

FIG. 25 DRIVE SHAFT

REF. NO.	PART NO.	DESCRIPTION	USA	CAN				REMARKS
31	4X7-46180-00	CROSS JOINT COMP.	1	1				
32	93311-21044	BEARING	2	2				
33	93440-20088	CIRCLIP	2	2				
34	90467-07029	CLIP	1	1				
35	90445-078C4	HOSE (L900)	1	1				(YMUS)

FIG. 26 REAR SUSPENSION



FWD
4XE2100-9260

REF. NO.	PART NO.	DESCRIPTION	USA	CAN				REMARKS
1	4XE-F2210-10	SHOCK ABSORBER ASSY, REAR	1	1				(YMUS)
2	90105-12889	BOLT, FLANGE	1	1				(YMUS)
3	90185-12072	NUT, SELF-LOCKING	1	1				
4	90240-12092	PIN, CLEVIS	1	1				
5	90201-127J6	WASHER, PLATE	1	1				
6	91401-30025	PIN, SPLIT	1	1				
7	1W1-22128-00	COVER, THRUST 1	2	2				

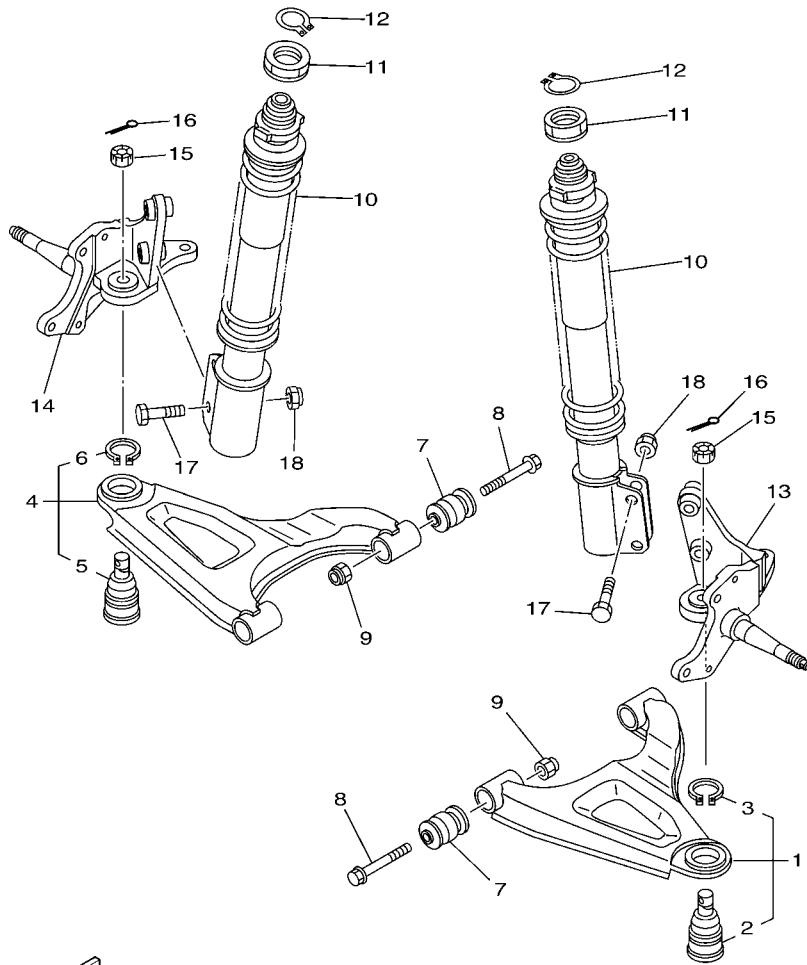



 4XE-H100-B270

FIG. 27 FRONT SUSPENSION & WHEEL

REF. NO.	PART NO.	DESCRIPTION	USA	CAN		REMARKS
1	4XE-F3570-10	FRONT LOWER ARM COMP. (LEFT)	1	1		(YMUS)
2	4XE-F3549-00	.BALL JOINT 1	1	1		(YMUS)
3	93410-32826	.CIRCLIP	1	1		
4	4XE-F3580-10	FRONT LOWER ARM COMP. (RIGHT)	1	1		(YMUS)
5	4XE-F3549-00	.BALL JOINT 1	1	1		(YMUS)
6	93410-32826	.CIRCLIP	1	1		
7	2HR-23526-00	BUSH	4	4		
8	90105-10890	BOLT, FLANGE	4	4		(YMUS)
9	90185-10844	NUT, SELF-LOCKING	4	4		(YMUS)
10	4XE-F3350-10	SHOCK ABSORBER ASSY	2	2		(YMUS)
11	90179-35625	NUT	2	2		
12	93410-32826	CIRCLIP	2	2		
13	4XE-F3501-20	STEERING KNUCKLE ASSY (LEFT)	1	1		(YMUS)
14	4XE-F3502-20	STEERING KNUCKLE ASSY (RIGHT)	1	1		(YMUS)
15	90171-12816	NUT, CASTLE	2	2		(YMUS)
16	91401-25020	PIN, COTTER	2	2		
17	90101-12882	BOLT	4	4		(YMUS)
18	9561P-12100	NUT	4	4		(YMUS)

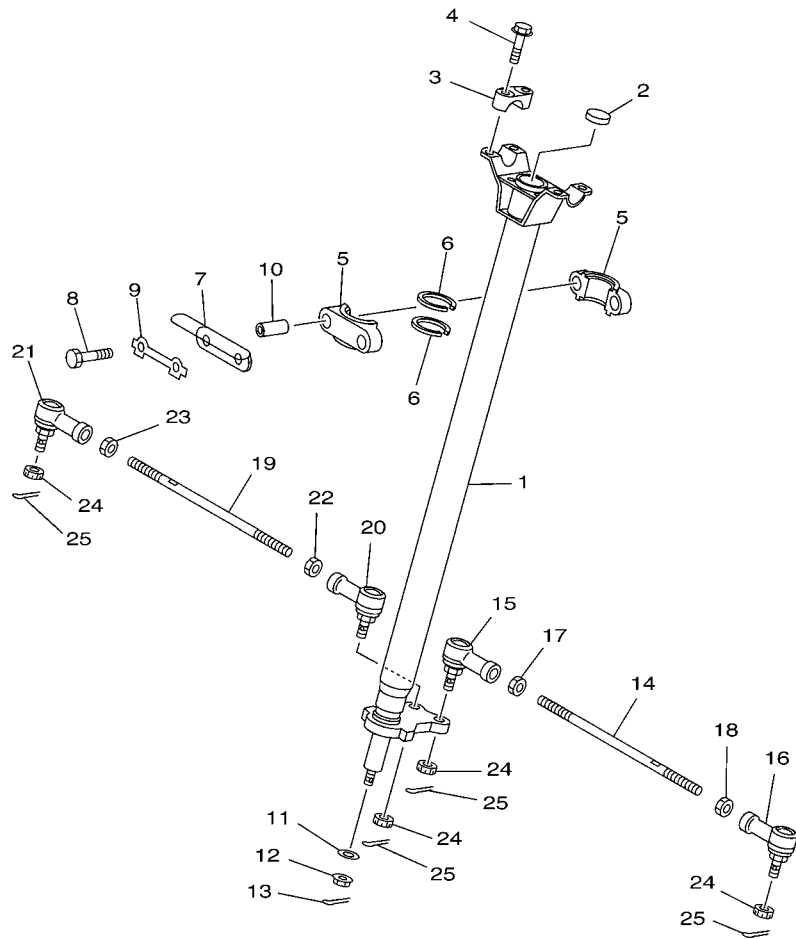
FIG. 28 STEERING



1P01100-D280

REF. NO.	PART NO.	DESCRIPTION	USA	CAN	REMARKS
1	1P0-F3813-00	COLUMN, STEERING 2	1	1	(YMUS)
2	90336-28053	PLUG, TAPER	1	1	
3	8K1-23814-00	HOLDER, HANDLE	2	2	
4	9581P-08030	BOLT, FLANGE	4	4	(YMUS)
5	1UY-23812-00	PLANE BEARING, STEERING	2	2	
6	93112-31011	OIL SEAL	2	2	
7	4XE-F3868-10	BRACKET, STEERING LOWER	1	1	(YMUS)
8	9702P-08060	BOLT	2	2	(YMUS)
9	4XE-F3894-00	WASHER, LOCK 1	1	1	(YMUS)
10	90387-090R0	COLLAR	2	2	
11	90201-108P8	WASHER, PLATE	1	1	(YMUS)
12	90185-10115	NUT, SELF-LOCKING	1	1	
13	91401-20025	PIN, COTTER	1	1	
14	4XE-F3831-00	ROD, TIE	1	1	(YMUS)
15	5FU-F3841-00	JOINT, UNIVERSAL 1	1	1	(YMUS)
16	5FU-F3845-00	JOINT, UNIVERSAL 2	1	1	(YMUS)
17	4XE-F3833-00	NUT 1	1	1	(YMUS)
18	4XE-F3834-00	NUT 2	1	1	(YMUS)
19	4XE-F3831-00	ROD, TIE	1	1	(YMUS)
20	5FU-F3841-00	JOINT, UNIVERSAL 1	1	1	(YMUS)
21	5FU-F3845-00	JOINT, UNIVERSAL 2	1	1	(YMUS)
22	4XE-F3833-00	NUT 1	1	1	(YMUS)
23	4XE-F3834-00	NUT 2	1	1	(YMUS)
24	90171-12816	NUT, CASTLE	4	4	(YMUS)
25	91401-25020	PIN, COTTER	4	4	

FIG. 29 FUEL TANK

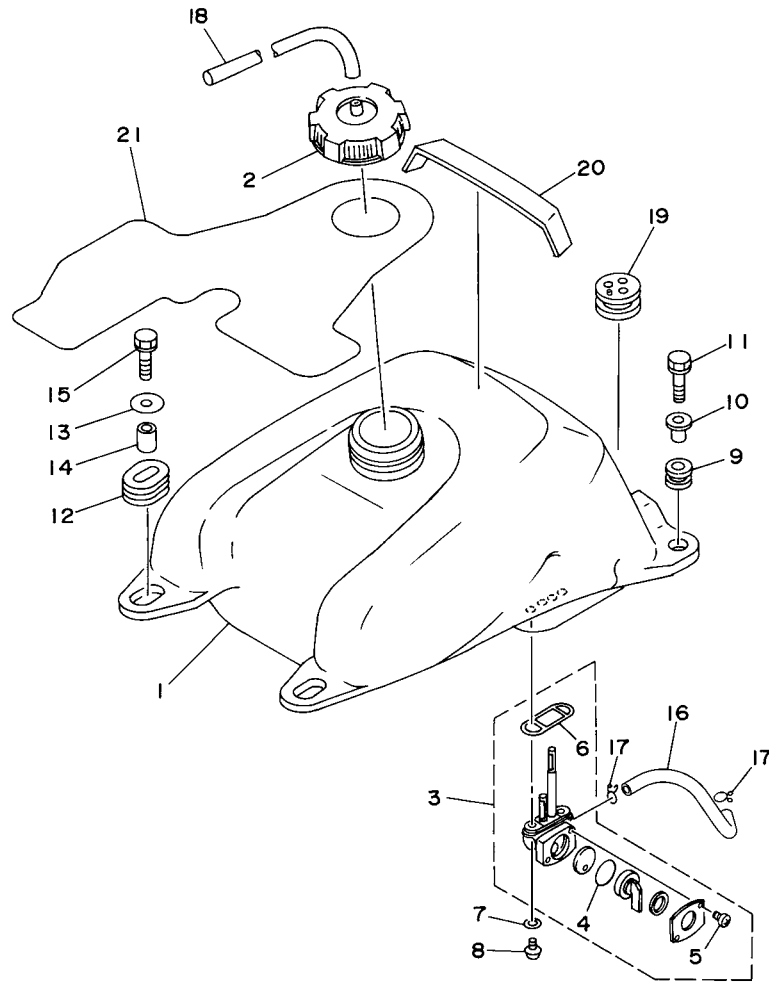

REF. NO.	PART NO.	DESCRIPTION	USA	CAN	REMARKS
1	4XE-F4110-00	FUEL TANK COMP.	1	1	(YMUS)
2	5KM-24610-00	CAP ASSY	1	1	
3	3JN-24500-02	FUEL COCK ASSY 1	1	1	
4	3AJ-24534-01	.SEAL, COCK	1	1	
5	98507-03008	.SCREW, PAN HEAD	2	2	
6	4X8-24512-00	.O-RING	1	1	
7	90202-05193	WASHER, PLATE	2	2	
8	90149-06011	SCREW	2	2	
9	90480-18290	GROMMET	2	2	
10	90387-066J1	COLLAR	2	2	
11	90119-06831	BOLT, WITH WASHER	2	2	(YMUS)
12	90480-01400	GROMMET	2	2	
13	90201-060L5	WASHER, PLATE	2	2	
14	90387-07598	COLLAR	2	2	
15	90119-06831	BOLT, WITH WASHER	2	2	(YMUS)
16	1P0-24311-00	PIPE, FUEL 1	1	1	
17	90467-10008	CLIP	2	2	
18	90445-08809	HOSE (L500)	1	1	(YMUS)
19	4BD-24339-00	GROMMET	1	1	
20	4XE-F4181-00	DAMPER, LOCATING 1	1	1	(YMUS)
21	4XE-F414H-00	DAMPER, PLATE 1	1	1	(YMUS)



1P01100-D290

FIG. 30 SEAT

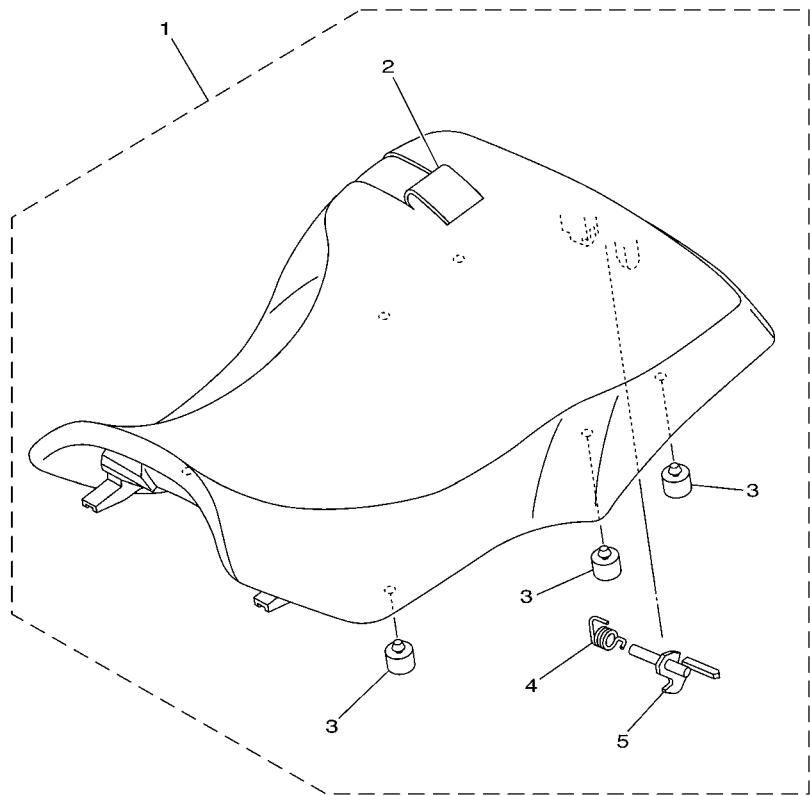

REF. NO.	PART NO.	DESCRIPTION	USA	CAN				REMARKS
1	5UH-F4710-00	SINGLE SEAT ASSY	1	1				(YMUS)
2	5UH-F470F-00	.SEAT COVER COMP.	1	1				(YMUS)
3	5UH-F4747-00	.DAMPER, SEAT	6	6				(YMUS)
4	5UH-F478V-00	.SPRING, TORSION	1	1				(YMUS)
5	5UH-F4776-00	.LEVER, SEAT	1	1				(YMUS)

5ND1100-3320

FIG. 31 FRONT WHEEL

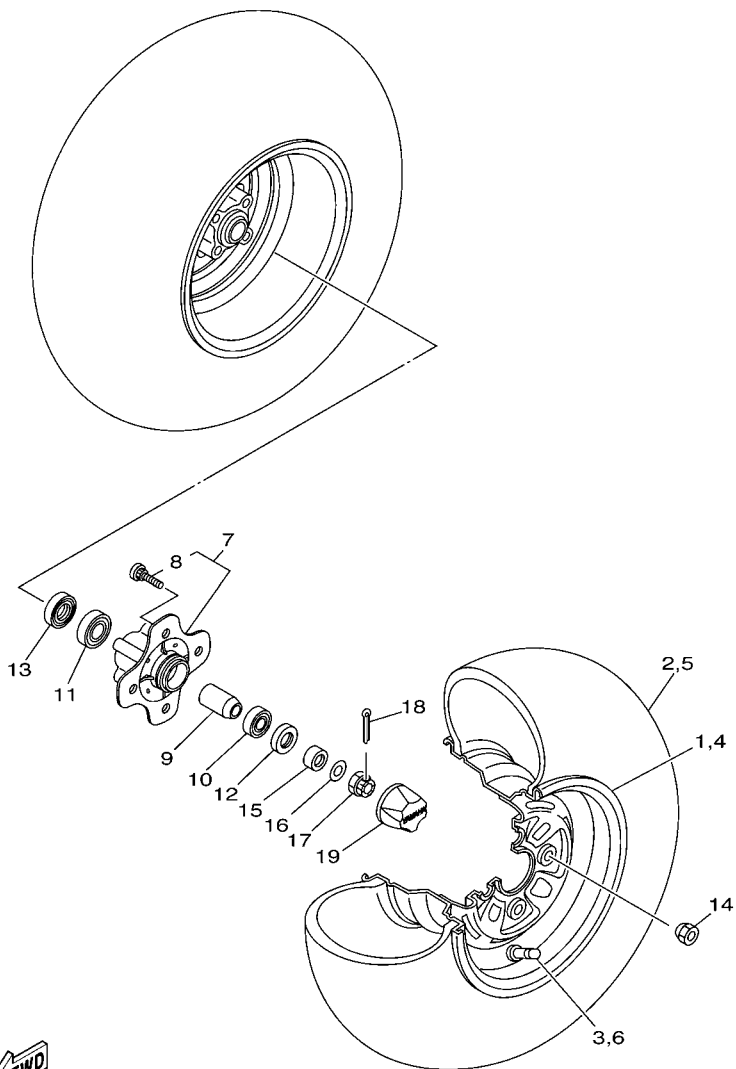

4XEE100-2310

REF. NO.	PART NO.	DESCRIPTION	USA	CAN		REMARKS
1	4XE-F5180-31	WHEEL COMP.	1	1		(YMUS)
2	94107-10800	TIRE (AT 22X 7-10, M-905)	1	1		CHENG SHIN
3	93900-00813	VALVE, RIM (TR413)	1	1		CHENG SHIN
4	4XE-F5180-31	WHEEL COMP.	1	1		(YMUS)
5	94107-10800	TIRE (AT 22X 7-10, M-905)	1	1		CHENG SHIN
6	93900-00813	VALVE, RIM (TR413)	1	1		CHENG SHIN
7	4XE-F5111-20	HUB, FRONT	2	2		(YMUS)
8	90114-10804	.BOLT, SERRATION	4	4		(YMUS)
9	1UY-25117-00	SPACER, BEARING	2	2		
10	93306-004YX	BEARING	2	2		(YMUS)
11	93306-202XM	BEARING	2	2		(YMUS)
12	93102-22216	OIL SEAL	2	2		
13	93105-26026	OIL SEAL	2	2		
14	90179-10540	NUT	8	8		
15	90387-150R1	COLLAR	2	2		
16	90201-148R0	WASHER, PLATE	2	2		(YMUS)
17	90171-14817	NUT, CASTLE	2	2		(YMUS)
18	91401-30025	PIN, SPLIT	2	2		
19	52H-2512A-00	CAP, WHEEL	2	2		

FIG. 32 FRONT BRAKE CALIPER

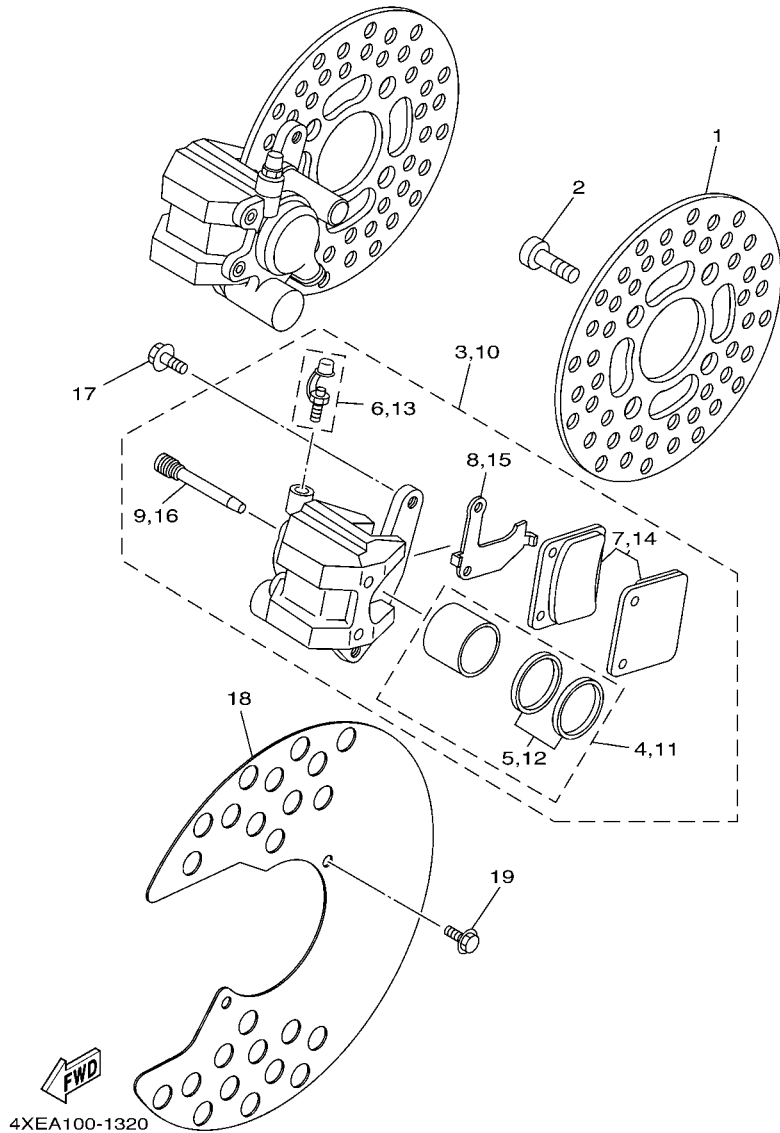

REF. NO.	PART NO.	DESCRIPTION	USA	CAN	REMARKS
1	4XE-F582T-10	DISC, BRAKE (LEFT)	2	2	(YMUS)
2	90149-08268	SCREW	8	8	
3	3GD-2580T-00	CALIPER ASSY (LEFT)	1	1	
4	3GD-W0057-00	.PISTON ASSY, CALIPER	1	1	
5	3GD-W0047-00	..CALIPER SEAL KIT	1	1	
6	1UY-W0048-50	.BLEED SCREW KIT	1	1	
7	3GD-W0045-00	.BRAKE PAD KIT	1	1	
8	3GD-25827-00	.SHIM, CALIPER	1	1	
9	3GD-25933-00	.PIN, PAD	2	2	
10	3GD-2580U-00	CALIPER ASSY (RIGHT)	1	1	
11	3GD-W0057-00	.PISTON ASSY, CALIPER	1	1	
12	3GD-W0047-00	..CALIPER SEAL KIT	1	1	
13	1UY-W0048-50	.BLEED SCREW KIT	1	1	
14	3GD-W0045-00	.BRAKE PAD KIT	1	1	
15	3GD-25828-00	.SHIM, CALIPER	1	1	
16	3GD-25933-00	.PIN, PAD	2	2	
17	90105-088B2	BOLT, FLANGE	4	4	(YMUS)
18	4XE-F514A-00	RING, WHEEL 1 (LEFT)	2	2	(YMUS)
19	9582P-06012	BOLT, FLANGE	4	4	(YMUS)

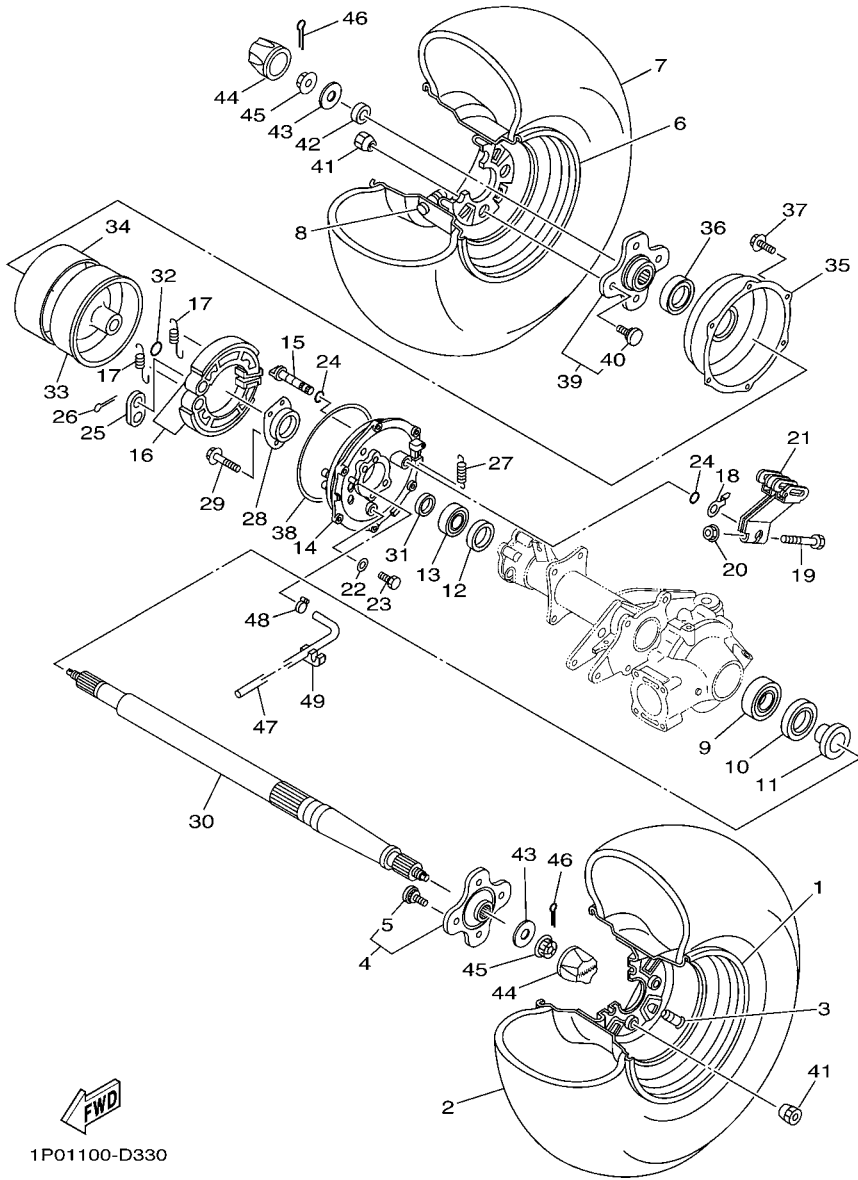
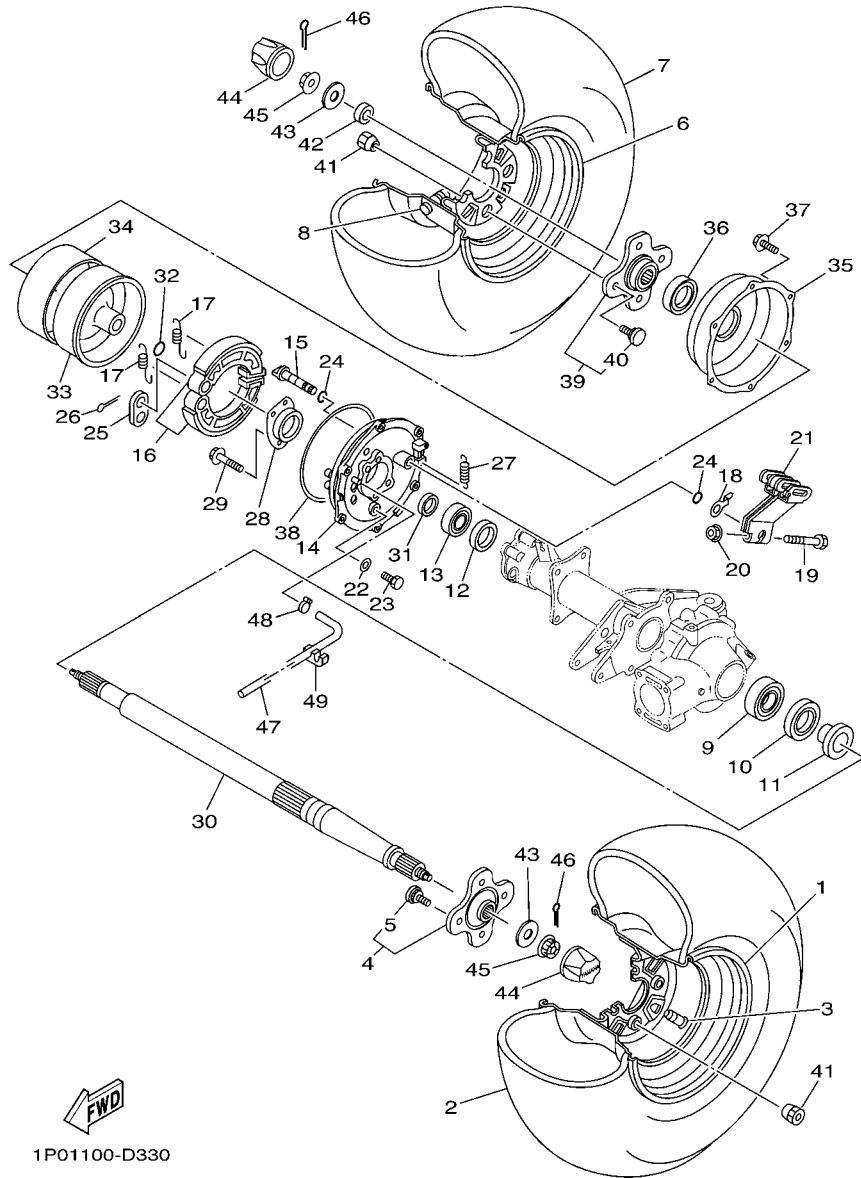

FIG. 33 REAR WHEEL

REF. NO.	PART NO.	DESCRIPTION	USA	CAN	REMARKS
1	4XE-F5390-31	REAR WHEEL COMP.	1	1	(YMUS)
2	94110-10800	TIRE (AT 22X10-10, M-906)	1	1	CHENG SHIN
3	93900-00810	VALVE, RIM (TR413)	1	1	DUNLOP
4	5ND-F5383-00	COLLAR, WHEEL	1	1	UR (YMUS)
	5ND-F5383-10	COLLAR, WHEEL	1	1	UR (YMUS)
5	90114-10804	BOLT, SERRATION	4	4	(YMUS)
6	4XE-F5390-31	REAR WHEEL COMP.	1	1	(YMUS)
7	94110-10800	TIRE (AT 22X10-10, M-906)	1	1	CHENG SHIN
8	93900-00810	VALVE, RIM (TR413)	1	1	DUNLOP
9	93306-008Y0	BEARING	1	1	(YMUS)
10	93106-47040	OIL SEAL	1	1	
11	4SH-25367-01	COVER, HUB DUST	1	1	
12	93101-35097	OIL SEAL	1	1	
13	93306-278Y0	BEARING	1	1	(YMUS)
14	5VH-F5321-10	PLATE, BRAKE SHOE	1	1	(YMUS)
15	5VH-F5351-00	CAMSHAFT	1	1	(YMUS)
16	5VH-WF536-00	BRAKE SHOE SET	1	1	(YMUS)
17	5VH-F5333-00	SPRING, RETURN	2	2	(YMUS)
18	5FU-F533A-10	PLATE, INDICATOR	1	1	(YMUS)
19	5VH-F5833-00	BOLT, FITTING	1	1	(YMUS)
20	9560L-06200	NUT, SELF-LOCKING	1	1	(YMUS)
21	1P0-F5355-00	LEVER, CAMSHAFT	1	1	(YMUS)
22	5VH-F5898-00	GASKET	1	1	(YMUS)
23	5VH-F5818-00	BOLT, CALIPER	1	1	(YMUS)
24	5VH-F5359-00	SEAL, CAMSHAFT	2	2	(YMUS)
25	5VH-F539F-00	PLATE 1	1	1	(YMUS)
26	91401-25020	PIN, COTTER	2	2	



1P01100-D330

FIG. 33 REAR WHEEL

REF. NO.	PART NO.	DESCRIPTION	USA	CAN	REMARKS
27	90506-16482	SPRING, TENSION	1	1	
28	4XE-G6513-00	RETAINER	1	1	(YMUS)
29	90105-08892	BOLT, FLANGE	4	4	(YMUS)
30	1P0-F5381-00	AXLE, WHEEL	1	1	(YMUS)
31	90387-284T0	COLLAR	1	1	
32	93210-26606	O-RING	1	1	
33	5FU-F531E-10	DRUM, BRAKE	1	1	(YMUS)
34	5FU-F5336-00	RING 2	1	1	(YMUS)
35	5FU-F5327-00	COVER, PLATE	1	1	(YMUS)
36	5FU-F5319-00	SEAL, HUB DUST	1	1	(YMUS)
37	9582P-06012	BOLT, FLANGE	6	6	(YMUS)
38	5FU-F537Y-00	SEAL, DUST	1	1	(YMUS)
39	5FU-F5377-10	COLLAR, WHEEL	1	1	(YMUS)
40	90114-10804	.BOLT, SERRATION	4	4	(YMUS)
41	90179-10540	NUT	8	8	
42	5FU-F5384-00	WASHER, WHEEL	1	1	(YMUS)
43	90201-168R1	WASHER, PLATE	2	2	(YMUS)
44	52H-2512A-00	CAP, WHEEL	2	2	
45	90171-16001	NUT, CASTLE	2	2	
46	91401-30030	PIN, COTTER	2	2	
47	90445-07810	HOSE (L1050)	1	1	(YMUS)
48	90467-07093	CLIP	1	1	
49	90468-15020	CLIP	2	2	

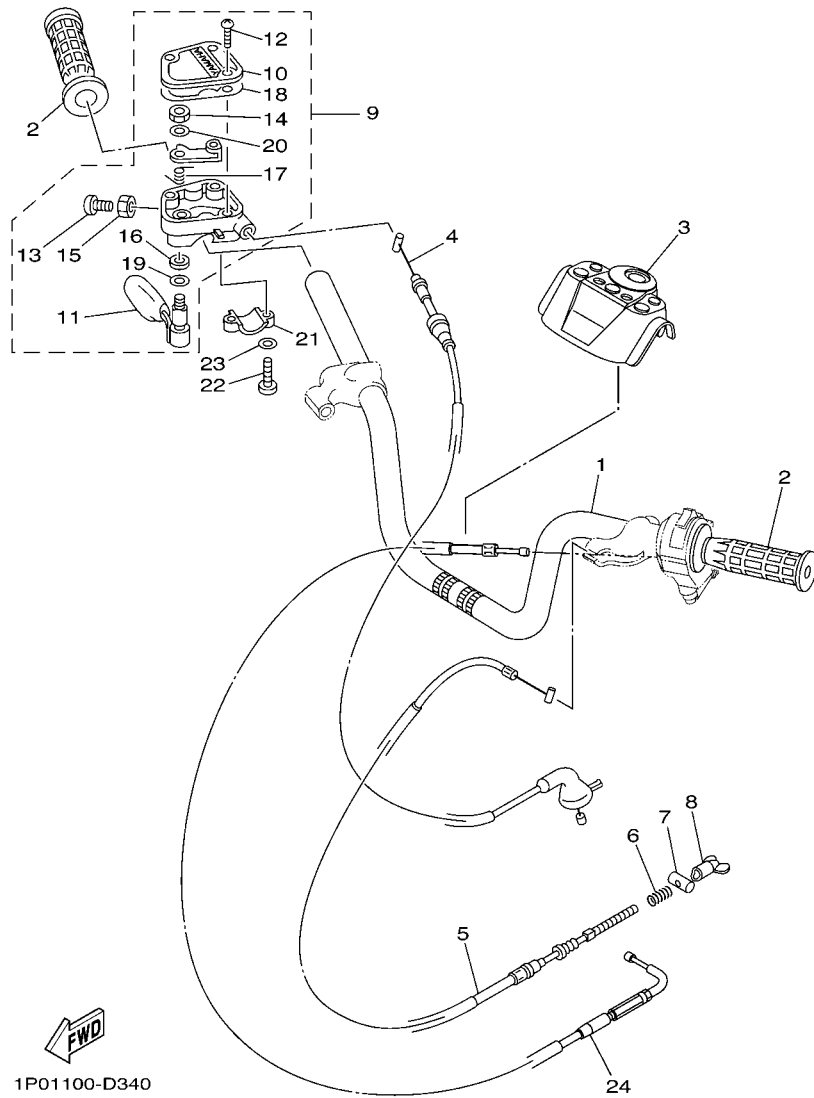
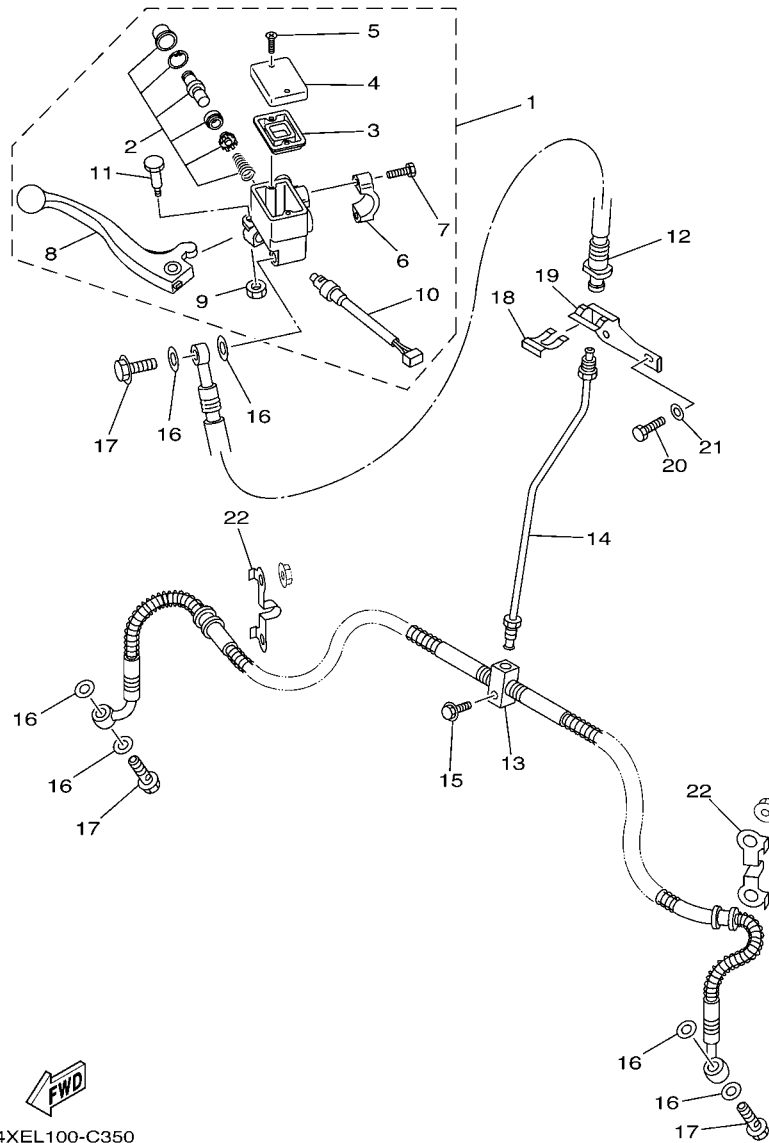

FIG. 34 STEERING HANDLE & CABLE

REF. NO.	PART NO.	DESCRIPTION	USA	CAN	REMARKS
1	5FU-F6111-10	HANDLEBAR	1	1	(YMUS)
2	5FU-F6241-10	GRIP	2	2	(YMUS)
3	1P0-F6124-00	PROTECTOR, HANDLEBAR	1	1	(YMUS)
4	1P0-26311-00	CABLE, THROTTLE 1	1	1	
5	1P0-26341-00	CABLE, BRAKE	1	1	
6	90501-10782	SPRING, COMPRESSION	1	1	
7	90249-12008	PIN	1	1	
8	20E-26343-00	NUT, ADJUSTING	1	1	
9	4KB-26250-10	THROTTLE LEVER ASSY	1	1	
10	4KB-2628F-10	.CAP, GEAR	1	1	
11	1NV-2625G-01	.LEVER, THROTTLE	1	1	
12	90149-04278	.SCREW	3	3	
13	98507-05020	.SCREW, PAN HEAD	1	1	
14	95607-05100	.NUT, U	1	1	
15	95307-05700	.NUT	1	1	
16	93104-09025	.OIL SEAL	1	1	
17	1NV-26304-00	.SPRING	1	1	
18	4KB-2628G-00	.GASKET	1	1	
19	1NV-26129-00	.WASHER	1	1	
20	1NV-26398-00	.WASHER	1	1	
21	4V4-82913-00	HOLDER, LEVER LOWER 1	1	1	
22	98507-05020	SCREW, PAN HEAD	2	2	
23	92907-05600	WASHER, PLATE	2	2	
24	1P0-F6331-00	CABLE, STARTER 1	1	1	(YMUS)



4XEL100-C350

FIG. 35 FRONT MASTER CYLINDER

REF. NO.	PART NO.	DESCRIPTION	USA	CAN	REMARKS
1	5KM-2583T-01	MASTER CYLINDER ASSY	1	1	
2	8CR-W0041-00	.CYLINDER KIT, MASTER	1	1	
3	4L0-25854-00	.DIAPHRAGM, RESERVOIR	1	1	
4	5JX-25852-01	.CAP, RESERVOIR	1	1	
5	98706-04012	.SCREW, FLAT HEAD	2	2	
6	5GH-25867-00	.BRACKET, MASTER CYLINDER	1	1	
7	5EB-26332-00	.BOLT	2	2	
8	5KM-83922-00	.LEVER 2	1	1	
9	95606-06100	.NUT, U	1	1	
10	5LP-83980-00	.FRONT STOP SWITCH ASSY	1	1	
11	1FK-2589F-00	.BOLT, LEVER	1	1	
12	4XE-F5872-00	HOSE, BRAKE 1	1	1	(YMUS)
13	4XE-F5873-00	HOSE, BRAKE 2	1	1	(YMUS)
14	4XE-F5871-00	PIPE, BRAKE	1	1	(YMUS)
15	95807-06025	BOLT, FLANGE	1	1	
16	90201-10118	WASHER, PLATE	6	6	
17	90401-10159	BOLT, UNION	3	3	
18	2GU-25866-00	CIRCLIP	1	1	
19	4XE-F612K-10	BRACKET 2	1	1	(YMUS)
20	97007-06016	BOLT	2	2	
21	92907-06600	WASHER, PLATE	2	2	
22	4XE-F587A-00	HOLDER, BREAK HOSE	2	2	(YMUS)

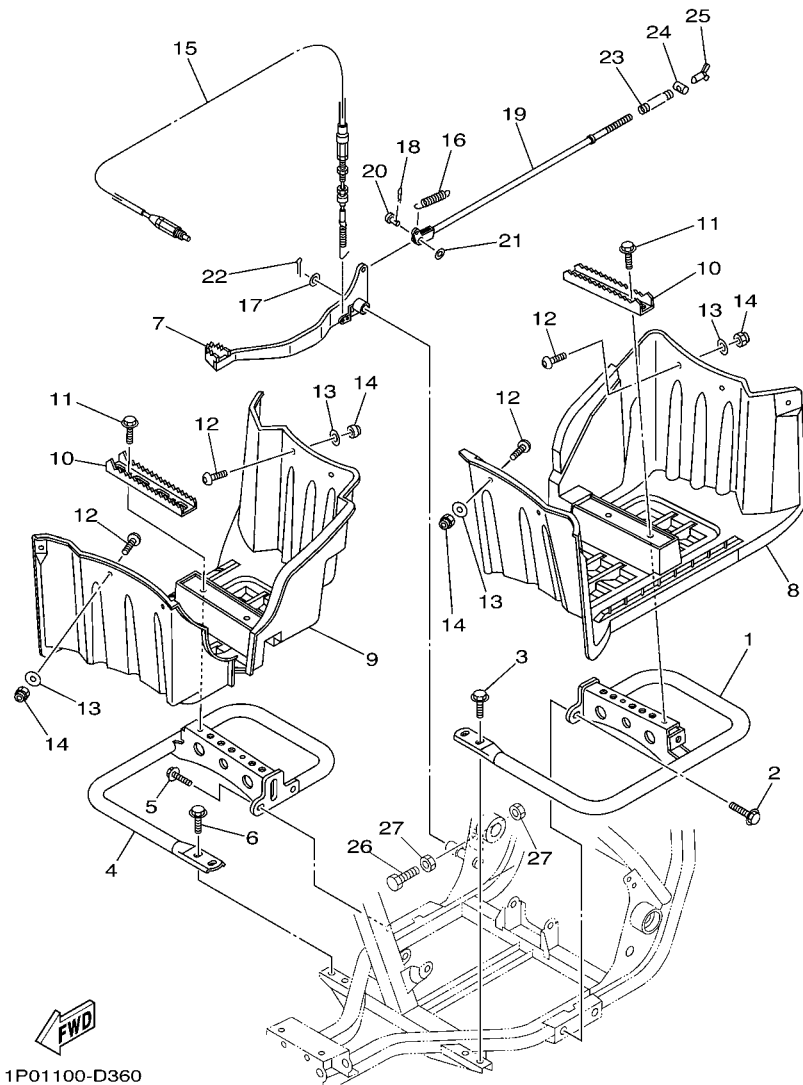

FIG. 36 STAND & FOOTREST

REF. NO.	PART NO.	DESCRIPTION	USA	CAN	REMARKS
1	1P0-F7452-00	BRACKET, FOOTREST 1	1	1	(YMUS)
2	9581P-10020	BOLT, FLANGE	2	2	(YMUS)
3	9581P-08016	BOLT, FLANGE	2	2	(YMUS)
4	1P0-F7462-00	BRACKET, FOOTREST 2	1	1	(YMUS)
5	9581P-10020	BOLT, FLANGE	2	2	(YMUS)
6	9581P-08016	BOLT, FLANGE	2	2	(YMUS)
7	1P0-F7211-00	PEDAL, BRAKE	1	1	(YMUS)
8	1P0-F7453-00	COVER 1	1	1	(YMUS)
9	1P0-F7463-00	COVER 2	1	1	(YMUS)
10	1P0-F741A-00	ARM 1	2	2	(YMUS)
11	9581P-06016	BOLT, FLANGE	4	4	(YMUS)
12	90149-05299	SCREW	12	12	
13	90201-05029	WASHER, PLATE	12	12	
14	95707-05300	NUT, FLANGE	12	12	
15	1P0-2637F-00	CABLE, CONTROL 2	1	1	
16	90506-18224	SPRING, TENSION	1	1	
17	90201-15797	WASHER, PLATE	1	1	
18	91401-40030	PIN, COTTER	1	1	
19	4XE-27231-00	ROD, BRAKE	1	1	
20	90240-06076	PIN, CLEVIS	1	1	
21	92907-06200	WASHER	1	1	
22	91401-20012	PIN, COTTER	1	1	
23	90501-10245	SPRING, COMPRESSION	1	1	
24	90249-12008	PIN	1	1	
25	20E-26343-00	NUT, ADJUSTING	1	1	
26	97017-06020	BOLT	1	1	
27	95317-06700	NUT	2	2	

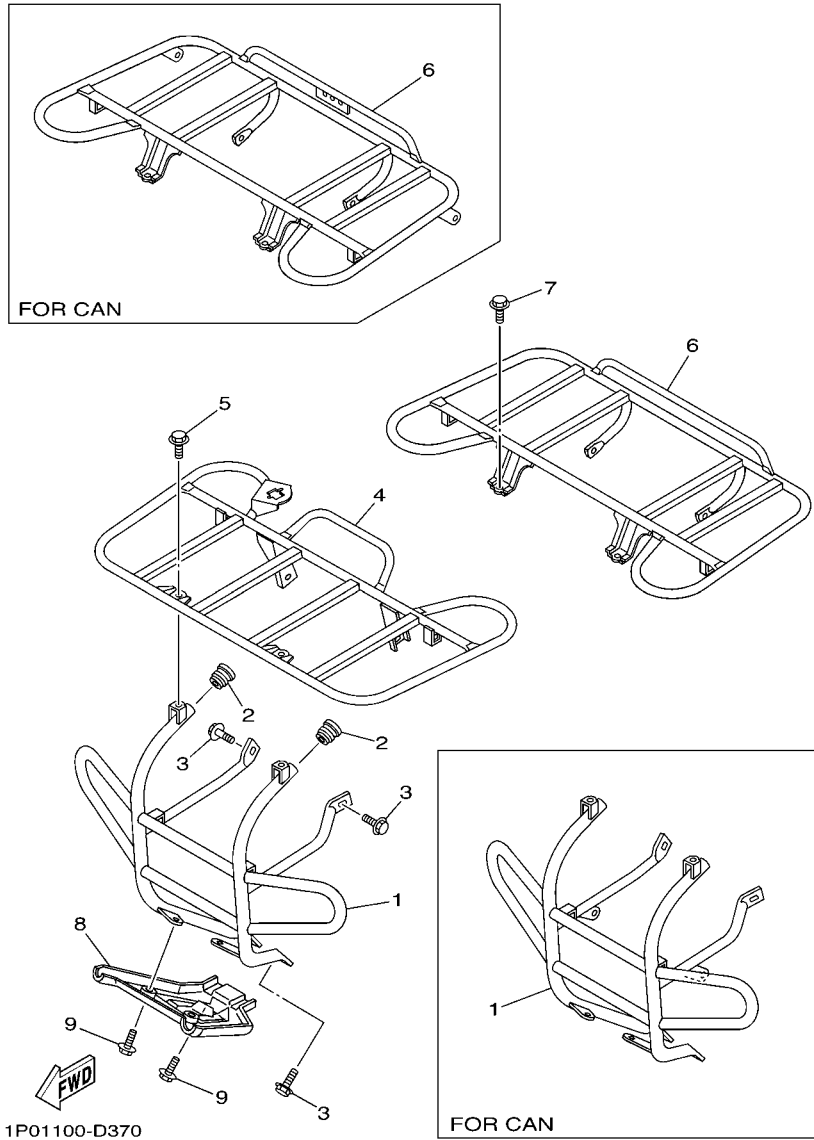
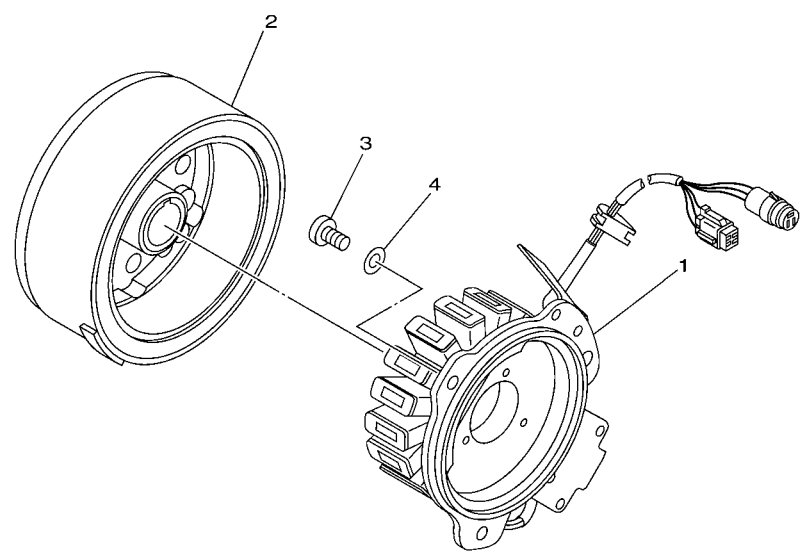

FIG. 37 GUARD

REF. NO.	PART NO.	DESCRIPTION	USA	CAN	REMARKS
1	1P0-F845N-00	BAR, CARRY FRONT	1		(YMUS)
	1P0-F845N-10	BAR, CARRY FRONT		1	(YMUS)
2	4XE-F1399-00	CAP, TOOL BOX	2	2	(YMUS)
3	9581P-08016	BOLT, FLANGE	6	6	(YMUS)
4	1P0-F4841-00	CARRIER, FRONT	1	1	(YMUS)
5	9581P-08012	BOLT, FLANGE	2	2	(YMUS)
6	1P0-F4842-00	CARRIER, REAR	1		(YMUS)
	1P0-F4842-10	CARRIER, REAR		1	(YMUS)
7	9581P-08016	BOLT, FLANGE	4	4	(YMUS)
8	1P0-F842M-00	COVER 1	1	1	(YMUS)
9	90109-063F1	BOLT	3	3	

FIG. 38 GENERATOR

REF. NO.	PART NO.	DESCRIPTION	USA	CAN				REMARKS
1	1P0-H1410-00	STATOR ASSY	1	1				(YMUS)
2	1P0-H1450-00	ROTOR ASSY	1	1				(YMUS)
3	98507-06016	SCREW, PAN HEAD	3	3				
4	92907-06600	WASHER, PLATE	3	3				



 1P01100-D380

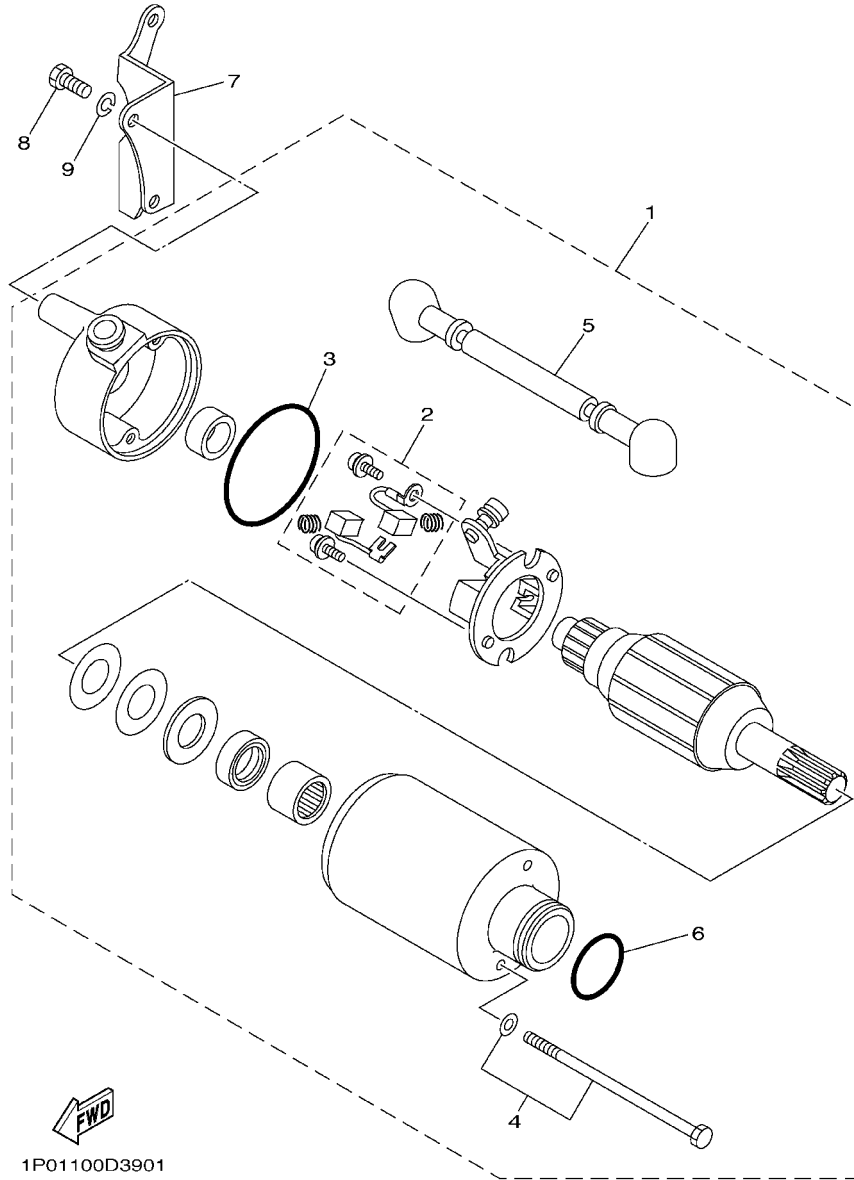

1P01100D3901

FIG. 39 STARTING MOTOR

REF. NO.	PART NO.	DESCRIPTION	USA	CAN	REMARKS
1	5XG-H1800-00	STARTING MOTOR ASSY	1	1	(YMUS)
2	3KW-H1801-00	.BRUSH SET	1	1	(YMUS)
3	93210-55669	.O-RING	1	1	
4	3KW-H1828-00	.BOLT 2	2	2	(YMUS)
5	5XG-H183G-00	.CORD COMP.	1	1	(YMUS)
6	93210-25711	.O-RING	1	1	
7	1EV-81823-00	STAY, STARTING MOTOR	1	1	
8	98507-06016	SCREW, PAN HEAD	2	2	
9	92907-06100	WASHER, SPRING	2	2	

FIG. 40 HEADLIGHT

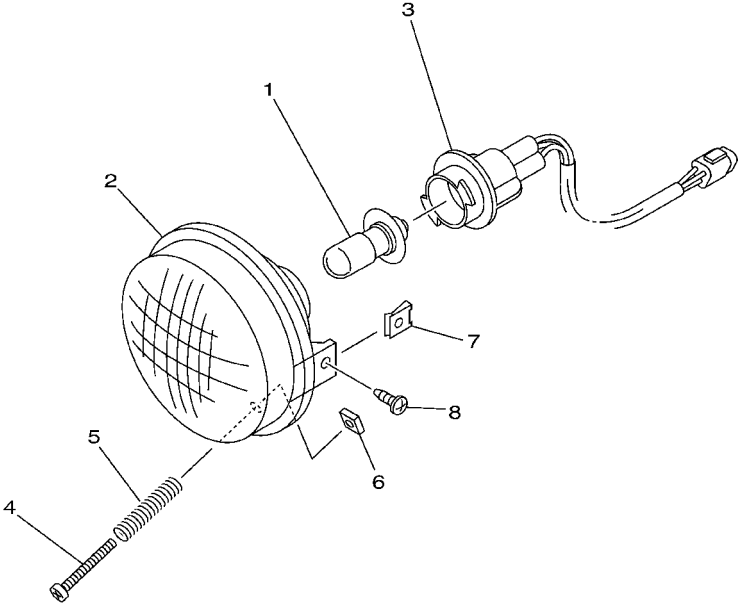

REF. NO.	PART NO.	DESCRIPTION	USA	CAN	REMARKS
1	5FU-H4314-00	BULB, HEADLIGHT (12V-30/30W)	2	2	(YMUS)
2	5FU-H4320-00	LENS ASSY	2	2	(YMUS)
3	5FU-H4340-00	SOCKET CORD ASSY 1	2	2	(YMUS)
4	98507-03540	SCREW, PAN HEAD	2	2	
5	2GU-84332-00	SPRING, SCREW	2	2	
6	2GU-84334-00	NUT, ADJUSTING	2	2	
7	90183-05008	NUT, SPRING	4	4	
8	90150-05802	SCREW, ROUND HEAD	4	4	(YMUS)

 1D91100D4501

FIG. 41 TAILLIGHT

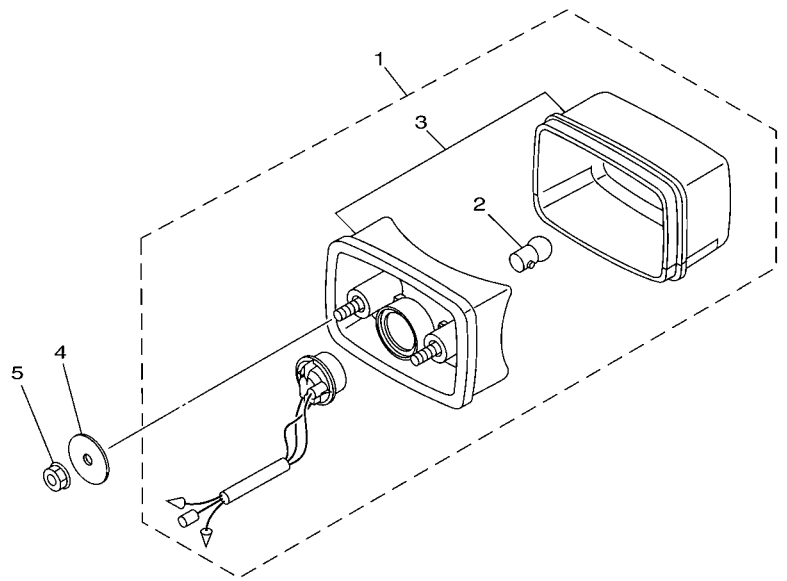

REF. NO.	PART NO.	DESCRIPTION	USA	CAN				REMARKS
1	5KM-84710-00	TAILLIGHT UNIT ASSY	1					
2	1A2-84714-41	.BULB (12V-21/5W)	1					
3	5KM-8472C-10	.LENS, TAILLIGHT	1					
4	90201-06074	WASHER, PLATE	2					
5	95707-06300	NUT, FLANGE	2					

 5ND1100-3460

FIG. 42 TAILLIGHT 2

REF. NO.	PART NO.	DESCRIPTION	USA	CAN				REMARKS
1	5KM-84710-00	TAILLIGHT UNIT ASSY		1				
2	1A2-84714-41	.BULB (12V-21/5W)		1				
3	5KM-8472C-10	.LENS, TAILLIGHT		1				
4	90201-06074	WASHER, PLATE		2				
5	95707-06300	NUT, FLANGE		2				
6	5GH-84751-10	BRACKET, LICENSE		1				

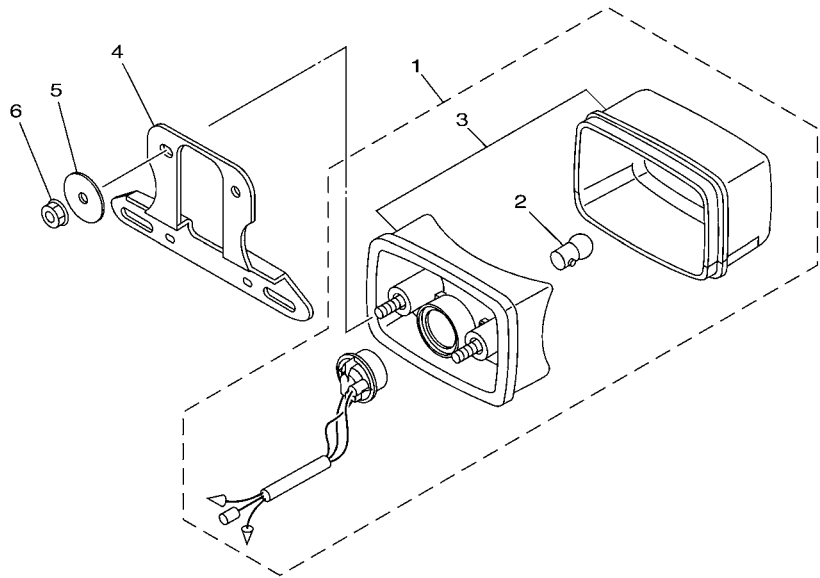

5ND1100-3470

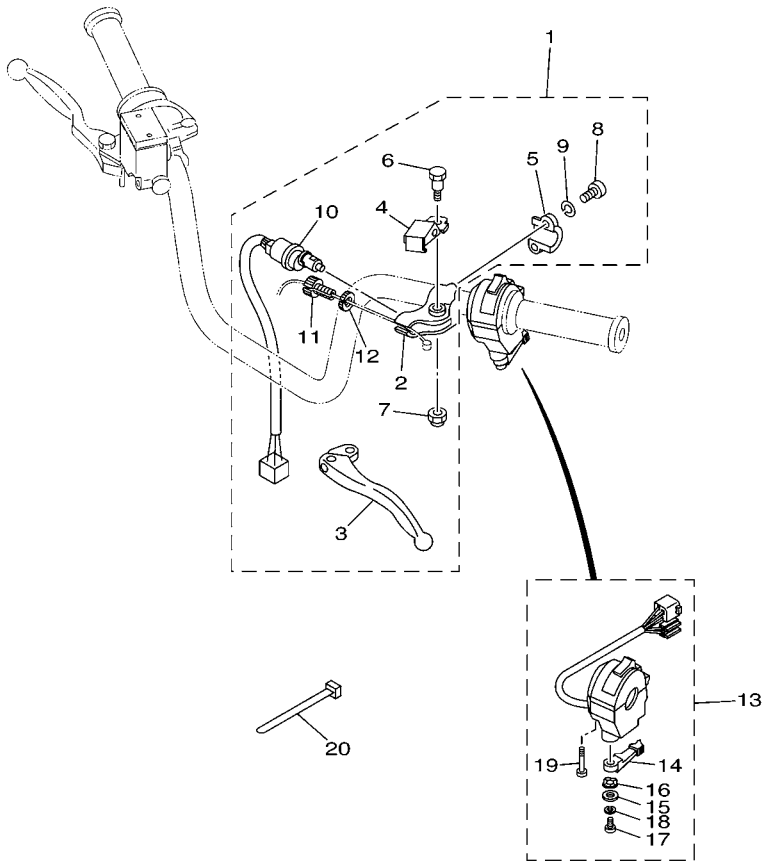

FIG. 43 HANDLE SWITCH & LEVER

REF. NO.	PART NO.	DESCRIPTION	USA	CAN	REMARKS
1	5FU-82910-23	LEVER HOLDER ASSY (LEFT)	1	1	
2	1YW-82911-02	.HOLDER, LEVER 1	1	1	
3	2HT-83912-00	.LEVER 1	1	1	
4	1YW-83965-00	.LEVER, LOCK	1	1	
5	2XJ-82913-00	.HOLDER, LEVER LOWER 1	1	1	
6	90109-06576	.BOLT	1	1	
7	95607-06100	.NUT, U	1	1	
8	98507-06020	.SCREW, PAN HEAD	2	2	
9	92907-06100	.WASHER, SPRING	2	2	
10	3FA-83980-03	.FRONT STOP SWITCH ASSY	1	1	
11	90123-08046	.BOLT	1	1	
12	90179-08148	.NUT	1	1	
13	5LP-83973-01	SWITCH, HANDLE 3	1	1	
14	5GH-83941-00	.LEVER, STARTER	1	1	
15	1UY-83909-00	.WASHER, SPECIAL	1	1	
16	3L4-83943-00	.WASHER, STARTER	1	1	
17	98517-05012	.SCREW, PAN HEAD	1	1	
18	92907-05100	.WASHER, SPRING	1	1	
19	98507-05030	.SCREW, PAN HEAD	2	2	
20	90464-31827	CLAMP	2	2	(YMUS)

FWD
1P01100- D430

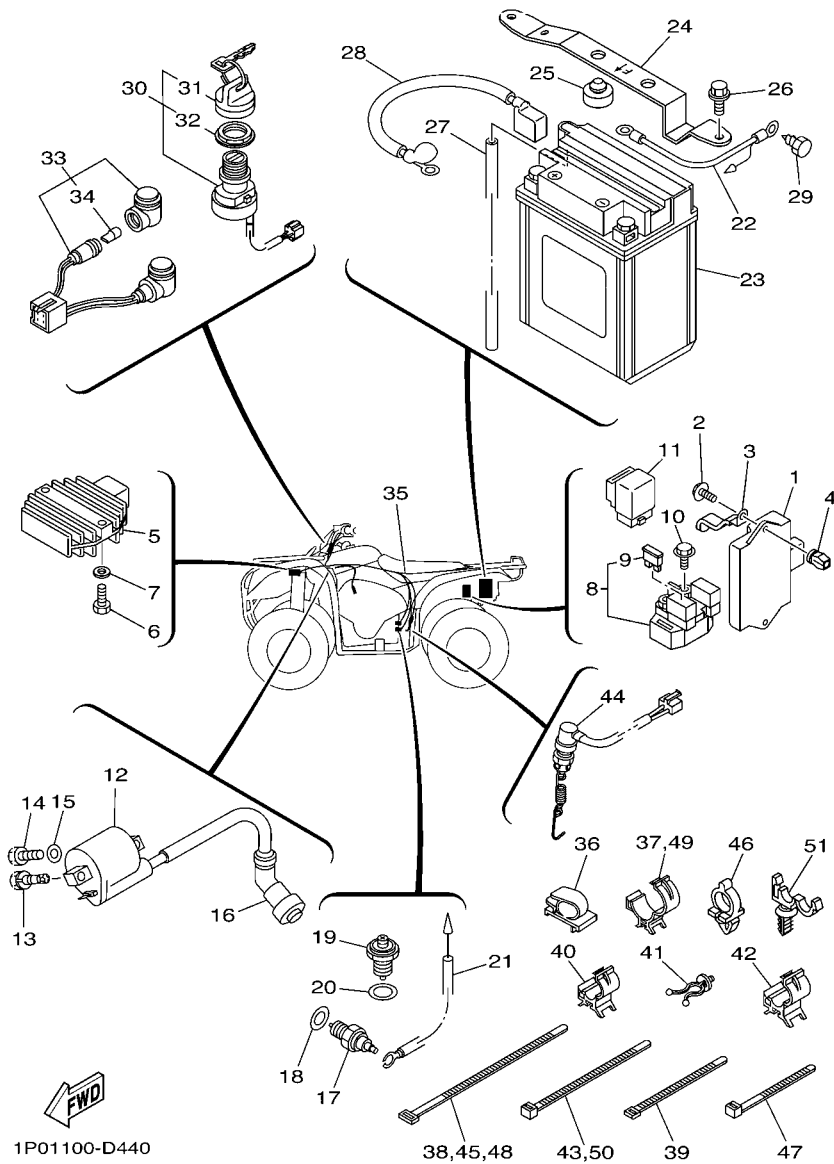

FIG. 44 ELECTRICAL 1

REF. NO.	PART NO.	DESCRIPTION	USA	CAN	REMARKS
1	1P0-85540-00	C.D.I. UNIT ASSY	1	1	
2	97707-60420	SCREW, TAPPING	1	1	
3	90462-06016	CLAMP	1	1	
4	90338-08226	PLUG	1	1	
5	5GT-81960-00	RECTIFIER & REGULATOR ASSY	1	1	
6	97007-06020	BOLT	2	2	
7	92907-06600	WASHER, PLATE	2	2	
8	4XE-81940-11	STARTER RELAY ASSY	1	1	
9	2GH-82151-00	.FUSE (20A-BL)	2	2	
10	9502P-06008	BOLT, FLANGE	2	2	(YMUS)
11	1RL-81950-92	RELAY ASSY	1	1	
12	4KJ-82310-10	IGNITION COIL ASSY	1	1	
13	90109-06873	BOLT	1	1	(YMUS)
14	97007-06020	BOLT	1	1	
15	92907-06600	WASHER, PLATE	1	1	
16	1UY-82370-20	PLUG CAP ASSY	1	1	
17	3GB-82540-01	NEUTRAL SWITCH ASSY	1	1	
18	90430-10148	GASKET	1	1	
19	4KD-82540-00	NEUTRAL SWITCH ASSY	1	1	
20	90201-12790	WASHER, PLATE	1	1	
21	5XG-H2507-00	WIRE, LEAD	1	1	(YMUS)
22	1P0-H2116-00	WIRE, MINUS LEAD	1	1	(YMUS)
23	4XE-H2100-20	BATTERY ASSY (GS CB14A-A2)	1	1	(YMUS)
24	1P0-H2128-00	BRACKET, BATTERY	1	1	(YMUS)
25	5TG-82121-10	PAD, BATTERY	2	2	
26	95807-06020	BOLT, FLANGE	2	2	
27	1P0-H2112-00	PIPE, BREATHER	1	1	(YMUS)

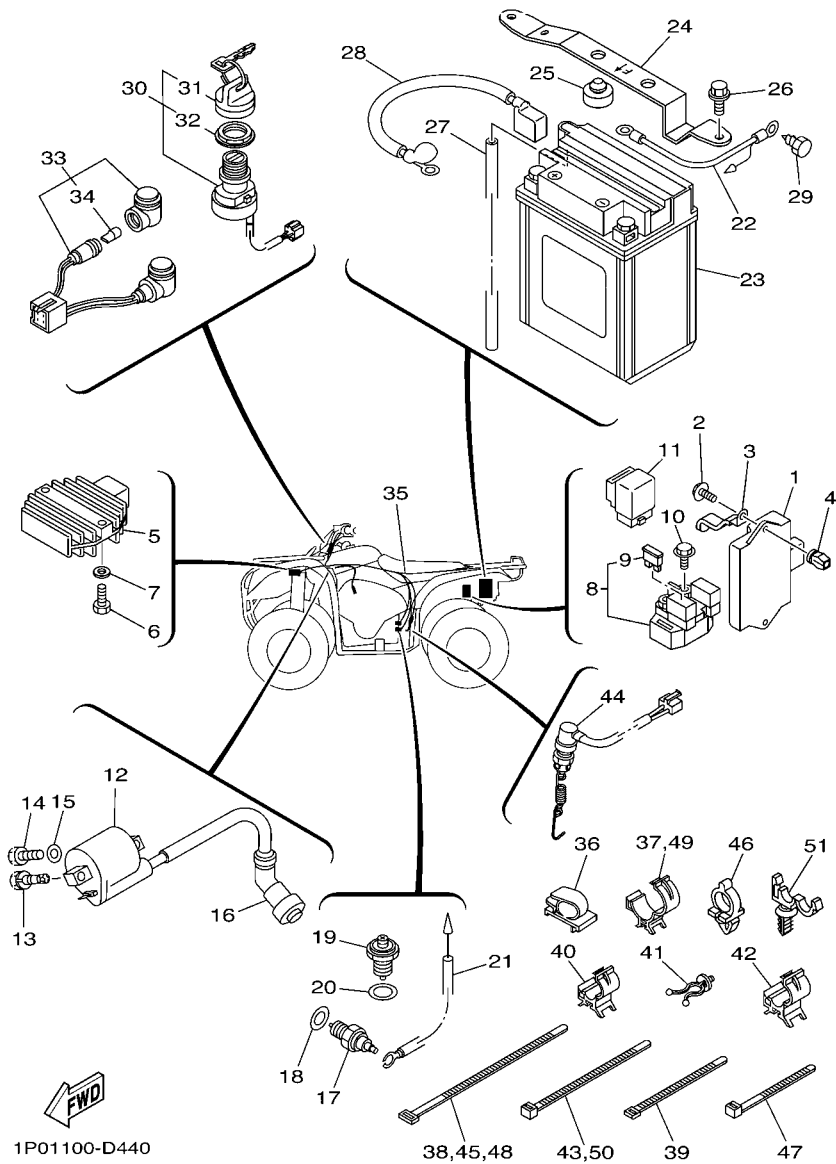
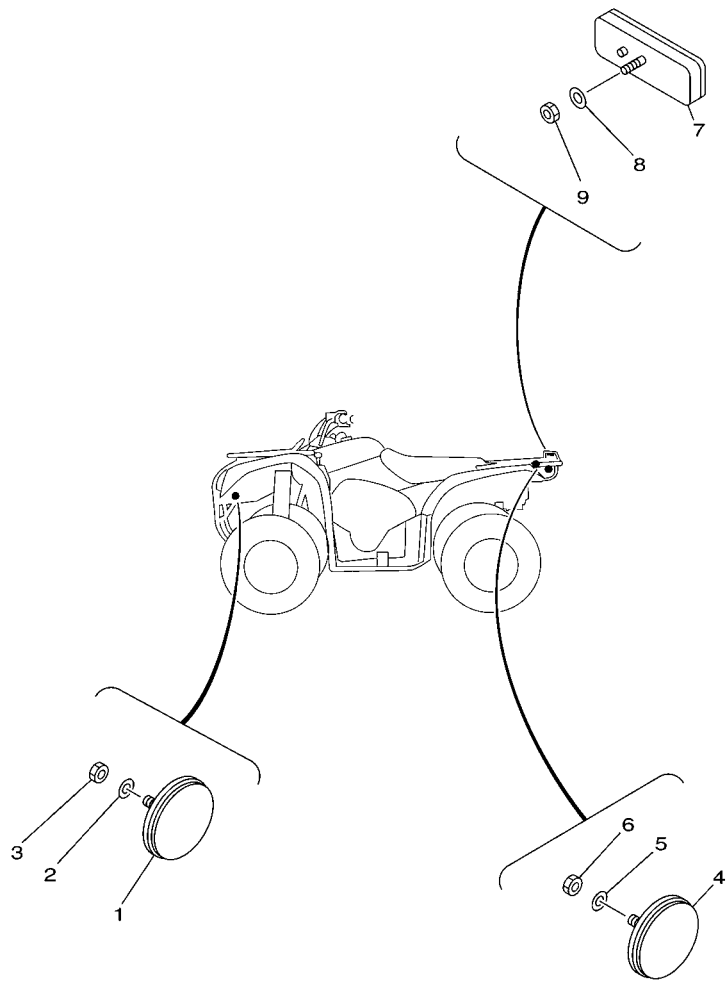

FIG. 44 ELECTRICAL 1

REF. NO.	PART NO.	DESCRIPTION	USA	CAN	REMARKS
28	1P0-H2115-00	WIRE, PLUS LEAD	1	1	(YMUS)
29	9770P-60416	SCREW, TAPPING	1	1	(YMUS)
30	4XE-82510-00	MAIN SWITCH ASSY	1	1	
31	3HN-82579-00	.CAP, KEY	1	1	
32	3HN-82569-00	.NUT, MAIN SWITCH	1	1	
33	5TE-83530-00	PILOT LIGHT ASSY	1	1	
34	5GH-83516-00	.BULB (14V-1.7W)	2	2	
35	1P0-82590-00	WIRE HARNESS ASSY	1	1	
36	90464-13831	CLAMP	1	1	(YMUS)
37	90464-20835	CLAMP	1	1	(YMUS)
38	90464-48837	CLAMP	1	1	(YMUS)
39	3TB-83936-00	BAND, SWITCH CORD	1	1	
40	90464-08834	CLAMP	5	5	(YMUS)
41	90464-12836	CLAMP	1	1	(YMUS)
42	90464-10842	CLAMP	3	3	(YMUS)
43	90464-40825	CLAMP	2	2	(YMUS)
44	4XE-82530-10	STOP SWITCH ASSY	1	1	
45	90464-48837	CLAMP	1	1	(YMUS)
46	90464-10833	CLAMP	2	2	(YMUS)
47	90464-31827	CLAMP	2	2	(YMUS)
48	90464-48837	CLAMP	1	1	(YMUS)
49	90464-20835	CLAMP	1	1	(YMUS)
50	90464-40825	CLAMP	1	1	(YMUS)
51	90464-12830	CLAMP	1	1	(YMUS)



1P011100-D40

FIG. 45 ELECTRICAL 2

REF. NO.	PART NO.	DESCRIPTION	USA	CAN			REMARKS
1	2EK-85111-00	REFLECTOR, FRONT 1		2			
2	92907-05200	WASHER		2			
3	95307-05600	NUT		2			
4	449-85131-02	REFLECTOR, REAR 1		2			
5	92907-05200	WASHER		2			
6	95307-05600	NUT		2			
7	3Y6-85130-02	REAR REFLECTOR ASSY		1			
8	92907-05200	WASHER		1			
9	95307-05600	NUT		1			

FIG. 46 EMBLEM & LABEL 1

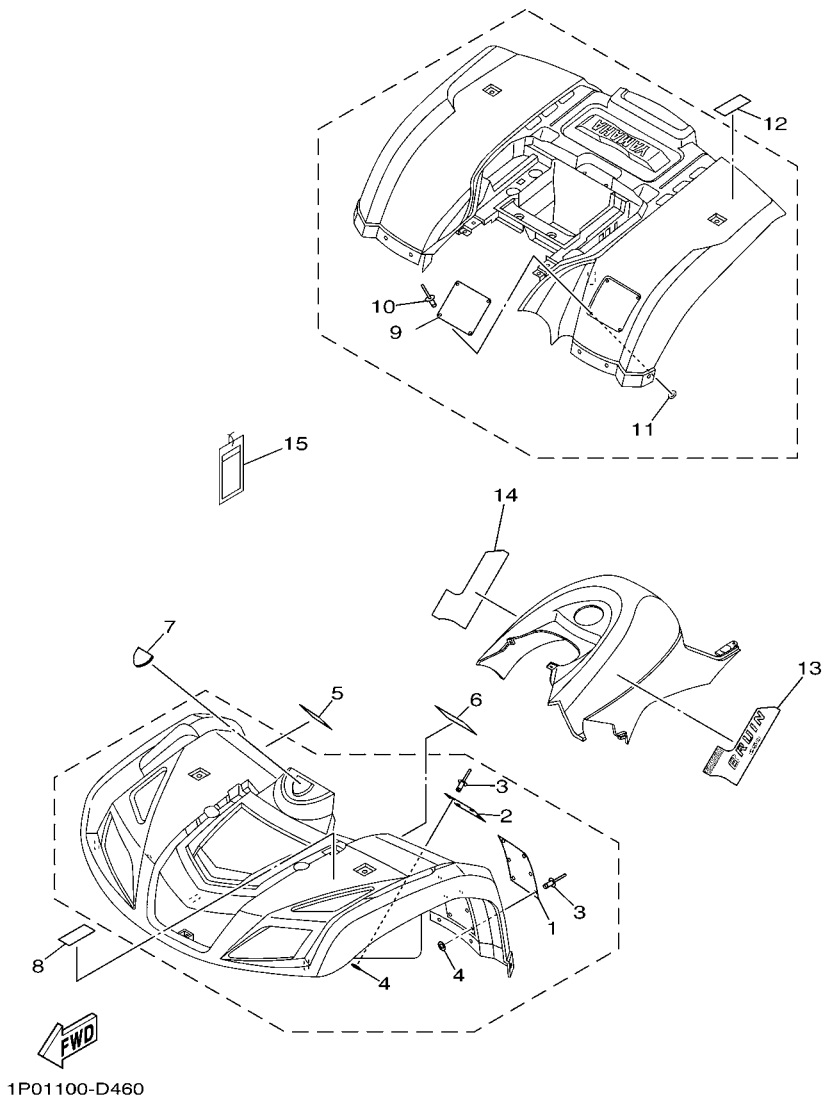

1P01100-D460

REF. NO.	PART NO.	DESCRIPTION	USA	CAN	REMARKS
1	4XE-F1568-00	LABEL, WARNING	1		ENGLISH (YMUS)
2	4XE-F415A-00	LABEL, CAUTION	1		ENGLISH (YMUS)
3	4XE-F1539-10	RIVET	10		(YMUS)
4	4XE-F1549-00	WASHER, FENDER MOLD	10		(YMUS)
5	4XE-F1578-00	EMBLEM	1		(YMUS)
6	4XE-F151E-01	LABEL 2	1		ENGLISH (YMUS)
7	5FU-F6232-00	EMBLEM 3D	1		(YMUS)
8	4XE-F4877-30	LABEL, CAUTION	1		(YMUS)
9	4XE-F1696-00	LABEL, CAUTION	1		(YMUS)
10	4XE-F1539-10	RIVET	4		(YMUS)
11	4XE-F1549-00	WASHER, FENDER MOLD	4		(YMUS)
12	4XE-F4897-30	EMBLEM	1		(YMUS)
13	1P0-F1781-00	EMBLEM 1	1		FOR RTR (YMUS)
	1P0-F1781-10	EMBLEM 1	1		FOR PDG (YMUS)
	1P0-F1781-20	EMBLEM 1	1		FOR DPBSN (YMUS)
14	1P0-F1782-00	EMBLEM 2	1		FOR RTR (YMUS)
	1P0-F1782-10	EMBLEM 2	1		FOR PDG (YMUS)
	1P0-F1782-20	EMBLEM 2	1		FOR DPBSN (YMUS)
15	4XE-F819R-10	TAG, WARNING	1		(YMUS)

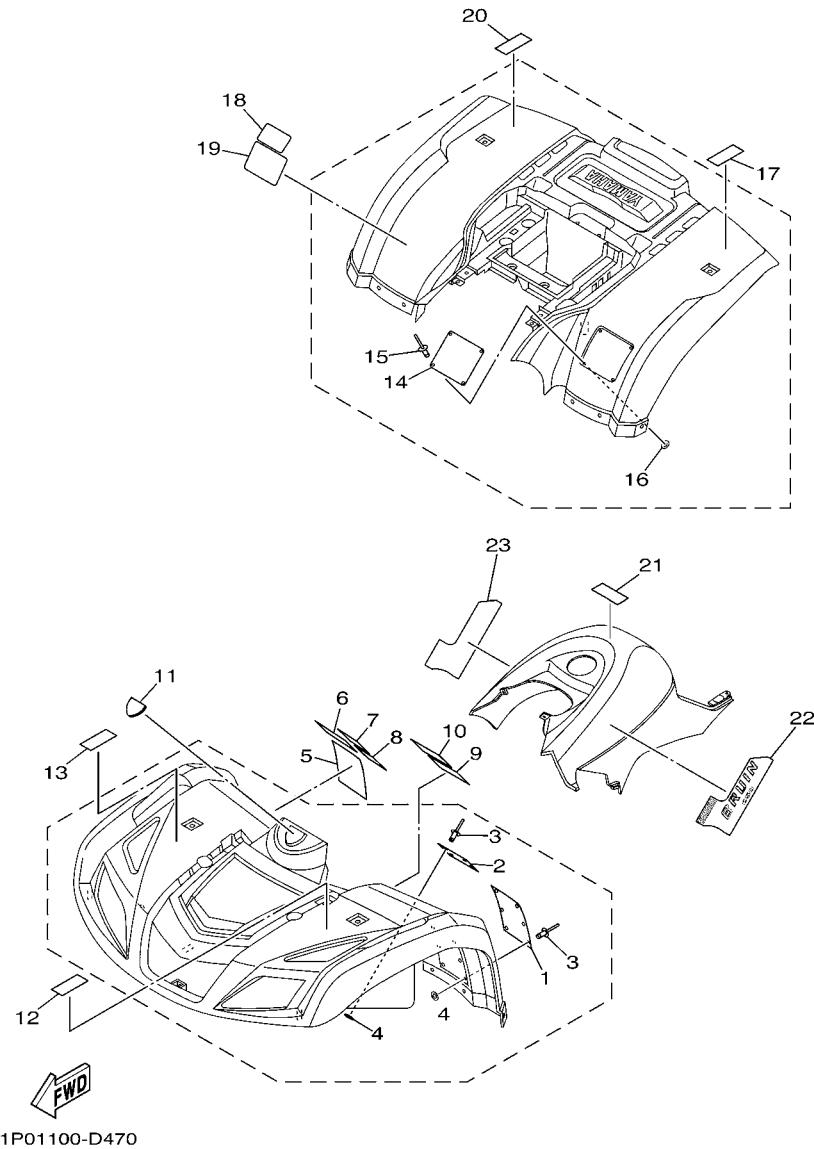

FIG. 47 EMBLEM & LABEL 2

REF. NO.	PART NO.	DESCRIPTION	USA	CAN	REMARKS
1	4XE-F1568-00	LABEL, WARNING		1	ENGLISH (YMUS)
2	4XE-F415A-00	LABEL, CAUTION		1	ENGLISH (YMUS)
3	4XE-F1539-10	RIVET		10	(YMUS)
4	4XE-F1549-00	WASHER, FENDER MOLD		10	(YMUS)
5	4XE-F1568-20	LABEL, WARNING		1	FRENCH (YMUS)
6	4XE-F415A-10	LABEL, CAUTION		1	FRENCH (YMUS)
7	4XE-F1578-00	EMBLEM		1	(YMUS)
8	4XE-F1578-10	EMBLEM		1	(YMUS)
9	4XE-F151E-01	LABEL 2		1	ENGLISH (YMUS)
10	4XE-F151E-11	LABEL 2		1	FRENCH (YMUS)
11	5FU-F6232-00	EMBLEM 3D		1	(YMUS)
12	4XE-F4877-30	LABEL, CAUTION		1	(YMUS)
13	4XE-F4877-40	LABEL, CAUTION		1	(YMUS)
14	4XE-F1696-00	LABEL, CAUTION		1	(YMUS)
15	4XE-F1539-10	RIVET		4	(YMUS)
16	4XE-F1549-00	WASHER, FENDER MOLD		4	(YMUS)
17	4XE-F4897-30	EMBLEM		1	(YMUS)
18	4XE-F151H-10	LABEL 5		1	FRENCH (YMUS)
19	4XE-F1696-10	LABEL, CAUTION		1	FRENCH (YMUS)
20	4XE-F4897-40	EMBLEM		1	(YMUS)
21	4XE-F416E-00	LABEL, CAUTION CANADA		1	(YMUS)
22	1P0-F1781-20	EMBLEM 1		1	(YMUS)
23	1P0-F1782-20	EMBLEM 2		1	(YMUS)

NUMERICAL INDEX

PART NO.	GRID NO.	PART NO.	GRID NO.	PART NO.	GRID NO.	PART NO.	GRID NO.	PART NO.	GRID NO.	PART NO.	GRID NO.
5H0-11133-11	B - 2	3YF-14714-00	B - 13	5GH-18617-00	C - 10	1RL-81950-92	E - 13	5XG-E1186-00	B - 2	5XG-E5317-00	B - 15
4XE-11166-00	B - 2	5EL-1490H-00	B - 12	1P0-2179T-00	B - 9	5GT-81960-00	E - 13	5XG-E1187-00	B - 2	5XG-E5351-00	B - 10
3GH-11181-00	B - 2	1P0-1490J-00	B - 11	1W1-22128-00	D - 8	5TG-82121-10	E - 13	5XG-E1310-00	B - 4	5XG-E5362-00	B - 15
214-11198-01	D - 5	5GH-14918-10	B - 11	29U-22189-00	D - 4	2GH-82151-00	E - 13	5XG-E1400-00	B - 5	5XG-E5381-00	C - 2
5VC-11351-00	B - 4	5DM-14933-00	B - 11	2HR-23526-00	D - 9	4KJ-82310-10	E - 13	5XG-E1422-00	B - 5	5XG-E5431-00	B - 15
4BD-11631-00-Y0	B - 5	4XE-14937-00	B - 12	1UY-23812-00	D - 10	1UY-82370-20	E - 13	5XG-E1454-00	B - 5	5XG-E5499-00	B - 15
4BD-11636-00	B - 5	5GH-14937-00	B - 12	8K1-23814-00	D - 10	4XE-82510-00	E - 14	5XG-E1531-00	B - 5	1P0-E5512-00	C - 4
4BD-11638-00	B - 5	5GH-14940-10	B - 11	1P0-24311-00	D - 11	4XE-82530-10	E - 14	5XG-E1536-00	B - 5	5XG-E5517-00	C - 4
4G0-12113-01	B - 7	256-14956-01	B - 12	4BD-24339-00	D - 11	4KD-82540-00	E - 13	5XG-E1603-00	B - 5	5XG-E5521-00	C - 4
4G0-12114-01	B - 7	3H1-14962-00	B - 11	3JN-24500-02	D - 11	3GB-82540-01	E - 13	5XG-E1605-00	B - 5	4XE-E5710-00	C - 3
4G0-12116-01	B - 7	5DM-14985-00	B - 12	4X8-24512-00	D - 11	3HN-82569-00	E - 14	5XG-E1607-00	B - 5	4XE-E5711-00	C - 3
4G0-12117-00	B - 7	7T9-14987-00	B - 12	3AJ-24534-01	D - 11	3HN-82579-00	E - 14	5XG-E1633-00	B - 5	4XE-E5713-00	C - 3
4G0-12118-00	B - 7	2N4-15371-00	D - 5	5KM-24610-00	D - 11	1P0-82590-00	E - 14	5XG-E1651-00	B - 5	4XE-E5714-00	C - 3
5H0-12119-00	B - 7	4BD-15451-01	B - 15	1UY-25117-00	D - 13	5FU-82910-23	E - 12	3UR-E1681-00	B - 5	4XE-E5715-00	C - 3
2NX-12159-00	B - 7	4BD-15462-00	B - 15	52H-2512A-00	D - 13	1YW-82911-02	E - 12	5XG-E2111-00	B - 7	4XE-E5716-00	C - 3
3GC-12210-10	B - 8	4BD-15463-01	B - 15		E - 2	2XJ-82913-00	E - 12	5XG-E2121-00	B - 7	5XG-E5723-00	C - 3
4FM-12213-00	B - 8	31A-15580-00	C - 4	4SH-25367-01	D - 15	4V4-82913-00	E - 3	3UR-E2146-00	B - 7	4XE-E5741-00	C - 3
4BE-13329-01	B - 10	1J7-15583-01	C - 4	3GD-2580T-00	D - 14	5GH-83516-00	E - 14	5XG-E2151-00	B - 7	4XE-E5744-00	C - 3
51Y-13411-00	B - 10	21V-15719-00	B - 15	3GD-2580U-00	D - 14	5TE-83530-00	E - 14	3UR-E2156-00	B - 7	4XE-E5751-00	C - 3
1P0-13586-00	B - 9	21V-16358-00	C - 5	3GD-25827-00	D - 14	1UY-83909-00	E - 12	5XG-E2171-00	B - 8	4XE-E5755-00	C - 3
5UH-14103-00	B - 12	21V-16664-00	C - 5	3GD-25828-00	D - 14	2HT-83912-00	E - 12	5XG-E2176-00	B - 8	4XE-E5767-00	C - 3
5FU-14105-10	B - 11	24W-17151-02	C - 6	5KM-2583T-01	E - 4	5KM-83922-00	E - 4	3UR-E2231-00	B - 8	4XE-E5779-00	C - 3
4KM-14107-20	B - 11	4BD-17251-00	C - 6	5JX-25852-01	E - 4	3TB-83936-00	E - 14	5XG-E2241-00	B - 8	5XG-E5787-00	B - 15
5UH-1410A-00	B - 11	52G-17531-01	C - 7	4L0-25854-00	E - 4	5GH-83941-00	E - 12	5XG-E3300-00	B - 10	4XE-E5789-00	C - 3
5DM-14112-00	B - 11	52G-17531-11	C - 7	2GU-25866-00	E - 4	3L4-83943-00	E - 12	5XG-E3326-00	B - 10	4XE-E5793-00	C - 3
5DM-14141-42	B - 11	52G-17531-21	C - 7	5GH-25867-00	E - 4	1YW-83965-00	E - 12	3UH-E3440-00	B - 10	5XG-E6150-00	C - 5
4KM-14142-17	B - 12	52G-17531-31	C - 7	1FK-2589F-00	E - 4	5LP-83973-01	E - 12	5XG-E3447-00	B - 10	5XG-E6154-00	C - 5
3H1-14147-00	B - 11	52G-17531-41	C - 7	3GD-25933-00	D - 14	5LP-83980-00	E - 4	1P0-E4101-00	B - 11	5XG-E6321-00	C - 5
3G2-1414A-63	B - 11	52G-17531-51	C - 7	1NV-26129-00	E - 3	3FA-83980-03	E - 12	5FU-E4147-00	B - 11	5XG-E6324-00	C - 5
3G2-1414A-69	B - 11	24W-17537-10	C - 7	4KB-26250-10	E - 3	2GU-84332-00	E - 9	5FU-E4155-00	B - 12	5XG-E6351-00	C - 5
522-14161-00	B - 11	24W-17537-20	C - 7	1NV-2625G-01	E - 3	2GU-84334-00	E - 9	5ND-E4191-00	C - 10	5XG-E6352-00	C - 5
5FU-14167-00	B - 12	24W-17537-30	C - 7	4KB-2628F-10	E - 3	5KM-84710-00	E - 10	5UH-E4349-00	B - 9	5XG-E6371-00	C - 5
127-14186-00	B - 11	24W-17537-40	C - 7	4KB-2628G-00	E - 3		E - 11	4XE-E4411-00	B - 9	5XG-E6611-00	C - 5
3FV-14191-00	B - 11	24W-17537-50	C - 7	1NV-26304-00	E - 3	1A2-84714-41	E - 10	4XE-E4412-00	B - 9	5XG-E6620-00	C - 5
24W-14193-00	B - 12	24W-17537-60	C - 7	1P0-26311-00	E - 3		E - 11	JN6-E4424-00	B - 9	5XG-E6626-00	C - 5
4KB-14193-20	B - 11	52G-17967-20	C - 7	5EB-26332-00	E - 4	5KM-8472C-10	E - 10	4XE-E442F-00	B - 9	5XG-E6665-00	C - 5
5FU-14197-00	B - 12	52G-17967-30	C - 7	1P0-26341-00	E - 3		E - 11	4XE-E4437-00	B - 9	5XG-E7121-00	C - 6
3DM-14216-00	B - 12	52G-17967-40	C - 7	20E-26343-00	E - 3	5GH-84751-10	E - 11	4XE-E4438-00	B - 9	5XG-E7131-00	C - 6
4KM-14216-00	B - 11	24W-18104-00	C - 13		E - 5	2EK-85111-00	E - 15	4XE-E4450-00	B - 9	5XG-E7141-00	C - 6
1HX-14231-16	B - 11	1P0-18110-00	C - 13	1P0-2637F-00	E - 5	3Y6-85130-02	E - 15	1P0-E4453-00	B - 9	5XG-E7211-00	C - 6
5DM-14261-00	B - 11	22N-18113-00	C - 13	1NV-26398-00	E - 3	449-85131-02	E - 15	4XE-E4457-00	B - 9	5XG-E7221-00	C - 6
5UH-14348-00	B - 12	5GH-18131-00	C - 10	109-27114-00	D - 4	1P0-85540-00	E - 13	4XE-E4462-00	B - 9	5XG-E7231-00	C - 6
31A-14419-00	B - 9	1P0-18174-00	C - 10	4XE-27231-00	E - 5	5XG-E1102-00	B - 2	4XE-E4611-10	B - 13	1P0-E7241-00	C - 6
5BF-1443E-00	D - 2	24W-18179-00	C - 13	1NV-2811A-01	C - 14	3UR-E111F-00	B - 3	4XE-E4612-10	B - 13	5XG-E7285-00	C - 7
583-14561-00	B - 11	21V-18181-00	C - 13	29U-46125-00	D - 5	5XG-E1160-00	B - 2	4XE-E4628-00	B - 13	5XG-E7401-00	C - 6
5DM-14561-00	B - 11	52G-18187-00	C - 10	4X7-46180-00	D - 7	5XG-E1161-00	B - 2	4XE-E4710-20	B - 13	5XG-E7402-00	C - 6
1FN-14565-00	B - 12	1P0-18300-00	C - 10	1EV-81823-00	E - 8	5XG-E1162-00	B - 2	4XE-E4767-00	B - 13	4XE-E7537-15	D - 5
4BE-14613-00	B - 13	52G-18540-01	C - 12	4XE-81940-11	E - 13	5XG-E1165-00	B - 2	5XG-E5150-00	B - 14	4XE-E7537-30	D - 5

NUMERICAL INDEX

PART NO.	GRID NO.	PART NO.	GRID NO.	PART NO.	GRID NO.	PART NO.	GRID NO.	PART NO.	GRID NO.	PART NO.	GRID NO.
4XE-E7537-40	D - 5	5FU-F111A-00	C - 14	4XE-F2143-00	D - 4	5FU-F5336-00	E - 2	4XE-G6117-50	D - 6	90105-08195	B - 2
4XE-E7537-45	D - 5	4XE-F1315-00	C - 14	4XE-F214H-00	D - 4	5FU-F533A-10	D - 15	4XE-G6118-10	D - 6	90105-08805	C - 14
4XE-E7537-50	D - 6	4XE-F1399-00	E - 6	4XE-F219X-00	D - 4	5VH-F5351-00	D - 15	4XE-G6118-11	D - 6	90105-08806	C - 14
4XE-E7537-60	D - 6	1P0-F1453-00	C - 14	4XE-F2210-10	D - 8	1P0-F5355-00	D - 15	4XE-G6118-12	D - 6	90105-08888	C - 14
5XG-E7551-00	C - 8	1P0-F1500-00	C - 15	4XE-F3350-10	D - 9	5VH-F5359-00	D - 15	4XE-G6118-13	D - 6	90105-08892	E - 2
5XG-E7553-00	C - 7	1P0-F1500-10	C - 15	4XE-F3501-20	D - 9	5FU-F5377-10	E - 2	4XE-G6118-14	D - 6	90105-088B2	D - 14
5XG-E7556-00	C - 8	1P0-F1500-20	C - 15	4XE-F3502-20	D - 9	5FU-F537Y-00	E - 2	4XE-G6118-15	D - 6	90105-10801	B - 13
5XG-E7558-00	C - 6	4XE-F151E-01	F - 2	4XE-F3549-00	D - 9	1P0-F5381-00	E - 2	4XE-G6118-16	D - 6	90105-10890	D - 9
1P0-E7642-00	C - 8		F - 3	4XE-F3570-10	D - 9	5ND-F5383-00	D - 15	4XE-G6118-17	D - 6	90105-10893	D - 4
5XG-E7968-00	C - 7	4XE-F151E-11	F - 3	4XE-F3580-10	D - 9	5ND-F5383-10	D - 15	4XE-G6118-18	D - 6	90105-12889	D - 8
5XG-E7968-10	C - 7	4XE-F151H-10	F - 3	1P0-F3813-00	D - 10	5FU-F5384-00	E - 2	4XE-G6118-19	D - 6	90109-063F1	E - 6
5XG-E7968-20	C - 7	4XE-F151K-00	D - 4	4XE-F3831-00	D - 10	4XE-F5390-31	D - 15	4XE-G6118-20	D - 6	90109-06576	E - 12
5XG-E7968-30	C - 8	4XE-F151K-10	D - 4	4XE-F3833-00	D - 10	5VH-F539F-00	D - 15	4XE-G6118-21	D - 6	90109-06873	E - 13
5XG-E7968-40	C - 8	4XE-F1539-10	F - 2	4XE-F3834-00	D - 10	5VH-F5818-00	D - 15	4XE-G6118-A3	D - 6	90110-06817	B - 14
5XG-E7968-50	C - 8		F - 3	5FU-F3841-00	D - 10	4XE-F582T-10	D - 14	4XE-G6118-A4	D - 6	90114-10804	D - 13
5XG-E7968-60	C - 8	4XE-F1549-00	F - 2	5FU-F3845-00	D - 10	5VH-F5833-00	D - 15	4XE-G6118-A5	D - 6		D - 15
5XG-E7968-70	C - 8		F - 3	4XE-F3868-10	D - 10	4XE-F5871-00	E - 4	4XE-G6151-01	D - 5	90116-10840	D - 5
5XG-E7968-80	C - 8	4XE-F1568-00	F - 2	4XE-F3894-00	D - 10	4XE-F5872-00	E - 4	4XE-G6152-01	D - 5	90119-06060	C - 15
5XG-E7968-90	C - 8		F - 3	4XE-F4110-00	D - 11	4XE-F5873-00	E - 4	4XE-G6172-00	D - 6		D - 2
5XG-E8103-00	C - 13	4XE-F1568-20	F - 3	4XE-F414H-00	D - 11	4XE-F587A-00	E - 4	4XE-G6513-00	E - 2	90119-06227	D - 2
5XG-E8116-00	C - 11	4XE-F1578-00	F - 2	4XE-F415A-00	F - 2	5VH-F5898-00	D - 15	1P0-G6540-00	D - 4	90119-06831	D - 11
5XG-E8117-00	C - 10		F - 3		F - 3	5FU-F6111-10	E - 3	1P0-H1410-00	E - 7	90123-08046	E - 12
5XG-E8118-00	C - 13	4XE-F1578-10	F - 3	4XE-F415A-10	F - 3	1P0-F6124-00	E - 3	1P0-H1450-00	E - 7	90149-04278	E - 3
5XG-E8120-00	C - 13	1P0-F1585-00	C - 14	4XE-F416E-00	F - 3	4XE-F612K-10	E - 4	5XG-H1800-00	E - 8	90149-05299	C - 15
5XG-E8126-00	C - 13	1P0-F1600-00	D - 2	4XE-F4181-00	D - 11	5FU-F6232-00	F - 2	3KW-H1801-00	E - 8		E - 5
5XG-E8127-00	C - 13	1P0-F1600-10	D - 2	1P0-F4285-00	D - 2		F - 3	3KW-H1828-00	E - 8	90149-06011	D - 11
5XG-E812A-00	C - 8	1P0-F1600-20	D - 2	5UH-F470F-00	D - 12	5FU-F6241-10	E - 3	5XG-H183G-00	E - 8	90149-08152	C - 6
5XG-E8140-00	C - 13	1P0-F1649-00	D - 2	5UH-F4710-00	D - 12	1P0-F6331-00	E - 3	4XE-H2100-20	E - 13	90149-08268	D - 14
5XG-E8154-00	C - 10	1P0-F1651-00	D - 2	5UH-F4747-00	D - 12	1P0-F7211-00	E - 5	1P0-H2112-00	E - 13	90150-05802	E - 9
5XG-E8154-10	C - 10	1P0-F1651-10	D - 2	5UH-F4776-00	D - 12	1P0-F741A-00	E - 5	1P0-H2115-00	E - 14	90151-06013	C - 12
1P0-E8164-00	C - 10	1P0-F1651-50	D - 2	5UH-F478V-00	D - 12	1P0-F7452-00	E - 5	1P0-H2116-00	E - 13	90153-06803	B - 2
5XG-E8177-00	C - 13	4XE-F1696-00	F - 2	1P0-F4841-00	E - 6	1P0-F7453-00	E - 5	1P0-H2128-00	E - 13	90159-05011	C - 5
5XG-E817A-00	C - 13		F - 3	1P0-F4842-00	E - 6	1P0-F7462-00	E - 5	5XG-H2507-00	E - 13	90170-06128	B - 7
5XG-E8185-00	C - 12	4XE-F1696-10	F - 3	1P0-F4842-10	E - 6	1P0-F7463-00	E - 5	5FU-H4314-00	E - 9	90170-08261	C - 11
1P0-E8191-00	C - 10	1P0-F171A-00	D - 3	4XE-F4877-30	F - 2	5ND-F8100-00	C - 14	5FU-H4320-00	E - 9	90170-14839	B - 5
5XG-E8197-00	C - 8	1P0-F171A-10	D - 3		F - 3	4XE-F819R-10	F - 2	5FU-H4340-00	E - 9		C - 5
5XG-E8198-00	C - 8	1P0-F171A-50	D - 3	4XE-F4877-40	F - 3	5UH-F8309-00	C - 15	8CR-W0041-00	E - 4	90170-22371	C - 5
1P0-E8323-00	C - 8	5FU-F175B-01	C - 15	4XE-F4897-30	F - 2	5UH-F8349-00	C - 15	3GD-W0045-00	D - 14	90171-12816	D - 9
1P0-E8341-00	C - 10	1P0-F1781-00	F - 2		F - 3	1P0-F842M-00	E - 6	3GD-W0047-00	D - 14		D - 10
5XG-E8451-00	C - 8	1P0-F1781-10	F - 2	4XE-F4897-40	F - 3	1P0-F845N-00	E - 6	1UY-W0048-50	D - 14	90171-14817	D - 13
5XG-E8511-00	C - 12	1P0-F1781-20	F - 2	4XE-F5111-20	D - 13	1P0-F845N-10	E - 6	3GD-W0057-00	D - 14	90171-16001	E - 2
5XG-E8512-00	C - 12		F - 3	4XE-F514A-00	D - 14	4XE-G6101-01	D - 5	5XG-WE141-00	B - 5	90179-08148	E - 12
5XG-E8513-00	C - 12	1P0-F1782-00	F - 2	4XE-F5180-31	D - 13	4XE-G6102-00	D - 5	5VH-WF536-00	D - 15	90179-08893	C - 14
5XG-E8514-00	C - 8	1P0-F1782-10	F - 2	5FU-F5319-00	E - 2	4XE-G6117-25	D - 6	52G-Y1754-00	C - 7	90179-10540	D - 13
5XG-E8531-00	C - 12	1P0-F1782-20	F - 2	5FU-F531E-10	E - 2	4XE-G6117-30	D - 6	4XE-Y4612-00	D - 5		E - 2
5XG-E8534-00	C - 8		F - 3	5VH-F5321-10	D - 15	90101-10303	D - 6	90101-10303	B - 8	90179-12248	C - 8
5XG-E8535-00	C - 12	4XE-F2110-20	D - 4	5FU-F5327-00	E - 2	4XE-G6117-40	D - 6	90101-10568	B - 5	90179-16651	C - 7
1P0-F1110-00	C - 14	4XE-F2141-00	D - 4	5VH-F5333-00	D - 15	4XE-G6117-45	D - 6	90101-12882	D - 9	90179-28465	C - 7

NUMERICAL INDEX

PART NO.	GRID NO.	PART NO.	GRID NO.	PART NO.	GRID NO.	PART NO.	GRID NO.	PART NO.	GRID NO.	PART NO.	GRID NO.
90179-35625	D - 9	90249-12008	E - 5	90464-48837	E - 14	92907-05100	E - 12	93210-72800	B - 4	94110-10800	D - 15
90179-55464	C - 7	90269-05001	D - 3	90467-07029	D - 7	92907-05200	E - 15	93210-85706	D - 6	94580-41104	B - 8
90183-05008	E - 9	90269-05055	C - 10	90467-07093	E - 2	92907-05600	E - 3	93210-92800	B - 2	94700-00852	B - 3
90183-06053	C - 15	90269-06804	C - 15	90467-10008	D - 11	92907-06100	E - 8	93211-058A2	B - 2	95027-06012	B - 2
90183-08800	C - 15	90269-08813	D - 3	90467-14015	B - 2		E - 12	93211-51749	D - 5	95027-06025	B - 8
90185-10115	D - 10	90280-03017	B - 5	90467-15012	C - 10	92907-06200	C - 10	93306-00006	C - 5	9502P-06008	E - 13
90185-10844	D - 9	90280-05048	B - 5	90467-16195	D - 2		E - 5	93306-004YX	D - 13	95307-05600	E - 15
90185-12072	D - 8	90282-05013	B - 5	90468-15020	E - 2	92907-06600	B - 8	93306-006Y3	C - 7	95307-05700	E - 3
90201-05029	E - 5	90336-28053	D - 10	90480-01400	D - 11		E - 4	93306-008Y0	D - 15	95307-08700	C - 13
90201-06008	C - 10	90338-08226	E - 13	90480-18290	D - 11		E - 7	93306-078Y0	B - 15	95317-06700	E - 5
90201-06074	E - 10	90338-26136	C - 5	90501-04503	C - 4		E - 13		C - 7	95317-08600	C - 11
	E - 11	90338-34264	D - 4	90501-101A5	C - 8	92907-08600	C - 8	93306-202X2	C - 6	95606-06100	E - 4
90201-060L5	D - 11	90340-14029	D - 5	90501-10245	E - 5		C - 13	93306-202XM	D - 13	95607-05100	E - 3
90201-067P3	C - 10	90340-14046	D - 5	90501-10782	E - 3	92907-10100	B - 5	93306-203X0	B - 15	95607-06100	E - 12
90201-08093	C - 13	90340-14107	C - 10	90501-13800	C - 8	9290P-08600	D - 5	93306-204Y6	C - 6	9560L-06200	D - 15
90201-087G0	B - 2	90381-15040	C - 14	90501-16768	C - 13	93101-15101	C - 6	93306-278Y0	D - 15	9561P-12100	D - 9
90201-088C3	B - 2	90387-066J1	D - 11	90501-18576	B - 10	93101-17113	B - 15	93306-304Z7	B - 5	95707-05300	E - 5
90201-10118	E - 4	90387-07598	D - 11	90501-243J7	C - 5	93101-35097	D - 15	93306-304YE	C - 7	95707-06300	E - 10
90201-101J1	B - 13	90387-090R0	D - 10	90506-08227	C - 13	93101-38098	D - 5	93306-305Y6	D - 5		E - 11
	D - 4	90387-150R1	D - 13	90506-16482	E - 2	93101-52116	D - 5	93306-306I1	B - 5	95707-10500	D - 6
90201-107F8	B - 5	90387-1711G	D - 4	90506-18224	E - 5	93102-12803	C - 13	93310-530J3	B - 5	95707-12500	D - 4
90201-108C6	B - 8	90387-255H9	D - 5	90508-26539	C - 13	93102-14856	C - 9	93311-21044	D - 7	95807-06020	E - 13
90201-108P8	D - 10	90387-284T0	E - 2	90508-29570	C - 13	93102-22216	D - 13	93315-23607	C - 12	95807-06025	E - 4
90201-12588	C - 13	90389-25800	B - 8	91317-06018	B - 2	93102-25017	D - 4	93316-013Y0	D - 5	95807-08012	D - 4
90201-125F7	C - 8	90401-10159	E - 4	91317-06020	B - 9	93102-65386	D - 5	93317-855Y9	D - 5	95817-06016	C - 9
90201-12790	E - 13	90430-06014	B - 2		B - 10	93103-28141	B - 15	93332-000Y3	D - 4		C - 10
90201-127J6	D - 8	90430-10148	E - 13		C - 10	93104-09025	E - 3	93399-99917	C - 8	9581P-06016	E - 5
90201-128C9	C - 4	90430-12186	B - 2	91317-06025	B - 4	93105-26026	D - 13	93410-20038	C - 6	9581P-08012	C - 14
90201-144J2	C - 10	90445-07810	E - 2	91317-06035	B - 14	93106-47040	D - 15	93410-22039	C - 6		E - 6
90201-147P2	C - 10	90445-078C4	D - 7	91317-06085	B - 14	93112-31011	D - 10		D - 6	9581P-08016	E - 5
90201-148R0	D - 13	90445-08809	D - 11	91317-06115	B - 10	93210-07590	C - 13	93410-26067	C - 6		E - 6
90201-15700	C - 6	90446-16001	C - 10	91317-08016	C - 4	93210-09165	B - 7	93410-32826	D - 9	9581P-08030	D - 10
90201-15797	E - 5	90450-47001	B - 9	91317-08045	B - 2		C - 9	93420-28055	C - 5	9581P-10020	E - 5
90201-168R1	E - 2	90450-56006	B - 9	9131P-06020	B - 13	93210-13361	B - 4	93440-10085	B - 2	9581P-10045	D - 5
90201-25290	C - 4	90460-58124	B - 9	91401-16012	C - 13	93210-14805	C - 10	93440-20088	D - 7	9581P-12025	D - 4
90201-266F6	C - 5	90460-85135	D - 4	91401-20012	E - 5	93210-15414	C - 14	93450-17044	B - 5	95827-08020	C - 14
90201-404M6	C - 5	90460-99228	D - 4	91401-20015	C - 10	93210-16800	B - 6	93501-04805	C - 8	9582P-06012	C - 14
90202-05193	D - 11	90462-06016	E - 13	91401-20025	D - 10	93210-17718	D - 4	93603-12801	B - 10		D - 14
90209-17285	C - 6	90464-08834	E - 14	91401-25020	D - 9	93210-19841	B - 15	93604-10837	B - 8		E - 2
90209-18208	C - 6	90464-10833	E - 14		D - 10	93210-25711	E - 8	93604-16092	C - 12	97007-06012	B - 3
90209-23241	C - 6	90464-10842	E - 14		D - 15	93210-26606	E - 2	93604-20156	C - 12	97007-06016	E - 4
90215-06809	B - 3	90464-12830	E - 14	91401-30025	D - 8	93210-34800	B - 10	93608-30839	C - 13	97007-06020	E - 13
90215-14186	C - 5	90464-12836	E - 14		D - 13	93210-35895	B - 9	93612-16254	B - 2	97017-06020	E - 5
90215-14810	B - 5	90464-13831	E - 14	91401-30030	E - 2	93210-53800	C - 8	93615-12088	C - 4	9701P-06020	C - 13
90215-22259	C - 5	90464-20835	E - 14	91401-40030	E - 5	93210-548A1	B - 10	93700-06004	C - 14	97027-06016	B - 8
90240-06076	E - 5	90464-31827	E - 12	91A20-07010	B - 12	93210-55669	E - 8	93900-00810	D - 15	97027-08025	C - 8
90240-12092	D - 8		E - 14	92902-04100	B - 12	93210-57897	B - 2	93900-00813	D - 13	9702P-08025	D - 5
90249-12008	E - 3	90464-40825	E - 14	92907-04600	B - 12	93210-59531	D - 5	94107-10800	D - 13	9702P-08060	D - 10

NUMERICAL INDEX

PART NO.	GRID NO.	PART NO.	GRID NO.	PART NO.	GRID NO.	PART NO.	GRID NO.	PART NO.	GRID NO.	PART NO.	GRID NO.
97707-60420	E - 13										
9770P-60416	E - 14										
98501-04014	B - 12										
98507-03008	D - 11										
98507-03540	E - 9										
98507-04006	B - 11										
98507-04008	B - 12										
98507-04014	B - 11										
98507-05020	E - 3										
98507-05030	E - 12										
98507-06016	E - 7										
	E - 8										
98507-06020	B - 2										
	C - 3										
	E - 12										
98507-06025	B - 15										
98507-06030	B - 14										
98507-06040	B - 14										
	B - 15										
98507-06060	B - 14										
	B - 15										
98507-06070	B - 15										
98507-06075	B - 14										
98507-06080	B - 15										
98507-06085	B - 14										
98517-05012	E - 12										
98580-04010	B - 11										
98706-04012	E - 4										
98707-05016	B - 15										
98707-06018	C - 2										
98707-06030	B - 10										
98907-06014	B - 15										
99009-12400	C - 4										
99009-14400	C - 8										
99009-26400	B - 6										
99530-10014	B - 14										
99530-12016	B - 14										
	B - 15										
99530-14016	B - 2										
	B - 4										