



# PARTS CATALOGUE

**YFM25BW** (1P09) U.S.A.

**YFM25BW** (1P0A) CANADA

**YFM25BW** (1P0B) EUROPE

**YFM25W** (1P0C) OCEANIA



2008/7/28

1F1P0-100E1

( 2F1P0-100E1 )

NEWS NO.	DATE	COMMENT
PE0-MC-060100	Aug.,8,2006	FIG.39 ILLUSTRATION CORRECTION
PE0-MC-070006	Jan.,15,2007	FOREWORD SERIAL NO ILLUSTRATION REVISION
PE0-MC-070060	Nov.,21,2007	FIG.16 SHIFTCAM & FORK ILLUSTRATION CORRECTION
PE0-MC-080040	Jul., 4, 2008	HEADLIGHT LIST/ILLUSTRATION. REVISION

YFM25BW/YFM25W  
PARTS CATALOGUE  
©2006 by Yamaha Motor Co., Ltd.  
1st edition, June 2006  
All rights reserved.  
Any reprinting or unauthorized use  
without the written permission of  
Yamaha Motor Co., Ltd.  
is expressly prohibited.

**A3**



**A4**

# FOREWORD

This Parts Catalogue is related to the parts for the model(s) on the cover page. When you are ordering replacement parts, please refer to this Parts Catalogue and quote both part numbers and part names correctly.

1. Modifications or additions which have been made after the issue of the Parts Catalogue will be announced in the Parts News.

It is advisable that you make the necessary corrections to the Parts Catalogue according to the Parts News.

2. Abbreviations

The following abbreviations are used in this Parts Catalogue.

“UR” Use specified parts number.

“UN” Use as many as needed.

“AP” Alternate Parts

“LM” Locally Made (Parts need to be ordered locally)

“F#” Frame No. (Applicable machine No.)

“O/S” Over Size

3. The number of components for assembly

- Parts, which are to be supplied in an assembly, are listed with a dot (.) in front of the part name as shown below.
- The numeral appearing to the right of each component part indicates the quantity of parts for each assembly unit.

PART NO.	DESCRIPTION	Q'TY	REMARKS
2F5-83310-60	FRONT FLASHER LIGHT ASSY	2	
115-83311-60	.BULB (6V-18W)	1	

4. Applicable colours of graphics are represented in the “REMARKS” as shown below.

PART NO.	DESCRIPTION	Q'TY	REMARKS
2N4-24110-00-X5	FUEL TANK COMP.	2	MXR
3J1-24240-10	.GRAPHIC, FUEL TANK	1	FOR MXR

5. Note that the illustrations for reference in finding parts numbers are not to be used for assembling. When assembling, please use the applicable service manual.

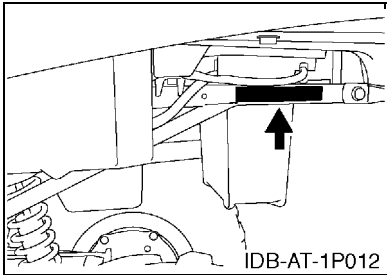
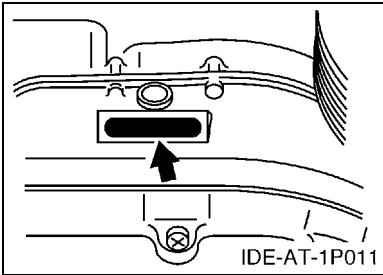
6. The asterisk (\*) before a reference number indicates modified items after the first edition.

# FOREWORD

7. Applicable Serial No.

Engine Serial No.

Frame Serial No.



8. Applicable Colour Code (The (\*) mark shows Model colour.)

Abbreviation	Colour Name	Colour Code
DPBSE(*)	DEEP PURPLISH BLUE SOLID E	0583
DPBSN(*)	DARK PURPLISH BLUE SOLID N	0891
PDG(*)	PASTEL DEEP GREEN	00K0
RTR(*)	ROMANTIQUE ROUGE	00TR

9. Quantity Column Information

Column No.	Name Of Q'ty Column	Destination
1	USA	U.S.A.
2	CAN	CANADA
3	EUR	EUROPE
4	OCE	OCEANIA



# CONTENTS

## ENGINE

CYLINDER HEAD .....	B2
CYLINDER .....	B4
CRANKSHAFT & PISTON .....	B5
VALVE .....	B7
CAMSHAFT & CHAIN .....	B8
INTAKE .....	B9
OIL PUMP .....	B10
CARBURETOR .....	B11
EXHAUST .....	B13
CRANKCASE .....	B14
CRANKCASE COVER 1 .....	B15
STARTER .....	C3
STARTER CLUTCH .....	C4
CLUTCH .....	C5
TRANSMISSION .....	C6
MIDDLE DRIVE GEAR .....	C7
DRIVE SELECTOR .....	C10
SHIFT CAM & FORK .....	C12
SHIFT SHAFT .....	C13

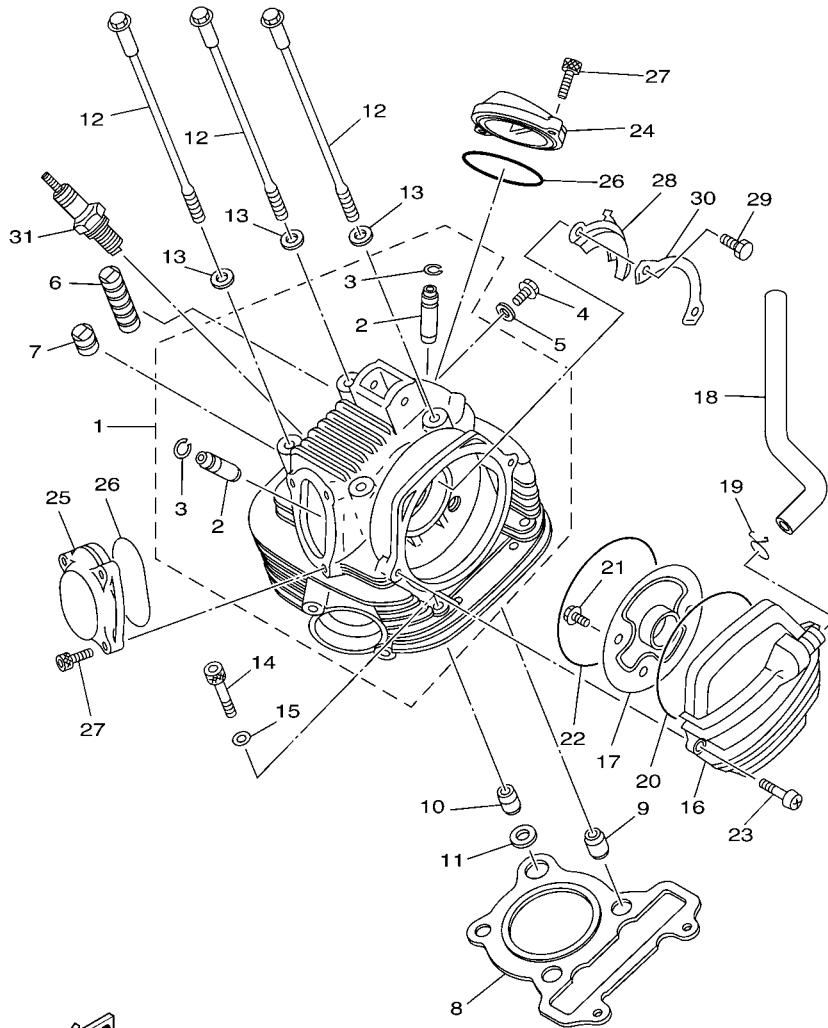
## CHASSIS

FRAME .....	C14
FRONT FENDER .....	C15
REAR FENDER .....	D2
SIDE COVER .....	D3
REAR ARM .....	D4
DRIVE SHAFT .....	D5
REAR SUSPENSION .....	D8
FRONT SUSPENSION & WHEEL .....	D9
STEERING .....	D10
FUEL TANK .....	D11
SEAT .....	D12
FRONT WHEEL .....	D13
FRONT BRAKE CALIPER .....	D14
REAR WHEEL .....	D15
STEERING HANDLE & CABLE .....	E3
FRONT MASTER CYLINDER .....	E4
STAND & FOOTREST .....	E5
GUARD .....	E6
GENERATOR .....	E7
STARTING MOTOR .....	E8

HEADLIGHT .....	E9
TAILLIGHT .....	E10
TAILLIGHT 2 .....	E11
HANDLE SWITCH & LEVER .....	E12
ELECTRICAL 1 .....	E13
ELECTRICAL 2 .....	F2
EMBLEM & LABEL 1 .....	F3
EMBLEM & LABEL 2 .....	F4
EMBLEM & LABEL 3 .....	F5
EMBLEM & LABEL 4 .....	F6

## INDEX

NUMERICAL INDEX .....	M1
-----------------------	----



  
 1P01100-D010

**FIG. 1 CYLINDER HEAD**

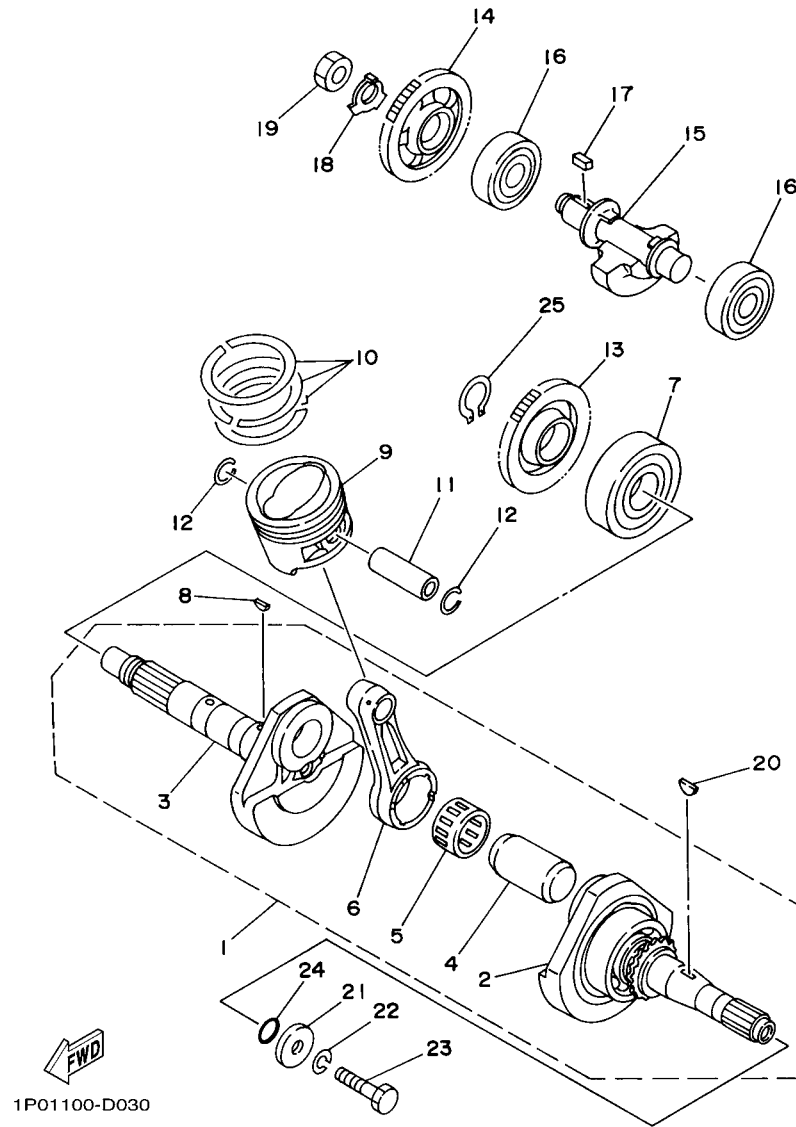
REF. NO.	PART NO.	DESCRIPTION	USA	CAN	EUR	OCE	REMARKS
1	5XG-E1102-01	CYLINDER HEAD ASSY	1	1	1	1	
2	5H0-11133-11	.GUIDE, VALVE 1	2	2	2	2	
3	93440-10085	.CIRCLIP	2	2	2	2	
4	90153-06803	SCREW, HEXAGON	1	1	1	1	
5	90430-06014	GASKET	1	1	1	1	
6	5XG-E1162-00	ABSORBER 2	1	1	1	1	
7	5XG-E1161-00	ABSORBER 1	1	1	1	1	
8	3GH-11181-00	GASKET, CYLINDER HEAD 1	1	1	1	1	
9	99530-14016	PIN, DOWEL	2	2	2	2	
10	93612-16254	PIN, DOWEL	1	1	1	1	
11	90430-12186	GASKET	1	1	1	1	
12	90105-08195	BOLT, FLANGE	4	4	4	4	
13	90201-088C3	WASHER, PLATE	4	4	4	4	
14	91317-08045	BOLT	2	2	2	2	
15	90201-087G0	WASHER, PLATE	2	2	2	2	
16	5XG-E1160-01	BREATHER ASSY	1	1	1	1	
17	5XG-E1165-00	PLATE, BREATHER	1	1	1	1	
18	4XE-11166-00	PIPE, BREATHER 1	1	1	1	1	
19	90467-14015	CLIP	1	1	1	1	
20	93210-92800	O-RING	1	1	1	1	
21	95027-06012	BOLT, FLANGE	2	2	2	2	
22	93211-058A2	O-RING	1	1	1	1	
23	98507-06020	SCREW, PAN HEAD	2	2	2	2	
24	5XG-E1186-00	COVER, CYLINDER HEAD SIDE 2	1	1	1	1	
25	5XG-E1187-00	COVER, CYLINDER HEAD SIDE 3	1	1	1	1	
26	93210-57897	O-RING	2	2	2	2	
27	91317-06018	BOLT	5	5	5	5	







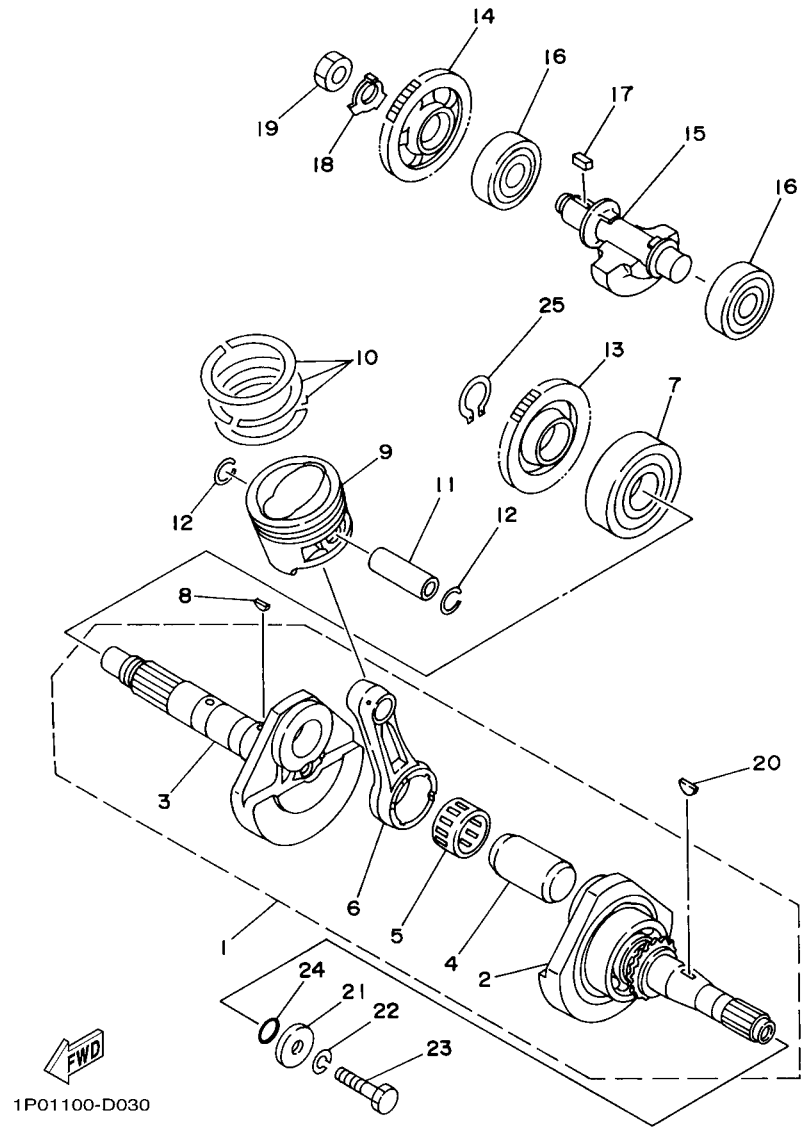
**FIG. 3 CRANKSHAFT & PISTON**



1P01100-D030

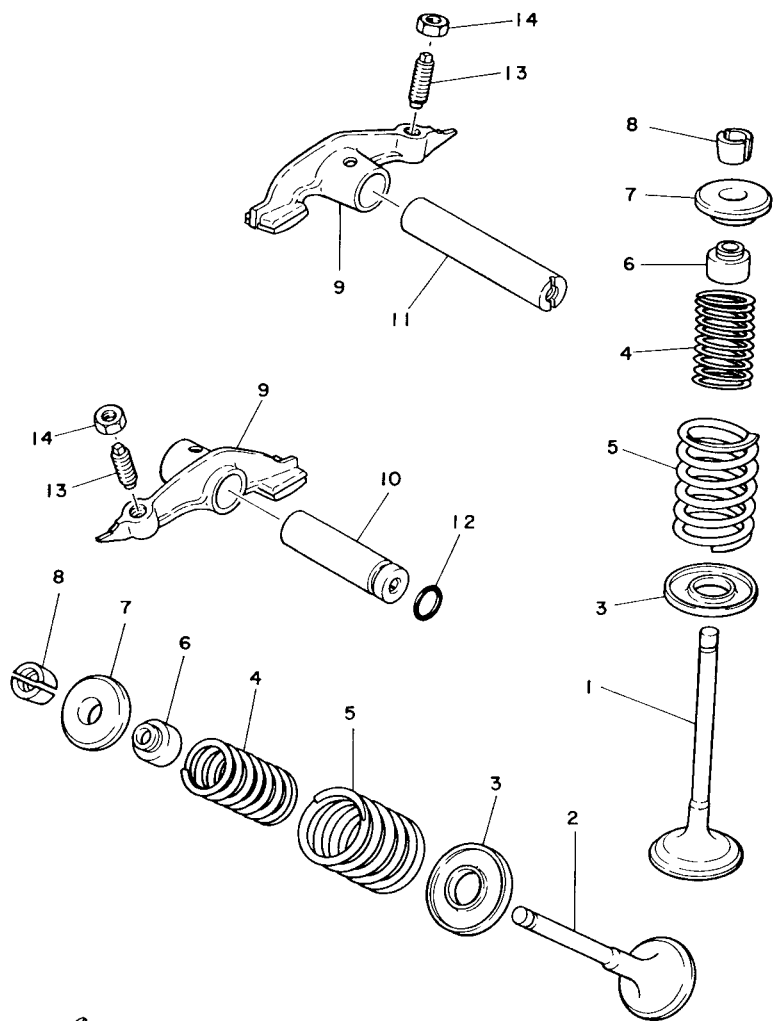
REF. NO.	PART NO.	DESCRIPTION	USA	CAN	EUR	OCE	REMARKS
1	5XG-E1400-00	CRANKSHAFT ASSY	1	1	1	1	
2	5XG-WE141-00	.CRANK 1	1	1	1	1	
3	5XG-E1422-00	.CRANK 2	1	1	1	1	
4	3UR-E1681-00	.PIN, CRANK 1	1	1	1	1	
5	93310-530J3	.BEARING	1	1	1	1	
6	5XG-E1651-00	.ROD, CONNECTING	1	1	1	1	
7	93306-30611	BEARING	1	1	1	1	
8	90280-03017	KEY, WOODRUFF	1	1	1	1	
9	4BD-11631-00-Y0	PISTON (STD)	1	1	1	1	
	4BD-11636-00	PISTON (0.50MM O/S)	1	1	1	1	AP
	4BD-11638-00	PISTON (1.00MM O/S)	1	1	1	1	AP
10	5XG-E1603-00	PISTON RING SET (STD)	1	1	1	1	
	5XG-E1605-00	PISTON RING SET (0.50MM O/S)	1	1	1	1	AP
	5XG-E1607-00	PISTON RING SET (1.00MM O/S)	1	1	1	1	AP
11	5XG-E1633-00	PIN, PISTON	1	1	1	1	
12	93450-17044	CIRCLIP	2	2	2	2	
13	5XG-E1536-00	GEAR, DRIVE	1	1	1	1	
14	5XG-E1531-00	GEAR, BALANCE WEIGHT	1	1	1	1	
15	5XG-E1454-00	WEIGHT 1	1	1	1	1	
16	93306-30427	BEARING	2	2	2	2	
17	90282-05013	KEY, STRAIGHT	1	1	1	1	
18	90215-14810	WASHER, LOCK	1	1	1	1	
19	90170-14839	NUT	1	1	1	1	
20	90280-05048	KEY, WOODRUFF	1	1	1	1	
21	90201-107F8	WASHER, PLATE	1	1	1	1	
22	92907-10100	WASHER, SPRING	1	1	1	1	
23	90101-10568	BOLT	1	1	1	1	

FIG. 3 CRANKSHAFT & PISTON



REF. NO.	PART NO.	DESCRIPTION	USA	CAN	EUR	OCE	REMARKS
24	93210-16800	O-RING	1	1	1	1	
25	99009-26400	CIRCLIP	1	1	1	1	
-----							
-----							
-----							
-----							
-----							
-----							
-----							
-----							
-----							

FIG. 4 VALVE



29U110-5040

REF. NO.	PART NO.	DESCRIPTION	USA	CAN	EUR	OCE	REMARKS
1	5XG-E2111-00	VALVE, INTAKE	1	1	1	1	
2	5XG-E2121-00	VALVE, EXHAUST	1	1	1	1	
3	4G0-12116-01	SEAT, VALVE SPRING	2	2	2	2	
4	4G0-12113-01	SPRING, VALVE INNER	2	2	2	2	YELLOW
5	4G0-12114-01	SPRING, VALVE OUTER	2	2	2	2	YELLOW
6	5H0-12119-00	SEAL, VALVE STEM	2	2	2	2	
7	4G0-12117-00	RETAINER, VALVE SPRING	2	2	2	2	
8	4G0-12118-00	COTTER, VALVE	4	4	4	4	
9	5XG-E2151-00	ARM, VALVE ROCKER	2	2	2	2	
10	3UR-E2156-00	SHAFT, ROCKER 2	1	1	1	1	
11	3UR-E2146-00	SHAFT, ROCKER	1	1	1	1	
12	93210-09165	O-RING	1	1	1	1	
13	2NX-12159-00	SCREW, VALVE ADJUSTING	2	2	2	2	
14	90170-06128	NUT	2	2	2	2	

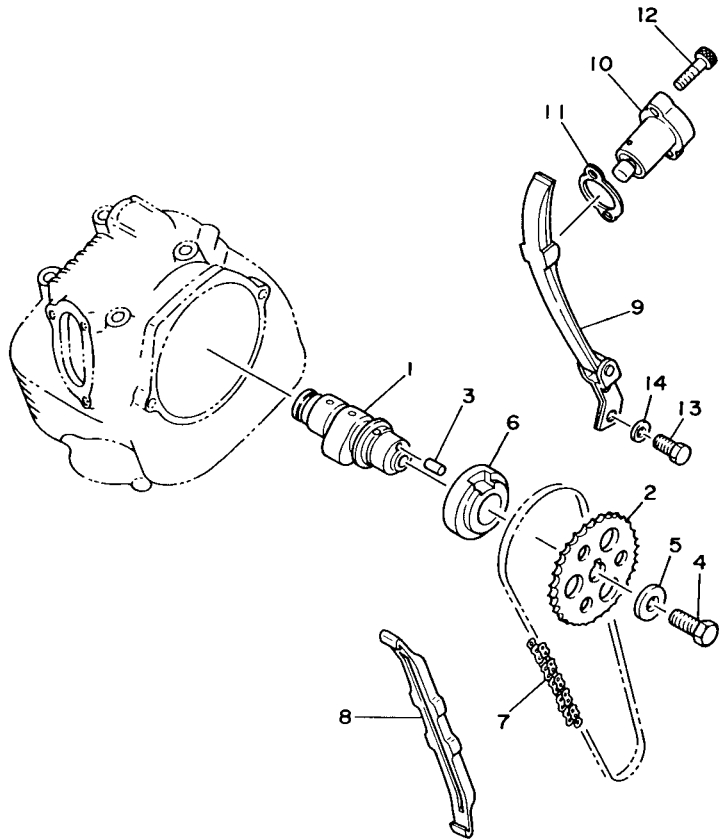
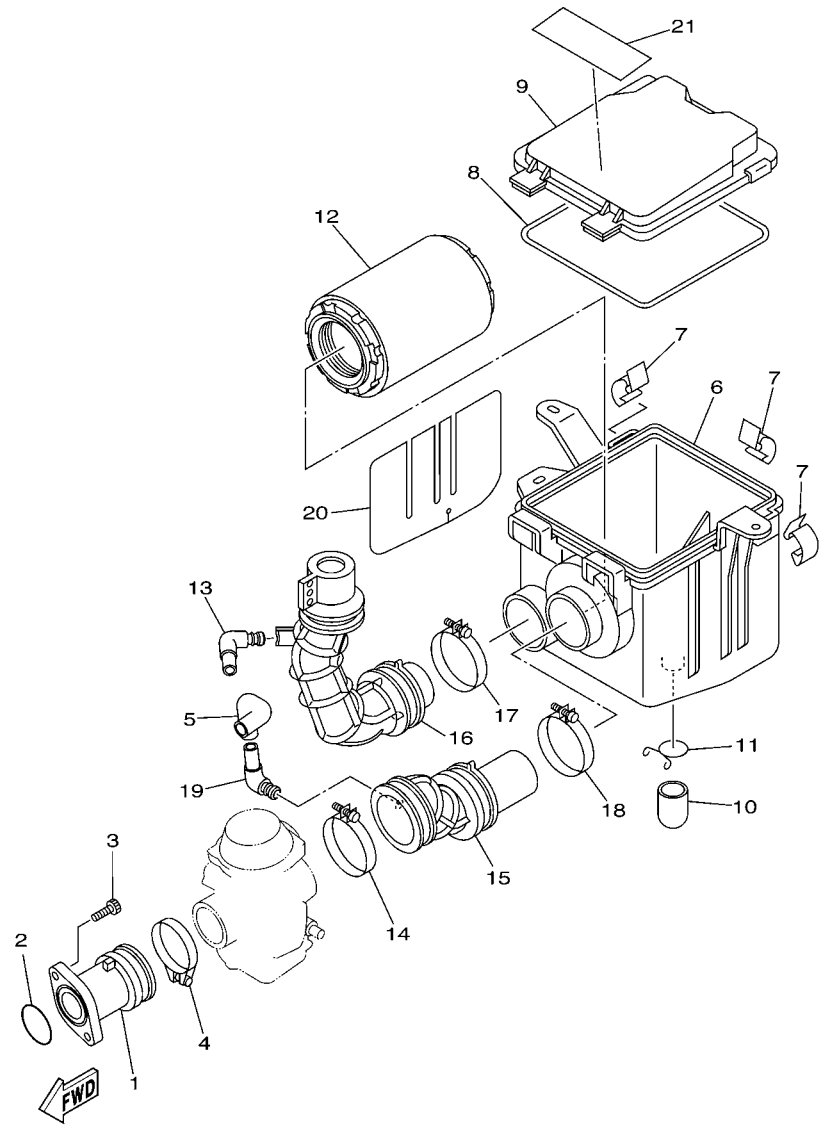


FIG. 5 CAMSHAFT & CHAIN

REF. NO.	PART NO.	DESCRIPTION	USA	CAN	EUR	OCE	REMARKS
1	5XG-E2171-00	CAMSHAFT 1	1	1	1	1	
2	5XG-E2176-00	SPROCKET, CAM CHAIN	1	1	1	1	
3	93604-10837	PIN, DOWEL	1	1	1	1	
4	90101-10303	BOLT	1	1	1	1	
5	90201-108C6	WASHER, PLATE	1	1	1	1	
6	90389-25800	BUSH	1	1	1	1	
7	94580-41104	CHAIN (DID25SH 104L)	1	1	1	1	
8	3UR-E2231-00	GUIDE, STOPPER 1	1	1	1	1	
9	5XG-E2241-00	GUIDE, STOPPER 2	1	1	1	1	
10	3GC-12210-10	TENSIONER ASSY, CAM CHAIN	1	1	1	1	
11	4FM-12213-00	GASKET, TENSIONER CASE	1	1	1	1	
12	95027-06025	BOLT, FLANGE	2	2	2	2	
13	97027-06016	BOLT	2	2	2	2	
14	92907-06600	WASHER, PLATE	2	2	2	2	



29U110-5050



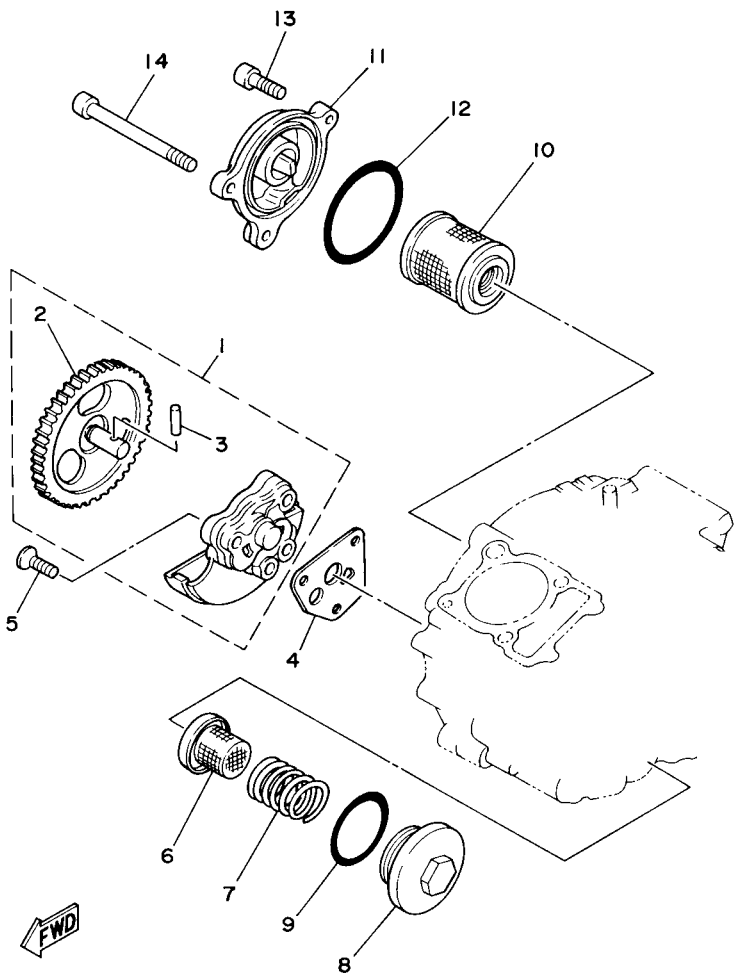
1P01100-D060

FIG. 6 INTAKE

REF. NO.	PART NO.	DESCRIPTION	USA	CAN	EUR	OCE	REMARKS
1	1P0-13586-00	JOINT, CARBURETOR 1	1	1	1	1	
2	93210-35895	O-RING	1	1	1	1	
3	91317-06020	BOLT	2	2	2	2	
4	90450-47001	HOSE CLAMP ASSY	1	1	1	1	
5	5UH-E4349-00	PIPE	1	1	1	1	
6	4XE-E4411-00	CASE, AIR CLEANER 1	1	1	1	1	
7	JN6-E4424-00	CLIP, CAP FITTING	3	3	3	3	
8	4XE-E4462-00	SEAL	1	1	1	1	
9	4XE-E4412-00	CAP, CLEANER CASE 1	1	1	1	1	
10	4XE-E4457-00	SEAL	1	1	1	1	
11	4XE-E4438-00	CLIP, DRAIN CLEANER	1	1	1	1	
12	4XE-E4450-00	ELEMENT ASSY, AIR CLEANER	1	1	1	1	
13	31A-14419-00	PIPE	1	1	1	1	
14	90450-56006	HOSE CLAMP ASSY	1	1	1	1	
15	1P0-E4453-00	JOINT, AIR CLEANER 1	1	1	1	1	
16	4XE-E4437-00	DUCT	1	1	1	1	
17	90460-58124	CLAMP, HOSE	1	1	1	1	
18	90450-56006	HOSE CLAMP ASSY	1	1	1	1	
19	31A-14419-00	PIPE	1	1	1	1	
20	4XE-E442F-00	PROTECTOR	1	1	1	1	
21	1P0-2177C-00	PLATE, EPA OFFROAD ATV 1	1				

FIG. 7 OIL PUMP

REF. NO.	PART NO.	DESCRIPTION	USA	CAN	EUR	OCE	REMARKS
1	5XG-E3300-00	OIL PUMP ASSY	1	1	1	1	
2	5XG-E3326-00	.GEAR, PUMP DRIVEN 2	1	1	1	1	
3	93603-12801	.PIN, DOWEL	1	1	1	1	
4	4BE-13329-01	GASKET, PUMP COVER	1	1	1	1	
5	98707-06030	SCREW, FLAT HEAD	3	3	3	3	
6	51Y-13411-00	STRAINER, OIL	1	1	1	1	
7	90501-18576	SPRING, COMPRESSION	1	1	1	1	
8	5XG-E5351-00	PLUG, DRAIN	1	1	1	1	
9	93210-34800	O-RING	1	1	1	1	
10	3UH-E3440-00	ELEMENT ASSY, OIL CLEANER	1	1	1	1	
11	5XG-E3447-00	COVER, OIL ELEMENT	1	1	1	1	
12	93210-548A1	O-RING	1	1	1	1	
13	91317-06020	BOLT	2	2	2	2	
14	91317-06115	BOLT	1	1	1	1	



4KDF100-8060



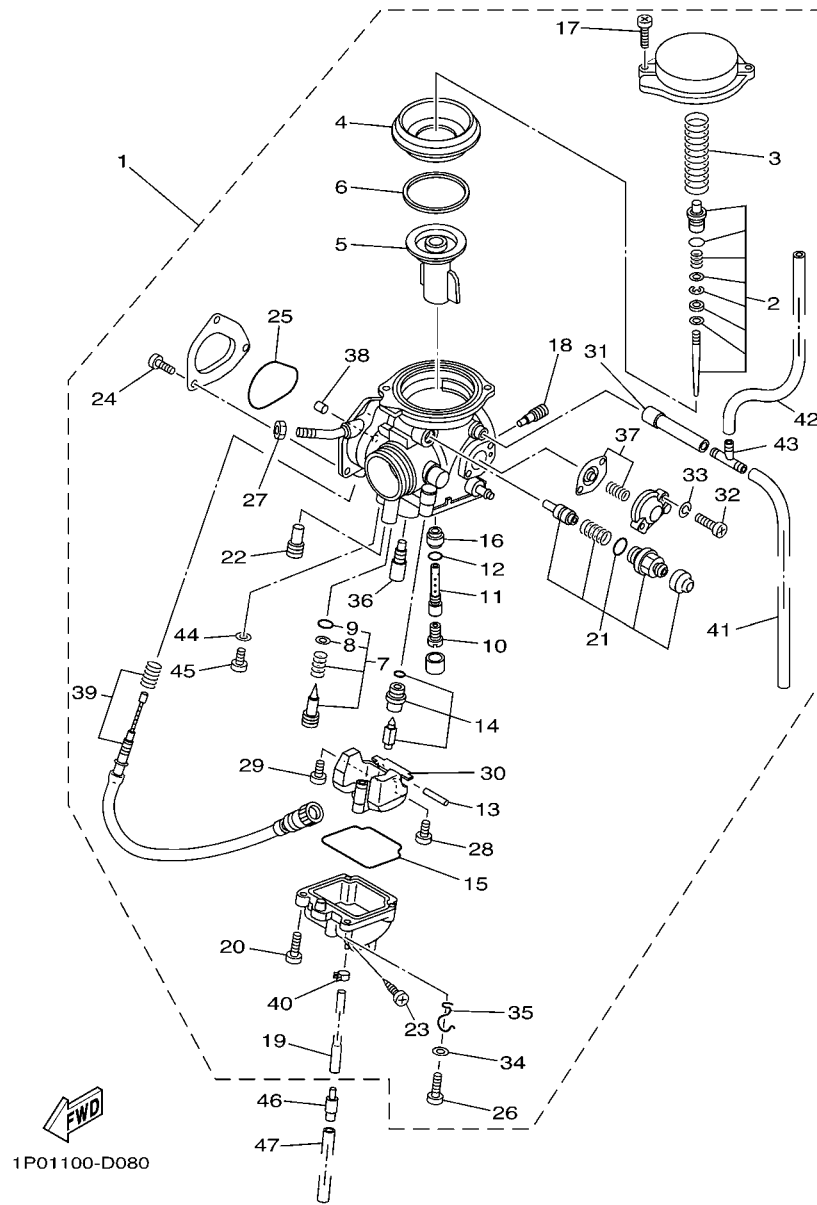
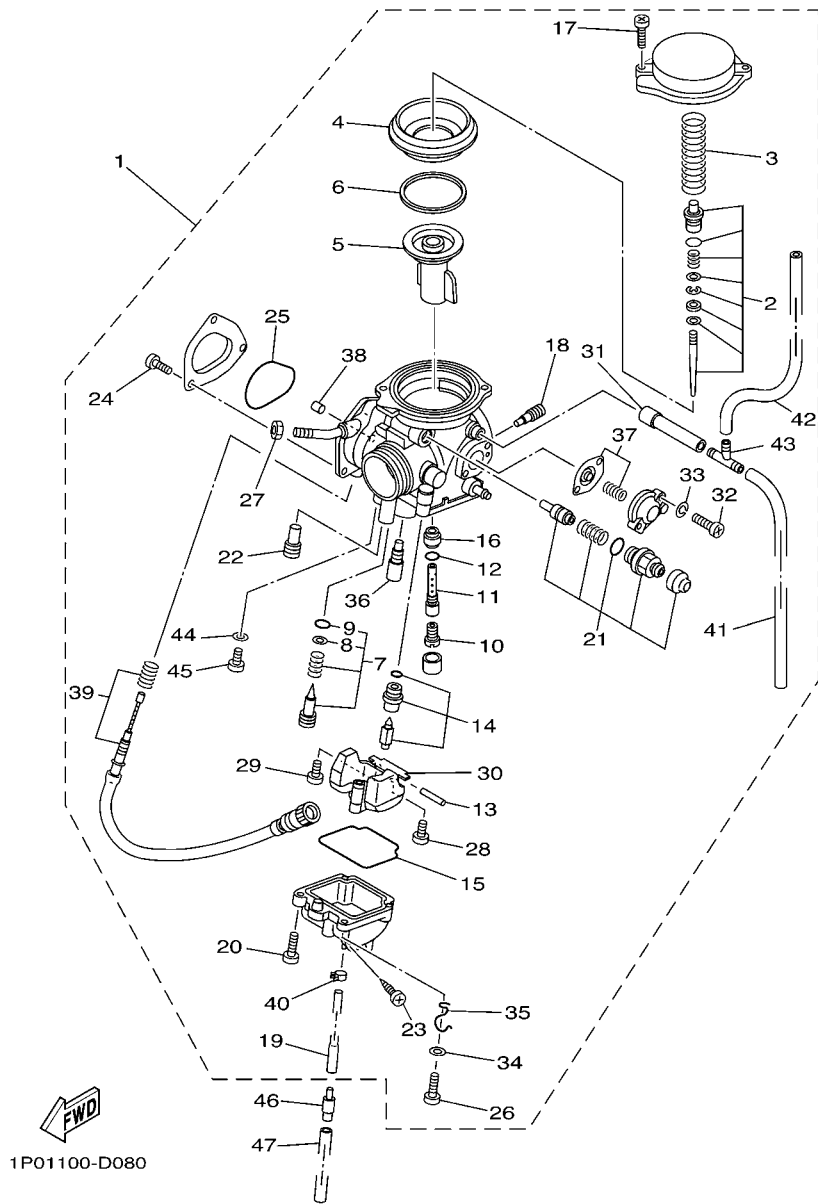


FIG. 8 CARBURETOR

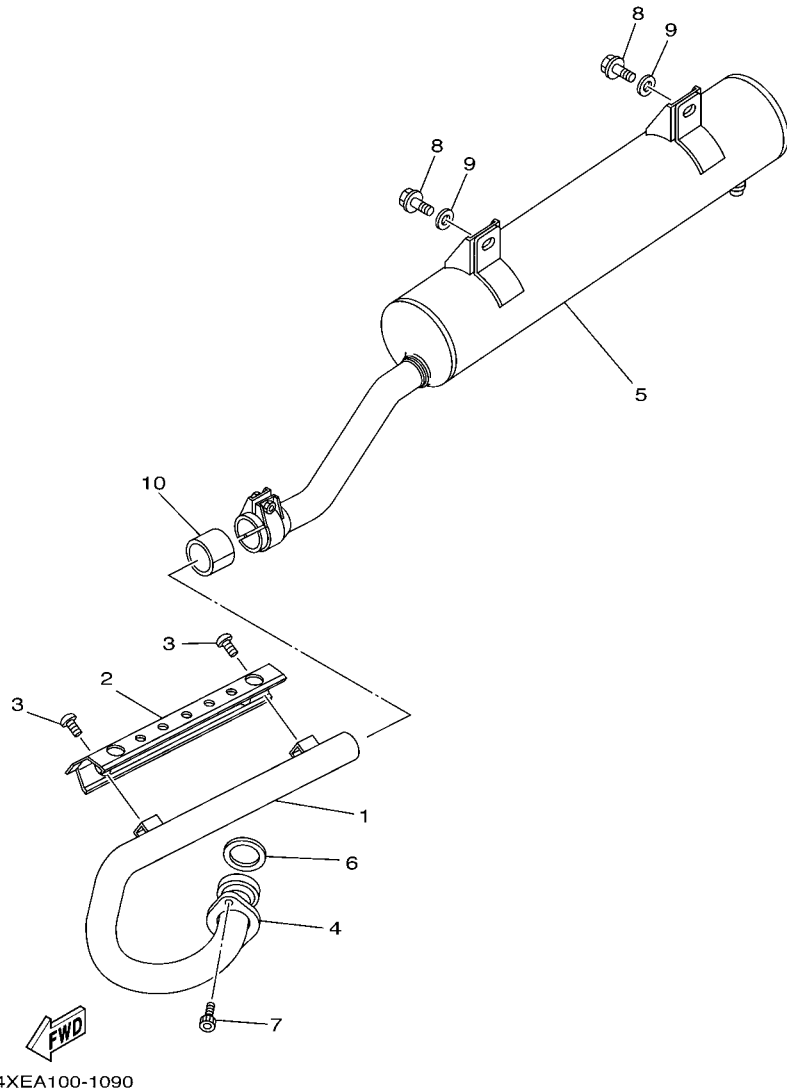
REF. NO.	PART NO.	DESCRIPTION	USA	CAN	EUR	OCE	REMARKS
1	1P0-E4101-10	CARBURETOR ASSY 1	1	1			
	1P0-E4101-01	CARBURETOR ASSY 1			1	1	
2	1P0-1490J-00	.NEEDLE SET	1	1	1	1	
3	5DM-14933-00	.SPRING, DIAPHRAGM	1	1	1	1	
4	5GH-14940-10	.DIAPHRAGM ASSY	1	1	1	1	
5	5DM-14112-00	.VALVE, THROTTLE 1	1	1	1	1	
6	5GH-14918-10	.RING	1	1	1	1	
7	5FU-14105-10	.PILOT SCREW SET	1	1	1	1	WHITE SPRING
8	3H1-14962-00	..WASHER	1	1	1	1	
9	3H1-14147-00	..O-RING	1	1	1	1	
10	3G2-1414E-37	.JET, MAIN (#93.8)	1	1	1	1	
11	5DM-14261-00	.HOLDER	1	1	1	1	
12	583-14561-00	.O-RING	1	1	1	1	
13	127-14186-00	.PIN, FLOAT	1	1	1	1	
14	1P0-14107-20	.NEEDLE VALVE SET	1	1			
	4KM-14107-20	.NEEDLE VALVE SET			1	1	
15	5DM-14561-00	.O-RING	1	1	1	1	
16	5DM-14141-42	.NOZZLE, MAIN	1	1	1	1	
17	4KM-14216-00	.SCREW	2	2	2	2	
18	1HX-14231-16	.JET, MAIN (# 80)	1	1	1	1	
19	4KB-14193-20	.PIPE	1	1	1	1	
20	98580-04010	.SCREW, PAN HEAD	3	3	3	3	
21	5UH-1410A-00	.STARTER SET	1	1	1	1	
22	3G2-14231-12	.JET, POWER (# 60)	1	1	1	1	
23	3FV-14191-00	.PLUG, DRAIN	1	1	1	1	
24	98507-04006	.SCREW, PAN HEAD	3	3	3	3	
25	5FU-E4147-00	.O-RING	1	1	1	1	



**FIG. 8 CARBURETOR**

REF. NO.	PART NO.	DESCRIPTION	USA	CAN	EUR	OCE	REMARKS
26	98507-04014	.SCREW, PAN HEAD	1	1	1	1	
27	522-14161-00	.NUT, CABLE ADJUSTING	1	1	1	1	
28	98507-04008	.SCREW, PAN HEAD	1	1	1	1	
29	1FN-14565-00	.SCREW	1	1	1	1	
30	5DM-14985-00	.FLOAT	1	1	1	1	
31	5FU-14197-00	.PIPE	1	1	1	1	
32	98501-04014	.SCREW, PAN HEAD	2	2	2	2	
33	92902-04100	.WASHER, SPRING	2	2	2	2	
34	92907-04600	.WASHER	1	1	1	1	
35	5GH-14937-00	.CLIP	1	1	1	1	
36	4KM-14142-17	.JET, PILOT (# 17.5)	1	1	1	1	
37	5EL-1490H-00	.DIAPHRAGM SET 5	1	1			
	5ND-1490H-00	.DIAPHRAGM SET 5			1	1	
38	5FU-E4155-00	.GUIDE, CABLE	1	1	1	1	
39	5UH-14103-00	.THROTTLE SCREW SET	1	1	1	1	
40	4XE-14937-00	.CLIP	1	1	1	1	
41	5UH-14348-00	.PIPE 1	1	1	1	1	
42	7T9-14987-00	.HOSE	1	1	1	1	
43	5FU-14167-00	.CONNECTOR	1	1	1	1	
44	256-14956-01	.WASHER	1	1	1	1	
45	3DM-14216-00	.SCREW	1	1	1	1	
46	24W-14193-00	PIPE	1	1	1	1	
47	91A20-07010	TUBE, FLEXIBLE VINYL	1	1	1	1	

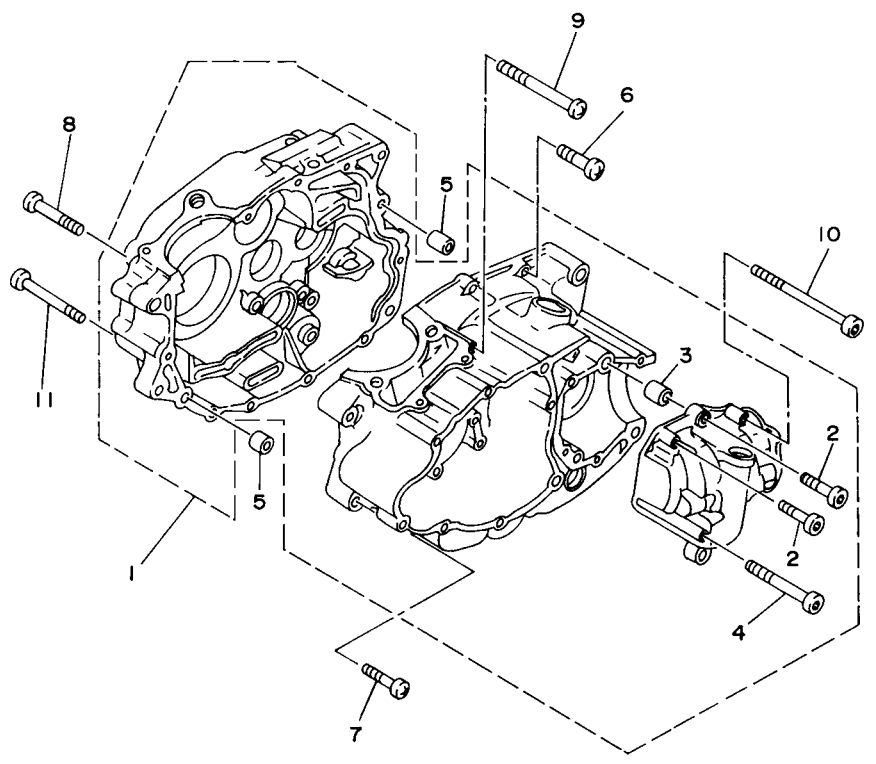
FIG. 9 EXHAUST



REF. NO.	PART NO.	DESCRIPTION	USA	CAN	EUR	OCE	REMARKS
1	4XE-E4611-10	PIPE, EXHAUST 1	1	1	1	1	
2	4XE-E4628-00	PROTECTOR, EXHAUST PIPE	1	1	1	1	
3	4XE-E4767-00	SCREW	2	2	2	2	
4	4XE-E4612-10	NUT, RING	1	1	1	1	
5	4XE-E4710-20	MUFFLER ASSY 1	1	1	1	1	
6	4BE-14613-00	GASKET, EXHAUST PIPE	1	1	1	1	
7	9131P-06020	BOLT	2	2	2	2	
8	90105-10801	BOLT, FLANGE	2	2	2	2	
9	90201-101J1	WASHER, PLATE	2	2	2	2	
10	3YF-14714-00	GASKET, MUFFLER	1	1	1	1	

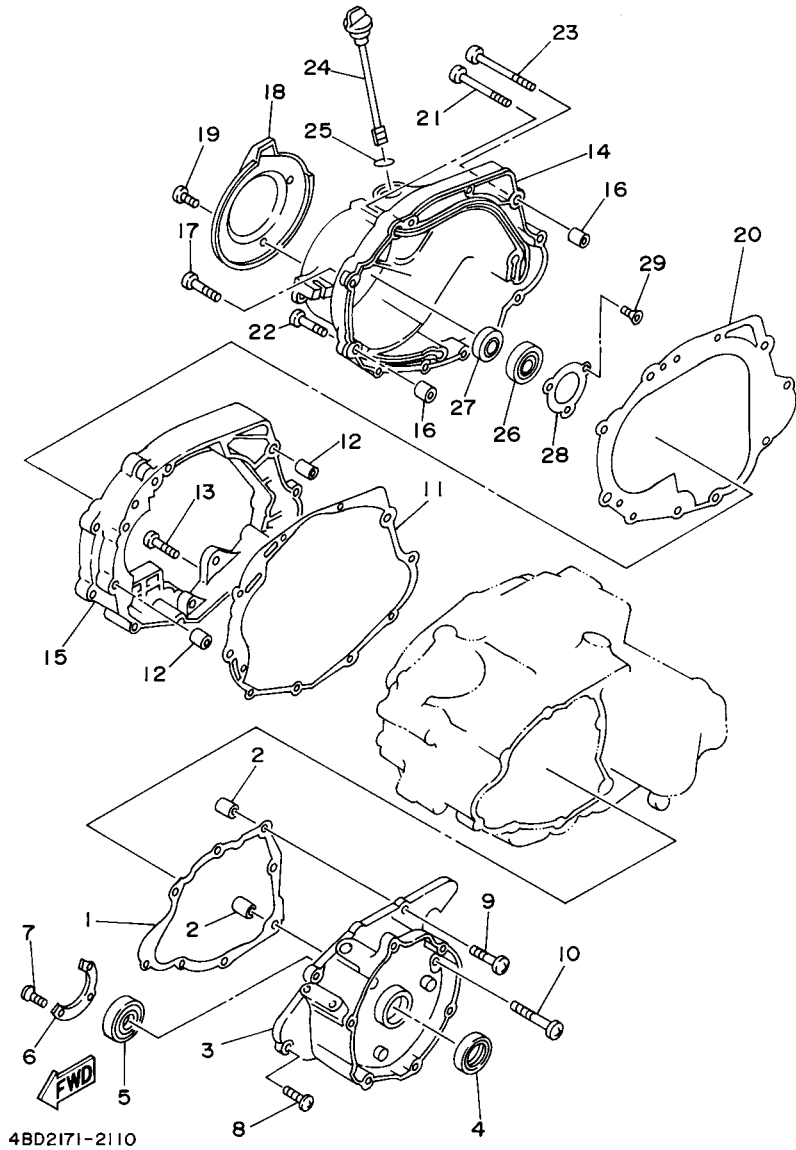
FIG. 10 CRANKCASE

REF. NO.	PART NO.	DESCRIPTION	USA	CAN	EUR	OCE	REMARKS
1	5XG-E5150-00	CRANKCASE ASSY	1	1	1	1	
2	91317-06035	.BOLT	4	4	4	4	
3	99530-10014	.PIN, DOWEL	2	2	2	2	
4	91317-06085	.BOLT	1	1	1	1	
5	91812-16805	PIN, DOWEL	2	2	2	2	
6	98507-06030	SCREW, PAN HEAD	7	7	7	7	
7	98507-06040	SCREW, PAN HEAD	1	1	1	1	
8	98507-06060	SCREW, PAN HEAD	1	1	1	1	
9	98507-06085	SCREW, PAN HEAD	1	1	1	1	
10	90110-06817	BOLT, HEXAGON SOCKET HEAD	1	1	1	1	
11	98507-06075	SCREW, PAN HEAD	1	1	1	1	



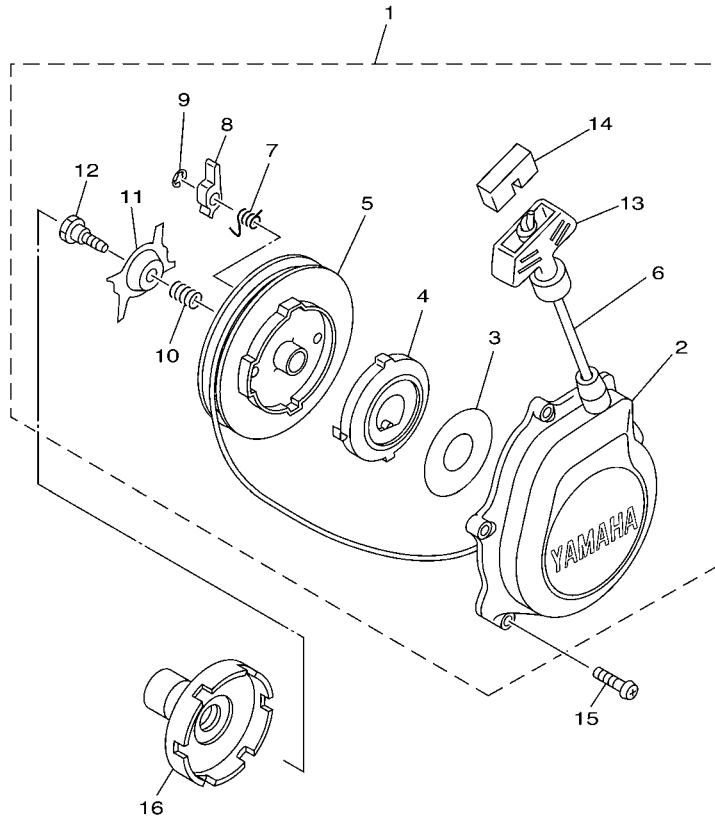
1P09100-F100

FIG. 11 CRANKCASE COVER 1



REF. NO.	PART NO.	DESCRIPTION	USA	CAN	EUR	OCE	REMARKS
1	4BD-15451-01	GASKET, CRANKCASE COVER 1	1	1	1	1	
2	91812-16805	PIN, DOWEL	2	2	2	2	
3	5XG-E5787-00	ADAPTOR	1	1	1	1	
4	93103-28141	OIL SEAL	1	1	1	1	
5	93306-078Y0	BEARING	1	1	1	1	
6	21V-15719-00	WASHER, THRUST	1	1	1	1	
7	98707-05016	SCREW, FLAT HEAD	3	3	3	3	
8	98507-06025	SCREW, PAN HEAD	5	5	5	5	
9	98507-06040	SCREW, PAN HEAD	2	2	2	2	
10	98507-06060	SCREW, PAN HEAD	1	1	1	1	
11	4BD-15462-00	GASKET, CRANKCASE COVER 3	1	1	1	1	
12	91812-16805	PIN, DOWEL	2	2	2	2	
13	98507-06040	SCREW, PAN HEAD	3	3	3	3	
14	5XG-E5431-00	COVER, CRANKCASE 3	1	1	1	1	
15	5XG-E5317-00	SPACER, ENGINE MOUNT	1	1	1	1	
16	91812-16805	PIN, DOWEL	2	2	2	2	
17	98507-06040	SCREW, PAN HEAD	2	2	2	2	
18	5XG-E5499-00	PROTECTOR, COVER	1	1	1	1	
19	98907-06014	SCREW, BIND	3	3	3	3	
20	4BD-15463-01	GASKET, COVER PINION 2	1	1	1	1	
21	98507-06070	SCREW, PAN HEAD	5	5	5	5	
22	98507-06040	SCREW, PAN HEAD	1	1	1	1	
23	98507-06080	SCREW, PAN HEAD	1	1	1	1	
24	5XG-E5362-00	PLUG, OIL LEVEL	1	1	1	1	
25	93210-19841	O-RING	1	1	1	1	
26	93306-203X0	BEARING	1	1	1	1	
27	93101-17113	OIL SEAL	1	1	1	1	



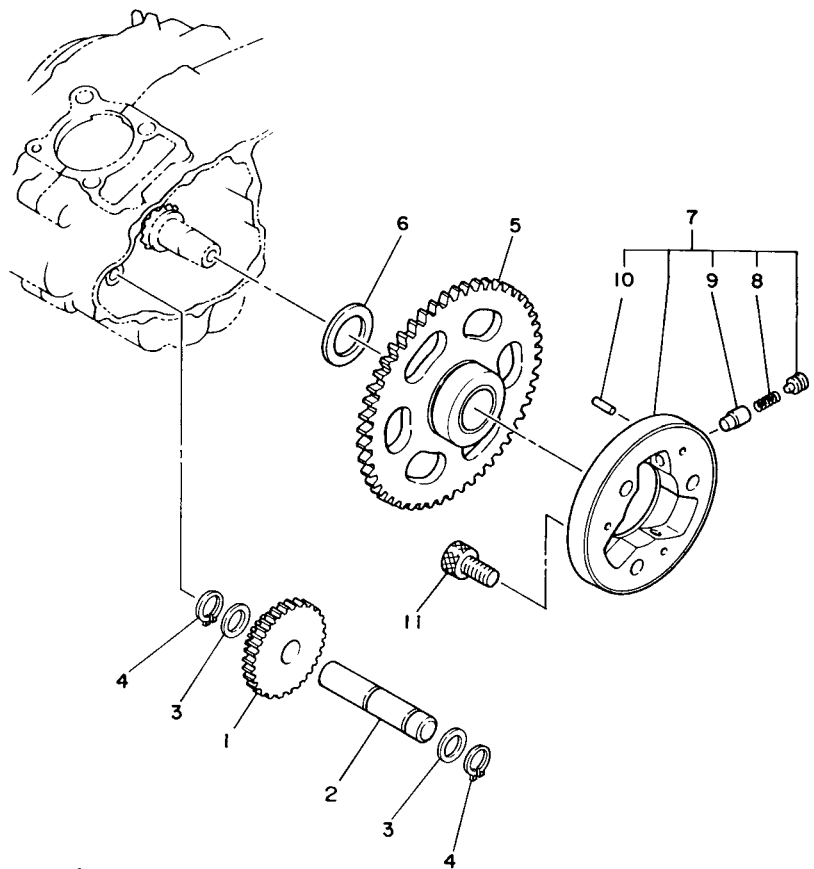


4XE1110-9120

FIG. 12 STARTER

REF. NO.	PART NO.	DESCRIPTION	USA	CAN	EUR	OCE	REMARKS
1	4XE-E5710-00	STARTER ASSY	1	1	1	1	
2	4XE-E5711-00	.CASE, STARTER	1	1	1	1	
3	4XE-E5789-00	.DAMPER	1	1	1	1	
4	4XE-E5713-00	.SPRING, STARTER	1	1	1	1	
5	4XE-E5714-00	.DRUM, SHEAVE	1	1	1	1	
6	4XE-E5751-00	.WIRE, STARTER	1	1	1	1	
7	4XE-E5767-00	.SPRING	2	2	2	2	
8	4XE-E5741-00	.PAWL, DRIVE	2	2	2	2	
9	4XE-E5744-00	.CIRCLIP	2	2	2	2	
10	4XE-E5715-00	.SPRING, FRICTION	1	1	1	1	
11	4XE-E5716-00	.PLATE, DRIVE	1	1	1	1	
12	4XE-E5793-00	.SCREW	1	1	1	1	
13	4XE-E5755-00	.HANDLE, STARTER	1	1	1	1	
14	4XE-E5779-00	.COVER	1	1	1	1	
15	98507-06020	SCREW, PAN HEAD	6	6	6	6	
16	5XG-E5723-00	PULLEY, STARTER	1	1	1	1	

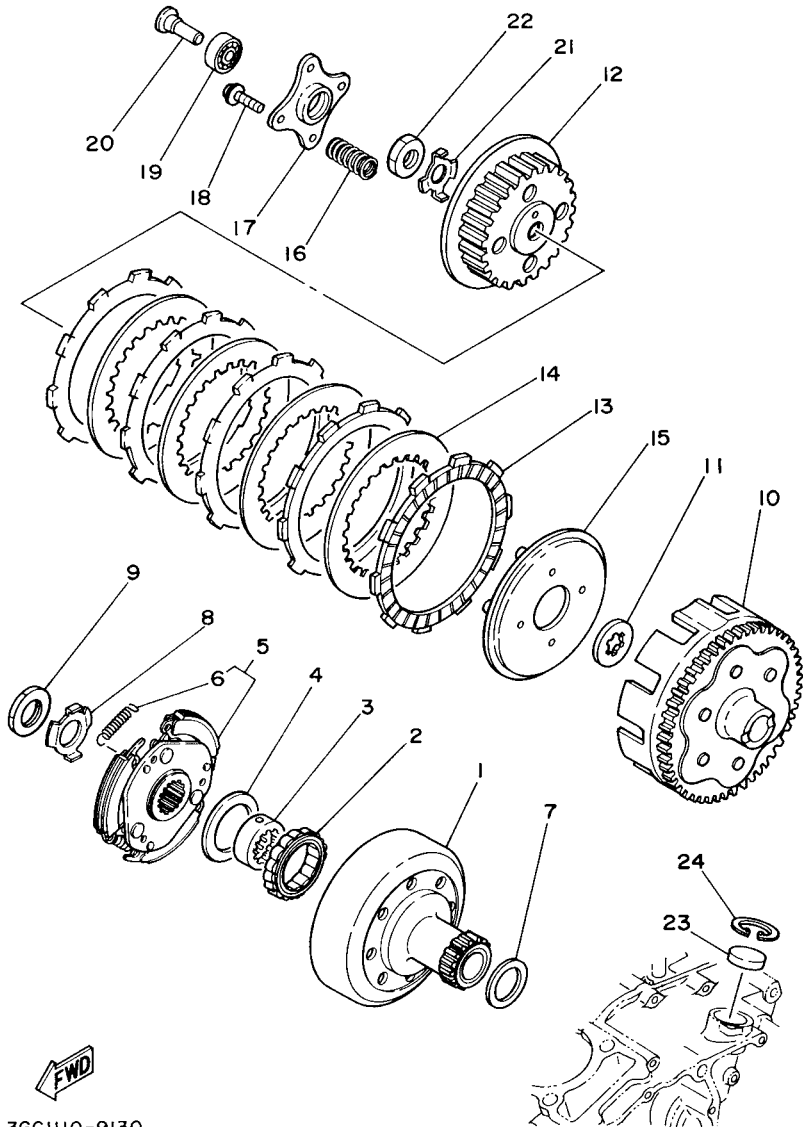
FIG. 13 STARTER CLUTCH



REF. NO.	PART NO.	DESCRIPTION	USA	CAN	EUR	OCE	REMARKS
1	1P0-E5512-00	GEAR, IDLER 1	1	1	1	1	
2	5XG-E5521-00	SHAFT 1	1	1	1	1	
3	90201-128C9	WASHER, PLATE	2	2	2	2	
4	99009-12400	CIRCLIP	2	2	2	2	
5	5XG-E5517-00	GEAR, IDLER 2	1	1	1	1	
6	90201-25290	WASHER, PLATE	1	1	1	1	
7	31A-15580-00	STARTER CLUTCH OUTER ASSY	1	1	1	1	
8	90501-04503	.SPRING, COMPRESSION	3	3	3	3	
9	1J7-15583-01	.CAP, STARTER CLUTCH SPRING	3	3	3	3	
10	93615-12088	.PIN, DOWEL	3	3	3	3	
11	91317-08016	BOLT	3	3	3	3	

FWD  
2HT110-7120





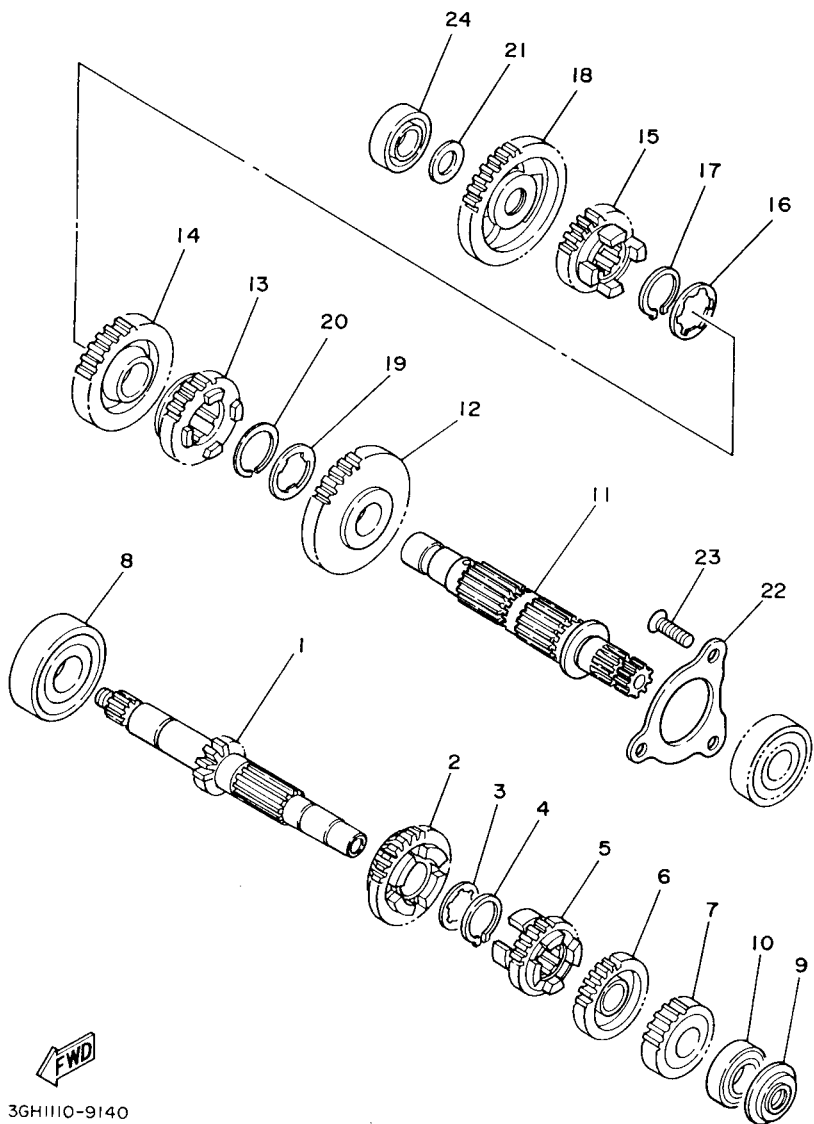
3GC1110-9130

FIG. 14 CLUTCH

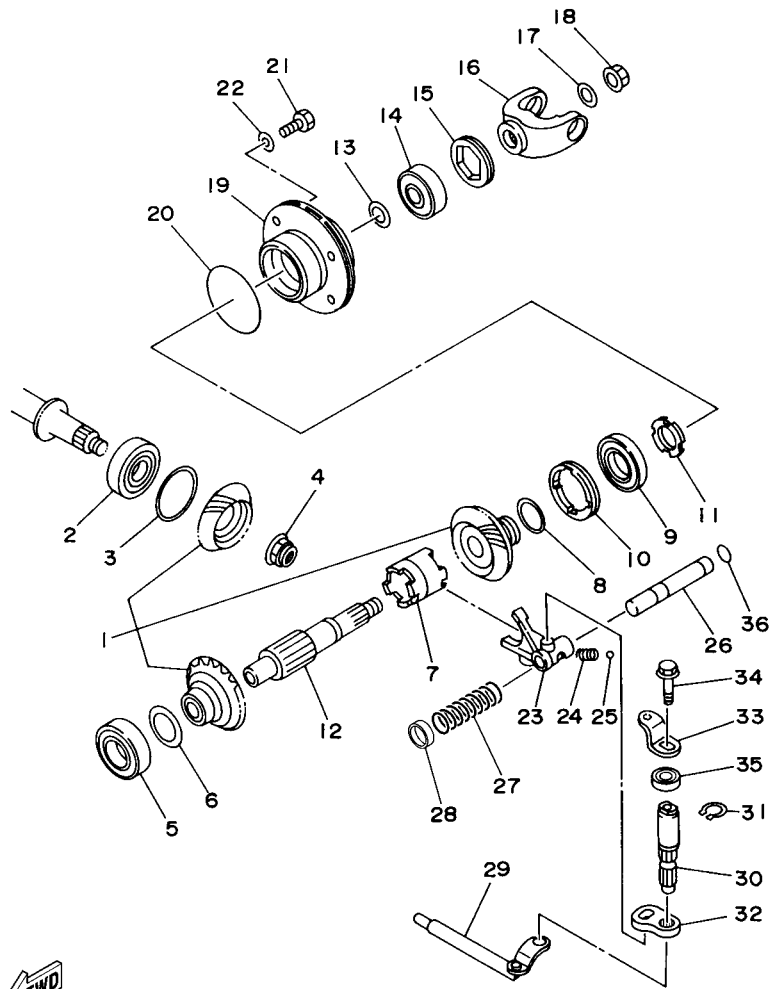
REF. NO.	PART NO.	DESCRIPTION	USA	CAN	EUR	OCE	REMARKS
1	5XG-E6611-00	CLUTCH HOUSING COMP.	1	1	1	1	
2	21V-16664-00	BEARING, ONE WAY	1	1	1	1	
3	5XG-E6665-00	RETAINER, BEARING	1	1	1	1	
4	90201-404M6	WASHER, PLATE	1	1	1	1	
5	5XG-E6620-00	CLUTCH CARRIER ASSY	1	1	1	1	
6	5XG-E6626-00	.SPRING, CLUTCH WEIGHT 1	3	3	3	3	
7	90201-266F6	WASHER, PLATE	1	1	1	1	
8	90215-22259	WASHER, LOCK	1	1	1	1	
9	90170-22371	NUT	1	1	1	1	
10	5XG-E6150-00	PRIMARY DRIVEN GEAR COMP.	1	1	1	1	
11	5XG-E6154-00	PLATE, THRUST 1	1	1	1	1	
12	5XG-E6371-00	BOSS, CLUTCH	1	1	1	1	
13	5XG-E6321-00	PLATE, FRICTION	5	5	5	5	
14	5XG-E6324-00	PLATE, CLUTCH 1	4	4	4	4	
15	5XG-E6351-00	PLATE, PRESSURE 1	1	1	1	1	
16	90501-243J7	SPRING, COMPRESSION	4	4	4	4	
17	5XG-E6352-00	PLATE, PRESSURE 2	1	1	1	1	
18	90159-05011	SCREW, WITH WASHER	4	4	4	4	
19	93306-00006	BEARING	1	1	1	1	
20	21V-16358-00	PLATE, PUSH	1	1	1	1	
21	90215-14186	WASHER, LOCK	1	1	1	1	
22	90170-14839	NUT	1	1	1	1	
23	90338-26136	PLUG	1	1	1	1	
24	93420-28055	CIRCLIP	1	1	1	1	

FIG. 15 TRANSMISSION

REF. NO.	PART NO.	DESCRIPTION	USA	CAN	EUR	OCE	REMARKS
1	5XG-E7401-00	MAIN AXLE ASSY	1	1	1	1	
2	24W-17151-02	GEAR, 5TH PINION (28T)	1	1	1	1	
3	90209-17285	WASHER	1	1	1	1	
4	93410-20038	CIRCLIP	1	1	1	1	
5	5XG-E7131-00	GEAR, 3RD PINION (22T)	1	1	1	1	
6	5XG-E7141-00	GEAR, 4TH PINION (25T)	1	1	1	1	
7	5XG-E7121-00	GEAR, 2ND PINION (19T)	1	1	1	1	
8	93306-204Y6	BEARING	1	1	1	1	
9	93101-15101	OIL SEAL	1	1	1	1	
10	93306-202X2	BEARING	1	1	1	1	
11	5XG-E7402-00	DRIVE AXLE ASSY	1	1	1	1	
12	5XG-E7221-00	GEAR, 2ND WHEEL (34T)	1	1	1	1	
13	1P0-E7241-00	GEAR, 4TH WHEEL (26T)	1	1	1	1	
14	5XG-E7231-00	GEAR, 3RD WHEEL (29T)	1	1	1	1	
15	4BD-17251-00	GEAR, 5TH WHEEL (23T)	1	1	1	1	
16	90209-18208	WASHER	1	1	1	1	
17	93410-22039	CIRCLIP	1	1	1	1	
18	5XG-E7211-00	GEAR, 1ST WHEEL (34T)	1	1	1	1	
19	90209-23241	WASHER	1	1	1	1	
20	93410-26067	CIRCLIP	1	1	1	1	
21	90201-15700	WASHER, PLATE	1	1	1	1	
22	5XG-E7558-00	PLATE, BEARING	1	1	1	1	
23	90149-08152	SCREW	3	3	3	3	
24	93306-202X2	BEARING	1	1	1	1	



3GH1110-9140

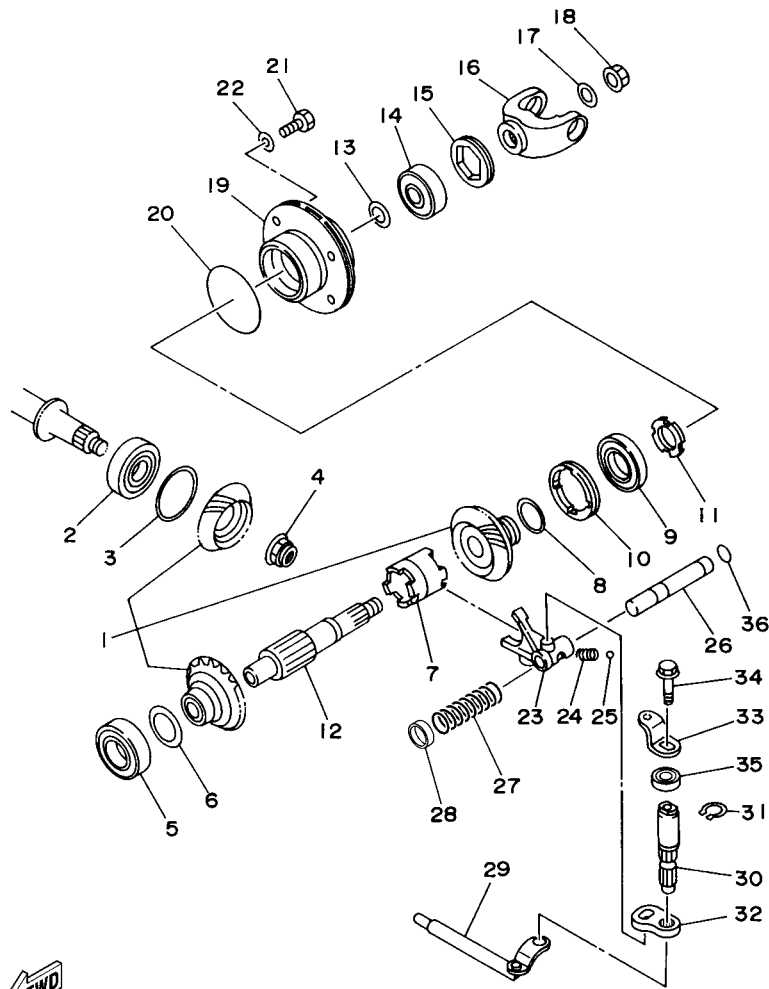


1P01100-D160

FIG. 16 MIDDLE DRIVE GEAR

REF. NO.	PART NO.	DESCRIPTION	USA	CAN	EUR	OCE	REMARKS
1	52G-Y1754-00	MIDDLE GEAR COMP.	1	1	1	1	
2	93306-304YE	BEARING	1	1	1	1	
3	24W-17537-10	SHIM, THRUST (0.13T)	1	1	1	1	UR
	24W-17537-20	SHIM, THRUST (0.15T)	1	1	1	1	UR
	24W-17537-30	SHIM, THRUST (0.2T)	1	1	1	1	UR
	24W-17537-40	SHIM, THRUST (0.3T)	1	1	1	1	UR
	24W-17537-50	SHIM, THRUST (0.4T)	1	1	1	1	UR
	24W-17537-60	SHIM, THRUST (0.5T)	1	1	1	1	UR
4	90179-16651	NUT	1	1	1	1	
5	93306-006Y3	BEARING	1	1	1	1	
6	52G-17531-01	SHIM, PINION (0.1T)	1	1	1	1	UR
	52G-17531-11	SHIM, PINION (0.15T)	1	1	1	1	UR
	52G-17531-21	SHIM, PINION (0.2T)	1	1	1	1	UR
	52G-17531-31	SHIM, PINION (0.3T)	1	1	1	1	UR
	52G-17531-41	SHIM, PINION (0.4T)	1	1	1	1	UR
	52G-17531-51	SHIM, PINION (0.5T)	1	1	1	1	UR
7	5XG-E7285-00	CLUTCH, DOG	1	1	1	1	
8	52G-17967-20	SHIM, (0.15T)	1	1	1	1	UR
	52G-17967-30	SHIM, (0.2T)	1	1	1	1	UR
	52G-17967-40	SHIM, (0.3T)	1	1	1	1	UR
9	93306-078Y0	BEARING	1	1	1	1	
10	90179-55464	NUT	1	1	1	1	
11	90179-28465	NUT	1	1	1	1	
12	5XG-E7553-00	SHAFT, MIDDLE DRIVEN	1	1	1	1	
13	5XG-E7968-00	SHIM, (1.0T)	1	1	1	1	UR
	5XG-E7968-10	SHIM, (1.1T)	1	1	1	1	UR
	5XG-E7968-20	SHIM, (1.2T)	1	1	1	1	UR

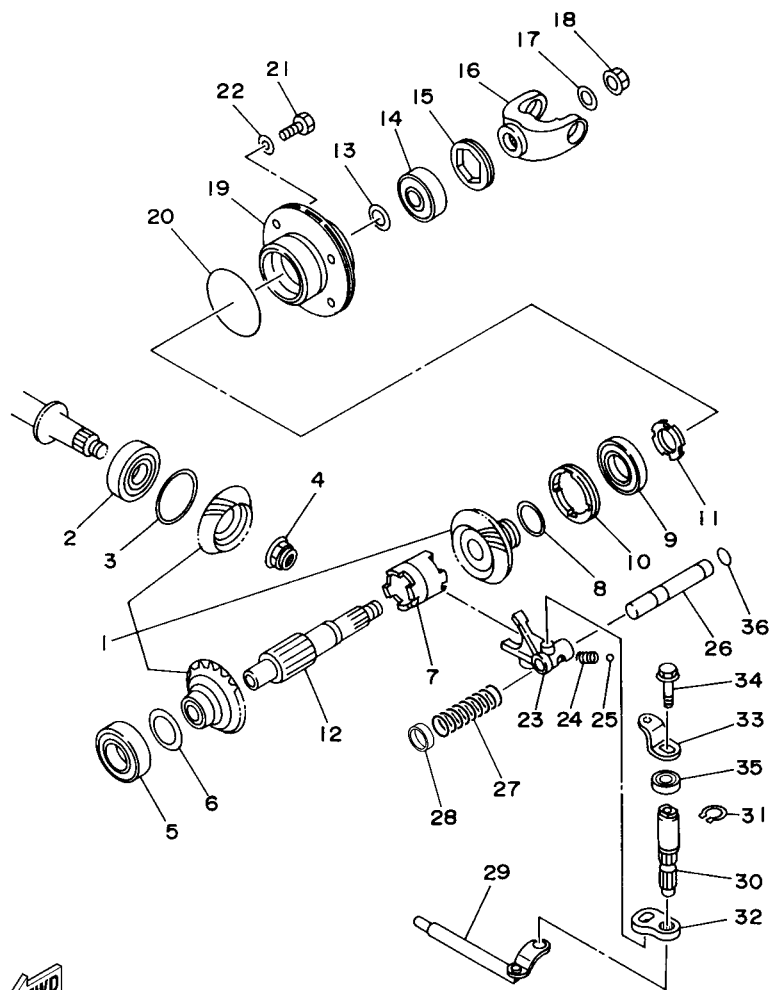
FIG. 16 MIDDLE DRIVE GEAR



1P01100-D160

REF. NO.	PART NO.	DESCRIPTION	USA	CAN	EUR	OCE	REMARKS
13	5XG-E7968-30	SHIM, (1.3T)	1	1	1	1	UR
	5XG-E7968-40	SHIM, (1.4T)	1	1	1	1	UR
	5XG-E7968-50	SHIM, (1.5T)	1	1	1	1	UR
	5XG-E7968-60	SHIM, (1.6T)	1	1	1	1	UR
	5XG-E7968-70	SHIM, (1.7T)	1	1	1	1	UR
	5XG-E7968-80	SHIM, (1.8T)	1	1	1	1	UR
	5XG-E7968-90	SHIM, (1.9T)	1	1	1	1	UR
14	93399-99917	BEARING	1	1	1	1	
15	1P0-E7642-00	NUT, BEARING	1	1	1	1	
16	5XG-E7556-00	YOKE, JOINT	1	1	1	1	
17	90201-125F7	WASHER, PLATE	1	1	1	1	
18	90179-12248	NUT	1	1	1	1	
19	5XG-E7551-00	HOUSING, BEARING	1	1	1	1	
20	93210-53800	O-RING	1	1	1	1	
21	97027-08025	BOLT	4	4	4	4	
22	92907-08600	WASHER, PLATE	4	4	4	4	
23	5XG-E8514-00	FORK, SHIFT 4	1	1	1	1	
24	90501-101A5	SPRING, COMPRESSION	1	1	1	1	
25	93501-04805	BALL	1	1	1	1	
26	5XG-E8534-00	BAR, SHIFT FORK GUIDE	1	1	1	1	
27	90501-13800	SPRING, COMPRESSION	1	1	1	1	
28	1P0-E8323-00	CAP, SPRING	1	1	1	1	
29	5XG-E812A-00	STOPPER SHAFT ASSY	1	1	1	1	
30	5XG-E8197-00	SHAFT	1	1	1	1	
31	99009-14400	CIRCLIP	1	1	1	1	
32	5XG-E8451-00	LEVER, SHIFT	1	1	1	1	
33	5XG-E8198-00	LEVER	1	1	1	1	

FIG. 16 MIDDLE DRIVE GEAR

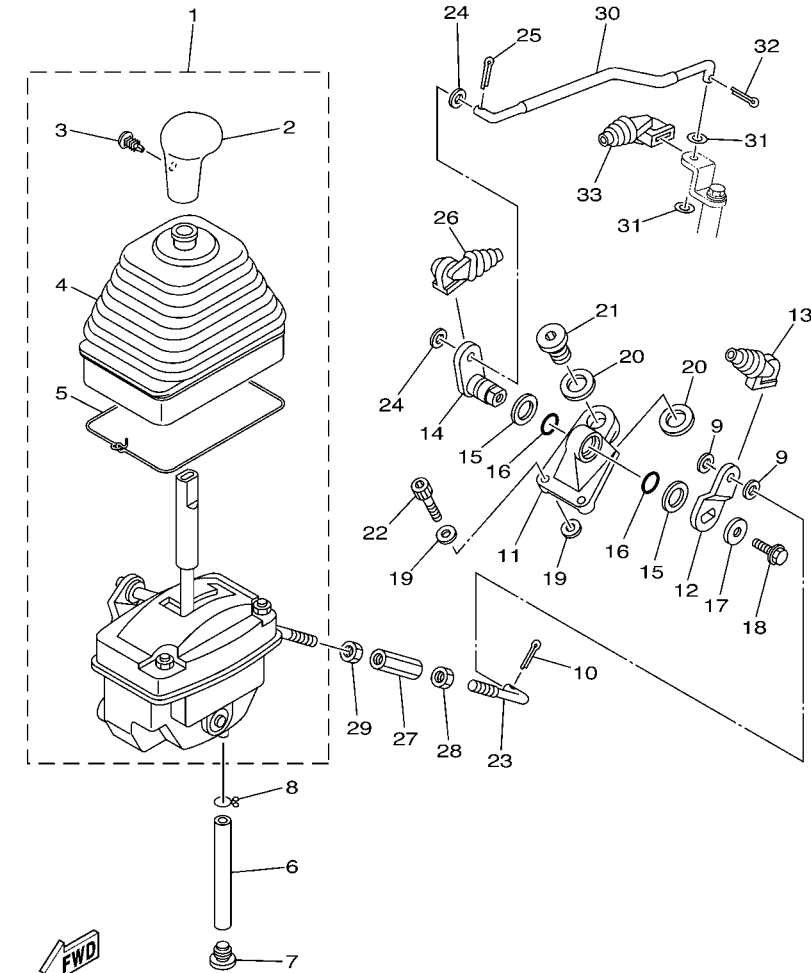


REF. NO.	PART NO.	DESCRIPTION	USA	CAN	EUR	OCE	REMARKS
34	95817-06016	BOLT, FLANGE	1	1	1	1	
35	93102-14856	OIL SEAL	1	1	1	1	
36	93210-09165	O-RING	1	1	1	1	



1P01100-D160

FIG. 17 DRIVE SELECTOR



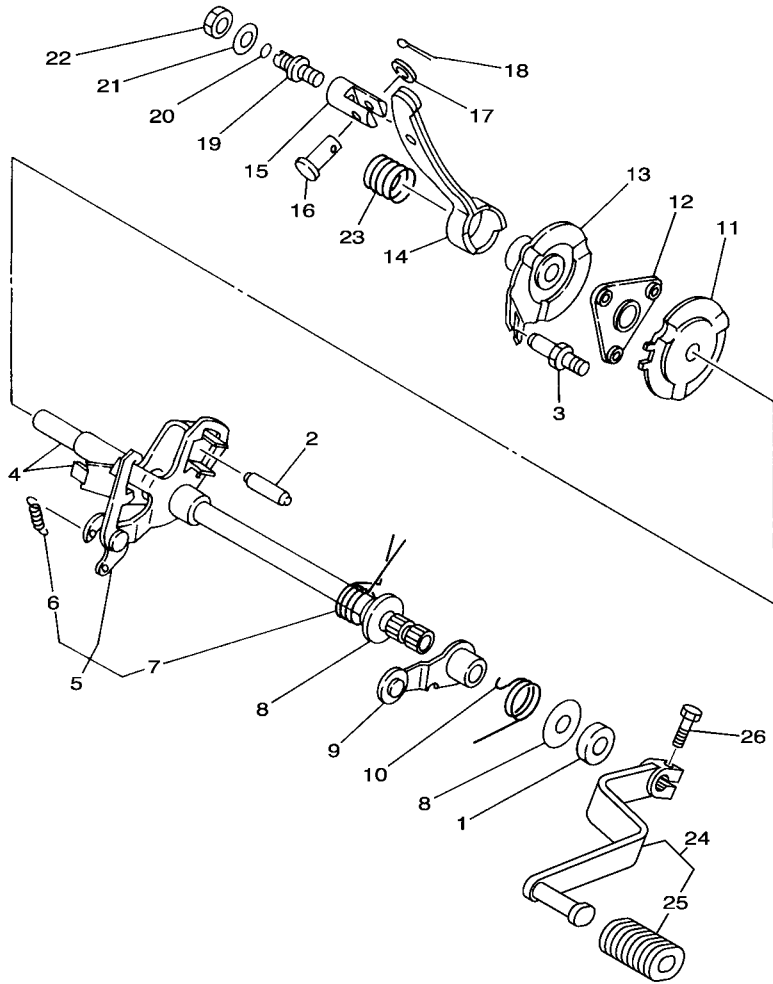
1P05100-E170

REF. NO.	PART NO.	DESCRIPTION	USA	CAN	EUR	OCE	REMARKS
1	1P0-18300-01	SHIFTER ASSY	1	1	1	1	
2	1P0-18174-00	.KNOB, SHIFT LEVER	1	1	1	1	
3	90269-05055	.RIVET	1	1	1	1	
4	5GH-18131-00	.BOOT, SEALING	1	1	1	1	
5	5GH-18617-00	.STOPPER,RUBBER	1	1	1	1	
6	90446-16001	HOSE (L90)	1	1	1	1	
7	5ND-E4191-00	PLUG, DRAIN	1	1	1	1	
8	90467-15012	CLIP	1	1	1	1	
9	92907-06200	WASHER	2	2	2	2	
10	91401-20015	PIN, COTTER	1	1	1	1	
11	1P0-E8164-00	KNOB, SHIFTER	1	1	1	1	
12	1P0-E8191-00	LEVER	1	1	1	1	
13	5XG-E8154-10	COVER, DUST	1	1	1	1	
14	1P0-E8341-00	SHAFT, RINK	1	1	1	1	
15	90201-144J2	WASHER, PLATE	2	2	2	2	
16	93210-14805	O-RING	2	2	2	2	
17	90201-06008	WASHER, PLATE	1	1	1	1	
18	95817-06016	BOLT, FLANGE	1	1	1	1	
19	90201-067P3	WASHER, PLATE	4	4	4	4	
20	90201-147P2	WASHER, PLATE	2	2	2	2	
21	90340-14107	PLUG, STRAIGHT SCREW	1	1	1	1	
22	91317-06020	BOLT	2	2	2	2	
23	5XG-E8117-00	JOINT, ROD 2	1	1	1	1	
24	92907-06200	WASHER	2	2	2	2	
25	91401-20015	PIN, COTTER	1	1	1	1	
26	5XG-E8154-00	COVER, DUST	1	1	1	1	
27	52G-18187-00	NUT, ADJUST	1	1	1	1	





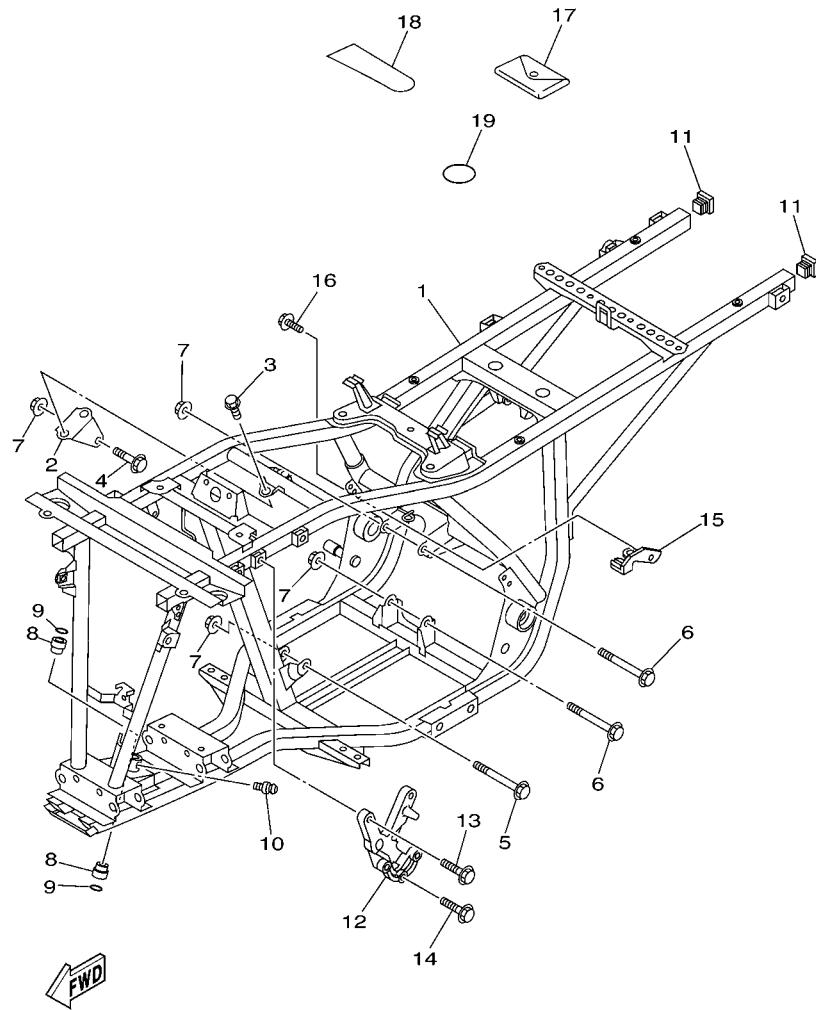




  
 1P01100-D190

**FIG. 19 SHIFT SHAFT**

REF. NO.	PART NO.	DESCRIPTION	USA	CAN	EUR	OCE	REMARKS
1	93102-12803	OIL SEAL	1	1	1	1	
2	93608-30839	PIN, DOWEL	1	1	1	1	
3	5XG-E8177-00	BOLT, STOPPER	1	1	1	1	
4	5XG-E8103-00	SHIFT SHAFT COMP.	1	1	1	1	
5	5XG-E8120-00	SHIFT LEVER ASSY	1	1	1	1	
6	90506-08227	.SPRING, TENSION	1	1	1	1	
7	90508-29570	.SPRING, TORSION	1	1	1	1	
8	90201-12588	WASHER, PLATE	2	2	2	2	
9	5XG-E8140-00	STOPPER LEVER ASSY	1	1	1	1	
10	90508-26539	SPRING, TORSION	1	1	1	1	
11	24W-18179-00	GUIDE	1	1	1	1	
12	21V-18181-00	HOLDER, PAWL	1	1	1	1	
13	24W-18104-00	SHIFT GUIDE COMP.	1	1	1	1	
14	5XG-E817A-00	ARM, SHIFT 3	1	1	1	1	
15	5XG-E8126-00	PIN, LEVER	1	1	1	1	
16	5XG-E8118-00	PIN, JOINT	1	1	1	1	
17	92907-08600	WASHER, PLATE	1	1	1	1	
18	91401-16012	PIN, COTTER	1	1	1	1	
19	5XG-E8127-00	STOPPER, SCREW	1	1	1	1	
20	93210-07590	O-RING	1	1	1	1	
21	90201-08093	WASHER, PLATE	1	1	1	1	
22	95307-08700	NUT	1	1	1	1	
23	90501-16768	SPRING, COMPRESSION	1	1	1	1	
24	1P0-18110-00	SHIFT PEDAL ASSY	1	1	1	1	
25	22N-18113-00	.COVER, SHIFT PEDAL	1	1	1	1	
26	97017-06020	BOLT	1	1	1	1	

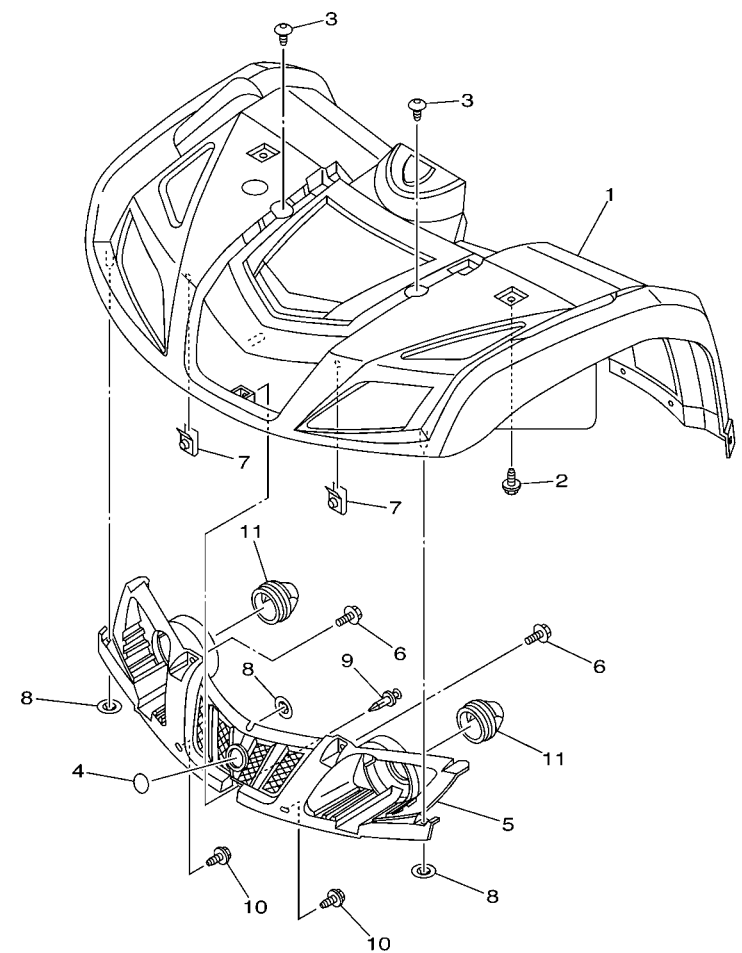


1P03300-D200

FIG. 20 FRAME

REF. NO.	PART NO.	DESCRIPTION	USA	CAN	EUR	OCE	REMARKS
1	1P0-F1110-01	FRAME COMP.	1	1	1	1	
2	4XE-F1315-00	STAY, ENGINE 2	1	1	1	1	
3	9581P-08012	BOLT, FLANGE	2	2	2	2	
4	90105-08805	BOLT, FLANGE	1	1	1	1	
5	90105-08888	BOLT, FLANGE	1	1	1	1	
6	90105-08806	BOLT, FLANGE	2	2	2	2	
7	90179-08893	NUT	4	4	4	4	
8	90381-15040	BUSH, SOLID	2	2	2	2	
9	93210-15414	O-RING	2	2	2	2	
10	93700-06004	NIPPLE, GREASE	1	1	1	1	
11	5FU-F111A-00	CAP, MAIN PIPE	2	2	2	2	
12	1P0-F1585-00	ARM	1	1	1	1	
13	95827-08020	BOLT, FLANGE	2	2	2	2	
14	95827-08020	BOLT, FLANGE	3	3	3	3	
15	1P0-F1453-00	BRACKET, SWITCH	1	1	1	1	
16	9582P-06012	BOLT, FLANGE	1	1	1	1	
17	5ND-F8100-00	TOOL KIT	1	1	1	1	
18	1NV-2811A-01	GAUGE, AIR	1	1	1	1	
19	93210-64297	O-RING	1	1	1	1	

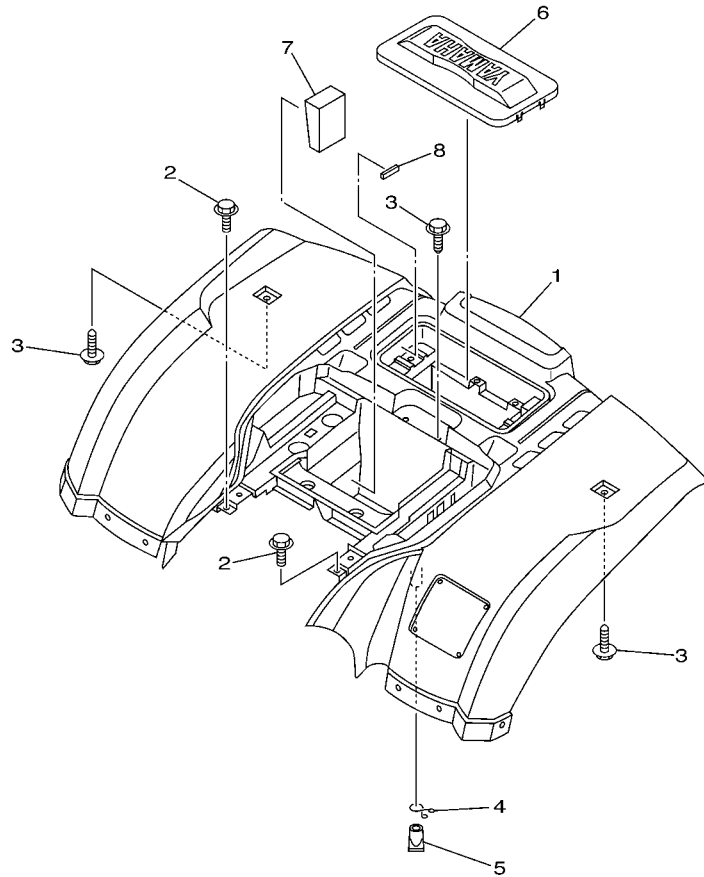
**FIG. 21 FRONT FENDER**



**FWD**  
1P01100-D210

REF. NO.	PART NO.	DESCRIPTION	USA	CAN	EUR	OCE	REMARKS
1	1P0-F1500-00	FRONT FENDER ASSY	1				UR FOR RTR
	1P0-F1500-10	FRONT FENDER ASSY	1				UR FOR PDG
	1P0-F1500-20	FRONT FENDER ASSY	1	1			UR FOR DPBSN
	1P0-F1500-30	FRONT FENDER ASSY			1		UR FOR RTR
	1P0-F1500-40	FRONT FENDER ASSY			1		UR FOR PDG
	1P0-F1500-50	FRONT FENDER ASSY			1		UR FOR DPBSE
	1P0-F1500-60	FRONT FENDER ASSY				1	FOR DPBSE
2	90119-06060	BOLT, WITH WASHER	2	2	2	2	
3	90149-05299	SCREW	2	2	2	2	
4	5FU-F175B-01	TUNING FORK MARK	1	1	1	1	
5	5UH-F8309-01	GRILLE, FRONT	1	1	1	1	
6	90119-06060	BOLT, WITH WASHER	2	2	2	2	
7	90183-06053	NUT, SPRING	2	2	2	2	
8	90183-08800	NUT, SPRING	3	3	3	3	
9	90269-06804	RIVET	1	1	1	1	
10	90119-06060	BOLT, WITH WASHER	2	2	2	2	
11	5UH-F8349-00	CAP	2	2	2	2	

**FIG. 22 REAR FENDER**

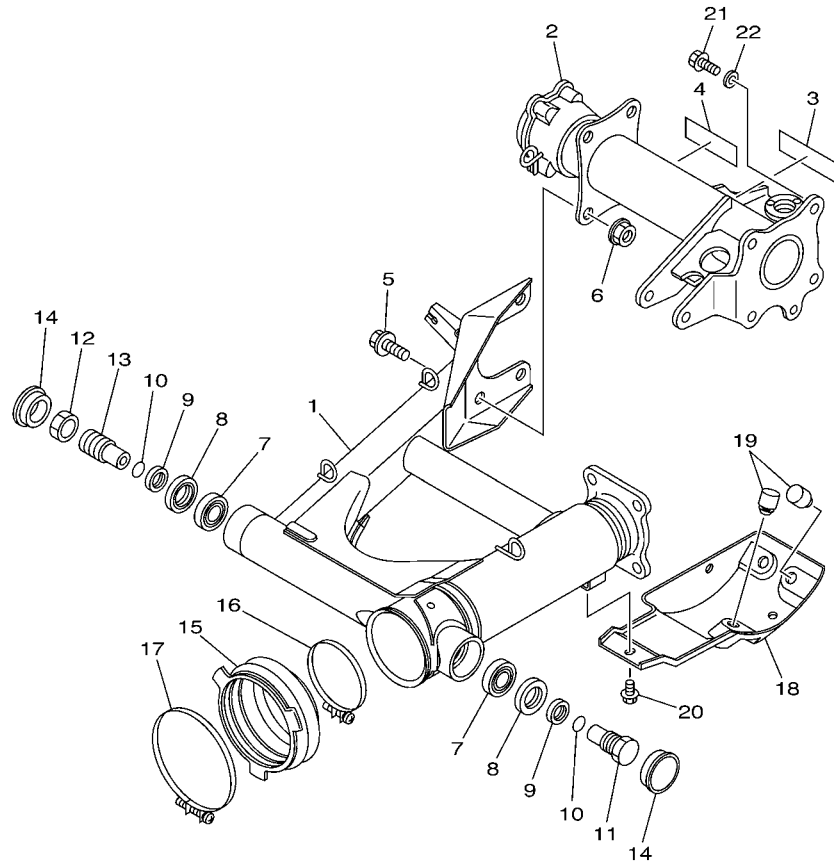


**FWD**  
1P01100-D220

REF. NO.	PART NO.	DESCRIPTION	USA	CAN	EUR	OCE	REMARKS
1	1P0-F1600-00	REAR FENDER ASSY.	1				UR FOR RTR
	1P0-F1600-10	REAR FENDER ASSY.	1				UR FOR PDG
	1P0-F1600-20	REAR FENDER ASSY.	1	1			UR FOR DPBSN
	1P0-F1600-30	REAR FENDER ASSY.			1		UR FOR RTR
	1P0-F1600-40	REAR FENDER ASSY.			1		UR FOR PDG
	1P0-F1600-50	REAR FENDER ASSY.			1		UR FOR DPBSE
	1P0-F1600-60	REAR FENDER ASSY.				1	UR FOR DPBSE
2	90119-06227	BOLT, WITH WASHER	2	2	2	2	
3	90119-06060	BOLT, WITH WASHER	3	3	3	3	
4	90467-16195	CLIP	1	1	1	1	
5	5BF-1443E-00	PIPE, DRAIN	1	1	1	1	
6	1P0-F1651-00	COVER, REAR FENDER	1		1		UR FOR RTR
	1P0-F1651-10	COVER, REAR FENDER	1		1		UR FOR PDG
	1P0-F1651-50	COVER, REAR FENDER	1	1			UR FOR DPBSN
	1P0-F1651-30	COVER, REAR FENDER			1	1	UR FOR DPBSE
7	1P0-F1649-00	DAMPER	1	1	1	1	
8	1P0-F4285-00	CLAMP, DAMPER	2	2	2	2	



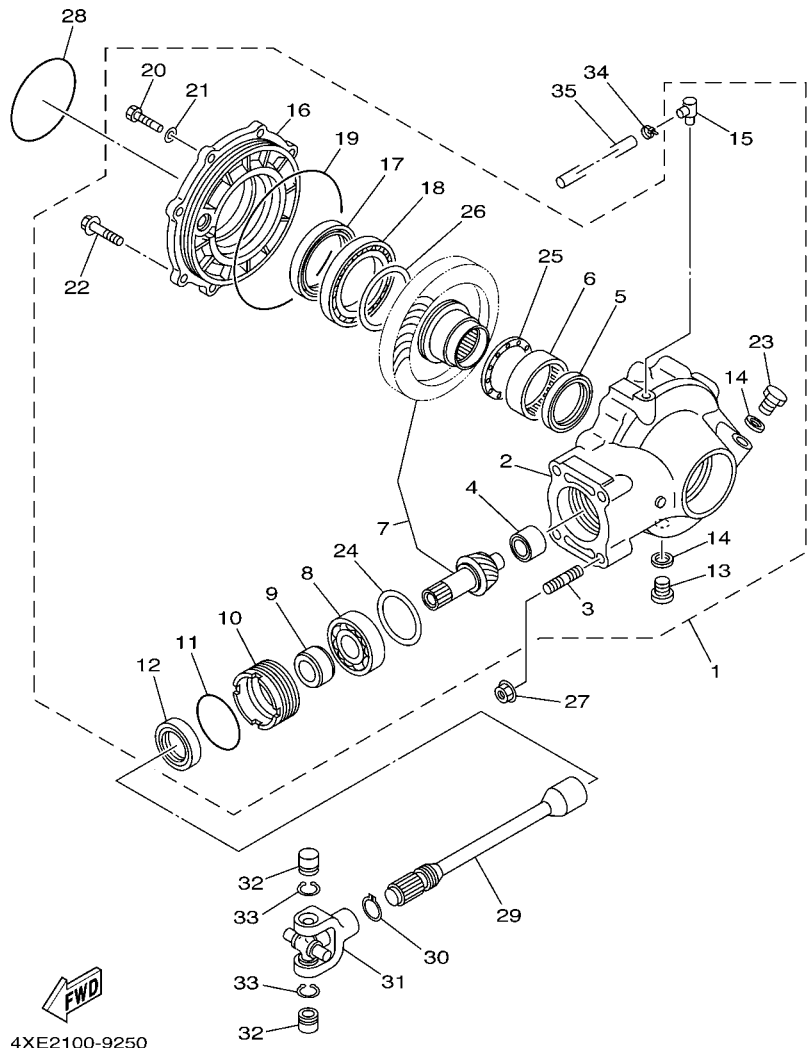
FIG. 24 REAR ARM



REF. NO.	PART NO.	DESCRIPTION	USA	CAN	EUR	OOE	REMARKS
1	4XE-F2110-20	REAR ARM COMP.	1	1	1	1	
2	1P0-G6540-00	REAR AXLE HOUSING COMP.	1	1	1	1	
3	4XE-F151K-00	LABEL 7	1	1	1	1	ENGLISH
4	4XE-F151K-10	LABEL 7		1			FRENCH
5	9581P-12025	BOLT, FLANGE	4	4	4	4	
6	95707-12500	NUT, FLANGE	4	4	4	4	
7	93332-000Y3	BEARING	2	2	2	2	
8	93102-25017	OIL SEAL	2	2	2	2	
9	90387-1711G	COLLAR	2	2	2	2	
10	93210-17718	O-RING	2	2	2	2	
11	4XE-F2141-00	SHAFT, PIVOT	1	1	1	1	
12	4XE-F2143-00	NUT	1	1	1	1	
13	4XE-F214H-00	SHAFT, PIVOT 2	1	1	1	1	
14	90338-34264	PLUG	2	2	2	2	
15	29U-22189-00	BOOT, RUBBER	1	1	1	1	
16	90460-85135	CLAMP, HOSE	1	1	1	1	
17	90460-99228	CLAMP, HOSE	1	1	1	1	
18	4XE-F219X-00	COVER	1	1	1	1	
19	109-27114-00	STOPPER, MAIN STAND	3	3	3	3	
20	95807-08012	BOLT, FLANGE	2	2	2	2	
21	90105-10893	BOLT, FLANGE	4	4	4	4	
22	90201-101J1	WASHER, PLATE	4	4	4	4	



4XEE100-2240



4XE2100-9250

FIG. 25 DRIVE SHAFT

REF. NO.	PART NO.	DESCRIPTION	USA	CAN	EUR	OCE	REMARKS
1	4XE-G6101-01	REAR AXLE GEAR CASE ASSY	1	1	1	1	
2	4XE-G6151-01	.HOUSING, DRIVE SHAFT	1	1	1	1	
3	90116-10840	.BOLT, STUD	4	4	4	4	
4	4XE-G6102-00	.BEARING ASSY	1	1	1	1	
5	93101-52116	.OIL SEAL	1	1	1	1	
6	93317-855Y9	.BEARING	1	1	1	1	
7	4XE-Y4612-00	.RING GEAR SET	1	1	1	1	
8	93306-305Y6	.BEARING	1	1	1	1	
9	90387-255H9	.COLLAR	1	1	1	1	
10	29U-46125-00	.RETAINER, BEARING	1	1	1	1	
11	93210-59531	.O-RING	1	1	1	1	
12	93101-38098	.OIL SEAL	1	1	1	1	
13	90340-14046	.PLUG, STRAIGHT SCREW	1	1	1	1	
14	214-11198-01	.GASKET	2	2	2	2	
15	2N4-15371-00	.BREATHER	1	1	1	1	
16	4XE-G6152-01	.HOUSING, BEARING	1	1	1	1	
17	93102-65386	.OIL SEAL	1	1	1	1	
18	93316-013Y0	.BEARING	1	1	1	1	
19	93211-51749	.O-RING	1	1	1	1	
20	9702P-08025	.BOLT	6	6	6	6	
21	9290P-08600	.WASHER	6	6	6	6	
22	9581P-10045	.BOLT, FLANGE	2	2	2	2	
23	90340-14029	.PLUG, STRAIGHT SCREW	1	1	1	1	
24	4XE-E7537-15	.SHIM, THRUST(T=0.15MM)	1	1	1	1	UR
	4XE-E7537-30	.SHIM, THRUST(T=0.30MM)	1	1	1	1	UR
	4XE-E7537-40	.SHIM, THRUST(T=0.40MM)	1	1	1	1	UR
	4XE-E7537-45	.SHIM, THRUST(T=0.45MM)	1	1	1	1	UR

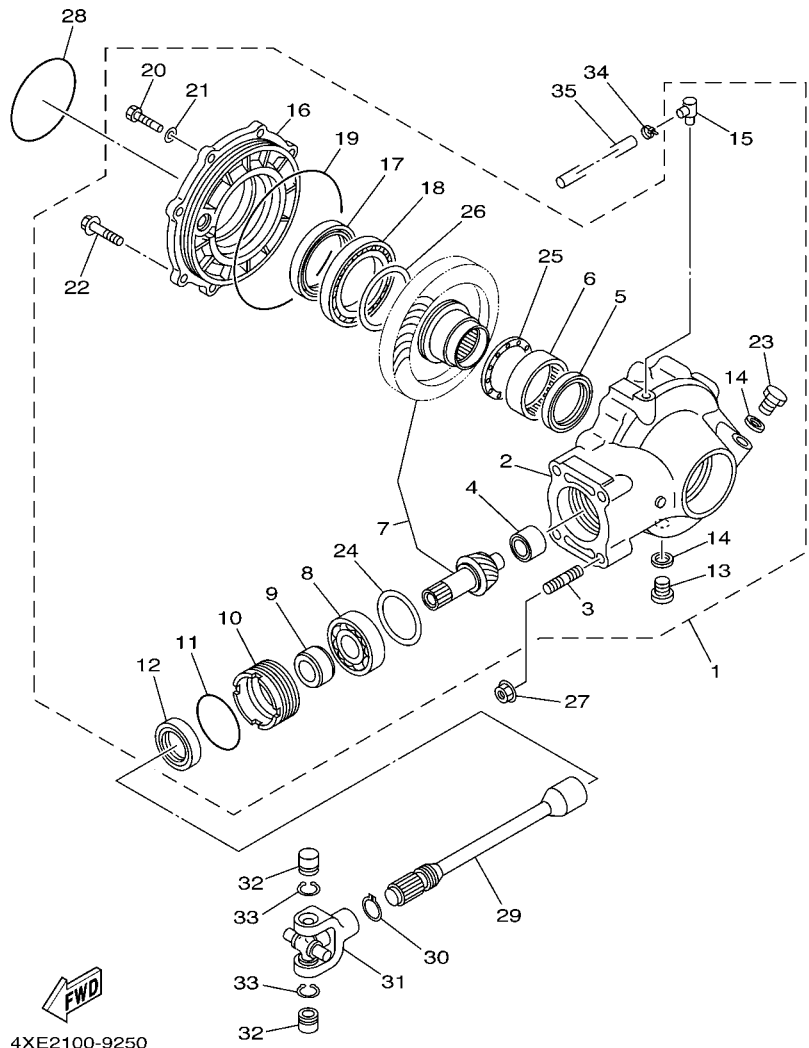


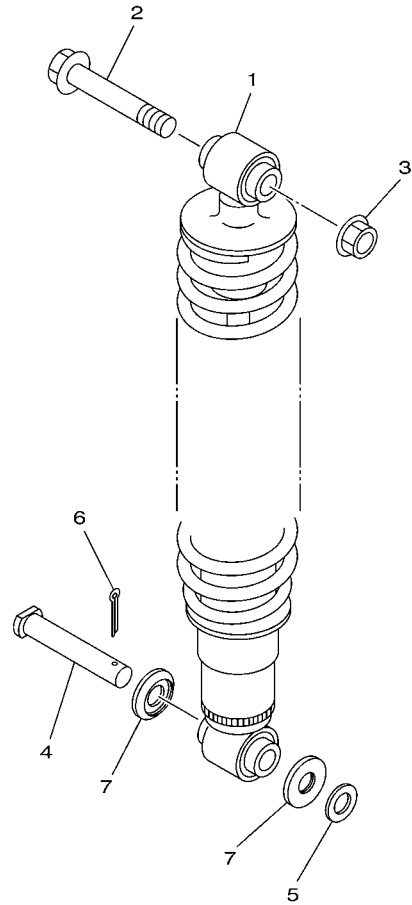
FIG. 25 DRIVE SHAFT

REF. NO.	PART NO.	DESCRIPTION	USA	CAN	EUR	OCE	REMARKS
24	4XE-E7537-50	.SHIM, THRUST(T=0.50MM)	1	1	1	1	UR
	4XE-E7537-60	.SHIM, THRUST(T=0.60MM)	1	1	1	1	UR
25	4XE-G6118-10	.SHIM, THRUST(T=1.0MM)	1	1	1	1	UR
	4XE-G6118-11	.SHIM, THRUST(T=1.1MM)	1	1	1	1	UR
	4XE-G6118-12	.SHIM, THRUST(T=1.2MM)	1	1	1	1	UR
	4XE-G6118-13	.SHIM, THRUST(T=1.3MM)	1	1	1	1	UR
	4XE-G6118-14	.SHIM, THRUST(T=1.4MM)	1	1	1	1	UR
	4XE-G6118-15	.SHIM, THRUST(T=1.5MM)	1	1	1	1	UR
	4XE-G6118-16	.SHIM, THRUST(T=1.6MM)	1	1	1	1	UR
	4XE-G6118-17	.SHIM, THRUST(T=1.7MM)	1	1	1	1	UR
	4XE-G6118-18	.SHIM, THRUST(T=1.8MM)	1	1	1	1	UR
	4XE-G6118-19	.SHIM, THRUST(T=1.9MM)	1	1	1	1	UR
	4XE-G6118-20	.SHIM, THRUST(T=2.0MM)	1	1	1	1	UR
	4XE-G6118-21	.SHIM, THRUST(T=2.1MM)	1	1	1	1	UR
	4XE-G6118-A3	.SHIM, THRUST(T=1.35MM)	1	1	1	1	UR
	4XE-G6118-A4	.SHIM, THRUST(T=1.45MM)	1	1	1	1	UR
	4XE-G6118-A5	.SHIM, THRUST(T=1.55MM)	1	1	1	1	UR
26	4XE-G6117-25	.SHIM, RING GEAR(T=0.25MM)	1	1	1	1	UR
	4XE-G6117-30	.SHIM, RING GEAR(T=0.30MM)	1	1	1	1	UR
	4XE-G6117-35	.SHIM, RING GEAR(T=0.35MM)	1	1	1	1	UR
	4XE-G6117-40	.SHIM, RING GEAR(T=0.40MM)	1	1	1	1	UR
	4XE-G6117-45	.SHIM, RING GEAR(T=0.45MM)	1	1	1	1	UR
	4XE-G6117-50	.SHIM, RING GEAR(T=0.50MM)	1	1	1	1	UR
27	95707-10500	NUT, FLANGE	4	4	4	4	
28	93210-85706	O-RING	1	1	1	1	
29	4XE-G6172-00	SHAFT, DRIVE	1	1	1	1	
30	93410-22039	CIRCLIP	1	1	1	1	



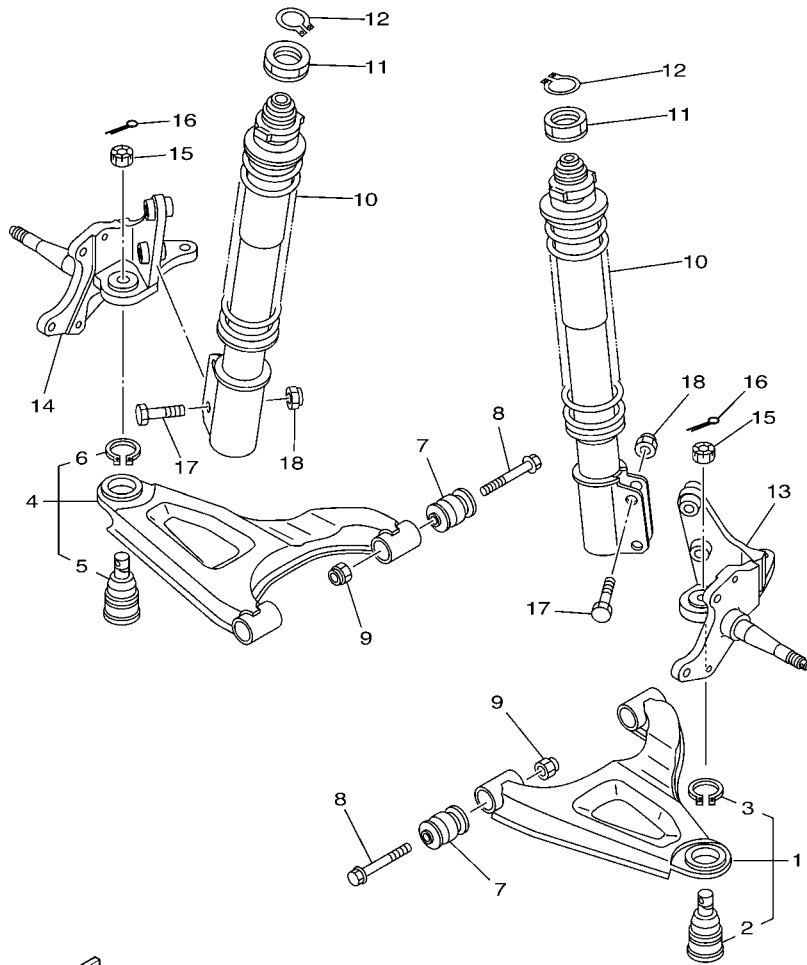


**FIG. 26 REAR SUSPENSION**



  
4XE2100-9260

REF. NO.	PART NO.	DESCRIPTION	USA	CAN	EUR	OCE	REMARKS
1	4XE-F2210-10	SHOCK ABSORBER ASSY, REAR	1	1	1	1	
2	90105-12889	BOLT, FLANGE	1	1	1	1	
3	90185-12072	NUT, SELF-LOCKING	1	1	1	1	
4	90240-12092	PIN, CLEVIS	1	1	1	1	
5	90201-127J6	WASHER, PLATE	1	1	1	1	
6	91401-30025	PIN, SPLIT	1	1	1	1	
7	1W1-22128-00	COVER, THRUST 1	2	2	2	2	

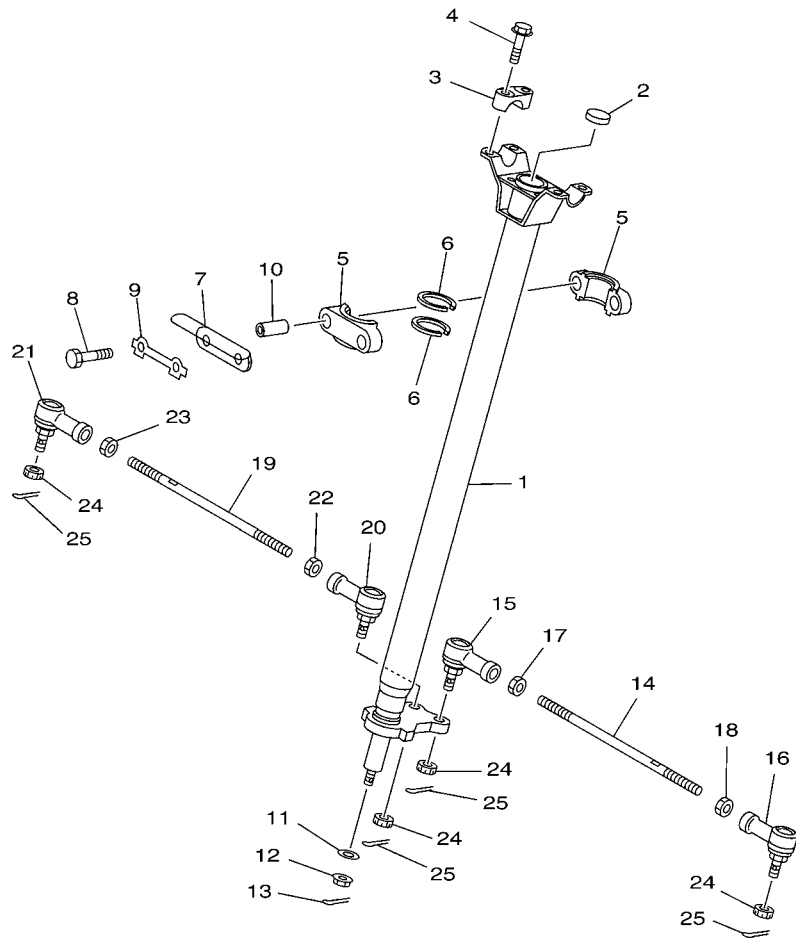


4XE-H100-B270

FIG. 27 FRONT SUSPENSION & WHEEL

REF. NO.	PART NO.	DESCRIPTION	USA	CAN	EUR	OCE	REMARKS
1	4XE-F3570-10	FRONT LOWER ARM COMP. (LEFT)	1	1	1	1	
2	4XE-F3549-00	.BALL JOINT 1	1	1	1	1	
3	93410-32826	.CIRCLIP	1	1	1	1	
4	4XE-F3580-10	FRONT LOWER ARM COMP. (RIGHT)	1	1	1	1	
5	4XE-F3549-00	.BALL JOINT 1	1	1	1	1	
6	93410-32826	.CIRCLIP	1	1	1	1	
7	2HR-23526-00	BUSH	4	4	4	4	
8	90105-10890	BOLT, FLANGE	4	4	4	4	
9	90185-10844	NUT, SELF-LOCKING	4	4	4	4	
10	4XE-F3350-10	SHOCK ABSORBER ASSY	2	2	2	2	
11	90179-35625	NUT	2	2	2	2	
12	93410-32826	CIRCLIP	2	2	2	2	
13	4XE-F3501-20	STEERING KNUCKLE ASSY (LEFT)	1	1	1	1	
14	4XE-F3502-20	STEERING KNUCKLE ASSY (RIGHT)	1	1	1	1	
15	90171-12816	NUT, CASTLE	2	2	2	2	
16	91401-25020	PIN, COTTER	2	2	2	2	
17	90101-12882	BOLT	4	4	4	4	
18	9561P-12100	NUT	4	4	4	4	

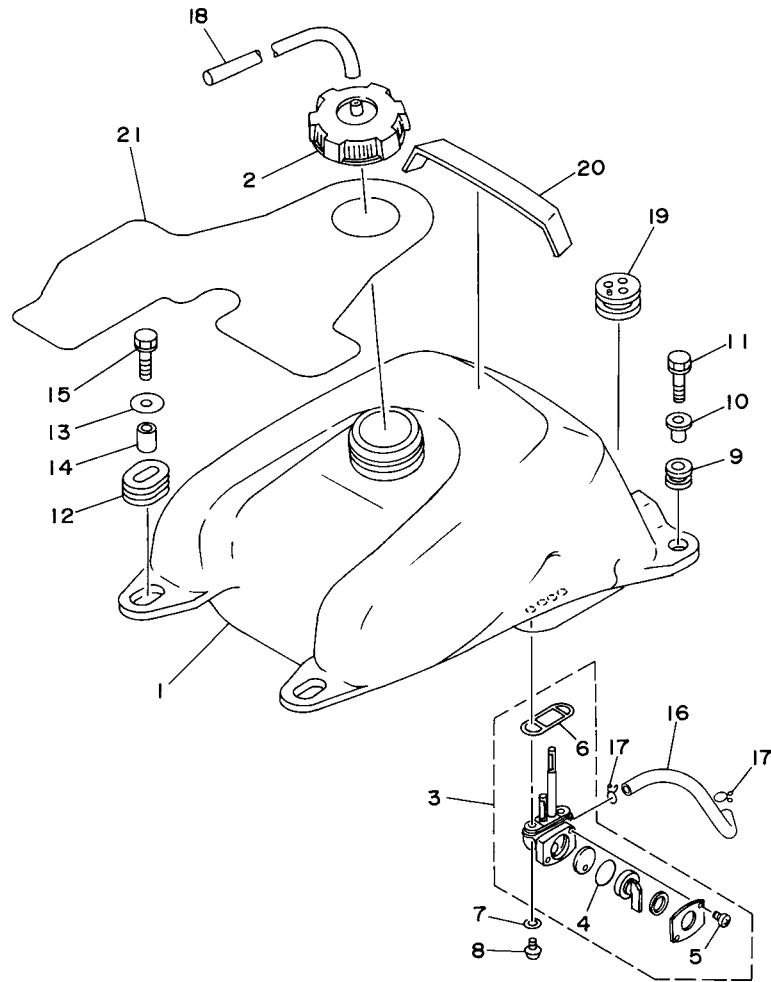
FIG. 28 STEERING



1P01100-D280

REF. NO.	PART NO.	DESCRIPTION	USA	CAN	EUR	OCE	REMARKS
1	1P0-F3813-00	COLUMN, STEERING 2	1	1	1	1	
2	90336-28053	PLUG, TAPER	1	1	1	1	
3	8K1-23814-00	HOLDER, HANDLE	2	2	2	2	
4	9581P-08030	BOLT, FLANGE	4	4	4	4	
5	1UY-23812-00	PLANE BEARING, STEERING	2	2	2	2	
6	93112-31011	OIL SEAL	2	2	2	2	
7	4XE-F3868-10	BRACKET, STEERING LOWER	1	1	1	1	
8	9702P-08060	BOLT	2	2	2	2	
9	4XE-F3894-00	WASHER, LOCK 1	1	1	1	1	
10	90387-090R0	COLLAR	2	2	2	2	
11	90201-108P8	WASHER, PLATE	1	1	1	1	
12	90185-10115	NUT, SELF-LOCKING	1	1	1	1	
13	91401-20025	PIN, COTTER	1	1	1	1	
14	4XE-F3831-00	ROD, TIE	1	1	1	1	
15	1D9-F3841-01	JOINT, UNIVERSAL 1	1	1	1	1	
16	5ND-F3845-01	JOINT, UNIVERSAL 2	1	1	1	1	
17	4XE-F3833-00	NUT 1	1	1	1	1	
18	4XE-F3834-00	NUT 2	1	1	1	1	
19	4XE-F3831-00	ROD, TIE	1	1	1	1	
20	1D9-F3841-01	JOINT, UNIVERSAL 1	1	1	1	1	
21	5ND-F3845-01	JOINT, UNIVERSAL 2	1	1	1	1	
22	4XE-F3833-00	NUT 1	1	1	1	1	
23	4XE-F3834-00	NUT 2	1	1	1	1	
24	90171-12816	NUT, CASTLE	4	4	4	4	
25	91401-25020	PIN, COTTER	4	4	4	4	

FIG. 29 FUEL TANK

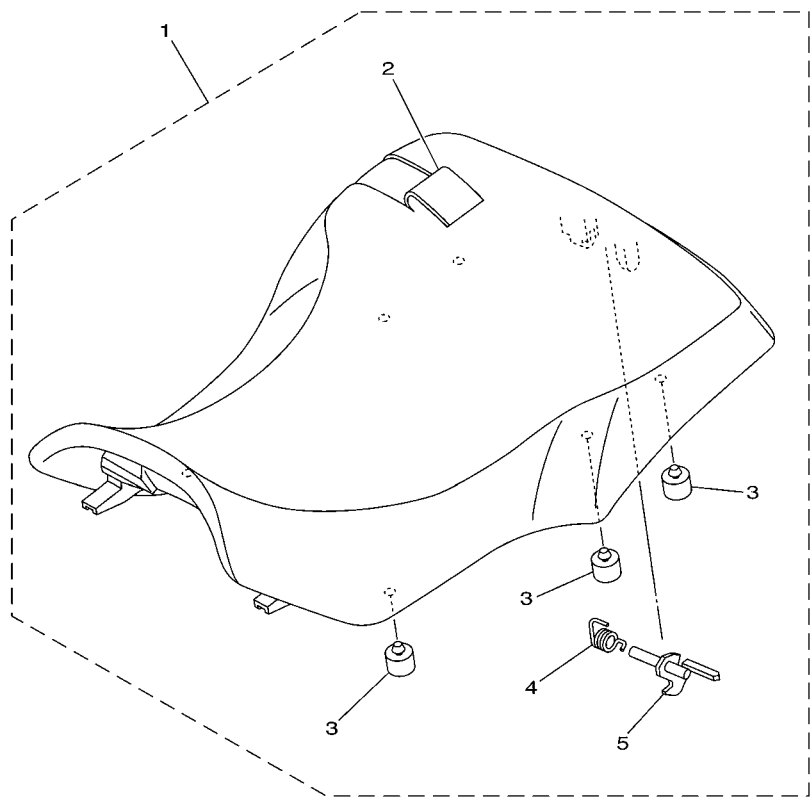


REF. NO.	PART NO.	DESCRIPTION	USA	CAN	EUR	OCE	REMARKS
1	4XE-F4110-00	FUEL TANK COMP.	1	1	1	1	
2	5KM-24610-00	CAP ASSY	1	1	1	1	
3	3JN-24500-02	FUEL COCK ASSY 1	1	1	1	1	
4	3AJ-24534-01	.SEAL, COCK	1	1	1	1	
5	98507-03008	.SCREW, PAN HEAD	2	2	2	2	
6	4X8-24512-00	.O-RING	1	1	1	1	
7	90202-05193	WASHER, PLATE	2	2	2	2	
8	90149-06011	SCREW	2	2	2	2	
9	90480-18290	GROMMET	2	2	2	2	
10	90387-066J1	COLLAR	2	2	2	2	
11	90119-06831	BOLT, WITH WASHER	2	2	2	2	
12	90480-01400	GROMMET	2	2	2	2	
13	90201-060L5	WASHER, PLATE	2	2	2	2	
14	90387-07598	COLLAR	2	2	2	2	
15	90119-06831	BOLT, WITH WASHER	2	2	2	2	
16	1P0-24311-00	PIPE, FUEL 1	1	1	1	1	
17	90467-10008	CLIP	2	2	2	2	
18	90445-08809	HOSE (L500)	1	1	1	1	
19	4BD-24339-00	GROMMET	1	1	1	1	
20	4XE-F4181-00	DAMPER, LOCATING 1	1	1	1	1	
21	4XE-F414H-00	DAMPER, PLATE 1	1	1	1	1	



1P01100-D290

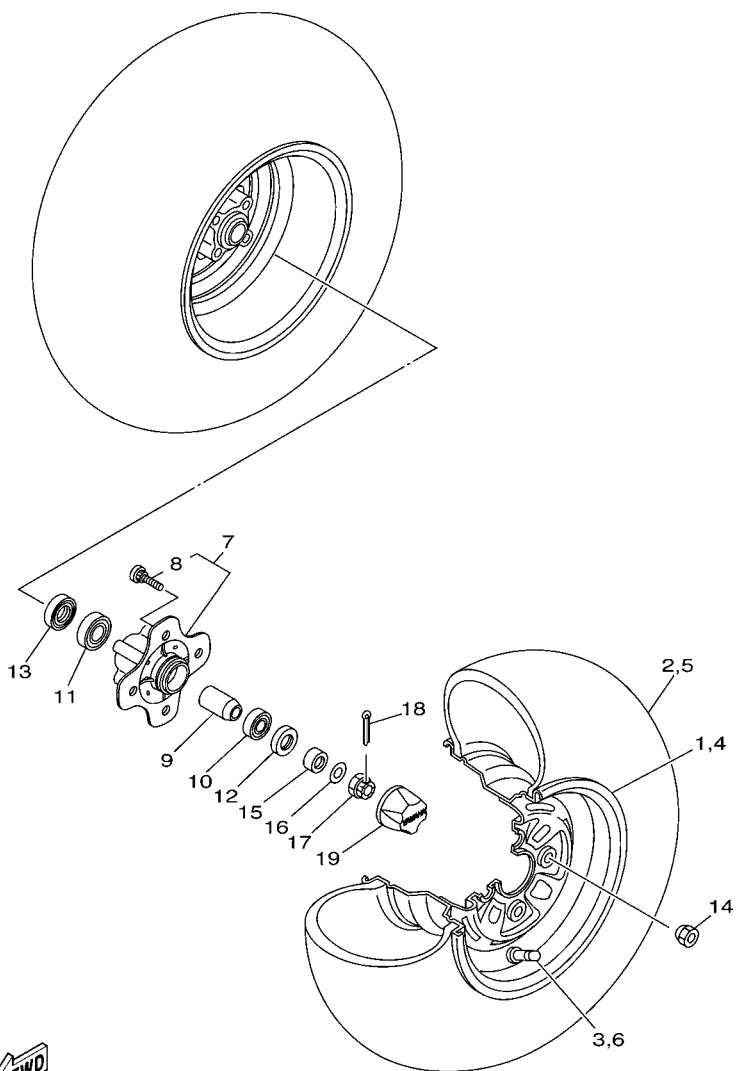
FIG. 30 SEAT



REF. NO.	PART NO.	DESCRIPTION	USA	CAN	EUR	OCE	REMARKS
1	5ND-F4710-03	SINGLE SEAT ASSY	1	1		1	
	5ND-F4710-22	SINGLE SEAT ASSY			1		
2	5ND-F470F-01	.SEAT COVER COMP.	1	1		1	
	5ND-F470F-21	.SEAT COVER COMP.			1		
3	4XE-F4747-00	.DAMPER, SEAT	6	6	6	6	
4	4XE-F478V-00	.SPRING, TORSION	1	1	1	1	
5	5ND-F4776-00	.LEVER, SEAT	1	1	1	1	

  
5ND1100-3320

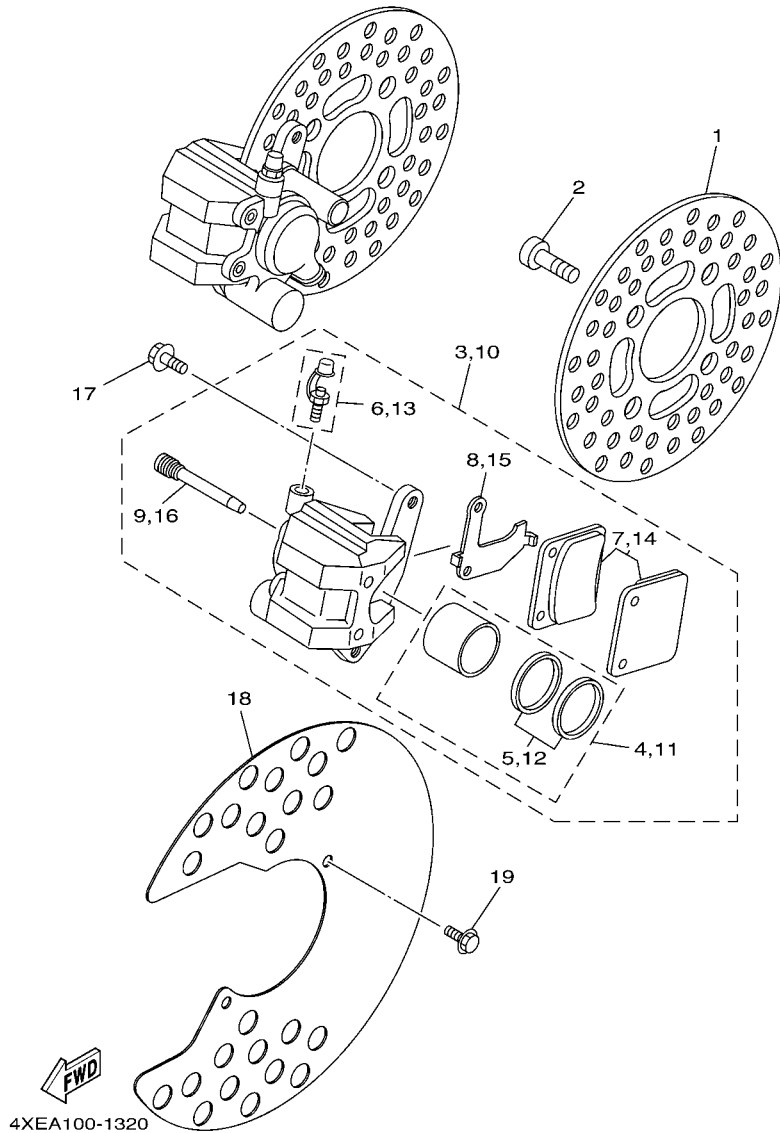
**FIG. 31 FRONT WHEEL**



4XEE100-2310

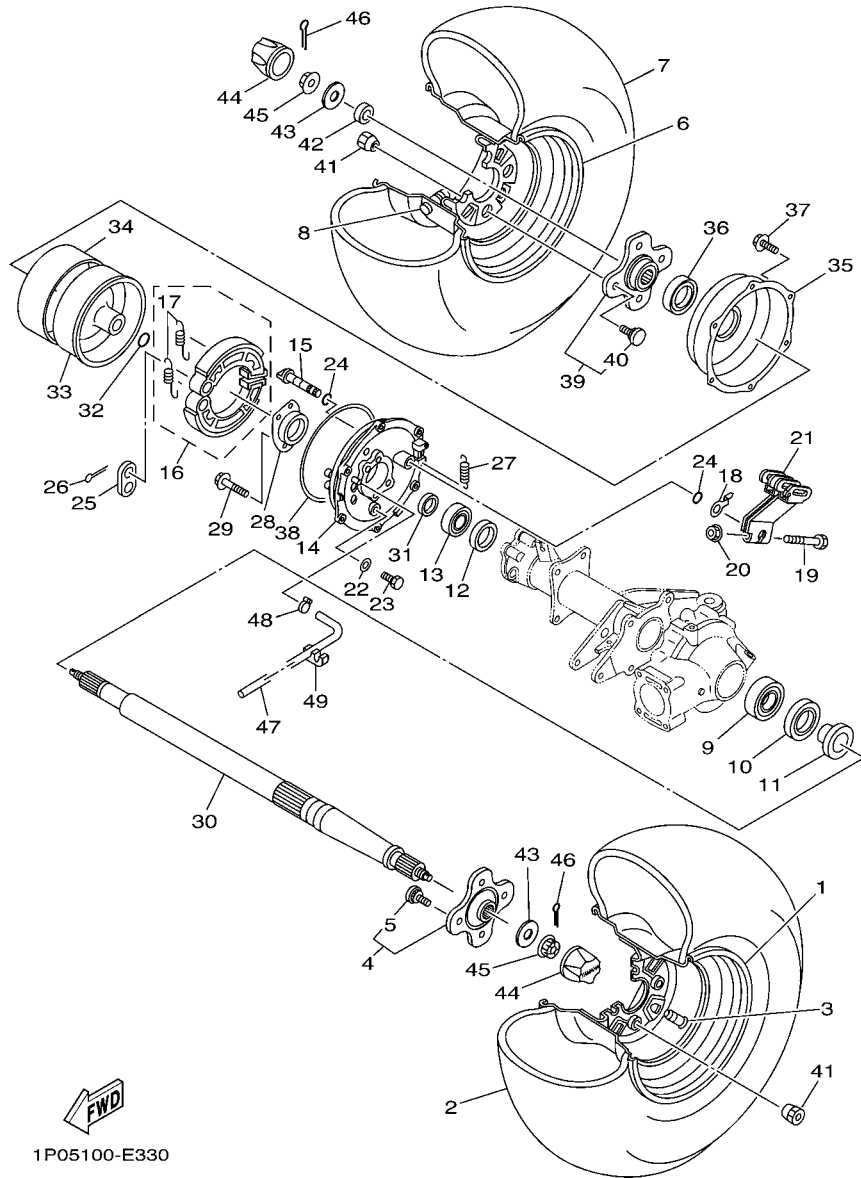
REF. NO.	PART NO.	DESCRIPTION	USA	CAN	EUR	OCE	REMARKS
1	4XE-F5180-50	WHEEL COMP.	1	1	1	1	
2	94107-10800	TIRE (AT 22X 7-10, M-905)	1	1	1	1	CHENG SHIN
3	93900-00813	VALVE, RIM (TR413)	1	1	1	1	
4	4XE-F5180-50	WHEEL COMP.	1	1	1	1	
5	94107-10800	TIRE (AT 22X 7-10, M-905)	1	1	1	1	CHENG SHIN
6	93900-00813	VALVE, RIM (TR413)	1	1	1	1	
7	4XE-F5111-20	HUB, FRONT	2	2	2	2	
8	90114-10804	.BOLT, SERRATION	4	4	4	4	
9	1UY-25117-00	SPACER, BEARING	2	2	2	2	
10	93306-004YX	BEARING	2	2	2	2	
11	93306-202XM	BEARING	2	2	2	2	
12	93102-22216	OIL SEAL	2	2	2	2	
13	93105-26026	OIL SEAL	2	2	2	2	
14	90179-10540	NUT	8	8	8	8	
15	90387-150R1	COLLAR	2	2	2	2	
16	90201-148R0	WASHER, PLATE	2	2	2	2	
17	90171-14817	NUT, CASTLE	2	2	2	2	
18	91401-30025	PIN, SPLIT	2	2	2	2	
19	52H-2512A-00	CAP, WHEEL	2	2	2	2	

**FIG. 32 FRONT BRAKE CALIPER**



REF. NO.	PART NO.	DESCRIPTION	USA	CAN	EUR	OCE	REMARKS
1	4XE-F582T-10	DISC, BRAKE (LEFT)	2	2	2	2	
2	90149-08268	SCREW	8	8	8	8	
3	3GD-2580T-00	CALIPER ASSY (LEFT)	1	1	1	1	
4	3GD-W0057-00	.PISTON ASSY, CALIPER	1	1	1	1	
5	3GD-W0047-00	..CALIPER SEAL KIT	1	1	1	1	
6	1UY-W0048-50	.BLEED SCREW KIT	1	1	1	1	
7	3GD-W0045-00	.BRAKE PAD KIT	1	1	1	1	
8	3GD-25827-00	.SHIM, CALIPER	1	1	1	1	
9	3GD-25933-00	.PIN, PAD	2	2	2	2	
10	3GD-2580U-00	CALIPER ASSY (RIGHT)	1	1	1	1	
11	3GD-W0057-00	.PISTON ASSY, CALIPER	1	1	1	1	
12	3GD-W0047-00	..CALIPER SEAL KIT	1	1	1	1	
13	1UY-W0048-50	.BLEED SCREW KIT	1	1	1	1	
14	3GD-W0045-00	.BRAKE PAD KIT	1	1	1	1	
15	3GD-25828-00	.SHIM, CALIPER	1	1	1	1	
16	3GD-25933-00	.PIN, PAD	2	2	2	2	
17	90105-088B2	BOLT, FLANGE	4	4	4	4	
18	4XE-F514A-00	RING, WHEEL 1 (LEFT)	2	2	2	2	
19	9582P-06012	BOLT, FLANGE	4	4	4	4	

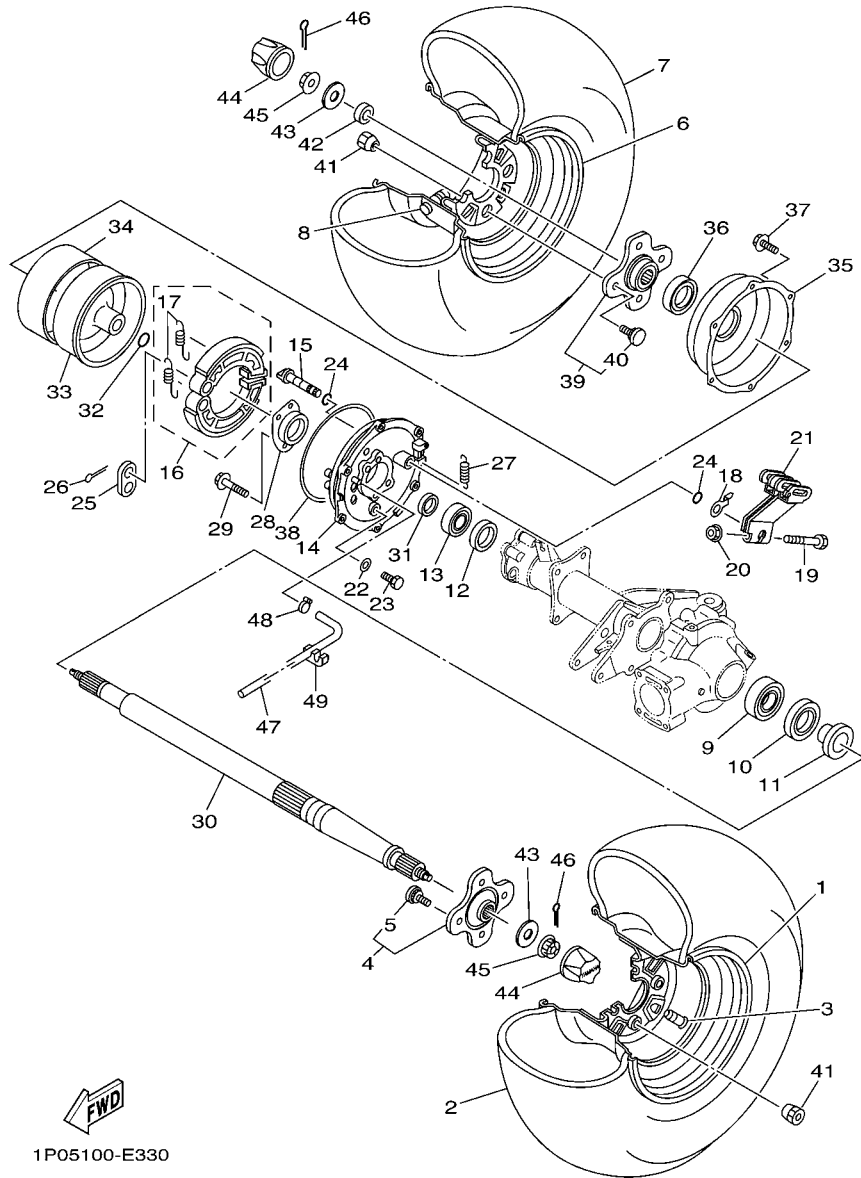




1P05100-E330

FIG. 33 REAR WHEEL

REF. NO.	PART NO.	DESCRIPTION	USA	CAN	EUR	OCE	REMARKS
1	4XE-F5390-50	REAR WHEEL COMP.	1	1	1	1	
2	94110-10800	TIRE (AT 22X10-10, M-906)	1	1	1	1	CHENG SHIN
3	93900-00810	VALVE, RIM (TR413)	1	1	1	1	DUNLOP
4	5ND-F5383-10	COLLAR, WHEEL	1	1	1	1	
5	90114-10804	.BOLT, SERRATION	4	4	4	4	
6	4XE-F5390-50	REAR WHEEL COMP.	1	1	1	1	
7	94110-10800	TIRE (AT 22X10-10, M-906)	1	1	1	1	CHENG SHIN
8	93900-00810	VALVE, RIM (TR413)	1	1	1	1	DUNLOP
9	93306-008Y0	BEARING	1	1	1	1	
10	93106-47040	OIL SEAL	1	1	1	1	
11	4SH-25367-01	COVER, HUB DUST	1	1	1	1	
12	93101-35097	OIL SEAL	1	1	1	1	
13	93306-278Y0	BEARING	1	1	1	1	
14	5VH-F5321-10	PLATE, BRAKE SHOE	1	1	1	1	
15	5VH-F5351-00	CAMSHAFT	1	1	1	1	
16	5VH-WF536-00	BRAKE SHOE SET	1	1	1	1	
17	5VH-F5333-00	.SPRING, RETURN	2	2	2	2	
18	5FU-F533A-10	PLATE, INDICATOR	1	1	1	1	
19	5VH-F5833-00	BOLT, FITTING	1	1	1	1	
20	9560L-06200	NUT, SELF-LOCKING	1	1	1	1	
21	1P0-F5355-00	LEVER, CAMSHAFT	1	1	1	1	
22	5VH-F5898-00	GASKET	1	1	1	1	
23	5VH-F5818-00	BOLT, CALIPER	1	1	1	1	
24	5VH-F5359-00	SEAL, CAMSHAFT	2	2	2	2	
25	5VH-F539F-00	PLATE 1	1	1	1	1	
26	91401-25020	PIN, COTTER	2	2	2	2	
27	90506-16482	SPRING, TENSION	1	1	1	1	

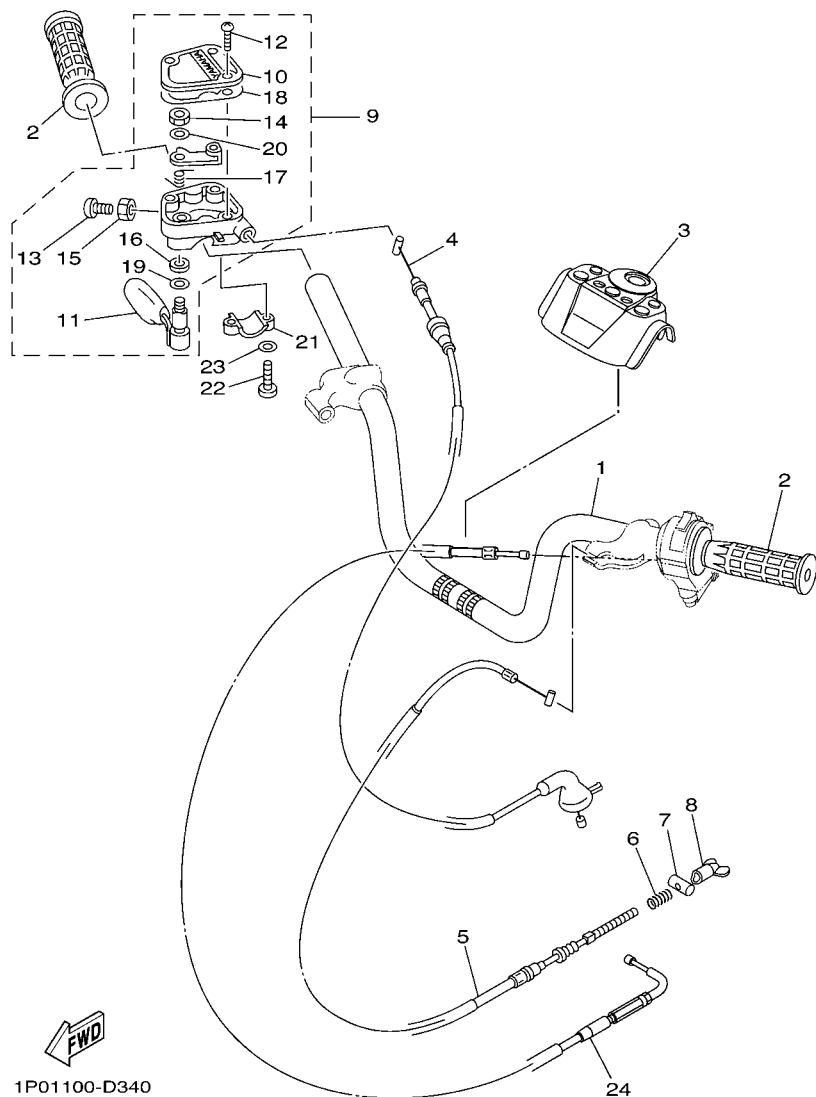


1P05100-E330

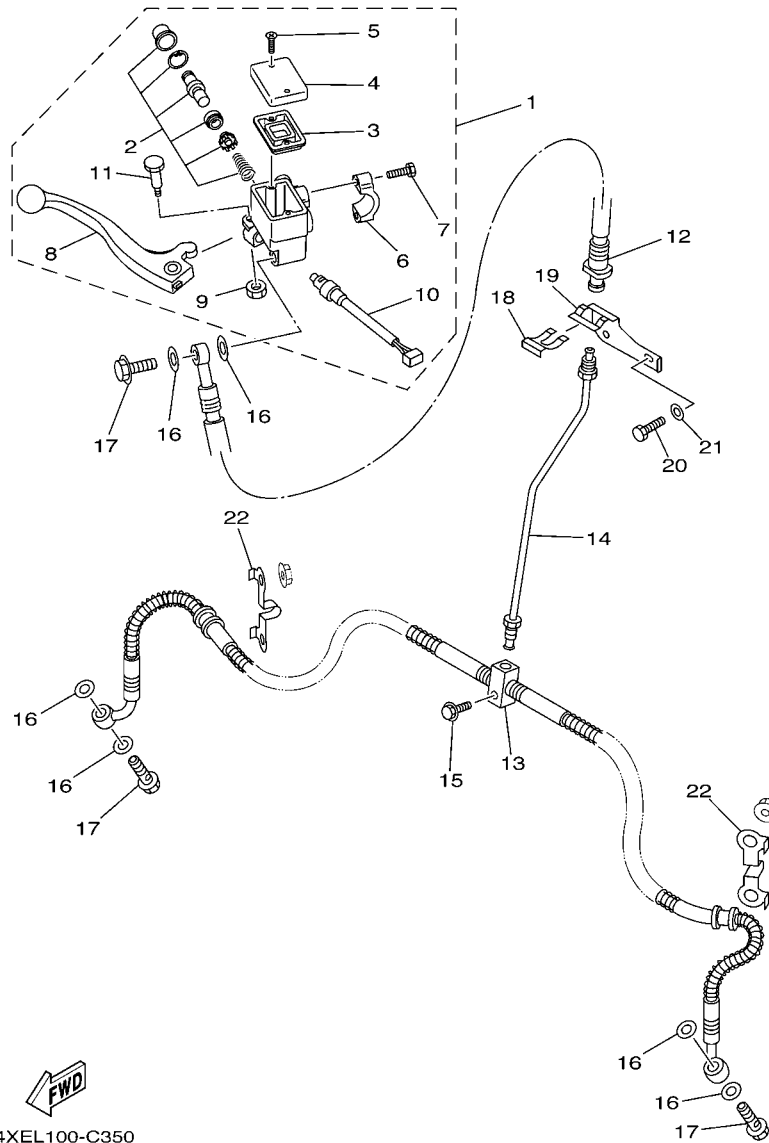
FIG. 33 REAR WHEEL

REF. NO.	PART NO.	DESCRIPTION	USA	CAN	EUR	OCE	REMARKS
28	4XE-G6513-00	RETAINER	1	1	1	1	
29	90105-08892	BOLT, FLANGE	4	4	4	4	
30	1P0-F5381-00	AXLE, WHEEL	1	1	1	1	
31	90387-284T0	COLLAR	1	1	1	1	
32	93210-26606	O-RING	1	1	1	1	
33	5FU-F531E-10	DRUM, BRAKE	1	1	1	1	
34	5FU-F5336-00	RING 2	1	1	1	1	
35	5FU-F5327-00	COVER, PLATE	1	1	1	1	
36	5FU-F5319-00	SEAL, HUB DUST	1	1	1	1	
37	9582P-06012	BOLT, FLANGE	6	6	6	6	
38	5FU-F537Y-00	SEAL, DUST	1	1	1	1	
39	5FU-F5377-10	COLLAR, WHEEL	1	1	1	1	
40	90114-10804	.BOLT, SERRATION	4	4	4	4	
41	90179-10540	NUT	8	8	8	8	
42	5FU-F5384-00	WASHER, WHEEL	1	1	1	1	
43	90201-168R1	WASHER, PLATE	2	2	2	2	
44	52H-2512A-00	CAP, WHEEL	2	2	2	2	
45	90171-16001	NUT, CASTLE	2	2	2	2	
46	91401-30030	PIN, COTTER	2	2	2	2	
47	90445-07810	HOSE (L1050)	1	1	1	1	
48	90467-07093	CLIP	1	1	1	1	
49	90468-15020	CLIP	2	2	2	2	

FIG. 34 STEERING HANDLE & CABLE



REF. NO.	PART NO.	DESCRIPTION	USA	CAN	EUR	OCE	REMARKS
1	5FU-F6111-10	HANDLEBAR	1	1	1	1	
2	5FU-F6241-10	GRIP	2	2	2	2	
3	1P0-F6124-00	PROTECTOR, HANDLEBAR	1	1	1	1	
4	1P0-26311-00	CABLE, THROTTLE 1	1	1	1	1	
5	1P0-26341-00	CABLE, BRAKE	1	1	1	1	
6	90501-10782	SPRING, COMPRESSION	1	1	1	1	
7	90249-12008	PIN	1	1	1	1	
8	20E-26343-00	NUT, ADJUSTING	1	1	1	1	
9	4KB-26250-10	THROTTLE LEVER ASSY	1	1	1	1	
10	4KB-2628F-10	.CAP, GEAR	1	1	1	1	
11	1NV-2625G-01	.LEVER, THROTTLE	1	1	1	1	
12	90149-04278	.SCREW	3	3	3	3	
13	98507-05020	.SCREW, PAN HEAD	1	1	1	1	
14	95607-05100	.NUT, U	1	1	1	1	
15	95307-05700	.NUT	1	1	1	1	
16	93104-09025	.OIL SEAL	1	1	1	1	
17	1NV-26304-00	.SPRING	1	1	1	1	
18	4KB-2628G-00	.GASKET	1	1	1	1	
19	1NV-26129-00	.WASHER	1	1	1	1	
20	1NV-26398-00	.WASHER	1	1	1	1	
21	4V4-82913-00	HOLDER, LEVER LOWER 1	1	1	1	1	
22	98507-05020	SCREW, PAN HEAD	2	2	2	2	
23	92907-05600	WASHER, PLATE	2	2	2	2	
24	1P0-F6331-00	CABLE, STARTER 1	1	1	1	1	

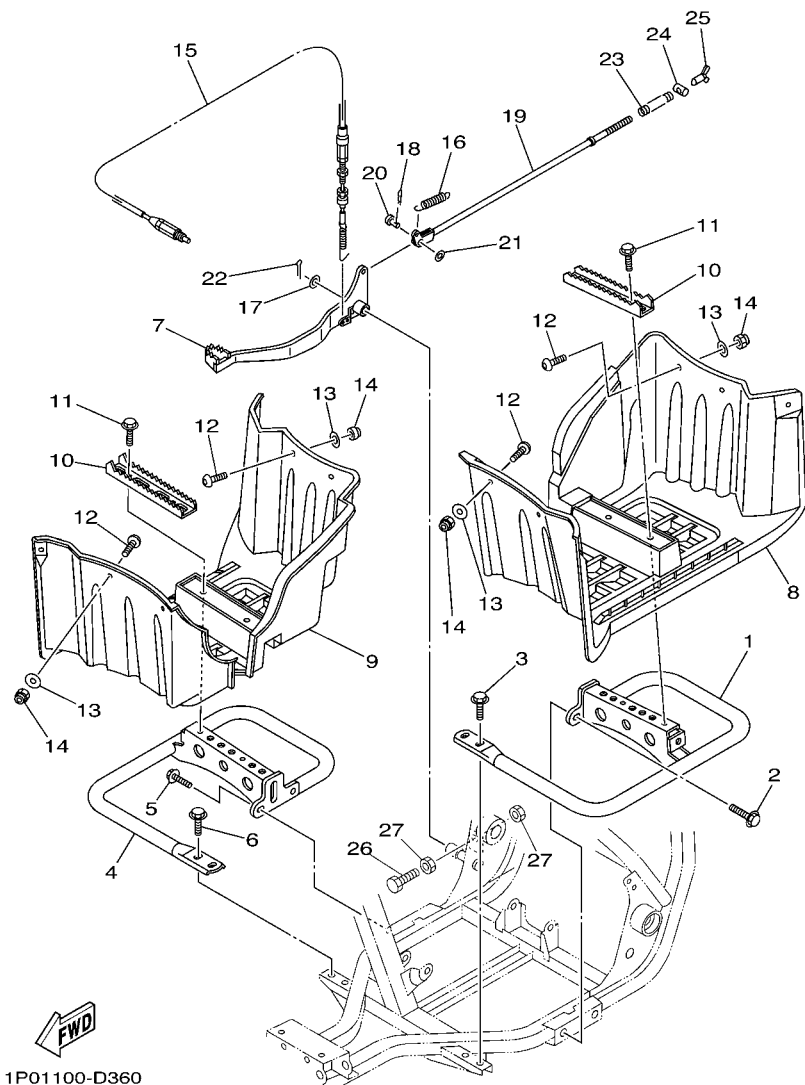


4XEL100-C350

FIG. 35 FRONT MASTER CYLINDER

REF. NO.	PART NO.	DESCRIPTION	USA	CAN	EUR	OCE	REMARKS
1	5KM-2583T-01	MASTER CYLINDER ASSY	1	1	1	1	
2	8CR-W0041-00	.CYLINDER KIT, MASTER	1	1	1	1	
3	4L0-25854-00	.DIAPHRAGM, RESERVOIR	1	1	1	1	
4	5JX-25852-01	.CAP, RESERVOIR	1	1	1	1	
5	98706-04012	.SCREW, FLAT HEAD	2	2	2	2	
6	5GH-25867-00	.BRACKET, MASTER CYLINDER	1	1	1	1	
7	5EB-26332-00	.BOLT	2	2	2	2	
8	5KM-83922-00	.LEVER 2	1	1	1	1	
9	95606-06100	.NUT, U	1	1	1	1	
10	5LP-83980-00	.FRONT STOP SWITCH ASSY	1	1	1	1	
11	1FK-2589F-00	.BOLT, LEVER	1	1	1	1	
12	4XE-F5872-00	HOSE, BRAKE 1	1	1	1	1	
13	4XE-F5873-00	HOSE, BRAKE 2	1	1	1	1	
14	4XE-F5871-00	PIPE, BRAKE	1	1	1	1	
15	95807-06025	BOLT, FLANGE	1	1	1	1	
16	90201-10118	WASHER, PLATE	6	6	6	6	
17	90401-10159	BOLT, UNION	3	3	3	3	
18	2GU-25866-00	CIRCLIP	1	1	1	1	
19	4XE-F612K-10	BRACKET 2	1	1	1	1	
20	97007-06016	BOLT	2	2	2	2	
21	92907-06600	WASHER, PLATE	2	2	2	2	
22	4XE-F587A-00	HOLDER, BRAKE HOSE	2	2	2	2	

FIG. 36 STAND & FOOTREST



REF. NO.	PART NO.	DESCRIPTION	USA	CAN	EUR	OCE	REMARKS
1	1P0-F7452-00	BRACKET, FOOTREST 1	1	1	1	1	
2	9581P-10020	BOLT, FLANGE	2	2	2	2	
3	9581P-08016	BOLT, FLANGE	2	2	2	2	
4	1P0-F7462-00	BRACKET, FOOTREST 2	1	1	1	1	
5	9581P-10020	BOLT, FLANGE	2	2	2	2	
6	9581P-08016	BOLT, FLANGE	2	2	2	2	
7	1P0-F7211-00	PEDAL, BRAKE	1	1	1	1	
8	1P0-F7453-00	COVER 1	1	1	1	1	
9	1P0-F7463-00	COVER 2	1	1	1	1	
10	1P0-F741A-00	ARM 1	2	2	2	2	
11	9581P-06016	BOLT, FLANGE	4	4	4	4	
12	90149-05299	SCREW	12	12	12	12	
13	90201-05029	WASHER, PLATE	12	12	12	12	
14	95707-05300	NUT, FLANGE	12	12	12	12	
15	1P0-2637F-00	CABLE, CONTROL 2	1	1	1	1	
16	90506-18224	SPRING, TENSION	1	1	1	1	
17	90201-15797	WASHER, PLATE	1	1	1	1	
18	91401-40030	PIN, COTTER	1	1	1	1	
19	4XE-27231-00	ROD, BRAKE	1	1	1	1	
20	90240-06076	PIN, CLEVIS	1	1	1	1	
21	92907-06200	WASHER	1	1	1	1	
22	91401-20012	PIN, COTTER	1	1	1	1	
23	90501-10245	SPRING, COMPRESSION	1	1	1	1	
24	90249-12008	PIN	1	1	1	1	
25	20E-26343-00	NUT, ADJUSTING	1	1	1	1	
26	97017-06020	BOLT	1	1	1	1	
27	95317-06700	NUT	2	2	2	2	

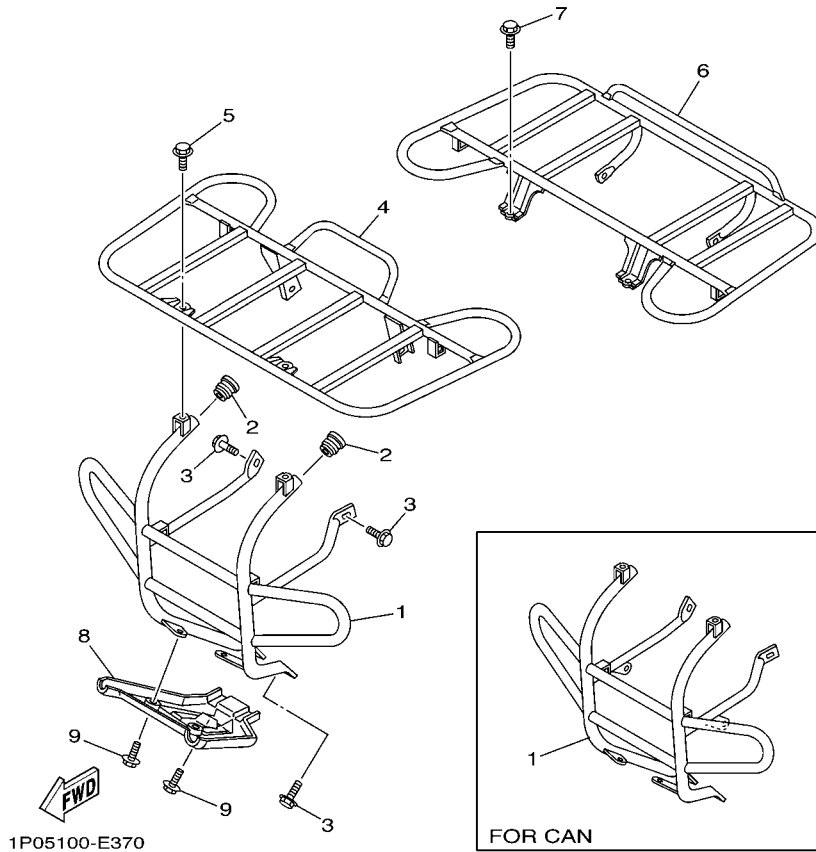
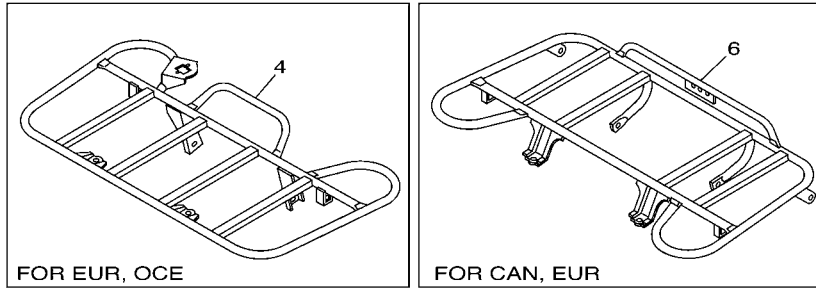


FIG. 37 GUARD

REF. NO.	PART NO.	DESCRIPTION	USA	CAN	EUR	OCE	REMARKS
1	1P0-F845N-00	BAR, CARRY FRONT	1		1	1	
	1P0-F845N-10	BAR, CARRY FRONT		1			
2	4XE-F1399-00	CAP	2	2	2	2	
3	9581P-08016	BOLT, FLANGE	6	6	6	6	
4	1P0-F4841-00	CARRIER, FRONT	1	1			
	1P0-F4841-10	CARRIER, FRONT			1	1	
5	9581P-08012	BOLT, FLANGE	2	2	2	2	
6	1P0-F4842-00	CARRIER, REAR	1			1	
	1P0-F4842-10	CARRIER, REAR		1	1		
7	9581P-08016	BOLT, FLANGE	4	4	4	4	
8	1P0-F842M-00	COVER 1	1	1	1	1	
9	90109-063F1	BOLT	3	3	3	3	









# PARTS NEWS

News No. PE0-MC-080040

Date: July, 4., 2008

Signature: K. Otsuka

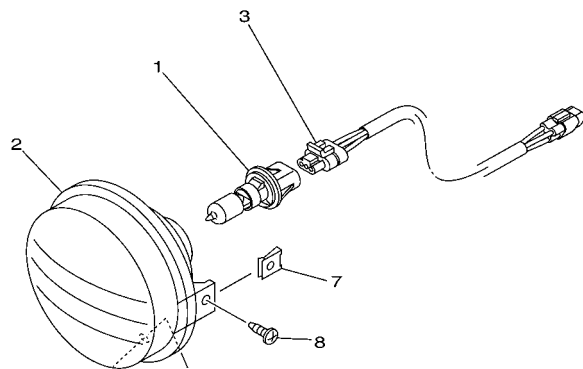
 Cause  Revision Notice  Correction  Sales Unit Change  Others

Model	See the "List of Models and CATALOGUE No's below."
Subject	PARTS CATALOGUE CORRECTIONS
CATALOGUE NO.	See the "List of Models and CATALOGUE No's below."
Time of YPEC Revision	Text, Illustration --> Jul./22/2008 PDF Replace --> Jul./22/2008 (YPEC = Yamaha Parts Electrical Catalogue = Website parts catalogue )

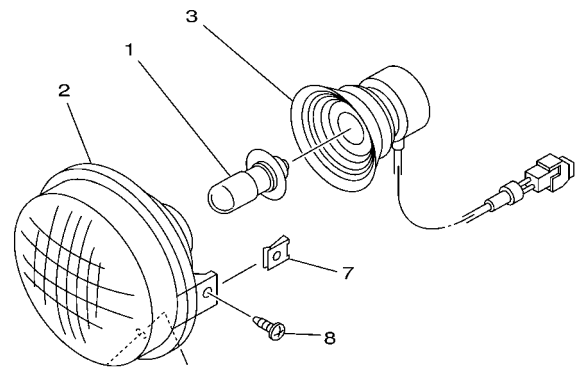
## 1. ILLUSTRATION CORRECTION

### FIG.40 or 45 HEADLIGHT SECTION

(OLD)



(NEW)



## 2. LIST CORRECTION

### FIG.40 or 45 HEADLIGHT SECTION

Ref.No.	OLD PART No.	NEW PART No.	PART NAME	Q'TY	INTERCHANGE ABILITY	REMARKS
1	5FU-H4314-10	<b>4KB-84314-01</b>	BULB, HEADLIGHT(12V-30/30W)	2	○	<b>Illustration &amp; Part number revision</b>
2	5FU-H4320-10	<b>5KM-84320-01</b>	LENS ASSY	2	○	
3	5FU-H4340-10	<b>5EH-84340-00</b>	SOCKET CORD ASSY 1	2	○	

\* The parts marked with ○ indicates interchangeability with a set.

## 3. LIST of Models and CATALOGUE No's.

The applicable MODELS, MODEL CODES, and CATALOGUE No's are as follows.

MODEL YEAR	MODEL NAME	MODEL CODE	CATALOGUE NO.
2007	YFM25BW/ W	1P09/ 1P0A/ 1P0B/ 1P0C	1F1P0-100E1
2007	YFM4FGW/ FAW	1P19/ 1P1A/ 1P1B	1F1P1-100E1
2007	YFM4FGW	1P1C	1F1P1-110E1
2007	YFM45FGW/ FAW	1D9M/ 1D9N/ 1D9P/ 1D9R	1F1D9-100E1
2007	YFM45FGW/ FAW	1D9S/ 1D9T/ 1D9U	1F1D9-100EA

Thank you very much for your cooperation.

 Parts  
 Manager  
 Check

 Service  
 Manager  
 Check

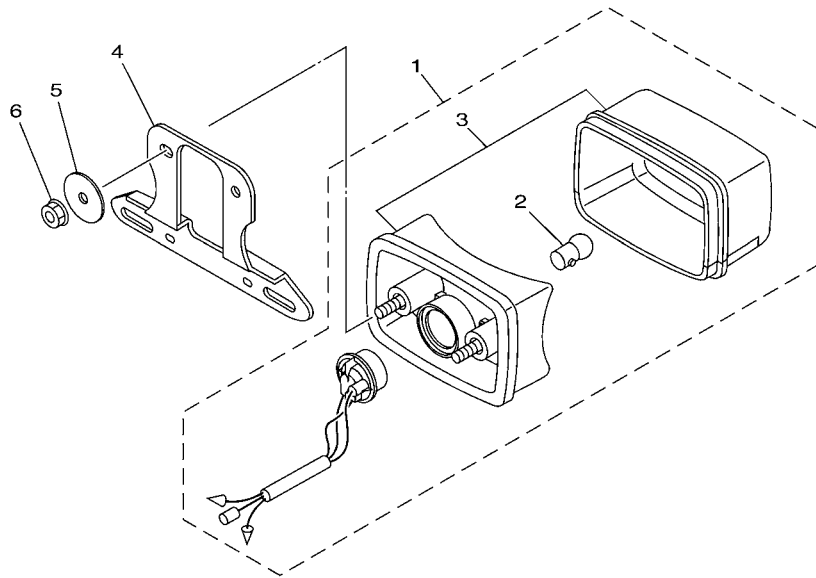
 Parts  
 Manager  
 File

 YAMAHA MOTOR CO.,LTD  
 2500 Shingai Iwata Shizuoka 438-8501.Japan  
 Technical Publication Dept.



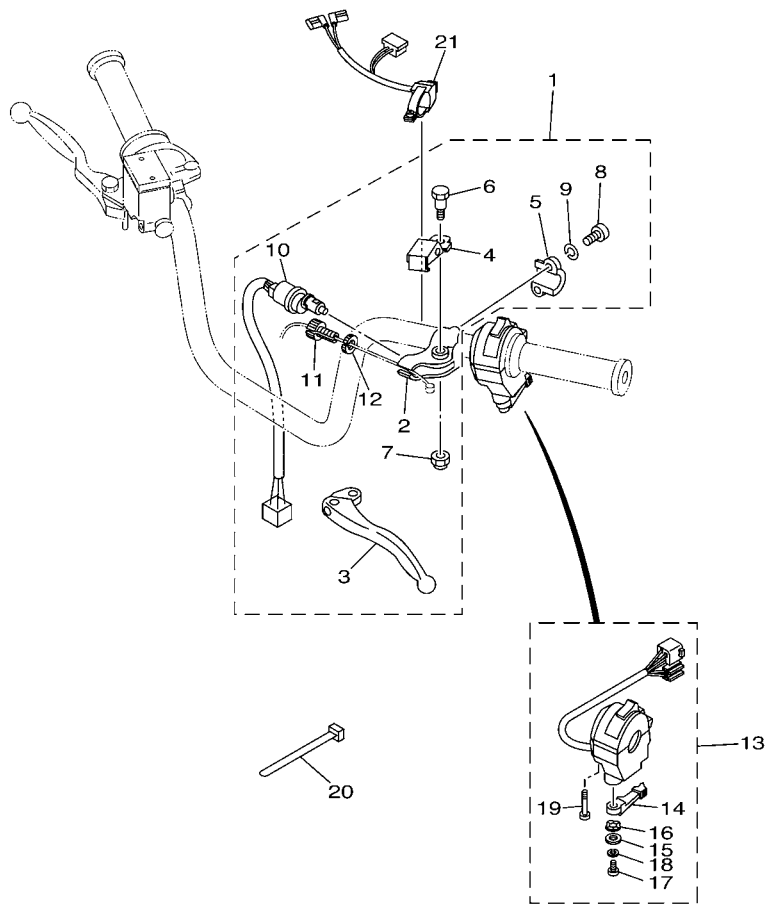
FIG. 42 TAILLIGHT 2

REF. NO.	PART NO.	DESCRIPTION	USA	CAN	EUR	OCE	REMARKS
1	5KM-84710-00	TAILLIGHT UNIT ASSY		1			
2	1A2-84714-41	.BULB (12V-21/5W)		1			
3	5KM-8472C-10	.LENS, CP.		1			
4	90201-06074	WASHER, PLATE		2			
5	95707-06300	NUT, NYLON		2			
6	5GH-84751-10	BRACKET, LICENSE		1			



5ND1100-3470

FIG. 43 HANDLE SWITCH & LEVER



REF. NO.	PART NO.	DESCRIPTION	USA	CAN	EUR	OCE	REMARKS
1	5FU-82910-23	LEVER HOLDER ASSY (LEFT)	1	1	1	1	
2	1YW-82911-02	.HOLDER, LEVER 1	1	1	1	1	
3	2HT-83912-00	.LEVER 1	1	1	1	1	
4	1YW-83965-00	.LEVER, LOCK	1	1	1	1	
5	2XJ-82913-00	.HOLDER, LEVER LOWER 1	1	1	1	1	
6	90109-06576	.BOLT	1	1	1	1	
7	95607-06100	.NUT, U	1	1	1	1	
8	98507-06020	.SCREW, PAN HEAD	2	2	2	2	
9	92907-06100	.WASHER, SPRING	2	2	2	2	
10	3FA-83980-03	.FRONT STOP SWITCH ASSY	1	1	1	1	
11	90123-08046	.BOLT	1	1	1	1	
12	90179-08148	.NUT	1	1	1	1	
13	5LP-83973-01	SWITCH, HANDLE 3	1	1	1	1	
14	5GH-83941-00	.LEVER, STARTER	1	1	1	1	
15	1UY-83909-00	.WASHER, SPECIAL	1	1	1	1	
16	3L4-83943-00	.WASHER, STARTER	1	1	1	1	
17	98517-05012	.SCREW, PAN HEAD	1	1	1	1	
18	92907-05100	.WASHER, SPRING	1	1	1	1	
19	98507-05030	.SCREW, PAN HEAD	2	2	2	2	
20	90464-31827	CLAMP	3	3	3	3	
21	1C5-83976-00	SWITCH, HANDLE 1			1	1	

  
1P03300-D420

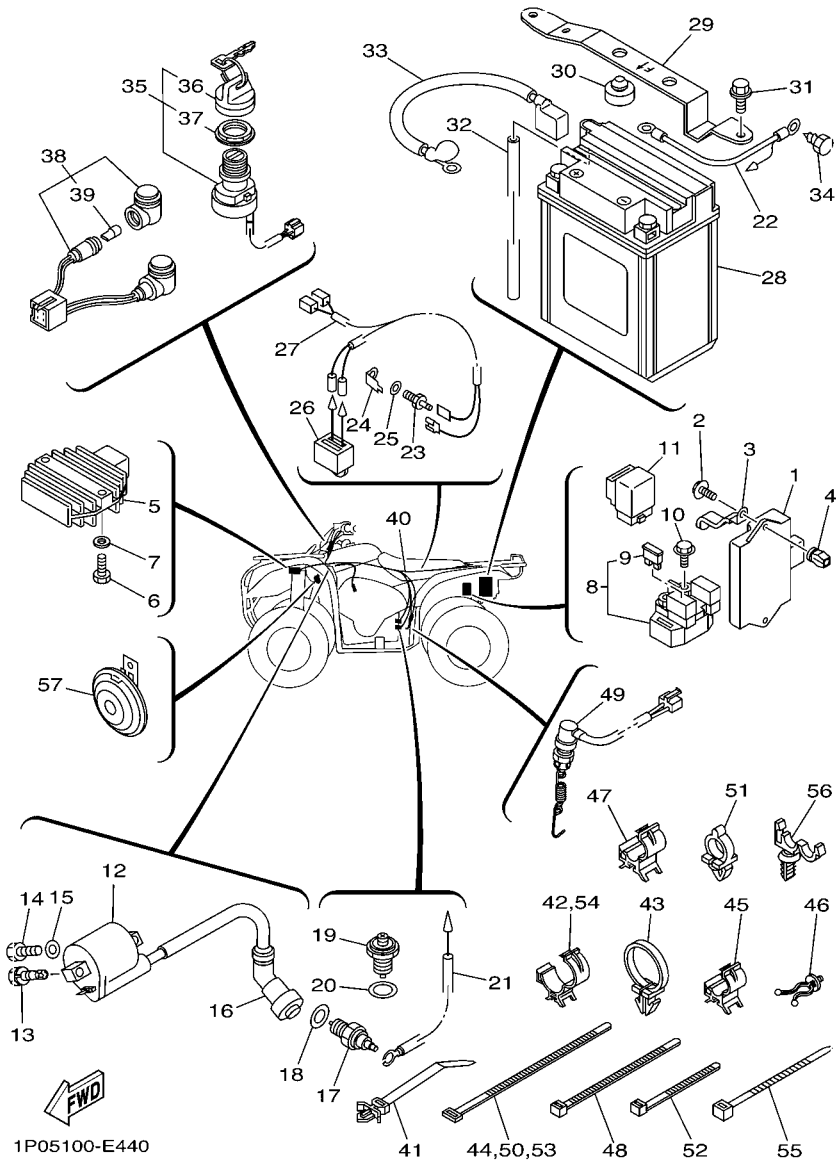


FIG. 44 ELECTRICAL 1

REF. NO.	PART NO.	DESCRIPTION	USA	CAN	EUR	OCE	REMARKS
1	1P0-85540-00	C.D.I. UNIT ASSY	1	1	1	1	
2	97707-60420	SCREW, TAPPING	1	1	1	1	
3	90462-06016	CLAMP	1	1	1	1	
4	90338-08226	PLUG	1	1	1	1	
5	5GT-81960-00	RECTIFIER & REGULATOR ASSY	1	1	1	1	
6	97007-06020	BOLT	2	2	2	2	
7	92907-06600	WASHER, PLATE	2	2	2	2	
8	4XE-81940-12	STARTER RELAY ASSY	1	1	1	1	
9	2GH-82151-00	.FUSE (20A-BL)	2	2	2	2	
10	9502P-06008	BOLT, FLANGE	2	2	2	2	
11	1RL-81950-92	RELAY ASSY	1	1	1	1	
12	4KJ-82310-10	IGNITION COIL ASSY	1	1	1	1	
13	90109-06873	BOLT	1	1	1	1	
14	97007-06020	BOLT	1	1	1	1	
15	92907-06600	WASHER, PLATE	1	1	1	1	
16	1UY-82370-20	PLUG CAP ASSY	1	1	1	1	
17	3GB-82540-01	NEUTRAL SWITCH ASSY	1	1	1	1	
18	90430-10148	GASKET	1	1	1	1	
19	4KD-82540-00	NEUTRAL SWITCH ASSY	1	1	1	1	
20	90201-12790	WASHER, PLATE	1	1	1	1	
21	5XG-H2507-00	WIRE, LEAD	1	1	1	1	
22	1P0-H2116-00	WIRE, MINUS LEAD	1	1	1	1	
23	5FU-83790-00	HEATER ASSY (15W)			1	1	AP
24	5FU-82103-00	TERMINAL 1			1	1	AP
25	90201-08016	WASHER, PLATE			1	1	AP
26	5FU-82560-20	THERMO SWITCH ASSY			1	1	AP
27	4XE-82509-10	WIRE, SUB LEAD			1	1	AP

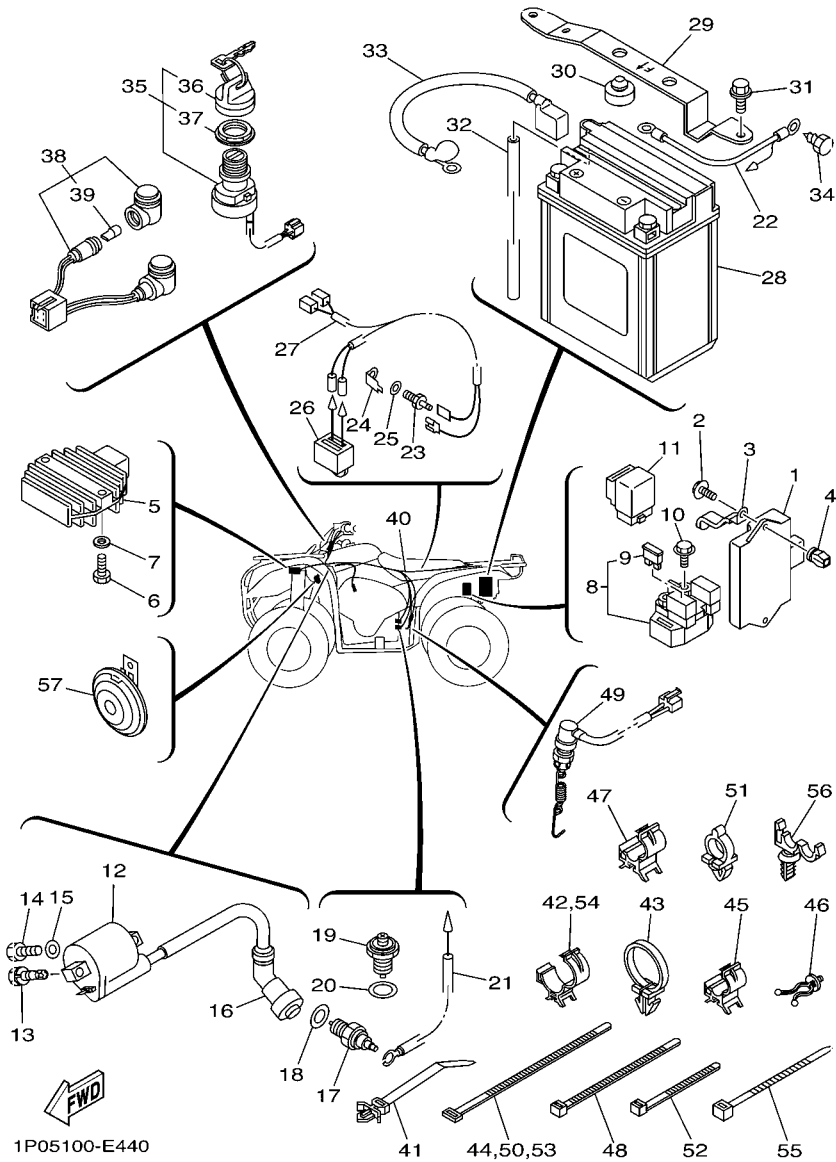


FIG. 44 ELECTRICAL 1

REF. NO.	PART NO.	DESCRIPTION	USA	CAN	EUR	OCE	REMARKS
28	4XE-H2100-20	BATTERY ASSY (GS CB14A-A2)	1	1	1	1	
29	1P0-H2128-00	BRACKET, BATTERY	1	1	1	1	
30	5TG-82121-10	PAD, BATTERY	2	2	2	2	
31	95807-06020	BOLT, FLANGE	2	2	2	2	
32	1P0-H2112-00	PIPE, BREATHER	1	1	1	1	
33	1P0-H2115-00	WIRE, PLUS LEAD	1	1	1	1	
34	9770P-60416	SCREW, TAPPING	1	1	1	1	
35	4XE-82510-00	MAIN SWITCH ASSY	1	1	1	1	
36	3HN-82579-00	.CAP, KEY	1	1	1	1	
37	3HN-82569-00	.NUT, MAIN SWITCH	1	1	1	1	
38	5TE-83530-00	PILOT LIGHT ASSY	1	1	1	1	
39	5GH-83516-00	.BULB (14V-1.7W)	2	2	2	2	
40	1P0-82590-00	WIRE HARNESS ASSY	1	1			
	1P0-82590-10	WIRE HARNESS ASSY			1	1	
41	90464-25800	CLAMP	1	1	1	1	
42	90464-20835	CLAMP	1	1	1	1	
43	90464-19815	CLAMP	1	1	1	1	
44	90464-48837	CLAMP	2	2	2	2	
45	90464-08834	CLAMP	5	5	5	5	
46	90464-12836	CLAMP	1	1	1	1	
47	90464-10842	CLAMP	3	3	3	3	
48	90464-40825	CLAMP	2	2	2	2	
49	4XE-82530-10	STOP SWITCH ASSY	1	1	1	1	
50	90464-48837	CLAMP	2	2	2	2	
51	90464-10833	CLAMP	2	2	2	2	
52	90464-31827	CLAMP	2	2	2	2	
53	90464-48837	CLAMP	1	1	1	1	

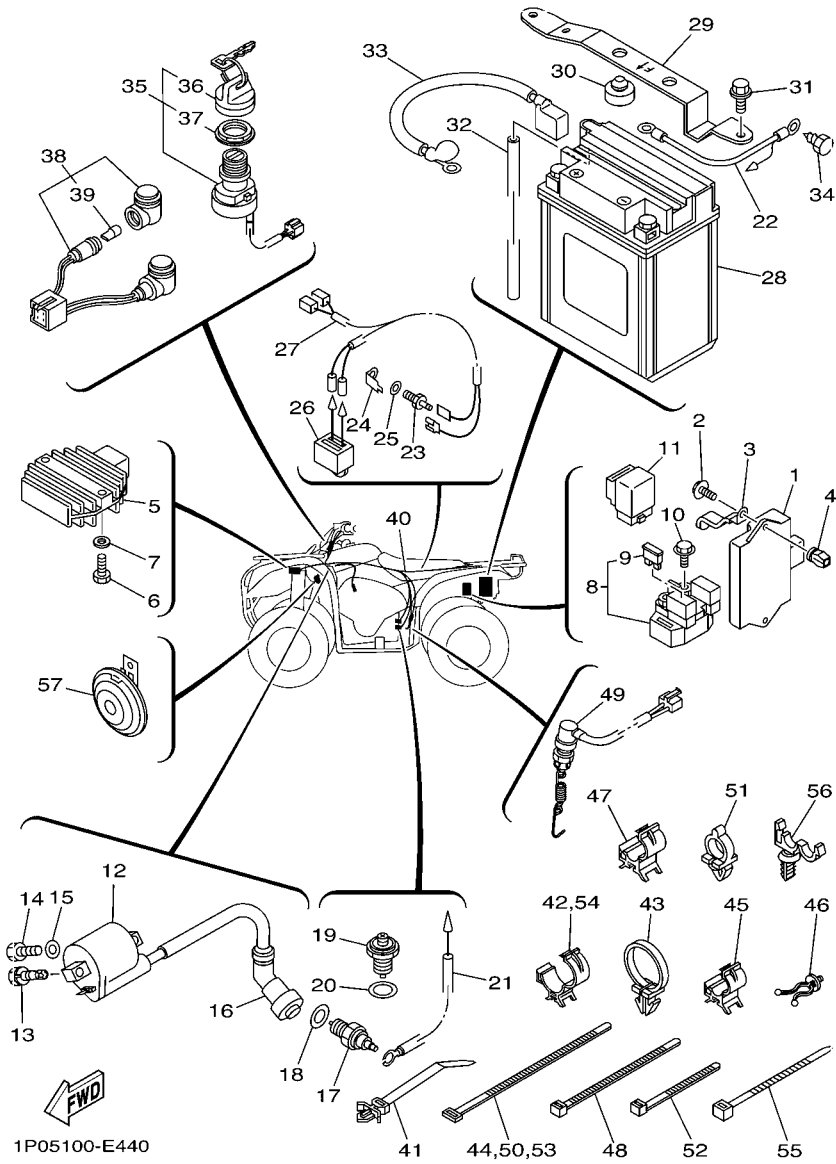


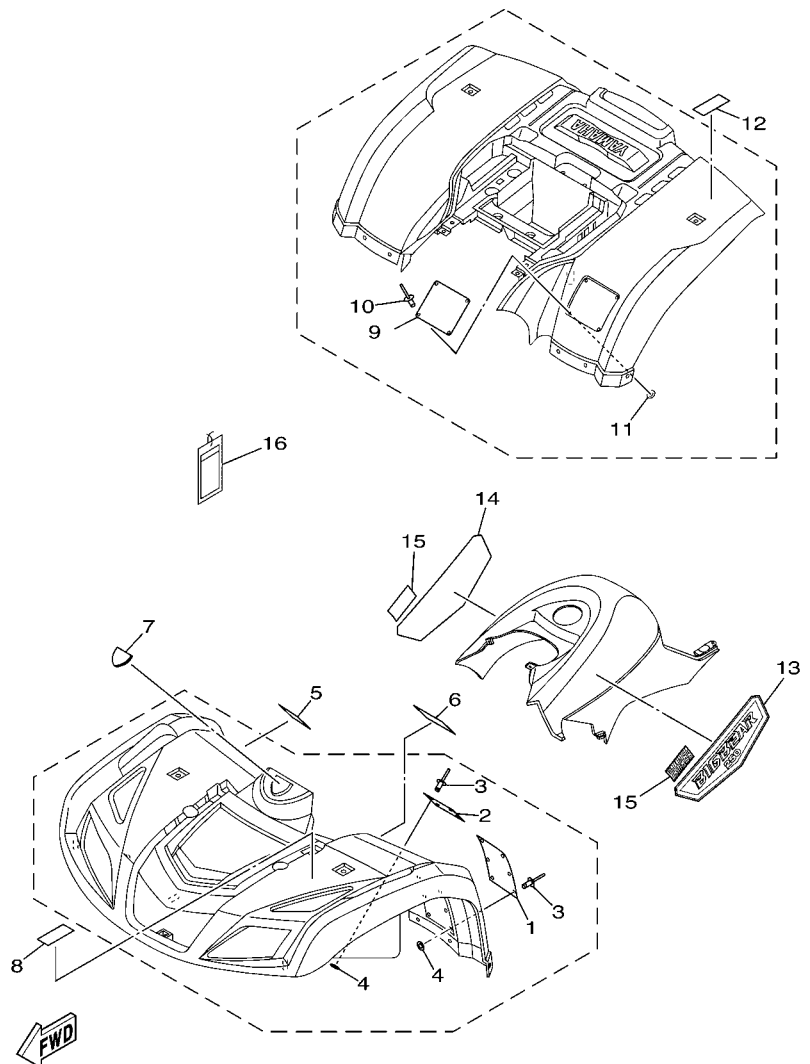
FIG. 44 ELECTRICAL 1

REF. NO.	PART NO.	DESCRIPTION	USA	CAN	EUR	OCE	REMARKS
54	90464-20835	CLAMP	1	1	1	1	
55	90464-31827	CLAMP	1	1	1	1	
56	90464-12830	CLAMP	1	1	1	1	
57	4WV-83371-00	HORN			1	1	
-----							
-----							
-----							
-----							
-----							
-----							
-----							
-----							
-----							
-----							





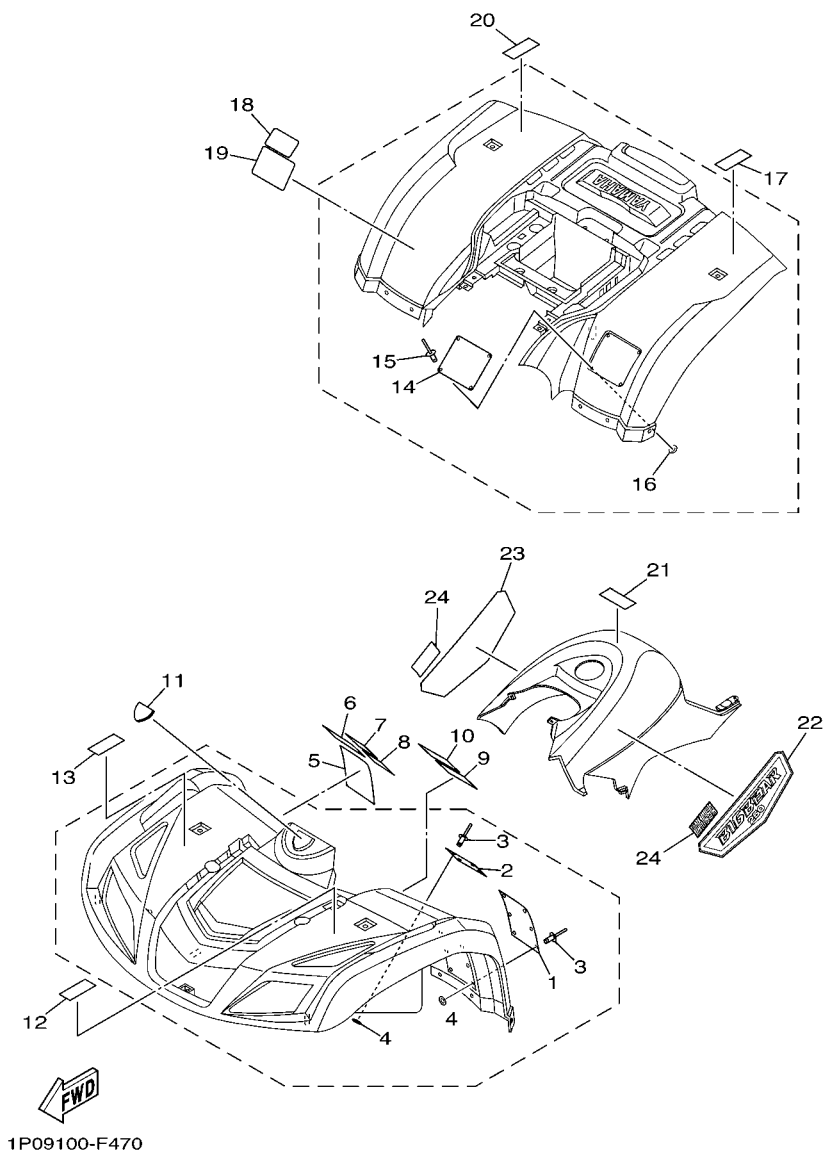
FIG. 46 EMBLEM & LABEL 1



1P09100-F460

REF. NO.	PART NO.	DESCRIPTION	USA	CAN	EUR	OCE	REMARKS
1	4XE-F1568-00	LABEL, WARNING	1				ENGLISH
2	4XE-F415A-00	LABEL, CAUTION	1				ENGLISH
3	4XE-F1539-10	RIVET	10				
4	4XE-F1549-00	WASHER, FENDER MOLD	10				
5	4XE-F1578-00	EMBLEM	1				
6	4XE-F151E-01	LABEL 2	1				ENGLISH
7	3B4-26232-00	EMBLEM 3D	1				
8	4XE-F4877-30	LABEL, CAUTION	1				
9	4XE-F1696-00	LABEL, CAUTION	1				ENGLISH
10	4XE-F1539-10	RIVET	4				
11	4XE-F1549-00	WASHER, FENDER MOLD	4				
12	4XE-F4897-30	EMBLEM	1				
13	1P0-F1781-C0	EMBLEM 1	1				
14	1P0-F1782-C0	EMBLEM 2	1				
15	5UH-F173B-00	EMBLEM 3D	2				
16	4XE-F819R-10	TAG, WARNING	1				

FIG. 47 EMBLEM & LABEL 2



REF. NO.	PART NO.	DESCRIPTION	USA	CAN	EUR	OCE	REMARKS
1	4XE-F1568-00	LABEL, WARNING		1			ENGLISH
2	4XE-F415A-00	LABEL, CAUTION		1			ENGLISH
3	4XE-F1539-10	RIVET		10			
4	4XE-F1549-00	WASHER, FENDER MOLD		10			
5	4XE-F1568-20	LABEL, WARNING		1			FRENCH
6	4XE-F415A-10	LABEL, CAUTION		1			FRENCH
7	4XE-F1578-00	EMBLEM		1			
8	4XE-F1578-10	EMBLEM		1			
9	4XE-F151E-01	LABEL 2		1			ENGLISH
10	4XE-F151E-11	LABEL 2		1			FRENCH
11	3B4-26232-00	EMBLEM 3D		1			
12	4XE-F4877-30	LABEL, CAUTION		1			
13	4XE-F4877-40	LABEL, CAUTION		1			
14	4XE-F1696-00	LABEL, CAUTION		1			ENGLISH
15	4XE-F1539-10	RIVET		4			
16	4XE-F1549-00	WASHER, FENDER MOLD		4			
17	4XE-F4897-30	EMBLEM		1			
18	4XE-F151H-10	LABEL 5		1			FRENCH
19	4XE-F1696-10	LABEL, CAUTION		1			FRENCH
20	4XE-F4897-40	EMBLEM		1			
21	4XE-F416E-00	LABEL, CAUTION CANADA		1			
22	1P0-F1781-C0	EMBLEM 1		1			
23	1P0-F1782-C0	EMBLEM 2		1			
24	5UH-F173B-00	EMBLEM 3D		2			

FIG. 48 EMBLEM & LABEL 3

REF. NO.	PART NO.	DESCRIPTION	USA	CAN	EUR	OCE	REMARKS
1	4XE-F1568-50	LABEL, WARNING			1		
2	4XE-F415A-20	LABEL, CAUTION			1		
3	4XE-F1539-10	RIVET			10		
4	4XE-F1549-00	WASHER, FENDER MOLD			10		
5	3B4-26232-00	EMBLEM 3D			1		
6	4XE-F4877-20	LABEL, CAUTION			1		ENGLISH
7	1P0-F155A-00	MARK, CE			1		
8	4XE-F1696-20	LABEL, CAUTION			1		FRENCH
9	4XE-F1539-10	RIVET			4		
10	4XE-F1549-00	WASHER, FENDER MOLD			4		
11	4XE-F4897-20	EMBLEM			1		ENGLISH
12	1P0-F1781-C0	EMBLEM 1			1		
13	1P0-F1782-C0	EMBLEM 2			1		
14	5UH-F173B-00	EMBLEM 3D			2		
15	4XE-F415E-10	LABEL, CAUTION			1		

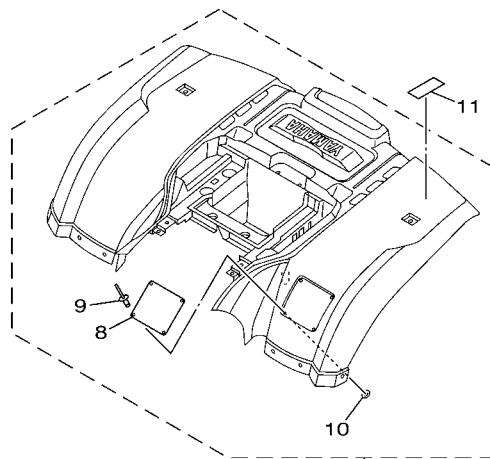


FIG.22-1

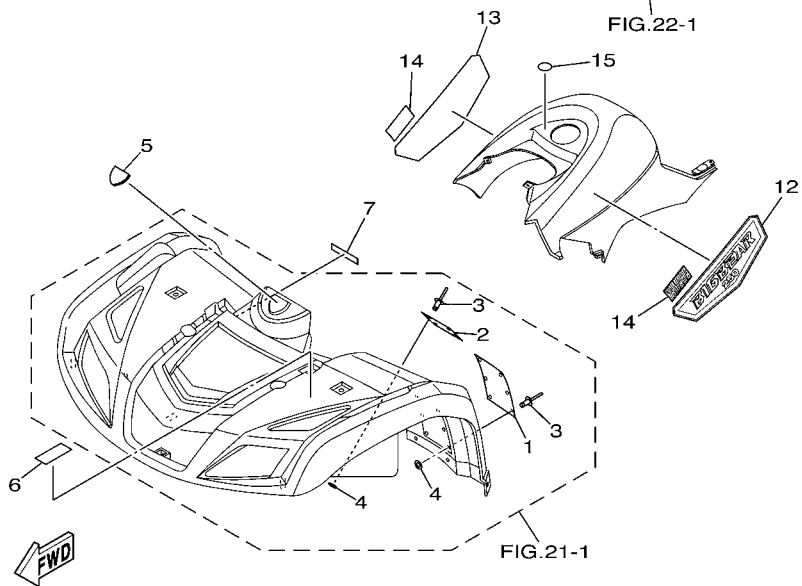


FIG.21-1

1P09100-F480

FIG. 49 EMBLEM & LABEL 4

REF. NO.	PART NO.	DESCRIPTION	USA	CAN	EUR	OCE	REMARKS
1	4XE-F1568-10	LABEL, WARNING				1	ENGLISH
2	4XE-F415A-00	LABEL, CAUTION				1	ENGLISH
3	4XE-F1539-10	RIVET				10	
4	4XE-F1549-00	WASHER, FENDER MOLD				10	
5	3B4-26232-00	EMBLEM 3D				1	
6	4XE-F4877-20	LABEL, CAUTION				1	ENGLISH
7	4XE-F1696-00	LABEL, CAUTION				1	ENGLISH
8	4XE-F1539-10	RIVET				4	
9	4XE-F1549-00	WASHER, FENDER MOLD				4	
10	4XE-F4897-20	EMBLEM				1	ENGLISH
11	1P0-F1781-C0	EMBLEM 1				1	
12	1P0-F1782-C0	EMBLEM 2				1	
13	5UH-F173B-00	EMBLEM 3D				2	

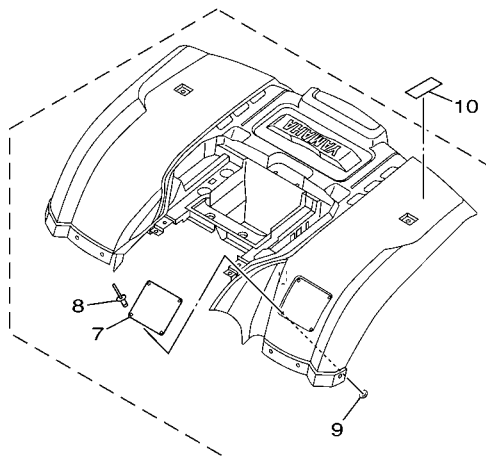


FIG.22-1

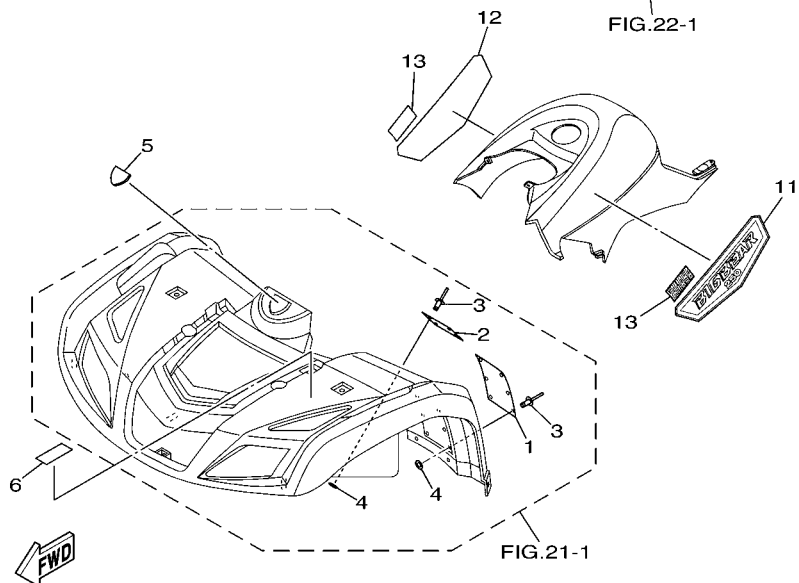


FIG.21-1

1P09100-F490

NUMERICAL INDEX

PART NO.	GRID NO.	PART NO.	GRID NO.	PART NO.	GRID NO.	PART NO.	GRID NO.	PART NO.	GRID NO.	PART NO.	GRID NO.
5H0-11133-11	B - 2	4BE-14613-00	B - 13	1P0-18300-01	C - 10	4XE-27231-00	E - 5	5KM-8472C-10	E - 11	4XE-E442F-00	B - 9
4XE-11166-00	B - 2	3YF-14714-00	B - 13	52G-18540-01	C - 12	1NV-2811A-01	C - 14	5GH-84751-10	E - 11	4XE-E4437-00	B - 9
3GH-11181-00	B - 2	5EL-1490H-00	B - 12	5GH-18617-00	C - 10	29U-46125-00	D - 5	2EK-85111-00	F - 2	4XE-E4438-00	B - 9
214-11198-01	D - 5	5ND-1490H-00	B - 12	1P0-2177C-00	B - 9	4X7-46180-00	D - 7	3Y6-85130-02	F - 2	4XE-E4450-00	B - 9
5VC-11351-00	B - 4	1P0-1490J-00	B - 11	1W1-22128-00	D - 8	1EV-81823-00	E - 8	449-85131-02	F - 2	1P0-E4453-00	B - 9
4BD-11631-00-Y0	B - 5	5GH-14918-10	B - 11	29U-22189-00	D - 4	4XE-81940-12	E - 13	1P0-85540-00	E - 13	4XE-E4457-00	B - 9
4BD-11636-00	B - 5	5DM-14933-00	B - 11	2HR-23526-00	D - 9	1RL-81950-92	E - 13	5XG-E1102-01	B - 2	4XE-E4462-00	B - 9
4BD-11638-00	B - 5	4XE-14937-00	B - 12	1UY-23812-00	D - 10	5GT-81960-00	E - 13	3UR-E111F-00	B - 3	4XE-E4611-10	B - 13
4G0-12113-01	B - 7	5GH-14937-00	B - 12	8K1-23814-00	D - 10	5FU-82103-00	E - 13	5XG-E1160-01	B - 2	4XE-E4612-10	B - 13
4G0-12114-01	B - 7	5GH-14940-10	B - 11	1P0-24311-00	D - 11	5TG-82121-10	E - 14	5XG-E1161-00	B - 2	4XE-E4628-00	B - 13
4G0-12116-01	B - 7	256-14956-01	B - 12	4BD-24339-00	D - 11	2GH-82151-00	E - 13	5XG-E1162-00	B - 2	4XE-E4710-20	B - 13
4G0-12117-00	B - 7	3H1-14962-00	B - 11	3JN-24500-02	D - 11	4KJ-82310-10	E - 13	5XG-E1165-00	B - 2	4XE-E4767-00	B - 13
4G0-12118-00	B - 7	5DM-14985-00	B - 12	4X8-24512-00	D - 11	1UY-82370-20	E - 13	5XG-E1186-00	B - 2	5XG-E5150-00	B - 14
5H0-12119-00	B - 7	7T9-14987-00	B - 12	3AJ-24534-01	D - 11	4XE-82509-10	E - 13	5XG-E1187-00	B - 2	5XG-E5317-00	B - 15
2NX-12159-00	B - 7	2N4-15371-00	D - 5	5KM-24610-00	D - 11	4XE-82510-00	E - 14	5XG-E1310-00	B - 4	5XG-E5351-00	B - 10
3GC-12210-10	B - 8	4BD-15451-01	B - 15	1UY-25117-00	D - 13	4XE-82530-10	E - 14	5XG-E1400-00	B - 5	5XG-E5362-00	B - 15
4FM-12213-00	B - 8	4BD-15462-00	B - 15	52H-2512A-00	D - 13	4KD-82540-00	E - 13	5XG-E1422-00	B - 5	5XG-E5381-00	C - 2
4BE-13329-01	B - 10	4BD-15463-01	B - 15		E - 2	3GB-82540-01	E - 13	5XG-E1454-00	B - 5	5XG-E5431-00	B - 15
51Y-13411-00	B - 10	31A-15580-00	C - 4	4SH-25367-01	D - 15	5FU-82560-20	E - 13	5XG-E1531-00	B - 5	5XG-E5499-00	B - 15
1P0-13586-00	B - 9	1J7-15583-01	C - 4	3GD-2580T-00	D - 14	3HN-82569-00	E - 14	5XG-E1536-00	B - 5	1P0-E5512-00	C - 4
5UH-14103-00	B - 12	21V-15719-00	B - 15	3GD-2580U-00	D - 14	3HN-82579-00	E - 14	5XG-E1603-00	B - 5	5XG-E5517-00	C - 4
5FU-14105-10	B - 11	21V-16358-00	C - 5	3GD-25827-00	D - 14	1P0-82590-00	E - 14	5XG-E1605-00	B - 5	5XG-E5521-00	C - 4
1P0-14107-20	B - 11	21V-16664-00	C - 5	3GD-25828-00	D - 14	1P0-82590-10	E - 14	5XG-E1607-00	B - 5	4XE-E5710-00	C - 3
4KM-14107-20	B - 11	24W-17151-02	C - 6	5KM-2583T-01	E - 4	5FU-82910-23	E - 12	5XG-E1633-00	B - 5	4XE-E5711-00	C - 3
5UH-1410A-00	B - 11	4BD-17251-00	C - 6	5JX-25852-01	E - 4	1YW-82911-02	E - 12	5XG-E1651-00	B - 5	4XE-E5713-00	C - 3
5DM-14112-00	B - 11	52G-17531-01	C - 7	4L0-25854-00	E - 4	2XJ-82913-00	E - 12	3UR-E1681-00	B - 5	4XE-E5714-00	C - 3
5DM-14141-42	B - 11	52G-17531-11	C - 7	2GU-25866-00	E - 4	4V4-82913-00	E - 3	5XG-E2111-00	B - 7	4XE-E5715-00	C - 3
4KM-14142-17	B - 12	52G-17531-21	C - 7	5GH-25867-00	E - 4	4WV-83371-00	E - 15	5XG-E2121-00	B - 7	4XE-E5716-00	C - 3
3H1-14147-00	B - 11	52G-17531-31	C - 7	1FK-2589F-00	E - 4	5GH-83516-00	E - 14	3UR-E2146-00	B - 7	5XG-E5723-00	C - 3
3G2-1414E-37	B - 11	52G-17531-41	C - 7	3GD-25933-00	D - 14	5TE-83530-00	E - 14	5XG-E2151-00	B - 7	4XE-E5741-00	C - 3
522-14161-00	B - 12	52G-17531-51	C - 7	1NV-26129-00	E - 3	5FU-83790-00	E - 13	3UR-E2156-00	B - 7	4XE-E5744-00	C - 3
5FU-14167-00	B - 12	24W-17537-10	C - 7	3B4-26232-00	F - 3	1UY-83909-00	E - 12	5XG-E2171-00	B - 8	4XE-E5751-00	C - 3
127-14186-00	B - 11	24W-17537-20	C - 7		F - 4	2HT-83912-00	E - 12	5XG-E2176-00	B - 8	4XE-E5755-00	C - 3
3FV-14191-00	B - 11	24W-17537-30	C - 7		F - 5	5KM-83922-00	E - 4	3UR-E2231-00	B - 8	4XE-E5767-00	C - 3
24W-14193-00	B - 12	24W-17537-40	C - 7		F - 6	5GH-83941-00	E - 12	5XG-E2241-00	B - 8	4XE-E5779-00	C - 3
4KB-14193-20	B - 11	24W-17537-50	C - 7	4KB-26250-10	E - 3	3L4-83943-00	E - 12	5XG-E3300-00	B - 10	5XG-E5787-00	B - 15
5FU-14197-00	B - 12	24W-17537-60	C - 7	1NV-2625G-01	E - 3	1YW-83965-00	E - 12	5XG-E3326-00	B - 10	4XE-E5789-00	C - 3
3DM-14216-00	B - 12	52G-17967-20	C - 7	4KB-2628F-10	E - 3	5LP-83973-01	E - 12	3UH-E3440-00	B - 10	4XE-E5793-00	C - 3
4KM-14216-00	B - 11	52G-17967-30	C - 7	4KB-2628G-00	E - 3	1C5-83976-00	E - 12	5XG-E3447-00	B - 10	5XG-E6150-00	C - 5
3G2-14231-12	B - 11	52G-17967-40	C - 7	1NV-26304-00	E - 3	5LP-83980-00	E - 4	1P0-E4101-01	B - 11	5XG-E6154-00	C - 5
1HX-14231-16	B - 11	24W-18104-00	C - 13	1P0-26311-00	E - 3	3FA-83980-03	E - 12	1P0-E4101-10	B - 11	5XG-E6321-00	C - 5
5DM-14261-00	B - 11	1P0-18110-00	C - 13	5EB-26332-00	E - 4	2GU-84332-00	E - 9	5FU-E4147-00	B - 11	5XG-E6324-00	C - 5
5UH-14348-00	B - 12	22N-18113-00	C - 13	1P0-26341-00	E - 3	2GU-84334-00	E - 9	5FU-E4155-00	B - 12	5XG-E6351-00	C - 5
31A-14419-00	B - 9	5GH-18131-00	C - 10	20E-26343-00	E - 3	5KM-84710-00	E - 10	5ND-E4191-00	C - 10	5XG-E6352-00	C - 5
5BF-1443E-00	D - 2	1P0-18174-00	C - 10		E - 5		E - 11	5UH-E4349-00	B - 9	5XG-E6371-00	C - 5
583-14561-00	B - 11	24W-18179-00	C - 13	1P0-2637F-00	E - 5	1A2-84714-41	E - 10	4XE-E4411-00	B - 9	5XG-E6611-00	C - 5
5DM-14561-00	B - 11	21V-18181-00	C - 13	1NV-26398-00	E - 3		E - 11	4XE-E4412-00	B - 9	5XG-E6620-00	C - 5
1FN-14565-00	B - 12	52G-18187-00	C - 10	109-27114-00	D - 4	5KM-8472C-10	E - 10	JN6-E4424-00	B - 9	5XG-E6626-00	C - 5

NUMERICAL INDEX

PART NO.	GRID NO.	PART NO.	GRID NO.	PART NO.	GRID NO.	PART NO.	GRID NO.	PART NO.	GRID NO.	PART NO.	GRID NO.
5XG-E6665-00	C - 5	5XG-E8197-00	C - 8	1P0-F1600-00	D - 2	4XE-F3833-00	D - 10	5VH-F5351-00	D - 15	4XE-G6118-14	D - 6
5XG-E7121-00	C - 6	5XG-E8198-00	C - 8	1P0-F1600-10	D - 2	4XE-F3834-00	D - 10	1P0-F5355-00	D - 15	4XE-G6118-15	D - 6
5XG-E7131-00	C - 6	1P0-E8323-00	C - 8	1P0-F1600-20	D - 2	1D9-F3841-01	D - 10	5VH-F5359-00	D - 15	4XE-G6118-16	D - 6
5XG-E7141-00	C - 6	1P0-E8341-00	C - 10	1P0-F1600-30	D - 2	5ND-F3845-01	D - 10	5FU-F5377-10	E - 2	4XE-G6118-17	D - 6
5XG-E7211-00	C - 6	5XG-E8451-00	C - 8	1P0-F1600-40	D - 2	4XE-F3868-10	D - 10	5FU-F537Y-00	E - 2	4XE-G6118-18	D - 6
5XG-E7221-00	C - 6	5XG-E8511-00	C - 12	1P0-F1600-50	D - 2	4XE-F3894-00	D - 10	1P0-F5381-00	E - 2	4XE-G6118-19	D - 6
5XG-E7231-00	C - 6	5XG-E8512-00	C - 12	1P0-F1600-60	D - 2	4XE-F4110-00	D - 11	5ND-F5383-10	D - 15	4XE-G6118-20	D - 6
1P0-E7241-00	C - 6	5XG-E8513-00	C - 12	1P0-F1649-00	D - 2	4XE-F414H-00	D - 11	5FU-F5384-00	E - 2	4XE-G6118-21	D - 6
5XG-E7285-00	C - 7	5XG-E8514-00	C - 8	1P0-F1651-00	D - 2	4XE-F415A-00	F - 3	4XE-F5390-50	D - 15	4XE-G6118-A3	D - 6
5XG-E7401-00	C - 6	5XG-E8531-00	C - 12	1P0-F1651-10	D - 2	F - 4	F - 4	5VH-F539F-00	D - 15	4XE-G6118-A4	D - 6
5XG-E7402-00	C - 6	5XG-E8534-00	C - 8	1P0-F1651-30	D - 2	1P0-F1651-30	F - 6	5VH-F5818-00	D - 15	4XE-G6118-A5	D - 6
4XE-E7537-15	D - 5	5XG-E8535-00	C - 12	1P0-F1651-50	D - 2	4XE-F415A-10	F - 4	4XE-F582T-10	D - 14	4XE-G6151-01	D - 5
4XE-E7537-30	D - 5	1P0-F1110-01	C - 14	4XE-F1696-00	F - 3	4XE-F415A-20	F - 5	5VH-F5833-00	D - 15	4XE-G6152-01	D - 5
4XE-E7537-40	D - 5	5FU-F111A-00	C - 14		F - 4	4XE-F415E-10	F - 5	4XE-F5871-00	E - 4	4XE-G6172-00	D - 6
4XE-E7537-45	D - 5	4XE-F1315-00	C - 14		F - 6	4XE-F416E-00	F - 4	4XE-F5872-00	E - 4	4XE-G6513-00	E - 2
4XE-E7537-50	D - 6	4XE-F1399-00	E - 6	4XE-F1696-10	F - 4	4XE-F4181-00	D - 11	4XE-F5873-00	E - 4	1P0-G6540-00	D - 4
4XE-E7537-60	D - 6	1P0-F1453-00	C - 14	4XE-F1696-20	F - 5	1P0-F4285-00	D - 2	4XE-F5874-00	E - 4	1P0-H1410-00	E - 7
5XG-E7551-00	C - 8	1P0-F1500-00	C - 15	1P0-F171A-00	D - 3	5ND-F470F-01	D - 12	5VH-F5898-00	D - 15	1P0-H1450-00	E - 7
5XG-E7553-00	C - 7	1P0-F1500-10	C - 15	1P0-F171A-10	D - 3	5ND-F470F-21	D - 12	5FU-F6111-10	E - 3	5XG-H1800-00	E - 8
5XG-E7556-00	C - 8	1P0-F1500-20	C - 15	1P0-F171A-30	D - 3	5ND-F4710-03	D - 12	1P0-F6124-00	E - 3	3KW-H1801-00	E - 8
5XG-E7558-00	C - 6	1P0-F1500-30	C - 15	1P0-F171A-50	D - 3	5ND-F4710-22	D - 12	4XE-F612K-10	E - 4	3KW-H1828-00	E - 8
1P0-E7642-00	C - 8	1P0-F1500-40	C - 15	5UH-F173B-00	F - 3	4XE-F4747-00	D - 12	5FU-F6241-10	E - 3	5XG-H183G-00	E - 8
5XG-E7968-00	C - 7	1P0-F1500-50	C - 15		F - 4	5ND-F4776-00	D - 12	1P0-F6331-00	E - 3	4XE-H2100-20	E - 14
5XG-E7968-10	C - 7	1P0-F1500-60	C - 15		F - 5	4XE-F478V-00	D - 12	1P0-F7211-00	E - 5	1P0-H2112-00	E - 14
5XG-E7968-20	C - 7	4XE-F151E-01	F - 3		F - 6	1P0-F4841-00	E - 6	1P0-F741A-00	E - 5	1P0-H2115-00	E - 14
5XG-E7968-30	C - 8		F - 4	5FU-F175B-01	C - 15	1P0-F4841-10	E - 6	1P0-F7452-00	E - 5	1P0-H2116-00	E - 13
5XG-E7968-40	C - 8	4XE-F151E-11	F - 4	1P0-F1781-C0	F - 3	1P0-F4842-00	E - 6	1P0-F7453-00	E - 5	1P0-H2128-00	E - 14
5XG-E7968-50	C - 8	4XE-F151H-10	F - 4		F - 4	1P0-F4842-10	E - 6	1P0-F7462-00	E - 5	5XG-H2507-00	E - 13
5XG-E7968-60	C - 8	4XE-F151K-00	D - 4		F - 5	4XE-F4877-20	F - 5	1P0-F7463-00	E - 5	5FU-H4314-10	E - 9
5XG-E7968-70	C - 8	4XE-F151K-10	D - 4		F - 6		F - 6	5ND-F8100-00	C - 14	5FU-H4320-10	E - 9
5XG-E7968-80	C - 8	4XE-F1539-10	F - 3	1P0-F1782-C0	F - 3	4XE-F4877-30	F - 3	4XE-F819R-10	F - 3	5FU-H4340-10	E - 9
5XG-E7968-90	C - 8		F - 4		F - 4		F - 4	5UH-F8309-01	C - 15	8CR-W0041-00	E - 4
5XG-E8103-00	C - 13		F - 5		F - 5	4XE-F4877-40	F - 4	5UH-F8349-00	C - 15	3GD-W0045-00	D - 14
5XG-E8116-00	C - 11		F - 6		F - 6	4XE-F4897-20	F - 5	1P0-F842M-00	E - 6	3GD-W0047-00	D - 14
5XG-E8117-00	C - 10	4XE-F1549-00	F - 3	4XE-F2110-20	D - 4		F - 6	1P0-F845N-00	E - 6	1UY-W0048-50	D - 14
5XG-E8118-00	C - 13		F - 4	4XE-F2141-00	D - 4	4XE-F4897-30	F - 3	1P0-F845N-10	E - 6	3GD-W0057-00	D - 14
5XG-E8120-00	C - 13		F - 5	4XE-F2143-00	D - 4		F - 4	4XE-G6101-01	D - 5	5XG-WE141-00	B - 5
5XG-E8126-00	C - 13		F - 6	4XE-F214H-00	D - 4	4XE-F4897-40	F - 4	4XE-G6102-00	D - 5	5VH-WF536-00	D - 15
5XG-E8127-00	C - 13	1P0-F155A-00	F - 5	4XE-F219X-00	D - 4	4XE-F5111-20	D - 13	4XE-G6117-25	D - 6	52G-Y1754-00	C - 7
5XG-E812A-00	C - 8	4XE-F1568-00	F - 3	4XE-F2210-10	D - 8	4XE-F514A-00	D - 14	4XE-G6117-30	D - 6	4XE-Y4612-00	D - 5
5XG-E8140-00	C - 13		F - 4	4XE-F3350-10	D - 9	4XE-F5180-50	D - 13	4XE-G6117-35	D - 6	90101-10303	B - 8
5XG-E8154-00	C - 10	4XE-F1568-10	F - 6	4XE-F3501-20	D - 9	5FU-F5319-00	E - 2	4XE-G6117-40	D - 6	90101-10568	B - 5
5XG-E8154-10	C - 10	4XE-F1568-20	F - 4	4XE-F3502-20	D - 9	5FU-F531E-10	E - 2	4XE-G6117-45	D - 6	90101-12882	D - 9
1P0-E8164-00	C - 10	4XE-F1568-50	F - 5	4XE-F3549-00	D - 9	5VH-F5321-10	D - 15	4XE-G6117-50	D - 6	90105-08195	B - 2
5XG-E8177-00	C - 13	4XE-F1578-00	F - 3	4XE-F3570-10	D - 9	5FU-F5327-00	E - 2	4XE-G6118-10	D - 6	90105-08805	C - 14
5XG-E817A-00	C - 13		F - 4	4XE-F3580-10	D - 9	5VH-F5333-00	D - 15	4XE-G6118-11	D - 6	90105-08806	C - 14
5XG-E8185-00	C - 12	4XE-F1578-10	F - 4	1P0-F3813-00	D - 10	5FU-F5336-00	E - 2	4XE-G6118-12	D - 6	90105-08888	C - 14
1P0-E8191-00	C - 10	1P0-F1585-00	C - 14	4XE-F3831-00	D - 10	5FU-F533A-10	D - 15	4XE-G6118-13	D - 6	90105-08892	E - 2

NUMERICAL INDEX

PART NO.	GRID NO.	PART NO.	GRID NO.	PART NO.	GRID NO.	PART NO.	GRID NO.	PART NO.	GRID NO.	PART NO.	GRID NO.
90105-088B2	D - 14	90185-10115	D - 10	90269-08813	D - 3	90467-10008	D - 11	92907-05200	F - 2	93210-72800	B - 4
90105-10801	B - 13	90185-10844	D - 9	90280-03017	B - 5	90467-14015	B - 2	92907-05600	E - 3	93210-85706	D - 6
90105-10890	D - 9	90185-12072	D - 8	90280-05048	B - 5	90467-15012	C - 10	92907-06100	E - 8	93210-92800	B - 2
90105-10893	D - 4	90201-05029	E - 5	90282-05013	B - 5	90467-16195	D - 2		E - 12	93211-058A2	B - 2
90105-12889	D - 8	90201-06008	C - 10	90336-28053	D - 10	90468-15020	E - 2	92907-06200	C - 10	93211-51749	D - 5
90109-063F1	E - 6	90201-06074	E - 10	90338-08226	E - 13	90480-01400	D - 11		E - 5	93306-00006	C - 5
90109-06576	E - 12		E - 11	90338-26136	C - 5	90480-18290	D - 11	92907-06600	B - 8	93306-004YX	D - 13
90109-06873	E - 13	90201-060L5	D - 11	90338-34264	D - 4	90501-04503	C - 4		E - 4	93306-006Y3	C - 7
90110-06817	B - 14	90201-067P3	C - 10	90340-14029	D - 5	90501-101A5	C - 8		E - 7	93306-008Y0	D - 15
90114-10804	D - 13	90201-08016	E - 13	90340-14046	D - 5	90501-10245	E - 5		E - 13	93306-078Y0	B - 15
		90201-08093	C - 13	90340-14107	C - 10	90501-10782	E - 3	92907-08600	C - 8		C - 7
90116-10840	D - 5	90201-087G0	B - 2	90381-15040	C - 14	90501-13800	C - 8		C - 13	93306-202X2	C - 6
90119-06060	C - 15	90201-088C3	B - 2	90387-066J1	D - 11	90501-16768	C - 13	92907-10100	B - 5	93306-202XM	D - 13
		90201-10118	E - 4	90387-07598	D - 11	90501-18576	B - 10	9290P-08600	D - 5	93306-203X0	B - 15
90119-06227	D - 2	90201-101J1	B - 13	90387-090R0	D - 10	90501-243J7	C - 5	93101-15101	C - 6	93306-204Y6	C - 6
90119-06831	D - 11		D - 4	90387-150R1	D - 13	90506-08227	C - 13	93101-17113	B - 15	93306-278Y0	D - 15
90123-08046	E - 12	90201-107F8	B - 5	90387-1711G	D - 4	90506-16482	D - 15	93101-35097	D - 15	93306-30427	B - 5
90149-04278	E - 3	90201-108C6	B - 8	90387-255H9	D - 5	90506-18224	E - 5	93101-38098	D - 5	93306-304YE	C - 7
90149-05299	C - 15	90201-108P8	D - 10	90387-284T0	E - 2	90508-26539	C - 13	93101-52116	D - 5	93306-305Y6	D - 5
		90201-12588	C - 13	90389-25800	B - 8	90508-29570	C - 13	93102-12803	C - 13	93306-30611	B - 5
90149-06011	D - 11	90201-125F7	C - 8	90401-10159	E - 4	91317-06018	B - 2	93102-14856	C - 9	93310-530J3	B - 5
90149-08152	C - 6	90201-12790	E - 13	90430-06014	B - 2	91317-06020	B - 9	93102-22216	D - 13	93311-21044	D - 7
90149-08268	D - 14	90201-127J6	D - 8	90430-10148	E - 13		B - 10	93102-25017	D - 4	93315-23607	C - 12
90150-05802	E - 9	90201-128C9	C - 4	90430-12186	B - 2		C - 10	93102-65386	D - 5	93316-013Y0	D - 5
90151-06013	C - 12	90201-144J2	C - 10	90445-07810	E - 2	91317-06025	B - 4	93103-28141	B - 15	93317-855Y9	D - 5
90153-06803	B - 2	90201-147P2	C - 10	90445-078C4	D - 7	91317-06035	B - 14	93104-09025	E - 3	93332-000Y3	D - 4
90159-05011	C - 5	90201-148R0	D - 13	90445-08809	D - 11	91317-06085	B - 14	93105-26026	D - 13	93399-99917	C - 8
90170-06128	B - 7	90201-15700	C - 6	90446-16001	C - 10	91317-06115	B - 10	93106-47040	D - 15	93410-20038	C - 6
90170-08261	C - 11	90201-15797	E - 5	90450-47001	B - 9	91317-08016	C - 4	93112-31011	D - 10	93410-22039	C - 6
90170-14839	B - 5	90201-168R1	E - 2	90450-56006	B - 9	91317-08045	B - 2	93210-07590	C - 13		D - 6
		90201-25290	C - 4	90460-58124	B - 9	9131P-06020	B - 13	93210-09165	B - 7	93410-26067	C - 6
90170-22371	C - 5	90201-266F6	C - 5	90460-85135	D - 4	91401-16012	C - 13		C - 9	93410-32826	D - 9
90171-12816	D - 9	90201-404M6	C - 5	90460-99228	D - 4	91401-20012	E - 5	93210-13361	B - 4	93420-28055	C - 5
		90202-05193	D - 11	90462-06016	E - 13	91401-20015	C - 10	93210-14805	C - 10	93440-10085	B - 2
90171-14817	D - 13	90209-17285	C - 6	90464-08834	E - 14	91401-20025	D - 10	93210-15414	C - 14	93440-20088	D - 7
90171-16001	E - 2	90209-18208	C - 6	90464-10833	E - 14	91401-25020	D - 9	93210-16800	B - 6	93450-17044	B - 5
90179-08148	E - 12	90209-23241	C - 6	90464-10842	E - 14		D - 10	93210-17718	D - 4	93501-04805	C - 8
90179-08893	C - 14	90215-06809	B - 3	90464-12830	E - 15		D - 15	93210-19841	B - 15	93603-12801	B - 10
90179-10540	D - 13	90215-14186	C - 5	90464-12836	E - 14	91401-30025	D - 8	93210-25711	E - 8	93604-10837	B - 8
		90215-14810	B - 5	90464-19815	E - 14		D - 13	93210-26606	E - 2	93604-16092	C - 12
90179-12248	C - 8	90215-22259	C - 5	90464-20835	E - 14	91401-30030	E - 2	93210-34800	B - 10	93604-20156	C - 12
90179-16651	C - 7	90240-06076	E - 5	90464-25800	E - 14	91401-40030	E - 5	93210-35895	B - 9	93608-30839	C - 13
90179-28465	C - 7	90240-12092	D - 8	90464-31827	E - 12	91812-16805	B - 14	93210-53800	C - 8	93612-16254	B - 2
90179-35625	D - 9	90249-12008	E - 3		E - 14		B - 15	93210-548A1	B - 10	93615-12088	C - 4
90179-55464	C - 7		E - 5	90464-40825	E - 14	91A20-07010	B - 12	93210-55669	E - 8	93700-06004	C - 14
90183-05008	E - 9	90269-05055	C - 10	90464-48837	E - 14	92902-04100	B - 12	93210-57897	B - 2	93900-00810	D - 15
90183-06053	C - 15	90269-06800	D - 3	90467-07029	D - 7	92907-04600	B - 12	93210-59531	D - 5	93900-00813	D - 13
90183-08800	C - 15	90269-06804	C - 15	90467-07093	E - 2	92907-05100	E - 12	93210-64297	C - 14	94107-10800	D - 13



NUMERICAL INDEX

PART NO.	GRID NO.	PART NO.	GRID NO.	PART NO.	GRID NO.	PART NO.	GRID NO.	PART NO.	GRID NO.	PART NO.	GRID NO.
94110-10800	D - 15	97707-60420	E - 13								
94580-41104	B - 8	9770P-60416	E - 14								
94700-00852	B - 3	98501-04014	B - 12								
95027-06012	B - 2	98507-03008	D - 11								
95027-06025	B - 8	98507-03540	E - 9								
9502P-06008	E - 13	98507-04006	B - 11								
95307-05600	F - 2	98507-04008	B - 12								
95307-05700	E - 3	98507-04014	B - 12								
95307-08700	C - 13	98507-05020	E - 3								
95317-06700	E - 5	98507-05030	E - 12								
95317-08600	C - 11	98507-06016	E - 7								
95606-06100	E - 4		E - 8								
95607-05100	E - 3	98507-06020	B - 2								
95607-06100	E - 12		C - 3								
9560L-06200	D - 15		E - 12								
9561P-12100	D - 9	98507-06025	B - 15								
95707-05300	E - 5	98507-06030	B - 14								
95707-06300	E - 10	98507-06040	B - 14								
	E - 11		B - 15								
95707-10500	D - 6	98507-06060	B - 14								
95707-12500	D - 4		B - 15								
95807-06020	E - 14	98507-06070	B - 15								
95807-06025	E - 4	98507-06075	B - 14								
95807-08012	D - 4	98507-06080	B - 15								
95817-06016	C - 9	98507-06085	B - 14								
	C - 10	98517-05012	E - 12								
9581P-06016	E - 5	98580-04010	B - 11								
9581P-08012	C - 14	98706-04012	E - 4								
	E - 6	98707-05016	B - 15								
9581P-08016	E - 5	98707-06018	C - 2								
	E - 6	98707-06030	B - 10								
9581P-08030	D - 10	98907-06014	B - 15								
9581P-10020	E - 5	99009-12400	C - 4								
9581P-10045	D - 5	99009-14400	C - 8								
9581P-12025	D - 4	99009-26400	B - 6								
95827-08020	C - 14	99530-10014	B - 14								
9582P-06012	C - 14	99530-14016	B - 2								
	D - 14		B - 4								
	E - 2										
97007-06012	B - 3										
97007-06016	E - 4										
97007-06020	E - 13										
97017-06020	C - 13										
	E - 5										
97027-06016	B - 8										
97027-08025	C - 8										
9702P-08025	D - 5										
9702P-08060	D - 10										