



PARTS CATALOGUE

YFM35RX (5YTS) U.S.A.

YFM35RX (5YTT) CANADA

YFM35RX (5YTU) EUROPE

YFM35RX (5YTS) OCEANIA

YFM350R (5YTS) JAPAN

YFM35RX/YFM350R
PARTS CATALOGUE
©2007 by Yamaha Motor Co., Ltd.
1st edition, May 2007
All rights reserved.
Any reprinting or unauthorized use
without the written permission of
Yamaha Motor Co., Ltd.
is expressly prohibited.

A3

FOREWORD

This Parts Catalogue is related to the parts for the model(s) on the cover page. When you are ordering replacement parts, please refer to this Parts Catalogue and quote both part numbers and part names correctly.

1. Modifications or additions which have been made after the issue of the Parts Catalogue will be announced in the Parts News.

It is advisable that you make the necessary corrections to the Parts Catalogue according to the Parts News.

2. Abbreviations

The following abbreviations are used in this Parts Catalogue.

“UR” Use specified parts number.

“UN” Use as many as needed.

“AP” Alternate Parts

“LM” Locally Made (Parts need to be ordered locally)

“F#” Frame No. (Applicable machine No.)

“O/S” Over Size

3. The number of components for assembly

- Parts, which are to be supplied in an assembly, are listed with a dot (.) in front of the part name as shown below.
- The numeral appearing to the right of each component part indicates the quantity of parts for each assembly unit.

PART NO.	DESCRIPTION	Q'TY	REMARKS
2F5-83310-60	FRONT FLASHER LIGHT ASSY	2	
115-83311-60	.BULB (6V-18W)	1	

4. Applicable colours of graphics are represented in the “REMARKS” as shown below.

PART NO.	DESCRIPTION	Q'TY	REMARKS
2N4-24110-00-X5	FUEL TANK COMP.	2	MXR
3J1-24240-10	.GRAPHIC, FUEL TANK	1	FOR MXR

5. Note that the illustrations for reference in finding parts numbers are not to be used for assembling. When assembling, please use the applicable service manual.

6. The asterisk (*) before a reference number indicates modified items after the first edition.

FOREWORD

7. Applicable Serial No.

Engine Serial No.

Frame Serial No.

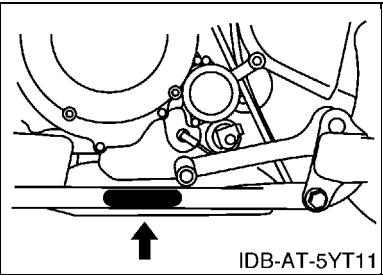
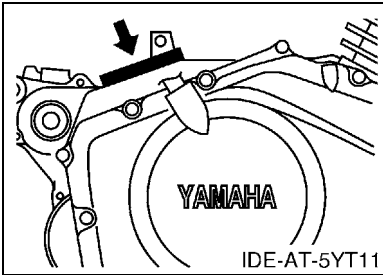

8. Applicable Colour Code (The (*) mark shows Model colour.)

Abbreviation	Colour Name	Colour Code
DPBSE(*)	DEEP PURPLISH BLUE SOLID E	0583
PGD(*)	PASTEL DARK GRAY	003E

9. Quantity Column Information

Column No.	Name Of Q'ty Column	Destination
1	USA	U.S.A.
2	CAN	CANADA
3	EUR	EUROPE
4	OCE	OCEANIA
5	JPN	JAPAN

CONTENTS

ENGINE

CYLINDER HEAD	B2
CYLINDER	B4
CRANKSHAFT & PISTON	B5
VALVE	B7
CAMSHAFT & CHAIN	B8
OIL PUMP	B9
INTAKE	B10
CARBURETOR	B11
EXHAUST	B13
CRANKCASE	B14
CRANKCASE COVER 1	B15
STARTER CLUTCH	C3
CLUTCH	C4
TRANSMISSION	C6
SHIFT CAM & FORK	C8

CHASSIS

FRAME	C10
FRONT FENDER	C12
REAR FENDER	C13
SIDE COVER	C15
REAR ARM	D2
REAR SUSPENSION	D4
STEERING	D5
FRONT SUSPENSION & WHEEL	D6
FUEL TANK	D8
SEAT	D9
FRONT WHEEL	D10
FRONT BRAKE CALIPER	D11
REAR WHEEL	D12
REAR BRAKE	D14
STEERING HANDLE & CABLE	D15
FRONT MASTER CYLINDER	E3
STAND & FOOTREST	E4
REAR MASTER CYLINDER	E5
GUARD	E7
GENERATOR	E8
STARTING MOTOR	E9
HEADLIGHT	E10
TAILLIGHT	E11
TAILLIGHT 2	E12

HANDLE SWITCH & LEVER	E13
ELECTRICAL 1	E14
ELECTRICAL 2	F2
EMBLEM & LABEL 1	F3
EMBLEM & LABEL 2	F4
EMBLEM & LABEL 3	F6
EMBLEM & LABEL 4	F7
EMBLEM & LABEL 5	F8

INDEX

NUMERICAL INDEX	M1
-----------------------	----

FIG. 1 CYLINDER HEAD

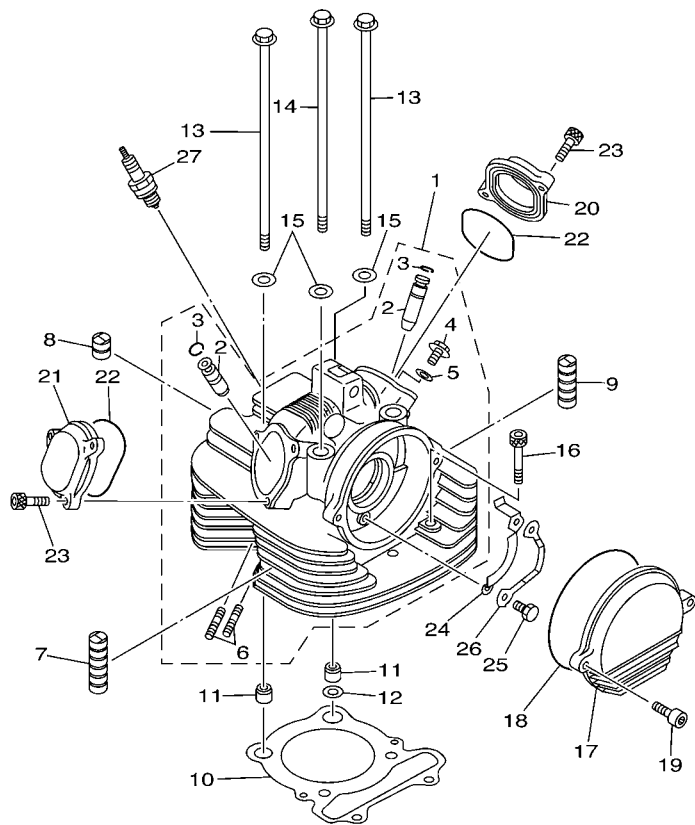

FWD
5YTG100-F010

REF. NO.	PART NO.	DESCRIPTION	USA	CAN	EUR	OCE	JPN	REMARKS
1	5YT-11101-10	CYLINDER HEAD ASSY	1	1	1	1	1	
2	3Y1-11133-11	.GUIDE, VALVE 1	2	2	2	2	2	
3	93440-12052	.CIRCLIP	2	2	2	2	2	
4	90401-06001	.BOLT, UNION	1	1	1	1	1	
5	90430-06192	.GASKET	1	1	1	1	1	
6	90116-06041	.BOLT, STUD	2	2	2	2	2	
7	3Y1-11127-00	ABSORBER 3	8	8	8	8	8	
8	31G-11161-00	ABSORBER 1	2	2	2	2	2	
9	31G-11127-00	ABSORBER 3	2	2	2	2	2	
10	1UY-11181-01	GASKET, CYLINDER HEAD 1	1	1	1	1	1	
11	99530-14016	PIN, DOWEL	2	2	2	2	2	
12	90430-14240	GASKET	1	1	1	1	1	
13	90105-10137	BOLT, FLANGE	2	2	2	2	2	
14	90105-10136	BOLT, FLANGE	2	2	2	2	2	
15	90201-10128	WASHER, PLATE	4	4	4	4	4	
16	91312-08050	BOLT	2	2	2	2	2	
17	5NF-11185-00	COVER, CYLINDER HEAD SIDE 1	1	1	1	1	1	
18	93211-06635	O-RING	1	1	1	1	1	
19	91312-06025	BOLT	2	2	2	2	2	
20	2NL-11186-12	COVER, CYLINDER HEAD SIDE 2	1	1	1	1	1	
21	2NL-11187-11	COVER, CYLINDER HEAD SIDE 3	1	1	1	1	1	
22	93210-57634	O-RING	2	2	2	2	2	
23	91312-06020	BOLT	5	5	5	5	5	
24	3Y1-1111F-00	PLATE	1	1	1	1	1	
25	97002-06012	BOLT	2	2	2	2	2	
26	90215-06162	WASHER, LOCK	1	1	1	1	1	
27	94701-00333	PLUG, SPARK (NGK DR8EA)	1	1	1	1	1	

FIG. 1 CYLINDER HEAD

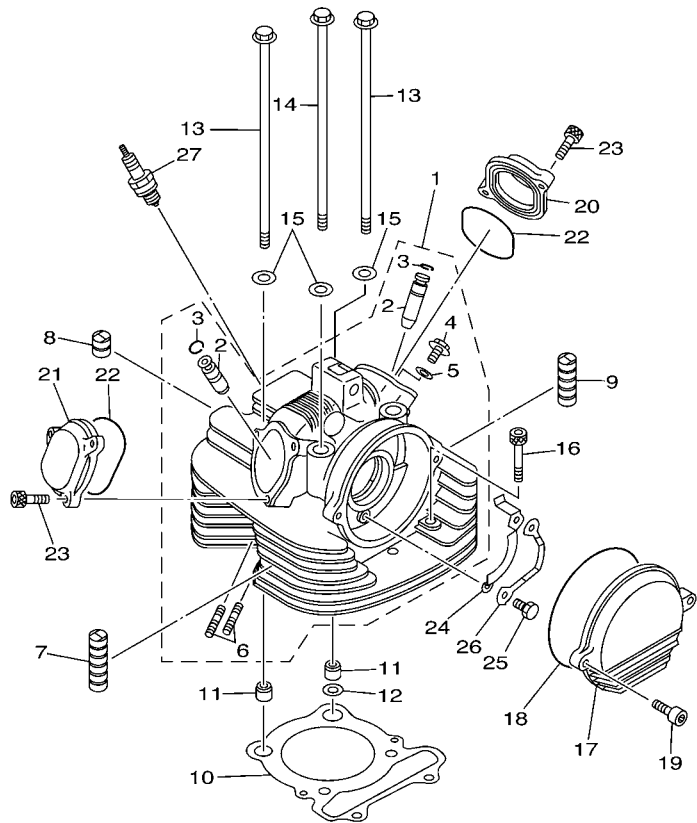

REF. NO.	PART NO.	DESCRIPTION	USA	CAN	EUR	OCE	JPN	REMARKS
27	94703-00333	PLUG, SPARK (NGK DR8EA)					1	

5YTG100-F010

FIG. 3 CRANKSHAFT & PISTON

REF. NO.	PART NO.	DESCRIPTION	USA	CAN	EUR	OCE	JPN	REMARKS
1	1UY-11400-00	CRANKSHAFT ASSY	1	1	1	1	1	
2	1UY-W1141-00	.CRANK SUB ASSY 1	1	1	1	1	1	
3	1UY-11422-00	.CRANK 2	1	1	1	1	1	
4	90240-07105	.PIN, CLEVIS	1	1	1	1	1	
5	90501-07629	.SPRING, COMPRESSION	1	1	1	1	1	
6	93602-13177	.PIN, DOWEL	1	1	1	1	1	
7	30X-11681-00	.PIN, CRANK 1	1	1	1	1	1	
8	93310-633T5	.BEARING	1	1	1	1	1	
9	1UY-11651-00	.ROD, CONNECTING	1	1	1	1	1	
10	90209-33253	.WASHER	2	2	2	2	2	
11	93306-30622	BEARING	1	1	1	1	1	
12	30X-11496-00	BOSS, BUFFER	1	1	1	1	1	
13	90501-22721	SPRING, COMPRESSION	6	6	6	6	6	
14	93605-10090	PIN, DOWEL	3	3	3	3	3	
15	3Y1-11531-02	GEAR, BALANCE WEIGHT	1	1	1	1	1	
16	30X-11565-00	WASHER, BEARING COVER	2	2	2	2	2	
17	90101-10017	BOLT	1	1	1	1	1	
18	92902-10100	WASHER, SPRING	1	1	1	1	1	
19	93210-16290	O-RING	1	1	1	1	1	
20	90201-10058	WASHER, PLATE	1	1	1	1	1	
21	90280-05048	KEY, WOODRUFF	1	1	1	1	1	
22	5UH-11631-00-C0	PISTON (STD)	1	1	1	1	1	
	5UH-11636-00	PISTON (0.50MM O/S)	1	1	1	1	1	AP
	5UH-11638-00	PISTON (1.00MM O/S)	1	1	1	1	1	AP
23	4GB-11610-00	PISTON RING SET (STD)	1	1	1	1	1	
	4GB-11610-20	PISTON RING SET (0.50MM O/S)	1	1	1	1	1	AP
	4GB-11610-40	PISTON RING SET (1.00MM O/S)	1	1	1	1	1	AP

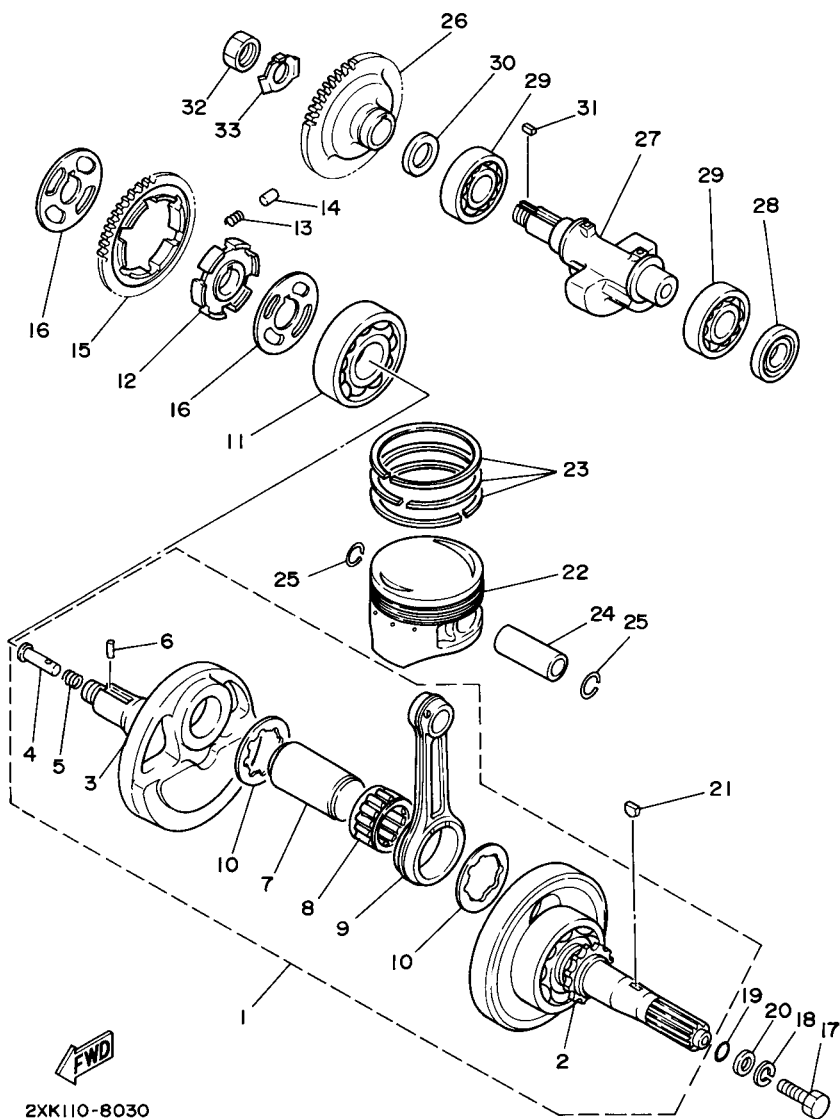
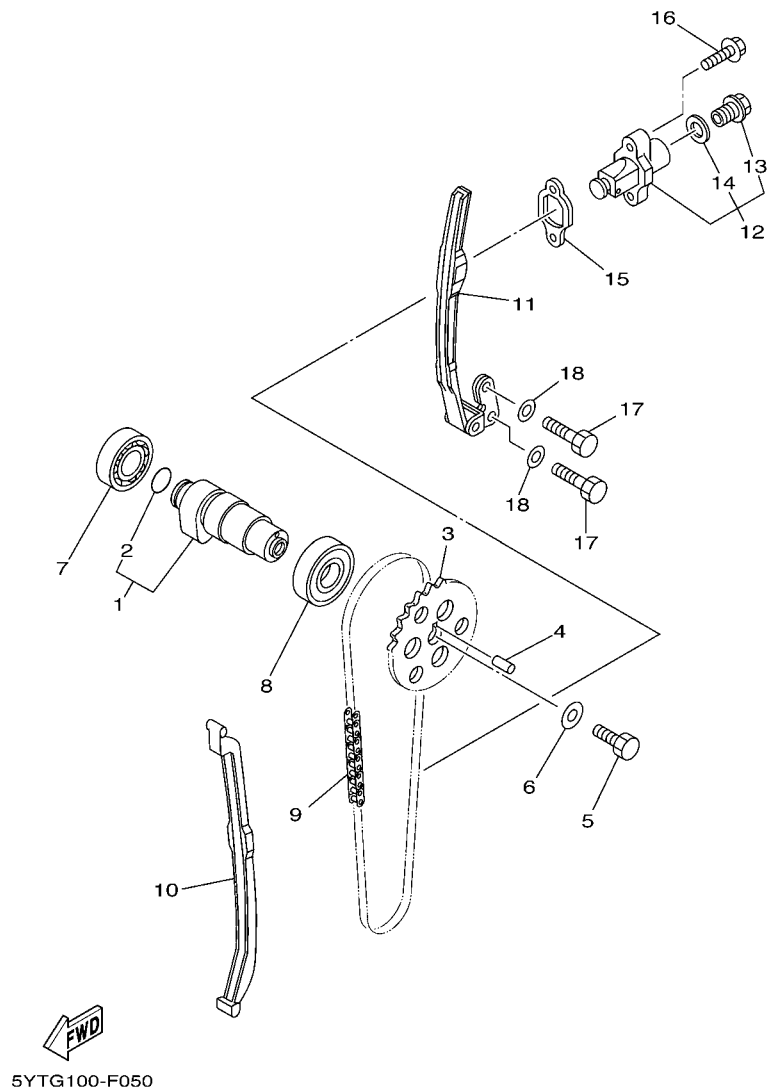

FIG. 5 CAMSHAFT & CHAIN



REF. NO.	PART NO.	DESCRIPTION	USA	CAN	EUR	OCE	JPN	REMARKS
1	5UH-12170-10	CAMSHAFT ASSY 1	1	1	1	1	1	
2	93210-17003	.O-RING	1	1	1	1	1	
3	5YT-12176-00	SPROCKET, CAM CHAIN	1	1	1	1	1	
4	93604-10011	PIN, DOWEL	1	1	1	1	1	
5	90101-10016	BOLT	1	1	1	1	1	
6	90201-10591	WASHER, PLATE	1	1	1	1	1	
7	93306-00438	BEARING	1	1	1	1	1	NIHONSEIKO
8	93306-00502	BEARING	1	1	1	1	1	
9	94500-02090	CHAIN (BF05M 90L)	1	1	1	1	1	
10	3Y1-12231-01	GUIDE, STOPPER 1	1	1	1	1	1	
11	1UY-12241-00	GUIDE, STOPPER 2	1	1	1	1	1	
12	31G-12210-01	TENSIONER ASSY, CAM CHAIN	1	1	1	1	1	
13	31G-12222-00	.PLUG	1	1	1	1	1	
14	31G-12214-00	.GASKET	1	1	1	1	1	
15	3GD-12213-00	GASKET, TENSIONER CASE	1	1	1	1	1	
16	95022-06025	BOLT, FLANGE	2	2	2	2	2	
17	97022-06016	BOLT	2	2	2	2	2	
18	92902-06600	WASHER, PLATE	2	2	2	2	2	

FIG. 6 OIL PUMP

REF. NO.	PART NO.	DESCRIPTION	USA	CAN	EUR	OCE	JPN	REMARKS
1	1UY-13300-00	OIL PUMP ASSY	1	1	1	1	1	
2	1UY-13326-00	.GEAR, PUMP DRIVEN 2	1	1	1	1	1	
3	93603-12030	.PIN, DOWEL	1	1	1	1	1	
4	93603-07073	.PIN, DOWEL	2	2	2	2	2	
5	90151-06010	.SCREW, COUNTERSUNK	1	1	1	1	1	
6	3GD-13329-00	GASKET, PUMP COVER	1	1	1	1	1	
7	98702-06030	SCREW, FLAT HEAD	3	3	3	3	3	
8	2XK-13416-00	PIPE, OIL 1	1	1	1	1	1	
9	51Y-13411-00	STRAINER, OIL	1	1	1	1	1	
10	90501-18576	SPRING, COMPRESSION	1	1	1	1	1	
11	30X-15351-00	PLUG, DRAIN	1	1	1	1	1	
12	93210-35520	O-RING	1	1	1	1	1	
13	1UY-13440-02	ELEMENT ASSY, OIL CLEANER	1	1	1	1	1	
14	3GD-13447-00	COVER, OIL ELEMENT	1	1	1	1	1	
15	93210-54175	O-RING	1	1	1	1	1	
16	91312-06020	BOLT	2	2	2	2	2	
17	90110-06189	BOLT, HEXAGON SOCKET HEAD	1	1	1	1	1	
18	1UY-13161-01	PIPE, DELIVERY 1	1	1	1	1	1	
19	90430-08119	GASKET	4	4	4	4	4	
20	90401-08004	BOLT, UNION	2	2	2	2	2	
21	1UY-13324-00	GEAR, PUMP DRIVE	1	1	1	1	1	
22	90280-05013	KEY, WOODRUFF	1	1	1	1	1	

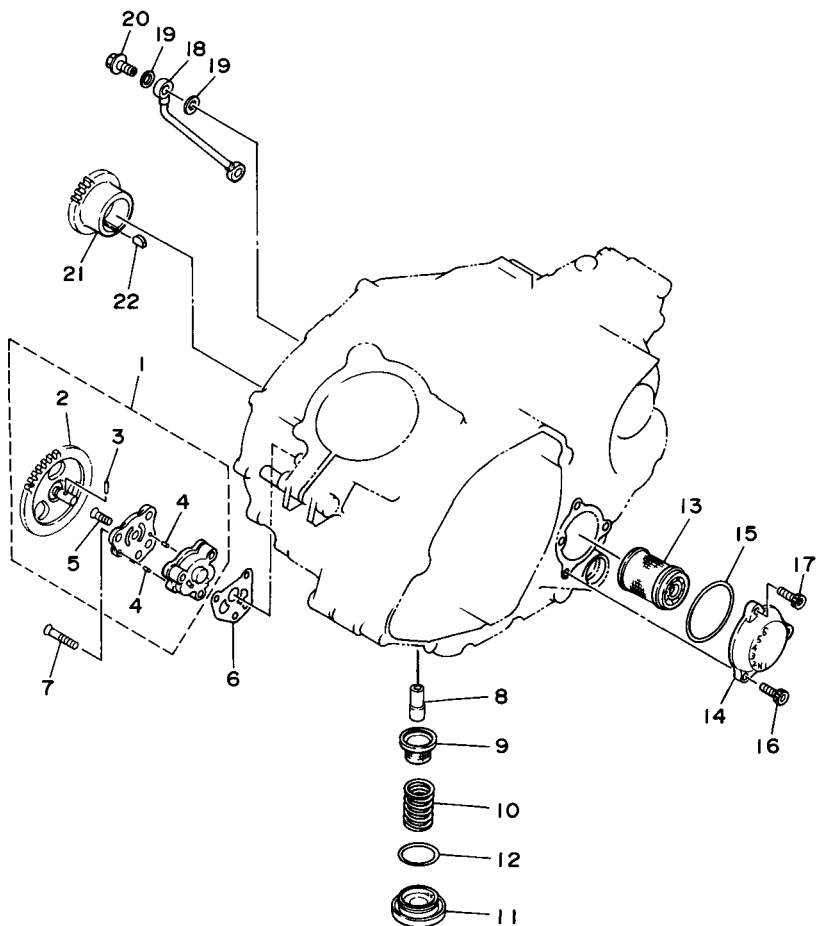

3GD1110-9060

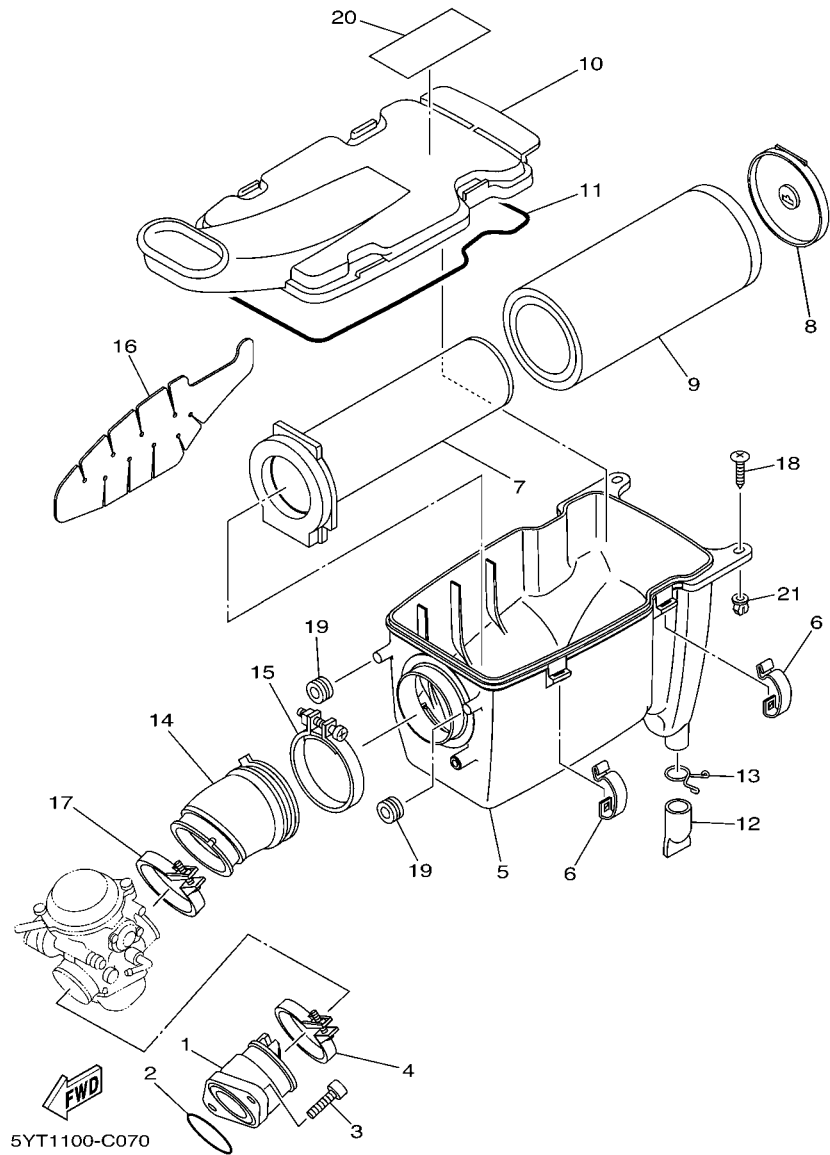

FIG. 7 INTAKE

REF. NO.	PART NO.	DESCRIPTION	USA	CAN	EUR	OCE	JPN	REMARKS
1	5YT-13586-00	JOINT, CARBURETOR 1	1	1	1	1	1	
2	93210-44545	O-RING	1	1	1	1	1	
3	91312-08025	BOLT	2	2	2	2	2	
4	90450-52003	HOSE CLAMP ASSY	1	1	1	1	1	
5	5YT-14411-00	CASE, AIR CLEANER 1	1	1	1	1	1	
6	5GH-14436-00	HOOK	4	4	4	4	4	
7	1UY-14458-01	GUIDE	1	1	1	1	1	
8	1UY-14468-00	PLATE,ELEMENT FITTING	1	1	1	1	1	
9	1UY-14451-00	ELEMENT, AIR CLEANER	1	1	1	1	1	
10	5YT-14412-01	CAP, CLEANER CASE 1	1	1	1	1	1	
11	4FU-14452-00	SEAL	1	1	1	1	1	
12	59V-14457-00	SEAL	1	1	1	1	1	
13	90467-220A1	CLIP	1	1	1	1	1	
14	5YT-14453-00	JOINT, AIR CLEANER 1	1	1	1	1	1	
15	90460-75020	CLAMP, HOSE	1	1	1	1	1	
16	5YT-1442F-00	PROTECTOR	1	1	1	1	1	
17	90450-63004	HOSE CLAMP ASSY	1	1	1	1	1	
18	97702-60025	SCREW, TAPPING	2	2	2	2	2	
19	90480-15005	GROMMET	2	2	2	2	2	
20	5UH-2177C-20	PLATE, EPA OFFROAD ATV 1	1					
21	90338-08226	PLUG	2	2	2	2	2	

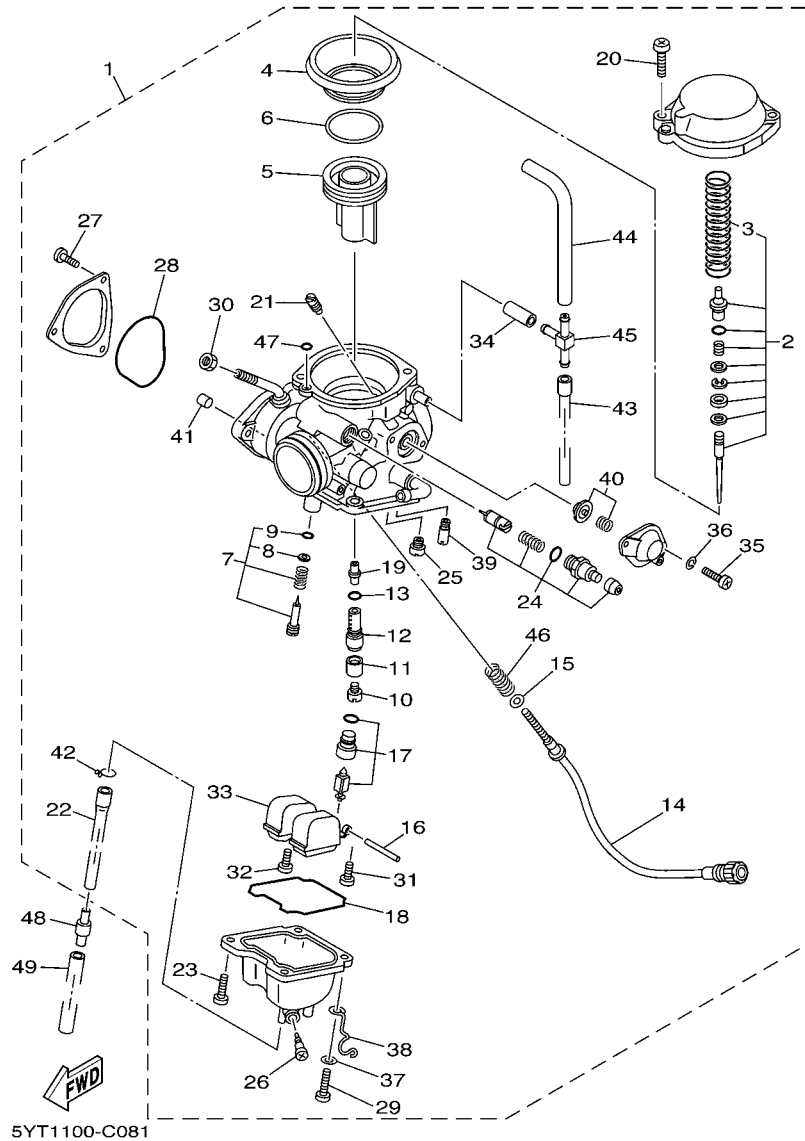

FIG. 8 CARBURETOR

REF. NO.	PART NO.	DESCRIPTION	USA	CAN	EUR	OCE	JPN	REMARKS
1	5YT-14901-10	CARBURETOR ASSY 1	1	1				
	5YT-14901-00	CARBURETOR ASSY 1			1	1	1	
2	5YT-1490J-10	.NEEDLE SET	1	1				
	5YT-1490J-00	.NEEDLE SET			1	1	1	
3	5YT-24423-00	..SPRING, DIAPHRAGM	1	1	1	1	1	
4	8FA-14940-00	.DIAPHRAGM ASSY	1	1	1	1	1	
5	5YT-14112-00	.VALVE, THROTTLE 1	1	1	1	1	1	
6	5YT-14194-00	.RING	1	1	1	1	1	
7	5MP-14105-00	.PILOT SCREW SET	1	1	1	1	1	
8	3H1-14962-00	..WASHER	1	1	1	1	1	
9	3H1-14147-00	..O-RING	1	1	1	1	1	
10	3G2-1423A-79	.JET, MAIN (#142.5)	1	1	1	1	1	
11	5GH-14918-00	.RING	1	1	1	1	1	
12	5YT-14261-00	.HOLDER	1	1	1	1	1	
13	583-14561-00	.O-RING	1	1	1	1	1	
14	5YT-14123-00	.SCREW, AIR ADJUSTING	1	1	1	1	1	
15	5FU-14962-00	.WASHER	1	1	1	1	1	
16	127-14186-00	.PIN, FLOAT	1	1	1	1	1	
17	5YT-14190-25	.NEEDLE VALVE ASSY	1	1	1	1	1	
18	5DM-14561-00	.O-RING	1	1	1	1	1	
19	5YT-14141-40	.NOZZLE, MAIN	1	1	1	1	1	
20	4KM-14216-00	.SCREW	2	2	2	2	2	
21	1HX-14231-33	.JET, MAIN (#165)	1	1	1	1	1	
22	5YT-14193-00	.PIPE	1	1	1	1	1	
23	98507-04010	.SCREW, PAN HEAD	3	3	3	3	3	
24	5YT-1410A-00	.STARTER SET	1	1	1	1	1	
25	3G2-14231-14	.JET,PILOT AIR(#70)	1	1	1	1	1	

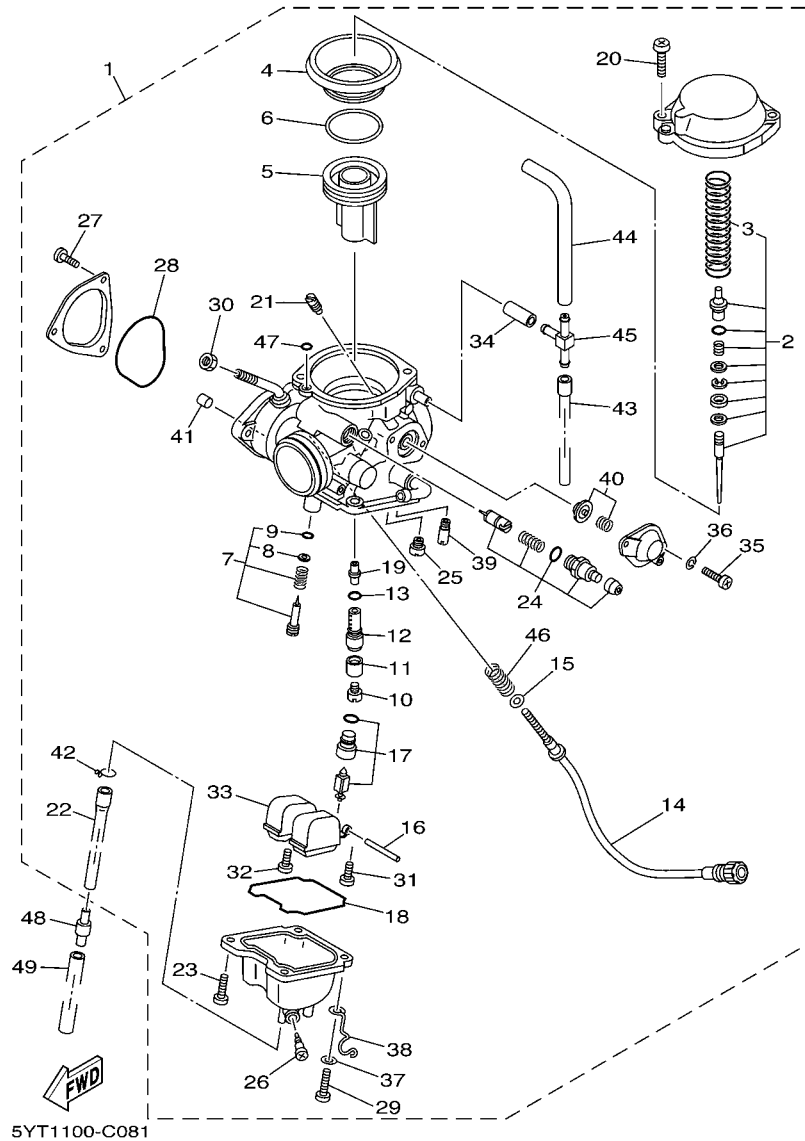

FIG. 8 CARBURETOR

REF. NO.	PART NO.	DESCRIPTION	USA	CAN	EUR	OCE	JPN	REMARKS
26	5LW-14191-00	.PLUG, DRAIN	1	1	1	1	1	
27	98507-04006	.SCREW, PAN HEAD	3	3	3	3	3	
28	5LP-14147-00	.O-RING	1	1	1	1	1	
29	98507-04012	.SCREW, PAN HEAD	1	1	1	1	1	
30	522-14161-00	.NUT, CABLE ADJUSTING	1	1	1	1	1	
31	98507-04008	.SCREW, PAN HEAD	1	1	1	1	1	
32	1FN-14565-00	.SCREW	1	1	1	1	1	
33	5DM-14985-00	.FLOAT	1	1	1	1	1	
34	5YT-14197-00	.PIPE	1	1	1	1	1	
35	98501-04014	.SCREW, PAN HEAD	2	2	2	2	2	
36	92902-04100	.WASHER, SPRING	2	2	2	2	2	
37	92907-04600	.WASHER	1	1	1	1	1	
38	5KM-14937-00	.CLIP	1	1	1	1	1	
39	4KM-14142-22	.JET, PILOT (# 22.5)	1	1	1	1	1	
40	5YT-1490H-00	.DIAPHRAGM SET 5	1	1	1	1	1	
41	3GD-14155-00	.GUIDE, CABLE	1	1	1	1	1	
42	80N-14139-00	.CLIP, PIPE	1	1	1	1	1	
43	5YT-14197-20	.PIPE	1	1	1	1	1	
44	5YT-14197-10	.PIPE	1	1	1	1	1	
45	28V-14988-00	.PIPE, STARTER CONNECTING	1	1	1	1	1	
46	137-14133-00	.SPRING, THROTTLE STOP	1	1	1	1	1	
47	354-14147-00	.O-RING	1	1	1	1	1	
48	24W-14193-00	PIPE	1	1	1	1	1	
49	91A20-07010	TUBE, FLEXIBLE VINYL	1	1	1	1	1	

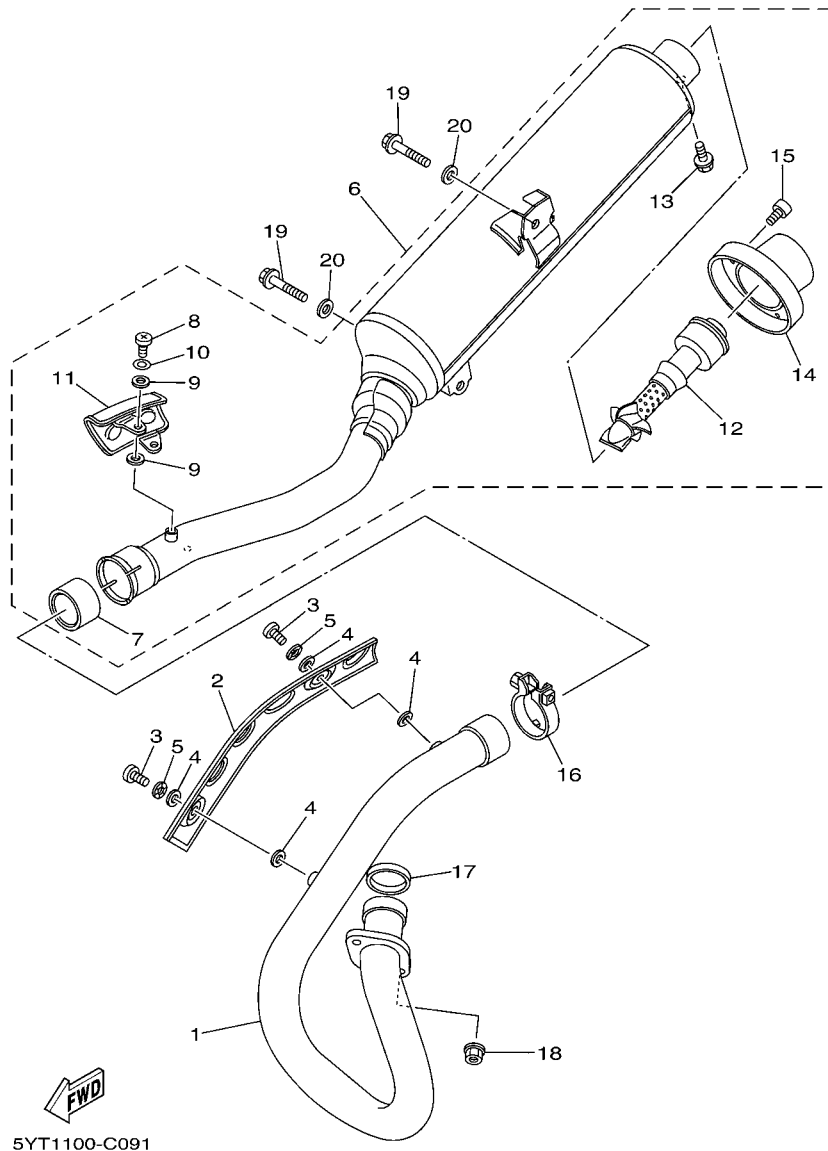
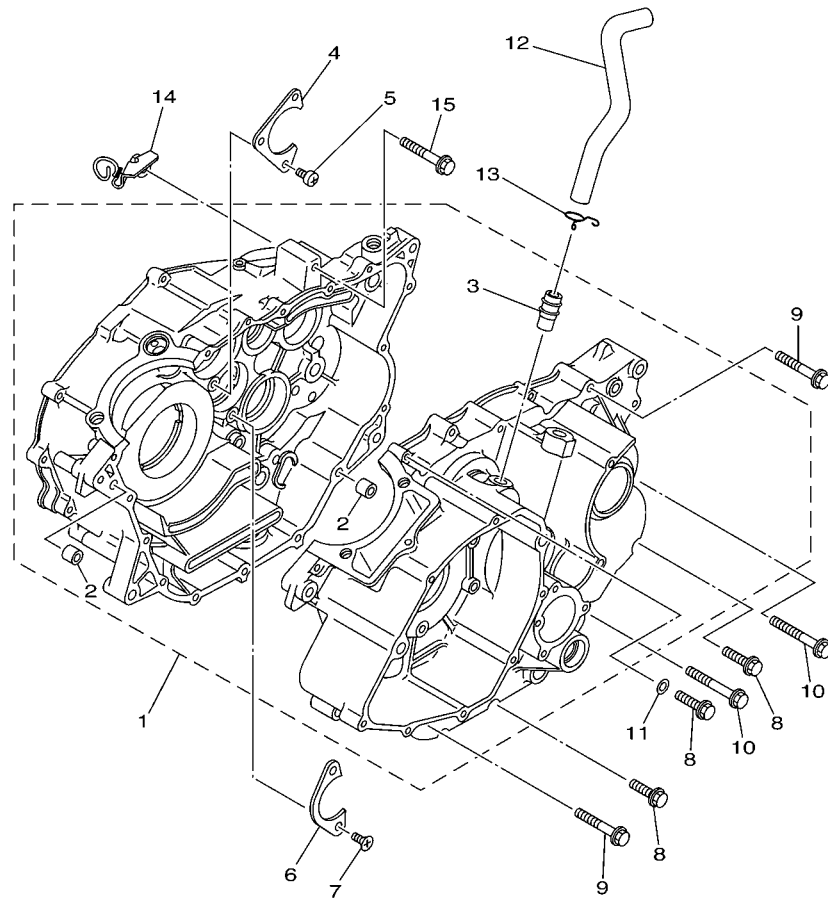

FIG. 9 EXHAUST

REF. NO.	PART NO.	DESCRIPTION	USA	CAN	EUR	OCE	JPN	REMARKS
1	1UY-14611-02	PIPE, EXHAUST 1	1	1	1	1	1	
2	5YT-14628-00	PROTECTOR, EXHAUST PIPE	1	1	1	1	1	
3	98902-06010	SCREW, BIND	2	2	2	2	2	
4	90201-05015	WASHER, PLATE	4	4	4	4	4	
5	92902-06200	WASHER	2	2	2	2	2	
6	5YT-14710-00	MUFFLER ASSY 1	1	1	1	1	1	
7	4WM-14755-00	.GASKET, SILENCER	1	1	1	1	1	
8	98902-06010	.SCREW, BIND	2	2	2	2	2	
9	90201-05015	.WASHER, PLATE	4	4	4	4	4	
10	92902-06200	.WASHER	2	2	2	2	2	
11	5YT-14708-01	.PROTECTOR ASSY	1	1	1	1	1	
12	5TG-14752-00	.PIPE, OUTLET	1	1	1	1	1	
13	95022-06008	.BOLT, FLANGE	1	1	1	1	1	
14	5YT-14787-00	.CAP, SILENCER	1	1	1	1	1	
15	90110-06134	.BOLT, HEXAGON SOCKET HEAD	3	3	3	3	3	
16	5YT-14788-00	BAND, SILENCER	1	1	1	1	1	
17	3GD-14613-00	GASKET, EXHAUST PIPE	1	1	1	1	1	
18	90179-06668	NUT	2	2	2	2	2	
19	95812-08016	BOLT, FLANGE	2	2	2	2	2	
20	90201-08048	WASHER, PLATE	2	2	2	2	2	



5YT1100-C100

FIG. 10 CRANKCASE

REF. NO.	PART NO.	DESCRIPTION	USA	CAN	EUR	OCE	JPN	REMARKS
1	3GD-15100-03	CRANKCASE ASSY	1	1	1	1	1	
2	99530-12016	.PIN, DOWEL	2	2	2	2	2	
3	371-11167-01	.PIPE, BREATHER 2	1	1	1	1	1	
4	3R4-15381-00	PLATE, BEARING COVER	1	1	1	1	1	
5	98502-06012	SCREW, PAN HEAD	3	3	3	3	3	
6	1UY-15383-00	PLATE, BEARING COVER	1	1	1	1	1	
7	98702-06016	SCREW, FLAT HEAD	2	2	2	2	2	
8	95022-06030	BOLT, FLANGE	8	8	8	8	8	
9	95022-06050	BOLT, FLANGE	6	6	6	6	6	
10	95022-06060	BOLT, FLANGE	2	2	2	2	2	
11	90430-06014	GASKET	1	1	1	1	1	
12	5YT-11166-00	PIPE, BREATHER 1	1	1	1	1	1	
13	90467-140A4	CLIP	1	1	1	1	1	
14	5YT-15441-10	HOLDER, CLUTCH CABLE	1	1	1	1	1	
15	95802-08045	BOLT, FLANGE	1	1	1	1	1	

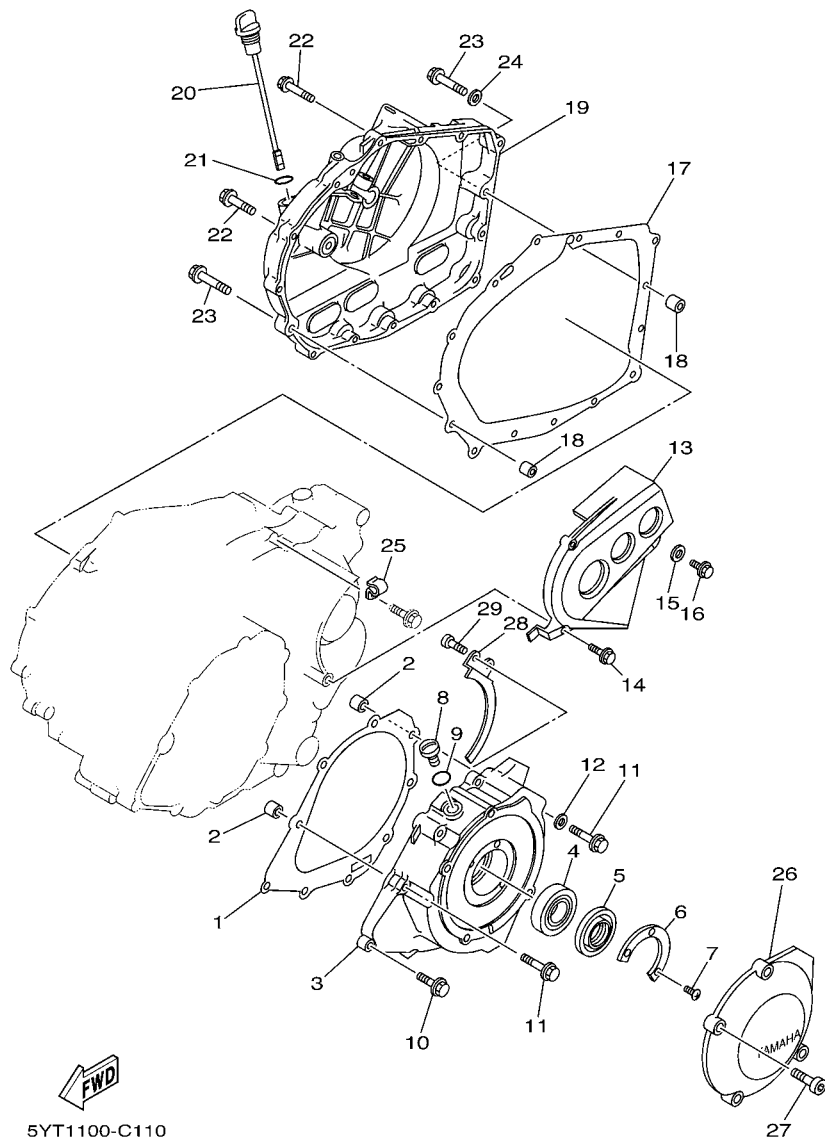

5YT1100-C110

FIG. 11 CRANKCASE COVER 1

REF. NO.	PART NO.	DESCRIPTION	USA	CAN	EUR	OCE	JPN	REMARKS
1	3GD-15451-00	GASKET, CRANKCASE COVER 1	1	1	1	1	1	
2	99530-12016	PIN, DOWEL	2	2	2	2	2	
3	3GD-15787-03	ADAPTOR	1	1	1	1	1	
4	93306-07801	BEARING	1	1	1	1	1	
5	93102-28476	OIL SEAL	1	1	1	1	1	
6	21V-15719-00	WASHER, THRUST	1	1	1	1	1	
7	90151-05023	SCREW, COUNTERSUNK	2	2	2	2	2	
8	90340-14117	PLUG, STRAIGHT SCREW	1	1	1	1	1	
9	93210-14369	O-RING	1	1	1	1	1	
10	95022-06025	BOLT, FLANGE	4	4	4	4	4	
11	95022-06045	BOLT, FLANGE	5	5	5	5	5	
12	90430-06014	GASKET	1	1	1	1	1	
13	1UY-15421-00	COVER, CRANKCASE 2	1	1	1	1	1	
14	95022-06020	BOLT, FLANGE	2	2	2	2	2	
15	90201-06085	WASHER, PLATE	1	1	1	1	1	
16	95022-06016	BOLT, FLANGE	1	1	1	1	1	
17	3GD-15461-00	GASKET, CRANKCASE COVER 2	1	1	1	1	1	
18	99530-12016	PIN, DOWEL	2	2	2	2	2	
19	3GD-15431-10	COVER, CRANKCASE 3	1	1	1	1	1	
20	1UY-15362-01	PLUG, OIL LEVEL	1	1	1	1	1	
21	93210-19522	O-RING	1	1	1	1	1	
22	95022-06030	BOLT, FLANGE	13	13	13	13	13	
23	95022-06040	BOLT, FLANGE	2	2	2	2	2	
24	90430-06014	GASKET	1	1	1	1	1	
25	90465-08045	CLAMP	1	1	1	1	1	
26	3GD-15411-00	COVER, CRANKCASE 1	1	1	1	1	1	
27	92012-06025	BOLT, BUTTON HEAD	4	4	4	4	4	

FIG. 11 CRANKCASE COVER 1

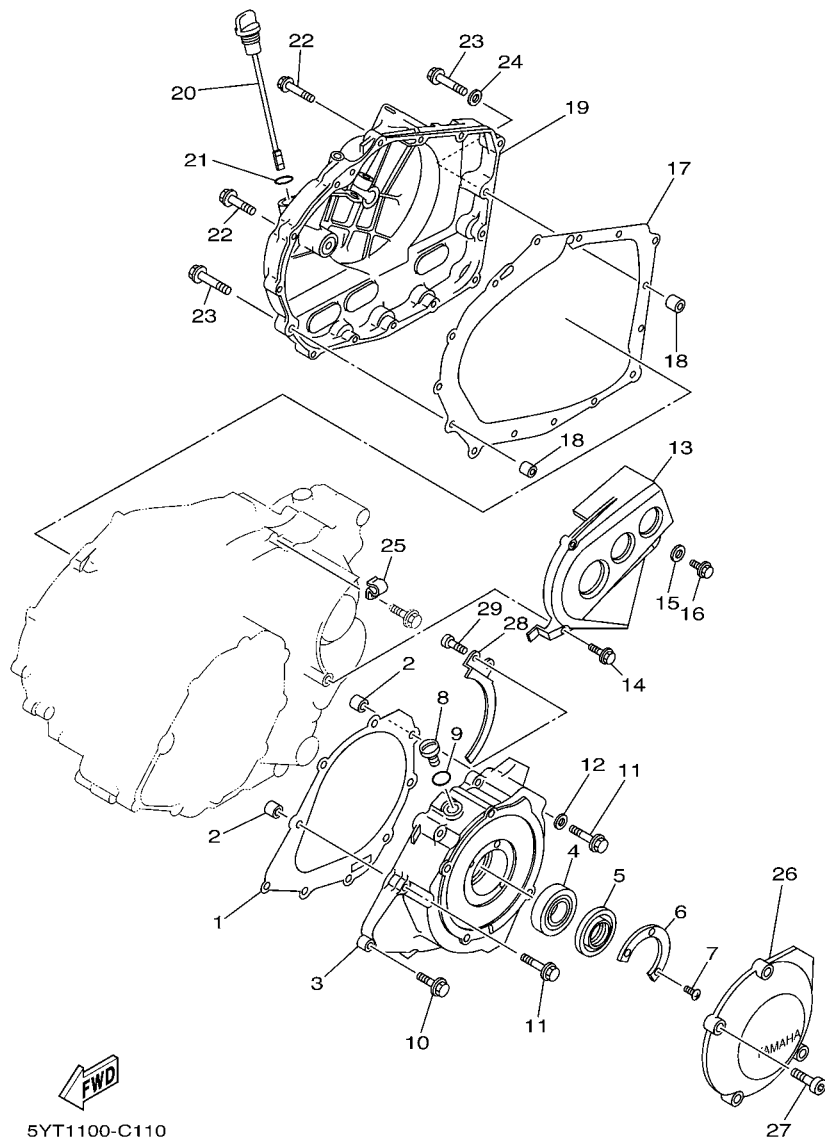

REF. NO.	PART NO.	DESCRIPTION	USA	CAN	EUR	OCE	JPN	REMARKS
28	1UY-81175-01	STOPPER 1	1	1	1	1	1	
29	98502-06012	SCREW, PAN HEAD	2	2	2	2	2	

FIG. 12 STARTER CLUTCH

REF. NO.	PART NO.	DESCRIPTION	USA	CAN	EUR	OCE	JPN	REMARKS
1	1UY-15512-00	GEAR, IDLER 1	1	1	1	1	1	
2	93310-212L6	BEARING	2	2	2	2	2	
3	1UY-15521-02	SHAFT 1	1	1	1	1	1	
4	90201-123K4	WASHER, PLATE	1	1	1	1	1	
5	99009-12400	CIRCLIP	1	1	1	1	1	
6	1UY-15517-01	GEAR, IDLER 2 (65T)	1	1	1	1	1	
7	90201-25291	WASHER, PLATE	1	1	1	1	1	
8	93310-225N0	BEARING	1	1	1	1	1	
9	1UY-15590-01	STARTER ONE-WAY ASSY	1	1	1	1	1	
10	90149-08016	SCREW	6	6	6	6	6	
11	3GD-15777-10	BOSS, STARTER PULLEY	1	1	1	1	1	

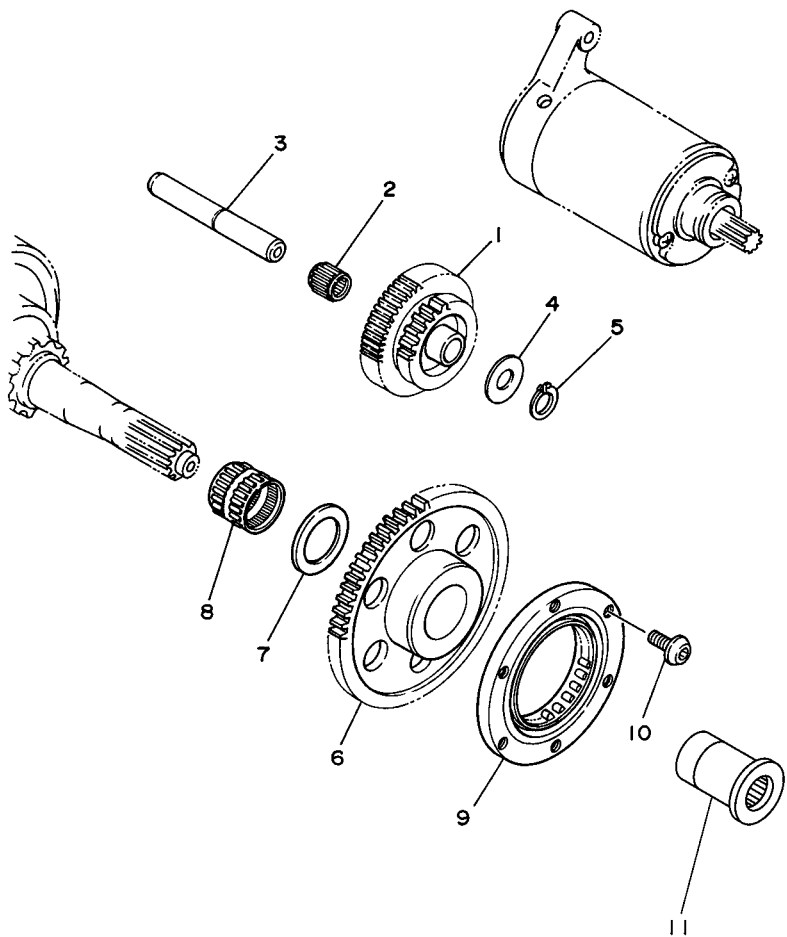

5YT1100-C120

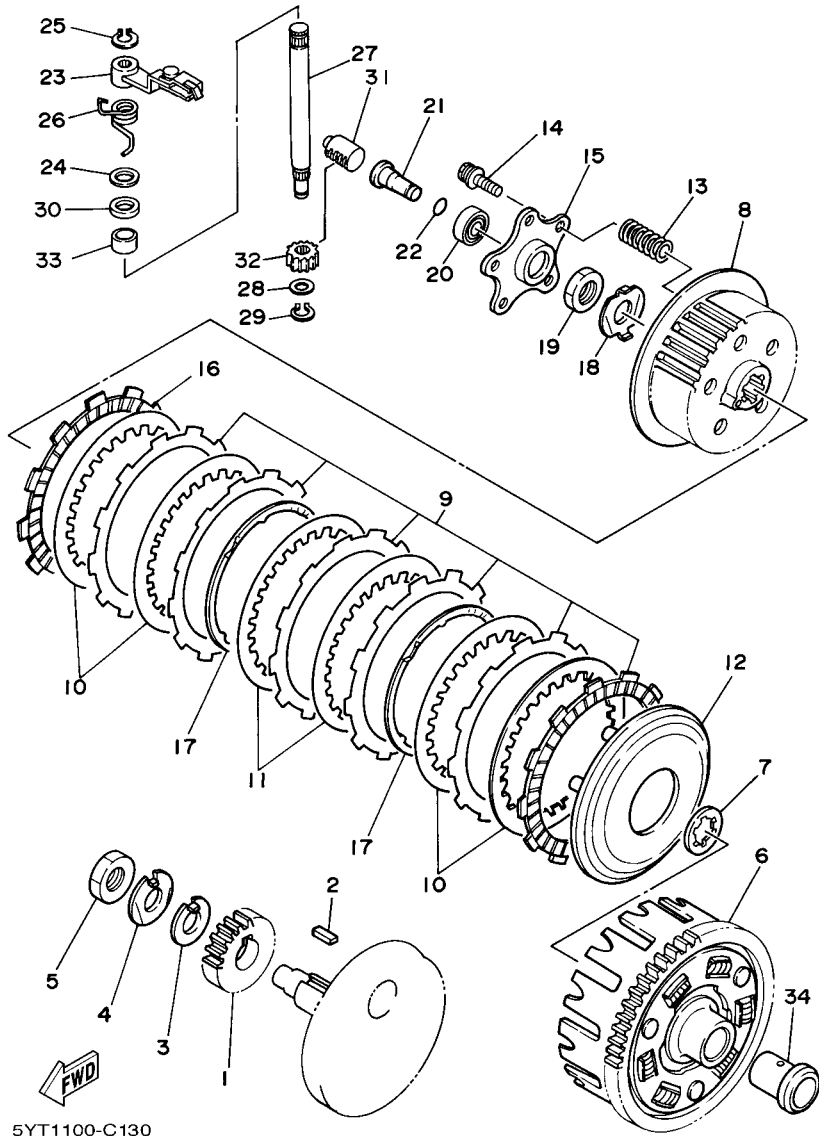
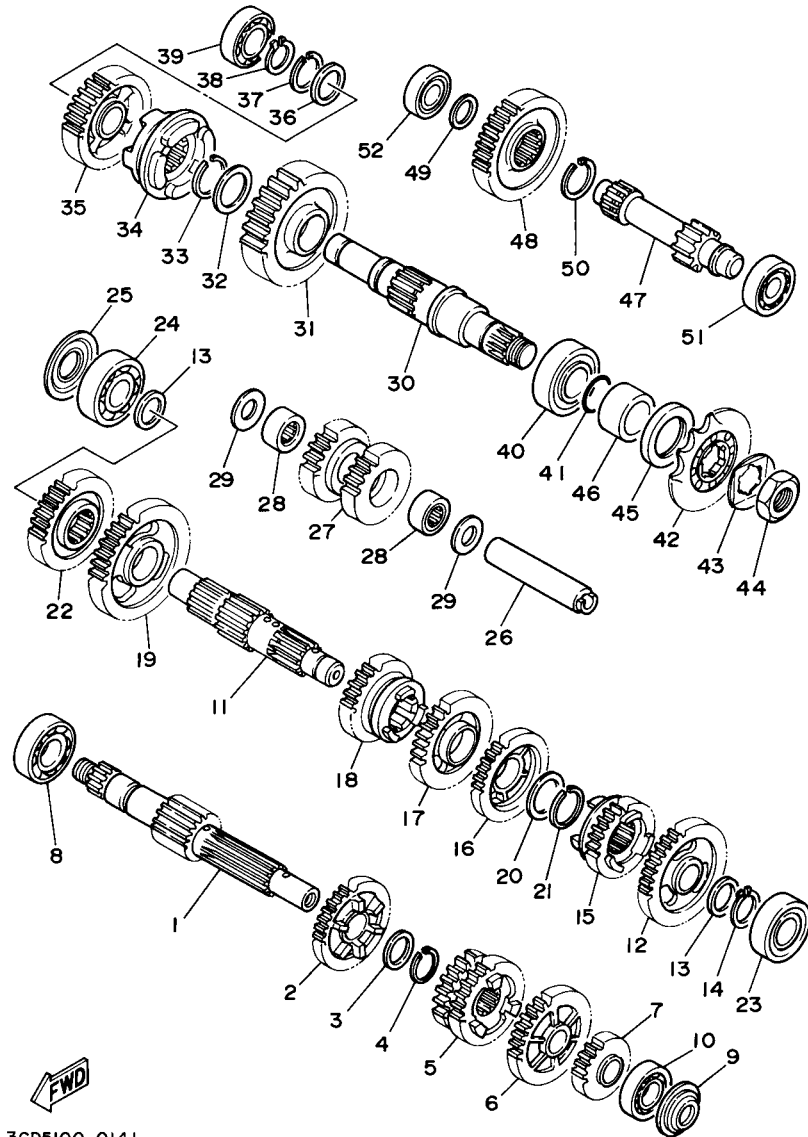

FIG. 13 CLUTCH

REF. NO.	PART NO.	DESCRIPTION	USA	CAN	EUR	OCE	JPN	REMARKS
1	1UY-16111-10	GEAR, PRIMARY DRIVE	1	1	1	1	1	
2	90282-07057	KEY, STRAIGHT	1	1	1	1	1	
3	90215-16156	WASHER, LOCK	1	1	1	1	1	
4	90215-16222	WASHER, LOCK	1	1	1	1	1	
5	90170-16343	NUT	1	1	1	1	1	
6	2NL-16150-00	PRIMARY DRIVEN GEAR COMP.(76T)	1	1	1	1	1	
7	30X-16154-00	PLATE, THRUST 1	1	1	1	1	1	
8	1UY-16371-02	BOSS, CLUTCH	1	1	1	1	1	
9	5Y1-16331-01	PLATE, FRICTION 2	6	6	6	6	6	
10	168-16325-00	PLATE, CLUTCH 2 (T=1.6)	4	4	4	4	4	
11	3J2-16324-00	PLATE, CLUTCH 1 (T=2.0)	2	2	2	2	2	
12	1UY-16351-00	PLATE, PRESSURE 1	1	1	1	1	1	
13	90501-231E9	SPRING, COMPRESSION	5	5	5	5	5	
14	90159-06029	SCREW, WITH WASHER	5	5	5	5	5	
15	1UY-16352-00	PLATE, PRESSURE 2	1	1	1	1	1	
16	31A-16321-01	PLATE, FRICTION	1	1	1	1	1	
17	5Y1-16383-00	SPRING, CLUTCH BOSS	2	2	2	2	2	
18	90215-16258	WASHER, LOCK	1	1	1	1	1	
19	90170-16326	NUT	1	1	1	1	1	
20	93306-00006	BEARING	1	1	1	1	1	
21	1UY-16358-00	PLATE, PUSH	1	1	1	1	1	
22	93210-06422	O-RING	1	1	1	1	1	
23	5YT-16340-00	PUSH LEVER ASSY	1	1	1	1	1	
24	90201-12163	WASHER, PLATE	1	1	1	1	1	
25	99001-09600	CIRCLIP	1	1	1	1	1	
26	90508-16022	SPRING, TORSION	1	1	1	1	1	
27	1UY-16382-00	AXLE, PUSH LEVER	1	1	1	1	1	

FIG. 14 TRANSMISSION



3GD5100-0141

REF. NO.	PART NO.	DESCRIPTION	USA	CAN	EUR	OCE	JPN	REMARKS
1	1UY-17401-01	MAIN AXLE ASSY	1	1	1	1	1	
2	1UY-17151-00	GEAR, 5TH PINION (28T)	1	1	1	1	1	
3	90209-18208	WASHER	1	1	1	1	1	
4	93410-22039	CIRCLIP	1	1	1	1	1	
5	1UY-17131-00	GEAR, 3RD PINION (23T/26T)	1	1	1	1	1	
6	1UY-17161-01	GEAR, 6TH PINION (29T)	1	1	1	1	1	
7	1UY-17121-00	GEAR, 2ND PINION (20T)	1	1	1	1	1	
8	93306-27202	BEARING	1	1	1	1	1	
9	93104-17094	OIL SEAL	1	1	1	1	1	
10	93306-20301	BEARING	1	1	1	1	1	
11	1UY-17421-02	AXLE, DRIVE	1	1	1	1	1	
12	5YT-17221-00	GEAR, 2ND WHEEL (33T)	1	1	1	1	1	
13	90201-203E7	WASHER, PLATE	2	2	2	2	2	
14	93410-20038	CIRCLIP	1	1	1	1	1	
15	5YT-17261-00	GEAR, 6TH WHEEL (23T)	1	1	1	1	1	
16	1UY-17241-00	GEAR, 4TH WHEEL (27T)	1	1	1	1	1	
17	1UY-17231-01	GEAR, 3RD WHEEL (29T)	1	1	1	1	1	
18	1UY-17251-00	GEAR, 5TH WHEEL (25T)	1	1	1	1	1	
19	1UY-17211-00	GEAR, 1ST WHEEL (36T)	1	1	1	1	1	
20	90201-256E6	WASHER, PLATE (T=0.9)	1	1	1	1	1	
21	93440-25084	CIRCLIP	1	1	1	1	1	
22	1UY-17123-00	GEAR, HIGH PINION (27T)	1	1	1	1	1	
23	93306-20401	BEARING	1	1	1	1	1	
24	93306-30424	BEARING	1	1	1	1	1	
25	93104-20068	OIL SEAL	1	1	1	1	1	
26	1UY-17432-01	AXLE, IDLE	1	1	1	1	1	
27	1UY-17223-02	GEAR, HIGH WHEEL (18T/20T)	1	1	1	1	1	

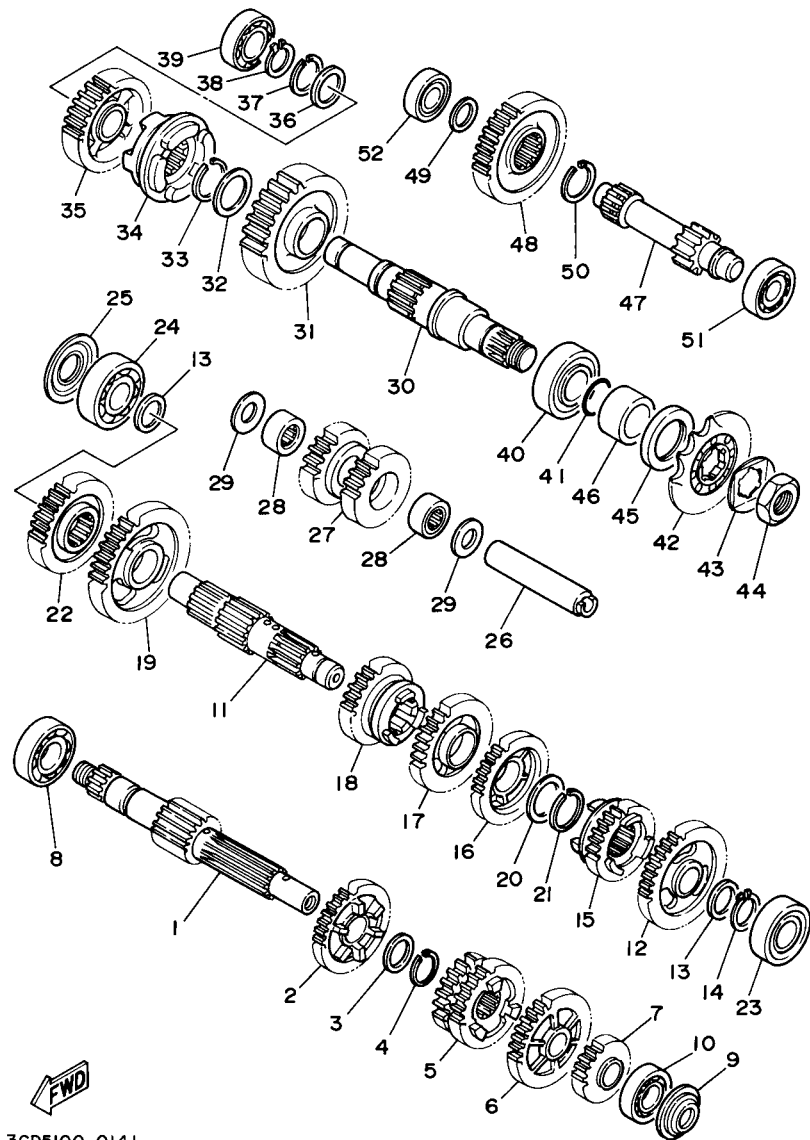

3GD5100-0141

FIG. 14 TRANSMISSION

REF. NO.	PART NO.	DESCRIPTION	USA	CAN	EUR	OCE	JPN	REMARKS
28	93311-41587	BEARING	2	2	2	2	2	
29	90201-150U6	WASHER, PLATE	2	2	2	2	2	
30	1UY-17523-00	SHAFT	1	1	1	1	1	
31	1UY-17253-00	GEAR, REVERSE WHEEL 2 (33T)	1	1	1	1	1	
32	90201-28665	WASHER, PLATE	1	1	1	1	1	
33	93440-28062	CIRCLIP	1	1	1	1	1	
34	1UY-17285-00	CLUTCH, DOG	1	1	1	1	1	
35	1UY-17582-00	GEAR, MIDDLE DRIVE (29T)	1	1	1	1	1	
36	90201-22793	WASHER, PLATE	1	1	1	1	1	
37	93410-22039	CIRCLIP	1	1	1	1	1	
38	93410-20038	CIRCLIP	1	1	1	1	1	
39	93306-00431	BEARING	1	1	1	1	1	
40	93306-20501	BEARING	1	1	1	1	1	
41	93210-22164	O-RING	1	1	1	1	1	
42	93834-13030	SPROCKET, DRIVE 13T(23X1746130)	1	1	1	1	1	
43	90215-21239	WASHER, LOCK	1	1	1	1	1	
44	90179-20255	NUT	1	1	1	1	1	
45	93102-35393	OIL SEAL	1	1	1	1	1	
46	90387-257N4	COLLAR	1	1	1	1	1	
47	1UY-17431-00	AXLE, COUNTER	1	1	1	1	1	
48	1UY-17243-00	GEAR, REVERSE WHEEL 1 (33T)	1	1	1	1	1	
49	90201-17255	WASHER, PLATE	1	1	1	1	1	
50	93440-25084	CIRCLIP	1	1	1	1	1	
51	93306-20301	BEARING	1	1	1	1	1	
52	93306-00308	BEARING	1	1	1	1	1	

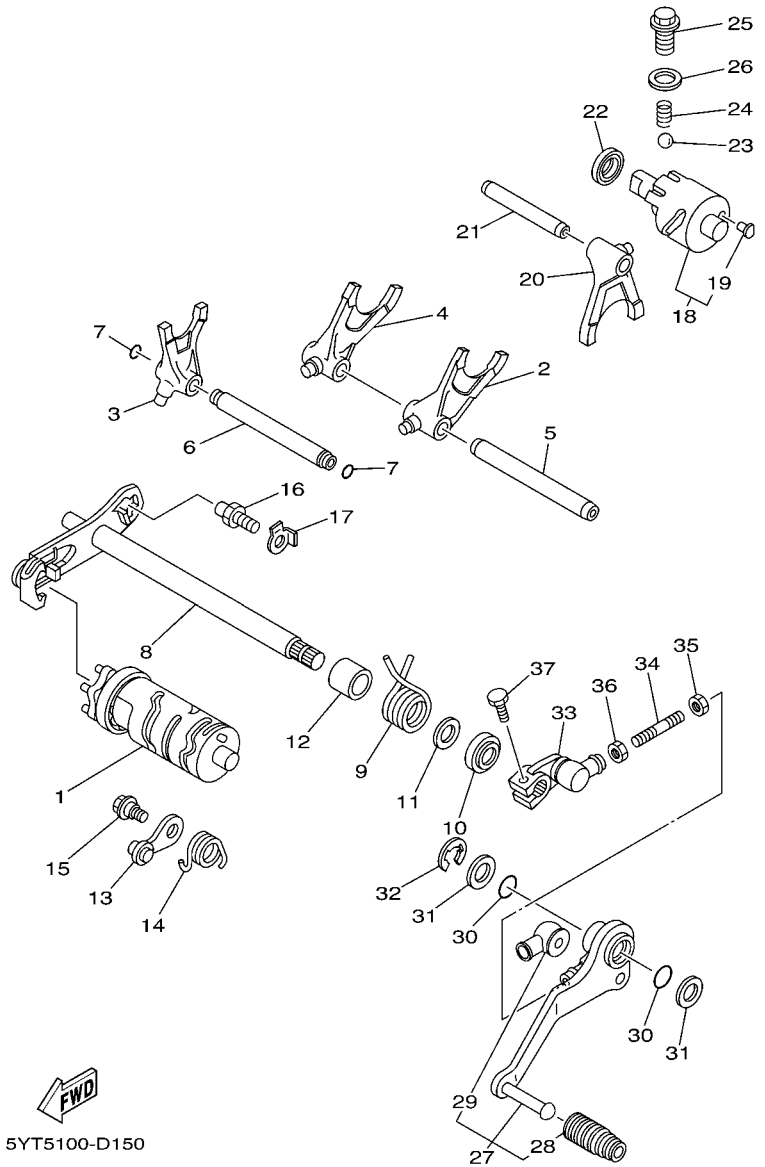
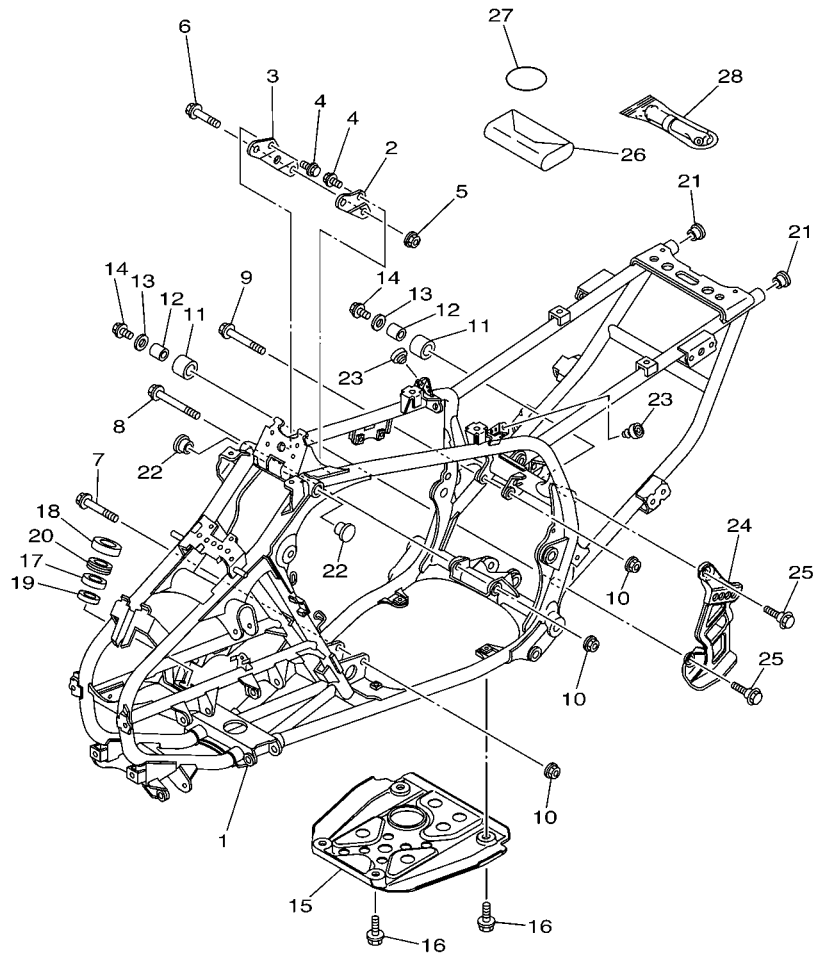

FIG. 15 SHIFT CAM & FORK

REF. NO.	PART NO.	DESCRIPTION	USA	CAN	EUR	OCE	JPN	REMARKS
1	5YT-18540-00	SHIFT CAM ASSY	1	1	1	1	1	
2	1YW-18511-00	FORK, SHIFT 1	1	1	1	1	1	
3	4GB-18512-00	FORK, SHIFT 2	1	1	1	1	1	
4	1UY-18513-00	FORK, SHIFT 3	1	1	1	1	1	
5	22U-18535-00	BAR, SHIFT FORK GUIDE 2	1	1	1	1	1	
6	4GB-18531-00	BAR, SHIFT FORK GUIDE 1	1	1	1	1	1	
7	93210-07590	O-RING	2	2	2	2	2	
8	1UY-18101-01	SHIFT SHAFT ASSY	1	1	1	1	1	
9	90508-32711	SPRING, TORSION	1	1	1	1	1	
10	93102-14209	OIL SEAL	1	1	1	1	1	
11	90201-14691	WASHER, PLATE	1	1	1	1	1	
12	90560-14284	SPACER	1	1	1	1	1	
13	1UY-18140-00	STOPPER LEVER ASSY	1	1	1	1	1	
14	90508-25712	SPRING, TORSION	1	1	1	1	1	
15	90109-06189	BOLT	1	1	1	1	1	
16	4G0-18127-00	STOPPER, SCREW	1	1	1	1	1	
17	90215-08260	WASHER, LOCK	1	1	1	1	1	
18	3GD-18420-00	SHIFTER ASSY	1	1	1	1	1	
19	3GH-18542-00	.POINT, NEUTRAL	1	1	1	1	1	
20	1UY-18311-00	FORK, SHIFT 1	1	1	1	1	1	
21	2A6-18531-00	BAR, SHIFT FORK GUIDE 1	1	1	1	1	1	
22	93102-15212	OIL SEAL	1	1	1	1	1	
23	93503-08007	BALL	1	1	1	1	1	
24	90501-10353	SPRING, COMPRESSION	1	1	1	1	1	
25	90105-14003	BOLT, FLANGE	1	1	1	1	1	
26	90430-14194	GASKET	1	1	1	1	1	
27	5YT-18110-10	SHIFT PEDAL ASSY	1	1	1	1	1	

FIG. 16 FRAME



5YT1100-C160

REF. NO.	PART NO.	DESCRIPTION	USA	CAN	EUR	OCE	JPN	REMARKS
1	5YT-21110-00	FRAME COMP.	1	1	1	1	1	UR FOR DPBSE
	5YT-21110-10	FRAME COMP.	1	1	1	1	1	UR FOR PGD
2	1UY-21315-20	STAY, ENGINE 2	1	1	1	1	1	
3	1UY-21316-20	STAY, ENGINE 3	1	1	1	1	1	
4	95812-08012	BOLT, FLANGE	4	4	4	4	4	
5	90185-08017	NUT, SELF-LOCKING	1	1	1	1	1	
6	95812-08055	BOLT, FLANGE	1	1	1	1	1	
7	90105-10211	BOLT, FLANGE	1	1	1	1	1	
8	90105-10277	BOLT, FLANGE	1	1	1	1	1	
9	90105-10185	BOLT, FLANGE	1	1	1	1	1	
10	90185-10011	NUT, SELF-LOCKING	3	3	3	3	3	
11	3TB-22178-00	TENSIONER	2	2	2	2	2	
12	4V4-22184-00	BUSH	2	2	2	2	2	
13	90201-08054	WASHER, PLATE	2	2	2	2	2	
14	95822-08012	BOLT, FLANGE	2	2	2	2	2	
15	5YT-21471-00	PROTECTOR, ENGINE	1	1	1	1	1	
16	90109-08100	BOLT	4	4	4	4	4	
17	93306-20331	BEARING	1	1	1	1	1	
18	93102-25081	OIL SEAL	1	1	1	1	1	
19	93102-25099	OIL SEAL	1	1	1	1	1	
20	2GU-23872-00	HOLDER, BEARING	1	1	1	1	1	
21	90338-18122	PLUG	2	2	2	2	2	
22	90338-23172	PLUG	2	2	2	2	2	
23	22W-24741-00	PAD, SEAT	2	2	2	2	2	
24	5YT-2117G-00	PROTECTOR	1	1	1	1	1	
25	90109-08100	BOLT	2	2	2	2	2	
26	2XK-28100-00	TOOL KIT	1	1	1	1	1	

C10

FIG. 16 FRAME

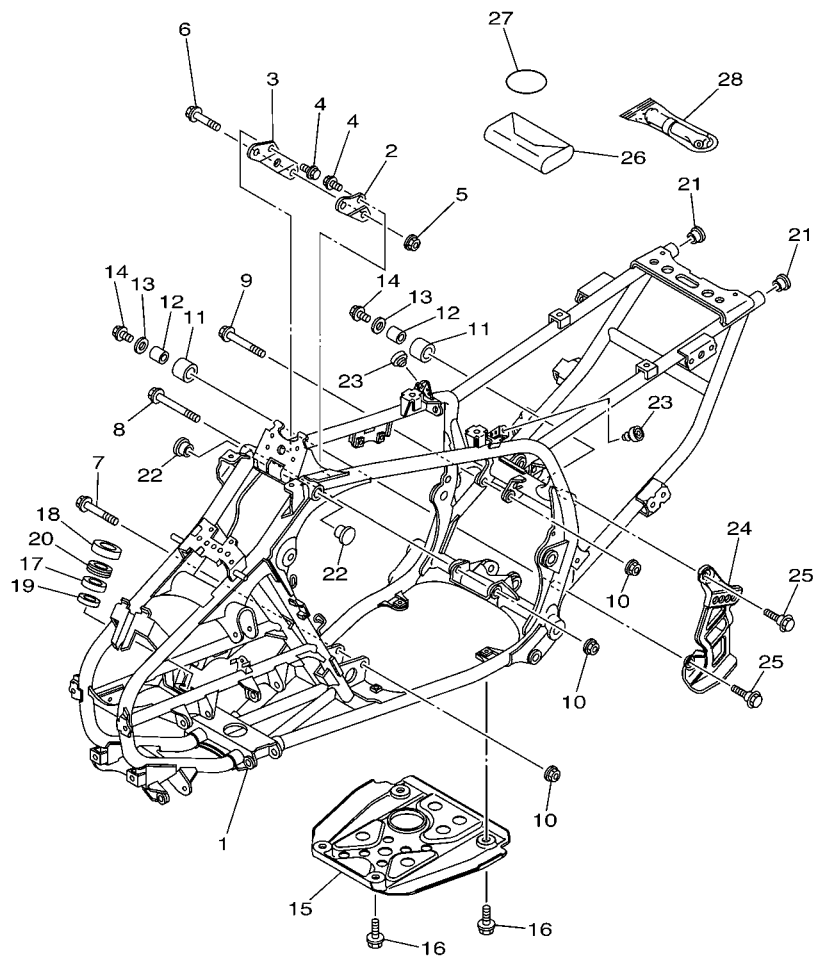

5YT1100-C160

REF. NO.	PART NO.	DESCRIPTION	USA	CAN	EUR	OCE	JPN	REMARKS
27	3TJ-82131-00	BAND, BATTERY	1	1	1	1	1	
28	1NV-2811A-01	GAUGE, AIR	1	1	1	1	1	

FIG. 17 FRONT FENDER

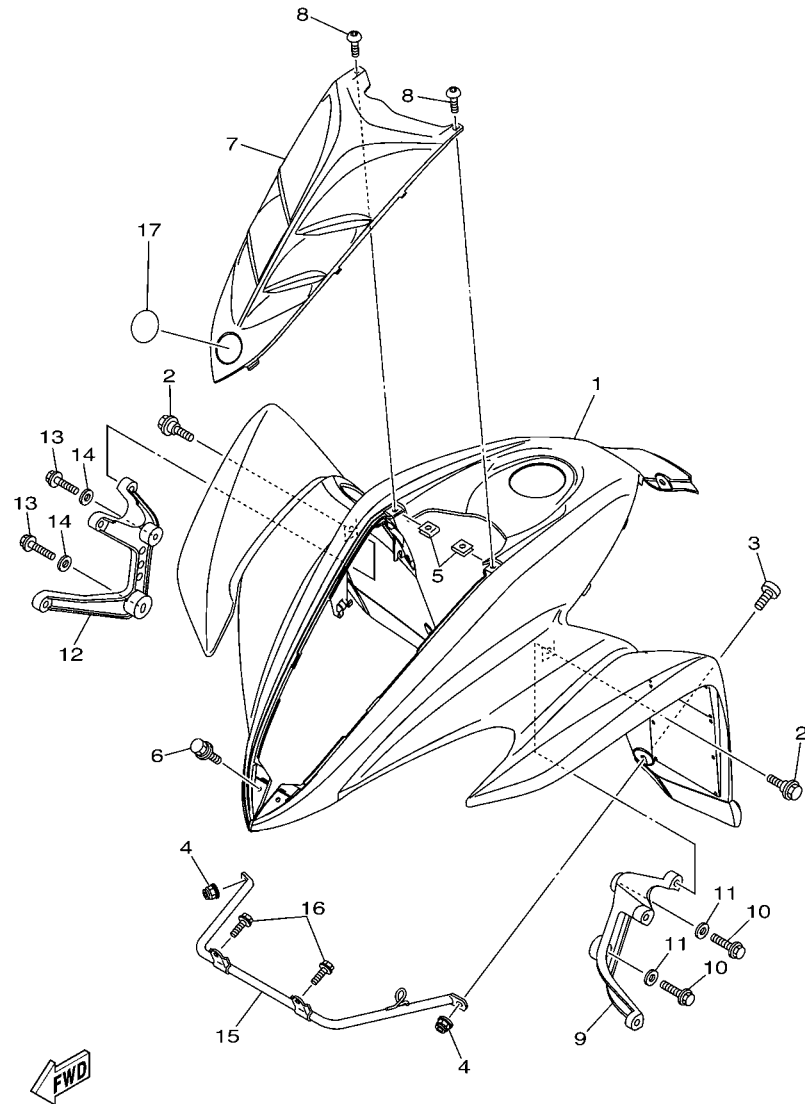

5YT1100-C170

REF. NO.	PART NO.	DESCRIPTION	USA	CAN	EUR	OC	JPN	REMARKS
1	5YT-W2151-01	FRONT FENDER COMP.	1					UR FOR DPBSE
	5YT-W2151-50	FRONT FENDER COMP.	1					UR FOR PGD
	5YT-W215C-01	FRONT FENDER COMP.2		1				UR FOR DPBSE
	5YT-W215C-50	FRONT FENDER COMP.2		1				UR FOR PGD
	5YT-W215B-00	FRONT FENDER COMP. 2			1			UR FOR DPBSE
	5YT-W215B-50	FRONT FENDER COMP. 2			1			UR FOR PGD
	5YT-W215E-00	FRONT FENDER COMP.				1		UR FOR DPBSE
	5YT-W215E-50	FRONT FENDER COMP.				1		UR FOR PGD
	5YT-W215D-00	FRONT FENDER COMP. 2					1	FOR DPBSE
2	90109-06172	BOLT	2	2	2	2	2	
3	90149-06306	SCREW	2	2	2	2	2	
4	95602-06200	NUT, SELF-LOCKING	2	2	2	2	2	
5	90183-05008	NUT, SPRING	2	2	2	2	2	
6	90119-06152	BOLT, WITH WASHER	2	2	2	2	2	
7	5YT-23391-40	PANEL, FRONT	1	1	1	1	1	UR FOR DPBSE
	5YT-23391-50	PANEL, FRONT	1	1	1	1	1	UR FOR PGD
8	90110-05201	BOLT, HEXAGON SOCKET HEAD	2	2	2	2	2	
9	5YT-21513-00	STAY, FENDER 1	1	1	1	1	1	
10	95812-06014	BOLT, FLANGE	2	2	2	2	2	
11	90201-06089	WASHER, PLATE	2	2	2	2	2	
12	5YT-21514-00	STAY, FENDER 2	1	1	1	1	1	
13	95812-06014	BOLT, FLANGE	2	2	2	2	2	
14	90201-06089	WASHER, PLATE	2	2	2	2	2	
15	5YT-21562-00	STAY, FENDER 3	1	1	1	1	1	
16	95822-06010	BOLT, FLANGE	2	2	2	2	2	
17	8AC-2414B-01	EMBLEM	1	1	1	1	1	

FIG. 18 REAR FENDER

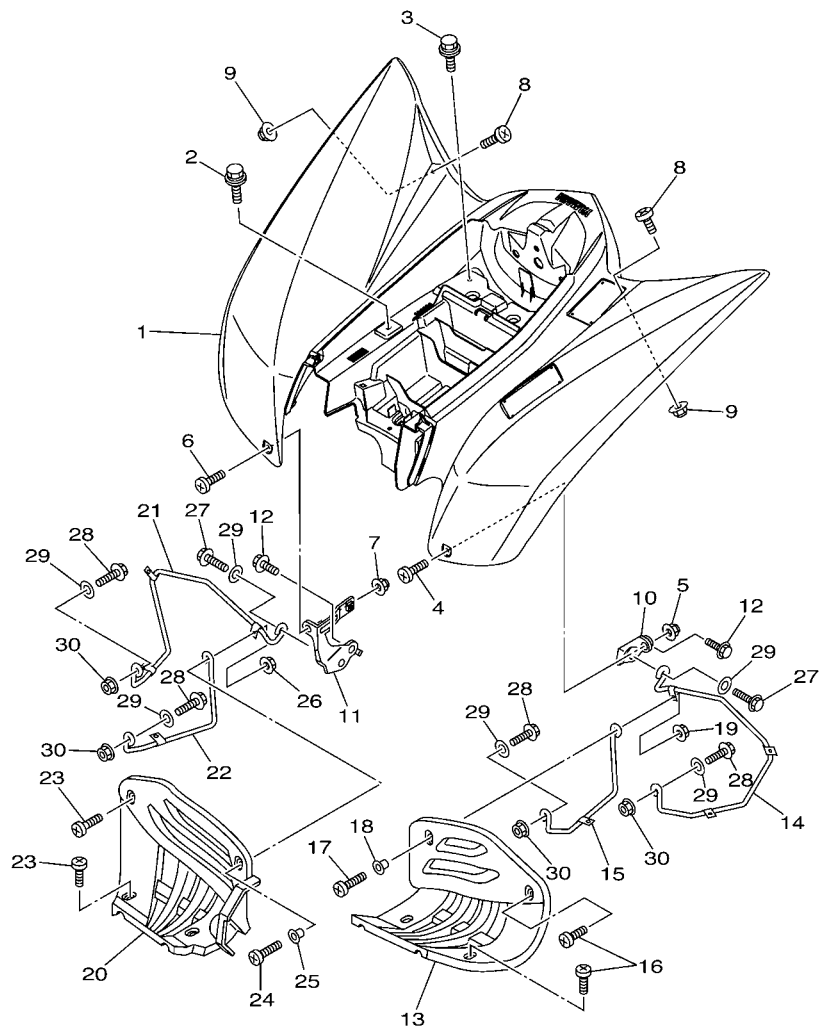

5YT1100-C180

REF. NO.	PART NO.	DESCRIPTION	USA	CAN	EUR	OCE	JPN	REMARKS	
1	5YT-W2161-00	REAR FENDER COMP.	1				1	1	UR FOR DPBSE
	5YT-W2161-50	REAR FENDER COMP.	1				1		UR FOR PGD
	5YT-W216C-00	REAR FENDER COMP.2		1					UR FOR DPBSE
	5YT-W216C-50	REAR FENDER COMP.2		1					UR FOR PGD
	5YT-W216B-00	REAR FENDER COMP.2				1			UR FOR DPBSE
	5YT-W216B-50	REAR FENDER COMP.2				1			UR FOR PGD
2	90119-06152	BOLT, WITH WASHER	2	2	2	2	2	2	
3	90119-06152	BOLT, WITH WASHER	2	2	2	2	2	2	
4	90149-06306	SCREW	1	1	1	1	1	1	
5	95602-06200	NUT, SELF-LOCKING	1	1	1	1	1	1	
6	90149-06306	SCREW	1	1	1	1	1	1	
7	95602-06200	NUT, SELF-LOCKING	1	1	1	1	1	1	
8	90149-06306	SCREW	2	2	2	2	2	2	
9	95602-06200	NUT, SELF-LOCKING	2	2	2	2	2	2	
10	5YT-21613-10	STAY, FENDER 1	1	1	1	1	1	1	
11	5YT-21614-10	STAY, FENDER 2	1	1	1	1	1	1	
12	95822-08012	BOLT, FLANGE	2	2	2	2	2	2	
13	5LP-21621-00	FLAP	1	1	1	1	1	1	
14	5YT-2164F-10	STAY 1	1	1	1	1	1	1	
15	5YT-2164H-10	STAY 3	1	1	1	1	1	1	
16	90154-05013	SCREW, BINDING	3	3	3	3	3	3	
17	90154-06061	SCREW, BINDING	1	1	1	1	1	1	
18	90387-062E0	COLLAR	1	1	1	1	1	1	
19	95602-06200	NUT, SELF-LOCKING	1	1	1	1	1	1	
20	5LP-21691-00	FLAP	1	1	1	1	1	1	
21	5YT-2164G-10	STAY 2	1	1	1	1	1	1	
22	5YT-2164J-10	STAY 4	1	1	1	1	1	1	

FIG. 20 REAR ARM

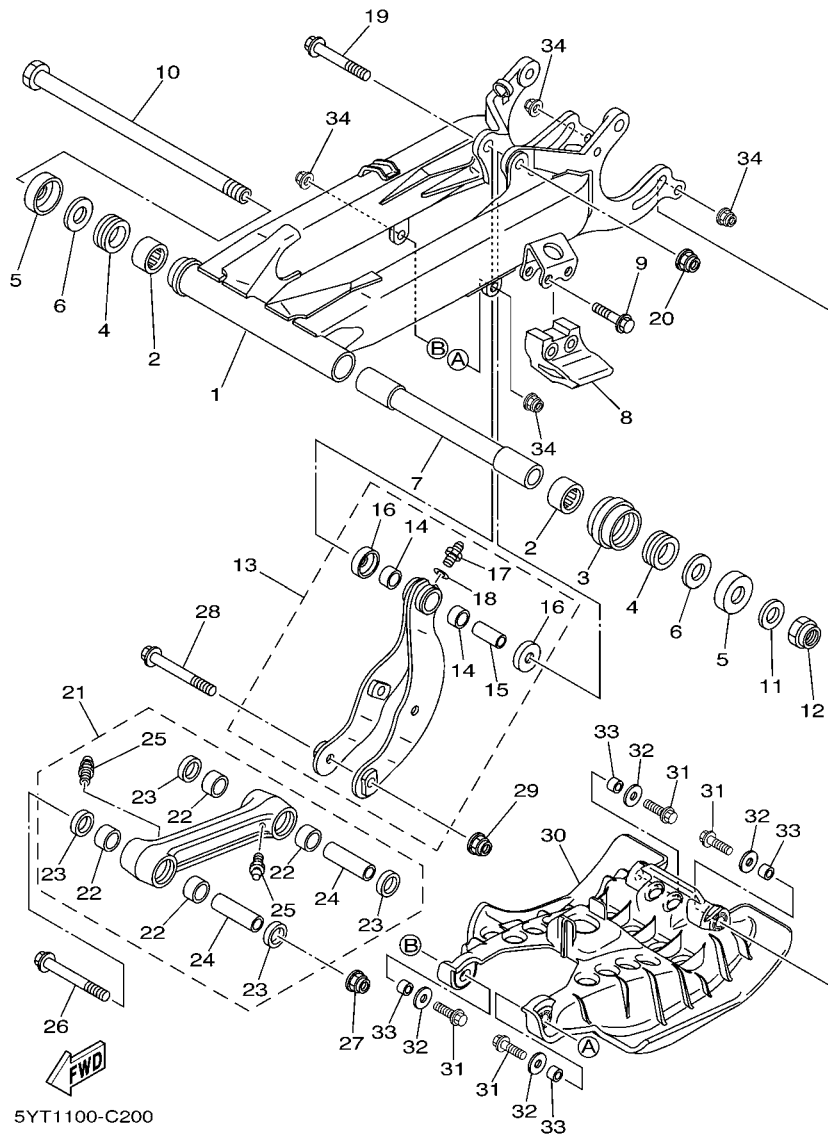

REF. NO.	PART NO.	DESCRIPTION	USA	CAN	EUR	OCE	JPN	REMARKS
1	3GD-22110-30	REAR ARM COMP.	1	1	1	1	1	
2	93317-22237	BEARING	2	2	2	2	2	
3	2GU-22151-00	SEAL, GUARD	1	1	1	1	1	
4	93108-35004	OIL SEAL (35-41-8)	2	2	2	2	2	
5	2K6-22128-01	COVER, THRUST 1	2	2	2	2	2	
6	90201-244A9	WASHER, PLATE (2.05T)	2	2	2	2	2	
7	3GD-22184-00	BUSH	1	1	1	1	1	
8	38W-22199-00	SUPPORT, CHAIN	1	1	1	1	1	
9	95802-08040	BOLT, FLANGE	2	2	2	2	2	
10	1UY-22141-10	SHAFT, PIVOT	1	1	1	1	1	
11	90201-16018	WASHER, PLATE	1	1	1	1	1	
12	90185-16002	NUT, SELF-LOCKING	1	1	1	1	1	
13	5YT-2210J-00	RELAY ARM SUB ASSY	1	1	1	1	1	
14	90383-20032	.BUSH, FORMED	2	2	2	2	2	
15	90387-125N8	.COLLAR	1	1	1	1	1	
16	5YT-22129-00	.COVER, THRUST 2	2	2	2	2	2	
17	93700-06004	.NIPPLE, GREASE	1	1	1	1	1	
18	90201-063F3	.WASHER, PLATE	1	1	1	1	1	
19	90105-12050	BOLT, FLANGE	1	1	1	1	1	
20	95602-12200	NUT, SELF-LOCKING	1	1	1	1	1	
21	5YT-2210K-00	CONNECTING ROD SUB ASSY	1	1	1	1	1	
22	90383-20032	.BUSH, FORMED	4	4	4	4	4	
23	93109-20076	.OIL SEAL	4	4	4	4	4	
24	90387-12021	.COLLAR	2	2	2	2	2	
25	93700-06004	.NIPPLE, GREASE	2	2	2	2	2	
26	90105-12061	BOLT, FLANGE	1	1	1	1	1	
27	95602-12200	NUT, SELF-LOCKING	1	1	1	1	1	

FIG. 21 REAR SUSPENSION

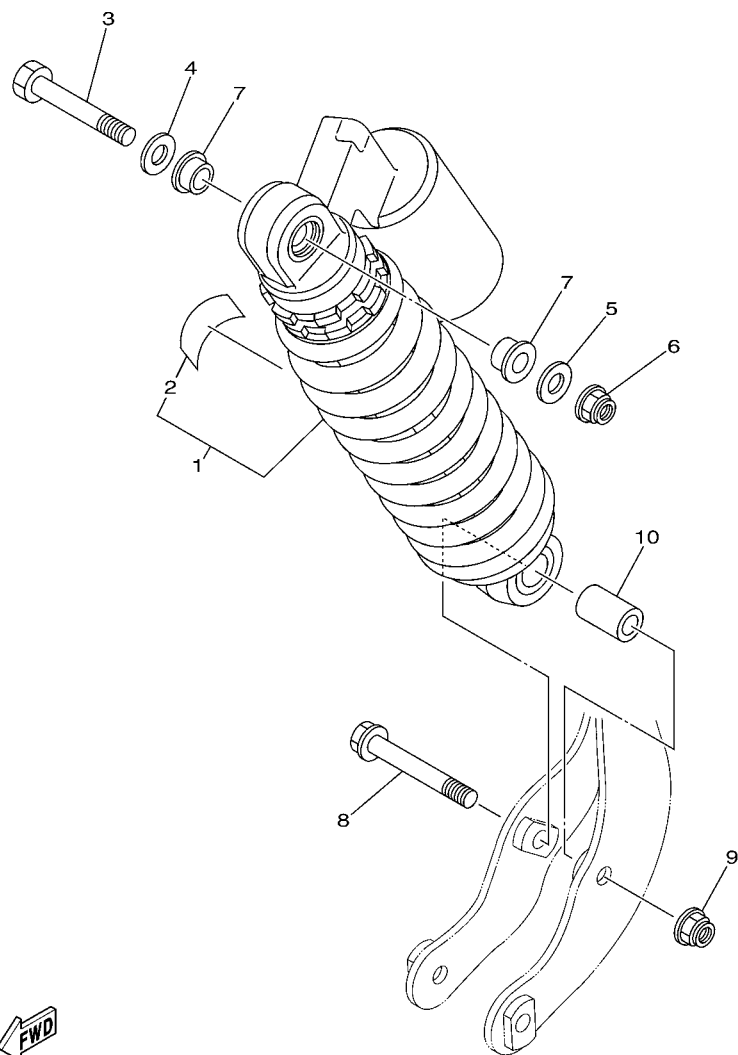

5YT1100-C211

REF. NO.	PART NO.	DESCRIPTION	USA	CAN	EUR	OCE	JPN	REMARKS
1	5YT-22210-00	SHOCK ABSORBER ASSY, REAR	1					UR FOR DPBSE
	5YT-22210-40	SHOCK ABSORBER ASSY, REAR	1					UR FOR PGD
	5YT-22210-10	SHOCK ABSORBER ASSY, REAR		1				UR FOR DPBSE
	5YT-22210-50	SHOCK ABSORBER ASSY, REAR		1				UR FOR PGD
	5YT-22210-20	SHOCK ABSORBER ASSY, REAR			1	1		UR FOR DPBSE
	5YT-22210-60	SHOCK ABSORBER ASSY, REAR			1	1		UR FOR PGD
	5YT-22210-30	SHOCK ABSORBER ASSY, REAR					1	FOR DPBSE
2	4AA-22259-80	.LABEL, WARNING	1					
	4AA-22259-70	.LABEL, WARNING		1				
	4AA-22259-40	.LABEL, WARNING			1	1		
	4AA-22259-50	.LABEL, WARNING					1	
3	90101-12012	BOLT	1	1	1	1	1	
4	90201-12033	WASHER, PLATE	1	1	1	1	1	
5	90201-12032	WASHER, PLATE	1	1	1	1	1	
6	90185-12007	NUT, SELF-LOCKING	1	1	1	1	1	
7	90387-127G8	COLLAR	2	2	2	2	2	
8	90105-12050	BOLT, FLANGE	1	1	1	1	1	
9	95602-12200	NUT, SELF-LOCKING	1	1	1	1	1	
10	90387-12020	COLLAR	1	1	1	1	1	

FIG. 22 STEERING

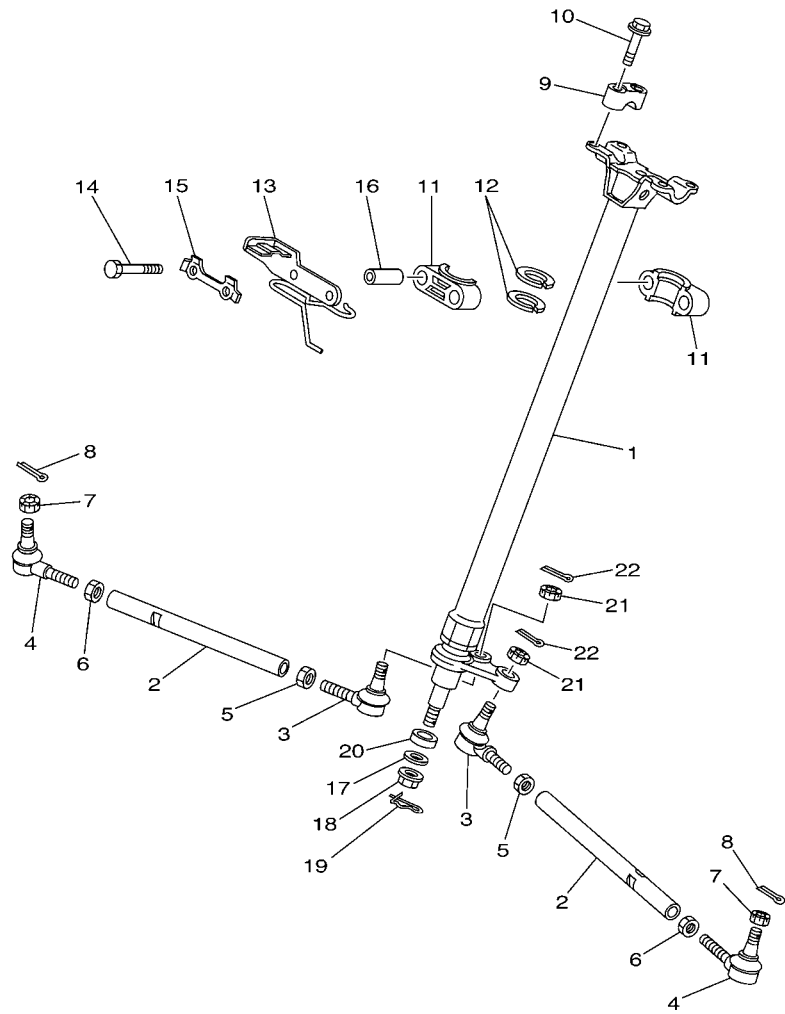

5YT1100-C220

REF. NO.	PART NO.	DESCRIPTION	USA	CAN	EUR	OCE	JPN	REMARKS
1	5YT-23813-20	COLUMN, STEERING 2	1	1	1	1	1	
2	3GD-23831-00	ROD, TIE	2	2	2	2	2	
3	1UY-23841-01	JOINT, UNIVERSAL 1	2	2	2	2	2	
4	1UY-23845-01	JOINT, UNIVERSAL 2	2	2	2	2	2	
5	95302-10700	NUT	2	2	2	2	2	
6	90170-10010	NUT	2	2	2	2	2	(L.H. THREAD)
7	90171-10001	NUT, CASTLE	2	2	2	2	2	
8	91401-20020	PIN, COTTER	2	2	2	2	2	
9	8K1-23814-00	HOLDER, HANDLE	2	2	2	2	2	
10	95822-08030	BOLT, FLANGE	4	4	4	4	4	
11	1UY-23812-00	PLANE BEARING, STEERING	2	2	2	2	2	
12	93112-31011	OIL SEAL	2	2	2	2	2	
13	5YT-23868-00	BRACKET, STEERING LOWER	1	1	1	1	1	
14	97022-08060	BOLT	2	2	2	2	2	
15	1UY-23894-01	WASHER, LOCK 1	1	1	1	1	1	
16	90387-090R0	COLLAR	2	2	2	2	2	
17	90201-10036	WASHER, PLATE	1	1	1	1	1	
18	90185-10019	NUT, SELF-LOCKING	1	1	1	1	1	
19	90468-16191	CLIP	1	1	1	1	1	
20	90387-176R6	COLLAR	1	1	1	1	1	
21	90171-10001	NUT, CASTLE	2	2	2	2	2	
22	91401-20020	PIN, COTTER	2	2	2	2	2	

FIG. 23 FRONT SUSPENSION & WHEEL

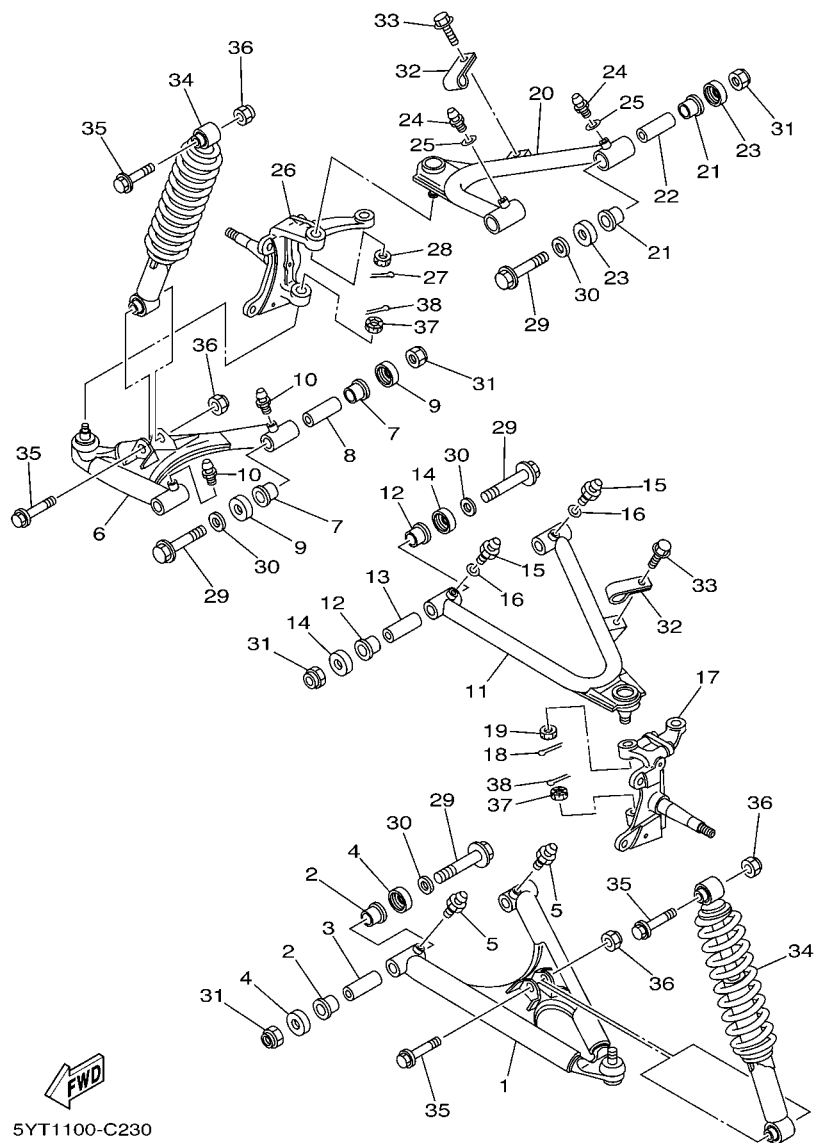

5YT1100-C230

REF. NO.	PART NO.	DESCRIPTION	USA	CAN	EUR	OCE	JPN	REMARKS
1	3GD-23570-20	FRONT LOWER ARM COMP. (LEFT)	1	1	1	1	1	UR FOR DPBSE
	3GD-23570-10	FRONT LOWER ARM COMP. (LEFT)	1	1	1	1	1	UR FOR PGD
2	90381-15088	BUSH, SOLID	4	4	4	4	4	
3	90387-101R3	COLLAR	2	2	2	2	2	
4	5YT-23517-00	COVER, THRUST 1	4	4	4	4	4	
5	93700-06004	NIPPLE, GREASE	2	2	2	2	2	
6	3GD-23580-20	FRONT LOWER ARM COMP. (RIGHT)	1	1	1	1	1	UR FOR DPBSE
	3GD-23580-10	FRONT LOWER ARM COMP. (RIGHT)	1	1	1	1	1	UR FOR PGD
7	90381-15088	BUSH, SOLID	4	4	4	4	4	
8	90387-101R3	COLLAR	2	2	2	2	2	
9	5YT-23517-00	COVER, THRUST 1	4	4	4	4	4	
10	93700-06004	NIPPLE, GREASE	2	2	2	2	2	
11	3GD-23540-20	FRONT UPPER ARM COMP. (LEFT)	1	1	1	1	1	UR FOR DPBSE
	3GD-23540-10	FRONT UPPER ARM COMP. (LEFT)	1	1	1	1	1	UR FOR PGD
12	90381-15088	BUSH, SOLID	4	4	4	4	4	
13	90387-101R3	COLLAR	2	2	2	2	2	
14	5YT-23517-00	COVER, THRUST 1	4	4	4	4	4	
15	93700-06004	NIPPLE, GREASE	2	2	2	2	2	
16	90201-063F3	WASHER, PLATE	2	2	2	2	2	
17	3GD-23501-10	STEERING KNUCKLE ASSY (LEFT)	1	1	1	1	1	
18	91401-20020	PIN, COTTER	1	1	1	1	1	
19	90171-10001	NUT, CASTLE	1	1	1	1	1	
20	3GD-23550-20	FRONT UPPER ARM COMP. (RIGHT)	1	1	1	1	1	UR FOR DPBSE
	3GD-23550-10	FRONT UPPER ARM COMP. (RIGHT)	1	1	1	1	1	UR FOR PGD
21	90381-15088	BUSH, SOLID	4	4	4	4	4	
22	90387-101R3	COLLAR	2	2	2	2	2	
23	5YT-23517-00	COVER, THRUST 1	4	4	4	4	4	

D6

FIG. 23 FRONT SUSPENSION & WHEEL

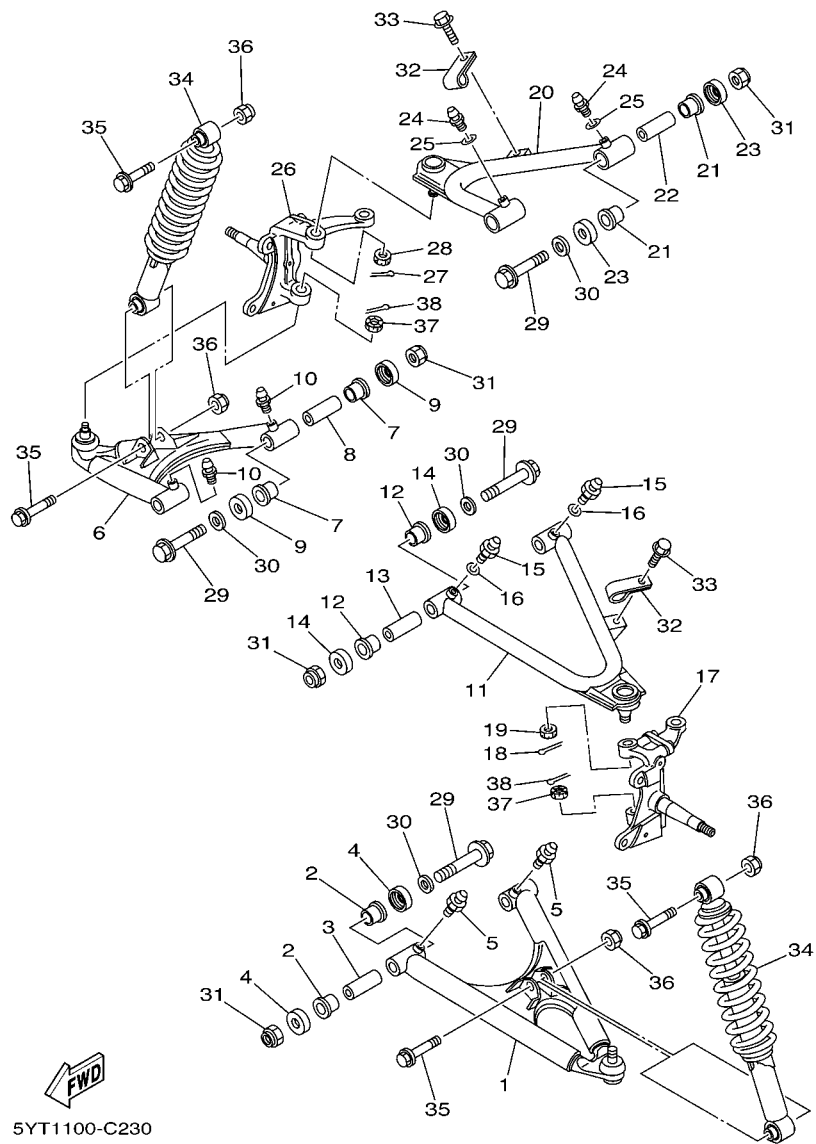

5YT1100-C230

REF. NO.	PART NO.	DESCRIPTION	USA	CAN	EUR	OCE	JPN	REMARKS
24	93700-06004	NIPPLE, GREASE	2	2	2	2	2	
25	90201-063F3	WASHER, PLATE	2	2	2	2	2	
26	3GD-23502-10	STEERING KNUCKLE ASSY (RIGHT)	1	1	1	1	1	
27	91401-20020	PIN, COTTER	1	1	1	1	1	
28	90171-10001	NUT, CASTLE	1	1	1	1	1	
29	90105-10135	BOLT, FLANGE	8	8	8	8	8	
30	90201-10037	WASHER, PLATE	8	8	8	8	8	
31	90185-10012	NUT, SELF-LOCKING	8	8	8	8	8	
32	5VM-25886-10	HOLDER, BRAKE HOSE	2	2	2	2	2	
33	95822-06016	BOLT, FLANGE	2	2	2	2	2	
34	5YT-23350-00	SHOCK ABSORBER ASSY	2	2	2	2	2	UR FOR DPBSE
	5YT-23350-10	SHOCK ABSORBER ASSY	2	2	2	2	2	UR FOR PGD
35	90105-10131	BOLT, FLANGE	4	4	4	4	4	
36	90185-10012	NUT, SELF-LOCKING	4	4	4	4	4	
37	90171-10001	NUT, CASTLE	2	2	2	2	2	
38	91401-20020	PIN, COTTER	2	2	2	2	2	

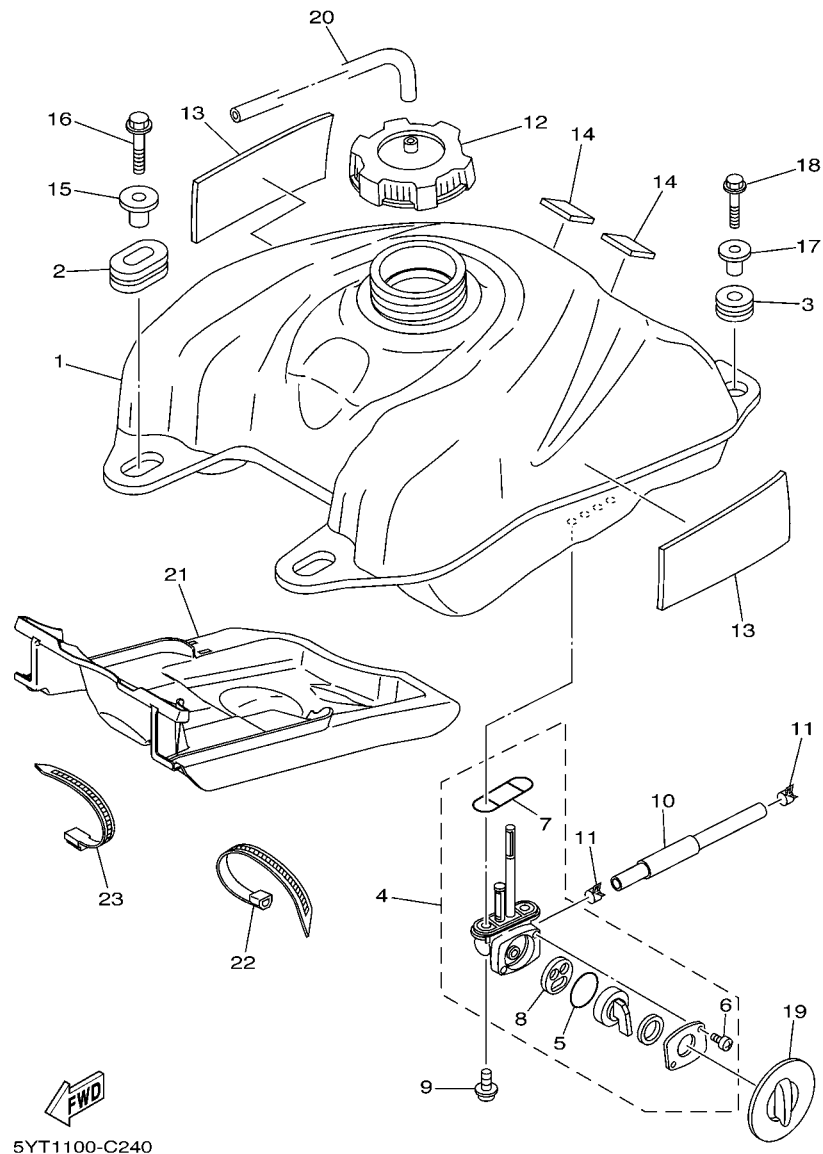
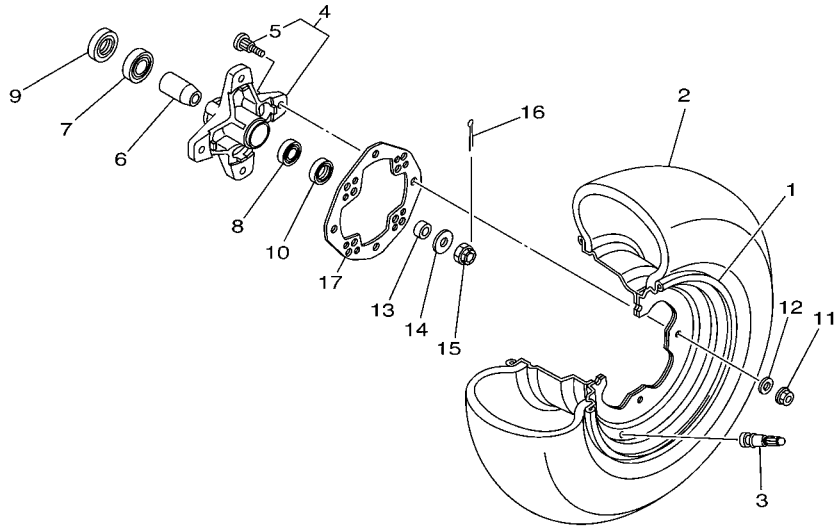
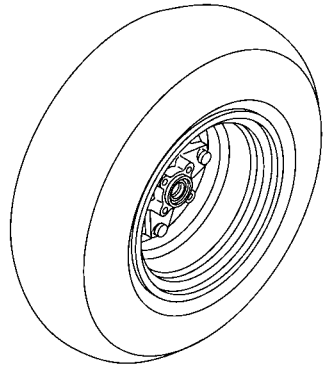

FIG. 24 FUEL TANK

REF. NO.	PART NO.	DESCRIPTION	USA	CAN	EUR	OCE	JPN	REMARKS
1	5YT-24110-10	FUEL TANK COMP.	1	1				
	5YT-24110-00	FUEL TANK COMP.			1	1	1	
2	90480-01400	GROMMET	2	2	2	2	2	
3	90480-18290	GROMMET	2	2	2	2	2	
4	21V-24500-11	FUEL COCK ASSY 1	1	1	1	1	1	
5	3AJ-24534-01	.SEAL, COCK	1	1	1	1	1	
6	98507-03008	.SCREW, PAN HEAD	2	2	2	2	2	
7	4X8-24512-00	.O-RING	1	1	1	1	1	
8	3AC-24523-00	.VALVE PACKING	1	1	1	1	1	
9	90149-06108	SCREW	2	2	2	2	2	
10	5YT-24311-10	PIPE, FUEL 1	1	1				
	5YT-24311-00	PIPE, FUEL 1			1	1	1	
11	90467-10038	CLIP	2	2	2	2	2	
12	5KM-24610-00	CAP ASSY	1	1	1	1	1	
13	5TG-21541-00	DAMPER 1	2	2	2	2	2	
14	5YT-24665-00	DAMPER	2	2	2	2	2	
15	90387-07021	COLLAR	2	2	2	2	2	
16	95802-06030	BOLT, FLANGE	2	2	2	2	2	
17	90387-066J1	COLLAR	2	2	2	2	2	
18	95802-06030	BOLT, FLANGE	2	2	2	2	2	
19	5YT-24524-00	LEVER, COCK	1	1	1	1	1	
20	90445-084J1	HOSE (L420)	1	1	1	1	1	
21	5YT-2414H-00	DAMPER, PLATE 1	1	1	1	1	1	
22	90464-15195	CLAMP	1	1	1	1	1	
23	90464-13073	CLAMP	1	1	1	1	1	



5YT1100-C260

FIG. 26 FRONT WHEEL

REF. NO.	PART NO.	DESCRIPTION	USA	CAN	EUR	OCE	JPN	REMARKS
1	5LP-25180-20	WHEEL COMP.	2	2	2	2	2	
2	94107-10020	TIRE (AT21X7-10 KT851B T/L)	2	2	2	2	2	DUNLOP
3	93900-00022	VALVE, RIM (TR413)	2	2	2	2	2	TAIHEIYO
4	3GD-25111-20	HUB, FRONT	2	2	2	2	2	
5	90114-10006	BOLT, SERRATION	4	4	4	4	4	
6	1UY-25117-00	SPACER, BEARING	2	2	2	2	2	
7	93306-00446	BEARING	2	2	2	2	2	
8	93306-20231	BEARING	2	2	2	2	2	
9	93105-26026	OIL SEAL	2	2	2	2	2	
10	93102-22216	OIL SEAL	2	2	2	2	2	
11	95702-10500	NUT, WITH WASHER	8	8	8	8	8	
12	92902-10200	WASHER	8	8	8	8	8	
13	90387-150R1	COLLAR	2	2	2	2	2	
14	90201-14586	WASHER, PLATE	2	2	2	2	2	
15	90171-14002	NUT, CASTLE	2	2	2	2	2	
16	91401-30025	PIN, SPLIT	2	2	2	2	2	
17	1S3-25127-00	COVER, PLATE	2	2	2	2	2	

D10

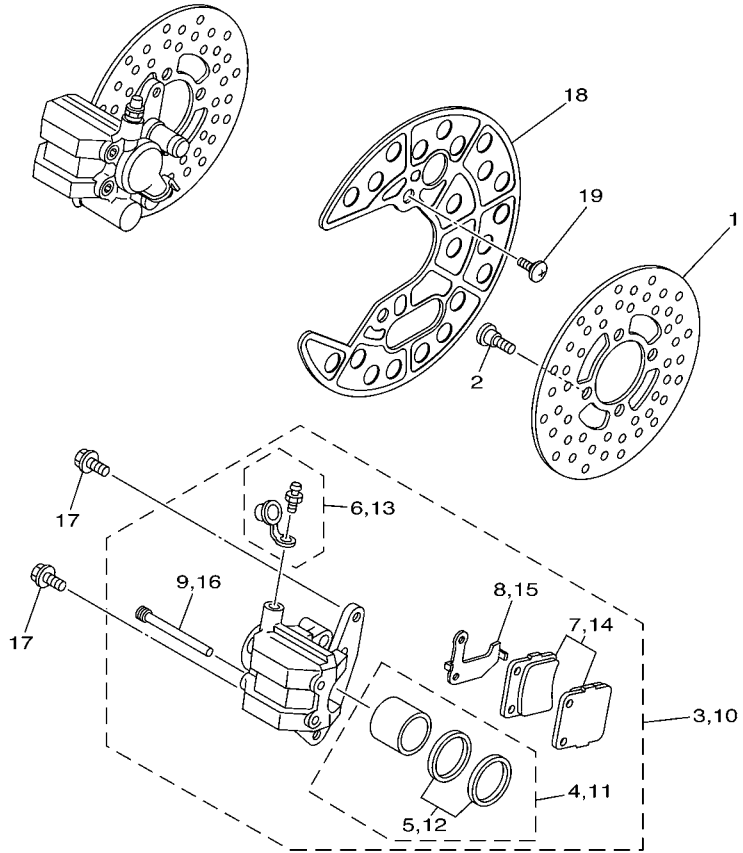

FIG. 27 FRONT BRAKE CALIPER

REF. NO.	PART NO.	DESCRIPTION	USA	CAN	EUR	OCE	JPN	REMARKS
1	3GD-2582T-10	DISC, BRAKE (LEFT)	2	2	2	2	2	
2	90109-08082	BOLT	8	8	8	8	8	
3	5LP-2580T-00	CALIPER ASSY (LEFT)	1	1	1	1	1	
4	3GD-W0057-00	.PISTON ASSY, CALIPER	1	1	1	1	1	
5	3GD-W0047-00	..CALIPER SEAL KIT	1	1	1	1	1	
6	1UY-W0048-50	.BLEED SCREW KIT	1	1	1	1	1	
7	5LP-W0045-00	.BRAKE PAD KIT	1	1	1	1	1	
8	3GD-25827-00	.SHIM, CALIPER	1	1	1	1	1	
9	3GD-25933-00	.PIN, PAD	2	2	2	2	2	
10	5LP-2580U-00	CALIPER ASSY (RIGHT)	1	1	1	1	1	
11	3GD-W0057-00	.PISTON ASSY, CALIPER	1	1	1	1	1	
12	3GD-W0047-00	..CALIPER SEAL KIT	1	1	1	1	1	
13	1UY-W0048-50	.BLEED SCREW KIT	1	1	1	1	1	
14	5LP-W0045-00	.BRAKE PAD KIT	1	1	1	1	1	
15	3GD-25828-00	.SHIM, CALIPER	1	1	1	1	1	
16	3GD-25933-00	.PIN, PAD	2	2	2	2	2	
17	90105-08161	BOLT, FLANGE	4	4	4	4	4	
18	5YT-2514A-00	RING, WHEEL 1 (LEFT)	2	2	2	2	2	
19	90154-06014	SCREW, BINDING	4	4	4	4	4	



5YT1100-C270

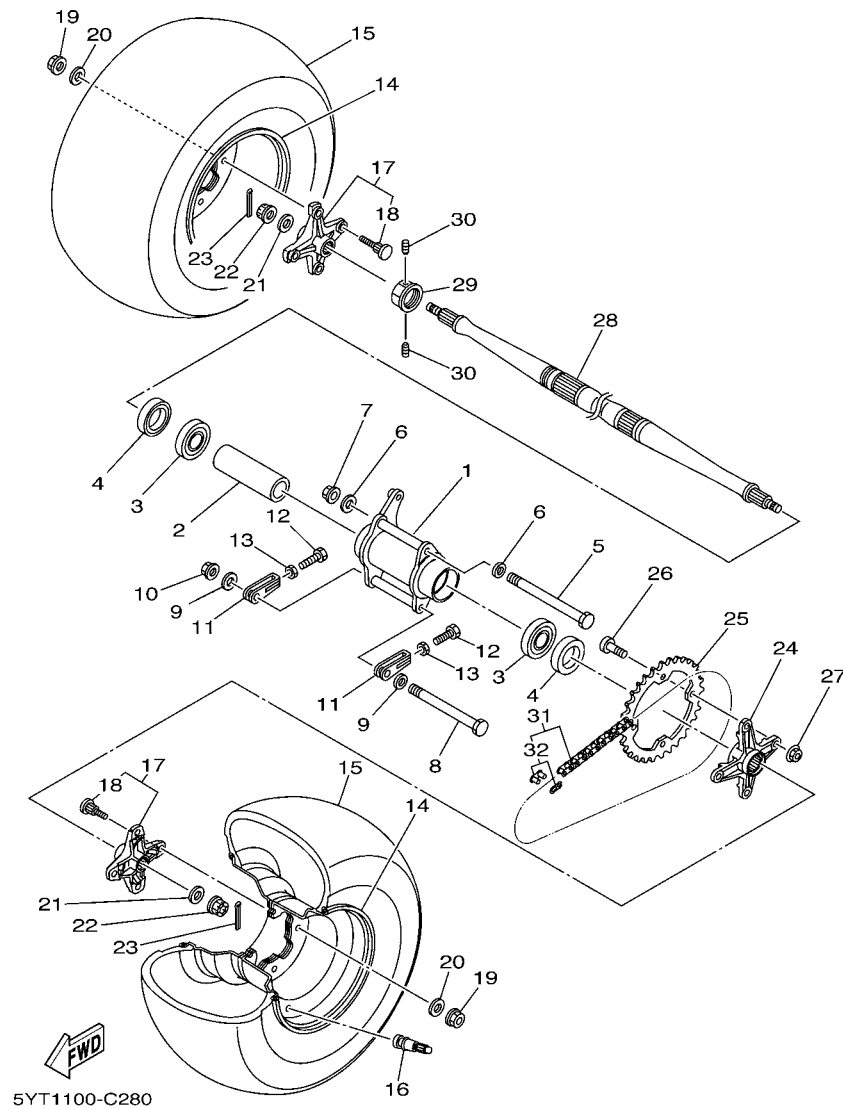
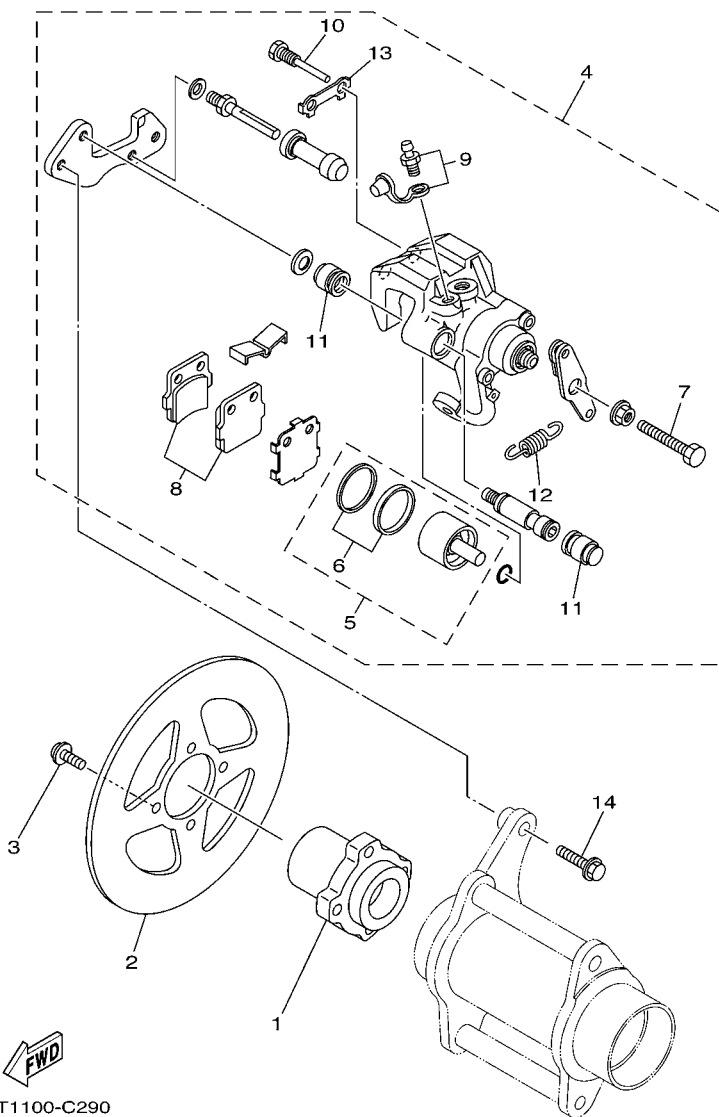

FIG. 28 REAR WHEEL

REF. NO.	PART NO.	DESCRIPTION	USA	CAN	EUR	OC	JPN	REMARKS
1	5YT-25311-00	HUB, REAR	1	1	1	1	1	
2	5YT-25317-00	SPACER, BEARING	1	1	1	1	1	
3	93306-00710	BEARING	2	2	2	2	2	
4	93106-46001	OIL SEAL	2	2	2	2	2	
5	90101-12032	BOLT	1	1	1	1	1	
6	90201-12045	WASHER, PLATE	2	2	2	2	2	
7	90179-12009	NUT	1	1	1	1	1	
8	90101-10029	BOLT	1	1	1	1	1	
9	90201-10052	WASHER, PLATE	2	2	2	2	2	
10	90179-10024	NUT	1	1	1	1	1	
11	3GD-25388-00	PULLER, CHAIN 1	2	2	2	2	2	
12	90101-08006	BOLT	2	2	2	2	2	
13	95302-08600	NUT	2	2	2	2	2	
14	5LP-25390-20	REAR WHEEL COMP.	2	2	2	2	2	
15	94110-09020	TIRE (AT20X10-9 KT877 T/L)	2	2	2	2	2	DUNLOP
16	93900-00022	VALVE, RIM (TR413)	2	2	2	2	2	TAIHEIYO
17	1S3-25383-20	COLLAR, WHEEL	2	2	2	2	2	
18	90114-10013	.BOLT, SERRATION	4	4	4	4	4	
19	95702-10500	NUT, WITH WASHER	8	8	8	8	8	
20	92902-10200	WASHER	8	8	8	8	8	
21	90201-14021	WASHER, PLATE	2	2	2	2	2	
22	90171-14004	NUT, CASTLE	2	2	2	2	2	
23	91401-30030	PIN, COTTER	2	2	2	2	2	
24	5YT-25386-00	COLLAR, SPROCKET AXLE	1	1	1	1	1	
25	5TG-25438-10	SPROCKET, DRIVEN (38T)	1	1	1	1	1	
26	90109-10013	BOLT	4	4	4	4	4	
27	90185-10011	NUT, SELF-LOCKING	4	4	4	4	4	

FIG. 29 REAR BRAKE



5YT1100-C290

REF. NO.	PART NO.	DESCRIPTION	USA	CAN	EUR	OCE	JPN	REMARKS
1	5YT-25712-00	BRACKET, DISC	1	1	1	1	1	
2	5TG-2582W-00	DISK, REAR BRAKE 2	1	1	1	1	1	
3	90109-081F0	BOLT	4	4	4	4	4	
4	5YT-2580W-00	CALIPER ASSY, REAR 2	1	1	1	1	1	
5	5LP-W0057-50	.PISTON ASSY, CALIPER	1	1	1	1	1	
6	5LP-W0047-50	..CALIPER SEAL KIT	1	1	1	1	1	
7	1UY-25972-51	.ADJUSTBOLT	1	1	1	1	1	
8	5LP-W0046-50	.BRAKE PAD KIT 2	1	1	1	1	1	
9	1UY-W0048-50	.BLEED SCREW KIT	1	1	1	1	1	
10	1UY-25924-51	.PIN, PAD	2	2	2	2	2	
11	1UY-25917-51	.BOOT, CALIPER	2	2	2	2	2	
12	5YT-25977-50	.SPRING, RETURN	1	1	1	1	1	
13	1UY-25933-51	.WASHER, PAD PIN	1	1	1	1	1	
14	90105-08182	BOLT, FLANGE	2	2	2	2	2	

FIG. 30 STEERING HANDLE & CABLE

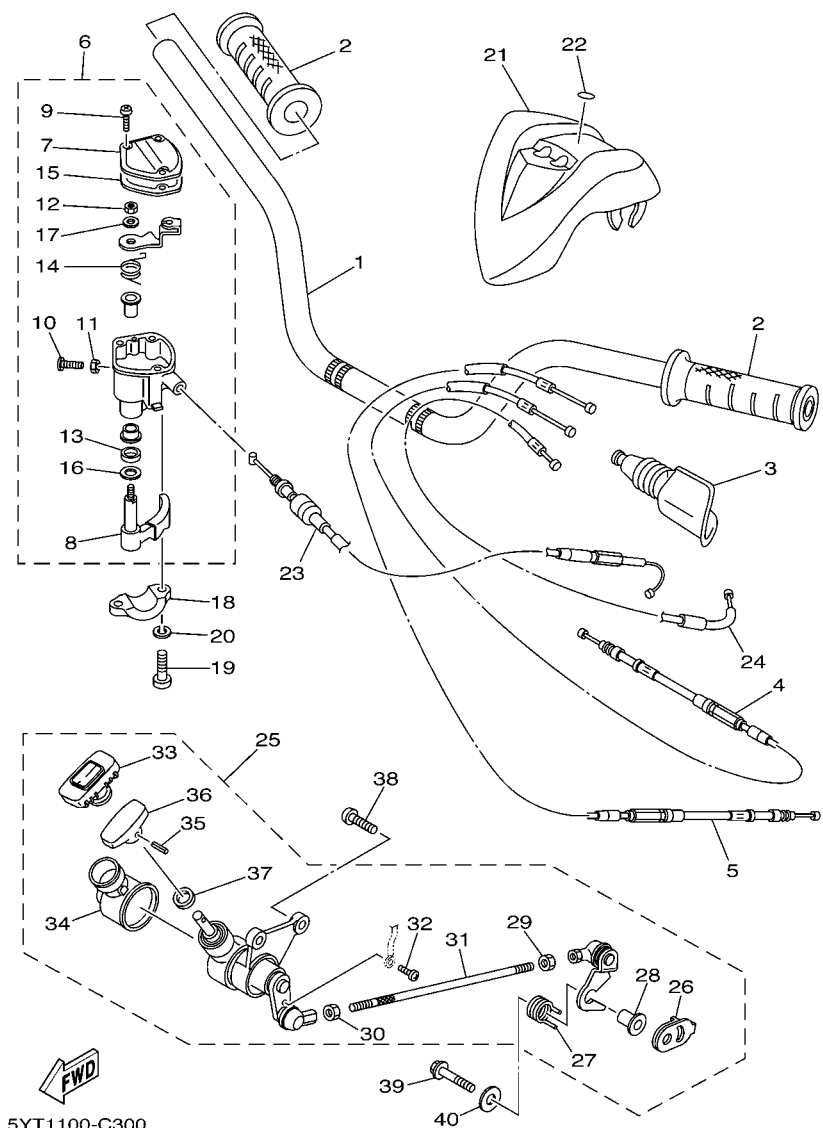

5YT1100-C300

REF. NO.	PART NO.	DESCRIPTION	USA	CAN	EUR	OCE	JPN	REMARKS
1	5YT-26111-10	HANDLEBAR	1	1	1	1	1	
2	5LP-26241-00	GRIP	2	2	2	2	2	
3	31A-26372-00	COVER, HANDLE LEVER 1	1	1	1	1	1	
4	5YT-26335-10	CABLE, CLUTCH	1	1	1	1	1	
5	5YT-26341-01	WIRE, BRAKE 1	1	1	1	1	1	
6	4KB-26250-20	THROTTLE LEVER ASSY	1	1	1	1	1	
7	4KB-2628F-20	.CAP, GEAR	1	1	1	1	1	
8	1NV-2625G-01	.LEVER, THROTTLE	1	1	1	1	1	
9	4KB-2632G-00	.SCREW	3	3	3	3	3	
10	4KB-26256-00	.SCREW, GRIP END	1	1	1	1	1	
11	95607-05100	.NUT, U	1	1	1	1	1	
12	4KB-26258-00	.NUT, LOCK	1	1	1	1	1	
13	93104-09025	.OIL SEAL	1	1	1	1	1	
14	1NV-26304-00	.SPRING	1	1	1	1	1	
15	4KB-2628G-00	.GASKET	1	1	1	1	1	
16	1NV-26129-00	.WASHER	1	1	1	1	1	
17	1NV-26398-00	.WASHER	1	1	1	1	1	
18	4V4-82913-00	HOLDER, LEVER LOWER 1	1	1	1	1	1	
19	98502-05020	SCREW, PAN HEAD	2	2	2	2	2	
20	92902-05600	WASHER, PLATE	2	2	2	2	2	
21	5YT-26124-00	PROTECTOR, HANDLEBAR	1	1	1	1	1	UR FOR DPBSE
	5YT-26124-20	PROTECTOR, HANDLEBAR	1	1	1	1	1	UR FOR PGD
22	5GT-2836B-10	TUNING FORK MARK	1	1	1	1	1	
23	5YT-26311-10	CABLE, THROTTLE 1	1	1	1	1	1	
24	5YT-26331-00	CABLE, STARTER 1	1	1	1	1	1	
25	5YT-26150-20	REV. LEVER ASSY.	1	1	1	1	1	
26	4SH-18198-00	.LEVER	1	1	1	1	1	

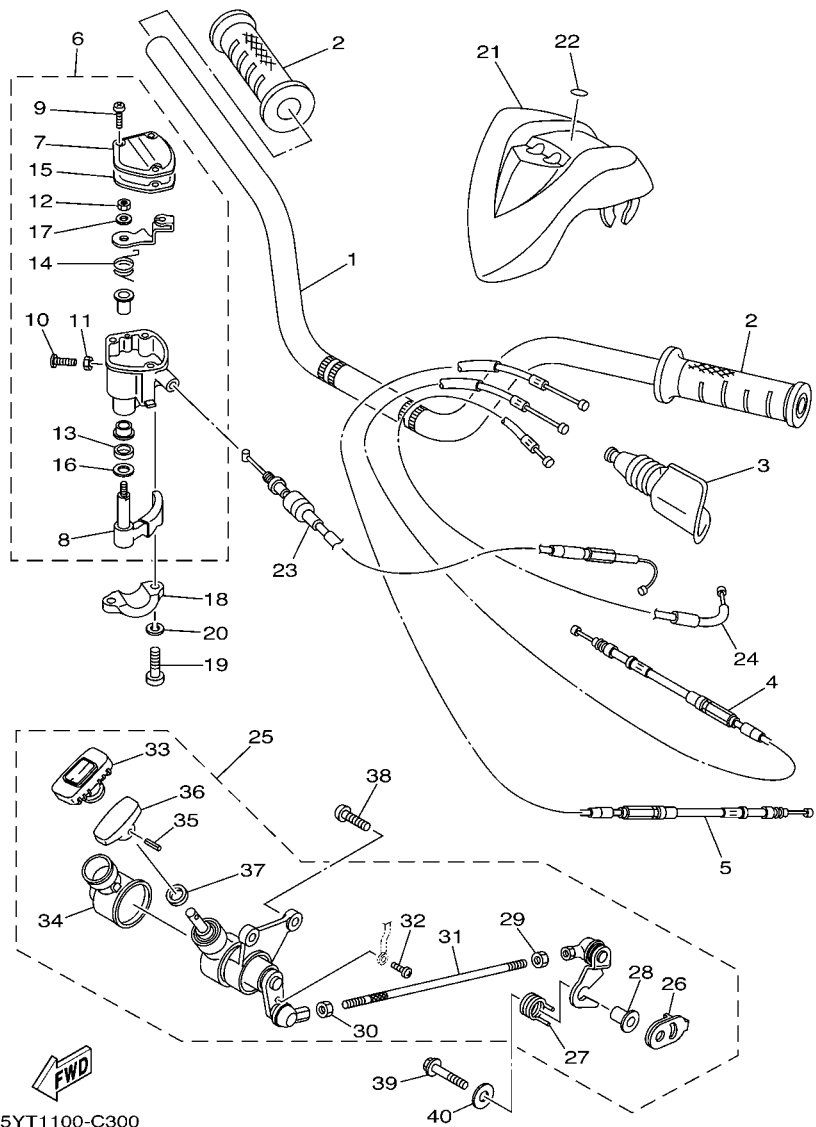

5YT1100-C300

FIG. 30 STEERING HANDLE & CABLE

REF. NO.	PART NO.	DESCRIPTION	USA	CAN	EUR	OCE	JPN	REMARKS
27	90508-35764	.SPRING, TORSION	1	1	1	1	1	
28	90387-063W7	.COLLAR	1	1	1	1	1	
29	95317-06700	.NUT	1	1	1	1	1	
30	90170-06023	.NUT	1	1	1	1	1	
31	3GD-26166-10	.ROD, JOINT	1	1	1	1	1	
32	98502-04008	.SCREW, PAN HEAD	1	1	1	1	1	
33	1UY-26153-00	.GRIP, LEVER	1	1	1	1	1	
34	1UY-26372-00	.COVER, HANDLE LEVER 1	1	1	1	1	1	
35	91609-40016	.PIN, SPRING	1	1	1	1	1	
36	1UY-26157-00	.LEVER, LOCK	1	1	1	1	1	
37	93109-08050	.OIL SEAL	1	1	1	1	1	
38	92012-08020	BOLT, BUTTON HEAD	2	2	2	2	2	
39	95812-06035	BOLT, FLANGE	1	1	1	1	1	
40	90201-06036	WASHER, PLATE	1	1	1	1	1	

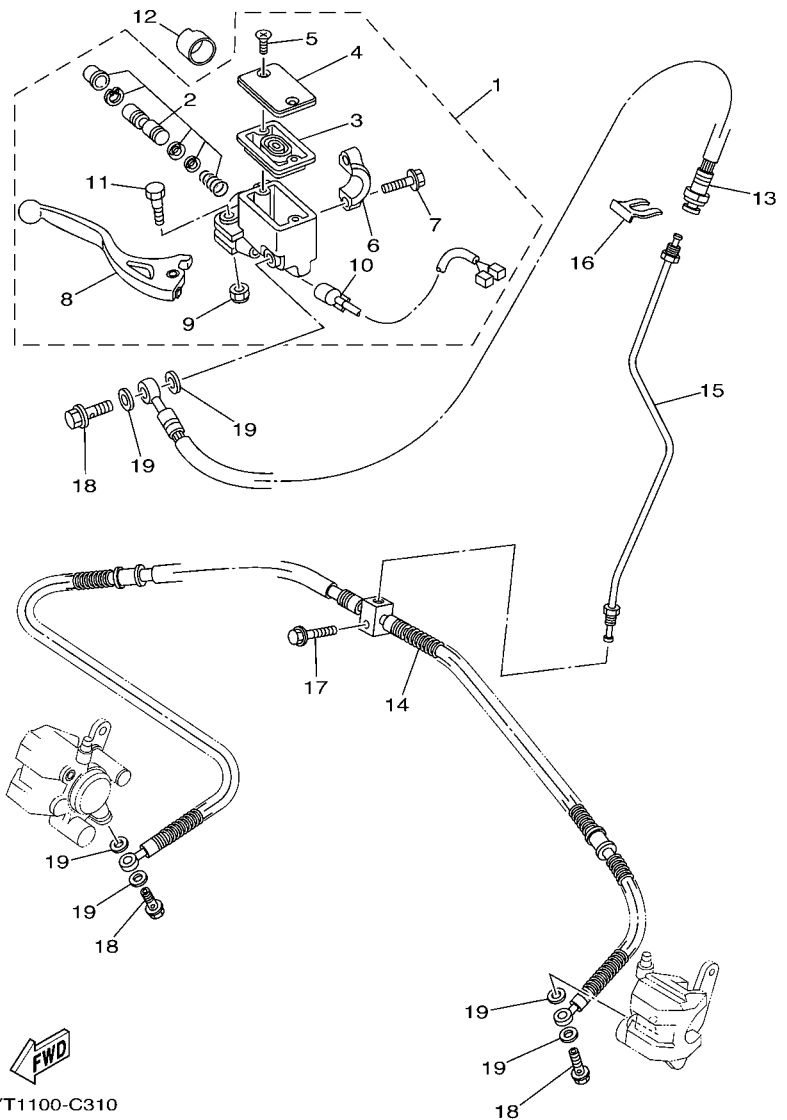
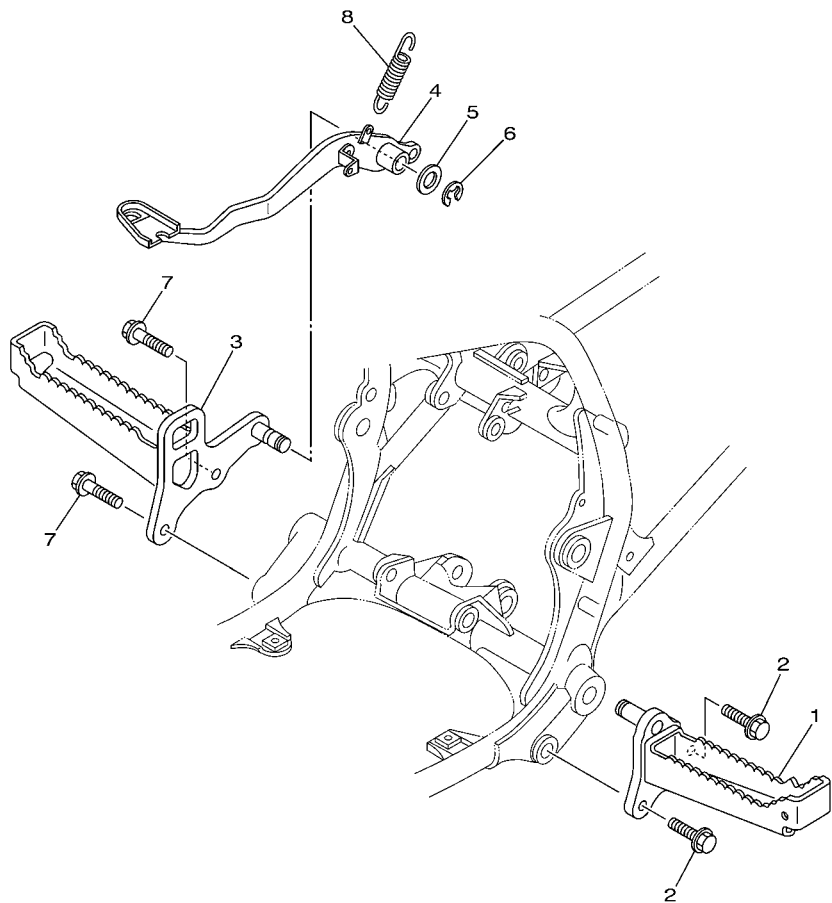

FIG. 31 FRONT MASTER CYLINDER

REF. NO.	PART NO.	DESCRIPTION	USA	CAN	EUR	OCE	JPN	REMARKS
1	5LP-2583T-01	MASTER CYLINDER ASSY	1	1	1	1	1	
2	5LP-W0041-00	.CYLINDER KIT, MASTER	1	1	1	1	1	
3	4L0-25854-00	.DIAPHRAGM, RESERVOIR	1	1	1	1	1	
4	5LP-25852-01	.CAP, RESERVOIR	1	1	1	1	1	
5	4NK-2589H-00	.SCREW	2	2	2	2	2	
6	5LP-25867-00	.BRACKET, MASTER CYLINDER	1	1	1	1	1	
7	5MV-25833-00	.BOLT, FITTING	2	2	2	2	2	
8	5LP-83922-00	.LEVER 2	1	1	1	1	1	
9	95604-06100	.NUT, U	1	1	1	1	1	
10	5LP-83980-00	.FRONT STOP SWITCH ASSY	1	1	1	1	1	
11	5MV-2589F-00	.BOLT, LEVER	1	1	1	1	1	
12	1UY-26259-00	COLLAR	1	1	1	1	1	
13	5YT-25872-10	HOSE, BRAKE 1	1	1	1	1	1	
14	5YT-25873-10	HOSE, BRAKE 2	1	1	1	1	1	
15	5YT-25871-10	PIPE, BRAKE	1	1	1	1	1	
16	2GU-25866-00	CIRCLIP	1	1	1	1	1	
17	95822-06025	BOLT, FLANGE	1	1	1	1	1	
18	90401-10015	BOLT, UNION	3	3	3	3	3	
19	90201-10118	WASHER, PLATE	6	6	6	6	6	

FIG. 32 STAND & FOOTREST



REF. NO.	PART NO.	DESCRIPTION	USA	CAN	EUR	OCE	JPN	REMARKS
1	5YT-27411-10	FOOTREST 1	1	1	1	1	1	
2	95812-10025	BOLT, FLANGE	2	2	2	2	2	
3	5YT-27421-10	FOOTREST 2	1	1	1	1	1	
4	5YT-27211-10	PEDAL, BRAKE	1	1	1	1	1	
5	90201-15018	WASHER, PLATE	1	1	1	1	1	
6	93430-12008	CIRCLIP	1	1	1	1	1	
7	95812-10025	BOLT, FLANGE	2	2	2	2	2	
8	90506-20026	SPRING, TENSION	1	1	1	1	1	

FWD
5YT1100-C320

FIG. 33 REAR MASTER CYLINDER

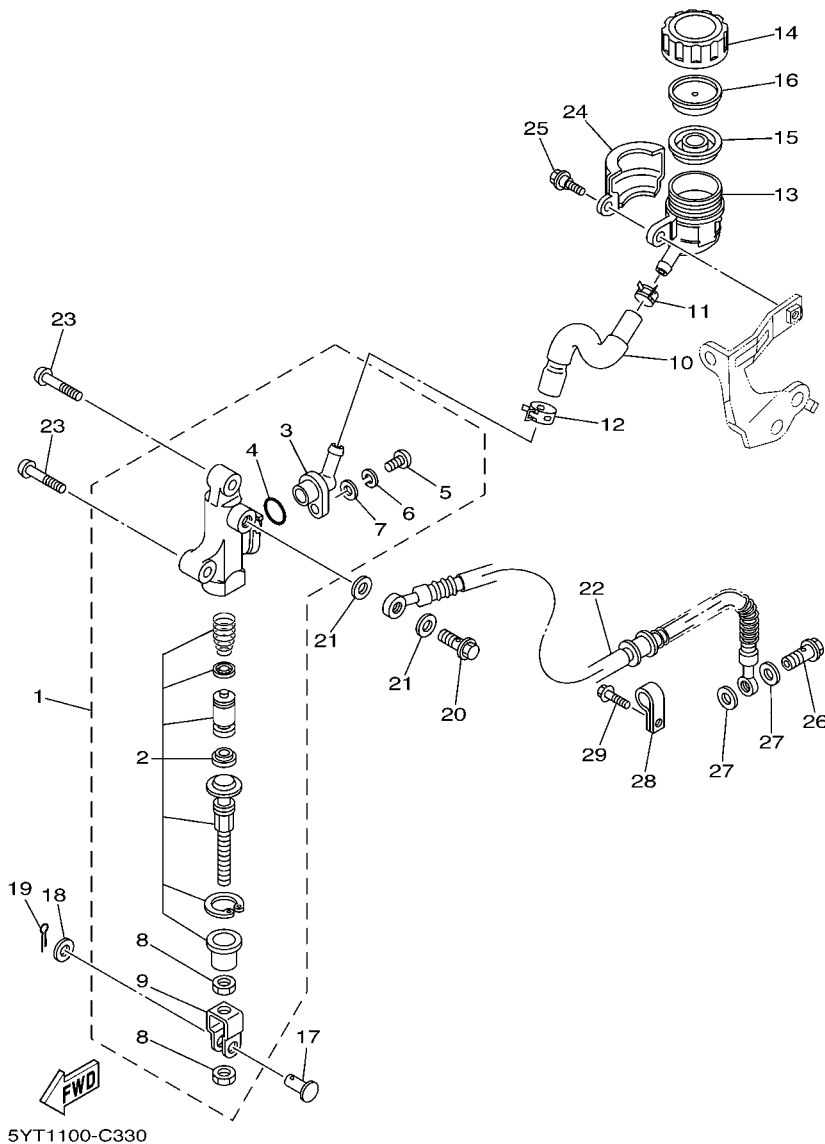

REF. NO.	PART NO.	DESCRIPTION	USA	CAN	EUR	OCE	JPN	REMARKS
1	5YT-2583V-00	RR. MASTER CYLINDER ASSY.	1	1	1	1	1	
2	5FK-W0042-50	.CYLINDER KIT, MASTER	1	1	1	1	1	
3	47X-2582A-50	.JOINT	1	1	1	1	1	
4	93210-15620	.O-RING	1	1	1	1	1	
5	98506-04012	.SCREW, PAN HEAD	1	1	1	1	1	
6	92906-04100	.WASHER, SPRING	1	1	1	1	1	
7	92906-04600	.WASHER, PLATE	1	1	1	1	1	
8	4SS-27218-00	.NUT	2	2	2	2	2	
9	2YK-27222-00	.JOINT	1	1	1	1	1	
10	5YT-25895-00	HOSE, RESERVOIR	1	1	1	1	1	
11	90467-11044	CLIP	1	1	1	1	1	
12	90467-140A6	CLIP	1	1	1	1	1	
13	4EW-25894-00	TANK, RESERVOIR	1	1	1	1	1	
14	3XP-25852-50	CAP, RESERVOIR	1	1	1	1	1	
15	2VN-25854-00	DIAPHRAGM, RESERVOIR	1	1	1	1	1	
16	2VN-25855-00	BUSH,DIAPHRAGM	1	1	1	1	1	
17	90240-08005	PIN, CLEVIS	1	1	1	1	1	
18	90201-08066	WASHER, PLATE	1	1	1	1	1	
19	91401-16012	PIN, COTTER	1	1	1	1	1	
20	90401-10015	BOLT, UNION	1	1	1	1	1	
21	90201-10118	WASHER, PLATE	2	2	2	2	2	
22	5YT-25874-10	HOSE, BRAKE	1	1	1	1	1	
23	92012-08030	BOLT, BUTTON HEAD	2	2	2	2	2	
24	5YT-25888-00	COVER, RESERVOIR TANK	1	1	1	1	1	
25	90109-06240	BOLT	1	1	1	1	1	
26	90401-10015	BOLT, UNION	1	1	1	1	1	
27	90201-10118	WASHER, PLATE	2	2	2	2	2	

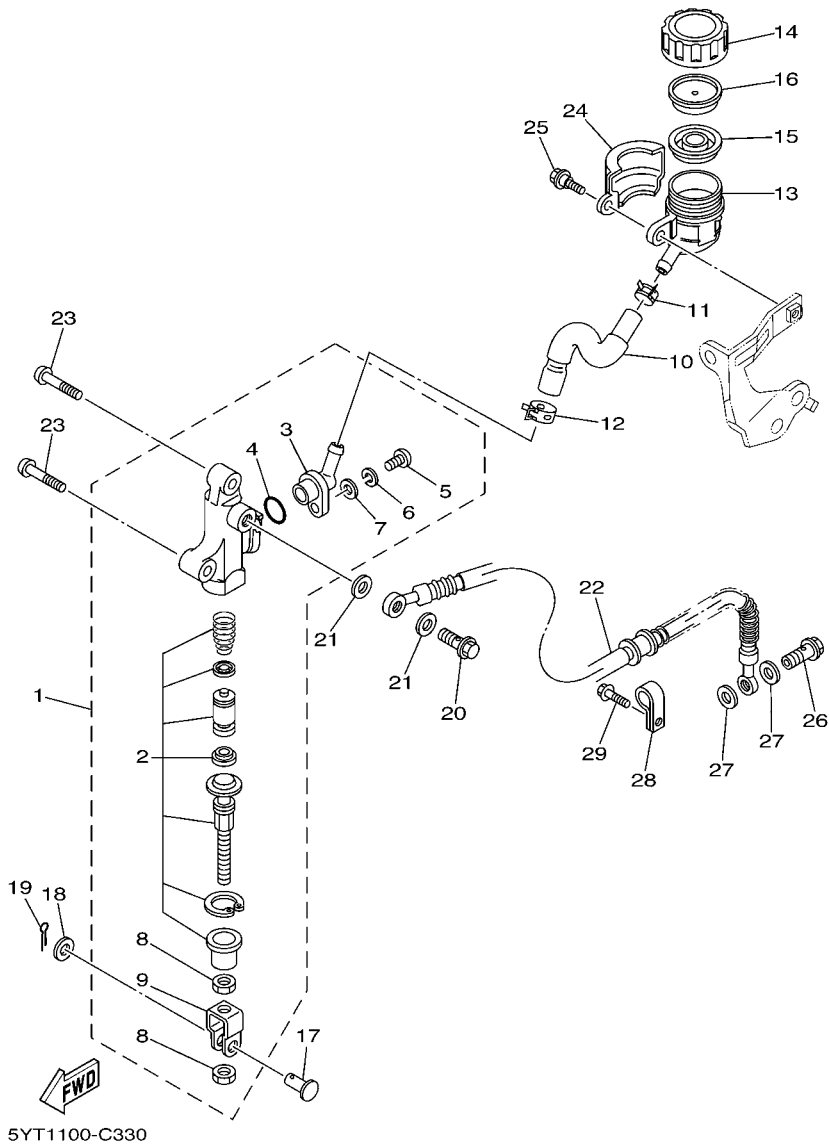
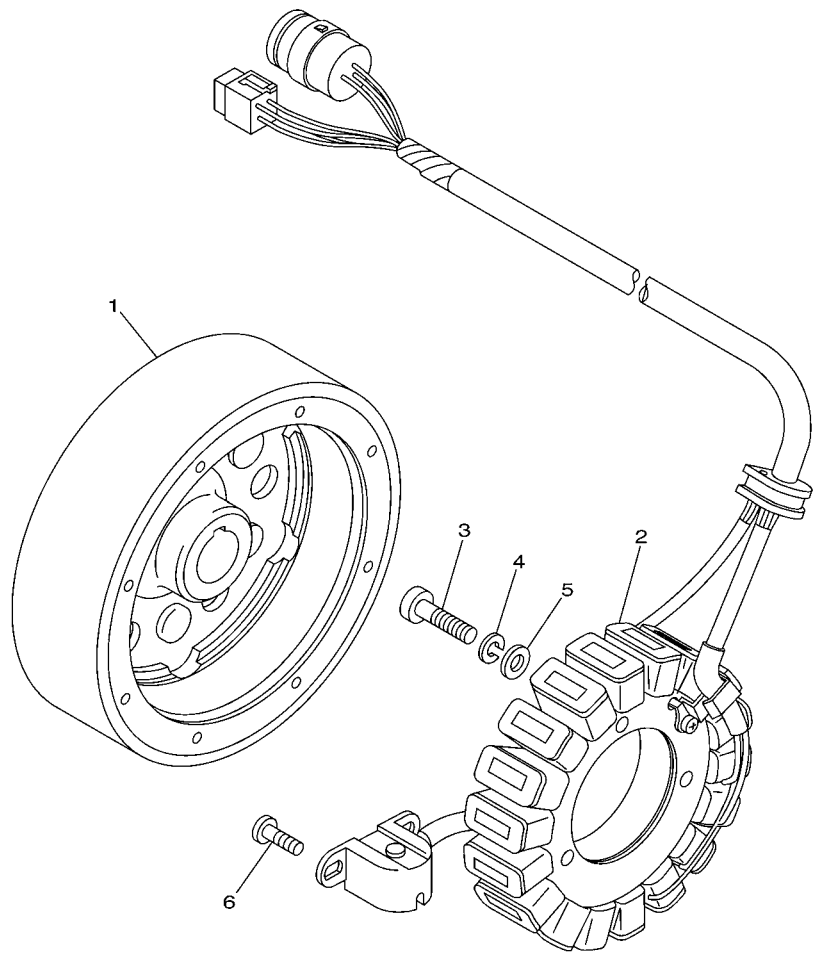

FIG. 33 REAR MASTER CYLINDER

REF. NO.	PART NO.	DESCRIPTION	USA	CAN	EUR	OCE	JPN	REMARKS
28	5YT-25876-10	HOLDER, BRAKE HOSE 2	1	1	1	1	1	
29	95802-06020	BOLT, FLANGE	1	1	1	1	1	

FIG. 35 GENERATOR



REF. NO.	PART NO.	DESCRIPTION	USA	CAN	EUR	OCE	JPN	REMARKS
1	5NF-81450-01	ROTOR ASSY	1	1	1	1	1	
2	5NF-81410-00	STATOR ASSY	1	1	1	1	1	
3	92502-06030	SCREW, PAN HEAD	3	3	3	3	3	
4	92902-06100	WASHER, SPRING	3	3	3	3	3	
5	92902-06600	WASHER, PLATE	3	3	3	3	3	
6	98502-05014	SCREW, PAN HEAD	2	2	2	2	2	

5NF4100-2351

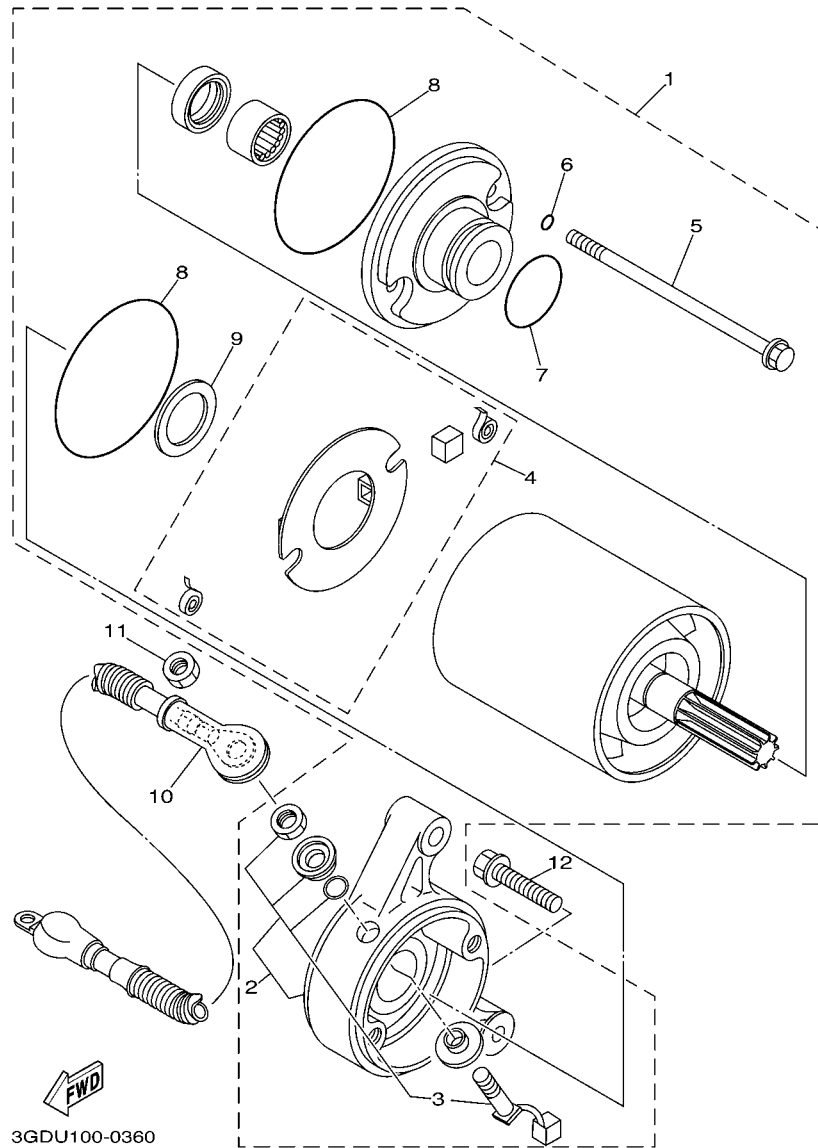
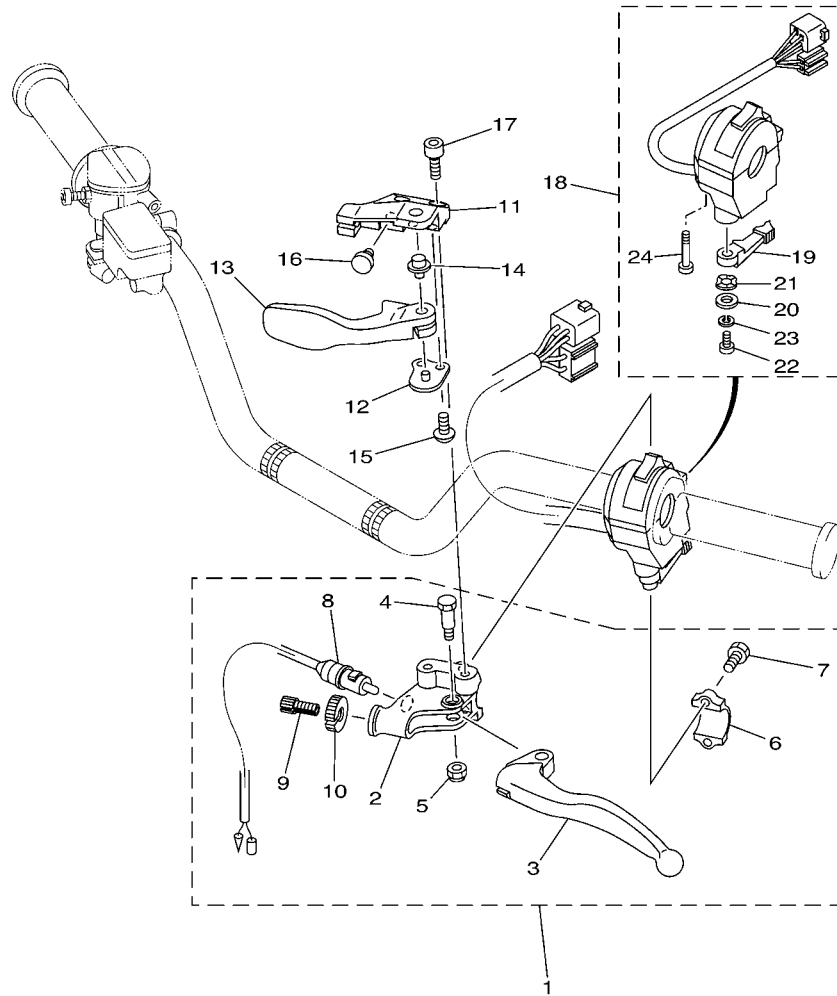

FIG. 36 STARTING MOTOR

REF. NO.	PART NO.	DESCRIPTION	USA	CAN	EUR	OCE	JPN	REMARKS
1	1UY-81890-00	MOTOR ASSY	1	1	1	1	1	
2	1UY-81820-51	.REAR BRACKET ASSY	1	1	1	1	1	
3	1UY-81818-50	..BRUSH AND BOLT	1	1	1	1	1	
4	8L6-81840-50	.BRUSH HOLDER ASSY	1	1	1	1	1	
5	3GD-81826-00	.BOLT, THROUGH	2	2	2	2	2	
6	8L6-81847-50	.O-RING	2	2	2	2	2	
7	1UY-81847-50	.O-RING	1	1	1	1	1	
8	4H7-81844-50	.O-RING	2	2	2	2	2	
9	4H7-81843-50	.WASHER 1	1	1	1	1	1	
10	5YT-81815-00	CORD, STARTER MOTOR	1	1	1	1	1	
11	95302-06600	NUT	1	1	1	1	1	
12	95022-06030	BOLT, FLANGE	2	2	2	2	2	



FWD
5YT1100-C400

FIG. 40 HANDLE SWITCH & LEVER

REF. NO.	PART NO.	DESCRIPTION	USA	CAN	EUR	OCE	JPN	REMARKS
1	5YT-82910-10	LEVER HOLDER ASSY (LEFT)	1	1	1	1	1	
2	5YT-82911-10	.HOLDER, LEVER 1	1	1	1	1	1	
3	2HT-83912-00	.LEVER 1	1	1	1	1	1	
4	90109-06798	.BOLT	1	1	1	1	1	
5	95602-06100	.NUT, U	1	1	1	1	1	
6	5TG-82913-00	.HOLDER, LEVER LOWER 1	1	1	1	1	1	
7	97002-05016	.BOLT	2	2	2	2	2	
8	5KM-82917-00	.SWITCH	1	1	1	1	1	
9	90123-08046	.BOLT	1	1	1	1	1	
10	90179-08148	.NUT	1	1	1	1	1	
11	5TG-25727-00	BRACKET, LEVER	1	1	1	1	1	
12	5D3-25689-00	PLATE, GUIDE	1	1	1	1	1	
13	5TG-25726-00	LEVER, BRAKE	1	1	1	1	1	
14	5TG-83923-00	COLLAR, LEVER 2	1	1	1	1	1	
15	92012-06014	BOLT, BUTTON HEAD	2	2	2	2	2	
16	90338-07007	PLUG	1	1	1	1	1	
17	92012-06014	BOLT, BUTTON HEAD	2	2	2	2	2	
18	5LP-83973-01	SWITCH, HANDLE 3	1	1	1	1	1	
19	5GH-83941-00	.LEVER, STARTER	1	1	1	1	1	
20	1UY-83909-00	.WASHER, SPECIAL	1	1	1	1	1	
21	3L4-83943-00	.WASHER, STARTER	1	1	1	1	1	
22	98517-05012	.SCREW, PAN HEAD	1	1	1	1	1	
23	92907-05100	.WASHER, SPRING	1	1	1	1	1	
24	98507-05030	.SCREW, PAN HEAD	2	2	2	2	2	

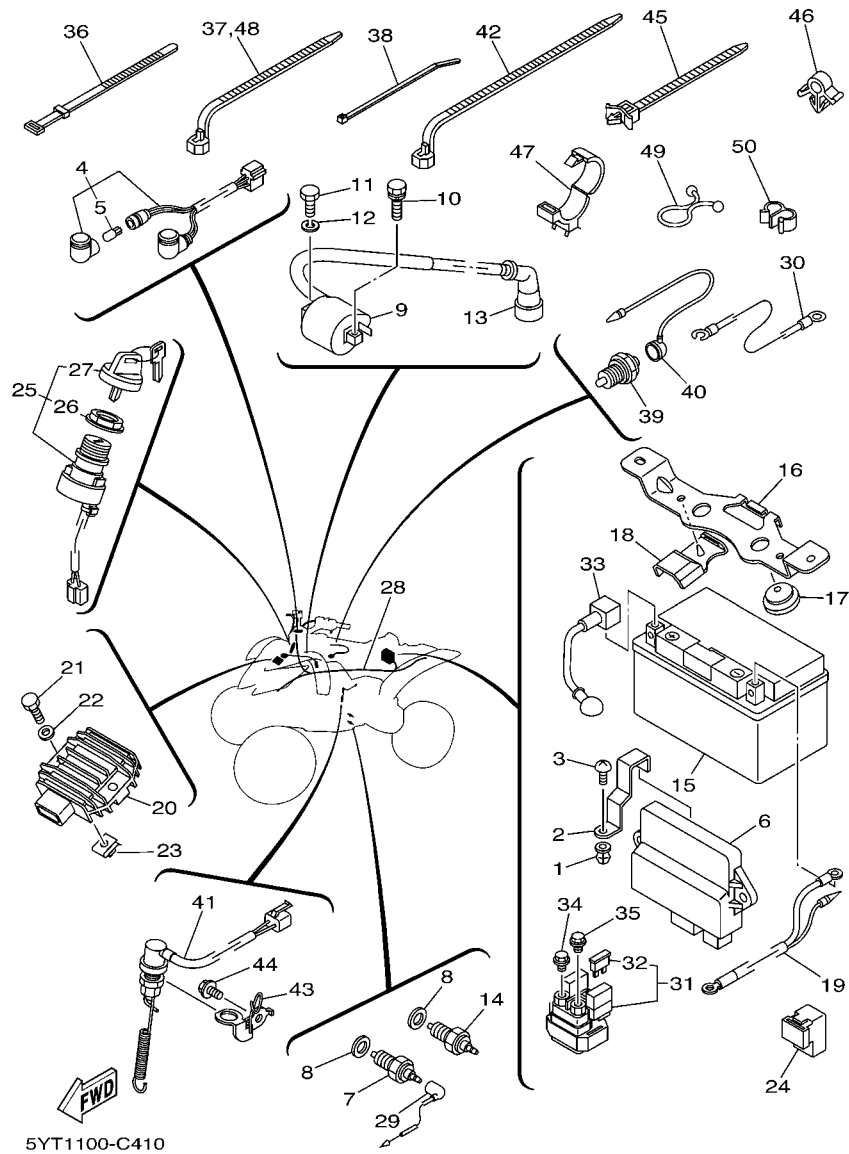

FIG. 41 ELECTRICAL 1

REF. NO.	PART NO.	DESCRIPTION	USA	CAN	EUR	OCE	JPN	REMARKS
1	90338-08226	PLUG	1	1	1	1	1	
2	5YT-8553A-00	STAY UNIT	1	1	1	1	1	
3	97702-60016	SCREW, TAPPING	1	1	1	1	1	
4	5YT-83530-00	PILOT LIGHT ASSY	1	1	1	1	1	
5	5GH-83516-00	.BULB (14V-1.7W)	2	2	2	2	2	
6	5YT-85540-00	C.D.I. UNIT ASSY	1	1	1	1	1	
7	3GB-82540-01	NEUTRAL SWITCH ASSY	1	1	1	1	1	
8	90430-10148	GASKET	2	2	2	2	2	
9	3KJ-82310-10	IGNITION COIL ASSY	1	1	1	1	1	
10	90109-06723	BOLT	1	1	1	1	1	
11	97002-06020	BOLT	1	1	1	1	1	
12	92902-06100	WASHER, SPRING	1	1	1	1	1	
13	1UY-82370-20	PLUG CAP ASSY	1	1	1	1	1	
14	3GD-82540-11	NEUTRAL SWITCH ASSY	1	1	1	1	1	
15	5VY-82100-00	BATTERY ASSY (YUASA YTZ10S)	1	1	1	1	1	
	90793-26097	BATTERY ASSY (YUASA YTZ10S)					1	
16	5YT-82128-00	BRACKET, BATTERY	1	1	1	1	1	
17	371-82121-00	PAD, BATTERY	2	2	2	2	2	
18	5YT-82129-00	COVER, BATTERY	1	1	1	1	1	
19	5YT-82116-00	WIRE, MINUS LEAD	1	1	1	1	1	
20	5GT-81960-00	RECTIFIER & REGULATOR ASSY	1	1	1	1	1	
21	97002-06025	BOLT	1	1	1	1	1	
22	92902-06600	WASHER, PLATE	1	1	1	1	1	
23	90183-061A1	NUT, SPRING	1	1	1	1	1	
24	3GD-81950-01	RELAY ASSY	1	1	1	1	1	
25	5LP-82510-00	MAIN SWITCH ASSY	1	1	1	1	1	
26	3HN-82569-00	.NUT, MAIN SWITCH	1	1	1	1	1	

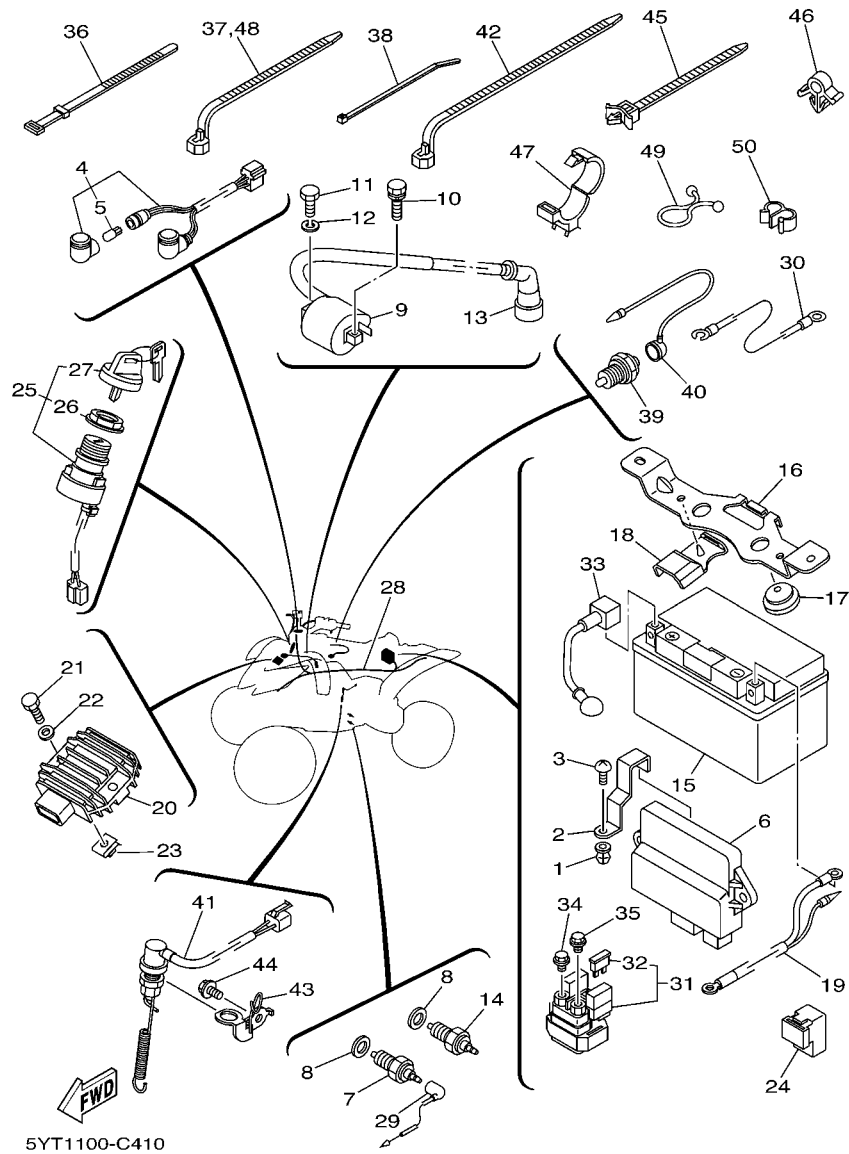

FIG. 41 ELECTRICAL 1

REF. NO.	PART NO.	DESCRIPTION	USA	CAN	EUR	OCE	JPN	REMARKS
27	3HN-82579-00	.CAP, KEY	1	1	1	1	1	
28	5YT-82590-00	WIRE HARNESS ASSY	1	1	1	1	1	
29	5YT-82541-00	WIRE, LEAD	1	1	1	1	1	
30	3GD-82509-10	WIRE, SUB LEAD	1	1	1	1	1	
31	1D0-81940-02	STARTER RELAY ASSY	1	1	1	1	1	
32	36Y-82151-00	.FUSE (15A-BL)	2	2	2	2	2	
33	5YT-82115-00	WIRE, PLUS LEAD	1	1	1	1	1	
34	95022-06008	BOLT, FLANGE	1	1	1	1	1	
35	95022-06008	BOLT, FLANGE	1	1	1	1	1	
36	437-83936-01	BAND, SWITCH CORD	4	4	4	4	4	
37	90464-13073	CLAMP	1	1	1	1	1	
38	90465-10098	CLAMP	1	1	1	1	1	
39	4KD-82540-00	NEUTRAL SWITCH ASSY	1	1	1	1	1	
40	5YT-82507-00	WIRE, LEAD	1	1	1	1	1	
41	5NF-82530-00	STOP SWITCH ASSY	1	1	1	1	1	
42	90464-15195	CLAMP	2	2	2	2	2	
43	5YT-2144G-10	STAY, STOP SWITCH	1	1	1	1	1	
44	95802-06010	BOLT, FLANGE	1	1	1	1	1	
45	90464-12089	CLAMP	3	3	3	3	3	
46	90464-15157	CLAMP	1	1	1	1	1	
47	90464-30252	CLAMP	1	1	1	1	1	
48	90464-13073	CLAMP	1	1	1	1	1	
49	90465-18147	CLAMP	1	1	1	1	1	
50	90468-15139	CLIP	1	1	1	1	1	

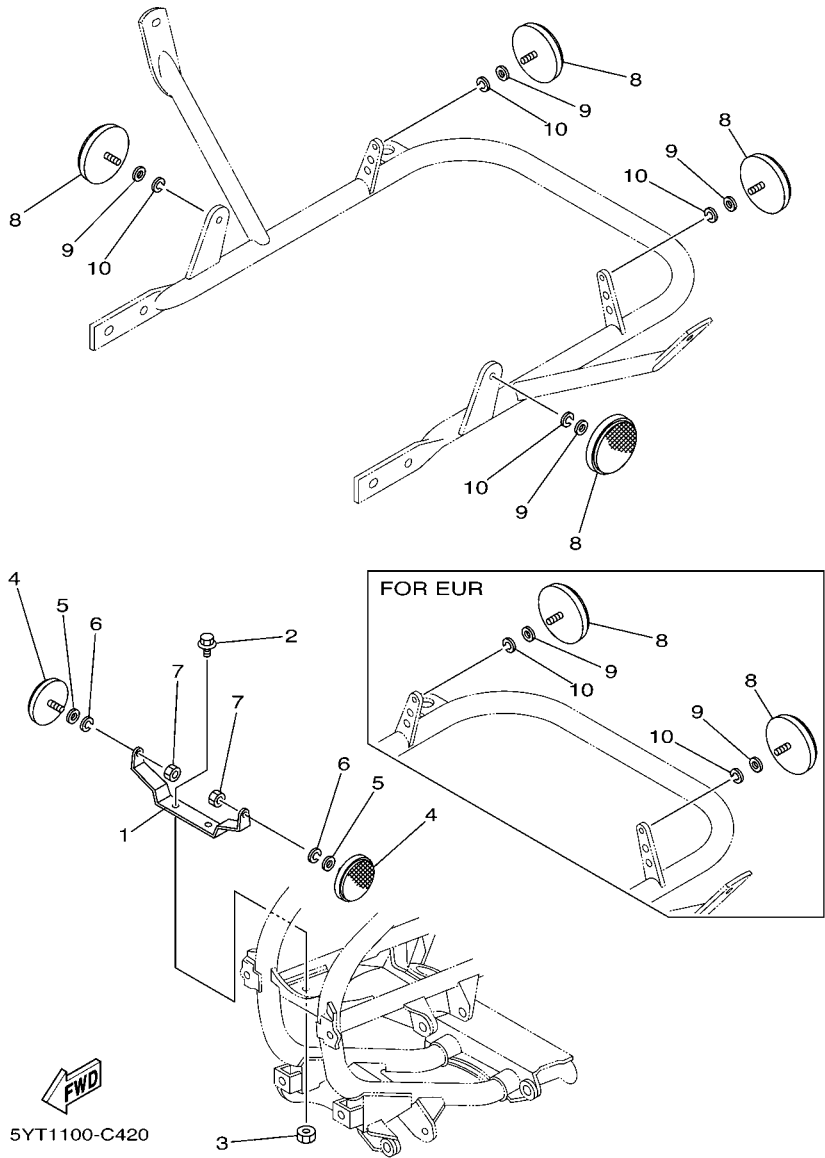

FIG. 42 ELECTRICAL 2

REF. NO.	PART NO.	DESCRIPTION	USA	CAN	EUR	OCE	JPN	REMARKS
1	5YT-85112-10	BRACKET, REFLECTOR 1			1			
2	90119-05062	BOLT, WITH WASHER			2			
3	95302-05600	NUT			2			
4	2EK-85111-00	REFLECTOR, FRONT 1			2			
5	92902-05200	WASHER			2			
6	92902-05100	WASHER, SPRING			2			
7	95302-05600	NUT			2			
8	449-85131-02	REFLECTOR, REAR 1			4	2		
9	92902-05200	WASHER			4	2		
10	92902-05100	WASHER, SPRING			4	2		

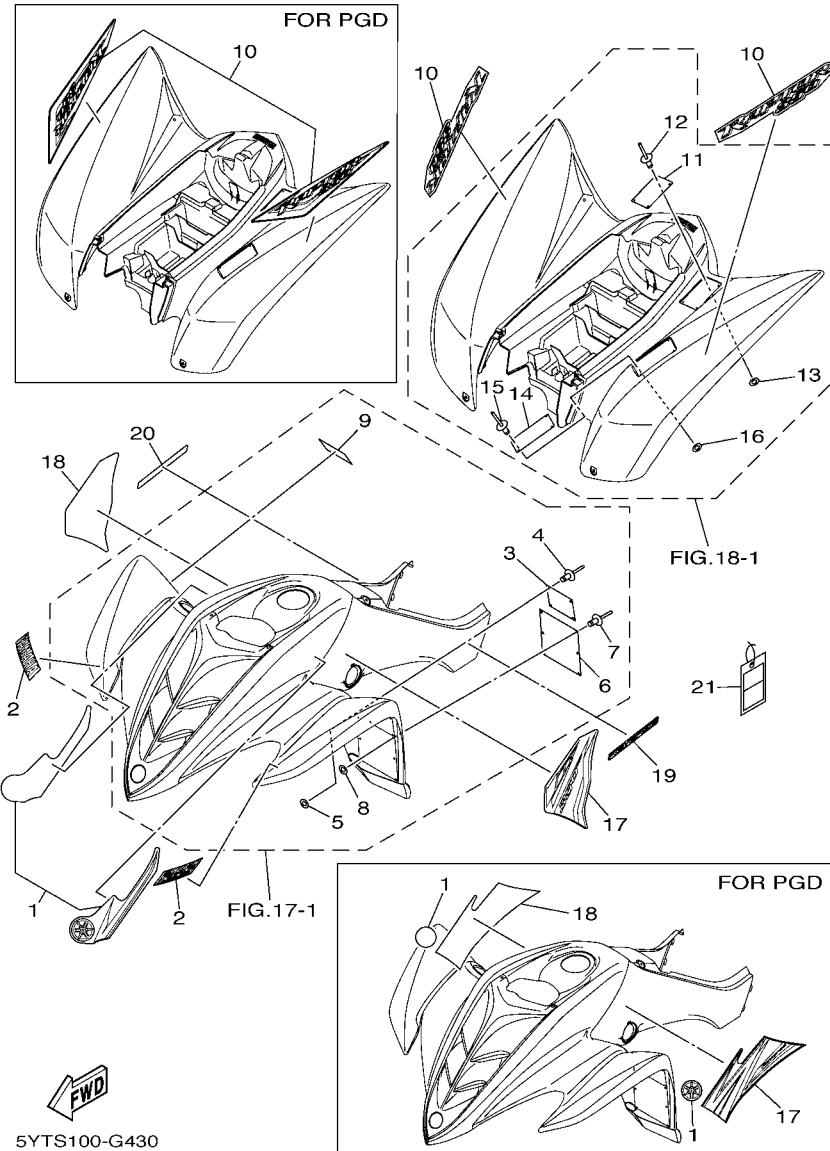

FIG. 43 EMBLEM & LABEL 1

REF. NO.	PART NO.	DESCRIPTION	USA	CAN	EUR	OCE	JPN	REMARKS
1	5YT-21570-50	GRAPHIC SET, FRONT FENDER	1					UR FOR DPBSE
	5FK-2175C-00	TUNING FORK MARK	2					UR FOR PGD
2	4ES-2153E-01	EMBLEM, YAMAHA	2					UR FOR DPBSE
	4ES-2153E-30	EMBLEM, YAMAHA	2					UR FOR PGD
3	5FE-21697-01	LABEL, CAUTION 2	1					ENGLISH
4	90267-32004	RIVET, BLIND	4					
5	90201-03008	WASHER, PLATE	4					
6	5FE-21568-01	LABEL, WARNING	1					ENGLISH
7	90267-32004	RIVET, BLIND	6					
8	90201-03008	WASHER, PLATE	6					
9	5YT-2151E-30	LABEL 2	1					ENGLISH
10	5YT-21609-40	EMBLEM	2					UR FOR DPBSE
	5YT-2165B-90	GRAPHIC SET, REAR FENDER	1					UR FOR PGD
11	5FE-2151H-01	LABEL 5	1					ENGLISH
12	90267-32004	RIVET, BLIND	4					
13	90201-03008	WASHER, PLATE	4					
14	3GD-21696-31	LABEL, CAUTION	1					ENGLISH
15	90267-32004	RIVET, BLIND	4					
16	90201-03008	WASHER, PLATE	4					
17	5YT-2173E-G0	GRAPHIC 1	1					UR FOR DPBSE
	5YT-2173E-H0	GRAPHIC 1	1					UR FOR PGD
18	5YT-2173F-G0	GRAPHIC 2	1					UR FOR DPBSE
	5YT-2173F-H0	GRAPHIC 2	1					UR FOR PGD
19	5YT-21784-30	EMBLEM 4	1					FOR DPBSE
20	5YT-21784-30	EMBLEM 4	1					FOR DPBSE
21	5LP-2819R-00	TAG, WARNING	1					

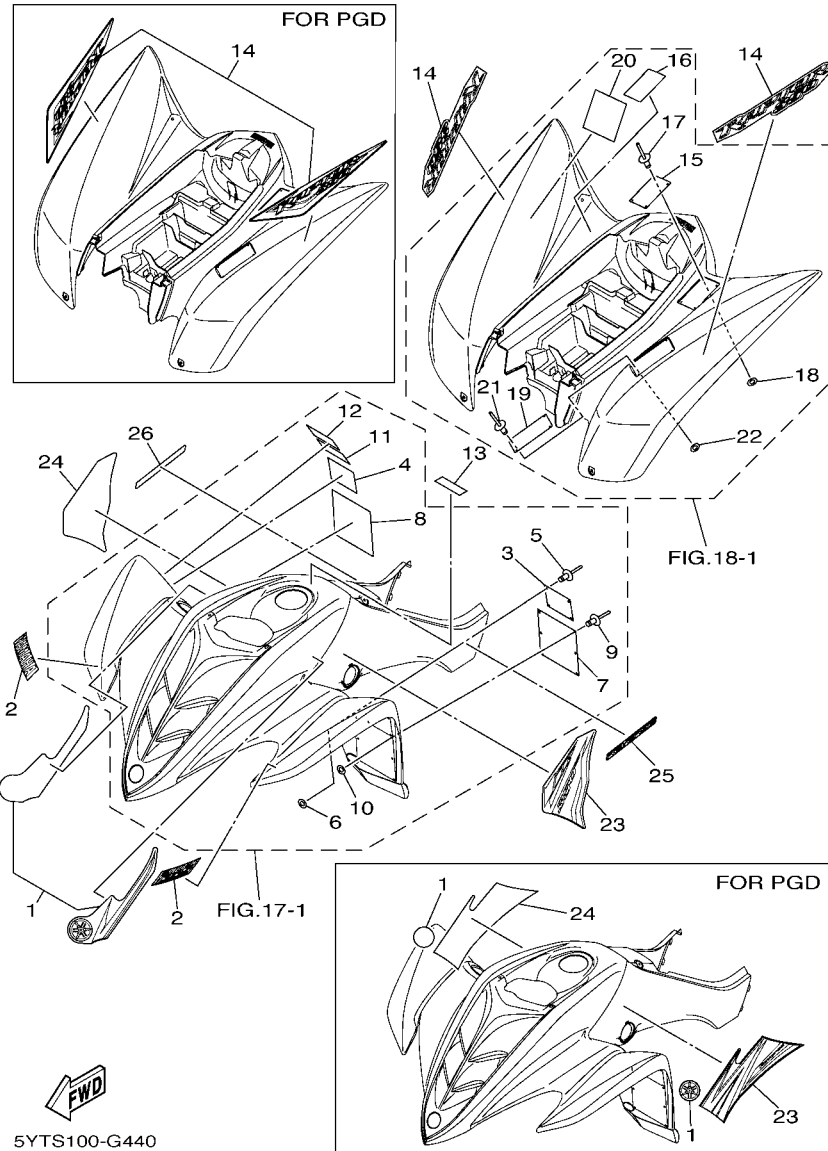

FIG. 44 EMBLEM & LABEL 2

REF. NO.	PART NO.	DESCRIPTION	USA	CAN	EUR	OCE	JPN	REMARKS
1	5YT-21570-50	GRAPHIC SET, FRONT FENDER		1				UR FOR DPBSE
	5FK-2175C-00	TUNING FORK MARK		2				UR FOR PGD
2	4ES-2153E-01	EMBLEM, YAMAHA		2				UR FOR DPBSE
	4ES-2153E-30	EMBLEM, YAMAHA		2				UR FOR PGD
3	5FE-21697-01	LABEL, CAUTION 2		1				ENGLISH
4	3JM-21697-10	LABEL, CAUTION 2		1				FRENCH
5	90267-32004	RIVET, BLIND		4				
6	90201-03008	WASHER, PLATE		4				
7	5FE-21568-01	LABEL, WARNING		1				ENGLISH
8	4WU-21568-10	LABEL, WARNING		1				FRENCH
9	90267-32004	RIVET, BLIND		6				
10	90201-03008	WASHER, PLATE		6				
11	5YT-2151E-30	LABEL 2		1				ENGLISH
12	5YT-2151E-40	LABEL 2		1				FRENCH
13	4SH-2416E-00	LABEL, CAUTION CANADA		1				ENGLISH
14	5YT-21609-40	EMBLEM		2				UR FOR DPBSE
	5YT-2165B-90	GRAPHIC SET, REAR FENDER		1				UR FOR PGD
15	5FE-2151H-01	LABEL 5		1				ENGLISH
16	4WU-2151H-10	LABEL 5		1				FRENCH
17	90267-32004	RIVET, BLIND		4				
18	90201-03008	WASHER, PLATE		4				
19	3GD-21696-31	LABEL, CAUTION		1				ENGLISH
20	3GD-21696-B0	LABEL, CAUTION		1				FRENCH
21	90267-32004	RIVET, BLIND		4				
22	90201-03008	WASHER, PLATE		4				
23	5YT-2173E-G0	GRAPHIC 1		1				UR FOR DPBSE
	5YT-2173E-H0	GRAPHIC 1		1				UR FOR PGD

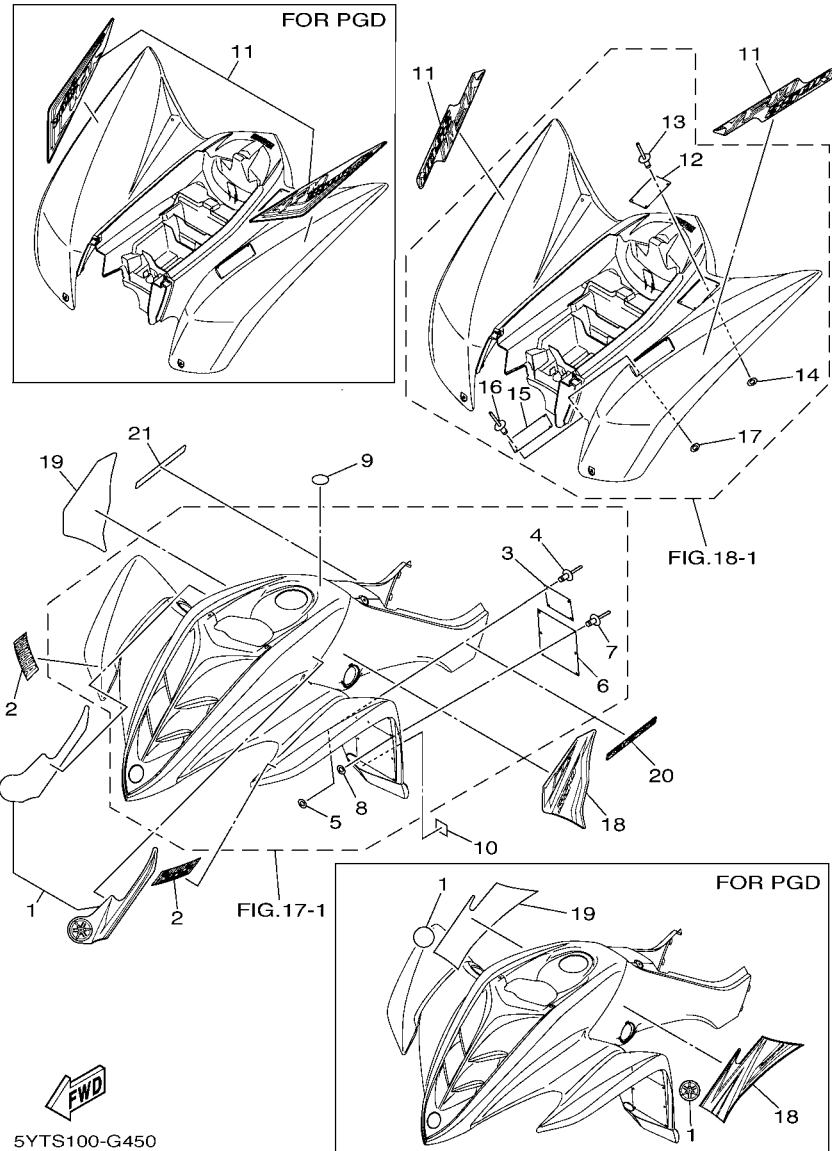

FIG. 45 EMBLEM & LABEL 3

REF. NO.	PART NO.	DESCRIPTION	USA	CAN	EUR	OCE	JPN	REMARKS
1	5YT-21570-50	GRAPHIC SET, FRONT FENDER			1			UR FOR DPBSE
	5FK-2175C-00	TUNING FORK MARK			2			UR FOR PGD
2	4ES-2153E-01	EMBLEM, YAMAHA			2			UR FOR DPBSE
	4ES-2153E-30	EMBLEM, YAMAHA			2			UR FOR PGD
3	5FK-21697-00	LABEL, CAUTION 2			1			
4	90267-32004	RIVET, BLIND			4			
5	90201-03008	WASHER, PLATE			4			
6	5FK-21568-00	LABEL, WARNING			1			
7	90267-32004	RIVET, BLIND			6			
8	90201-03008	WASHER, PLATE			6			
9	3ME-2415E-01	LABEL, CAUTION			1			
10	4GB-2155A-00	MARK, EC			1			
11	5YT-21609-50	EMBLEM			2			UR FOR DPBSE
	5YT-2165B-A0	GRAPHIC SET, REAR FENDER			1			UR FOR PGD
12	5FK-2151H-00	LABEL 5			1			
13	90267-32004	RIVET, BLIND			4			
14	90201-03008	WASHER, PLATE			4			
15	5NF-21696-M0	LABEL, CAUTION			1			
16	90267-32004	RIVET, BLIND			4			
17	90201-03008	WASHER, PLATE			4			
18	5YT-2173E-G0	GRAPHIC 1			1			UR FOR DPBSE
	5YT-2173E-H0	GRAPHIC 1			1			UR FOR PGD
19	5YT-2173F-G0	GRAPHIC 2			1			UR FOR DPBSE
	5YT-2173F-H0	GRAPHIC 2			1			UR FOR PGD
20	5YT-21784-30	EMBLEM 4			1			FOR DPBSE
21	5YT-21784-30	EMBLEM 4			1			FOR DPBSE

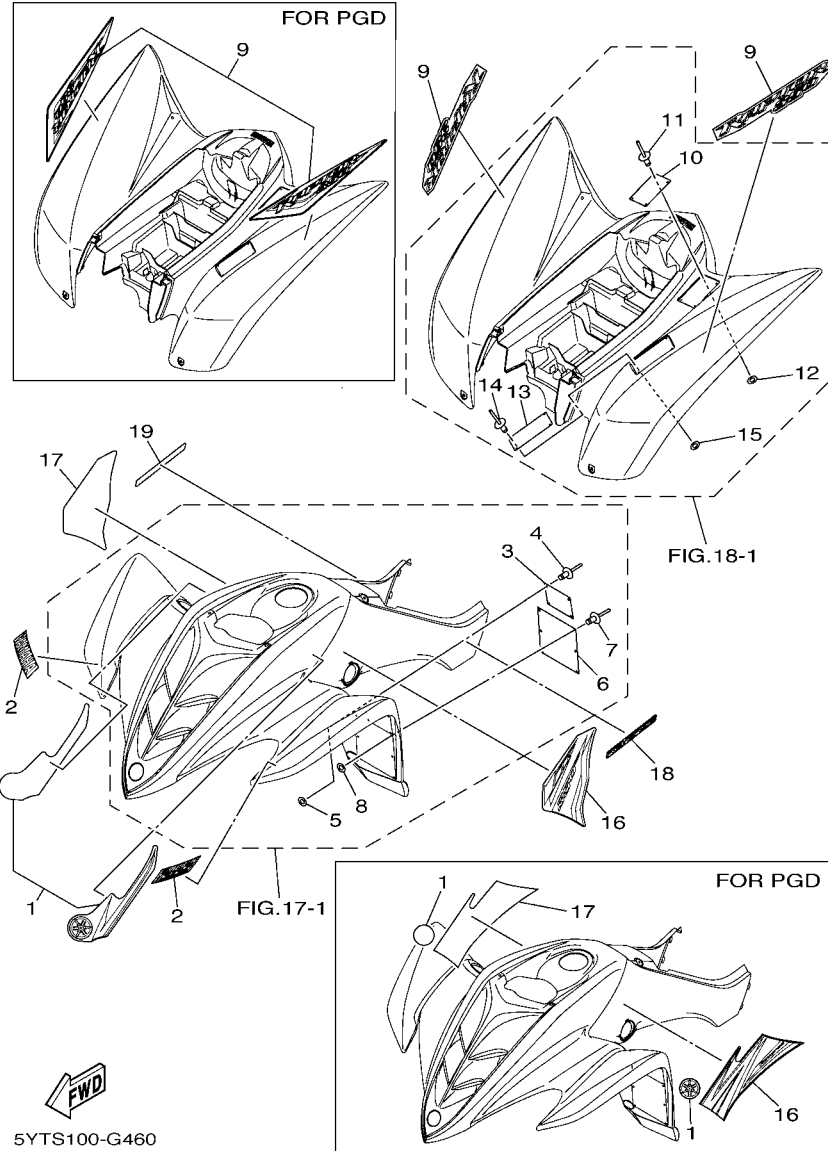
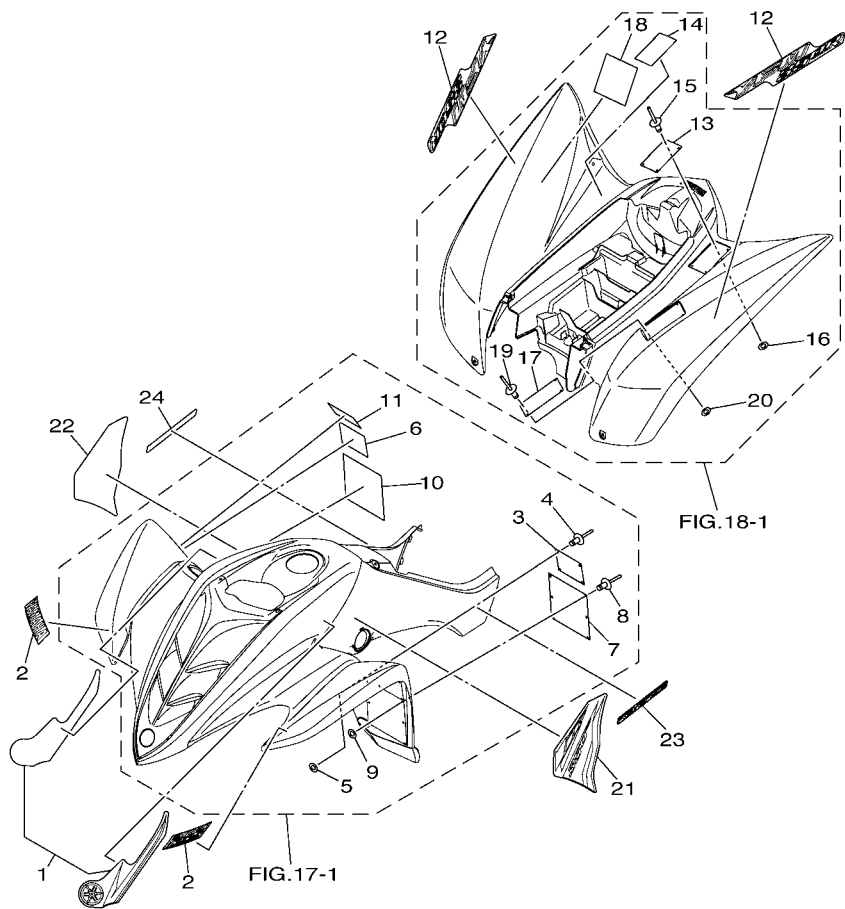

FIG. 46 EMBLEM & LABEL 4

REF. NO.	PART NO.	DESCRIPTION	USA	CAN	EUR	OCE	JPN	REMARKS
1	5YT-21570-50	GRAPHIC SET, FRONT FENDER					1	UR FOR DPBSE
	5FK-2175C-00	TUNING FORK MARK					2	UR FOR PGD
2	4ES-2153E-01	EMBLEM, YAMAHA					2	UR FOR DPBSE
	4ES-2153E-30	EMBLEM, YAMAHA					2	UR FOR PGD
3	5FE-21697-01	LABEL, CAUTION 2					1	ENGLISH
4	90267-32004	RIVET, BLIND					4	
5	90201-03008	WASHER, PLATE					4	
6	5FE-21568-11	LABEL, WARNING					1	ENGLISH
7	90267-32004	RIVET, BLIND					6	
8	90201-03008	WASHER, PLATE					6	
9	5YT-21609-40	EMBLEM					2	UR FOR DPBSE
	5YT-2165B-90	GRAPHIC SET, REAR FENDER					1	UR FOR PGD
10	5FE-2151H-01	LABEL 5					1	ENGLISH
11	90267-32004	RIVET, BLIND					4	
12	90201-03008	WASHER, PLATE					4	
13	3GD-21696-31	LABEL, CAUTION					1	ENGLISH
14	90267-32004	RIVET, BLIND					4	
15	90201-03008	WASHER, PLATE					4	
16	5YT-2173E-G0	GRAPHIC 1					1	UR FOR DPBSE
	5YT-2173E-H0	GRAPHIC 1					1	UR FOR PGD
17	5YT-2173F-G0	GRAPHIC 2					1	UR FOR DPBSE
	5YT-2173F-H0	GRAPHIC 2					1	UR FOR PGD
18	5YT-21784-30	EMBLEM 4					1	FOR DPBSE
19	5YT-21784-30	EMBLEM 4					1	FOR DPBSE



5YTS100-G470

FIG. 47 EMBLEM & LABEL 5

REF. NO.	PART NO.	DESCRIPTION	USA	CAN	EUR	OCE	JPN	REMARKS
1	5YT-21570-50	GRAPHIC SET, FRONT FENDER					1	UR FOR DPBSE
2	4ES-2153E-01	EMBLEM, YAMAHA					2	UR FOR DPBSE
3	5FE-21697-01	LABEL, CAUTION 2					1	ENGLISH
4	90267-32004	RIVET, BLIND					4	
5	90201-03008	WASHER, PLATE					4	
6	4SH-21697-00	LABEL, CAUTION 2					1	JAPANESE
7	5FE-21568-11	LABEL, WARNING					1	ENGLISH
8	90267-32004	RIVET, BLIND					6	
9	90201-03008	WASHER, PLATE					6	
10	4SH-21568-00	LABEL, WARNING					1	JAPANESE
11	5YT-2151E-50	LABEL 2					1	JAPANESE
12	5YT-21609-50	EMBLEM					2	
13	5FE-2151H-01	LABEL 5					1	ENGLISH
14	4LB-2151H-02	LABEL 5					1	
15	90267-32004	RIVET, BLIND					4	
16	90201-03008	WASHER, PLATE					4	
17	3GD-21696-31	LABEL, CAUTION					1	ENGLISH
18	3GD-21696-C0	LABEL, CAUTION					1	JAPANESE
19	90267-32004	RIVET, BLIND					4	
20	90201-03008	WASHER, PLATE					4	
21	5YT-2173E-G0	GRAPHIC 1					1	UR FOR DPBSE
22	5YT-2173F-G0	GRAPHIC 2					1	UR FOR DPBSE
23	5YT-21784-30	EMBLEM 4					1	FOR DPBSE
24	5YT-21784-30	EMBLEM 4					1	FOR DPBSE

NUMERICAL INDEX

PART NO.	GRID NO.	PART NO.	GRID NO.	PART NO.	GRID NO.	PART NO.	GRID NO.	PART NO.	GRID NO.	PART NO.	GRID NO.
5YT-11101-10	B - 2	3Y1-12231-01	B - 8	1UY-14468-00	B - 10	3J2-16324-00	C - 4	4GB-18531-00	C - 8	5YT-21609-40	F - 3
3Y1-1111F-00	B - 2	1UY-12241-00	B - 8	583-14561-00	B - 11	168-16325-00	C - 4	22U-18535-00	C - 8		F - 4
31G-11127-00	B - 2	1UY-13161-01	B - 9	5DM-14561-00	B - 11	5Y1-16331-01	C - 4	5YT-18540-00	C - 8		F - 7
3Y1-11127-00	B - 2	1UY-13300-00	B - 9	1FN-14565-00	B - 12	5YT-16340-00	C - 4	3GH-18542-00	C - 8	5YT-21609-50	F - 6
3Y1-11133-11	B - 2	1UY-13324-00	B - 9	1UY-14611-02	B - 13	1UY-16351-00	C - 4	5YT-21110-00	C - 10		F - 8
31G-11161-00	B - 2	1UY-13326-00	B - 9	3GD-14613-00	B - 13	1UY-16352-00	C - 4	5YT-21110-10	C - 10	5YT-21613-10	C - 13
5YT-11166-00	B - 14	3GD-13329-00	B - 9	5YT-14628-00	B - 13	1UY-16356-00	C - 5	5YT-2117G-00	C - 10	5YT-21614-10	C - 13
371-11167-01	B - 14	51Y-13411-00	B - 9	5YT-14708-01	B - 13	1UY-16358-00	C - 4	1UY-21315-20	C - 10	5LP-21621-00	C - 13
1UY-11181-01	B - 2	2XK-13416-00	B - 9	5YT-14710-00	B - 13	1UY-16371-02	C - 4	1UY-21316-20	C - 10	5YT-2164F-10	C - 13
5NF-11185-00	B - 2	1UY-13440-02	B - 9	5TG-14752-00	B - 13	1UY-16382-00	C - 4	5YT-2144G-10	E - 15	5YT-2164G-10	C - 13
2NL-11186-12	B - 2	3GD-13447-00	B - 9	4WM-14755-00	B - 13	5Y1-16383-00	C - 4	5YT-21471-00	C - 10	5YT-2164H-10	C - 13
2NL-11187-11	B - 2	5YT-13586-00	B - 10	5YT-14787-00	B - 13	3LD-16398-00	C - 5	5YT-21513-00	C - 12	5YT-2164J-10	C - 13
5YT-11310-00	B - 4	5MP-14105-00	B - 11	5YT-14788-00	B - 13	1UY-17121-00	C - 6	5YT-21514-00	C - 12	5YT-2165B-90	F - 3
4KB-11351-00	B - 4	5YT-1410A-00	B - 11	5YT-14901-00	B - 11	1UY-17123-00	C - 6	5YT-2151E-30	F - 3		F - 4
1UY-11400-00	B - 5	5YT-14112-00	B - 11	5YT-14901-10	B - 11	1UY-17131-00	C - 6		F - 4		F - 7
1UY-11422-00	B - 5	5YT-14123-00	B - 11	5YT-1490H-00	B - 12	1UY-17151-00	C - 6	5YT-2151E-40	F - 4	5YT-2165B-A0	F - 6
1UY-11454-00	B - 6	137-14133-00	B - 12	5YT-1490J-00	B - 11	1UY-17161-01	C - 6	5YT-2151E-50	F - 8	5LP-21621-00	C - 13
30X-11496-00	B - 5	80N-14139-00	B - 12	5YT-1490J-10	B - 11	1UY-17211-00	C - 6	5FK-2151H-00	F - 6	3GD-21696-31	F - 3
3Y1-11531-02	B - 5	5YT-14141-40	B - 11	5GH-14918-00	B - 11	5YT-17221-00	C - 6	5FE-2151H-01	F - 3		F - 4
1UY-11536-01	B - 6	4KM-14142-22	B - 12	5KM-14937-00	B - 12	1UY-17223-02	C - 6		F - 4		F - 7
30X-11565-00	B - 5	354-14147-00	B - 12	8FA-14940-00	B - 11	1UY-17231-01	C - 6		F - 7		F - 8
4GB-11610-00	B - 5	3H1-14147-00	B - 11	3H1-14962-00	B - 11	1UY-17241-00	C - 6		F - 8	3GD-21696-B0	F - 4
4GB-11610-20	B - 5	5LP-14147-00	B - 12	5FU-14962-00	B - 11	1UY-17243-00	C - 7	4LB-2151H-02	F - 8	3GD-21696-C0	F - 8
4GB-11610-40	B - 5	3GD-14155-00	B - 12	5DM-14985-00	B - 12	1UY-17251-00	C - 6	4WU-2151H-10	F - 4	5NF-21696-M0	F - 6
5UH-11631-00-C0	B - 5	522-14161-00	B - 12	28V-14988-00	B - 12	1UY-17253-00	C - 7	4ES-2153E-01	F - 3	4SH-21697-00	F - 8
55V-11633-00	B - 6	127-14186-00	B - 11	3GD-15100-03	B - 14	5YT-17261-00	C - 6		F - 4	5FK-21697-00	F - 6
5UH-11636-00	B - 5	5YT-14190-25	B - 11	30X-15351-00	B - 9	1UY-17285-00	C - 7		F - 6	5FE-21697-01	F - 3
5UH-11638-00	B - 5	5LW-14191-00	B - 12	1UY-15362-01	B - 15	1UY-17401-01	C - 6		F - 7		F - 4
1UY-11651-00	B - 5	24W-14193-00	B - 12	3R4-15381-00	B - 14	1UY-17421-02	C - 6		F - 8		F - 7
30X-11681-00	B - 5	5YT-14193-00	B - 11	1UY-15383-00	B - 14	1UY-17431-00	C - 7	4ES-2153E-30	F - 3		F - 8
1UY-12111-01	B - 7	5YT-14194-00	B - 11	3GD-15411-00	B - 15	1UY-17432-01	C - 6		F - 4	3JM-21697-10	F - 4
1UY-12113-01	B - 7	5YT-14197-00	B - 12	1UY-15421-00	B - 15	1UY-17523-00	C - 7		F - 6	5YT-21711-00	C - 15
1UY-12114-01	B - 7	5YT-14197-10	B - 12	3GD-15431-10	B - 15	1UY-17582-00	C - 7		F - 7	5YT-21711-50	C - 15
3Y1-12116-00	B - 7	5YT-14197-20	B - 12	5YT-15441-10	B - 14	1UY-18101-01	C - 8	5TG-21541-00	D - 8	5YT-21721-00	C - 15
3Y1-12117-01	B - 7	4KM-14216-00	B - 11	3GD-15451-00	B - 15	5YT-18110-10	C - 8	4GB-2155A-00	F - 6	5YT-21721-50	C - 15
1J7-12118-00	B - 7	3G2-14231-14	B - 11	3GD-15461-00	B - 15	1UY-18112-10	C - 9	5YT-21562-00	C - 12	5YT-2173E-G0	F - 3
1UY-12121-01	B - 7	1HX-14231-33	B - 11	1UY-15512-00	C - 3	5YT-18113-00	C - 9	4SH-21568-00	F - 8		F - 4
M01-12129-00	B - 7	3G2-1423A-79	B - 11	1UY-15517-01	C - 3	1JN-18115-00	C - 9	5FK-21568-00	F - 6		F - 6
3GD-12151-11	B - 7	5YT-14261-00	B - 11	1UY-15521-02	C - 3	4G0-18127-00	C - 8	5FE-21568-01	F - 3		F - 7
4SH-12156-00	B - 7	5YT-14411-00	B - 10	1UY-15590-01	C - 3	1UY-18140-00	C - 8		F - 4		F - 8
31G-12158-00	B - 7	5YT-14412-01	B - 10	21V-15719-00	B - 15	2H9-18154-00	C - 9	4WU-21568-10	F - 4	5YT-2173E-H0	F - 3
31G-12159-02	B - 7	5YT-1442F-00	B - 10	3GD-15777-10	C - 3	4SH-18198-00	D - 15	5FE-21568-11	F - 7		F - 4
5UH-12170-10	B - 8	5GH-14436-00	B - 10	3GD-15787-03	B - 15	1UY-18311-00	C - 8		F - 8		F - 6
5YT-12176-00	B - 8	1UY-14451-00	B - 10	1UY-16111-10	C - 4	3GD-18420-00	C - 8	5YT-21570-50	F - 3		F - 7
31G-12210-01	B - 8	4FU-14452-00	B - 10	2NL-16150-00	C - 4	1YW-18511-00	C - 8		F - 4	5YT-2173F-G0	F - 3
3GD-12213-00	B - 8	5YT-14453-00	B - 10	30X-16154-00	C - 4	4GB-18512-00	C - 8		F - 6		F - 5
31G-12214-00	B - 8	59V-14457-00	B - 10	1UY-16181-00	C - 5	1UY-18513-00	C - 8		F - 7		F - 6
31G-12222-00	B - 8	1UY-14458-01	B - 10	31A-16321-01	C - 4	2A6-18531-00	C - 8		F - 8		F - 7

NUMERICAL INDEX

PART NO.	GRID NO.	PART NO.	GRID NO.	PART NO.	GRID NO.	PART NO.	GRID NO.	PART NO.	GRID NO.	PART NO.	GRID NO.
5YT-2173F-G0	F - 8	3GD-23550-20	D - 6	5TG-25438-10	D - 12	5LP-26241-00	D - 15	5YT-82115-00	E - 15	4TR-84723-00	E - 12
5YT-2173F-H0	F - 3	3GD-23570-10	D - 6	5D3-25689-00	E - 13	4KB-26250-20	D - 15	5YT-82116-00	E - 14	4TR-84733-00	E - 11
	F - 5	3GD-23570-20	D - 6	5YT-25712-00	D - 14	4KB-26256-00	D - 15	371-82121-00	E - 14		E - 12
	F - 6	3GD-23580-10	D - 6	5TG-25726-00	E - 13	4KB-26258-00	D - 15	5YT-82128-00	E - 14	5YT-84751-00	E - 12
	F - 7	3GD-23580-20	D - 6	5TG-25727-00	E - 13	1UY-26259-00	E - 3	5YT-82129-00	E - 14	2EK-85111-00	F - 2
5FK-2175C-00	F - 3	1UY-23812-00	D - 5	5LP-2580T-00	D - 11	1NV-2625G-01	D - 15	3TJ-82131-00	C - 11	5YT-85112-10	F - 2
	F - 4	5YT-23813-20	D - 5	5LP-2580U-00	D - 11	4KB-2628F-20	D - 15	36Y-82151-00	E - 15	449-85131-02	F - 2
	F - 6	8K1-23814-00	D - 5	5YT-2580W-00	D - 14	4KB-2628G-00	D - 15	3KJ-82310-10	E - 14	5YT-8553A-00	E - 14
	F - 7	3GD-23831-00	D - 5	3GD-25827-00	D - 11	1NV-26304-00	D - 15	1UY-82370-20	E - 14	5YT-85540-00	E - 14
5UH-2177C-20	B - 10	1UY-23841-01	D - 5	3GD-25828-00	D - 11	5YT-26311-10	D - 15	5YT-82507-00	E - 15	5LP-W0041-00	E - 3
5YT-21784-30	F - 3	1UY-23845-01	D - 5	47X-2582A-50	E - 5	4KB-2632G-00	D - 15	3GD-82509-10	E - 15	5FK-W0042-50	E - 5
	F - 5	5YT-23868-00	D - 5	3GD-2582T-10	D - 11	5YT-26331-00	D - 15	5LP-82510-00	E - 14	5LP-W0045-00	D - 11
	F - 6	2GU-23872-00	C - 10	5TG-2582W-00	D - 14	5YT-26335-10	D - 15	5NF-82530-00	E - 15	5LP-W0046-50	D - 14
	F - 7	1UY-23894-01	D - 5	5MV-25833-00	E - 3	5YT-26341-01	D - 15	4KD-82540-00	E - 15	3GD-W0047-00	D - 11
	F - 8	5YT-24110-00	D - 8	5LP-2583T-01	E - 3	1UY-26372-00	E - 2	3GB-82540-01	E - 14	5LP-W0047-50	D - 14
5YT-2210J-00	D - 2	5YT-24110-10	D - 8	5YT-2583V-00	E - 5	31A-26372-00	D - 15	3GD-82540-11	E - 14	1UY-W0048-50	D - 11
5YT-2210K-00	D - 2	8AC-2414B-01	C - 12	5LP-25852-01	E - 3	1NV-26398-00	D - 15	5YT-82541-00	E - 15		D - 14
3GD-22110-30	D - 2	5YT-2414H-00	D - 8	3XP-25852-50	E - 5	371-27114-00	D - 9	3HN-82569-00	E - 14	3GD-W0057-00	D - 11
2K6-22128-01	D - 2	3ME-2415E-01	F - 6	2VN-25854-00	E - 5	5YT-27211-10	E - 4	3HN-82579-00	E - 15	5LP-W0057-50	D - 14
5YT-22129-00	D - 2	4SH-2416E-00	F - 4	4L0-25854-00	E - 3	4SS-27218-00	E - 5	5YT-82590-00	E - 15	1UY-W1141-00	B - 5
1UY-22141-10	D - 2	1UY-24311-00	D - 8	2VN-25855-00	E - 5	2YK-27222-00	E - 5	5YT-82910-10	E - 13	5YT-W2151-01	C - 12
2GU-22151-00	D - 2	5YT-24311-10	D - 8	2GU-25866-00	E - 3	5YT-27411-10	E - 4	5YT-82911-10	E - 13	5YT-W2151-50	C - 12
3TB-22178-00	C - 10	5YT-24423-00	B - 11	5LP-25867-00	E - 3	5YT-27421-10	E - 4	4V4-82913-00	D - 15	5YT-W215B-00	C - 12
3GD-22184-00	D - 2	21V-24500-11	D - 8	5YT-25871-10	E - 3	2XK-28100-00	C - 10	5TG-82913-00	E - 13	5YT-W215B-50	C - 12
4V4-22184-00	C - 10	4X8-24512-00	D - 8	5YT-25872-10	E - 3	1NV-2811A-01	C - 11	5KM-82917-00	E - 13	5YT-W215C-01	C - 12
38W-22199-00	D - 2	3AC-24523-00	D - 8	5YT-25873-10	E - 3	5LP-2819R-00	F - 3	5GH-83516-00	E - 14	5YT-W215C-50	C - 12
5YT-2219X-00	D - 3	5YT-24524-00	D - 8	5YT-25874-10	E - 5	5GT-2836B-10	D - 15	5YT-83530-00	E - 14	5YT-W215D-00	C - 12
5YT-22210-00	D - 4	3AJ-24534-01	D - 8	5YT-25876-10	E - 6	5YT-2845N-00	E - 7	1UY-83909-00	E - 13	5YT-W215E-00	C - 12
5YT-22210-10	D - 4	5KM-24610-00	D - 8	5VM-25886-10	D - 7	5YT-2845R-60	E - 7	2HT-83912-00	E - 13	5YT-W215E-50	C - 12
5YT-22210-20	D - 4	5YT-24665-00	D - 8	5YT-25888-00	E - 5	5YT-2845R-70	E - 7	5LP-83922-00	E - 3	5YT-W2161-00	C - 13
5YT-22210-30	D - 4	5YT-24710-01	D - 9	4EW-25894-00	E - 5	5YT-2845R-80	E - 7	5TG-83923-00	E - 13	5YT-W2161-50	C - 13
5YT-22210-40	D - 4	214-24724-00	D - 9	5YT-25895-00	E - 5	1UY-81175-01	C - 2	437-83936-01	E - 15	5YT-W216B-00	C - 13
5YT-22210-50	D - 4	509-24724-00	D - 9	5MV-2589F-00	E - 3	5NF-81410-00	E - 8	5GH-83941-00	E - 13	5YT-W216B-50	C - 13
5YT-22210-60	D - 4	5YT-24731-00	D - 9	4NK-2589H-00	E - 3	5NF-81450-01	E - 8	3L4-83943-00	E - 13	5YT-W216C-00	C - 13
4AA-22259-40	D - 4	22W-24741-00	C - 10	1UY-25917-51	D - 14	5YT-81815-00	E - 9	5LP-83973-01	E - 13	5YT-W216C-50	C - 13
4AA-22259-50	D - 4	5YT-24776-10	D - 9	1UY-25924-51	D - 14	1UY-81818-50	E - 9	5LP-83980-00	E - 3	90101-08006	D - 12
4AA-22259-70	D - 4	3GD-25111-20	D - 10	3GD-25933-00	D - 11	1UY-81820-51	E - 9	5TG-84110-03	E - 10	90101-10016	B - 8
4AA-22259-80	D - 4	1UY-25117-00	D - 10	1UY-25933-51	D - 14	3GD-81826-00	E - 9	5TG-84140-01	E - 10	90101-10017	B - 5
5YT-23350-00	D - 7	1S3-25127-00	D - 10	1UY-25972-51	D - 14	8L6-81840-50	E - 9	5TG-84165-01	E - 10	90101-10029	D - 12
5YT-23350-10	D - 7	5YT-2514A-00	D - 11	5YT-25977-50	D - 14	4H7-81843-50	E - 9	5TG-84166-01	E - 10	90101-12012	D - 4
5YT-23391-40	C - 12	5LP-25180-20	D - 10	5YT-26111-10	D - 15	4H7-81844-50	E - 9	5TG-84310-03	E - 10	90101-12032	D - 12
5YT-23391-50	C - 12	5YT-25311-00	D - 12	5YT-26124-00	D - 15	1UY-81847-50	E - 9	4KB-84314-01	E - 10	90105-08161	D - 11
3GD-23501-10	D - 6	5YT-25317-00	D - 12	5YT-26124-20	D - 15	8L6-81847-50	E - 9	5TG-84340-01	E - 10	90105-08182	D - 14
3GD-23502-10	D - 7	5YT-25381-10	D - 13	1NV-26129-00	D - 15	1UY-81890-00	E - 9	5LP-84700-00	E - 11	90105-10131	D - 7
5YT-23517-00	D - 6	1S3-25383-20	D - 12	5YT-26150-20	D - 15	1D0-81940-02	E - 15		E - 12	90105-10135	D - 7
3GD-23540-10	D - 6	5YT-25386-00	D - 12	1UY-26153-00	E - 2	3GD-81950-01	E - 14	256-84714-60	E - 11	90105-10136	B - 2
3GD-23540-20	D - 6	3GD-25388-00	D - 12	1UY-26157-00	E - 2	5GT-81960-00	E - 14		E - 12	90105-10137	B - 2
3GD-23550-10	D - 6	5LP-25390-20	D - 12	3GD-26166-10	E - 2	5VY-82100-00	E - 14	4TR-84723-00	E - 11	90105-10185	C - 10

NUMERICAL INDEX

PART NO.	GRID NO.	PART NO.	GRID NO.	PART NO.	GRID NO.	PART NO.	GRID NO.	PART NO.	GRID NO.	PART NO.	GRID NO.
90105-10211	C - 10	90171-14004	D - 12	90201-14021	D - 12	90387-062E0	C - 13	90468-15139	E - 15	92902-06600	E - 14
90105-10277	C - 10	90179-06668	B - 13	90201-14586	D - 10	90387-063W7	E - 2	90468-16191	D - 5	92902-10100	B - 5
90105-12050	D - 2	90179-08148	E - 13	90201-14691	C - 8	90387-066J1	D - 8	90480-01400	D - 8	92902-10200	D - 10
	D - 4	90179-10024	D - 12	90201-15018	C - 9	90387-07021	D - 8	90480-14102	E - 10		D - 12
90105-12061	D - 2	90179-12009	D - 12		E - 4	90387-07598	E - 10	90480-14555	E - 11	92906-04100	E - 5
90105-14003	C - 8	90179-20255	C - 7	90201-150U6	C - 7	90387-084N8	D - 3		E - 12	92906-04600	E - 5
90109-06172	C - 12	90183-05008	C - 12	90201-16018	D - 2	90387-090R0	D - 5	90480-15005	B - 10	92907-04600	B - 12
90109-06189	C - 8	90183-06069	C - 15	90201-17255	C - 7	90387-101R3	D - 6	90480-18290	D - 8	92907-05100	E - 13
90109-06240	E - 5	90183-061A1	E - 14	90201-203E7	C - 6	90387-12020	D - 4	90501-07629	B - 5	93101-25106	B - 6
90109-06723	E - 14	90185-08017	C - 10	90201-207G6	B - 6	90387-12021	D - 2	90501-10353	C - 8	93102-12224	C - 5
90109-06798	E - 13	90185-10011	C - 10	90201-22793	C - 7	90387-125N8	D - 2	90501-18576	B - 9	93102-14209	C - 8
90109-08082	D - 11		D - 12	90201-244A9	D - 2	90387-127G8	D - 4	90501-22721	B - 5	93102-15212	C - 8
90109-08100	C - 10	90185-10012	D - 7	90201-25291	C - 3	90387-150R1	D - 10	90501-231E9	C - 4	93102-22216	D - 10
	E - 7	90185-10019	D - 5	90201-256E6	C - 6	90387-16547	B - 4	90506-20026	E - 4	93102-25081	C - 10
90109-081F0	D - 14	90185-12007	D - 4	90201-28665	C - 7	90387-176R6	D - 5	90508-16022	C - 4	93102-25099	C - 10
90109-10013	D - 12	90185-16002	D - 2	90206-12001	B - 7	90387-257N4	C - 7	90508-23567	D - 9	93102-28476	B - 15
90110-05201	C - 12	90201-03008	F - 3	90209-18208	C - 6	90401-06001	B - 2	90508-25712	C - 8	93102-35393	C - 7
90110-06134	B - 13		F - 4	90209-33253	B - 5	90401-08004	B - 9	90508-32711	C - 8	93104-09025	D - 15
90110-06189	B - 9		F - 6	90215-06162	B - 2	90401-10015	E - 3	90508-35764	E - 2	93104-17094	C - 6
90113-06055	D - 13		F - 7	90215-08260	C - 8		E - 5	90560-14284	C - 8	93104-20068	C - 6
90114-10006	D - 10		F - 8	90215-16156	C - 4	90430-06014	B - 14	90793-26097	E - 14	93105-26026	D - 10
90114-10013	D - 12	90201-05015	B - 13	90215-16222	C - 4		B - 15	91312-06020	B - 2	93106-46001	D - 12
90116-06041	B - 2	90201-06036	E - 2	90215-16258	C - 4	90430-06192	B - 2		B - 9	93108-35004	D - 2
90119-05062	F - 2	90201-06078	E - 10	90215-16270	B - 6	90430-08119	B - 9	91312-06025	B - 2	93109-08050	E - 2
90119-06152	C - 12		E - 11	90215-21239	C - 7	90430-10148	E - 14	91312-06030	B - 4	93109-20076	D - 2
	C - 13	90201-06085	B - 15	90240-07105	B - 5	90430-14194	C - 8	91312-08025	B - 10	93112-31011	D - 5
90123-08046	E - 13	90201-06089	C - 12	90240-08005	E - 5	90430-14240	B - 2	91312-08050	B - 2	93210-06422	C - 4
90149-06108	D - 8	90201-063F3	D - 2	90267-32004	F - 3	90445-084J1	D - 8	91401-16012	E - 5	93210-07590	C - 8
90149-06306	C - 12		D - 6		F - 4	90445-09M32	E - 11	91401-20020	D - 5	93210-09165	B - 7
	C - 13	90201-08048	B - 13		F - 6		E - 12		D - 6	93210-14369	B - 15
90149-08016	C - 3		C - 14		F - 7	90450-52003	B - 10	91401-30025	D - 10	93210-15414	C - 9
90150-06010	C - 15	90201-08054	C - 10		F - 8	90450-63004	B - 10	91401-30030	D - 12	93210-15620	E - 5
90151-05023	B - 15		D - 3	90269-07076	C - 15	90460-75020	B - 10	91609-40016	E - 2	93210-16290	B - 5
90151-06010	B - 9	90201-08066	E - 5	90280-05013	B - 9	90464-12089	E - 15	91A20-07010	B - 12	93210-17003	B - 8
90154-05013	C - 13	90201-08070	C - 5	90280-05048	B - 5	90464-13073	D - 8	92012-06014	E - 13	93210-18322	B - 4
90154-06014	D - 11	90201-10036	D - 5	90282-05034	B - 6		E - 15	92012-06025	B - 15	93210-19522	B - 15
90154-06061	C - 13	90201-10037	D - 7	90282-07057	C - 4	90464-15157	E - 15	92012-08020	E - 2	93210-22164	C - 7
90159-06029	C - 4	90201-10052	D - 12	90338-07007	E - 13	90464-15195	D - 8	92012-08030	E - 5	93210-35520	B - 9
90170-06023	E - 2	90201-10058	B - 5	90338-08226	B - 10		E - 15	92502-06030	E - 8	93210-44545	B - 10
90170-06228	C - 9	90201-10118	E - 3		E - 14	90464-30252	E - 15	92902-04100	B - 12	93210-54175	B - 9
90170-10010	D - 5		E - 5	90338-18122	C - 10	90465-08045	B - 15	92902-05100	F - 2	93210-57634	B - 2
90170-16326	B - 6	90201-10128	B - 2	90338-23172	C - 10	92902-05200	E - 15	92902-05200	F - 2	93210-86509	B - 4
	C - 4	90201-10591	B - 8	90340-14117	B - 15	90465-18147	E - 15	92902-05600	D - 15	93211-06635	B - 2
90170-16343	C - 4	90201-12032	D - 4	90381-15088	D - 6	90467-10038	D - 8	92902-06100	E - 8	93306-00006	C - 4
90170-33010	D - 13	90201-12033	D - 4	90383-20032	D - 2	90467-11044	E - 5		E - 14	93306-00308	C - 7
90171-10001	D - 5	90201-12045	D - 12	90386-12093	C - 5	90467-140A4	B - 14	92902-06200	B - 13	93306-00431	C - 7
	D - 6	90201-12163	C - 4	90387-06158	E - 11	90467-140A6	E - 5	92902-06600	B - 8	93306-00438	B - 8
90171-14002	D - 10	90201-123K4	C - 3		E - 12	90467-220A1	B - 10		E - 8	93306-00446	D - 10

NUMERICAL INDEX

PART NO.	GRID NO.	PART NO.	GRID NO.	PART NO.	GRID NO.	PART NO.	GRID NO.	PART NO.	GRID NO.	PART NO.	GRID NO.
93306-00502	B - 8	95022-06025	B - 15	97002-05016	E - 13						
93306-00710	D - 12	95022-06030	B - 14	97002-06012	B - 2						
93306-07801	B - 15		B - 15	97002-06020	E - 14						
93306-20231	D - 10		E - 9	97002-06025	E - 14						
93306-20301	C - 6	95022-06040	B - 15	97002-08030	D - 3						
93306-20331	C - 10	95022-06045	B - 15	97012-06020	C - 9						
93306-20401	C - 6	95022-06050	B - 14	97022-06016	B - 8						
93306-20501	C - 7	95022-06060	B - 14	97022-08060	D - 5						
93306-20532	B - 6	95302-05600	F - 2	97702-60016	E - 14						
93306-27202	C - 6	95302-06600	E - 9	97702-60025	B - 10						
93306-30424	C - 6		E - 11	97706-40620	E - 11						
93306-30622	B - 5		E - 12		E - 12						
93310-212L6	C - 3	95302-06700	C - 9	98501-04014	B - 12						
93310-225N0	C - 3	95302-08600	D - 12	98502-04008	E - 2						
93310-633T5	B - 5	95302-10700	D - 5	98502-05014	E - 8						
93311-41587	C - 7	95317-06700	E - 2	98502-05020	D - 15						
93317-22237	D - 2	95602-06100	E - 13	98502-06012	B - 14						
93410-20038	C - 6	95602-06200	C - 12		C - 2						
93410-22039	C - 6		C - 13	98506-04012	E - 5						
93430-12008	C - 9	95602-08200	C - 14	98507-03008	D - 8						
	E - 4	95602-12200	D - 2	98507-04006	B - 12						
93440-12052	B - 2		D - 4	98507-04008	B - 12						
93440-25084	C - 6	95604-06100	E - 3	98507-04010	B - 11						
93440-28062	C - 7	95607-05100	D - 15	98507-04012	B - 12						
93450-19095	B - 6	95702-08500	D - 3	98507-05030	E - 13						
93503-08007	C - 8	95702-10500	D - 10	98517-05012	E - 13						
93602-13177	B - 5		D - 12	98702-06016	B - 14						
93603-07073	B - 9	95802-06010	E - 15	98702-06030	B - 9						
93603-12030	B - 9	95802-06020	E - 6	98902-06010	B - 13						
93604-10011	B - 8	95802-06025	E - 10	99001-07600	C - 5						
93605-10090	B - 5	95802-06030	D - 8	99001-09600	C - 4						
93700-06004	D - 2	95802-08040	D - 2	99009-12400	C - 3						
	D - 6	95802-08045	B - 14	99530-12016	B - 14						
93834-13030	C - 7	95812-06014	C - 12		B - 15						
93900-00022	D - 10	95812-06035	E - 2	99530-14016	B - 2						
	D - 12	95812-08012	C - 10		B - 4						
94107-10020	D - 10	95812-08016	B - 13								
94110-09020	D - 12		E - 7								
94500-02090	B - 8	95812-08055	C - 10								
94581-87098	D - 13	95812-10025	E - 4								
94681-87011	D - 13	95822-06010	C - 12								
94701-00333	B - 2	95822-06016	D - 7								
94703-00333	B - 3	95822-06025	E - 3								
95022-06008	B - 13	95822-08012	C - 10								
	E - 15		C - 13								
95022-06016	B - 15	95822-08020	C - 14								
95022-06020	B - 15	95822-08025	C - 14								
95022-06025	B - 8	95822-08030	D - 5								