



PARTS CATALOGUE

YFM35FGB (1NS1) U.S.A.



1L1NS-110E1

()

YFM35FGB
PARTS CATALOGUE
©2011 by Yamaha Motor Co., Ltd.
1st edition, August 2011
All rights reserved.
Any reprinting or unauthorized use
without the written permission of
Yamaha Motor Co., Ltd.
is expressly prohibited.
Printed in Japan.

FOREWORD

This Parts Catalogue is related to the parts for the model(s) on the cover page. When you are ordering replacement parts, please refer to this Parts Catalogue and quote both part numbers and part names correctly.

1. Modifications or additions which have been made after the issue of the Parts Catalogue will be announced in the Parts News.

It is advisable that you make the necessary corrections to the Parts Catalogue according to the Parts News.

2. Abbreviations

The following abbreviations are used in this Parts Catalogue.

“UR” Use specified parts number.

“UN” Use as many as needed.

“AP” Alternate Parts

“LM” Locally Made (Parts need to be ordered locally)

“F#” Frame No. (Applicable machine No.)

“O/S” Over Size

3. The number of components for assembly

- Parts, which are to be supplied in an assembly, are listed with a dot (.) in front of the part name as shown below.
- The numeral appearing to the right of each component part indicates the quantity of parts for each assembly unit.

PART NO.	DESCRIPTION	Q'TY	REMARKS
2F5-83310-60	FRONT FLASHER LIGHT ASSY	2	
115-83311-60	.BULB (6V-18W)	1	

4. Applicable colours of graphics are represented in the “REMARKS” as shown below.

PART NO.	DESCRIPTION	Q'TY	REMARKS
2N4-24110-00-X5	FUEL TANK COMP.	2	MXR
3J1-24240-10	.GRAPHIC, FUEL TANK	1	FOR MXR

5. Note that the illustrations for reference in finding parts numbers are not to be used for assembling. When assembling, please use the applicable service manual.

6. The asterisk (*) before a reference number indicates modified items after the first edition.

FOREWORD

7. Applicable Serial No.

Engine Serial No.

Frame Serial No.

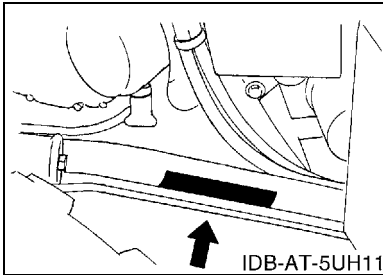
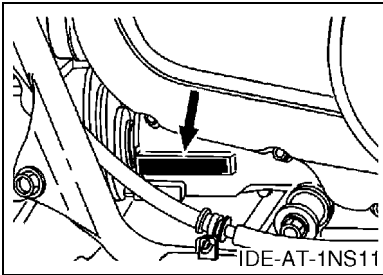

8. Applicable Colour Code (The (*) mark shows Model colour.)

Abbreviation	Colour Name	Colour Code
DPBSN(*)	DARK PURPLISH BLUE SOLID N	0891
PDG(*)	PASTEL DEEP GREEN	00K0

9. Quantity Column Information

Column No.	Name Of Q'ty Column	Destination
1	USA	U.S.A.

CONTENTS

ENGINE

CYLINDER HEAD	1
CYLINDER	3
CRANKSHAFT & PISTON	4
VALVE	6
CAMSHAFT & CHAIN	7
OIL PUMP	8
INTAKE	9
CARBURETOR	10
EXHAUST	12
CRANKCASE	13
CRANKCASE COVER 1	14
STARTER CLUTCH	16
CLUTCH	17
TRANSMISSION	19
MIDDLE DRIVE GEAR	20
SHIFT SHAFT	22

CHASSIS

FRAME	24
FRONT FENDER	25
REAR FENDER	26
SIDE COVER	27
REAR ARM	28
DRIVE SHAFT	29
FRONT DIFFERENTIAL	32
REAR SUSPENSION	34
FRONT SUSPENSION & WHEEL	35
STEERING	36
FUEL TANK	37
SEAT	38
FRONT WHEEL	39
FRONT BRAKE CALIPER	42
REAR WHEEL	44
STEERING HANDLE & CABLE	46
FRONT MASTER CYLINDER	48
STAND & FOOTREST	49
GUARD	50
GENERATOR	51
STARTING MOTOR	52
METER	53
HEADLIGHT	54

TAILLIGHT	55
HANDLE SWITCH & LEVER	56
ELECTRICAL 1	57
GRAPHICS	60
EMBLEM & LABEL 1	61

ALTERNATE PARTS

ALTERNATE FOR ENGINE	62
ALTERNATE FOR METER	63

INDEX

NUMERICAL INDEX	65
-----------------------	----

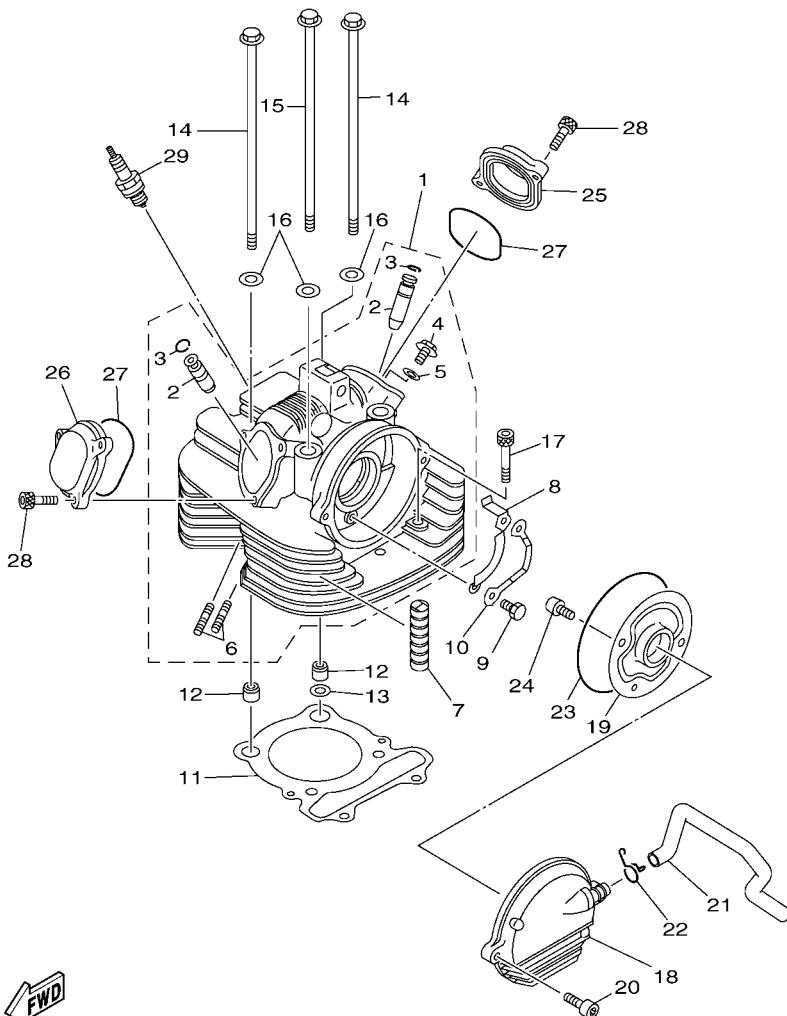

FWD
1NS1110-L010

FIG. 1 CYLINDER HEAD

REF. NO.	PART NO.	DESCRIPTION	USA				REMARKS
1	5YT-11101-20	CYLINDER HEAD ASSY	1				
2	3Y1-11133-11	.GUIDE, VALVE 1	2				
3	93440-12052	.CIRCLIP	2				
4	95022-06014	.BOLT, FLANGE	1				
5	90430-06192	.GASKET	1				
6	90116-06041	.BOLT, STUD	2				
7	3Y1-11127-00	ABSORBER 3	2				
8	3Y1-1111F-00	PLATE	1				
9	97002-06012	BOLT	2				
10	90215-06162	WASHER, LOCK	1				
11	1UY-11181-01	GASKET, CYLINDER HEAD 1	1				
12	99530-14016	PIN, DOWEL	2				
13	90430-14240	GASKET	1				
14	90105-10137	BOLT, FLANGE	2				
15	90105-10136	BOLT, FLANGE	2				
16	90201-10128	WASHER, PLATE	4				
17	91312-08050	BOLT	2				
18	4WU-11160-01	BREATHER ASSY	1				
19	4KB-11165-00	PLATE, BREATHER	1				
20	95022-06012	BOLT, FLANGE	2				
21	3C2-E1166-00	PIPE, BREATHER 1	1				
22	90467-140A4	CLIP	1				
23	93211-06635	O-RING	1				
24	91312-06025	BOLT	2				
25	2NL-11186-12	COVER, CYLINDER HEAD SIDE 2	1				
26	2NL-11187-11	COVER, CYLINDER HEAD SIDE 3	1				
27	93210-57634	O-RING	2				

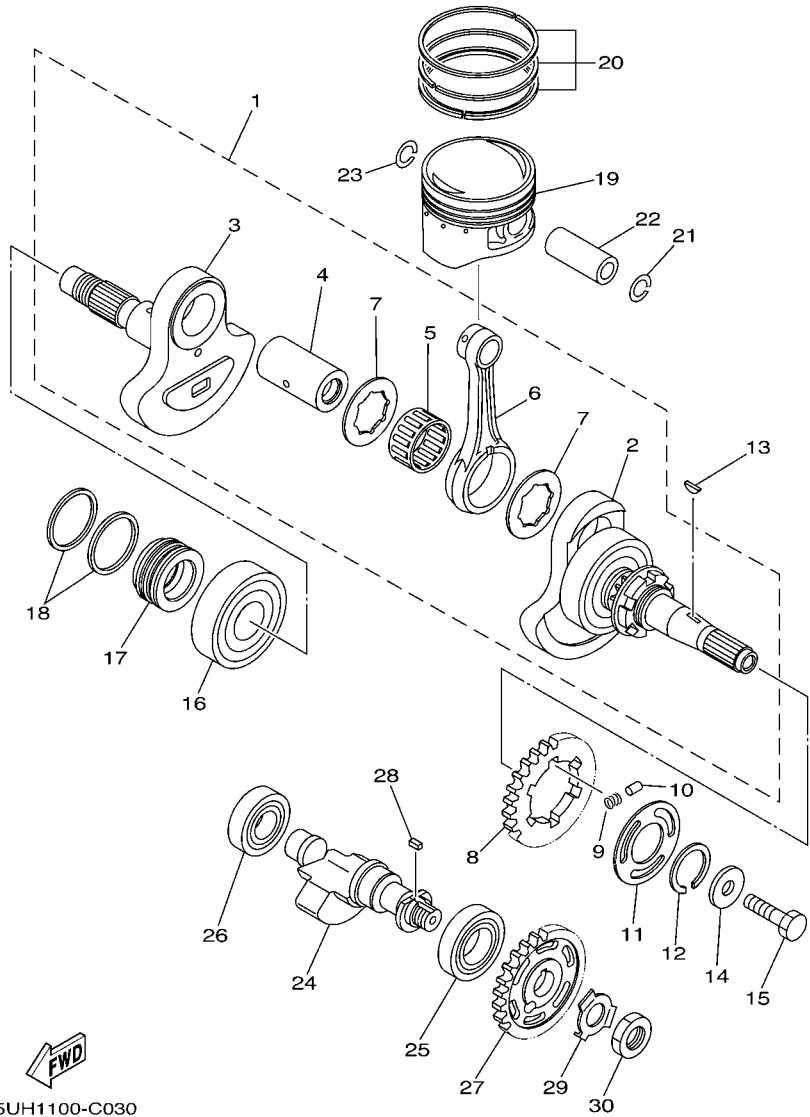

5UH1100-C030

FIG. 3 CRANKSHAFT & PISTON

REF. NO.	PART NO.	DESCRIPTION	USA				REMARKS
1	5UH-11400-00	CRANKSHAFT ASSY	1				
2	5UH-11401-09	.CRANK SUB ASSY 1	1				
3	5UH-11402-09	.CRANK SUB ASSY 2	1				
4	30X-11681-00	.PIN, CRANK 1	1				
5	93310-633P5	.BEARING	1				
6	5UH-11651-00	.ROD, CONNECTING	1				
7	90209-33253	.WASHER	2				
8	5UH-11536-00	GEAR, DRIVE	1				
9	90501-22721	SPRING, COMPRESSION	6				
10	93605-10090	PIN, DOWEL	3				
11	5UH-11565-00	WASHER, BEARING COVER	1				
12	99009-32400	CIRCLIP	1				
13	90280-05048	KEY, WOODRUFF	1				
14	90201-10038	WASHER, PLATE	1				
15	90101-10017	BOLT	1				
16	93306-30611	BEARING	1				
17	5UH-16181-00	SPACER 1	1				
18	5KM-11447-00	SEAL, CRANK	2				
19	5UH-11631-00-C0	PISTON (STD)	1				
	5UH-11636-00	PISTON (0.50MM O/S)	1				AP
	5UH-11638-00	PISTON (1.00MM O/S)	1				AP
20	4GB-11610-00	PISTON RING SET (STD)	1				
	4GB-11610-20	PISTON RING SET (0.50MM O/S)	1				AP
	4GB-11610-40	PISTON RING SET (1.00MM O/S)	1				AP
21	93450-19095	CIRCLIP	1				
22	55V-11633-00	PIN, PISTON	1				
23	93450-19095	CIRCLIP	1				

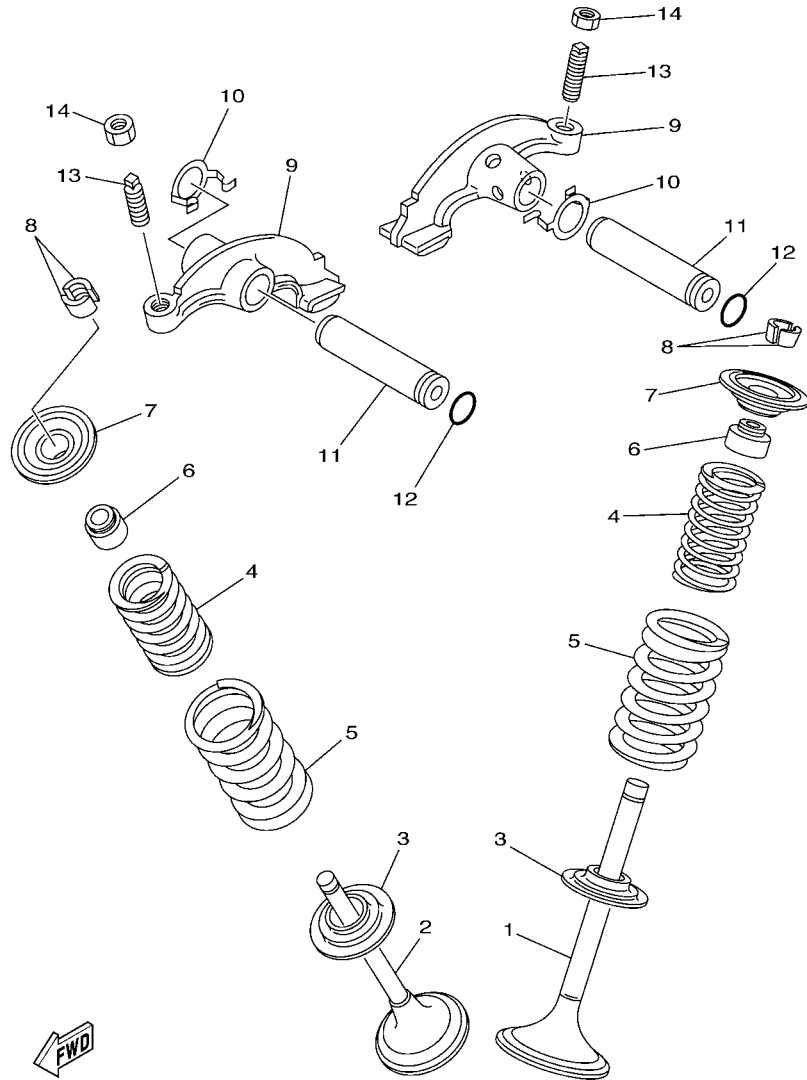

FWD
4KBM100-1040

FIG. 4 VALVE

REF. NO.	PART NO.	DESCRIPTION	USA				REMARKS
1	1UY-12111-01	VALVE, INTAKE	1				
2	1UY-12121-01	VALVE, EXHAUST	1				
3	3Y1-12116-00	SEAT, VALVE SPRING	2				
4	22U-12113-00	SPRING, VALVE INNER	2				
5	1UY-12114-01	SPRING, VALVE OUTER	2				
6	M01-12129-00	SEAL, VALVE STEM	2				
7	3Y1-12117-01	RETAINER, VALVE SPRING	2				
8	1J7-12118-00	COTTER, VALVE	4				
9	3GD-12151-11	ARM, VALVE ROCKER	2				
10	90206-12001	WASHER, WAVE	2				
11	4SH-12156-00	SHAFT, ROCKER 2	2				
12	93210-09165	O-RING	2				
13	31G-12159-02	SCREW, VALVE ADJUSTING	2				
14	31G-12158-00	NUT, LOCK	2				

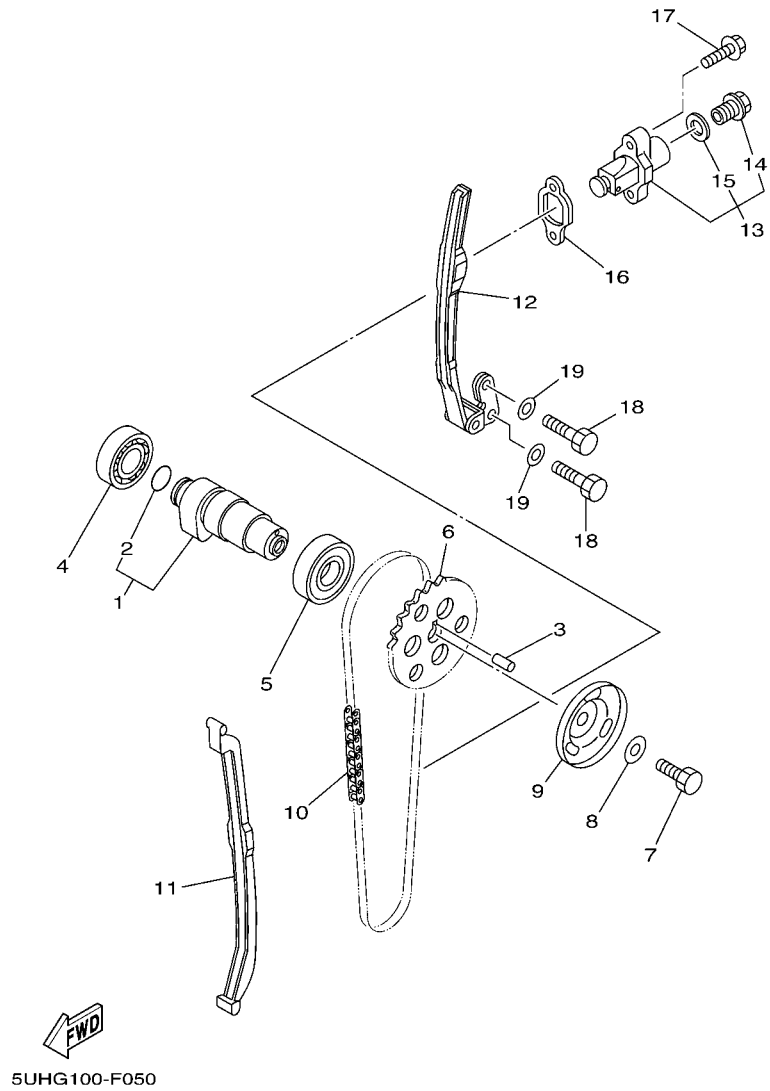
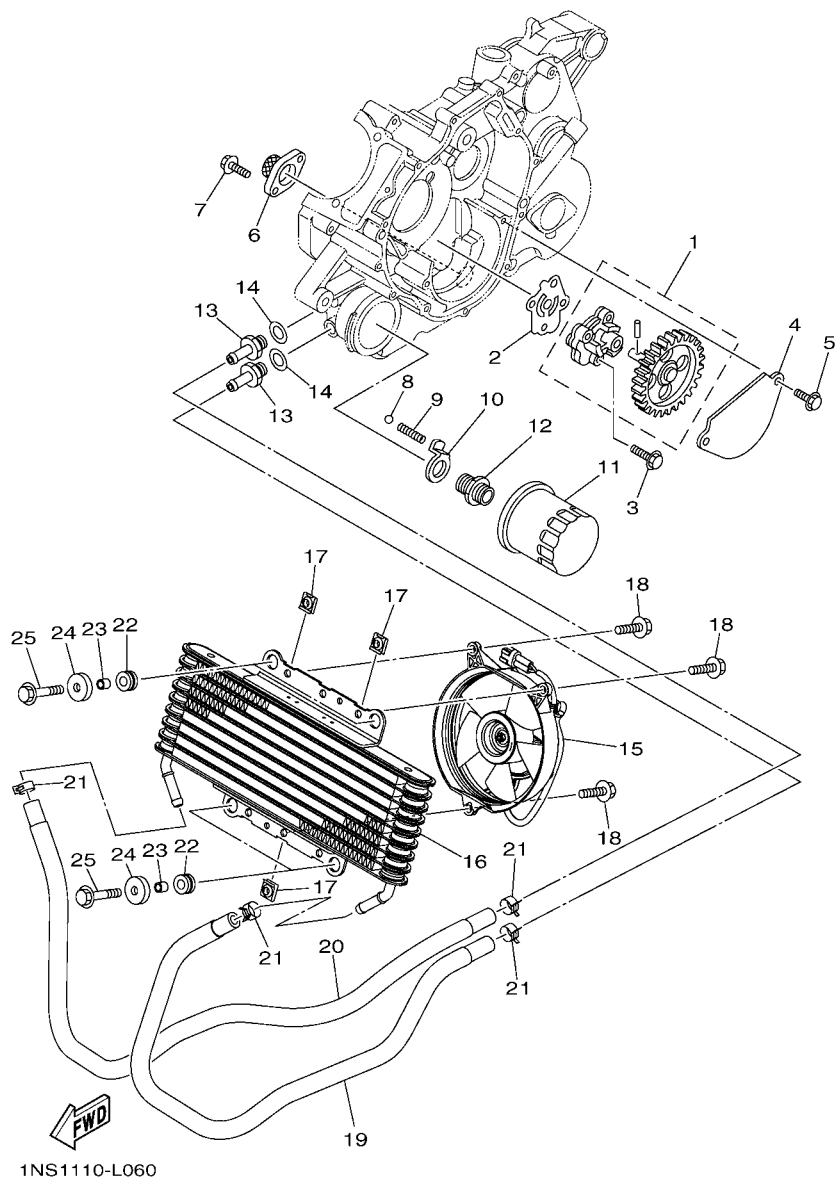

FIG. 5 CAMSHAFT & CHAIN

REF. NO.	PART NO.	DESCRIPTION	USA				REMARKS
1	5UH-12170-10	CAMSHAFT ASSY 1	1				
2	93210-17003	.O-RING	1				
3	93604-10011	PIN, DOWEL	1				
4	93306-00438	BEARING	1				NIHONSEIKO
5	93306-00502	BEARING	1				
6	5UH-12176-00	SPROCKET, CAM CHAIN	1				
7	90101-10016	BOLT	1				
8	90201-10591	WASHER, PLATE	1				
9	4KB-11145-00	PLATE, BREATHER 2	1				
10	94591-87110	CHAIN (92RH2005-110M)	1				
11	5UH-12231-00	GUIDE, STOPPER 1	1				
12	5UH-12241-00	GUIDE, STOPPER 2	1				
13	31G-12210-01	TENSIONER ASSY, CAM CHAIN	1				
14	31G-12222-00	.PLUG	1				
15	31G-12214-00	.GASKET	1				
16	3GD-12213-00	GASKET, TENSIONER CASE	1				
17	95022-06025	BOLT, FLANGE	2				
18	97022-06016	BOLT	2				
19	92902-06600	WASHER, PLATE	2				

FIG. 6 OIL PUMP



REF. NO.	PART NO.	DESCRIPTION	USA				REMARKS
1	5UH-13300-00	OIL PUMP ASSY	1				
2	5UH-13329-00	GASKET, PUMP COVER	1				
3	95022-06025	BOLT, FLANGE	3				
4	5UH-13327-00	COVER, PUMP GEAR	1				
5	95022-06012	BOLT, FLANGE	2				
6	5UH-13411-00	STRAINER, OIL	1				
7	90105-05016	BOLT, FLANGE	2				
8	93505-16006	BALL	1				
9	90501-101A7	SPRING, COMPRESSION	1				
10	5UH-1319K-00	PLATE	1				
11	5GH-13440-20	ELEMENT ASSY, OIL CLEANER	1				
12	90401-20008	BOLT, UNION	1				
13	1NS-13132-00	JOINT	2				
14	90430-14043	GASKET	2				
15	1NS-E2405-00	BLOWER ASSY	1				
16	1NS-E3480-00	ELEMENT, OIL COOLER	1				
17	1NS-E3577-00	CLIP	3				
18	1NS-E3573-00	BOLT 1	3				
19	1NS-E3464-00	HOSE, OIL 1	1				
20	1NS-E3465-00	HOSE, OIL 2	1				
21	90467-150A0	CLIP	4				
22	90480-15235	GROMMET	4				
23	90387-06113	COLLAR	4				
24	90209-06012	WASHER	4				
25	95812-06020	BOLT, FLANGE	4				

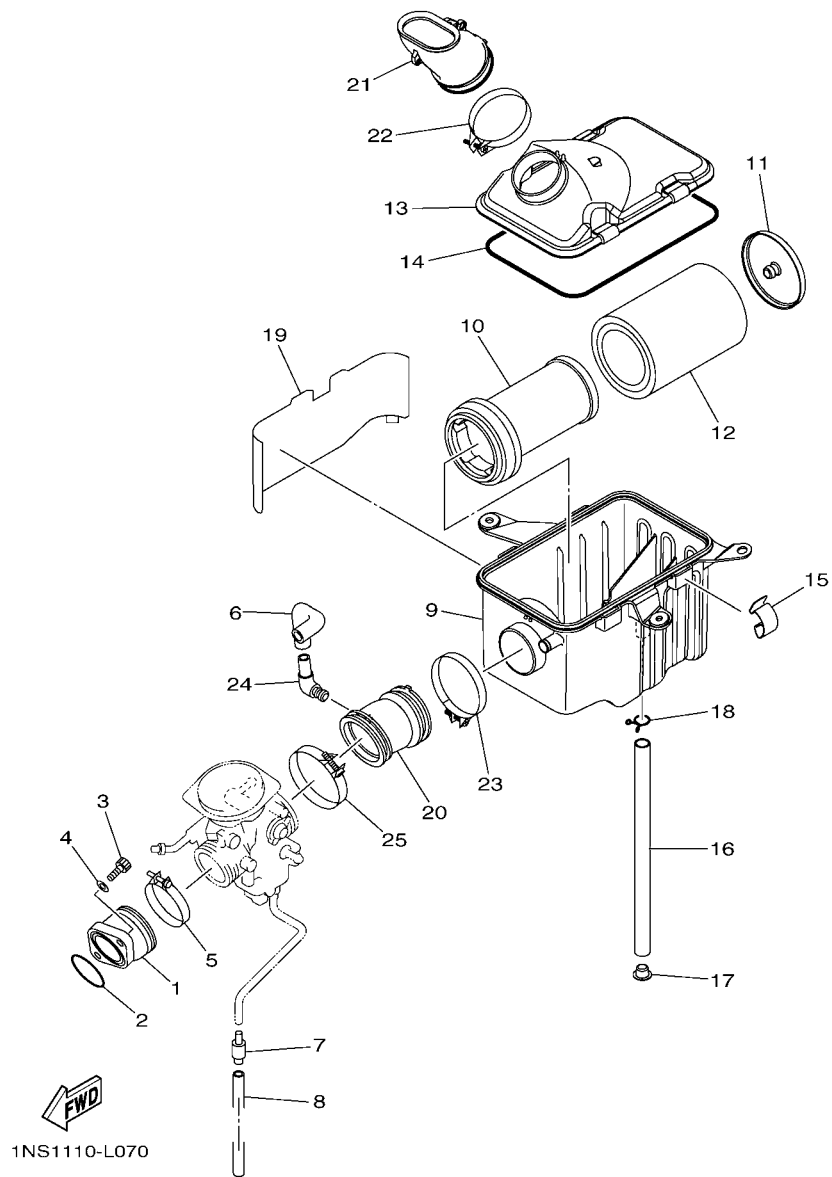
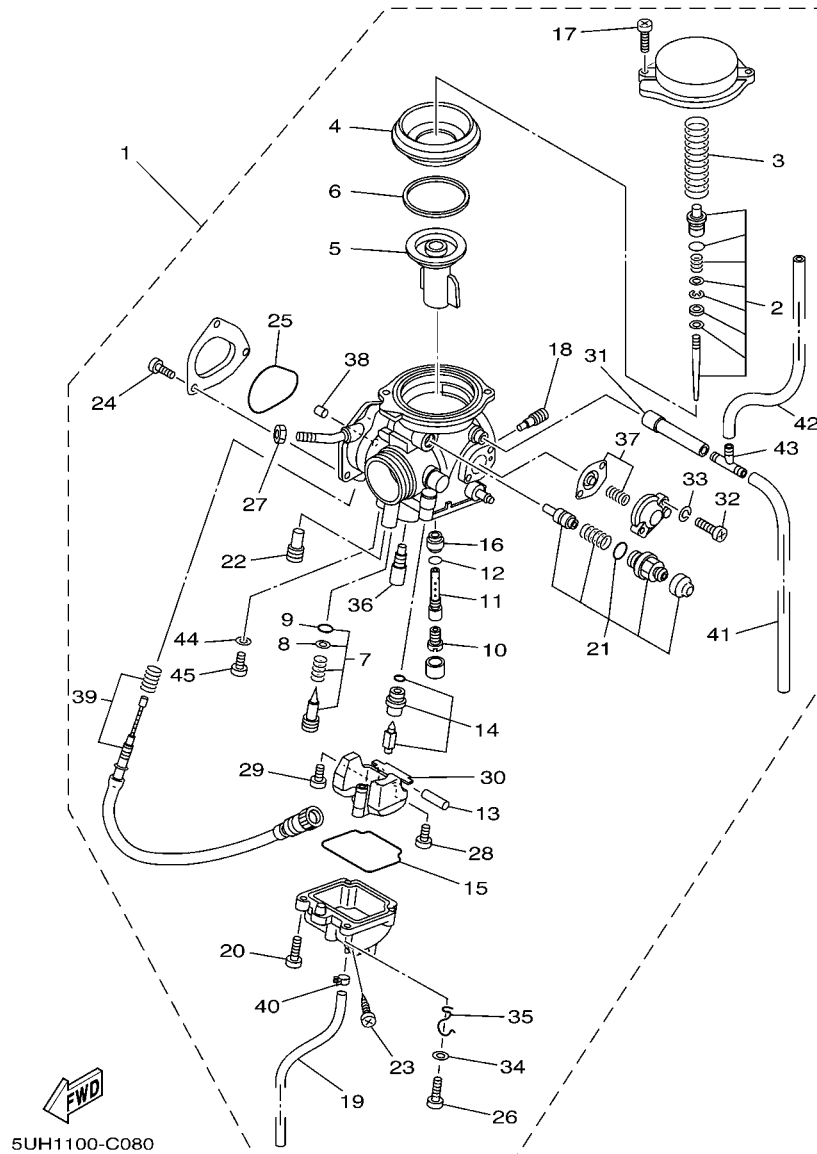

FIG. 7 INTAKE

REF. NO.	PART NO.	DESCRIPTION	USA				REMARKS
1	5UH-13586-00	JOINT, CARBURETOR 1	1				
2	93210-44545	O-RING	1				
3	91312-08025	BOLT	2				
4	90201-08070	WASHER, PLATE	2				
5	90450-47002	HOSE CLAMP ASSY	1				
6	5UH-E4349-00	PIPE	1				
7	24W-14193-00	PIPE	1				
8	91A20-07014	TUBE, FLEXIBLE VINYL	1				
9	5UH-E4411-00	CASE, AIR CLEANER 1	1				
10	5UH-E4458-00	GUIDE	1				
11	5UH-E4468-00	PLATE,ELEMENT FITTING	1				
12	1NS-E4451-00	ELEMENT, AIR CLEANER	1				
13	5UH-E4412-00	CAP, CLEANER CASE 1	1				
14	5UH-E4462-00	SEAL	1				
15	5UH-E4424-00	CLIP, CAP FITTING	4				
16	5UH-E4769-10	PIPE, DRAIN	1				
17	5UH-E4191-00	PLUG, DRAIN	1				
18	5UH-E4438-00	CLIP, DRAIN CLEANER	1				
19	5ND-E442F-00	PROTECTOR	1				
20	5UH-E4453-00	JOINT, AIR CLEANER 1	1				
21	5ND-E4437-02	DUCT	1				
22	90450-58002	HOSE CLAMP ASSY	1				
23	90450-58002	HOSE CLAMP ASSY	1				
24	31A-14419-00	PIPE	1				
25	90450-56008	HOSE CLAMP ASSY	1				



5UH1100-C080

FIG. 8 CARBURETOR

REF. NO.	PART NO.	DESCRIPTION	USA				REMARKS
1	5UH-E4101-11	CARBURETOR ASSY 1	1				
2	5UH-1490J-10	.NEEDLE SET	1				
3	5DM-14933-00	.SPRING, DIAPHRAGM	1				
4	5GH-14940-10	.DIAPHRAGM ASSY	1				
5	5DM-14112-00	.VALVE, THROTTLE 1	1				
6	5GH-14918-10	.RING	1				
7	5UH-14105-10	.PILOT SCREW SET	1				WHITE SPRING
8	3H1-14962-00	..WASHER	1				
9	3H1-14147-00	..O-RING	1				
10	3G2-1423E-51	.JET, MAIN (#128.8)	1				
11	5DM-14261-00	.HOLDER	1				
12	583-14561-00	.O-RING	1				
13	127-14186-00	.PIN, FLOAT	1				
14	4SV-14107-20	.NEEDLE VALVE SET	1				
15	5DM-14561-00	.O-RING	1				
16	5DM-141141-42	.NOZZLE, MAIN	1				
17	4KM-14216-00	.SCREW	2				
18	1HX-14231-16	.JET, MAIN (# 80)	1				
19	4KB-14193-20	.PIPE	1				
20	98580-04010	.SCREW, PAN HEAD	3				
21	5UH-1410A-00	.STARTER SET	1				
22	3G2-1423A-62	.JET, MAIN (#57.5)	1				
23	3FV-14191-00	.PLUG, DRAIN	1				
24	98507-04006	.SCREW, PAN HEAD	3				
25	5FU-E4147-00	.O-RING	1				
26	98507-04014	.SCREW, PAN HEAD	1				
27	522-14161-00	.NUT, CABLE ADJUSTING	1				

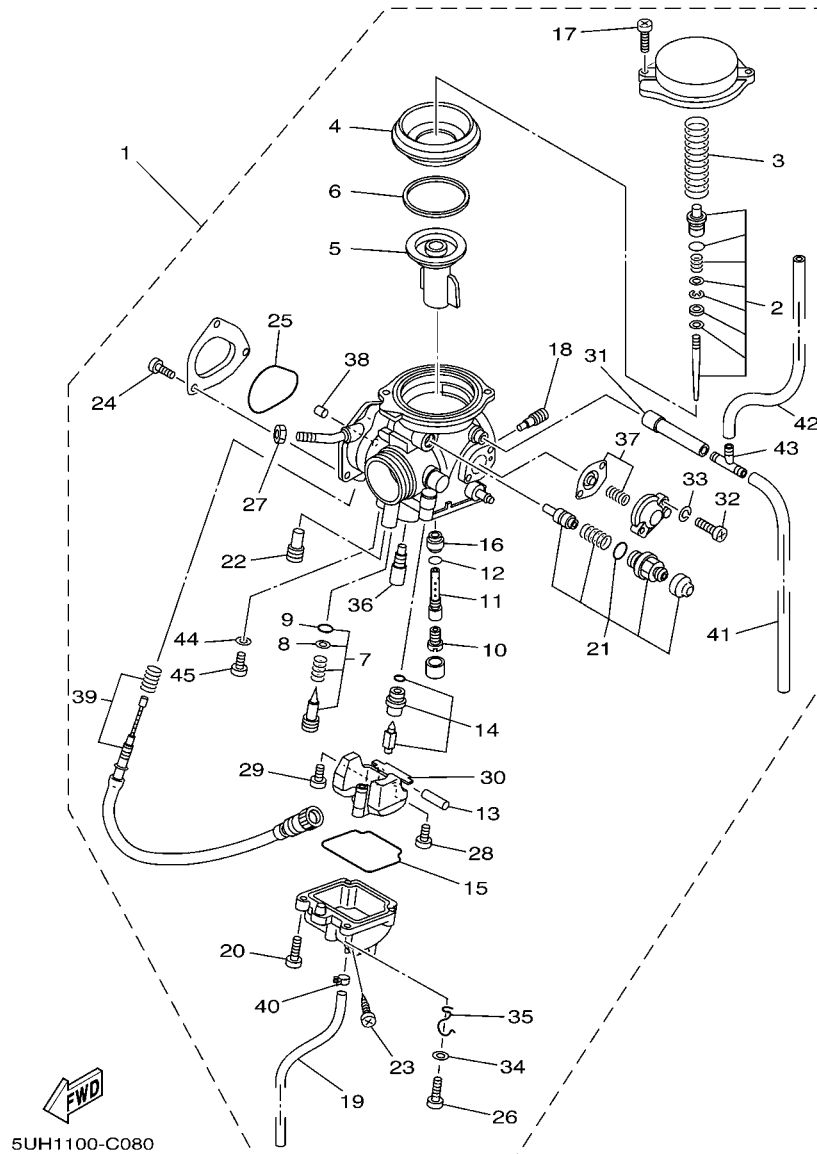

FIG. 8 CARBURETOR

REF. NO.	PART NO.	DESCRIPTION	USA				REMARKS
28	98507-04008	.SCREW, PAN HEAD	1				
29	1FN-14565-00	.SCREW	1				
30	5DM-14985-00	.FLOAT	1				
31	5FU-14197-00	.PIPE	1				
32	98501-04014	.SCREW, PAN HEAD	2				
33	92902-04100	.WASHER, SPRING	2				
34	92907-04600	.WASHER	1				
35	5GH-14937-00	.CLIP	1				
36	4KM-14142-17	.JET, PILOT (# 17.5)	1				
37	5EL-1490H-00	.DIAPHRAGM SET 5	1				
38	5FU-E4155-00	.GUIDE, CABLE	1				
39	5UH-14103-00	.THROTTLE SCREW SET	1				
40	4XE-14937-00	.CLIP	1				
41	5UH-14348-00	.PIPE 1	1				
42	7T9-14987-00	.HOSE	1				
43	5FU-14167-00	.CONNECTOR	1				
44	256-14956-01	.WASHER	1				
45	3DM-14216-00	.SCREW	1				

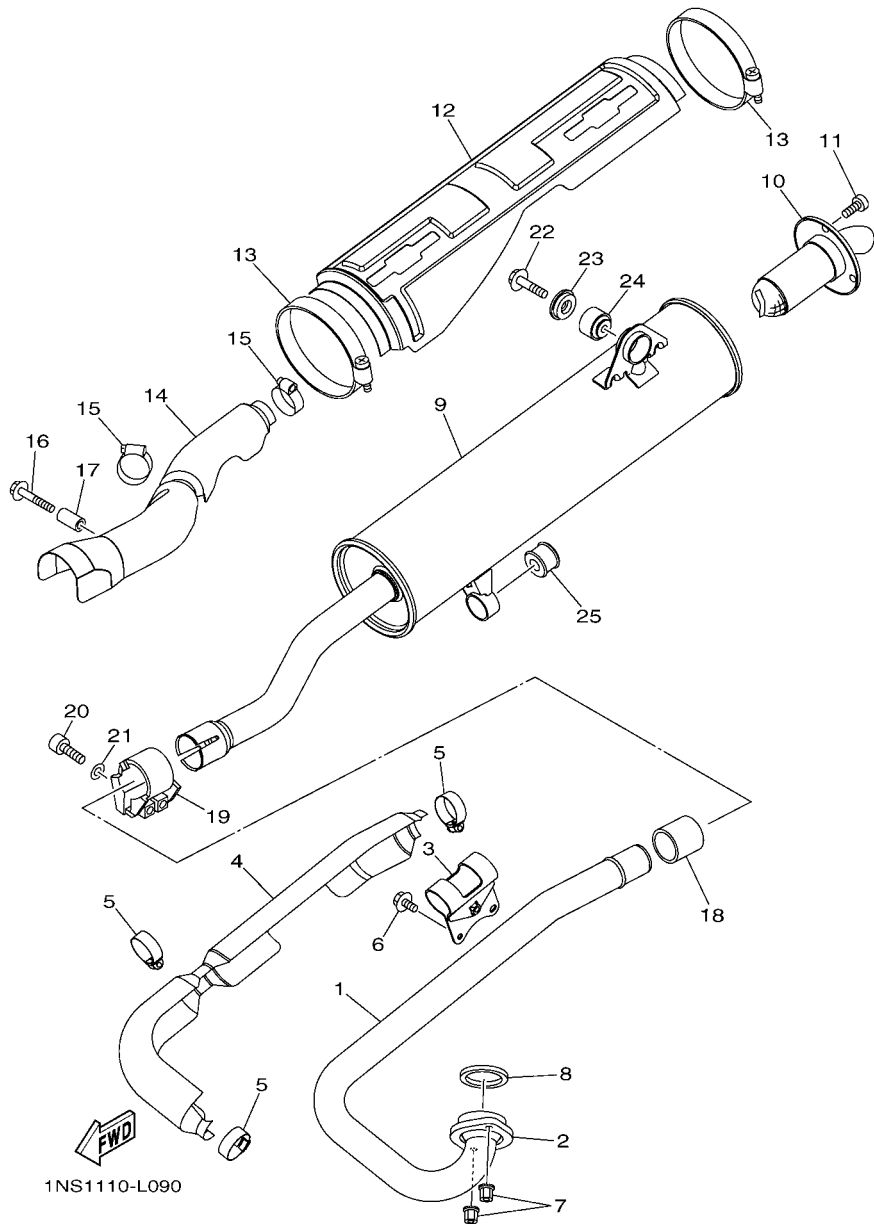

FIG. 9 EXHAUST

REF. NO.	PART NO.	DESCRIPTION	USA				REMARKS
1	5UH-E4611-00	PIPE, EXHAUST 1	1				
2	5UH-E4612-00	NUT, RING	1				
3	1NS-E477R-00	BAND 1	1				
4	5UH-E4628-01	PROTECTOR, EXHAUST PIPE	1				
5	5UH-E477T-00	BAND 2	3				
6	95812-06016	BOLT, FLANGE	3				
7	90179-06668	NUT	2				
8	3GD-14613-00	GASKET, EXHAUST PIPE	1				
9	1NS-E4711-00	MUFFLER 1	1				
10	5ND-E4752-00	PIPE, OUTLET	1				
11	5ND-E4719-00	BOLT, MUFFLER	3				
12	5ND-E4718-00	PROTECTOR, MUFFLER 1	1				
13	5ND-E4788-00	BAND, SILENCER	2				
14	1NS-E4728-00	PROTECTOR, MUFFLER 2	1				
15	5UH-E477T-00	BAND 2	2				
16	9580P-06040	BOLT, FLANGE	1				
17	5UH-E4638-00	COLLAR	1				
18	5ND-E4714-00	GASKET, MUFFLER	1				
19	5ND-E4715-00	BAND, MUFFLER	1				
20	5ND-E4777-00	BOLT	2				
21	5ND-E4759-00	WASHER	2				
22	95812-08040	BOLT, FLANGE	1				
23	3B4-14759-01	WASHER	1				
24	5KM-27414-01	DAMPER	1				
25	1NS-E4737-00	DAMPER, MUFFLER	1				

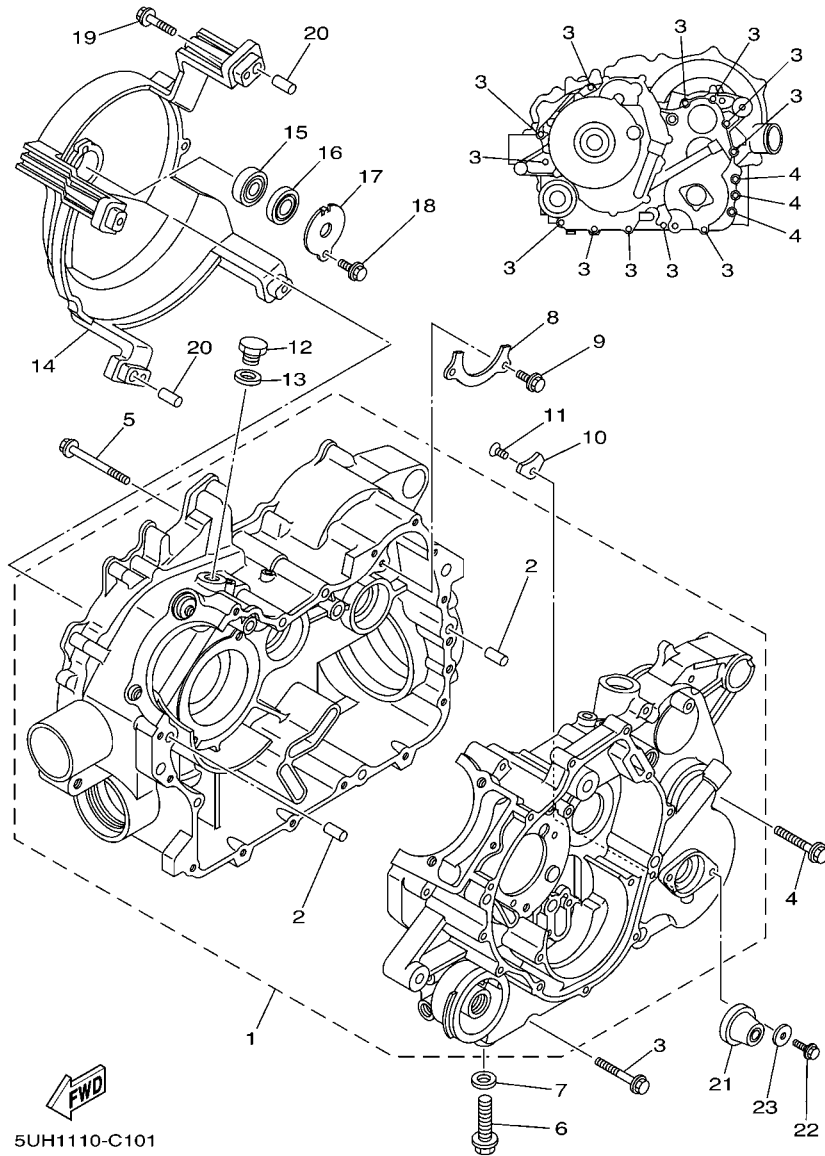

FIG. 10 CRANKCASE

REF. NO.	PART NO.	DESCRIPTION	USA				REMARKS
1	5UH-15100-09	CRANKCASE ASSY	1				
2	99530-10116	.PIN, DOWEL	2				
3	95022-06050	BOLT, FLANGE	12				
4	95022-08045	BOLT, FLANGE	3				
5	95022-06070	BOLT, FLANGE	3				
6	95022-12040	BOLT, FLANGE	1				
7	90201-12172	WASHER, PLATE	1				
8	5GH-15388-00	PLATE, BEARING COVER	1				
9	95822-06012	BOLT, FLANGE	2				
10	2K7-15383-00	PLATE, BEARING COVER	1				
11	90151-06023	SCREW, COUNTERSUNK	1				
12	90340-14029	PLUG, STRAIGHT SCREW	1				
13	214-11198-01	GASKET	1				
14	5UH-15442-00	HOUSING, BEARING	1				
15	93306-20103	BEARING	1				
16	93101-12168	OIL SEAL	1				
17	4WV-15381-00	PLATE, BEARING COVER	1				
18	95022-06012	BOLT, FLANGE	1				
19	95822-06030	BOLT, FLANGE	4				
20	99530-10116	PIN, DOWEL	2				
21	5GH-15385-00	PLUG, BLIND	1				
22	90105-06081	BOLT, FLANGE	2				
23	90201-06095	WASHER, PLATE	2				

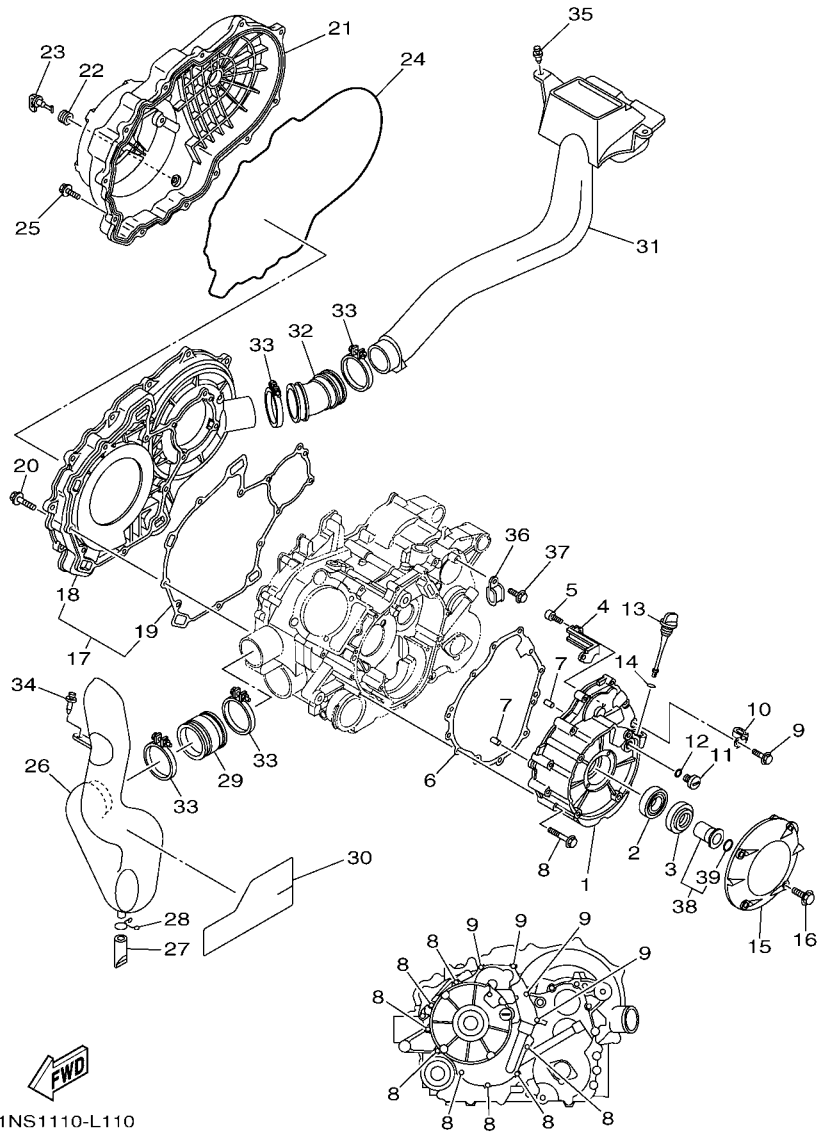

FIG. 11 CRANKCASE COVER 1

REF. NO.	PART NO.	DESCRIPTION	USA				REMARKS
1	5UH-15411-00	COVER, CRANKCASE 1	1				
2	93306-07801	BEARING	1				
3	93102-28017	OIL SEAL	1				
4	5UH-15113-00	PLATE	1				
5	91312-05012	BOLT	2				
6	5UH-15451-00	GASKET, CRANKCASE COVER 1	1				
7	99530-10116	PIN, DOWEL	2				
8	95022-06050	BOLT, FLANGE	8				
9	95022-06030	BOLT, FLANGE	4				
10	90465-08127	CLAMP	1				
11	90340-14117	PLUG, STRAIGHT SCREW	1				
12	93210-14369	O-RING	1				
13	517-15362-10	PLUG, OIL LEVEL	1				
14	93210-19026	O-RING	1				
15	3C2-15492-00	COVER	1				
16	91312-06025	BOLT	4				
17	5UH-15420-00	CRANKCASE COVER ASSY 2	1				
18	5UH-15421-00	.COVER, CRANKCASE 2	1				
19	5UH-15315-00	.SEAL, CRANKCASE	1				
20	95822-06030	BOLT, FLANGE	9				
21	5UH-15431-00	COVER, CRANKCASE 3	1				
22	90480-13018	GROMMET	1				
23	5KM-15351-00	PLUG, DRAIN	1				
24	5UH-15379-00	SEAL, CRANKCASE	1				
25	95822-06020	BOLT, FLANGE	14				
26	5UH-E5471-00	DUCT, AIR	1				
27	5BF-1443E-00	PIPE, DRAIN	1				

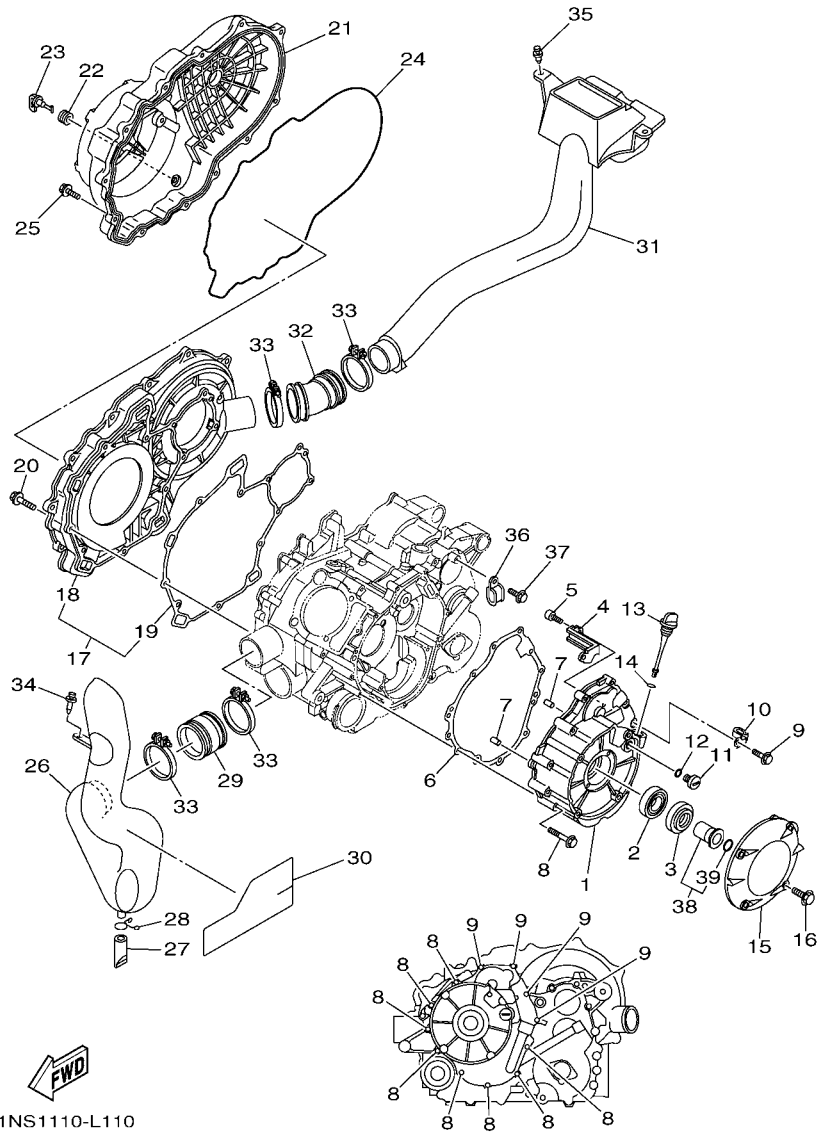
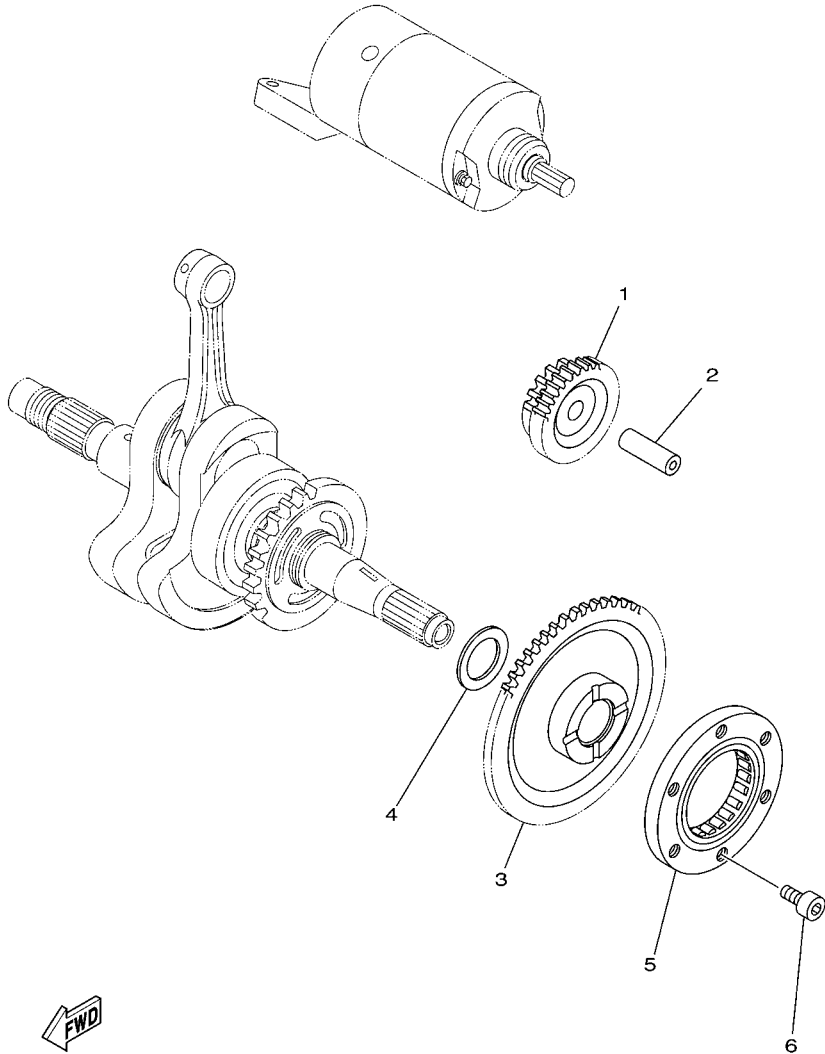

FIG. 11 CRANKCASE COVER 1

REF. NO.	PART NO.	DESCRIPTION	USA				REMARKS
28	90467-160A4	CLIP	1				
29	5ND-E5472-00	SEAL, AIR DUCT	1				
30	1NS-E5491-00	PROTECTOR	1				
31	5ND-E5473-00	DUCT, AIR	1				
32	5UH-E5474-00	SEAL, AIR DUCT	1				
33	90450-64002	HOSE CLAMP ASSY	4				
34	90269-06800	RIVET	1				
35	90269-08813	RIVET	2				
36	90461-08134	CLAMP	1				
37	95022-06012	BOLT, FLANGE	1				
38	3D5-15730-00	STARTER PULLEY ASSY	1				
39	93210-16290	.O-RING	1				

FIG. 12 STARTER CLUTCH

REF. NO.	PART NO.	DESCRIPTION	USA				REMARKS
1	5UH-15512-00	GEAR, IDLER 1	1				
2	1VJ-15521-00	SHAFT 1	1				
3	5UH-15517-00	GEAR, IDLER 2	1				
4	90201-25290	WASHER, PLATE	1				
5	5KM-15590-00	STARTER ONE-WAY ASSY	1				
6	91312-08016	BOLT	3				



5UH1100-C130

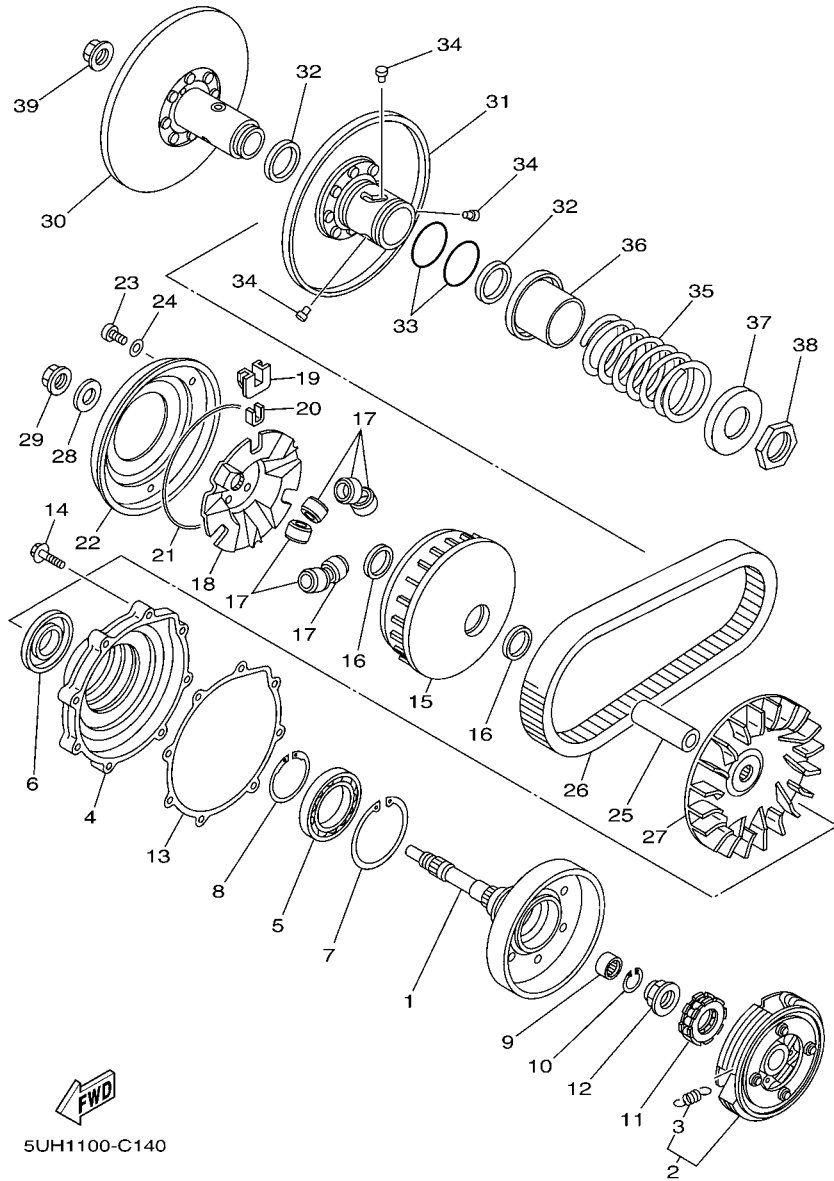
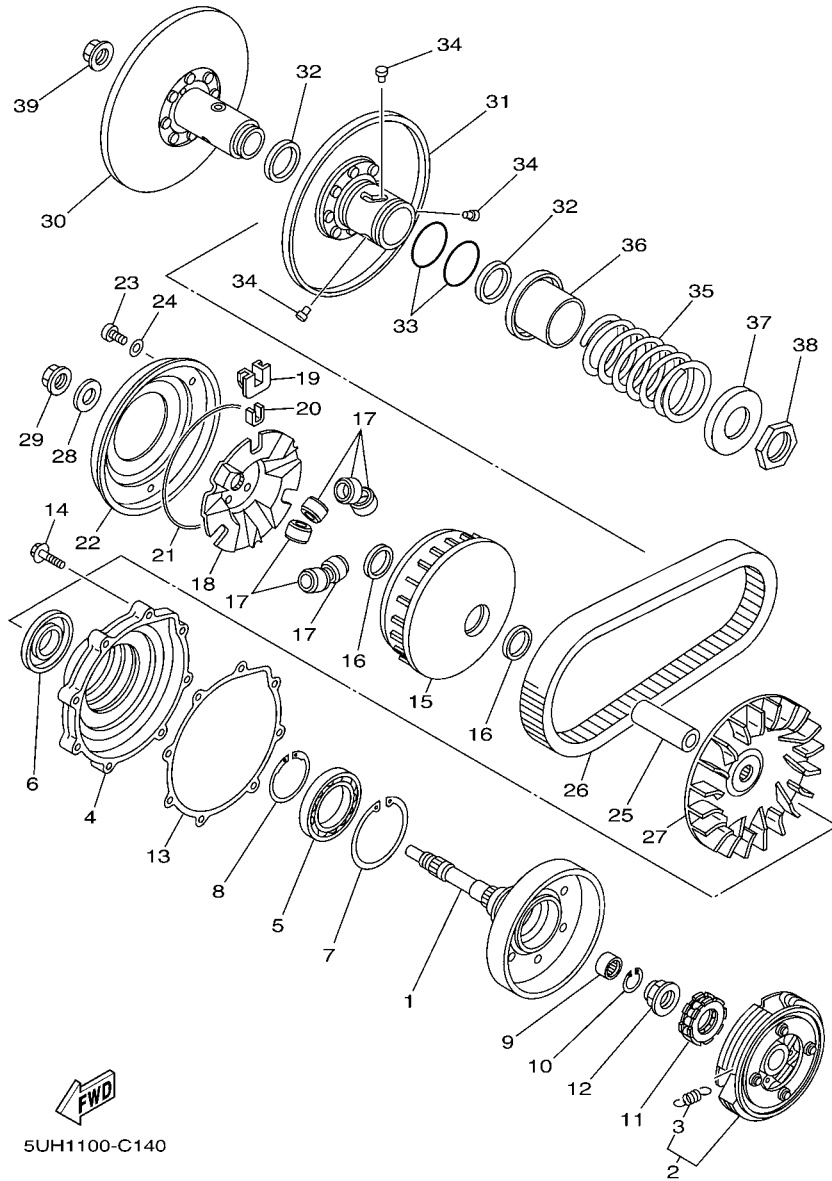

FIG. 13 CLUTCH

REF. NO.	PART NO.	DESCRIPTION	USA				REMARKS
1	5UH-16611-00	CLUTCH HOUSING COMP.	1				
2	5UH-16620-00	CLUTCH CARRIER ASSY	1				
3	5UH-16626-00	.SPRING, CLUTCH WEIGHT 1	4				
4	5UH-15163-00	HOUSING, BEARING 1	1				
5	93316-01003	BEARING	1				
6	93102-32483	OIL SEAL	1				
7	99009-80500	CIRCLIP	1				
8	93410-46079	CIRCLIP	1				
9	93315-21813	BEARING	1				
10	93450-24062	CIRCLIP	1				
11	5GH-16664-00	BEARING, ONE WAY	1				
12	90179-22005	NUT	1				
13	5UH-15463-00	GASKET, COVER PINION 2	1				
14	95022-06030	BOLT, FLANGE	8				
15	5UH-17620-00	PRIMARY SLIDING SHEAVE COMP.	1				
16	93101-31167	OIL SEAL	2				
17	4WV-17632-00	WEIGHT	6				
18	5UH-17623-00	CAM	1				
19	4WV-17653-00	SLIDER	3				
20	4WV-17654-01	SPACER 1	3				
21	93211-52001	O-RING	1				
22	5UH-17639-00	STOPPER	1				
23	90157-04006	SCREW, PAN HEAD	3				
24	90201-047R9	WASHER, PLATE	3				
25	5UH-17645-00	COLLAR	1				
26	5UH-17641-01	V-BELT	1				
27	5UH-17611-00	SHEAVE, PRIMARY FIXED	1				



5UH1100-C140

FIG. 13 CLUTCH

REF. NO.	PART NO.	DESCRIPTION	USA				REMARKS
28	90201-190T7	WASHER, PLATE	1				
29	90179-16005	NUT	1				
30	5UH-17660-00	SECONDARY FIXED SHEAVE COMP.	1				
31	5UH-17670-00	SECONDARY SLIDING SHEAVE	1				
32	93104-41119	OIL SEAL	2				
33	93210-44545	O-RING	2				
34	4CW-17664-00	PIN, GUIDE	3				
35	90501-580A0	SPRING, COMPRESSION	1				
36	5UH-17684-00	SEAT, SECONDARY SPRING	1				
37	5UH-17644-00	SEAT, SPRING	1				
38	90170-36279	NUT	1				
39	90179-16005	NUT	1				

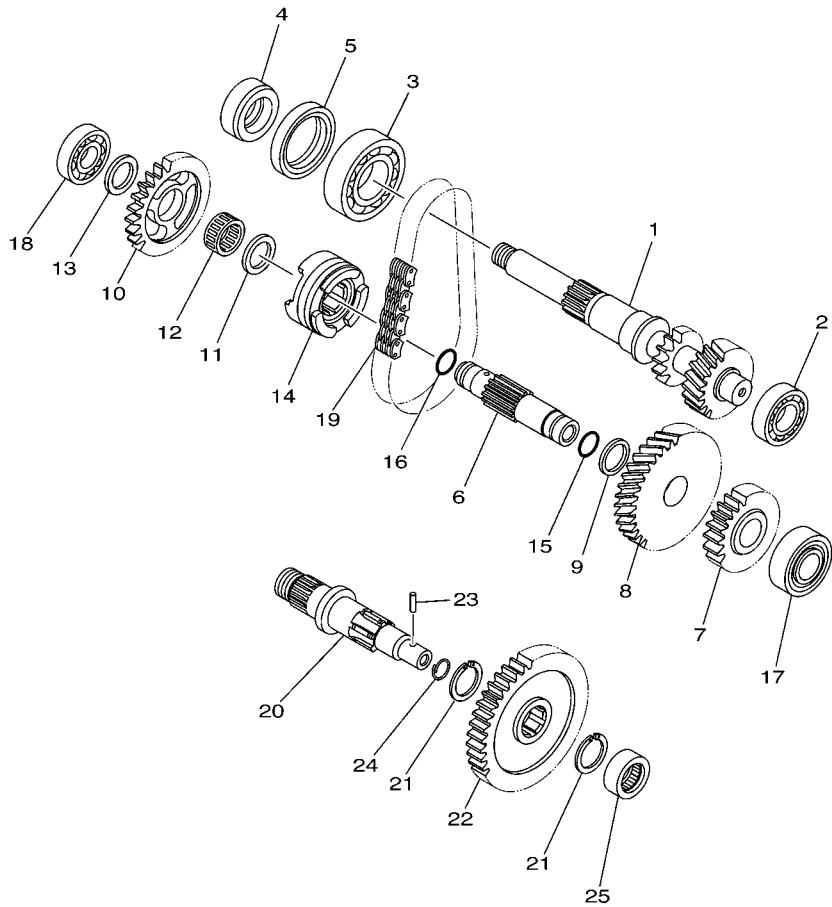

FWD
5UHG100-F150

FIG. 14 TRANSMISSION

REF. NO.	PART NO.	DESCRIPTION	USA				REMARKS
1	5UH-17681-20	SHAFT, SECONDARY	1				
2	93306-00401	BEARING	1				
3	93306-20601	BEARING	1				
4	5UH-17168-00	COLLAR 2	1				
5	93102-42004	OIL SEAL	1				
6	5UH-17421-10	AXLE, DRIVE	1				
7	5UH-17582-11	GEAR, MIDDLE DRIVE (21T)	1				
8	5UH-17223-10	GEAR, HIGH WHEEL (35T)	1				
9	90201-21015	WASHER, PLATE	1				
10	5UH-17453-00	SPROCKET, DRIVEN (26T)	1				
11	90201-20278	WASHER, PLATE	1				
12	93310-420F2	BEARING	1				
13	90201-17013	WASHER, PLATE	1				
14	5UH-17285-00	CLUTCH, DOG	1				
15	93210-17003	O-RING	1				
16	93210-14299	O-RING	1				
17	93306-20464	BEARING	1				
18	93306-20306	BEARING	1				
19	94591-54034	CHAIN (23RH302-34ASM)	1				
20	5UH-17523-00	SHAFT	1				
21	93440-25084	CIRCLIP	2				
22	5UH-17583-01	GEAR, MIDDLE DRIVEN (41T)	1				
23	93603-14240	PIN, DOWEL	1				
24	93440-14155	CIRCLIP	1				
25	93311-42077	BEARING	1				

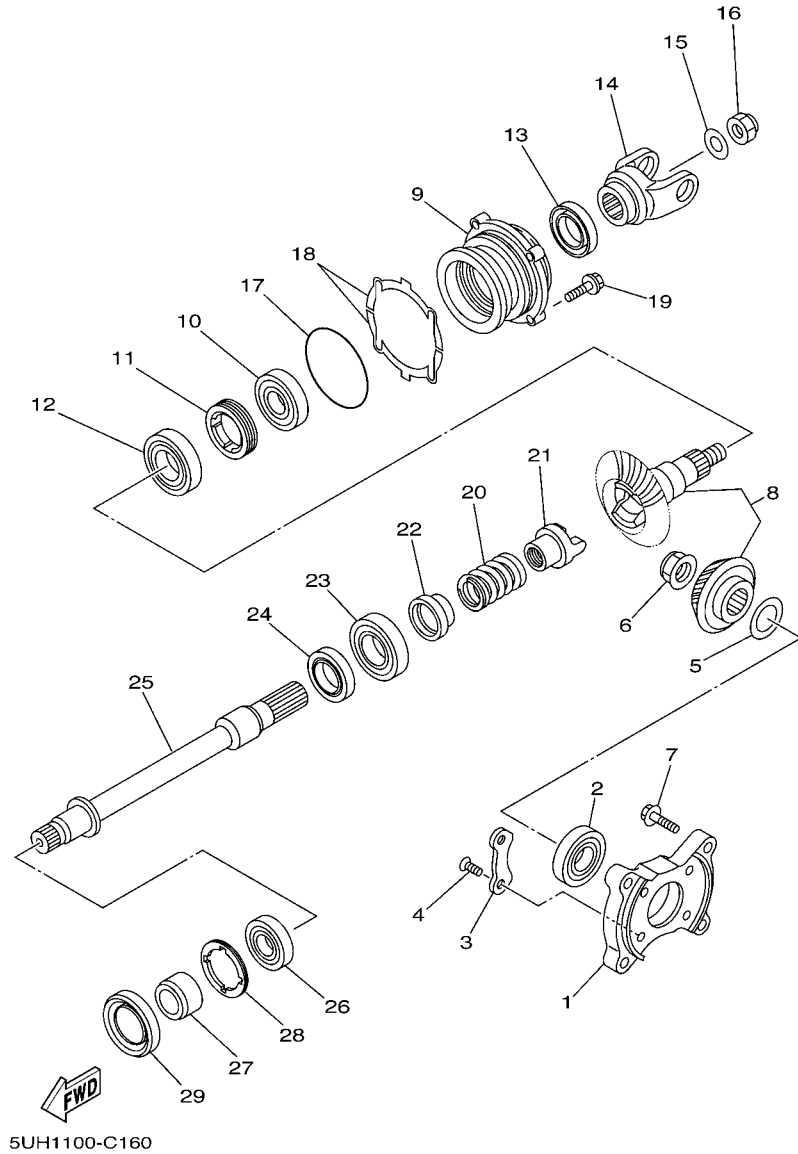

FIG. 15 MIDDLE DRIVE GEAR

REF. NO.	PART NO.	DESCRIPTION	USA				REMARKS
1	5UH-17521-00	HOUSING, BEARING	1				
2	93306-20532	BEARING	1				
3	11H-15383-02	PLATE, BEARING COVER	2				
4	90149-08013	SCREW	4				
5	5KM-17531-00	SHIM, PINION (0.1T)	1				UR
	5KM-17531-10	SHIM, PINION (0.15T)	1				UR
	5KM-17531-20	SHIM, PINION (0.2T)	1				UR
	5KM-17531-30	SHIM, PINION (0.3T)	1				UR
	5KM-17531-40	SHIM, PINION (0.4T)	1				UR
	5KM-17531-50	SHIM, PINION (0.5T)	1				UR
	5KM-17531-60	SHIM, PINION (0.55T)	1				UR
	5KM-17531-70	SHIM, PINION (0.6T)	1				UR
6	90179-22015	NUT	1				
7	90105-08150	BOLT, FLANGE	4				
8	5UH-17530-10	PINION SET	1				
9	5GH-17551-00	HOUSING, BEARING	1				
10	93306-30538	BEARING	1				
11	90179-65305	NUT	1				
12	93306-20715	BEARING	1				
13	93101-35097	OIL SEAL	1				
14	5UH-17556-10	YOKE, JOINT	1				
15	90201-166R6	WASHER, PLATE	1				
16	90179-16006	NUT	1				
17	93210-78544	O-RING	1				
18	5GH-17531-00	SHIM, PINION (0.1T)	2				UR
	5GH-17531-10	SHIM, PINION (0.15T)	2				UR
	5GH-17531-20	SHIM, PINION (0.2T)	2				UR

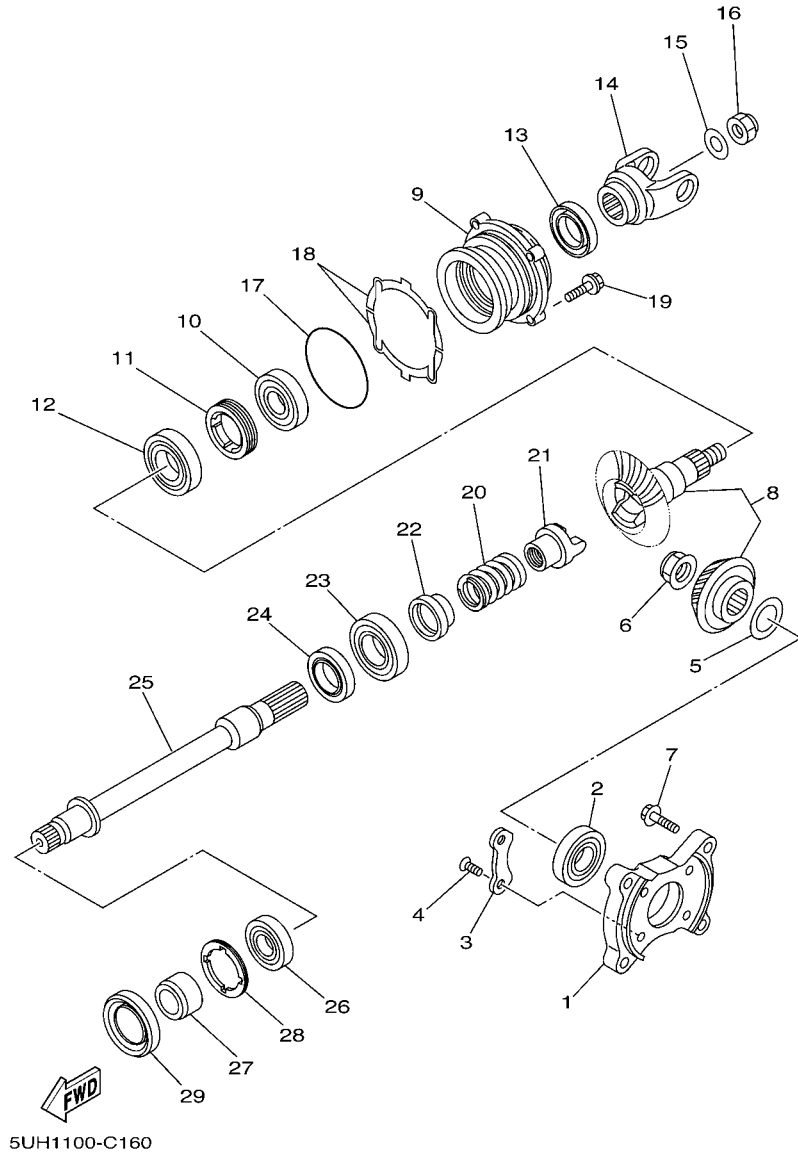

FIG. 15 MIDDLE DRIVE GEAR

REF. NO.	PART NO.	DESCRIPTION	USA				REMARKS
18	5GH-17531-30	SHIM, PINION (0.3T)	2				UR
	5GH-17531-40	SHIM, PINION (0.4T)	2				UR
	5GH-17531-50	SHIM, PINION (0.5T)	2				UR
	5GH-17531-60	SHIM, PINION (0.6T)	2				UR
19	90119-08114	BOLT, WITH WASHER	4				
20	90501-650L5	SPRING, COMPRESSION	1				
21	4VR-17527-00	CAM, DRIVEN	1				
22	5UH-17585-00	COLLAR, GEAR	1				
23	93306-00612	BEARING	1				
24	93102-30170	OIL SEAL	1				
25	5UH-1761A-00	SHAFT, 1	1				
26	93306-20582	BEARING	1				
27	90387-252R2	COLLAR	1				
28	90179-55660	NUT	1				
29	93102-35380	OIL SEAL	1				

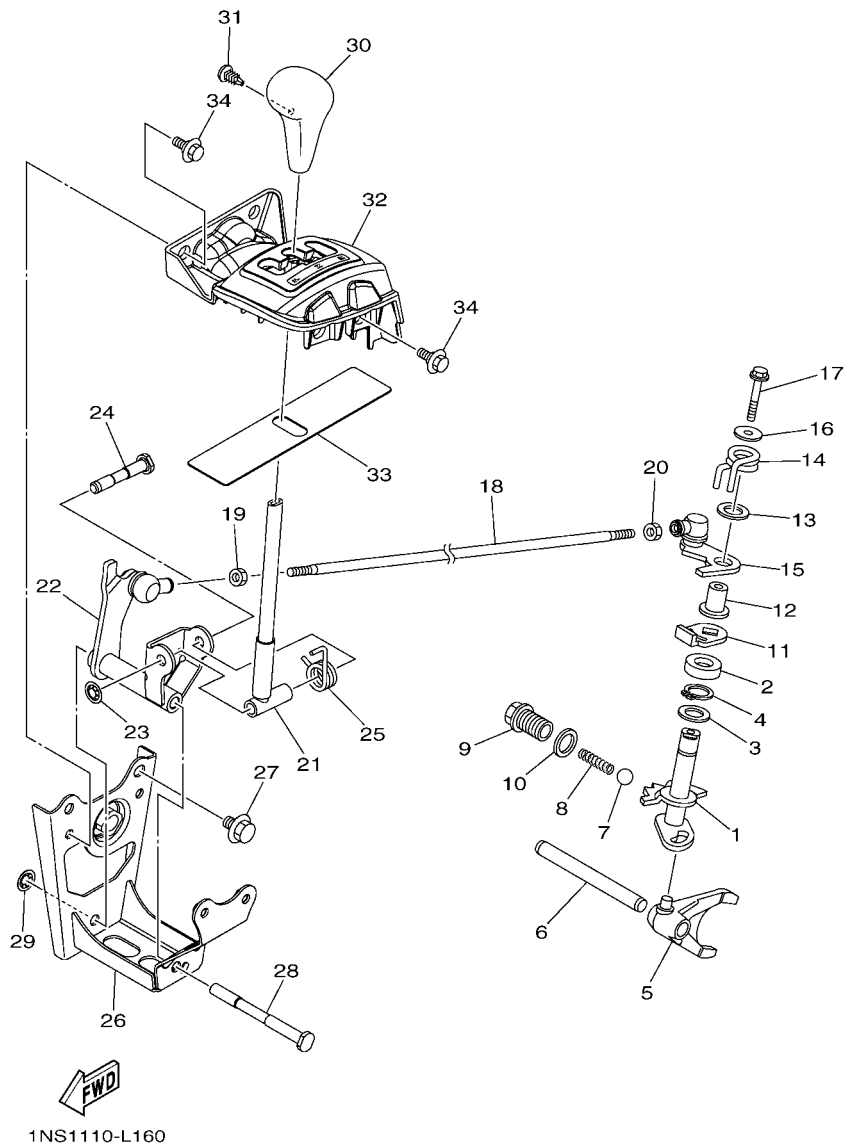

FIG. 16 SHIFT SHAFT

REF. NO.	PART NO.	DESCRIPTION	USA				REMARKS
1	5UH-18103-00	SHIFT SHAFT COMP.	1				
2	93102-15212	OIL SEAL	1				
3	90201-15701	WASHER, PLATE (T=1.0)	1				
4	93440-15012	CIRCLIP	1				
5	5UH-18511-00	FORK, SHIFT 1	1				
6	2A6-18535-00	BAR, SHIFT FORK GUIDE 2	1				
7	93503-08007	BALL	1				
8	90501-10353	SPRING, COMPRESSION	1				
9	90105-14003	BOLT, FLANGE	1				
10	90430-14194	GASKET	1				
11	4SH-18198-00	LEVER	1				
12	90387-0613B	COLLAR	1				
13	90201-132G5	WASHER, PLATE	1				
14	90508-35764	SPRING, TORSION	1				
15	1NS-18191-00	LEVER	1				
16	90201-06036	WASHER, PLATE	1				
17	95812-06035	BOLT, FLANGE	1				
18	1NS-18115-00	ROD, SHIFT	1				
19	90170-06228	NUT(COUNTER CLOCKWISE)	1				
20	95304-06700	NUT	1				
21	1NS-E8190-00	LEVER COMP. 1	1				
22	1NS-E8169-00	ARM, SHIFT 2	1				
23	90183-080A1	NUT, SPRING	1				
24	3B4-18125-00	SHAFT, SHIFT	1				
25	3B4-18196-00	SPRING, RETURN	1				
26	1NS-E8380-00	SHIFTER BRKT. ASSY	1				
27	95812-08012	BOLT, FLANGE	2				

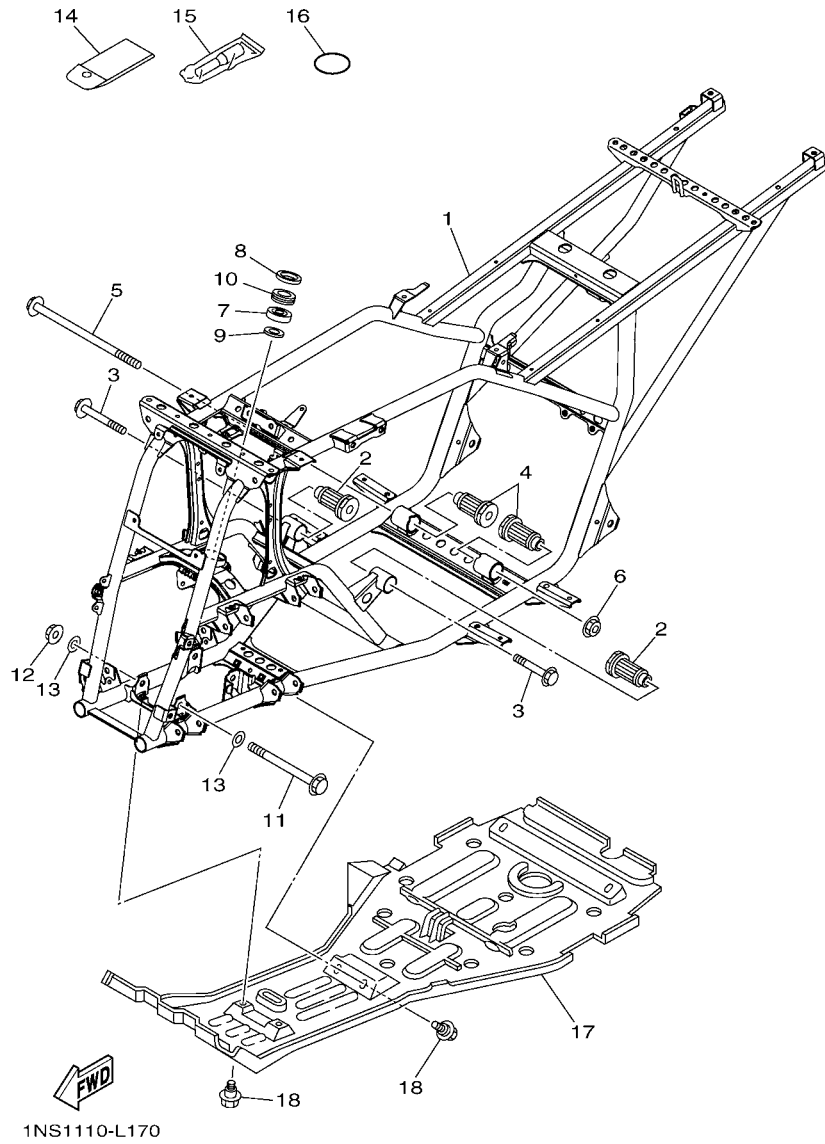
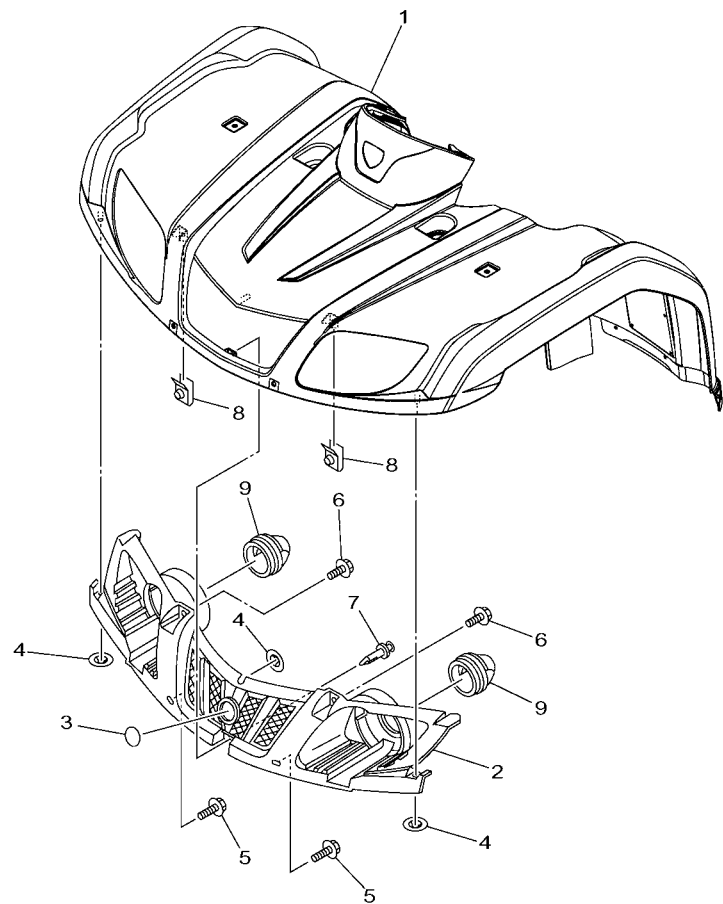

FIG. 17 FRAME

REF. NO.	PART NO.	DESCRIPTION	USA				REMARKS
1	1NS-F1110-00	FRAME COMP.	1				
2	5UH-E5336-00	DAMPER, ENGINE MOUNT 3	2				
3	95812-10080	BOLT, FLANGE	2				
4	5UH-E5336-00	DAMPER, ENGINE MOUNT 3	2				
5	90105-10284	BOLT, FLANGE	1				
6	95602-10200	NUT, U FLANGE	1				
7	93306-203YN	BEARING	1				
8	93102-25081	OIL SEAL	1				
9	93102-25099	OIL SEAL	1				
10	2GU-23872-00	HOLDER, BEARING	1				
11	90105-10051	BOLT, FLANGE	2				
12	95602-10200	NUT, U FLANGE	2				
13	90201-10035	WASHER, PLATE	4				
14	1CT-F8100-00	TOOL KIT	1				
15	1NV-2811A-01	GAUGE, AIR	1				
16	93210-64297	O-RING	1				
17	5ND-F147A-02	GUARD, ENGINE 1	1				
18	90109-06172	BOLT	8				

FIG. 18 FRONT FENDER



1NS1110-L180

REF. NO.	PART NO.	DESCRIPTION	USA				REMARKS
1	5UH-F1500-H1	FRONT FENDER ASSY	1				UR FOR PDG
	5UH-F1500-J1	FRONT FENDER ASSY	1				UR FOR DPBSN
2	5UH-F8309-01	GRILLE, FRONT	1				
3	5FU-F175B-01	TUNING FORK MARK	1				
4	90183-08800	NUT, SPRING	3				
5	90119-06157	BOLT, WITH WASHER	2				
6	90119-06157	BOLT, WITH WASHER	2				
7	90269-06804	RIVET	1				
8	90183-06053	NUT, SPRING	2				
9	5UH-F8349-00	CAP	2				

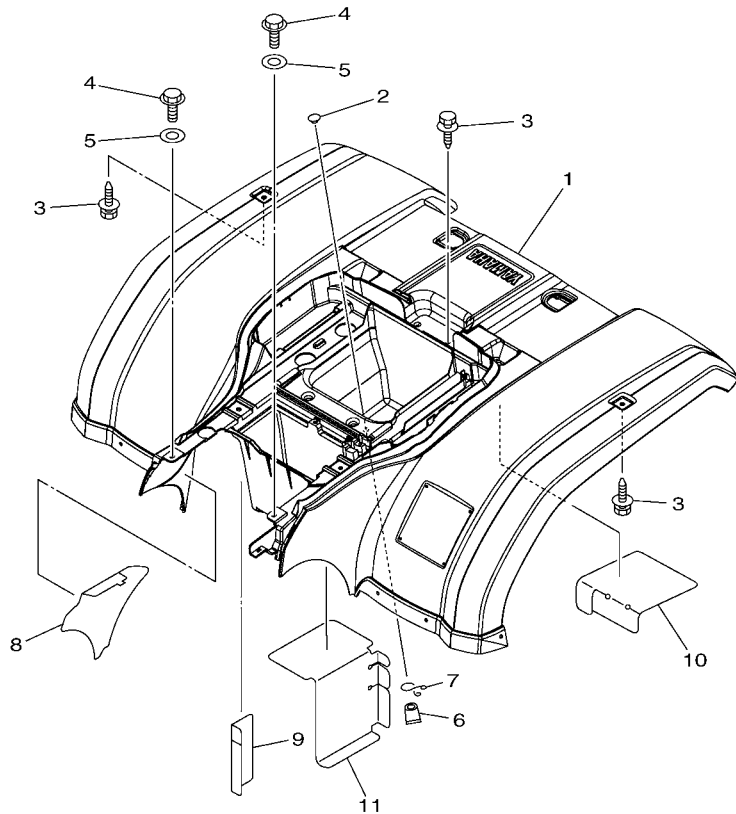
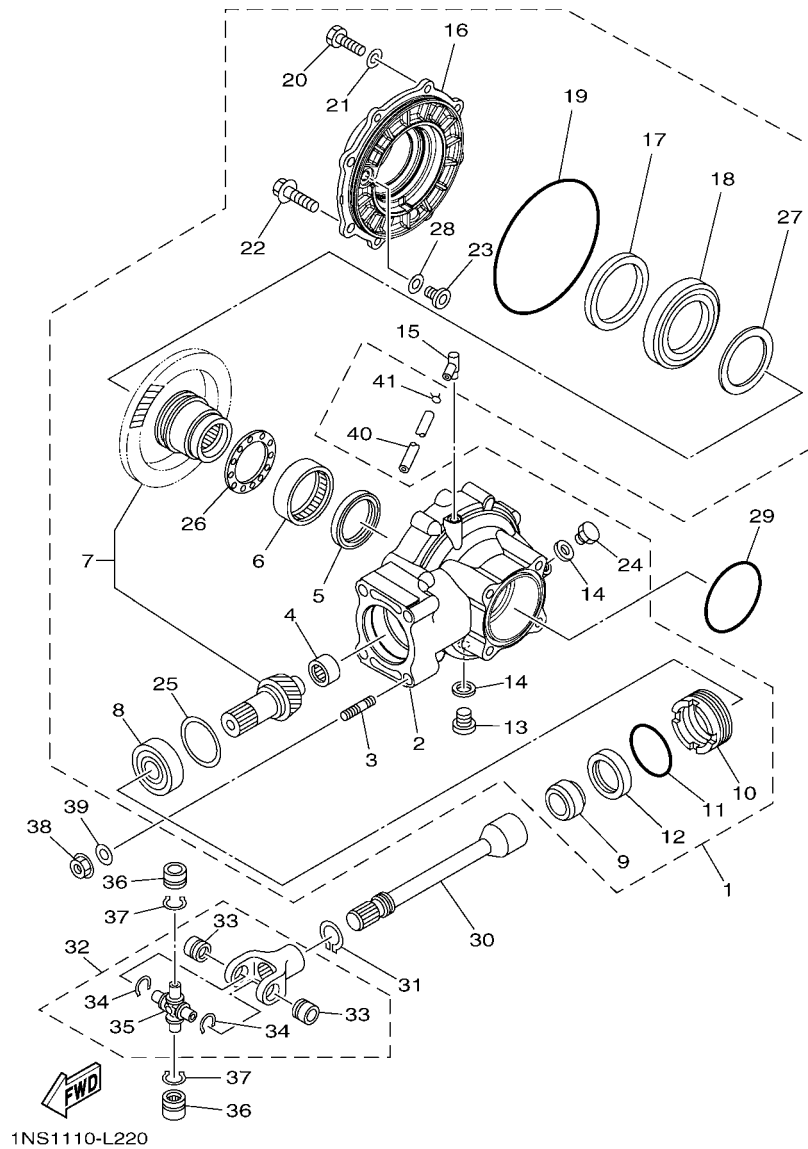

FIG. 19 REAR FENDER

REF. NO.	PART NO.	DESCRIPTION	USA				REMARKS
1	5ND-F1600-W1	REAR FENDER ASSY.	1				UR FOR PDG
	5ND-F1600-X1	REAR FENDER ASSY.	1				UR FOR DPBSN
2	90338-09801	PLUG	1				
3	90119-06157	BOLT, WITH WASHER	3				
4	90105-06833	BOLT, FLANGE	2				
5	90201-06036	WASHER, PLATE	2				
6	5BF-1443E-00	PIPE, DRAIN	1				
7	90467-160A4	CLIP	1				
8	5ND-F163A-02	COVER, REAR FENDER 1	1				
9	5ND-F163E-00	COVER, REAR FENDER 2	1				
10	5ND-F1652-00	PROTECTOR	1				
11	1NS-F163F-00	COVER, REAR FENDER 3	1				

 1NS1110-L190



1NS1110-L220

FIG. 22 DRIVE SHAFT

REF. NO.	PART NO.	DESCRIPTION	USA				REMARKS
1	1NS-G6101-00	REAR AXLE GEAR CASE ASSY	1				
2	1NS-G6151-00	.HOUSING, DRIVE SHAFT	1				
3	90116-10593	.BOLT, STUD	4				
4	4XE-G6102-00	.BEARING ASSY	1				
5	93101-52116	.OIL SEAL	1				
6	93317-855Y9	.BEARING	1				
7	5GT-Y4612-00	.RING GEAR SET	1				
8	93306-305Y6	.BEARING	1				
9	90387-255H9	.COLLAR	1				
10	29U-46125-00	.RETAINER, BEARING	1				
11	93210-59531	.O-RING	1				
12	93101-38098	.OIL SEAL	1				
13	90340-14046	.PLUG, STRAIGHT SCREW	1				
14	214-11198-01	.GASKET	2				
15	2N4-15371-00	.BREATHER	1				
16	1NS-G6152-00	.HOUSING, BEARING	1				
17	93102-65386	.OIL SEAL	1				
18	93316-013Y0	.BEARING	1				
19	93211-51749	.O-RING	1				
20	97022-08025	.BOLT	6				
21	92902-08600	.WASHER, PLATE	6				
22	95812-10025	.BOLT, FLANGE	2				
23	5FU-G6156-00	.STOPPER, RING GEAR	1				
24	90340-14029	.PLUG, STRAIGHT SCREW	1				
25	4XE-E7537-15	.SHIM, THRUST(T=0.15MM)	1				UR
	4XE-E7537-30	.SHIM, THRUST(T=0.30MM)	1				UR
	4XE-E7537-40	.SHIM, THRUST(T=0.40MM)	1				UR

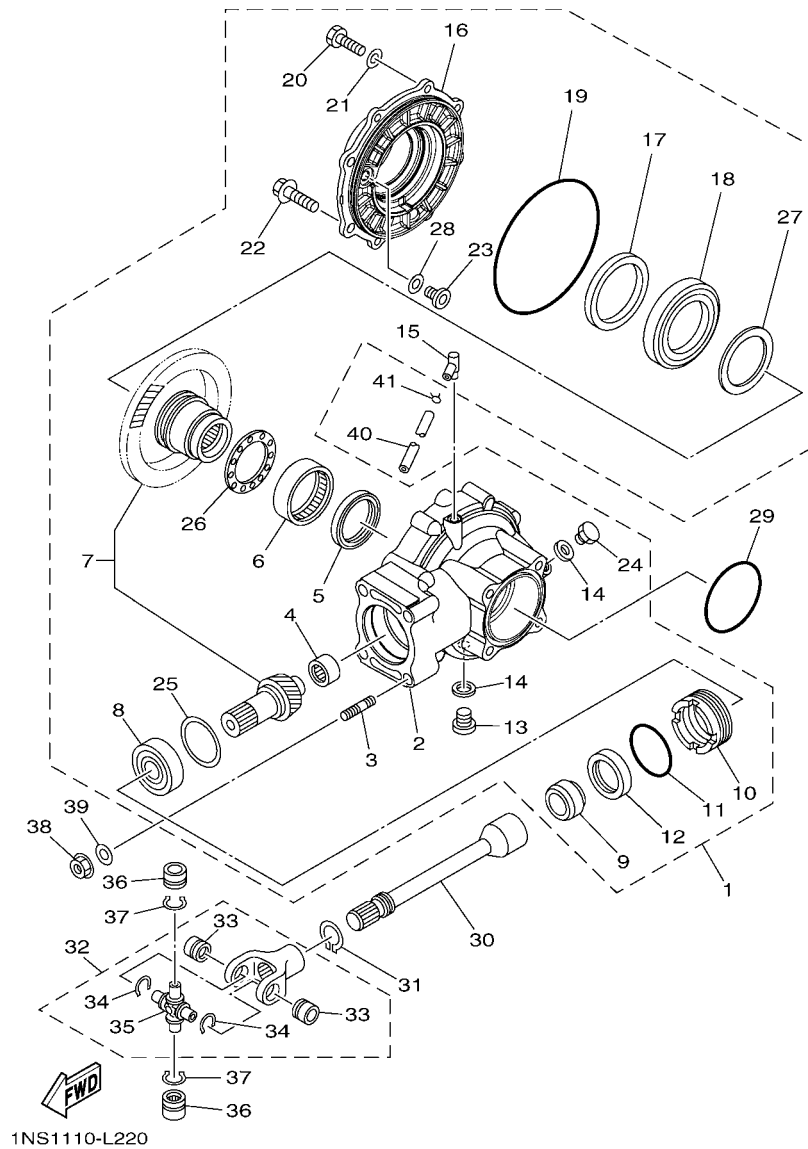

FIG. 22 DRIVE SHAFT

REF. NO.	PART NO.	DESCRIPTION	USA				REMARKS
25	4XE-E7537-45	.SHIM, THRUST(T=0.45MM)	1				UR
	4XE-E7537-50	.SHIM, THRUST(T=0.50MM)	1				UR
	4XE-E7537-60	.SHIM, THRUST(T=0.60MM)	1				UR
26	4XE-G6118-10	.SHIM, THRUST(T=1.0MM)	1				UR
	4XE-G6118-11	.SHIM, THRUST(T=1.1MM)	1				UR
	4XE-G6118-12	.SHIM, THRUST(T=1.2MM)	1				UR
	4XE-G6118-13	.SHIM, THRUST(T=1.3MM)	1				UR
	4XE-G6118-14	.SHIM, THRUST(T=1.4MM)	1				UR
	4XE-G6118-15	.SHIM, THRUST(T=1.5MM)	1				UR
	4XE-G6118-16	.SHIM, THRUST(T=1.6MM)	1				UR
	4XE-G6118-17	.SHIM, THRUST(T=1.7MM)	1				UR
	4XE-G6118-18	.SHIM, THRUST(T=1.8MM)	1				UR
	4XE-G6118-19	.SHIM, THRUST(T=1.9MM)	1				UR
	4XE-G6118-20	.SHIM, THRUST(T=2.0MM)	1				UR
	4XE-G6118-21	.SHIM, THRUST(T=2.1MM)	1				UR
27	4XE-G6117-25	.SHIM, RING GEAR(T=0.25MM)	1				UR
	4XE-G6117-30	.SHIM, RING GEAR(T=0.30MM)	1				UR
	4XE-G6117-35	.SHIM, RING GEAR(T=0.35MM)	1				UR
	4XE-G6117-40	.SHIM, RING GEAR(T=0.40MM)	1				UR
	4XE-G6117-45	.SHIM, RING GEAR(T=0.45MM)	1				UR
	4XE-G6117-50	.SHIM, RING GEAR(T=0.50MM)	1				UR
28	5FU-G6157-10	.SHIM, RING GEAR(T=0.10MM)	1				UR
	5FU-G6157-15	.SHIM, RING GEAR(T=0.15MM)	1				UR
	5FU-G6157-20	.SHIM, RING GEAR(T=0.20MM)	1				UR
	5FU-G6157-30	.SHIM, RING GEAR(T=0.30MM)	1				UR
	5FU-G6157-40	.SHIM, RING GEAR(T=0.40MM)	1				UR
	5FU-G6157-50	.SHIM, RING GEAR(T=0.50MM)	1				UR

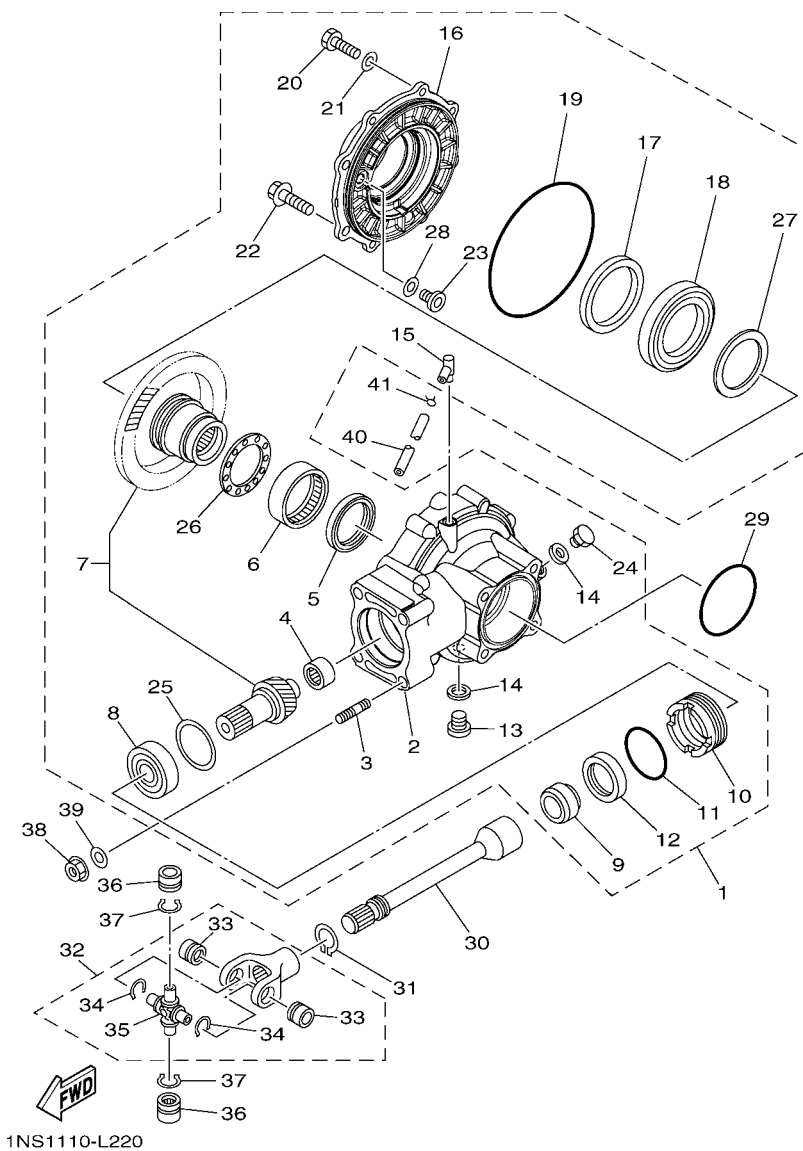

FIG. 22 DRIVE SHAFT

REF. NO.	PART NO.	DESCRIPTION	USA					REMARKS
29	93210-76800	O-RING	1					
30	5ND-G6172-10	SHAFT, DRIVE	1					
31	93410-22039	CIRCLIP	1					
32	3HN-46108-01	CROSS JOINT COMP. 3	1					
33	93399-99926	.BEARING	2					
34	93440-20088	.CIRCLIP	2					
35	2HR-46187-00	.SPIDER	1					
36	93399-99926	BEARING	2					
37	93440-20088	CIRCLIP	2					
38	95702-10500	NUT, FLANGE	4					
39	90201-10036	WASHER, PLATE	4					
40	90445-07810	HOSE (L1050)	1					
41	90467-07029	CLIP	1					



5TE6100-C270

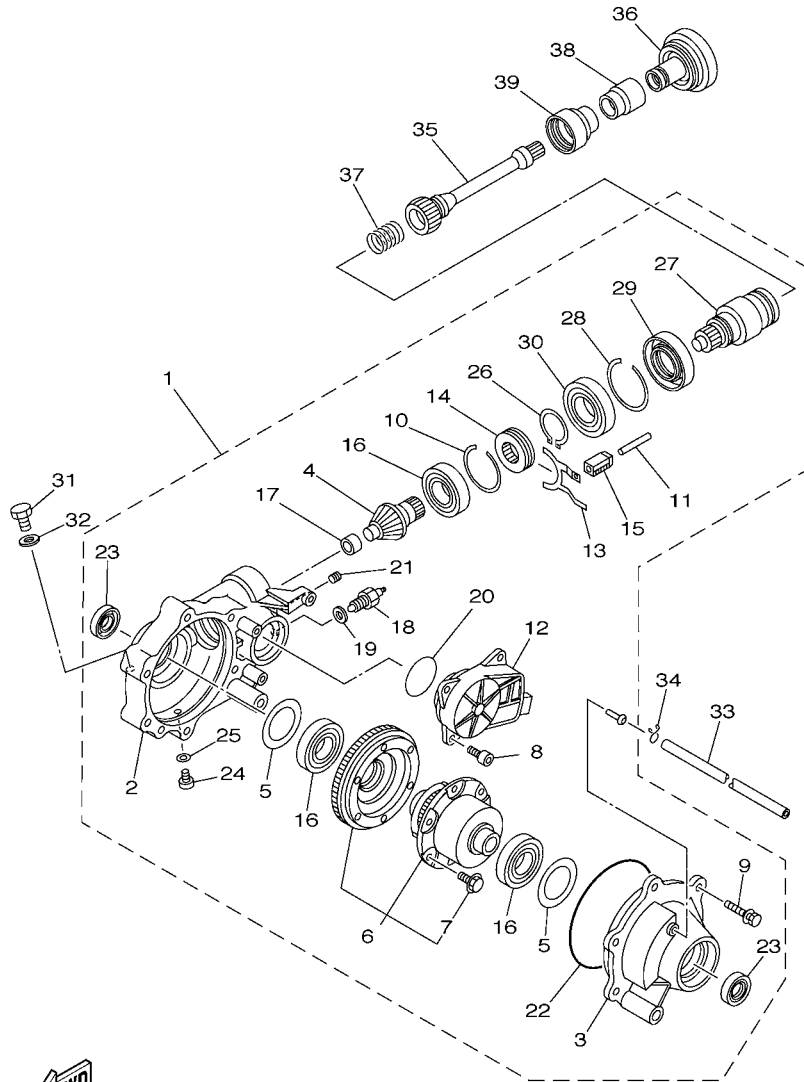

FIG. 23 FRONT DIFFERENTIAL

REF. NO.	PART NO.	DESCRIPTION	USA				REMARKS
1	5GH-46160-05	FRONT AXLE GEAR CASE COMP.	1				
2	5GH-46161-01	.HOUSING, SHAFT DRIVE 2	1				
3	5GH-46162-01	.HOUSING, BEARING 2	1				
4	5GH-46141-01	.PINION, DRIVE 2	1				
5	4WV-46119-01	.SHIM, THRUST (0.1T)	1				UR
4WV-46119-11	.SHIM, THRUST (0.2T)	1					UR
4WV-46119-21	.SHIM, THRUST (0.3T)	1					UR
4WV-46119-31	.SHIM, THRUST (0.4T)	1					UR
4WV-46119-41	.SHIM, THRUST (0.5T)	1					UR
4WV-46119-51	.SHIM, THRUST (1.0T)	1					UR
6	5GH-46470-04	.LIMITED SLIP DIFF. ASSY	1				
7	4WV-46155-00	..BOLT 1	6				
8	91317-08020	.BOLT	3				
9	4WV-46159-00	.BOLT 3	6				
10	4WV-46143-00	.RING,HOLE SNAP 2	1				
11	5GH-18318-00	.SHAFT, SHIFTER	1				
12	5GH-4616A-02	.SERVO MOTOR COMP	1				
13	5GH-18514-01	.FORK, SHIFT 4	1				
14	4WV-46441-00	.CLUTCH,DRIVEN	1				
15	5GH-18319-00	.SHAFT 2	1				
16	4WV-46165-00	.BEARING 2	3				
17	4WV-46167-00	.BEARING 4	1				
18	3GD-82540-11	.NEUTRAL SWITCH ASSY	1				
19	4WV-46132-00	.GASKET 1	1				
20	93210-50768	.O-RING	1				
21	90113-08004	.BOLT, SET	1				
22	93211-40040	.O-RING	1				



5TE6100-C270

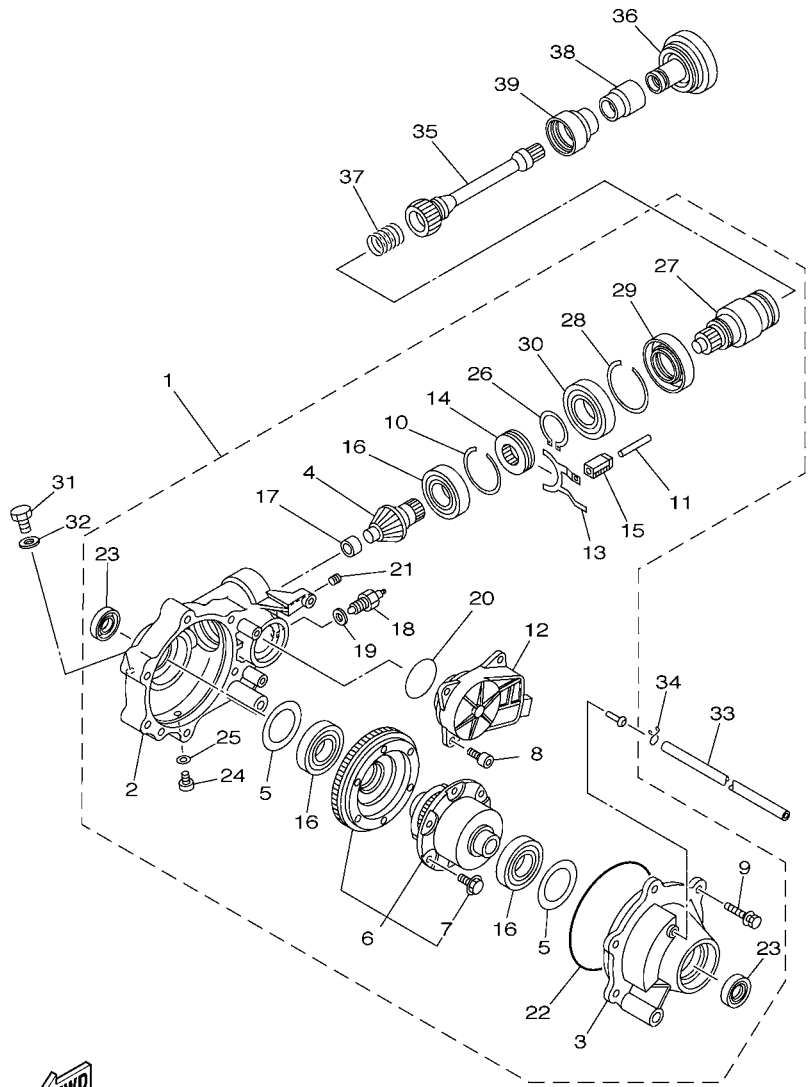
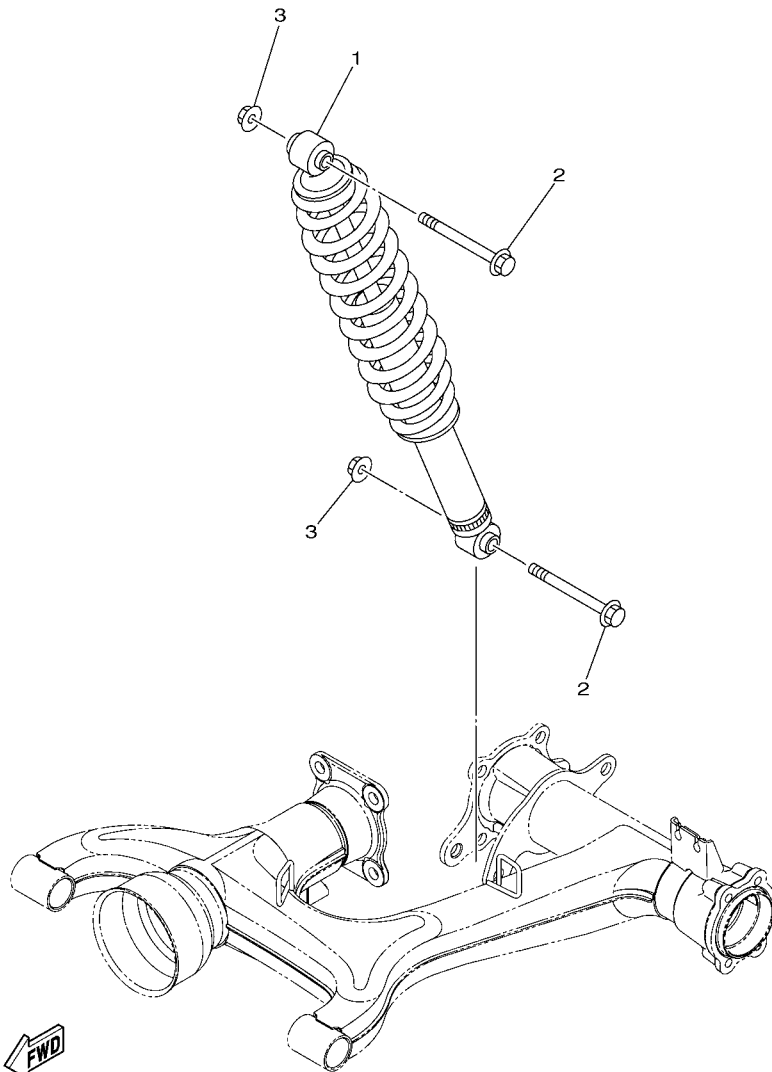

FIG. 23 FRONT DIFFERENTIAL

REF. NO.	PART NO.	DESCRIPTION	USA				REMARKS
23	3B4-46163-00	.SEAL, OIL 1	2				
24	90340-10001	.PLUG, STRAIGHT SCREW	1				
25	90430-10003	.GASKET	1				
26	93450-44141	.CIRCLIP	1				
27	5GH-46126-01	.COUPLING	1				
28	93450-71142	.CIRCLIP	1				
29	5TE-46163-00	.SEAL, OIL 1	1				
30	93316-00801	.BEARING	1				
31	90340-14029	PLUG, STRAIGHT SCREW	1				
32	214-11198-01	GASKET	1				
33	90445-07809	HOSE (L750)	1				
34	90467-07029	CLIP	1				
35	5TE-G6173-10	SHAFT, DRIVE 2	1				
36	5GH-46123-00	COUPLING, GEAR	1				
37	90501-290A1	SPRING, COMPRESSION	1				
38	5GH-46136-00	SEAL 1	1				
39	5KM-46137-00	SEAL 2	1				



1NS1110-L240

FIG. 24 REAR SUSPENSION

REF. NO.	PART NO.	DESCRIPTION	USA				REMARKS
1	1NS-F2210-00	SHOCK ABSORBER ASSY, REAR	1				
2	95812-12080	BOLT, FLANGE	2				
3	90185-12009	NUT, SELF-LOCKING	2				

FIG. 25 FRONT SUSPENSION & WHEEL

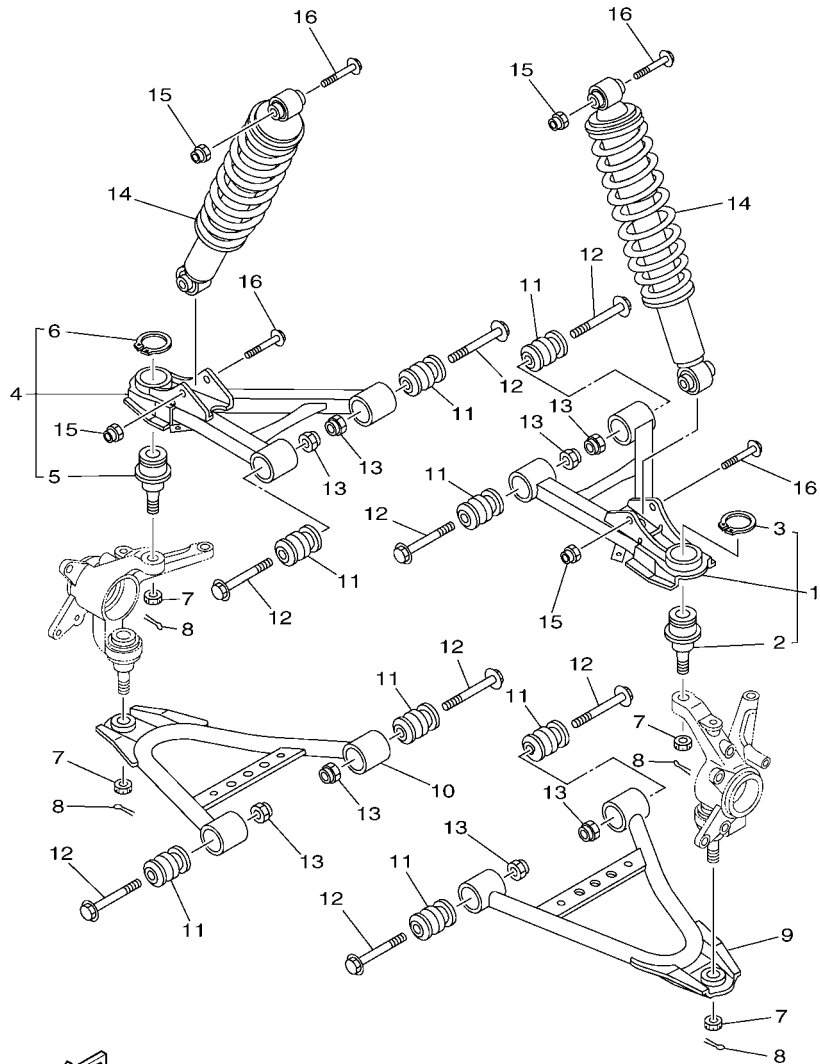

FWD
1NS1110-L250

REF. NO.	PART NO.	DESCRIPTION	USA				REMARKS
1	5ND-F3540-13	FRONT UPPER ARM COMP. (LEFT)	1				
2	37S-23549-01	.BALL JOINT 1	1				
3	99009-32400	.CIRCLIP	1				
4	5ND-F3550-13	FRONT UPPER ARM COMP. (RIGHT)	1				
5	37S-23549-01	.BALL JOINT 1	1				
6	99009-32400	.CIRCLIP	1				
7	90171-12001	NUT, CASTLE	4				
8	91402-25020	PIN, COTTER	4				
9	5ND-F357A-01	ARM,FR. LWR. LH.	1				
10	5ND-F358A-01	ARM,FR. LWR. RH.	1				
11	2HR-23526-00	BUSH	8				
12	95812-10070	BOLT, FLANGE	8				
13	90185-10012	NUT, SELF-LOCKING	8				
14	1NS-F3350-00	SHOCK ABSORBER ASSY	2				
15	90185-10012	NUT, SELF-LOCKING	4				
16	90105-10841	BOLT, FLANGE	4				



1NS1110-L260

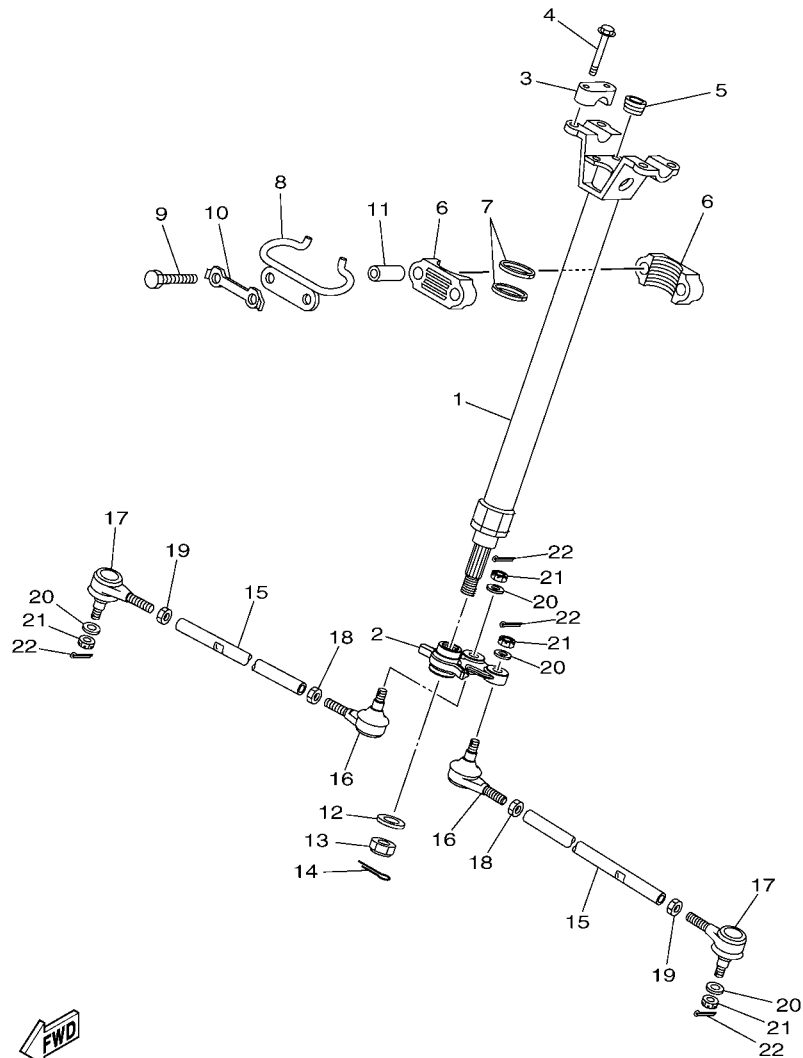
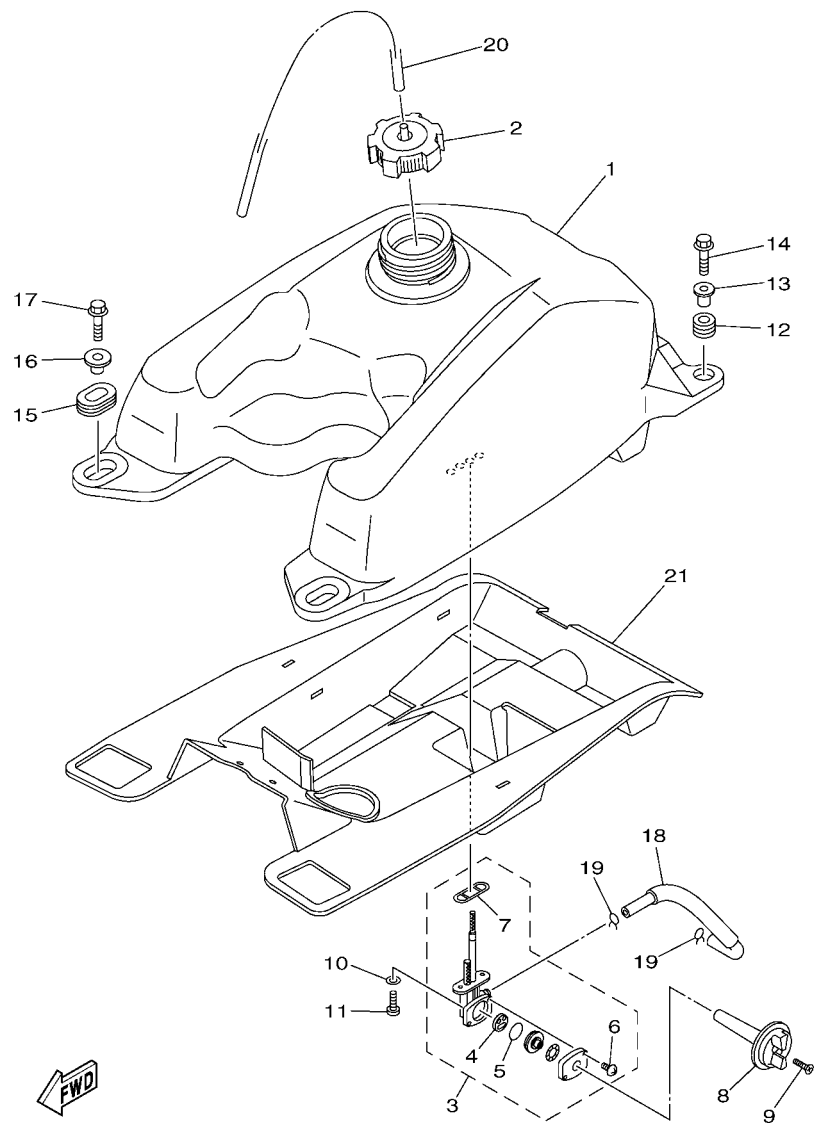

FIG. 26 STEERING

REF. NO.	PART NO.	DESCRIPTION	USA				REMARKS
1	5ND-F3813-10	COLUMN, STEERING 2	1				
2	1NS-F3816-00	ARM, PITMAN	1				
3	8K1-23814-00	HOLDER, HANDLE	2				
4	95812-08030	BOLT, FLANGE	4				
5	90336-28053	PLUG, TAPER	1				
6	37S-F3812-00	BEARING, STEERING	2				
7	93112-31800	OIL SEAL	2				
8	1HP-F3868-00	BRACKET, STEERING LOWER	1				
9	97022-08060	BOLT	2				
10	1UY-23894-01	WASHER, LOCK 1	1				
11	90387-090R0	COLLAR	2				
12	90201-14021	WASHER, PLATE	1				
13	90185-14009	NUT, SELF-LOCKING	1				
14	91402-20025	PIN, COTTER	1				
15	1NS-23831-00	ROD, TIE	2				
16	1UY-23841-01	JOINT, UNIVERSAL 1	2				
17	1UY-23845-01	JOINT, UNIVERSAL 2	2				
18	95302-10700	NUT	2				
19	90170-10010	NUT	2				(L.H. THREAD)
20	90209-10229	WASHER	2				
21	90171-10001	NUT, CASTLE	4				
22	91402-25020	PIN, COTTER	4				



1NS1110-L270

FIG. 27 FUEL TANK

REF. NO.	PART NO.	DESCRIPTION	USA				REMARKS
1	5UH-F4110-10	FUEL TANK COMP.	1				
2	5KM-24610-00	CAP ASSY	1				
3	5KM-24500-10	FUEL COCK ASSY 1	1				
4	3AC-24523-00	.VALVE PACKING	1				
5	3AJ-24534-10	.SEAL, COCK	1				
6	98507-03014	.SCREW, PAN HEAD	2				
7	4X8-24512-10	.GASKET	1				
8	1NS-F4524-00	LEVER, COCK	1				
9	90151-04006	SCREW, COUNTERSUNK	1				
10	90202-05193	WASHER, PLATE	2				
11	90149-06108	SCREW	2				
12	90480-18290	GROMMET	2				
13	90387-066J1	COLLAR	2				
14	95802-06030	BOLT, FLANGE	2				
15	90480-01400	GROMMET	2				
16	90387-07021	COLLAR	2				
17	95802-06030	BOLT, FLANGE	2				
18	5UH-24311-00	PIPE, FUEL 1	1				
19	90467-100A1	CLIP	2				
20	90445-088C5	HOSE (L400)	1				
21	5UH-F414H-01	DAMPENR, PLATE 1	1				

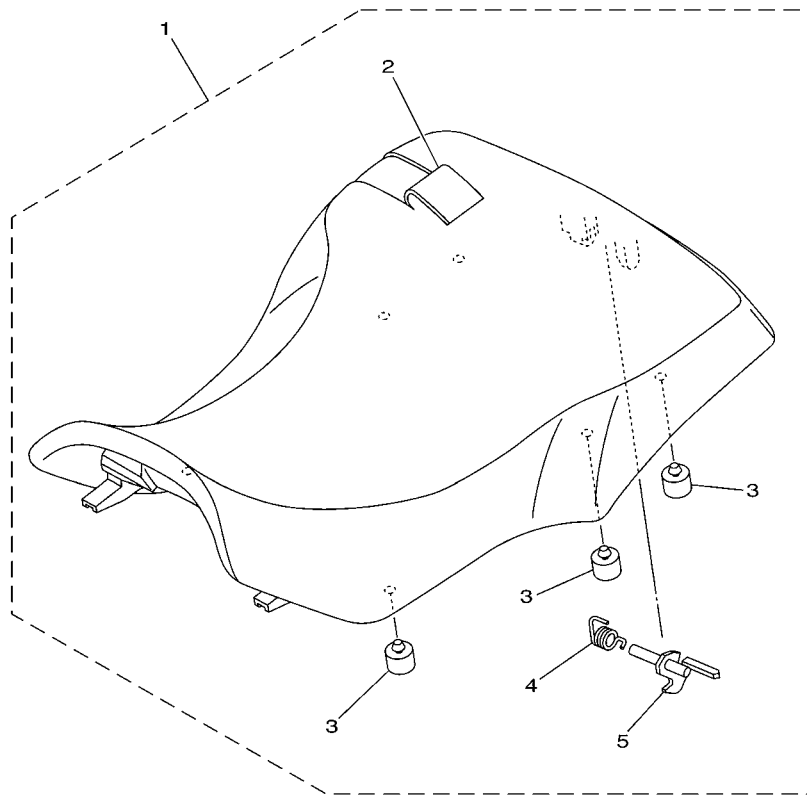

5ND1100-3320

FIG. 28 SEAT

REF. NO.	PART NO.	DESCRIPTION	USA					REMARKS
1	5ND-F4710-04	SINGLE SEAT ASSY	1					
2	5ND-F470F-01	.SEAT COVER COMP.	1					
3	4XE-F4747-00	.DAMPER, SEAT	6					
4	4XE-F478V-00	.SPRING, TORSION	1					
5	5ND-F4776-00	.LEVER, SEAT	1					

FIG. 29 FRONT WHEEL

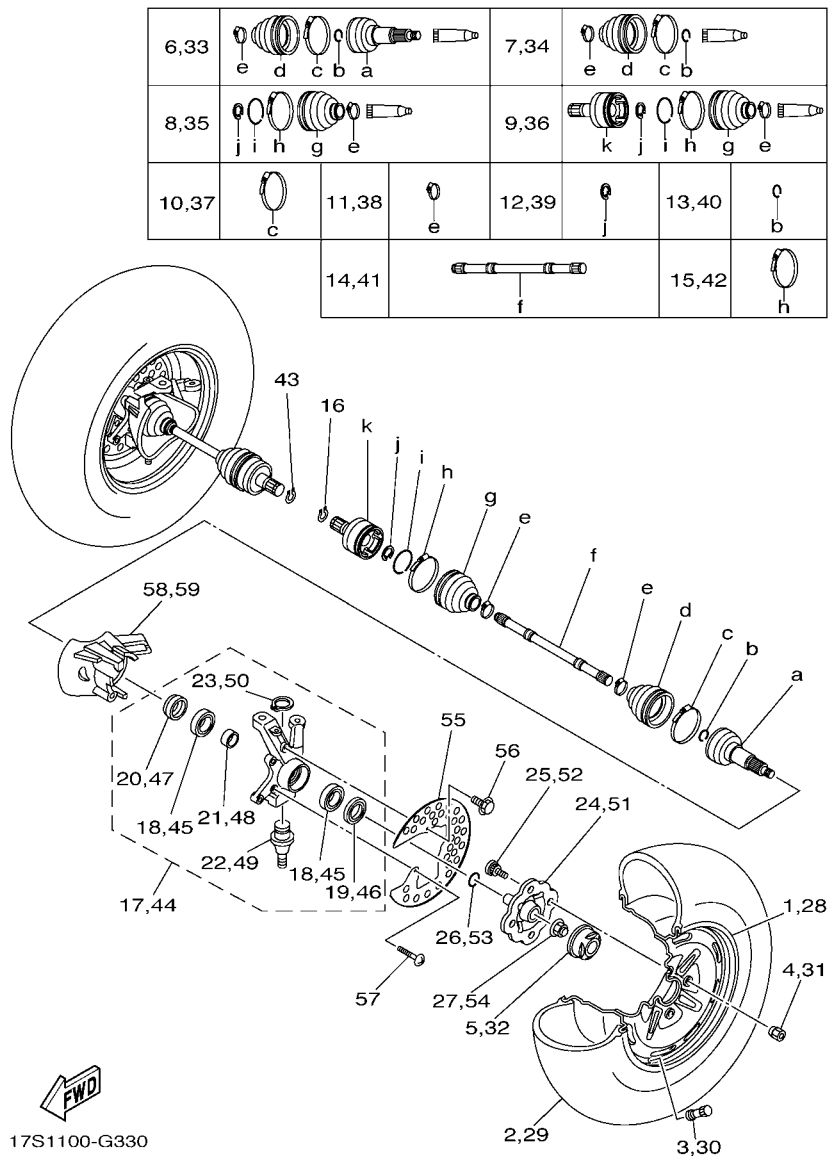

17S1100-G330

REF. NO.	PART NO.	DESCRIPTION	USA				REMARKS
1	1D9-F5180-10	WHEEL COMP.	1				
2	94108-12816	TIRE (AT25X8-12 MU13TL)	1				CHENG SHIN
3	93900-00813	VALVE, RIM (TR413)	1				MAXXIS
4	90179-10022	NUT	4				
5	2P5-F512A-00	CAP, WHEEL	1				
6	4S1-2510F-00	BALL JOINT SET	1				
7	4S1-2510G-00	BOOT SET (BALL JOINT)	1				
8	4S1-2510H-00	BOOT SET(DOUBLE OFFSET JOINT)	1				
9	4S1-2510J-00	DOUBLE OFF SET JOINT	1				
10	3HN-2511G-01	BOOT BAND (BALL JOINT)	1				
11	3HN-2512G-01	BOOT BAND (SMALL)	2				
12	2HR-2512J-00	SNAP RING	1				
13	4KB-2512H-00	CIRCLIP	1				
14	4S1-2511E-01	SHAFT	1				
15	4S1-2511G-00	BOOT BAND	1				
16	93450-22119	CIRCLIP	1				
17	1NS-F3501-00	STEERING KNUCKLE ASSY (LEFT)	1				
18	93306-006Y2	.BEARING	2				
19	93106-38046	.OIL SEAL	1				
20	93106-38047	.OIL SEAL	1				
21	90560-30325	.SPACER	1				
22	37S-23549-01	.BALL JOINT 1	1				
23	99009-32400	.CIRCLIP	1				
24	5ND-F5111-21	HUB, FRONT	1				
25	90114-10014	BOLT, SERRATION	4				
26	93210-27666	O-RING	1				
27	90179-20016	NUT	1				

FIG. 29 FRONT WHEEL

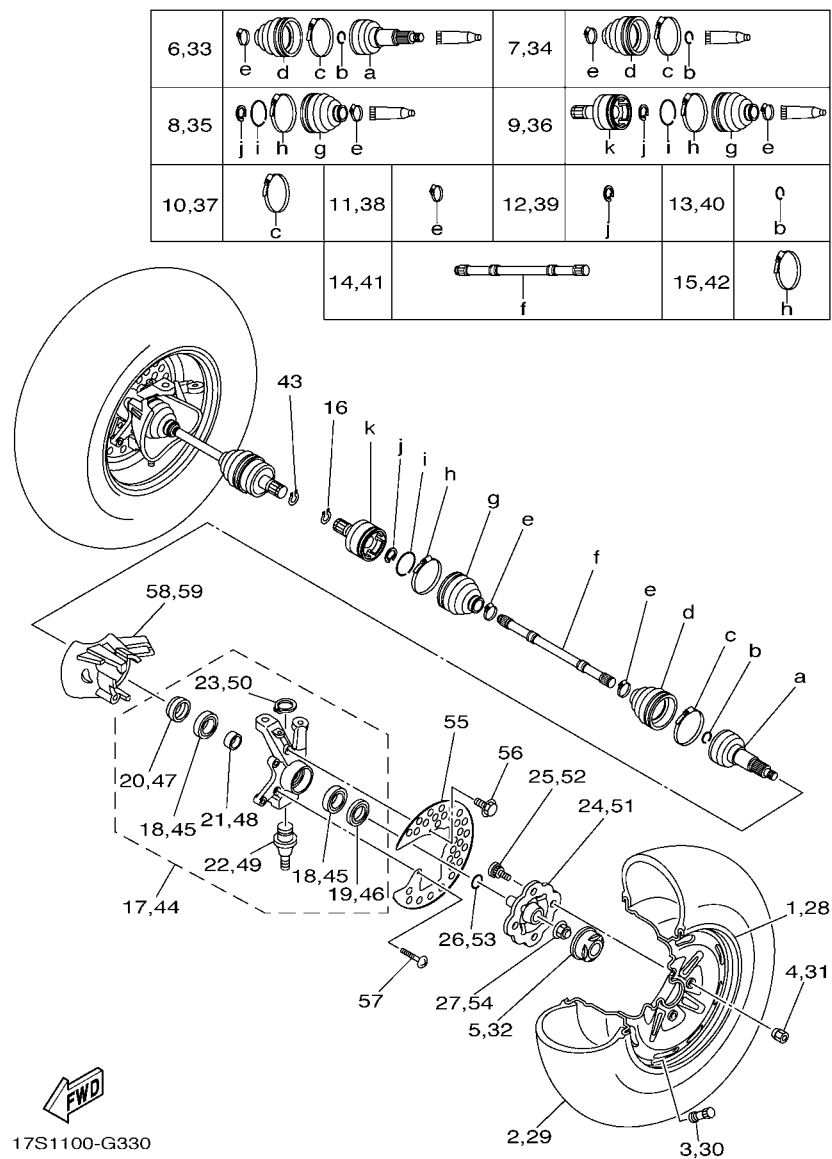

6,33		7,34	
8,35		9,36	
10,37		11,38	
		12,39	
		13,40	
	14,41		15,42

REF. NO.	PART NO.	DESCRIPTION	USA				REMARKS
28	1D9-F5180-10	WHEEL COMP.	1				
29	94108-12816	TIRE (AT25X8-12 MU13TL)	1				CHENG SHIN
30	93900-00813	VALVE, RIM (TR413)	1				MAXXIS
31	90179-10022	NUT	4				
32	2P5-F512A-00	CAP, WHEEL	1				
33	4S1-2510F-00	BALL JOINT SET	1				
34	4S1-2510G-00	BOOT SET (BALL JOINT)	1				
35	4S1-2510H-00	BOOT SET(DOUBLE OFFSET JOINT)	1				
36	4S1-2510J-00	DOUBLE OFF SET JOINT	1				
37	3HN-2511G-01	BOOT BAND (BALL JOINT)	1				
38	3HN-2512G-01	BOOT BAND (SMALL)	2				
39	2HR-2512J-00	SNAP RING	1				
40	4KB-2512H-00	CIRCLIP	1				
41	4S1-2511E-01	SHAFT	1				
42	4S1-2511G-00	BOOT BAND	1				
43	93450-22119	CIRCLIP	1				
44	1NS-F3502-00	STEERING KNUCKLE ASSY (RIGHT)	1				
45	93306-006Y2	.BEARING	2				
46	93106-38046	.OIL SEAL	1				
47	93106-38047	.OIL SEAL	1				
48	90560-30325	.SPACER	1				
49	37S-23549-01	.BALL JOINT 1	1				
50	99009-32400	.CIRCLIP	1				
51	5ND-F5111-21	HUB, FRONT	1				
52	90114-10014	BOLT, SERRATION	4				
53	93210-27666	O-RING	1				
54	90179-20016	NUT	1				

FIG. 29 FRONT WHEEL

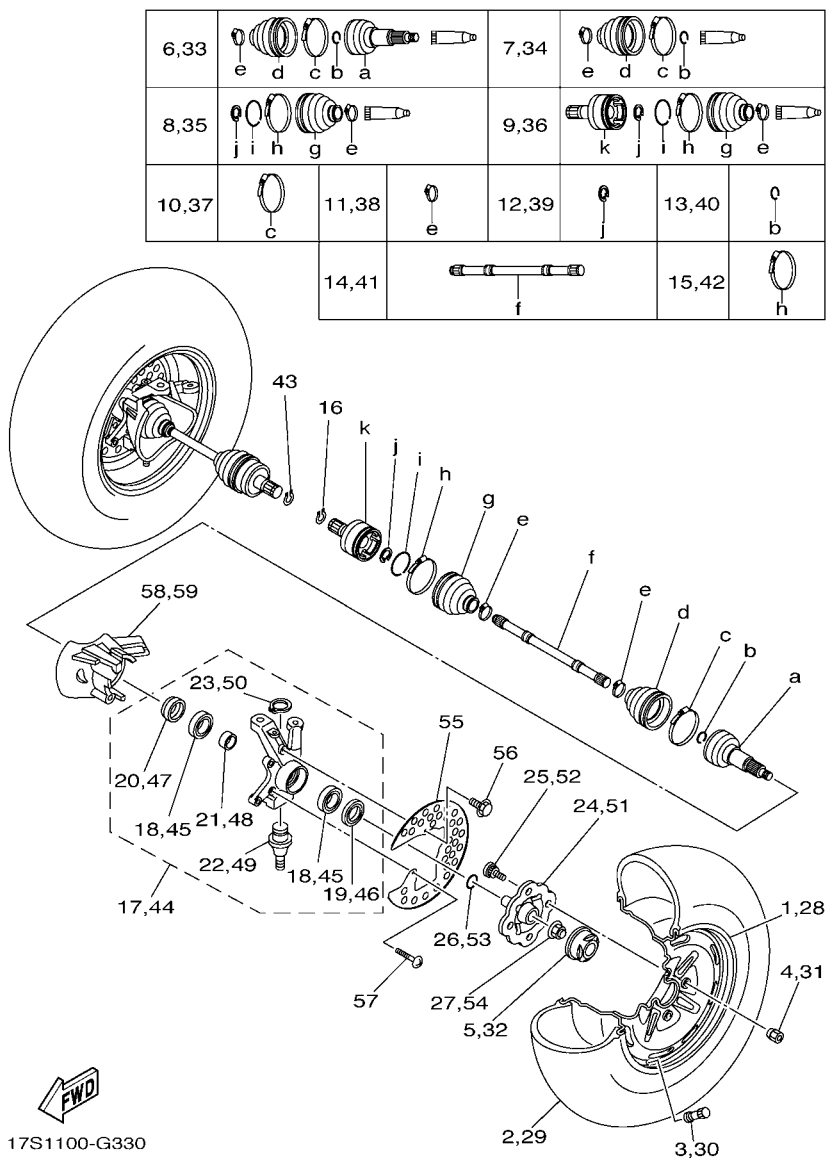

6,33	e d c b a	7,34	e d c b
8,35	j i h g e	9,36	k j i h g e
10,37	c	11,38	e
		12,39	j
		13,40	b
		14,41	f
		15,42	h

REF. NO.	PART NO.	DESCRIPTION	USA				REMARKS
55	5ND-F514A-00	RING, WHEEL 1	2				
56	95812-06012	BOLT, FLANGE	2				
57	90160-05007	SCREW, ROUND TAPPING	2				
58	4S2-F2327-01	MUD GUARD 1	1				LH
59	4S2-F2328-01	MUD GUARD 2	1				RH
<hr/>							
<hr/>							
<hr/>							
<hr/>							
<hr/>							
<hr/>							
<hr/>							
<hr/>							
<hr/>							
<hr/>							
<hr/>							

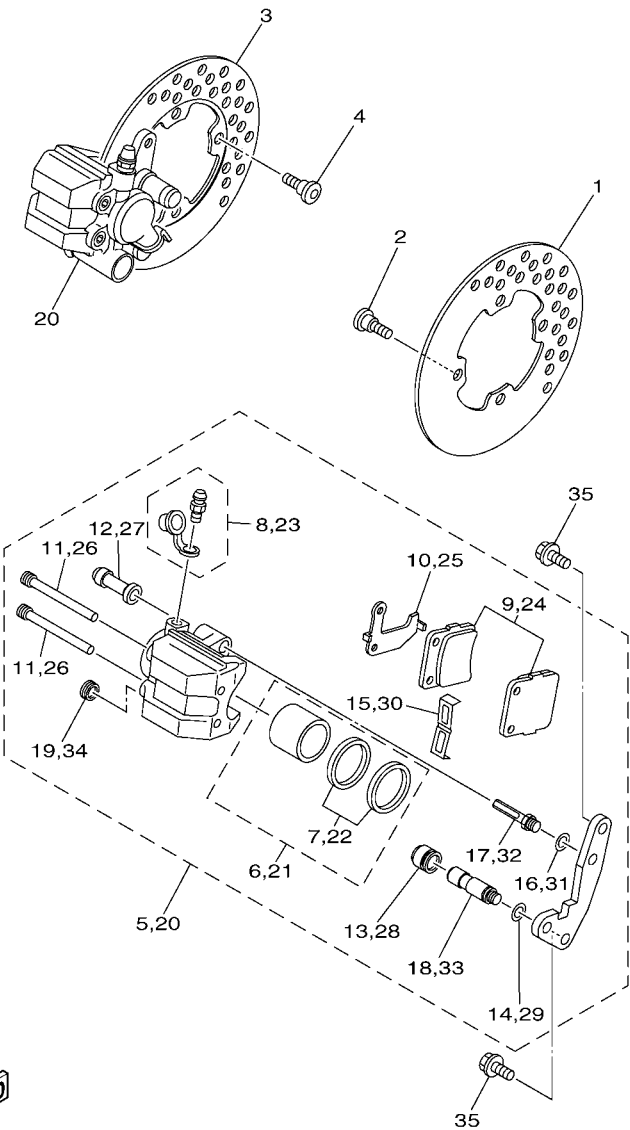

 1CT2100-K330

FIG. 30 FRONT BRAKE CALIPER

REF. NO.	PART NO.	DESCRIPTION	USA				REMARKS
1	5ND-F582T-00	DISC, BRAKE (LEFT)	1				
2	90109-08082	BOLT	4				
3	5ND-F582T-00	DISC, BRAKE (LEFT)	1				
4	90109-08082	BOLT	4				
5	3GD-2580T-01	CALIPER ASSY (LEFT)	1				
6	3GD-W0057-00	.PISTON ASSY, CALIPER	1				
7	3GD-W0047-00	..CALIPER SEAL KIT	1				
8	1UY-W0048-50	.BLEED SCREW KIT	1				
9	3GD-W0045-01	.BRAKE PAD KIT	1				
10	3GD-25827-00	.SHIM, CALIPER	1				
11	3GD-25933-00	.PIN, PAD	2				
12	1UY-25937-51	.BOOT 2	1				
13	1UY-25917-51	.BOOT, CALIPER	1				
14	1UY-25934-51	.SPRING, PAD	1				
15	1UY-25919-51	.SUPPORT, PAD	1				
16	1UY-25938-51	.WASHER, SPRING	1				
17	1UY-25926-51	.BOLT	1				
18	3GD-25914-00	.PIN, SLIDE	1				
19	3GD-25916-00	.PLUG	1				
20	3GD-2580U-01	CALIPER ASSY (RIGHT)	1				
21	3GD-W0057-00	.PISTON ASSY, CALIPER	1				
22	3GD-W0047-00	..CALIPER SEAL KIT	1				
23	1UY-W0048-50	.BLEED SCREW KIT	1				
24	3GD-W0045-01	.BRAKE PAD KIT	1				
25	3GD-25828-00	.SHIM, CALIPER	1				
26	3GD-25933-00	.PIN, PAD	2				
27	1UY-25937-51	.BOOT 2	1				

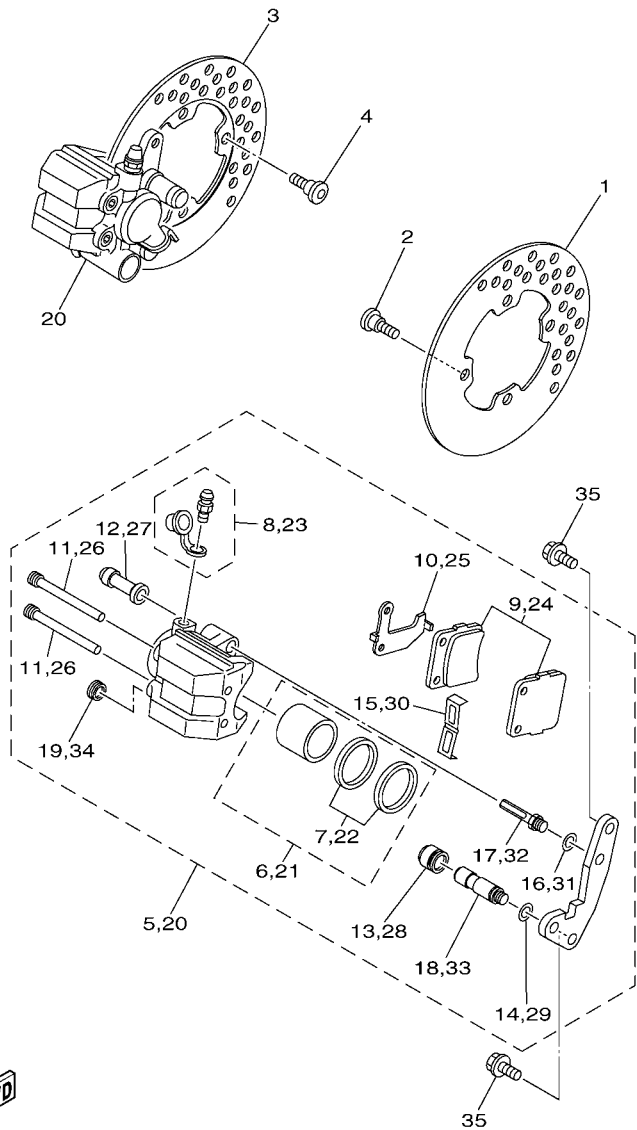

1CT2100-K330

FIG. 30 FRONT BRAKE CALIPER

REF. NO.	PART NO.	DESCRIPTION	USA				REMARKS
28	1UY-25917-51	.BOOT, CALIPER	1				
29	1UY-25934-51	.SPRING, PAD	1				
30	1UY-25919-51	.SUPPORT, PAD	1				
31	1UY-25938-51	.WASHER, SPRING	1				
32	1UY-25926-51	.BOLT	1				
33	3GD-25914-00	.PIN, SLIDE	1				
34	3GD-25916-00	.PLUG	1				
35	90105-08161	BOLT, FLANGE	4				

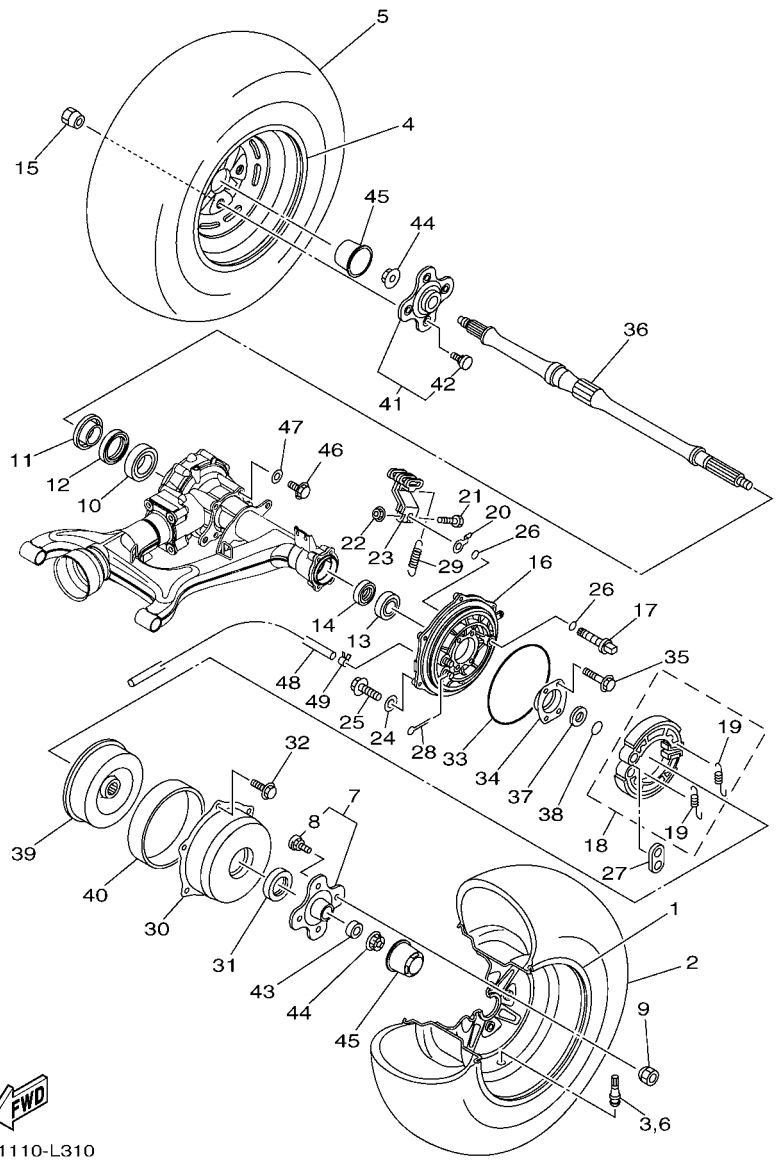

1NS1110-L310

FIG. 31 REAR WHEEL

REF. NO.	PART NO.	DESCRIPTION	USA				REMARKS
1	1NS-F5390-00	REAR WHEEL COMP.	1				
2	94110-12813	TIRE (AT25X10-12 MU14TL)	1				CHENG SHIN
3	93900-00813	VALVE, RIM (TR413)	1				MAXXIS
4	1NS-F5390-00	REAR WHEEL COMP.	1				
5	94110-12813	TIRE (AT25X10-12 MU14TL)	1				CHENG SHIN
6	93900-00813	VALVE, RIM (TR413)	1				MAXXIS
7	1NS-F5183-00	COLLAR, WHEEL	1				
8	1P0-F5411-00	.BOLT	4				
9	90179-10022	NUT	4				
10	93306-008Y0	BEARING	1				
11	4SH-25367-01	COVER, HUB DUST	1				
12	93106-47040	OIL SEAL	1				
13	93306-278Y0	BEARING	1				
14	93101-35097	OIL SEAL	1				
15	90179-10022	NUT	4				
16	5VH-F5321-01	PLATE, BRAKE SHOE	1				
17	5VH-F5351-01	CAMSHAFT	1				
18	5VH-WF536-00	BRAKE SHOE SET	1				
19	5VH-F5333-00	.SPRING, RETURN	2				
20	5VH-F533A-01	PLATE, INDICATOR	1				
21	90101-06824	BOLT	1				
22	9560L-06200	NUT, SELF-LOCKING	1				
23	5VH-F5355-01	LEVER, CAMSHAFT	1				
24	5VH-F5898-00	GASKET	1				
25	5VH-F5818-00	BOLT, CALIPER	1				
26	5VH-F5359-00	SEAL, CAMSHAFT	2				
27	5VH-F539F-01	PLATE 1	1				

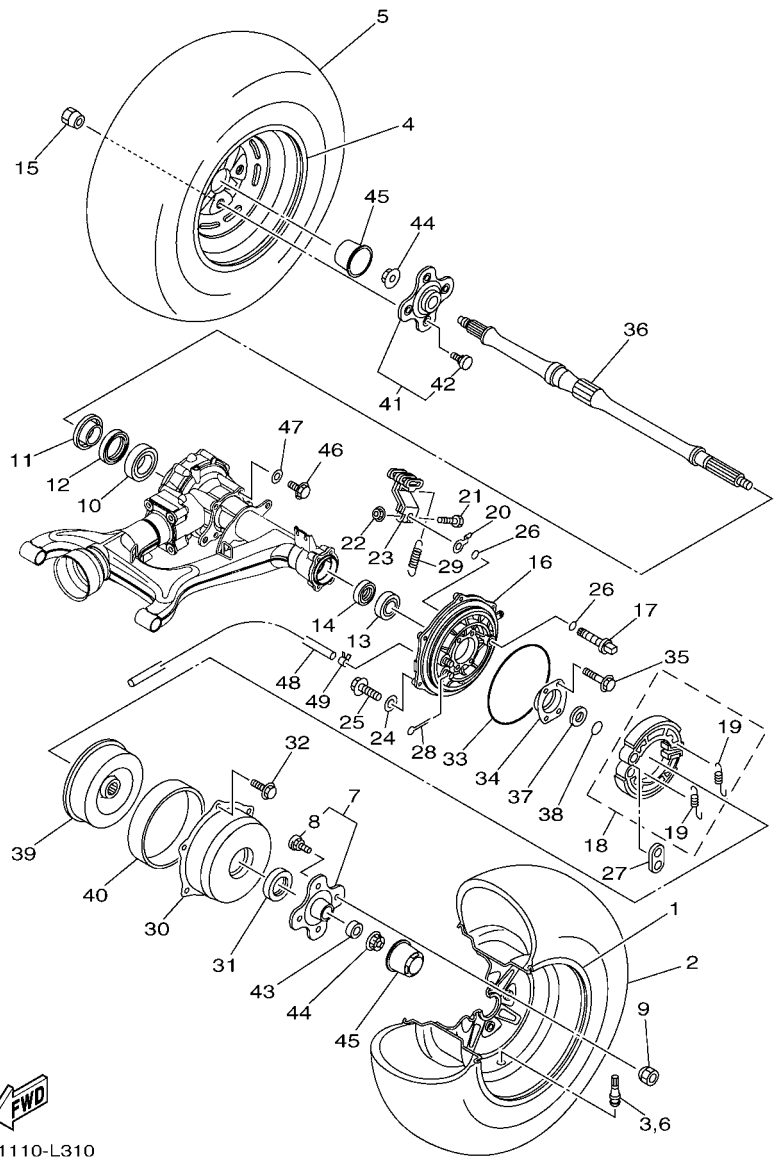

1NS1110-L310

FIG. 31 REAR WHEEL

REF. NO.	PART NO.	DESCRIPTION	USA				REMARKS
28	91402-25020	PIN, COTTER	2				
29	90506-16482	SPRING, TENSION	1				
30	5FU-F5327-01	COVER, PLATE	1				
31	5FU-F5319-10	SEAL, HUB DUST	1				
32	95812-06012	BOLT, FLANGE	6				
33	5FU-F537Y-00	SEAL, DUST	1				
34	4XE-G6513-00	RETAINER	1				
35	90105-088A4	BOLT, FLANGE	4				
36	1NS-F5381-00	AXLE, WHEEL	1				
37	90387-284T0	COLLAR	1				
38	93210-26606	O-RING	1				
39	5FU-F531E-10	DRUM, BRAKE	1				
40	5FU-F5336-00	RING 2	1				
41	1NS-F5186-00	COLLAR, WHEEL	1				
42	1P0-F5411-00	.BOLT	4				
43	1NS-F5384-00	WASHER, WHEEL	1				
44	90179-20016	NUT	2				
45	1NS-F530B-00	WHEEL CAP ASSY.	2				
46	90105-10287	BOLT, FLANGE	4				
47	90201-10035	WASHER, PLATE	4				
48	90445-07807	HOSE (L1150)	1				
49	90467-070A0	CLIP	1				

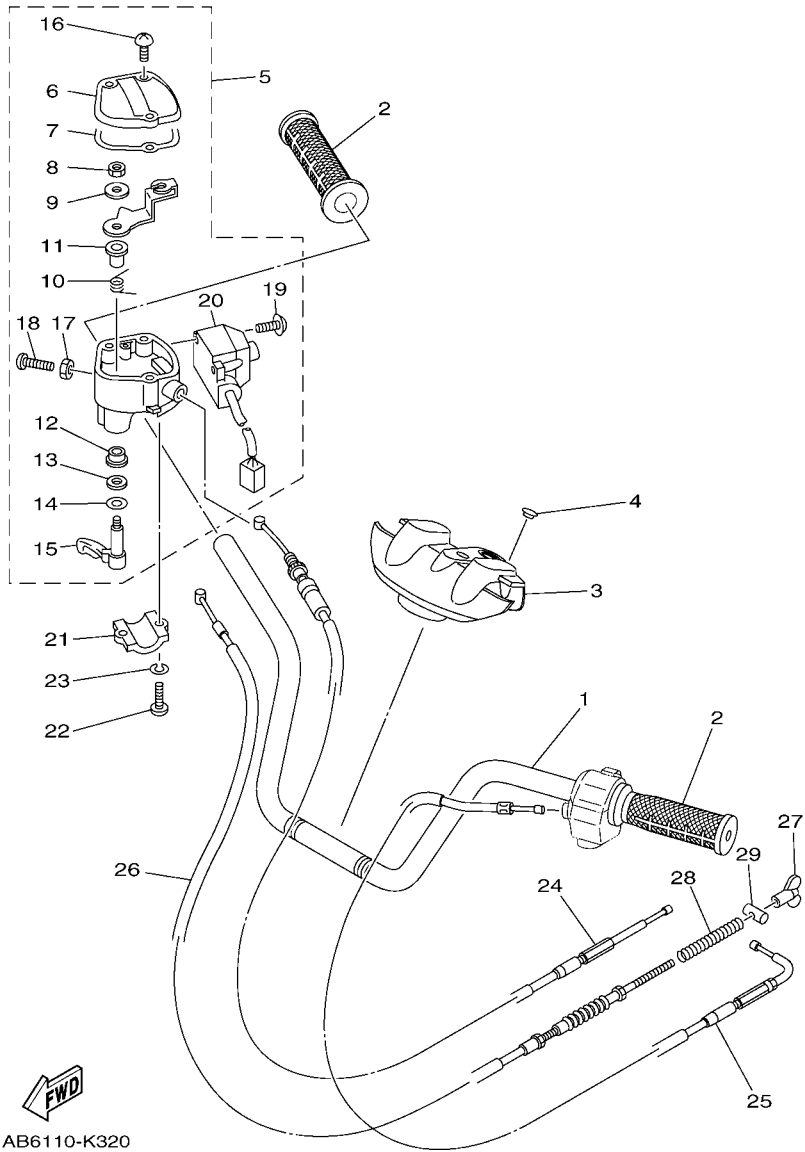

1AB6110-K320

FIG. 32 STEERING HANDLE & CABLE

REF. NO.	PART NO.	DESCRIPTION	USA				REMARKS
1	5FU-F6111-10	HANDLEBAR	1				
2	5FU-F6241-10	GRIP	2				
3	5ND-F6124-01	PROTECTOR, HANDLEBAR	1				
4	90338-14827	PLUG	1				
5	4WV-26250-11	THROTTLE LEVER ASSY	1				
6	4KB-2628F-10	.CAP, GEAR	1				
7	4KB-2628G-00	.GASKET	1				
8	95602-05100	.NUT, U	1				
9	1NV-26398-00	.WASHER	1				
10	1NV-26304-00	.SPRING	1				
11	1NV-26259-01	.COLLAR	1				
12	1NV-2625K-00	.COLLAR	1				
13	93104-09025	.OIL SEAL	1				
14	1NV-26129-00	.WASHER	1				
15	1NV-2625G-01	.LEVER, THROTTLE	1				
16	90149-04278	.SCREW	3				
17	95307-05700	.NUT	1				
18	98507-05020	.SCREW, PAN HEAD	1				
19	97602-04110	.SCREW, PAN HEAD WITH WASHER	2				
20	4WV-83976-00	.SWITCH, HANDLE 1	1				
21	4V4-82913-00	HOLDER, LEVER LOWER 1	1				
22	98502-05020	SCREW, PAN HEAD	2				
23	92902-05600	WASHER, PLATE	2				
24	5GH-26311-10	CABLE, THROTTLE 1	1				
25	5VH-F6331-00	CABLE, STARTER 1	1				
26	1NS-26341-00	WIRE, BRAKE 1	1				
27	20E-26343-00	NUT, ADJUSTING	1				

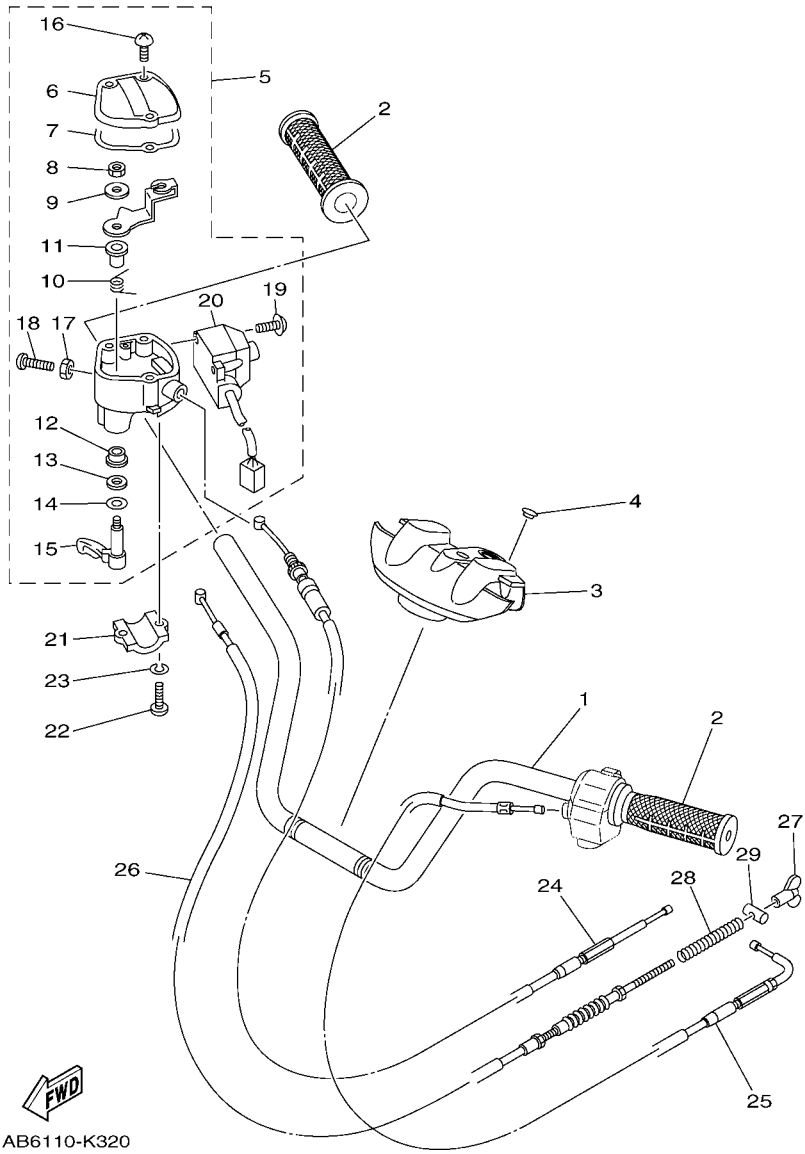
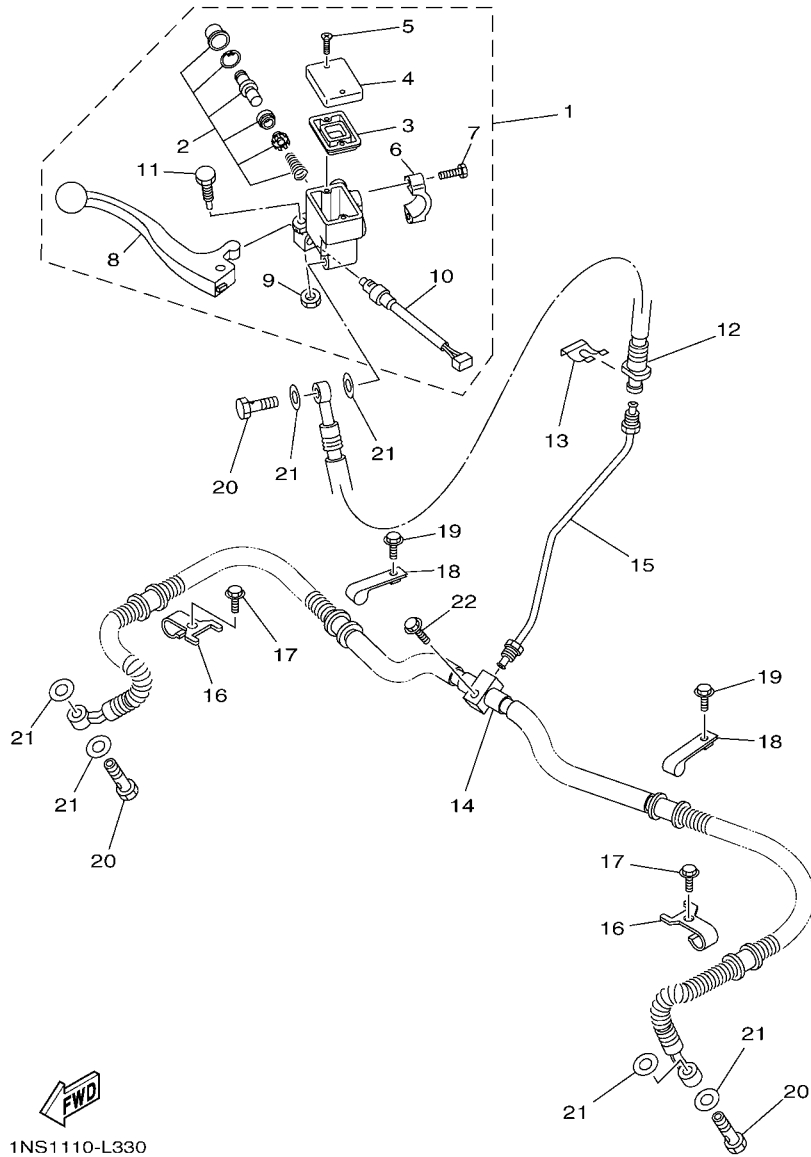

FIG. 32 STEERING HANDLE & CABLE

REF. NO.	PART NO.	DESCRIPTION	USA					REMARKS
28	90501-10782	SPRING, COMPRESSION	1					
29	90249-12008	PIN	1					



1NS1110-L330

FIG. 33 FRONT MASTER CYLINDER

REF. NO.	PART NO.	DESCRIPTION	USA				REMARKS
1	5KM-2583T-10	MASTER CYLINDER ASSY	1				
2	8CR-W0041-00	.CYLINDER KIT, MASTER	1				
3	4L0-25854-00	.DIAPHRAGM, RESERVOIR	1				
4	5LP-25852-02	.CAP, RESERVOIR	1				
5	98702-04012	.SCREW, FLAT HEAD	2				
6	5GM-25867-10	.BRACKET, MASTER CYLINDER	1				
7	5MV-25833-00	.BOLT, FITTING	2				
8	5KM-83922-00	.LEVER 2	1				
9	95701-06500	.NUT, WITH WASHER	1				
10	5LP-83980-00	.FRONT STOP SWITCH ASSY	1				
11	1FK-2589F-10	.BOLT, LEVER	1				
12	5ND-F5872-01	HOSE, BRAKE 1	1				
13	2GU-25866-00	CIRCLIP	1				
14	1NS-F5873-00	HOSE, BRAKE 2	1				
15	5ND-F5871-00	PIPE, BRAKE	1				
16	5ND-F5875-01	HOLDER, BRAKE HOSE 1	2				
17	95812-06012	BOLT, FLANGE	2				
18	5ND-F3192-01	BAND	2				
19	95812-06012	BOLT, FLANGE	2				
20	90401-10015	BOLT, UNION	3				
21	90201-10118	WASHER, PLATE	6				
22	95812-06025	BOLT, FLANGE	1				

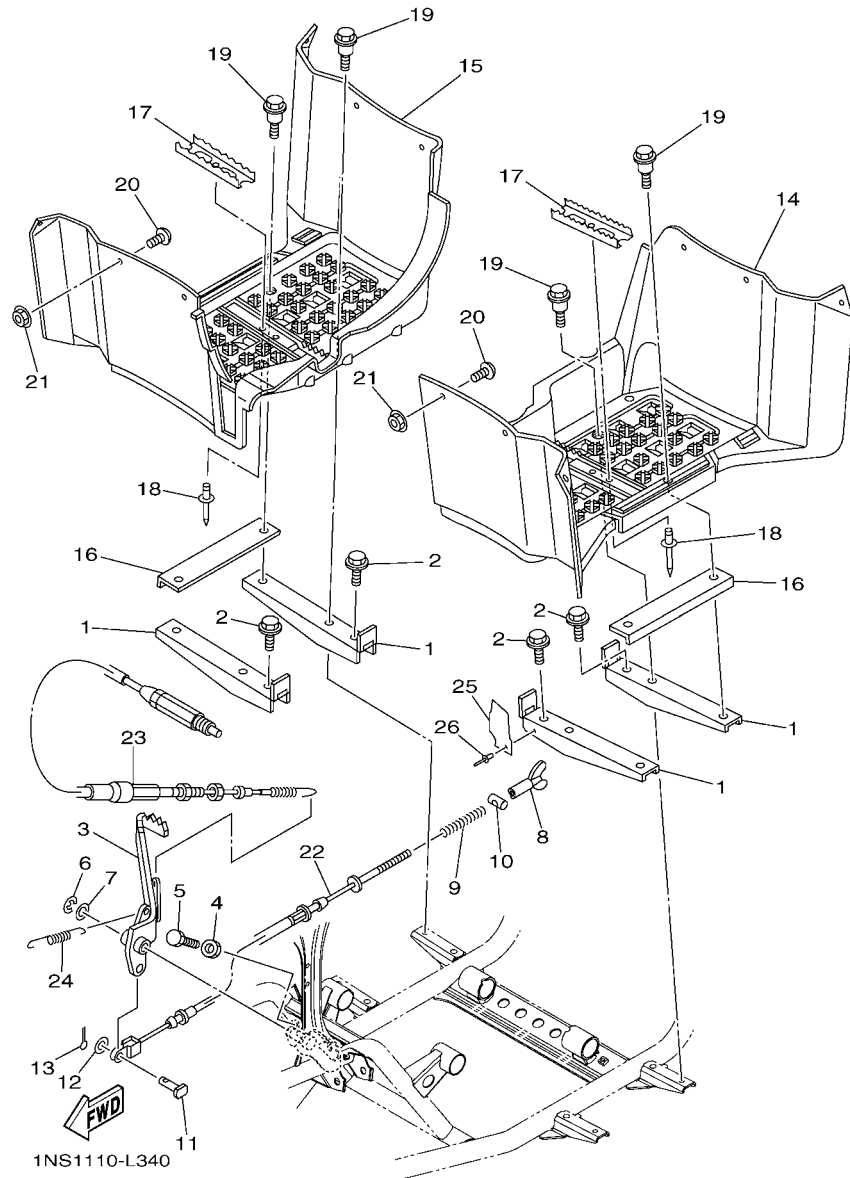
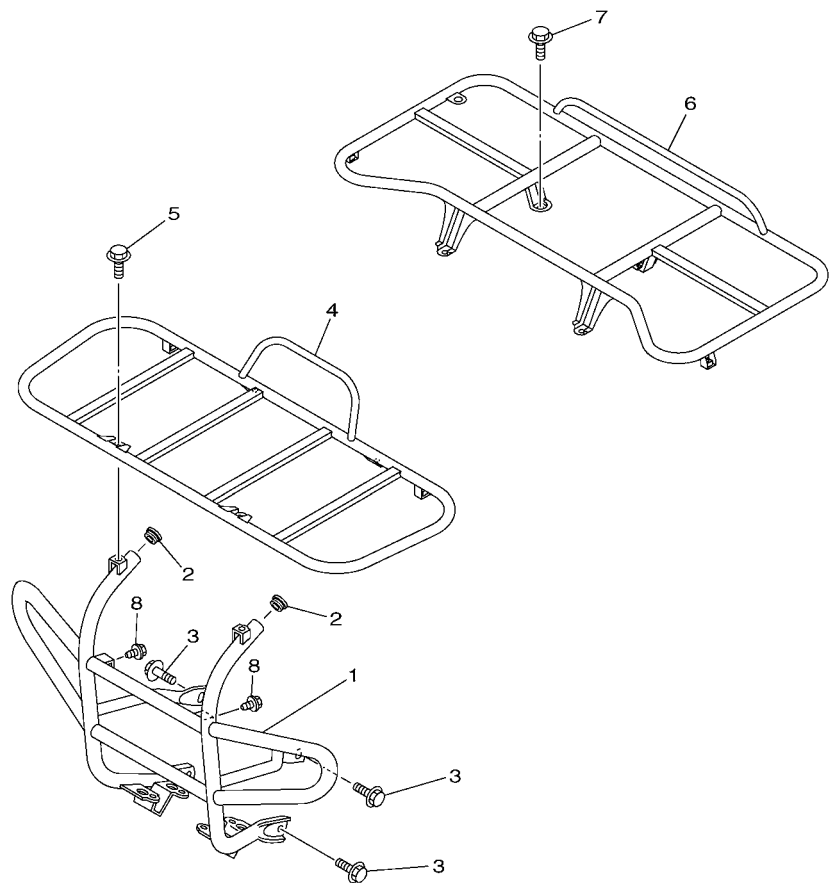

FIG. 34 STAND & FOOTREST

REF. NO.	PART NO.	DESCRIPTION	USA				REMARKS
1	5ND-F7471-01	BAR, FOOTREST 1	4				
2	95812-08012	BOLT, FLANGE	4				
3	5TE-F7211-00	PEDAL, BRAKE	1				
4	95312-06700	NUT	1				
5	97012-06020	BOLT	1				
6	93430-10015	CIRCLIP	1				
7	90201-14023	WASHER, PLATE	1				
8	20E-26343-00	NUT, ADJUSTING	1				
9	90501-10782	SPRING, COMPRESSION	1				
10	90249-12008	PIN	1				
11	90240-08005	PIN, CLEVIS	1				
12	90201-08066	WASHER, PLATE	1				
13	91402-20020	PIN, COTTER	1				
14	5ND-F7453-01	COVER 1	1				
15	5ND-F7463-01	COVER 2	1				
16	5ND-F7445-00	PLATE 1	2				
17	5UH-F741A-10	ARM 1	2				
18	90267-489U9	RIVET, BLIND	2				
19	90109-06262	BOLT	8				
20	90149-05034	SCREW	12				
21	95602-05200	NUT, SELF-LOCKING	12				
22	1NS-26361-00	CABLE, BRAKE	1				
23	5GH-2637F-10	CABLE, CONTROL 2	1				
24	90506-12403	SPRING, TENSION	1				
25	5UH-F7445-01	PLATE 1	1				
26	90267-489U1	RIVET, BLIND	1				



1NS1110-L350

FIG. 35 GUARD

REF. NO.	PART NO.	DESCRIPTION	USA			REMARKS
1	5UH-F845N-00	BAR, CARRY FRONT	1			
2	4XE-F1399-00	CAP	2			
3	95812-08012	BOLT, FLANGE	4			
4	1NS-F4841-00	CARRIER, FRONT	1			
5	95812-08012	BOLT, FLANGE	4			
6	1NS-F4842-00	CARRIER, REAR	1			
7	95812-08012	BOLT, FLANGE	4			
8	90119-06157	BOLT, WITH WASHER	2			

FIG. 36 GENERATOR

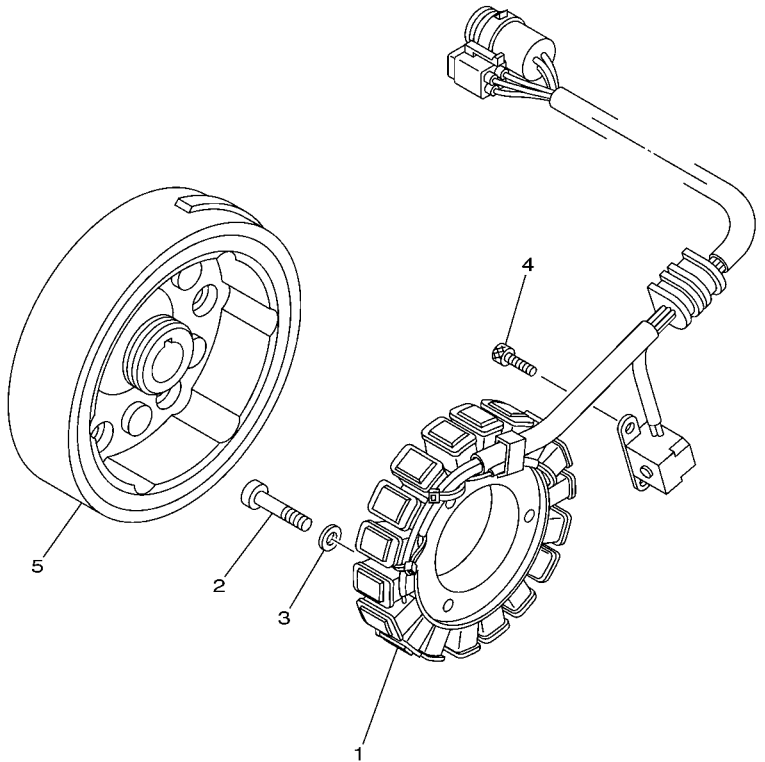

REF. NO.	PART NO.	DESCRIPTION	USA				REMARKS
1	5UH-81410-00	STATOR ASSY	1				
2	92502-06030	SCREW, PAN HEAD	3				
3	92902-06600	WASHER, PLATE	3				
4	91312-05012	BOLT	2				
5	5UH-81450-00	ROTOR ASSY	1				
<hr/>							
<hr/>							
<hr/>							
<hr/>							
<hr/>							
<hr/>							
<hr/>							
<hr/>							
<hr/>							

5UH1100-C370

FIG. 38 METER

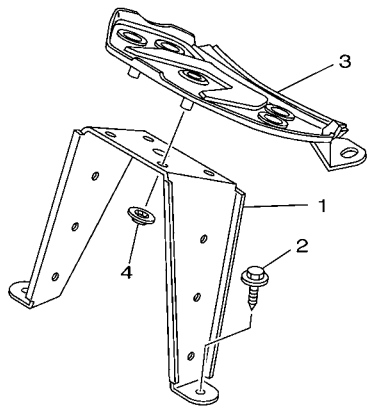

REF. NO.	PART NO.	DESCRIPTION	USA				REMARKS
1	5UH-F5921-00	BRACKET, SUPPORT	1				
2	90119-06157	BOLT, WITH WASHER	2				
3	5UH-F837L-00	PANEL, CONSOLE 1	1				
4	90183-08800	NUT, SPRING	4				

5UH1100-C390

FIG. 39 HEADLIGHT

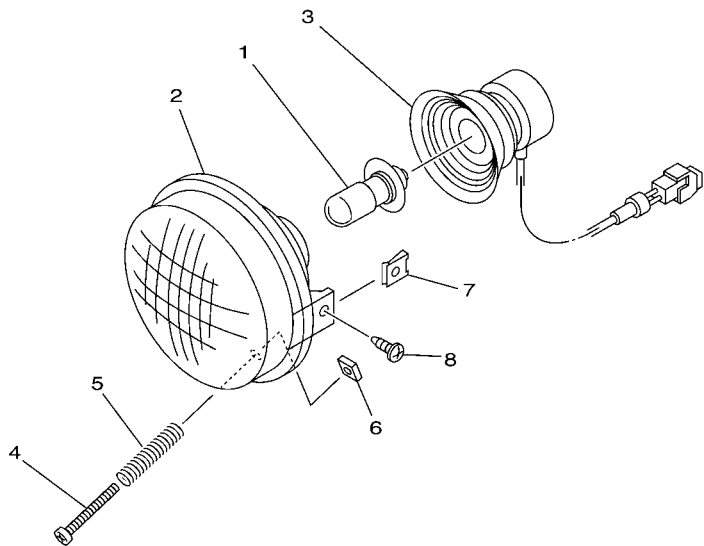

REF. NO.	PART NO.	DESCRIPTION	USA				REMARKS
1	4KB-84314-01	BULB (12V-30/30W)	2				
2	5KM-84320-01	LENS ASSY	2				
3	5EH-84340-00	SOCKET CORD ASSY 1	2				
4	98502-03540	SCREW, PAN HEAD	2				
5	2GU-84332-00	SPRING, SCREW	2				
6	2GU-84334-00	NUT, ADJUSTING	2				
7	90183-05008	NUT, SPRING	4				
8	90154-05021	SCREW, BINDING	4				

 1P01100-D400

FIG. 40 TAILLIGHT

REF. NO.	PART NO.	DESCRIPTION	USA					REMARKS
1	5KM-84710-00	TAILLIGHT UNIT ASSY	1					
2	1A2-84714-41	.BULB (12V-21/5W)	1					
3	5KM-8472C-10	.LENS, TAILLIGHT	1					
4	90201-06097	WASHER, PLATE	2					
5	95702-06300	NUT, NYLON	2					
<hr/>								
<hr/>								
<hr/>								
<hr/>								
<hr/>								
<hr/>								
<hr/>								
<hr/>								
<hr/>								
<hr/>								

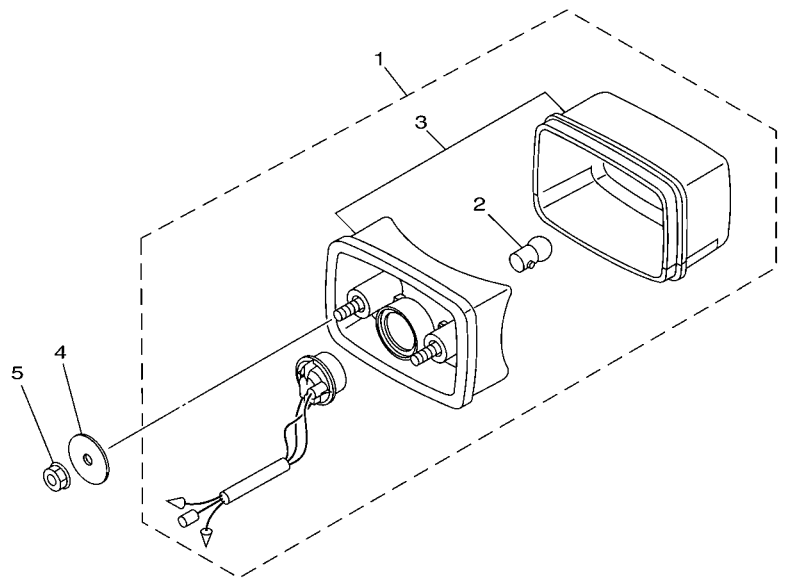

5ND1100-3460

FIG. 41 HANDLE SWITCH & LEVER

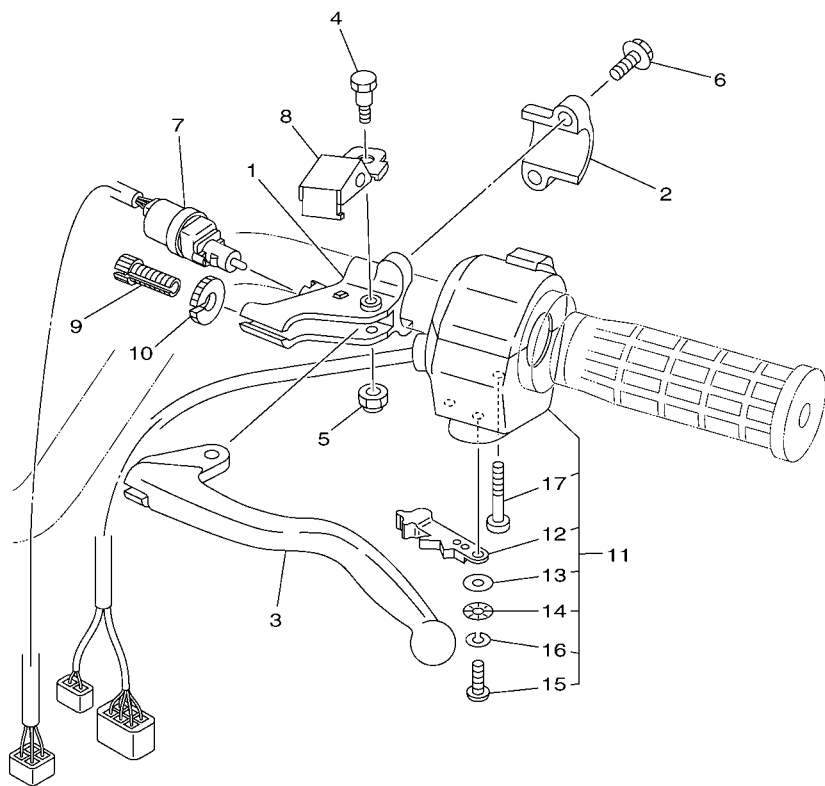

1NS1110-L410

REF. NO.	PART NO.	DESCRIPTION	USA				REMARKS
1	1YW-82911-10	HOLDER, LEVER 1	1				
2	5LP-82913-11	HOLDER, LEVER LOWER 1	1				
3	2HT-83912-00	LEVER 1	1				
4	5FU-2589F-00	BOLT, LEVER	1				
5	95602-06100	NUT, U	1				
6	95022-06020	BOLT, FLANGE	2				
7	3FA-83980-03	FRONT STOP SWITCH ASSY	1				
8	1YW-83965-00	LEVER, LOCK	1				
9	90123-08002	BOLT	1				
10	90179-08030	NUT	1				
11	5LP-83973-01	SWITCH, HANDLE 3	1				
12	5GH-83941-00	.LEVER, STARTER	1				
13	1UY-83909-00	.WASHER, SPECIAL	1				
14	3L4-83943-00	.WASHER, STARTER	1				
15	98517-05012	.SCREW, PAN HEAD	1				
16	92907-05100	.WASHER, SPRING	1				
17	98507-05030	.SCREW, PAN HEAD	2				

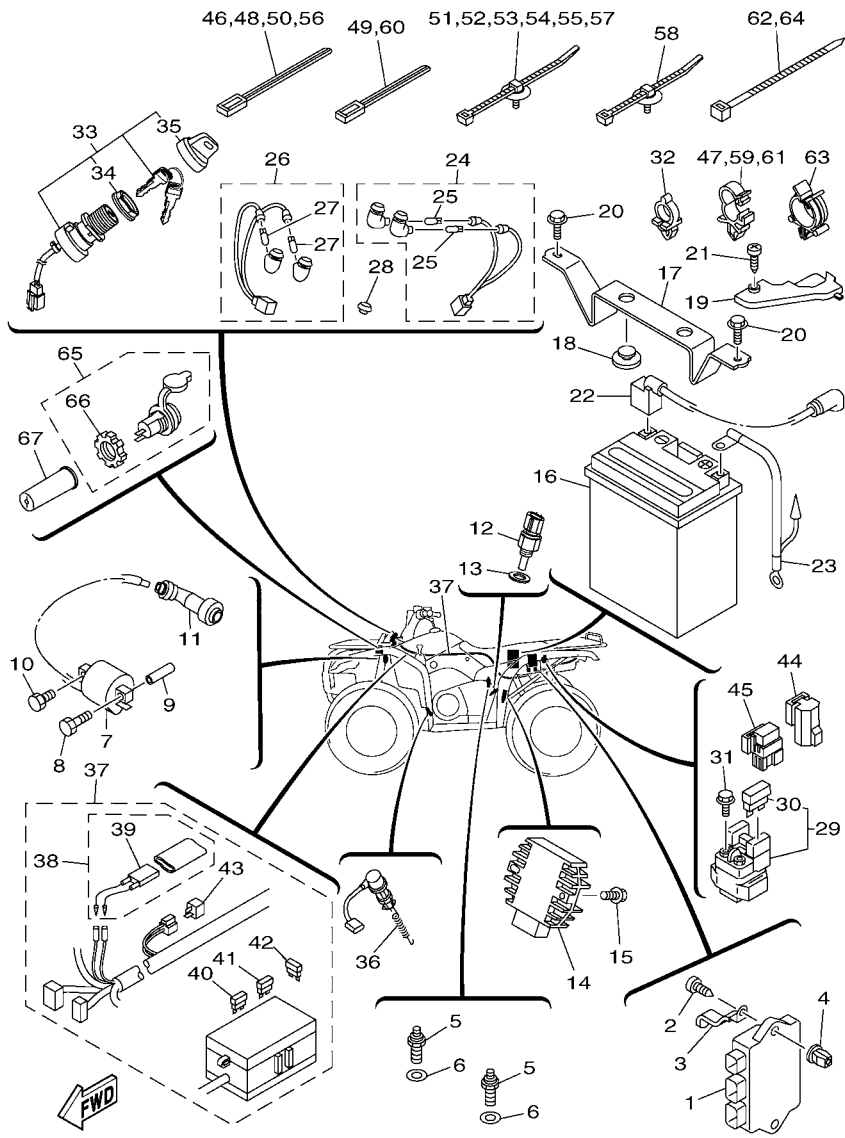

1NS1110-L420

FIG. 42 ELECTRICAL 1

REF. NO.	PART NO.	DESCRIPTION	USA				REMARKS
1	5UH-85540-00	C.D.I. UNIT ASSY	1				
2	97702-60420	SCREW, TAPPING	1				
3	90462-06016	CLAMP	1				
4	90338-08226	PLUG	1				
5	3GB-82540-01	NEUTRAL SWITCH ASSY	2				
6	90430-10148	GASKET	2				
7	5KM-82310-00	IGNITION COIL ASSY	1				
8	90109-06865	BOLT	1				
9	5UH-H1318-00	SPACER	1				
10	95812-06020	BOLT, FLANGE	1				
11	3NS-82370-00	PLUG CAP ASSY	1				
12	4GB-83591-10	THERMO UNIT	1				
13	90201-12172	WASHER, PLATE	1				
14	5GT-81960-00	RECTIFIER & REGULATOR ASSY	1				
15	90105-06833	BOLT, FLANGE	2				
16	5TE-H2100-00	BATTERY ASSY(YUASA YTX14AH)	1				
17	5TE-H2128-01	BRACKET, BATTERY	1				
18	371-82121-00	PAD, BATTERY	2				
19	5ND-H2119-00	COVER, LEAD WIRE	1				
20	90105-06831	BOLT, FLANGE	2				
21	97702-60016	SCREW, TAPPING	1				
22	5TE-H2115-00	WIRE, PLUS LEAD	1				
23	5UH-H2116-00	WIRE, MINUS LEAD	1				
24	5TE-83530-00	PILOT LIGHT ASSY	1				
25	5GH-83516-00	.BULB (12V-1.7W T6.5)	2				
26	5UH-83530-00	PILOT LIGHT ASSY	1				
27	5GH-83516-00	.BULB (12V-1.7W T6.5)	2				

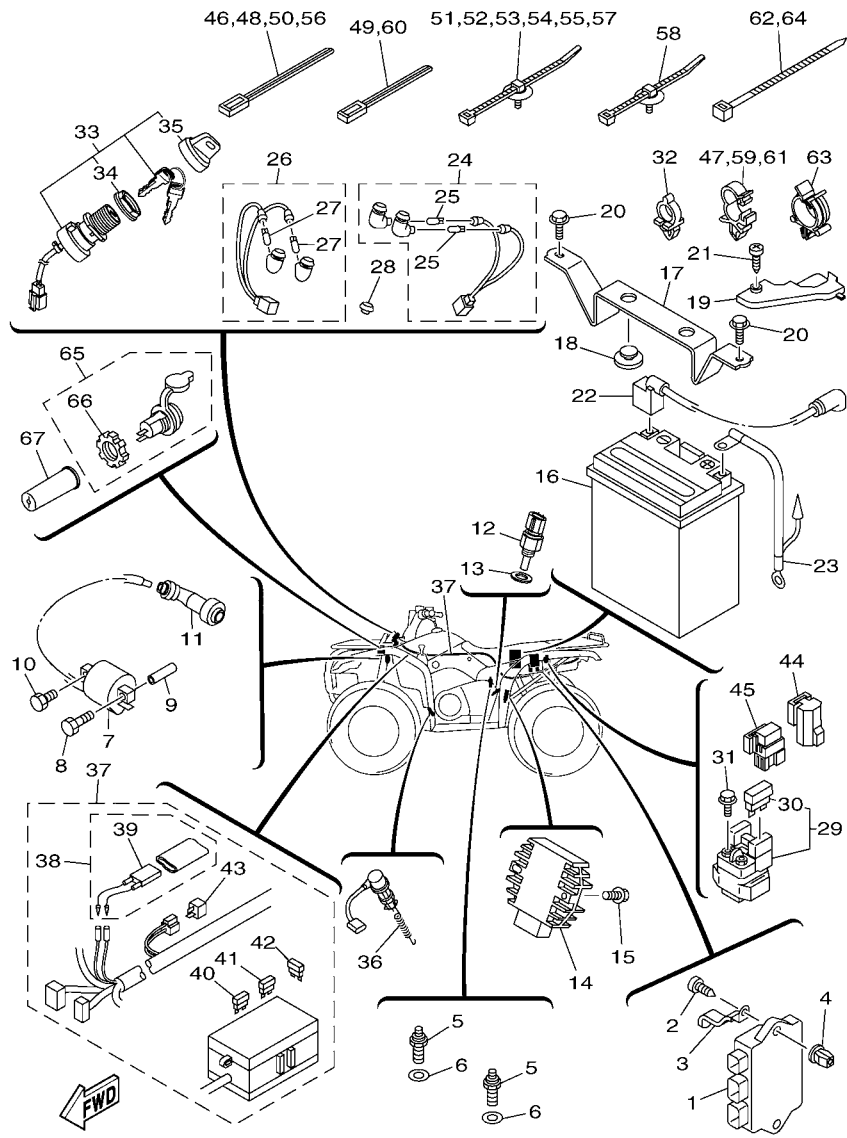

1NS1110-L420

FIG. 42 ELECTRICAL 1

REF. NO.	PART NO.	DESCRIPTION	USA				REMARKS
28	90338-14827	PLUG	1				AP
29	4SV-81940-12	STARTER RELAY ASSY	1				
30	1AE-82151-00	.FUSE (30A-BL)	2				
31	95022-06008	BOLT, FLANGE	2				
32	90464-10833	CLAMP	2				
33	5LP-82510-00	MAIN SWITCH ASSY	1				
	5KM-82510-00	MAIN SWITCH ASSY	1				AP
34	3HN-82569-00	.NUT, MAIN SWITCH	1				
35	3HN-82579-00	.CAP, KEY	1				
36	4KB-82530-10	STOP SWITCH ASSY	1				
37	1NS-82590-00	WIRE HARNESS ASSY	1				
	1NS-82590-10	WIRE HARNESS ASSY	1				AP
38	3D5-82180-00	.CIRCUIT BREAKER ASSY	1				
39	3D5-82560-00	..THERMO SWITCH ASSY	1				
40	5JJ-82151-10	.FUSE (15A-BL)	3				
41	5JJ-82151-30	.FUSE (10A-BL)	2				
42	5JJ-82151-50	.FUSE (3A-BL)	2				
43	3WP-81980-00	.DIODE ASSY	1				
44	29U-81950-93	RELAY ASSY	1				
45	5DM-81950-00	RELAY ASSY (G8HN-1C4T-DJ-Y52)	1				
46	90464-40825	CLAMP	1				
47	90464-12830	CLAMP	1				d: 12mm
48	90464-40825	CLAMP	1				
49	90464-31827	CLAMP	4				122X4.80
50	90464-40825	CLAMP	4				
51	5B4-F1338-00	CLAMP	3				
52	5B4-F1338-00	CLAMP	3				

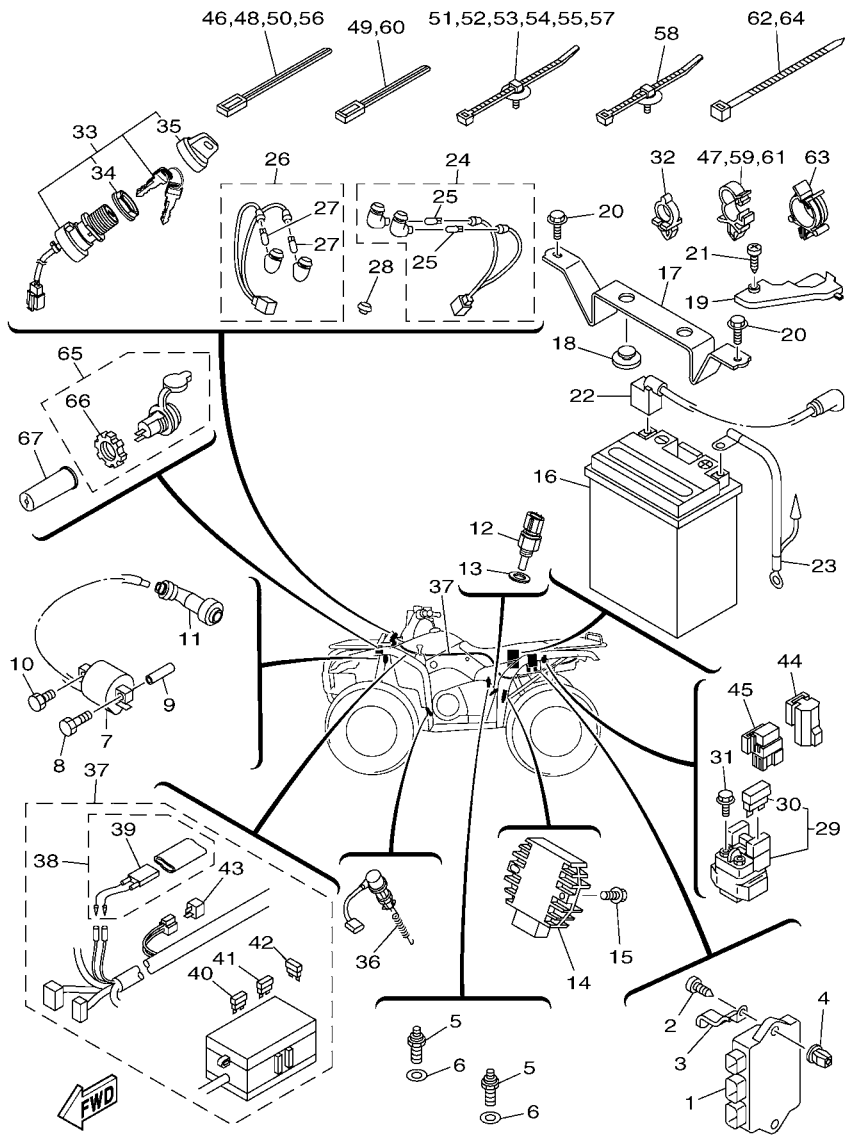

1NS1110-L420

FIG. 42 ELECTRICAL 1

REF. NO.	PART NO.	DESCRIPTION	USA				REMARKS
53	5B4-F1338-00	CLAMP	2				
54	5B4-F1338-00	CLAMP	2				
55	5B4-F1338-00	CLAMP	2				
56	90464-40825	CLAMP	2				
57	5B4-F1338-00	CLAMP	1				
58	1NS-F1338-00	CLAMP	1				
59	90464-12830	CLAMP	2				d: 12mm
60	90464-31827	CLAMP	1				122X4.80
61	90464-12830	CLAMP	1				d: 12mm
62	90464-48800	CLAMP	3				
63	90464-25826	CLAMP	1				
64	90464-48800	CLAMP	1				
65	5FU-H1920-10	TERMINAL ASSY	1				AP
66	5FU-H191B-10	.NUT	1				AP
67	5FU-H2599-01	COVER, CONNECTER	1				AP

FIG. 43 GRAPHICS

REF. NO.	PART NO.	DESCRIPTION	USA				REMARKS
1	3B4-26232-01	EMBLEM 3D	1				
2	1NS-F1788-00	GRAPHIC	2				
3	5UG-F153A-70	EMBLEM, YAMAHA	2				

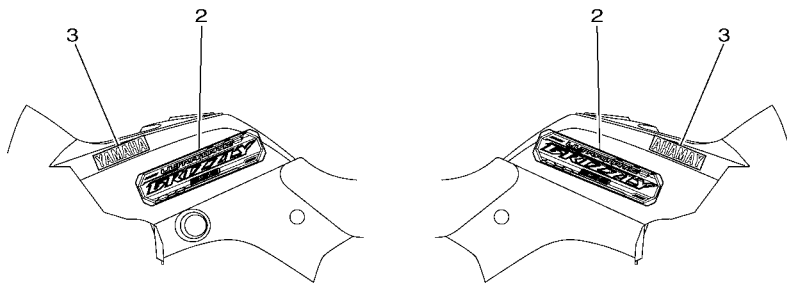
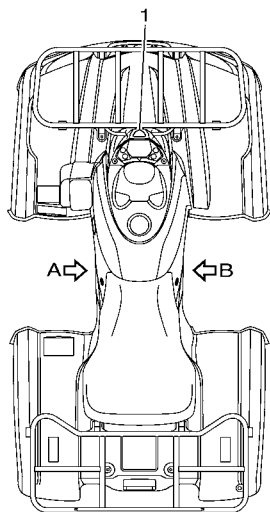

VIEW A

VIEW B

1NS1110-L430

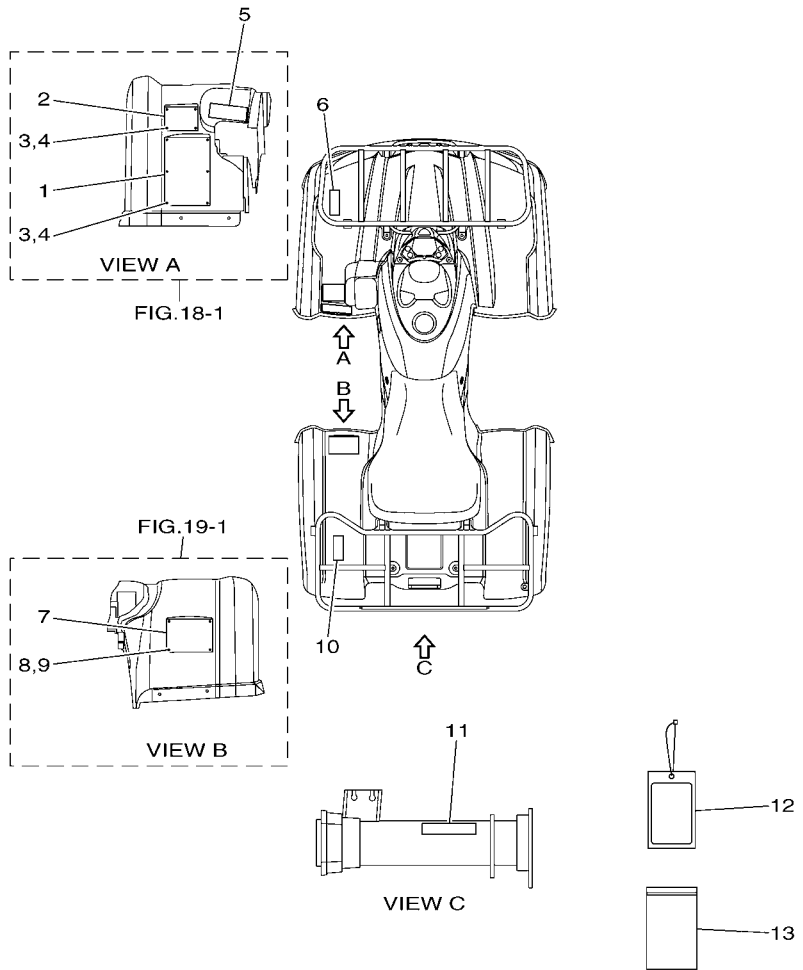

1NS1110-L440

FIG. 44 EMBLEM & LABEL 1

REF. NO.	PART NO.	DESCRIPTION	USA				REMARKS
1	4XE-F1568-00	LABEL, WARNING	1				ENGLISH
2	1P0-F816L-00	LABEL, WARNING AGE	1				ENGLISH
3	4XE-F1539-10	RIVET	10				
4	4XE-F1549-00	WASHER, FENDER MOLD	10				
5	5TE-F151E-00	LABEL 2	1				ENGLISH
6	5ND-F4877-30	LABEL, CAUTION	1				ENGLISH
7	5FU-F816M-00	LABEL, WARNING TIRE & LOAD	1				ENGLISH
8	4XE-F1539-10	RIVET	4				
9	4XE-F1549-00	WASHER, FENDER MOLD	4				
10	5ND-F4897-30	EMBLEM	1				ENGLISH
11	5ND-F151K-00	LABEL 7	1				ENGLISH
12	4XE-F819R-20	TAG, WARNING	1				
13	1P0-F8186-01	POUCH	1				

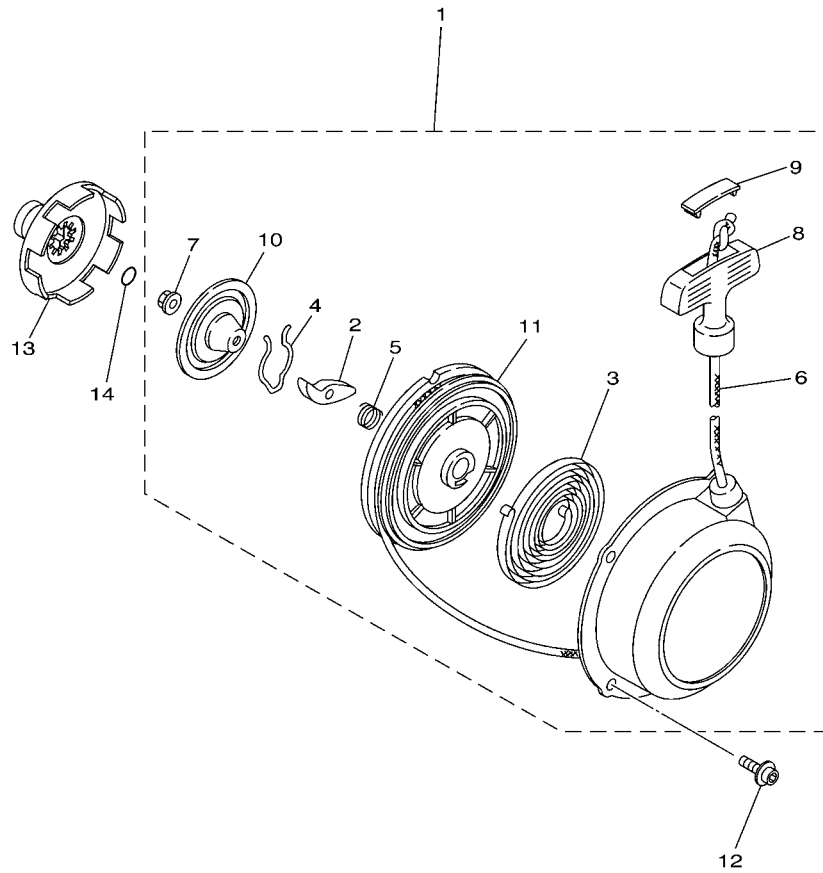

 5UHG100-F120

FIG. 45 ALTERNATE FOR ENGINE

REF. NO.	PART NO.	DESCRIPTION	USA				REMARKS
1	5UH-15710-00	STARTER ASSY	1				AP
2	21V-15741-00	.PAWL, DRIVE	1				
3	5UH-15713-00	.SPRING, STARTER	1				
4	21V-15715-01	.SPRING, FRICTION	1				
5	21V-15767-00	.SPRING	1				
6	21V-15751-00	.WIRE, STARTER	1				
7	95702-06500	.NUT, FLANGE	1				
8	3X3-15755-00	.HANDLE, STARTER	1				
9	21V-15779-00	.COVER	1				
10	5UH-15716-00	.PLATE, DRIVE	1				
11	24W-15714-00	.DRUM, SHEAVE	1				
12	90110-06285	BOLT, HEXAGON SOCKET HEAD	4				AP
13	5KM-15723-00	PULLEY, STARTER	1				AP
14	93210-16290	O-RING	1				AP

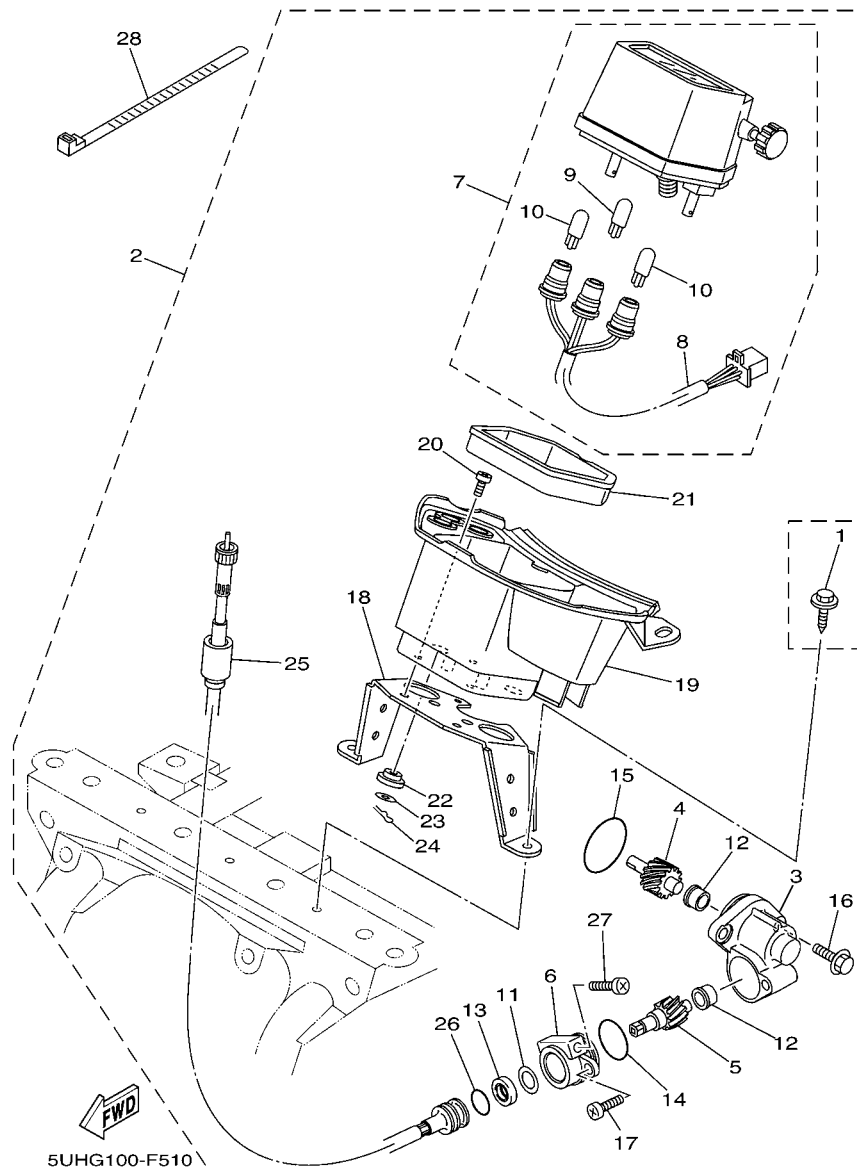

FIG. 46 ALTERNATE FOR METER

REF. NO.	PART NO.	DESCRIPTION	USA				REMARKS
1	90119-06157	BOLT, WITH WASHER	2				
2	1NS-W0081-00	SPEEDOMETER KIT	1				AP
3	4WV-17811-00	.HOUSING, TACHOMETER GEAR	1				
4	4WV-17831-00	.GEAR, DRIVE	1				
5	4WV-17841-00	.GEAR, DRIVEN	1				
6	59V-17811-00	.HOUSING, TACHOMETER GEAR	1				
7	12S-83570-00	.SPEEDOMETER ASSY	1				(MPH MODEL)
8	4SH-83536-10	..SOCKET, METER	1				
9	42X-83517-00	..BULB (12V-3W)	1				
10	2GV-83517-00	..BULB (12V-1.7W T6.5)	2				
11	90201-12M34	.WASHER, PLATE	1				
12	90381-08002	.BUSH, SOLID	2				
13	93102-08307	.OIL SEAL	1				
14	93210-24253	.O-RING	1				
15	93210-32172	.O-RING	1				
16	95027-06020	.BOLT, FLANGE	2				
17	98507-06016	.SCREW, PAN HEAD	1				
18	5UH-F834L-00	.BRKT., METER	1				
19	5UH-F837L-11	.PANEL, CONSOLE 1	1				
20	98517-05010	.SCREW, PAN HEAD	3				
21	5UH-H252R-00	.DAMPER	1				
22	1M1-83526-00	.DAMPER 2	2				
23	4X8-83524-00	.WASHER, SPECIAL	2				
24	437-83525-00	.CLIP	2				
25	5VH-H3550-00	.SPEEDOMETER CABLE ASSY	1				
26	93210-14104	.O-RING	1				
27	98580-06030	.SCREW, PAN HEAD	1				

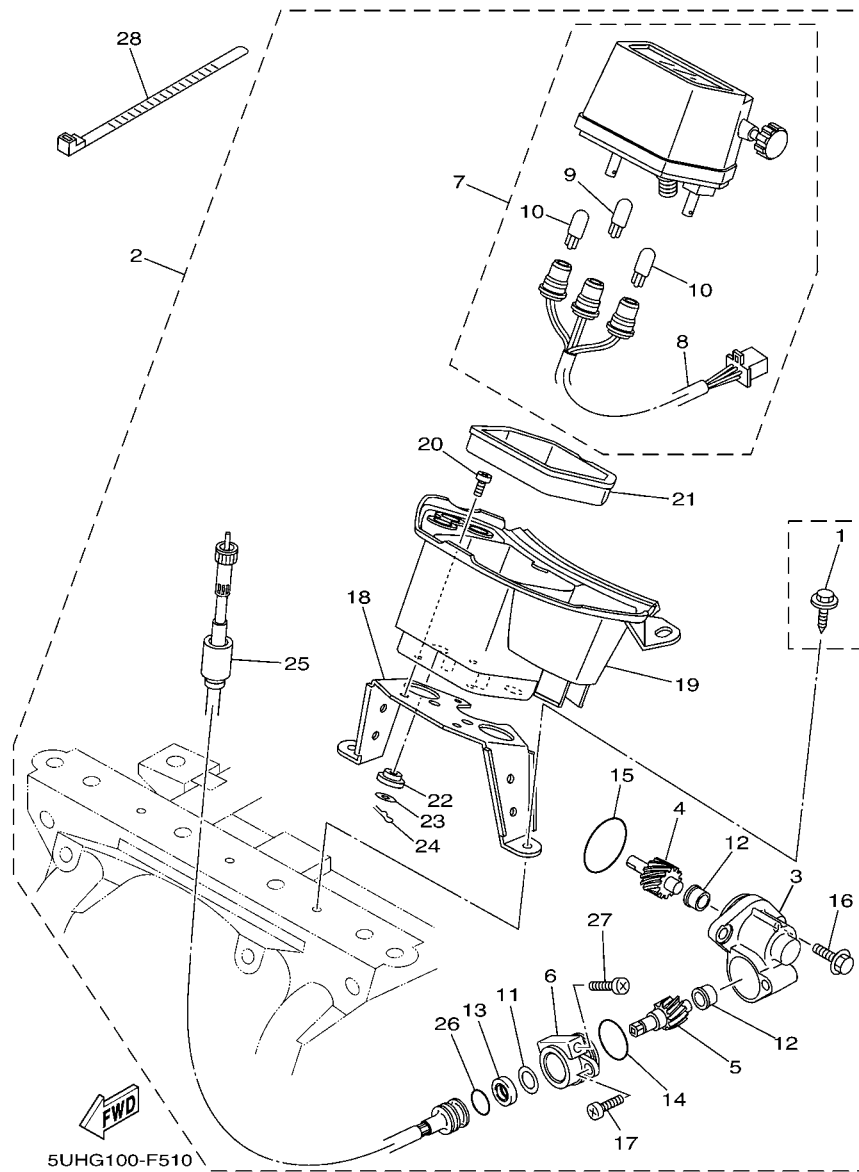

FIG. 46 ALTERNATE FOR METER

REF. NO.	PART NO.	DESCRIPTION	USA				REMARKS
28	90464-31827	CLAMP	1				AP 122X4.80

NUMERICAL INDEX

PART NO.	REF. NO.	PART NO.	REF. NO.	PART NO.	REF. NO.	PART NO.	REF. NO.	PART NO.	REF. NO.	PART NO.	REF. NO.
5YT-11101-20	1 - 1	3GD-12213-00	5 - 16	5GH-14937-00	8 - 35	5UH-17168-00	14 - 4	4WV-17841-00	46 - 5	2HR-2512J-00	29 - 12
3Y1-1111F-00	1 - 8	31G-12214-00	5 - 15	5GH-14940-10	8 - 4	5UH-17223-10	14 - 8	5UH-18103-00	16 - 1		29 - 39
3Y1-11127-00	1 - 7	31G-12222-00	5 - 14	256-14956-01	8 - 44	5UH-17285-00	14 - 14	1NS-18115-00	16 - 18	4SH-25367-01	31 - 11
4X7-11127-00	2 - 1	5UH-12231-00	5 - 11	3H1-14962-00	8 - 8	5UH-17421-10	14 - 6	3B4-18125-00	16 - 24	3GD-2580T-01	30 - 5
3Y1-11133-11	1 - 2	5UH-12241-00	5 - 12	5DM-14985-00	8 - 30	5UH-17453-00	14 - 10	28P-18174-00	16 - 30	3GD-2580U-01	30 - 20
4KB-11145-00	5 - 9	1NS-13132-00	6 - 13	7T9-14987-00	8 - 42	5UH-17521-00	15 - 1	1NS-18191-00	16 - 15	3GD-25827-00	30 - 10
4WU-11160-01	1 - 18	5UH-1319K-00	6 - 10	5UH-15100-09	10 - 1	5UH-17523-00	14 - 20	3B4-18196-00	16 - 25	3GD-25828-00	30 - 25
4KB-11165-00	1 - 19	5UH-13300-00	6 - 1	5UH-15113-00	11 - 4	4VR-17527-00	15 - 21	4SH-18198-00	16 - 11	5MV-25833-00	33 - 7
1UY-11181-01	1 - 11	5UH-13327-00	6 - 4	5UH-15163-00	13 - 4	5UH-17530-10	15 - 8	5GH-18318-00	23 - 11	5KM-2583T-10	33 - 1
2NL-11186-12	1 - 25	5UH-13329-00	6 - 2	5UH-15315-00	11 - 19	5GH-17531-00	15 - 18	5GH-18319-00	23 - 15	5LP-25852-02	33 - 4
2NL-11187-11	1 - 26	5UH-13411-00	6 - 6	5KM-15351-00	11 - 23	5KM-17531-00	15 - 5	5UH-18511-00	16 - 5	4L0-25854-00	33 - 3
214-11198-01	10 - 13	5GH-13440-20	6 - 11	517-15362-10	11 - 13	5GH-17531-10	15 - 18	5GH-18514-01	23 - 13	2GU-25866-00	33 - 13
	22 - 14	5UH-13586-00	7 - 1	2N4-15371-00	22 - 15	5KM-17531-10	15 - 5	2A6-18535-00	16 - 6	5GM-25867-10	33 - 6
	23 - 32	5UH-14103-00	8 - 39	5UH-15379-00	11 - 24	5GH-17531-20	15 - 18	2HR-23526-00	25 - 11	5FU-2589F-00	41 - 4
5YT-11310-00	2 - 2	5UH-14105-10	8 - 7	4WV-15381-00	10 - 17	5KM-17531-20	15 - 5	37S-23549-01	25 - 2	1FK-2589F-10	33 - 11
4KB-11351-00	2 - 8	4SV-14107-20	8 - 14	2K7-15383-00	10 - 10	5GH-17531-30	15 - 18		25 - 5	3GD-25914-00	30 - 18
5UH-11400-00	3 - 1	5UH-1410A-00	8 - 21	11H-15383-02	15 - 3	5KM-17531-30	15 - 5		29 - 22		30 - 33
5UH-11401-09	3 - 2	5DM-14112-00	8 - 5	5GH-15385-00	10 - 21	5GH-17531-40	15 - 18		29 - 49	3GD-25916-00	30 - 19
5UH-11402-09	3 - 3	5DM-14141-42	8 - 16	5GH-15388-00	10 - 8	5KM-17531-40	15 - 5	8K1-23814-00	26 - 3		30 - 34
5KM-11447-00	3 - 18	4KM-14142-17	8 - 36	5UH-15411-00	11 - 1	5GH-17531-50	15 - 18	1NS-23831-00	26 - 15	1UY-25917-51	30 - 13
5UH-11454-01	3 - 24	3H1-14147-00	8 - 9	5UH-15420-00	11 - 17	5KM-17531-50	15 - 5	1UY-23841-01	26 - 16		30 - 28
5UH-11531-00	3 - 27	522-14161-00	8 - 27	5UH-15421-00	11 - 18	5GH-17531-60	15 - 18	1UY-23845-01	26 - 17	1UY-25919-51	30 - 15
5UH-11536-00	3 - 8	5FU-14167-00	8 - 43	5UH-15431-00	11 - 21	5KM-17531-60	15 - 5	2GU-23872-00	17 - 10		30 - 30
5UH-11565-00	3 - 11	127-14186-00	8 - 13	5UH-15442-00	10 - 14	5KM-17531-70	15 - 5	1UY-23894-01	26 - 10	1UY-25926-51	30 - 17
4GB-11610-00	3 - 20	3FV-14191-00	8 - 23	5UH-15451-00	11 - 6	5GH-17551-00	15 - 9	5UH-24311-00	27 - 18		30 - 32
4GB-11610-20	3 - 20	24W-14193-00	7 - 7	5UH-15463-00	13 - 13	5UH-17556-10	15 - 14	5KM-24500-10	27 - 3	3GD-25933-00	30 - 11
4GB-11610-40	3 - 20	4KB-14193-20	8 - 19	3C2-15492-00	11 - 15	5UH-17582-11	14 - 7	4X8-24512-10	27 - 7		30 - 26
5UH-11631-00-C0	3 - 19	5FU-14197-00	8 - 31	5UH-15512-00	12 - 1	5UH-17583-01	14 - 22	3AC-24523-00	27 - 4	1UY-25934-51	30 - 14
55V-11633-00	3 - 22	3DM-14216-00	8 - 45	5UH-15517-00	12 - 3	5UH-17585-00	15 - 22	3AJ-24534-10	27 - 5		30 - 29
5UH-11636-00	3 - 19	4KM-14216-00	8 - 17	1VJ-15521-00	12 - 2	5UH-17611-00	13 - 27	5KM-24610-00	27 - 2	1UY-25937-51	30 - 12
5UH-11638-00	3 - 19	1HX-14231-16	8 - 18	5KM-15590-00	12 - 5	5UH-1761A-00	15 - 25	4S1-2510F-00	29 - 6		30 - 27
5UH-11651-00	3 - 6	3G2-1423A-62	8 - 22	5UH-15710-00	45 - 1	5UH-17620-00	13 - 15		29 - 33	1UY-25938-51	30 - 16
30X-11681-00	3 - 4	3G2-1423E-51	8 - 10	5UH-15713-00	45 - 3	5UH-17623-00	13 - 18	4S1-2510G-00	29 - 7		30 - 31
1UY-12111-01	4 - 1	5DM-14261-00	8 - 11	24W-15714-00	45 - 11	4WV-17632-00	13 - 17		29 - 34	1NV-26129-00	32 - 14
22U-12113-00	4 - 4	5UH-14348-00	8 - 41	21V-15715-01	45 - 4	5UH-17639-00	13 - 22	4S1-2510H-00	29 - 8	3B4-26232-01	43 - 1
1UY-12114-01	4 - 5	31A-14419-00	7 - 24	5UH-15716-00	45 - 10	5UH-17641-01	13 - 26		29 - 35	4WV-26250-11	32 - 5
3Y1-12116-00	4 - 3	5BF-1443E-00	11 - 27	5KM-15723-00	45 - 13	5UH-17644-00	13 - 37	4S1-2510J-00	29 - 9	1NV-26259-01	32 - 11
3Y1-12117-01	4 - 7		19 - 6	3D5-15730-00	11 - 38	5UH-17645-00	13 - 25		29 - 36	1NV-2625G-01	32 - 15
1J7-12118-00	4 - 8	583-14561-00	8 - 12	21V-15741-00	45 - 2	4WV-17653-00	13 - 19	4S1-2511E-01	29 - 14	1NV-2625K-00	32 - 12
1UY-12121-01	4 - 2	5DM-14561-00	8 - 15	21V-15751-00	45 - 6	4WV-17654-01	13 - 20		29 - 41	4KB-2628F-10	32 - 6
M01-12129-00	4 - 6	1FN-14565-00	8 - 29	3X3-15755-00	45 - 8	5UH-17660-00	13 - 30	4S1-2511G-00	29 - 15	4KB-2628G-00	32 - 7
3GD-12151-11	4 - 9	3GD-14613-00	9 - 8	21V-15767-00	45 - 5	4CW-17664-00	13 - 34		29 - 42	1NV-26304-00	32 - 10
4SH-12156-00	4 - 11	3B4-14759-01	9 - 23	21V-15779-00	45 - 9	5UH-17670-00	13 - 31	3HN-2511G-01	29 - 10	5GH-26311-10	32 - 24
31G-12158-00	4 - 14	5EL-1490H-00	8 - 37	5UH-16181-00	3 - 17	5UH-17681-20	14 - 1		29 - 37	1NS-26341-00	32 - 26
31G-12159-02	4 - 13	5UH-1490J-10	8 - 2	5UH-16611-00	13 - 1	5UH-17684-00	13 - 36	3HN-2512G-01	29 - 11	20E-26343-00	32 - 27
5UH-12170-10	5 - 1	5GH-14918-10	8 - 6	5UH-16620-00	13 - 2	4WV-17811-00	46 - 3		29 - 38		34 - 8
5UH-12176-00	5 - 6	5DM-14933-00	8 - 3	5UH-16626-00	13 - 3	59V-17811-00	46 - 6	4KB-2512H-00	29 - 13	1NS-26361-00	34 - 22
31G-12210-01	5 - 13	4XE-14937-00	8 - 40	5GH-16664-00	13 - 11	4WV-17831-00	46 - 4		29 - 40	5GH-2637F-10	34 - 23

NUMERICAL INDEX

PART NO.	REF. NO.	PART NO.	REF. NO.	PART NO.	REF. NO.	PART NO.	REF. NO.	PART NO.	REF. NO.	PART NO.	REF. NO.
1NV-26398-00	32 - 9	5GT-81960-00	42 - 14	2GU-84334-00	39 - 6	5UH-E5336-00	17 - 2	5FU-F175B-01	18 - 3	5FU-F5336-00	31 - 40
109-27114-00	21 - 9	3WP-81980-00	42 - 43	5EH-84340-00	39 - 3		17 - 4	1NS-F1788-00	43 - 2	5VH-F533A-01	31 - 20
5KM-27414-01	9 - 24	371-82121-00	42 - 18	5KM-84710-00	40 - 1	5UH-E5471-00	11 - 26	1NS-F2110-00	21 - 1	5VH-F5351-01	31 - 17
1NV-2811A-01	17 - 15	1AE-82151-00	42 - 30	1A2-84714-41	40 - 2	5ND-E5472-00	11 - 29	5ND-F2123-00	21 - 2	5VH-F5355-01	31 - 23
3HN-46108-01	22 - 32	5JJ-82151-10	42 - 40	5KM-8472C-10	40 - 3	5ND-E5473-00	11 - 31	5ND-F2189-00	21 - 5	5VH-F5359-00	31 - 26
4WV-46119-01	23 - 5	5JJ-82151-30	42 - 41	5UH-85540-00	42 - 1	5UH-E5474-00	11 - 32	4XE-F219X-01	21 - 8	5FU-F537Y-00	31 - 33
4WV-46119-11	23 - 5	5JJ-82151-50	42 - 42	3C2-E1166-00	1 - 21	1NS-E5491-00	11 - 30	1NS-F2210-00	24 - 1	1NS-F5381-00	31 - 36
4WV-46119-21	23 - 5	3D5-82180-00	42 - 38	1NS-E2405-00	6 - 15	4XE-E7537-15	22 - 25	4S2-F2327-01	29 - 58	1NS-F5384-00	31 - 43
4WV-46119-31	23 - 5	5KM-82310-00	42 - 7	1NS-E3464-00	6 - 19	4XE-E7537-30	22 - 25	4S2-F2328-01	29 - 59	1NS-F5390-00	31 - 1
4WV-46119-41	23 - 5	3NS-82370-00	42 - 11	1NS-E3465-00	6 - 20	4XE-E7537-40	22 - 25	5ND-F3192-01	33 - 18		31 - 4
4WV-46119-51	23 - 5	5KM-82510-00	42 - 33	1NS-E3480-00	6 - 16	4XE-E7537-45	22 - 25	1NS-F3500-00	25 - 14	5VH-F539F-01	31 - 27
5GH-46123-00	23 - 36	5LP-82510-00	42 - 33	1NS-E3573-00	6 - 18	4XE-E7537-50	22 - 25	1NS-F3501-00	29 - 17	1P0-F5411-00	31 - 8
29U-46125-00	22 - 10	4KB-82530-10	42 - 36	1NS-E3577-00	6 - 17	4XE-E7537-60	22 - 25	1NS-F3502-00	29 - 44		31 - 42
5GH-46126-01	23 - 27	3GB-82540-01	42 - 5	5UH-E4101-11	8 - 1	1NS-E8154-00	16 - 33	5ND-F3540-13	25 - 1	5VH-F5818-00	31 - 25
4WV-46132-00	23 - 19	3GD-82540-11	23 - 18	5FU-E4147-00	8 - 25	1NS-E8155-00	16 - 28	5ND-F3550-13	25 - 4	5ND-F582T-00	30 - 1
5GH-46136-00	23 - 38	3D5-82560-00	42 - 39	5FU-E4155-00	8 - 38	1NS-E8169-00	16 - 22	5ND-F357A-01	25 - 9		30 - 3
5KM-46137-00	23 - 39	3HN-82569-00	42 - 34	5UH-E4191-00	7 - 17	1NS-E8172-00	16 - 32	5ND-F358A-01	25 - 10	5ND-F5871-00	33 - 15
5GH-46141-01	23 - 4	3HN-82579-00	42 - 35	5UH-E4349-00	7 - 6	1NS-E8190-00	16 - 21	37S-F3812-00	26 - 6	5ND-F5872-01	33 - 12
4WV-46143-00	23 - 10	1NS-82590-00	42 - 37	5UH-E4411-00	7 - 9	1NS-E8380-00	16 - 26	5ND-F3813-10	26 - 1	1NS-F5873-00	33 - 14
4WV-46155-00	23 - 7	1NS-82590-10	42 - 37	5UH-E4412-00	7 - 13	1NS-F1110-00	17 - 1	1NS-F3816-00	26 - 2	5ND-F5875-01	33 - 16
4WV-46159-00	23 - 9	1YW-82911-10	41 - 1	5UH-E4424-00	7 - 15	1NS-F1338-00	42 - 58	1HP-F3868-00	26 - 8	5VH-F5898-00	31 - 24
5GH-46160-05	23 - 1	4V4-82913-00	32 - 21	5ND-E442F-00	7 - 19	5B4-F1338-00	42 - 51	5UH-F4110-10	27 - 1	5UH-F5921-00	38 - 1
5GH-46161-01	23 - 2	5LP-82913-11	41 - 2	5ND-E4437-02	7 - 21		42 - 52	5UH-F414H-01	27 - 21	5FU-F6111-10	32 - 1
5GH-46162-01	23 - 3	5GH-83516-00	42 - 25	5UH-E4438-00	7 - 18		42 - 53	1NS-F4524-00	27 - 8	5ND-F6124-01	32 - 3
3B4-46163-00	23 - 23		42 - 27	1NS-E4451-00	7 - 12		42 - 54	5ND-F470F-01	28 - 2	5FU-F6241-10	32 - 2
5TE-46163-00	23 - 29	2GV-83517-00	46 - 10	5UH-E4453-00	7 - 20		42 - 55	5ND-F4710-04	28 - 1	5VH-F6331-00	32 - 25
4WV-46165-00	23 - 16	42X-83517-00	46 - 9	5UH-E4458-00	7 - 10		42 - 57	4XE-F4747-00	28 - 3	5TE-F7211-00	34 - 3
4WV-46167-00	23 - 17	4X8-83524-00	46 - 23	5UH-E4462-00	7 - 14	4XE-F1399-00	35 - 2	5ND-F4776-00	28 - 5	5UH-F741A-10	34 - 17
5GH-4616A-02	23 - 12	437-83525-00	46 - 24	5UH-E4468-00	7 - 11	5ND-F147A-02	17 - 17	4XE-F478V-00	28 - 4	5ND-F7445-00	34 - 16
2HR-46187-00	22 - 35	1M1-83526-00	46 - 22	5UH-E4611-00	9 - 1	5UH-F1500-H1	18 - 1	1NS-F4841-00	35 - 4	5UH-F7445-01	34 - 25
4WV-46441-00	23 - 14	5TE-83530-00	42 - 24	5UH-E4612-00	9 - 2	5UH-F1500-J1	18 - 1	1NS-F4842-00	35 - 6	5ND-F7453-01	34 - 14
5GH-46470-04	23 - 6	5UH-83530-00	42 - 26	5UH-E4628-01	9 - 4	5TE-F151E-00	44 - 5	5ND-F4877-30	44 - 6	5ND-F7463-01	34 - 15
5UH-81410-00	36 - 1	4SH-83536-10	46 - 8	5UH-E4638-00	9 - 17	5ND-F151K-00	44 - 11	5ND-F4897-30	44 - 10	5ND-F7471-01	34 - 1
5UH-81450-00	36 - 5	12S-83570-00	46 - 7	1NS-E4711-00	9 - 9	4XE-F1539-10	44 - 3	5ND-F5111-21	29 - 24	1CT-F8100-00	17 - 14
3AJ-81809-00	37 - 4	4GB-83591-10	42 - 12	5ND-E4714-00	9 - 18		44 - 8		29 - 51	1P0-F816L-00	44 - 2
3XF-81815-00	37 - 9	1UY-83909-00	41 - 13	5ND-E4715-00	9 - 19	5UG-F153A-70	43 - 3	2P5-F512A-00	29 - 5	5FU-F816M-00	44 - 7
3HE-81826-00	37 - 6	2HT-83912-00	41 - 3	5ND-E4718-00	9 - 12	4XE-F1549-00	44 - 4		29 - 32	1P0-F8186-01	44 - 13
4XV-8182A-00	37 - 11	5KM-83922-00	33 - 8	5ND-E4719-00	9 - 11		44 - 9	5ND-F514A-00	29 - 55	4XE-F819R-20	44 - 12
3HE-81830-00	37 - 5	5GH-83941-00	41 - 12	1NS-E4728-00	9 - 14	4XE-F1568-00	44 - 1	1D9-F5180-10	29 - 1	5UH-F8309-01	18 - 2
3HE-81840-00	37 - 2	3L4-83943-00	41 - 14	1NS-E4737-00	9 - 25	5ND-F1600-W1	19 - 1		29 - 28	5UH-F8349-00	18 - 9
11H-81844-00	37 - 7	1YW-83965-00	41 - 8	5ND-E4752-00	9 - 10	5ND-F1600-X1	19 - 1	1NS-F5183-00	31 - 7	5UH-F834L-00	46 - 18
1FK-81847-00	37 - 8	5LP-83973-01	41 - 11	5ND-E4759-00	9 - 21	5ND-F163A-02	19 - 8	1NS-F5186-00	31 - 41	5UH-F837L-00	38 - 3
3HE-81850-00	37 - 3	4WV-83976-00	32 - 20	5UH-E4769-10	7 - 16	5ND-F163E-00	19 - 9	1NS-F530B-00	31 - 45	5UH-F837L-11	46 - 19
4G0-81871-00	37 - 10	5LP-83980-00	33 - 10	5ND-E4777-00	9 - 20	1NS-F163F-00	19 - 11	5FU-F5319-10	31 - 31	5UH-F845N-00	35 - 1
3HE-81890-00	37 - 1	3FA-83980-03	41 - 7	1NS-E477R-00	9 - 3	5ND-F1652-00	19 - 10	5FU-F531E-10	31 - 39	5ND-F8488-20	21 - 11
4SV-81940-12	42 - 29	4KB-84314-01	39 - 1	5UH-E477T-00	9 - 5	5UH-F171A-10	20 - 1	5VH-F5321-01	31 - 16	1NS-G6101-00	22 - 1
5DM-81950-00	42 - 45	5KM-84320-01	39 - 2		9 - 15	5UH-F171A-50	20 - 1	5FU-F5327-01	31 - 30	4XE-G6102-00	22 - 4
29U-81950-93	42 - 44	2GU-84332-00	39 - 5	5ND-E4788-00	9 - 13	5ND-F174M-00	20 - 2	5VH-F5333-00	31 - 19	4XE-G6117-25	22 - 27

NUMERICAL INDEX

PART NO.	REF. NO.	PART NO.	REF. NO.	PART NO.	REF. NO.	PART NO.	REF. NO.	PART NO.	REF. NO.	PART NO.	REF. NO.
4XE-G6117-30	22 - 27	3GD-W0057-00	30 - 21	90151-04006	27 - 9	90201-10036	22 - 39	90387-06113	6 - 23	90467-140A4	1 - 22
4XE-G6117-35	22 - 27	1NS-W0081-00	46 - 2	90151-06023	10 - 11	90201-10038	3 - 14	90387-0613B	16 - 12	90467-150A0	6 - 21
4XE-G6117-40	22 - 27	5VH-WF536-00	31 - 18	90154-05021	39 - 8	90201-10118	33 - 21	90387-066J1	27 - 13	90467-160A4	11 - 28
4XE-G6117-45	22 - 27	5GT-Y4612-00	22 - 7	90157-04006	13 - 23	90201-10128	1 - 16	90387-07021	27 - 16		19 - 7
4XE-G6117-50	22 - 27	90101-06824	31 - 21	90160-05007	29 - 57	90201-10591	5 - 8	90387-090R0	26 - 11	90480-01400	27 - 15
4XE-G6118-10	22 - 26	90101-10016	5 - 7	90170-06228	16 - 19	90201-12172	10 - 7	90387-16547	2 - 4	90480-13018	11 - 22
4XE-G6118-11	22 - 26	90101-10017	3 - 15	90170-10010	26 - 19		42 - 13	90387-252R2	15 - 27	90480-15235	6 - 22
4XE-G6118-12	22 - 26	90105-05016	6 - 7	90170-16326	3 - 30	90201-12M34	46 - 11	90387-255H9	22 - 9	90480-18290	27 - 12
4XE-G6118-13	22 - 26	90105-06081	10 - 22	90170-36279	13 - 38	90201-132G5	16 - 13	90387-284T0	31 - 37	90501-101A7	6 - 9
4XE-G6118-14	22 - 26	90105-06831	42 - 20	90171-10001	26 - 21	90201-14021	26 - 12	90401-10015	33 - 20	90501-10353	16 - 8
4XE-G6118-15	22 - 26	90105-06833	19 - 4	90171-12001	25 - 7	90201-14023	34 - 7	90401-20008	6 - 12	90501-10782	32 - 28
4XE-G6118-16	22 - 26		42 - 15	90179-06668	9 - 7	90201-15701	16 - 3	90430-06192	1 - 5		34 - 9
4XE-G6118-17	22 - 26	90105-08150	15 - 7	90179-08030	41 - 10	90201-166R6	15 - 15	90430-10003	23 - 25	90501-22721	3 - 9
4XE-G6118-18	22 - 26	90105-08161	30 - 35	90179-10022	29 - 4	90201-17013	14 - 13	90430-10148	42 - 6	90501-290A1	23 - 37
4XE-G6118-19	22 - 26	90105-088A4	31 - 35		29 - 31	90201-190T7	13 - 28	90430-14043	6 - 14	90501-580A0	13 - 35
4XE-G6118-20	22 - 26	90105-10051	17 - 11		31 - 9	90201-20278	14 - 11	90430-14194	16 - 10	90501-650L5	15 - 20
4XE-G6118-21	22 - 26	90105-10136	1 - 15		31 - 15	90201-21015	14 - 9	90430-14240	1 - 13	90506-07135	21 - 6
1NS-G6151-00	22 - 2	90105-10137	1 - 14	90179-16005	13 - 29	90201-25290	12 - 4	90445-07807	31 - 48	90506-12403	34 - 24
1NS-G6152-00	22 - 16	90105-10284	17 - 5		13 - 39	90202-05193	27 - 10	90445-07809	23 - 33	90506-16482	31 - 29
5FU-G6156-00	22 - 23	90105-10287	31 - 46	90179-16006	15 - 16	90206-12001	4 - 10	90445-07810	22 - 40	90508-35764	16 - 14
5FU-G6157-10	22 - 28	90105-10841	25 - 16	90179-20016	29 - 27	90209-06012	6 - 24	90445-088C5	27 - 20	90560-30325	29 - 21
5FU-G6157-15	22 - 28	90105-14003	16 - 9		29 - 54	90209-10229	26 - 20	90450-47002	7 - 5		29 - 48
5FU-G6157-20	22 - 28	90109-06172	16 - 34		31 - 44	90209-33253	3 - 7	90450-56008	7 - 25	91312-05012	11 - 5
5FU-G6157-30	22 - 28		17 - 18	90179-22005	13 - 12	90215-06162	1 - 10	90450-58002	7 - 22		36 - 4
5FU-G6157-40	22 - 28	90109-06262	34 - 19	90179-22015	15 - 6	90215-16258	3 - 29		7 - 23	91312-06020	1 - 28
5FU-G6157-50	22 - 28	90109-06865	42 - 8	90179-55660	15 - 28	90240-08005	34 - 11	90450-64002	11 - 33	91312-06025	1 - 24
5ND-G6172-10	22 - 30	90109-08082	30 - 2	90179-65305	15 - 11	90249-12008	32 - 29	90460-85277	21 - 7		11 - 16
5TE-G6173-10	23 - 35		30 - 4	90183-05008	39 - 7		34 - 10	90461-08134	11 - 36	91312-06030	2 - 7
4XE-G6513-00	31 - 34	90110-06007	20 - 5	90183-051A0	20 - 4	90267-489U1	34 - 26	90462-06016	42 - 3	91312-08016	12 - 6
5UH-H1318-00	42 - 9	90110-06285	45 - 12	90183-06053	18 - 8	90267-489U9	34 - 18	90464-10833	42 - 32	91312-08025	7 - 3
5FU-H191B-10	42 - 66	90113-08004	23 - 21	90183-080A1	16 - 23	90269-05055	16 - 31	90464-12830	42 - 47	91312-08050	1 - 17
5FU-H1920-10	42 - 65	90114-10014	29 - 25		16 - 29	90269-06800	11 - 34		42 - 59	91317-08020	23 - 8
5TE-H2100-00	42 - 16		29 - 52	90183-08800	18 - 4	90269-06804	18 - 7		42 - 61	91402-20020	34 - 13
5TE-H2115-00	42 - 22	90116-06041	1 - 6		38 - 4	90269-08813	11 - 35	90464-25826	42 - 63	91402-20025	26 - 14
5UH-H2116-00	42 - 23	90116-10593	22 - 3	90185-10012	25 - 13	90280-05048	3 - 13	90464-31827	42 - 49	91402-25020	25 - 8
5ND-H2119-00	42 - 19	90119-06157	18 - 5		25 - 15	90282-05013	3 - 28		42 - 60		26 - 22
5TE-H2128-01	42 - 17		18 - 6	90185-12009	21 - 4	90336-28053	26 - 5		46 - 28		31 - 28
5UH-H252R-00	46 - 21		19 - 3		24 - 3	90338-08226	42 - 4	90464-40825	42 - 46	91A20-07014	7 - 8
5FU-H2599-01	42 - 67		35 - 8	90185-14009	26 - 13	90338-09801	19 - 2		42 - 48	92502-06030	36 - 2
5VH-H3550-00	46 - 25		38 - 2	90201-047R9	13 - 24	90338-14827	32 - 4		42 - 50	92902-04100	8 - 33
8CR-W0041-00	33 - 2		46 - 1	90201-06036	16 - 16		42 - 28		42 - 56	92902-05600	32 - 23
3GD-W0045-01	30 - 9	90119-08114	15 - 19		19 - 5	90340-10001	23 - 24	90464-48800	42 - 62	92902-06600	5 - 19
	30 - 24	90123-08002	41 - 9	90201-06095	10 - 23	90340-14029	10 - 12		42 - 64		36 - 3
3GD-W0047-00	30 - 7	90149-04278	32 - 16	90201-06097	40 - 4		22 - 24	90465-08127	11 - 10	92902-08600	22 - 21
	30 - 22	90149-05034	20 - 3	90201-08066	34 - 12		23 - 31	90467-07029	22 - 41	92907-04600	8 - 34
1UY-W0048-50	30 - 8		34 - 20	90201-08070	7 - 4	90340-14046	22 - 13		23 - 34	92907-05100	41 - 16
	30 - 23	90149-06108	27 - 11	90201-10035	17 - 13	90340-14117	11 - 11	90467-070A0	31 - 49	93101-12168	10 - 16
3GD-W0057-00	30 - 6	90149-08013	15 - 4		31 - 47	90381-08002	46 - 12	90467-100A1	27 - 19	93101-31167	13 - 16

NUMERICAL INDEX

PART NO.	REF. NO.	PART NO.	REF. NO.	PART NO.	REF. NO.	PART NO.	REF. NO.	PART NO.	REF. NO.	PART NO.	REF. NO.
93101-35097	15 - 13	93211-51749	22 - 19	93450-44141	23 - 26	95702-06500	45 - 7	98507-05030	41 - 17		
	31 - 14	93211-52001	13 - 21	93450-71142	23 - 28	95702-10500	22 - 38	98507-06016	46 - 17		
93101-38098	22 - 12	93306-00401	14 - 2	93503-08007	16 - 7	95802-06030	27 - 14	98517-05010	46 - 20		
93101-52116	22 - 5	93306-00438	5 - 4	93505-16006	6 - 8		27 - 17	98517-05012	41 - 15		
93102-08307	46 - 13	93306-00502	5 - 5	93603-14240	14 - 23	9580P-06040	9 - 16	98580-04010	8 - 20		
93102-15212	16 - 2	93306-00612	3 - 25	93604-10011	5 - 3	95812-06012	29 - 56	98580-06030	46 - 27		
93102-25081	17 - 8		15 - 23	93605-10090	3 - 10		31 - 32	98702-04012	33 - 5		
93102-25099	17 - 9	93306-006Y2	29 - 18	93900-00813	29 - 3		33 - 17	99009-32400	3 - 12		
93102-28017	11 - 3		29 - 45		29 - 30		33 - 19		25 - 3		
93102-30170	15 - 24	93306-008Y0	31 - 10		31 - 3	95812-06016	9 - 6		25 - 6		
93102-32483	13 - 6	93306-07801	11 - 2		31 - 6	95812-06020	6 - 25		29 - 23		
93102-35380	15 - 29	93306-20103	10 - 15	94108-12816	29 - 2		42 - 10		29 - 50		
93102-42004	14 - 5	93306-20306	14 - 18		29 - 29	95812-06025	33 - 22	99009-80500	13 - 7		
93102-65386	22 - 17	93306-203YN	17 - 7	94110-12813	31 - 2	95812-06035	16 - 17	99530-10116	10 - 2		
93104-09025	32 - 13	93306-20402	3 - 26		31 - 5	95812-08012	16 - 27		10 - 20		
93104-41119	13 - 32	93306-20464	14 - 17	94591-54034	14 - 19		21 - 10		11 - 7		
93106-38046	29 - 19	93306-20532	15 - 2	94591-87110	5 - 10		34 - 2	99530-14016	1 - 12		
	29 - 46	93306-20582	15 - 26	94701-00333	1 - 29		35 - 3		2 - 6		
93106-38047	29 - 20	93306-20601	14 - 3	95022-06008	42 - 31		35 - 5				
	29 - 47	93306-20715	15 - 12	95022-06012	1 - 20		35 - 7				
93106-47040	31 - 12	93306-278Y0	31 - 13		6 - 5	95812-08030	26 - 4				
93112-31800	26 - 7	93306-30538	15 - 10		10 - 18	95812-08040	9 - 22				
93210-09165	4 - 12	93306-305Y6	22 - 8		11 - 37	95812-10020	21 - 12				
93210-14104	46 - 26	93306-30611	3 - 16	95022-06014	1 - 4	95812-10025	22 - 22				
93210-14299	14 - 16	93310-420F2	14 - 12	95022-06020	41 - 6	95812-10070	25 - 12				
93210-14369	11 - 12	93310-633P5	3 - 5	95022-06025	5 - 17	95812-10080	17 - 3				
93210-16290	11 - 39	93311-42077	14 - 25		6 - 3	95812-12080	21 - 3				
	45 - 14	93315-21813	13 - 9		37 - 12		24 - 2				
93210-17003	5 - 2	93316-00801	23 - 30	95022-06030	11 - 9	95822-06012	10 - 9				
	14 - 15	93316-01003	13 - 5		13 - 14	95822-06020	11 - 25				
93210-18322	2 - 5	93316-013Y0	22 - 18	95022-06050	10 - 3	95822-06030	10 - 19				
93210-19026	11 - 14	93317-855Y9	22 - 6		11 - 8		11 - 20				
93210-24253	46 - 14	93399-99926	22 - 33	95022-06070	10 - 5	97002-06012	1 - 9				
93210-26606	31 - 38		22 - 36	95022-08045	10 - 4	97012-06020	34 - 5				
93210-27666	29 - 26	93410-22039	22 - 31	95022-12040	10 - 6	97022-06016	5 - 18				
	29 - 53	93410-46079	13 - 8	95027-06020	46 - 16	97022-08025	22 - 20				
93210-32172	46 - 15	93430-10015	34 - 6	95302-10700	26 - 18	97022-08060	26 - 9				
93210-44545	7 - 2	93440-12052	1 - 3	95304-06700	16 - 20	97602-04110	32 - 19				
	13 - 33	93440-14155	14 - 24	95307-05700	32 - 17	97702-60016	42 - 21				
93210-50768	23 - 20	93440-15012	16 - 4	95312-06700	34 - 4	97702-60420	42 - 2				
93210-57634	1 - 27	93440-20088	22 - 34	95602-05100	32 - 8	98501-04014	8 - 32				
93210-59531	22 - 11		22 - 37	95602-05200	34 - 21	98502-03540	39 - 4				
93210-64297	17 - 16	93440-25084	14 - 21	95602-06100	41 - 5	98502-05020	32 - 22				
93210-76800	22 - 29	93450-19095	3 - 21	95602-10200	17 - 6	98507-03014	27 - 6				
93210-78544	15 - 17		3 - 23		17 - 12	98507-04006	8 - 24				
93210-86509	2 - 3	93450-22119	29 - 16	9560L-06200	31 - 22	98507-04008	8 - 28				
93211-06635	1 - 23		29 - 43	95701-06500	33 - 9	98507-04014	8 - 26				
93211-40040	23 - 22	93450-24062	13 - 10	95702-06300	40 - 5	98507-05020	32 - 18				